

SHIPPING CONTAINER HOMES MADE EASY

Step By Step Guide On How To Build Your First Shipping Container Home From Scratch As A Complete Beginner



TONYA JOHNSON

Shipping Container Homes Made

Easy

Step By Step Guide On How To Build

Your First Shipping Container Home

From Scratch As A Complete

Beginner

Introduction

Do you want to build a shipping container home but don't know where to start? Are you confused about the estimated costs, timelines, and how to get your container home approved? If you have, you've found a book written by an expert.

Although shipping containers homes are your cheaper way out of mortgage and rental bills, you need to know how to do it right and avoid costly mistakes that people make in their first attempt to build one.

This book outlines easily applicable ways to turn your ideas into reality and build the perfect container home. By the end of this read, you will have answers to many of the questions you may have about container homes.

Plus, you will have a detailed walk-through of each step involved in building a shipping container home, from container selection, transportation, foundation, modification, up to finishing. Each chapter has pictures of each stage of construction with real-life examples to boost your insight.

You will also discover:

- Why you should choose shipping container homes and their advantages.
- How to pick a good location for your shipping container home.
- Unique techniques, plans, tips, designs.
- How to promptly and effectively plan your project, determine the budget, check zoning laws, buildings codes, and permits.
- The best way to prepare your site, including the foundation, thus ensuring that you get everything perfectly ready to start building your

container home.

- The art of selecting the best shipping container, including the available types, quality, age, grade, prices, condition.
- Shipping, delivery, and place placement of containers.
- How to fit the roof.
- How to fix essential services: electricity, water, sewage, telephone line
- How to modify your container.
- ***And much, much more!***

Whether you want a getaway place to relax or are looking to live off the grid in a virtually maintenance-free home, container homes are a great choice, and you have picked the right book. This guide will help you build your first container home in no time at all.

Let's jump right in!

PS: I'd like your feedback. If you are happy with this book, please leave a review on Amazon.

Please leave a review for this book on Amazon by visiting the page below:

<https://amzn.to/2VMR5qr>

Table of Contents

[Introduction](#)

[Chapter 1: Why a Shipping Container Home?](#)

[Chapter 2: Prepare For Your Container Home](#)

[Chapter 3: Sketch a Floor Plan](#)

[Chapter 4: Buy a Shipping Container](#)

[Chapter 5: Build The Foundation](#)

[Chapter 6: Put a Roof on It](#)

[Chapter 7: Open and Modify Your Container](#)

[Chapter 8: Insulate Your Container Home](#)

[Chapter 9: Put in the Floor](#)

[Chapter 10: Do The Final Touches](#)

[Conclusion](#)

Chapter 1: Why a Shipping Container Home?

Searching for a property that is comfortable, stylish, affordable, and located in a serene environment is a tough call, and finding your dream home can be quite tiresome. That's why you need to build one for yourself—a house that meets all your needs.

Because building traditional homes has become a costly affair, like you, many people are opting for a cheaper way to build their dream home. Shipping container homes are a great option.

But, before you jump into the bandwagon of building shipping container homes or the 'tiny house' movement, you need to understand what they are and what sets them apart from traditional homes.

What are Shipping Container Homes?

Container homes are simply homes made from those steel shipping containers you see everywhere carrying goods on trucks, trains, and ships.

Shipping containers have a standard size of 10ft, 20ft, or 40ft long, 8 feet wide, and 8.6ft tall. We also have others referred to as high cube containers with an extra 12 inches tall, measuring 9.6ft in height.

The tiniest shipping container gives you about 100 square feet of floor space. If you combine eight larger containers, you can make a two-story house of about 1400 square feet, and with several containers, you can construct a huge apartment.

We'll expound on shipping containers sizes and dimensions later. Stay tuned!

Why Are Shipping Containers Being Used To Make Homes?

Well, worldwide, over 11 million containers are ‘out-of-service,’ making them readily available. Besides trendiness, like you, many people want to save money by lowering home construction and maintenance costs.

How Long Do Shipping Container Homes Last?

How long a container home lasts depends on you. They can last for at least 25 years or longer if well maintained and protected on the exterior. You can do this by regularly checking for any rust spots and treating any defects immediately.

Is A Container Home A Good Choice For You?

On top of owning a unique home no one else you know has, a shipping container home has practical benefits or advantages.

Here are the benefits that could help you decide if it’s a good option for you;

Easy to Use and Construct

Because of their tough-looking designs, shipping container houses may seem challenging to change but are actually easy to modify effortlessly. You can build with a mix of 20ft and 40ft containers.

You can also attach several shipping containers to build a larger home with more bedrooms, a second floor, or even a guest house. You can affix doors and windows to the containers and effortlessly change the interior and exterior. The fact that you can stack them on top of each other and assemble them easily while allowing architectural creativity makes them very appealing.

Affordable

Cost reduction is a winning point for container homes. Shipping containers are ready-made structures, and any extra fixtures on them have predictable costs. Because you will not build from scratch per se, it lowers the cost of building materials. Once you learn to build it yourself, you can further lower the cost of labor and modification by employing your DIY skills. Moreover, shipping containers are inexpensive, and modifying them into houses is quite affordable.

A basic completed shipping container home costs around \$10,000 to \$35,000. Larger homes constructed using several shipping containers and extra amenities can range from \$100,000 to \$175,000. That's a far cry from building a traditional home that costs between \$250-300k\$ without factoring in the cost of land, water, sewage, and electrical lines.

So, shipping container homes can cost as much as half the cost of a traditional home. Even if you can afford to build a modest traditional home, adopting container homes enables you to put that extra cash towards upgrading your house design. You can then build your dream house without cutting corners or breaking the bank.

However, you have to be aware and on the lookout for factors that could balloon your budget and overrun the cost of building a shipping container, such as structural engineering and modifications (we'll discuss this later).

Fast Building Time

This is one of the key benefits of building shipping containers homes. Building a traditional house can take up to two years. In contrast, a shipping container home can be ready in 1 month or less. With shipping containers, the house's basic structure is already in place; therefore, all you need to do is acquire and assemble fewer building materials.

The construction process will already have begun by the time the shipping container arrives at your location. This makes the entire building process easier and faster.

Well Designed and Durable

Shipping containers are intended to hold huge cargo safely and securely. Their simple box design also makes them handy for home building because they don't need a lot of re-modeling.

Shipping containers are made with corten steel, aka weathering steel, a tensile metal that is extremely robust, which bestows the containers with a high structural strength that makes it easier to pile one atop the other.

Unlike other forms of steel, corten steel is also low maintenance because when exposed to the outside environment, even without painting, it protects itself by forming a protective oxide layer on its surface to slow down corrosion. So, you can rest assured that your shipping container home is very strong and durable and can withstand even the harshest weather conditions better than traditional home structures.

NOTE THAT: Although the corten steel slows the rusting process, it doesn't completely prevent it. Things like lack of paint, pooled water, localized air pollution, proximity to salt water, etc., can accelerate corrosion. Long story short, if you don't give your home proper attention, maintenance, and care, your shipping container shall rust.

Portability

Given that they are designed for shipping, shipping containers are easy to transport. Their unique size is meant to be carried by large trucks and shipped frequently on roads and highways. So, you can get the containers delivered quickly and effortlessly.

Furthermore, unlike traditional houses, completed container homes are easy to move as much as you want – especially those with a simple design or a single container used. You only need to load it up on a trailer, and you're good to go.

Or, for easier transportation, you can decide to dismantle the home or opt for a mobile container house with wheels.

Upgradable and Re-sellable

You can upgrade your home any time by adding one more container; a 20ft one, for example, gives you an instant 320 square feet of extra living space. You can change the design after a while and give your home a fresh look. It's also easy to resell your container home anytime you wish and have them picked off your land.

Environmental friendly

Since you are recycling waste products of the shipping industry—by repurposing used shipping containers—you are helping the environment by promoting a greener construction alternative. Steel is recyclable; therefore, the steel used to make a shipping container home is 100 percent upcycled without the energy used to scrap and melt down the material.

When you, for example, reuse a 40-foot shipping container, you're up cycling about 3,500 kg of steel. Moreover, you prevent the use of bricks and cement. The cement and bricks industries are among the leading producers of excess carbon dioxide, a greenhouse gas that increases global temperatures.

Of course, you can't make an informed choice without knowing the other side of the story.

The Drawbacks of Shipping Container Homes

Just like other housing options, container homes also have their downsides. You need to be aware of them to know how to navigate them well. They include;

Structural Issues

Yes, shipping containers are very strong, but they have a weak roof. Therefore, you have to install an additional roof to protect your container house specifically from snow. And, if you cut out large doors or windows, you destabilize the structure's strength; you need to reinforce it.

Insulation Issues

Shipping containers are narrow (8ft only) – so they need thin insulation layers like spray foams. To further thicken their insulation, you may have to insulate your container home, even on the exterior and in the most sustainable and eco-friendly way.

Space Limitations

Shipping containers are meant to fit on trucks and trains, so they are limited in space such that even usual furniture can seem too big to fit inside. And standard containers are 8'6" high; therefore, there is less headroom left after installing insulation. However, there is a way to get them as spacious as you want. Just keep reading to know more.

Safety Issues in Used Containers

You may not know what was once inside the used shipping containers. They could be harmless goods, but some could've carried dangerous industrial materials. Plus, their original paints and finishes are for industrial use only – not for residential houses and could contain heavy metals such as lead.

Contractor Concerns

Shipping Container homes are relatively new. Thus, it could be harder to find experienced contractors in some regions, and many of them are not familiar with them. So the need to learn all there is about their construction.

Compliance with Building Codes & Permits

Some municipalities don't have applicable building codes and permits for shipping container structures. You need to check to ensure you comply with the local building regulations.

If you are looking for something more affordable, convenient, permanent, and larger than a trailer home, container homes are a great option away from traditional concrete houses.

However, turning your dream house into reality needs a bit of planning, preparation, and purchases. First, you need to:

Chapter 2: Prepare For Your Container Home

How do you go about it? How do you get started? In short, have a construction plan! Preparing a plan well in advance reduces stress. For DIY containers home builders, a plan is extremely handy. There are lots of nuts and bolts that are obvious but easy to miss in this journey. In short, a plan gets you ready and well-informed on where to start and how to start.

NOTE THAT: If you find yourself stuck at some point in executing your plan, don't worry that you didn't prepare for the problem; fix it immediately. For example, you had planned to install an Air-Conditioner, but way after setting it up, the air-conditioner machine starts vibrating and shaking your whole house.

In such a case, all you need to do is fix it straightaway without prior planning.

The planning process generally involves aspects like what to do and the requirements. Carefully consider and dedicate enough time to each aspect of your plan. So, do proper research.

You need to know at the onset – How will you do that? Then, you can go ahead and gather your resources, write them on paper, or even set your budget.

Sometimes you may need the help of experts to do some things, like electrical wiring, plumbing, welding, etc.; therefore, you need to factor them into your plan.

To make a good plan, you need to understand the process it takes to build a container home;

What is the Process of Building Your Container Home?

This is the entire process it takes to build a structure on your site. Constructing a shipping container home (just like traditional homes) involves several stages such as planning, design development, site preparation, building foundation, and finishing work.

How do you build your container home from start to finish?

Building Construction Steps

1. Acquiring Land or Plot
2. Preparing Estimation and Budget
3. Approaching a Builder
4. Site Preparation And Ground Leveling
5. Foundation building
6. Masonry Work
7. Flooring and or Roofing
8. Electrical and Plumbing
9. Exterior Finishing
10. Internal Finishing

Let's now start examining each element of the construction process in more detail and see how you can adequately prepare for constructing your shipping container home.

Here is a checklist to get you started;

- Decide your priority for your home
- Estimate the square footage
- Secure your land

Set realistic budget expectations

Design your dream home

1: Decide Your Priority For Your Home

Keep in mind these three key areas in your construction: budget, design, and set timeline.

While you want to hit all three marks at once, 1 and 2 often stand out as the top-most priorities for building. So think about it.

Do you desire a modest design on a low-end budget? Do you want your home built a.s.a.p. to escape pressing rental bills? Is using renewable energy an issue for you? Do you have the funds?

Decide early on whether budget, design, or timeline is your top priority; that way, you will know how you'll go about your project from the start.

2: Estimate your square footage

How big do you want your container home to be? Answering this question is the easiest way to estimate your building costs accurately before getting started. If you know nothing about square footage, here are some tactics you can use:

For 40ft high cube containers (8'x40' high cube containers), each having 320sf

- Two containers are fit for a 1 bed/1 bath space.
- Three containers are fit for a 2 bed/1-2 space.
- Four containers are fit for a 3 bed/2-3 space.

You can add extra containers to create a more spacious house.

Now, your next job is to calculate and estimate the available space for placing your container home. Get the actual number. Doing this helps in floor planning, layout, and design.

3: Secure Your Land

After setting your priorities and establishing the size of your home, you need to find an appropriate place to build your dream home.

You don't want to pay more than you have to on designing and building your dream home. That's why I always recommend buying your land before starting the design work. Doing this helps you avoid redoing your design if it fails to fit the site.

Skip this step if you already have a piece of land on which you can build. However, you need to make sure your container home will fit on the land in compliance with all existing zoning restrictions and building codes.

Get the Permits

While you might manage to cut corners during the construction part of the project, you have to go by the book when it comes to getting the initial paperwork for a shipping container home in your chosen area.

Work with an architect and structural engineer to ensure the floor plan you have in mind for your shipping container house is structurally sound. It's advisable to get an architect with knowledge of shipping container homes because building with containers is entirely different than building a typical wooden, steel, or brick building. Also, keep in mind that anything you can put in a custom home, you can put in a container home.

If you don't have your land yet, you can go about it in two ways;

- If your budget is minimal, start by finding your land first. Then you don't have to worry if your design will fit on the land. Once you find an affordable piece of land, go ahead and design your container home around the land.

OR..., at the risk of sounding self-contradictory,

- If your pockets are deep enough, start by designing your building and then look for the land that will accommodate your design. It's a bit hard to find a land that meets your set criterion but doing this will ensure that the land you buy will perfectly suit the home you've designed.

As you search for a plot on which to build your dream home, you need a go-to list of requirements to guide you. This list should include:

- General location of the land
- Size of land
- Cost of the land
- Soil type (clay, sand, etc.)
- Access to water (any streams or wells on site)
- Access to the land from the nearest road
- Proximity to neighbors

Armed with your list of requirements, start searching for your land. A good place you can begin your search is on online real estate listings. Online platforms allow you to compare current and sold-out pieces of land and their sale prices. You can then evaluate different areas and their costs before making a choice.

Once you find a suitable area or neighborhood within your budget, ensure to check the regulations regarding permits for building shipping container homes in that area.

Drive around the neighborhood and check for nonstandard buildings like fixed trailers, log cabins, wooden frame homes, container homes, and steel buildings. This exploration will help you weigh your chances of getting a permit. Even if you don't see any container home, the presence of any nonstandard structure is a good sign that the local zoning embraces unconventional buildings.

TIP: The complexity of your site can affect the overall project cost. For example, a flat grass field is the cheapest option. On the other hand, a site that requires difficult road construction, tree removal, complicated foundation work, etc., increases the costs.

4: Budget for Your Shipping Container Home

A budget helps you allocate set resources to pay for the costs. Budgeting is the most important part of your plan because it shapes the rest of your project.

Estimate cost

Start with setting realistic budget expectations. Approximate how much money your container home will cost before making a budget.

You should ensure every cent you intend to spend on your home is covered in your budget. This should include buying land and the container, design costs, contractor fees (architect, structural engineer, welders, etc.), foundation, internal furnishings and fixtures (lighting, kitchen, and bathroom), etc.

As an example, here is the cost breakdown for a used 40ft DIY shipping container home: consider this a guide in what material to buy first.

Budget Estimates

40' Used Container	\$2,500
Doors & Windows	\$3,200
Insulation	\$2,500
Metal framing	\$700
Electrical fittings	\$1,500
Plumbing	\$1,800
Flooring	\$750
Drywall	\$720
HVAC system	\$900
Cabinets	\$2,200
Counter-tops	\$700
Millwork	\$600
Misc. material	\$500
Primer & Paint	\$250
TOTAL	\$18,820 or roughly \$20,000

NOTE THAT: These estimates are down to basic figures. We have not included exterior work such as exterior sidings, site preparations, roofing, exterior paint, landscaping, septic, and water supply.

This is the bare minimum cost of a completed, livable DIY container home, assuming you have all the tools required. Anything you do above and beyond this is an added cost. If you decide to hire a contractor to build it, it will cost you double the total cost of materials.

TIP: When preparing your budget, it's very important to put some money aside for a contingency budget (unexpected expenses). We recommend reserving a 20% contingency, but you could set aside more money if your construction is complex. For example, let's say you expect to spend a total of \$100,000 on your container home; allocate \$80,000 for your primary budget and reserve \$20,000 for your contingency budget.

5: Design Your Container House

Imagine how you want the inside and outside of your home to look and create your design on a pen on paper or use beginner-friendly design software such as [Shipping Container House Plans 1.1](#), [Live Home3Dpro](#), and [3D ISBU](#).

You can also hire professional architects to design the building for you as long as it's within your budget. To maintain your budget expectations, hire a designer with prior experience building container homes to avoid rehiring another one to fix design errors.

Ensure Design Efficiency.

Design Efficiency means how well your design uses the containers to produce enough living space. The more complex your design, the less efficient it is. For instance, a house with more 'arms' spreading is less efficient (costly) than a centralized space.

Complexity is about how much stacking, cutting, joining, cantilevering, and bridging your design needs. Such aspects may make your house appear unique and comfy, but they also ramp up costs since irregular designs are costlier.

Design an Outdoor Deck Stretching

Having a generous outdoor deck is quite trendy with shipping container homes because it adorns your home and gives you additional outdoor space.

To design and estimate your outdoor deck's size and dimension, you need to consider the available space and the size & dimension of the containers utilized.

How much land space do you have? How many containers are going to spread out? What's left for the stretch of an outdoor deck?

Design the floor for your container home

The design of the floor determines the rest of the design. So, in the next chapter, we will explore different floor plans to give you an idea of how to design your container home's floor;

Chapter 3: Sketch a Floor Plan

Drawing the floor plan is vital to designing your container home. Here are some floor plans you can consider;

1: 481 Sq. Ft. Home

If you live alone, this plan is the perfect fit. It is affordable and space-saving at the same time. This is a 481 sq. ft. home with a single-level construction plan that offers:

- 1 bedroom
- 1 bathroom
- Laundry inside the bathroom
- An open-plan living room
- A kitchen within the living area
- A small dining area in the large living room
- An open and big front deck

The internal living space is 297 sq ft, and the 177 sq ft remaining is for the front deck. The huge front space makes your container house appear larger and more spacious.

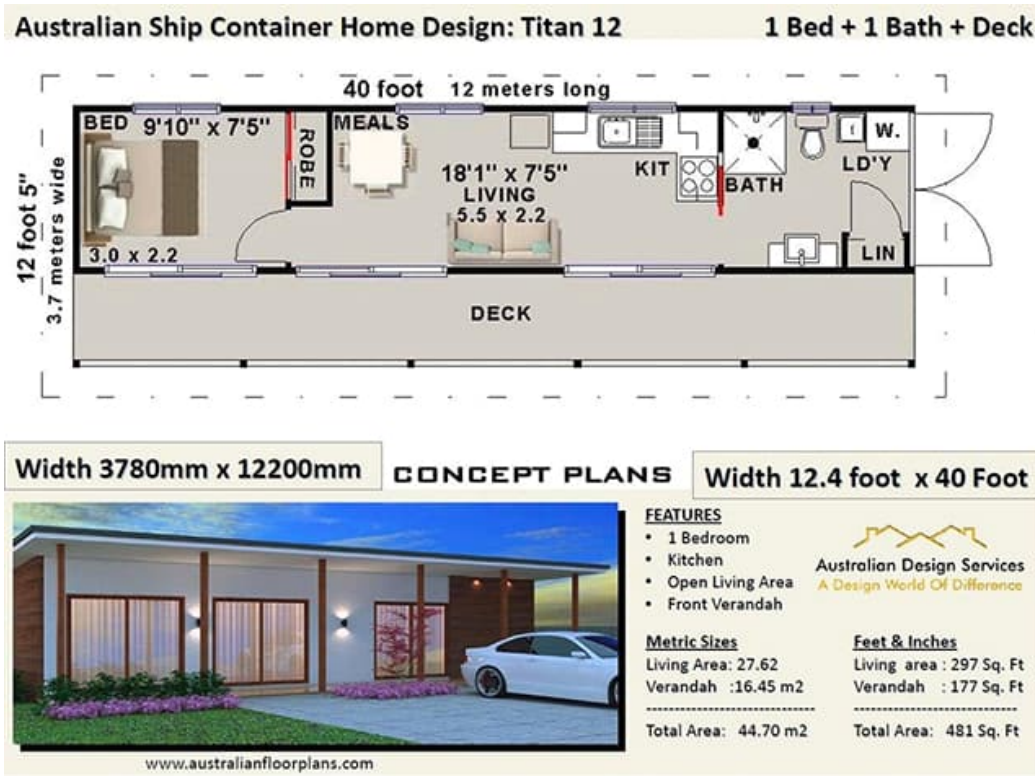

2: 1,200 Sq. Ft Container House Plan

If you fancy roof trusses, this shipping container plan fits you perfectly. It is a single-level plan with 1,202 sq. ft. of living space. However, the internal living space is 726 sq. ft. This house plan includes the following facilities:

- 2 bedrooms with bathrooms
- An additional bathroom you can use as a laundry room
- A large living area
- An open-plan kitchen as part of the large living
- A dining place between the kitchen and living's sitting space.
- A huge front deck

The roof truss design gives your container house a traditional outside look. Then again, the large living area gives your home a modern look from the inside.

1200 Sq. Foot Container Home -Shed Roof Truss 2 Bed + 2 Bath + Large Living

FEATURES

- 2 Bedrooms
- 2 Bathrooms
- Galley Kitchen
- Large Living
- Dining Room
- Front Deck
- Roof Truss Design

Feet & Inches

Bedroom 1 : 15' 12" x 8' 0"
 Bedroom 2 : 15' 12" x 8' 0"
 Living: 16' 10" x 8' 0"
 Kitchen: 9' 10" x 8' 0"
 Bath/Ld'y: 7' 2" x 8' 0"
 Floor Area: 726 Sq Ft
 Deck Area: 476 Sq Ft
 Total Area: 1202 Sq Ft

Width 40'0" x 28' 0"

Metric Sizes

Bedroom 1 : 3.7 x 2.4
 Bedroom 2 : 3.7 x 2.4
 Living: 5.1 x 2.4
 Kitchen: 3.0 x 2.4
 Bath/Ld'y: 2.2 x 2.4
 Floor Area: 67.2m²
 Deck Area: 44.2 m²
 Total Area: 111.48 m²

Width 12192 x 8530mm

CONCEPT PLANS Shipping Container Home www.australianfloorplans.com.au

3: Four Bedroom Container House Plan

If you have a large family, you need a house plan that is comfortable for everyone. This 4 bedroom floor plan includes 4 bedrooms in a relatively small space. It uses three 40 ft. containers and positions them parallel to each other with spaces in between.

The spaces form two under-roof alfresco that connect the entire house. These two parallel containers include two bedrooms, each having a private seating area and accompanying bathrooms. The container in the middle is for the common areas of your house. It features:

- A kitchen

- A vast living area with two seating spaces
- A dining area
- A laundry room

Furthermore, this house plan also has a hut-shaped roof for fitting solar panels. A 10 kW solar panel system fits perfectly on this roof. This house, therefore, allows you to live off-grid and save a lot on your energy bills.



4: 840 Sq. Ft Container House Plan

This 840 sq. ft. container home design gives you ample internal living room of 473 sq. ft. This design involves joining 3 shipping containers with a single floor. It features;

- 2 Bedrooms

- An open- kitchen with a dining area
- A large bathroom
- A large living room
- A porch
- An Alfresco

A shipping container home design that has an Alfresco element allows you and your loved ones to enjoy a meal in the heart of nature.



5: 2 Bedroom Container Home Plan

This plan gives you a modern-looking two-bedroom container home built with 3 shipping containers. It has a 441 sq. ft. internal living space and a 290 sq. ft. deck area. This gives you a house with a space of 731 sq. ft. in total. This single floor plan features:

- 2 bedrooms
- Laundry, as part of one of these bathrooms
- 2 bathrooms
- A large open-plan living area with a comfy sitting space
- An open and large front deck
- A kitchen as part of the large living

Australian Container Home Design: 68 Sea Eagle

2 Bed + 2 Bath



Width 10.93m x 7.40m

Width 35' x 24' 3"

Metric Sizes

Living Area: 41.0 m2
Total Area: 68.0 m2

Feet & Inches

Living 441 sq foot
Deck 290 sq foot
Total 731 sq foot

FEATURES

- 2 Bedroom
- 2 Bathroom + Laundry
- Kitchen
- Living Room
- Alfresco / Deck



Australian Design Services
A Design World Of Difference

www.australianfloorplans.com

PRELIMINARY SET OF PLANS

Australian Container Home Design: 68 Sea Eagle

2 Bed + 2 Bath



Width 10.93m x 7.40m

Width 35' x 24' 3"

Metric Sizes

Living Area: 41.0 m2
Total Area: 68.0 m2

FEATURES

- 2 Bedroom
- 2 Bathroom + Laundry



Australian Design Services

Feet & Inches
Living 441 sq foot
Deck 290 sq foot

Total 731 sq foot

- Kitchen
- Living Room
- Alfresco / Deck

A Design World Of Difference

www.australianfloorplans.com

PRELIMINARY SET OF PLANS

6: Container Home Plan with Two Living Areas

This design utilizes two 20ft containers and one 40ft shipping container. The two 20ft shipping containers attach to either side of the 40ft one leaving a space in between. A roof is put over them to form two alfresco. The middle shipping container features a large living area with two sitting areas and a dining room. It also offers a big kitchen with a pantry plus a bathroom with a laundry area. The internal area of this home is 319 sq. ft.

The two 20ft containers are customized to create two large bedrooms, each having a private bathroom with a shower. These bedrooms also have a comfortable sitting space of 158 sq. ft. On top of this, there are two open deck areas in front of the house and a tiny sitting-cum-dining space inside the alfresco. With this design, you get 566 sq ft of total space.

3 x Shipping Containers 2 Bedroom Design: 2 Bed + 2 Bath + 2 Living Areas

Feet & Inches
 20 Ft. CONTAINER 1: 158 Sq. Ft
 40 Ft. CONTAINER 2: 319 Sq. Ft
 20 Ft. CONTAINER 2: 158 Sq. Ft
 Deck Area : 566 Sq. Ft

 Total Area: 1202 Sq. Ft

Metric Sizes
 20 Ft. CONTAINER 1: 14.7 m²
 40 Ft. CONTAINER 2: 29.7 m²
 20 Ft. CONTAINER 2: 14.7 m²
 Deck Area : 52.6 m²

 Total Area: 111.7 m²

FEATURES

- 2 Bedroom
- 2 Bathrooms
- 2 Living Areas
- Kitchen + Meals
- Alfresco
- Open Living Area
- Large Deck Area
- 2 Solar Roofs

Australian Design Services
 A Design World Of Difference
www.australianfloorplans.com.au

CONCEPT & PERMIT PLANS

Width 12114 x 12192mm **Width 39'9" x 40'0"**

Once done designing the floor of your home, you can move to the next step (of buying the container)

Before doing that, make sure you have met all the required building codes and acquired the necessary permits and plan approvals from your area authorities. Some areas are not shipping container home friendly at all. You don't want to build your dream home only for the authorities to force you to tow it away or move it somewhere else.

Once you have the building permits and permissions you need and are fully compliant with the local and state policies, you can then:

Chapter 4: Buy a Shipping Container

Choose the right shipping container that perfectly fits your chosen design. For example, if your design requires high ceilings, you need to buy high cube containers.

Choosing the right container to buy is no easy task. You need some basic knowledge about the different types of containers, allowing you to make an informed choice.

Your local container dealer may not stock all kinds of shipping containers, and you may need to shop around to get the specific container you want. However, dealers occasionally run promotions on some types of containers. Lucky you if it's possible to adjust your design to accommodate the discounted container. You can then use the extra cash for other house upgrades. On the other hand, if money is not one of your concerns, just pick the container you want and ship it to your site.

As we mentioned earlier, containers come in different sizes and dimensions. Here are several types of shipping containers;

Common Types of Containers

We'll focus on the most common types of shipping containers. The ones you are likely to find for sale. They are the dry containers and water-tight containers you know and love. These shipping containers are very versatile and usable in many ways.

See the images below.

		10' CONTAINER	20' CONTAINER	40' CONTAINER	40' HIGH CUBE	45' HIGH CUBE
Door	WIDTH	7' 8.125"	7' 8.125"	7' 8.125"	7' 6.00"	7' 6.00"
	HEIGHT	7' 5.75"	7' 5.75"	7' 5.75"	8' 5.00"	8' 5.00"
External	LENGTH	9' 10.50"	19' 10.50"	40' 0.00"	40' 0.00"	45' 0.00"
	WIDTH	8' 0.00"	8' 0.00"	8' 0.00"	8' 0.00"	8' 0.00"
	HEIGHT	8' 6.00"	8' 6.00"	8' 6.00"	9' 6.00"	9' 6.00"
Internal	LENGTH	8' 8.81"	18' 8.81"	39' 5.70"	39' 4.00"	44' 4.00"
	WIDTH	7' 8.59"	7' 8.59"	7' 8.59"	7' 7.00"	7' 7.00"
	HEIGHT	7' 9.89"	7' 9.89"	7' 9.89"	8' 9.00"	8' 9.00"
Capacity	CUBIC VOLUME	536.3 ft ³	1,169 ft ³	2,385 ft ³	2,660 ft ³	3,040 ft ³
	EMPTY WEIGHT	2,870 lbs	4,850 lbs	8,380 lbs	8,598 lbs	10,580 lbs
	LOAD CAPACITY	24,910 lbs	61,289 lbs	57,759 lbs	58,598 lbs	55,559 lbs

The 20ft Shipping Container

The standard 20ft shipping containers are popular because they are easy to maneuver and lighter in weight. Some people make tiny cabins with a single 20ft container, but these containers are also usable as part of a larger building.

20ft containers are cheaper than the 40ft alternatives, but their price per square foot is costlier. For the size of an equivalent building, you'd need

two more 20ft containers. So even if you save money on each container, you're actually spending more on the total project costs.

So unless your design demands 20ft containers, using 40ft boxes is better if you want more floor space.

Sometimes you'll see the term TEU (Twenty-foot Equivalent Unit) on containers; don't worry, this is just a measurement for determining the quantity of goods that could fit in a 20ft container.



20ft High Cube

20ft high cube shipping containers are just like standard 20ft shipping containers but with only more room of 12 inches in height. This makes it possible for interior insulation and light fixtures while having a normal ceiling height. Higher ceilings open up your whole design and generally make your home's interior feel roomier.

20ft Reefer Container



Otherwise called a reefer container, this is your usual 20ft container with insulation. If you intend to insulate, a reefer could be a shortcut as long as it matches your chosen design. Since insulation helps keep your home in comfortable temperatures, it is necessary. Therefore, if you can get a good deal and navigate the tradeoffs, buying a refrigerated container could help you save the money meant for insulation.

But, in most cases, reefers have an industrial refrigeration unit you need to get rid of and then patch over the big hole it leaves on your container. Therefore, before buying refrigerated containers, know their pros and cons. Yes, they have more headroom and built-in insulation, but on the downside, they make it harder to embed your wires behind your ceiling as with the regular containers where you can do insulation later after setting up your wiring.

40ft Shipping Containers



These are the most commonly used shipping containers. They are big enough to split up into several rooms (say, a one-bedroom home) and are also combinable to build a house of any size. Like the general-purpose 20ft one, 40ft Shipping Containers have a lower ceiling height, and interior insulation could reduce your headroom.

If your design needs many 20ft containers, you need to re-check your needs. You could achieve your goal using 40-ft containers instead of splitting them up. A 40-ft container is a go-to size for many people because it is more economical in the end.

40ft General Purpose High Cube



A high cube 40ft container gives you a bit more height, with the same floor area as the usual 40ft container. This gives you the extra room for insulation, fixtures, and wiring, as you maintain 8ft interior ceiling height. The additional foot may not be worth much for other structures, but with container homes, it means extra comfort and more room for your stuff.

40ft Refrigerated (reefer) Containers

With a 40ft reefer container, you enjoy the benefits of the dry 40ft shipping container and extra built-in insulation.

45ft General Purpose High Cube Container



The 45ft containers have 2.5ft extensions on either end of the container with corner castings. This allows the 45ft containers to stack easier with the 40ft containers. They are also high-cubes with the extra foot height. The extra 5ft length also gives you much bigger rooms to easily build a two-bedroom unit.

Regardless of the type of container you want to buy, you should decide whether to buy a new container, a used container, or a one-trip container.

- New containers have the upside of being in perfect condition and easy to find and purchase. However, they are much more expensive

and less eco-friendly than reclaimed containers.

- One-trip containers are formerly new containers used for just a single shipment, making purchasing one-trip containers a great value for money, not to mention the good container condition. The major disadvantage is they're less available due to their high demand.
- Used containers give you the best value for money—as long as you purchase those in good condition. But, it is in your best interest to inspect containers thoroughly before purchasing. You must see the shipping container with eyes before buying them.

BEWARE! Used containers can be made to look in good condition on camera, but some dishonest dealers could hide infested floorboards or corrosion. Both of these damages are expensive and hard to repair.

When inspecting the condition of a used container, you should:

- Walk around the outside of the container and check for any signs of major dents and corrosion.
- Check the key support beams of the container.
- Check underneath the container for any defects.
- Check the roof of the container. Most people don't inspect the container roof, but you should because used containers stay outside for a long time and could suffer extreme corrosion owing to stagnant rainwater.
- Decide whether you are building it yourself or hiring a contractor.

One more thing: the easiest container to affix huge glass doors is the open side ones shown below.



For a DIY, you need to prepare all the necessary tools and equipment. If you have previously built something, you may have several of the needed tools, excluding welders, grinders, and lifting equipment.

If you are going to hire contractors, organize yourself, research, and make plans long before starting the construction. Narrow down your list of contractors to a convenient list of 2-3 people. Interview the contractors and request them to let you visit previous buildings or homes they have built. This entire interview process could take three months. So, consider your time frame for completing your home before you opt to hire an expert.

Once you have chosen the right containers for your home, go ahead and place an order.

Now that you have the floor plan, the right shipping container, and have decided where to build your home, now think about the ground itself and the kind of foundation you want to use for your container home.

Chapter 5: Build The Foundation

You need to think about what you're going to place your shipping container on (the foundation) to keep it off the ground. A foundation keeps your container home stable and square and elevates it from the ground, keeping it safe from moisture and corrosion.

If you don't put your shipping container on a leveled-off surface, you may have issues opening and closing the doors, especially when you have already stuffed your container.

Do you Need a Foundation for your Shipping Container Home?

The soil on your site is a key factor in determining whether or not your home needs a foundation. As a general rule, you may not need a foundation if the ground you're placing your container on is stable, level, and dry. Otherwise, if your site is overly wet or has clay soil, building a strong foundation is a must-do to avoid stability issues like sinking and shifting, plus corrosion.

Your choice of foundation depends on your personal preferences and what your structure requires. It's best to consult an expert, especially if you plan on building with multiple shipping containers.

Common foundations you can probably consider are wooden beams, concrete piers, concrete slabs, and concrete footings.

But, before you embark on the actual foundation, here are key land preparation steps you need to take;

Step 1: Plan and Layout

Before getting your hands dirty, make a layout plan that considers your floor plan. The plan doesn't need to be complex and up-to-scale like those

drawings of civil engineers. Just make a rough sketch of the ground of the container home structure you want to build. Remember to indicate the dimensions, including the length, width, and height of each container you intend to use, along with the spacing between them.

NOTE: Plan and layout creation requires a complete understanding of the entire building procedure. Hence, even though this is the first step, only create the layout plan after going through all the steps described in this book.

Also, while calculating the length and width of the foundation, remember to figure in the width of each hole or trench you will have to dig and the spacing between two adjacent holes/trenches.

Step 2: Land Clearing and Perimeter Setup

Get the construction site ready. Identify the spot where you will build your home and start picking stones, plastic pieces of wood, glass bottles, weeds, large grass, etc. Level any undulations on the ground.

Now set up a perimeter for your house, using wooden posts and strings. Put a wooden post in one corner of your plot. Take a measuring tape, measure the length of your structure, and install another wooden post. Take your construction string, tie it to the first post, extend it to the second post and wind the string around it many times.

Now, at right angles to the second post, measure the breadth of your structure, and put the 3rd post at that spot. Wind the string to this post. Once more, measure the length and width, then wind the string on it until you get back to your first post. Tie the string on the final post and cut it from the rest.

Step 3: Build the Foundation

There are many foundations to choose from, but we shall expound on the most beginner-friendly ones.

They are as follows;

1: Wooden Beam Footings



Using wooden beams for a shipping container foundation is a beginner-friendly and affordable option because:

- You need less material; just beams to support the four corners of the container. However, for extra stability, you can support the middle points on the lengthy side of the beams.
- Unlike concrete footing and slabs, you can install the beams shortly before your container arrives with much less site preparation.

NOTE THAT: You need to put a gravel bed under the wooden beams to help with drainage, keep the beams dry and stop premature rotting. Keeping the container home at least 15cm (about 6 inches) off the ground allows enough air circulation.

Materials Required:

- Treated 4"x4" Wood beams, rail road ties, or similar skids.

- Loose stones or gravel for the gravel bed.
- Spade shovel, gloves, etc.

How to Build Wood Beam Foundations Step By Step

STEP 1: Lay a gravel Bed in line with your container home design and dimensions.

- Mark your foundation area with a rope or spray paint, keeping in mind your container home design and dimensions.
- Use the spade to dig out 4" to 6" (10-15cm deep) of soil to make a pit. As you dig the edges, keep your spade vertical to ensure uniformity. Use a measuring tape to measure the pit.
- Smoothen out the foundation with a rake to make it even.
- Compact the soil using a hand stamper (a long pole with a flat metal base) to stabilize the foundation base.
- Lay your stone base; gather enough crushed stones that can fill 2-3" of your pit; pour it out into the pit. Level it out with a steel rake.
- Spray the stones with lots of water using a hose pipe or a watering can.
- Compact the stones using the stamper. Just slam it in!
- Now put a fabric to cover the stones to keep weeds at bay, improve drainage, and stop any loose stone from shifting. Since the fabric comes in strips, buy enough to cover the entire pit and overlap any cut pieces at 10-20cm.
- Also, make sure any fabric hanging outside the edges of your pit is cut out. Put spikes, heavy stones, or pins at the corners of the pit to keep the fabric in place if your place is too windy.
- Fill the remaining part of your pit with gravel and then spread it out with your steel rake. Finally, you have your gravel bed!

STEP 2: Lay out your wooden beams along the gravel bed's length and width.



Here is a link on how to make a [Wooden Beam Foundation Step-By-Step](#)

Remember your container should be at least 6" off the ground. You can install skirting or fencing later if you live in an area with small animals that may take residence under your container home

STEP 3: Place the container: Once your container arrives, place it on the beams or tiers; adjust it accordingly to ensure it's steady.

2: Pier Foundation

Pier foundations are very popular for container homes because they're also DIY friendly, relatively cheap, and quick to construct. You can make the piers using concrete wood or posts. So, pier foundations can be simply built by cardboard tubes filled with cement then put into hand-dug holes. But, for

supporting much greater loads like a huge house, you need more complex piers.



This picture shows a concrete pier foundation that uses concrete blocks (piers) measuring 50 cm X 50 cm X 50 cm with steel inside to add to their strength and ease tension. The concrete blocks are placed at each corner of the container.

The number and size of piers to use depends on the load you intend to put on them and the soil type on site. For larger 40-foot containers, you need to put two piers in the middle of each side of the container.

Here is a link on how to make a concrete pier [step-by-step](#)

Pros

- It saves time and money since you don't excavate a lot. You just need to dig a ground of 50cm X 50 cm X 50 cm per corner. Compared to the slab foundation where you excavate an entire ground under the container.
- DIY friendly; you don't need expensive, complicated equipment.

- Environmental friendly; piers cause minimal soil disruption. Using just a shovel, you can excavate the soil without bothering any roots and soil organisms too much. And, in case you want to relocate your container home, the site is easily restored to its natural state.

Pier foundation is the most recommended for DIY container home builders.

NOTE THAT: The wooden beam and piers are the most beginner-friendly foundations for your container home project.

The other two options below are cost-effective but best for builders with some skills of working with cement;

3: Concrete Slab Foundations for Shipping Containers

If the ground is soft and you have enough money, use concrete slabs but be prepared for a lot of digging.



The photo on the left shows a concrete slab foundation onto which you place containers.

The slab foundation should be a bit larger than your home's footprint.

For two 40-foot shipping containers, your concrete slab foundation should be 42 feet long by 18 feet wide. This gives you an overhanging area around your shipping container's perimeter.

Pros of Slab Foundations

- Provide a solid base; there are no gaps in the foundation, which keeps termites at bay.

Cons

- They need lots of space to excavate, which costs a lot. You need to hire a crew to do all the digging and use a lot of materials.
- They are great in warmer climates but freezing cold during winter.
- Harder to access utility lines. Should your water pipes leak, you have to cut the concrete.

If money, time, and space, aren't an issue, go for a concrete slab. For the DIY container home, remember to design your slab foundation, considering that the weight of the container rests heavily on the corners and edges of the foundation.

4: Concrete Footings for Shipping Containers



If your container home will stay in position for a long time and your budget is tight, concrete footings could be for you rather than the concrete slabs. But don't be fooled. While concrete footings could be a more cost-effective option, they need meticulous planning and serious attention to detail, so ensure you have enough time to spend on getting it right.

A few things you need to consider when planning to use concrete footings are;

- How deep should the footings be? Is your ground prone to frost?
- How large should the footings be?
- How much space do you need for your home? Measure and mark the area, place stakes and tie them off to enhance your visualization for the space needed.
- How soon will your container arrive? You need to complete the footings several weeks before your container arrives. This is where you need an expert to tell you how much time the concrete will take to cure.

Once you have a solid foundation, sit your shipping container on it, and then put on a roof. Next!

Chapter 6: Put a Roof on It

Whether or not to put a roof above your container home depends on your personal style and the money in your pockets. Yes, no roof means fewer upfront expenses for you, but in the long run, placing a roof on your container and insulating it could save you money spent on energy bills (from air conditioners, warmers, and fans) and rust-generated maintenance costs.

Also, installing a roof with an overhang stops the rainwater from running down your windows—therefore, you don't need a drip bar over the windows.

Here are the different roof styles to choose from;

1: A Shed Roof



Three 20-foot shipping containers with panels

A shed roof, as shown above, is simply a sloped roof. This roof is cheap and fast to build. It's popular especially because it makes it easy to install solar panels to help with energy-saving. It is also extremely cheap and easy to build for DIY home projects. Within a couple of days, you'll have completed your roof.

How to Make a Shed Roof

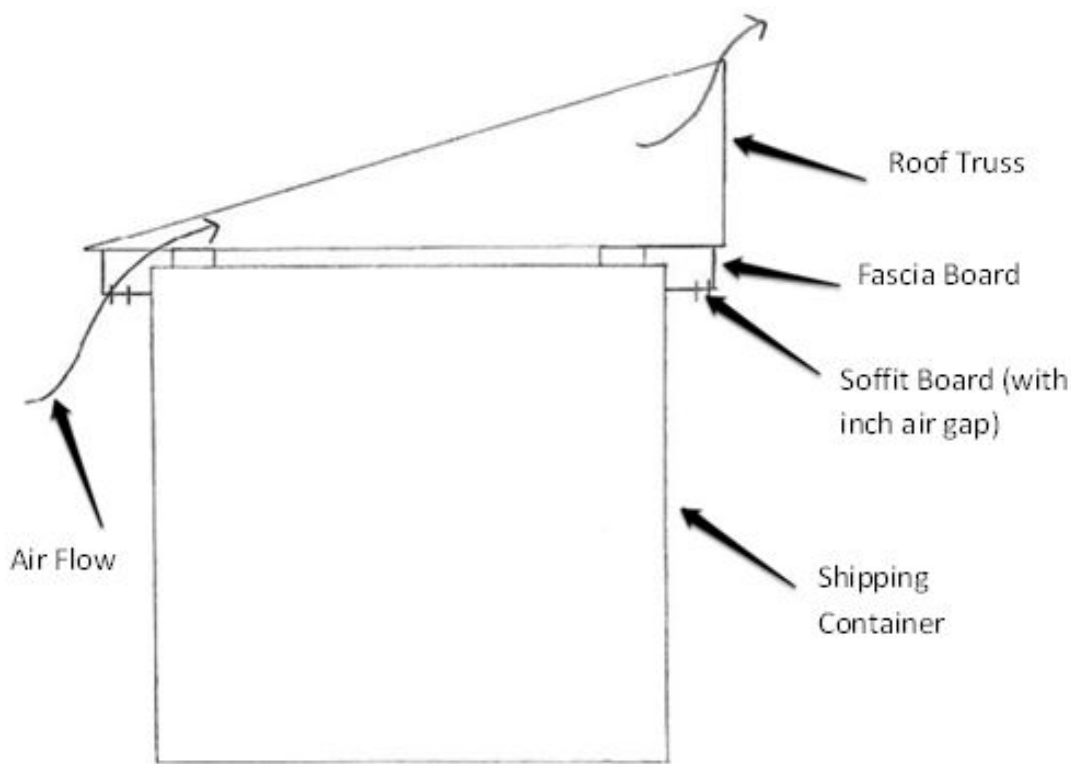

Here are the stages:

- Weld steel plates across the length of each side of your shipping container.
- Attach a wooden beam to the steel plates on both sides.
- Screw trusses (a framework with posts, rafters, and struts that support the roof) onto the beam. Now, you have your roof's basic structure

- Attach purlins or steel bars across the trusses for structural support. Consulting a structural engineer would be a good idea at this point. Ensure the trusses overhang your container for enough ventilation.
- Put a fascia board beneath your trusses. Leaving an inch of air gap at the middle, cover it with wire mesh for good airflow that prevents heat traps and condensation that cause rust.
- Cover the roof using steel sheets, galvanized metal sheets or shingles.

2: Gable Roof



Your second option is installing a gable-styled roof, like the one shown above. This style is probably what comes to mind when you imagine a traditional home. It has a unique triangle look.

A gable roof is honored for its slanted design that provides great water drainage. So with fewer leaks, your roof's lifespan is enhanced. Moreover, the gable roof gives you more ceiling space than other roofing styles.

How to Install a Gable Roof

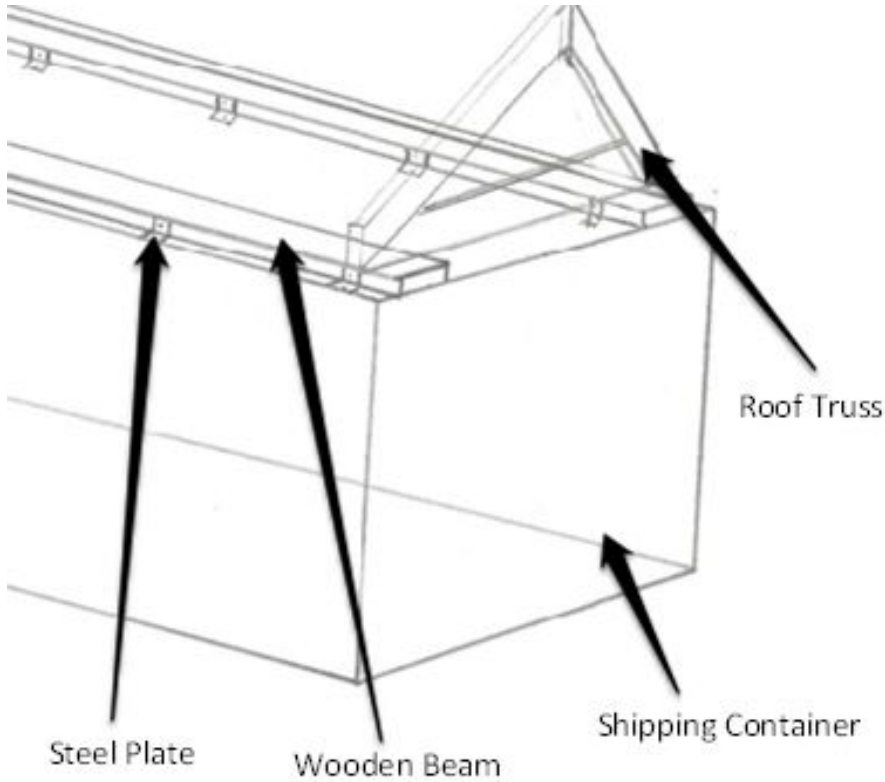
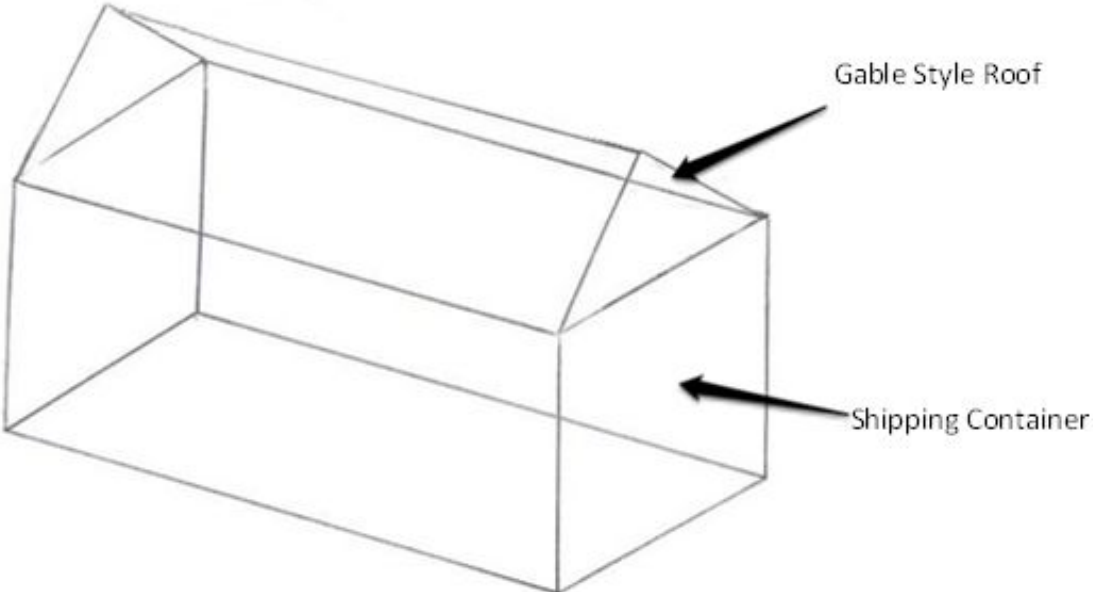

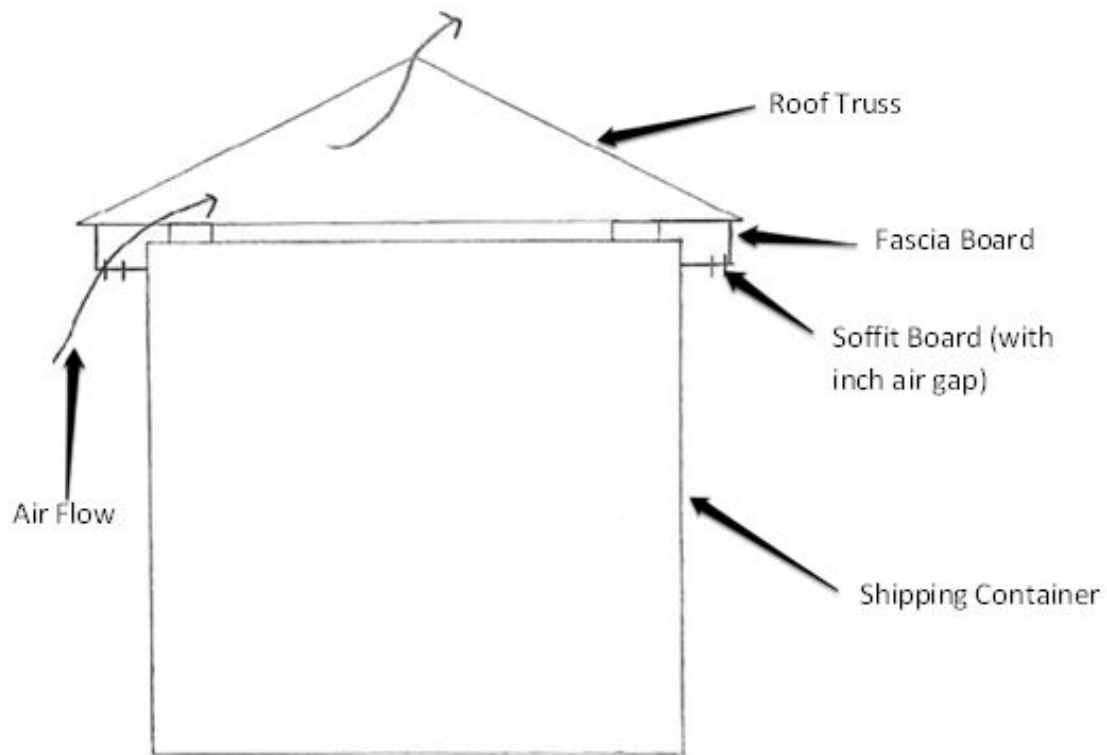

Constructing a gable roof follows the same stages of installing a shed roof. Just make sure the roof is triangular and well ventilated at the end of the gable by cutting slots out of the roofing steel plates using a disc cutter to allow air to pass through the roof.

3: Flat Roof

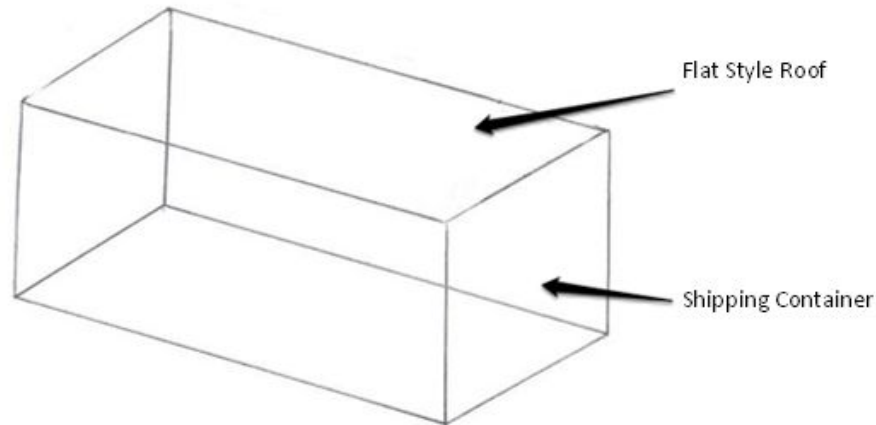

The picture above shows a flat roof with a garden on top of it.

Containers have a flat rooftop, and for many people, this is good enough a roof. But, although it's cheaper to leave it as is, doing so leaves your roof vulnerable to water pooling.

A flat roof can be maintained by simply placing a flat cover on the container roof.

If you choose not to roof your container home, you should quickly install a safety barrier. How?

Lay a tarpaulin sheet onto the container's roof.

Cover it with rolls of asphalt.

This layer gives your roof defense against dampness. You can plant your garden on it if you like.

Regardless of what roofing style you choose, consult an experienced structural engineer to help you calculate your roof's load-bearing requirements and maintain safety. Load-bearing weight is the maximum weight your container roof can hold without collapsing. This figure varies with design, style, location, and weather.

Once you have chosen your roof design and put the roof on your container home, move to the next step. Modify the container to suit your home design.

Chapter 7: Open and Modify Your Container

Changing a box-shaped shipping container into a livable space requires some modifications that take a bit of effort. These modifications include:

- Cutting out openings for sidewalls, doors, windows, and stairs.
- Wallcoverings, painting, and flooring finishes.
- Shelving, installing work surfaces and lockers.

Take your design and identify the spots for windows, stairs, doors, electrical outlets, plumbing fixtures, and interior partitions. If you didn't factor them into your design beforehand, draw a detailed plan with their exact locations and measurements.

Go to your handyman's toolbox and look for the following tools in your arsenal;

- Permanent marker (Sharpie is best)
- All-saw/skill saw with quality heavy steel cutting blades or a plasma cutter
- A torch if needed

If you don't have these tools, rent them from hardware stores or neighbors.

Get ready for heavy-duty work. But, before you embark on the job, make sure you wear the proper protective gear for working with cutting tools such as;

- A pair of heavy leather gloves (like those worn by welders) to avoid cuts from the sharp edges.
- Eye protection glasses; to keep sparks and metal shavings away from your eyes.

- Good hearing protection; to mute your tool's loud noise,
- Heavy long pants and a long-sleeve shirt to avoid cuts on your legs and arms.

Wearing these gears may not be cool at all, but it's much better than having metal shavings land on you.

NOTE: Container steel sheets are 1/8" thick, so the cut-out piece is pretty heavy. Be careful at the end of your cut and ensure the heavy metal piece with razor-sharp edges doesn't fall on you.

Steps You Should Follow When Modifying The Container

Step 1: Draw the edges of all the openings on the container using the marker.

Step 2: Cut out openings for vents, windows, and doors to make the container accessible and allow sufficient daylight and good ventilation. Cutting steel is not your usual cup of tea, so make sure your saws have quality blades to avoid unnecessary frustrations.

Drill holes on the edge of the line of your marked opening; ensure the holes are big enough to fit the saw blade. Insert the saw blade in the hole and start cutting along that line.

You can also use a skill saw with a good metal cutting blade. Place the blade over your mark and line it up. Elevate the rear of your skill saw enough for the blade to get off the container's surface. Start the saw blade, easing it slowly down your mark. Start cutting through the steel along your line. When you get to the corners, repeat this because a skill saw doesn't make turns. Don't worry if you wander a little off your line when cutting. You can correct this later. A plasma cutter is better than saws and best for cutting corners.

Step 3: Reinforce with steel: When you cut out openings on the container, you weaken its structural strength. You need to reinforce the structure by welding additional steel around the openings to offset the subtracted metal and provide sufficient surface area for attaching the door and window frames. However, to keep the cost low, avoid over modification.

Step 4: Fill Remaining Gaps.

Once you cut out the container windows or doors, you'll notice a gap left all-round the edges of the cutout areas. To prevent future water leakage, you should fix this using metal filler or silicon to seal off the gaps around the frames.

NOTE: You can add a water barrier above all openings by welding a flat steel bar on the top points of the window or door frame. Doing this stops rainwater from falling from the side of the shipping container. However, this is unnecessary if you have a generous overhanging roof.

Step 5: Framing And Partitions

Once you have made your container watertight, your next step is partitioning and framing it. Adding interior partitions or leaving the space open is optional. But, if your home's interior design calls for several partitions or uses more than two shipping containers, then framing is best.

Due to the tough corten steel, it's not easy to directly attach anything to the container walls. Framing the interior of your container is very important because it allows for the easy installation of things like insulation, plasterboards, or wallboards. If you skip framing the interior, you'll have to drill directly onto the container, which is a bad idea.

However, if your home design doesn't need interior framing at all, skip it. But, remember that for the container to stay watertight, screwing boards

directly on its surface is not advisable.

Attach studs to your container wall's partitions using a welding tool and cover the studs with magnesium oxide drywall. Pre-treated 2×2 timber studs are the best for framing the container walls and installing interior partitions.

Cover all the joints with the oxide and drywall tape, smoothen it using sandpaper or an orbital sander, and put holes on the wall for electrical fixtures and plumbing. Install the socket bases plus other electrical outlets. Also, install countertops and cabinetry.

Step 6: Electrical Wiring And Plumbing

Once done with wall framing and partitions, install the mechanical and electrical components.

You have two options; either you connect to the grid or go off-grid.

Connecting to the national grid allows you to enjoy unlimited access to electrical energy. Aside from reducing bills, it's a painless elegant option. However, you need to find a certified electrician to do the job and then apply to the local Power Utility Company to get the meter (the analog or smart meter).

If your container house is in your residence, you may DIY-connect using a permanent underground cable certified for outdoor use and has the right power rating. Either way, you should adhere to the relevant requirements for safety.

Off-grid, your container home is powered by wind, solar, hydro DC power generated by a diesel generator and an inverter. Once you can generate your own electrical power, you escape the inspections and monthly bills.

However, you should follow the NEC regulations and safety standards for converting DC to AC power and surge protecting your power system.

All the electrical wiring, plumbing, air conditioning, and cabling should be in place before installing insulation. As you can see, this is too technical.

It's wise to hire qualified experts to do the job professionally and avoid disasters. Plus, it will be easy for you to get an occupation certificate.

Solar Panels and Rainwater Catchment

If you desire to live completely off-grid, buy a small solar PV system to power your container home. Remember to contract a professional to do the wiring and installation.

Also, adding a gutter system on your container roof and directing the rainwater into a tank near your home is your easy way to a steady, sustainable source of water for your household. You can use a small solar pump to pump that stored water into sinks, bathrooms, and your toilet system.

Installing Air Conditioner Inside Shipping Container Home

Use a centralized HVAC mini-split system to control your home's indoor temperature because it's easy to install, use, and cost-effective.

As for installing Air-Condition outdoor, mount the ventilation unit on the exterior of the container wall with rust-proofed bolts resting on rubber washers to reduce vibrations and noise.

Without suitable ventilation, a good HVAC system, and proper insulation, the inside of a bare-metal container feels like a tropical rainforest: very hot during summer and freezing-cold during winter. An un-insulated container

is also vulnerable to condensation when hot air touches the cold metal, causing mold, rust, and poor air quality.

Now that you have the foundation, windows, doors, and a roof in place, you can start working on finishing the interior. Insulate your floor, walls, and ceiling.

Let's first look at various types of beginner-friendly insulation for the container!

Chapter 8: Insulate Your Container Home

Having a well-insulated home can't be over-emphasized. Properly sized and well-installed insulation keeps you cooler in summer and warmer in winter, reduces energy usage, and saves you money spent on energy bills.

Surprisingly, most container home builders overlook insulation in their construction plan. But, much like your home's basement, attic, or main structure, insulation is the key to ensuring control over your shipping container's home temperature and humidity.

You may choose to skip insulation to save a few coins, but you could regret it later when your container home starts to overheat and rust away. You could end up spending more cash on heating and cooling than you would have if you had insulated your home earlier on.

How To Go About It

You can insulate your container house on the inside, outside, or both sides. Although most container homes owners only insulate on the inside, consider insulating the outside to preserve the limited container space. However, finding the right way to insulate your container home can be a bit challenging.

Consider these 4 key aspects before you make your choice of insulation.

- Ease of installation,
- Cost
- Product performance
- Climatic conditions

Let's now look at the various insulation methods for container homes.

Types of Insulations

To help you make an informed choice, here are some common types of insulations you'll find out there and their pros and cons.

Spray Foam Insulation

Spray foam has a high R-value (the higher the R-value, the more effective the insulation is at preventing heat transfer) and is also very flexible since you can spray them in gaps of any size.

You can use it on your container home's interior and exterior walls. However, Spray foam is more expensive than other insulations, very messy to work with, and takes longer to install. Additionally, inhaling these chemicals can give you respiratory problems and harm the environment. Spray foam insulation also requires a pro, making it not very DIY friendly.

EPS Foam Panel insulation

This insulation is lightweight, water-resistant, cost-effective, rigid, compact, and has very high R-values. It's strong enough to withstand load and tension. It can also be glued directly on your container sidewalls since it's not that thick. With glue, a utility knife, and caulk, you are good to go.

Fiberglass Insulation

Fiberglass insulation is just plastic with tiny glass fibers. It's DIY friendly, very popular, and mainly used between studs, beams, and joists of unfinished floors, walls, and ceilings.

Although affordable and readily available, its water absorbent is prone to mold and rot and offers poor indoor air quality. It also has small particles

that cause skin irritation and respiratory ailments. Unfortunately, although popular, fiberglass insulation is not well installed in many homes.

Rock-Wool Insulation

Rock wool, aka mineral wool, is made of—that's right—rocks pressed into batts that are soundproof and fire-resistant. Rock-wool insulation is becoming very popular as a fiberglass alternative for use on walls, ceilings, floors, crawlspaces, and attics because the batts are easy to install with unique features such as:

- Natural and sustainable material that is 75 percent recyclable
- High heat resistant Non-combustible up to 1,400 degrees
- Highly water-resistant
- Exceptional sound-deadening ability
- Higher R-value than fiberglass
- Long-lasting
- Allows moisture outflow (preventing molds and mildew)
- Thick, firm batts that can be affixed without stapling

They are well-suited for the chilly rooms in the house and those needing soundproofing, like study rooms and music studios.

Before choosing the perfect insulation for your container home, you need to decide how you will build your walls. If you are attaching several containers for a multi-container home, you have enough space to play with. But since the tiny homes of one or two containers have limited space, it's best to insulate on the exterior and then cover it with some external cladding.

Exterior Insulation and Cladding

Often, the advantages of exterior insulation outweigh its cost and technical complexity. First, you get more internal space (especially when the insulation must be thick due to the extremely cold climate).

Secondly, insulating the outer side of walls eliminates the vapor condensation effect—quite a difficult task with interior insulation. Thirdly, you can add your personal style and give your home a unique architectural look differentiating it from the “pack.”

When exterior cladding your container house, you should consider aesthetics (texture, colors, finish, design, etc.), the cost (labor and materials), durability, and maintenance needs.

Although you can finish your container home using the materials normally used on traditional homes, the best exterior finishes for your container home are:

Modern

For a modern look, use steel. A steel siding mimics the look of many commercial buildings. Using vinyl together with metal siding gives the same effect.

Rustic

Wood cladding containers are trending lately as a way of “getting closer to nature.”

Wood cladding gives your shipping container home a cabin-like feel. If you want a cottage or just a home-away-from-home, a rustic look is perfect for you. Log sidings have a similar look as wood cladding. Bamboo is also perfect for a finish with a rustic feel.

Painted or stained (using natural colors) timber gives your home a classy elegance that blends with urban and countryside settings. Plus timber is eco-friendly and renewable!

The popular woods used for exterior cladding are pine, redwood, red cedar and larch (Siberian and Canadian), oak, and chestnut. They are perfect for exterior use because they have tannins that give them good resistance to rot and decay. Larch, oak, and chestnut (all hardwoods) have a higher density than softwood and are resistant to moisture, termites, and decaying organisms. This makes them extra durable even while in the outdoors.

Their golden reddish colors make them very attractive as claddings. To protect the wood from turning greyish, paint or stain it. On the downside, you may need to recoat timber every 3 to 5 years, and timber is also highly flammable! However, you can treat the timber with flame-retardants, but it'll lose its "innocence."

External cladding timber comes in many styles and shapes –shingles, board & batten clapboards, boards, half-logs, etc.). Timber is fairly easy to install and adds visual effects (e.g., horizontal boards elongate your structure, whereas vertical ones make it look taller). Natural timber color is preferred, but you can customize it to your personal preferences.

Lap and smart siding

If you want a modern look but don't want your container to have that glossy steel look, try smart or lap siding. This siding uses engineered wood coated to add durability.

Combination

You can also choose to combine all the finishes to create a unique look for your container home.

TIP 1: You can apply spray foam before adding your finish for maximum insulation. This is particularly useful if you live in a cold area.

TIP 2: Go for eco-friendly finishes because apart from being great for our planet, they also won't endanger your well-being.

Let's now look at some floor selections for your container home.

But, before flooring your container, make sure all the electrical wiring and plumbing fixtures are complete to avoid having to poke holes on your newly installed floor.

Chapter 9: Put in the Floor

Shipping container floors play a big role in increasing the durability and longevity of shipping containers homes. There are many flooring options out there, but some are better than others for homes. Here are five shipping container floor options you can consider.

1: Original Plywood or Bamboo Flooring

Costs around 2.29 per sq. ft



Manufacturers of shipping containers install plywood flooring, but this floor has a huge problem. It attracts ants and other pests. Therefore, it's treated with crude pesticides that can cause health problems, especially for children and the elderly.

Replace the flooring that comes preinstalled with your shipping container to avoid these chemicals and pesticides. You can choose to add a thin layer of plywood or bamboo to the manufacturer's flooring. Or, cover the floor with

a non-breathable underlay and then put your new flooring over the underlay. Apply an epoxy coating on the original plywood floor for a cheaper option. We'll check on epoxy paint coatings later.

Another option is to remove the original flooring altogether and replace it with other alternative flooring options. Although it may be time-consuming and costly, doing this can give you the peace of knowing that you have gotten rid of the pesticide hazard.

2: Imitation Wood Vinyl Planks



Installing imitation wood vinyl planks on your container floor make it stylish and professional. Although synthetic, they look like wood flooring. They are perfect for living spaces and make your home comfy and homey space. Vinyl comes in three shades: light, medium, and a dark finish.

No matter which shade you choose, they are easy to install on the container's original floor. Moreover, Vinyl is low maintenance, long-lasting, water-resistant, and cost-effective.

Nowadays, vinyl comes in smaller planks that have tiny grooves on each side for clipping the plank on each other easily. The way these planks are installed allows them to be easily replaced if one is damaged. You just need to unclip, pull out the damaged plank, and replace it with a new one.

TIP: Install a [rubber underlayment](#) underneath the vinyl to help with soundproofing your floor.

NOTE: Clean your vinyl with a dry mop or vacuum, hot water, and a vinyl floor cleaner. But, be careful as too much water can pluck out vinyl planks due to expansion.

3: Commercial Carpet Tile



Commercial carpet tiles are cost-effective (costs just 37 cents per sq. ft.), durable, plus resistant to wear and tear. Tiles come in various colors, shapes, and sizes. If one or two carpet tiles get damaged or have tough stains, you only need to replace the specific tiles. They also come in planks too.

4: Epoxy Coating



The epoxy coating acts as a protective seal and can be added to any of the above flooring options. An epoxy coating makes your floor anti-slip and gives it a nice finish.

Designed originally for industrial uses, the epoxy coating becomes incredibly hard, waterproof, and resistant to wear and abrasions, corrosion, damage, and stains. Instead of the non-breathable underlay, use an epoxy coating to seal off the original container flooring to keep the pesticides at bay.

NOTE: Epoxy coating and epoxy paint are two different things. You need epoxy coating. The epoxy coating is a mixture of resin and hardener. When dried, this coating seals the harmful chemicals below the surface so that you don't inhale them.

5: Coin Vinyl



Coin vinyl flooring is low cost, durable, water-resistant, and easy to mop and clean. Additionally, its surface is resistant to oil, acid, dirt, and many more stains. It's good for bathrooms and high traffic areas like living rooms. All you have to do is roll it over your container's original plywood flooring.

You might have seen it on dance floors. Coin vinyl style like vinyl flooring comes in a custom fit design for easy installation and maintenance.

It gets its name from the coin-sized raised circles beneath it that give the floor grip, traction, and slip resistance. Coin Vinyl is best used in garages because it's highly resistant to any wear and tear caused by cars driving over it.

However, on the downside, the coin vinyl has few options for colors. Be prepared to choose black, tan, silver, gray, or perhaps sandstone.

6: Aluminum Or Steel Flooring



Another extremely easy-to-maintain flooring alternative is aluminum or steel flooring. The reefer containers usually have this type of flooring that gives it a very 'cold' look. They are also odorless, durable, Scratch-resistant, 100% recyclable, and eco-friendlier than tropical woods.

Your home is livable at this point, but you need to beautify it for aesthetic purposes.

Chapter 10: Do The Final Touches

When designing your new container home, remember two things; every new idea should improve your home's visually, functionally, or both. Sometimes, this would mean installing smart devices such as thermostats, a smart lock, a Roomba vacuum robot cleaner, and so on. However, while such things are obvious and easy to think of, there are things you can easily forget.

With this consideration in mind, let's look at a few final touches on your new container home that can do wonders for your house.

- Childproofing plugs and switches
- Don't forget the floors
- Get a fence
- Landscaping
- Think about pests

Childproofing plugs and switches

Think about the smallest members of your family. We all know (especially us parents) just how risky power sockets can get. That's why you need to address the issue right away.

One of your top priorities should be a solution that can blend into the surroundings. This way, you increase the general safety of your children (which is paramount) and maintain the look of your home. Check out these [child-proofing ideas](#).

Don't forget the floors

Now that your home is done and looking good, it's now time to beautify your floor. You've already picked the best vinyl, tiles, wood, or laminate flooring, but to make it look even better, consider buying one or two area rugs for both indoor and outdoor spaces. A suitable rug adds a whole new aspect to your home; just make sure to go for the size, pattern, and texture that best fits your home. Such additional details are a great way to add final touches to your brand-new home.

Get A Fence With A Gate

Some of us love fences, and some hate them, but one thing for sure is that they bring more benefits to the table. First, they bar unwanted trespassers keeping your property somewhat safer, and stop the entrance of larger animals and pests. Moreover, a fence adds to your home's visuals and gives your property a major boost in value. However, consider your material cost and design when fencing.

Landscaping

Every artistic person understands the role of the background in the beauty of a painting. Considering this, for your home to be the most dazzling ever, dedicate some of your time and resources to landscaping. Flawlessly mowed lawns bestow your home with a unique impression, but if you hate the idea of mowing now and then, go for the artificial grass. Otherwise, a shrub and a flowerbed certainly won't hurt your efforts.

Think about pests

Earlier on, we talked about fencing to keep pests away, but this only works for those animals that can't fly or jump. When it comes to birds, you need a silent bird deterrent.

As for squirrels, cut out branches surrounding your home that help them jump over your fence. As for insects and bugs, well, you should be extra crafty because you don't want to poison your soil with insecticides.

Plant natural pest repellants like herbs like fennel, bay leaves, and chives, or make your own insecticide.

Conclusion

Building a container home on your own is a journey worth taking. Just make sure you have chosen the right design and the shipping container best suited for it. Factor in the cost of everything you do to avoid ‘white elephants.’

Ensure you consult with professionals where necessary.

PS: I’d like your feedback. If you are happy with this book, please leave a review on Amazon.

Please leave a review for this book on Amazon by visiting the page below:

<https://amzn.to/2VMR5qr>

SHIPPING CONTAINER HOMES MADE EASY

Step By Step Guide On How To Build Your First Shipping Container
Home From Scratch As A Complete Beginner

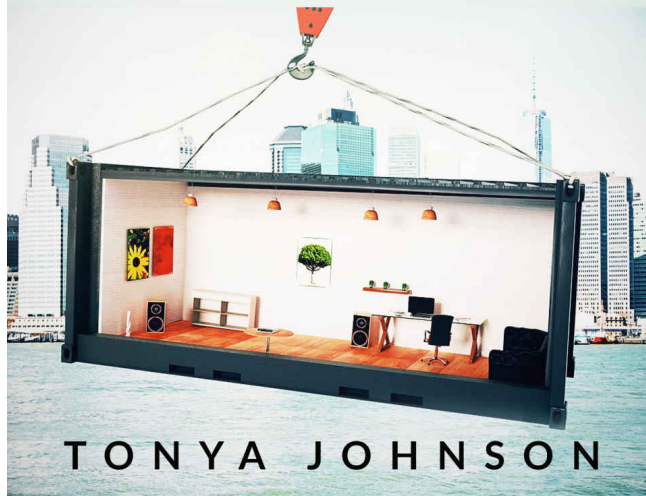

TONYA JOHNSON