

THEODORE L. BERGMAN | ADRIENNE S. LAVINE

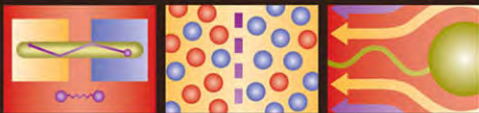

FRANK P. INCROPERA | DAVID P. DEWITT

FUNDAMENTALS OF  
**HEAT** and **MASS** TRANSFER

SEVENTH EDITION

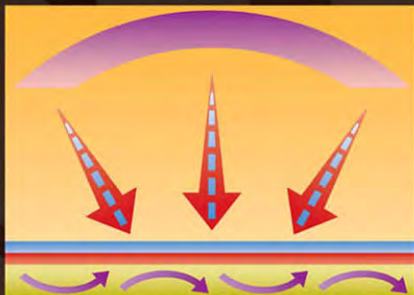

**INSTRUCTOR'S SOLUTIONS MANUAL**

## PROBLEM 1.1

**KNOWN:** Thermal conductivity, thickness and temperature difference across a sheet of rigid extruded insulation.

**FIND:** (a) The heat flux through a 2 m × 2 m sheet of the insulation, and (b) The heat rate through the sheet.

**SCHEMATIC:**

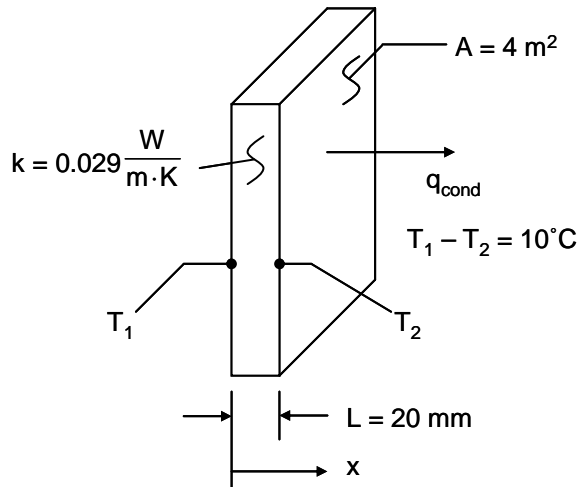

**ASSUMPTIONS:** (1) One-dimensional conduction in the x-direction, (2) Steady-state conditions, (3) Constant properties.

**ANALYSIS:** From Equation 1.2 the heat flux is

$$q_x'' = -k \frac{dT}{dx} = k \frac{T_1 - T_2}{L}$$

Solving,

$$q_x'' = 0.029 \frac{\text{W}}{\text{m} \cdot \text{K}} \times \frac{10 \text{ K}}{0.02 \text{ m}}$$

$$q_x'' = 14.5 \frac{\text{W}}{\text{m}^2} \quad <$$

The heat rate is

$$q_x = q_x'' \cdot A = 14.5 \frac{\text{W}}{\text{m}^2} \times 4 \text{ m}^2 = 58 \text{ W} \quad <$$

**COMMENTS:** (1) Be sure to keep in mind the important distinction between the heat flux ( $\text{W}/\text{m}^2$ ) and the heat rate ( $\text{W}$ ). (2) The direction of heat flow is from hot to cold. (3) Note that a temperature *difference* may be expressed in kelvins or degrees Celsius.

## PROBLEM 1.2

**KNOWN:** Thickness and thermal conductivity of a wall. Heat flux applied to one face and temperatures of both surfaces.

**FIND:** Whether steady-state conditions exist.

**SCHEMATIC:**

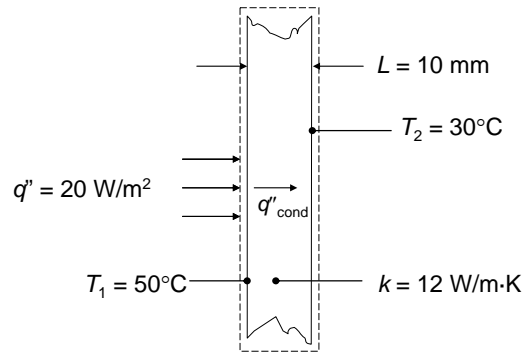

**ASSUMPTIONS:** (1) One-dimensional conduction, (2) Constant properties, (3) No internal energy generation.

**ANALYSIS:** Under steady-state conditions an energy balance on the control volume shown is

$$q''_{\text{in}} = q''_{\text{out}} = q''_{\text{cond}} = k(T_1 - T_2)/L = 12 \text{ W/m}\cdot\text{K}(50^\circ\text{C} - 30^\circ\text{C})/0.01 \text{ m} = 24,000 \text{ W/m}^2$$

Since the heat flux in at the left face is only  $20 \text{ W/m}^2$ , the conditions are not steady state. <

**COMMENTS:** If the same heat flux is maintained until steady-state conditions are reached, the steady-state temperature difference across the wall will be

$$\Delta T = q''L/k = 20 \text{ W/m}^2 \times 0.01 \text{ m}/12 \text{ W/m}\cdot\text{K} = 0.0167 \text{ K}$$

which is much smaller than the specified temperature difference of  $20^\circ\text{C}$ .

### PROBLEM 1.3

**KNOWN:** Inner surface temperature and thermal conductivity of a concrete wall.

**FIND:** Heat loss by conduction through the wall as a function of outer surface temperatures ranging from  $-15$  to  $38^\circ\text{C}$ .

**SCHEMATIC:**

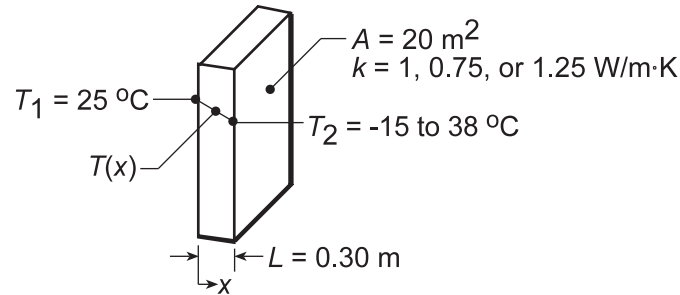

**ASSUMPTIONS:** (1) One-dimensional conduction in the  $x$ -direction, (2) Steady-state conditions, (3) Constant properties.

**ANALYSIS:** From Fourier's law, if  $q_x''$  and  $k$  are each constant it is evident that the gradient,  $dT/dx = -q_x''/k$ , is a constant, and hence the temperature distribution is linear. The heat flux must be constant under one-dimensional, steady-state conditions; and  $k$  is approximately constant if it depends only weakly on temperature. The heat flux and heat rate when the outside wall temperature is  $T_2 = -15^\circ\text{C}$  are

$$q_x'' = -k \frac{dT}{dx} = k \frac{T_1 - T_2}{L} = 1 \text{ W/m} \cdot \text{K} \frac{25^\circ\text{C} - (-15^\circ\text{C})}{0.30 \text{ m}} = 133.3 \text{ W/m}^2. \quad (1)$$

$$q_x = q_x'' \times A = 133.3 \text{ W/m}^2 \times 20 \text{ m}^2 = 2667 \text{ W}. \quad (2) <$$

Combining Eqs. (1) and (2), the heat rate  $q_x$  can be determined for the range of outer surface temperature,  $-15 \leq T_2 \leq 38^\circ\text{C}$ , with different wall thermal conductivities,  $k$ .

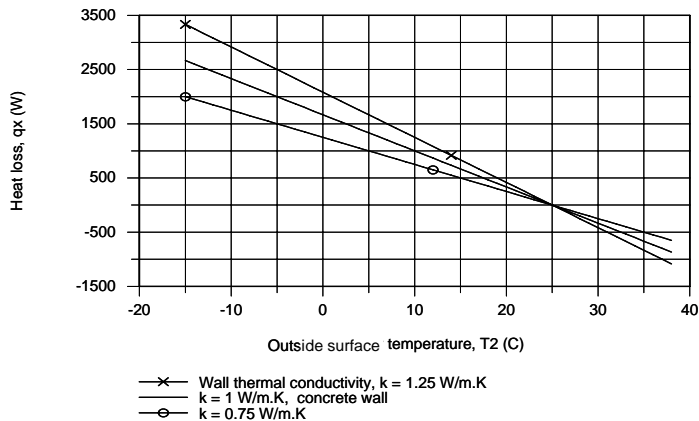

For the concrete wall,  $k = 1 \text{ W/m}\cdot\text{K}$ , the heat loss varies linearly from  $+2667 \text{ W}$  to  $-867 \text{ W}$  and is zero when the inside and outer surface temperatures are the same. The magnitude of the heat rate increases with increasing thermal conductivity.

**COMMENTS:** Without steady-state conditions and constant  $k$ , the temperature distribution in a plane wall would not be linear.

## PROBLEM 1.4

**KNOWN:** Dimensions, thermal conductivity and surface temperatures of a concrete slab. Efficiency of gas furnace and cost of natural gas.

**FIND:** Daily cost of heat loss.

**SCHEMATIC:**

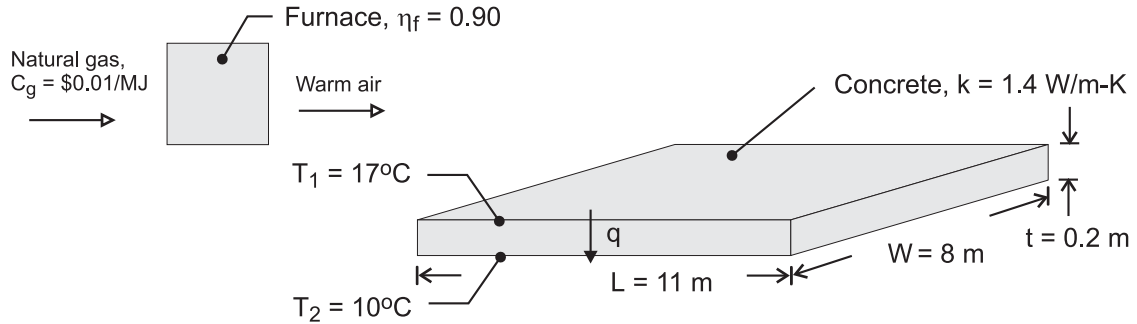

**ASSUMPTIONS:** (1) Steady state, (2) One-dimensional conduction, (3) Constant properties.

**ANALYSIS:** The rate of heat loss by conduction through the slab is

$$q = k(LW) \frac{T_1 - T_2}{t} = 1.4 \text{ W/m} \cdot \text{K} (11 \text{ m} \times 8 \text{ m}) \frac{7^\circ\text{C}}{0.20 \text{ m}} = 4312 \text{ W} \quad <$$

The daily cost of natural gas that must be combusted to compensate for the heat loss is

$$C_d = \frac{q C_g}{\eta_f} (\Delta t) = \frac{4312 \text{ W} \times \$0.02 / \text{MJ}}{0.9 \times 10^6 \text{ J/MJ}} (24 \text{ h/d} \times 3600 \text{ s/h}) = \$8.28 / \text{d} \quad <$$

**COMMENTS:** The loss could be reduced by installing a floor covering with a layer of insulation between it and the concrete.

## PROBLEM 1.5

**KNOWN:** Thermal conductivity and thickness of a wall. Heat flux through wall. Steady-state conditions.

**FIND:** Value of temperature gradient in K/m and in °C/m.

**SCHEMATIC:**

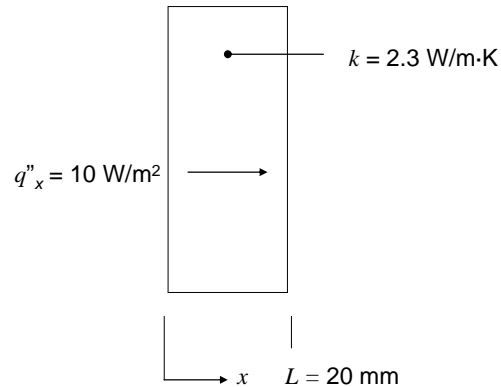

**ASSUMPTIONS:** (1) One-dimensional conduction, (2) Constant properties.

**ANALYSIS:** Under steady-state conditions,

$$\frac{dT}{dx} = -\frac{q''_x}{k} = -\frac{10 \text{ W/m}^2}{2.3 \text{ W/m}\cdot\text{K}} = -4.35 \text{ K/m} = -4.35 \text{ }^\circ\text{C/m} \quad <$$

Since the K units here represent a temperature *difference*, and since the temperature difference is the same in K and °C units, the temperature gradient value is the same in either units.

**COMMENTS:** A negative value of temperature gradient means that temperature is decreasing with increasing  $x$ , corresponding to a positive heat flux in the  $x$ -direction.

### PROBLEM 1.6

**KNOWN:** Heat flux and surface temperatures associated with a wood slab of prescribed thickness.

**FIND:** Thermal conductivity,  $k$ , of the wood.

**SCHEMATIC:**

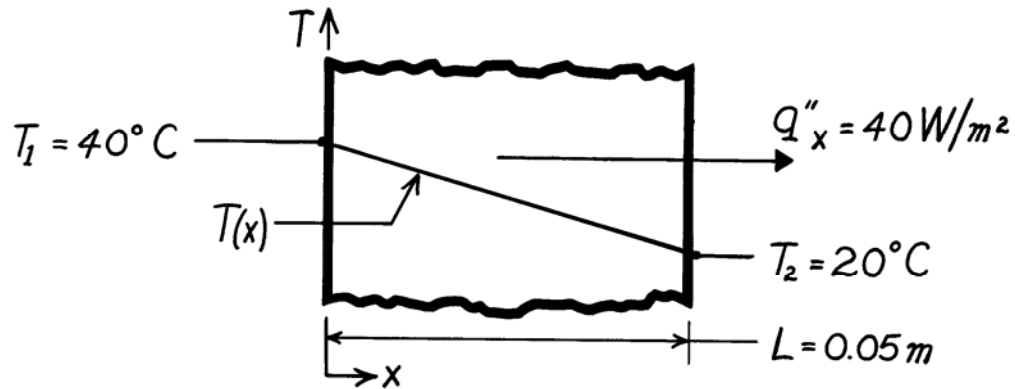

**ASSUMPTIONS:** (1) One-dimensional conduction in the  $x$ -direction, (2) Steady-state conditions, (3) Constant properties.

**ANALYSIS:** Subject to the foregoing assumptions, the thermal conductivity may be determined from Fourier's law, Eq. 1.2. Rearranging,

$$k = q''_x \frac{L}{T_1 - T_2} = 40 \frac{\text{W}}{\text{m}^2} \frac{0.05 \text{ m}}{(40 - 20)^\circ \text{C}}$$

$$k = 0.10 \text{ W/m} \cdot \text{K}$$

<

**COMMENTS:** Note that the  $^\circ\text{C}$  or  $\text{K}$  temperature units may be used interchangeably when evaluating a temperature difference.

### PROBLEM 1.7

**KNOWN:** Inner and outer surface temperatures of a glass window of prescribed dimensions.

**FIND:** Heat loss through window.

**SCHEMATIC:**

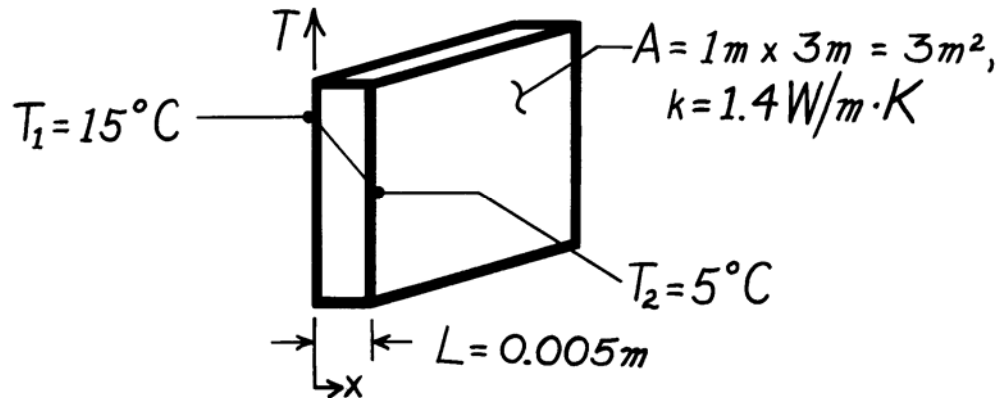

**ASSUMPTIONS:** (1) One-dimensional conduction in the  $x$ -direction, (2) Steady-state conditions, (3) Constant properties.

**ANALYSIS:** Subject to the foregoing conditions the heat flux may be computed from Fourier's law, Eq. 1.2.

$$q_x'' = k \frac{T_1 - T_2}{L}$$
$$q_x'' = 1.4 \frac{\text{W}}{\text{m}\cdot\text{K}} \frac{(15-5)^\circ\text{C}}{0.005\text{m}}$$
$$q_x'' = 2800 \text{ W/m}^2.$$

Since the heat flux is uniform over the surface, the heat loss (rate) is

$$q = q_x'' \times A$$
$$q = 2800 \text{ W/m}^2 \times 3\text{m}^2$$
$$q = 8400 \text{ W.}$$

**COMMENTS:** A linear temperature distribution exists in the glass for the prescribed conditions.



## PROBLEM 1.8

**KNOWN:** Net power output, average compressor and turbine temperatures, shaft dimensions and thermal conductivity.

**FIND:** (a) Comparison of the conduction rate through the shaft to the predicted net power output of the device, (b) Plot of the ratio of the shaft conduction heat rate to the anticipated net power output of the device over the range  $0.005 \text{ m} \leq L \leq 1 \text{ m}$  and feasibility of a  $L = 0.005 \text{ m}$  device.

**SCHEMATIC:**

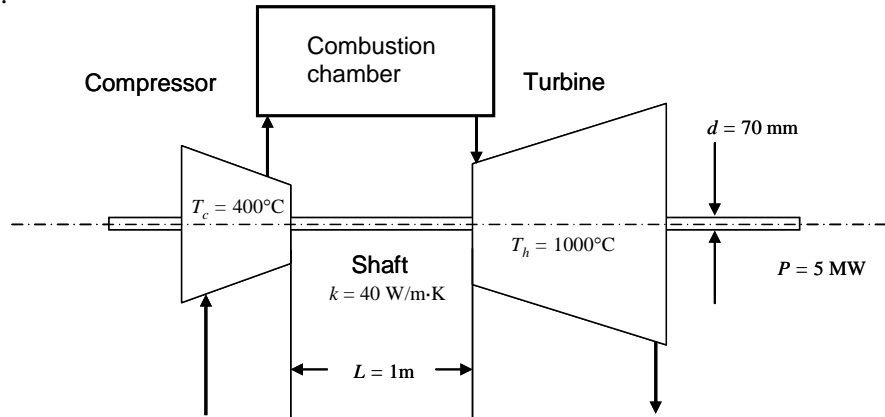

**ASSUMPTIONS:** (1) Steady-state conditions, (2) Constant properties, (3) Net power output is proportional to the volume of the gas turbine.

**PROPERTIES:** Shaft (given):  $k = 40 \text{ W/m}\cdot\text{K}$ .

**ANALYSIS:** (a) The conduction through the shaft may be evaluated using Fourier's law, yielding

$$q = q'' A_c = \frac{k(T_h - T_c)}{L} (\pi d^2 / 4) = \frac{40 \text{ W/m}\cdot\text{K} (1000 - 400)^\circ\text{C}}{1 \text{ m}} (\pi (70 \times 10^{-3} \text{ m})^2 / 4) = 92.4 \text{ W}$$

The ratio of the conduction heat rate to the net power output is

$$r = \frac{q}{P} = \frac{92.4 \text{ W}}{5 \times 10^6 \text{ W}} = 18.5 \times 10^{-6} \quad <$$

(b) The volume of the turbine is proportional to  $L^3$ . Designating  $L_a = 1 \text{ m}$ ,  $d_a = 70 \text{ mm}$  and  $P_a$  as the shaft length, shaft diameter, and net power output, respectively, in part (a),

$$d = d_a \times (L/L_a); P = P_a \times (L/L_a)^3$$

and the ratio of the conduction heat rate to the net power output is

$$\begin{aligned} r &= \frac{q'' A_c}{P} = \frac{\frac{k(T_h - T_c)}{L} (\pi d^2 / 4)}{P} = \frac{\frac{k(T_h - T_c)}{L} (\pi (d_a L / L_a)^2 / 4)}{P_a (L/L_a)^3} = \frac{\frac{k(T_h - T_c) \pi}{4} d_a^2 L_a / P_a}{L^2} \\ &= \frac{\frac{40 \text{ W/m}\cdot\text{K} (1000 - 400)^\circ\text{C} \pi}{4} (70 \times 10^{-3} \text{ m})^2 \times 1 \text{ m} / 5 \times 10^6 \text{ W}}{L^2} = \frac{18.5 \times 10^{-6} \text{ m}^2}{L^2} \end{aligned}$$

Continued...

### PROBLEM 1.8 (Cont.)

The ratio of the shaft conduction to net power is shown below. At  $L = 0.005 \text{ m} = 5 \text{ mm}$ , the shaft conduction to net power output ratio is 0.74. The concept of the very small turbine is not feasible since it will be unlikely that the large temperature difference between the compressor and turbine can be maintained. <

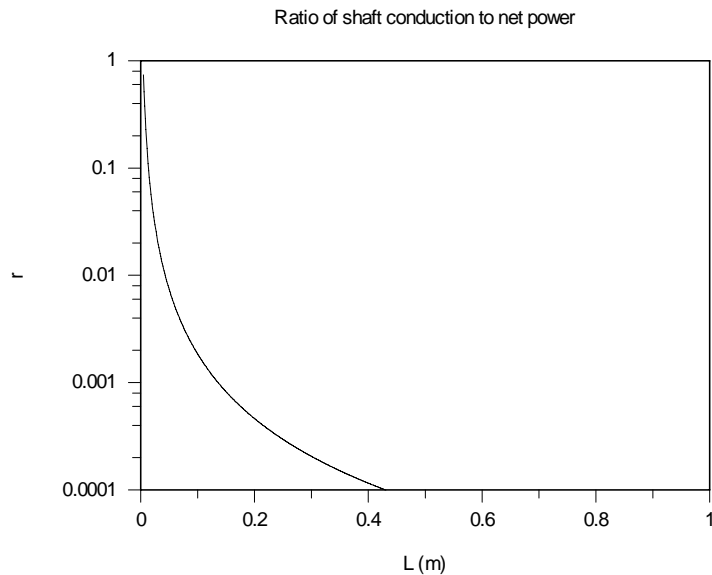

**COMMENTS:** (1) The thermodynamics analysis does not account for heat transfer effects and is therefore meaningful only when heat transfer can be safely ignored, as is the case for the shaft in part (a). (2) Successful miniaturization of thermal devices is often hindered by heat transfer effects that must be overcome with innovative design.

## PROBLEM 1.9

**KNOWN:** Width, height, thickness and thermal conductivity of a single pane window and the air space of a double pane window. Representative winter surface temperatures of single pane and air space.

**FIND:** Heat loss through single and double pane windows.

**SCHEMATIC:**

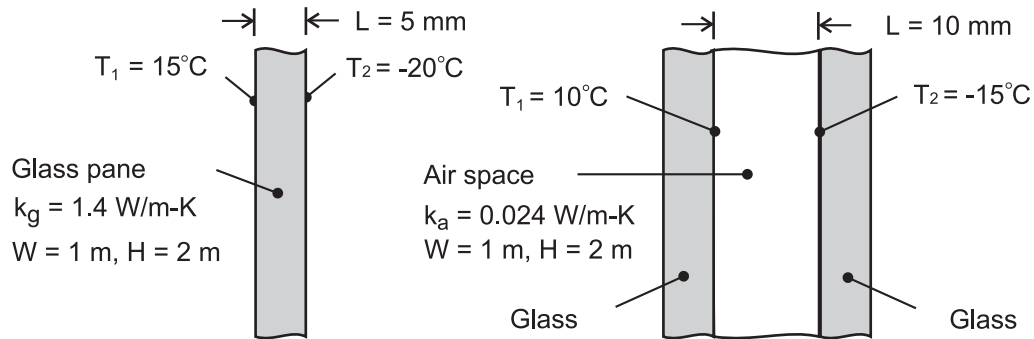

**ASSUMPTIONS:** (1) One-dimensional conduction through glass or air, (2) Steady-state conditions, (3) Enclosed air of double pane window is stagnant (negligible buoyancy induced motion).

**ANALYSIS:** From Fourier's law, the heat losses are

$$\text{Single Pane: } q_g = k_g A \frac{T_1 - T_2}{L} = 1.4 \text{ W/m} \cdot \text{K} \left( 2 \text{ m}^2 \right) \frac{35^\circ\text{C}}{0.005 \text{ m}} = 19,600 \text{ W} \quad <$$

$$\text{Double Pane: } q_a = k_a A \frac{T_1 - T_2}{L} = 0.024 \left( 2 \text{ m}^2 \right) \frac{25^\circ\text{C}}{0.010 \text{ m}} = 120 \text{ W} \quad <$$

**COMMENTS:** Losses associated with a single pane are unacceptable and would remain excessive, even if the thickness of the glass were doubled to match that of the air space. The principal advantage of the double pane construction resides with the low thermal conductivity of air (~ 60 times smaller than that of glass). For a fixed ambient outside air temperature, use of the double pane construction would also increase the surface temperature of the glass exposed to the room (inside) air.

### PROBLEM 1.10

**KNOWN:** Dimensions of freezer compartment. Inner and outer surface temperatures.

**FIND:** Thickness of styrofoam insulation needed to maintain heat load below prescribed value.

**SCHEMATIC:**

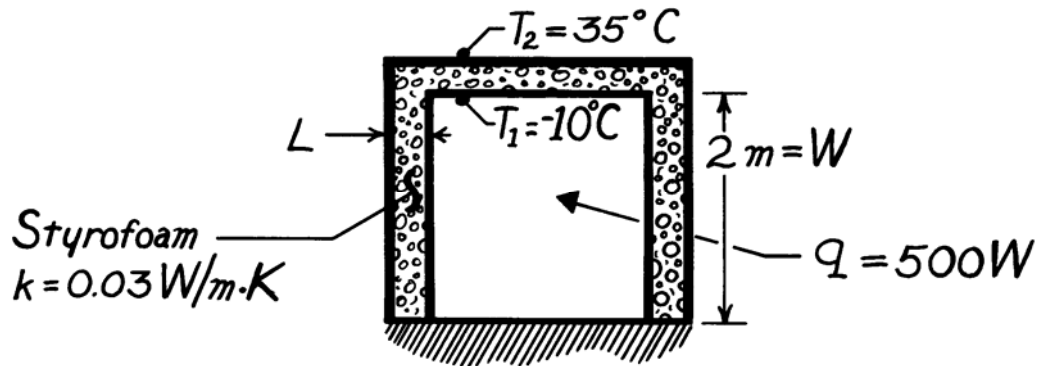

**ASSUMPTIONS:** (1) Perfectly insulated bottom, (2) One-dimensional conduction through 5 walls of area  $A = 4m^2$ , (3) Steady-state conditions, (4) Constant properties.

**ANALYSIS:** Using Fourier's law, Eq. 1.2, the heat rate is

$$q = q'' \cdot A = k \frac{\Delta T}{L} A_{\text{total}}$$

Solving for  $L$  and recognizing that  $A_{\text{total}} = 5 \times W^2$ , find

$$L = \frac{5 k \Delta T W^2}{q}$$

$$L = \frac{5 \times 0.03 \text{ W/m}\cdot\text{K} [35 - (-10)]^\circ\text{C} (4\text{m}^2)}{500 \text{ W}}$$

$$L = 0.054\text{m} = 54\text{mm.}$$

<

**COMMENTS:** The corners will cause local departures from one-dimensional conduction and a slightly larger heat loss.

## PROBLEM 1.11

**KNOWN:** Heat flux at one face and air temperature and convection coefficient at other face of plane wall. Temperature of surface exposed to convection.

**FIND:** If steady-state conditions exist. If not, whether the temperature is increasing or decreasing.

**SCHEMATIC:**

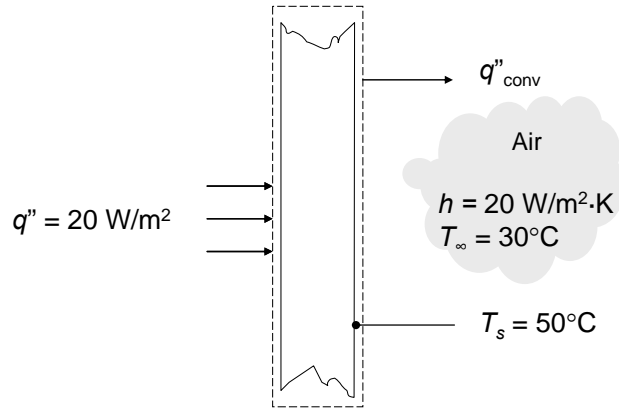

**ASSUMPTIONS:** (1) One-dimensional conduction, (2) No internal energy generation.

**ANALYSIS:** Conservation of energy for a control volume around the wall gives

$$\frac{dE_{st}}{dt} = \dot{E}_{in} - \dot{E}_{out} + \dot{E}_g$$

$$\begin{aligned}\frac{dE_{st}}{dt} &= q''_{in}A - hA(T_s - T_{\infty}) = [q''_{in} - h(T_s - T_{\infty})]A \\ &= [20 \text{ W/m}^2 - 20 \text{ W/m}^2 \cdot \text{K}(50^{\circ}\text{C} - 30^{\circ}\text{C})]A = -380 \text{ W/m}^2A\end{aligned}$$

Since  $dE_{st}/dt \neq 0$ , the system is not at steady-state. <

Since  $dE_{st}/dt < 0$ , the stored energy is decreasing, therefore the wall temperature is decreasing. <

**COMMENTS:** When the surface temperature of the face exposed to convection cools to  $31^{\circ}\text{C}$ ,  $q_{in} = q_{out}$  and  $dE_{st}/dt = 0$  and the wall will have reached steady-state conditions.

### PROBLEM 1.12

**KNOWN:** Dimensions and thermal conductivity of food/beverage container. Inner and outer surface temperatures.

**FIND:** Heat flux through container wall and total heat load.

**SCHEMATIC:**

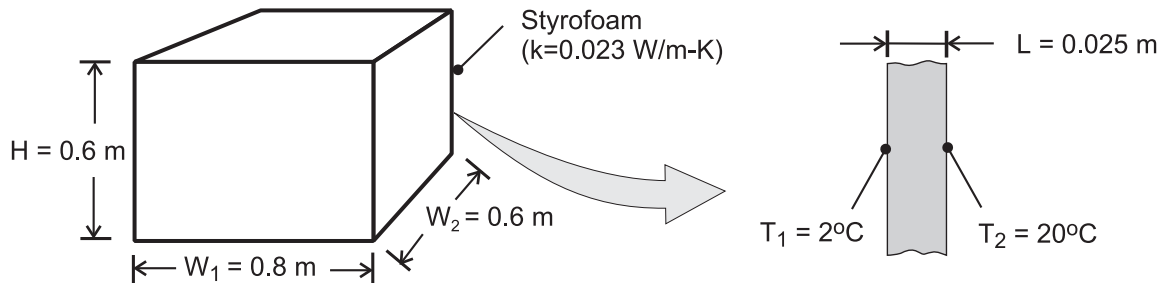

**ASSUMPTIONS:** (1) Steady-state conditions, (2) Negligible heat transfer through bottom wall, (3) Uniform surface temperatures and one-dimensional conduction through remaining walls.

**ANALYSIS:** From Fourier's law, Eq. 1.2, the heat flux is

$$q'' = k \frac{T_2 - T_1}{L} = \frac{0.023 \text{ W/m} \cdot \text{K} (20 - 2)^\circ \text{C}}{0.025 \text{ m}} = 16.6 \text{ W/m}^2 \quad <$$

Since the flux is uniform over each of the five walls through which heat is transferred, the heat load is

$$q = q'' \times A_{\text{total}} = q'' [H(2W_1 + 2W_2) + W_1 \times W_2]$$
$$q = 16.6 \text{ W/m}^2 [0.6\text{m}(1.6\text{m} + 1.2\text{m}) + (0.8\text{m} \times 0.6\text{m})] = 35.9 \text{ W} \quad <$$

**COMMENTS:** The corners and edges of the container create local departures from one-dimensional conduction, which increase the heat load. However, for  $H, W_1, W_2 \gg L$ , the effect is negligible.

### PROBLEM 1.13

**KNOWN:** Masonry wall of known thermal conductivity has a heat rate which is 80% of that through a composite wall of prescribed thermal conductivity and thickness.

**FIND:** Thickness of masonry wall.

**SCHEMATIC:**

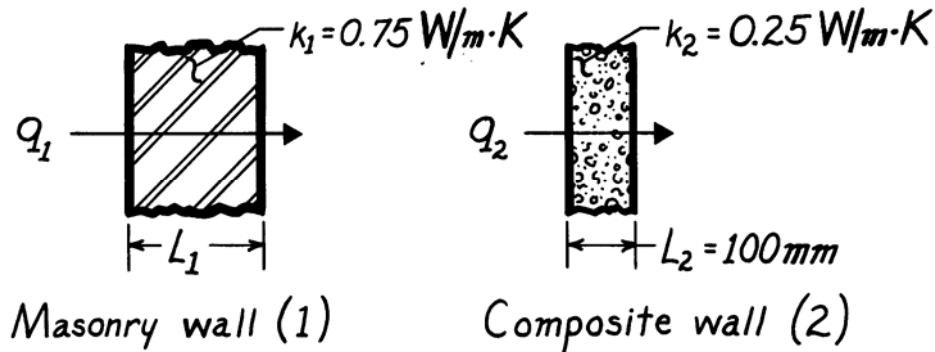

**ASSUMPTIONS:** (1) Both walls subjected to same surface temperatures, (2) One-dimensional conduction, (3) Steady-state conditions, (4) Constant properties.

**ANALYSIS:** For steady-state conditions, the conduction heat flux through a one-dimensional wall follows from Fourier's law, Eq. 1.2,

$$q'' = k \frac{\Delta T}{L}$$

where  $\Delta T$  represents the difference in surface temperatures. Since  $\Delta T$  is the same for both walls, it follows that

$$L_1 = L_2 \frac{k_1}{k_2} \cdot \frac{q_2''}{q_1''}$$

With the heat fluxes related as

$$q_1'' = 0.8 q_2''$$

$$L_1 = 100 \text{ mm} \frac{0.75 \text{ W/m}\cdot\text{K}}{0.25 \text{ W/m}\cdot\text{K}} \times \frac{1}{0.8} = 375 \text{ mm.} \quad <$$

**COMMENTS:** Not knowing the temperature difference across the walls, we cannot find the value of the heat rate.

### PROBLEM 1.14

**KNOWN:** Expression for variable thermal conductivity of a wall. Constant heat flux. Temperature at  $x = 0$ .

**FIND:** Expression for temperature gradient and temperature distribution.

**SCHEMATIC:**

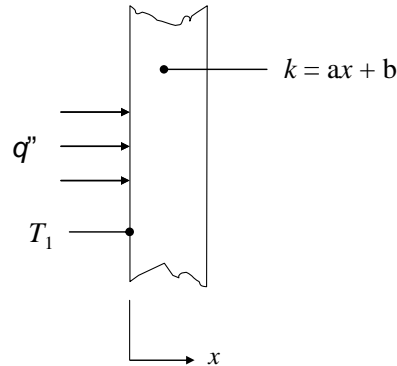

**ASSUMPTIONS:** (1) One-dimensional conduction.

**ANALYSIS:** The heat flux is given by Fourier's law, and is known to be constant, therefore

$$q_x'' = -k \frac{dT}{dx} = \text{constant}$$

Solving for the temperature gradient and substituting the expression for  $k$  yields

$$\frac{dT}{dx} = -\frac{q_x''}{k} = -\frac{q_x''}{ax + b} \quad <$$

This expression can be integrated to find the temperature distribution, as follows:

$$\int \frac{dT}{dx} dx = -\int \frac{q_x''}{ax + b} dx$$

Since  $q_x'' = \text{constant}$ , we can integrate the right hand side to find

$$T = -\frac{q_x''}{a} \ln(ax + b) + c$$

where  $c$  is a constant of integration. Applying the known condition that  $T = T_1$  at  $x = 0$ , we can solve for  $c$ .

Continued...



**PROBLEM 1.14 (Cont.)**

$$\begin{aligned}T(x = 0) &= T_1 \\ -\frac{q_x''}{a} \ln b + c &= T_1 \\ c &= T_1 + \frac{q_x''}{a} \ln b\end{aligned}$$

Therefore, the temperature distribution is given by

$$\begin{aligned}T &= -\frac{q_x''}{a} \ln(ax + b) + T_1 + \frac{q_x''}{a} \ln b &< \\ &= T_1 + \frac{q_x''}{a} \ln \frac{b}{ax + b} &<\end{aligned}$$

**COMMENTS:** Temperature distributions are not linear in many situations, such as when the thermal conductivity varies spatially or is a function of temperature. Non-linear temperature distributions may also evolve if internal energy generation occurs or non-steady conditions exist.

### PROBLEM 1.15

**KNOWN:** Thickness, diameter and inner surface temperature of bottom of pan used to boil water. Rate of heat transfer to the pan.

**FIND:** Outer surface temperature of pan for an aluminum and a copper bottom.

**SCHEMATIC:**

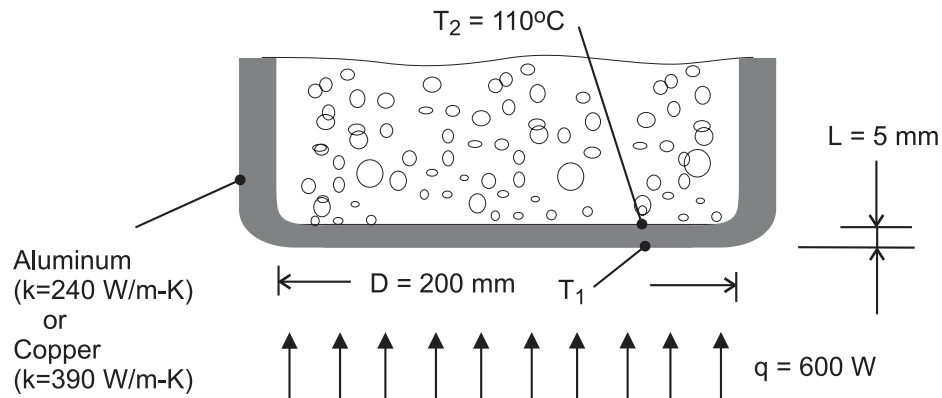

**ASSUMPTIONS:** (1) One-dimensional, steady-state conduction through bottom of pan.

**ANALYSIS:** From Fourier's law, the rate of heat transfer by conduction through the bottom of the pan is

$$q = kA \frac{T_1 - T_2}{L}$$

Hence,

$$T_1 = T_2 + \frac{qL}{kA}$$

where  $A = \pi D^2 / 4 = \pi (0.2\text{ m})^2 / 4 = 0.0314\text{ m}^2$ .

$$\text{Aluminum: } T_1 = 110^\circ\text{C} + \frac{600\text{ W}(0.005\text{ m})}{240\text{ W/m}\cdot\text{K}(0.0314\text{ m}^2)} = 110.40^\circ\text{C} \quad <$$

$$\text{Copper: } T_1 = 110^\circ\text{C} + \frac{600\text{ W}(0.005\text{ m})}{390\text{ W/m}\cdot\text{K}(0.0314\text{ m}^2)} = 110.24^\circ\text{C} \quad <$$

**COMMENTS:** Although the temperature drop across the bottom is slightly larger for aluminum (due to its smaller thermal conductivity), it is sufficiently small to be negligible for both materials. To a good approximation, the bottom may be considered *isothermal* at  $T \approx 110^\circ\text{C}$ , which is a desirable feature of pots and pans.

### PROBLEM 1.16

**KNOWN:** Dimensions and thermal conductivity of a chip. Power dissipated on one surface.

**FIND:** Temperature drop across the chip.

**SCHEMATIC:**

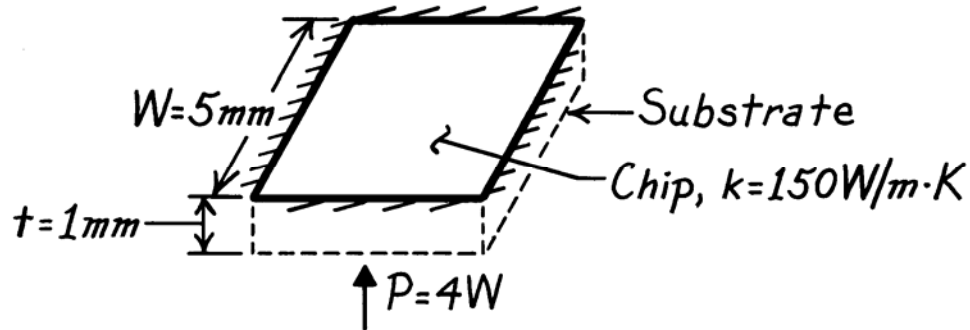

**ASSUMPTIONS:** (1) Steady-state conditions, (2) Constant properties, (3) Uniform heat dissipation, (4) Negligible heat loss from back and sides, (5) One-dimensional conduction in chip.

**ANALYSIS:** All of the electrical power dissipated at the back surface of the chip is transferred by conduction through the chip. Hence, from Fourier's law,

$$P = q = kA \frac{\Delta T}{t}$$

or

$$\Delta T = \frac{t \cdot P}{kW^2} = \frac{0.001\text{ m} \times 4\text{ W}}{150\text{ W/m}\cdot\text{K} (0.005\text{ m})^2}$$

$$\Delta T = 1.1^\circ\text{ C.}$$

<

**COMMENTS:** For fixed  $P$ , the temperature drop across the chip decreases with increasing  $k$  and  $W$ , as well as with decreasing  $t$ .

## PROBLEM 1.17

**KNOWN:** Heat flux and convection heat transfer coefficient for boiling water. Saturation temperature and convection heat transfer coefficient for boiling dielectric fluid.

**FIND:** Upper surface temperature of plate when water is boiling. Whether plan for minimizing surface temperature by using dielectric fluid will work.

**SCHEMATIC:**

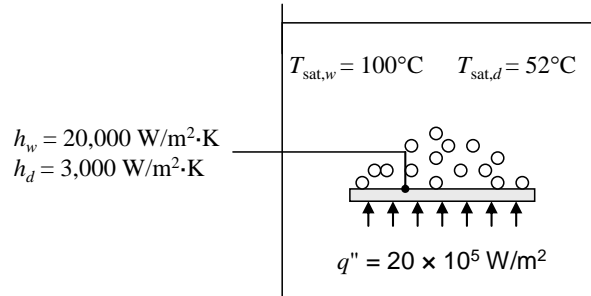

**ASSUMPTIONS:** Steady-state conditions.

**PROPERTIES:**  $T_{\text{sat},w} = 100^\circ\text{C}$  at  $p = 1$  atm.

**ANALYSIS:** According to the problem statement, Newton's law of cooling can be expressed for a boiling process as

$$q'' = h(T_s - T_{\text{sat}})$$

Thus,

$$T_s = T_{\text{sat}} + q''/h$$

When the fluid is water,

$$T_{s,w} = T_{\text{sat},w} + q''/h_w = 100^\circ\text{C} + \frac{20 \times 10^5 \text{ W/m}^2}{20 \times 10^3 \text{ W/m}^2 \cdot \text{K}} = 200^\circ\text{C}$$

When the dielectric fluid is used,

$$T_{s,d} = T_{\text{sat},d} + q''/h_d = 52^\circ\text{C} + \frac{20 \times 10^5 \text{ W/m}^2}{3 \times 10^3 \text{ W/m}^2 \cdot \text{K}} = 719^\circ\text{C}$$

Thus, the technician's proposed approach will not reduce the surface temperature. <

**COMMENTS:** (1) Even though the dielectric fluid has a lower saturation temperature, this is more than offset by the lower heat transfer coefficient associated with the dielectric fluid. The surface temperature with the dielectric coolant exceeds the melting temperature of many metals such as aluminum and aluminum alloys. (2) Dielectric fluids are, however, employed in applications such as *immersion cooling* of electronic components, where an electrically-conducting fluid such as water could not be used.

### PROBLEM 1.18

**KNOWN:** Hand experiencing convection heat transfer with moving air and water.

**FIND:** Determine which condition feels colder. Contrast these results with a heat loss of  $30 \text{ W/m}^2$  under normal room conditions.

**SCHEMATIC:**

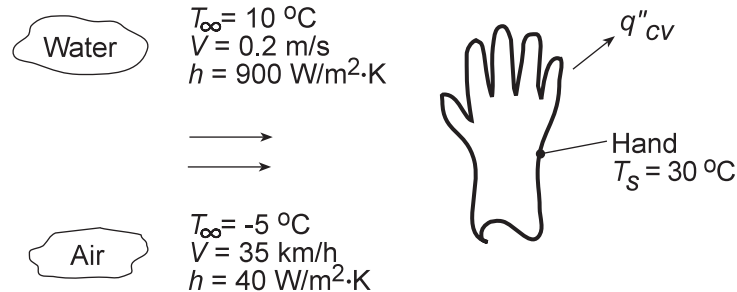

**ASSUMPTIONS:** (1) Temperature is uniform over the hand's surface, (2) Convection coefficient is uniform over the hand, and (3) Negligible radiation exchange between hand and surroundings in the case of air flow.

**ANALYSIS:** The hand will feel colder for the condition which results in the larger heat loss. The heat loss can be determined from Newton's law of cooling, Eq. 1.3a, written as

$$q'' = h(T_s - T_{\infty})$$

For the air stream:

$$q''_{\text{air}} = 40 \text{ W/m}^2 \cdot \text{K} [30 - (-5)] \text{ K} = 1,400 \text{ W/m}^2 <$$

For the water stream:

$$q''_{\text{water}} = 900 \text{ W/m}^2 \cdot \text{K} (30 - 10) \text{ K} = 18,000 \text{ W/m}^2 <$$

**COMMENTS:** The heat loss for the hand in the water stream is an order of magnitude larger than when in the air stream for the given temperature and convection coefficient conditions. In contrast, the heat loss in a normal room environment is only  $30 \text{ W/m}^2$  which is a factor of 400 times less than the loss in the air stream. In the room environment, the hand would feel comfortable; in the air and water streams, as you probably know from experience, the hand would feel uncomfortably cold since the heat loss is excessively high.

## PROBLEM 1.19

**KNOWN:** Power required to maintain the surface temperature of a long, 25-mm diameter cylinder with an imbedded electrical heater for different air velocities.

**FIND:** (a) Determine the convection coefficient for each of the air velocity conditions and display the results graphically, and (b) Assuming that the convection coefficient depends upon air velocity as  $h = CV^n$ , determine the parameters  $C$  and  $n$ .

**SCHEMATIC:**

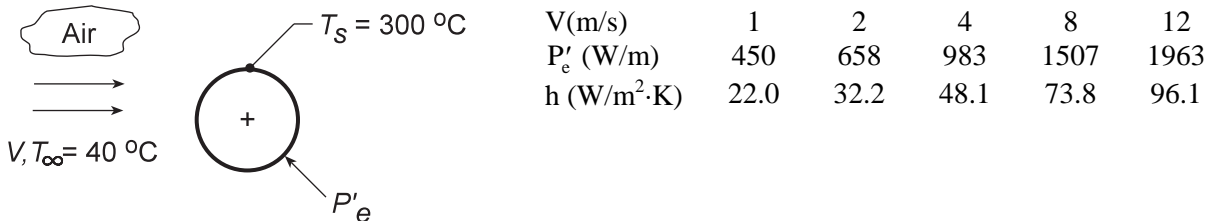

**ASSUMPTIONS:** (1) Temperature is uniform over the cylinder surface, (2) Negligible radiation exchange between the cylinder surface and the surroundings, (3) Steady-state conditions.

**ANALYSIS:** (a) From an overall energy balance on the cylinder, the power dissipated by the electrical heater is transferred by convection to the air stream. Using Newton's law of cooling on a per unit length basis,

$$P'_e = h(\pi D)(T_s - T_\infty)$$

where  $P'_e$  is the electrical power dissipated per unit length of the cylinder. For the  $V = 1$  m/s condition, using the data from the table above, find

$$h = 450 \text{ W/m} / \pi \times 0.025 \text{ m} (300 - 40)^\circ \text{C} = 22.0 \text{ W/m}^2 \cdot \text{K}$$

Repeating the calculations, find the convection coefficients for the remaining conditions which are tabulated above and plotted below. Note that  $h$  is not linear with respect to the air velocity.

(b) To determine the  $(C, n)$  parameters, we plotted  $h$  vs.  $V$  on log-log coordinates. Choosing  $C = 22.12$  W/m<sup>2</sup>·K(s/m) <sup>$n$</sup> , assuring a match at  $V = 1$ , we can readily find the exponent  $n$  from the slope of the  $h$  vs.  $V$  curve. From the trials with  $n = 0.8, 0.6$  and  $0.5$ , we recognize that  $n = 0.6$  is a reasonable choice.

Hence,  $C = 22.12$  and  $n = 0.6$ .

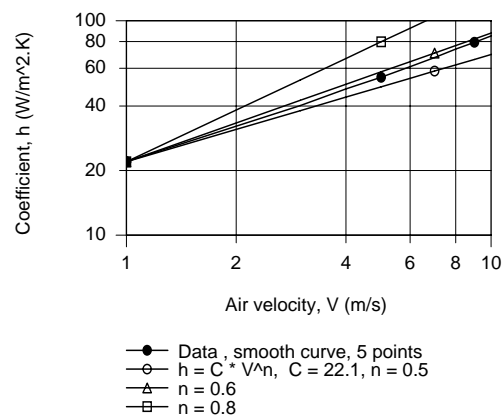
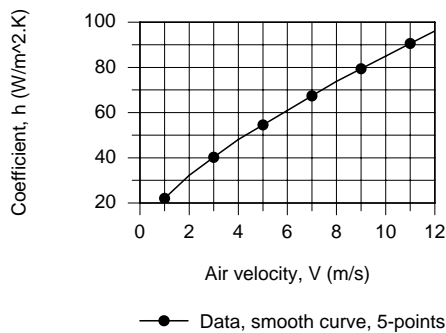

**COMMENTS:** Radiation may not be negligible, depending on surface emissivity.

## PROBLEM 1.20

**KNOWN:** Inner and outer surface temperatures of a wall. Inner and outer air temperatures and convection heat transfer coefficients.

**FIND:** Heat flux from inner air to wall. Heat flux from wall to outer air. Heat flux from wall to inner air. Whether wall is under steady-state conditions.

**SCHEMATIC:**

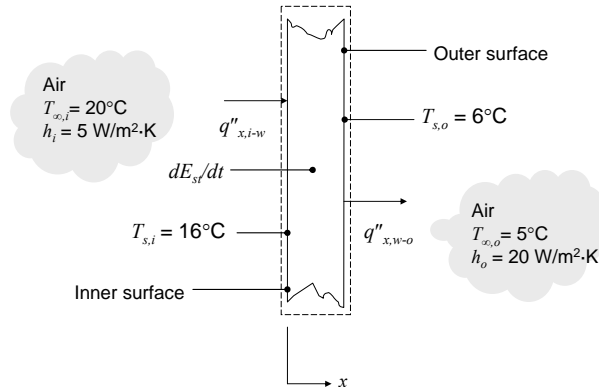

**ASSUMPTIONS:** (1) Negligible radiation, (2) No internal energy generation.

**ANALYSIS:** The heat fluxes can be calculated using Newton's law of cooling. Convection from the inner air to the wall occurs in the positive x-direction:

$$q''_{x,i-w} = h_i(T_{\infty,i} - T_{s,i}) = 5 \text{ W/m}^2 \cdot \text{K} \times (20^\circ\text{C} - 16^\circ\text{C}) = 20 \text{ W/m}^2 \quad <$$

Convection from the wall to the outer air also occurs in the positive x-direction:

$$q''_{x,w-o} = h_o(T_{s,o} - T_{\infty,o}) = 20 \text{ W/m}^2 \cdot \text{K} \times (6^\circ\text{C} - 5^\circ\text{C}) = 20 \text{ W/m}^2 \quad <$$

From the wall to the inner air:

$$q''_{w-i} = h_i(T_{s,i} - T_{\infty,i}) = 5 \text{ W/m}^2 \cdot \text{K} \times (16^\circ\text{C} - 20^\circ\text{C}) = -20 \text{ W/m}^2 \quad <$$

An energy balance on the wall gives

$$\frac{dE_{st}}{dt} = \dot{E}_{in} - \dot{E}_{out} = A(q''_{x,i-w} - q''_{x,w-o}) = 0$$

Since  $dE_{st}/dt = 0$ , the wall *could be* at steady-state and the *spatially-averaged* wall temperature is not changing. However, it is possible that stored energy is increasing in one part of the wall and decreasing in another, therefore we cannot tell if the wall is at steady-state or not. If we found

$dE_{st}/dt \neq 0$ , we would know the wall was not at steady-state. <

**COMMENTS:** The heat flux from the wall to the inner air is equal and opposite to the heat flux from the inner air to the wall.

### PROBLEM 1.21

**KNOWN:** Long, 30mm-diameter cylinder with embedded electrical heater; power required to maintain a specified surface temperature for water and air flows.

**FIND:** Convection coefficients for the water and air flow convection processes,  $h_w$  and  $h_a$ , respectively.

**SCHEMATIC:**

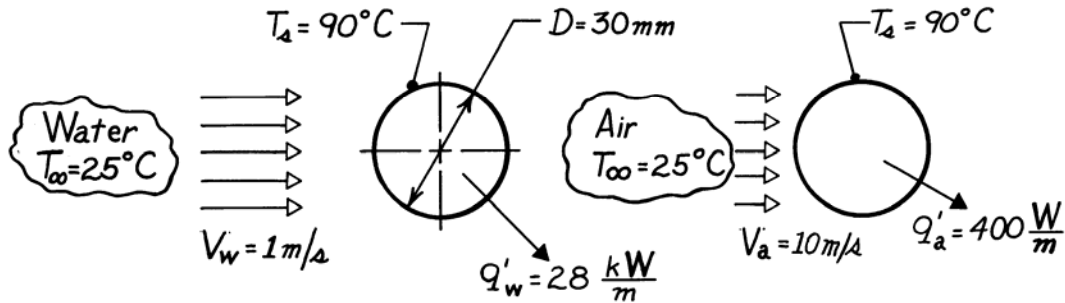

**ASSUMPTIONS:** (1) Flow is cross-wise over cylinder which is very long in the direction normal to flow.

**ANALYSIS:** The convection heat rate from the cylinder per unit length of the cylinder has the form

$$q' = h(\pi D) (T_s - T_\infty)$$

and solving for the heat transfer convection coefficient, find

$$h = \frac{q'}{\pi D (T_s - T_\infty)}$$

Substituting numerical values for the water and air situations:

$$\text{Water} \quad h_w = \frac{28 \times 10^3 \text{ W/m}}{\pi \times 0.030\text{ m} (90-25)^\circ \text{ C}} = 4,570 \text{ W/m}^2 \cdot \text{K} <$$

$$\text{Air} \quad h_a = \frac{400 \text{ W/m}}{\pi \times 0.030\text{ m} (90-25)^\circ \text{ C}} = 65 \text{ W/m}^2 \cdot \text{K}. <$$

**COMMENTS:** Note that the air velocity is 10 times that of the water flow, yet

$$h_w \approx 70 \times h_a.$$

These values for the convection coefficient are typical for forced convection heat transfer with liquids and gases. See Table 1.1.



## PROBLEM 1.22

**KNOWN:** Hot vertical plate suspended in cool, still air. Change in plate temperature with time at the instant when the plate temperature is 225°C.

**FIND:** Convection heat transfer coefficient for this condition.

**SCHEMATIC:**

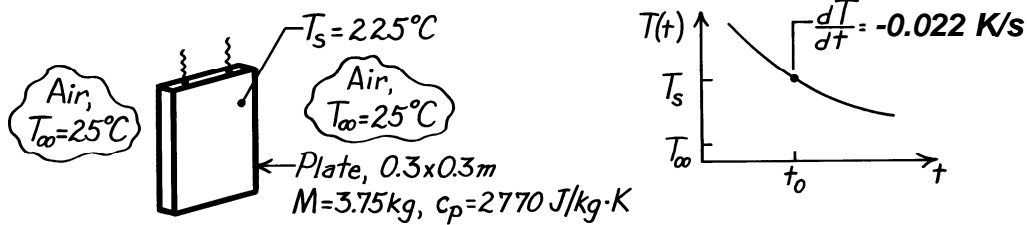

**ASSUMPTIONS:** (1) Plate is isothermal, (2) Negligible radiation exchange with surroundings, (3) Negligible heat lost through suspension wires.

**ANALYSIS:** As shown in the cooling curve above, the plate temperature decreases with time. The condition of interest is for time  $t_0$ . For a control surface about the plate, the conservation of energy requirement is

$$\dot{E}_{\text{in}} - \dot{E}_{\text{out}} = \dot{E}_{\text{st}}$$

$$-2hA_s(T_s - T_\infty) = Mc_p \frac{dT}{dt}$$

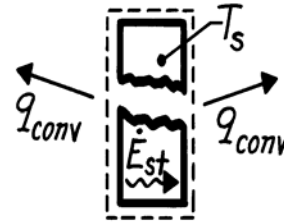

where  $A_s$  is the surface area of one side of the plate. Solving for  $h$ , find

$$h = \frac{Mc_p}{2A_s(T_s - T_\infty)} \left( \frac{-dT}{dt} \right)$$

$$h = \frac{3.75 \text{ kg} \times 2770 \text{ J/kg}\cdot\text{K}}{2 \times (0.3 \times 0.3) \text{ m}^2} \times 0.022 \text{ K/s} = 6.3 \text{ W/m}^2 \cdot \text{K}$$

<

**COMMENTS:** (1) Assuming the plate is very highly polished with emissivity of 0.08, determine whether radiation exchange with the surroundings at 25°C is negligible compared to convection.

(2) We will later consider the criterion for determining whether the isothermal plate assumption is reasonable. If the thermal conductivity of the present plate were high (such as aluminum or copper), the criterion would be satisfied.

### PROBLEM 1.23

**KNOWN:** Width, input power and efficiency of a transmission. Temperature and convection coefficient associated with air flow over the casing.

**FIND:** Surface temperature of casing.

**SCHEMATIC:**

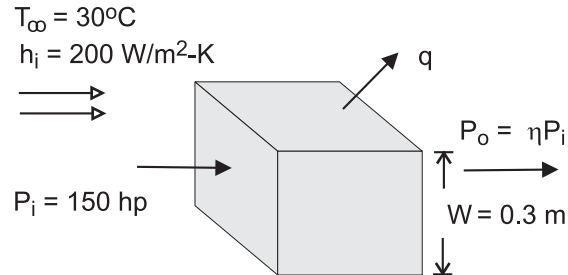

**ASSUMPTIONS:** (1) Steady state, (2) Uniform convection coefficient and surface temperature, (3) Negligible radiation.

**ANALYSIS:** From Newton's law of cooling,

$$q = hA_s (T_s - T_\infty) = 6hW^2 (T_s - T_\infty)$$

where the output power is  $\eta P_i$  and the heat rate is

$$q = P_i - P_o = P_i (1 - \eta) = 150 \text{ hp} \times 746 \text{ W / hp} \times 0.07 = 7833 \text{ W}$$

Hence,

$$T_s = T_\infty + \frac{q}{6hW^2} = 30^\circ\text{C} + \frac{7833 \text{ W}}{6 \times 200 \text{ W/m}^2 \cdot \text{K} \times (0.3 \text{ m})^2} = 102.5^\circ\text{C} \quad <$$

**COMMENTS:** There will, in fact, be considerable variability of the local convection coefficient over the transmission case and the prescribed value represents an average over the surface.

### PROBLEM 1.24

**KNOWN:** Dimensions of a cartridge heater. Heater power. Convection coefficients in air and water at a prescribed temperature.

**FIND:** Heater surface temperatures in water and air.

**SCHEMATIC:**

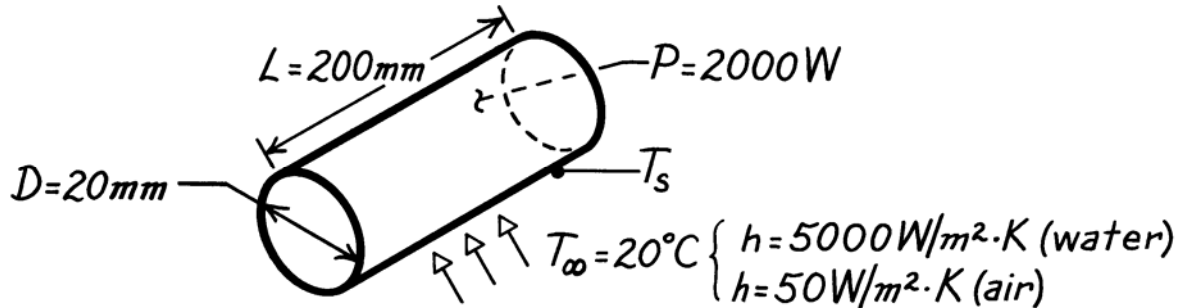

**ASSUMPTIONS:** (1) Steady-state conditions, (2) All of the electrical power is transferred to the fluid by convection, (3) Negligible heat transfer from ends.

**ANALYSIS:** With  $P = q_{\text{conv}}$ , Newton's law of cooling yields

$$P = hA(T_s - T_\infty) = h\pi DL(T_s - T_\infty)$$
$$T_s = T_\infty + \frac{P}{h\pi DL}$$

In water,

$$T_s = 20^\circ \text{C} + \frac{2000 \text{ W}}{5000 \text{ W/m}^2 \cdot \text{K} \times \pi \times 0.02 \text{ m} \times 0.200 \text{ m}}$$

$$T_s = 20^\circ \text{C} + 31.8^\circ \text{C} = 51.8^\circ \text{C}.$$

<

In air,

$$T_s = 20^\circ \text{C} + \frac{2000 \text{ W}}{50 \text{ W/m}^2 \cdot \text{K} \times \pi \times 0.02 \text{ m} \times 0.200 \text{ m}}$$

$$T_s = 20^\circ \text{C} + 3183^\circ \text{C} = 3203^\circ \text{C}.$$

<

**COMMENTS:** (1) Air is much less effective than water as a heat transfer fluid. Hence, the cartridge temperature is much higher in air, so high, in fact, that the cartridge would melt. (2) In air, the high cartridge temperature would render radiation significant.

### PROBLEM 1.25

**KNOWN:** Length, diameter and calibration of a hot wire anemometer. Temperature of air stream. Current, voltage drop and surface temperature of wire for a particular application.

**FIND:** Air velocity

**SCHEMATIC:**

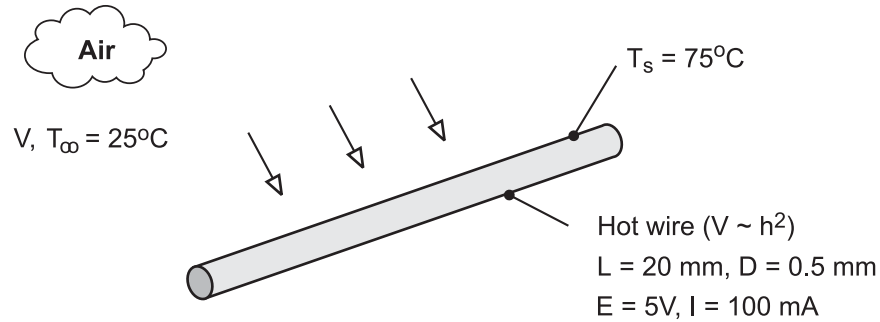

**ASSUMPTIONS:** (1) Steady-state conditions, (2) Negligible heat transfer from the wire by natural convection or radiation.

**ANALYSIS:** If all of the electric energy is transferred by convection to the air, the following equality must be satisfied

$$P_{\text{elec}} = EI = hA(T_s - T_{\infty})$$

where  $A = \pi DL = \pi(0.0005\text{m} \times 0.02\text{m}) = 3.14 \times 10^{-5} \text{ m}^2$ .

Hence,

$$h = \frac{EI}{A(T_s - T_{\infty})} = \frac{5\text{V} \times 0.1\text{A}}{3.14 \times 10^{-5} \text{ m}^2 (50^{\circ}\text{C})} = 318 \text{ W/m}^2 \cdot \text{K}$$

$$V = 6.25 \times 10^{-5} h^2 = 6.25 \times 10^{-5} (318 \text{ W/m}^2 \cdot \text{K})^2 = 6.3 \text{ m/s} \quad <$$

**COMMENTS:** The convection coefficient is sufficiently large to render buoyancy (natural convection) and radiation effects negligible.

### PROBLEM 1.26

**KNOWN:** Chip width and maximum allowable temperature. Coolant conditions.

**FIND:** Maximum allowable chip power for air and liquid coolants.

**SCHEMATIC:**

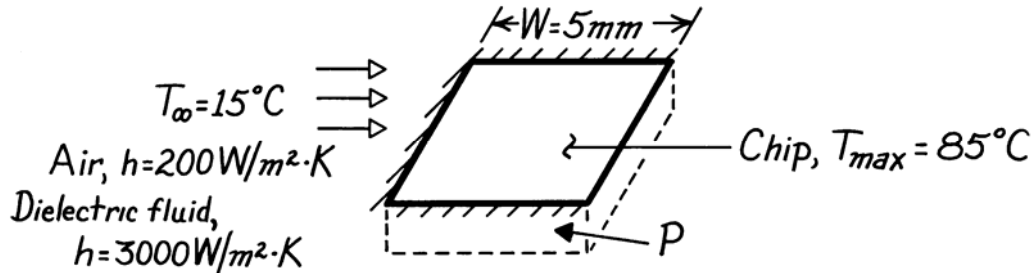

**ASSUMPTIONS:** (1) Steady-state conditions, (2) Negligible heat transfer from sides and bottom, (3) Chip is at a uniform temperature (isothermal), (4) Negligible heat transfer by radiation in air.

**ANALYSIS:** All of the electrical power dissipated in the chip is transferred by convection to the coolant. Hence,

$$P = q$$

and from Newton's law of cooling,

$$P = hA(T - T_{\infty}) = hW^2(T - T_{\infty}).$$

In *air*,

$$P_{\max} = 200 \text{ W/m}^2 \cdot \text{K} (0.005 \text{ m})^2 (85 - 15) ^\circ \text{C} = 0.35 \text{ W.} \quad <$$

In the *dielectric liquid*

$$P_{\max} = 3000 \text{ W/m}^2 \cdot \text{K} (0.005 \text{ m})^2 (85 - 15) ^\circ \text{C} = 5.25 \text{ W.} \quad <$$

**COMMENTS:** Relative to liquids, air is a poor heat transfer fluid. Hence, in air the chip can dissipate far less energy than in the dielectric liquid.

### PROBLEM 1.27

**KNOWN:** Upper temperature set point,  $T_{\text{set}}$ , of a bimetallic switch and convection heat transfer coefficient between clothes dryer air and exposed surface of switch.

**FIND:** Electrical power for heater to maintain  $T_{\text{set}}$  when air temperature is  $T_{\infty} = 50^{\circ}\text{C}$ .

**SCHEMATIC:**

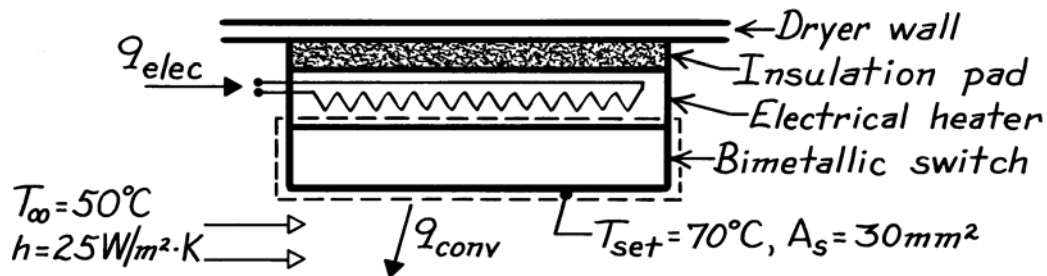

**ASSUMPTIONS:** (1) Steady-state conditions, (2) Electrical heater is perfectly insulated from dryer wall, (3) Heater and switch are isothermal at  $T_{\text{set}}$ , (4) Negligible heat transfer from sides of heater or switch, (5) Switch surface,  $A_s$ , loses heat only by convection.

**ANALYSIS:** Define a control volume around the bimetallic switch which experiences heat input from the heater and convection heat transfer to the dryer air. That is,

$$\begin{aligned} \dot{E}_{\text{in}} - \dot{E}_{\text{out}} &= 0 \\ q_{\text{elec}} - hA_s(T_{\text{set}} - T_{\infty}) &= 0. \end{aligned}$$

The electrical power required is,

$$q_{\text{elec}} = hA_s(T_{\text{set}} - T_{\infty})$$

$$q_{\text{elec}} = 25 \text{ W/m}^2 \cdot \text{K} \times 30 \times 10^{-6} \text{ m}^2 (70 - 50) \text{ K} = 15 \text{ mW}. \quad <$$

**COMMENTS:** (1) This type of controller can achieve variable operating air temperatures with a single set-point, inexpensive, bimetallic-thermostatic switch by adjusting power levels to the heater.

(2) Will the heater power requirement increase or decrease if the insulation pad is other than perfect?

## PROBLEM 1.28

**KNOWN:** Length, diameter, surface temperature and emissivity of steam line. Temperature and convection coefficient associated with ambient air. Efficiency and fuel cost for gas fired furnace.

**FIND:** (a) Rate of heat loss, (b) Annual cost of heat loss.

**SCHEMATIC:**

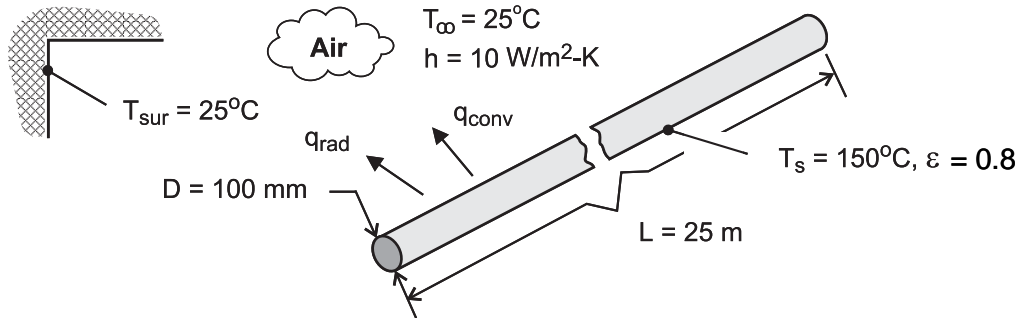

**ASSUMPTIONS:** (1) Steam line operates continuously throughout year, (2) Net radiation transfer is between small surface (steam line) and large enclosure (plant walls).

**ANALYSIS:** (a) From Eqs. (1.3a) and (1.7), the heat loss is

$$q = q_{\text{conv}} + q_{\text{rad}} = A \left[ h(T_s - T_{\infty}) + \varepsilon \sigma (T_s^4 - T_{\text{sur}}^4) \right]$$

where  $A = \pi DL = \pi(0.1\text{m} \times 25\text{m}) = 7.85\text{m}^2$ .

Hence,

$$q = 7.85\text{m}^2 \left[ 10 \text{ W/m}^2 \cdot \text{K} (150 - 25)\text{K} + 0.8 \times 5.67 \times 10^{-8} \text{ W/m}^2 \cdot \text{K}^4 (423^4 - 298^4) \text{K}^4 \right]$$

$$q = 7.85\text{m}^2 (1,250 + 1,095) \text{ W/m}^2 = (9813 + 8592) \text{ W} = 18,405 \text{ W} \quad <$$

(b) The annual energy loss is

$$E = qt = 18,405 \text{ W} \times 3600 \text{ s/h} \times 24\text{h/d} \times 365 \text{ d/y} = 5.80 \times 10^{11} \text{ J}$$

With a furnace energy consumption of  $E_f = E/\eta_f = 6.45 \times 10^{11} \text{ J}$ , the annual cost of the loss is

$$C = C_g E_f = 0.02 \text{ \$/MJ} \times 6.45 \times 10^5 \text{ MJ} = \$12,900 \quad <$$

**COMMENTS:** The heat loss and related costs are unacceptable and should be reduced by insulating the steam line.

## PROBLEM 1.29

**KNOWN:** Air and wall temperatures of a room. Surface temperature, convection coefficient and emissivity of a person in the room.

**FIND:** Basis for difference in comfort level between summer and winter.

**SCHEMATIC:**

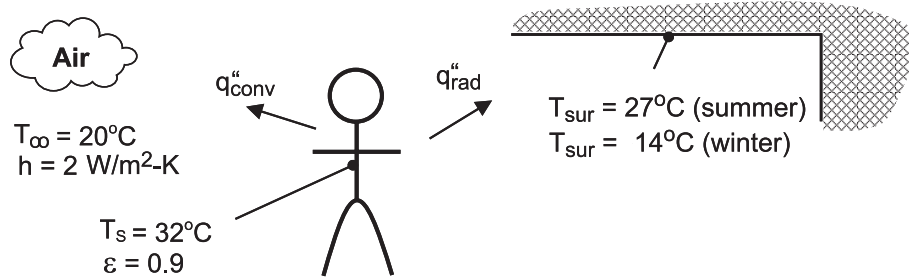

**ASSUMPTIONS:** (1) Person may be approximated as a small object in a large enclosure.

**ANALYSIS:** Thermal comfort is linked to heat loss from the human body, and a *chilled* feeling is associated with excessive heat loss. Because the temperature of the room air is fixed, the different summer and winter comfort levels cannot be attributed to convection heat transfer from the body. In both cases, the heat flux is

$$\text{Summer and Winter: } q_{\text{conv}}'' = h(T_s - T_{\infty}) = 2 \text{ W/m}^2 \cdot \text{K} \times 12 \text{ }^{\circ}\text{C} = 24 \text{ W/m}^2$$

However, the heat flux due to radiation will differ, with values of

$$\text{Summer: } q_{\text{rad}}'' = \varepsilon \sigma (T_s^4 - T_{\text{sur}}^4) = 0.9 \times 5.67 \times 10^{-8} \text{ W/m}^2 \cdot \text{K}^4 (305^4 - 300^4) \text{ K}^4 = 28.3 \text{ W/m}^2$$

$$\text{Winter: } q_{\text{rad}}'' = \varepsilon \sigma (T_s^4 - T_{\text{sur}}^4) = 0.9 \times 5.67 \times 10^{-8} \text{ W/m}^2 \cdot \text{K}^4 (305^4 - 287^4) \text{ K}^4 = 95.4 \text{ W/m}^2$$

There is a significant difference between winter and summer radiation fluxes, and the chilled condition is attributable to the effect of the colder walls on radiation.

**COMMENTS:** For a representative surface area of  $A = 1.5 \text{ m}^2$ , the heat losses are  $q_{\text{conv}} = 36 \text{ W}$ ,  $q_{\text{rad}}(\text{summer}) = 42.5 \text{ W}$  and  $q_{\text{rad}}(\text{winter}) = 143.1 \text{ W}$ . The winter time radiation loss is significant and if maintained over a 24 h period would amount to 2,950 kcal.



### PROBLEM 1.30

**KNOWN:** Diameter and emissivity of spherical interplanetary probe. Power dissipation within probe.

**FIND:** Probe surface temperature.

**SCHEMATIC:**

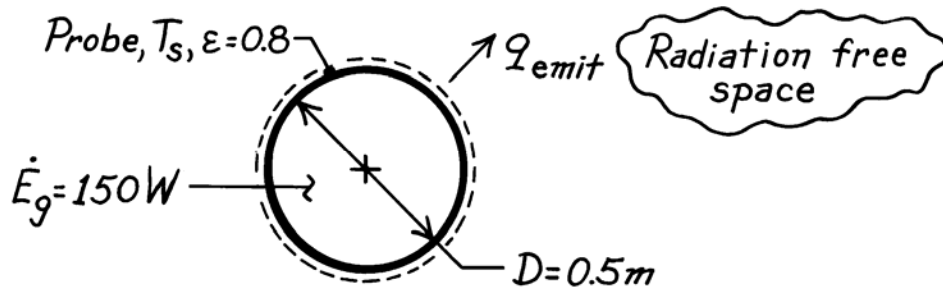

**ASSUMPTIONS:** (1) Steady-state conditions, (2) Negligible radiation incident on the probe.

**ANALYSIS:** Conservation of energy dictates a balance between energy generation within the probe and radiation emission from the probe surface. Hence, at any instant

$$-\dot{E}_{\text{out}} + \dot{E}_g = 0$$

$$\varepsilon A_s \sigma T_s^4 = \dot{E}_g$$

$$T_s = \left( \frac{\dot{E}_g}{\varepsilon \pi D^2 \sigma} \right)^{1/4}$$

$$T_s = \left( \frac{150 \text{ W}}{0.8 \pi (0.5 \text{ m})^2 5.67 \times 10^{-8} \text{ W/m}^2 \cdot \text{K}^4} \right)^{1/4}$$

$$T_s = 254.7 \text{ K.}$$

<

**COMMENTS:** Incident radiation, as, for example, from the sun, would increase the surface temperature.

### PROBLEM 1.31

**KNOWN:** Spherical shaped instrumentation package with prescribed surface emissivity within a large space-simulation chamber having walls at 77 K.

**FIND:** Acceptable power dissipation for operating the package surface temperature in the range  $T_s = 40$  to  $85^\circ\text{C}$ . Show graphically the effect of emissivity variations for 0.2 and 0.3.

**SCHEMATIC:**

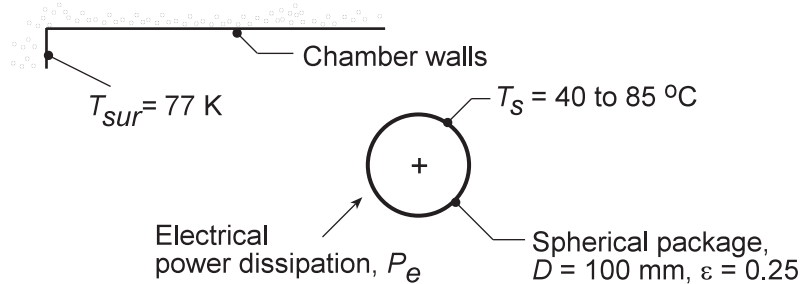

**ASSUMPTIONS:** (1) Uniform surface temperature, (2) Chamber walls are large compared to the spherical package, and (3) Steady-state conditions.

**ANALYSIS:** From an overall energy balance on the package, the internal power dissipation  $P_e$  will be transferred by radiation exchange between the package and the chamber walls. From Eq. 1.7,

$$q_{\text{rad}} = P_e = \epsilon A_s \sigma (T_s^4 - T_{\text{sur}}^4)$$

For the condition when  $T_s = 40^\circ\text{C}$ , with  $A_s = \pi D^2$  the power dissipation will be

$$P_e = 0.25 (\pi \times 0.10^2 \text{ m}^2) \times 5.67 \times 10^{-8} \text{ W/m}^2 \cdot \text{K}^4 \times [(40 + 273)^4 - 77^4] \text{ K}^4 = 4.3 \text{ W} \quad <$$

Repeating this calculation for the range  $40 \leq T_s \leq 85^\circ\text{C}$ , we can obtain the power dissipation as a function of surface temperature for the  $\epsilon = 0.25$  condition. Similarly, with 0.2 or 0.3, the family of curves shown below has been obtained.

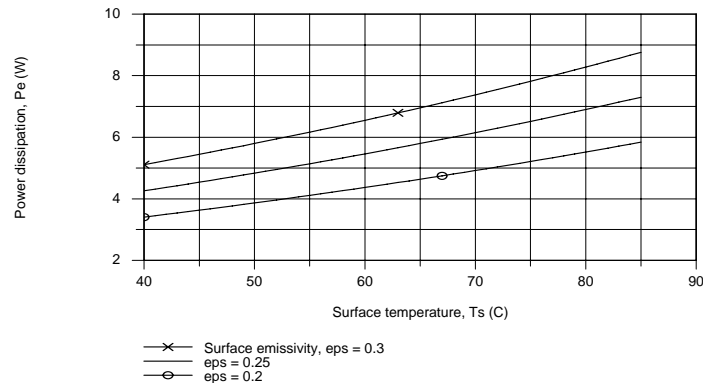

**COMMENTS:** (1) As expected, the internal power dissipation increases with increasing emissivity and surface temperature. Because the radiation rate equation is non-linear with respect to temperature, the power dissipation will likewise not be linear with surface temperature.

(2) What is the maximum power dissipation that is possible if the surface temperature is not to exceed  $85^\circ\text{C}$ ? What kind of a coating should be applied to the instrument package in order to approach this limiting condition?

### PROBLEM 1.32

**KNOWN:** Hot plate suspended in vacuum and surroundings temperature. Mass, specific heat, area and time rate of change of plate temperature.

**FIND:** (a) The emissivity of the plate, and (b) The rate at which radiation is emitted from the plate.

**SCHEMATIC:**

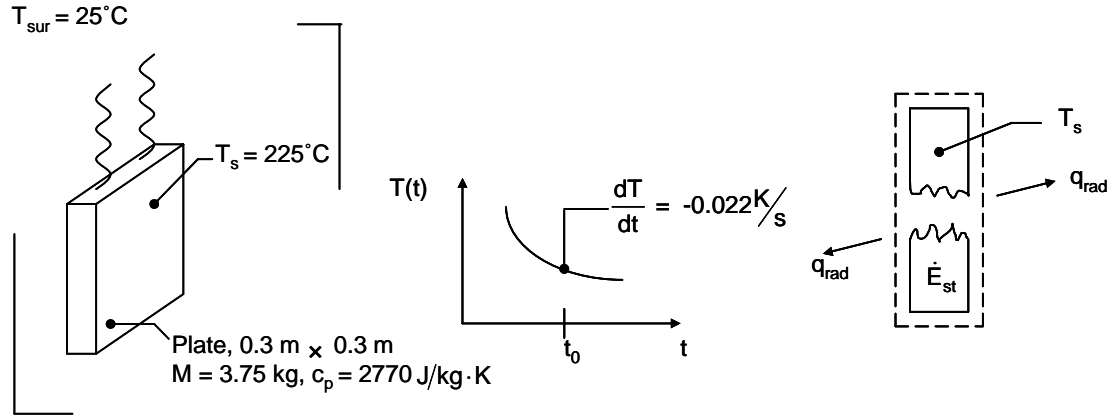

**ASSUMPTIONS:** (1) Plate is isothermal and at uniform temperature, (2) Large surroundings, (3) Negligible heat loss through suspension wires.

**ANALYSIS:** For a control volume about the plate, the conservation of energy requirement is

$$\dot{E}_{\text{in}} - \dot{E}_{\text{out}} = \dot{E}_{\text{st}} \quad (1)$$

$$\text{where } \dot{E}_{\text{st}} = Mc_p \frac{dT}{dt} \quad (2)$$

$$\text{and for large surroundings } \dot{E}_{\text{in}} - \dot{E}_{\text{out}} = A\varepsilon\sigma(T_{\text{sur}}^4 - T_s^4) \quad (3)$$

Combining Eqns. (1) through (3) yields

$$\varepsilon = \frac{Mc_p \frac{dT}{dt}}{A\sigma (T_{\text{sur}}^4 - T_s^4)}$$

Noting that \$T\_{\text{sur}} = 25^\circ\text{C} + 273\text{ K} = 298\text{ K}\$ and \$T\_s = 225^\circ\text{C} + 273\text{ K} = 498\text{ K}\$, we find

$$\varepsilon = \frac{3.75\text{ kg} \times 2770 \frac{\text{J}}{\text{kg}\cdot\text{K}} \times (-0.022 \frac{\text{K}}{\text{s}})}{2 \times 0.3\text{ m} \times 0.3\text{ m} \times 5.67 \times 10^{-8} \frac{\text{W}}{\text{m}^2 \cdot \text{K}^4} (498^4 - 298^4)\text{ K}^4} = 0.42 <$$

The rate at which radiation is emitted from the plate is

$$q_{\text{rad,e}} = \varepsilon A \sigma T_s^4 = 0.42 \times 2 \times 0.3\text{ m} \times 0.3\text{ m} \times 5.67 \times 10^{-8} \frac{\text{W}}{\text{m}^2 \cdot \text{K}^4} \times (498\text{ K})^4 = 264\text{ W} <$$

**COMMENTS:** Note the importance of using kelvins when working with radiation heat transfer.

### PROBLEM 1.33

**KNOWN:** Exact and approximate expressions for the linearized radiation coefficient,  $h_r$  and  $h_{r,a}$ , respectively.

**FIND:** (a) Comparison of the coefficients with  $\varepsilon = 0.05$  and  $0.9$  and surface temperatures which may exceed that of the surroundings ( $T_{sur} = 25^\circ\text{C}$ ) by  $10$  to  $100^\circ\text{C}$ ; also comparison with a free convection coefficient correlation, (b) Plot of the relative error  $(h_r - h_{r,a})/h_r$  as a function of the furnace temperature associated with a workpiece at  $T_s = 25^\circ\text{C}$  having  $\varepsilon = 0.05, 0.2$  or  $0.9$ .

**ASSUMPTIONS:** (1) Furnace walls are large compared to the workpiece and (2) Steady-state conditions.

**ANALYSIS:** (a) The linearized radiation coefficient, Eq. 1.9, follows from the radiation exchange rate equation,

$$h_r = \varepsilon\sigma(T_s + T_{sur})(T_s^2 + T_{sur}^2)$$

If  $T_s \approx T_{sur}$ , the coefficient may be approximated by the simpler expression

$$h_{r,a} = 4\varepsilon\sigma\bar{T}^3 \quad \bar{T} = (T_s + T_{sur})/2$$

For the condition of  $\varepsilon = 0.05$ ,  $T_s = T_{sur} + 10 = 35^\circ\text{C} = 308\text{ K}$  and  $T_{sur} = 25^\circ\text{C} = 298\text{ K}$ , find that

$$h_r = 0.05 \times 5.67 \times 10^{-8} \text{ W/m}^2 \cdot \text{K}^4 (308 + 298)(308^2 + 298^2) \text{ K}^3 = 0.32 \text{ W/m}^2 \cdot \text{K} \quad <$$

$$h_{r,a} = 4 \times 0.05 \times 5.67 \times 10^{-8} \text{ W/m}^2 \cdot \text{K}^4 ((308 + 298)/2)^3 \text{ K}^3 = 0.32 \text{ W/m}^2 \cdot \text{K} \quad <$$

The free convection coefficient with  $T_s = 35^\circ\text{C}$  and  $T_\infty = T_{sur} = 25^\circ\text{C}$ , find that

$$h = 0.98\Delta T^{1/3} = 0.98(T_s - T_\infty)^{1/3} = 0.98(308 - 298)^{1/3} = 2.1 \text{ W/m}^2 \cdot \text{K} \quad <$$

For the range  $T_s - T_{sur} = 10$  to  $100^\circ\text{C}$  with  $\varepsilon = 0.05$  and  $0.9$ , the results for the coefficients are tabulated below. For this range of surface and surroundings temperatures, the radiation and free convection coefficients are of comparable magnitude for moderate values of the emissivity, say  $\varepsilon > 0.2$ . The approximate expression for the linearized radiation coefficient is valid within 2% for these conditions.

(b) The above expressions for the radiation coefficients,  $h_r$  and  $h_{r,a}$ , are used for the workpiece at  $T_s = 25^\circ\text{C}$  placed inside a furnace with walls which may vary from  $100$  to  $1000^\circ\text{C}$ . The relative error,  $(h_r - h_{r,a})/h_r$ , will be independent of the surface emissivity and is plotted as a function of  $T_{sur}$ . For  $T_{sur} > 200^\circ\text{C}$ , the approximate expression provides estimates which are in error more than 5%. The approximate expression should be used with caution, and only for surface and surrounding temperature differences of  $50$  to  $100^\circ\text{C}$ .

$T_s$ ( $^\circ\text{C}$ )	$\varepsilon$	Coefficients ( $\text{W/m}^2 \cdot \text{K}$ )		
		$h_r$	$h_{r,a}$	$h$
35	0.05	0.32	0.32	2.1
	0.9	5.7	5.7	
135	0.05	0.51	0.50	4.7
	0.9	9.2	9.0	

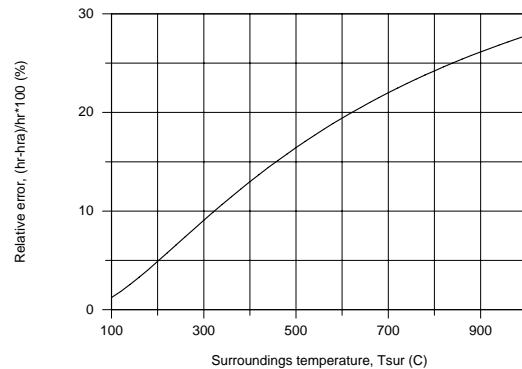

### PROBLEM 1.34

**KNOWN:** Vacuum enclosure maintained at 77 K by liquid nitrogen shroud while baseplate is maintained at 300 K by an electrical heater.

**FIND:** (a) Electrical power required to maintain baseplate, (b) Liquid nitrogen consumption rate, (c) Effect on consumption rate if aluminum foil ( $\epsilon_p = 0.09$ ) is bonded to baseplate surface.

**SCHEMATIC:**

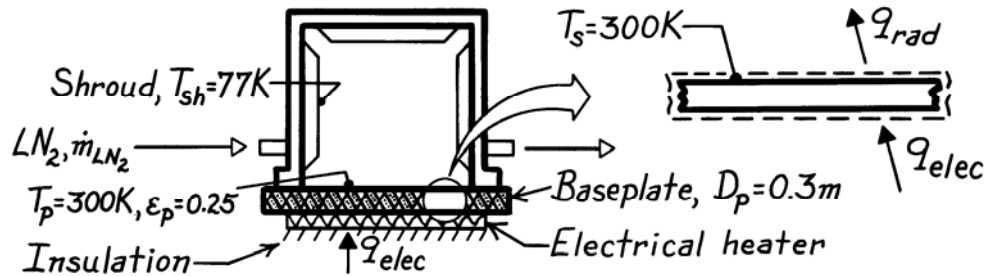

**ASSUMPTIONS:** (1) Steady-state conditions, (2) No heat losses from backside of heater or sides of plate, (3) Vacuum enclosure large compared to baseplate, (4) Enclosure is evacuated with negligible convection, (5) Liquid nitrogen ( $\text{LN}_2$ ) is heated only by heat transfer to the shroud, and (6) Foil is intimately bonded to baseplate.

**PROPERTIES:** Heat of vaporization of liquid nitrogen (given): 125 kJ/kg.

**ANALYSIS:** (a) From an energy balance on the baseplate,

$$\dot{E}_{\text{in}} - \dot{E}_{\text{out}} = 0 \quad q_{\text{elec}} - q_{\text{rad}} = 0$$

and using Eq. 1.7 for radiative exchange between the baseplate and shroud,

$$q_{\text{elec}} = \epsilon_p A_p \sigma (T_p^4 - T_{\text{sh}}^4).$$

Substituting numerical values, with  $A_p = (\pi D_p^2 / 4)$ , find

$$q_{\text{elec}} = 0.25 \left( \pi (0.3 \text{ m})^2 / 4 \right) 5.67 \times 10^{-8} \text{ W/m}^2 \cdot \text{K}^4 (300^4 - 77^4) \text{ K}^4 = 8.1 \text{ W}. \quad <$$

(b) From an energy balance on the enclosure, radiative transfer heats the liquid nitrogen stream causing evaporation,

$$\dot{E}_{\text{in}} - \dot{E}_{\text{out}} = 0 \quad q_{\text{rad}} - \dot{m}_{\text{LN}_2} h_{\text{fg}} = 0$$

where  $\dot{m}_{\text{LN}_2}$  is the liquid nitrogen consumption rate. Hence,

$$\dot{m}_{\text{LN}_2} = q_{\text{rad}} / h_{\text{fg}} = 8.1 \text{ W} / 125 \text{ kJ/kg} = 6.48 \times 10^{-5} \text{ kg/s} = 0.23 \text{ kg/h}. \quad <$$

(c) If aluminum foil ( $\epsilon_p = 0.09$ ) were bonded to the upper surface of the baseplate,

$$q_{\text{rad,foil}} = q_{\text{rad}} \left( \epsilon_f / \epsilon_p \right) = 8.1 \text{ W} (0.09 / 0.25) = 2.9 \text{ W}$$

and the liquid nitrogen consumption rate would be reduced by

$$(0.25 - 0.09) / 0.25 = 64\% \text{ to } 0.083 \text{ kg/h}. \quad <$$

### PROBLEM 1.35

**KNOWN:** Resistor connected to a battery operating at a prescribed temperature in air.

**FIND:** (a) Considering the resistor as the system, determine corresponding values for  $\dot{E}_{in}$  (W),  $\dot{E}_g$  (W),  $\dot{E}_{out}$  (W) and  $\dot{E}_{st}$  (W). If a control surface is placed about the entire system, determine the values for  $\dot{E}_{in}$ ,  $\dot{E}_g$ ,  $\dot{E}_{out}$ , and  $\dot{E}_{st}$ . (b) Determine the volumetric heat generation rate within the resistor,  $\dot{q}$  (W/m<sup>3</sup>), (c) Neglecting radiation from the resistor, determine the convection coefficient.

**SCHEMATIC:**

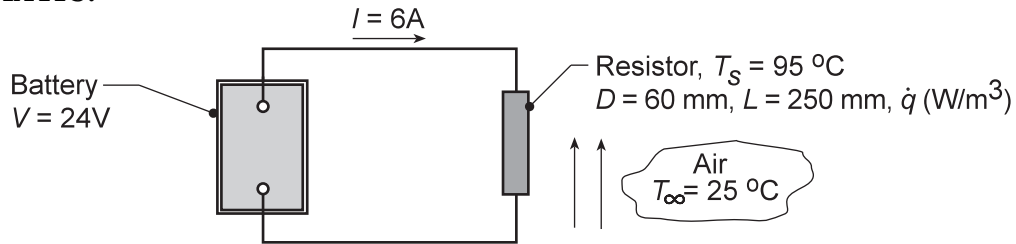

**ASSUMPTIONS:** (1) Electrical power is dissipated uniformly within the resistor, (2) Temperature of the resistor is uniform, (3) Negligible electrical power dissipated in the lead wires, (4) Negligible radiation exchange between the resistor and the surroundings, (5) No heat transfer occurs from the battery, (5) Steady-state conditions in the resistor.

**ANALYSIS:** (a) Referring to Section 1.3.1, the conservation of energy requirement for a control volume at an instant of time, Equation 1.12c, is

$$\dot{E}_{in} + \dot{E}_g - \dot{E}_{out} = \dot{E}_{st}$$

where  $\dot{E}_{in}$ ,  $\dot{E}_{out}$  correspond to *surface* inflow and outflow processes, respectively. The energy generation term  $\dot{E}_g$  is associated with conversion of some other energy form (chemical, electrical, electromagnetic or nuclear) to thermal energy. The energy storage term  $\dot{E}_{st}$  is associated with changes in the internal, kinetic and/or potential energies of the matter in the control volume.  $\dot{E}_g$ ,  $\dot{E}_{st}$  are *volumetric* phenomena. The electrical power delivered by the battery is  $P = VI = 24V \times 6A = 144$  W.

*Control volume: Resistor.*

$$\begin{array}{ll} \dot{E}_{in} = 0 & \dot{E}_{out} = 144 \text{ W} \\ \dot{E}_g = 144 \text{ W} & \dot{E}_{st} = 0 \end{array} \quad \leftarrow$$

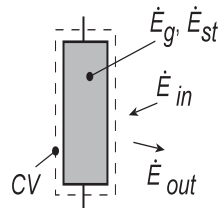

The  $\dot{E}_g$  term is due to conversion of electrical energy to thermal energy. The term  $\dot{E}_{out}$  is due to convection from the resistor surface to the air.

Continued...

**PROBLEM 1.35 (Cont.)**

Control volume: Battery-Resistor System.

$$\begin{array}{ll} \dot{E}_{in} = 0 & \dot{E}_{out} = 144 \text{ W} < \\ \dot{E}_g = 144 \text{ W} & \dot{E}_{st} = 0 \end{array}$$

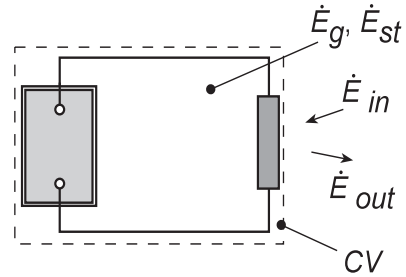

Since we are considering conservation of thermal and mechanical energy, the conversion of chemical energy to electrical energy in the battery is irrelevant, and including the battery in the control volume doesn't change the thermal and mechanical energy terms

(b) From the energy balance on the resistor with volume,  $\forall = (\pi D^2/4)L$ ,

$$\dot{E}_g = \dot{q}\forall \quad 144 \text{ W} = \dot{q} \left( \pi (0.06 \text{ m})^2 / 4 \right) \times 0.25 \text{ m} \quad \dot{q} = 2.04 \times 10^5 \text{ W/m}^3 <$$

(c) From the energy balance on the resistor and Newton's law of cooling with  $A_s = \pi DL + 2(\pi D^2/4)$ ,

$$\dot{E}_{out} = q_{cv} = hA_s (T_s - T_\infty)$$

$$144 \text{ W} = h \left[ \pi \times 0.06 \text{ m} \times 0.25 \text{ m} + 2 \left( \pi \times 0.06^2 \text{ m}^2 / 4 \right) \right] (95 - 25)^\circ \text{ C}$$

$$144 \text{ W} = h [0.0471 + 0.0057] \text{ m}^2 (95 - 25)^\circ \text{ C}$$

$$h = 39.0 \text{ W/m}^2 \cdot \text{K} <$$

**COMMENTS:** (1) In using the conservation of energy requirement, Equation 1.12c, it is important to recognize that  $\dot{E}_{in}$  and  $\dot{E}_{out}$  will always represent *surface* processes and  $\dot{E}_g$  and  $\dot{E}_{st}$ , *volumetric* processes. The generation term  $\dot{E}_g$  is associated with a *conversion* process from some form of energy to *thermal energy*. The storage term  $\dot{E}_{st}$  represents the rate of change of *internal kinetic, and potential energy*.

(2) From Table 1.1 and the magnitude of the convection coefficient determined from part (c), we conclude that the resistor is experiencing forced, rather than free, convection.

### PROBLEM 1.36

**KNOWN:** Inlet and outlet conditions for flow of water in a vertical tube.

**FIND:** (a) Change in combined thermal and flow work, (b) change in mechanical energy, and (c) change in total energy of the water from the inlet to the outlet of the tube, (d) heat transfer rate,  $q$ .

**SCHEMATIC:**

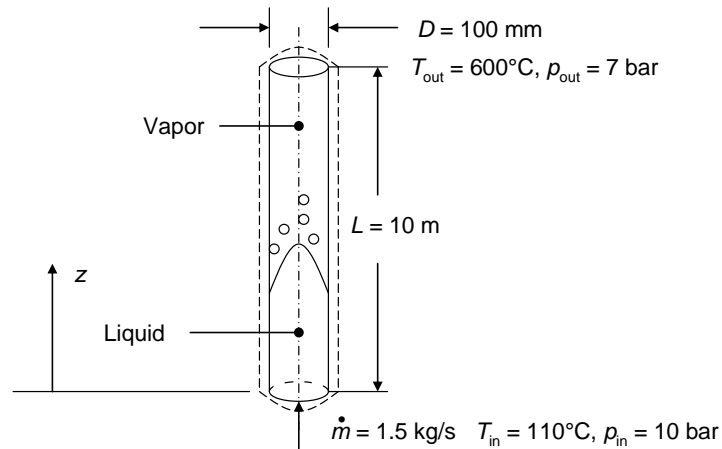

**ASSUMPTIONS:** (1) Steady-state conditions, (2) Uniform velocity distributions at the tube inlet and outlet.

**PROPERTIES:** Table A.6 water ( $T = 110^\circ\text{C}$ ):  $\rho = 950 \text{ kg/m}^3$ , ( $T = (179.9^\circ\text{C} + 110^\circ\text{C})/2 = 145^\circ\text{C}$ ):  $c_p = 4300 \text{ J/kg}\cdot\text{K}$ ,  $\rho = 919 \text{ kg/m}^3$ . Other properties are taken from Moran, M.J. and Shapiro, H.N., *Fundamentals of Engineering Thermodynamics*, 6<sup>th</sup> Edition, John Wiley & Sons, Hoboken, 2008 including ( $p_{\text{sat}} = 10 \text{ bar}$ ):  $T_{\text{sat}} = 179.9^\circ\text{C}$ ,  $i_f = 762.81 \text{ kJ/kg}$ ; ( $p = 7 \text{ bar}$ ,  $T = 600^\circ\text{C}$ ):  $i = 3700.2 \text{ kJ/kg}$ ,  $\nu = 0.5738 \text{ m}^3/\text{kg}$ .

**ANALYSIS:** The steady-flow energy equation, in the absence of work (other than flow work), is

$$\begin{aligned} \dot{m}\left(u + pv + \frac{1}{2}V^2 + gz\right)_{\text{in}} - \dot{m}\left(u + pv + \frac{1}{2}V^2 + gz\right)_{\text{out}} + q &= 0 \\ \dot{m}\left(i + \frac{1}{2}V^2 + gz\right)_{\text{in}} - \dot{m}\left(i + \frac{1}{2}V^2 + gz\right)_{\text{out}} + q &= 0 \end{aligned} \quad (1)$$

while the conservation of mass principle yields

$$V_{\text{in}} = \frac{4\dot{m}}{\rho\pi D^2} = \frac{4 \times 1.5 \text{ kg/s}}{950 \text{ kg/m}^3 \times \pi \times (0.100 \text{ m})^2} = 0.201 \text{ m/s}; \quad V_{\text{out}} = \frac{\nu 4\dot{m}}{\pi D^2} = \frac{0.5738 \text{ m}^3/\text{kg} \times 4 \times 1.5 \text{ kg/s}}{\pi \times (0.100 \text{ m})^2} = 110 \text{ m/s}$$

(a) The change in the combined thermal and flow work energy from inlet to outlet:

$$\begin{aligned} E_{i,\text{out}} - E_{i,\text{in}} &= \dot{m}(i)_{\text{out}} - \dot{m}(i)_{\text{in}} = \dot{m}(i)_{\text{out}} - \dot{m}[i_{f,\text{sat}} + c_p(T_{\text{in}} - T_{\text{sat}})] \\ &= 1.5 \text{ kg/s} \times (3700.2 \text{ kJ/kg} - [762.81 \text{ kJ/kg} + 4.3 \text{ kJ/kg}\cdot\text{K} \times (110 - 179.9)^\circ\text{C}]) < \\ &= 4.86 \text{ MW} \end{aligned}$$

where  $i_{f,\text{sat}}$  is the enthalpy of saturated liquid at the phase change temperature and pressure.

(b) The change in mechanical energy from inlet to outlet is:

Continued...



**PROBLEM 1.36 (cont.)**

$$\begin{aligned} E_{m,\text{out}} - E_{m,\text{in}} &= \dot{m} \left( \frac{1}{2} V^2 + gz \right)_{\text{out}} - \dot{m} \left( \frac{1}{2} V^2 + gz \right)_{\text{in}} \\ &= 1.5 \text{ kg/s} \times \left( \frac{1}{2} \left[ (110 \text{ m/s})^2 - (0.201 \text{ m/s})^2 \right] + 9.8 \text{ m/s}^2 \times 10 \text{ m} \right) = 9.22 \text{ kW} \end{aligned} \quad <$$

(c) The change in the total energy is the summation of the thermal, flow work, and mechanical energy change or

$$E_{\text{in}} - E_{\text{out}} = 4.86 \text{ MW} + 9.22 \text{ kW} = 4.87 \text{ MW} \quad <$$

(d) The total heat transfer rate is the same as the total energy change,  $q = E_{\text{in}} - E_{\text{out}} = 4.87 \text{ MW}$  <

**COMMENTS:** (1) The change in mechanical energy, consisting of kinetic and potential energy components, is negligible compared to the change in thermal and flow work energy. (2) The average heat flux at the tube surface is  $q'' = q / (\pi DL) = 4.87 \text{ MW} / (\pi \times 0.100 \text{ m} \times 10 \text{ m}) = 1.55 \text{ MW/m}^2$ , which is very large. (3) The change in the velocity of the water is inversely proportional to the change in the density. As such, the outlet velocity is very large, and large pressure drops will occur in the vapor region of the tube relative to the liquid region of the tube.

### PROBLEM 1.37

**KNOWN:** Flow of water in a vertical tube. Tube dimensions. Mass flow rate. Inlet pressure and temperature. Heat rate. Outlet pressure.

**FIND:** (a) Outlet temperature, (b) change in combined thermal and flow work, (c) change in mechanical energy, and (d) change in total energy of the water from the inlet to the outlet of the tube.

**SCHEMATIC:**

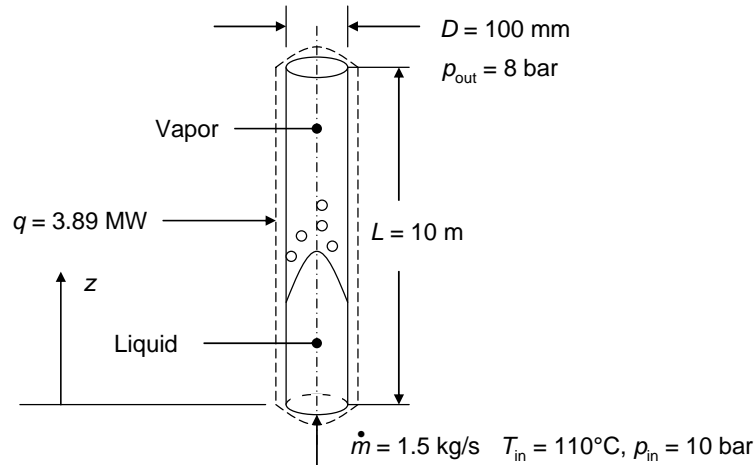

**ASSUMPTIONS:** (1) Steady-state conditions, (2) Negligible change in mechanical energy. (3) Uniform velocity distributions at the tube inlet and outlet.

**PROPERTIES:** Table A.6 water ( $T = 110^\circ\text{C}$ ):  $\rho = 950 \text{ kg/m}^3$ , ( $T = (179.9^\circ\text{C} + 110^\circ\text{C})/2 = 145^\circ\text{C}$ ):  $c_p = 4300 \text{ J/kg}\cdot\text{K}$ ,  $\rho = 919 \text{ kg/m}^3$ . Other properties are taken from Moran, M.J. and Shapiro, H.N., *Fundamentals of Engineering Thermodynamics*, 6<sup>th</sup> Edition, John Wiley & Sons, Hoboken, 2008 including ( $p_{\text{sat}} = 10 \text{ bar}$ ):  $T_{\text{sat}} = 179.9^\circ\text{C}$ ,  $i_f = 762.81 \text{ kJ/kg}$ ; ( $p = 8 \text{ bar}$ ,  $i = 3056 \text{ kJ/kg}$ ):  $T = 300^\circ\text{C}$ ,  $v = 0.3335 \text{ m}^3/\text{kg}$ .

**ANALYSIS:** (a) The steady-flow energy equation, in the absence of work (other than flow work), is

$$\begin{aligned} \dot{m}\left(u + pv + \frac{1}{2}V^2 + gz\right)_{\text{in}} - \dot{m}\left(u + pv + \frac{1}{2}V^2 + gz\right)_{\text{out}} + q &= 0 \\ \dot{m}\left(i + \frac{1}{2}V^2 + gz\right)_{\text{in}} - \dot{m}\left(i + \frac{1}{2}V^2 + gz\right)_{\text{out}} + q &= 0 \end{aligned} \quad (1)$$

Neglecting the change in mechanical energy yields

$$\dot{m}(i_{\text{in}} - i_{\text{out}}) + q = 0$$

The inlet enthalpy is

$$i_{\text{in}} = i_{f,\text{in}} + c_p(T_{\text{in}} - T_{\text{sat}}) = 762.81 \text{ kJ/kg} + 4.3 \text{ kJ/kg}\cdot\text{K} \times (110 - 179.9)^\circ\text{C} = 462.2 \text{ kJ/kg}$$

Thus the outlet enthalpy is

$$i_{\text{out}} = i_{\text{in}} + q / \dot{m} = 462.2 \text{ kJ/kg} + 3890 \text{ kW} / 1.5 \text{ kg/s} = 3056 \text{ kJ/kg}$$

Continued...

### PROBLEM 1.37 (cont.)

and the outlet temperature can be found from thermodynamic tables at  $p = 8$  bars,  $i = 3056$  kJ/kg, for which

$$T_{\text{out}} = 300^\circ\text{C}$$

(b) The change in the combined thermal and flow work energy from inlet to outlet:

$$E_{i,\text{out}} - E_{i,\text{in}} = \dot{m}(i_{\text{out}} - i_{\text{in}}) = q = 3.89 \text{ MW} \quad <$$

(c) The change in mechanical energy can now be calculated. First, the outlet specific volume can be found from thermodynamic tables at  $T_{\text{out}} = 300^\circ\text{C}$ ,  $p_{\text{out}} = 8$  bars,  $\nu = 0.3335 \text{ m}^3/\text{kg}$ . Next, the conservation of mass principle yields

$$V_{\text{in}} = \frac{4\dot{m}}{\rho\pi D^2} = \frac{4 \times 1.5 \text{ kg/s}}{950 \text{ kg/m}^3 \times \pi \times (0.100 \text{ m})^2} = 0.201 \text{ m/s}; \quad V_{\text{out}} = \frac{\nu 4\dot{m}}{\pi D^2} = \frac{0.5738 \text{ m}^3/\text{kg} \times 4 \times 1.5 \text{ kg/s}}{\pi \times (0.100 \text{ m})^2} = 63.7 \text{ m/s}$$

The change in mechanical energy from inlet to outlet is:

$$\begin{aligned} E_{m,\text{out}} - E_{m,\text{in}} &= \dot{m}\left(\frac{1}{2}V^2 + gz\right)_{\text{out}} - \dot{m}\left(\frac{1}{2}V^2 + gz\right)_{\text{in}} \\ &= 1.5 \text{ kg/s} \times \left(\frac{1}{2}\left[(63.7 \text{ m/s})^2 - (0.201 \text{ m/s})^2\right] + 9.8 \text{ m/s}^2 \times 10 \text{ m}\right) = 3.19 \text{ kW} \quad < \end{aligned}$$

(d) The change in the total energy is the summation of the thermal, flow work, and mechanical energy change or

$$E_{\text{in}} - E_{\text{out}} = 3.89 \text{ MW} + 3.19 \text{ kW} = 3.89 \text{ MW} \quad <$$

**COMMENTS:** (1) The change in mechanical energy, consisting of kinetic and potential energy components, is negligible compared to the change in thermal and flow work energy. (2) The average heat flux at the tube surface is  $q'' = q / (\pi DL) = 3.89 \text{ MW} / (\pi \times 0.100 \text{ m} \times 10 \text{ m}) = 1.24 \text{ MW/m}^2$ , which is very large. (3) The change in the velocity of the water is inversely proportional to the change in the density. As such, the outlet velocity is very large, and large pressure drops will occur in the vapor region of the tube relative to the liquid region of the tube.

### PROBLEM 1.38

**KNOWN:** Hot and cold reservoir temperatures of an internally reversible refrigerator. Thermal resistances between refrigerator and hot and cold reservoirs.

**FIND:** Expressions for modified Coefficient of Performance and power input of refrigerator.

**SCHEMATIC:**

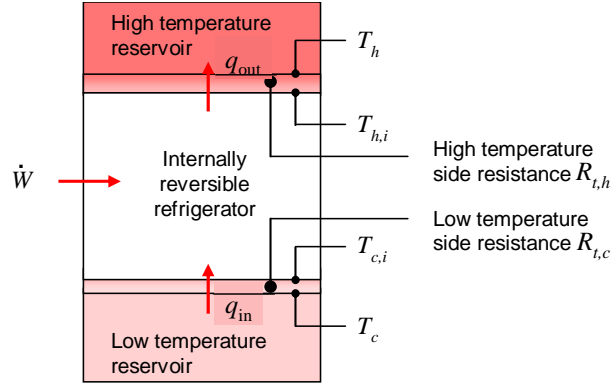

**ASSUMPTIONS:** (1) Refrigerator is internally reversible, (2) Steady-state operation.

**ANALYSIS:** Heat is transferred from the low temperature reservoir (the refrigerated space) at  $T_c$  to the refrigerator unit, through the resistance  $R_{t,c}$ , with  $T_c > T_{c,i}$ . Heat is rejected from the refrigerator unit to the higher temperature reservoir (the surroundings), through the resistance  $R_{t,h}$ , with  $T_{h,i} > T_h$ . The heat input and output rates can be expressed in a manner analogous to Equations 1.18a and 1.18b.

$$q_{in} = (T_c - T_{c,i}) / R_{t,c} \quad (1)$$

$$q_{out} = (T_{h,i} - T_h) / R_{t,h} \quad (2)$$

Equations (1) and (2) can be solved for the internal temperatures, to yield

$$T_{h,i} = T_h + q_{out} R_{t,h} = T_h + q_{in} R_{t,h} \left( \frac{1 + \text{COP}_m}{\text{COP}_m} \right) \quad (3)$$

$$T_{c,i} = T_c - q_{in} R_{t,c} \quad (4)$$

In Equation (3),  $q_{out}$  has been expressed as

$$q_{out} = q_{in} \left( \frac{1 + \text{COP}_m}{\text{COP}_m} \right) \quad (5)$$

using the definition of  $\text{COP}_m$  given in the problem statement. The modified Coefficient of Performance can then be expressed as

Continued...

### PROBLEM 1.38 (Cont.)

$$\text{COP}_m = \frac{T_{c,i}}{T_{h,i} - T_{c,i}} = \frac{T_c - q_{\text{in}} R_{t,c}}{T_h + q_{\text{in}} R_{t,h} \left( \frac{1 + \text{COP}_m}{\text{COP}_m} \right) - T_c + q_{\text{in}} R_{t,c}}$$

Manipulating this expression,

$$(T_h - T_c + q_{\text{in}} R_{t,c}) \text{COP}_m + q_{\text{in}} R_{t,h} (1 + \text{COP}_m) = T_c - q_{\text{in}} R_{t,c}$$

Solving for  $\text{COP}_m$  results in

$$\text{COP}_m = \frac{T_c - q_{\text{in}} R_{\text{tot}}}{T_h - T_c + q_{\text{in}} R_{\text{tot}}} \quad <$$

From the definition of  $\text{COP}_m$ , the power input can be determined:

$$\dot{W} = \frac{q_{\text{in}}}{\text{COP}_m} = q_{\text{in}} \frac{T_h - T_c + q_{\text{in}} R_{\text{tot}}}{T_c - q_{\text{in}} R_{\text{tot}}} \quad <$$

**COMMENTS:** As  $q_{\text{in}}$  or  $R_{\text{tot}}$  goes to zero, the Coefficient of Performance approaches the maximum Carnot value,  $\text{COP}_m = \text{COP}_C = T_c / (T_h - T_c)$ .

### PROBLEM 1.39

**KNOWN:** Hot and cold reservoir temperatures of an internally reversible refrigerator. Thermal resistances between refrigerator and hot and cold reservoirs under clean and dusty conditions. Desired cooling rate.

**FIND:** Modified Coefficient of Performance and power input of refrigerator under clean and dusty conditions.

**SCHEMATIC:**

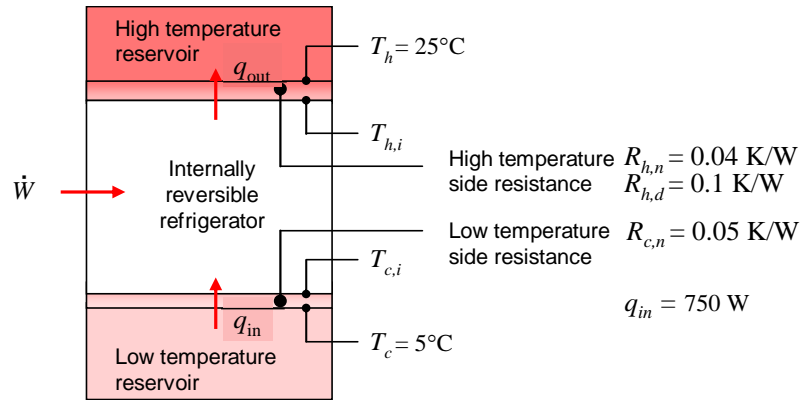

**ASSUMPTIONS:** (1) Refrigerator is internally reversible, (2) Steady-state operation, (3) Cold side thermal resistance does not degrade over time.

**ANALYSIS:** According to Problem 1.38, the modified Coefficient of Performance and power input are given by

$$\text{COP}_m = \frac{T_c - q_{\text{in}} R_{\text{tot}}}{T_h - T_c + q_{\text{in}} R_{\text{tot}}} \quad (1)$$

$$\dot{W} = q_{\text{in}} \frac{T_h - T_c + q_{\text{in}} R_{\text{tot}}}{T_c - q_{\text{in}} R_{\text{tot}}} \quad (2)$$

Under new, clean conditions, with  $R_{\text{tot},n} = R_{h,n} + R_{c,n} = 0.09 \text{ K/W}$ , we find

$$\text{COP}_{m,n} = \frac{278 \text{ K} - 750 \text{ W} \times 0.09 \text{ K/W}}{298 \text{ K} - 278 \text{ K} + 750 \text{ W} \times 0.09 \text{ K/W}} = 2.41 <$$

$$\dot{W}_n = 750 \text{ W} \frac{298 \text{ K} - 278 \text{ K} + 750 \text{ W} \times 0.09 \text{ K/W}}{278 \text{ K} - 750 \text{ W} \times 0.09 \text{ K/W}} = 312 \text{ W} <$$

Under dusty, conditions, with  $R_{\text{tot},d} = R_{h,d} + R_{c,n} = 0.15 \text{ K/W}$ , we find

$$\text{COP}_{m,d} = \frac{278 \text{ K} - 750 \text{ W} \times 0.15 \text{ K/W}}{298 \text{ K} - 278 \text{ K} + 750 \text{ W} \times 0.15 \text{ K/W}} = 1.25 <$$

Continued...

### PROBLEM 1.39 (Cont.)

$$\dot{W}_d = 750 \text{ W} \frac{298 \text{ K} - 278 \text{ K} + 750 \text{ W} \times 0.15 \text{ K/W}}{278 \text{ K} - 750 \text{ W} \times 0.15 \text{ K/W}} = 600 \text{ W} \quad <$$

**COMMENTS:** (1) The cooling rates and power input values are time-averaged quantities. Since the refrigerator does not run constantly, the instantaneous power requirements would be higher than calculated. (2) In practice, when the condenser coils become dusty the power input does not adjust to maintain the cooling rate. Rather, the refrigerator's *duty cycle* would increase. (3) The ideal Carnot Coefficient of Performance is  $\text{COP}_C = T_c / (T_h - T_c) = 14$  and the corresponding power input is 54 W. (4) This refrigerator's energy efficiency is poor. Less power would be consumed by more thoroughly insulating the refrigerator, and designing the refrigerator to minimize heat gain upon opening its door, in order to reduce the cooling rate,  $q_{in}$ .

### PROBLEM 1.40

**KNOWN:** Width, surface emissivity and maximum allowable temperature of an electronic chip. Temperature of air and surroundings. Convection coefficient.

**FIND:** (a) Maximum power dissipation for free convection with  $h(\text{W}/\text{m}^2 \cdot \text{K}) = 4.2(T - T_\infty)^{1/4}$ , (b) Maximum power dissipation for forced convection with  $h = 250 \text{ W}/\text{m}^2 \cdot \text{K}$ .

**SCHEMATIC:**

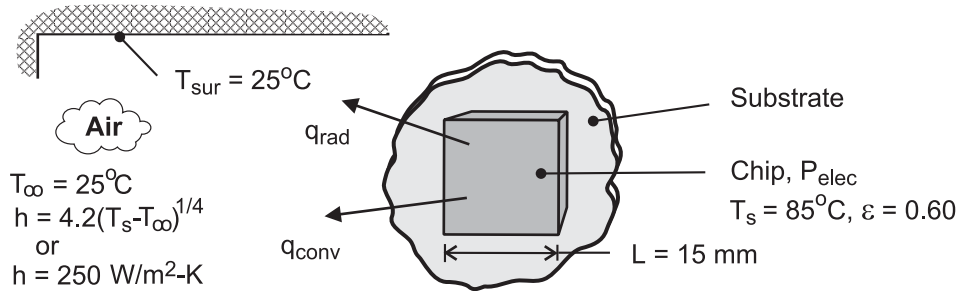

**ASSUMPTIONS:** (1) Steady-state conditions, (2) Radiation exchange between a small surface and a large enclosure, (3) Negligible heat transfer from sides of chip or from back of chip by conduction through the substrate.

**ANALYSIS:** Subject to the foregoing assumptions, electric power dissipation by the chip must be balanced by convection and radiation heat transfer from the chip. Hence, from Eq. (1.10),

$$P_{\text{elec}} = q_{\text{conv}} + q_{\text{rad}} = hA(T_s - T_\infty) + \varepsilon A \sigma (T_s^4 - T_{\text{sur}}^4)$$

where  $A = L^2 = (0.015\text{m})^2 = 2.25 \times 10^{-4} \text{ m}^2$ .

(a) If heat transfer is by natural convection,

$$q_{\text{conv}} = C A (T_s - T_\infty)^{5/4} = 4.2 \text{ W}/\text{m}^2 \cdot \text{K}^{5/4} \left( 2.25 \times 10^{-4} \text{ m}^2 \right) (60\text{K})^{5/4} = 0.158 \text{ W}$$

$$q_{\text{rad}} = 0.60 \left( 2.25 \times 10^{-4} \text{ m}^2 \right) 5.67 \times 10^{-8} \text{ W}/\text{m}^2 \cdot \text{K}^4 \left( 358^4 - 298^4 \right) \text{K}^4 = 0.065 \text{ W}$$

$$P_{\text{elec}} = 0.158 \text{ W} + 0.065 \text{ W} = 0.223 \text{ W} \quad <$$

(b) If heat transfer is by forced convection,

$$q_{\text{conv}} = hA(T_s - T_\infty) = 250 \text{ W}/\text{m}^2 \cdot \text{K} \left( 2.25 \times 10^{-4} \text{ m}^2 \right) (60\text{K}) = 3.375 \text{ W}$$

$$P_{\text{elec}} = 3.375 \text{ W} + 0.065 \text{ W} = 3.44 \text{ W} \quad <$$

**COMMENTS:** Clearly, radiation and natural convection are inefficient mechanisms for transferring heat from the chip. For  $T_s = 85^\circ\text{C}$  and  $T_\infty = 25^\circ\text{C}$ , the natural convection coefficient is  $11.7 \text{ W}/\text{m}^2 \cdot \text{K}$ . Even for forced convection with  $h = 250 \text{ W}/\text{m}^2 \cdot \text{K}$ , the power dissipation is well below that associated with many of today's processors. To provide acceptable cooling, it is often necessary to attach the chip to a highly conducting substrate and to thereby provide an additional heat transfer mechanism due to conduction from the back surface.



### PROBLEM 1.41

**KNOWN:** Width, input power and efficiency of a transmission. Temperature and convection coefficient for air flow over the casing. Emissivity of casing and temperature of surroundings.

**FIND:** Surface temperature of casing.

**SCHEMATIC:**

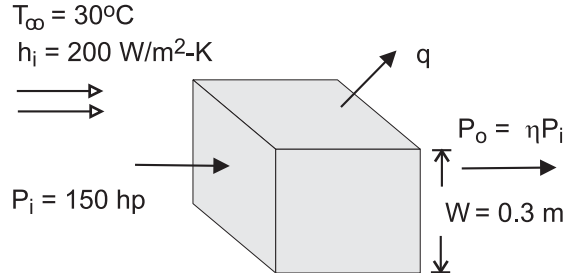

**ASSUMPTIONS:** (1) Steady state, (2) Uniform convection coefficient and surface temperature, (3) Radiation exchange with large surroundings.

**ANALYSIS:** Heat transfer from the case must balance heat dissipation in the transmission, which may be expressed as  $q = P_i - P_o = P_i (1 - \eta) = 150 \text{ hp} \times 746 \text{ W/hp} \times 0.07 = 7833 \text{ W}$ . Heat transfer from the case is by convection and radiation, in which case

$$q = A_s \left[ h(T_s - T_\infty) + \varepsilon\sigma(T_s^4 - T_{\text{sur}}^4) \right]$$

where  $A_s = 6 \text{ m}^2$ . Hence,

$$7833 \text{ W} = 6(0.30 \text{ m})^2 \left[ 200 \text{ W/m}^2 \cdot \text{K}(T_s - 303\text{K}) + 0.8 \times 5.67 \times 10^{-8} \text{ W/m}^2 \cdot \text{K}^4 (T_s^4 - 303^4) \text{K}^4 \right]$$

A trial-and-error solution yields

$$T_s \approx 373 \text{ K} = 100^\circ\text{C}$$

<

**COMMENTS:** (1) For  $T_s \approx 373 \text{ K}$ ,  $q_{\text{conv}} \approx 7,560 \text{ W}$  and  $q_{\text{rad}} \approx 270 \text{ W}$ , in which case heat transfer is dominated by convection, (2) If radiation is neglected, the corresponding surface temperature is  $T_s = 102.5^\circ\text{C}$ .

## PROBLEM 1.42

**KNOWN:** Process for growing thin, photovoltaic grade silicon sheets. Sheet dimensions and velocity. Dimensions, surface temperature and surface emissivity of growth chamber. Surroundings and ambient temperatures, and convective heat transfer coefficient. Amount of time-averaged absorbed solar irradiation and photovoltaic conversion efficiency.

**FIND:** (a) Electric power needed to operate at steady state, (b) Time needed to operate the photovoltaic panel to produce enough energy to offset energy consumed during its manufacture.

**SCHEMATIC:**

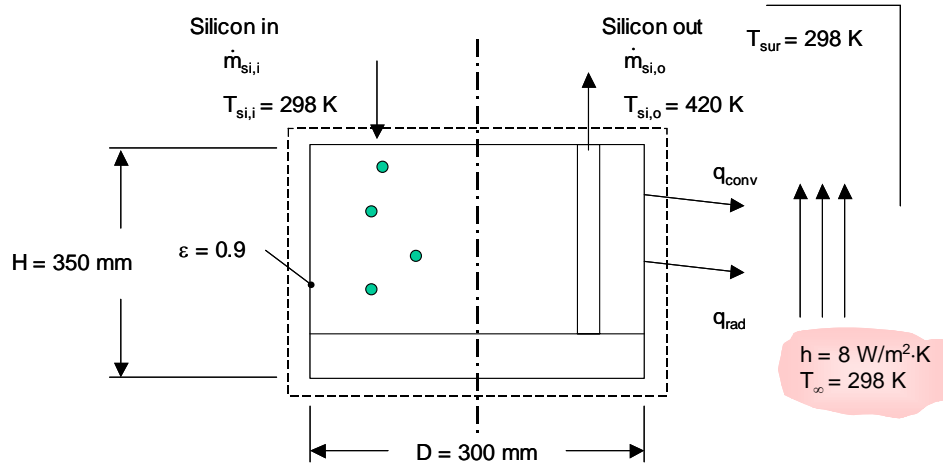

**ASSUMPTIONS:** (1) Steady-state conditions, (2) Large surroundings, (3) Constant properties, (4) Neglect the presence of the strings.

**PROPERTIES:** Table A-1, Silicon ( $T = 298 \text{ K}$ ):  $c = 712 \text{ J/kg}\cdot\text{K}$ ,  $\rho = 2330 \text{ kg/m}^3$ , ( $T = 420 \text{ K}$ ):  $c = 798 \text{ J/kg}\cdot\text{K}$ .

**ANALYSIS:** (a) At steady state, the mass of silicon produced per unit time is equal to the mass of silicon added to the system per unit time. The amount of silicon produced is

$$\dot{m} = W_{\text{si}} \times t_{\text{si}} \times V_{\text{si}} \times \rho = 0.085 \text{ m} \times 150 \times 10^{-6} \text{ m} \times 0.020 \text{ m/min} \times (1/60) \text{ min/s} \times 2330 \text{ kg/m}^3 = 9.90 \times 10^{-6} \text{ kg/s}$$

At steady state,  $\dot{E}_{\text{in}} = \dot{E}_{\text{out}}$  where

$$\dot{E}_{\text{in}} = P_{\text{elec}} + \dot{m}cT_{\text{si},i} = P_{\text{elec}} + 9.90 \times 10^{-6} \frac{\text{kg}}{\text{s}} \times 712 \frac{\text{J}}{\text{kg}\cdot\text{K}} \times 298 \text{ K} = P_{\text{elec}} + 2.10 \text{ J/s} = P_{\text{elec}} + 2.10 \text{ W}$$

and

$$\begin{aligned} \dot{E}_{\text{out}} &= \dot{m}cT_{\text{si},o} + \left[ 2\pi D^2/4 + H\pi D \right] \left[ h(T_s - T_{\infty}) + \epsilon\sigma(T_s^4 - T_{\text{sur}}^4) \right] \\ &= 9.9 \times 10^{-6} \frac{\text{kg}}{\text{s}} \times 798 \frac{\text{J}}{\text{kg}\cdot\text{K}} \times 420 \text{ K} + \left[ 2\pi \times (0.3 \text{ m})^2/4 + 0.35 \text{ m} \times \pi \times 0.3 \text{ m} \right] \\ &\quad \times \left[ 8 \frac{\text{W}}{\text{m}^2\cdot\text{K}} \times (320 - 298) \text{ K} + 5.67 \times 10^{-8} \frac{\text{W}}{\text{m}^2\cdot\text{K}^4} \times 0.9 \times \left( (420 \text{ K})^4 - (298 \text{ K})^4 \right) \right] = 645 \text{ W} \end{aligned}$$

Therefore,

Continued...

### PROBLEM 1.42 (Cont.)

$$P_{\text{elec}} = 645 \text{ W} - 2.10 \text{ W} = 643 \text{ W}$$

&lt;

(b) The electric energy needed to manufacture the photovoltaic material is

$$E_m = P_{\text{elec}} / (W_s V_s) = 643 \text{ W} / (0.085 \text{ m} \times 0.020 \text{ m/min} \times (1/60) \text{ min/s}) = 22.7 \times 10^6 \text{ J/m}^2 = 22.7 \times 10^3 \text{ kJ/m}^2$$

The time needed to generate  $E_m$  by the photovoltaic panel is

$$t = E_m / q_{\text{sol}}'' \eta = 22.7 \times 10^6 \text{ J/m}^2 / (180 \text{ W/m}^2 \times 0.20) = 630 \times 10^3 \text{ s} = 175 \text{ h}$$

&lt;

**COMMENTS:** (1) The radiation and convection losses are primarily responsible for the electric power needed to manufacture the photovoltaic material. Of these, radiation losses dominate, with radiation responsible for 87% of the losses. The radiation losses could be reduced by coating the exposed surface of the chamber with a low emissivity material. (2) Assuming an electricity cost of \$0.15/kWh, the electric cost to manufacture the material is  $22.7 \times 10^3 \text{ kJ/m}^2 \times (\$0.15/\text{kWh}) \times (1\text{h}/3600\text{s}) = \$0.95/\text{m}^2$ . (3) In this solution, a reference state of 0 K is tacitly assumed for the silicon for the energy inflow and outflow terms, however the reference state for the equations for energy inflow and outflow cancel. (4) This problem represents a type of *life cycle analysis* in which the energy consumed to manufacture a product is of interest. The analysis presented here does not account for the energy that is consumed to produce the silicon powder, the energy used to fabricate the growth chamber, or the energy that is used to fabricate and install the photovoltaic panel. The actual time needed to offset the energy to manufacture and install the photovoltaic panel will be much greater than 175 h. See Keoleian and Leis, "Application of Life-cycle Energy Analysis to Photovoltaic Module Design, *Progress in Photovoltaics: Research and Applications*, Vol. 5, pp. 287-300, 1997.

## PROBLEM 1.43

**KNOWN:** Surface areas, convection heat transfer coefficient, surface emissivity of gear box and generator. Temperature of nacelle. Electric power generated by the wind turbine and generator efficiency.

**FIND:** Gear box and generator surface temperatures.

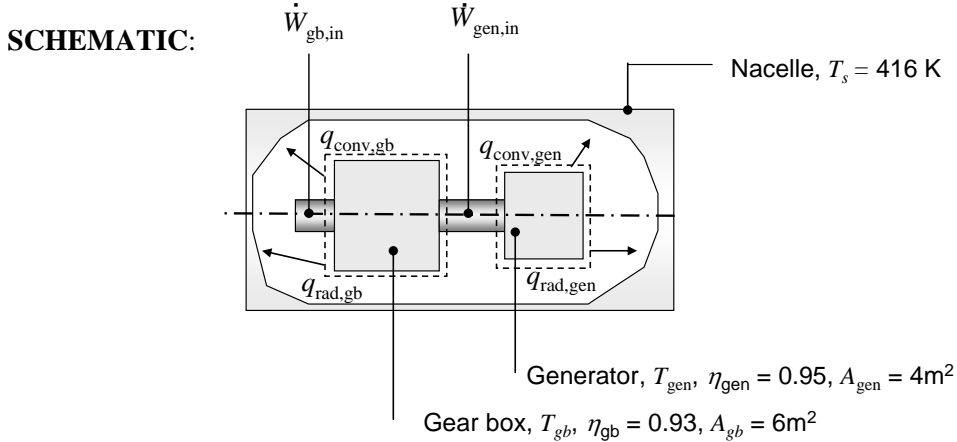

**ASSUMPTIONS:** (1) Steady-state conditions, (2) Interior of nacelle can be treated as large surroundings, (3) Negligible heat transfer between the gear box and the generator.

**ANALYSIS:** Heat is generated within both the gear box and the generator. The mechanical work into the generator can be determined from the electrical power,  $P = 2.5 \times 10^6 \text{ W}$ , and the efficiency of the generator as

$$\dot{W}_{\text{gen,in}} = P / \eta_{\text{gen}} = 2.5 \times 10^6 \text{ W} / 0.95 = 2.63 \times 10^6 \text{ W}$$

Therefore, the heat transfer from the generator is

$$q_{\text{gen}} = \dot{W}_{\text{gen}} - P = 2.63 \times 10^6 \text{ W} - 2.5 \times 10^6 \text{ W} = 0.13 \times 10^6 \text{ W}$$

The heat transfer is composed of convection and radiation components. Hence,

$$\begin{aligned} q_{\text{gen}} &= A_{\text{gen}} \left[ h(T_{\text{gen}} - T_s) + \varepsilon \sigma (T_{\text{gen}}^4 - T_s^4) \right] \\ &= 4 \text{ m}^2 \times \left[ 40 \frac{\text{W}}{\text{m}^2 \cdot \text{K}} (T_{\text{gen}} - 416 \text{ K}) + 0.90 \times 5.67 \times 10^{-8} \frac{\text{W}}{\text{m}^2 \cdot \text{K}^4} (T_{\text{gen}}^4 - (416 \text{ K})^4) \right] \\ &= 0.13 \times 10^6 \text{ W} \end{aligned}$$

The generator surface temperature may be found by using a numerical solver, or by trial-and-error, yielding

$$T_{\text{gen}} = 785 \text{ K} = 512^\circ \text{C}$$

<

Continued...

### PROBLEM 1.43 (Cont.)

Heat is also generated by the gear box. The heat generated in the gear box may be determined from knowledge of the heat generated cumulatively by the gear box and the generator, which is provided in Example 3.1 and is  $q = q_{\text{gen}} + q_{\text{gb}} = 0.33 \times 10^6 \text{ W}$ . Hence,  $q_{\text{gb}} = q - q_{\text{gen}} = 0.33 \times 10^6 \text{ W} - 0.13 \times 10^6 \text{ W} = 0.20 \times 10^6 \text{ W}$  and

$$\begin{aligned} q_{\text{gb}} &= A_{\text{gb}} \left[ h(T_{\text{gb}} - T_s) + \varepsilon\sigma(T_{\text{gb}}^4 - T_s^4) \right] \\ &= 6\text{m}^2 \times \left[ 40 \frac{\text{W}}{\text{m}^2 \cdot \text{K}} (T_{\text{gb}} - 416\text{K}) + 0.90 \times 5.67 \times 10^{-8} \frac{\text{W}}{\text{m}^2 \cdot \text{K}^4} (T_{\text{gb}}^4 - (416\text{K})^4) \right] \\ &= 0.20 \times 10^6 \text{ W} \end{aligned}$$

which may be solved by trial-and-error or with a numerical solver to find

$$T_{\text{gb}} = 791 \text{ K} = 518^\circ\text{C}$$

<

**COMMENTS:** (1) The gear box and generator temperatures are unacceptably high. Thermal management must be employed in order to generate power from the wind turbine. (2) The gear box and generator temperatures are of similar value. Hence, the assumption that heat transfer between the two mechanical devices is small is valid. (3) The radiation and convection heat transfer rates are of similar value. For the generator, convection and radiation heat transfer rates are  $q_{\text{conv,gen}} = 5.9 \times 10^4 \text{ W}$  and  $q_{\text{rad,gen}} = 7.1 \times 10^4 \text{ W}$ , respectively. The convection and radiation heat transfer rates are  $q_{\text{conv,gb}} = 9.0 \times 10^4 \text{ W}$  and  $q_{\text{rad,gb}} = 11.0 \times 10^4 \text{ W}$ , respectively, for the gear box. It would be a poor assumption to neglect either convection or radiation in the analysis.

### PROBLEM 1.44

**KNOWN:** Radial distribution of heat dissipation in a cylindrical container of radioactive wastes. Surface convection conditions.

**FIND:** Total energy generation rate and surface temperature.

**SCHEMATIC:**

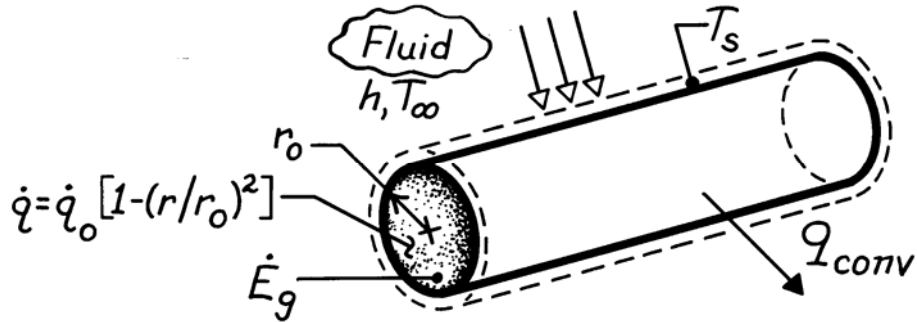

**ASSUMPTIONS:** (1) Steady-state conditions, (2) Negligible temperature drop across thin container wall.

**ANALYSIS:** The rate of energy generation is

$$\begin{aligned}\dot{E}_g &= \int \dot{q} dV = \dot{q}_o \int_0^{r_o} [1 - (r/r_o)^2] 2\pi r L dr \\ \dot{E}_g &= 2\pi L \dot{q}_o \left( r_o^2 / 2 - r_o^2 / 4 \right)\end{aligned}$$

or per unit length,

$$\dot{E}'_g = \frac{\pi \dot{q}_o r_o^2}{2}. \quad <$$

Performing an energy balance for a control surface about the container yields, at an instant,

$$\dot{E}'_g - \dot{E}'_{out} = 0$$

and substituting for the convection heat rate per unit length,

$$\begin{aligned}\frac{\pi \dot{q}_o r_o^2}{2} &= h(2\pi r_o)(T_s - T_\infty) \\ T_s &= T_\infty + \frac{\dot{q}_o r_o}{4h}. \quad <\end{aligned}$$

**COMMENTS:** The temperature within the radioactive wastes increases with decreasing  $r$  from  $T_s$  at  $r_o$  to a maximum value at the centerline.

## PROBLEM 1.45

**KNOWN:** Thickness and initial temperature of an aluminum plate whose thermal environment is changed.

**FIND:** (a) Initial rate of temperature change, (b) Steady-state temperature of plate, (c) Effect of emissivity and absorptivity on steady-state temperature.

**SCHEMATIC:**

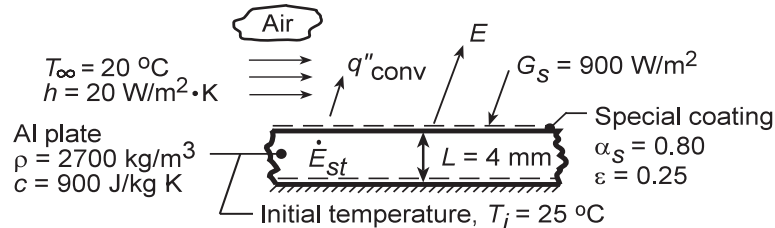

**ASSUMPTIONS:** (1) Negligible end effects, (2) Uniform plate temperature at any instant, (3) Constant properties, (4) Adiabatic bottom surface, (5) Negligible radiation from surroundings, (6) No internal heat generation.

**ANALYSIS:** (a) Applying an energy balance, Eq. 1.12c, at an instant of time to a control volume about the plate,  $\dot{E}_{in} - \dot{E}_{out} = \dot{E}_{st}$ , it follows for a unit surface area.

$$\alpha_S G_S (1 \text{ m}^2) - E (1 \text{ m}^2) - q''_{conv} (1 \text{ m}^2) = (d/dt)(McT) = \rho (1 \text{ m}^2 \times L) c (dT/dt).$$

Rearranging and substituting from Eqs. 1.3 and 1.5, we obtain

$$dT/dt = (1/\rho Lc) \left[ \alpha_S G_S - \epsilon \sigma T_i^4 - h(T_i - T_\infty) \right].$$

$$dT/dt = \left( 2700 \text{ kg/m}^3 \times 0.004 \text{ m} \times 900 \text{ J/kg} \cdot \text{K} \right)^{-1} \times$$

$$\left[ 0.8 \times 900 \text{ W/m}^2 - 0.25 \times 5.67 \times 10^{-8} \text{ W/m}^2 \cdot \text{K}^4 (298 \text{ K})^4 - 20 \text{ W/m}^2 \cdot \text{K} (25 - 20)^\circ \text{C} \right]$$

$$dT/dt = 0.052^\circ \text{C/s}.$$

(b) Under steady-state conditions,  $\dot{E}_{st} = 0$ , and the energy balance reduces to

$$\alpha_S G_S = \epsilon \sigma T^4 + h(T - T_\infty) \quad (2)$$

$$0.8 \times 900 \text{ W/m}^2 = 0.25 \times 5.67 \times 10^{-8} \text{ W/m}^2 \cdot \text{K}^4 \times T^4 + 20 \text{ W/m}^2 \cdot \text{K} (T - 293 \text{ K})$$

The solution yields  $T = 321.4 \text{ K} = 48.4^\circ \text{C}$ .

(c) Using the IHT *First Law Model* for an *Isothermal Plane Wall*, parametric calculations yield the following results.

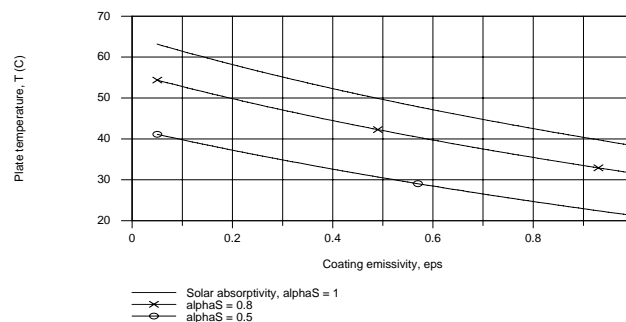

**COMMENTS:** The surface radiative properties have a significant effect on the plate temperature, which decreases with increasing  $\epsilon$  and decreasing  $\alpha_S$ . If a low temperature is desired, the plate coating should be characterized by a large value of  $\epsilon/\alpha_S$ . The temperature also decreases with increasing  $h$ .

### PROBLEM 1.46

**KNOWN:** Blood inlet and outlet temperatures and flow rate. Dimensions of tubing.

**FIND:** Required rate of heat addition and estimate of kinetic and potential energy changes.

**SCHEMATIC:**

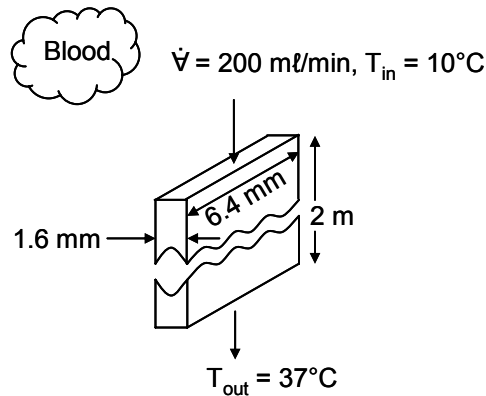

**ASSUMPTIONS:** (1) Steady-state conditions, (2) Incompressible liquid with negligible kinetic and potential energy changes, (3) Blood has properties of water.

**PROPERTIES:** Table A.6, Water ( $\bar{T} \approx 300 \text{ K}$ ):  $c_{p,f} = 4179 \text{ J/kg}\cdot\text{K}$ ,  $\rho_f = 1/v_f = 997 \text{ kg/m}^3$ .

**ANALYSIS:** From an overall energy balance, Equation 1.12e,

$$q = \dot{m}c_p(T_{out} - T_{in})$$

where

$$\dot{m} = \rho_f \dot{V} = 997 \text{ kg/m}^3 \times 200 \text{ ml/min} \times 10^{-6} \text{ m}^3/\text{ml} / 60 \text{ s/min} = 3.32 \times 10^{-3} \text{ kg/s}$$

Thus

$$q = 3.32 \times 10^{-3} \text{ kg/s} \times 4179 \text{ J/kg}\cdot\text{K} \times (37^{\circ}\text{C} - 10^{\circ}\text{C}) = 375 \text{ W} \quad <$$

The velocity in the tube is given by

$$V = \dot{V}/A_c = 200 \text{ ml/min} \times 10^{-6} \text{ m}^3/\text{ml} / (60 \text{ s/min} \times 6.4 \times 10^{-3} \text{ m} \times 1.6 \times 10^{-3} \text{ m}) = 0.33 \text{ m/s}$$

The change in kinetic energy is

$$\dot{m}\left(\frac{1}{2}V^2 - 0\right) = 3.32 \times 10^{-3} \text{ kg/s} \times \frac{1}{2} \times (0.33 \text{ m/s})^2 = 1.8 \times 10^{-4} \text{ W} \quad <$$

The change in potential energy is

$$\dot{m}gz = 3.32 \times 10^{-3} \text{ kg/s} \times 9.8 \text{ m/s}^2 \times 2 \text{ m} = 0.065 \text{ W} \quad <$$

**COMMENT:** The kinetic and potential energy changes are both negligible relative to the thermal energy change.



## PROBLEM 1.47

**KNOWN:** Dimensions of a milk carton. Temperatures of milk carton and surrounding air. Convection heat transfer coefficient and surface emissivity.

**FIND:** Heat transferred to milk carton for durations of 10, 60, and 300 s.

**SCHEMATIC:**

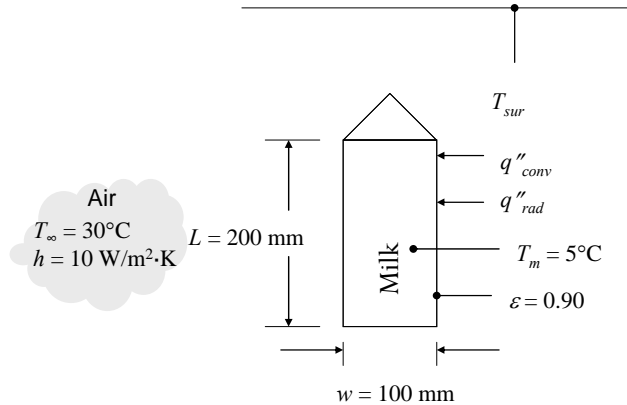

**ASSUMPTIONS:** (1) Negligible heat transfer from bottom surface of milk carton and from top surface since it is not in contact with cold milk, (2) Radiation is to large surroundings at the air temperature.

**ANALYSIS:** The area of the four sides is  $A = 4L \times w = 4(0.2 \text{ m} \times 0.1 \text{ m}) = 0.08 \text{ m}^2$ . Thus,

$$\begin{aligned} q &= (q_{\text{conv}} + q_{\text{rad}}) = hA(T_{\infty} - T_s) + \epsilon\sigma A(T_{\text{sur}}^4 - T_s^4) \\ &= 10 \text{ W/m}^2 \cdot \text{K} \times 0.08 \text{ m}^2 (30^\circ\text{C} - 5^\circ\text{C}) + 0.90 \times 5.67 \times 10^{-8} \text{ W/m}^2 \cdot \text{K}^4 \times 0.08 \text{ m}^2 \left( (303 \text{ K})^4 - (278 \text{ K})^4 \right) \\ &= 20.0 \text{ W} + 10.0 \text{ W} = 30.0 \text{ W} \end{aligned}$$

For a duration of 10 s,

$$Q = q\Delta t = 30.0 \text{ W} \times 10 \text{ s} = 300 \text{ J} \quad \leftarrow$$

Similarly,  $Q = 1800 \text{ J}$  and  $9000 \text{ J}$  for durations of 60 and 300 s, respectively. ←

**COMMENTS:** (1) The predicted heat transfer rates do not account for the fact that the milk temperature increases with time. If the increase in milk temperature were accounted for, the values of  $Q$  would be less than calculated. (2) If the coefficient of performance of the refrigerator is 2,  $\text{COP} = Q/W = 2$ , then the required work input to re-cool the milk after leaving it in the kitchen for 300 s is 4500 J. At an electricity price of  $\$0.18/\text{kW}\cdot\text{h}$ , this would cost about  $\$0.0002$ , which is insignificant. Preventing bacterial growth is a more important reason to return the milk to the refrigerator promptly. (3) The analysis neglects condensation that might occur on the outside of the milk carton. Condensation would increase the rate of heat transfer to the milk significantly, increasing the importance of returning the milk to the refrigerator promptly.

### PROBLEM 1.48

**KNOWN:** Daily hot water consumption for a family of four and temperatures associated with ground water and water storage tank. Unit cost of electric power. Heat pump COP.

**FIND:** Annual heating requirement and costs associated with using electric resistance heating or a heat pump.

**SCHEMATIC:**

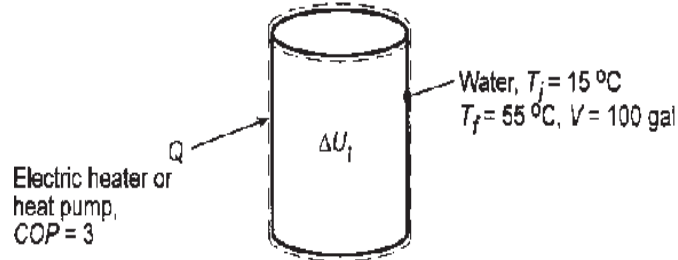

**ASSUMPTIONS:** (1) Process may be modeled as one involving heat addition in a closed system, (2) Properties of water are constant.

**PROPERTIES:** Table A-6, Water ( $T_{\text{avg}} = 308 \text{ K}$ ):  $\rho = v_f^{-1} = 993 \text{ kg/m}^3$ ,  $c_{p,f} = 4.178 \text{ kJ/kg}\cdot\text{K}$ .

**ANALYSIS:** From Eq. 1.12a, the daily heating requirement is  $Q_{\text{daily}} = \Delta U_t = Mc\Delta T = \rho Vc(T_f - T_i)$ . With  $V = 100 \text{ gal}/264.17 \text{ gal/m}^3 = 0.379 \text{ m}^3$ ,

$$Q_{\text{daily}} = 993 \text{ kg/m}^3 (0.379 \text{ m}^3) 4.178 \text{ kJ/kg}\cdot\text{K} (40^\circ \text{C}) = 62,900 \text{ kJ}$$

The annual heating requirement is then,  $Q_{\text{annual}} = 365 \text{ days} (62,900 \text{ kJ/day}) = 2.30 \times 10^7 \text{ kJ}$ , or, with  $1 \text{ kWh} = 1 \text{ kJ/s} (3600 \text{ s}) = 3600 \text{ kJ}$ ,

$$Q_{\text{annual}} = 6380 \text{ kWh} \quad <$$

With electric resistance heating,  $Q_{\text{annual}} = Q_{\text{elec}}$  and the associated cost,  $C$ , is

$$C = 6380 \text{ kWh} (\$0.18/\text{kWh}) = \$1150 \quad <$$

If a heat pump is used,  $Q_{\text{annual}} = \text{COP}(W_{\text{elec}})$ . Hence,

$$W_{\text{elec}} = Q_{\text{annual}}/(\text{COP}) = 6380 \text{ kWh}/(3) = 2130 \text{ kWh}$$

The corresponding cost is

$$C = 2130 \text{ kWh} (\$0.18/\text{kWh}) = \$383 \quad <$$

**COMMENTS:** Although annual operating costs are significantly lower for a heat pump, corresponding capital costs are higher. The feasibility of this approach depends on other factors such as geography and seasonal variations in COP, as well as the time value of money.

## PROBLEM 1.49

**KNOWN:** Boiling point and latent heat of liquid oxygen. Diameter and emissivity of container. Free convection coefficient and temperature of surrounding air and walls.

**FIND:** Mass evaporation rate.

**SCHEMATIC:**

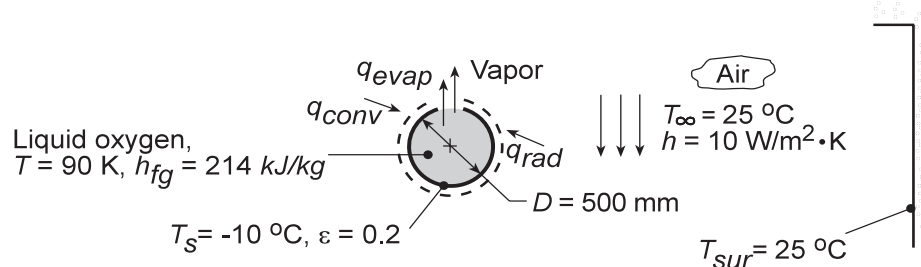

**ASSUMPTIONS:** (1) Steady-state conditions, (2) Temperature of container outer surface equals boiling point of oxygen.

**ANALYSIS:** (a) Applying mass and energy balances to a control surface about the container, it follows that, at any instant,

$$\frac{dm_{st}}{dt} = -\dot{m}_{out} = -\dot{m}_{evap} \quad \frac{dE_{st}}{dt} = \dot{E}_{in} - \dot{E}_{out} = q_{conv} + q_{rad} - q_{evap} \quad (1a,b)$$

With  $h_f$  as the enthalpy of liquid oxygen and  $h_g$  as the enthalpy of oxygen vapor, we have

$$E_{st} = m_{st} h_f \quad q_{evap} = \dot{m}_{out} h_g \quad (2a,b)$$

Combining Equations (1a) and (2a,b), Equation (1b) becomes (with  $h_{fg} = h_g - h_f$ )

$$\dot{m}_{out} h_{fg} = q_{conv} + q_{rad}$$

$$\dot{m}_{evap} = (q_{conv} + q_{rad}) / h_{fg} = \left[ h(T_{\infty} - T_s) + \varepsilon \sigma (T_{sur}^4 - T_s^4) \right] \pi D^2 / h_{fg} \quad (3)$$

$$\dot{m}_{evap} = \frac{\left[ 10 \text{ W/m}^2 \cdot \text{K} (298 - 263) \text{ K} + 0.2 \times 5.67 \times 10^{-8} \text{ W/m}^2 \cdot \text{K}^4 (298^4 - 263^4) \text{ K}^4 \right] \pi (0.5 \text{ m})^2}{214 \text{ kJ/kg}}$$

$$\dot{m}_{evap} = (350 + 35.2) \text{ W/m}^2 (0.785 \text{ m}^2) / 214 \text{ kJ/kg} = 1.41 \times 10^{-3} \text{ kg/s} \quad \leftarrow$$

(b) Using Equation (3), the mass rate of vapor production can be determined for the range of emissivity 0.2 to 0.94. The effect of increasing emissivity is to increase the heat rate into the container and, hence, increase the vapor production rate.

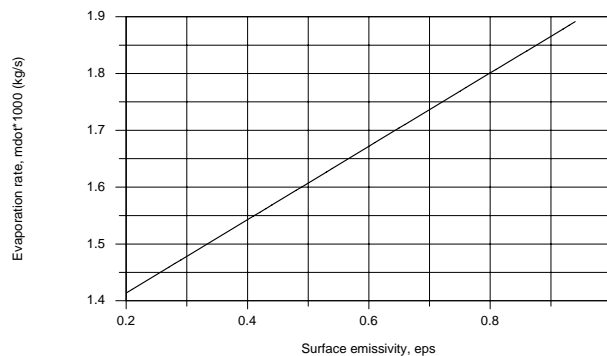

**COMMENTS:** To reduce the loss of oxygen due to vapor production, insulation should be applied to the outer surface of the container, in order to reduce  $q_{conv}$  and  $q_{rad}$ . Note from the calculations in part (a), that heat transfer by convection is greater than by radiation exchange.

### PROBLEM 1.50

**KNOWN:** Emissivity and solar absorptivity of steel sheet. Solar irradiation, air temperature and convection coefficient.

**FIND:** Temperature of the steel sheet to determine cat comfort.

**SCHEMATIC:**

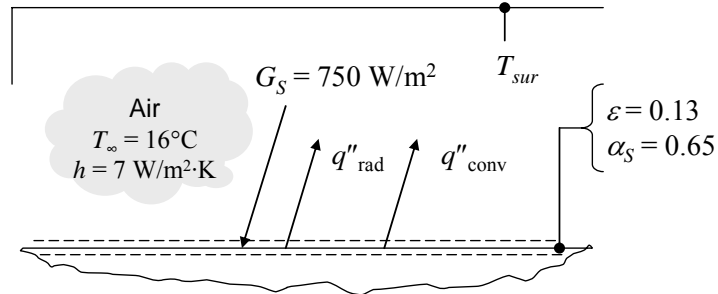

**ASSUMPTIONS:** (1) Steady-state conditions, (2) Bottom surface of steel is insulated, (3) Radiation from the environment can be treated as radiation from large surroundings, with  $\alpha = \epsilon$ , (4)  $T_{sur} = T_{\infty}$ .

**ANALYSIS:** Performing a control surface energy balance on the top surface of the steel sheet gives (on a per unit area basis)

$$\alpha_s G_S - q''_{rad} - q''_{conv} = 0$$

$$\alpha_s G_S - \epsilon \sigma (T_s^4 - T_{sur}^4) - h(T_s - T_{\infty}) = 0$$

$$0.65 \times 750 \text{ W/m}^2 - 0.13 \times 5.67 \times 10^{-8} \text{ W/m}^2 \cdot \text{K}^4 (T_s^4 - (289 \text{ K})^4) - 7 \text{ W/m}^2 \cdot \text{K} (T_s - 289 \text{ K}) = 0$$

$$2562 \text{ W/m}^2 - 7.37 \times 10^{-9} \text{ W/m}^2 \cdot \text{K}^4 T_s^4 - 7 \text{ W/m}^2 \cdot \text{K} T_s = 0$$

Solving this equation for  $T_s$  using IHT or other software results in  $T_s = 350 \text{ K} = 77^\circ\text{C}$ . A temperature of  $60^\circ\text{C}$  is typically safe to touch without being burned. The steel sheet would be uncomfortably hot or even cause burning. <

**COMMENTS:** The individual heat flux terms are

$$\alpha_s G_s = 488 \text{ W/m}^2$$

$$q''_{rad} = \epsilon \sigma (T_s^4 - T_{sur}^4) = 59 \text{ W/m}^2$$

$$q''_{conv} = h(T_s - T_{\infty}) = 428 \text{ W/m}^2$$

None of these is negligible, although the radiation exchange with the surroundings is smaller than the solar radiation and convection terms.

## PROBLEM 1.51

**KNOWN:** Initial temperature of water and tank volume. Power dissipation, emissivity, length and diameter of submerged heaters. Expressions for convection coefficient associated with natural convection in water and air.

**FIND:** (a) Time to raise temperature of water to prescribed value, (b) Heater temperature shortly after activation and at conclusion of process, (c) Heater temperature if activated in air.

**SCHEMATIC:**

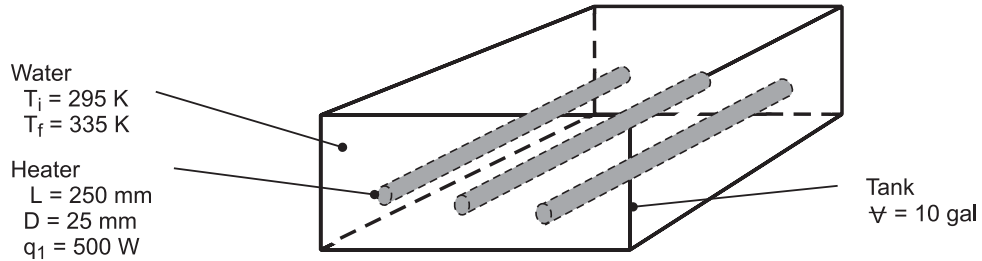

**ASSUMPTIONS:** (1) Negligible heat loss from tank to surroundings, (2) Water is *well-mixed* (at a uniform, but time varying temperature) during heating, (3) Negligible changes in thermal energy storage for heaters, (4) Constant properties, (5) Surroundings afforded by tank wall are large relative to heaters.

**ANALYSIS:** (a) Application of conservation of energy to a closed system (the water) at an instant, Equation (1.12c), with

$$\dot{E}_{st} = dU_t/dt, \quad \dot{E}_{in} = 3q_1, \quad \dot{E}_{out} = 0, \quad \text{and} \quad \dot{E}_g = 0,$$

$$\text{yields} \quad \frac{dU_t}{dt} = 3q_1 \quad \text{and} \quad \rho \forall c \frac{dT}{dt} = 3q_1$$

$$\text{Hence,} \quad \int_0^t dt = (\rho \forall c / 3q_1) \int_{T_i}^{T_f} dT$$

$$t = \frac{990 \text{ kg/m}^3 \times 10 \text{ gal} \left( 3.79 \times 10^{-3} \text{ m}^3 / \text{gal} \right) 4180 \text{ J/kg} \cdot \text{K}}{3 \times 500 \text{ W}} (335 - 295) \text{ K} = 4180 \text{ s} \quad <$$

(b) From Equation (1.3a), the heat rate by convection from each heater is

$$q_1 = Aq_1'' = Ah(T_s - T) = (\pi DL) 370(T_s - T)^{4/3}$$

$$\text{Hence,} \quad T_s = T + \left( \frac{q_1}{370\pi DL} \right)^{3/4} = T + \left( \frac{500 \text{ W}}{370 \text{ W/m}^2 \cdot \text{K}^{4/3} \times \pi \times 0.025 \text{ m} \times 0.250 \text{ m}} \right)^{3/4} = (T + 24) \text{ K}$$

With water temperatures of  $T_i \approx 295 \text{ K}$  and  $T_f = 335 \text{ K}$  shortly after the start of heating and at the end of heating, respectively,  $T_{s,i} = 319 \text{ K}$  and  $T_{s,f} = 359 \text{ K}$  <

(c) From Equation (1.10), the heat rate in air is

$$q_1 = \pi DL \left[ 0.70(T_s - T_\infty)^{4/3} + \varepsilon \sigma (T_s^4 - T_{sur}^4) \right]$$

Substituting the prescribed values of  $q_1$ ,  $D$ ,  $L$ ,  $T_\infty = T_{sur}$  and  $\varepsilon$ , an iterative solution yields

$$T_s = 830 \text{ K} \quad <$$

**COMMENTS:** In part (c) it is presumed that the heater can be operated at  $T_s = 830 \text{ K}$  without experiencing burnout. The much larger value of  $T_s$  for air is due to the smaller convection coefficient. However, with  $q_{conv}$  and  $q_{rad}$  equal to  $59 \text{ W}$  and  $441 \text{ W}$ , respectively, a significant portion of the heat dissipation is effected by radiation.

## PROBLEM 1.52

**KNOWN:** Power consumption, diameter, and inlet and discharge temperatures of a hair dryer.

**FIND:** (a) Volumetric flow rate and discharge velocity of heated air, (b) Heat loss from case.

**SCHEMATIC:**

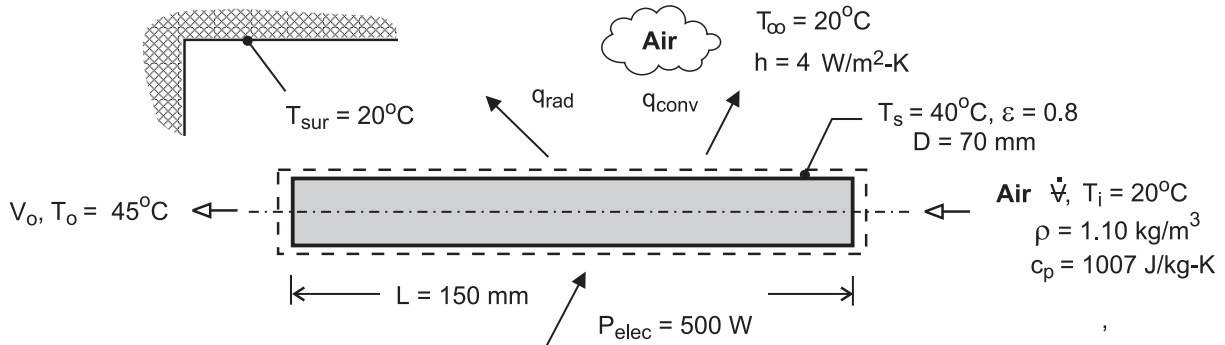

**ASSUMPTIONS:** (1) Steady-state, (2) Constant air properties, (3) Negligible potential and kinetic energy changes of air flow, (4) Negligible work done by fan, (5) Negligible heat transfer from casing of dryer to ambient air (Part (a)), (6) Radiation exchange between a small surface and a large enclosure (Part (b)).

**ANALYSIS:** (a) For a control surface about the air flow passage through the dryer, conservation of energy for an open system reduces to

$$\dot{m}(u + pv)_i - \dot{m}(u + pv)_o + q = 0$$

where  $u + pv = i$  and  $q = P_{\text{elec}}$ . Hence, with  $\dot{m}(i_i - i_o) = \dot{m}c_p(T_i - T_o)$ ,

$$\dot{m}c_p(T_o - T_i) = P_{\text{elec}}$$

$$\dot{m} = \frac{P_{\text{elec}}}{c_p(T_o - T_i)} = \frac{500 \text{ W}}{1007 \text{ J/kg} \cdot \text{K}(25^\circ\text{C})} = 0.0199 \text{ kg/s}$$

$$\dot{V} = \frac{\dot{m}}{\rho} = \frac{0.0199 \text{ kg/s}}{1.10 \text{ kg/m}^3} = 0.0181 \text{ m}^3/\text{s} \quad <$$

$$V_o = \frac{\dot{V}}{A_c} = \frac{4\dot{V}}{\pi D^2} = \frac{4 \times 0.0181 \text{ m}^3/\text{s}}{\pi(0.07 \text{ m})^2} = 4.7 \text{ m/s} \quad <$$

(b) Heat transfer from the casing is by convection and radiation, and from Equation (1.10)

$$q = hA_s(T_s - T_\infty) + \varepsilon A_s \sigma (T_s^4 - T_{\text{sur}}^4)$$

where  $A_s = \pi DL = \pi(0.07 \text{ m} \times 0.15 \text{ m}) = 0.033 \text{ m}^2$ . Hence,

$$q = 4 \text{ W/m}^2 \cdot \text{K}(0.033 \text{ m}^2)(20^\circ\text{C}) + 0.8 \times 0.033 \text{ m}^2 \times 5.67 \times 10^{-8} \text{ W/m}^2 \cdot \text{K}^4 (313^4 - 293^4) \text{ K}^4$$

$$q = 2.64 \text{ W} + 3.33 \text{ W} = 5.97 \text{ W} \quad <$$

The heat loss is much less than the electrical power, and the assumption of negligible heat loss is justified.

**COMMENTS:** Although the mass flow rate is invariant, the volumetric flow rate increases because the air is heated in its passage through the dryer, causing a reduction in the density. However, for the prescribed temperature rise, the change in  $\rho$ , and hence the effect on  $\dot{V}$ , is small.



## PROBLEM 1.54

**KNOWN:** Temperatures of small cake as well as oven air and walls. Convection heat transfer coefficient under free and forced convection conditions. Emissivity of cake batter and pan.

**FIND:** Heat flux to cake under free and forced convection conditions.

**SCHEMATIC:**

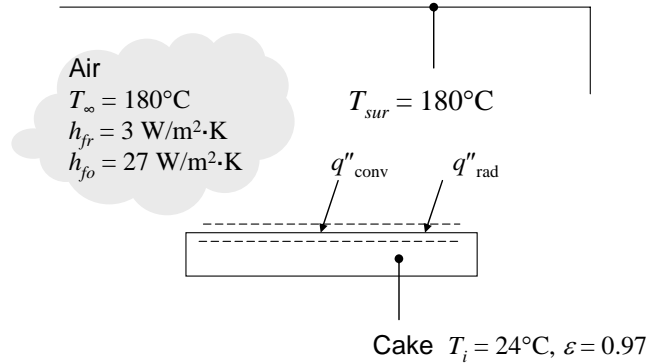

**ASSUMPTIONS:** (1) Large surroundings.

**ANALYSIS:** The heat flux to the cake pan and batter is due to convection and radiation. With the surface temperature equal to  $T_i$ , when the convection feature is disabled,

$$\begin{aligned}
 q''_{fr} &= (q''_{conv} + q''_{rad}) = h_{fr}(T_{\infty} - T_i) + \varepsilon\sigma(T_{sur}^4 - T_i^4) \\
 &= 3 \text{ W/m}^2 \cdot \text{K}(180^{\circ}\text{C} - 24^{\circ}\text{C}) + 0.97 \times 5.67 \times 10^{-8} \text{ W/m}^2 \cdot \text{K}^4 \left( (180 + 273 \text{ K})^4 - (24 + 273 \text{ K})^4 \right) < \\
 &= 470 \text{ W/m}^2 + 1890 \text{ W/m}^2 = 2360 \text{ W/m}^2
 \end{aligned}$$

When the convection feature is activated, the heat flux is

$$\begin{aligned}
 q''_{fo} &= (q''_{conv} + q''_{rad}) = h_{fo}(T_{\infty} - T_i) + \varepsilon\sigma(T_{sur}^4 - T_i^4) \\
 &= 27 \text{ W/m}^2 \cdot \text{K}(180^{\circ}\text{C} - 24^{\circ}\text{C}) + 0.97 \times 5.67 \times 10^{-8} \text{ W/m}^2 \cdot \text{K}^4 \left( (180 + 273 \text{ K})^4 - (24 + 273 \text{ K})^4 \right) < \\
 &= 4210 \text{ W/m}^2 + 1890 \text{ W/m}^2 = 6100 \text{ W/m}^2
 \end{aligned}$$

**COMMENTS:** Under free convection conditions, the convection contribution is about 20% of the total heat flux. When forced convection is activated, convection becomes larger than radiation, accounting for 69% of the total heat flux. The cake will bake faster under forced convection conditions.



## PROBLEM 1.55

**KNOWN:** Hot plate-type wafer thermal processing tool based upon heat transfer modes by conduction through gas within the gap and by radiation exchange across gap.

**FIND:** (a) Radiative and conduction heat fluxes across gap for specified hot plate and wafer temperatures and gap separation; initial time rate of change in wafer temperature for each mode, and (b) heat fluxes and initial temperature-time change for gap separations of 0.2, 0.5 and 1.0 mm for hot plate temperatures  $300 < T_h < 1300^\circ\text{C}$ . Comment on the relative importance of the modes and the influence of the gap distance. Under what conditions could a wafer be heated to  $900^\circ\text{C}$  in less than 10 seconds?

**SCHEMATIC:**

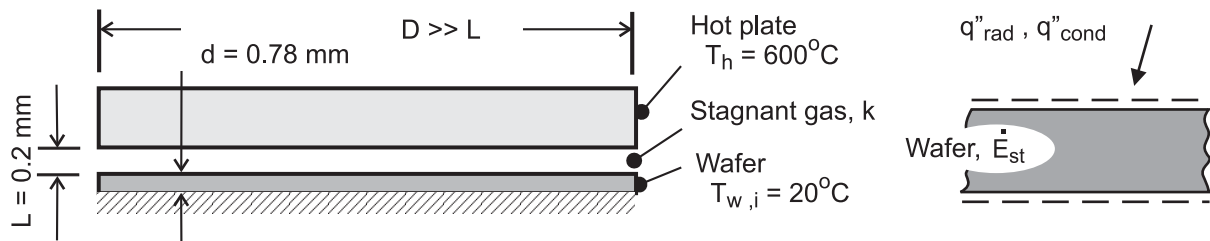

**ASSUMPTIONS:** (1) Steady-state conditions for flux calculations, (2) Diameter of hot plate and wafer much larger than gap spacing, approximating plane, infinite planes, (3) One-dimensional conduction through gas, (4) Hot plate and wafer are blackbodies, (5) Negligible heat losses from wafer backside, and (6) Wafer temperature is uniform at the onset of heating.

**PROPERTIES:** Wafer:  $\rho = 2700 \text{ kg/m}^3$ ,  $c = 875 \text{ J/kg}\cdot\text{K}$ ; Gas in gap:  $k = 0.0436 \text{ W/m}\cdot\text{K}$ .

**ANALYSIS:** (a) The radiative heat flux between the hot plate and wafer for  $T_h = 600^\circ\text{C}$  and  $T_w = 20^\circ\text{C}$  follows from the rate equation,

$$q''_{\text{rad}} = \sigma (T_h^4 - T_w^4) = 5.67 \times 10^{-8} \text{ W/m}^2 \cdot \text{K}^4 \left( (600 + 273)^4 - (20 + 273)^4 \right) \text{K}^4 = 32.5 \text{ kW/m}^2 <$$

The conduction heat flux through the gas in the gap with  $L = 0.2 \text{ mm}$  follows from Fourier's law,

$$q''_{\text{cond}} = k \frac{T_h - T_w}{L} = 0.0436 \text{ W/m}\cdot\text{K} \frac{(600 - 20) \text{ K}}{0.0002 \text{ m}} = 126 \text{ kW/m}^2 <$$

The initial time rate of change of the wafer can be determined from an energy balance on the wafer at the instant of time the heating process begins,

$$\dot{E}''_{\text{in}} - \dot{E}''_{\text{out}} = \dot{E}''_{\text{st}} \quad \dot{E}''_{\text{st}} = \rho c d \left( \frac{dT_w}{dt} \right)_i$$

where  $\dot{E}''_{\text{out}} = 0$  and  $\dot{E}''_{\text{in}} = q''_{\text{rad}}$  or  $q''_{\text{cond}}$ . Substituting numerical values, find

$$\left. \frac{dT_w}{dt} \right)_{i,\text{rad}} = \frac{q''_{\text{rad}}}{\rho c d} = \frac{32.5 \times 10^3 \text{ W/m}^2}{2700 \text{ kg/m}^3 \times 875 \text{ J/kg}\cdot\text{K} \times 0.00078 \text{ m}} = 17.6 \text{ K/s} <$$

$$\left. \frac{dT_w}{dt} \right)_{i,\text{cond}} = \frac{q''_{\text{cond}}}{\rho c d} = 68.6 \text{ K/s} <$$

Continued .....

## PROBLEM 1.55 (Cont.)

(b) Using the foregoing equations, the heat fluxes and initial rate of temperature change for each mode can be calculated for selected gap separations  $L$  and range of hot plate temperatures  $T_h$  with  $T_w = 20^\circ\text{C}$ .

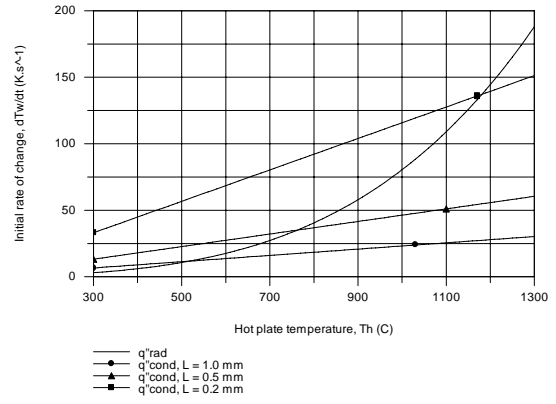
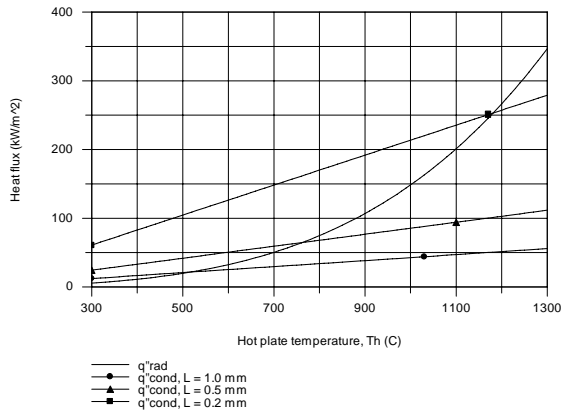

In the left-hand graph, the conduction heat flux increases linearly with  $T_h$  and inversely with  $L$  as expected. The radiative heat flux is independent of  $L$  and highly non-linear with  $T_h$ , but does not approach that for the highest conduction heat rate until  $T_h$  approaches  $1200^\circ\text{C}$ .

The general trends for the initial temperature-time change,  $(dT_w/dt)_i$ , follow those for the heat fluxes. To reach  $900^\circ\text{C}$  in 10 s requires an average temperature-time change rate of 90 K/s. Recognizing that  $(dT_w/dt)$  will decrease with increasing  $T_w$ , this rate could be met only with a very high  $T_h$  and the smallest  $L$ .

## PROBLEM 1.56

**KNOWN:** Silicon wafer, radiantly heated by lamps, experiencing an annealing process with known backside temperature.

**FIND:** Whether temperature difference across the wafer thickness is less than  $2^\circ\text{C}$  in order to avoid damaging the wafer.

**SCHEMATIC:**

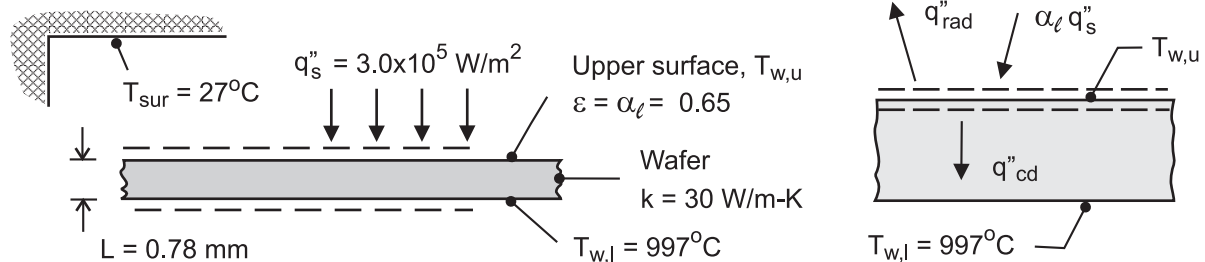

**ASSUMPTIONS:** (1) Steady-state conditions, (2) One-dimensional conduction in wafer, (3) Radiation exchange between upper surface of wafer and surroundings is between a small object and a large enclosure, and (4) Vacuum condition in chamber, no convection.

**PROPERTIES:** Wafer:  $k = 30 \text{ W/m}\cdot\text{K}$ ,  $\varepsilon = \alpha_\ell = 0.65$ .

**ANALYSIS:** Perform a surface energy balance on the upper surface of the wafer to determine  $T_{w,u}$ . The processes include the absorbed radiant flux from the lamps, radiation exchange with the chamber walls, and conduction through the wafer.

$$\dot{E}''_{\text{in}} - \dot{E}''_{\text{out}} = 0$$

$$\alpha_\ell q''_s - q''_{\text{rad}} - q''_{\text{cd}} = 0$$

$$\alpha_\ell q''_s - \varepsilon \sigma (T_{w,u}^4 - T_{\text{sur}}^4) - k \frac{T_{w,u} - T_{w,l}}{L} = 0$$

$$0.65 \times 3.0 \times 10^5 \text{ W/m}^2 - 0.65 \times 5.67 \times 10^{-8} \text{ W/m}^2 \cdot \text{K}^4 (T_{w,u}^4 - (27 + 273)^4) - 30 \text{ W/m}\cdot\text{K} [T_{w,u} - (997 + 273)] \text{ K} / 0.00078 \text{ m} = 0$$

$$T_{w,u} = 1273 \text{ K} = 1000^\circ\text{C} \quad \leftarrow$$

**COMMENTS:** (1) The temperature difference for this steady-state operating condition,  $T_{w,u} - T_{w,l}$ , is larger than  $2^\circ\text{C}$ . Warping of the wafer and inducing slip planes in the crystal structure could occur.

(2) The radiation exchange rate equation requires that temperature must be expressed in kelvin units. Why is it permissible to use kelvin or Celsius temperature units in the conduction rate equation?

(3) Note how the surface energy balance, Eq. 1.13, is represented schematically. It is essential to show the control surfaces, and then identify the rate processes associated with the surfaces. Make sure the directions (in or out) of the process are consistent with the energy balance equation.

## PROBLEM 1.57

**KNOWN:** Silicon wafer positioned in furnace with top and bottom surfaces exposed to hot and cool zones, respectively.

**FIND:** (a) Initial rate of change of the wafer temperature corresponding to the wafer temperature  $T_{w,i} = 300\text{ K}$ , and (b) Steady-state temperature reached if the wafer remains in this position. How significant is convection for this situation? Sketch how you'd expect the wafer temperature to vary as a function of vertical distance.

**SCHEMATIC:**

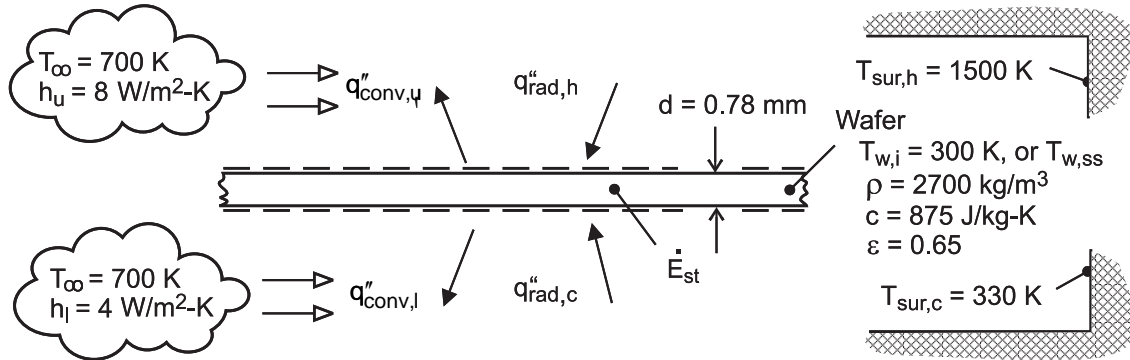

**ASSUMPTIONS:** (1) Wafer temperature is uniform, (2) Transient conditions when wafer is initially positioned, (3) Hot and cool zones have uniform temperatures, (3) Radiation exchange is between small surface (wafer) and large enclosure (chamber, hot or cold zone), and (4) Negligible heat losses from wafer to mounting pin holder.

**ANALYSIS:** The energy balance on the wafer illustrated in the schematic above includes convection from the upper (u) and lower (l) surfaces with the ambient gas, radiation exchange with the hot- and cool-zone (chamber) surroundings, and the rate of energy storage term for the transient condition.

$$\dot{E}_{in}'' - \dot{E}_{out}'' = \dot{E}_{st}''$$

$$q_{rad,h}'' + q_{rad,c}'' - q_{conv,u}'' - q_{conv,l}'' = \rho c d \frac{dT_w}{dt}$$

$$\epsilon \sigma (T_{sur,h}^4 - T_w^4) + \epsilon \sigma (T_{sur,c}^4 - T_w^4) - h_u (T_w - T_\infty) - h_l (T_w - T_\infty) = \rho c d \frac{dT_w}{dt}$$

(a) For the initial condition, the time rate of temperature change of the wafer is determined using the energy balance above with  $T_w = T_{w,i} = 300\text{ K}$ ,

$$0.65 \times 5.67 \times 10^{-8} \text{ W/m}^2 \cdot \text{K}^4 (1500^4 - 300^4) \text{ K}^4 + 0.65 \times 5.67 \times 10^{-8} \text{ W/m}^2 \cdot \text{K}^4 (330^4 - 300^4) \text{ K}^4$$

$$-8 \text{ W/m}^2 \cdot \text{K} (300 - 700) \text{ K} - 4 \text{ W/m}^2 \cdot \text{K} (300 - 700) \text{ K} =$$

$$2700 \text{ kg/m}^3 \times 875 \text{ J/kg} \cdot \text{K} \times 0.00078 \text{ m} (dT_w / dt)_i$$

$$(dT_w / dt)_i = 104 \text{ K/s}$$

<

(b) For the steady-state condition, the energy storage term is zero, and the energy balance can be solved for the steady-state wafer temperature,  $T_w = T_{w,ss}$ .

Continued .....

### PROBLEM 1.57 (Cont.)

$$0.65\sigma(1500^4 - T_{w,ss}^4)K^4 + 0.65\sigma(330^4 - T_{w,ss}^4)K^4$$

$$-8W/m^2 \cdot K(T_{w,ss} - 700)K - 4W/m^2 \cdot K(T_{w,ss} - 700)K = 0$$

$$T_{w,ss} = 1251 \text{ K}$$

<

To determine the relative importance of the convection processes, re-solve the energy balance above ignoring those processes to find  $(dT_w/dt)_i = 101 \text{ K/s}$  and  $T_{w,ss} = 1262 \text{ K}$ . We conclude that the radiation exchange processes control the initial time rate of temperature change and the steady-state temperature.

If the wafer were elevated above the present operating position, its temperature would increase, since the lower surface would begin to experience radiant exchange with progressively more of the hot zone chamber. Conversely, by lowering the wafer, the upper surface would experience less radiant exchange with the hot zone chamber, and its temperature would decrease. The temperature-distance trend might appear as shown in the sketch.

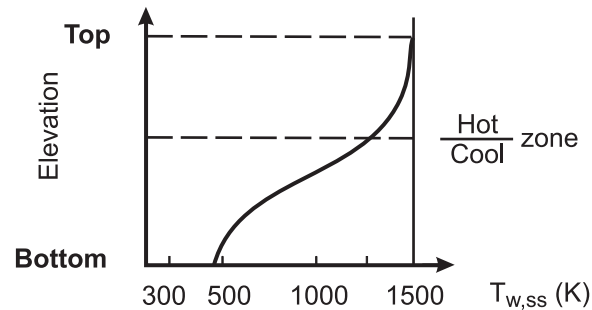

### PROBLEM 1.58

**KNOWN:** Electrolytic membrane dimensions, bipolar plate thicknesses, desired operating temperature and surroundings as well as air temperatures.

**FIND:** (a) Electrical power produced by stack that is 200 mm in length for bipolar plate thicknesses  $1 \text{ mm} < t_{bp} < 10 \text{ mm}$ , (b) Surface temperature of stack for various bipolar plate thicknesses, (c) Identify strategies to promote uniform temperature, identify effect of various air and surroundings temperatures, identify membrane most likely to fail.

**SCHEMATIC:**

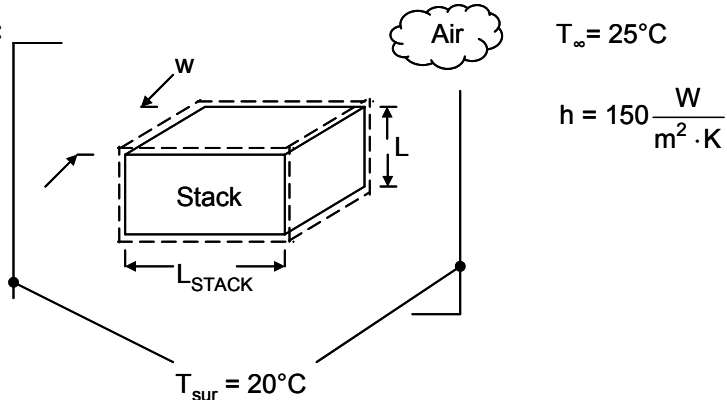

**ASSUMPTIONS:** (1) Steady-state conditions, (2) Large surroundings, (3) Surface emissivity and absorptivity are the same, (4) Negligible energy entering or leaving the control volume due to gas or liquid flows, (5) Negligible energy loss or gain from or to the stack by conduction.

**ANALYSIS:** The length of the fuel cell is related to the number of membranes and the thickness of the membranes and bipolar plates as follows.

$$L_{\text{stack}} = N \times t_m + (N + 1) \times t_{bp} = N \times (t_m + t_{bp}) + t_{bp}$$

For  $t_{bp} = 1 \text{ mm}$ ,  $200 \times 10^{-3} \text{ m} = N \times (0.43 \times 10^{-3} \text{ m} + 1.0 \times 10^{-3} \text{ m}) + 1.0 \times 10^{-3} \text{ m}$   
or  $N = 139$

For  $t_{bp} = 10 \text{ mm}$ ,  $200 \times 10^{-3} \text{ m} = N \times (0.43 \times 10^{-3} \text{ m} + 10 \times 10^{-3} \text{ m}) + 10 \times 10^{-3} \text{ m}$   
or  $N = 18$

(a) For  $t_{bp} = 1 \text{ mm}$ , the electrical power produced by the stack is

$$P = E_{\text{STACK}} \times I = N \times E_c \times I = 139 \times 0.6 \text{ V} \times 60 \text{ A} = 5000 \text{ W} = 5 \text{ kW} \quad <$$

and the thermal energy produced by the stack is

$$\dot{E}_g = N \times \dot{E}_{c,g} = 139 \times 45 \text{ W} = 6,255 \text{ W} = 6.26 \text{ kW} \quad <$$

Continued...

### PROBLEM 1.58 (Cont.)

Proceeding as before for  $t_{bp} = 10 \text{ mm}$ , we find  $P = 648 \text{ W} = 0.65 \text{ kW}$ ;  $\dot{E}_g = 810 \text{ W} = 0.81 \text{ kW} <$

(b) An energy balance on the control volume yields

$$\dot{E}_g - \dot{E}_{out} = 0 \quad \text{or} \quad \dot{E}_g - A(q''_{conv} + q''_{rad}) = 0 \quad (1)$$

Substituting Eqs. 1.3a and 1.7 into Eq. (1) yields

$$\dot{E}_g - A[h(T_s - T_\infty) + \epsilon\sigma(T_s^4 - T_{sur}^4)] = 0$$

where  $A = 4 \times L \times w + 2 \times H \times w$

$$= 4 \times 200 \times 10^{-3} \text{ m} \times 100 \times 10^{-3} \text{ m} + 2 \times 100 \times 10^{-3} \text{ m} \times 100 \times 10^{-3} \text{ m} = 0.1 \text{ m}^2$$

For  $t_{bp} = 1 \text{ mm}$  and  $\dot{E}_g = 6255 \text{ W}$ ,

$$6255 \text{ W} - 0.1 \text{ m}^2 \times \left[ 150 \frac{\text{W}}{\text{m}^2 \cdot \text{K}} \times (T_s - 298) \text{ K} + 0.88 \times 5.67 \times 10^{-8} \frac{\text{W}}{\text{m}^2 \cdot \text{K}^4} \times (T_s^4 - T_{sur}^4) \text{ K}^4 \right] = 0$$

The preceding equation may be solved to yield

$$T_s = 656 \text{ K} = 383^\circ\text{C}$$

Therefore, for  $t_{bp} = 1 \text{ mm}$  the surface temperature exceeds the maximum allowable operating temperature and the stack must be cooled. <

For  $t_{bp} = 10 \text{ mm}$  and  $\dot{E}_g = 810 \text{ W}$ ,  $T_s = 344 \text{ K} = 71^\circ\text{C}$  and the stack may need to be heated to operate at  $T = 80^\circ\text{C}$ . <

(c) To decrease the stack temperature, the emissivity of the surface may be increased, the bipolar plates may be made larger than  $100 \text{ mm} \times 100 \text{ mm}$  to act as *cooling fins*, internal channels might be machined in the bipolar plates to carry a pumped coolant, and the convection coefficient may be increased by using forced convection from a fan. The stack temperature can be increased by insulating the external surfaces of the stack.

Uniform internal temperatures may be promoted by using materials of high thermal conductivity. The operating temperature of the stack will shift upward as either the surroundings or ambient temperature increases. The membrane that experiences the highest temperature will be most likely to fail. Unfortunately, the highest temperatures are likely to exist near the center of the stack, making stack repair difficult and expensive. <

**COMMENTS:** (1) There is a tradeoff between the power produced by the stack, and the operating temperature of the stack. (2) Manufacture of the bipolar plates becomes difficult, and cooling channels are difficult to incorporate into the design, as the bipolar plates become thinner. (3) If one membrane fails, the entire stack fails since the membranes are connected in series electrically.

## PROBLEM 1.59

**KNOWN:** Total rate of heat transfer leaving nacelle (from Example 1.3). Dimensions and emissivity of the nacelle, ambient and surrounding temperatures, convection heat transfer coefficient exterior to nacelle. Temperature of exiting forced air flow.

**FIND:** Required mass flow rate of forced air flow.

**SCHEMATIC:**

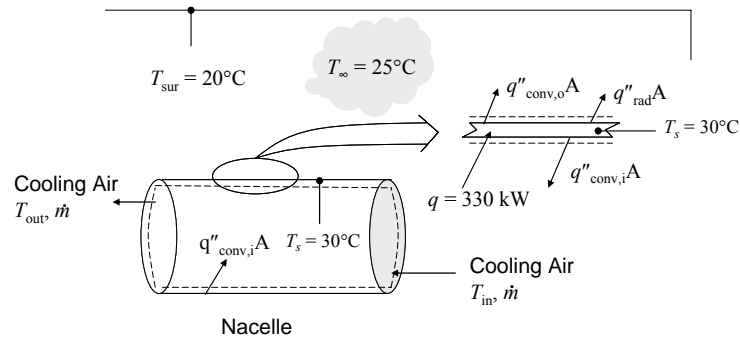

**ASSUMPTIONS:** (1) Steady-state conditions, (2) Large surroundings, (3) Surface of the nacelle that is adjacent to the hub is adiabatic, (4) Forced air exits nacelle at the nacelle surface temperature.

**ANALYSIS:** The total rate of heat transfer leaving the nacelle is known from Example 1.3 to be  $q = 0.33 \times 10^6 \text{ W} = 330 \text{ kW}$ . Heat is removed from the nacelle by radiation and convection from the exterior surface of the nacelle ( $q_{\text{rad}}$  and  $q_{\text{conv,o}}$ , respectively), and by convection from the interior surface to the forced flow of air through the nacelle ( $q_{\text{conv,i}}$ ). An energy balance on the nacelle based upon the upper-right part of the schematic yields

$$q = q_{\text{rad}} + q_{\text{conv,o}} + q_{\text{conv,i}} = A[q_{\text{rad}} + q_{\text{conv,o}}] + q_{\text{conv,i}}$$

Thus the required rate of heat removal by the forced air is given by

$$q_{\text{conv,i}} = q - A[q_{\text{rad}} + q_{\text{conv,o}}] = q - \left[ \pi DL + \frac{\pi D^2}{4} \right] \left[ \varepsilon \sigma (T_s^4 - T_{\text{sur}}^4) + h(T_s - T_\infty) \right]$$

In order to maintain a nacelle surface temperature of  $T_s = 30^\circ\text{C}$ , the required  $q_{\text{conv,i}}$  is

$$\begin{aligned} q_{\text{conv,i}} &= 330 \text{ kW} - \left[ \pi \times 3 \text{ m} \times 6 \text{ m} + \frac{\pi \times (3 \text{ m})^2}{4} \right] \times \\ &\quad \left[ 0.83 \times 5.67 \times 10^{-8} \text{ W/m}^2 \cdot \text{K}^4 \left( (273 + 30)^4 - (273 + 20)^4 \right) \text{K}^4 + 35 \text{ W/m}^2 \cdot \text{K} (30 - 25) \text{K} \right] \\ &= 330 \text{ kW} - (3 \text{ kW} + 11 \text{ kW}) = 316 \text{ kW} \end{aligned}$$

The required mass flow rate of air can be found by applying an energy balance to the air flowing through the nacelle, as shown by the control volume on the lower left of the schematic. From Equation 1.12e:

$$\dot{m} = \frac{q_{\text{conv,i}}}{c_p(T_{\text{out}} - T_{\text{in}})} = \frac{q_{\text{conv,i}}}{c_p(T_s - T_\infty)} = \frac{316 \text{ kW}}{1007 \text{ J/kg} \cdot \text{K} (30 - 25) \text{K}} = 63 \text{ kg/s} \quad <$$

Continued...



### PROBLEM 1.59 (Cont.)

**COMMENTS:** (1) With the surface temperature lowered to 30°C, the heat lost by radiation and convection from the exterior surface of the nacelle is small, and most of the heat must be removed by convection to the interior forced air flow. (2) The air mass flow rate corresponds to a velocity of around  $V = \dot{m} / \rho A_c = \dot{m} / (\rho \pi D^2 / 4) = 7$  m/s, using an air density of 1.1 kg/m<sup>3</sup> and assuming that the air flows through the entire nacelle cross-sectional area. This would lead to uncomfortable working conditions unless the forced air flow were segregated from the working space. (3) The required heat transfer coefficient on the interior surface can be estimated as  $h_i = q_{\text{conv},i} / (\pi DL(T_s - T_\infty)) = 1100$  W/m<sup>2</sup>·K. In Chapter 8, you will learn whether this heat transfer coefficient can be achieved under the given conditions.

## PROBLEM 1.60

**KNOWN:** Rod of prescribed diameter experiencing electrical dissipation from passage of electrical current and convection under different air velocity conditions. See Example 1.4.

**FIND:** Rod temperature as a function of the electrical current for  $0 \leq I \leq 10$  A with convection coefficients of 50, 100 and 250  $\text{W/m}^2\cdot\text{K}$ . Will variations in the surface emissivity have a significant effect on the rod temperature?

**SCHEMATIC:**

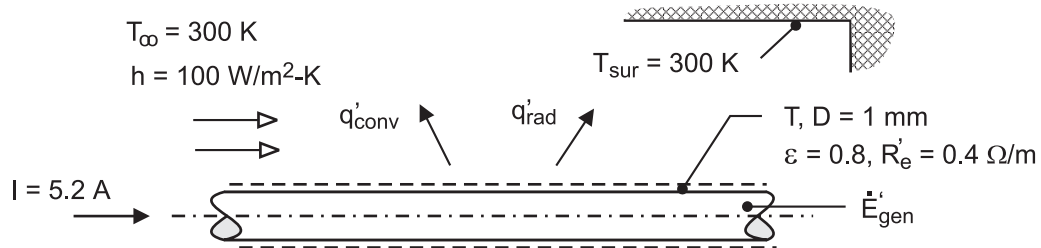

**ASSUMPTIONS:** (1) Steady-state conditions, (2) Uniform rod temperature, (3) Radiation exchange between the outer surface of the rod and the surroundings is between a small surface and large enclosure.

**ANALYSIS:** The energy balance on the rod for steady-state conditions has the form,

$$q'_{\text{conv}} + q'_{\text{rad}} = \dot{E}'_{\text{gen}}$$

$$\pi D h (T - T_\infty) + \pi D \epsilon \sigma (T^4 - T_{\text{sur}}^4) = I^2 R'_e$$

Using this equation in the Workspace of IHT, the rod temperature is calculated and plotted as a function of current for selected convection coefficients.

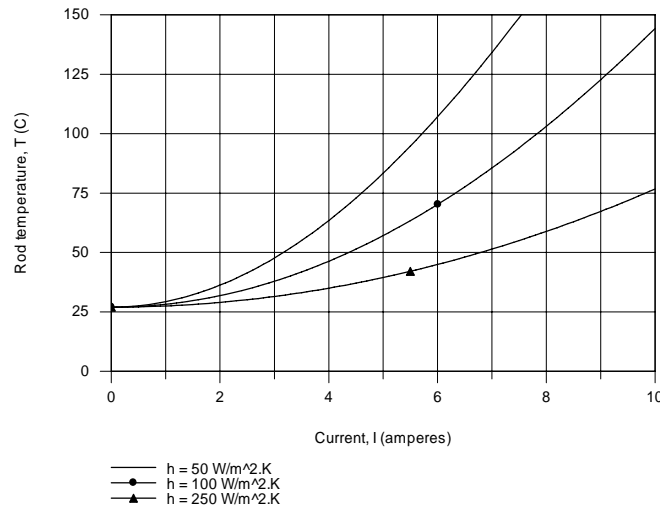

**COMMENTS:** (1) For forced convection over the cylinder, the convection heat transfer coefficient is dependent upon air velocity approximately as  $h \sim V^{0.6}$ . Hence, to achieve a 5-fold change in the convection coefficient (from 50 to 250  $\text{W/m}^2\cdot\text{K}$ ), the air velocity must be changed by a factor of nearly 15.

Continued .....

### PROBLEM 1.60 (Cont.)

(2) For the condition of  $I = 4 \text{ A}$  with  $h = 50 \text{ W/m}^2 \cdot \text{K}$  with  $T = 63.5^\circ\text{C}$ , the convection and radiation exchange rates per unit length are, respectively,  $q'_{\text{conv}} = 5.7 \text{ W/m}$  and  $q'_{\text{rad}} = 0.67 \text{ W/m}$ . We conclude that convection is the dominant heat transfer mode and that changes in surface emissivity could have only a minor effect. Will this also be the case if  $h = 100$  or  $250 \text{ W/m}^2 \cdot \text{K}$ ?

(3) What would happen to the rod temperature if there was a “loss of coolant” condition where the air flow would cease?

(4) The Workspace for the IHT program to calculate the heat losses and perform the parametric analysis to generate the graph is shown below. It is good practice to provide commentary with the code making your solution logic clear, and to summarize the results. It is also good practice to show plots in *customary* units, that is, the units used to prescribe the problem. As such the graph of the rod temperature is shown above with Celsius units, even though the calculations require temperatures in kelvins.

**// Energy balance; from Ex. 1.4, Comment 1**

```
-q'cv - q'rad + Edot'g = 0
q'cv = pi*D*h*(T - Tinf)
q'rad = pi*D*eps*sigma*(T^4 - Tsur^4)
sigma = 5.67e-8
```

```
// The generation term has the form
Edot'g = I^2*R'e
qdot = I^2*R'e / (pi*D^2/4)
```

**// Input parameters**

```
D = 0.001
Tsur = 300
T_C = T - 273           // Representing temperature in Celsius units using _C subscript
eps = 0.8
Tinf = 300
h = 100
//h = 50                // Values of coefficient for parameter study
//h = 250
I = 5.2                 // For graph, sweep over range from 0 to 10 A
//I = 4                 // For evaluation of heat rates with h = 50 W/m^2.K
R'e = 0.4
```

**/\* Base case results:  $I = 5.2 \text{ A}$  with  $h = 100 \text{ W/m}^2 \cdot \text{K}$ , find  $T = 60 \text{ C}$  (Comment 2 case).**

Edot'g	T	T_C	q'cv	q'rad	qdot	D	I	R'e
	Tinf	Tsur	eps	h	sigma			
10.82	332.6	59.55	10.23	0.5886	1.377E7	0.001	5.2	0.4
	300	300	0.8	100	5.67E-8			

**/\* Results:  $I = 4 \text{ A}$  with  $h = 50 \text{ W/m}^2 \cdot \text{K}$ , find  $q'_{\text{cv}} = 5.7 \text{ W/m}$  and  $q'_{\text{rad}} = 0.67 \text{ W/m}$**

Edot'g	T	T_C	q'cv	q'rad	qdot	D	I	R'e
	Tinf	Tsur	eps	h	sigma			
6.4	336.5	63.47	5.728	0.6721	8.149E6	0.001	4	0.4
	300	300	0.8	50	5.67E-8			

## PROBLEM 1.61

**KNOWN:** Long bus bar of prescribed diameter and ambient air and surroundings temperatures. Relations for the electrical resistivity and free convection coefficient as a function of temperature.

**FIND:** (a) Current carrying capacity of the bus bar if its surface temperature is not to exceed 65°C; compare relative importance of convection and radiation exchange heat rates, and (b) Show graphically the operating temperature of the bus bar as a function of current for the range  $100 \leq I \leq 5000$  A for bus-bar diameters of 10, 20 and 40 mm. Plot the ratio of the heat transfer by convection to the total heat transfer for these conditions.

**SCHEMATIC:**

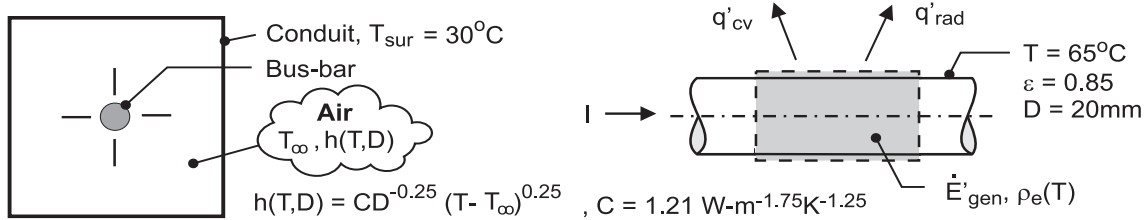

**ASSUMPTIONS:** (1) Steady-state conditions, (2) Bus bar and conduit are very long, (3) Uniform bus-bar temperature, (4) Radiation exchange between the outer surface of the bus bar and the conduit is between a small surface and a large enclosure.

**PROPERTIES:** Bus-bar material,  $\rho_e = \rho_{e,o} [1 + \alpha(T - T_o)]$ ,  $\rho_{e,o} = 0.0171 \mu\Omega \cdot m$ ,  $T_o = 25^\circ\text{C}$ ,  $\alpha = 0.00396 \text{ K}^{-1}$ .

**ANALYSIS:** An energy balance on the bus-bar for a unit length as shown in the schematic above has the form

$$\begin{aligned} \dot{E}'_{in} - \dot{E}'_{out} + \dot{E}'_{gen} &= 0 \\ -q'_{rad} - q'_{conv} + I^2 R'_e &= 0 \\ -\varepsilon \pi D \sigma (T^4 - T_{sur}^4) - h \pi D (T - T_\infty) + I^2 \rho_e / A_c &= 0 \end{aligned}$$

where  $R'_e = \rho_e / A_c$  and  $A_c = \pi D^2 / 4$ . Using the relations for  $\rho_e(T)$  and  $h(T,D)$ , and substituting numerical values with  $T = 65^\circ\text{C}$ , find

$$q'_{rad} = 0.85 \pi (0.020 \text{ m}) \times 5.67 \times 10^{-8} \text{ W/m}^2 \cdot \text{K}^4 \left( [65 + 273]^4 - [30 + 273]^4 \right) \text{ K}^4 = 14.0 \text{ W/m} \quad <$$

$$q'_{conv} = 7.83 \text{ W/m}^2 \cdot \text{K} \pi (0.020 \text{ m}) (65 - 30) \text{ K} = 17.2 \text{ W/m} \quad <$$

where  $h = 1.21 \text{ W} \cdot \text{m}^{-1.75} \cdot \text{K}^{-1.25} (0.020 \text{ m})^{-0.25} (65 - 30)^{0.25} = 7.83 \text{ W/m}^2 \cdot \text{K}$

$$I^2 R'_e = I^2 \left( 198.2 \times 10^{-6} \Omega \cdot \text{m} \right) / \pi (0.020)^2 \text{ m}^2 / 4 = 6.31 \times 10^{-5} I^2 \text{ W/m}$$

where  $\rho_e = 0.0171 \times 10^{-6} \Omega \cdot \text{m} \left[ 1 + 0.00396 \text{ K}^{-1} (65 - 25) \text{ K} \right] = 198.2 \mu\Omega \cdot \text{m}$

The maximum allowable current capacity and the ratio of the convection to total heat transfer rate are

$$I = 700 \text{ A} \quad q'_{cv} / (q'_{cv} + q'_{rad}) = q'_{cv} / q'_{tot} = 0.55 \quad <$$

For this operating condition, convection heat transfer is 55% of the total heat transfer.

(b) Using these equations in the Workspace of IHT, the bus-bar operating temperature is calculated and plotted as a function of the current for the range  $100 \leq I \leq 5000$  A for diameters of 10, 20 and 40 mm. Also shown below is the corresponding graph of the ratio (expressed in percentage units) of the heat transfer by convection to the total heat transfer,  $q'_{cv} / q'_{tot}$ .

Continued .....

### PROBLEM 1.61 (Cont.)

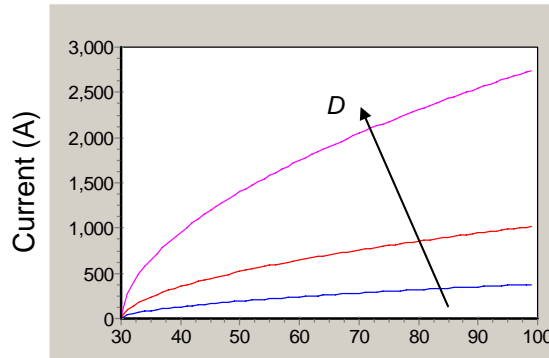

Bus bar temperature (C)

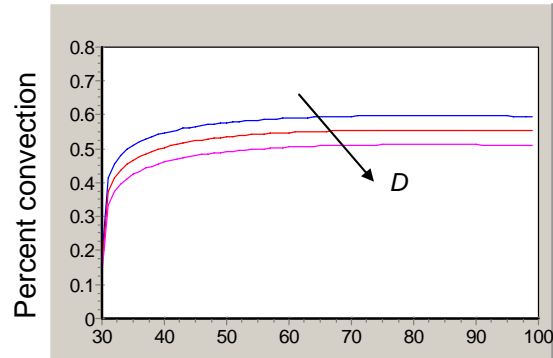

Bus bar temperature (C)

**COMMENTS:** (1) The trade-off between current-carrying capacity, operating temperature and bar diameter is shown in the first graph. If the surface temperature is not to exceed  $65^{\circ}\text{C}$ , the maximum current capacities for the 10, 20 and 40-mm diameter bus bars are 260, 700, and 1900 A, respectively.

(2) From the second graph with  $q'_{cv} / q'_{tot}$  vs.  $T$ , note that the convection heat transfer rate is typically comparable to the radiation heat transfer rate. Since the convection heat transfer increases with decreasing diameter, the convection transfer rate is relatively smaller for the larger diameter bus bars.

(3) The Workspace for the IHT program to perform the parametric analysis and generate the graphs is shown below. It is good practice to provide commentary with the code making your solution logic clear, and to summarize the results.

```
//Temperature Information (Celsius unless otherwise indicated)
```

```
Ts = 65
TsK = Ts + 273
Tsur = 30
TsurK = Tsur + 273
Tinf = 30
```

```
//Radiation (Stefan-Boltzmann constant and emissivity)
```

```
sigma = 5.67*10^-8
eps = 0.85
```

```
//Three bus bar diameters (m)
```

```
D1 = 10/1000
D2 = 20/1000
D3 = 40/1000
```

```
//Electrical resistivity (Ohm-m)
```

```
rho_e = (0.0171*10^-6) * (1 + 0.00396*(Ts - 25))
```

```
//Radiation per unit length (W/m)
```

```
qradp1 = eps*sigma*pi*D1*(TsK^4 - TsurK^4)
qradp2 = eps*sigma*pi*D2*(TsK^4 - TsurK^4)
qradp3 = eps*sigma*pi*D3*(TsK^4 - TsurK^4)
```

```
//Free convection coefficients (W/m^2K)
```

```
h1 = 1.21*(D1^-0.25)*(Ts - Tinf)^0.25
h2 = 1.21*(D2^-0.25)*(Ts - Tinf)^0.25
h3 = 1.21*(D3^-0.25)*(Ts - Tinf)^0.25
```

Continued...

### PROBLEM 1.61 (Cont.)

```
//Free convection per unit length (W/m)
qconvp1 = h1*D1*pi*(Ts - Tinf)
qconvp2 = h2*D2*pi*(Ts - Tinf)
qconvp3 = h3*D3*pi*(Ts - Tinf)
```

```
//Electrical resistance per unit length (Ohm/m)
Rep1 = rhoe/Ac1
Rep2 = rhoe/Ac2
Rep3 = rhoe/Ac3
```

```
//Cross sectional areas (m^2)
Ac1 = pi*D1*D1/4
Ac2 = pi*D2*D2/4
Ac3 = pi*D3*D3/4
```

```
//Energy balances (W/m)
-gradp1-qconvp1+l1*I1*Rep1 = 0
-gradp2-qconvp2+l2*I2*Rep2 = 0
-gradp3-qconvp3+l3*I3*Rep3 = 0
```

```
//Ratios of convection to total heat transfer
rat1 = qconvp1/(qconvp1 + gradp1)
rat2 = qconvp2/(qconvp2 + gradp2)
rat3 = qconvp3/(qconvp3 + gradp3)
```

## PROBLEM 1.62

**KNOWN:** Elapsed times corresponding to a temperature change from 15 to 14°C for a reference sphere and test sphere of unknown composition suddenly immersed in a stirred water-ice mixture. Mass and specific heat of reference sphere.

**FIND:** Specific heat of the test sphere of known mass.

**SCHEMATIC:**

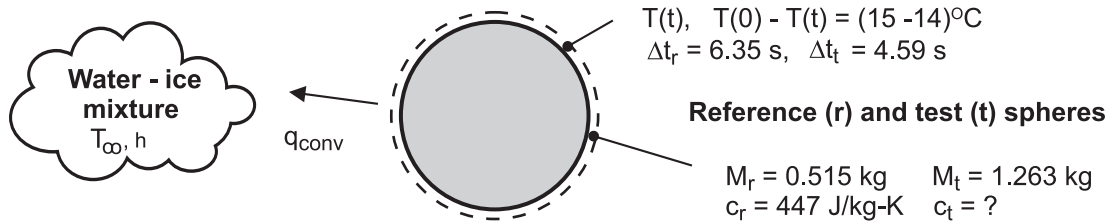

**ASSUMPTIONS:** (1) Spheres are of equal diameter, (2) Spheres experience temperature change from 15 to 14°C, (3) Spheres experience same convection heat transfer rate when the time rates of surface temperature are observed, (4) At any time, the temperatures of the spheres are uniform, (5) Negligible heat loss through the thermocouple wires.

**PROPERTIES:** Reference-grade sphere material:  $c_r = 447 \text{ J/kg}\cdot\text{K}$ .

**ANALYSIS:** Apply the conservation of energy requirement at an instant of time, Equation 1.12c, after a sphere has been immersed in the ice-water mixture at  $T_\infty$ .

$$\dot{E}_{\text{in}} - \dot{E}_{\text{out}} = \dot{E}_{\text{st}}$$

$$-q_{\text{conv}} = Mc \frac{dT}{dt}$$

where  $q_{\text{conv}} = h A_s (T - T_\infty)$ . Since the temperatures of the spheres are uniform, the change in energy storage term can be represented with the time rate of temperature change,  $dT/dt$ . The convection heat rates are equal at this instant of time, and hence the change in energy storage terms for the reference (r) and test (t) spheres must be equal.

$$M_r c_r \left. \frac{dT}{dt} \right|_r = M_t c_t \left. \frac{dT}{dt} \right|_t$$

Approximating the instantaneous differential change,  $dT/dt$ , by the difference change over a short period of time,  $\Delta T/\Delta t$ , the specific heat of the test sphere can be calculated.

$$0.515 \text{ kg} \times 447 \text{ J/kg}\cdot\text{K} \times \frac{(15 - 14) \text{ K}}{6.35 \text{ s}} = 1.263 \text{ kg} \times c_t \times \frac{(15 - 14) \text{ K}}{4.59 \text{ s}}$$

$$c_t = 132 \text{ J/kg}\cdot\text{K}$$

<

**COMMENTS:** Why was it important to perform the experiments with the reference and test spheres over the same temperature range (from 15 to 14°C)? Why does the analysis require that the spheres have uniform temperatures at all times?

### PROBLEM 1.63

**KNOWN:** Dimensions and emissivity of a cell phone charger. Surface temperature when plugged in. Temperature of air and surroundings. Convection heat transfer coefficient. Cost of electricity.

**FIND:** Daily cost of leaving the charger plugged in when not in use.

**SCHEMATIC:**

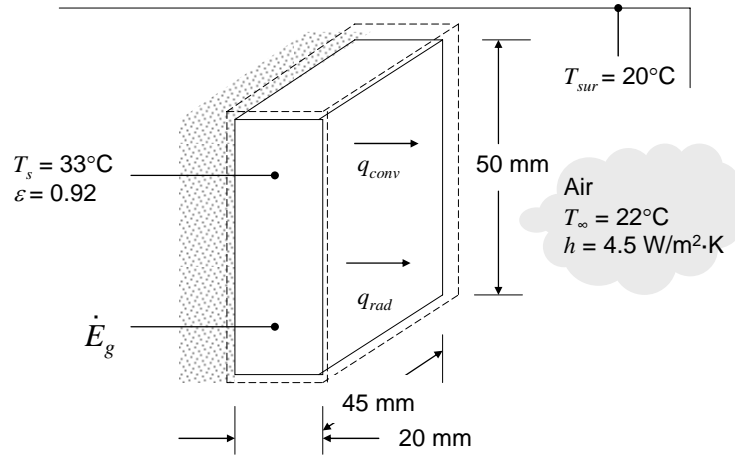

**ASSUMPTIONS:** (1) Steady-state conditions, (2) Convection and radiation are from five exposed surfaces of charger, (3) Large surroundings, (4) Negligible heat transfer from back of charger to wall and outlet.

**ANALYSIS:** At steady-state, an energy balance on the charger gives  $\dot{E}_{in} + \dot{E}_g = 0$ , where  $\dot{E}_g$  represents the conversion from electrical to thermal energy. The exposed area is  $A = (50 \text{ mm} \times 45 \text{ mm}) + 2(50 \text{ mm} \times 20 \text{ mm}) + 2(45 \text{ mm} \times 20 \text{ mm}) = 6050 \text{ mm}^2$ . Thus,

$$\begin{aligned} \dot{E}_g &= (q_{conv} + q_{rad}) = hA(T_s - T_\infty) + \varepsilon\sigma A(T_s^4 - T_{sur}^4) \\ &= \left[ 4.5 \text{ W/m}^2 \cdot \text{K}(33^\circ\text{C} - 22^\circ\text{C}) + 0.92 \times 5.67 \times 10^{-8} \text{ W/m}^2 \cdot \text{K}^4 \left( (306 \text{ K})^4 - (293 \text{ K})^4 \right) \right] \times 6050 \times 10^{-6} \text{ m}^2 \\ &= 0.74 \text{ W} \end{aligned}$$

This is the total rate of electricity used while the charger is plugged in. The daily cost of electricity is

$$\text{Cost} = 0.74 \text{ W} \times \$0.18/\text{kW}\cdot\text{h} \times 1 \text{ kW}/1000 \text{ W} \times 24 \text{ h/day} = \$0.0032/\text{day} \quad \leftarrow$$

**COMMENTS:** (1) The radiation and convection heat fluxes are  $73 \text{ W/m}^2$  and  $50 \text{ W/m}^2$ , respectively. Therefore, both modes of heat transfer are important. (2) The cost of leaving the charger plugged in when not in use is small.



### PROBLEM 1.64

**KNOWN:** Inner surface heating and new environmental conditions associated with a spherical shell of prescribed dimensions and material.

**FIND:** (a) Governing equation for variation of wall temperature with time. Initial rate of temperature change, (b) Steady-state wall temperature, (c) Effect of convection coefficient on canister temperature.

**SCHEMATIC:**

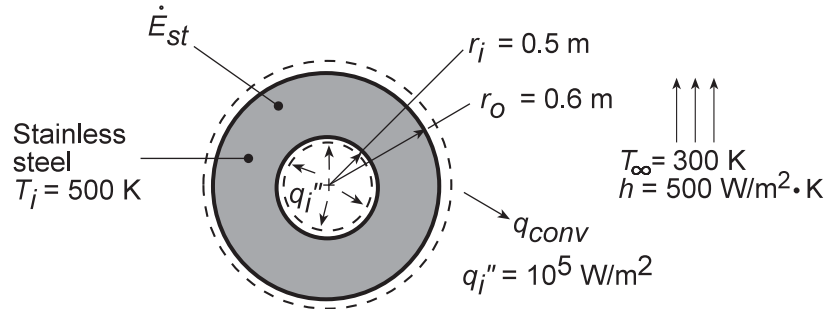

**ASSUMPTIONS:** (1) Negligible temperature gradients in wall, (2) Constant properties, (3) Uniform, time-independent heat flux at inner surface.

**PROPERTIES:** Table A.1, Stainless Steel, AISI 302:  $\rho = 8055 \text{ kg/m}^3$ ,  $c_p = 535 \text{ J/kg}\cdot\text{K}$ .

**ANALYSIS:** (a) Performing an energy balance on the shell at an instant of time,  $\dot{E}_{in} - \dot{E}_{out} = \dot{E}_{st}$ .

Identifying relevant processes and solving for  $dT/dt$ ,

$$q_i''(4\pi r_i^2) - h(4\pi r_o^2)(T - T_\infty) = \rho \frac{4}{3}\pi(r_o^3 - r_i^3)c_p \frac{dT}{dt}$$

$$\frac{dT}{dt} = \frac{3}{\rho c_p (r_o^3 - r_i^3)} [q_i'' r_i^2 - h r_o^2 (T - T_\infty)].$$

Substituting numerical values for the initial condition, find

$$\left. \frac{dT}{dt} \right|_i = \frac{3 \left[ 10^5 \frac{\text{W}}{\text{m}^2} (0.5\text{m})^2 - 500 \frac{\text{W}}{\text{m}^2 \cdot \text{K}} (0.6\text{m})^2 (500 - 300)\text{K} \right]}{8055 \frac{\text{kg}}{\text{m}^3} 535 \frac{\text{J}}{\text{kg} \cdot \text{K}} [(0.6)^3 - (0.5)^3] \text{m}^3}$$

$$\left. \frac{dT}{dt} \right|_i = -0.084 \text{ K/s} . \quad <$$

(b) Under steady-state conditions with  $\dot{E}_{st} = 0$ , it follows that

$$q_i''(4\pi r_i^2) = h(4\pi r_o^2)(T - T_\infty)$$

$$T = T_\infty + \frac{q_i''}{h} \left( \frac{r_i}{r_o} \right)^2 = 300\text{K} + \frac{10^5 \text{ W/m}^2}{500 \text{ W/m}^2 \cdot \text{K}} \left( \frac{0.5\text{m}}{0.6\text{m}} \right)^2 = 439\text{K} \quad <$$

Continued .....

### PROBLEM 1.64 (Cont.)

(c) Parametric calculations were performed using the IHT *First Law Model* for an *Isothermal Hollow Sphere*. As shown below, there is a sharp increase in temperature with decreasing values of  $h < 1000$   $\text{W}/\text{m}^2\cdot\text{K}$ . For  $T > 380$  K, boiling will occur at the canister surface, and for  $T > 410$  K a condition known as film boiling (Chapter 10) will occur. The condition corresponds to a precipitous reduction in  $h$  and increase in  $T$ .

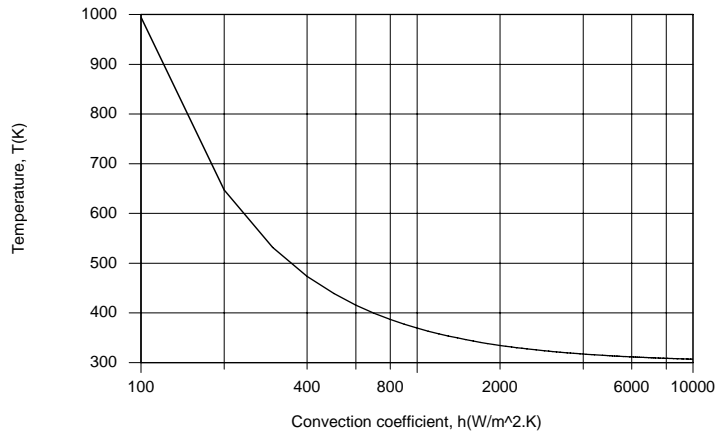

Although the canister remains well below the melting point of stainless steel for  $h = 100$   $\text{W}/\text{m}^2\cdot\text{K}$ , boiling should be avoided, in which case the convection coefficient should be maintained at  $h > 1000$   $\text{W}/\text{m}^2\cdot\text{K}$ .

**COMMENTS:** The governing equation of part (a) is a first order, nonhomogenous differential equation with constant coefficients. Its solution is  $\theta = (S/R)(1 - e^{-Rt}) + \theta_i e^{-Rt}$ , where  $\theta \equiv T - T_\infty$ ,

$S \equiv 3q_i'' r_i^2 / \rho c_p (r_o^3 - r_i^3)$ ,  $R = 3hr_o^2 / \rho c_p (r_o^3 - r_i^3)$ . Note results for  $t \rightarrow \infty$  and for  $S = 0$ .

## PROBLEM 1.65

**KNOWN:** Frost formation of 2-mm thickness on a freezer compartment. Surface exposed to convection process with ambient air.

**FIND:** Time required for the frost to melt,  $t_m$ .

**SCHEMATIC:**

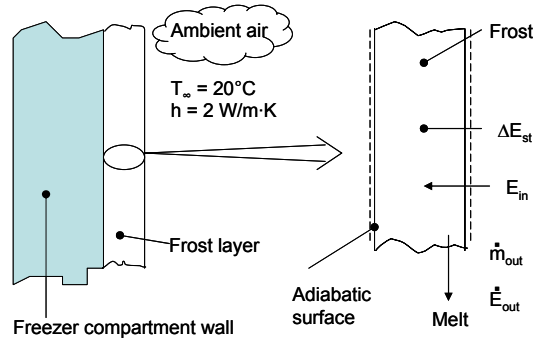

**ASSUMPTIONS:** (1) Frost is isothermal at the fusion temperature,  $T_f$ , (2) The water melt falls away from the exposed surface, (3) Frost exchanges radiation with surrounding frost, so net radiation exchange is negligible, and (4) Backside surface of frost formation is adiabatic.

**PROPERTIES:** Frost,  $\rho_f = 770 \text{ kg/m}^3$ ,  $h_{sf} = 334 \text{ kJ/kg}$ .

**ANALYSIS:** The time  $t_m$  required to melt a 2-mm thick frost layer may be determined by applying a mass balance and an energy balance (Eq 1.12b) over the differential time interval  $dt$  to a control volume around the frost layer.

$$dm_{st} = -\dot{m}_{out} dt \quad dE_{st} = (\dot{E}_{in} - \dot{E}_{out}) dt \quad (1a,b)$$

With  $h_f$  as the enthalpy of the melt and  $h_s$  as the enthalpy of frost, we have

$$dE_{st} = dm_{st} h_s \quad \dot{E}_{out} dt = \dot{m}_{out} h_f dt \quad (2a,b)$$

Combining Eqs. (1a) and (2a,b), Eq. (1b) becomes (with  $h_{sf} = h_f - h_s$ )

$$\dot{m}_{out} h_{sf} dt = \dot{E}_{in} dt = q''_{conv} A_s dt$$

Integrating both sides of the equation with respect to time, find

$$\rho_f A_s h_{sf} x_o = h A_s (T_\infty - T_f) t_m$$

$$t_m = \frac{\rho_f h_{sf} x_o}{h(T_\infty - T_f)}$$

$$t_m = \frac{700 \text{ kg/m}^3 \times 334 \times 10^3 \text{ J/kg} \times 0.002 \text{ m}}{2 \text{ W/m}^2 \cdot \text{K} (20 - 0) \text{ K}} = 11,690 \text{ s} = 3.2 \text{ hour} \quad <$$

**COMMENTS:** (1) The energy balance could be formulated intuitively by recognizing that the total heat *in* by convection during the time interval  $t_m$  ( $q''_{conv} \cdot t_m$ ) must be equal to the total latent energy for melting the frost layer ( $\rho x_o h_{sf}$ ). This equality is directly comparable to the derived expression above for  $t_m$ .

## PROBLEM 1.66

**KNOWN:** Vertical slab of Woods metal initially at its fusion temperature,  $T_f$ , joined to a substrate. Exposed surface is irradiated with laser source,  $G_\ell$  ( $\text{W}/\text{m}^2$ ).

**FIND:** Instantaneous rate of melting per unit area,  $\dot{m}_m''$  ( $\text{kg}/\text{s}\cdot\text{m}^2$ ), and the material removed in a period of 2 s, (a) Neglecting heat transfer from the irradiated surface by convection and radiation exchange, and (b) Allowing for convection and radiation exchange.

**SCHEMATIC:**

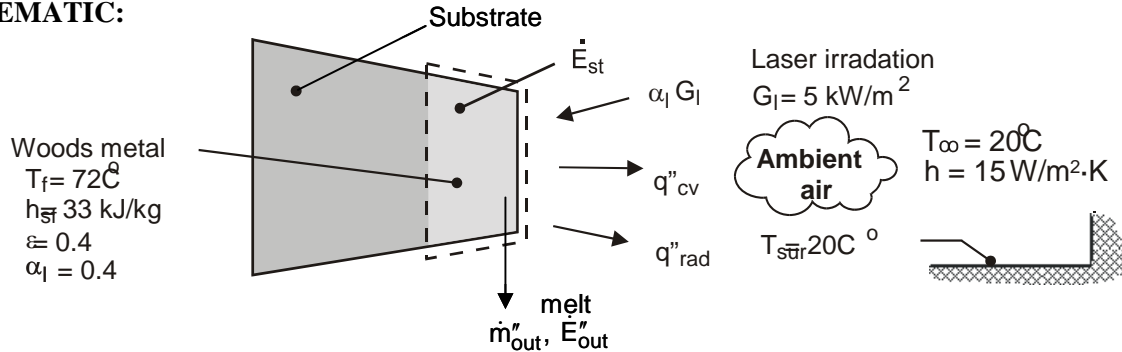

**ASSUMPTIONS:** (1) Woods metal slab is isothermal at the fusion temperature,  $T_f$ , and (2) The melt runs off the irradiated surface.

**ANALYSIS:** (a) The instantaneous rate of melting per unit area may be determined by applying a mass balance and an energy balance (Equation 1.12c) on the metal slab at an instant of time neglecting convection and radiation exchange from the irradiated surface.

$$\dot{m}_{st}'' = \dot{m}_{in}'' - \dot{m}_{out}'' \quad \dot{E}_{in}'' - \dot{E}_{out}'' = \dot{E}_{st}'' \quad (1a,b)$$

With  $h_f$  as the enthalpy of the melt and  $h_s$  as the enthalpy of the solid, we have

$$\dot{E}_{st}'' = \dot{m}_{st}'' h_s \quad \dot{E}_{out}'' = \dot{m}_{out}'' h_f \quad (2a,b)$$

Combining Equations (1a) and (2a,b), Equation (1b) becomes (with  $h_{sf} = h_f - h_s$ )

$$\dot{m}_{out}'' h_{sf} = \dot{E}_{in}'' = \alpha_l G_l$$

Thus the rate of melting is

$$\dot{m}_{out}'' = \alpha_l G_l / h_{sf} = 0.4 \times 5000 \text{ W/m}^2 / 33,000 \text{ J/kg} = 60.6 \times 10^{-3} \text{ kg/s} \times \text{m}^2 \quad <$$

The material removed in a 2s period per unit area is

$$M_{2s}'' = \dot{m}_{out}'' \times \Delta t = 121 \text{ g/m}^2 \quad <$$

(b) The energy balance considering convection and radiation exchange with the surroundings yields

$$\dot{m}_{out}'' h_{sf} = \alpha_l G_l - q''_{cv} - q''_{rad}$$

$$q''_{cv} = h(T_f - T_\infty) = 15 \text{ W/m}^2 \cdot \text{K} (72 - 20) \text{ K} = 780 \text{ W/m}^2$$

$$q''_{rad} = \epsilon \sigma (T_f^4 - T_\infty^4) = 0.4 \times 5.67 \times 10^{-8} \text{ W/m}^2 \cdot \text{K} \left( [72 + 273]^4 - [20 + 273]^4 \right) \text{ K}^4 = 154 \text{ W/m}^2$$

$$\dot{m}_{out}'' = 32.3 \times 10^{-3} \text{ kg/s} \cdot \text{m}^2 \quad M_{2s}'' = 64 \text{ g/m}^2 \quad <$$

**COMMENTS:** (1) The effects of heat transfer by convection and radiation reduce the estimate for the material removal rate by a factor of two. The heat transfer by convection is nearly 5 times larger than by radiation exchange.

Continued...

### **PROBLEM 1.66 (Cont.)**

- (2) Suppose the work piece were horizontal, rather than vertical, and the melt puddled on the surface rather than ran off. How would this affect the analysis?
- (3) Lasers are common heating sources for metals processing, including the present application of melting (heat transfer with phase change), as well as for heating work pieces during milling and turning (laser-assisted machining).

## PROBLEM 1.67

**KNOWN:** Dimensions, emissivity, and solar absorptivity of solar photovoltaic panel. Solar irradiation, air and surroundings temperature, and convection coefficient. Expression for conversion efficiency.

**FIND:** Electrical power output on (a) a still summer day, and (b) a breezy winter day.

**SCHEMATIC:**

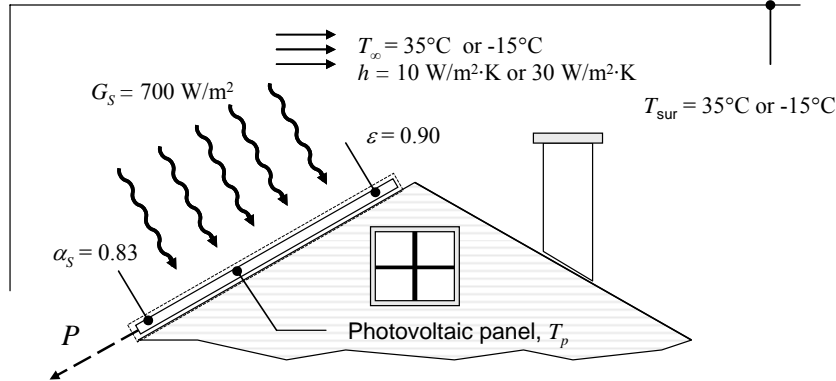

**ASSUMPTIONS:** (1) Steady-state conditions, (2) Lower surface of solar panel is insulated, (3) Radiation from the environment can be treated as radiation from large surroundings, with  $\alpha = \epsilon$ .

**ANALYSIS:** Recognize that there is conversion from thermal to electrical energy, therefore there is a negative generation term equal to the electrical power. Performing an energy balance on the solar panel gives

$$\dot{E}_{\text{in}} - \dot{E}_{\text{out}} + \dot{E}_g = 0$$

$$q_{\text{rad}} - q_{\text{conv}} - P = 0$$

$$\left[ \alpha_s G_s - \epsilon \sigma (T_s^4 - T_{\text{sur}}^4) \right] A - hA(T_s - T_{\infty}) - \eta \alpha_s G_s A = 0$$

Dividing by  $A$ , and substituting the expression for  $\eta$  as a function of  $T_p$  yields

$$\left[ \alpha_s G_s - \epsilon \sigma (T_p^4 - T_{\text{sur}}^4) \right] - h(T_p - T_{\infty}) - (0.553 - 0.001T_p) \alpha_s G_s = 0$$

(a) Substituting the parameter values for a summer day:

$$0.83 \times 700 \text{ W/m}^2 - 0.90 \times 5.67 \times 10^{-8} \text{ W/m}^2 \cdot \text{K}^4 (T_p^4 - (308 \text{ K})^4) - 10 \text{ W/m}^2 \cdot \text{K} (T_p - 308 \text{ K})$$

$$- (0.553 - 0.001T_p) \times 0.83 \times 700 \text{ W/m}^2 = 0$$

$$3799 \text{ W/m}^2 - 5.1 \times 10^{-8} \text{ W/m}^2 \cdot \text{K}^4 T_p^4 - 9.42 \text{ W/m}^2 \cdot \text{K} T_p = 0$$

Solving this equation for  $T_p$  using IHT or other software results in  $T_p = 335 \text{ K}$ . The electrical power can then be found from

$$\begin{aligned} P &= \eta \alpha_s G_s A = (0.553 - 0.001T_p) \alpha_s G_s A \\ &= (0.553 - 0.001 \text{ K}^{-1} \times 335 \text{ K}) \times 0.83 \times 700 \text{ W/m}^2 \times 8 \text{ m}^2 = 1010 \text{ W} \end{aligned} \quad <$$

(b) Repeating the calculation for the winter conditions yields  $T_p = 270 \text{ K}$ ,  $P = 1310 \text{ W}$ . <

**COMMENTS:** (1) The conversion efficiency for most photovoltaic materials is higher at lower temperatures. Therefore, for the same solar irradiation, more electrical power is generated in winter conditions. (2) The total solar energy generated would generally be less in the winter due to lower irradiation values and a shorter day.

## PROBLEM 1.68

**KNOWN:** Hot formed paper egg carton of prescribed mass, surface area, and water content exposed to infrared heater providing known radiant flux.

**FIND:** Whether water content can be reduced by 10% of the total mass during the 18s period carton is on conveyor.

**SCHEMATIC:**

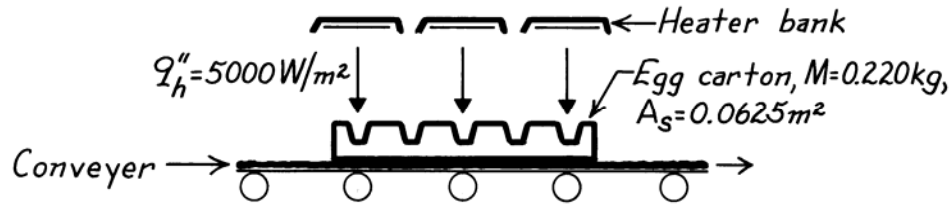

**ASSUMPTIONS:** (1) All the radiant flux from the heater bank causes evaporation of water, (2) Negligible heat loss from carton by convection and radiation, (3) Negligible mass loss occurs from bottom side.

**PROPERTIES:** Water (given):  $h_{fg} = 2400 \text{ kJ/kg}$ .

**ANALYSIS:** Define a control surface about the carton, and write conservation of mass and energy for an interval of time,  $\Delta t$ ,

$$\Delta m_{st} = -\dot{m}_{out} \Delta t \quad \Delta E_{st} = (\dot{E}_{in} - \dot{E}_{out}) \Delta t \quad (1a,b)$$

With  $h_f$  as the enthalpy of the liquid water and  $h_g$  as the enthalpy of water vapor, we have

$$\Delta E_{st} = \Delta m_{st} h_f \quad \dot{E}_{out} \Delta t = \dot{m}_{out} h_g \Delta t \quad (2a,b)$$

Combining Equations (1a) and (2a,b), Equation (1b) becomes (with  $h_{fg} = h_g - h_f$ )

$$\dot{m}_{out} h_{fg} \Delta t = \dot{E}_{in} \Delta t = q_h'' A_s \Delta t$$

where  $q_h''$  is the absorbed radiant heat flux from the heater. Hence,

$$\Delta m = \dot{m}_{out} \Delta t = q_h'' A_s \Delta t / h_{fg} = 5000 \text{ W/m}^2 \times 0.0625 \text{ m}^2 \times 18 \text{ s} / 2400 \text{ kJ/kg} = 0.00234 \text{ kg}$$

The chief engineer's requirement was to remove 10% of the water content, or

$$\Delta M_{req} = M \times 0.10 = 0.220 \text{ kg} \times 0.10 = 0.022 \text{ kg}$$

which is nearly an order of magnitude larger than the evaporative loss. Considering heat losses by convection and radiation, the actual water removal from the carton will be less than  $\Delta M$ . Hence, the purchase should not be recommended, since the desired water removal cannot be achieved. <

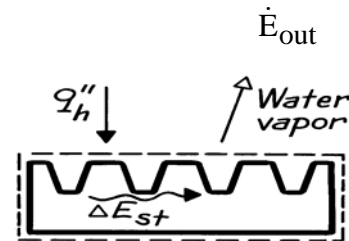

## PROBLEM 1.69

**KNOWN:** Average heat sink temperature when total dissipation is 20 W with prescribed air and surroundings temperature, sink surface area and emissivity.

**FIND:** Sink temperature when dissipation is 30 W.

**SCHEMATIC:**

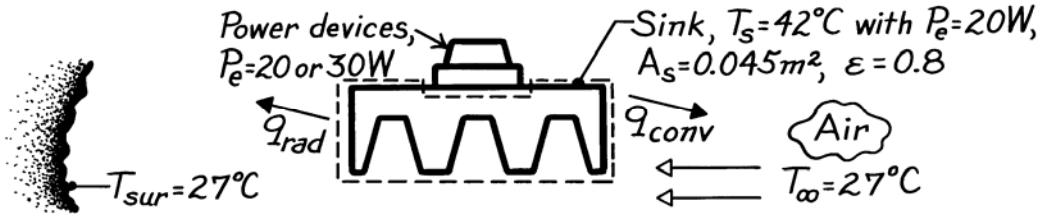

**ASSUMPTIONS:** (1) Steady-state conditions, (2) All dissipated power in devices is transferred to the sink, (3) Sink is isothermal, (4) Surroundings and air temperature remain the same for both power levels, (5) Convection coefficient is the same for both power levels, (6) Heat sink is a small surface within a large enclosure, the surroundings.

**ANALYSIS:** Define a control volume around the heat sink. Power dissipated within the devices is transferred into the sink, while the sink loses heat to the ambient air and surroundings by convection and radiation exchange, respectively.

$$\begin{aligned} \dot{E}_{in} - \dot{E}_{out} &= 0 \\ P_e - hA_s(T_s - T_\infty) - A_s\epsilon\sigma(T_s^4 - T_{sur}^4) &= 0. \end{aligned} \quad (1)$$

Consider the situation when  $P_e = 20 \text{ W}$  for which  $T_s = 42^\circ\text{C}$ ; find the value of  $h$ .

$$\begin{aligned} h &= \left[ P_e / A_s - \epsilon\sigma(T_s^4 - T_{sur}^4) \right] / (T_s - T_\infty) \\ h &= \left[ 20 \text{ W} / 0.045 \text{ m}^2 - 0.8 \times 5.67 \times 10^{-8} \text{ W/m}^2 \cdot \text{K}^4 (315^4 - 300^4) \text{ K}^4 \right] / (315 - 300) \text{ K} \\ h &= 24.4 \text{ W/m}^2 \cdot \text{K}. \end{aligned}$$

For the situation when  $P_e = 30 \text{ W}$ , using this value for  $h$  with Eq. (1), obtain

$$\begin{aligned} 30 \text{ W} - 24.4 \text{ W/m}^2 \cdot \text{K} \times 0.045 \text{ m}^2 (T_s - 300) \text{ K} \\ - 0.045 \text{ m}^2 \times 0.8 \times 5.67 \times 10^{-8} \text{ W/m}^2 \cdot \text{K}^4 (T_s^4 - 300^4) \text{ K}^4 &= 0 \\ 30 &= 1.098(T_s - 300) + 2.041 \times 10^{-9} (T_s^4 - 300^4). \end{aligned}$$

By trial-and-error, find

$$T_s \approx 322 \text{ K} = 49^\circ\text{C}. \quad <$$

**COMMENTS:** (1) It is good practice to express all temperatures in kelvin units when using energy balances involving radiation exchange.

(2) Note that we have assumed  $A_s$  is the same for the convection and radiation processes. Since not all portions of the fins are completely exposed to the surroundings,  $A_{s,rad}$  is less than  $A_{s,conv} = A_s$ .

(3) Is the assumption that the heat sink is isothermal reasonable?



## PROBLEM 1.70

**KNOWN:** Number and power dissipation of PCBs in a computer console. Convection coefficient associated with heat transfer from individual components in a board. Inlet temperature of cooling air and fan power requirement. Maximum allowable temperature rise of air. Heat flux from component most susceptible to thermal failure.

**FIND:** (a) Minimum allowable volumetric flow rate of air, (b) Preferred location and corresponding surface temperature of most thermally sensitive component.

**SCHEMATIC:**

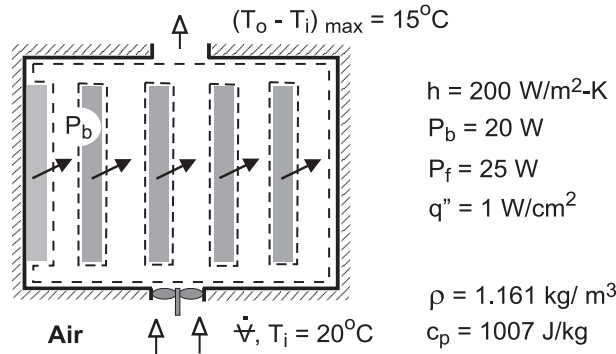

**ASSUMPTIONS:** (1) Steady-state, (2) Constant air properties, (3) Negligible potential and kinetic energy changes of air flow, (4) Negligible heat transfer from console to ambient air, (5) Uniform convection coefficient for all components.

**ANALYSIS:** (a) For a control surface about the air space in the console, conservation of energy for an open system, Equation (1.12d), reduces to

$$\dot{m}(u_t + pv)_{\text{in}} - \dot{m}(u_t + pv)_{\text{out}} + q - \dot{W} = 0$$

where  $u_t + pv = i$ ,  $q = 5P_b$ , and  $\dot{W} = -P_f$ . Hence, with  $\dot{m}(i_{\text{in}} - i_{\text{out}}) = \dot{m}c_p(T_{\text{in}} - T_{\text{out}})$ ,

$$\dot{m}c_p(T_{\text{out}} - T_{\text{in}}) = 5P_b + P_f$$

For a maximum allowable temperature rise of  $15^\circ\text{C}$ , the required mass flow rate is

$$\dot{m} = \frac{5P_b + P_f}{c_p(T_{\text{out}} - T_{\text{in}})} = \frac{5 \times 20 \text{ W} + 25 \text{ W}}{1007 \text{ J/kg} \cdot \text{K}(15^\circ\text{C})} = 8.28 \times 10^{-3} \text{ kg/s}$$

The corresponding volumetric flow rate is

$$\dot{V} = \frac{\dot{m}}{\rho} = \frac{8.28 \times 10^{-3} \text{ kg/s}}{1.161 \text{ kg/m}^3} = 7.13 \times 10^{-3} \text{ m}^3/\text{s} \quad <$$

(b) The component which is most susceptible to thermal failure should be mounted at the bottom of one of the PCBs, where the air is coolest. From the corresponding form of Newton's law of cooling,  $q'' = h(T_s - T_{\text{in}})$ , the surface temperature is

$$T_s = T_{\text{in}} + \frac{q''}{h} = 20^\circ\text{C} + \frac{1 \times 10^4 \text{ W/m}^2}{200 \text{ W/m}^2 \cdot \text{K}} = 70^\circ\text{C} \quad <$$

**COMMENTS:** (1) Although the mass flow rate is invariant, the volumetric flow rate increases as the air is heated in its passage through the console, causing a reduction in the density. However, for the prescribed temperature rise, the change in  $\rho$ , and hence the effect on  $\dot{V}$ , is small. (2) If the thermally sensitive component were located at the top of a PCB, it would be exposed to warmer air ( $T_o = 35^\circ\text{C}$ ) and the surface temperature would be  $T_s = 85^\circ\text{C}$ .

## PROBLEM 1.71

**KNOWN:** Surface-mount transistor with prescribed dissipation and convection cooling conditions.

**FIND:** (a) Case temperature for mounting arrangement with air-gap and conductive paste between case and circuit board, (b) Consider options for increasing  $\dot{E}_g$ , subject to the constraint that  $T_C = 40^\circ\text{C}$ .

**SCHEMATIC:**

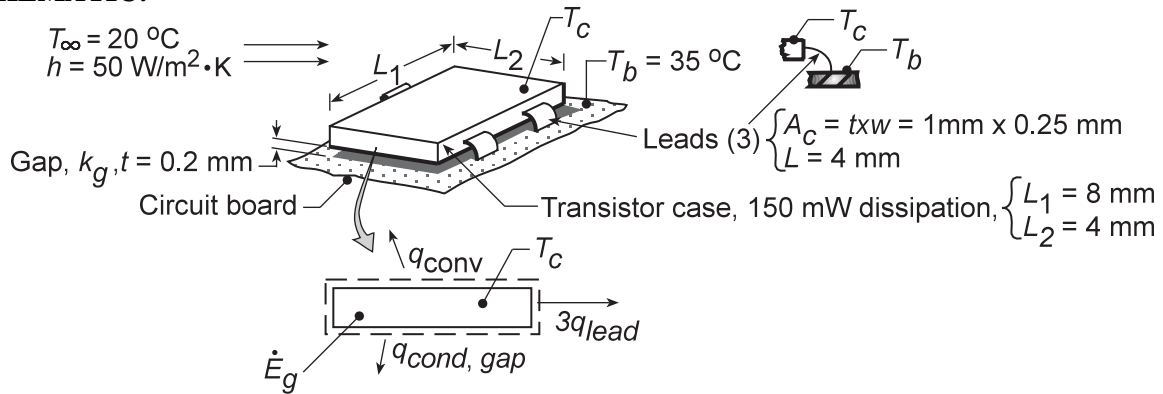

**ASSUMPTIONS:** (1) Steady-state conditions, (2) Transistor case is isothermal, (3) Upper surface experiences convection; negligible losses from edges, (4) Leads provide conduction path between case and board, (5) Negligible radiation, (6) Negligible energy generation in leads due to current flow, (7) Negligible convection from surface of leads.

**PROPERTIES:** (Given): Air,  $k_{g,a} = 0.0263 \text{ W/m}\cdot\text{K}$ ; Paste,  $k_{g,p} = 0.12 \text{ W/m}\cdot\text{K}$ ; Metal leads,  $k_\ell = 25 \text{ W/m}\cdot\text{K}$ .

**ANALYSIS:** (a) Define the transistor as the system and identify modes of heat transfer.

$$\dot{E}_{\text{in}} - \dot{E}_{\text{out}} + \dot{E}_g = \Delta \dot{E}_{\text{st}} = 0$$

$$-q_{\text{conv}} - q_{\text{cond,gap}} - 3q_{\text{lead}} + \dot{E}_g = 0$$

$$-hA_s(T_C - T_\infty) - k_g A_s \frac{T_C - T_b}{t} - 3k_\ell A_c \frac{T_C - T_b}{L} + \dot{E}_g = 0$$

where  $A_s = L_1 \times L_2 = 4 \times 8 \text{ mm}^2 = 32 \times 10^{-6} \text{ m}^2$  and  $A_c = t \times w = 0.25 \times 1 \text{ mm}^2 = 25 \times 10^{-8} \text{ m}^2$ .

Rearranging and solving for  $T_C$ ,

$$T_C = \left\{ hA_s T_\infty + \left[ k_g A_s / t + 3(k_\ell A_c / L) \right] T_b + \dot{E}_g \right\} / \left[ hA_s + k_g A_s / t + 3(k_\ell A_c / L) \right]$$

Substituting numerical values, with the *air-gap condition* ( $k_{g,a} = 0.0263 \text{ W/m}\cdot\text{K}$ )

$$T_C = \left\{ 50 \text{ W/m}^2 \cdot \text{K} \times 32 \times 10^{-6} \text{ m}^2 \times 20^\circ\text{C} + \left[ (0.0263 \text{ W/m}\cdot\text{K} \times 32 \times 10^{-6} \text{ m}^2 / 0.2 \times 10^{-3} \text{ m}) + 3(25 \text{ W/m}\cdot\text{K} \times 25 \times 10^{-8} \text{ m}^2 / 4 \times 10^{-3} \text{ m}) \right] 35^\circ\text{C} \right\} / \left[ 1.600 \times 10^{-3} + 4.208 \times 10^{-3} + 4.688 \times 10^{-3} \right] \text{ W/K}$$

$$T_C = 47.0^\circ\text{C}.$$

<

Continued...

### PROBLEM 1.71 (Cont.)

With the *paste condition* ( $k_{g,p} = 0.12 \text{ W/m}\cdot\text{K}$ ),  $T_C = 39.9^\circ\text{C}$ . As expected, the effect of the conductive paste is to improve the coupling between the circuit board and the case. Hence,  $T_C$  decreases.

(b) Using the keyboard to enter model equations into the workspace, IHT has been used to perform the desired calculations. For values of  $k_\ell = 200$  and  $400 \text{ W/m}\cdot\text{K}$  and convection coefficients in the range from  $50$  to  $250 \text{ W/m}^2\cdot\text{K}$ , the energy balance equation may be used to compute the power dissipation for a maximum allowable case temperature of  $40^\circ\text{C}$ .

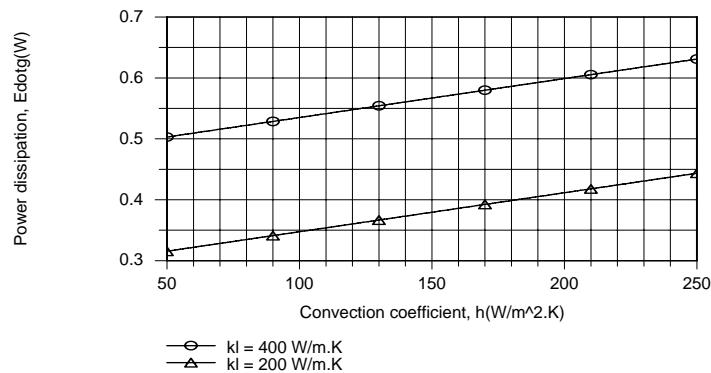

As indicated by the energy balance, the power dissipation increases linearly with increasing  $h$ , as well as with increasing  $k_\ell$ . For  $h = 250 \text{ W/m}^2\cdot\text{K}$  (enhanced air cooling) and  $k_\ell = 400 \text{ W/m}\cdot\text{K}$  (copper leads), the transistor may dissipate up to  $0.63 \text{ W}$ .

**COMMENTS:** Additional benefits may be derived by increasing heat transfer across the gap separating the case from the board, perhaps by inserting a highly conductive material in the gap.

## PROBLEM 1.72

**KNOWN:** Top surface of car roof absorbs solar flux,  $q''_{S,abs}$ , and experiences for case (a): convection with air at  $T_\infty$  and for case (b): the same convection process and radiation emission from the roof.

**FIND:** Temperature of the roof,  $T_s$ , for the two cases. Effect of airflow on roof temperature.

**SCHEMATIC:**

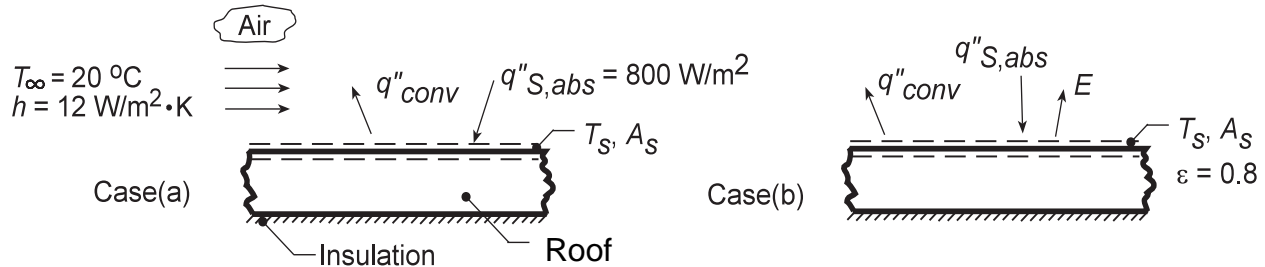

**ASSUMPTIONS:** (1) Steady-state conditions, (2) Negligible heat transfer to auto interior, (3) Negligible radiation from atmosphere.

**ANALYSIS:** (a) Apply an energy balance to the control surfaces shown on the schematic. For an instant of time,  $\dot{E}_{in} - \dot{E}_{out} = 0$ . Neglecting radiation emission, the relevant processes are convection between the plate and the air,  $q''_{conv}$ , and the absorbed solar flux,  $q''_{S,abs}$ . Considering the roof to have an area  $A_s$ ,

$$q''_{S,abs} \cdot A_s - hA_s (T_s - T_\infty) = 0$$

$$T_s = T_\infty + q''_{S,abs}/h$$

$$T_s = 20^\circ\text{C} + \frac{800\text{W/m}^2}{12\text{W/m}^2 \cdot \text{K}} = 20^\circ\text{C} + 66.7^\circ\text{C} = 86.7^\circ\text{C} \quad <$$

(b) With radiation emission from the surface, the energy balance has the form

$$q''_{S,abs} \cdot A_s - q_{conv} - E \cdot A_s = 0$$

$$q''_{S,abs} A_s - hA_s (T_s - T_\infty) - \varepsilon A_s \sigma T_s^4 = 0.$$

Substituting numerical values, with temperature in absolute units (K),

$$800 \frac{\text{W}}{\text{m}^2} - 12 \frac{\text{W}}{\text{m}^2 \cdot \text{K}} (T_s - 293\text{K}) - 0.8 \times 5.67 \times 10^{-8} \frac{\text{W}}{\text{m}^2 \cdot \text{K}^4} T_s^4 = 0$$

$$12T_s + 4.536 \times 10^{-8} T_s^4 = 4316$$

It follows that  $T_s = 320 \text{ K} = 47^\circ\text{C}$ . <

Continued...

### PROBLEM 1.72 (Cont.)

(c) Parametric calculations were performed using the IHT *First Law Model* for an *Isothermal Plane Wall*. As shown below, the roof temperature depends strongly on the velocity of the auto relative to the ambient air. For a convection coefficient of  $h = 40 \text{ W/m}^2\cdot\text{K}$ , which would be typical for a velocity of 55 mph, the roof temperature would exceed the ambient temperature by less than  $10^\circ\text{C}$ .

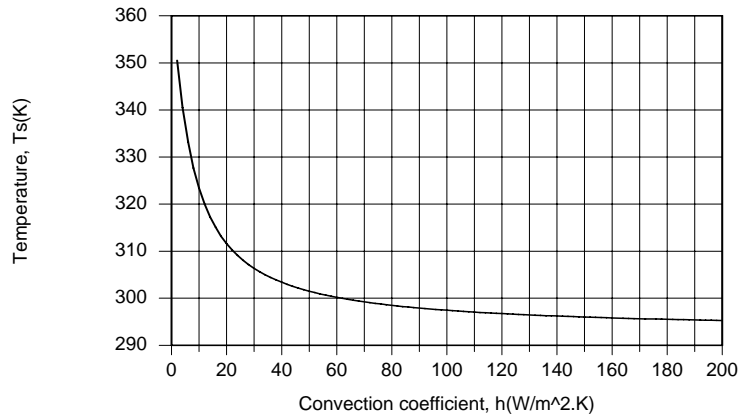

**COMMENTS:** By considering radiation emission,  $T_s$  decreases, as expected. Note the manner in which  $q''_{\text{conv}}$  is formulated using Newton's law of cooling; since  $q''_{\text{conv}}$  is shown leaving the control surface, the rate equation must be  $h(T_s - T_\infty)$  and not  $h(T_\infty - T_s)$ .

## PROBLEM 1.73

**KNOWN:** Hot plate suspended in a room, plate temperature, room temperature and surroundings temperature, convection coefficient and plate emissivity, mass and specific heat of the plate.

**FIND:** (a) The time rate of change of the plate temperature, and (b) Heat loss by convection and heat loss by radiation.

**SCHEMATIC:**

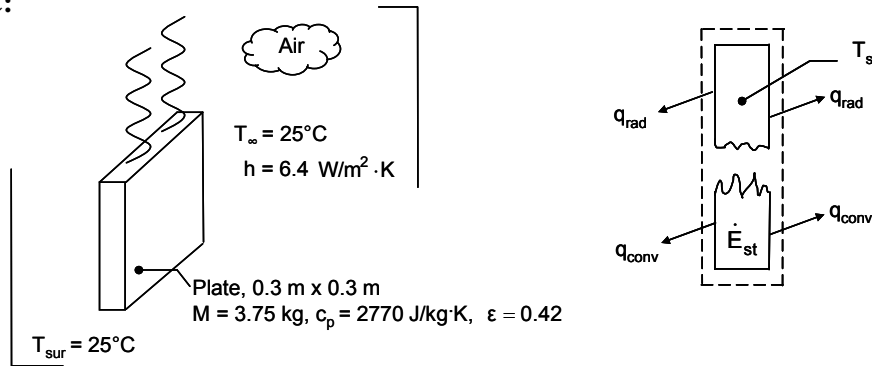

**ASSUMPTIONS:** (1) Plate is isothermal and at uniform temperature, (2) Large surroundings, (3) Negligible heat loss through suspension wires.

**ANALYSIS:** For a control volume about the plate, the conservation of energy requirement is

$$\dot{E}_{\text{in}} - \dot{E}_{\text{out}} = \dot{E}_{\text{st}} \quad (1)$$

$$\text{where } \dot{E}_{\text{st}} = Mc_p \frac{dT}{dt} \quad (2)$$

$$\text{and } \dot{E}_{\text{in}} - \dot{E}_{\text{out}} = \epsilon A \sigma (T_{\text{sur}}^4 - T_s^4) + hA(T_{\infty} - T_s) \quad (3)$$

$$\text{Combining Eqs. (1) through (3) yields } \frac{dT}{dt} = \frac{A[\epsilon \sigma (T_{\text{sur}}^4 - T_s^4) + h(T_{\infty} - T_s)]}{Mc_p}$$

Noting that  $T_{\text{sur}} = 25^{\circ}\text{C} + 273 \text{ K} = 298 \text{ K}$  and  $T_s = 225^{\circ}\text{C} + 273 \text{ K} = 498 \text{ K}$ ,

$$\frac{dT}{dt} = \frac{\{2 \times 0.3 \text{ m} \times 0.3 \text{ m} [0.42 \times 5.67 \times 10^{-8} \frac{\text{W}}{\text{m}^2 \cdot \text{K}^4} \times (498^4 - 298^4) \text{ K}^4] + 6.4 \frac{\text{W}}{\text{m}^2 \cdot \text{K}} \times (25^{\circ}\text{C} - 225^{\circ}\text{C})\}}{3.75 \text{ kg} \times 2770 \frac{\text{J}}{\text{kg} \cdot \text{K}}}$$

$$= -0.044 \text{ K/s} \quad <$$

The heat loss by radiation is the first term in the numerator of the preceding expression and is

$$q_{\text{rad}} = 230 \text{ W} \quad <$$

The heat loss by convection is the second term in the preceding expression and is

$$q_{\text{conv}} = 230 \text{ W} \quad <$$

**COMMENTS:** (1) Note the importance of using kelvins when working with radiation heat transfer. (2) The temperature difference in Newton's law of cooling may be expressed in either kelvins or degrees Celsius. (3) Radiation and convection losses are of the same magnitude. This is typical of many natural convection systems involving gases such as air.

## PROBLEM 1.74

**KNOWN:** Daily thermal energy generation, surface area, temperature of the environment, and heat transfer coefficient.

**FIND:** (a) Skin temperature when the temperature of the environment is 20°C, and (b) Rate of perspiration to maintain skin temperature of 33°C when the temperature of the environment is 33°C.

**SCHEMATIC:**

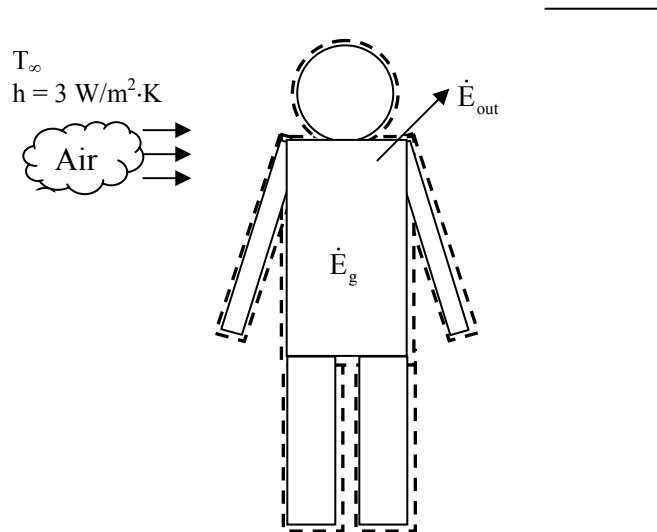

**ASSUMPTIONS:** (1) Steady-state conditions, (2) Thermal energy is generated at a constant rate throughout the day, (3) Air and surrounding walls are at same temperature, (4) Skin temperature is uniform, (5) Bathing suit has no effect on heat loss from body, (6) Heat loss is by convection and radiation to the environment, and by perspiration in Part 2. (Heat loss due to respiration, excretion of waste, etc., is negligible.), (7) Large surroundings.

**PROPERTIES:** Table A.11, skin:  $\varepsilon = 0.95$ , Table A.6, water (306 K):  $\rho = 994 \text{ kg/m}^3$ ,  $h_{fg} = 2421 \text{ kJ/kg}$ .

**ANALYSIS:**

(a) The rate of energy generation is:

$$\dot{E}_g = 2000 \times 10^3 \text{ cal/day} / (0.239 \text{ cal/J} \times 86,400 \text{ s/day}) = 96.9 \text{ W}$$

Under steady-state conditions, an energy balance on the human body yields:

$$\dot{E}_g - \dot{E}_{out} = 0$$

Thus  $\dot{E}_{out} = q = 96.9 \text{ W}$ . Energy outflow is due to convection and net radiation from the surface to the environment, Equations 1.3a and 1.7, respectively.

$$\dot{E}_{out} = hA(T_s - T_\infty) + \varepsilon\sigma A(T_s^4 - T_{sur}^4)$$

Substituting numerical values

Continued...

### PROBLEM 1.74 (Cont.)

$$96.9 \text{ W} = 3 \text{ W/m}^2 \cdot \text{K} \times 1.8 \text{ m}^2 \times (T_s - 293 \text{ K}) \\ + 0.95 \times 5.67 \times 10^{-8} \text{ W/m}^2 \cdot \text{K}^4 \times 1.8 \text{ m}^2 \times (T_s^4 - (293 \text{ K})^4)$$

and solving either by trial-and-error or using *IHT* or other equation solver, we obtain

$$T_s = 299 \text{ K} = 26^\circ\text{C}$$

&lt;

Since the comfortable range of skin temperature is typically  $32 - 35^\circ\text{C}$ , we usually wear clothing warmer than a bathing suit when the temperature of the environment is  $20^\circ\text{C}$ .

(b) If the skin temperature is  $33^\circ\text{C}$  when the temperature of the environment is  $33^\circ\text{C}$ , there will be no heat loss due to convection or radiation. Thus, all the energy generated must be removed due to perspiration:

$$\dot{E}_{\text{out}} = \dot{m}h_{\text{fg}}$$

We find:

$$\dot{m} = \dot{E}_{\text{out}}/h_{\text{fg}} = 96.9 \text{ W}/2421 \text{ kJ/kg} = 4.0 \times 10^{-5} \text{ kg/s}$$

This is the perspiration rate in mass per unit time. The volumetric rate is:

$$\dot{V} = \dot{m}/\rho = 4.0 \times 10^{-5} \text{ kg/s} / 994 \text{ kg/m}^3 = 4.0 \times 10^{-8} \text{ m}^3/\text{s} = 4.0 \times 10^{-5} \text{ l/s}$$

&lt;

**COMMENTS:** (1) In Part 1, heat losses due to convection and radiation are  $32.4 \text{ W}$  and  $60.4 \text{ W}$ , respectively. Thus, it would not have been reasonable to neglect radiation. Care must be taken to include radiation when the heat transfer coefficient is small, even if the problem statement does not give any indication of its importance. (2) The rate of thermal energy generation is not constant throughout the day; it adjusts to maintain a constant core temperature. Thus, the energy generation rate may decrease when the temperature of the environment goes up, or increase (for example, by shivering) when the temperature of the environment is low. (3) The skin temperature is not uniform over the entire body. For example, the extremities are usually cooler. Skin temperature also adjusts in response to changes in the environment. As the temperature of the environment increases, more blood flow will be directed near the surface of the skin to increase its temperature, thereby increasing heat loss. (4) If the perspiration rate found in Part 2 was maintained for eight hours, the person would lose 1.2 liters of liquid. This demonstrates the importance of consuming sufficient amounts of liquid in warm weather.



## PROBLEM 1.75

**KNOWN:** Thermal conductivity, thickness and temperature difference across a sheet of rigid extruded insulation. Cold wall temperature, surroundings temperature, ambient temperature and emissivity.

**FIND:** (a) The value of the convection heat transfer coefficient on the cold wall side in units of  $W/m^2 \cdot ^\circ C$  or  $W/m^2 \cdot K$ , and, (b) The cold wall surface temperature for emissivities over the range  $0.05 \leq \epsilon \leq 0.95$  for a hot wall temperature of  $T_1 = 30^\circ C$ .

**SCHEMATIC:**

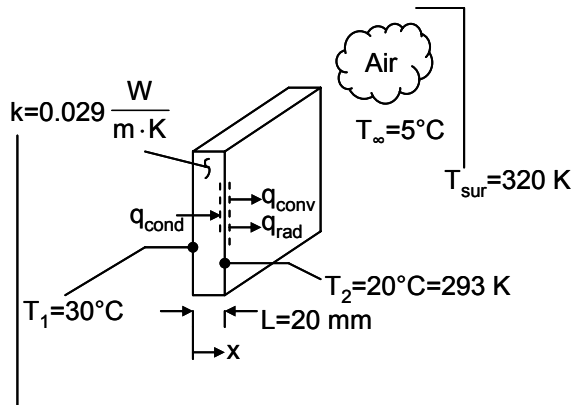

**ASSUMPTIONS:** (1) One-dimensional conduction in the x-direction, (2) Steady-state conditions, (c) Constant properties, (4) Large surroundings.

**ANALYSIS:**

(a) An energy balance on the control surface shown in the schematic yields

$$\dot{E}_{in} = \dot{E}_{out} \quad \text{or} \quad q_{cond} = q_{conv} + q_{rad}$$

Substituting from Fourier's law, Newton's law of cooling, and Eq. 1.7 yields

$$k \frac{T_1 - T_2}{L} = h(T_2 - T_\infty) + \epsilon \sigma (T_2^4 - T_{sur}^4) \quad (1)$$

or

$$h = \frac{1}{(T_2 - T_\infty)} \left[ k \frac{T_1 - T_2}{L} - \epsilon \sigma (T_2^4 - T_{sur}^4) \right]$$

Substituting values,

$$h = \frac{1}{(20 - 5)^\circ C} \left[ 0.029 \frac{W}{m \cdot K} \times \frac{(30 - 20)^\circ C}{0.02 \text{ m}} - 0.95 \times 5.67 \times 10^{-8} \frac{W}{m^2 \cdot K^4} (293^4 - 320^4) K^4 \right]$$

$$h = 12.2 \frac{W}{m^2 \cdot K} \quad <$$

Continued...

### PROBLEM 1.75 (Cont.)

(b) Equation (1) may be solved iteratively to find  $T_2$  for any emissivity  $\epsilon$ . *IHT* was used for this purpose, yielding the following.

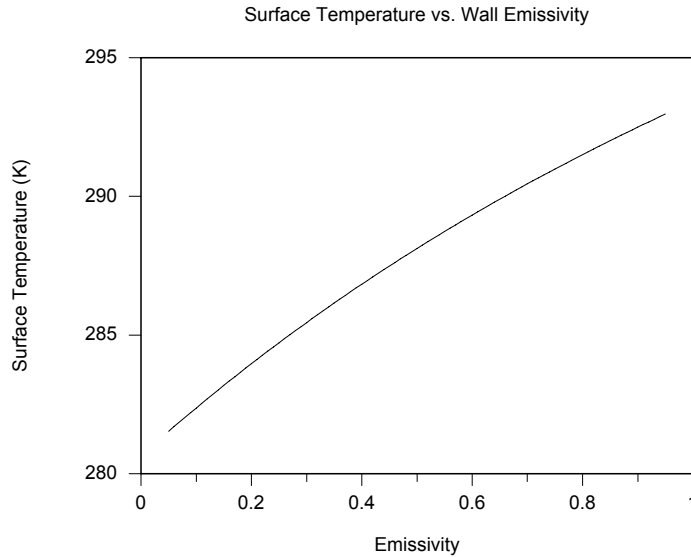

**COMMENTS:** (1) Note that as the wall emissivity increases, the surface temperature increases since the surroundings temperature is relatively hot. (2) The *IHT* code used in part (b) is shown below. (3) It is a good habit to work in temperature units of kelvins when radiation heat transfer is included in the solution of the problem.

```
//Problem 1.75
```

```
h = 12.2 //W/m^2·K (convection coefficient)
```

```
L = 0.02 //m (sheet thickness)
```

```
k = 0.029 //W/m·K (thermal conductivity)
```

```
T1 = 30 + 273 //K (hot wall temperature)
```

```
Tsur = 320 //K (surroundings temperature)
```

```
sigma = 5.67*10^-8 //W/m^2·K^4 (Stefan -Boltzmann constant)
```

```
Tinf = 5 + 273 //K (ambient temperature)
```

```
e = 0.95 //emissivity
```

```
//Equation (1) is
```

$$k \cdot (T_1 - T_2) / L = h \cdot (T_2 - T_{\text{inf}}) + e \cdot \sigma \cdot (T_2^4 - T_{\text{sur}}^4)$$

## PROBLEM 1.76

**KNOWN:** Thickness and thermal conductivity,  $k$ , of an oven wall. Temperature and emissivity,  $\epsilon$ , of front surface. Temperature and convection coefficient,  $h$ , of air. Temperature of large surroundings.

**FIND:** (a) Temperature of back surface, (b) Effect of variations in  $k$ ,  $h$  and  $\epsilon$ .

**SCHEMATIC:**

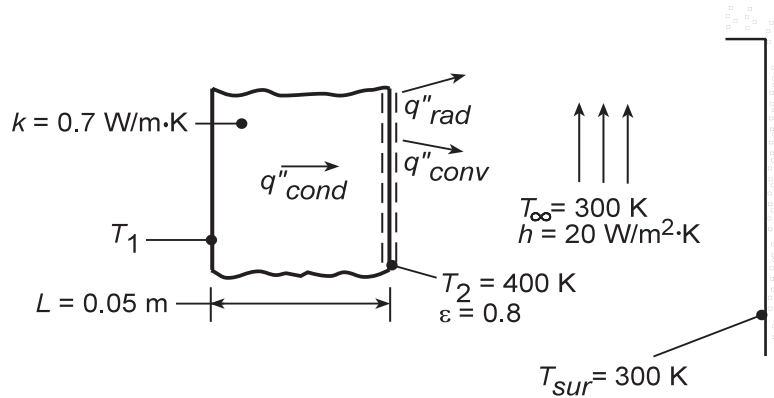

**ASSUMPTIONS:** (1) Steady-state, (2) One-dimensional conduction, (3) Radiation exchange with large surroundings.

**ANALYSIS:** (a) Applying an energy balance, Eq. 1.13 to the front surface and substituting the appropriate rate equations, Eqs. 1.2, 1.3a and 1.7, find

$$k \frac{T_1 - T_2}{L} = h(T_2 - T_\infty) + \epsilon \sigma (T_2^4 - T_{sur}^4).$$

Substituting numerical values, find

$$T_1 - T_2 = \frac{0.05 \text{ m}}{0.7 \text{ W/m} \cdot \text{K}} \left[ 20 \frac{\text{W}}{\text{m}^2 \cdot \text{K}} 100 \text{ K} + 0.8 \times 5.67 \times 10^{-8} \frac{\text{W}}{\text{m}^2 \cdot \text{K}^4} \left[ (400 \text{ K})^4 - (300 \text{ K})^4 \right] \right] = 200 \text{ K}.$$

Since  $T_2 = 400 \text{ K}$ , it follows that  $T_1 = 600 \text{ K}$ . <

(b) Parametric effects may be evaluated by using the IHT *First Law Model* for a *Nonisothermal Plane Wall*. Changes in  $k$  strongly influence conditions for  $k < 20 \text{ W/m} \cdot \text{K}$ , but have a negligible effect for larger values, as  $T_2$  approaches  $T_1$  and the heat fluxes approach the corresponding limiting values

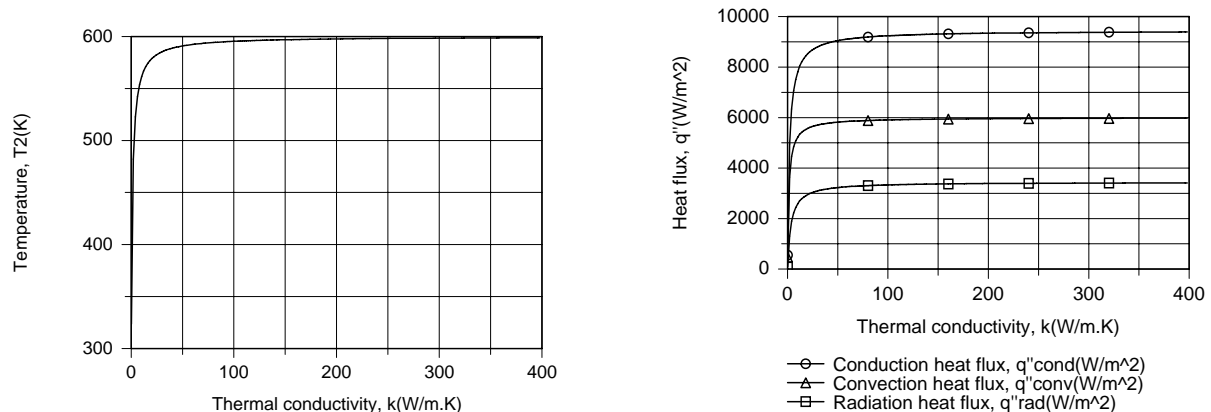

Continued...

### PROBLEM 1.76 (Cont.)

The implication is that, for  $k > 20 \text{ W/m}\cdot\text{K}$ , heat transfer by conduction in the wall is extremely efficient relative to heat transfer by convection and radiation, which become the *limiting* heat transfer processes. Larger fluxes could be obtained by increasing  $\varepsilon$  and  $h$  and/or by decreasing  $T_\infty$  and  $T_{\text{sur}}$ .

With increasing  $h$ , the front surface is cooled more effectively ( $T_2$  decreases), and although  $q''_{\text{rad}}$  decreases, the reduction is exceeded by the increase in  $q''_{\text{conv}}$ . With a reduction in  $T_2$  and fixed values of  $k$  and  $L$ ,  $q''_{\text{cond}}$  must also increase.

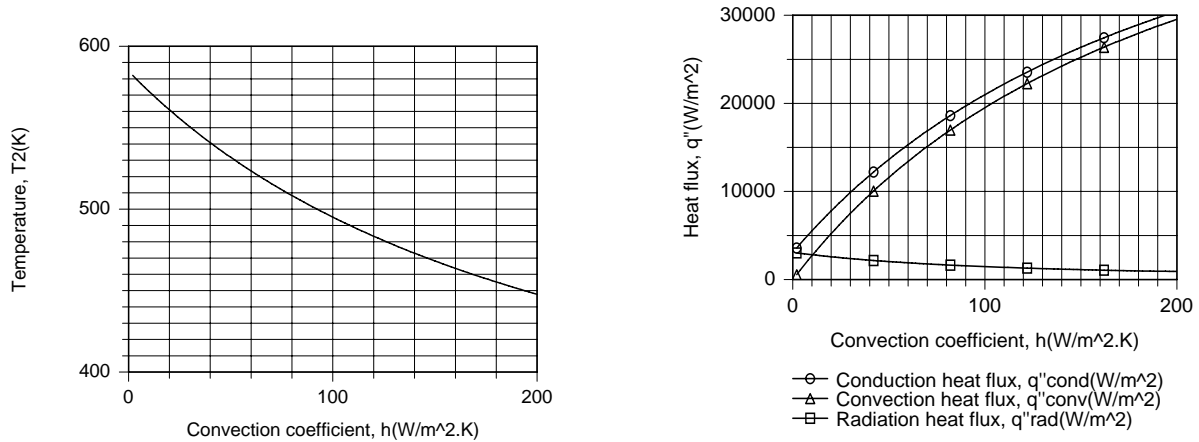

The surface temperature also decreases with increasing  $\varepsilon$ , and the increase in  $q''_{\text{rad}}$  exceeds the reduction in  $q''_{\text{conv}}$ , allowing  $q''_{\text{cond}}$  to increase with  $\varepsilon$ .

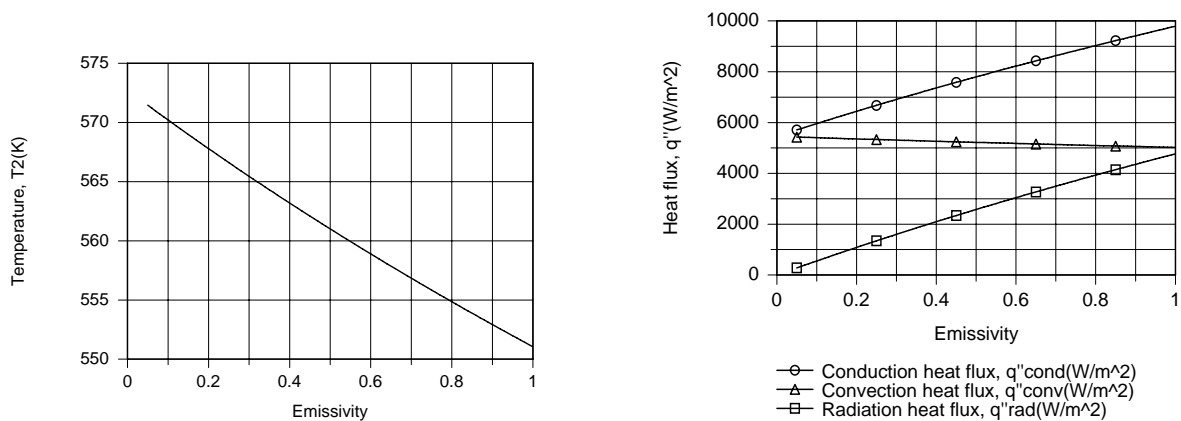

**COMMENTS:** Conservation of energy, of course, dictates that irrespective of the prescribed conditions,  $q''_{\text{cond}} = q''_{\text{conv}} + q''_{\text{rad}}$ .

### PROBLEM 1.77

**KNOWN:** Temperatures at 10 mm and 20 mm from the surface and in the adjoining airflow for a thick stainless steel casting.

**FIND:** Surface convection coefficient,  $h$ .

**SCHEMATIC:**

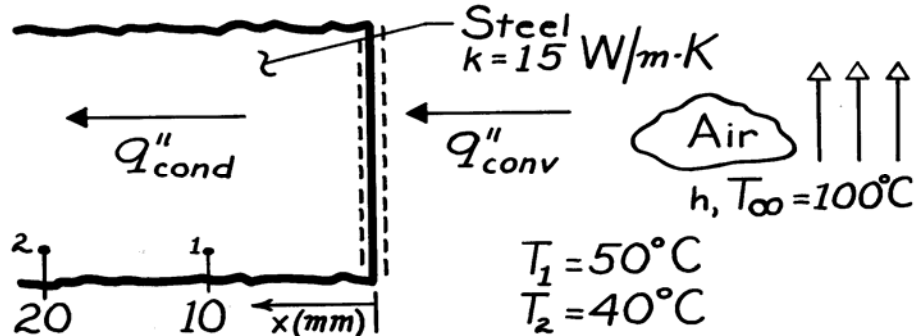

**ASSUMPTIONS:** (1) Steady-state, (2) One-dimensional conduction in the  $x$ -direction, (3) Constant properties, (4) Negligible generation.

**ANALYSIS:** From a surface energy balance, it follows that

$$q''_{\text{cond}} = q''_{\text{conv}}$$

where the convection rate equation has the form

$$q''_{\text{conv}} = h (T_{\infty} - T_0),$$

and  $q''_{\text{cond}}$  can be evaluated from the temperatures prescribed at surfaces 1 and 2. That is, from Fourier's law,

$$q''_{\text{cond}} = k \frac{T_1 - T_2}{x_2 - x_1}$$

$$q''_{\text{cond}} = 15 \frac{\text{W}}{\text{m} \cdot \text{K}} \frac{(50 - 40)^{\circ}\text{C}}{(20 - 10) \times 10^{-3} \text{m}} = 15,000 \text{ W/m}^2.$$

Since the temperature gradient in the solid must be linear for the prescribed conditions, it follows that

$$T_0 = 60^{\circ}\text{C}.$$

Hence, the convection coefficient is

$$h = \frac{q''_{\text{cond}}}{T_{\infty} - T_0}$$

$$h = \frac{15,000 \text{ W/m}^2}{40^{\circ}\text{C}} = 375 \text{ W/m}^2 \cdot \text{K}.$$

<

**COMMENTS:** The accuracy of this procedure for measuring  $h$  depends strongly on the validity of the assumed conditions.

## PROBLEM 1.78

**KNOWN:** Duct wall of prescribed thickness and thermal conductivity experiences prescribed heat flux  $q''_o$  at outer surface and convection at inner surface with known heat transfer coefficient.

**FIND:** (a) Heat flux at outer surface required to maintain inner surface of duct at  $T_i = 85^\circ\text{C}$ , (b) Temperature of outer surface,  $T_o$ . (c) Effect of  $h$  on  $T_o$  and  $q''_o$ .

**SCHEMATIC:**

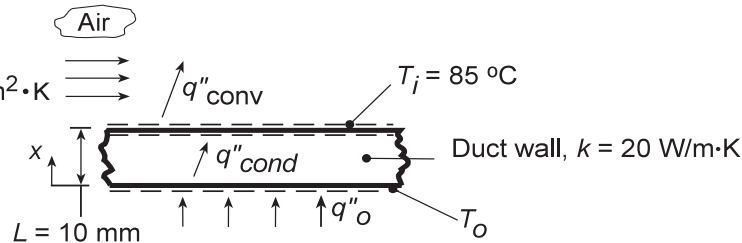

**ASSUMPTIONS:** (1) Steady-state conditions, (2) One-dimensional conduction in wall, (3) Constant properties, (4) Backside of heater perfectly insulated, (5) Negligible radiation.

**ANALYSIS:** (a) By performing an energy balance on the wall, recognize that  $q''_o = q''_{\text{cond}}$ . From an energy balance on the top surface, it follows that  $q''_{\text{cond}} = q''_{\text{conv}} = q''_o$ . Hence, using the convection rate equation,

$$q''_o = q''_{\text{conv}} = h(T_i - T_\infty) = 100 \text{ W/m}^2 \cdot \text{K} (85 - 30)^\circ\text{C} = 5500 \text{ W/m}^2. \quad <$$

(b) Considering the duct wall and applying Fourier's Law,

$$q''_o = k \frac{\Delta T}{\Delta X} = k \frac{T_o - T_i}{L}$$

$$T_o = T_i + \frac{q''_o L}{k} = 85^\circ\text{C} + \frac{5500 \text{ W/m}^2 \times 0.010 \text{ m}}{20 \text{ W/m} \cdot \text{K}} = (85 + 2.8)^\circ\text{C} = 87.8^\circ\text{C}. \quad <$$

(c) For  $T_i = 85^\circ\text{C}$ , the desired results may be obtained by simultaneously solving the energy balance equations

$$q''_o = k \frac{T_o - T_i}{L} \quad \text{and} \quad k \frac{T_o - T_i}{L} = h(T_i - T_\infty)$$

Using the IHT *First Law Model* for a *Nonisothermal Plane Wall*, the following results are obtained.

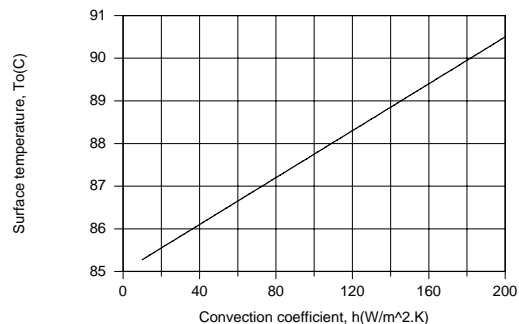
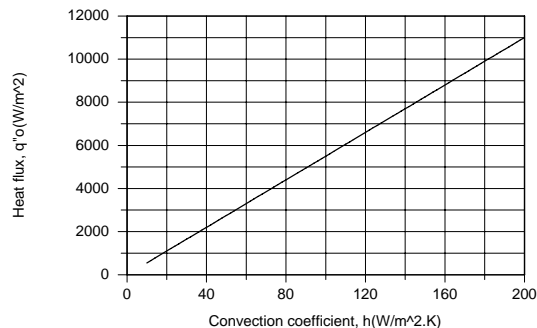

Since  $q''_{\text{conv}}$  increases linearly with increasing  $h$ , the applied heat flux  $q''_o$  and  $q''_{\text{cond}}$  must also increase. An increase in  $q''_{\text{cond}}$ , which, with fixed  $k$ ,  $T_i$  and  $L$ , necessitates an increase in  $T_o$ .

**COMMENTS:** The temperature difference across the wall is small, amounting to a maximum value of  $(T_o - T_i) = 5.5^\circ\text{C}$  for  $h = 200 \text{ W/m}^2 \cdot \text{K}$ . If the wall were thinner ( $L < 10 \text{ mm}$ ) or made from a material with higher conductivity ( $k > 20 \text{ W/m} \cdot \text{K}$ ), this difference would be reduced.

### PROBLEM 1.79

**KNOWN:** Dimensions, average surface temperature and emissivity of heating duct. Duct air inlet temperature and velocity. Temperature of ambient air and surroundings. Convection coefficient.

**FIND:** (a) Heat loss from duct, (b) Air outlet temperature.

**SCHEMATIC:**

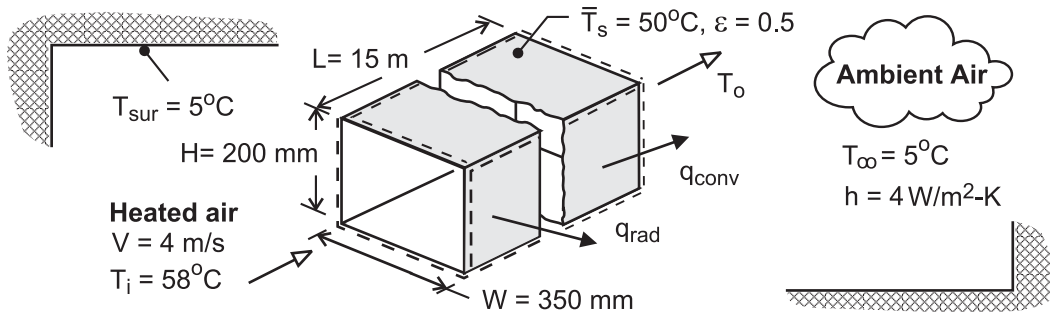

**ASSUMPTIONS:** (1) Steady-state, (2) Constant air properties, (3) Negligible potential and kinetic energy changes of air flow, (4) Radiation exchange between a small surface and a large enclosure.

**ANALYSIS:** (a) Heat transfer from the surface of the duct to the ambient air and the surroundings is given by Eq. (1.10)

$$q = hA_s(T_s - T_\infty) + \varepsilon A_s \sigma (T_s^4 - T_{\text{sur}}^4)$$

where  $A_s = L(2W + 2H) = 15 \text{ m}(0.7 \text{ m} + 0.5 \text{ m}) = 16.5 \text{ m}^2$ . Hence,

$$q = 4 \text{ W/m}^2 \cdot \text{K} \times 16.5 \text{ m}^2 (45^\circ \text{C}) + 0.5 \times 16.5 \text{ m}^2 \times 5.67 \times 10^{-8} \text{ W/m}^2 \cdot \text{K}^4 (323^4 - 278^4) \text{ K}^4$$

$$q = q_{\text{conv}} + q_{\text{rad}} = 2970 \text{ W} + 2298 \text{ W} = 5268 \text{ W} \quad <$$

(b) With  $i = u + pv$ ,  $\dot{W} = 0$  and the third assumption, Eq. (1.12d) yields,

$$\dot{m}(i_i - i_o) = \dot{m}c_p(T_i - T_o) = q$$

where the sign on  $q$  has been reversed to reflect the fact that heat transfer is *from* the system.

With  $\dot{m} = \rho VA_c = 1.10 \text{ kg/m}^3 \times 4 \text{ m/s}(0.35 \text{ m} \times 0.20 \text{ m}) = 0.308 \text{ kg/s}$ , the outlet temperature is

$$T_o = T_i - \frac{q}{\dot{m}c_p} = 58^\circ \text{C} - \frac{5268 \text{ W}}{0.308 \text{ kg/s} \times 1008 \text{ J/kg} \cdot \text{K}} = 41^\circ \text{C} \quad <$$

**COMMENTS:** The temperature drop of the air is large and unacceptable, unless the intent is to use the duct to heat the basement. If not, the duct should be insulated to insure maximum delivery of thermal energy to the intended space(s).

## PROBLEM 1.80

**KNOWN:** Uninsulated pipe of prescribed diameter, emissivity, and surface temperature in a room with fixed wall and air temperatures. See Example 1.2.

**FIND:** (a) Which option to reduce heat loss to the room is more effective: reduce by a factor of two the convection coefficient (from 15 to 7.5 W/m<sup>2</sup>·K) or the emissivity (from 0.8 to 0.4) and (b) Show graphically the heat loss as a function of the convection coefficient for the range 5 ≤ h ≤ 20 W/m<sup>2</sup>·K for emissivities of 0.2, 0.4 and 0.8. Comment on the relative efficacy of reducing heat losses associated with the convection and radiation processes.

**SCHEMATIC:**

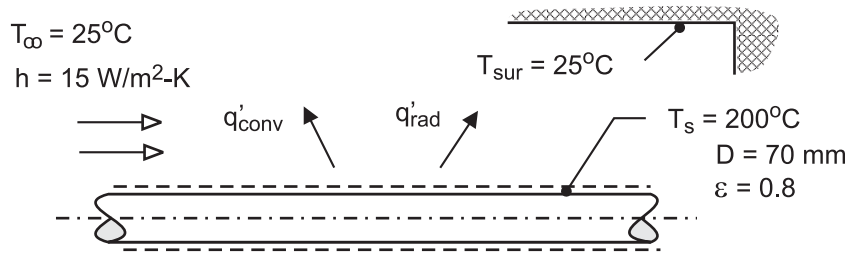

**ASSUMPTIONS:** (1) Steady-state conditions, (2) Radiation exchange between pipe and the room is between a small surface in a much larger enclosure, (3) The surface emissivity and absorptivity are equal, and (4) Restriction of the air flow does not alter the radiation exchange process between the pipe and the room.

**ANALYSIS:** (a) The heat rate from the pipe to the room per unit length is

$$q' = q'/L = q'_{\text{conv}} + q'_{\text{rad}} = h(\pi D)(T_s - T_\infty) + \varepsilon(\pi D)\sigma(T_s^4 - T_{\text{sur}}^4)$$

Substituting numerical values for the two options, the resulting heat rates are calculated and compared with those for the conditions of Example 1.2. We conclude that both options are comparably effective.

Conditions	$h$ (W/m <sup>2</sup> ·K)	$\varepsilon$	$q'$ (W/m)
Base case, Example 1.2	15	0.8	998
Reducing $h$ by factor of 2	7.5	0.8	788
Reducing $\varepsilon$ by factor of 2	15	0.4	709

(b) Using IHT, the heat loss can be calculated as a function of the convection coefficient for selected values of the surface emissivity.

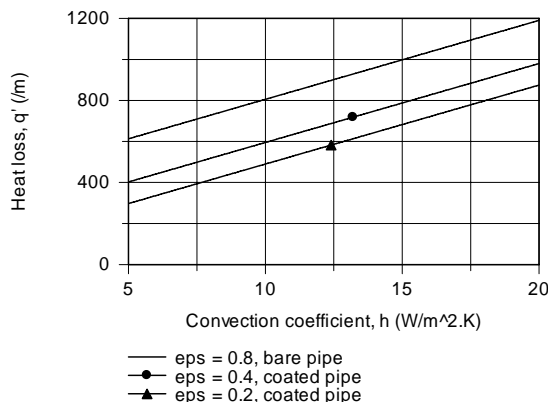

Continued ...



## PROBLEM 1.80 (Cont.)

**COMMENTS:** (1) In Example 1.2, Comment 3, we read that the heat rates by convection and radiation exchange were comparable for the base case conditions (577 vs. 421 W/m). It follows that reducing the key transport parameter ( $h$  or  $\epsilon$ ) by a factor of two yields comparable reductions in the heat loss. Coating the pipe to reduce the emissivity might be the more practical option as it may be difficult to control air movement.

(2) For this pipe size and thermal conditions ( $T_s$  and  $T_\infty$ ), the minimum possible convection coefficient is approximately  $7.5 \text{ W/m}^2 \cdot \text{K}$ , corresponding to free convection heat transfer to quiescent ambient air. Larger values of  $h$  are a consequence of forced air flow conditions.

(3) The Workspace for the IHT program to calculate the heat loss and generate the graph for the heat loss as a function of the convection coefficient for selected emissivities is shown below. It is good practice to provide commentary with the code making your solution logic clear, and to summarize the results.

```
// Heat loss per unit pipe length; rate equation from Ex. 1.2
q' = q'cv + q'rad
q'cv = pi*D*h*(Ts - Tinf)
q'rad = pi*D*eps*sigma*(Ts^4 - Tsur^4)
sigma = 5.67e-8

// Input parameters
D = 0.07
Ts_C = 200      // Representing temperatures in Celsius units using _C subscripting
Ts = Ts_C + 273
Tinf_C = 25
Tinf = Tinf_C + 273
h = 15         // For graph, sweep over range from 5 to 20
Tsur_C = 25
Tsur = Tsur_C + 273
eps = 0.8
//eps = 0.4    // Values of emissivity for parameter study
//eps = 0.2

/* Base case results
Tinf  Ts      Tsur  q'      q'cv    q'rad   D      Tinf_C  Ts_C    Tsur_C
      eps      h      sigma
298   473     298   997.9   577.3   420.6   0.07   25      200     25
      0.8     15     5.67E-8 */
```

## PROBLEM 1.81

**KNOWN:** Conditions associated with surface cooling of plate glass which is initially at 600°C. Maximum allowable temperature gradient in the glass.

**FIND:** Lowest allowable air temperature,  $T_\infty$ .

**SCHEMATIC:**

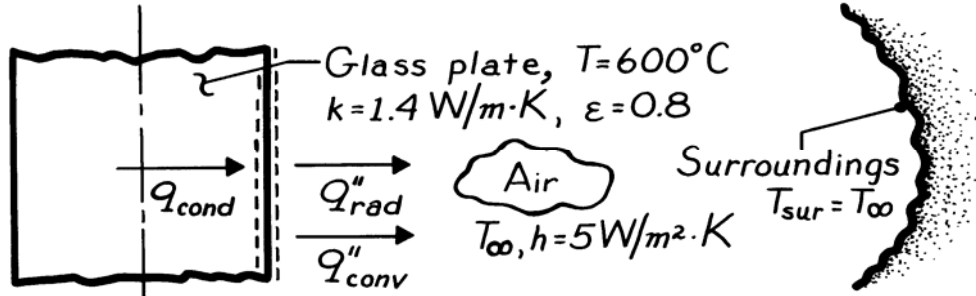

**ASSUMPTIONS:** (1) Surface of glass exchanges radiation with large surroundings at  $T_{\text{sur}} = T_\infty$ , (2) One-dimensional conduction in the  $x$ -direction.

**ANALYSIS:** The maximum temperature gradient will exist at the surface of the glass and at the instant that cooling is initiated. From the surface energy balance, Eq. 1.13, and the rate equations, Eqs. 1.1, 1.3a and 1.7, it follows that

$$-k \frac{dT}{dx} - h(T_s - T_\infty) - \varepsilon\sigma(T_s^4 - T_{\text{sur}}^4) = 0$$

or, with  $(dT/dx)_{\text{max}} = -15^\circ\text{C}/\text{mm} = -15,000^\circ\text{C}/\text{m}$  and  $T_{\text{sur}} = T_\infty$ ,

$$-1.4 \frac{\text{W}}{\text{m} \cdot \text{K}} \left[ -15,000 \frac{^\circ\text{C}}{\text{m}} \right] = 5 \frac{\text{W}}{\text{m}^2 \cdot \text{K}} (873 - T_\infty) \text{K} \\ + 0.8 \times 5.67 \times 10^{-8} \frac{\text{W}}{\text{m}^2 \cdot \text{K}^4} \left[ 873^4 - T_\infty^4 \right] \text{K}^4.$$

$T_\infty$  may be obtained from a trial-and-error solution, from which it follows that, for  $T_\infty = 618\text{K}$ ,

$$21,000 \frac{\text{W}}{\text{m}^2} \approx 1275 \frac{\text{W}}{\text{m}^2} + 19,730 \frac{\text{W}}{\text{m}^2}.$$

Hence the lowest allowable air temperature is

$$T_\infty \approx 618\text{K} = 345^\circ\text{C}.$$

<

**COMMENTS:** (1) Initially, cooling is determined primarily by radiation effects.

(2) For fixed  $T_\infty$ , the surface *temperature gradient* would *decrease* with *increasing* time into the cooling process. Accordingly,  $T_\infty$  could be decreasing with increasing time and still keep within the maximum allowable temperature gradient.

## PROBLEM 1.82

**KNOWN:** Hot-wall oven, in lieu of infrared lamps, with temperature  $T_{\text{sur}} = 200^\circ\text{C}$  for heating a coated plate to the cure temperature. See Example 1.9.

**FIND:** (a) The plate temperature  $T_s$  for prescribed convection conditions and coating emissivity, and (b) Calculate and plot  $T_s$  as a function of  $T_{\text{sur}}$  for the range  $150 \leq T_{\text{sur}} \leq 250^\circ\text{C}$  for ambient air temperatures of 20, 40 and  $60^\circ\text{C}$ ; identify conditions for which acceptable curing temperatures between 100 and  $110^\circ\text{C}$  may be maintained.

**SCHEMATIC:**

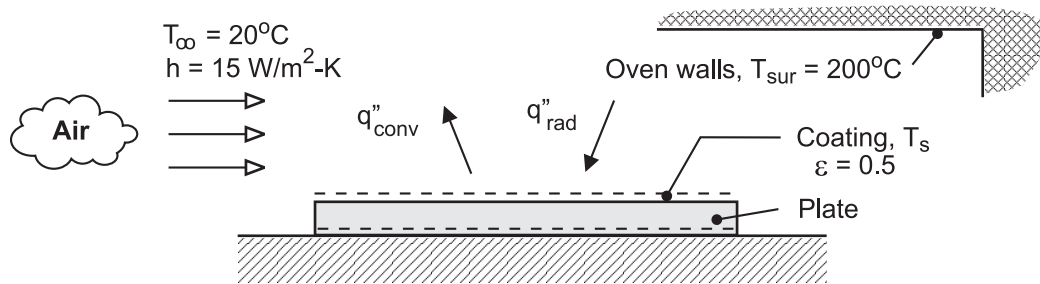

**ASSUMPTIONS:** (1) Steady-state conditions, (2) Negligible heat loss from back surface of plate, (3) Plate is small object in large isothermal surroundings (hot oven walls).

**ANALYSIS:** (a) The temperature of the plate can be determined from an energy balance on the plate, considering radiation exchange with the hot oven walls and convection with the ambient air.

$$\dot{E}_{\text{in}}'' - \dot{E}_{\text{out}}'' = 0 \quad \text{or} \quad q''_{\text{rad}} - q''_{\text{conv}} = 0$$

$$\epsilon\sigma(T_{\text{sur}}^4 - T_s^4) - h(T_s - T_\infty) = 0$$

$$0.5 \times 5.67 \times 10^{-8} \text{ W/m}^2 \cdot \text{K}^4 \left( [200 + 273]^4 - T_s^4 \right) \text{K}^4 - 15 \text{ W/m}^2 \cdot \text{K} (T_s - [20 + 273]) \text{K} = 0$$

$$T_s = 357 \text{ K} = 84^\circ\text{C}$$

<

(b) Using the energy balance relation in the Workspace of IHT, the plate temperature can be calculated and plotted as a function of oven wall temperature for selected ambient air temperatures.

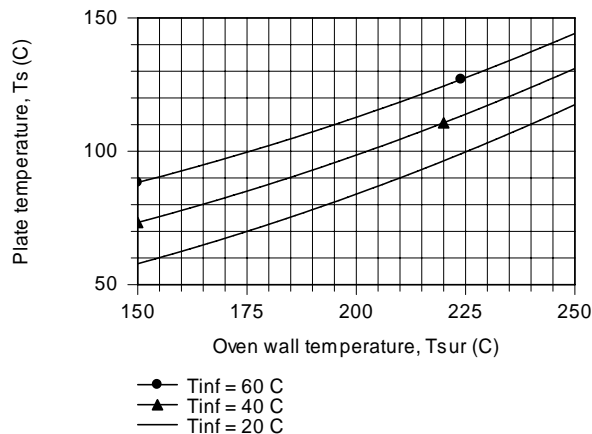

**COMMENTS:** From the graph, acceptable cure temperatures between 100 and  $110^\circ\text{C}$  can be maintained for these conditions: with  $T_\infty = 20^\circ\text{C}$  when  $225 \leq T_{\text{sur}} \leq 240^\circ\text{C}$ ; with  $T_\infty = 40^\circ\text{C}$  when  $205 \leq T_{\text{sur}} \leq 220^\circ\text{C}$ ; and with  $T_\infty = 60^\circ\text{C}$  when  $175 \leq T_{\text{sur}} \leq 195^\circ\text{C}$ .

## PROBLEM 1.83

**KNOWN:** Surface temperature, diameter and emissivity of a hot plate. Temperature of surroundings and ambient air. Expression for convection coefficient.

**FIND:** (a) Operating power for prescribed surface temperature, (b) Effect of surface temperature on power requirement and on the relative contributions of radiation and convection to heat transfer from the surface.

**SCHEMATIC:**

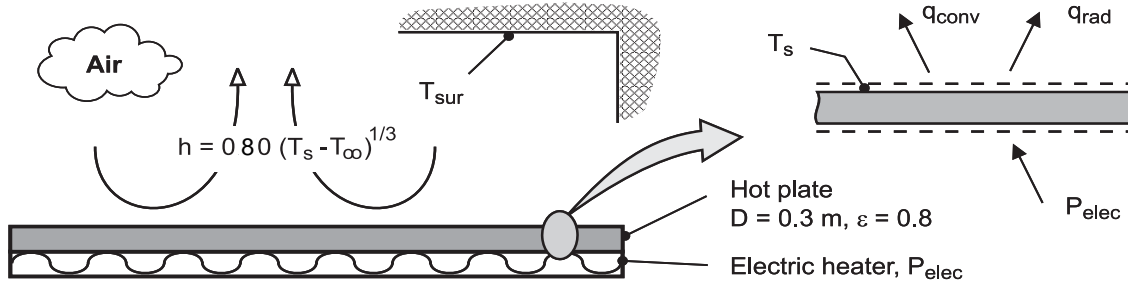

**ASSUMPTIONS:** (1) Plate is of uniform surface temperature, (2) Walls of room are large relative to plate, (3) Negligible heat loss from bottom or sides of plate.

**ANALYSIS:** (a) From an energy balance on the hot plate,  $P_{elec} = q_{conv} + q_{rad} = A_p (q''_{conv} + q''_{rad})$ .

Substituting for the area of the plate and from Eqs. (1.3a) and (1.7), with  $h = 0.80 (T_s - T_{\infty})^{1/3}$ , it follows that

$$P_{elec} = \left( \pi D^2 / 4 \right) \left[ 0.80 (T_s - T_{\infty})^{4/3} + \varepsilon \sigma (T_s^4 - T_{sur}^4) \right]$$

$$P_{elec} = \pi (0.3 \text{ m})^2 / 4 \left[ 0.80 (175)^{4/3} + 0.8 \times 5.67 \times 10^{-8} (473^4 - 298^4) \right] \text{ W/m}^2$$

$$P_{elec} = 0.0707 \text{ m}^2 \left[ 783 \text{ W/m}^2 + 1913 \text{ W/m}^2 \right] = 55.4 \text{ W} + 135.2 \text{ W} = 190.6 \text{ W} \quad <$$

(b) As shown graphically, both the radiation and convection heat rates, and hence the requisite electric power, increase with increasing surface temperature.

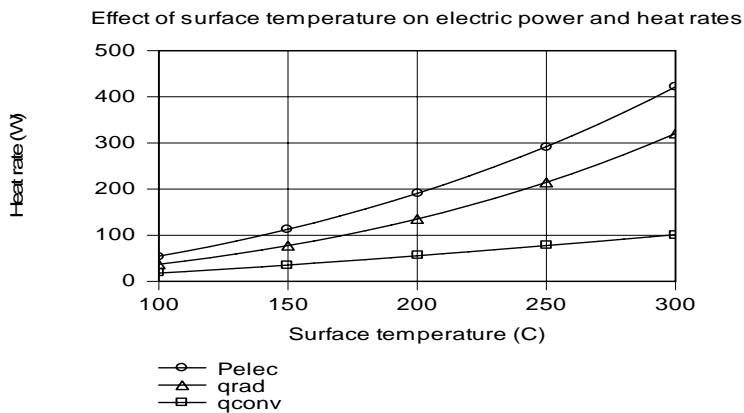

However, because of its dependence on the fourth power of the surface temperature, the increase in radiation is more pronounced. The significant relative effect of radiation is due to the small convection coefficients characteristic of natural convection, with  $3.37 \leq h \leq 5.2 \text{ W/m}^2 \cdot \text{K}$  for  $100 \leq T_s < 300^\circ\text{C}$ .

**COMMENTS:** Radiation losses could be reduced by applying a low emissivity coating to the surface, which would have to maintain its integrity over the range of operating temperatures.

## PROBLEM 1.84

**KNOWN:** Long bus bar of rectangular cross-section and ambient air and surroundings temperatures. Relation for the electrical resistivity as a function of temperature.

**FIND:** (a) Temperature of the bar with a current of 60,000 A, and (b) Compute and plot the operating temperature of the bus bar as a function of the convection coefficient for the range  $10 \leq h \leq 100$   $\text{W/m}^2 \cdot \text{K}$ . Minimum convection coefficient required to maintain a safe-operating temperature below  $120^\circ\text{C}$ . Will increasing the emissivity significantly affect this result?

**SCHEMATIC:**

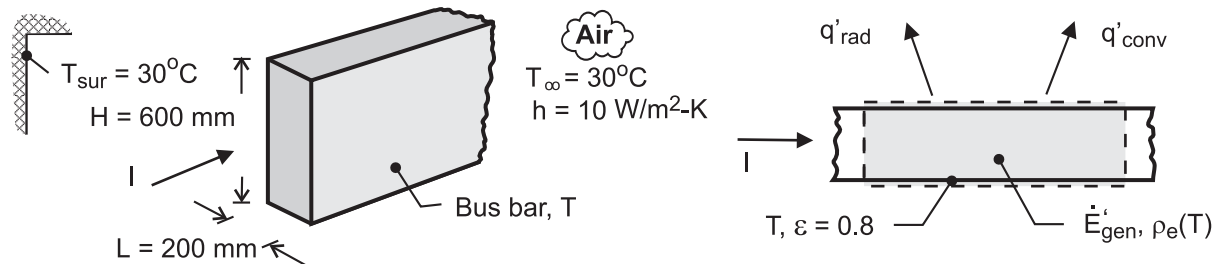

**ASSUMPTIONS:** (1) Steady-state conditions, (2) Bus bar is long, (3) Uniform bus-bar temperature, (3) Radiation exchange between the outer surface of the bus bar and its surroundings is between a small surface and a large enclosure.

**PROPERTIES:** Bus-bar material,  $\rho_e = \rho_{e,o} [1 + \alpha(T - T_o)]$ ,  $\rho_{e,o} = 0.0828 \mu\Omega \cdot \text{m}$ ,  $T_o = 25^\circ\text{C}$ ,  $\alpha = 0.0040 \text{ K}^{-1}$ .

**ANALYSIS:** (a) An energy balance on the bus-bar for a unit length as shown in the schematic above has the form

$$\begin{aligned} \dot{E}'_{\text{in}} - \dot{E}'_{\text{out}} + \dot{E}'_{\text{gen}} &= 0 & -q'_{\text{rad}} - q'_{\text{conv}} + I^2 R'_e &= 0 \\ -\varepsilon P \sigma (T^4 - T_{\text{sur}}^4) - h P (T - T_\infty) + I^2 \rho_e / A_c &= 0 \end{aligned}$$

where  $P = 2(H + W)$ ,  $R'_e = \rho_e / A_c$  and  $A_c = H \times W$ . Substituting numerical values,

$$\begin{aligned} &-0.8 \times 2(0.600 + 0.200) \text{ m} \times 5.67 \times 10^{-8} \text{ W/m}^2 \cdot \text{K}^4 \left( T^4 - [30 + 273]^4 \right) \text{ K}^4 \\ &-10 \text{ W/m}^2 \cdot \text{K} \times 2(0.600 + 0.200) \text{ m} (T - [30 + 273]) \text{ K} \\ &+ (60,000 \text{ A})^2 \left\{ 0.0828 \times 10^{-6} \Omega \cdot \text{m} \left[ 1 + 0.0040 \text{ K}^{-1} (T - [25 + 273]) \text{ K} \right] \right\} / (0.600 \times 0.200) \text{ m}^2 = 0 \end{aligned}$$

Solving for the bus-bar temperature, find  $T = 426 \text{ K} = 153^\circ\text{C}$ . <

(b) Using the energy balance relation in the Workspace of IHT, the bus-bar operating temperature is calculated as a function of the convection coefficient for the range  $10 \leq h \leq 100 \text{ W/m}^2 \cdot \text{K}$ . From this graph we can determine that to maintain a safe operating temperature below  $120^\circ\text{C}$ , the minimum convection coefficient required is

$$h_{\text{min}} = 16 \text{ W/m}^2 \cdot \text{K}. \quad \text{<}$$

Continued ...

## PROBLEM 1.84 (Cont.)

Using the same equations, we can calculate and plot the heat transfer rates by convection and radiation as a function of the bus-bar temperature.

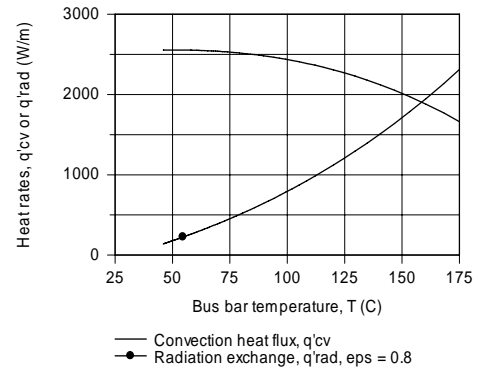
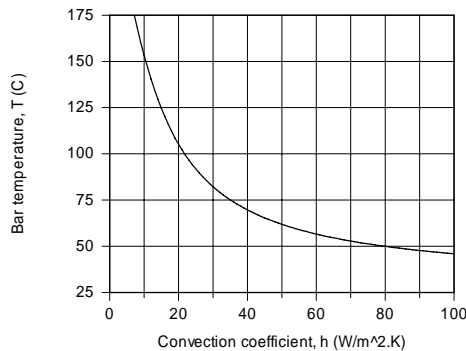

Note that convection is the dominant mode for low bus-bar temperatures; that is, for low current flow. As the bus-bar temperature increases toward the safe-operating limit (120°C), convection and radiation exchange heat transfer rates become comparable. Notice that the relative importance of the radiation exchange rate increases with increasing bus-bar temperature.

**COMMENTS:** (1) It follows from the second graph that increasing the surface emissivity will be only significant at higher temperatures, especially beyond the safe-operating limit.

(2) The Workspace for the IHT program to perform the parametric analysis and generate the graphs is shown below. It is good practice to provide commentary with the code making your solution logic clear, and to summarize the results.

**/\* Results for base case conditions:**

Ts_C	q'cv eps	q'rad h	rhoe	H	I	Tinf_C	Tsur_C	W	alpha
153.3	1973 0.8	1786 10 */	1.253E-7	0.6	6E4	30	30	0.2	0.004

**// Surface energy balance on a per unit length basis**

```

-q'cv - q'rad + Edot'gen = 0
q'cv = h * P * (Ts - Tinf)
P = 2 * (W + H) // perimeter of the bar experiencing surface heat transfer
q'rad = eps * sigma * (Ts^4 - Tsur^4) * P
sigma = 5.67e-8
Edot'gen = I^2 * Re'
Re' = rhoe / Ac
rhoe = rhoeo * ( 1 + alpha * (Ts - Teo))
Ac = W * H
    
```

**// Input parameters**

```

I = 60000
alpha = 0.0040 // temperature coefficient, K^-1; typical value for cast aluminum
rhoeo = 0.0828e-6 // electrical resistivity at the reference temperature, Teo; microhm-m
Teo = 25 + 273 // reference temperature, K
W = 0.200
H = 0.600
Tinf_C = 30
Tinf = Tinf_C + 273
h = 10
eps = 0.8
Tsur_C = 30
Tsur = Tsur_C + 273
Ts_C = Ts - 273
    
```

## PROBLEM 1.85

**KNOWN:** Solar collector designed to heat water operating under prescribed solar irradiation and loss conditions.

**FIND:** (a) Useful heat collected per unit area of the collector,  $q_u''$ , (b) Temperature rise of the water flow,  $T_o - T_i$ , and (c) Collector efficiency.

**SCHEMATIC:**

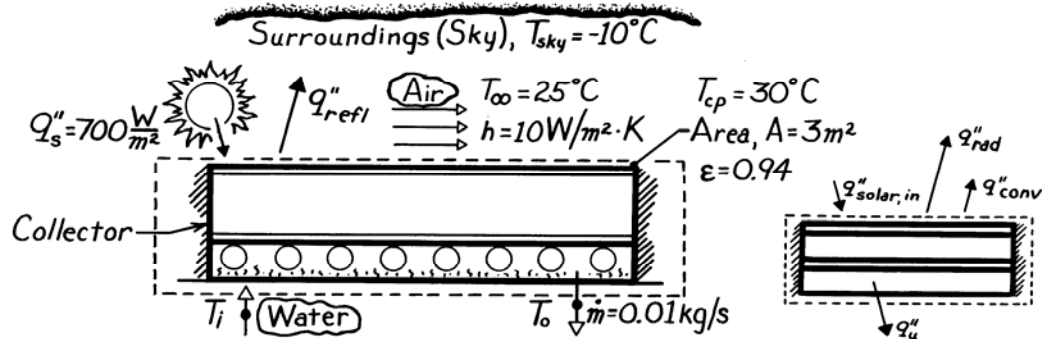

**ASSUMPTIONS:** (1) Steady-state conditions, (2) No heat losses out sides or back of collector, (3) Collector area is small compared to sky surroundings.

**PROPERTIES:** Table A.6, Water (300K):  $c_p = 4179 \text{ J/kg}\cdot\text{K}$ .

**ANALYSIS:** (a) Defining the collector as the control volume and writing the conservation of energy requirement on a per unit area basis, find that

$$\dot{E}_{\text{in}} - \dot{E}_{\text{out}} + \dot{E}_{\text{gen}} = \dot{E}_{\text{st}}$$

Identifying processes as per above right sketch,

$$q_{\text{solar}}'' - q_{\text{rad}}'' - q_{\text{conv}}'' - q_u'' = 0$$

where  $q_{\text{solar}}'' = 0.9 q_s''$ ; that is, 90% of the solar flux is absorbed in the collector (Eq. 1.6). Using the appropriate rate equations, the useful heat rate per unit area is

$$q_u'' = 0.9 q_s'' - \epsilon \sigma (T_{cp}^4 - T_{sky}^4) - h(T_s - T_{\infty})$$

$$q_u'' = 0.9 \times 700 \frac{\text{W}}{\text{m}^2} - 0.94 \times 5.67 \times 10^{-8} \frac{\text{W}}{\text{m}^2 \cdot \text{K}^4} (303^4 - 263^4) \text{K}^4 - 10 \frac{\text{W}}{\text{m}^2 \cdot \text{K}} (30 - 25)^\circ \text{C}$$

$$q_u'' = 630 \text{ W/m}^2 - 194 \text{ W/m}^2 - 50 \text{ W/m}^2 = 386 \text{ W/m}^2. \quad <$$

(b) The total useful heat collected is  $q_u'' \cdot A$ . Defining a control volume about the water tubing, the useful heat causes an enthalpy change of the flowing water. That is,

$$q_u'' \cdot A = \dot{m} c_p (T_i - T_o) \quad \text{or}$$

$$(T_i - T_o) = 386 \text{ W/m}^2 \times 3 \text{ m}^2 / 0.01 \text{ kg/s} \times 4179 \text{ J/kg} \cdot \text{K} = 27.7^\circ \text{C}. \quad <$$

(c) The efficiency is  $\eta = q_u'' / q_s'' = (386 \text{ W/m}^2) / (700 \text{ W/m}^2) = 0.55$  or 55%. <

**COMMENTS:** Note how the sky has been treated as large surroundings at a uniform temperature  $T_{\text{sky}}$ .

### PROBLEM 1.86(a)

**KNOWN:** Solar radiation is incident on an asphalt paving.

**FIND:** Relevant heat transfer processes.

**SCHEMATIC:**

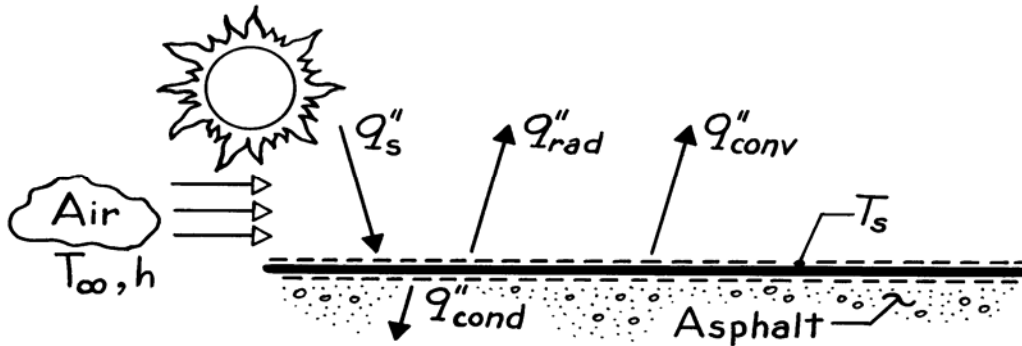

The relevant processes shown on the schematic include:

- $q_s''$  Incident solar radiation, a large portion of which  $q_{s,abs}''$ , is absorbed by the asphalt surface,
- $q_{rad}''$  Radiation emitted by the surface to the air,
- $q_{conv}''$  Convection heat transfer from the surface to the air, and
- $q_{cond}''$  Conduction heat transfer from the surface into the asphalt.

Applying the surface energy balance, Eq. 1.13,

$$q_{s,abs}'' - q_{rad}'' - q_{conv}'' = q_{cond}''.$$

**COMMENTS:** (1)  $q_{cond}''$  and  $q_{conv}''$  could be evaluated from Eqs. 1.1 and 1.3, respectively.

- (2) It has been assumed that the pavement surface temperature is higher than that of the underlying pavement and the air, in which case heat transfer by conduction and convection are from the surface.
- (3) For simplicity, radiation incident on the pavement due to atmospheric emission has been ignored (see Section 12.8 for a discussion). Eq. 1.6 may then be used for the absorbed solar irradiation and Eq. 1.5 may be used to obtain the emitted radiation  $q_{rad}''$ .
- (4) With the rate equations, the energy balance becomes

$$q_{s,abs}'' - \varepsilon \sigma T_s^4 - h(T_s - T_\infty) = -k \left. \frac{dT}{dx} \right|_s.$$



### PROBLEM 1.86(b)

**KNOWN:** Physical mechanism for microwave heating.

**FIND:** Comparison of (a) cooking in a microwave oven with a conventional radiant or convection oven and (b) a microwave clothes dryer with a conventional dryer.

(a) Microwave cooking occurs as a result of volumetric thermal energy generation *throughout* the food, without heating of the food container or the oven wall. Conventional cooking relies on radiant heat transfer from the oven walls and/or convection heat transfer from the air space to the surface of the food and subsequent heat transfer by conduction to the core of the food. Microwave cooking is more efficient and is achieved in less time.

(b) In a microwave dryer, the microwave radiation would heat the water, but not the fabric, directly (the fabric would be heated indirectly by energy transfer from the water). By heating the water, energy would go directly into evaporation, unlike a conventional dryer where the walls and air are first heated electrically or by a gas heater, and thermal energy is subsequently transferred to the wet clothes. The microwave dryer would still require a rotating drum and air flow to remove the water vapor, but is able to operate more efficiently and at lower temperatures.

## PROBLEM 1.86 (c)

**KNOWN:** Water storage tank initial temperature, water initial pressure and temperature, storage tank configuration.

**FIND:** Identify heat transfer processes that will promote freezing of water. Determine effect of insulation thickness. Determine effect of wall thickness and tank material. Determine effect of transfer tubing material. Discuss optimal tank shape, and effect of applying thin aluminum foil to the outside of the tank.

**SCHEMATIC:**

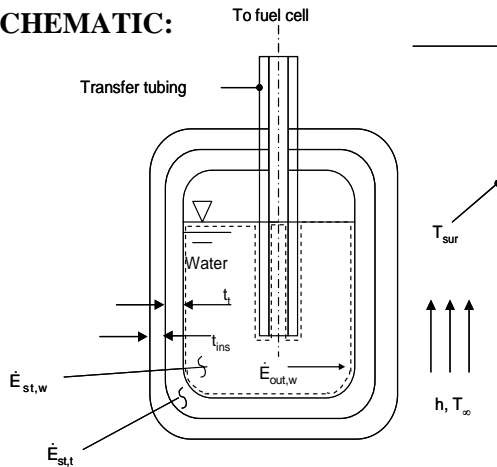

Figure 1 Rapid Response.

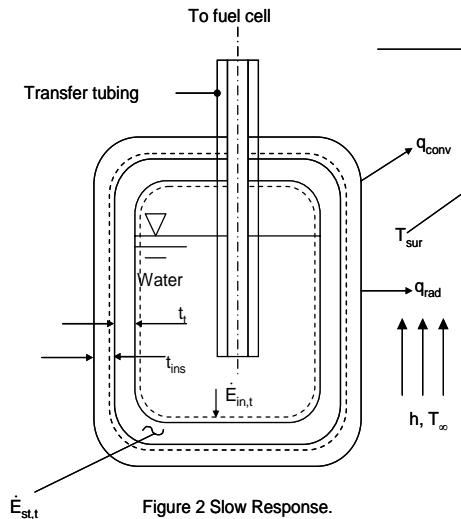

Figure 2 Slow Response.

**ANALYSIS:** The thermal response of the water may be analyzed by dividing the cooling process into two parts.

### Part One. Water and Tank Rapid Response.

We expect the mass of water to be greater than the mass of the tank. From experience, we would not expect the water to completely freeze immediately after filling the tank. Assuming negligible heat transfer through the insulation or transfer tubing during this initial rapid water cooling period, no heat transfer to the air above the water, and assuming isothermal water and tank behavior at any instant in time, an energy balance on a control volume surrounding the water would yield

$$\dot{E}_{st,w} = -\dot{E}_{out,w} \quad (1)$$

An energy balance on a control volume surrounding the tank would yield

$$\dot{E}_{in,t} = \dot{E}_{st,t} \quad (2)$$

$$\text{where } \dot{E}_{out,w} = \dot{E}_{in,t} \quad (3)$$

Combining Eqs. (1) – (3) yields

Continued...

### PROBLEM 1.86 (c) (Cont.)

$$\dot{E}_{st,w} = -\dot{E}_{st,t} = M_w c_{p,w} \cdot (\bar{T} - T_{i,w}) = M_t c_{p,t} \cdot (T_{i,t} - \bar{T}) \quad (4)$$

where  $\bar{T}$  is the average temperature of the water and tank after the initial filling process. For  $M_w c_{p,w} \gg M_t c_{p,t}$ ,  $\bar{T} \approx T_{i,w}$ , thus confirming our expectation.

#### Part Two. Slow Water Cooling.

The heat transfer processes that would promote water freezing include:

- heat transfer through the insulation to the cold air
- heat loss by conduction upward through the wall of the transfer tubing <

As the insulation thickness,  $t_{ins}$ , is increased, Fourier's law indicates that heat losses from the water are decreased, slowing the rate at which the water cools. <

As the tank wall thickness,  $t$ , is increased, the tank wall mass increases. This, along with increasing the tank wall specific heat, will serve to reduce the average temperature,  $\bar{T}$ , to a lower value, as evident by inspecting Eq. (4). This effect, based on the first law of thermodynamics, would decrease the time needed to cool the water to the freezing temperature. As the tank wall thickness is increased, however, heat losses by conduction through the tank wall would decrease as seen by inspection of Fourier's law, slowing the cooling process. As the tank wall thermal conductivity is reduced, this will also decrease the cooling rate of the water. Therefore, the effect of the tank wall thickness could increase *or* decrease the water cooling rate. As the thermal conductivity of the transfer tubing is increased, heat losses from the water upward through the tube wall will increase. This suggests that use of plastic for the transfer tubing would slow the cooling of the water. <

To slow the cooling process, a large water mass to surface area is desired. The mass is proportional to the volume of water in the tank, while the heat loss from the tank by convection to the cold air and radiation to the surroundings is proportional to the surface area of the tank. A spherical tank maximizes the volume-to-area ratio, reducing the rate at which the water temperature drops, and would help prevent freezing. <

Heat losses will occur by convection and radiation at the exposed tank area. The radiation loss, according to Eq. 1.7, is proportional to the emissivity of the surface. Aluminum foil is a low emissivity material, and therefore a wrap of foil would slow the water cooling process. The aluminum foil is very thin and has a high thermal conductivity, therefore by Fourier's law, there would be a very small temperature drop across the thickness of the foil and would not impact the cooling rate. <

### PROBLEM 1.86(d)

**KNOWN:** Double-pane windows with foamed insulation inside or outside. Cold, dry air outside and warm, moist air inside.

**FIND:** Identify heat transfer processes. Which configuration is preferred to avoid condensation?

**SCHEMATIC:**

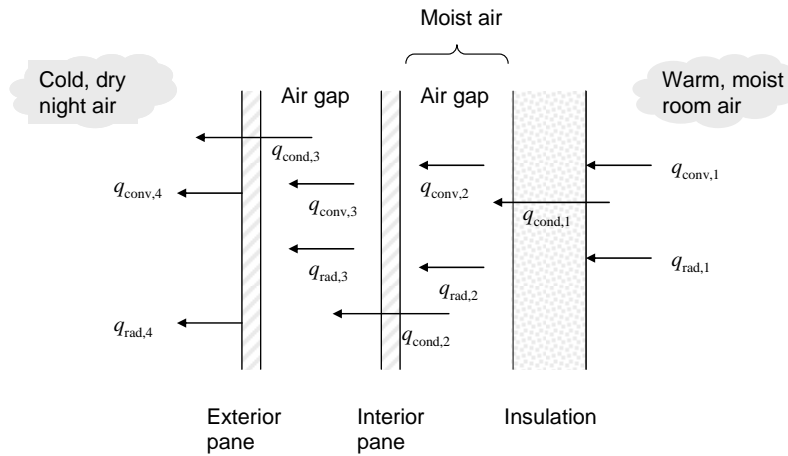

Insulation on inside of window.

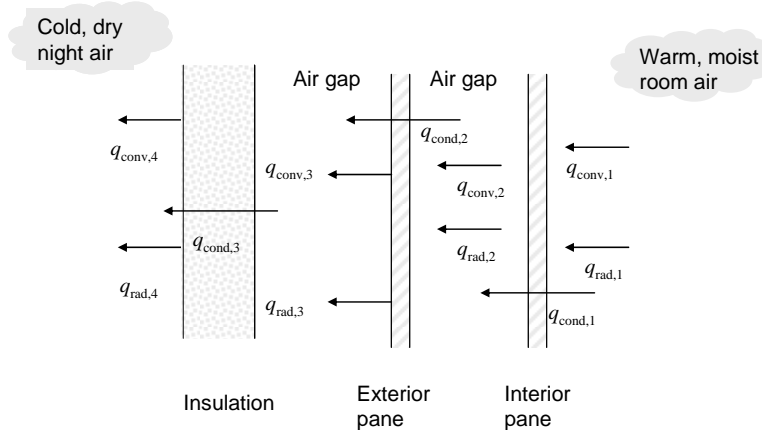

I

Insulation on outside of window.

**ASSUMPTIONS:** (1) Steady-state conditions, (2) One-dimensional heat transfer through window and insulation.

**ANALYSIS:** With the insulation on the inside, heat is transferred from the warm room air to the insulation by convection ( $q_{\text{conv},1}$ ) and from the warm interior surfaces of the room by radiation ( $q_{\text{rad},1}$ ). Heat is then conducted through the insulation ( $q_{\text{cond},1}$ ). From there, heat is transferred across the air gap between the insulation and the window by free convection ( $q_{\text{conv},2}$ ) and radiation ( $q_{\text{rad},2}$ ). Heat is transferred through the first glass pane by conduction ( $q_{\text{cond},2}$ ). Heat transfer across the air gap between the window panes occurs by free convection ( $q_{\text{conv},3}$ ) and radiation ( $q_{\text{rad},3}$ ). Heat is then transferred through the second glass pane by conduction ( $q_{\text{cond},3}$ ). From there, heat is transferred to the cold air by convection ( $q_{\text{conv},4}$ ) and to the cold surroundings by radiation ( $q_{\text{rad},4}$ ). The same mechanisms occur with the insulation on the outside of the window, just in a different order.

Continued...

### PROBLEM 1.86(d) (Cont.)

Condensation may occur on any surface that is exposed to moist air if the surface temperature is below the dewpoint temperature. Condensation causes an additional heat transfer mechanism because when water vapor condenses it releases the enthalpy of vaporization ( $q_{\text{condense}}$ ), which heats the surface on which condensation is occurring. For example, if condensation occurs on the inside surface of the window, this will increase the temperature of that surface and the rate of heat transfer through that window pane. The condensation heat transfer processes are not shown on the schematics.

We know that condensation does not occur on the window's interior pane when there is no insulation in place. If insulation were to be placed on the outside of the window, it will increase the temperature difference between the outside air and the window panes, increasing the window pane temperatures.

Therefore condensation will still not occur. <

If the insulation is placed on the inside of the window, it will increase the temperature difference between the warm room air and the window's interior pane. Both the inner surface of the window and the side of the insulation facing the window may experience temperatures below the dewpoint temperature. Because the insulation is loosely-fitting, moist air infiltrates the gap between the insulation and the inner window pane, and condensation may occur. Liquid water may accumulate and cause water damage. To avoid condensation and associated water damage, the insulation should be placed on the outside of the window. <

**COMMENTS:** (1) The potential water damage is *not* caused by window leakage. Any condensation problem would be exacerbated by adding more insulation to the inside of the window. (2) The potential for condensation damage would be reduced by lowering the humidity in the room, at the risk of increasing discomfort and the potential for illness. (3) Moisture may infiltrate through the insulation. Even tightly-fitting, improperly placed insulation can lead to condensation and water damage. (4) Adding the insulation to the exterior of the window will reduce the possibility of water damage due to condensation, but it cannot be easily removed to enjoy a bright winter day.

### PROBLEM 1.86(e)

**KNOWN:** Geometry of a composite insulation consisting of a honeycomb core.

**FIND:** Relevant heat transfer processes.

**SCHEMATIC:**

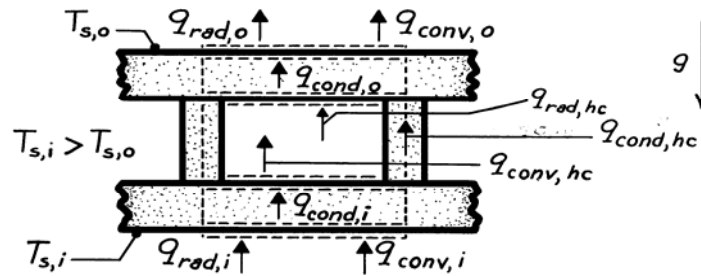

The above schematic represents the cross section of a single honeycomb cell and surface slabs. Assumed direction of gravity field is downward. Assuming that the bottom (inner) surface temperature exceeds the top (outer) surface temperature ( $T_{s,i} > T_{s,o}$ ), heat transfer is in the direction shown.

Heat may be transferred to the inner surface by convection and radiation, whereupon it is transferred through the composite by

- $q_{\text{cond},i}$  Conduction through the inner solid slab,
- $q_{\text{conv},hc}$  Free convection through the cellular airspace,
- $q_{\text{cond},hc}$  Conduction through the honeycomb wall,
- $q_{\text{rad},hc}$  Radiation between the honeycomb surfaces, and
- $q_{\text{cond},o}$  Conduction through the outer solid slab.

Heat may then be transferred from the outer surface by convection and radiation. Note that for a single cell under steady state conditions,

$$q_{\text{rad},i} + q_{\text{conv},i} = q_{\text{cond},i} = q_{\text{conv},hc} + q_{\text{cond},hc}$$

$$+ q_{\text{rad},hc} = q_{\text{cond},o} = q_{\text{rad},o} + q_{\text{conv},o}$$

**COMMENTS:** Performance would be enhanced by using materials of low thermal conductivity,  $k$ , and emissivity,  $\epsilon$ . Evacuating the airspace would enhance performance by eliminating heat transfer due to free convection.

### PROBLEM 1.86(f)

**KNOWN:** A thermocouple junction is used, with or without a radiation shield, to measure the temperature of a gas flowing through a channel. The wall of the channel is at a temperature much less than that of the gas.

**FIND:** (a) Relevant heat transfer processes, (b) Temperature of junction relative to that of gas, (c) Effect of radiation shield.

**SCHEMATIC:**

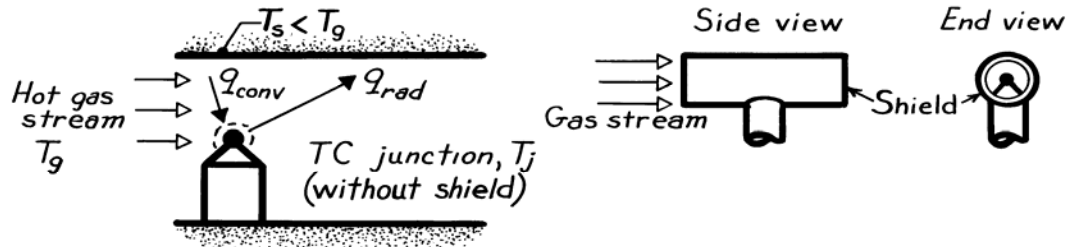

**ASSUMPTIONS:** (1) Junction is small relative to channel walls, (2) Steady-state conditions, (3) Negligible heat transfer by conduction through the thermocouple leads.

**ANALYSIS:** (a) The relevant heat transfer processes are:

$q_{rad}$  Net radiation transfer from the junction to the walls, and

$q_{conv}$  Convection transfer from the gas to the junction.

(b) From a surface energy balance on the junction,

$$q_{conv} = q_{rad}$$

or from Eqs. 1.3a and 1.7,

$$h A (T_g - T_j) = \varepsilon A \sigma (T_j^4 - T_s^4).$$

To satisfy this equality, it follows that

$$T_s < T_j < T_g.$$

That is, the junction assumes a temperature between that of the channel wall and the gas, thereby sensing a temperature which is less than that of the gas.

(c) The measurement error  $(T_g - T_j)$  is reduced by using a radiation shield as shown in the schematic. The junction now exchanges radiation with the shield, whose temperature must exceed that of the channel wall. The radiation loss from the junction is therefore reduced, and its temperature more closely approaches that of the gas.

### PROBLEM 1.86(g)

**KNOWN:** Fireplace cavity is separated from room air by two glass plates, open at both ends.

**FIND:** Relevant heat transfer processes.

**SCHEMATIC:**

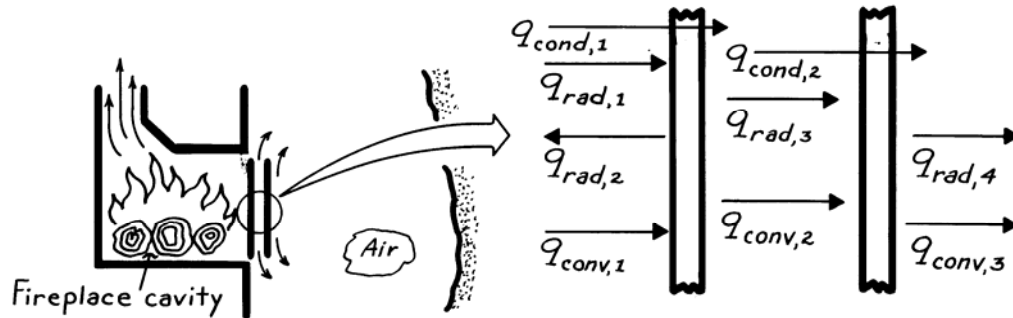

The relevant heat transfer processes associated with the double-glazed, glass fire screen are:

- $q_{rad,1}$  Radiation from flames and cavity wall, portions of which are absorbed and transmitted by the two panes,
- $q_{rad,2}$  Emission from inner surface of inner pane to cavity,
- $q_{rad,3}$  Net radiation exchange between outer surface of inner pane and inner surface of outer pane,
- $q_{rad,4}$  Net radiation exchange between outer surface of outer pane and walls of room,
- $q_{conv,1}$  Convection between cavity gases and inner pane,
- $q_{conv,2}$  Convection across air space between panes,
- $q_{conv,3}$  Convection from outer surface to room air,
- $q_{cond,1}$  Conduction across inner pane, and
- $q_{cond,2}$  Conduction across outer pane.

**COMMENTS:** (1) Much of the luminous portion of the flame radiation is transmitted to the room interior.

(2) All convection processes are buoyancy driven (free convection).



## PROBLEM 1.86(h)

**KNOWN:** Thermocouple junction held in small hole in solid material by epoxy. Solid is hotter than surroundings.

**FIND:** Identify heat transfer processes. Will thermocouple junction sense temperature less than, equal to, or greater than solid temperature? How will thermal conductivity of epoxy affect junction temperature?

**SCHEMATIC:**

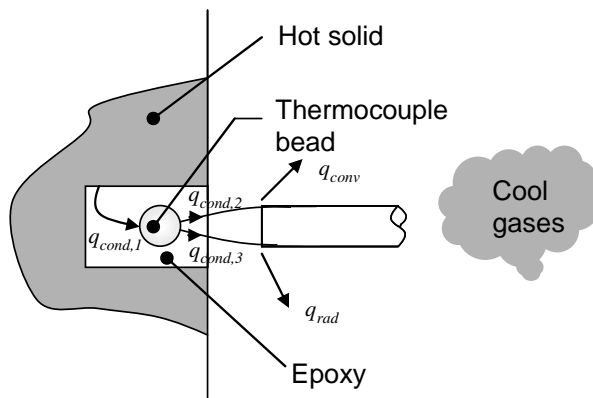

**ASSUMPTIONS:** (1) Steady-state conditions.

**ANALYSIS:** Heat is transferred from the solid material through the epoxy to the thermocouple junction by conduction,  $q_{cond,1}$ . Heat is also transferred from the junction along the thermocouple wires and their sheathing by conduction ( $q_{cond,2}$  and  $q_{cond,3}$ ), and from there to the surroundings by convection ( $q_{conv}$ ) and radiation ( $q_{rad}$ ). Thus, the junction is heated by the solid and cooled by the surroundings, and its temperature will be between the solid temperature and the temperature of the cool gases.

The junction temperature will be less than the solid temperature. <

Under steady-state conditions, the rate at which heat is transferred to the junction from the solid material must equal the rate at which heat is transferred from the junction to the cool gases and surroundings. If we think of this heat transfer rate as fixed, then Equation 1.2 shows that a higher thermal conductivity for the epoxy will result in a smaller temperature difference across the epoxy. This leads to the thermocouple sensing a temperature that is closer to the solid temperature.

Higher thermal conductivity of epoxy leads to the thermocouple temperature being closer to the solid temperature. <

**COMMENTS:** (1) High thermal conductivity epoxies are formulated specifically for the purpose of affixing thermocouples. Their thermal conductivity is increased by adding small particles of high thermal conductivity materials such as silver. (2) Different types of thermocouple wires are available. To further reduce temperature differences between the solid and the thermocouple junction, small diameter thermocouple wires of relatively low thermal conductivity, such as chromel and alumel, are preferred. (3) Because thermocouple wires are made of different metals, in general  $q_{cond,2} \neq q_{cond,3}$ .

**PROBLEM 1.87(a)**

**KNOWN:** Room air is separated from ambient air by one or two glass panes.

**FIND:** Relevant heat transfer processes.

**SCHEMATIC:**

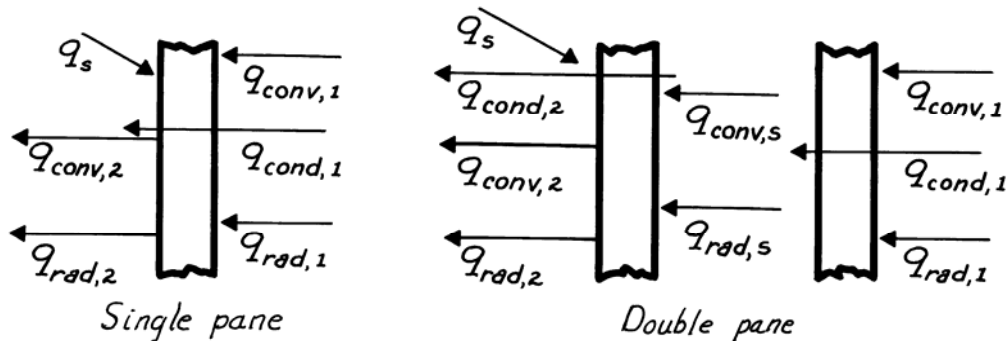

The relevant processes associated with single (above left schematic) and double (above right schematic) glass panes include.

- $q_{conv,1}$  Convection from room air to inner surface of first pane,
- $q_{rad,1}$  Net radiation exchange between room walls and inner surface of first pane,
- $q_{cond,1}$  Conduction through first pane,
- $q_{conv,s}$  Convection across airspace between panes,
- $q_{rad,s}$  Net radiation exchange between outer surface of first pane and inner surface of second pane (across airspace),
- $q_{cond,2}$  Conduction through a second pane,
- $q_{conv,2}$  Convection from outer surface of single (or second) pane to ambient air,
- $q_{rad,2}$  Net radiation exchange between outer surface of single (or second) pane and surroundings such as the ground, and
- $q_s$  Incident solar radiation during day; fraction transmitted to room is smaller for double pane.

**COMMENTS:** Heat loss from the room is significantly reduced by the double pane construction.

### PROBLEM 1.87(b)

**KNOWN:** Configuration of a flat plate solar collector.

**FIND:** Relevant heat transfer processes with and without a cover plate.

**SCHEMATIC:**

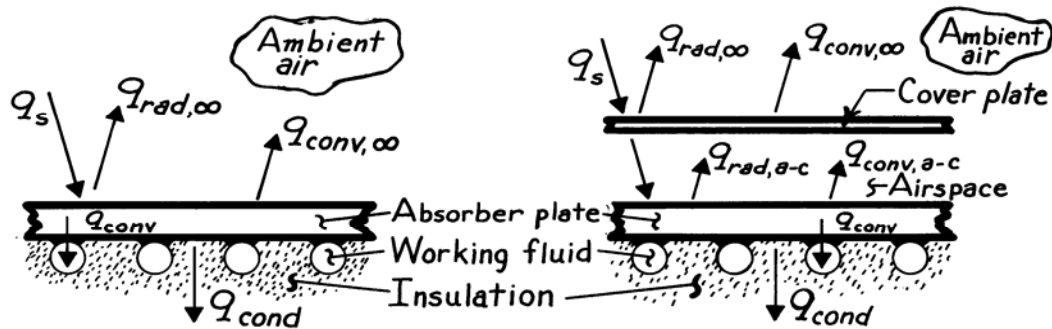

The relevant processes without (above left schematic) and with (above right schematic) include:

- $q_s$  Incident solar radiation, a large portion of which is absorbed by the absorber plate. Reduced with use of cover plate (primarily due to reflection off cover plate).
- $q_{rad,\infty}$  Net radiation exchange between absorber plate or cover plate and surroundings,
- $q_{conv,\infty}$  Convection from absorber plate or cover plate to ambient air,
- $q_{rad,a-c}$  Net radiation exchange between absorber and cover plates,
- $q_{conv,a-c}$  Convection heat transfer across airspace between absorber and cover plates,
- $q_{cond}$  Conduction through insulation, and
- $q_{conv}$  Convection to working fluid.

**COMMENTS:** The cover plate acts to significantly reduce heat losses by convection and radiation from the absorber plate to the surroundings.

### PROBLEM 1.87(c)

**KNOWN:** Configuration of a solar collector used to heat air for agricultural applications.

**FIND:** Relevant heat transfer processes.

**SCHEMATIC:**

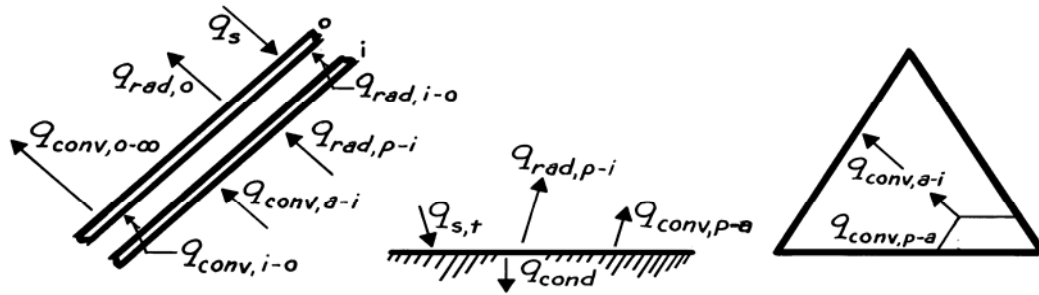

Assume the temperature of the absorber plates exceeds the ambient air temperature. At the *cover plates*, the relevant processes are:

- $q_{\text{conv},a-i}$  Convection from inside air to inner surface,
- $q_{\text{rad},p-i}$  Net radiation transfer from absorber plates to inner surface,
- $q_{\text{conv},i-o}$  Convection across airspace between covers,
- $q_{\text{rad},i-o}$  Net radiation transfer from inner to outer cover,
- $q_{\text{conv},o-\infty}$  Convection from outer cover to ambient air,
- $q_{\text{rad},o}$  Net radiation transfer from outer cover to surroundings, and
- $q_s$  Incident solar radiation.

Additional processes relevant to the *absorber plates* and *airspace* are:

- $q_{s,t}$  Solar radiation transmitted by cover plates,
- $q_{\text{conv},p-a}$  Convection from absorber plates to inside air, and
- $q_{\text{cond}}$  Conduction through insulation.

### PROBLEM 1.87(d)

**KNOWN:** Features of an evacuated tube solar collector.

**FIND:** Relevant heat transfer processes for one of the tubes.

**SCHEMATIC:**

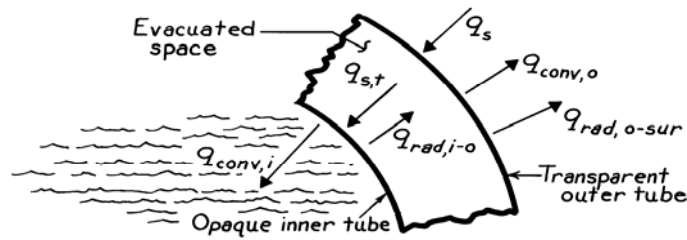

The relevant heat transfer processes for one of the evacuated tube solar collectors includes:

- $q_s$  Incident solar radiation including contribution due to reflection off panel (most is transmitted),
- $q_{conv,o}$  Convection heat transfer from outer surface to ambient air,
- $q_{rad,o-sur}$  Net rate of radiation heat exchange between outer surface of outer tube and the surroundings, including the panel,
- $q_{s,t}$  Solar radiation transmitted through outer tube and incident on inner tube (most is absorbed),
- $q_{rad,i-o}$  Net rate of radiation heat exchange between outer surface of inner tube and inner surface of outer tube, and
- $q_{conv,i}$  Convection heat transfer to working fluid.

There is also conduction heat transfer through the inner and outer tube walls. If the walls are thin, the temperature drop across the walls will be small.

## PROBLEM 2.1

**KNOWN:** Steady-state, one-dimensional heat conduction through an axisymmetric shape.

**FIND:** Sketch temperature distribution and explain shape of curve.

**SCHEMATIC:**

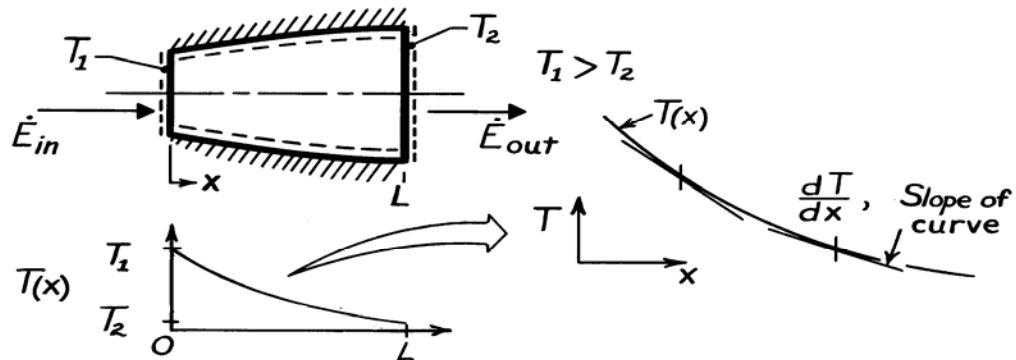

**ASSUMPTIONS:** (1) Steady-state, one-dimensional conduction, (2) Constant properties, (3) No internal heat generation.

**ANALYSIS:** Performing an energy balance on the object according to Eq. 1.12c,  $\dot{E}_{in} - \dot{E}_{out} = 0$ , it follows that

$$\dot{E}_{in} - \dot{E}_{out} = q_x$$

and that  $q_x \neq q_x(x)$ . That is, the heat rate within the object is everywhere constant. From Fourier's law,

$$q_x = -kA_x \frac{dT}{dx},$$

and since  $q_x$  and  $k$  are both constants, it follows that

$$A_x \frac{dT}{dx} = \text{Constant.}$$

That is, the product of the cross-sectional area normal to the heat rate and temperature gradient remains a constant and independent of distance  $x$ . It follows that since  $A_x$  increases with  $x$ , then  $dT/dx$  must decrease with increasing  $x$ . Hence, the temperature distribution appears as shown above.

**COMMENTS:** (1) Be sure to recognize that  $dT/dx$  is the slope of the temperature distribution. (2) What would the distribution be when  $T_2 > T_1$ ? (3) How does the heat flux,  $q_x''$ , vary with distance?

## PROBLEM 2.2

**KNOWN:** Axisymmetric object with varying cross-sectional area and different temperatures at its two ends, insulated on its sides.

**FIND:** Shapes of heat flux distribution and temperature distribution.

**SCHEMATIC:**

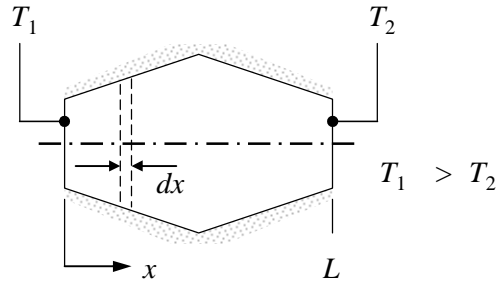

**ASSUMPTIONS:** (1) Steady-state, (2) One-dimensional conduction, (3) Constant properties, (4) Adiabatic sides, (5) No internal heat generation. (6) Surface temperatures  $T_1$  and  $T_2$  are fixed.

**ANALYSIS:** For the prescribed conditions, it follows from conservation of energy, Eq. 1.12c, that for a differential control volume,  $\dot{E}_{in} = \dot{E}_{out}$  or  $q_x = q_{x+dx}$ . Hence

$q_x$  is independent of  $x$ .

Therefore

$$q_x = q_x'' A_c = \text{constant} \quad (1)$$

where  $A_c$  is the cross-sectional area perpendicular to the  $x$ -direction. Therefore the heat flux must be inversely proportional to the cross-sectional area. The radius of the object first increases and then decreases linearly with  $x$ , so the cross-sectional area increases and then decreases as  $x^2$ . The resulting heat flux distribution is sketched below.

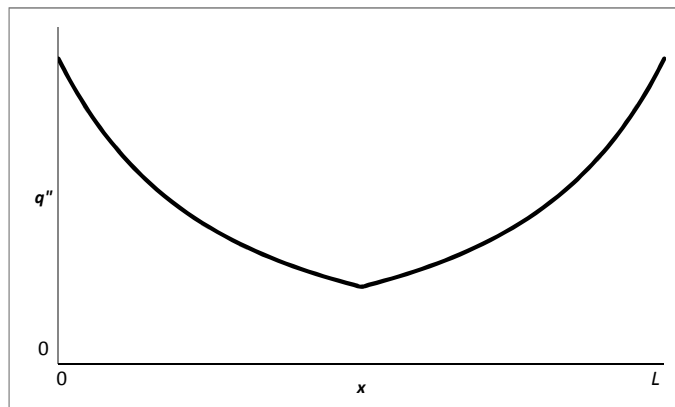

Continued...

### PROBLEM 2.2 (Cont.)

To find the temperature distribution, we can use Fourier's law:

$$q_x'' = -k \frac{dT}{dx} \quad (2)$$

Therefore the temperature gradient is negative and its magnitude is proportional to the heat flux. The temperature decreases most rapidly where the heat flux is largest and more slowly where the heat flux is smaller.

Based on the heat flux plot above we can prepare the sketch of the temperature distribution below.

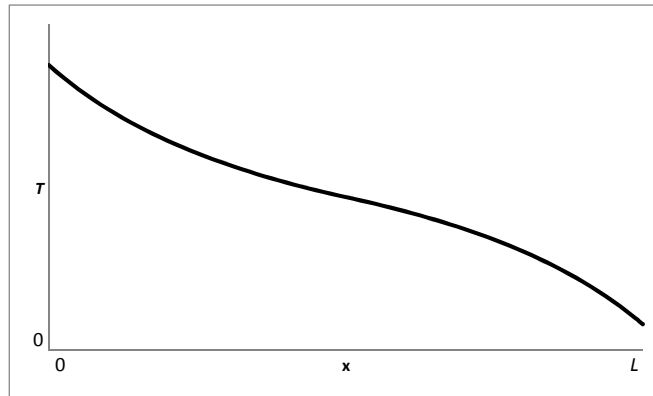

The temperature distribution is independent of the thermal conductivity. The heat rate and local heat fluxes are both proportional to the thermal conductivity of the material.

<

**COMMENTS:** If the heat rate was fixed the temperature difference,  $T_1 - T_2$ , would be inversely proportional to the thermal conductivity. The temperature distribution would be of the same shape, but local temperatures  $T(x)$  would vary as the thermal conductivity is adjusted.



### PROBLEM 2.3

**KNOWN:** Hot water pipe covered with thick layer of insulation.

**FIND:** Sketch temperature distribution and give brief explanation to justify shape.

**SCHEMATIC:**

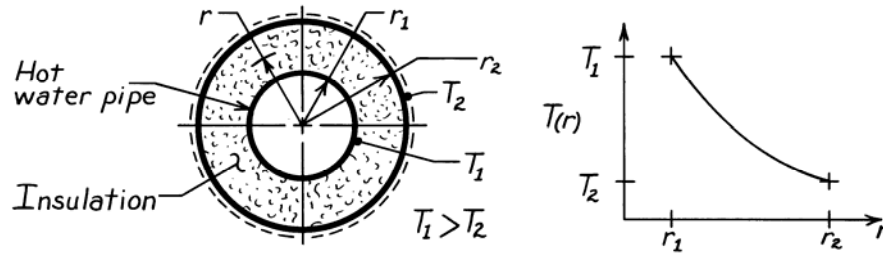

**ASSUMPTIONS:** (1) Steady-state conditions, (2) One-dimensional (radial) conduction, (3) No internal heat generation, (4) Insulation has uniform properties independent of temperature and position.

**ANALYSIS:** Fourier's law, Eq. 2.1, for this one-dimensional (cylindrical) radial system has the form

$$q_r = -kA_r \frac{dT}{dr} = -k(2\pi r\ell) \frac{dT}{dr}$$

where  $A_r = 2\pi r\ell$  and  $\ell$  is the axial length of the pipe-insulation system. Recognize that for steady-state conditions with no internal heat generation, an energy balance on the system requires

$\dot{E}_{in} = \dot{E}_{out}$  since  $\dot{E}_g = \dot{E}_{st} = 0$ . Hence

$$q_r = \text{Constant.}$$

That is,  $q_r$  is independent of radius ( $r$ ). Since the thermal conductivity is also constant, it follows that

$$r \left[ \frac{dT}{dr} \right] = \text{Constant.}$$

This relation requires that the product of the radial temperature gradient,  $dT/dr$ , and the radius,  $r$ , remains constant throughout the insulation. For our situation, the temperature distribution must appear as shown in the sketch.

**COMMENTS:** (1) Note that, while  $q_r$  is a constant and independent of  $r$ ,  $q_r''$  is not a constant. How does  $q_r''(r)$  vary with  $r$ ? (2) Recognize that the radial temperature gradient,  $dT/dr$ , decreases with increasing radius.

## PROBLEM 2.4

**KNOWN:** A spherical shell with prescribed geometry and surface temperatures.

**FIND:** Sketch temperature distribution and explain shape of the curve.

**SCHEMATIC:**

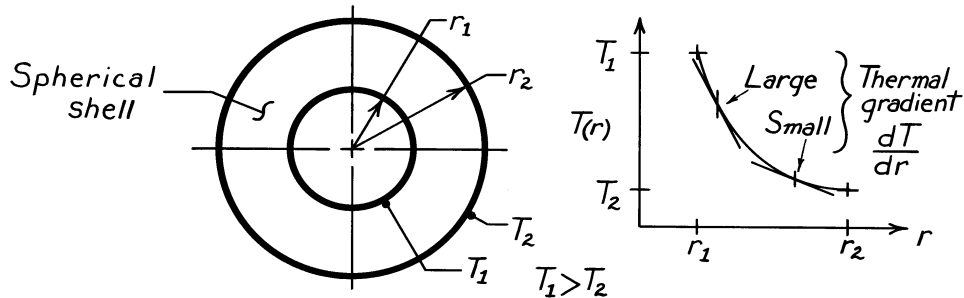

**ASSUMPTIONS:** (1) Steady-state conditions, (2) One-dimensional conduction in radial (spherical coordinates) direction, (3) No internal generation, (4) Constant properties.

**ANALYSIS:** Fourier's law, Eq. 2.1, for this one-dimensional, radial (spherical coordinate) system has the form

$$q_r = -k A_r \frac{dT}{dr} = -k (4\pi r^2) \frac{dT}{dr}$$

where  $A_r$  is the surface area of a sphere. For steady-state conditions, an energy balance on the system yields  $\dot{E}_{in} = \dot{E}_{out}$ , since  $\dot{E}_g = \dot{E}_{st} = 0$ . Hence,

$$q_{in} = q_{out} = q_r \neq q_r(r).$$

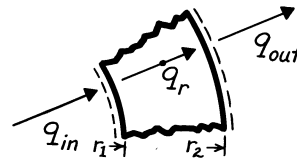

That is,  $q_r$  is a constant, independent of the radial coordinate. Since the thermal conductivity is constant, it follows that

$$r^2 \left[ \frac{dT}{dr} \right] = \text{Constant.}$$

This relation requires that the product of the radial temperature gradient,  $dT/dr$ , and the radius squared,  $r^2$ , remains constant throughout the shell. Hence, the temperature distribution appears as shown in the sketch.

**COMMENTS:** Note that, for the above conditions,  $q_r \neq q_r(r)$ ; that is,  $q_r$  is everywhere constant. How does  $q_r''$  vary as a function of radius?

### PROBLEM 2.5

**KNOWN:** Symmetric shape with prescribed variation in cross-sectional area, temperature distribution and heat rate.

**FIND:** Expression for the thermal conductivity,  $k$ .

**SCHEMATIC:**

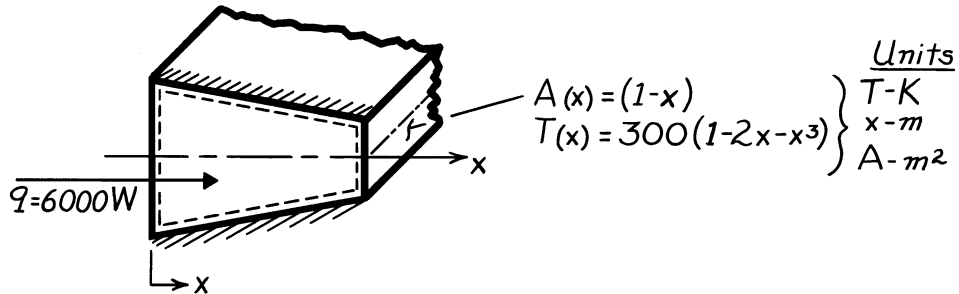

**ASSUMPTIONS:** (1) Steady-state conditions, (2) One-dimensional conduction in  $x$ -direction, (3) No internal heat generation.

**ANALYSIS:** Applying the energy balance, Eq. 1.12c, to the system, it follows that, since  $\dot{E}_{in} = \dot{E}_{out}$ ,

$$q_x = \text{Constant} \neq f(x).$$

Using Fourier's law, Eq. 2.1, with appropriate expressions for  $A_x$  and  $T$ , yields

$$q_x = -k A_x \frac{dT}{dx}$$

$$6000 \text{ W} = -k \cdot (1-x) \text{ m}^2 \cdot \frac{d}{dx} \left[ 300(1-2x-x^3) \right] \frac{\text{K}}{\text{m}}.$$

Solving for  $k$  and recognizing its units are  $\text{W/m}\cdot\text{K}$ ,

$$k = \frac{-6000}{(1-x) \left[ 300(-2-3x^2) \right]} = \frac{20}{(1-x)(2+3x^2)}.$$

**COMMENTS:** (1) At  $x = 0$ ,  $k = 10 \text{ W/m}\cdot\text{K}$  and  $k \rightarrow \infty$  as  $x \rightarrow 1$ . (2) Recognize that the 1-D assumption is an approximation which becomes more inappropriate as the area change with  $x$ , and hence two-dimensional effects, become more pronounced.

## PROBLEM 2.6

**KNOWN:** Rod consisting of two materials with same lengths. Ratio of thermal conductivities.

**FIND:** Sketch temperature and heat flux distributions.

**SCHEMATIC:**

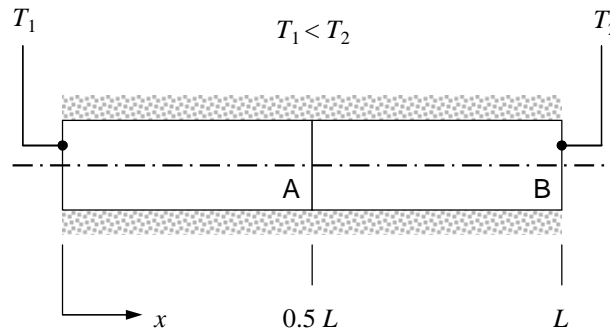

**ASSUMPTIONS:** (1) Steady-state conditions, (2) One-dimensional conduction, (3) Constant properties, (3) No internal generation.

**ANALYSIS:** From Equation 2.19 for steady-state, one-dimensional conduction with constant properties and no internal heat generation,

$$\frac{\partial}{\partial x} \left( k \frac{\partial T}{\partial x} \right) = 0 \quad \text{or} \quad \frac{\partial q_x''}{\partial x} = 0$$

From these equations we know that heat flux is constant and the temperature gradient is inversely proportional to  $k$ . Thus, with  $k_A = 0.5k_B$ , we can sketch the temperature and heat flux distributions as shown below:

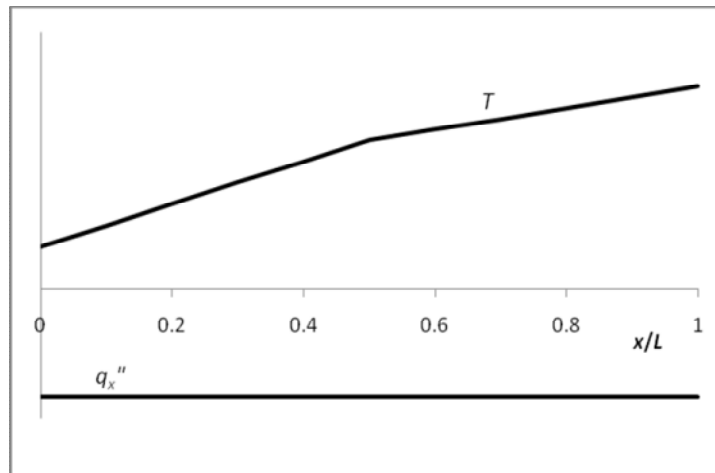

**COMMENTS:** (1) Note the discontinuity in the slope of the temperature distribution at  $x/L = 0.5$ . The constant heat flux is in the negative  $x$ -direction. (2) A discontinuity in the temperature distribution may occur at  $x/L = 0.5$  due the joining of dissimilar materials. We shall address *thermal contact resistances* in Chapter 3.

### PROBLEM 2.7

**KNOWN:** End-face temperatures and temperature dependence of  $k$  for a truncated cone.

**FIND:** Variation with axial distance along the cone of  $q_x$ ,  $q_x''$ ,  $k$ , and  $dT/dx$ .

**SCHEMATIC:**

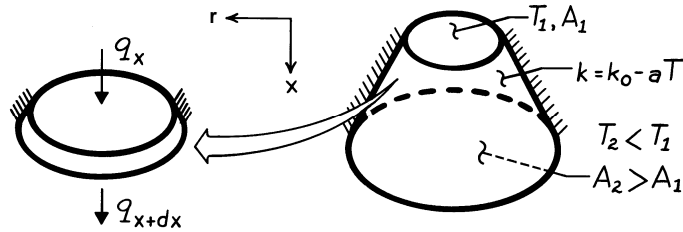

**ASSUMPTIONS:** (1) One-dimensional conduction in  $x$  (negligible temperature gradients in the  $r$  direction), (2) Steady-state conditions, (3) Adiabatic sides, (4) No internal heat generation.

**ANALYSIS:** For the prescribed conditions, it follows from conservation of energy, Eq. 1.12c, that for a differential control volume,  $\dot{E}_{in} = \dot{E}_{out}$  or  $q_x = q_{x+dx}$ . Hence

$q_x$  is independent of  $x$ .

Since  $A(x)$  increases with increasing  $x$ , it follows that  $q_x'' = q_x / A(x)$  decreases with increasing  $x$ . Since  $T$  decreases with increasing  $x$ ,  $k$  increases with increasing  $x$ . Hence, from Fourier's law,

$$q_x'' = -k \frac{dT}{dx},$$

it follows that  $|dT/dx|$  decreases with increasing  $x$ .

**COMMENT:** How is the analysis changed if the coefficient  $a$  has a negative value?

## PROBLEM 2.8

**KNOWN:** Temperature dependence of the thermal conductivity,  $k(T)$ , for heat transfer through a plane wall.

**FIND:** Effect of  $k(T)$  on temperature distribution,  $T(x)$ .

**ASSUMPTIONS:** (1) One-dimensional conduction, (2) Steady-state conditions, (3) No internal heat generation.

**ANALYSIS:** From Fourier's law and the form of  $k(T)$ ,

$$q_x'' = -k \frac{dT}{dx} = -(k_0 + aT) \frac{dT}{dx}. \quad (1)$$

The shape of the temperature distribution may be inferred from knowledge of  $d^2T/dx^2 = d(dT/dx)/dx$ . Since  $q_x''$  is independent of  $x$  for the prescribed conditions,

$$\begin{aligned} \frac{dq_x''}{dx} &= -\frac{d}{dx} \left[ (k_0 + aT) \frac{dT}{dx} \right] = 0 \\ -(k_0 + aT) \frac{d^2T}{dx^2} - a \left[ \frac{dT}{dx} \right]^2 &= 0. \end{aligned}$$

Hence,

$$\frac{d^2T}{dx^2} = \frac{-a}{k_0 + aT} \left[ \frac{dT}{dx} \right]^2 \quad \text{where} \quad \begin{cases} k_0 + aT = k > 0 \\ \left[ \frac{dT}{dx} \right]^2 > 0 \end{cases}$$

from which it follows that for

$$a > 0: \quad d^2T/dx^2 < 0$$

$$a = 0: \quad d^2T/dx^2 = 0$$

$$a < 0: \quad d^2T/dx^2 > 0.$$

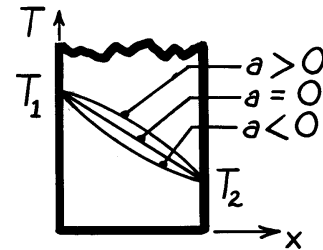

**COMMENTS:** The shape of the distribution could also be inferred from Eq. (1). Since  $T$  decreases with increasing  $x$ ,

$$a > 0: \quad k \text{ decreases with increasing } x \Rightarrow |dT/dx| \text{ increases with increasing } x$$

$$a = 0: \quad k = k_0 \Rightarrow dT/dx \text{ is constant}$$

$$a < 0: \quad k \text{ increases with increasing } x \Rightarrow |dT/dx| \text{ decreases with increasing } x.$$

## PROBLEM 2.9

**KNOWN:** Irradiation and absorptivity of aluminum, glass and aerogel.

**FIND:** Ability of the protective barrier to withstand the irradiation in terms of the temperature gradients that develop in response to the irradiation.

**SCHEMATIC:**

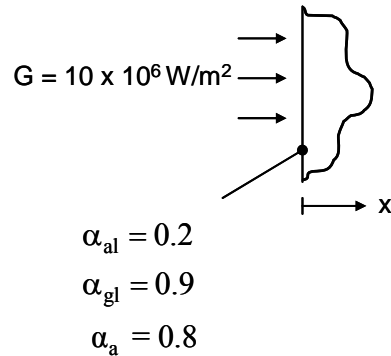

**ASSUMPTIONS:** (1) One-dimensional conduction in the x-direction, (2) Constant properties, (c) Negligible emission and convection from the exposed surface.

**PROPERTIES:** Table A.1, pure aluminum (300 K):  $k_{\text{al}} = 238 \text{ W/m}\cdot\text{K}$ . Table A.3, glass (300 K):  $k_{\text{gl}} = 1.4 \text{ W/m}\cdot\text{K}$ .

**ANALYSIS:** From Eqs. 1.6 and 2.32

$$-k \left. \frac{\partial T}{\partial x} \right|_{x=0} = q_s'' = G_{\text{abs}} = \alpha G$$

or

$$\left. \frac{\partial T}{\partial x} \right|_{x=0} = -\frac{\alpha G}{k}$$

The temperature gradients at  $x = 0$  for the three materials are:

<

Material	$\left. \frac{\partial T}{\partial x} \right _{x=0} \text{ (K/m)}$
aluminum	$8.4 \times 10^3$
glass	$6.4 \times 10^6$
aerogel	$1.6 \times 10^9$

**COMMENT:** It is unlikely that the aerogel barrier can sustain the thermal stresses associated with the large temperature gradient. Low thermal conductivity solids are prone to large temperature gradients, and are often brittle.

### PROBLEM 2.10

**KNOWN:** Wall thickness. Thermal energy generation rate. Temperature distribution. Ambient fluid temperature.

**FIND:** Thermal conductivity. Convection heat transfer coefficient.

**SCHEMATIC:**

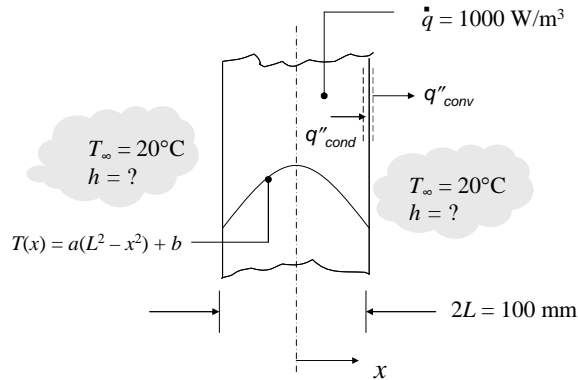

**ASSUMPTIONS:** (1) Steady state, (2) One-dimensional conduction, (3) Constant properties, (4) Negligible radiation.

**ANALYSIS:** Under the specified conditions, the heat equation, Equation 2.21, reduces to

$$\frac{d^2T}{dx^2} + \frac{\dot{q}}{k} = 0$$

With the given temperature distribution,  $d^2T/dx^2 = -2a$ . Therefore, solving for  $k$  gives

$$k = \frac{\dot{q}}{2a} = \frac{1000 \text{ W/m}^3}{2 \times 10^\circ\text{C/m}^2} = 50 \text{ W/m} \cdot \text{K} \quad <$$

The convection heat transfer coefficient can be found by applying the boundary condition at  $x = L$  (or at  $x = -L$ ),

$$-k \left. \frac{dT}{dx} \right|_{x=L} = h[T(L) - T_\infty]$$

Therefore

$$h = \frac{-k \left. \frac{dT}{dx} \right|_{x=L}}{[T(L) - T_\infty]} = \frac{2kaL}{b - T_\infty} = \frac{2 \times 50 \text{ W/m} \cdot \text{K} \times 10^\circ\text{C/m}^2 \times 0.05 \text{ m}}{30^\circ\text{C} - 20^\circ\text{C}} = 5 \text{ W/m}^2 \cdot \text{K} \quad <$$

**COMMENTS:** (1) In Chapter 3, you will learn how to determine the temperature distribution. (2) The heat transfer coefficient could also have been found from an energy balance on the wall. With  $\dot{E}_{\text{in}} - \dot{E}_{\text{out}} + \dot{E}_g = 0$ , we find  $-2hA[T(L) - T_\infty] + 2\dot{q}LA = 0$ . This yields the same result for  $h$ .



## PROBLEM 2.11

**KNOWN:** One-dimensional system with prescribed thermal conductivity and thickness.

**FIND:** Unknowns for various temperature conditions and sketch distribution.

**SCHEMATIC:**

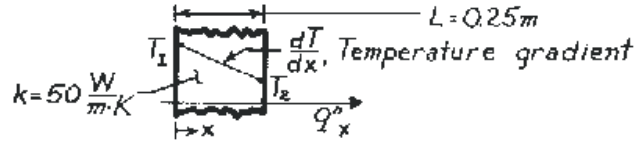

**ASSUMPTIONS:** (1) Steady-state conditions, (2) One-dimensional conduction, (3) No internal heat generation, (4) Constant properties.

**ANALYSIS:** The rate equation and temperature gradient for this system are

$$q_x'' = -k \frac{dT}{dx} \quad \text{and} \quad \frac{dT}{dx} = \frac{T_2 - T_1}{L} \quad (1,2)$$

Using Eqs. (1) and (2), the unknown quantities for each case can be determined.

(a)  $\frac{dT}{dx} = \frac{(-20 - 50) \text{ K}}{0.25 \text{ m}} = -280 \text{ K/m}$

$$q_x'' = -50 \frac{\text{W}}{\text{m} \cdot \text{K}} \times \left[ -280 \frac{\text{K}}{\text{m}} \right] = 14.0 \text{ kW/m}^2.$$

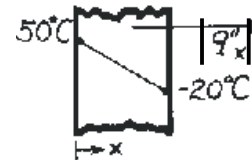

<

(b)  $\frac{dT}{dx} = \frac{(-10 - (-30)) \text{ K}}{0.25 \text{ m}} = 80 \text{ K/m}$

$$q_x'' = -50 \frac{\text{W}}{\text{m} \cdot \text{K}} \times \left[ 80 \frac{\text{K}}{\text{m}} \right] = -4.0 \text{ kW/m}^2.$$



<

(c)  $q_x'' = -50 \frac{\text{W}}{\text{m} \cdot \text{K}} \times \left[ 160 \frac{\text{K}}{\text{m}} \right] = -8.0 \text{ kW/m}^2$

$$T_2 = L \cdot \frac{dT}{dx} + T_1 = 0.25 \text{ m} \times \left[ 160 \frac{\text{K}}{\text{m}} \right] + 70^\circ \text{ C}.$$

$$T_2 = 110^\circ \text{ C}.$$

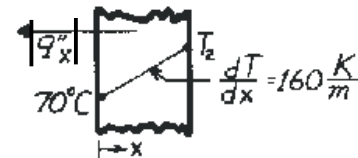

<

(d)  $q_x'' = -50 \frac{\text{W}}{\text{m} \cdot \text{K}} \times \left[ -80 \frac{\text{K}}{\text{m}} \right] = 4.0 \text{ kW/m}^2$

$$T_1 = T_2 - L \cdot \frac{dT}{dx} = 40^\circ \text{ C} - 0.25 \text{ m} \times \left[ -80 \frac{\text{K}}{\text{m}} \right]$$

$$T_1 = 60^\circ \text{ C}.$$

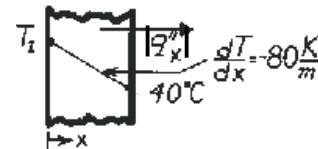

<

(e)  $q_x'' = -50 \frac{\text{W}}{\text{m} \cdot \text{K}} \times \left[ 200 \frac{\text{K}}{\text{m}} \right] = -10.0 \text{ kW/m}^2$

$$T_1 = T_2 - L \cdot \frac{dT}{dx} = 30^\circ \text{ C} - 0.25 \text{ m} \times \left[ 200 \frac{\text{K}}{\text{m}} \right] = -20^\circ \text{ C}.$$

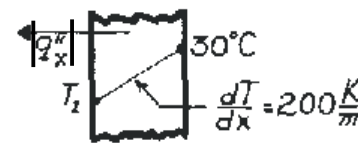

<

## PROBLEM 2.12

**KNOWN:** Plane wall with prescribed thermal conductivity, thickness, and surface temperatures.

**FIND:** Heat flux,  $q''_x$ , and temperature gradient,  $dT/dx$ , for the three different coordinate systems shown.

**SCHEMATIC:**

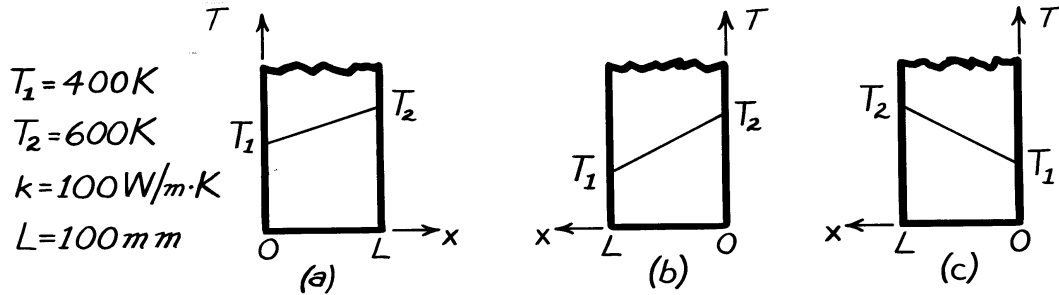

**ASSUMPTIONS:** (1) One-dimensional heat flow, (2) Steady-state conditions, (3) No internal generation, (4) Constant properties.

**ANALYSIS:** The rate equation for conduction heat transfer is

$$q''_x = -k \frac{dT}{dx}, \quad (1)$$

where the temperature gradient is constant throughout the wall and of the form

$$\frac{dT}{dx} = \frac{T(L) - T(0)}{L}. \quad (2)$$

Substituting numerical values, find the temperature gradients,

$$(a) \quad \frac{dT}{dx} = \frac{T_2 - T_1}{L} = \frac{(600 - 400)\text{K}}{0.100\text{m}} = 2000 \text{ K/m} <$$

$$(b) \quad \frac{dT}{dx} = \frac{T_1 - T_2}{L} = \frac{(400 - 600)\text{K}}{0.100\text{m}} = -2000 \text{ K/m} <$$

$$(c) \quad \frac{dT}{dx} = \frac{T_2 - T_1}{L} = \frac{(600 - 400)\text{K}}{0.100\text{m}} = 2000 \text{ K/m} <$$

The heat rates, using Eq. (1) with  $k = 100 \text{ W/m}\cdot\text{K}$ , are

$$(a) \quad q''_x = -100 \frac{\text{W}}{\text{m}\cdot\text{K}} \times 2000 \text{ K/m} = -200 \text{ kW/m}^2 <$$

$$(b) \quad q''_x = -100 \frac{\text{W}}{\text{m}\cdot\text{K}} (-2000 \text{ K/m}) = +200 \text{ kW/m}^2 <$$

$$(c) \quad q''_x = -100 \frac{\text{W}}{\text{m}\cdot\text{K}} \times 2000 \text{ K/m} = -200 \text{ kW/m}^2 <$$

### PROBLEM 2.13

**KNOWN:** Temperature distribution in solid cylinder and convection coefficient at cylinder surface.

**FIND:** Expressions for heat rate at cylinder surface and fluid temperature.

**SCHEMATIC:**

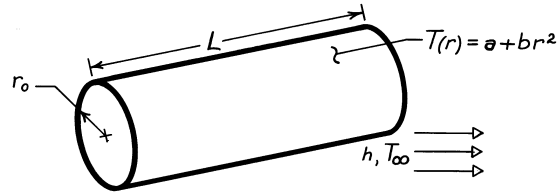

**ASSUMPTIONS:** (1) One-dimensional, radial conduction, (2) Steady-state conditions, (3) Constant properties.

**ANALYSIS:** The heat rate from Fourier's law for the radial (cylindrical) system has the form

$$q_r = -kA_r \frac{dT}{dr}.$$

Substituting for the temperature distribution,  $T(r) = a + br^2$ ,

$$q_r = -k(2\pi rL) 2br = -4\pi kbLr^2.$$

At the outer surface ( $r = r_o$ ), the conduction heat rate is

$$q_{r=r_o} = -4\pi kbLr_o^2. \quad <$$

From a surface energy balance at  $r = r_o$ ,

$$q_{r=r_o} = q_{\text{conv}} = h(2\pi r_o L) [T(r_o) - T_\infty],$$

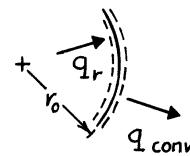

Substituting for  $q_{r=r_o}$  and solving for  $T_\infty$ ,

$$T_\infty = T(r_o) + \frac{2kbr_o}{h}$$

$$T_\infty = a + br_o^2 + \frac{2kbr_o}{h}$$

$$T_\infty = a + br_o \left[ r_o + \frac{2k}{h} \right]. \quad <$$

### PROBLEM 2.14

**KNOWN:** Two-dimensional body with specified thermal conductivity and two isothermal surfaces of prescribed temperatures; one surface, A, has a prescribed temperature gradient.

**FIND:** Temperature gradients,  $\partial T/\partial x$  and  $\partial T/\partial y$ , at the surface B.

**SCHEMATIC:**

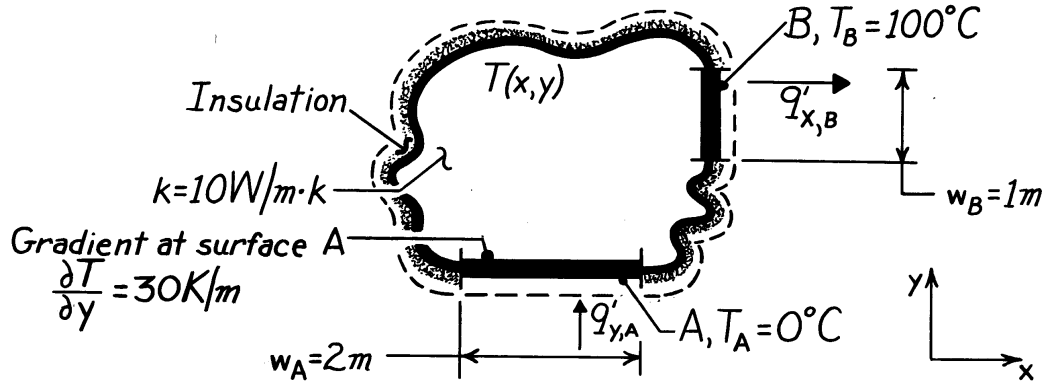

**ASSUMPTIONS:** (1) Two-dimensional conduction, (2) Steady-state conditions, (3) No heat generation, (4) Constant properties.

**ANALYSIS:** At the surface A, the temperature gradient in the x-direction must be zero. That is,  $(\partial T/\partial x)_A = 0$ . This follows from the requirement that the heat flux vector must be normal to an isothermal surface. The heat rate at the surface A is given by Fourier's law written as

$$q'_{y,A} = -k \cdot w_A \left. \frac{\partial T}{\partial y} \right|_A = -10 \frac{\text{W}}{\text{m} \cdot \text{K}} \times 2\text{m} \times 30 \frac{\text{K}}{\text{m}} = -600 \text{W/m}.$$

On the surface B, it follows that

$$(\partial T/\partial y)_B = 0 \quad \leftarrow$$

in order to satisfy the requirement that the heat flux vector be normal to the isothermal surface B. Using the conservation of energy requirement, Eq. 1.12c, on the body, find

$$q'_{y,A} - q'_{x,B} = 0 \quad \text{or} \quad q'_{x,B} = q'_{y,A}.$$

Note that,

$$q'_{x,B} = -k \cdot w_B \left. \frac{\partial T}{\partial x} \right|_B$$

and hence

$$(\partial T/\partial x)_B = \frac{-q'_{y,A}}{k \cdot w_B} = \frac{-(-600 \text{ W/m})}{10 \text{ W/m} \cdot \text{K} \times 1\text{m}} = 60 \text{ K/m}. \quad \leftarrow$$

**COMMENTS:** Note that, in using the conservation requirement,  $q'_{\text{in}} = +q'_{y,A}$  and  $q'_{\text{out}} = +q'_{x,B}$ .

## PROBLEM 2.15

**KNOWN:** Temperature, size and orientation of Surfaces A and B in a two-dimensional geometry. Thermal conductivity dependence on temperature.

**FIND:** Temperature gradient  $\partial T/\partial y$  at surface A.

**SCHEMATIC:**

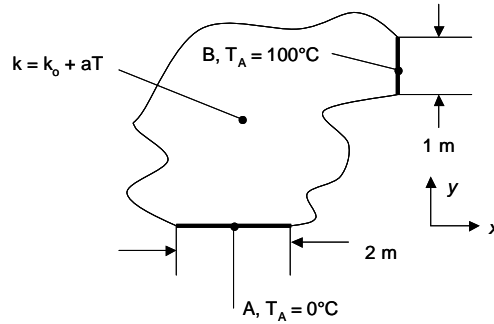

**ASSUMPTIONS:** (1) Steady-state conditions, (2) No volumetric generation, (3) Two-dimensional conduction.

**ANALYSIS:** At Surface A,  $k_A = k_0 + aT_A = 10 \text{ W/m}\cdot\text{K} - 10^{-3} \text{ W/m}\cdot\text{K}^2 \times 273 \text{ K} = 9.73 \text{ W/m}\cdot\text{K}$  while at Surface B,  $k_B = k_0 + aT_B = 10 \text{ W/m}\cdot\text{K} - 10^{-3} \text{ W/m}\cdot\text{K}^2 \times 373 \text{ K} = 9.63 \text{ W/m}\cdot\text{K}$ . For steady-state conditions,  $\dot{E}_{\text{in}} = \dot{E}_{\text{out}}$  which may be written in terms of Fourier's law as

$$-k_B \left. \frac{\partial T}{\partial x} \right|_B A_B = -k_A \left. \frac{\partial T}{\partial y} \right|_A A_A$$

or 
$$\left. \frac{\partial T}{\partial y} \right|_A = \left. \frac{\partial T}{\partial x} \right|_B \frac{k_B A_B}{k_A A_A} = 30 \text{ K/m} \times \frac{9.63}{9.73} \times \frac{1}{2} = 14.85 \text{ K/m} \quad <$$

**COMMENTS:** (1) If the thermal conductivity is not temperature-dependent, then the temperature gradient at A is 15 K/m. (2) Surfaces A and B are both isothermal. Hence,  $\partial T/\partial x|_A = \partial T/\partial y|_B = 0$ .

## PROBLEM 2.16

**KNOWN:** A rod of constant thermal conductivity  $k$  and variable cross-sectional area  $A_x(x) = A_0 e^{ax}$  where  $A_0$  and  $a$  are constants.

**FIND:** (a) Expression for the conduction heat rate,  $q_x(x)$ ; use this expression to determine the temperature distribution,  $T(x)$ ; and sketch of the temperature distribution, (b) Considering the presence of volumetric heat generation rate,  $\dot{q} = \dot{q}_0 \exp(-ax)$ , obtain an expression for  $q_x(x)$  when the left face,  $x = 0$ , is well insulated.

**SCHEMATIC:**

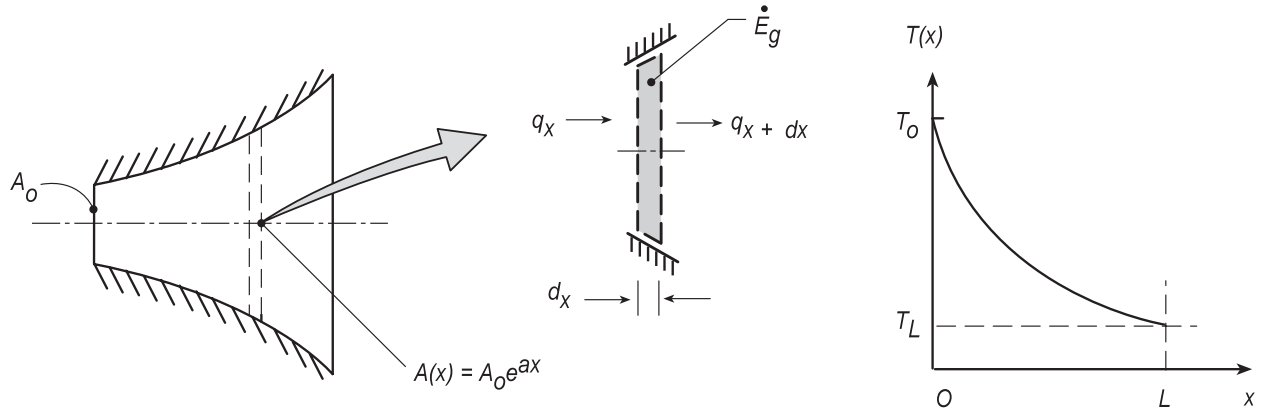

**ASSUMPTIONS:** (1) One-dimensional conduction in the rod, (2) Constant properties, (3) Steady-state conditions.

**ANALYSIS:** Perform an energy balance on the control volume,  $A(x) \cdot dx$ ,

$$\dot{E}_{in} - \dot{E}_{out} + \dot{E}_g = 0$$

$$q_x - q_{x+dx} + \dot{q} \cdot A(x) \cdot dx = 0$$

The conduction heat rate terms can be expressed as a Taylor series and substituting expressions for  $\dot{q}$  and  $A(x)$ ,

$$-\frac{d}{dx}(q_x) + \dot{q}_0 \exp(-ax) \cdot A_0 \exp(ax) = 0 \quad (1)$$

$$q_x = -k \cdot A(x) \frac{dT}{dx} \quad (2)$$

(a) With no internal generation,  $\dot{q}_0 = 0$ , and from Eq. (1) find

$$-\frac{d}{dx}(q_x) = 0 \quad <$$

indicating that the heat rate is constant with  $x$ . By combining Eqs. (1) and (2)

$$-\frac{d}{dx} \left( -k \cdot A(x) \frac{dT}{dx} \right) = 0 \quad \text{or} \quad A(x) \cdot \frac{dT}{dx} = C_1 \quad (3) <$$

Continued...

### PROBLEM 2.16 (Cont.)

That is, the product of the cross-sectional area and the temperature gradient is a constant, independent of  $x$ . Hence, with  $T(0) > T(L)$ , the temperature distribution is exponential, and as shown in the sketch above. Separating variables and integrating Eq. (3), the general form for the temperature distribution can be determined,

$$A_o \exp(ax) \cdot \frac{dT}{dx} = C_1$$

$$dT = C_1 A_o^{-1} \exp(-ax) dx$$

$$T(x) = -C_1 A_o a \exp(-ax) + C_2$$

&lt;

We could use the two temperature boundary conditions,  $T_o = T(0)$  and  $T_L = T(L)$ , to evaluate  $C_1$  and  $C_2$  and, hence, obtain the temperature distribution in terms of  $T_o$  and  $T_L$ .

(b) With the internal generation, from Eq. (1),

$$-\frac{d}{dx}(q_x) + \dot{q}_o A_o = 0 \quad \text{or} \quad q_x = \dot{q}_o A_o x$$

&lt;

That is, the heat rate increases linearly with  $x$ .

**COMMENTS:** In part (b), you could determine the temperature distribution using Fourier's law and knowledge of the heat rate dependence upon the  $x$ -coordinate. Give it a try!

### PROBLEM 2.17

**KNOWN:** Electrical heater sandwiched between two identical cylindrical (30 mm dia. × 60 mm length) samples whose opposite ends contact plates maintained at  $T_o$ .

**FIND:** (a) Thermal conductivity of SS316 samples for the prescribed conditions (A) and their average temperature, (b) Thermal conductivity of Armco iron sample for the prescribed conditions (B), (c) Comment on advantages of experimental arrangement, lateral heat losses, and conditions for which  $\Delta T_1 \neq \Delta T_2$ .

**SCHEMATIC:**

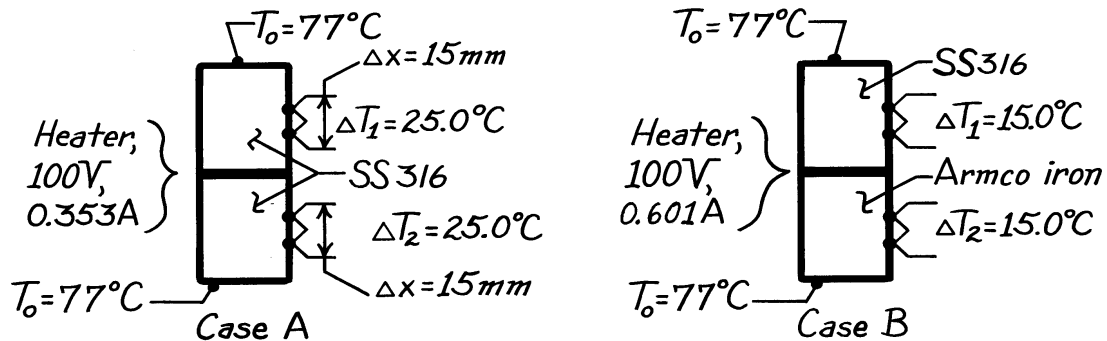

**ASSUMPTIONS:** (1) One-dimensional heat transfer in samples, (2) Steady-state conditions, (3) Negligible contact resistance between materials.

**PROPERTIES:** Table A.2, Stainless steel 316 ( $\bar{T}=400$  K):  $k_{SS} = 15.2$  W/m·K; Armco iron ( $\bar{T}=380$  K):  $k_{iron} = 67.2$  W/m·K.

**ANALYSIS:** (a) For Case A recognize that half the heater power will pass through each of the samples which are presumed identical. Apply Fourier's law to a sample

$$q = kA_c \frac{\Delta T}{\Delta x}$$

$$k = \frac{q\Delta x}{A_c\Delta T} = \frac{0.5(100V \times 0.353A) \times 0.015 \text{ m}}{\pi(0.030 \text{ m})^2 / 4 \times 25.0^\circ\text{C}} = 15.0 \text{ W/m}\cdot\text{K}. \quad <$$

The total temperature drop across the length of the sample is  $\Delta T_1(L/\Delta x) = 25^\circ\text{C} (60 \text{ mm}/15 \text{ mm}) = 100^\circ\text{C}$ . Hence, the heater temperature is  $T_h = 177^\circ\text{C}$ . Thus the average temperature of the sample is

$$\bar{T} = (T_o + T_h) / 2 = 127^\circ\text{C} = 400 \text{ K}. \quad <$$

We compare the calculated value of  $k$  with the tabulated value (see above) at 400 K and note the good agreement.

(b) For Case B, we assume that the thermal conductivity of the SS316 sample is the same as that found in Part (a). The heat rate through the Armco iron sample is

Continued .....



**PROBLEM 2.17 (Cont.)**

$$q_{\text{iron}} = q_{\text{heater}} - q_{\text{ss}} = 100\text{V} \times 0.601\text{A} - 15.0\text{ W/m} \cdot \text{K} \times \frac{\pi (0.030\text{ m})^2}{4} \times \frac{15.0^\circ\text{C}}{0.015\text{ m}}$$
$$q_{\text{iron}} = (60.1 - 10.6)\text{ W} = 49.5\text{ W}$$

where

$$q_{\text{ss}} = k_{\text{ss}} A_c \Delta T_2 / \Delta x_2.$$

Applying Fourier's law to the iron sample,

$$k_{\text{iron}} = \frac{q_{\text{iron}} \Delta x_2}{A_c \Delta T_2} = \frac{49.5\text{ W} \times 0.015\text{ m}}{\pi (0.030\text{ m})^2 / 4 \times 15.0^\circ\text{C}} = 70.0\text{ W/m} \cdot \text{K}. \quad <$$

The total drop across the iron sample is  $15^\circ\text{C}(60/15) = 60^\circ\text{C}$ ; the heater temperature is  $(77 + 60)^\circ\text{C} = 137^\circ\text{C}$ . Hence the average temperature of the iron sample is

$$\bar{T} = (137 + 77)^\circ\text{C} / 2 = 107^\circ\text{C} = 380\text{ K}. \quad <$$

We compare the computed value of  $k$  with the tabulated value (see above) at 380 K and note the good agreement.

(c) The principal advantage of having two identical samples is the assurance that all the electrical power dissipated in the heater will appear as equivalent heat flows through the samples. With only one sample, heat can flow from the backside of the heater even though insulated.

Heat leakage out the lateral surfaces of the cylindrically shaped samples will become significant when the sample thermal conductivity is comparable to that of the insulating material. Hence, the method is suitable for metallics, but must be used with caution on nonmetallic materials.

For any combination of materials in the upper and lower position, we expect  $\Delta T_1 = \Delta T_2$ . However, if the insulation were improperly applied along the lateral surfaces, it is possible that heat leakage will occur, causing  $\Delta T_1 \neq \Delta T_2$ .

## PROBLEM 2.18

**KNOWN:** Geometry and steady-state conditions used to measure the thermal conductivity of an aerogel sheet.

**FIND:** (a) Reason the apparatus of Problem 2.17 cannot be used, (b) Thermal conductivity of the aerogel, (c) Temperature difference across the aluminum sheets, and (d) Outlet temperature of the coolant.

**SCHEMATIC:**

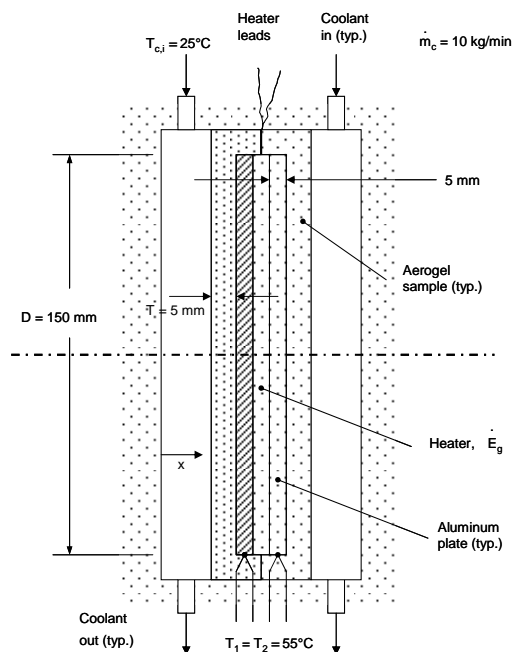

**ASSUMPTIONS:** (1) Steady-state conditions, (2) Constant properties, (3) One-dimensional heat transfer.

**PROPERTIES:** Table A.1, pure aluminum [ $T = (T_1 + T_{c,i})/2 = 40^\circ\text{C} = 313\text{ K}$ ]:  $k_{\text{al}} = 239\text{ W/m}\cdot\text{K}$ . Table A.6, liquid water ( $25^\circ\text{C} = 298\text{ K}$ ):  $c_p = 4180\text{ J/kg}\cdot\text{K}$ .

**ANALYSIS:**

(a) The apparatus of Problem 2.17 cannot be used because it operates under the assumption that the heat transfer is one-dimensional in the axial direction. Since the aerogel is expected to have an extremely small thermal conductivity, the insulation used in Problem 2.17 will likely have a higher thermal conductivity than aerogel. Radial heat losses would be significant, invalidating any measured results.

(b) The electrical power is

$$\dot{E}_g = V(I) = 10\text{ V} \times 0.125\text{ A} = 1.25\text{ W}$$

Continued...

### PROBLEM 2.18 (Cont.)

The conduction heat rate through each aerogel plate is

$$q = \frac{\dot{E}_g}{2} = -k_a A \frac{dT}{dx} = -k_a \left( \frac{\pi D^2}{4} \right) \left( \frac{T_c - T_1}{t} \right)$$

or

$$k_a = \frac{2\dot{E}_g t}{\pi D^2 (T_1 - T_c)} = \frac{2 \times 1.25 \text{ W} \times 0.005 \text{ m}}{\pi \times (0.15 \text{ m})^2 \times (55 - 25)^\circ\text{C}} = 5.9 \times 10^{-3} \frac{\text{W}}{\text{m} \cdot \text{K}} \quad <$$

(c) The conduction heat flux through each aluminum plate is the same as through the aerogel. Hence,

$$-k_a \frac{(T_c - T_1)}{t} = -k_{al} \frac{\Delta T_{al}}{t}$$

or 
$$\Delta T_{al} = \frac{k_a}{k_{al}} (T_1 - T_c) = \frac{5.9 \times 10^{-3} \text{ W/m} \cdot \text{K}}{239 \text{ W/m} \cdot \text{K}} \times 30^\circ\text{C} = 0.74 \times 10^{-3}^\circ\text{C} \quad <$$

The temperature difference across the aluminum plate is negligible. Therefore it is not important to know the location where the thermocouples are attached.

(d) An energy balance on the water yields

$$\dot{E}_g = \dot{m} c_p (T_{c,o} - T_{c,i})$$

or

$$\begin{aligned} T_{c,o} &= T_{c,i} + \frac{\dot{E}_g}{\dot{m} c_p} \\ &= 25^\circ\text{C} + \frac{1.25 \text{ W}}{1 \text{ kg/min} \times \frac{1}{60} \text{ min/s} \times 4180 \text{ J/kg} \cdot \text{K}} = 25.02^\circ\text{C} \quad < \end{aligned}$$

**COMMENTS:** (1) For all practical purposes the aluminum plates may be considered to be isothermal. (2) The coolant may be considered to be isothermal.

## PROBLEM 2.19

**KNOWN:** Dimensions of and temperature difference across an aircraft window. Window materials and cost of energy.

**FIND:** Heat loss through one window and cost of heating for 130 windows on 8-hour trip.

**SCHEMATIC:**

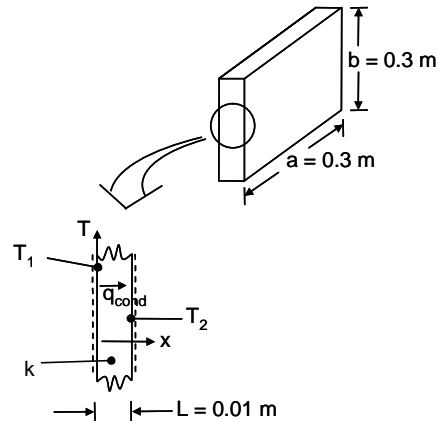

**ASSUMPTIONS:** (1) Steady-state conditions, (2) One-dimensional conduction in the  $x$ -direction, (3) Constant properties.

**PROPERTIES:** Table A.3, soda lime glass (300 K):  $k_{gl} = 1.4 \text{ W/m}\cdot\text{K}$ .

**ANALYSIS:** From Eq. 2.1,

$$q_x = -kA \frac{dT}{dx} = k a b \frac{(T_1 - T_2)}{L}$$

For glass,

$$q_{x,g} = 1.4 \frac{\text{W}}{\text{m}\cdot\text{K}} \times 0.3 \text{ m} \times 0.3 \text{ m} \times \left[ \frac{80^\circ\text{C}}{0.01\text{m}} \right] = 1010 \text{ W} \quad <$$

The cost associated with heat loss through  $N$  windows at a rate of  $R = \$1/\text{kW}\cdot\text{h}$  over a  $t = 8 \text{ h}$  flight time is

$$C_g = Nq_{x,g}Rt = 130 \times 1010 \text{ W} \times 1 \frac{\$}{\text{kW}\cdot\text{h}} \times 8 \text{ h} \times \frac{1\text{kW}}{1000\text{W}} = \$1050 \quad <$$

Repeating the calculation for the polycarbonate yields

$$q_{x,p} = 151 \text{ W}, C_p = \$157 \quad <$$

while for aerogel,

$$q_{x,a} = 10.1 \text{ W}, C_a = \$10 \quad <$$

**COMMENT:** Polycarbonate provides significant savings relative to glass. It is also lighter ( $\rho_p = 1200 \text{ kg/m}^3$ ) relative to glass ( $\rho_g = 2500 \text{ kg/m}^3$ ). The aerogel offers the best thermal performance and is very light ( $\rho_a = 2 \text{ kg/m}^3$ ) but would be relatively expensive.

## PROBLEM 2.20

**KNOWN:** Volume of unknown metal of high thermal conductivity. Known heating rate.

**FIND:** (a) Differential equation that may be used to determine the temperature response of the metal to heating. (b) If the model can be used to identify the metal, based upon matching the predicted and measured thermal responses.

**SCHEMATIC:**

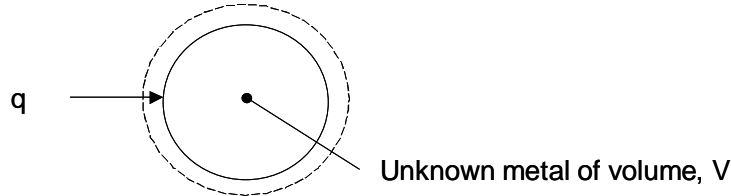

**ASSUMPTIONS:** (1) Negligible spatial temperature gradients, (2) Constant properties.

**PROPERTIES:** Table A.1 ( $T = 300$  K): Aluminum;  $\rho = 2702$  kg/m<sup>3</sup>,  $c_p = 903$  J/kg·K, Gold;  $\rho = 19300$  kg/m<sup>3</sup>,  $c_p = 129$  J/kg·K, Silver;  $\rho = 10500$  kg/m<sup>3</sup>,  $c_p = 235$  J/kg·K.

**ANALYSIS:** (a) An energy balance on the control volume yields  $\dot{E}_{st} = \dot{E}_{in}$  which may be written

$$\rho V c_p \frac{dT}{dt} = q \quad \text{or} \quad \frac{dT}{dt} = \frac{q}{\rho V c_p} = \frac{q}{V} \frac{1}{\rho c_p}$$

The thermal response,  $dT/dt$ , may be measured. Alternatively, the expression may be integrated to find  $T(t)$  given the initial temperature, volume, heat rate, and product of the density and specific heat.

(b) For a known metal volume,  $V$ , the thermal response to constant heating is determined by the product of the density and specific heat,  $\rho c_p$ . This product is listed below for each of the three candidate materials.

Material	$\rho$ (kg/m <sup>3</sup> )	$c_p$ (J/kg·K)	$\rho c_p$ (J/m <sup>3</sup> ·K)
Aluminum	2702	903	$2.44 \times 10^6$
Gold	19300	129	$2.49 \times 10^6$
Silver	10500	235	$2.47 \times 10^6$

Because the product of the densities and specific heats are so similar for these four candidate materials, in general this approach cannot be used to distinguish which material is being heated. <

**COMMENTS:** (1) By neglecting spatial temperature gradients, the proposed approach is based only on thermodynamics principles. Therefore, it is limited in its usefulness relative to alternative schemes discussed in the text such as in Problem 2.23. (2) For many metals, the product of the density and specific heat lies within a relatively narrow band.

## PROBLEM 2.21

**KNOWN:** Temperatures of various materials.

**FIND:** (a) Graph of thermal conductivity,  $k$ , versus temperature,  $T$ , for pure copper, 2024 aluminum and AISI 302 stainless steel for  $300 \leq T \leq 600$  K, (b) Graph of thermal conductivity,  $k$ , for helium and air over the range  $300 \leq T \leq 800$  K, (c) Graph of kinematic viscosity,  $\nu$ , for engine oil, ethylene glycol, and liquid water for  $300 \leq T \leq 360$  K, (d) Graph of thermal conductivity,  $k$ , versus volume fraction,  $\phi$ , of a water- $\text{Al}_2\text{O}_3$  nanofluid for  $0 \leq \phi \leq 0.08$  and  $T = 300$  K. Comment on the trends for each case.

**ASSUMPTION:** (1) Constant nanoparticle properties.

**ANALYSIS:** (a) Using the *IHT* workspace of Comment 1 yields

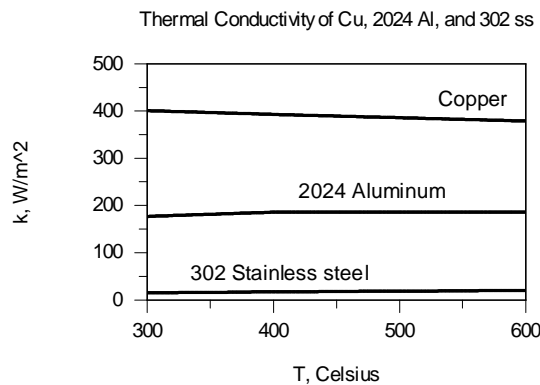

Note the large difference between the thermal conductivities of these metals. Copper conducts thermal energy effectively, while stainless steels are relatively poor thermal conductors. Also note that, depending on the metal, the thermal conductivity increases (2024 Aluminum and 302 Stainless Steel) or decreases (Copper) with temperature.

(b) Using the *IHT* workspace of Comment 2 yields

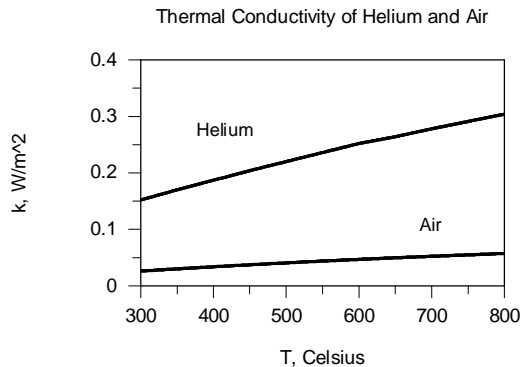

Note the high thermal conductivity of helium relative to that of air. As such, He is sometimes used as a coolant. The thermal conductivity of both gases increases with temperature, as expected from inspection of Figure 2.8.

Continued...

## PROBLEM 2.21 (Cont.)

(c) Using the *IHT* workspace of Comment 3 yields

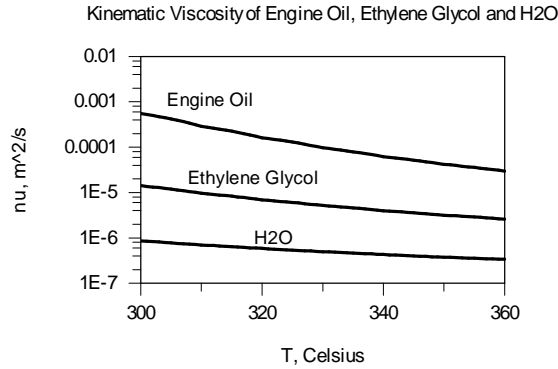

The kinematic viscosities vary by three orders of magnitude between the various liquids. For each case the kinematic viscosity decreases with temperature.

(d) Using the *IHT* workspace of Comment 4 yields

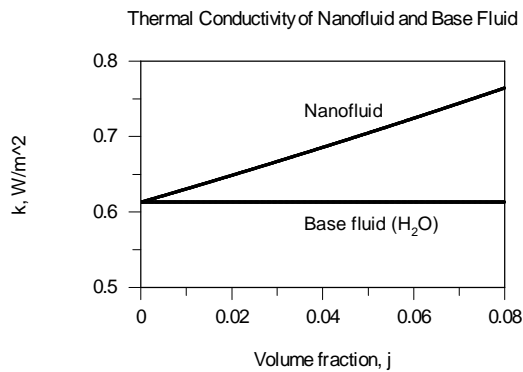

Note the increase in the thermal conductivity of the nanofluid with addition of more nanoparticles. The solid phase usually has a higher thermal conductivity than the liquid phase, as noted in Figures 2.5 and 2.9, respectively.

**COMMENTS:** (1) The *IHT* workspace for part (a) is as follows.

```
// Copper (pure) property functions : From Table A.1
// Units: T(K)
kCu = k_T("Copper",T) // Thermal conductivity,W/m-K

// Aluminum 2024 property functions : From Table A.1
// Units: T(K)
kAl = k_T("Aluminum 2024",T) // Thermal conductivity,W/m-K

// Stainless steel-AISI 302 property functions : From Table A.1
// Units: T(K)
kss = k_T("Stainless Steel-AISI 302",T) // Thermal conductivity,W/m-K

T = 300 // Temperature, K
```

Continued...

## PROBLEM 2.21 (Cont.)

(2) The *IHT* workspace for part (b) follows.

```
// Helium property functions : From Table A.4
// Units: T(K)
kHe = k_T("Helium",T) // Thermal conductivity, W/m·K

// Air property functions : From Table A.4
// Units: T(K); 1 atm pressure
kAir = k_T("Air",T) // Thermal conductivity, W/m·K

T = 300 // Temperature, K
```

(3) The *IHT* workspace for part (c) follows.

```
// Engine Oil property functions : From Table A.5
// Units: T(K)
nuOil = nu_T("Engine Oil",T) // Kinematic viscosity, m^2/s

// Ethylene glycol property functions : From Table A.5
// Units: T(K)
nuEG = nu_T("Ethylene Glycol",T) // Kinematic viscosity, m^2/s

// Water property functions :T dependence, From Table A.6
// Units: T(K), p(bars);
xH2O = 0 // Quality (0=sat liquid or 1=sat vapor)
nuH2O = nu_Tx("Water",T,xH2O) // Kinematic viscosity, m^2/s

T = 300 // Temperature, K
```

(4) The *IHT* workspace for part (d) follows.

```
// Water property functions :T dependence, From Table A.6
// Units: T(K), p(bars);
xH2O = 0 // Quality (0=sat liquid or 1=sat vapor)
kH2O = k_Tx("Water",T,xH2O) // Thermal conductivity, W/m·K
kbf = kH2O
T = 300

j = 0.01 // Volume fraction of nanoparticles

//Particle Properties

kp = 36 // Thermal conductivity, W/mK

knf = (num/den)*kbf
num = kp + 2*kbf-2*j*(kbf - kp)
den = kp + 2*kbf + j*(kbf - kp)
```



## PROBLEM 2.22

**KNOWN:** Ideal gas behavior for air, hydrogen and carbon dioxide.

**FIND:** The thermal conductivity of each gas at 300 K. Compare calculated values to values from Table A.4.

**ASSUMPTIONS:** (1) Ideal gas behavior.

**PROPERTIES:** Table A.4 ( $T = 300$  K): Air;  $c_p = 1007$  J/kg·K,  $k = 0.0263$  W/m·K, Hydrogen;  $c_p = 14,310$  J/kg·K,  $k = 0.183$  W/m·K, Carbon dioxide;  $c_p = 851$  J/kg·K,  $k = 0.0166$  W/m·K. Figure 2.8: Air;  $\mathcal{M} = 28.97$  kg/kmol,  $d = 0.372 \times 10^{-9}$  m, Hydrogen;  $\mathcal{M} = 2.018$  kg/kmol,  $d = 0.274 \times 10^{-9}$  m, Carbon Dioxide;  $\mathcal{M} = 44.01$  kg/kmol,  $d = 0.464 \times 10^{-9}$  m.

**ANALYSIS:** For air, the ideal gas constant, specific heat at constant volume, and ratio of specific heats are:

$$R = \frac{\mathcal{R}}{\mathcal{M}} = \frac{8.315 \text{ kJ/kmol} \cdot \text{K}}{28.97 \text{ kg/kmol}} = 0.287 \frac{\text{kJ}}{\text{kg} \cdot \text{K}};$$

$$c_v = c_p - R = 1.007 \frac{\text{kJ}}{\text{kg} \cdot \text{K}} - 0.287 \frac{\text{kJ}}{\text{kg} \cdot \text{K}} = 0.720 \frac{\text{kJ}}{\text{kg} \cdot \text{K}}; \quad \gamma = \frac{c_p}{c_v} = \frac{1.007}{0.720} = 1.399$$

From Equation 2.12

$$k = \frac{9\gamma - 5}{4} \frac{c_v}{\pi d^2} \sqrt{\frac{\mathcal{M} k_B T}{\mathcal{N} \pi}}$$

$$= \frac{9 \times 1.399 - 5}{4} \times \frac{720 \text{ J/kg} \cdot \text{K}}{\pi (0.372 \times 10^{-9} \text{ m})^2} \sqrt{\frac{28.97 \text{ kg/kmol} \times 1.381 \times 10^{-23} \text{ J/K} \times 300 \text{ K}}{\pi \times 6.024 \times 10^{23} \text{ mol}^{-1} \times 1000 \text{ mol/kmol}}}$$

$$= 0.025 \frac{\text{W}}{\text{m} \cdot \text{K}} \quad <$$

The thermal conductivity of air at  $T = 300$  K is 0.0263 W/m·K. Hence, the computed value is within 5 % of the reported value.

For hydrogen, the ideal gas constant, specific heat at constant volume, and ratio of specific heats are:

$$R = \frac{\mathcal{R}}{\mathcal{M}} = \frac{8.315 \text{ kJ/kmol} \cdot \text{K}}{2.018 \text{ kg/kmol}} = 4.120 \frac{\text{kJ}}{\text{kg} \cdot \text{K}};$$

$$c_v = c_p - R = 14.31 \frac{\text{kJ}}{\text{kg} \cdot \text{K}} - 4.120 \frac{\text{kJ}}{\text{kg} \cdot \text{K}} = 10.19 \frac{\text{kJ}}{\text{kg} \cdot \text{K}}; \quad \gamma = \frac{c_p}{c_v} = \frac{14.31}{10.19} = 1.404$$

Equation 2.12 may be used to calculate

$$k = 0.173 \frac{\text{W}}{\text{m} \cdot \text{K}} \quad <$$

Continued...

### PROBLEM 2.22 (Cont.)

The thermal conductivity of hydrogen at  $T = 300$  K is  $0.183$  W/m·K. Hence, the computed value is within 6 % of the reported value.

For carbon dioxide, the ideal gas constant, specific heat at constant volume, and ratio of specific heats are:

$$R = \frac{\mathcal{R}}{\mathcal{M}} = \frac{8.315 \text{ kJ/kmol} \cdot \text{K}}{44.01 \text{ kg/kmol}} = 0.189 \frac{\text{kJ}}{\text{kg} \cdot \text{K}};$$

$$c_v = c_p - R = 0.851 \frac{\text{kJ}}{\text{kg} \cdot \text{K}} - 0.189 \frac{\text{kJ}}{\text{kg} \cdot \text{K}} = 0.662 \frac{\text{kJ}}{\text{kg} \cdot \text{K}}; \quad \gamma = \frac{c_p}{c_v} = \frac{0.851}{0.662} = 1.285$$

Equation 2.12 may be used to calculate

$$k = 0.0158 \frac{\text{W}}{\text{m} \cdot \text{K}} \quad <$$

The thermal conductivity of carbon dioxide at  $T = 300$  K is  $0.0166$  W/m·K. Hence, the computed value is within 5 % of the reported value.

**COMMENTS:** The preceding analysis may be used to *estimate* the thermal conductivity at various temperatures. However, the analysis is not valid for extreme temperatures or pressures. For example, (1) the thermal conductivity is predicted to be independent of the pressure of the gas. As pure vacuum conditions are approached, the thermal conductivity will suddenly drop to zero, and the preceding analysis is no longer valid. Also, (2) for temperatures considerably higher or lower than normally-encountered room temperatures, the agreement between the predicted and actual thermal conductivities can be poor. For example, for carbon dioxide at  $T = 600$  K, the predicted thermal conductivity is  $k = 0.0223$  W/m·K, while the actual (tabular) value is  $k = 0.0407$  W/m·K. For extreme temperatures, thermal correction factors must be included in the predictions of the thermal conductivity.

### PROBLEM 2.23

**KNOWN:** Identical samples of prescribed diameter, length and density initially at a uniform temperature  $T_i$ , sandwich an electric heater which provides a uniform heat flux  $q_0''$  for a period of time  $\Delta t_0$ . Conditions shortly after energizing and a long time after de-energizing heater are prescribed.

**FIND:** Specific heat and thermal conductivity of the test sample material. From these properties, identify type of material using Table A.1 or A.2.

**SCHEMATIC:**

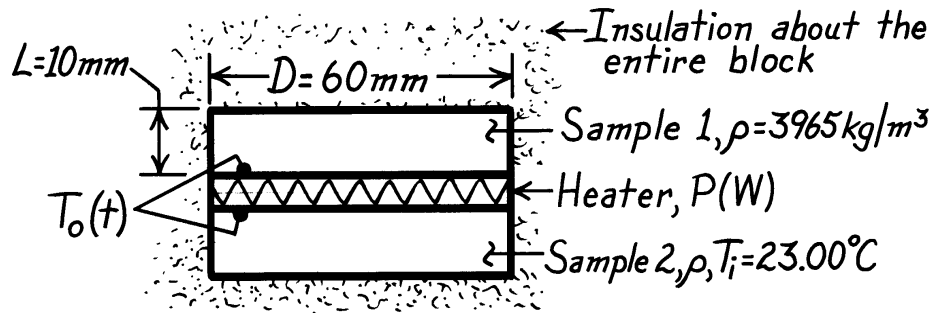

**ASSUMPTIONS:** (1) One dimensional heat transfer in samples, (2) Constant properties, (3) Negligible heat loss through insulation, (4) Negligible heater mass.

**ANALYSIS:** Consider a control volume about the samples and heater, and apply conservation of energy over the time interval from  $t = 0$  to  $\infty$

$$E_{\text{in}} - E_{\text{out}} = \Delta E = E_f - E_i$$

$$P\Delta t_0 - 0 = Mc_p [T(\infty) - T_i]$$

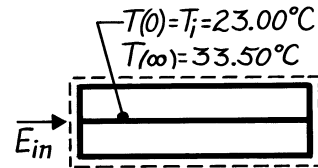

where energy inflow is prescribed by the power condition and the final temperature  $T_f$  is known.

Solving for  $c_p$ ,

$$c_p = \frac{P\Delta t_0}{M [T(\infty) - T_i]} = \frac{15\text{ W} \times 120\text{ s}}{2 \times 3965\text{ kg/m}^3 \left( \pi \times 0.060^2 / 4 \right) \text{ m}^2 \times 0.010\text{ m} [33.50 - 23.00]^\circ\text{C}}$$

$$c_p = 765\text{ J/kg} \cdot \text{K}$$

<

where  $M = \rho V = 2\rho(\pi D^2/4)L$  is the mass of both samples. The transient thermal response of the heater is given by

Continued .....

**PROBLEM 2.23 (Cont.)**

$$T_o(t) - T_i = 2q_o'' \left[ \frac{t}{\pi \rho c_p k} \right]^{1/2}$$

$$k = \frac{t}{\pi \rho c_p} \left[ \frac{2q_o''}{T_o(t) - T_i} \right]^2$$

$$k = \frac{30 \text{ s}}{\pi \times 3965 \text{ kg/m}^3 \times 765 \text{ J/kg} \cdot \text{K}} \left[ \frac{2 \times 2653 \text{ W/m}^2}{(24.57 - 23.00)^\circ \text{C}} \right]^2 = 36.0 \text{ W/m} \cdot \text{K} \quad <$$

where

$$q_o'' = \frac{P}{2A_s} = \frac{P}{2(\pi D^2/4)} = \frac{15 \text{ W}}{2(\pi \times 0.060^2/4) \text{ m}^2} = 2653 \text{ W/m}^2.$$

With the following properties now known,

$$\rho = 3965 \text{ kg/m}^3 \quad c_p = 765 \text{ J/kg} \cdot \text{K} \quad k = 36 \text{ W/m} \cdot \text{K}$$

entries in Table A.1 are scanned to determine whether these values are typical of a metallic material. Consider the following,

- metallics with low  $\rho$  generally have higher thermal conductivities,
- specific heats of both types of materials are of similar magnitude,
- the low  $k$  value of the sample is typical of poor metallic conductors which generally have much higher specific heats,
- more than likely, the material is nonmetallic.

From Table A.2, the second entry, polycrystalline aluminum oxide, has properties at 300 K corresponding to those found for the samples. <

## PROBLEM 2.24

**KNOWN:** Five materials at 300 K.

**FIND:** Heat capacity,  $\rho c_p$ . Which material has highest thermal energy storage per unit volume. Which has lowest cost per unit heat capacity.

**ASSUMPTIONS:** Constant properties.

**PROPERTIES:** Table A.3, Common brick ( $T = 300$  K):  $\rho = 1920$  kg/m<sup>3</sup>,  $c_p = 835$  J/kg·K. Table A.1, Plain carbon steel ( $T = 300$  K):  $\rho = 7854$  kg/m<sup>3</sup>,  $c_p = 434$  J/kg·K. Table A.5, Engine oil ( $T = 300$  K):  $\rho = 884.1$  kg/m<sup>3</sup>,  $c_p = 1909$  J/kg·K. Table A.6, Water ( $T = 300$  K):  $\rho = 1/v_f = 997$  kg/m<sup>3</sup>,  $c_p = 4179$  J/kg·K. Table A.3, Soil ( $T = 300$  K):  $\rho = 2050$  kg/m<sup>3</sup>,  $c_p = 1840$  J/kg·K.

**ANALYSIS:** The values of heat capacity,  $\rho c_p$ , are tabulated below.

Material	Common brick	Plain carbon steel	Engine oil	Water	Soil
Heat Capacity (kJ/m <sup>3</sup> ·K)	1603	3409	1688	4166	3772

Thermal energy storage refers to either sensible or latent energy. The change in sensible energy per unit volume due to a temperature change  $\Delta T$  is equal to  $\rho c_p \Delta T$ . Thus, for a given temperature change, the heat capacity values in the table above indicate the relative amount of sensible energy that can be stored in the material.

Of the materials considered, water has the largest capacity for sensible energy storage.

Various materials also have the potential for latent energy storage due to either a solid-liquid or liquid-vapor phase change. Taking water as an example, the latent heat of fusion is 333.7 kJ/kg. With a density of  $\rho \approx 1000$  kg/m<sup>3</sup> at 0°C, the latent energy per unit volume associated with the solid-liquid phase transition is 333,700 kJ/m<sup>3</sup>. This corresponds to an 80°C temperature change in the liquid phase. The latent heat of vaporization for water is very large, 2257 kJ/kg, but it is generally inconvenient to use a liquid-vapor phase change for thermal energy storage because of the large volume change.

The two materials with the largest heat capacity are also inexpensive. The consumer price of soil is around \$15 per cubic meter, or around \$4 per MJ/K. The consumer price of water is around \$0.40 per cubic meter, or around \$0.10 per MJ/K. In a commercial application, soil could probably be obtained much more inexpensively.

Therefore we conclude that water has the lowest cost per unit heat capacity of the materials considered.

**COMMENTS:** (1) Many materials used for latent thermal energy storage are characterized by relatively low thermal conductivities. Therefore, although the materials may be attractive from the thermodynamics point of view, it can be difficult to deliver energy to the solid-liquid or liquid-vapor interface because of the poor thermal conductivity of the material. Hence, many latent thermal energy storage applications are severely hampered by heat transfer limitations. (2) Most liquids and solids have a heat capacity which is in a fairly narrow range of around 1000 – 4000 kJ/m<sup>3</sup>·K. Gases have heat capacities that are orders of magnitude smaller.

### PROBLEM 2.25

**KNOWN:** Diameter, length, and mass of stainless steel rod, insulated on its exterior surface other than ends. Temperature distribution.

**FIND:** Heat flux.

**SCHEMATIC:**

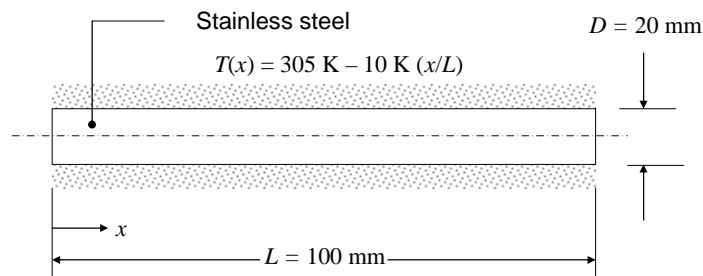

**ASSUMPTIONS:** (1) Steady-state conditions, (2) One-dimensional conduction in  $x$ -direction, (3) Constant properties.

**ANALYSIS:** The heat flux can be found from Fourier's law,

$$q_x'' = -k \frac{dT}{dx}$$

Table A.1 gives values for the thermal conductivity of stainless steels, however we are not told which type of stainless steel the rod is made of, and the thermal conductivity varies between them. We do know the mass of the rod, and can use this to calculate its density:

$$\rho = \frac{M}{V} = \frac{M}{\pi D^2 L / 4} = \frac{0.248 \text{ kg}}{\pi \times (0.02 \text{ m})^2 \times 0.1 \text{ m} / 4} = 7894 \text{ kg/m}^3$$

From Table A.1, it appears that the material is AISI 304 stainless steel. The temperature of the rod varies from 295 K to 305 K. Evaluating the thermal conductivity at 300 K,  $k = 14.9 \text{ W/m}\cdot\text{K}$ . Thus,

$$q_x'' = -k \frac{dT}{dx} = -k(-b/L) = 14.9 \text{ W/m}\cdot\text{K} \times 10 \text{ K} / 0.1 \text{ m} = 1490 \text{ W/m}^2 \quad <$$

**COMMENTS:** If the temperature of the rod varies significantly along its length, the thermal conductivity will vary along the rod as much or more than the variation in thermal conductivities between the different stainless steels.

### PROBLEM 2.26

**KNOWN:** Temperature distribution,  $T(x,y,z)$ , within an infinite, homogeneous body at a given instant of time.

**FIND:** Regions where the temperature changes with time.

**SCHEMATIC:**

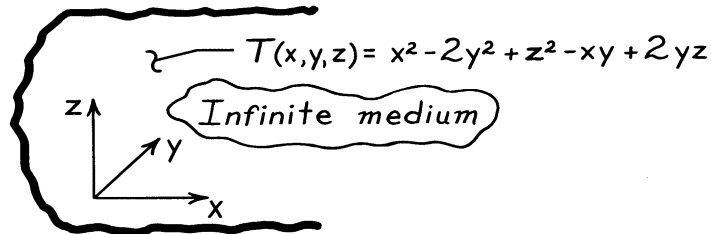

**ASSUMPTIONS:** (1) Constant properties of infinite medium and (2) No internal heat generation.

**ANALYSIS:** The temperature distribution throughout the medium, at any instant of time, must satisfy the heat equation. For the three-dimensional cartesian coordinate system, with constant properties and no internal heat generation, the heat equation, Eq. 2.21, has the form

$$\frac{\partial^2 T}{\partial x^2} + \frac{\partial^2 T}{\partial y^2} + \frac{\partial^2 T}{\partial z^2} = \frac{1}{\alpha} \frac{\partial T}{\partial t} \quad (1)$$

If  $T(x,y,z)$  satisfies this relation, conservation of energy is satisfied at every point in the medium. Substituting  $T(x,y,z)$  into the Eq. (1), first find the gradients,  $\partial T/\partial x$ ,  $\partial T/\partial y$ , and  $\partial T/\partial z$ .

$$\frac{\partial}{\partial x}(2x-y) + \frac{\partial}{\partial y}(-4y-x+2z) + \frac{\partial}{\partial z}(2z+2y) = \frac{1}{\alpha} \frac{\partial T}{\partial t}$$

Performing the differentiations,

$$2 - 4 + 2 = \frac{1}{\alpha} \frac{\partial T}{\partial t}$$

Hence,

$$\frac{\partial T}{\partial t} = 0$$

which implies that, at the prescribed instant, the temperature is everywhere independent of time. <

**COMMENTS:** Since we do not know the initial and boundary conditions, we cannot determine the temperature distribution,  $T(x,y,z)$ , at any future time. We can only determine that, for this special instant of time, the temperature will not change.

## PROBLEM 2.27

**KNOWN:** Diameter  $D$ , thickness  $L$  and initial temperature  $T_i$  of pan. Heat rate from stove to bottom of pan. Convection coefficient  $h$  and variation of water temperature  $T_\infty(t)$  during Stage 1. Temperature  $T_L$  of pan surface in contact with water during Stage 2.

**FIND:** Form of heat equation and boundary conditions associated with the two stages.

**SCHEMATIC:**

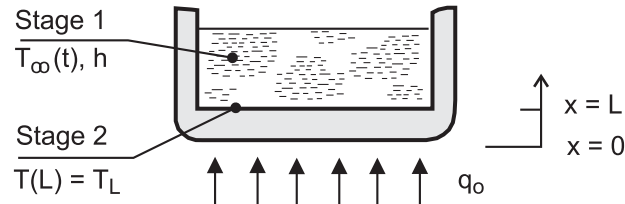

**ASSUMPTIONS:** (1) One-dimensional conduction in pan bottom, (2) Heat transfer from stove is uniformly distributed over surface of pan in contact with the stove, (3) Constant properties.

**ANALYSIS:**

*Stage 1*

$$\text{Heat Equation: } \frac{\partial^2 T}{\partial x^2} = \frac{1}{\alpha} \frac{\partial T}{\partial t}$$

$$\text{Boundary Conditions: } -k \left. \frac{\partial T}{\partial x} \right|_{x=0} = q_o'' = \frac{q_o}{(\pi D^2 / 4)}$$

$$-k \left. \frac{\partial T}{\partial x} \right|_{x=L} = h [T(L, t) - T_\infty(t)]$$

$$\text{Initial Condition: } T(x, 0) = T_i$$

*Stage 2*

$$\text{Heat Equation: } \frac{d^2 T}{dx^2} = 0$$

$$\text{Boundary Conditions: } -k \left. \frac{dT}{dx} \right|_{x=0} = q_o''$$

$$T(L) = T_L$$

**COMMENTS:** Stage 1 is a transient process for which  $T_\infty(t)$  must be determined separately. As a first approximation, it could be estimated by neglecting changes in thermal energy storage by the pan bottom and assuming that all of the heat transferred from the stove acted to increase thermal energy storage within the water. Hence, with  $q \approx Mc_p dT_\infty/dt$ , where  $M$  and  $c_p$  are the mass and specific heat of the water in the pan,  $T_\infty(t) \approx (q/Mc_p) t$ .



## PROBLEM 2.28

**KNOWN:** Steady-state temperature distribution in a cylindrical rod having uniform heat generation of  $\dot{q}_1 = 5 \times 10^7 \text{ W/m}^3$ .

**FIND:** (a) Steady-state centerline and surface heat transfer rates per unit length,  $q'_r$ . (b) Initial time rate of change of the centerline and surface temperatures in response to a change in the generation rate from  $\dot{q}_1$  to  $\dot{q}_2 = 10^8 \text{ W/m}^3$ .

**SCHEMATIC:**

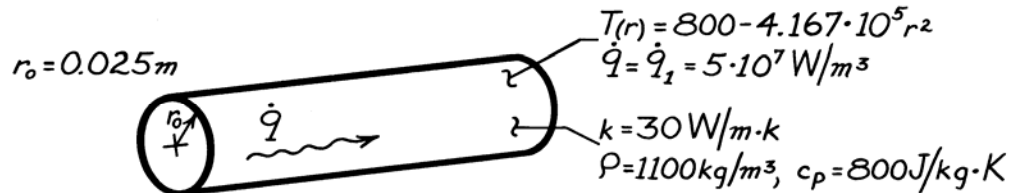

**ASSUMPTIONS:** (1) One-dimensional conduction in the  $r$  direction, (2) Uniform generation, and (3) Steady-state for  $\dot{q}_1 = 5 \times 10^7 \text{ W/m}^3$ .

**ANALYSIS:** (a) From the rate equations for cylindrical coordinates,

$$q'_r = -k \frac{\partial T}{\partial r} \quad q = -kA_r \frac{\partial T}{\partial r}.$$

Hence,

$$q_r = -k(2\pi rL) \frac{\partial T}{\partial r}$$

or

$$q'_r = -2\pi k r \frac{\partial T}{\partial r} \tag{1}$$

where  $\partial T/\partial r$  may be evaluated from the prescribed temperature distribution,  $T(r)$ .

At  $r = 0$ , the gradient is  $(\partial T/\partial r) = 0$ . Hence, from Equation (1) the heat rate is

$$q'_r(0) = 0. \tag{2}$$

At  $r = r_o$ , the temperature gradient is

$$\left. \frac{\partial T}{\partial r} \right|_{r=r_o} = -2 \left[ 4.167 \times 10^5 \frac{\text{K}}{\text{m}^2} \right] (r_o) = -2 (4.167 \times 10^5) (0.025 \text{ m})$$

$$\left. \frac{\partial T}{\partial r} \right|_{r=r_o} = -0.208 \times 10^5 \text{ K/m}.$$

Continued .....

### PROBLEM 2.28 (Cont.)

Hence, the heat rate at the outer surface ( $r = r_o$ ) per unit length is

$$q'_r(r_o) = -2\pi[30 \text{ W/m}\cdot\text{K}](0.025\text{m})\left[-0.208\times 10^5 \text{ K/m}\right]$$

$$q'_r(r_o) = 0.980\times 10^5 \text{ W/m.} \quad <$$

(b) Transient (time-dependent) conditions will exist when the generation is changed, and for the prescribed assumptions, the temperature is determined by the following form of the heat equation, Equation 2.26

$$\frac{1}{r} \frac{\partial}{\partial r} \left[ kr \frac{\partial T}{\partial r} \right] + \dot{q}_2 = \rho c_p \frac{\partial T}{\partial t}$$

Hence

$$\frac{\partial T}{\partial t} = \frac{1}{\rho c_p} \left[ \frac{1}{r} \frac{\partial}{\partial r} \left[ kr \frac{\partial T}{\partial r} \right] + \dot{q}_2 \right].$$

However, initially (at  $t = 0$ ), the temperature distribution is given by the prescribed form,  $T(r) = 800 - 4.167\times 10^{-5} r^2$ , and

$$\begin{aligned} \frac{1}{r} \frac{\partial}{\partial r} \left[ kr \frac{\partial T}{\partial r} \right] &= \frac{k}{r} \frac{\partial}{\partial r} \left[ r \left( -8.334\times 10^5 \cdot r \right) \right] \\ &= \frac{k}{r} \left( -16.668\times 10^5 \cdot r \right) \\ &= 30 \text{ W/m}\cdot\text{K} \left[ -16.668\times 10^5 \text{ K/m}^2 \right] \\ &= -5\times 10^7 \text{ W/m}^3 \text{ (the original } \dot{q}=\dot{q}_1 \text{)}. \end{aligned}$$

Hence, everywhere in the wall,

$$\frac{\partial T}{\partial t} = \frac{1}{1100 \text{ kg/m}^3 \times 800 \text{ J/kg}\cdot\text{K}} \left[ -5\times 10^7 + 10^8 \right] \text{ W/m}^3$$

or

$$\frac{\partial T}{\partial t} = 56.82 \text{ K/s.} \quad <$$

**COMMENTS:** (1) The value of  $(\partial T/\partial t)$  will decrease with increasing time, until a new steady-state condition is reached and once again  $(\partial T/\partial t) = 0$ . (2) By applying the energy conservation requirement, Equation 1.12c, to a unit length of the rod for the steady-state condition,  $\dot{E}'_{in} - \dot{E}'_{out} + \dot{E}'_{gen} = 0$ .

$$\text{Hence } q'_r(0) - q'_r(r_o) = -\dot{q}_1 (\pi r_o^2).$$

## PROBLEM 2.29

**KNOWN:** Plane wall with constant properties and uniform volumetric energy generation. Insulated left face and isothermal right face.

**FIND:** (a) Expression for the heat flux distribution based upon the heat equation. (b) Expression for the heat flux distribution based upon a finite control volume.

**SCHEMATIC:**

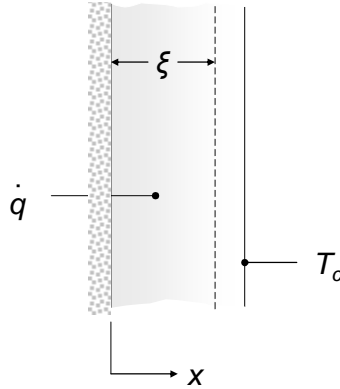

**ASSUMPTIONS:** (1) Steady-state conditions, (2) Constant properties, (3) Uniform volumetric generation, (4) One-dimensional conduction.

**ANALYSIS:** (a) The appropriate form of the heat equation is Eq. 2.19 which may be written as

$$\frac{d^2T}{dx^2} = \frac{d}{dx} \left( \frac{dT}{dx} \right) = -\frac{\dot{q}}{k}$$

The heat equation may be integrated once to yield

$$\frac{dT}{dx} = -\frac{\dot{q}}{k}x + C_1 \quad \text{and, since } \left. \frac{dT}{dx} \right|_{x=0} = 0, C_1 = 0. \text{ Therefore, } -k \frac{dT}{dx} = q''(x) = -\dot{q}x \quad <$$

(b) For the finite control volume,  $\dot{E}_g = \dot{E}_{\text{out}}$ , and for a unit cross-sectional area,

$$\dot{q}(\xi) = -k \left. \frac{dT}{dx} \right|_{x=\xi} \quad \text{which may be re-arranged to yield } -k \frac{dT}{dx} = q''(x) = -\dot{q}\xi = -\dot{q}x \quad <$$

The expressions for the local heat flux are identical.

**COMMENTS:** (1) Although the two methods yield identical results, as they must, the heat equation is more general and can be used to determine temperature and heat flux distributions in more complex situations. (2) The value of the right face temperature is not needed to solve the problem. Is the value of  $T_c$  needed to determine the temperature distribution?

### PROBLEM 2.30

**KNOWN:** Temperature distribution in a one-dimensional wall with prescribed thickness and thermal conductivity.

**FIND:** (a) The heat generation rate,  $\dot{q}$ , in the wall, (b) Heat fluxes at the wall faces and relation to  $\dot{q}$ .

**SCHEMATIC:**

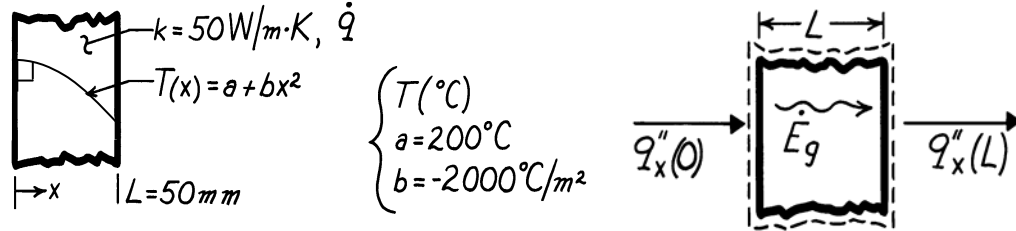

**ASSUMPTIONS:** (1) Steady-state conditions, (2) One-dimensional heat flow, (3) Constant properties.

**ANALYSIS:** (a) The appropriate form of the heat equation for steady-state, one-dimensional conditions with constant properties is Eq. 2.21 re-written as

$$\dot{q} = -k \frac{d}{dx} \left[ \frac{dT}{dx} \right]$$

Substituting the prescribed temperature distribution,

$$\dot{q} = -k \frac{d}{dx} \left[ \frac{d}{dx} (a + bx^2) \right] = -k \frac{d}{dx} [2bx] = -2bk$$

$$\dot{q} = -2(-2000^{\circ}\text{C/m}^2) \times 50 \text{ W/m}\cdot\text{K} = 2.0 \times 10^5 \text{ W/m}^3. \quad <$$

(b) The heat fluxes at the wall faces can be evaluated from Fourier's law,

$$q''_x(x) = -k \left. \frac{dT}{dx} \right|_x.$$

Using the temperature distribution  $T(x)$  to evaluate the gradient, find

$$q''_x(x) = -k \frac{d}{dx} [a + bx^2] = -2kbx.$$

The fluxes at  $x = 0$  and  $x = L$  are then

$$q''_x(0) = 0 \quad <$$

$$q''_x(L) = -2kbL = -2 \times 50 \text{ W/m}\cdot\text{K} (-2000^{\circ}\text{C/m}^2) \times 0.050 \text{ m}$$

$$q''_x(L) = 10,000 \text{ W/m}^2. \quad <$$

**COMMENTS:** From an overall energy balance on the wall, it follows that, for a unit area,

$$\dot{E}_{\text{in}} - \dot{E}_{\text{out}} + \dot{E}_g = 0 \quad q''_x(0) - q''_x(L) + \dot{q}L = 0$$

$$\dot{q} = \frac{q''_x(L) - q''_x(0)}{L} = \frac{10,000 \text{ W/m}^2 - 0}{0.050 \text{ m}} = 2.0 \times 10^5 \text{ W/m}^3.$$

### PROBLEM 2.31

**KNOWN:** Wall thickness, thermal conductivity, temperature distribution, and fluid temperature.

**FIND:** (a) Surface heat rates and rate of change of wall energy storage per unit area, and (b) Convection coefficient.

**SCHEMATIC:**

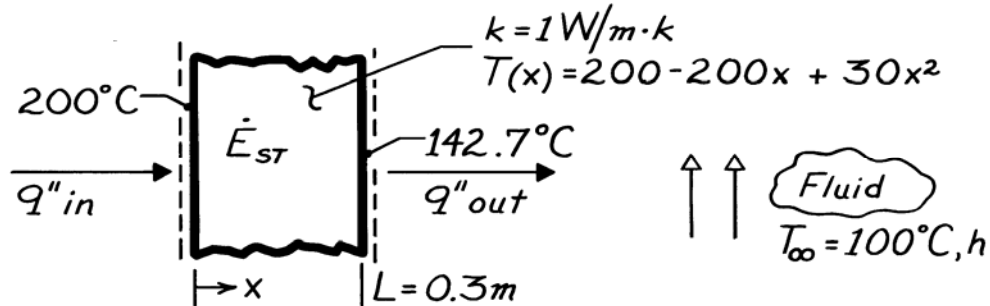

**ASSUMPTIONS:** (1) One-dimensional conduction in  $x$ , (2) Constant  $k$ .

**ANALYSIS:** (a) From Fourier's law,

$$q''_x = -k \frac{\partial T}{\partial x} = (200 - 60x) \cdot k$$

$$q''_{in} = q''_{x=0} = 200 \frac{^\circ\text{C}}{\text{m}} \times 1 \frac{\text{W}}{\text{m} \cdot \text{K}} = 200 \text{ W/m}^2 \quad <$$

$$q''_{out} = q''_{x=L} = (200 - 60 \times 0.3) \text{ }^\circ\text{C/m} \times 1 \text{ W/m} \cdot \text{K} = 182 \text{ W/m}^2. \quad <$$

Applying an energy balance to a control volume about the wall, Eq. 1.12c,

$$\dot{E}''_{in} - \dot{E}''_{out} = \dot{E}''_{st}$$

$$\dot{E}''_{st} = q''_{in} - q''_{out} = 18 \text{ W/m}^2. \quad <$$

(b) Applying a surface energy balance at  $x = L$ ,

$$q''_{out} = h [T(L) - T_\infty]$$

$$h = \frac{q''_{out}}{T(L) - T_\infty} = \frac{182 \text{ W/m}^2}{(142.7 - 100)^\circ\text{C}}$$

$$h = 4.3 \text{ W/m}^2 \cdot \text{K}. \quad <$$

**COMMENTS:** (1) From the heat equation,

$$(\partial T / \partial t) = (k / \rho c_p) \partial^2 T / \partial x^2 = 60(k / \rho c_p),$$

it follows that the temperature is increasing with time at every point in the wall.

(2) The value of  $h$  is small and is typical of free convection in a gas.

### PROBLEM 2.32

**KNOWN:** Analytical expression for the steady-state temperature distribution of a plane wall experiencing uniform volumetric heat generation  $\dot{q}$  while convection occurs at both of its surfaces.

**FIND:** (a) Sketch the temperature distribution,  $T(x)$ , and identify significant physical features, (b) Determine  $\dot{q}$ , (c) Determine the surface heat fluxes,  $q_x''(-L)$  and  $q_x''(+L)$ ; how are these fluxes related to the generation rate; (d) Calculate the convection coefficients at the surfaces  $x = L$  and  $x = +L$ , (e) Obtain an expression for the heat flux distribution,  $q_x''(x)$ ; explain significant features of the distribution; (f) If the source of heat generation is suddenly deactivated ( $\dot{q} = 0$ ), what is the rate of change of energy stored at this instant; (g) Determine the temperature that the wall will reach eventually with  $\dot{q} = 0$ ; determine the energy that must be removed by the fluid per unit area of the wall to reach this state.

**SCHEMATIC:**

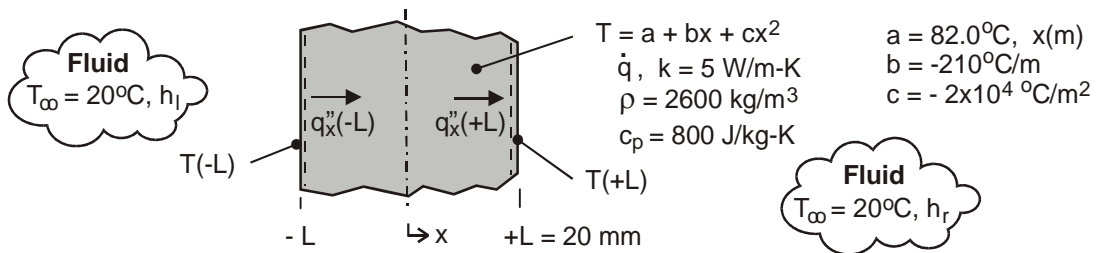

**ASSUMPTIONS:** (1) Steady-state conditions, (2) Uniform volumetric heat generation, (3) Constant properties.

**ANALYSIS:** (a) Using the analytical expression in the Workspace of IHT, the temperature distribution appears as shown below. The significant features include (1) parabolic shape, (2) maximum does not occur at the mid-plane,  $T(-5.25 \text{ mm}) = 83.3^\circ\text{C}$ , (3) the gradient at the  $x = +L$  surface is greater than at  $x = -L$ . Find also that  $T(-L) = 78.2^\circ\text{C}$  and  $T(+L) = 69.8^\circ\text{C}$  for use in part (d).

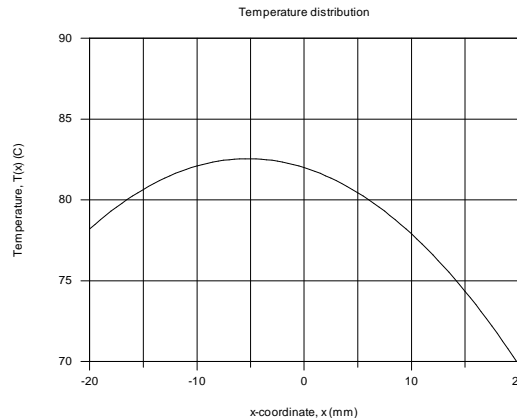

(b) Substituting the temperature distribution expression into the appropriate form of the heat diffusion equation, Eq. 2.21, the rate of volumetric heat generation can be determined.

$$\frac{d}{dx} \left( \frac{dT}{dx} \right) + \frac{\dot{q}}{k} = 0 \quad \text{where} \quad T(x) = a + bx + cx^2$$

$$\frac{d}{dx} (0 + b + 2cx) + \frac{\dot{q}}{k} = (0 + 2c) + \frac{\dot{q}}{k} = 0$$

Continued .....

**PROBLEM 2.32 (Cont.)**

$$\dot{q} = -2ck = -2\left(-2 \times 10^4 \text{C/m}^2\right) 5 \text{ W/m} \cdot \text{K} = 2 \times 10^5 \text{ W/m}^3 \quad <$$

(c) The heat fluxes at the two boundaries can be determined using Fourier's law and the temperature distribution expression.

$$q_x''(x) = -k \frac{dT}{dx} \quad \text{where} \quad T(x) = a + bx + cx^2$$

$$q_x''(-L) = -k[0 + b + 2cx]_{x=-L} = -[b - 2cL]k$$

$$q_x''(-L) = -\left[-210 \text{C/m} - 2\left(-2 \times 10^4 \text{C/m}^2\right) 0.020 \text{m}\right] \times 5 \text{ W/m} \cdot \text{K} = -2950 \text{ W/m}^2 \quad <$$

$$q_x''(+L) = -(b + 2cL)k = +5050 \text{ W/m}^2 \quad <$$

From an overall energy balance on the wall as shown in the sketch below,  $\dot{E}_{in} - \dot{E}_{out} + \dot{E}_{gen} = 0$ ,

$$+q_x''(-L) - q_x''(+L) + 2\dot{q}L = 0 \quad \text{or} \quad -2950 \text{ W/m}^2 - 5050 \text{ W/m}^2 + 8000 \text{ W/m}^2 = 0$$

where  $2\dot{q}L = 2 \times 2 \times 10^5 \text{ W/m}^3 \times 0.020 \text{ m} = 8000 \text{ W/m}^2$ , so the equality is satisfied

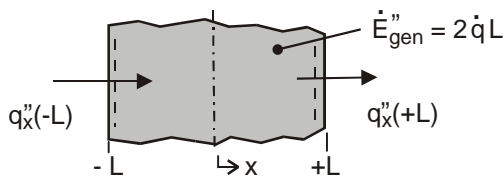

Part (c) Overall energy balance

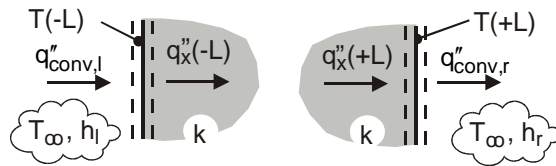

Part (d) Surface energy balances

(d) The convection coefficients,  $h_l$  and  $h_r$ , for the left- and right-hand boundaries ( $x = -L$  and  $x = +L$ , respectively), can be determined from the convection heat fluxes that are equal to the conduction fluxes at the boundaries. See the surface energy balances in the sketch above. See also part (a) result for  $T(-L)$  and  $T(+L)$ .

$$q_{\text{conv},l}'' = q_x''(-L)$$

$$h_l [T_\infty - T(-L)] = h_l [20 - 78.2] \text{K} = -2950 \text{ W/m}^2 \quad h_l = 51 \text{ W/m}^2 \cdot \text{K} \quad <$$

$$q_{\text{conv},r}'' = q_x''(+L)$$

$$h_r [T(+L) - T_\infty] = h_r [69.8 - 20] \text{K} = +5050 \text{ W/m}^2 \quad h_r = 101 \text{ W/m}^2 \cdot \text{K} \quad <$$

(e) The expression for the heat flux distribution can be obtained from Fourier's law with the temperature distribution

$$q_x''(x) = -k \frac{dT}{dx} = -k[0 + b + 2cx]$$

$$q_x''(x) = -5 \text{ W/m} \cdot \text{K} \left[ -210 \text{C/m} + 2\left(-2 \times 10^4 \text{C/m}^2\right) x \right] = 1050 + 2 \times 10^5 x \quad <$$

Continued .....

**PROBLEM 2.32 (Cont.)**

The distribution is linear with the x-coordinate. The maximum temperature will occur at the location where  $q_x''(x_{\max}) = 0$ ,

$$x_{\max} = -\frac{1050 \text{ W/m}^2}{2 \times 10^5 \text{ W/m}^3} = -5.25 \times 10^{-3} \text{ m} = -5.25 \text{ mm} \quad <$$

(f) If the source of the heat generation is suddenly deactivated so that  $\dot{q} = 0$ , the appropriate form of the heat diffusion equation for the ensuing transient conduction is

$$k \frac{\partial}{\partial x} \left( \frac{\partial T}{\partial x} \right) = \rho c_p \frac{\partial T}{\partial t}$$

At the instant this occurs, the temperature distribution is still  $T(x) = a + bx + cx^2$ . The right-hand term represents the rate of energy storage per unit volume,

$$\dot{E}_{\text{st}}'' = k \frac{\partial}{\partial x} [0 + b + 2cx] = k [0 + 2c] = 5 \text{ W/m} \cdot \text{K} \times 2 \left( -2 \times 10^4 \text{ }^\circ\text{C/m}^2 \right) = -2 \times 10^5 \text{ W/m}^3 \quad <$$

(g) With no heat generation, the wall will eventually ( $t \rightarrow \infty$ ) come to equilibrium with the fluid,

$T(x, \infty) = T_\infty = 20^\circ\text{C}$ . To determine the energy that must be removed from the wall to reach this state, apply the conservation of energy requirement over an interval basis, Eq. 1.12b. The “initial” state is that corresponding to the steady-state temperature distribution,  $T_i$ , and the “final” state has  $T_f = 20^\circ\text{C}$ .

We've used  $T_\infty$  as the reference condition for the energy terms.

$$E_{\text{in}}'' - E_{\text{out}}'' = \Delta E_{\text{st}}'' = E_f'' - E_i'' \quad \text{with} \quad E_{\text{in}}'' = 0.$$

$$E_{\text{out}}'' = c_p \int_{-L}^{+L} (T_i - T_\infty) dx$$

$$E_{\text{out}}'' = \rho c_p \int_{-L}^{+L} [a + bx + cx^2 - T_\infty] dx = \rho c_p \left[ ax + bx^2/2 + cx^3/3 - T_\infty x \right]_{-L}^{+L}$$

$$E_{\text{out}}'' = \rho c_p \left[ 2aL + 0 + 2cL^3/3 - 2T_\infty L \right]$$

$$E_{\text{out}}'' = 2600 \text{ kg/m}^3 \times 800 \text{ J/kg} \cdot \text{K} \left[ 2 \times 82^\circ\text{C} \times 0.020 \text{ m} + 2 \left( -2 \times 10^4 \text{ }^\circ\text{C/m}^2 \right) (0.020 \text{ m})^3 / 3 - 2(20^\circ\text{C})0.020 \text{ m} \right]$$

$$E_{\text{out}}'' = 4.94 \times 10^6 \text{ J/m}^2 \quad <$$

**COMMENTS:** (1) In part (a), note that the temperature gradient is larger at  $x = +L$  than at  $x = -L$ . This is consistent with the results of part (c) in which the conduction heat fluxes are evaluated.

Continued .....



### PROBLEM 2.32 (Cont.)

(2) In evaluating the conduction heat fluxes,  $q_x''(x)$ , it is important to recognize that this flux is in the positive  $x$ -direction. See how this convention is used in formulating the energy balance in part (c).

(3) It is good practice to represent energy balances with a schematic, clearly defining the system or surface, showing the CV or CS with dashed lines, and labeling the processes. Review again the features in the schematics for the energy balances of parts (c & d).

(4) Re-writing the heat diffusion equation introduced in part (b) as

$$-\frac{d}{dx}\left(-k\frac{dT}{dx}\right) + \dot{q} = 0$$

recognize that the term in parenthesis is the heat flux. From the differential equation, note that if the differential of this term is a constant ( $\dot{q}/k$ ), then the term must be a linear function of the  $x$ -coordinate. This agrees with the analysis of part (e).

(5) In part (f), we evaluated  $\dot{E}_{st}$ , the rate of energy change stored in the wall at the instant the volumetric heat generation was deactivated. Did you notice that  $\dot{E}_{st} = -2 \times 10^5 \text{ W/m}^3$  is the same value of the deactivated  $\dot{q}$ ? How do you explain this?

### PROBLEM 2.33

**KNOWN:** Transient temperature distributions in a plane wall.

**FIND:** Appropriate forms of heat equation, initial condition, and boundary conditions.

**SCHEMATIC:**

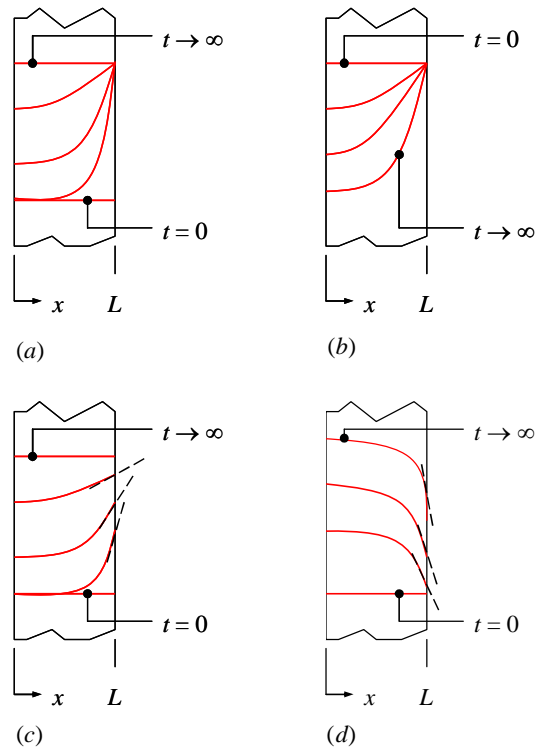

**ASSUMPTIONS:** (1) One-dimensional conduction, (2) Constant properties, (3) Negligible radiation.

**ANALYSIS:** The general form of the heat equation in Cartesian coordinates for constant  $k$  is Equation 2.21. For one-dimensional conduction it reduces to

$$\frac{\partial^2 T}{\partial x^2} + \frac{\dot{q}}{k} = \frac{1}{\alpha} \frac{\partial T}{\partial t}$$

At steady state this becomes

$$\frac{d^2 T}{dx^2} + \frac{\dot{q}}{k} = 0$$

If there is no thermal energy generation the steady-state temperature distribution is linear (or could be constant). If there is uniform thermal energy generation the steady-state temperature distribution must be parabolic.

Continued...

### PROBLEM 2.33 (Cont.)

In case (a), the steady-state temperature distribution is constant, therefore there must not be any thermal energy generation. The heat equation is

$$\frac{\partial^2 T}{\partial x^2} = \frac{1}{\alpha} \frac{\partial T}{\partial t} \quad <$$

The initial temperature is uniform throughout the solid, thus the initial condition is

$$T(x, 0) = T_i \quad <$$

At  $x = 0$ , the slope of the temperature distribution is zero at all times, therefore the heat flux is zero (insulated condition). The boundary condition is

$$\left. \frac{\partial T}{\partial x} \right|_{x=0} = 0 \quad <$$

At  $x = L$ , the temperature is the same for all  $t > 0$ . Therefore the surface temperature is constant:

$$T(L, t) = T_s \quad <$$

For case (b), the steady-state temperature distribution is not linear and appears to be parabolic, therefore there is thermal energy generation. The heat equation is

$$\frac{\partial^2 T}{\partial x^2} + \frac{\dot{q}}{k} = \frac{1}{\alpha} \frac{\partial T}{\partial t} \quad <$$

The initial temperature is uniform, the temperature gradient at  $x = 0$  is zero, and the temperature at  $x = L$  is equal to the initial temperature for all  $t > 0$ , therefore the initial and boundary conditions are

$$T(x, 0) = T_i, \quad \left. \frac{\partial T}{\partial x} \right|_{x=0} = 0, \quad T(L, t) = T_i \quad <$$

With the left side insulated and the right side maintained at the initial temperature, the cause of the decreasing temperature must be a negative value of thermal energy generation.

In case (c), the steady-state temperature distribution is constant, therefore there is no thermal energy generation. The heat equation is

$$\frac{\partial^2 T}{\partial x^2} = \frac{1}{\alpha} \frac{\partial T}{\partial t} \quad <$$

Continued...

### PROBLEM 2.33 (Cont.)

The initial temperature is uniform throughout the solid. At  $x = 0$ , the slope of the temperature distribution is zero at all times. Therefore the initial condition and boundary condition at  $x = 0$  are

$$T(x, 0) = T_i, \quad \left. \frac{\partial T}{\partial x} \right|_{x=0} = 0 \quad <$$

At  $x = L$ , neither the temperature nor the temperature gradient are constant for all time. Instead, the temperature gradient is decreasing with time as the temperature approaches the steady-state temperature. This corresponds to a convection heat transfer boundary condition. As the surface temperature approaches the fluid temperature, the heat flux at the surface decreases. The boundary condition is:

$$-k \left. \frac{\partial T}{\partial x} \right|_{x=L} = h [T(L, t) - T_\infty] \quad <$$

The fluid temperature,  $T_\infty$ , must be higher than the initial solid temperature to cause the solid temperature to increase.

For case (d), the steady-state temperature distribution is not linear and appears to be parabolic, therefore there is thermal energy generation. The heat equation is

$$\frac{\partial^2 T}{\partial x^2} + \frac{\dot{q}}{k} = \frac{1}{\alpha} \frac{\partial T}{\partial t} \quad <$$

Since the temperature is increasing with time and it is *not* due to heat conduction due to a high surface temperature, the energy generation must be positive.

The initial temperature is uniform and the temperature gradient at  $x = 0$  is zero. The boundary condition at  $x = L$  is convection. The temperature gradient and heat flux at the surface are *increasing* with time as the thermal energy generation causes the temperature to rise further and further above the fluid temperature. The initial and boundary conditions are:

$$T(x, 0) = T_i, \quad \left. \frac{\partial T}{\partial x} \right|_{x=0} = 0, \quad -k \left. \frac{\partial T}{\partial x} \right|_{x=L} = h [T(L, t) - T_\infty] \quad <$$

**COMMENTS:** 1. You will learn to solve for the temperature distribution in transient conduction in Chapter 5. 2. Case (b) might correspond to a situation involving a spatially-uniform endothermic chemical reaction. Such situations, although they can occur, are not common.

### PROBLEM 2.34

**KNOWN:** Steady-state conduction with uniform internal energy generation in a plane wall; temperature distribution has quadratic form. Surface at  $x=0$  is prescribed and boundary at  $x=L$  is insulated.

**FIND:** (a) Calculate the internal energy generation rate,  $\dot{q}$ , by applying an overall energy balance to the wall, (b) Determine the coefficients  $a$ ,  $b$ , and  $c$ , by applying the boundary conditions to the prescribed form of the temperature distribution; plot the temperature distribution and label as Case 1, (c) Determine new values for  $a$ ,  $b$ , and  $c$  for conditions when the convection coefficient is halved, and the generation rate remains unchanged; plot the temperature distribution and label as Case 2; (d) Determine new values for  $a$ ,  $b$ , and  $c$  for conditions when the generation rate is doubled, and the convection coefficient remains unchanged ( $h = 500 \text{ W/m}^2\cdot\text{K}$ ); plot the temperature distribution and label as Case 3.

**SCHEMATIC:**

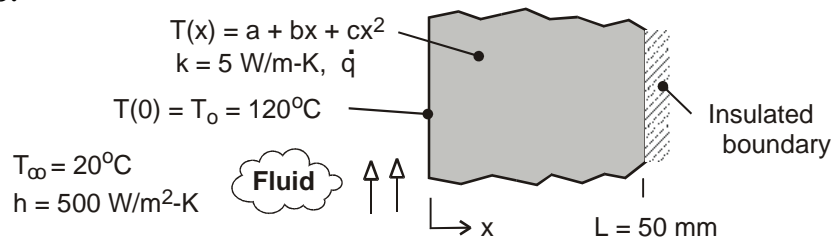

**ASSUMPTIONS:** (1) Steady-state conditions, (2) One-dimensional conduction with constant properties and uniform internal generation, and (3) Boundary at  $x=L$  is adiabatic.

**ANALYSIS:** (a) The internal energy generation rate can be calculated from an overall energy balance on the wall as shown in the schematic below.

$$\dot{E}_{\text{in}}'' - \dot{E}_{\text{out}}'' + \dot{E}_{\text{gen}}'' = 0 \quad \text{where} \quad \dot{E}_{\text{in}}'' = q_{\text{conv}}''$$

$$h(T_{\infty} - T_0) + \dot{q}L = 0 \quad (1)$$

$$\dot{q} = -h(T_{\infty} - T_0)/L = -500 \text{ W/m}^2 \cdot \text{K} (20 - 120)^\circ\text{C} / 0.050 \text{ m} = 1.0 \times 10^6 \text{ W/m}^3 <$$

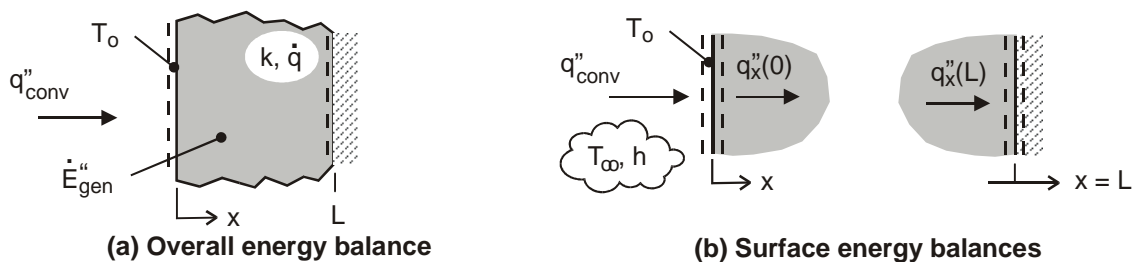

(b) The coefficients of the temperature distribution,  $T(x) = a + bx + cx^2$ , can be evaluated by applying the boundary conditions at  $x=0$  and  $x=L$ . See Table 2.2 for representation of the boundary conditions, and the schematic above for the relevant surface energy balances.

*Boundary condition at  $x=0$ , convection surface condition*

$$\dot{E}_{\text{in}}'' - \dot{E}_{\text{out}}'' = q_{\text{conv}}'' - q_x''(0) = 0 \quad \text{where} \quad q_x''(0) = -k \left. \frac{dT}{dx} \right|_{x=0}$$

$$h(T_{\infty} - T_0) - \left[ -k(0 + b + 2cx)_{x=0} \right] = 0$$

Continued ...

**PROBLEM 2.34 (Cont.)**

$$b = -h(T_\infty - T_o)/k = -500 \text{ W/m}^2 \cdot \text{K}(20 - 120)^\circ\text{C}/5 \text{ W/m} \cdot \text{K} = 1.0 \times 10^4 \text{ K/m} \quad (2) <$$

Boundary condition at  $x = L$ , adiabatic or insulated surface

$$\dot{E}_{\text{in}} - \dot{E}_{\text{out}} = -q_x''(L) = 0 \quad \text{where} \quad q_x''(L) = -k \left. \frac{dT}{dx} \right|_{x=L}$$

$$k[0 + b + 2cx]_{x=L} = 0 \quad (3)$$

$$c = -b/2L = -1.0 \times 10^4 \text{ K/m}/(2 \times 0.050\text{m}) = -1.0 \times 10^5 \text{ K/m}^2 \quad <$$

Since the surface temperature at  $x = 0$  is known,  $T(0) = T_o = 120^\circ\text{C}$ , find

$$T(0) = 120^\circ\text{C} = a + b \cdot 0 + c \cdot 0 \quad \text{or} \quad a = 120^\circ\text{C} \quad (4) <$$

Using the foregoing coefficients with the expression for  $T(x)$  in the Workspace of IHT, the temperature distribution can be determined and is plotted as Case 1 in the graph below.

(c) Consider Case 2 when the convection coefficient is halved,  $h_2 = h/2 = 250 \text{ W/m}^2 \cdot \text{K}$ ,  $\dot{q} = 1 \times 10^6 \text{ W/m}^3$  and other parameters remain unchanged except that  $T_o \neq 120^\circ\text{C}$ . We can determine  $a$ ,  $b$ , and  $c$  for the temperature distribution expression by repeating the analyses of parts (a) and (b).

Overall energy balance on the wall, see Eqs. (1,4)

$$a = T_o = \dot{q}L/h + T_\infty = 1 \times 10^6 \text{ W/m}^3 \times 0.050\text{m}/250 \text{ W/m}^2 \cdot \text{K} + 20^\circ\text{C} = 220^\circ\text{C} \quad <$$

Surface energy balance at  $x = 0$ , see Eq. (2)

$$b = -h(T_\infty - T_o)/k = -250 \text{ W/m}^2 \cdot \text{K}(20 - 220)^\circ\text{C}/5 \text{ W/m} \cdot \text{K} = 1.0 \times 10^4 \text{ K/m} \quad <$$

Surface energy balance at  $x = L$ , see Eq. (3)

$$c = -b/2L = -1.0 \times 10^4 \text{ K/m}/(2 \times 0.050\text{m}) = -1.0 \times 10^5 \text{ K/m}^2 \quad <$$

The new temperature distribution,  $T_2(x)$ , is plotted as Case 2 below.

(d) Consider Case 3 when the internal energy volumetric generation rate is doubled,  $\dot{q}_3 = 2\dot{q} = 2 \times 10^6 \text{ W/m}^3$ ,  $h = 500 \text{ W/m}^2 \cdot \text{K}$ , and other parameters remain unchanged except that  $T_o \neq 120^\circ\text{C}$ . Following the same analysis as part (c), the coefficients for the new temperature distribution,  $T(x)$ , are

$$a = 220^\circ\text{C} \quad b = 2 \times 10^4 \text{ K/m} \quad c = -2 \times 10^5 \text{ K/m}^2 \quad <$$

and the distribution is plotted as Case 3 below.

Continued ...

### PROBLEM 2.34 (Cont.)

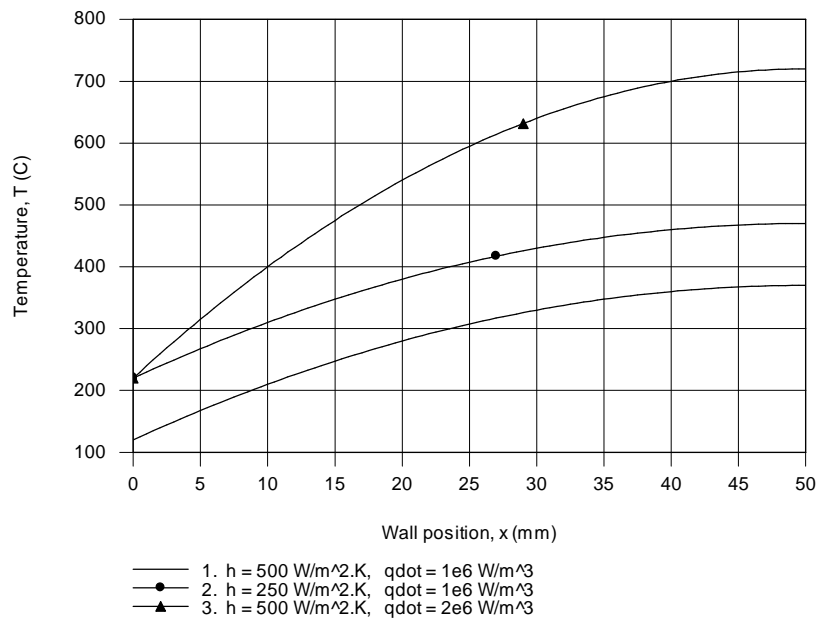

**COMMENTS:** Note the following features in the family of temperature distributions plotted above. The temperature gradients at  $x = L$  are zero since the boundary is insulated (adiabatic) for all cases. The shapes of the distributions are all quadratic, with the maximum temperatures at the insulated boundary.

By halving the convection coefficient for Case 2, we expect the surface temperature  $T_o$  to increase relative to the Case 1 value, since the same heat flux is removed from the wall ( $\dot{q}L$ ) but the convection resistance has increased.

By doubling the generation rate for Case 3, we expect the surface temperature  $T_o$  to increase relative to the Case 1 value, since double the amount of heat flux is removed from the wall ( $2\dot{q}L$ ).

Can you explain why  $T_o$  is the same for Cases 2 and 3, yet the insulated boundary temperatures are quite different? Can you explain the relative magnitudes of  $T(L)$  for the three cases?

### PROBLEM 2.35

**KNOWN:** Three-dimensional system – described by cylindrical coordinates  $(r, \phi, z)$  – experiences transient conduction and internal heat generation.

**FIND:** Heat diffusion equation.

**SCHEMATIC:** See also Fig. 2.12.

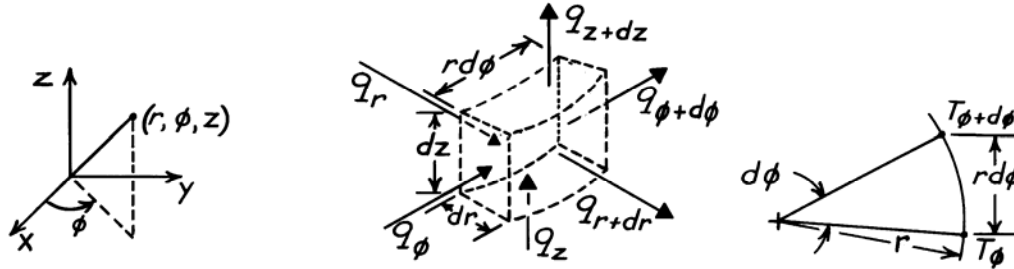

**ASSUMPTIONS:** (1) Homogeneous medium.

**ANALYSIS:** Consider the differential control volume identified above having a volume given as  $V = dr \cdot r d\phi \cdot dz$ . From the conservation of energy requirement,

$$q_r - q_{r+dr} + q_\phi - q_{\phi+d\phi} + q_z - q_{z+dz} + \dot{E}_g = \dot{E}_{st}. \quad (1)$$

The generation and storage terms, both representing volumetric phenomena, are

$$\dot{E}_g = \dot{q}V = \dot{q}(dr \cdot r d\phi \cdot dz) \quad \dot{E}_g = \rho V c \partial T / \partial t = \rho(dr \cdot r d\phi \cdot dz) c \partial T / \partial t. \quad (2,3)$$

Using a Taylor series expansion, we can write

$$q_{r+dr} = q_r + \frac{\partial}{\partial r}(q_r)dr, \quad q_{\phi+d\phi} = q_\phi + \frac{\partial}{\partial \phi}(q_\phi)d\phi, \quad q_{z+dz} = q_z + \frac{\partial}{\partial z}(q_z)dz. \quad (4,5,6)$$

Using Fourier's law, the expressions for the conduction heat rates are

$$q_r = -kA_r \partial T / \partial r = -k(r d\phi \cdot dz) \partial T / \partial r \quad (7)$$

$$q_\phi = -kA_\phi \partial T / r \partial \phi = -k(dr \cdot dz) \partial T / r \partial \phi \quad (8)$$

$$q_z = -kA_z \partial T / \partial z = -k(dr \cdot r d\phi) \partial T / \partial z. \quad (9)$$

Note from the above, right schematic that the gradient in the  $\phi$ -direction is  $\partial T / r \partial \phi$  and not  $\partial T / \partial \phi$ . Substituting Eqs. (2), (3) and (4), (5), (6) into Eq. (1),

$$-\frac{\partial}{\partial r}(q_r)dr - \frac{\partial}{\partial \phi}(q_\phi)d\phi - \frac{\partial}{\partial z}(q_z)dz + \dot{q} dr \cdot r d\phi \cdot dz = \rho(dr \cdot r d\phi \cdot dz) c \frac{\partial T}{\partial t}. \quad (10)$$

Substituting Eqs. (7), (8) and (9) for the conduction rates, find

$$\begin{aligned} -\frac{\partial}{\partial r} \left[ -k(r d\phi \cdot dz) \frac{\partial T}{\partial r} \right] dr - \frac{\partial}{\partial \phi} \left[ -k(dr dz) \frac{\partial T}{r \partial \phi} \right] d\phi - \frac{\partial}{\partial z} \left[ -k(dr \cdot r d\phi) \frac{\partial T}{\partial z} \right] dz \\ + \dot{q} dr \cdot r d\phi \cdot dz = \rho(dr \cdot r d\phi \cdot dz) c \frac{\partial T}{\partial t}. \end{aligned} \quad (11)$$

Dividing Eq. (11) by the volume of the CV, Eq. 2.26 is obtained.

$$\frac{1}{r} \frac{\partial}{\partial r} \left[ kr \frac{\partial T}{\partial r} \right] + \frac{1}{r^2} \frac{\partial}{\partial \phi} \left[ k \frac{\partial T}{\partial \phi} \right] + \frac{\partial}{\partial z} \left[ k \frac{\partial T}{\partial z} \right] + \dot{q} = \rho c \frac{\partial T}{\partial t} \quad <$$



## PROBLEM 2.36

**KNOWN:** Three-dimensional system – described by spherical coordinates  $(r, \phi, \theta)$  – experiences transient conduction and internal heat generation.

**FIND:** Heat diffusion equation.

**SCHEMATIC:** See Figure 2.13.

**ASSUMPTIONS:** (1) Homogeneous medium.

**ANALYSIS:** The differential control volume is  $V = dr \cdot r \sin \theta d\phi \cdot r d\theta$ , and the conduction terms are identified in Figure 2.13. Conservation of energy requires

$$q_r - q_{r+dr} + q_\phi - q_{\phi+d\phi} + q_\theta - q_{\theta+d\theta} + \dot{E}_g = \dot{E}_{st}. \quad (1)$$

The generation and storage terms, both representing volumetric phenomena, are

$$\dot{E}_g = \dot{q}V = \dot{q}[dr \cdot r \sin \theta d\phi \cdot r d\theta] \quad \dot{E}_{st} = \rho V c \frac{\partial T}{\partial t} = \rho[dr \cdot r \sin \theta d\phi \cdot r d\theta] c \frac{\partial T}{\partial t}. \quad (2,3)$$

Using a Taylor series expansion, we can write

$$q_{r+dr} = q_r + \frac{\partial}{\partial r}(q_r)dr, \quad q_{\phi+d\phi} = q_\phi + \frac{\partial}{\partial \phi}(q_\phi)d\phi, \quad q_{\theta+d\theta} = q_\theta + \frac{\partial}{\partial \theta}(q_\theta)d\theta. \quad (4,5,6)$$

From Fourier's law, the conduction heat rates have the following forms.

$$q_r = -kA_r \partial T / \partial r = -k[r \sin \theta d\phi \cdot r d\theta] \partial T / \partial r \quad (7)$$

$$q_\phi = -kA_\phi \partial T / r \sin \theta \partial \phi = -k[dr \cdot r d\theta] \partial T / r \sin \theta \partial \phi \quad (8)$$

$$q_\theta = -kA_\theta \partial T / r \partial \theta = -k[dr \cdot r \sin \theta d\phi] \partial T / r \partial \theta. \quad (9)$$

Substituting Eqs. (2), (3) and (4), (5), (6) into Eq. (1), the energy balance becomes

$$-\frac{\partial}{\partial r}(q_r)dr - \frac{\partial}{\partial \phi}(q_\phi)d\phi - \frac{\partial}{\partial \theta}(q_\theta)d\theta + \dot{q}[dr \cdot r \sin \theta d\phi \cdot r d\theta] = \rho[dr \cdot r \sin \theta d\phi \cdot r d\theta] c \frac{\partial T}{\partial t} \quad (10)$$

Substituting Eqs. (7), (8) and (9) for the conduction rates, find

$$\begin{aligned} & -\frac{\partial}{\partial r} \left[ -k[r \sin \theta d\phi \cdot r d\theta] \frac{\partial T}{\partial r} \right] dr - \frac{\partial}{\partial \phi} \left[ -k[dr \cdot r d\theta] \frac{\partial T}{r \sin \theta \partial \phi} \right] d\phi \\ & -\frac{\partial}{\partial \theta} \left[ -k[dr \cdot r \sin \theta d\phi] \frac{\partial T}{r \partial \theta} \right] d\theta + \dot{q}[dr \cdot r \sin \theta d\phi \cdot r d\theta] = \rho[dr \cdot r \sin \theta d\phi \cdot r d\theta] c \frac{\partial T}{\partial t} \end{aligned} \quad (11)$$

Dividing Eq. (11) by the volume of the control volume,  $V$ , Eq. 2.29 is obtained.

$$\frac{1}{r^2} \frac{\partial}{\partial r} \left[ kr^2 \frac{\partial T}{\partial r} \right] + \frac{1}{r^2 \sin^2 \theta} \frac{\partial}{\partial \phi} \left[ k \frac{\partial T}{\partial \phi} \right] + \frac{1}{r^2 \sin \theta} \frac{\partial}{\partial \theta} \left[ k \sin \theta \frac{\partial T}{\partial \theta} \right] + \dot{q} = \rho c \frac{\partial T}{\partial t}. \quad <$$

**COMMENTS:** Note how the temperature gradients in Eqs. (7) - (9) are formulated. The numerator is always  $\partial T$  while the denominator is the dimension of the control volume in the specified coordinate direction.

### PROBLEM 2.37

**KNOWN:** Temperature distribution in a semi-transparent medium subjected to radiative flux.

**FIND:** (a) Expressions for the heat flux at the front and rear surfaces, (b) Heat generation rate  $\dot{q}(x)$ ,  
(c) Expression for absorbed radiation per unit surface area in terms of  $A$ ,  $a$ ,  $B$ ,  $C$ ,  $L$ , and  $k$ .

**SCHEMATIC:**

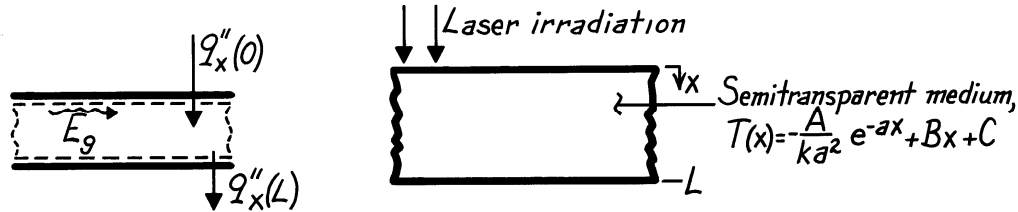

**ASSUMPTIONS:** (1) Steady-state conditions, (2) One-dimensional conduction in medium, (3) Constant properties, (4) All laser irradiation is absorbed and can be characterized by an internal volumetric heat generation term  $\dot{q}(x)$ .

**ANALYSIS:** (a) Knowing the temperature distribution, the surface heat fluxes are found using Fourier's law,

$$q''_x = -k \left[ \frac{dT}{dx} \right] = -k \left[ -\frac{A}{ka^2} (-a) e^{-ax} + B \right]$$

$$\text{Front Surface, } x=0: \quad q''_x(0) = -k \left[ +\frac{A}{ka} \cdot 1 + B \right] = -\left[ \frac{A}{a} + kB \right] \quad <$$

$$\text{Rear Surface, } x=L: \quad q''_x(L) = -k \left[ +\frac{A}{ka} e^{-aL} + B \right] = -\left[ \frac{A}{a} e^{-aL} + kB \right]. \quad <$$

(b) The heat diffusion equation for the medium is

$$\frac{d}{dx} \left( \frac{dT}{dx} \right) + \frac{\dot{q}}{k} = 0 \quad \text{or} \quad \dot{q} = -k \frac{d}{dx} \left( \frac{dT}{dx} \right)$$

$$\dot{q}(x) = -k \frac{d}{dx} \left[ +\frac{A}{ka} e^{-ax} + B \right] = A e^{-ax}. \quad <$$

(c) Performing an energy balance on the medium,

$$\dot{E}_{\text{in}} - \dot{E}_{\text{out}} + \dot{E}_g = 0$$

recognize that  $\dot{E}_g$  represents the absorbed irradiation. On a unit area basis

$$\dot{E}_g = -\dot{E}_{\text{in}} + \dot{E}_{\text{out}} = -q''_x(0) + q''_x(L) = +\frac{A}{a} (1 - e^{-aL}). \quad <$$

Alternatively, evaluate  $\dot{E}_g$  by integration over the volume of the medium,

$$\dot{E}_g = \int_0^L \dot{q}(x) dx = \int_0^L A e^{-ax} dx = -\frac{A}{a} \left[ e^{-ax} \right]_0^L = \frac{A}{a} (1 - e^{-aL}).$$

### PROBLEM 2.38

**KNOWN:** Cylindrical shell under steady-state conditions with no energy generation.

**FIND:** Under what conditions is a linear temperature distribution possible.

**SCHEMATIC:**

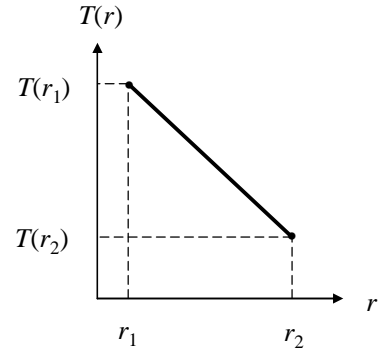
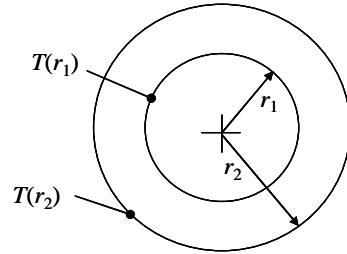

**ASSUMPTIONS:** (1) Steady state conditions. (2) One-dimensional conduction. (3) No internal energy generation.

**ANALYSIS:** Under the stated conditions, the heat equation in cylindrical coordinates, Equation 2.26, reduces to

$$\frac{d}{dr} \left( kr \frac{dT}{dr} \right) = 0$$

If the temperature distribution is a linear function of  $r$ , then the temperature gradient is constant, and this equation becomes

$$\frac{d}{dr} (kr) = 0$$

which implies  $kr = \text{constant}$ , or  $k \sim 1/r$ . The only way there could be a linear temperature distribution in the cylindrical shell is if the thermal conductivity were to vary inversely with  $r$ . <

**COMMENTS:** It is unlikely to encounter or even create a material for which  $k$  varies inversely with the cylindrical radial coordinate  $r$ . Assuming linear temperature distributions in radial systems is nearly always both fundamentally incorrect and physically implausible.

### PROBLEM 2.39

**KNOWN:** Spherical shell under steady-state conditions with no energy generation.

**FIND:** Under what conditions is a linear temperature distribution possible.

**SCHEMATIC:**

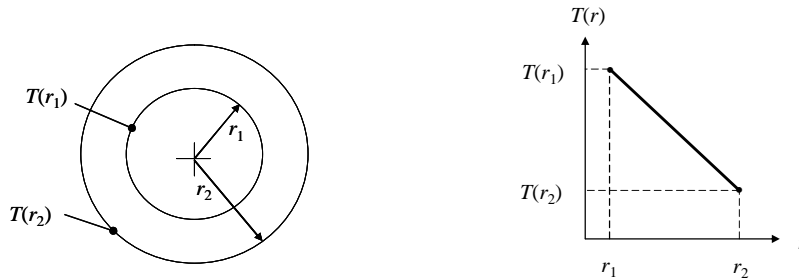

**ASSUMPTIONS:** (1) Steady state, (2) One-dimensional, (3) No heat generation.

**ANALYSIS:** Under the stated conditions, the heat equation in spherical coordinates, Equation 2.29, reduces to

$$\frac{d}{dr} \left( kr^2 \frac{dT}{dr} \right) = 0$$

If the temperature distribution is a linear function of  $r$ , then the temperature gradient is constant, and this equation becomes

$$\frac{d}{dr} (kr^2) = 0$$

which implies  $kr^2 = \text{constant}$ , or  $k \sim 1/r^2$ . The only way there could be a linear temperature distribution in the spherical shell is if the thermal conductivity were to vary inversely with  $r^2$ . <

**COMMENTS:** It is unlikely to encounter or even create a material for which  $k$  varies inversely with the spherical radial coordinate  $r$  in the manner necessary to develop a linear temperature distribution. Assuming linear temperature distributions in radial systems is nearly always both fundamentally incorrect and physically implausible.

### PROBLEM 2.40

**KNOWN:** Steady-state temperature distribution in a one-dimensional wall of thermal conductivity,  $T(x) = Ax^3 + Bx^2 + Cx + D$ .

**FIND:** Expressions for the heat generation rate in the wall and the heat fluxes at the two wall faces ( $x = 0, L$ ).

**ASSUMPTIONS:** (1) Steady-state conditions, (2) One-dimensional heat flow, (3) Homogeneous medium.

**ANALYSIS:** The appropriate form of the heat diffusion equation for these conditions is

$$\frac{d^2T}{dx^2} + \frac{\dot{q}}{k} = 0 \quad \text{or} \quad \dot{q} = -k \frac{d^2T}{dx^2}.$$

Hence, the generation rate is

$$\dot{q} = -k \frac{d}{dx} \left[ \frac{dT}{dx} \right] = -k \frac{d}{dx} [3Ax^2 + 2Bx + C + 0]$$

$$\dot{q} = -k[6Ax + 2B] \quad <$$

which is linear with the coordinate  $x$ . The heat fluxes at the wall faces can be evaluated from Fourier's law,

$$q_x'' = -k \frac{dT}{dx} = -k [3Ax^2 + 2Bx + C]$$

using the expression for the temperature gradient derived above. Hence, the heat fluxes are:

*Surface  $x=0$ :*

$$q_x''(0) = -kC \quad <$$

*Surface  $x=L$ :*

$$q_x''(L) = -k[3AL^2 + 2BL + C]. \quad <$$

**COMMENTS:** (1) From an overall energy balance on the wall, find

$$\dot{E}_{in}'' - \dot{E}_{out}'' + \dot{E}_g'' = 0$$

$$q_x''(0) - q_x''(L) + \dot{E}_g'' = (-kC) - (-k)[3AL^2 + 2BL + C] + \dot{E}_g'' = 0$$

$$\dot{E}_g'' = -3AkL^2 - 2BkL.$$

From integration of the volumetric heat rate, we can also find  $\dot{E}_g''$  as

$$\dot{E}_g'' = \int_0^L \dot{q}(x) dx = \int_0^L -k[6Ax + 2B] dx = -k \left[ 3Ax^2 + 2Bx \right]_0^L$$

$$\dot{E}_g'' = -3AkL^2 - 2BkL.$$

## PROBLEM 2.41

**KNOWN:** Plane wall with no internal energy generation.

**FIND:** Determine whether the prescribed temperature distribution is possible; explain your reasoning. With the temperatures  $T(0) = 0^\circ\text{C}$  and  $T_\infty = 20^\circ\text{C}$  fixed, compute and plot the temperature  $T(L)$  as a function of the convection coefficient for the range  $10 \leq h \leq 100 \text{ W/m}^2\cdot\text{K}$ .

**SCHEMATIC:**

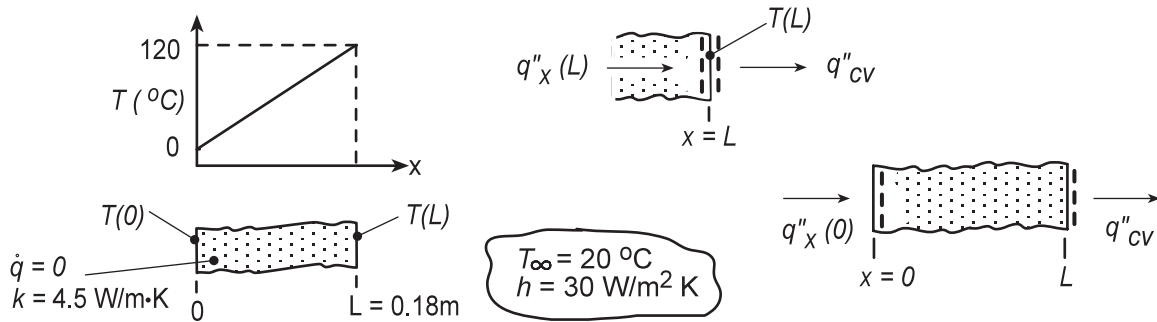

**ASSUMPTIONS:** (1) One-dimensional conduction, (2) No internal energy generation, (3) Constant properties, (4) No radiation exchange at the surface  $x = L$ , and (5) Steady-state conditions.

**ANALYSIS:** (a) Is the prescribed temperature distribution possible? If so, the energy balance at the surface  $x = L$  as shown above in the Schematic, must be satisfied.

$$\dot{E}_{\text{in}} - \dot{E}_{\text{out}} = 0 \quad q''_x(L) - q''_{\text{cv}} = 0 \quad (1,2)$$

where the conduction and convection heat fluxes are, respectively,

$$q''_x(L) = -k \left. \frac{dT}{dx} \right|_{x=L} = -k \frac{T(L) - T(0)}{L} = -4.5 \text{ W/m} \cdot \text{K} \times (120 - 0)^\circ\text{C} / 0.18 \text{ m} = -3000 \text{ W/m}^2$$

$$q''_{\text{cv}} = h [T(L) - T_\infty] = 30 \text{ W/m}^2 \cdot \text{K} \times (120 - 20)^\circ\text{C} = 3000 \text{ W/m}^2$$

Substituting the heat flux values into Eq. (2), find  $(-3000) - (3000) \neq 0$  and therefore, the temperature distribution is not possible.

(b) With  $T(0) = 0^\circ\text{C}$  and  $T_\infty = 20^\circ\text{C}$ , the temperature at the surface  $x = L$ ,  $T(L)$ , can be determined from an overall energy balance on the wall as shown above in the schematic,

$$\dot{E}_{\text{in}} - \dot{E}_{\text{out}} = 0 \quad q''_x(0) - q''_{\text{cv}} = 0 \quad -k \frac{T(L) - T(0)}{L} - h [T(L) - T_\infty] = 0$$

$$-4.5 \text{ W/m} \cdot \text{K} \left[ T(L) - 0^\circ\text{C} \right] / 0.18 \text{ m} - 30 \text{ W/m}^2 \cdot \text{K} \left[ T(L) - 20^\circ\text{C} \right] = 0$$

$$T(L) = 10.9^\circ\text{C}$$

Using this same analysis,  $T(L)$  as a function of the convection coefficient can be determined and plotted. We don't expect  $T(L)$  to be linearly dependent upon  $h$ . Note that as  $h$  increases to larger values,  $T(L)$  approaches  $T_\infty$ . To what value will  $T(L)$  approach as  $h$  decreases?

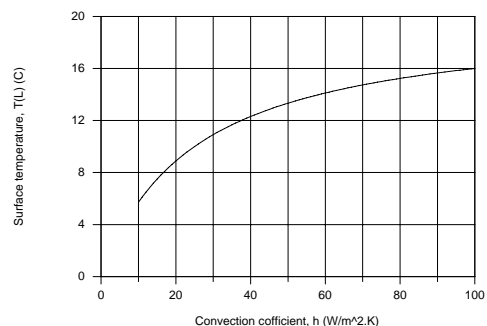

<

## PROBLEM 2.42

**KNOWN:** Coal pile of prescribed depth experiencing uniform volumetric generation with convection, absorbed irradiation and emission on its upper surface.

**FIND:** (a) The appropriate form of the heat diffusion equation (HDE) and whether the prescribed temperature distribution satisfies this HDE; conditions at the bottom of the pile,  $x = 0$ ; sketch of the temperature distribution with labeling of key features; (b) Expression for the conduction heat rate at the location  $x = L$ ; expression for the surface temperature  $T_s$  based upon a surface energy balance at  $x = L$ ; evaluate  $T_s$  and  $T(0)$  for the prescribed conditions; (c) Based upon typical daily averages for  $G_s$  and  $h$ , compute and plot  $T_s$  and  $T(0)$  for (1)  $h = 5 \text{ W/m}^2 \cdot \text{K}$  with  $50 \leq G_s \leq 500 \text{ W/m}^2$ , (2)  $G_s = 400 \text{ W/m}^2$  with  $5 \leq h \leq 50 \text{ W/m}^2 \cdot \text{K}$ .

**SCHEMATIC:**

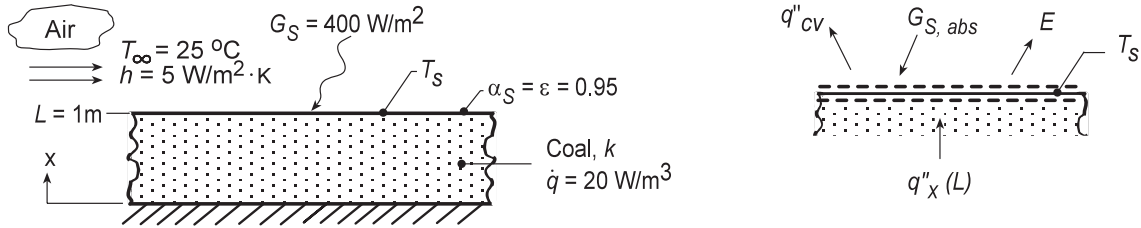

**ASSUMPTIONS:** (1) One-dimensional conduction, (2) Uniform volumetric heat generation, (3) Constant properties, (4) Negligible irradiation from the surroundings, and (5) Steady-state conditions.

**PROPERTIES:** Table A.3, Coal (300K):  $k = 0.26 \text{ W/m.K}$

**ANALYSIS:** (a) For one-dimensional, steady-state conduction with uniform volumetric heat generation and constant properties the heat diffusion equation (HDE) follows from Eq. 2.22,

$$\frac{d}{dx} \left( \frac{dT}{dx} \right) + \frac{\dot{q}}{k} = 0 \quad (1) <$$

Substituting the temperature distribution into the HDE, Eq. (1),

$$T(x) = T_s + \frac{\dot{q}L^2}{2k} \left( 1 - \frac{x^2}{L^2} \right) \quad \frac{d}{dx} \left[ 0 + \frac{\dot{q}L^2}{2k} \left( 0 - \frac{2x}{L^2} \right) \right] + \frac{\dot{q}}{k} = ? = 0 \quad (2,3) <$$

we find that it does indeed satisfy the HDE for all values of  $x$ . <

From Eq. (2), note that the temperature distribution must be quadratic, with maximum value at  $x = 0$ . At  $x = 0$ , the heat flux is

$$q''_x(0) = -k \left. \frac{dT}{dx} \right|_{x=0} = -k \left[ 0 + \frac{\dot{q}L^2}{2k} \left( 0 - \frac{2x}{L^2} \right) \right]_{x=0} = 0$$

so that the gradient at  $x = 0$  is zero. Hence, the bottom is insulated.

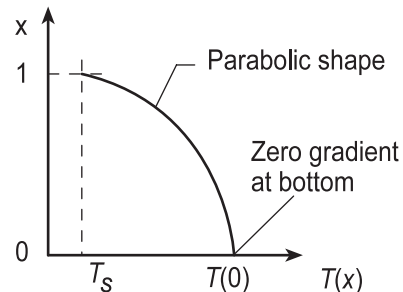

(b) From an overall energy balance on the pile, the conduction heat flux at the surface must be

$$q''_x(L) = \dot{E}_g = \dot{q}L \quad <$$

Continued...

### PROBLEM 2.42 (Cont.)

From a surface energy balance per unit area shown in the schematic above,

$$\dot{E}_{\text{in}} - \dot{E}_{\text{out}} + \dot{E}_g = 0 \quad q_x''(L) - q_{\text{conv}}'' + G_{S,\text{abs}} - E = 0$$

$$\dot{q}L - h(T_s - T_\infty) + 0.95G_S - \varepsilon\sigma T_s^4 = 0 \quad (4)$$

$$20 \text{ W/m}^3 \times 1 \text{ m} - 5 \text{ W/m}^2 \cdot \text{K} (T_s - 298 \text{ K}) + 0.95 \times 400 \text{ W/m}^2 - 0.95 \times 5.67 \times 10^{-8} \text{ W/m}^2 \cdot \text{K}^4 T_s^4 = 0$$

$$T_s = 295.7 \text{ K} = 22.7^\circ\text{C}$$

From Eq. (2) with  $x = 0$ , find

$$T(0) = T_s + \frac{\dot{q}L^2}{2k} = 22.7^\circ\text{C} + \frac{20 \text{ W/m}^3 \times (1 \text{ m})^2}{2 \times 0.26 \text{ W/m} \cdot \text{K}} = 61.1^\circ\text{C} \quad (5)$$

where the thermal conductivity for coal was obtained from Table A.3.

(c) Two plots are generated using Eq. (4) and (5) for  $T_s$  and  $T(0)$ , respectively; (1) with  $h = 5 \text{ W/m}^2 \cdot \text{K}$  for  $50 \leq G_S \leq 500 \text{ W/m}^2$  and (2) with  $G_S = 400 \text{ W/m}^2$  for  $5 \leq h \leq 50 \text{ W/m}^2 \cdot \text{K}$ .

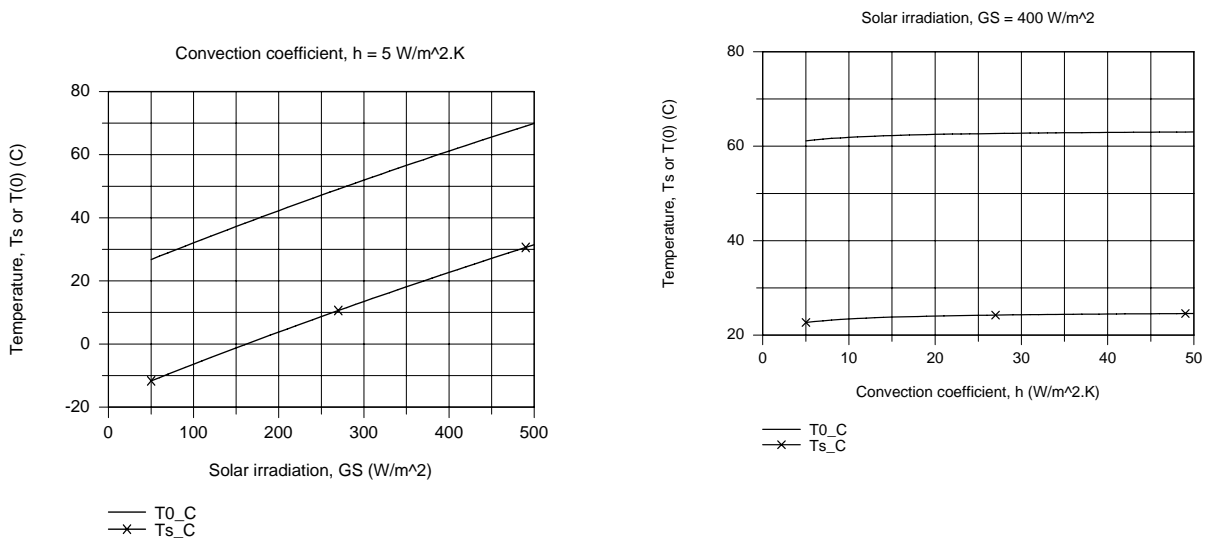

From the  $T$  vs.  $h$  plot with  $G_S = 400 \text{ W/m}^2$ , note that the convection coefficient does not have a major influence on the surface or bottom coal pile temperatures. From the  $T$  vs.  $G_S$  plot with  $h = 5 \text{ W/m}^2 \cdot \text{K}$ , note that the solar irradiation has a very significant effect on the temperatures. The fact that  $T_s$  is less than the ambient air temperature,  $T_\infty$ , and, in the case of very low values of  $G_S$ , below freezing, is a consequence of the large magnitude of the emissive power  $E$ .

**COMMENTS:** In our analysis we ignored irradiation from the sky, an environmental radiation effect you'll consider in Chapter 12. Treated as large isothermal surroundings,  $G_{\text{sky}} = \sigma T_{\text{sky}}^4$  where  $T_{\text{sky}} = -30^\circ\text{C}$  for very clear conditions and nearly air temperature for cloudy conditions. For low  $G_S$  conditions we should consider  $G_{\text{sky}}$ , the effect of which will be to predict higher values for  $T_s$  and  $T(0)$ .



## PROBLEM 2.43

**KNOWN:** Cylindrical system with negligible temperature variation in the  $r, z$  directions.

**FIND:** (a) Heat equation beginning with a properly defined control volume, (b) Temperature distribution  $T(\phi)$  for steady-state conditions with no internal heat generation and constant properties, (c) Heat rate for Part (b) conditions.

**SCHEMATIC:**

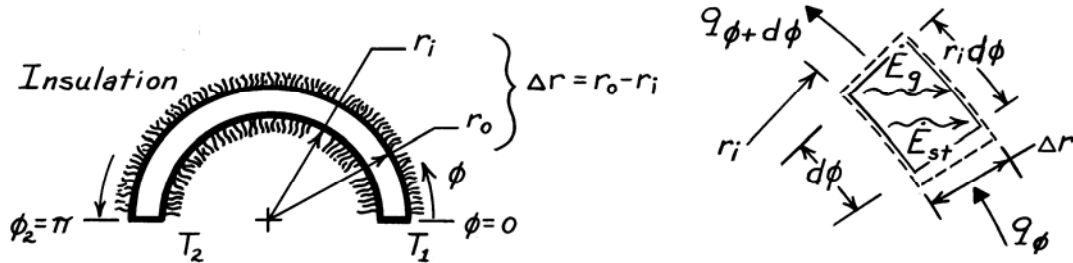

**ASSUMPTIONS:** (1)  $T$  is independent of  $r, z$ , (2)  $\Delta r = (r_o - r_i) \ll r_i$ .

**ANALYSIS:** (a) Define the control volume as  $V = r_i d\phi \cdot \Delta r \cdot L$  where  $L$  is length normal to page. Apply the conservation of energy requirement, Eq. 1.12c,

$$\dot{E}_{in} - \dot{E}_{out} + \dot{E}_g = \dot{E}_{st} \quad q_\phi - q_{\phi+d\phi} + \dot{q}V = \rho V c \frac{\partial T}{\partial t} \quad (1,2)$$

where

$$q_\phi = -k(\Delta r \cdot L) \frac{\partial T}{r_i \partial \phi} \quad q_{\phi+d\phi} = q_\phi + \frac{\partial}{\partial \phi}(q_\phi) d\phi. \quad (3,4)$$

Eqs. (3) and (4) follow from Fourier's law, Eq. 2.1, and from Eq. 2.25, respectively. Combining Eqs. (3) and (4) with Eq. (2) and canceling like terms, find

$$\frac{1}{r_i^2} \frac{\partial}{\partial \phi} \left( k \frac{\partial T}{\partial \phi} \right) + \dot{q} = \rho c \frac{\partial T}{\partial t}. \quad (5) <$$

Since temperature is independent of  $r$  and  $z$ , this form agrees with Eq. 2.26.

(b) For steady-state conditions with  $\dot{q} = 0$ , the heat equation, (5), becomes

$$\frac{d}{d\phi} \left[ k \frac{dT}{d\phi} \right] = 0. \quad (6)$$

With constant properties, it follows that  $dT/d\phi$  is constant which implies  $T(\phi)$  is linear in  $\phi$ . That is,

$$\frac{dT}{d\phi} = \frac{T_2 - T_1}{\phi_2 - \phi_1} = + \frac{1}{\pi} (T_2 - T_1) \quad \text{or} \quad T(\phi) = T_1 + \frac{1}{\pi} (T_2 - T_1) \phi. \quad (7,8) <$$

(c) The heat rate for the conditions of Part (b) follows from Fourier's law, Eq. (3), using the temperature gradient of Eq. (7). That is,

$$q_\phi = -k(\Delta r \cdot L) \frac{1}{r_i} \left[ + \frac{1}{\pi} (T_2 - T_1) \right] = -k \left[ \frac{r_o - r_i}{\pi r_i} \right] L (T_2 - T_1). \quad (9) <$$

**COMMENTS:** Note the expression for the temperature gradient in Fourier's law, Eq. (3), is  $\partial T / r_i \partial \phi$  not  $\partial T / \partial \phi$ . For the conditions of Parts (b) and (c), note that  $q_\phi$  is independent of  $\phi$ ; this is first indicated by Eq. (6) and confirmed by Eq. (9).

### PROBLEM 2.44

**KNOWN:** Heat diffusion with internal heat generation for one-dimensional cylindrical, radial coordinate system.

**FIND:** Heat diffusion equation.

**SCHEMATIC:**

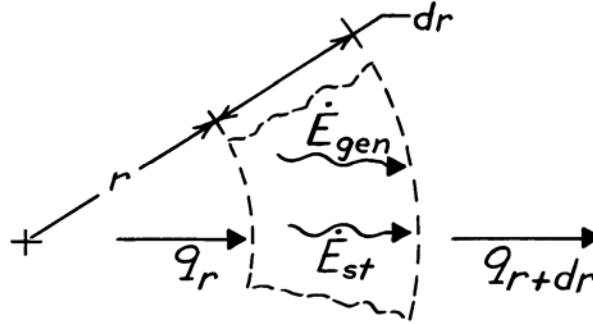

**ASSUMPTIONS:** (1) Homogeneous medium.

**ANALYSIS:** Control volume has volume,  $V = A_r \cdot dr = 2\pi \cdot r \cdot dr \cdot 1$ , with unit thickness normal to page. Using the conservation of energy requirement, Eq. 1.12c,

$$\dot{E}_{in} - \dot{E}_{out} + \dot{E}_{gen} = \dot{E}_{st}$$

$$q_r - q_{r+dr} + \dot{q}V = \rho V c_p \frac{\partial T}{\partial t}.$$

Fourier's law, Eq. 2.1, for this one-dimensional coordinate system is

$$q_r = -kA_r \frac{\partial T}{\partial r} = -k \times 2\pi r \cdot 1 \times \frac{\partial T}{\partial r}.$$

At the outer surface,  $r + dr$ , the conduction rate is

$$q_{r+dr} = q_r + \frac{\partial}{\partial r}(q_r)dr = q_r + \frac{\partial}{\partial r} \left[ -k \cdot 2\pi r \cdot \frac{\partial T}{\partial r} \right] dr.$$

Hence, the energy balance becomes

$$q_r - \left[ q_r + \frac{\partial}{\partial r} \left[ -k2\pi r \frac{\partial T}{\partial r} \right] dr \right] + \dot{q} \cdot 2\pi r dr = \rho \cdot 2\pi r dr \cdot c_p \frac{\partial T}{\partial t}$$

Dividing by the factor  $2\pi r dr$ , we obtain

$$\frac{1}{r} \frac{\partial}{\partial r} \left[ kr \frac{\partial T}{\partial r} \right] + \dot{q} = \rho c_p \frac{\partial T}{\partial t}.$$

<

**COMMENTS:** (1) Note how the result compares with Eq. 2.26 when the terms for the  $\phi, z$  coordinates are eliminated. (2) Recognize that we did not require  $\dot{q}$  and  $k$  to be independent of  $r$ .

### PROBLEM 2.45

**KNOWN:** Heat diffusion with internal heat generation for one-dimensional spherical, radial coordinate system.

**FIND:** Heat diffusion equation.

**SCHEMATIC:**

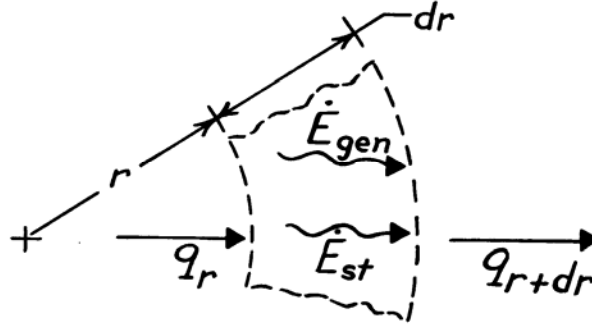

**ASSUMPTIONS:** (1) Homogeneous medium.

**ANALYSIS:** Control volume has the volume,  $V = A_r \cdot dr = 4\pi r^2 dr$ . Using the conservation of energy requirement, Eq. 1.12c,

$$\dot{E}_{in} - \dot{E}_{out} + \dot{E}_{gen} = \dot{E}_{st}$$

$$q_r - q_{r+dr} + \dot{q}V = \rho V c_p \frac{\partial T}{\partial t}.$$

Fourier's law, Eq. 2.1, for this coordinate system has the form

$$q_r = -kA_r \frac{\partial T}{\partial r} = -k \cdot 4\pi r^2 \cdot \frac{\partial T}{\partial r}.$$

At the outer surface,  $r + dr$ , the conduction rate is

$$q_{r+dr} = q_r + \frac{\partial}{\partial r}(q_r)dr = q_r + \frac{\partial}{\partial r} \left[ -k \cdot 4\pi r^2 \cdot \frac{\partial T}{\partial r} \right] dr.$$

Hence, the energy balance becomes

$$q_r - \left[ q_r + \frac{\partial}{\partial r} \left[ -k \cdot 4\pi r^2 \cdot \frac{\partial T}{\partial r} \right] dr \right] + \dot{q} \cdot 4\pi r^2 dr = \rho \cdot 4\pi r^2 dr \cdot c_p \frac{\partial T}{\partial t}.$$

Dividing by the factor  $4\pi r^2 dr$ , we obtain

$$\frac{1}{r^2} \frac{\partial}{\partial r} \left[ kr^2 \frac{\partial T}{\partial r} \right] + \dot{q} = \rho c_p \frac{\partial T}{\partial t}.$$

<

**COMMENTS:** (1) Note how the result compares with Eq. 2.29 when the terms for the  $\theta, \phi$  directions are eliminated.

(2) Recognize that we did not require  $\dot{q}$  and  $k$  to be independent of the coordinate  $r$ .

### PROBLEM 2.46

**KNOWN:** Temperature distribution in steam pipe insulation.

**FIND:** Whether conditions are steady-state or transient. Manner in which heat flux and heat rate vary with radius.

**SCHEMATIC:**

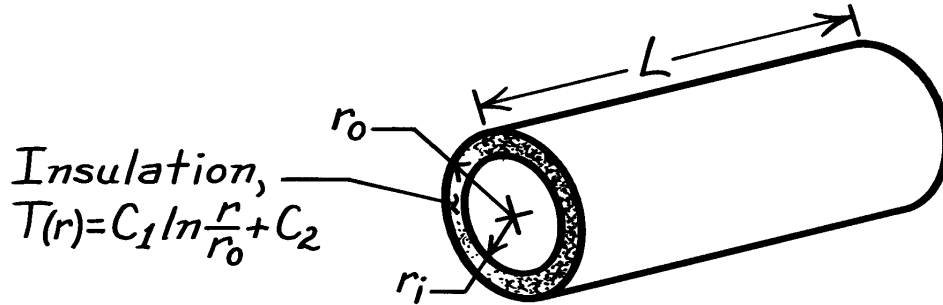

**ASSUMPTIONS:** (1) One-dimensional conduction in  $r$ , (2) Constant properties.

**ANALYSIS:** From Equation 2.26, the heat equation reduces to

$$\frac{1}{r} \frac{\partial}{\partial r} \left( r \frac{\partial T}{\partial r} \right) = \frac{1}{\alpha} \frac{\partial T}{\partial t}.$$

Substituting for  $T(r)$ ,

$$\frac{1}{\alpha} \frac{\partial T}{\partial t} = \frac{1}{r} \frac{\partial}{\partial r} \left( r \frac{C_1}{r} \right) = 0.$$

Hence, steady-state conditions exist. <

From Equation 2.23, the radial component of the heat flux is

$$q_r'' = -k \frac{\partial T}{\partial r} = -k \frac{C_1}{r}.$$

Hence,  $q_r''$  decreases with increasing  $r$  ( $q_r'' \propto 1/r$ ). <

At any radial location, the heat rate is

$$q_r = 2\pi L q_r'' = -2\pi k C_1 L$$

Hence,  $q_r$  is independent of  $r$ . <

**COMMENTS:** The requirement that  $q_r$  is invariant with  $r$  is consistent with the energy conservation requirement. If  $q_r$  is constant, the flux must vary inversely with the area perpendicular to the direction of heat flow. Hence,  $q_r''$  varies inversely with  $r$ .

## PROBLEM 2.47

**KNOWN:** Inner and outer radii and surface temperatures of a long circular tube with internal energy generation.

**FIND:** Conditions for which a linear radial temperature distribution may be maintained.

**SCHEMATIC:**

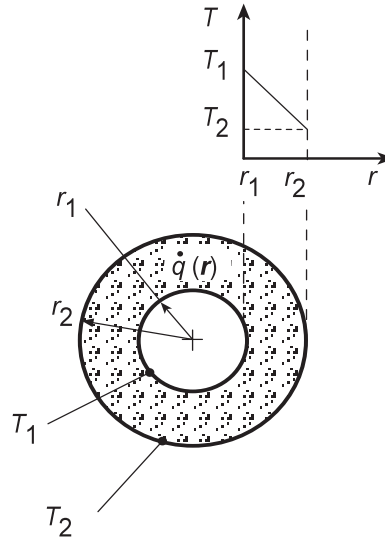

**ASSUMPTIONS:** (1) One-dimensional, steady-state conduction, (2) Constant properties.

**ANALYSIS:** For the assumed conditions, Eq. 2.26 reduces to

$$\frac{k}{r} \frac{d}{dr} \left( r \frac{dT}{dr} \right) + \dot{q} = 0$$

If  $\dot{q} = 0$  or  $\dot{q} = \text{constant}$ , it is clearly impossible to have a linear radial temperature distribution.

However, we may use the heat equation to infer a special form of  $\dot{q}(r)$  for which  $dT/dr$  is a constant (call it  $C_1$ ). It follows that

$$\begin{aligned} \frac{k}{r} \frac{d}{dr} (r C_1) + \dot{q} &= 0 \\ \dot{q} &= -\frac{C_1 k}{r} \end{aligned}$$

<

where  $C_1 = (T_2 - T_1)/(r_2 - r_1)$ . Hence, if the generation rate varies inversely with radial location, the radial temperature distribution is linear.

**COMMENTS:** Conditions for which  $\dot{q} \propto (1/r)$  would be unusual.

### PROBLEM 2.48

**KNOWN:** Radii and thermal conductivity of conducting rod and cladding material. Volumetric rate of thermal energy generation in the rod. Convection conditions at outer surface.

**FIND:** Heat equations and boundary conditions for rod and cladding.

**SCHEMATIC:**

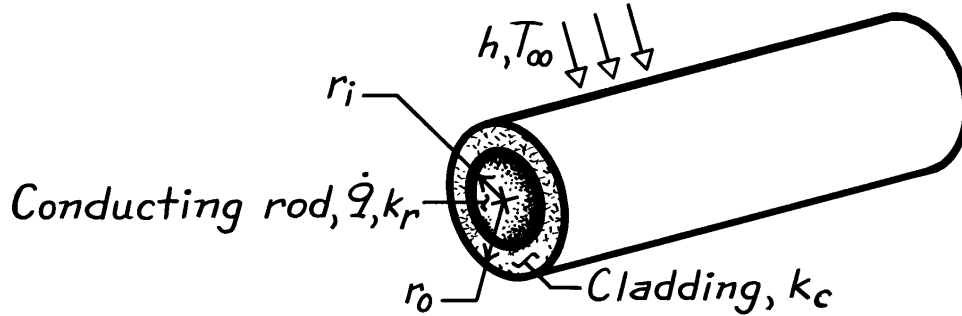

**ASSUMPTIONS:** (1) Steady-state conditions, (2) One-dimensional conduction in  $r$ , (3) Constant properties.

**ANALYSIS:** From Equation 2.26, the appropriate forms of the heat equation are

*Conducting Rod:*

$$\frac{k_r}{r} \frac{d}{dr} \left( r \frac{dT_r}{dr} \right) + \dot{q} = 0 \quad <$$

*Cladding:*

$$\frac{d}{dr} \left( r \frac{dT_c}{dr} \right) = 0. \quad <$$

Appropriate boundary conditions are:

$$(a) \quad \left. \frac{dT_r}{dr} \right|_{r=0} = 0 \quad <$$

$$(b) \quad T_r(r_i) = T_c(r_i) \quad <$$

$$(c) \quad k_r \left. \frac{dT_r}{dr} \right|_{r_i} = k_c \left. \frac{dT_c}{dr} \right|_{r_i} \quad <$$

$$(d) \quad -k_c \left. \frac{dT_c}{dr} \right|_{r_o} = h [T_c(r_o) - T_\infty] \quad <$$

**COMMENTS:** Condition (a) corresponds to symmetry at the centerline, while the interface conditions at  $r = r_i$  (b,c) correspond to requirements of thermal equilibrium and conservation of energy. Condition (d) results from conservation of energy at the outer surface. Note that contact resistance at the interface between the rod and cladding has been neglected.

## PROBLEM 2.49

**KNOWN:** Steady-state temperature distribution for hollow cylindrical solid with volumetric heat generation.

**FIND:** (a) Determine the inner radius of the cylinder,  $r_i$ , (b) Obtain an expression for the volumetric rate of heat generation,  $\dot{q}$ , (c) Determine the axial distribution of the heat flux at the outer surface,  $q_r''(r_o, z)$ , and the heat rate at this outer surface; is the heat rate *in* or *out* of the cylinder; (d) Determine the radial distribution of the heat flux at the end faces of the cylinder,  $q_z''(r, +z_o)$  and  $q_z''(r, -z_o)$ , and the corresponding heat rates; are the heat rates *in* or *out* of the cylinder; (e) Determine the relationship of the surface heat rates to the heat generation rate; is an overall energy balance satisfied?

**SCHEMATIC:**

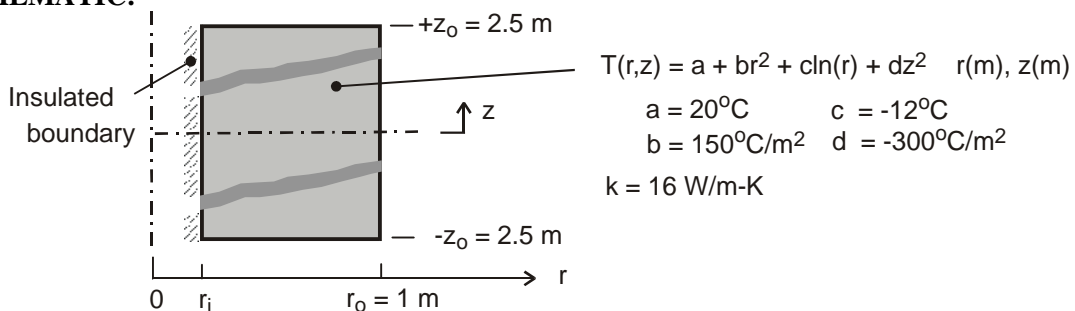

**ASSUMPTIONS:** (1) Steady-state conditions, (2) Two-dimensional conduction with constant properties and volumetric heat generation.

**ANALYSIS:** (a) Since the inner boundary,  $r = r_i$ , is adiabatic, then  $q_r''(r_i, z) = 0$ . Hence the temperature gradient in the  $r$ -direction must be zero.

$$\left. \frac{\partial T}{\partial r} \right|_{r_i} = 0 + 2br_i + c/r_i + 0 = 0$$

$$r_i = + \left( -\frac{c}{2b} \right)^{1/2} = \left( -\frac{-12^\circ\text{C}}{2 \times 150^\circ\text{C}/\text{m}^2} \right)^{1/2} = 0.2 \text{ m} \quad <$$

(b) To determine  $\dot{q}$ , substitute the temperature distribution into the heat diffusion equation, Eq. 2.26, for two-dimensional  $(r, z)$ , steady-state conduction

$$\frac{1}{r} \frac{\partial}{\partial r} \left( r \frac{\partial T}{\partial r} \right) + \frac{\partial}{\partial z} \left( \frac{\partial T}{\partial z} \right) + \frac{\dot{q}}{k} = 0$$

$$\frac{1}{r} \frac{\partial}{\partial r} (r[0 + 2br + c/r + 0]) + \frac{\partial}{\partial z} (0 + 0 + 0 + 2dz) + \frac{\dot{q}}{k} = 0$$

$$\frac{1}{r} [4br + 0] + 2d + \frac{\dot{q}}{k} = 0$$

$$\dot{q} = -k[4b + 2d] = -16 \text{ W}/\text{m}\cdot\text{K} [4 \times 150^\circ\text{C}/\text{m}^2 + 2(-300^\circ\text{C}/\text{m}^2)] = 0 \text{ W}/\text{m}^3 \quad <$$

(c) The heat flux and the heat rate at the outer surface,  $r = r_o$ , may be calculated using Fourier's law.

$$q_r''(r_o, z) = -k \left. \frac{\partial T}{\partial r} \right|_{r_o} = -k [0 + 2br_o + c/r_o + 0]$$

Continued ...

**PROBLEM 2.49 (Cont.)**

$$q_r''(r_o, z) = -16 \text{ W/m} \cdot \text{K} \left[ 2 \times 150^\circ\text{C/m}^2 \times 1 \text{ m} - 12^\circ\text{C/1 m} \right] = -4608 \text{ W/m}^2 \quad <$$

$$q_r(r_o) = A_r q_r''(r_o, z) \quad \text{where} \quad A_r = 2\pi r_o (2z_o)$$

$$q_r(r_o) = -4\pi \times 1 \text{ m} \times 2.5 \text{ m} \times 4608 \text{ W/m}^2 = -144,765 \text{ W} \quad <$$

Note that the sign of the heat flux and heat rate in the positive r-direction is negative, and hence the heat flow is *into* the cylinder.

(d) The heat fluxes and the heat rates at end faces,  $z = +z_o$  and  $-z_o$ , may be calculated using Fourier's law. The direction of the heat rate *in* or *out* of the end face is determined by the sign of the heat flux in the positive z-direction.

At the upper end face,  $z = +z_o$ : <

$$q_z''(r, +z_o) = -k \left. \frac{\partial T}{\partial z} \right|_{z_o} = -k [0 + 0 + 0 + 2dz_o]$$

$$q_z''(r, +z_o) = -16 \text{ W/m} \cdot \text{K} \times 2 \left( -300^\circ\text{C/m}^2 \right) 2.5 \text{ m} = +24,000 \text{ W/m}^2 \quad <$$

$$q_z(+z_o) = A_z q_z''(r, +z_o) \quad \text{where} \quad A_z = \pi (r_o^2 - r_i^2)$$

$$q_z(+z_o) = \pi (1^2 - 0.2^2) \text{ m}^2 \times 24,000 \text{ W/m}^2 = +72,382 \text{ W} \quad <$$

Thus, heat flows out of the cylinder.

At the lower end face,  $z = -z_o$ : <

$$q_z''(r, -z_o) = -k \left. \frac{\partial T}{\partial z} \right|_{-z_o} = -k [0 + 0 + 0 + 2d(-z_o)]$$

$$q_z''(r, -z_o) = -16 \text{ W/m}^2 \cdot \text{K} \times 2 \left( -300^\circ\text{C/m} \right) (-2.5 \text{ m}) = -24,000 \text{ W/m}^2 \quad <$$

$$q_z(-z_o) = -72,382 \text{ W} \quad <$$

Again, heat flows out of the cylinder.

(e) The heat rates from the surfaces and the volumetric heat generation can be related through an overall energy balance on the cylinder as shown in the sketch.

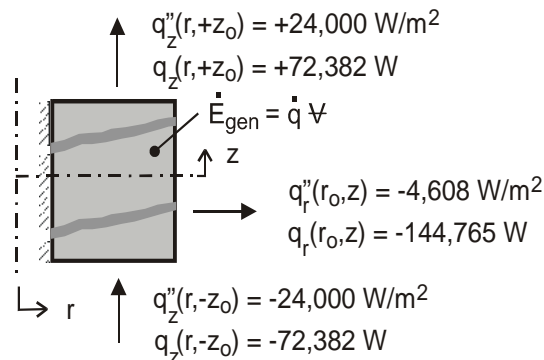

Continued...



**PROBLEM 2.49 (Cont.)**

$$\dot{E}_{\text{in}} - \dot{E}_{\text{out}} + \dot{E}_{\text{gen}} = 0 \quad \text{where} \quad \dot{E}_{\text{gen}} = \dot{q}\dot{V} = 0$$

$$\dot{E}_{\text{in}} = -q_r(r_o) = -(-144,765 \text{ W}) = +144,765 \text{ W} \quad <$$

$$\dot{E}_{\text{out}} = +q_z(z_o) - q_z(-z_o) = [72,382 - (-72,382)] \text{ W} = +144,764 \text{ W} \quad <$$

The overall energy balance is satisfied.

**COMMENTS:** When using Fourier's law, the heat flux  $q_z''$  denotes the heat flux in the positive z-direction. At a boundary, the sign of the numerical value will determine whether heat is flowing into or out of the boundary.

## PROBLEM 2.50

**KNOWN:** An electric cable with an insulating sleeve experiences convection with adjoining air and radiation exchange with large surroundings.

**FIND:** (a) Verify that prescribed temperature distributions for the cable and insulating sleeve satisfy their appropriate heat diffusion equations; sketch temperature distributions labeling key features; (b) Applying Fourier's law, verify the conduction heat rate expression for the sleeve,  $q'_r$ , in terms of  $T_{s,1}$  and  $T_{s,2}$ ; apply a surface energy balance to the cable to obtain an alternative expression for  $q'_r$  in terms of  $\dot{q}$  and  $r_1$ ; (c) Apply surface energy balance around the outer surface of the sleeve to obtain an expression for which  $T_{s,2}$  can be evaluated; (d) Determine  $T_{s,1}$ ,  $T_{s,2}$ , and  $T_o$  for the specified geometry and operating conditions; and (e) Plot  $T_{s,1}$ ,  $T_{s,2}$ , and  $T_o$  as a function of the outer radius for the range  $15.5 \leq r_2 \leq 20$  mm.

**SCHEMATIC:**

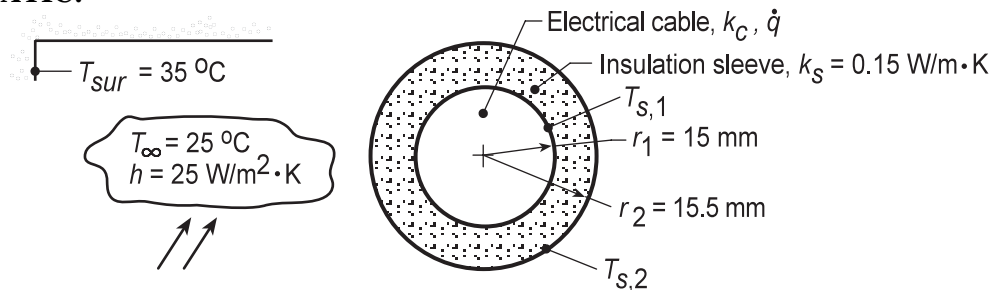

**ASSUMPTIONS:** (1) One-dimensional, radial conduction, (2) Uniform volumetric heat generation in cable, (3) Negligible thermal contact resistance between the cable and sleeve, (4) Constant properties in cable and sleeve, (5) Surroundings large compared to the sleeve, and (6) Steady-state conditions.

**ANALYSIS:** (a) The appropriate forms of the heat diffusion equation (HDE) for the insulation and cable are identified. The temperature distributions are valid if they satisfy the relevant HDE.

*Insulation:* The temperature distribution is given as

$$T(r) = T_{s,2} + (T_{s,1} - T_{s,2}) \frac{\ln(r/r_2)}{\ln(r_1/r_2)} \quad (1)$$

and the appropriate HDE (radial coordinates, SS,  $\dot{q} = 0$ ), Eq. 2.26,

$$\frac{d}{dr} \left( r \frac{dT}{dr} \right) = 0$$

$$\frac{d}{dr} \left( r \left[ 0 + (T_{s,1} - T_{s,2}) \frac{1/r}{\ln(r_1/r_2)} \right] \right) = \frac{d}{dr} \left( \frac{T_{s,1} - T_{s,2}}{\ln(r_1/r_2)} \right) = 0$$

Hence, the temperature distribution satisfies the HDE. <

Continued...

## PROBLEM 2.50 (Cont.)

*Cable:* The temperature distribution is given as

$$T(r) = T_{s,1} + \frac{\dot{q}r_1^2}{4k_c} \left( 1 - \frac{r^2}{r_1^2} \right) \quad (2)$$

and the appropriate HDE (radial coordinates, SS,  $\dot{q}$  uniform), Eq. 2.26,

$$\frac{1}{r} \frac{d}{dr} \left( r \frac{dT}{dr} \right) + \frac{\dot{q}}{k_c} = 0$$

$$\frac{1}{r} \frac{d}{dr} \left( r \left[ 0 + \frac{\dot{q}r_1^2}{4k_c} \left( 0 - \frac{2r}{r_1^2} \right) \right] \right) + \frac{\dot{q}}{k_c} = 0$$

$$\frac{1}{r} \frac{d}{dr} \left( -\frac{\dot{q}r_1^2}{4k_c} \frac{2r^2}{r_1^2} \right) + \frac{\dot{q}}{k_c} = 0$$

$$\frac{1}{r} \left( -\frac{\dot{q}r_1^2}{4k_c} \frac{4r}{r_1^2} \right) + \frac{\dot{q}}{k_c} = 0$$

Hence the temperature distribution satisfies the HDE. <

The temperature distributions in the cable,  $0 \leq r \leq r_1$ , and sleeve,  $r_1 \leq r \leq r_2$ , and their key features are as follows:

- (1) Zero gradient, symmetry condition,
- (2) Increasing gradient with increasing radius,  $r$ , because of  $\dot{q}$ ,
- (3) Discontinuous gradient of  $T(r)$  across cable-sleeve interface because of different thermal conductivities,
- (4) Decreasing gradient with increasing radius,  $r$ , since heat rate is constant.

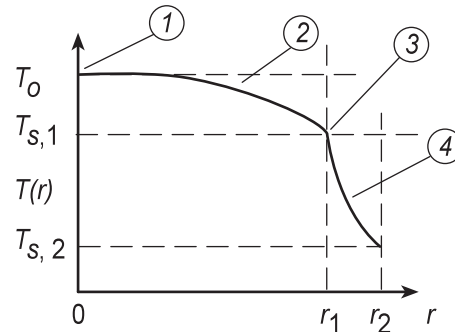

(b) Using Fourier's law for the radial-cylindrical coordinate, the heat rate through the *insulation* (sleeve) per unit length is

$$q'_r = -kA'_r \frac{dT}{dr} = -k2\pi r \frac{dT}{dr} \quad <$$

and substituting for the temperature distribution, Eq. (1),

$$q'_r = -k_s 2\pi r \left[ 0 + (T_{s,1} - T_{s,2}) \frac{1/r}{\ln(r_1/r_2)} \right] = 2\pi k_s \frac{(T_{s,1} - T_{s,2})}{\ln(r_2/r_1)} \quad (3) <$$

Applying an energy balance to a control surface placed around the cable,

Continued...

**PROBLEM 2.50 (Cont.)**

$$\dot{E}_{\text{in}} - \dot{E}_{\text{out}} = 0$$

$$\dot{q}\nabla_c - q'_r = 0$$

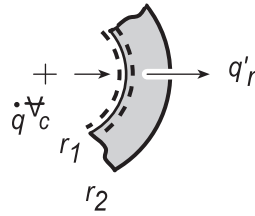

where  $\dot{q}\nabla_c$  represents the dissipated electrical power in the cable

$$\dot{q}(\pi r_1^2) - q'_r = 0 \quad \text{or} \quad q'_r = \pi \dot{q} r_1^2 \quad (4) <$$

(c) Applying an energy balance to a control surface placed around the outer surface of the sleeve,

$$\dot{E}_{\text{in}} - \dot{E}_{\text{out}} = 0$$

$$q'_r - q'_{\text{conv}} - q'_{\text{rad}} = 0$$

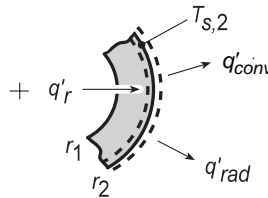

$$\pi \dot{q} r_1^2 - h(2\pi r_2)(T_{s,2} - T_\infty) - \varepsilon(2\pi r_2)\sigma(T_{s,2}^4 - T_{\text{sur}}^4) = 0 \quad (5) <$$

This relation can be used to determine  $T_{s,2}$  in terms of the variables  $\dot{q}$ ,  $r_1$ ,  $r_2$ ,  $h$ ,  $T_\infty$ ,  $\varepsilon$  and  $T_{\text{sur}}$ .

(d) Consider a cable-sleeve system with the following prescribed conditions:

$r_1 = 15 \text{ mm}$	$k_c = 200 \text{ W/m}\cdot\text{K}$	$h = 25 \text{ W/m}^2\cdot\text{K}$	$\varepsilon = 0.9$
$r_2 = 15.5 \text{ mm}$	$k_s = 0.15 \text{ W/m}\cdot\text{K}$	$T_\infty = 25^\circ\text{C}$	$T_{\text{sur}} = 35^\circ\text{C}$

For 250 A with  $R'_e = 0.005 \Omega/\text{m}$ , the volumetric heat generation rate is

$$\dot{q} = I^2 R'_e / \nabla_c = I^2 R'_e / (\pi r_1^2)$$

$$\dot{q} = (250 \text{ A})^2 \times 0.005 \Omega / \text{m} / (\pi \times 0.015^2 \text{ m}^2) = 4.42 \times 10^5 \text{ W/m}^3$$

Substituting numerical values in appropriate equations, we can evaluate  $T_{s,1}$ ,  $T_{s,2}$  and  $T_o$ .

*Sleeve outer surface temperature,  $T_{s,2}$ :* Using Eq. (5),

$$\begin{aligned} \pi \times 4.42 \times 10^5 \text{ W/m}^3 \times (0.015 \text{ m})^2 - 25 \text{ W/m}^2 \cdot \text{K} \times (2\pi \times 0.0155 \text{ m})(T_{s,2} - 298 \text{ K}) \\ - 0.9 \times (2\pi \times 0.0155 \text{ m}) \times 5.67 \times 10^{-8} \text{ W/m}^2 \cdot \text{K}^4 (T_{s,2}^4 - 308^4) \text{ K}^4 = 0 \end{aligned}$$

$$T_{s,2} = 395 \text{ K} = 122^\circ\text{C} \quad <$$

*Sleeve-cable interface temperature,  $T_{s,1}$ :* Using Eqs. (3) and (4), with  $T_{s,2} = 395 \text{ K}$ ,

Continued...

**PROBLEM 2.50 (Cont.)**

$$\pi \dot{q} r_1^2 = 2\pi k_s \frac{(T_{s,1} - T_{s,2})}{\ln(r_2/r_1)}$$

$$\pi \times 4.42 \times 10^5 \text{ W/m}^3 \times (0.015 \text{ m})^2 = 2\pi \times 0.15 \text{ W/m} \cdot \text{K} \frac{(T_{s,1} - 395 \text{ K})}{\ln(15.5/15.0)}$$

$$T_{s,1} = 406 \text{ K} = 133^\circ \text{C}$$

<

Cable centerline temperature,  $T_o$ : Using Eq. (2) with  $T_{s,1} = 133^\circ \text{C}$ ,

$$T_o = T(0) = T_{s,1} + \frac{\dot{q} r_1^2}{4k_c}$$

$$T_o = 133^\circ \text{C} + 4.42 \times 10^5 \text{ W/m}^3 \times (0.015 \text{ m})^2 / (4 \times 200 \text{ W/m} \cdot \text{K}) = 133.1^\circ \text{C}$$

<

(e) With all other conditions remaining the same, the relations of part (d) can be used to calculate  $T_o$ ,  $T_{s,1}$  and  $T_{s,2}$  as a function of the sleeve outer radius  $r_2$  for the range  $15.5 \leq r_2 \leq 20$  mm.

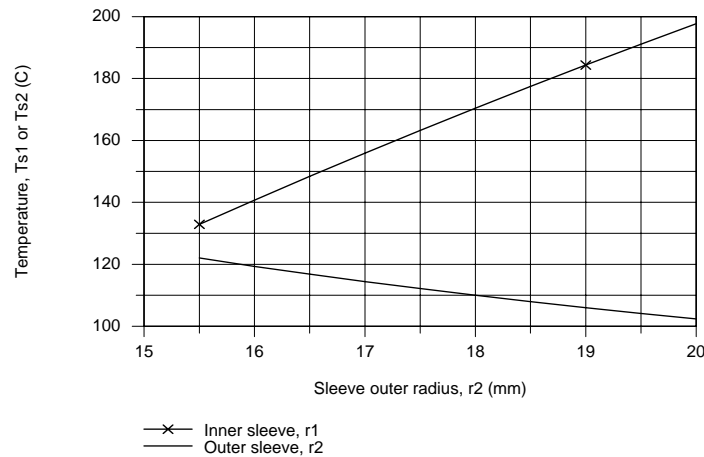

On the plot above  $T_o$  would show the same behavior as  $T_{s,1}$  since the temperature rise between cable center and its surface is  $0.12^\circ \text{C}$ . With increasing  $r_2$ , we expect  $T_{s,2}$  to decrease since the heat flux decreases with increasing  $r_2$ . We expect  $T_{s,1}$  to increase with increasing  $r_2$  since the thermal resistance of the sleeve increases.

## PROBLEM 2.51

**KNOWN:** Temperature distribution in a spherical shell.

**FIND:** Whether conditions are steady-state or transient. Manner in which heat flux and heat rate vary with radius.

**SCHEMATIC:**

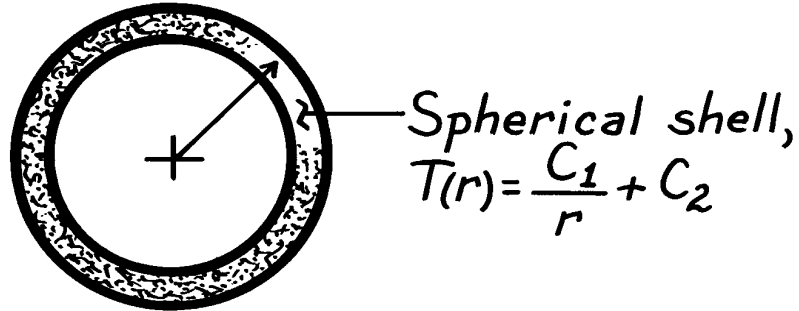

**ASSUMPTIONS:** (1) One-dimensional conduction in  $r$ , (2) Constant properties.

**ANALYSIS:** From Equation 2.29, the heat equation reduces to

$$\frac{1}{r^2} \frac{\partial}{\partial r} \left( r^2 \frac{\partial T}{\partial r} \right) = \frac{1}{\alpha} \frac{\partial T}{\partial t}.$$

Substituting for  $T(r)$ ,

$$\frac{1}{\alpha} \frac{\partial T}{\partial t} = -\frac{1}{r^2} \frac{\partial}{\partial r} \left( r^2 \frac{C_1}{r^2} \right) = 0.$$

Hence, steady-state conditions exist. <

From Equation 2.28, the radial component of the heat flux is

$$q_r'' = -k \frac{\partial T}{\partial r} = k \frac{C_1}{r^2}.$$

Hence,  $q_r''$  decreases with increasing  $r^2$  ( $q_r'' \propto 1/r^2$ ). <

At any radial location, the heat rate is

$$q_r = 4\pi r^2 q_r'' = 4\pi k C_1.$$

Hence,  $q_r$  is independent of  $r$ . <

**COMMENTS:** The fact that  $q_r$  is independent of  $r$  is consistent with the energy conservation requirement. If  $q_r$  is constant, the flux must vary inversely with the area perpendicular to the direction of heat flow. Hence,  $q_r''$  varies inversely with  $r^2$ .

## PROBLEM 2.52

**KNOWN:** Spherical container with an exothermic reaction enclosed by an insulating material whose outer surface experiences convection with adjoining air and radiation exchange with large surroundings.

**FIND:** (a) Verify that the prescribed temperature distribution for the insulation satisfies the appropriate form of the heat diffusion equation; sketch the temperature distribution and label key features; (b) Applying Fourier's law, verify the conduction heat rate expression for the insulation layer,  $q_r$ , in terms of  $T_{s,1}$  and  $T_{s,2}$ ; apply a surface energy balance to the container and obtain an alternative expression for  $q_r$  in terms of  $\dot{q}$  and  $r_1$ ; (c) Apply a surface energy balance around the outer surface of the insulation to obtain an expression to evaluate  $T_{s,2}$ ; (d) Determine  $T_{s,2}$  for the specified geometry and operating conditions; (e) Compute and plot the variation of  $T_{s,2}$  as a function of the outer radius for the range  $201 \leq r_2 \leq 210$  mm; explore approaches for reducing  $T_{s,2} \leq 45^\circ\text{C}$  to eliminate potential risk for burn injuries to personnel.

**SCHEMATIC:**

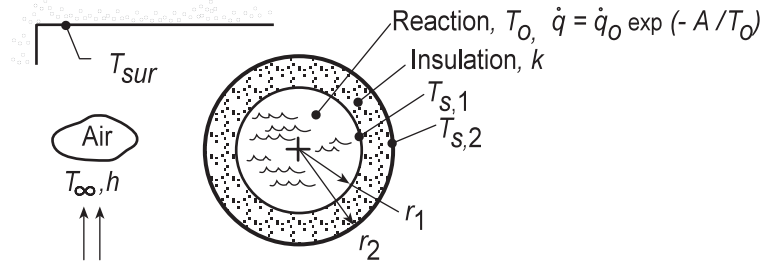

**ASSUMPTIONS:** (1) One-dimensional, radial spherical conduction, (2) Isothermal reaction in container so that  $T_o = T_{s,1}$ , (3) Negligible thermal contact resistance between the container and insulation, (4) Surroundings large compared to the insulated vessel, and (5) Steady-state conditions.

**ANALYSIS:** The appropriate form of the heat diffusion equation (HDE) for the insulation follows from Eq. 2.29,

$$\frac{1}{r^2} \frac{d}{dr} \left( r^2 \frac{dT}{dr} \right) = 0 \quad (1) <$$

The temperature distribution is given as

$$T(r) = T_{s,1} - (T_{s,1} - T_{s,2}) \left[ \frac{1 - (r_1/r)}{1 - (r_1/r_2)} \right] \quad (2)$$

Substitute  $T(r)$  into the HDE to see if it is satisfied:

$$\frac{1}{r^2} \frac{d}{dr} \left( r^2 \left[ 0 - (T_{s,1} - T_{s,2}) \frac{0 + (r_1/r^2)}{1 - (r_1/r_2)} \right] \right) = 0$$

$$\frac{1}{r^2} \frac{d}{dr} \left( + (T_{s,1} - T_{s,2}) \frac{r_1}{1 - (r_1/r_2)} \right) = 0 \quad <$$

and since the expression in parenthesis is independent of  $r$ ,  $T(r)$  does indeed satisfy the HDE. The temperature distribution in the insulation and its key features are as follows:

Continued...

**PROBLEM 2.52 (Cont.)**

- (1)  $T_{s,1} > T_{s,2}$   
 (2) Decreasing gradient with increasing radius,  $r$ , since the heat rate is constant through the insulation.

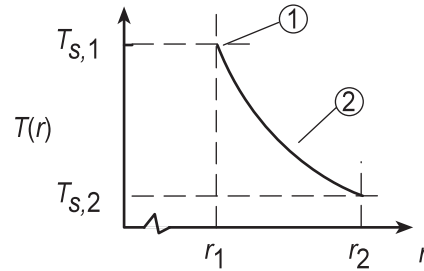

(b) Using Fourier's law for the radial-spherical coordinate, the heat rate through the insulation is

$$q_r = -kA_r \frac{dT}{dr} = -k(4\pi r^2) \frac{dT}{dr} \quad <$$

and substituting for the temperature distribution, Eq. (2),

$$q_r = -4k\pi r^2 \left[ 0 - (T_{s,1} - T_{s,2}) \frac{0 + (r_1/r^2)}{1 - (r_1/r_2)} \right]$$

$$q_r = \frac{4\pi k (T_{s,1} - T_{s,2})}{(1/r_1) - (1/r_2)} \quad (3) <$$

Applying an energy balance to a control surface about the container at  $r = r_1$ ,

$$\dot{E}_{in} - \dot{E}_{out} = 0$$

$$\dot{q}\dot{V} - q_r = 0$$

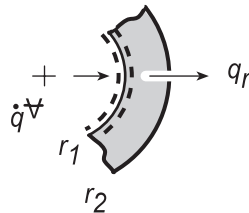

where  $\dot{q}\dot{V}$  represents the generated heat in the container,

$$q_r = (4/3)\pi r_1^3 \dot{q} \quad (4) <$$

(c) Applying an energy balance to a control surface placed around the outer surface of the insulation,

$$\dot{E}_{in} - \dot{E}_{out} = 0$$

$$q_r - q_{conv} - q_{rad} = 0$$

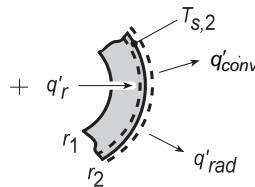

$$q_r - hA_s (T_{s,2} - T_{\infty}) - \varepsilon A_s \sigma (T_{s,2}^4 - T_{sur}^4) = 0 \quad (5) <$$

Continued...



## PROBLEM 2.52 (Cont.)

where

$$A_s = 4\pi r_2^2 \quad (6)$$

These relations can be used to determine  $T_{s,2}$  in terms of the variables  $\dot{q}$ ,  $r_1$ ,  $r_2$ ,  $h$ ,  $T_\infty$ ,  $\varepsilon$  and  $T_{sur}$ .

(d) Consider the reactor system operating under the following conditions:

$$\begin{aligned} r_1 &= 200 \text{ mm} & h &= 5 \text{ W/m}^2\cdot\text{K} & \varepsilon &= 0.9 \\ r_2 &= 208 \text{ mm} & T_\infty &= 25^\circ\text{C} & T_{sur} &= 35^\circ\text{C} \\ k &= 0.05 \text{ W/m}\cdot\text{K} \end{aligned}$$

The heat generated by the exothermic reaction provides for a volumetric heat generation rate,

$$\dot{q} = \dot{q}_0 \exp(-A/T_0) \quad \dot{q}_0 = 5000 \text{ W/m}^3 \quad A = 75 \text{ K} \quad (7)$$

where the temperature of the reaction is that of the inner surface of the insulation,  $T_o = T_{s,1}$ . The following system of equations will determine the operating conditions for the reactor.

*Conduction rate equation, insulation, Eq. (3),*

$$q_r = \frac{4\pi \times 0.05 \text{ W/m} \cdot \text{K} (T_{s,1} - T_{s,2})}{(1/0.200 \text{ m} - 1/0.208 \text{ m})} \quad (8)$$

*Heat generated in the reactor, Eqs. (4) and (7),*

$$q_r = 4/3 \pi (0.200 \text{ m})^3 \dot{q} \quad (9)$$

$$\dot{q} = 5000 \text{ W/m}^3 \exp(-75 \text{ K}/T_{s,1}) \quad (10)$$

*Surface energy balance, insulation, Eqs. (5) and (6),*

$$q_r - 5 \text{ W/m}^2 \cdot \text{K} A_s (T_{s,2} - 298 \text{ K}) - 0.9 A_s 5.67 \times 10^{-8} \text{ W/m}^2\cdot\text{K}^4 (T_{s,2}^4 - (308 \text{ K})^4) = 0 \quad (11)$$

$$A_s = 4\pi (0.208 \text{ m})^2 \quad (12)$$

Solving these equations simultaneously, find that

$$T_{s,1} = 94.3^\circ\text{C} \quad T_{s,2} = 52.5^\circ\text{C} \quad \leftarrow$$

That is, the reactor will be operating at  $T_o = T_{s,1} = 94.3^\circ\text{C}$ , very close to the desired  $95^\circ\text{C}$  operating condition.

(e) Using the above system of equations, Eqs. (8)-(12), we have explored the effects of changes in the convection coefficient,  $h$ , and the insulation thermal conductivity,  $k$ , as a function of insulation thickness,  $t = r_2 - r_1$ .

Continued...

### PROBLEM 2.52 (Cont.)

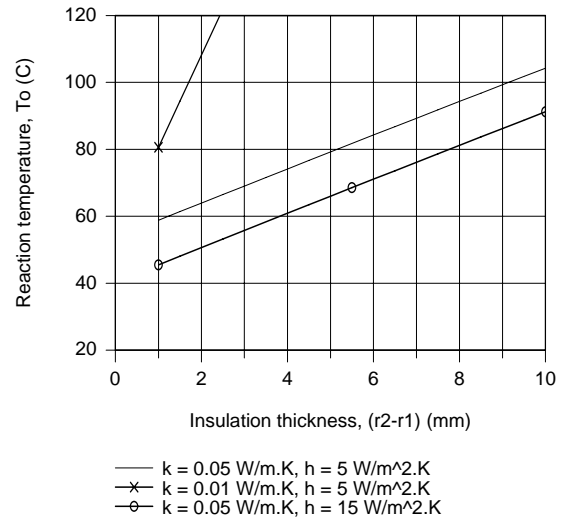
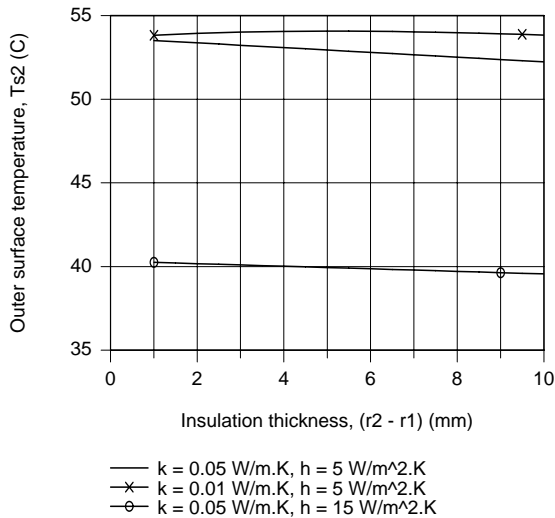

In the  $T_{s,2}$  vs.  $(r_2 - r_1)$  plot, note that decreasing the thermal conductivity from 0.05 to 0.01 W/m·K slightly increases  $T_{s,2}$  while increasing the convection coefficient from 5 to 15 W/m<sup>2</sup>·K markedly decreases  $T_{s,2}$ . Insulation thickness only has a minor effect on  $T_{s,2}$  for either option. In the  $T_o$  vs.  $(r_2 - r_1)$  plot, note that, for all the options, the effect of increased insulation is to increase the reaction temperature. With  $k = 0.01$  W/m·K, the reaction temperature increases beyond 95°C with less than 2 mm insulation. For the case with  $h = 15$  W/m<sup>2</sup>·K, the reaction temperature begins to approach 95°C with insulation thickness around 10 mm. We conclude that by selecting the proper insulation thickness and controlling the convection coefficient, the reaction could be operated around 95°C such that the outer surface temperature would not exceed 45°C.

## PROBLEM 2.53

**KNOWN:** Thin electrical heater dissipating  $4000 \text{ W/m}^2$  sandwiched between two 25-mm thick plates whose surfaces experience convection.

**FIND:** (a) On  $T$ - $x$  coordinates, sketch the steady-state temperature distribution for  $-L \leq x \leq +L$ ; calculate values for the surfaces  $x = L$  and the mid-point,  $x = 0$ ; label this distribution as Case 1 and explain key features; (b) Case 2: sudden loss of coolant causing existence of adiabatic condition on the  $x = +L$  surface; sketch temperature distribution on same  $T$ - $x$  coordinates as part (a) and calculate values for  $x = 0, \pm L$ ; explain key features; (c) Case 3: further loss of coolant and existence of adiabatic condition on the  $x = -L$  surface; situation goes undetected for 15 minutes at which time power to the heater is deactivated; determine the eventual ( $t \rightarrow \infty$ ) uniform, steady-state temperature distribution; sketch temperature distribution on same  $T$ - $x$  coordinates as parts (a,b); and (d) On  $T$ - $t$  coordinates, sketch the temperature-time history at the plate locations  $x = 0, \pm L$  during the transient period between the steady-state distributions for Case 2 and Case 3; at what location and when will the temperature in the system achieve a maximum value?

**SCHEMATIC:**

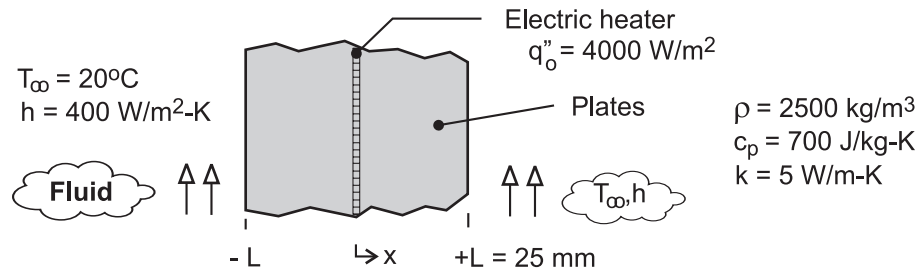

**ASSUMPTIONS:** (1) One-dimensional conduction, (2) Constant properties, (3) No internal volumetric generation in plates, and (3) Negligible thermal resistance between the heater surfaces and the plates.

**ANALYSIS:** (a) Since the system is symmetrical, the heater power results in equal conduction fluxes through the plates. By applying a surface energy balance on the surface  $x = +L$  as shown in the schematic, determine the temperatures at the mid-point,  $x = 0$ , and the exposed surface,  $x = +L$ .

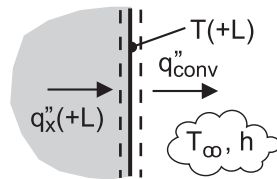

$$\dot{E}_{in} - \dot{E}_{out} = 0$$

$$q''_x(+L) - q''_{conv} = 0 \quad \text{where} \quad q''_x(+L) = q''_o / 2$$

$$q''_o / 2 - h [T(+L) - T_\infty] = 0$$

$$T_1(+L) = q''_o / 2h + T_\infty = 4000 \text{ W/m}^2 / (2 \times 400 \text{ W/m}^2 \cdot \text{K}) + 20^\circ\text{C} = 25^\circ\text{C} \quad <$$

From Fourier's law for the conduction flux through the plate, find  $T(0)$ .

$$q''_x = q''_o / 2 = k [T(0) - T(+L)] / L$$

$$T_1(0) = T_1(+L) + q''_o L / 2k = 25^\circ\text{C} + 4000 \text{ W/m}^2 \cdot \text{K} \times 0.025 \text{ m} / (2 \times 5 \text{ W/m} \cdot \text{K}) = 35^\circ\text{C} \quad <$$

The temperature distribution is shown on the  $T$ - $x$  coordinates below and labeled Case 1. The key features of the distribution are its symmetry about the heater plane and its linear dependence with distance.

Continued ...

### PROBLEM 2.53 (Cont.)

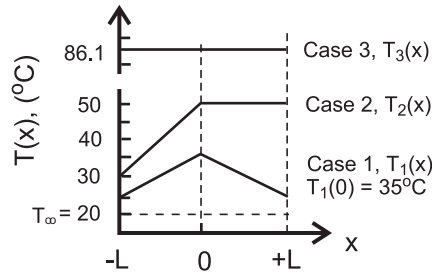

(b) Case 2: sudden loss of coolant with the existence of an adiabatic condition on surface  $x = +L$ . For this situation, all the heater power will be conducted to the coolant through the left-hand plate. From a surface energy balance and application of Fourier's law as done for part (a), find

$$T_2(-L) = q_0'' / h + T_\infty = 4000 \text{ W/m}^2 / 400 \text{ W/m}^2 \cdot \text{K} + 20^\circ\text{C} = 30^\circ\text{C} \quad <$$

$$T_2(0) = T_2(-L) + q_0'' L / k = 30^\circ\text{C} + 4000 \text{ W/m}^2 \times 0.025 \text{ m} / 5 \text{ W/m} \cdot \text{K} = 50^\circ\text{C} \quad <$$

The temperature distribution is shown on the  $T$ - $x$  coordinates above and labeled Case 2. The distribution is linear in the left-hand plate, with the maximum value at the mid-point. Since no heat flows through the right-hand plate, the gradient must be zero and this plate is at the maximum temperature as well. The maximum temperature is higher than for Case 1 because the heat flux through the left-hand plate has increased two-fold.

(c) Case 3: sudden loss of coolant occurs at the  $x = -L$  surface also. For this situation, there is no heat transfer out of either plate, so that for a 15-minute period,  $\Delta t_0$ , the heater dissipates  $4000 \text{ W/m}^2$  and then is deactivated. To determine the eventual, uniform steady-state temperature distribution, apply the conservation of energy requirement on a time-interval basis, Eq. 1.12b. The initial condition corresponds to the temperature distribution of Case 2, and the final condition will be a uniform, elevated temperature  $T_f = T_3$  representing Case 3. We have used  $T_\infty$  as the reference condition for the energy terms.

$$E_{\text{in}}'' - E_{\text{out}}'' + E_{\text{gen}}'' = \Delta E_{\text{st}}'' = E_f'' - E_i'' \quad (1)$$

Note that  $E_{\text{in}}'' - E_{\text{out}}'' = 0$ , and the dissipated electrical energy is

$$E_{\text{gen}}'' = q_0'' \Delta t_0 = 4000 \text{ W/m}^2 (15 \times 60) \text{ s} = 3.600 \times 10^6 \text{ J/m}^2 \quad (2)$$

For the final condition,

$$\begin{aligned} E_f'' &= \rho c (2L) [T_f - T_\infty] = 2500 \text{ kg/m}^3 \times 700 \text{ J/kg} \cdot \text{K} (2 \times 0.025 \text{ m}) [T_f - 20]^\circ\text{C} \\ E_f'' &= 8.75 \times 10^4 [T_f - 20] \text{ J/m}^2 \end{aligned} \quad (3)$$

where  $T_f = T_3$ , the final uniform temperature, Case 3. For the initial condition,

$$E_i'' = \rho c \int_{-L}^{+L} [T_2(x) - T_\infty] dx = \rho c \left\{ \int_{-L}^0 [T_2(x) - T_\infty] dx + \int_0^{+L} [T_2(0) - T_\infty] dx \right\} \quad (4)$$

where  $T_2(x)$  is linear for  $-L \leq x \leq 0$  and constant at  $T_2(0)$  for  $0 \leq x \leq +L$ .

$$T_2(x) = T_2(0) + [T_2(0) - T_2(L)] x / L \quad -L \leq x \leq 0$$

$$T_2(x) = 50^\circ\text{C} + [50 - 30]^\circ\text{C} x / 0.025 \text{ m}$$

$$T_2(x) = 50^\circ\text{C} + 800x \quad (5)$$

Substituting for  $T_2(x)$ , Eq. (5), into Eq. (4)

Continued ...

**PROBLEM 2.53 (Cont.)**

$$E_1'' = \rho c \left\{ \int_{-L}^0 [50 + 800x - T_\infty] dx + [T_2(0) - T_\infty] L \right\}$$

$$E_1'' = \rho c \left\{ \left[ 50x + 400x^2 - T_\infty x \right]_{-L}^0 + [T_2(0) - T_\infty] L \right\}$$

$$E_1'' = \rho c \left\{ -[-50L + 400L^2 + T_\infty L] + [T_2(0) - T_\infty] L \right\}$$

$$E_1'' = \rho c L \{ +50 - 400L - T_\infty + T_2(0) - T_\infty \}$$

$$E_1'' = 2500 \text{ kg/m}^3 \times 700 \text{ J/kg} \cdot \text{K} \times 0.025 \text{ m} \{ +50 - 400 \times 0.025 - 20 + 50 - 20 \} \text{ K}$$

$$E_1'' = 2.188 \times 10^6 \text{ J/m}^2 \quad (6)$$

Returning to the energy balance, Eq. (1), and substituting Eqs. (2), (3) and (6), find  $T_f = T_3$ .

$$3.600 \times 10^6 \text{ J/m}^2 = 8.75 \times 10^4 [T_3 - 20] - 2.188 \times 10^6 \text{ J/m}^2$$

$$T_3 = (66.1 + 20)^\circ\text{C} = 86.1^\circ\text{C} \quad <$$

The temperature distribution is shown on the T-x coordinates above and labeled Case 3. The distribution is uniform, and considerably higher than the maximum value for Case 2.

(d) The temperature-time history at the plate locations  $x = 0, \pm L$  during the transient period between the distributions for Case 2 and Case 3 are shown on the T-t coordinates below.

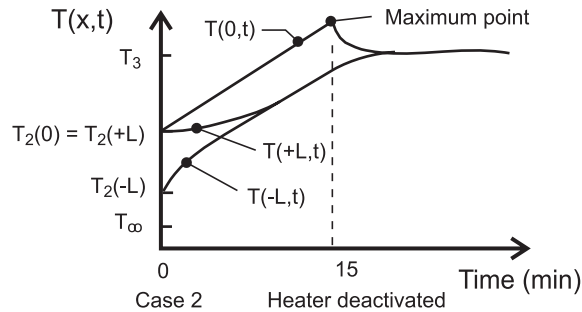

Note the temperatures for the locations at time  $t = 0$  corresponding to the instant when the surface  $x = -L$  becomes adiabatic. These temperatures correspond to the distribution for Case 2. The heater remains energized for yet another 15 minutes and then is deactivated. The midpoint temperature,  $T(0,t)$ , is always the hottest location and the maximum value slightly exceeds the final temperature  $T_3$ .

### PROBLEM 2.54

**KNOWN:** One-dimensional system, initially at a uniform temperature  $T_i$ , is suddenly exposed to a uniform heat flux at one boundary, while the other boundary is insulated.

**FIND:** (a) Proper form of heat equation and boundary and initial conditions, (b) Temperature distributions for following conditions: initial condition ( $t \leq 0$ ), and several times after heater is energized; will a steady-state condition be reached; (c) Heat flux at  $x = 0, L/2, L$  as a function of time; (d) Expression for uniform temperature,  $T_f$ , reached after heater has been switched off following an elapsed time,  $t_e$ , with the heater on.

**SCHEMATIC:**

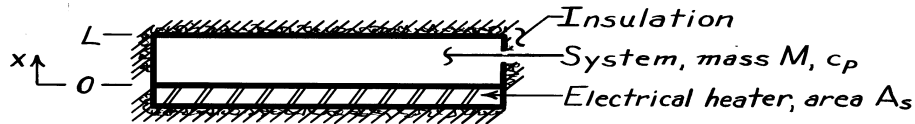

**ASSUMPTIONS:** (1) One-dimensional conduction, (2) No internal heat generation, (3) Constant properties.

**ANALYSIS:** (a) The appropriate form of the heat equation follows from Eq. 2.21. Also, the appropriate boundary and initial conditions are:

Initial condition:  $T(x,0) = T_i$  Uniform temperature

$$\frac{\partial^2 T}{\partial x^2} = \frac{1}{\alpha} \frac{\partial T}{\partial t}$$

Boundary conditions:  $x = 0 \quad q_0'' = -k \partial T / \partial x)_0$

$x = L \quad \partial T / \partial x)_L = 0$

(b) The temperature distributions are as follows:

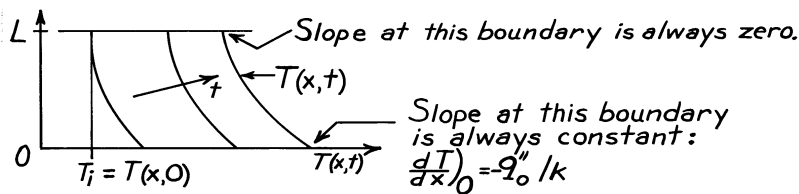

No steady-state condition will be reached since  $\dot{E}_{in} = \dot{E}_{st}$  and  $\dot{E}_{in}$  is constant.

(c) The heat flux as a function of time for positions  $x = 0, L/2$  and  $L$  is as follows:

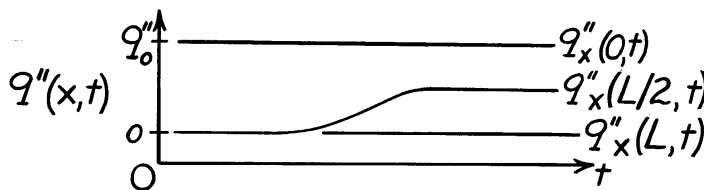

(d) If the heater is energized until  $t = t_e$  and then switched off, the system will eventually reach a uniform temperature,  $T_f$ . Perform an energy balance on the system, Eq. 1.12b, for an interval of time  $\Delta t = t_e$ ,

$$E_{in} = E_{st} \quad E_{in} = Q_{in} = \int_0^{t_e} q_0'' A_s dt = q_0'' A_s t_e \quad E_{st} = Mc(T_f - T_i)$$

It follows that  $q_0'' A_s t_e = Mc(T_f - T_i)$  or  $T_f = T_i + \frac{q_0'' A_s t_e}{Mc}$ .

## PROBLEM 2.55

**KNOWN:** Dimensions of one-dimensional plane wall, initial and boundary conditions.

**FIND:** (a) Differential equation, boundary and initial conditions used to determine  $T(x,t)$ , (b) Sketch of the temperature distributions for the initial condition, the steady-state condition, and for two intermediate times, (c) Sketch of the heat flux  $q_x''(x,t)$  at the planes  $x = 0, -L,$  and  $+L$ , (d) Sketch of the temperature distributions for the initial condition, the steady-state condition, and for two intermediate times for  $h_1$  twice the previous value, (e) Sketch of the heat flux  $q_x''(x,t)$  at the planes  $x = 0, -L,$  and  $+L$  for  $h_1$  twice the previous value.

**SCHEMATIC:**

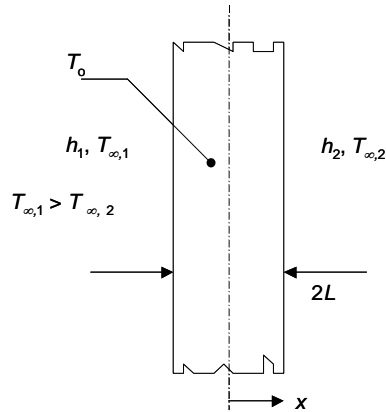

**ASSUMPTIONS:** (1) One-dimensional heat transfer, (2) Constant properties, (3) No internal generation.

**ANALYSIS:** The differential equation may be found by simplifying the heat equation, Equation 2.21. The simplification yields

$$\frac{\partial^2 T}{\partial x^2} = \frac{1}{\alpha} \frac{\partial T}{\partial t}$$

The initial and boundary conditions are:

$$T(x, t = 0) = T_o; \quad -k \left. \frac{\partial T}{\partial x} \right|_{x=-L} = h_1 [T_{\infty,1} - T(x = -L, t)]; \quad -k \left. \frac{\partial T}{\partial x} \right|_{x=+L} = h_2 [T(x = +L, t) - T_{\infty,2}]$$

(b) The temperature distributions are shown in the sketch below.

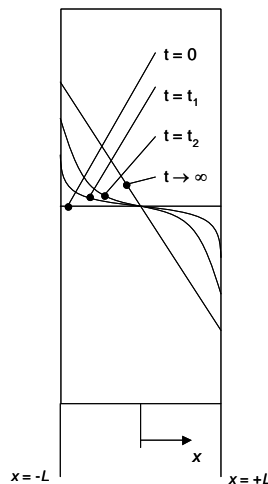

Continued...

### PROBLEM 2.55

The temperature is uniform at the initial time, as required by the initial condition listed in part (a). Note the temperature gradients at the exposed surfaces are large at early times and decrease in magnitude as the convective heat flux is reduced, as required by the boundary conditions listed in part (a). The steady-state temperature distribution is linear. At the steady state,

$$-k \frac{dT}{dx} = h_1 [T_{\infty,1} - T(x = -L)] = h_2 [T(x = +L) - T_{\infty,2}]$$

(c) At any time, the heat fluxes at  $x = \pm L$  are identical. The initial heat flux value is  $q_x''(x = \pm L) = h_1 [T_{\infty,1} - T_o] = h_2 [T_o - T_{\infty,2}]$ . As time progresses, thermal effects propagate to  $x = 0$ , resulting in a uniform heat flux distribution throughout the wall thickness.

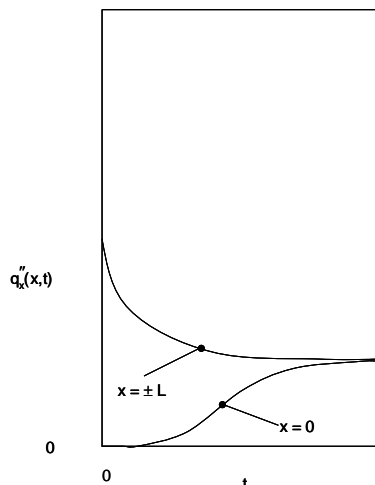

(d) A comparison of the transient response of the system for a doubled value of  $h_1$  is shown in the RHS sketch below. Note that for all but the initial time, temperatures throughout the wall are higher relative to the case associated with the original value of  $h_1$  (LHS). At intermediate times, temperature gradients at  $x = -L$  are larger than temperature gradients at  $x = +L$  due to the larger convection heat transfer coefficient at the left surface.

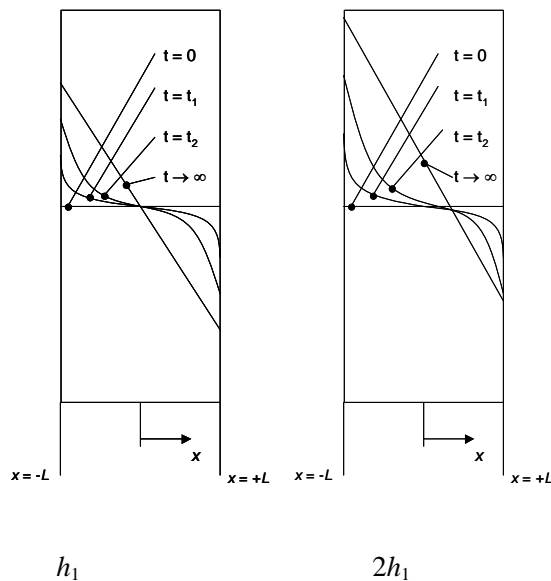

Continued...



### PROBLEM 2.55

(e) The heat flux histories are shown in the plot below as dashed lines. The results for part (c) are replicated as solid lines. Note that at the initial time, the heat flux at the left face is doubled relative to part (c) because the heat transfer coefficient is doubled. The heat flux at the initial time for the right face is the same as in part (c). The heat fluxes at the three planes asymptotically approach the steady-state value given by

$$-k \frac{dT}{dx} = 2h_1 [T_{\infty,1} - T(x = -L)] = h_2 [T(x = +L) - T_{\infty,2}]$$

Note that the overall heat flux is *not* doubled at the steady state since the temperature at the right face ( $T(x = \pm L)$ ) is greater for the case of the doubled LHS heat transfer coefficient,  $h_1$ .

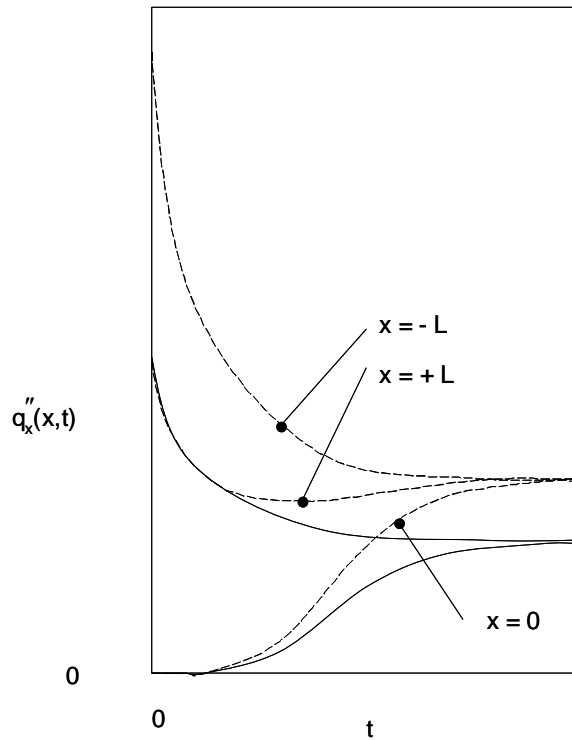

### PROBLEM 2.56

**KNOWN:** Plate of thickness  $2L$ , initially at a uniform temperature of  $T_i = 200^\circ\text{C}$ , is suddenly quenched in a liquid bath of  $T_\infty = 20^\circ\text{C}$  with a convection coefficient of  $100 \text{ W/m}^2\cdot\text{K}$ .

**FIND:** (a) On  $T$ - $x$  coordinates, sketch the temperature distributions for the initial condition ( $t \leq 0$ ), the steady-state condition ( $t \rightarrow \infty$ ), and two intermediate times; (b) On  $q_x'' - t$  coordinates, sketch the variation with time of the heat flux at  $x = L$ , (c) Determine the heat flux at  $x = L$  and for  $t = 0$ ; what is the temperature gradient for this condition; (d) By performing an energy balance on the plate, determine the amount of energy per unit surface area of the plate ( $\text{J/m}^2$ ) that is transferred to the bath over the time required to reach steady-state conditions; and (e) Determine the energy transferred to the bath during the quenching process using the exponential-decay relation for the surface heat flux.

**SCHEMATIC:**

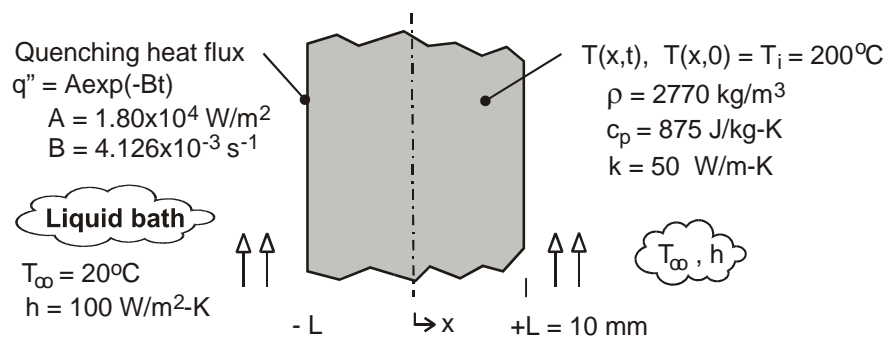

**ASSUMPTIONS:** (1) One-dimensional conduction, (2) Constant properties, and (3) No internal heat generation.

**ANALYSIS:** (a) The temperature distributions are shown in the sketch below.

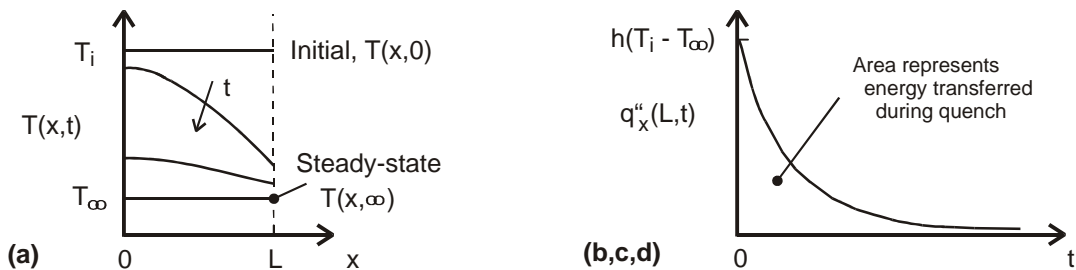

(b) The heat flux at the surface  $x = L$ ,  $q_x''(L, t)$ , is initially a maximum value, and decreases with increasing time as shown in the sketch above.

(c) The heat flux at the surface  $x = L$  at time  $t = 0$ ,  $q_x''(L, 0)$ , is equal to the convection heat flux with the surface temperature as  $T(L, 0) = T_i$ .

$$q_x''(L, 0) = q_{\text{conv}}''(t = 0) = h(T_i - T_\infty) = 100 \text{ W/m}^2 \cdot \text{K} (200 - 20)^\circ\text{C} = 18.0 \text{ kW/m}^2 <$$

From a surface energy balance as shown in the sketch considering the conduction and convection fluxes at the surface, the temperature gradient can be calculated.

Continued ...

**PROBLEM 2.56 (Cont.)**

$$\dot{E}_{\text{in}} - \dot{E}_{\text{out}} = 0$$

$$q''_x(L, 0) - q''_{\text{conv}}(t=0) = 0 \quad \text{with} \quad q''_x(L, 0) = -k \left. \frac{\partial T}{\partial x} \right|_{x=L}$$

$$\left. \frac{\partial T}{\partial x} \right|_{L,0} = -q''_{\text{conv}}(t=0) / k = -18 \times 10^3 \text{ W/m}^2 / 50 \text{ W/m} \cdot \text{K} = -360 \text{ K/m} \quad <$$

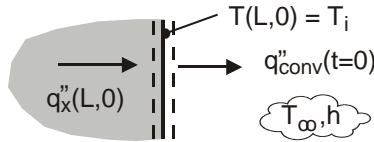

(d) The energy transferred from the plate to the bath over the time required to reach steady-state conditions can be determined from an energy balance on a time interval basis, Eq. 1.12b. For the initial state, the plate has a uniform temperature  $T_i$ ; for the final state, the plate is at the temperature of the bath,  $T_\infty$ .

$$E''_{\text{in}} - E''_{\text{out}} = \Delta E''_{\text{st}} = E''_f - E''_i \quad \text{with} \quad E''_{\text{in}} = 0,$$

$$-E''_{\text{out}} = \rho c_p (2L) [T_\infty - T_i]$$

$$E''_{\text{out}} = -2770 \text{ kg/m}^3 \times 875 \text{ J/kg} \cdot \text{K} (2 \times 0.010 \text{ m}) [20 - 200] \text{ K} = +8.73 \times 10^6 \text{ J/m}^2 \quad <$$

(e) The energy transfer from the plate to the bath during the quenching process can be evaluated from knowledge of the surface heat flux as a function of time. The area under the curve in the  $q''_x(L, t)$  vs. time plot (see schematic above) represents the energy transferred during the quench process.

$$E''_{\text{out}} = 2 \int_{t=0}^{\infty} q''_x(L, t) dt = 2 \int_{t=0}^{\infty} A e^{-Bt} dt$$

$$E''_{\text{out}} = 2A \left[ -\frac{1}{B} e^{-Bt} \right]_0^{\infty} = 2A \left[ -\frac{1}{B} (0 - 1) \right] = 2A / B$$

$$E''_{\text{out}} = 2 \times 1.80 \times 10^4 \text{ W/m}^2 / 4.126 \times 10^{-3} \text{ s}^{-1} = 8.73 \times 10^6 \text{ J/m}^2 \quad <$$

**COMMENTS:** (1) Can you identify and explain the important features in the temperature distributions of part (a)?

(2) The maximum heat flux from the plate occurs at the instant the quench process begins and is equal to the convection heat flux. At this instant, the gradient in the plate at the surface is a maximum. If the gradient is too large, excessive thermal stresses could be induced and cracking could occur.

(3) In this thermodynamic analysis, we were able to determine the energy transferred during the quenching process. We cannot determine the rate at which cooling of the plate occurs without solving the heat diffusion equation.

### PROBLEM 2.57

**KNOWN:** Plane wall, initially at a uniform temperature, is suddenly exposed to convective heating.

**FIND:** (a) Differential equation and initial and boundary conditions which may be used to find the temperature distribution,  $T(x,t)$ ; (b) Sketch  $T(x,t)$  for these conditions: initial ( $t \leq 0$ ), steady-state,  $t \rightarrow \infty$ , and two intermediate times; (c) Sketch heat fluxes as a function of time for surface locations; (d) Expression for total energy transferred to wall per unit volume ( $J/m^3$ ).

**SCHEMATIC:**

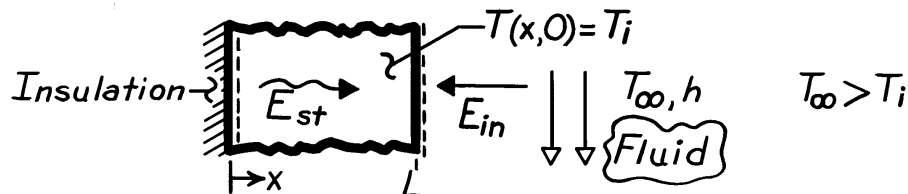

**ASSUMPTIONS:** (1) One-dimensional conduction, (2) Constant properties, (3) No internal heat generation.

**ANALYSIS:** (a) For one-dimensional conduction with constant properties, the heat equation has the form,

$$\frac{\partial^2 T}{\partial x^2} = \frac{1}{\alpha} \frac{\partial T}{\partial t}$$

and the conditions are:

Initial, $t \leq 0$ :	$T(x,0) = T_i$	uniform
Boundaries:	$x=0$ $\partial T / \partial x)_0 = 0$	adiabatic
	$x=L$ $-k \partial T / \partial x)_L = h [T(L,t) - T_\infty]$	convection

(b) The temperature distributions are shown on the sketch.

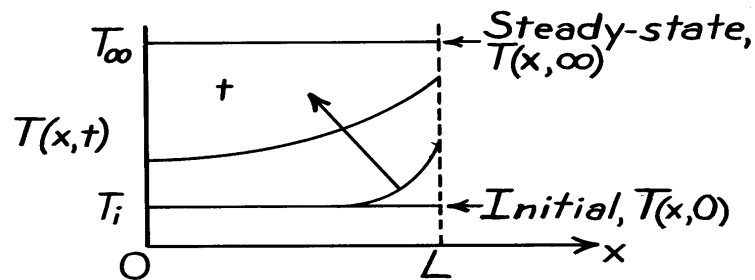

Note that the gradient at  $x = 0$  is always zero, since this boundary is adiabatic. Note also that the gradient at  $x = L$  decreases with time.

(c) The heat flux,  $q_x''(x,t)$ , as a function of time, is shown on the sketch for the surfaces  $x = 0$  and  $x = L$ .

Continued ...

**PROBLEM 2.57 (Cont.)**

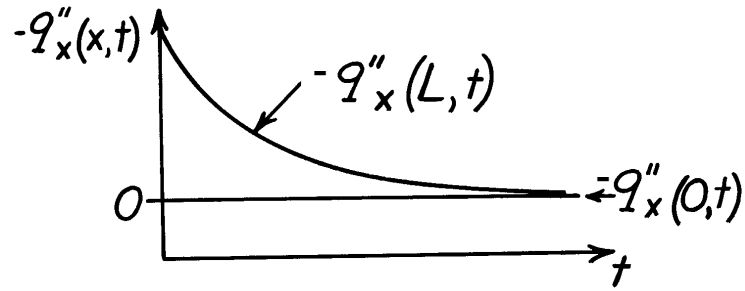

For the surface at  $x = 0$ ,  $q''_x(0, t) = 0$  since it is adiabatic. At  $x = L$  and  $t = 0$ ,  $q''_x(L, 0)$  is a maximum (in magnitude)

$$|q''_x(L, 0)| = h |T(L, 0) - T_\infty|$$

where  $T(L, 0) = T_i$ . The temperature difference, and hence the flux, decreases with time.

(d) The total energy transferred to the wall may be expressed as

$$E_{\text{in}} = \int_0^\infty q''_{\text{conv}} A_s dt$$

$$E_{\text{in}} = h A_s \int_0^\infty (T_\infty - T(L, t)) dt$$

Dividing both sides by  $A_s L$ , the energy transferred per unit volume is

$$\frac{E_{\text{in}}}{V} = \frac{h}{L} \int_0^\infty [T_\infty - T(L, t)] dt \quad \left[ \text{J/m}^3 \right]$$

**COMMENTS:** Note that the heat flux at  $x = L$  is into the wall and is hence in the negative  $x$  direction.

## PROBLEM 2.58

**KNOWN:** Qualitative temperature distributions in two cases.

**FIND:** For each of two cases, determine which material (A or B) has the higher thermal conductivity, how the thermal conductivity varies with temperature, description of the heat flux distribution through the composite wall, effect of simultaneously doubling the wall thickness and thermal conductivity.

**SCHEMATIC:**

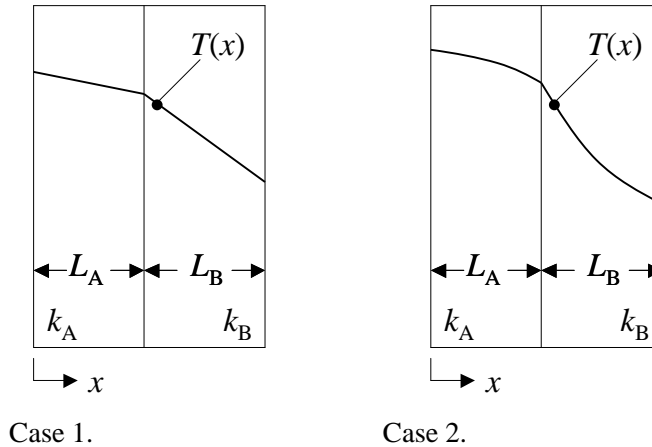

**ASSUMPTIONS:** (1) Steady-state, one-dimensional conditions, (2) Negligible contact resistances, (3) No internal energy generation.

**ANALYSIS:** Under steady-state conditions with no internal generation, the conservation of energy requirement dictates that the heat flux through the wall must be constant. <

For Materials A and B, Fourier's law is written  $q_A'' = -k_A \frac{dT_A}{dx} = q_B'' = -k_B \frac{dT_B}{dx}$ . Therefore,

$$\frac{k_A}{k_B} = \frac{dT_B/dx}{dT_A/dx} > 1 \quad \text{and} \quad k_B < k_A \quad \text{for both cases.} \quad <$$

Since the heat flux through the wall is constant, Fourier's law dictates that lower thermal conductivity material must exist where temperature gradients are larger. For Case 1, the temperature distributions are linear. Therefore, the temperature gradient is constant in each material, and the thermal conductivity of each material must not vary significantly with temperature. For Case 2, Material A, the temperature gradient is larger at lower temperatures. Hence, for Material A the thermal conductivity increases with increasing material temperature. For Case 2, Material B, the temperature gradient is smaller at lower temperatures. Hence, for Material B the thermal conductivity decreases with increases in material temperature. <

**COMMENTS:** If you were given information regarding the relative values of the thermal conductivities and how the thermal conductivities vary with temperature in each material, you should be able to sketch the temperature distributions provided in the problem statement.

### PROBLEM 2.59

**KNOWN:** Plane wall, initially at a uniform temperature  $T_i$ , is suddenly exposed to convection with a fluid at  $T_\infty$  at one surface, while the other surface is exposed to a constant heat flux  $q_0''$ .

**FIND:** (a) Temperature distributions,  $T(x,t)$ , for initial, steady-state and two intermediate times, (b) Corresponding heat fluxes on  $q_x'' - x$  coordinates, (c) Heat flux at locations  $x = 0$  and  $x = L$  as a function of time, (d) Expression for the steady-state temperature of the heater,  $T(0,\infty)$ , in terms of  $q_0''$ ,  $T_\infty$ ,  $k$ ,  $h$  and  $L$ .

**SCHEMATIC:**

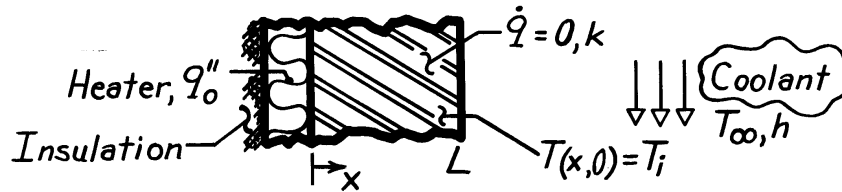

**ASSUMPTIONS:** (1) One-dimensional conduction, (2) No heat generation, (3) Constant properties.

**ANALYSIS:** (a) For  $T_i < T_\infty$ , the temperature distributions are

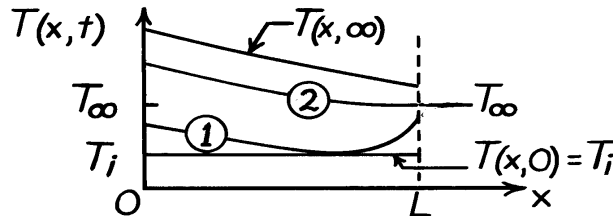

Note the constant gradient at  $x = 0$  since  $q_x''(0) = q_0''$ .

(b) The heat flux distribution,  $q_x''(x,t)$ , is determined from knowledge of the temperature gradients, evident from Part (a), and Fourier's law.

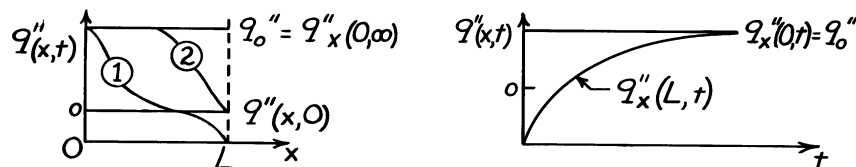

(c) On  $q_x''(x,t) - t$  coordinates, the heat fluxes at the boundaries are shown above.

(d) Perform a surface energy balance at  $x = L$  and an energy balance on the wall:

$$q_{\text{cond}}'' = q_{\text{conv}}'' = h [T(L,\infty) - T_\infty] \quad (1), \quad q_{\text{cond}}'' = q_0'' \quad (2)$$

For the wall, under steady-state conditions, Fourier's law gives

$$q_0'' = -k \frac{dT}{dx} = k \frac{T(0,\infty) - T(L,\infty)}{L} \quad (3)$$

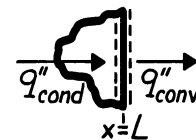

Combine Eqs. (1), (2), (3) to find:

$$T(0,\infty) = T_\infty + \frac{q_0''}{1/h + L/k}$$

## PROBLEM 2.60

**KNOWN:** Plane wall, initially at a uniform temperature  $T_0$ , has one surface ( $x = L$ ) suddenly exposed to a convection process ( $T_\infty > T_0, h$ ), while the other surface ( $x = 0$ ) is maintained at  $T_0$ . Also, wall experiences uniform volumetric heating  $\dot{q}$  such that the maximum steady-state temperature will exceed  $T_\infty$ .

**FIND:** (a) Sketch temperature distribution ( $T$  vs.  $x$ ) for following conditions: initial ( $t \leq 0$ ), steady-state ( $t \rightarrow \infty$ ), and two intermediate times; also show distribution when there is no heat flow at the  $x = L$  boundary, (b) Sketch the heat flux ( $q_x''$  vs.  $t$ ) at the boundaries  $x = 0$  and  $L$ .

**SCHEMATIC:**

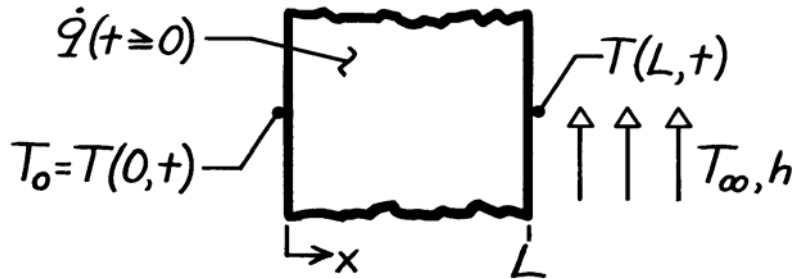

**ASSUMPTIONS:** (1) One-dimensional conduction, (2) Constant properties, (3) Uniform volumetric generation, (4)  $T_0 < T_\infty$  and  $\dot{q}$  large enough that  $T(x, \infty) > T_\infty$  for some  $x$ .

**ANALYSIS:** (a) The initial and boundary conditions for the wall can be written as

<i>Initial</i> ( $t \leq 0$ ):	$T(x, 0) = T_0$	Uniform temperature
<i>Boundary:</i>	$x = 0 \quad T(0, t) = T_0$	Constant temperature
	$x = L \quad -k \left. \frac{\partial T}{\partial x} \right _{x=L} = h [T(L, t) - T_\infty]$	Convection process.

The temperature distributions are shown on the  $T$ - $x$  coordinates below. Note the special condition when the heat flux at ( $x = L$ ) is zero.

(b) The heat flux as a function of time at the boundaries,  $q_x''(0, t)$  and  $q_x''(L, t)$ , can be inferred from the temperature distributions using Fourier's law.

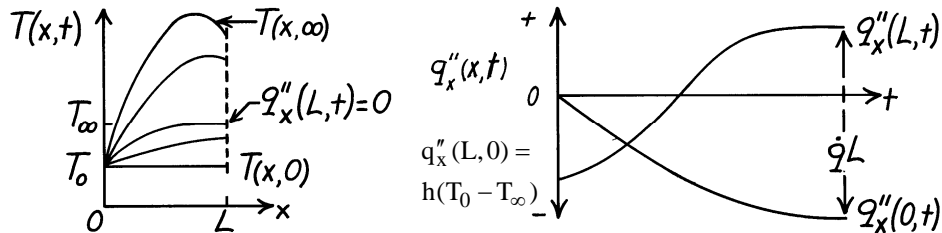

**COMMENTS:** Since  $T(x, \infty) > T_\infty$  for some  $x$  and  $T_\infty > T_0$ , heat transfer at both boundaries must be out of the wall at steady state. From an overall energy balance at steady state,  $+q_x''(L, \infty) - q_x''(0, \infty) = \dot{q}L$ .



## PROBLEM 2.61

**KNOWN:** Plane wall, initially at a uniform temperature  $T_o$ , has one surface ( $x = L$ ) suddenly exposed to a convection process ( $T_\infty < T_o$ ,  $h$ ), while the other surface ( $x = 0$ ) is maintained at  $T_o$ . Also, wall experiences uniform volumetric heating  $\dot{q}$  such that the maximum steady-state temperature will exceed  $T_\infty$ .

**FIND:** (a) Sketch temperature distribution ( $T$  vs.  $x$ ) for following conditions: initial ( $t \leq 0$ ), steady-state ( $t \rightarrow \infty$ ), and two intermediate times; identify key features of the distributions, (b) Sketch the heat flux ( $q''_x$  vs.  $t$ ) at the boundaries  $x = 0$  and  $L$ ; identify key features of the distributions.

**SCHEMATIC:**

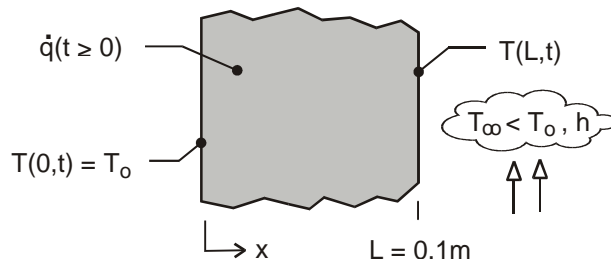

**ASSUMPTIONS:** (1) One-dimensional conduction, (2) Constant properties, (3) Uniform volumetric generation, (4)  $T_\infty < T_o$  and  $\dot{q}$  large enough that  $T(x, \infty) > T_o$ .

**ANALYSIS:** (a) The initial and boundary conditions for the wall can be written as

<i>Initial</i> ( $t \leq 0$ ):	$T(x, 0) = T_o$	Uniform temperature	
<i>Boundary:</i>	$x = 0$	$T(0, t) = T_o$	Constant temperature
	$x = L$	$-k \left. \frac{\partial T}{\partial x} \right _{x=L} = h [T(L, t) - T_\infty]$	Convection process.

The temperature distributions are shown on the  $T$ - $x$  coordinates below. Note that the maximum temperature occurs under steady-state conditions not at the midplane, but to the right toward the surface experiencing convection. The temperature gradients at  $x = L$  increase for  $t > 0$  since the convection heat rate from the surface increases as the surface temperature increases.

(b) The heat flux as a function of time at the boundaries,  $q''_x(0, t)$  and  $q''_x(L, t)$ , can be inferred from the temperature distributions using Fourier's law. At the surface  $x = L$ , the convection heat flux at  $t = 0$  is  $q''_x(L, 0) = h(T_o - T_\infty)$ . Because the surface temperature dips slightly at early times, the convection heat flux decreases slightly, and then increases until the steady-state condition is reached. For the steady-state condition, heat transfer at both boundaries must be out of the wall. It follows from an overall energy balance on the wall that  $+q''_x(0, \infty) - q''_x(L, \infty) + \dot{q}L = 0$ .

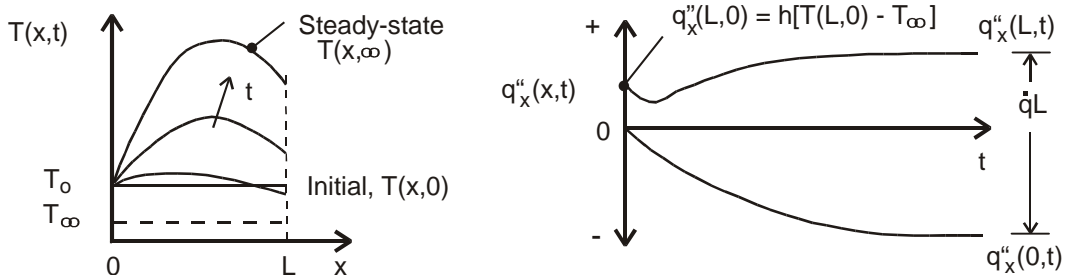

## PROBLEM 2.62

**KNOWN:** Qualitative temperature distribution in a composite wall with one material experiencing uniform volumetric energy generation.

**FIND:** Which material experiences uniform volumetric generation. The boundary condition at  $x = -L_A$ . Temperature distribution if the thermal conductivity of Material A is doubled. Temperature distribution if the thermal conductivity of Material B is doubled. Whether a contact resistance exists at the interface between the two materials. Sketch the heat flux distribution  $q_x''(x)$  through the composite wall.

**SCHEMATIC:**

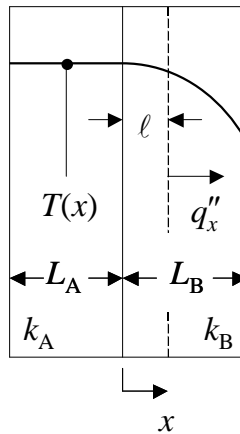

**ASSUMPTIONS:** (1) Steady-state, one-dimensional conditions, (2) Constant properties.

**ANALYSIS:** Consider a control volume with the LHS control surface at the interface between the two materials and the RHS control surface located at an arbitrary location within Material B, as shown in the schematic. For this control volume, conservation of energy and Fourier's law may be combined to yield, for uniform volumetric generation in Material B,

$$\dot{q}(\ell) = q_x'' = -k \left. \frac{dT}{dx} \right|_{x=\ell} \quad \text{or} \quad \left. \frac{dT}{dx} \right|_{x=\ell} \propto \ell \quad (1)$$

The temperature distribution of the problem reflects the preceding proportionality between the temperature gradient and the distance  $\ell$ , and it is appropriate to assume that uniform volumetric generation occurs in Material B but not in Material A. <

The boundary condition at  $x = -L_A$  is associated with perfectly insulated conditions,

$$0 = q_x''(x = -L_A) = -k \left. \frac{dT}{dx} \right|_{x=-L_A} \quad \text{or} \quad \left. \frac{dT}{dx} \right|_{x=-L_A} = 0 \quad <$$

The temperature distribution in Material A corresponds to  $q_{x,A}'' = 0$ , and is independent of its thermal conductivity. <

Continued...

### PROBLEM 2.62 (Cont.)

If the volumetric energy generation rate,  $\dot{q}$ , is unchanged, Equation (1) requires that the temperature gradient everywhere in Material B will be reduced by half if the thermal conductivity of Material B is doubled. Hence, the difference between the minimum and maximum temperatures in the composite wall would be reduced by half. <

Since there is no volumetric energy generation in Material A, and since the surface at  $x = -L_A$  is insulated, there can be no conduction of energy into or out of Material A at the LHS of the control volume previously described. Hence, if a contact resistance exists at the interface between Materials A and B, it would not induce any temperature drop across the interface since there is no heat transfer across the interface. Therefore, based on the temperature distribution given in the problem statement, it is impossible to conclude whether a contact resistance exists or not at the interface between Materials A and B. <

Considering Eq. 1, it follows that the heat flux distribution throughout the composite wall is as shown in the sketch below.

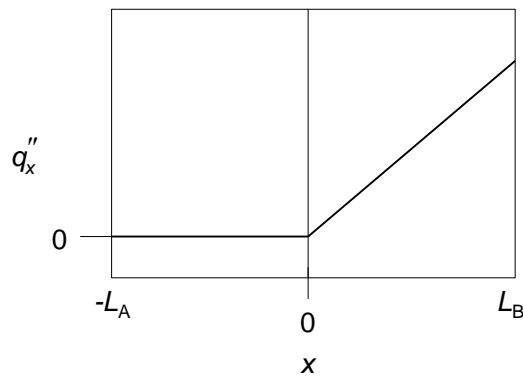

**COMMENTS:** If you were given information regarding which material experiences internal energy generation, the boundary condition at  $x = -L_A$ , the thermal conductivities of both materials, and the value of the contact resistance, you should be able to sketch the temperature and heat flux distributions. <

## PROBLEM 2.63

**KNOWN:** Size and thermal conductivities of a spherical particle encased by a spherical shell.

**FIND:** (a) Relationship between  $dT/dr$  and  $r$  for  $0 \leq r \leq r_1$ , (b) Relationship between  $dT/dr$  and  $r$  for  $r_1 \leq r \leq r_2$ , (c) Sketch of  $T(r)$  over the range  $0 \leq r \leq r_2$ .

**SCHEMATIC:**

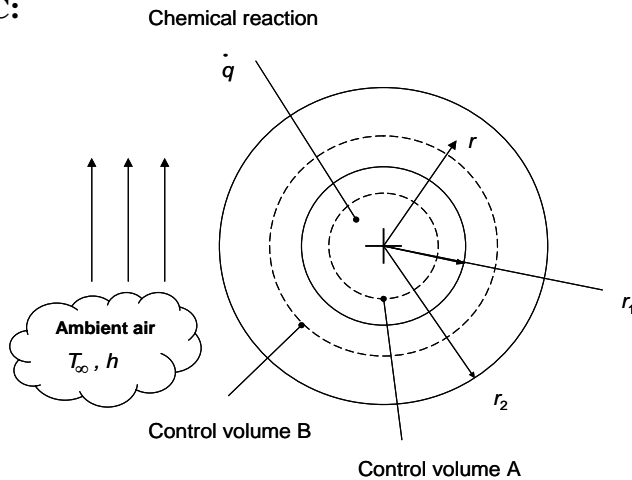

**ASSUMPTIONS:** (1) Steady-state conditions, (2) Constant properties, (3) One-dimensional heat transfer.

**ANALYSIS:**

(a) The conservation of energy principle, applied to control volume A, results in

$$\dot{E}_{\text{in}} + \dot{E}_g - \dot{E}_{\text{out}} = \dot{E}_{\text{st}} \quad (1)$$

where  $\dot{E}_g = \dot{q}\nabla = \dot{q}\frac{4}{3}\pi r^3$  (2)

since  $\dot{E}_{\text{st}} = 0$

$$\dot{E}_{\text{in}} - \dot{E}_{\text{out}} = q_r''A = -\left(-k_1 \frac{dT}{dr}\right)(4\pi r^2) \quad (3)$$

Substituting Eqs. (2) and (3) in Eq. (1) yields

$$\dot{q}\frac{4}{3}\pi r^3 + k_1 \frac{dT}{dr}(4\pi r^2) = 0$$

or

$$\frac{dT}{dr} = -\frac{\dot{q}}{3k_1} r \quad <$$

Continued...

### PROBLEM 2.63 (Cont.)

(b) For  $r > r_1$ , the radial heat rate is constant and is

$$\dot{E}_g = \dot{q}_r = \dot{q} \forall_1 = \dot{q} \frac{4}{3} \pi r_1^3 \quad (4)$$

$$\dot{E}_{in} - \dot{E}_{out} = \dot{q}_r'' A = - \left( k_2 \frac{dT}{dr} \right) 4\pi r^2 \quad (5)$$

Substituting Eqs. (4) and (5) into Eq. (1) yields

$$k_2 \frac{dT}{dr} 4\pi r^2 + \dot{q} \frac{4}{3} \pi r_1^3 = 0$$

or

$$\frac{dT}{dr} = - \frac{\dot{q} r_1^3}{3k_2 r^2} \quad <$$

(c) The temperature distribution on T-r coordinates is

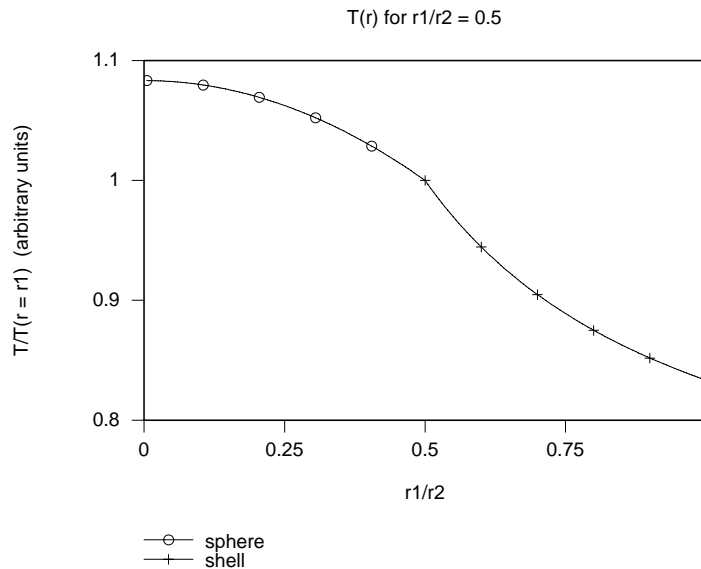

**COMMENTS:** (1) Note the non-linear temperature distributions in both the particle and the shell. (2) The temperature gradient at  $r = 0$  is zero. (3) The discontinuous slope of  $T(r)$  at  $r_1/r_2 = 0.5$  is a result of  $k_1 = 2k_2$ .

### PROBLEM 2.64

**KNOWN:** Long cylindrical rod with uniform initial temperature immersed in liquid at a lower temperature.

**FIND:** Sketch temperature distribution at initial time, steady state, and two intermediate times for two rods with different thermal conductivities. State boundary conditions at centerline and surface.

**SCHEMATIC:**

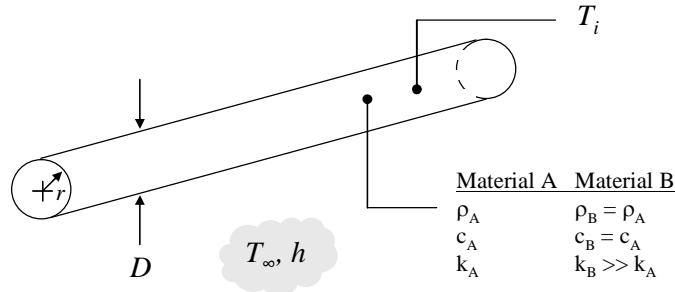

**ASSUMPTIONS:** (1) One-dimensional conduction in radial direction, (2) Constant properties, (3) Fluid temperature remains constant, (4) Convection heat transfer coefficient is constant.

**ANALYSIS:** Referring to the figure below, first consider Material A of moderate thermal conductivity. Initially, the rod temperature is uniform at  $T_i$ . When the rod is first exposed to the liquid, heat is transferred from the rod to the fluid due to convection, causing the surface temperature to decrease. The resulting temperature gradient in the rod causes heat to conduct radially outward, and the temperature further inside the rod decreases as well. Toward the beginning of this process, the temperature near the center of the rod is still very close to the initial temperature (see Material A,  $t_1$ ). As time increases, the temperature everywhere in the rod decreases (see Material A,  $t_2$ ). Eventually, at steady state, the rod temperature reaches the fluid temperature,  $T_\infty$ .

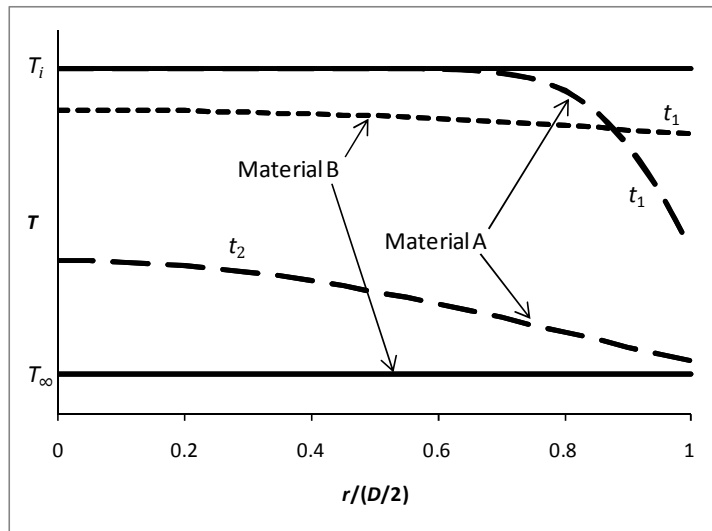

<

Continued...

### PROBLEM 2.64 (Cont.)

The boundary condition at the rod surface expresses a balance between heat reaching the surface by conduction and heat leaving the surface by convection:

$$-k \left. \frac{\partial T}{\partial r} \right|_{D/2} = h [T(D/2, t) - T_\infty] \quad (1) \quad <$$

From this, it can be seen that the temperature gradient at the surface is negative and its magnitude decreases with time as the surface temperature approaches the fluid temperature. This is shown for the two intermediate times for Material A.

Next compare Material A to Material B having a very large thermal conductivity. At time  $t = 0$  when both rods have the same temperature  $T_i$ , it can be seen from the right hand side of Equation (1) that the heat flux is the same for both materials. Energy is being removed from both rods at the same rate. However, because of the large thermal conductivity of material B, its temperature gradient is smaller and its temperature tends to be nearly uniform, as shown in the figure for Material B,  $t_1$ . Its temperature is higher at the surface and lower in the center as compared to Material A. Because its surface temperature stays higher for longer, the heat flux leaving the rod is larger, and overall it cools faster. At time  $t_2$ , when Material A's surface temperature is close to  $T_\infty$ , but it is still warm in the center, Material B has already reached steady state.

The rod with the higher thermal conductivity reaches steady state sooner. <

The boundary condition at  $r = 0$  expresses radial symmetry:

$$\left. \frac{\partial T}{\partial r} \right|_0 = 0 \quad <$$

The boundary condition at  $r = D/2$  was given in Equation (1).

**COMMENTS:** The problem of transient conduction in a cylinder will be solved in Chapter 5.

### PROBLEM 2.65

**KNOWN:** Temperature distribution in a plane wall of thickness  $L$  experiencing uniform volumetric heating  $\dot{q}$  having one surface ( $x = 0$ ) insulated and the other exposed to a convection process characterized by  $T_\infty$  and  $h$ . Suddenly the volumetric heat generation is deactivated while convection continues to occur.

**FIND:** (a) Determine the magnitude of the volumetric energy generation rate associated with the initial condition, (b) On  $T$ - $x$  coordinates, sketch the temperature distributions for the initial condition ( $T \leq 0$ ), the steady-state condition ( $t \rightarrow \infty$ ), and two intermediate times; (c) On  $q_x''$  -  $t$  coordinates, sketch the variation with time of the heat flux at the boundary exposed to the convection process,  $q_x''(L, t)$ ; calculate the corresponding value of the heat flux at  $t = 0$ ; and (d) Determine the amount of energy removed from the wall per unit area ( $J/m^2$ ) by the fluid stream as the wall cools from its initial to steady-state condition.

**SCHEMATIC:**

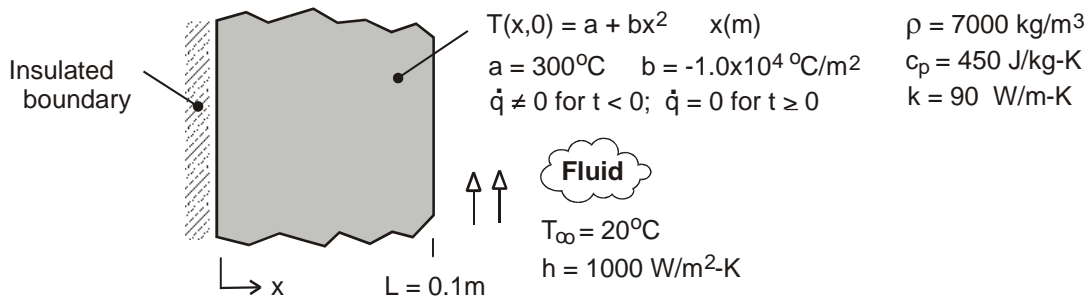

**ASSUMPTIONS:** (1) One-dimensional conduction, (2) Constant properties, and (3) Uniform internal volumetric heat generation for  $t < 0$ .

**ANALYSIS:** (a) The volumetric heating rate can be determined by substituting the temperature distribution for the initial condition into the appropriate form of the heat diffusion equation.

$$\frac{d}{dx} \left( \frac{dT}{dx} \right) + \frac{\dot{q}}{k} = 0 \quad \text{where} \quad T(x, 0) = a + bx^2$$

$$\frac{d}{dx} (0 + 2bx) + \frac{\dot{q}}{k} = 0 = 2b + \frac{\dot{q}}{k} = 0$$

$$\dot{q} = -2kb = -2 \times 90 \text{ W}/\text{m} \cdot \text{K} \left( -1.0 \times 10^4 \text{ }^\circ\text{C}/\text{m}^2 \right) = 1.8 \times 10^6 \text{ W}/\text{m}^3 \quad <$$

(b) The temperature distributions are shown in the sketch below.

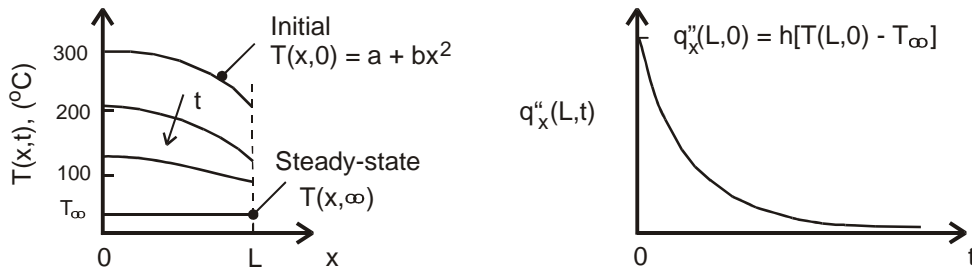

Continued ...



**PROBLEM 2.65 (Cont.)**

(c) The heat flux at the exposed surface  $x = L$ ,  $q_x''(L, 0)$ , is initially a maximum value and decreases with increasing time as shown in the sketch above. The heat flux at  $t = 0$  is equal to the convection heat flux with the surface temperature  $T(L, 0)$ . See the surface energy balance represented in the schematic.

$$q_x''(L, 0) = q_{\text{conv}}''(t=0) = h(T(L, 0) - T_\infty) = 1000 \text{ W/m}^2 \cdot \text{K} (200 - 20)^\circ\text{C} = 1.80 \times 10^5 \text{ W/m}^2 <$$

$$\text{where } T(L, 0) = a + bL^2 = 300^\circ\text{C} - 1.0 \times 10^4 \text{ }^\circ\text{C/m}^2 (0.1\text{m})^2 = 200^\circ\text{C}.$$

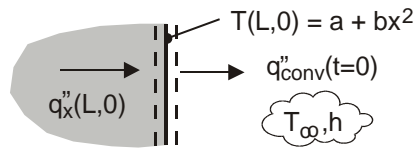

(d) The energy removed from the wall to the fluid as it cools from its initial to steady-state condition can be determined from an energy balance on a time interval basis, Eq. 1.12b. For the initial state, the wall has the temperature distribution  $T(x, 0) = a + bx^2$ ; for the final state, the wall is at the temperature of the fluid,  $T_f = T_\infty$ . We have used  $T_\infty$  as the reference condition for the energy terms.

$$E_{\text{in}}'' - E_{\text{out}}'' = \Delta E_{\text{st}}'' = E_f'' - E_i'' \quad \text{with} \quad E_{\text{in}}'' = 0$$

$$E_{\text{out}}'' = \rho c_p \int_{x=0}^{x=L} [T(x, 0) - T_\infty] dx$$

$$E_{\text{out}}'' = \rho c_p \int_{x=0}^{x=L} [a + bx^2 - T_\infty] dx = \rho c_p \left[ ax + bx^3/3 - T_\infty x \right]_0^L$$

$$E_{\text{out}}'' = 7000 \text{ kg/m}^3 \times 450 \text{ J/kg} \cdot \text{K} \left[ 300 \times 0.1 - 1.0 \times 10^4 (0.1)^3 / 3 - 20 \times 0.1 \right] \text{ K} \cdot \text{m}$$

$$E_{\text{out}}'' = 7.77 \times 10^7 \text{ J/m}^2 <$$

**COMMENTS:** (1) In the temperature distributions of part (a), note these features: initial condition has quadratic form with zero gradient at the adiabatic boundary; for the steady-state condition, the wall has reached the temperature of the fluid; for all distributions, the gradient at the adiabatic boundary is zero; and, the gradient at the exposed boundary decreases with increasing time.

(2) In this thermodynamic analysis, we were able to determine the energy transferred during the cooling process. However, we cannot determine the rate at which cooling of the wall occurs without solving the heat diffusion equation.

## PROBLEM 2.66

**KNOWN:** Temperature as a function of position and time in a plane wall suddenly subjected to a change in surface temperature, while the other surface is insulated.

**FIND:** (a) Validate the temperature distribution, (b) Heat fluxes at  $x = 0$  and  $x = L$ , (c) Sketch of temperature distribution at selected times and surface heat flux variation with time, (d) Effect of thermal diffusivity on system response.

**SCHEMATIC:**

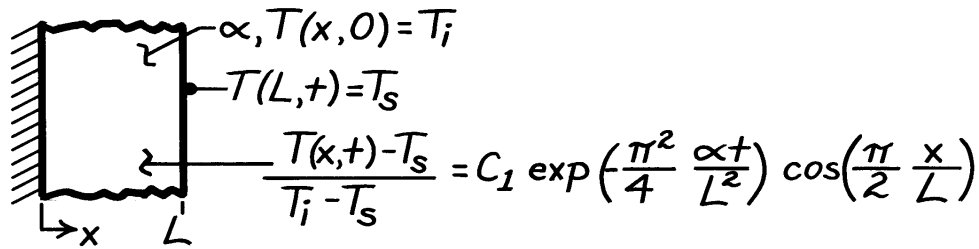

**ASSUMPTIONS:** (1) One-dimensional conduction in  $x$ , (2) Constant properties.

**ANALYSIS:** (a) To be valid, the temperature distribution must satisfy the appropriate forms of the heat equation and boundary conditions. Substituting the distribution into Equation 2.21, it follows that

$$\begin{aligned} \frac{\partial^2 T}{\partial x^2} &= \frac{1}{\alpha} \frac{\partial T}{\partial t} \\ -C_1 (T_i - T_s) \exp\left(-\frac{\pi^2}{4} \frac{\alpha t}{L^2}\right) \left(\frac{\pi}{2L}\right)^2 \cos\left(\frac{\pi x}{2L}\right) \\ &= -\frac{C_1}{\alpha} (T_i - T_s) \left(\frac{\pi^2}{4} \frac{\alpha}{L^2}\right) \exp\left(-\frac{\pi^2}{4} \frac{\alpha t}{L^2}\right) \cos\left(\frac{\pi x}{2L}\right). \end{aligned} \quad <$$

Hence, the heat equation is satisfied. Applying boundary conditions at  $x = 0$  and  $x = L$ , it follows that

$$\frac{\partial T}{\partial x} \Big|_{x=0} = -\frac{C_1 \pi}{2L} (T_i - T_s) \exp\left(-\frac{\pi^2}{4} \frac{\alpha t}{L^2}\right) \sin\left(\frac{\pi x}{2L}\right) \Big|_{x=0} = 0 \quad <$$

and

$$T(L, t) = T_s + C_1 (T_i - T_s) \exp\left(-\frac{\pi^2}{4} \frac{\alpha t}{L^2}\right) \cos\left(\frac{\pi x}{2L}\right) \Big|_{x=L} = T_s. \quad <$$

Hence, the boundary conditions are also satisfied.

(b) The heat flux has the form

$$q_x'' = -k \frac{\partial T}{\partial x} = +\frac{k C_1 \pi}{2L} (T_i - T_s) \exp\left(-\frac{\pi^2}{4} \frac{\alpha t}{L^2}\right) \sin\left(\frac{\pi x}{2L}\right).$$

Continued ...

**PROBLEM 2.66 (Cont.)**

Hence,  $q''_x(0) = 0,$

<

$$q''_x(L) = + \frac{kC_1\pi}{2L} (T_i - T_s) \exp\left(-\frac{\pi^2}{4} \frac{\alpha t}{L^2}\right).$$

<

(c) The temperature distribution and surface heat flux variations are:

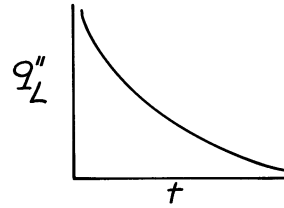
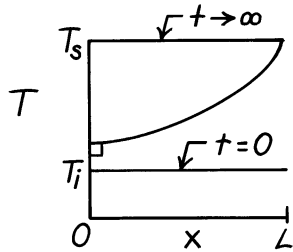

(d) For materials A and B of different  $\alpha$ ,

$$\frac{[T(x,t) - T_s]_A}{[T(x,t) - T_s]_B} = \exp\left[-\frac{\pi^2}{4L^2}(\alpha_A - \alpha_B)t\right]$$

Hence, if  $\alpha_A > \alpha_B$ ,  $T(x,t) \rightarrow T_s$  more rapidly for Material A. If  $\alpha_A < \alpha_B$ ,  $T(x,t) \rightarrow T_s$  more rapidly for Material B.

<

**COMMENTS:** Note that the prescribed function for  $T(x,t)$  does not reduce to  $T_i$  for  $t \rightarrow 0$ . For times at or close to zero, the function is not a valid solution of the problem. At such times, the solution for  $T(x,t)$  must include additional terms. The solution is considered in Section 5.5.1 of the text.

### PROBLEM 2.67

**KNOWN:** Thickness of composite plane wall consisting of material A in left half and material B in right half. Exothermic reaction in material A and endothermic reaction in material B, with equal and opposite heat generation rates. External surfaces are insulated.

**FIND:** Sketch temperature and heat flux distributions for three thermal conductivity ratios,  $k_A/k_B$ .

**SCHEMATIC:**

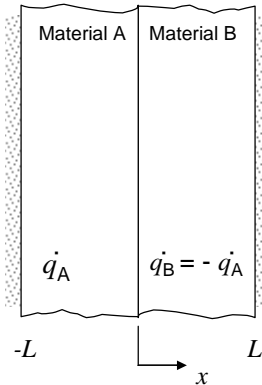

**ASSUMPTIONS:** (1) Steady-state conditions, (2) One-dimensional conduction, (3) Constant properties.

**ANALYSIS:** From Equation 2.19 for steady-state, one-dimensional conduction, we find

$$\frac{\partial}{\partial x} \left( k \frac{\partial T}{\partial x} \right) = -\dot{q} \quad \text{or} \quad \frac{\partial q_x''}{\partial x} = \dot{q}$$

From the second equation, with uniform heat generation rate, we see that  $q_x''$  varies linearly with  $x$ , and its slope is  $+\dot{q}_A$  in material A and  $-\dot{q}_A$  in material B. Furthermore, since the wall is insulated on both exterior surfaces, the heat flux must be zero at  $x = \pm L$ . Thus, the heat flux is as shown in the graph below and does not depend on the thermal conductivities. The heat generated in the left half is conducting to the right and accumulating as it goes. Once it reaches the centerline, it begins to be consumed by the exothermic reaction and drops to zero at  $x = L$ .

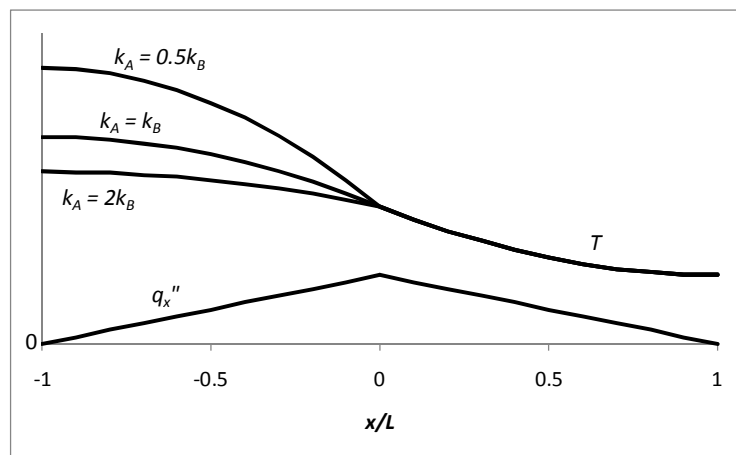

Continued...

### PROBLEM 2.67 (Cont.)

Since  $q_x'' = -k \frac{\partial T}{\partial x}$ , the temperature gradient is negative everywhere, and its magnitude is greatest where the heat flux is greatest. Thus the slope of the temperature distribution is zero at  $x = -L$ , it becomes more negative as it reaches the center, and then becomes flatter again until it reaches a slope of zero at  $x = L$ . When  $k_A = k_B$ , the temperature distribution has equal and opposite slopes on either side of the centerline. If  $k_B$  is held fixed and  $k_A$  is varied, the results are as shown in the plot above. Since the temperature gradient is inversely proportional to the thermal conductivity, it is steeper in the region that has the smaller thermal conductivity. Physically, when thermal conductivity is larger, heat conducts more readily and causes the temperature to become more uniform.

If  $\dot{q}_B = -2\dot{q}_A$ , an energy balance on the wall gives:

$$\begin{aligned}\frac{dE_{st}}{dt} &= \dot{E}_{in} - \dot{E}_{out} + \dot{E}_g \\ \frac{dE_{st}}{dt} &= \dot{E}_g = (\dot{q}_A + \dot{q}_B)V = -\dot{q}_A V\end{aligned}$$

where  $V$  is the volume. Since  $dE_{st}/dt$  is non-zero, the wall cannot be at steady-state. With the exothermic reaction greater than the endothermic reaction, the wall will continuously decrease in temperature. <

**COMMENTS:** (1) Given the information in the problem statement, it is not possible to calculate actual temperatures. There are an infinite number of correct solutions regarding temperature *values*, but only one correct solution regarding the *shape* of the temperature distribution. (2) Chemical reactions would cease if the temperature became too small. It would not be possible to continually cool the wall for the case when, initially,  $\dot{q}_B = -2\dot{q}_A$ .

## PROBLEM 2.68

**KNOWN:** Radius and length of coiled wire in hair dryer. Electric power dissipation in the wire, and temperature and convection coefficient associated with air flow over the wire.

**FIND:** (a) Form of heat equation and conditions governing transient, thermal behavior of wire during start-up, (b) Volumetric rate of thermal energy generation in the wire, (c) Sketch of temperature distribution at selected times during start-up, (d) Variation with time of heat flux at  $r = 0$  and  $r = r_o$ .

**SCHEMATIC:**

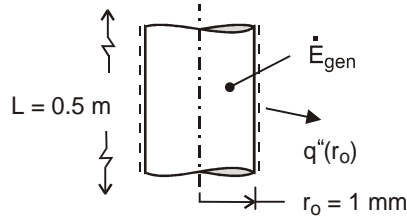

**ASSUMPTIONS:** (1) One-dimensional, radial conduction, (2) Constant properties, (3) Uniform volumetric heating, (4) Negligible radiation from surface of wire.

**ANALYSIS:** (a) The general form of the heat equation for cylindrical coordinates is given by Eq. 2.26. For one-dimensional, radial conduction and constant properties, the equation reduces to

$$\frac{1}{r} \frac{\partial}{\partial r} \left( r \frac{\partial T}{\partial r} \right) + \frac{\dot{q}}{k} = \frac{\rho c_p}{k} \frac{\partial T}{\partial t} = \frac{1}{\alpha} \frac{\partial T}{\partial t} \quad <$$

The initial condition is  $T(r, 0) = T_i$  <

The boundary conditions are:  $\partial T / \partial r|_{r=0} = 0$  <

$$-k \frac{\partial T}{\partial r} \Big|_{r=r_o} = h [T(r_o, t) - T_\infty] \quad <$$

(b) The volumetric rate of thermal energy generation is

$$\dot{q} = \frac{\dot{E}_g}{V} = \frac{P_{\text{elec}}}{\pi r_o^2 L} = \frac{500 \text{ W}}{\pi (0.001 \text{ m})^2 (0.5 \text{ m})} = 3.18 \times 10^8 \text{ W/m}^3 \quad <$$

Under steady-state conditions, all of the thermal energy generated within the wire is transferred to the air by convection. Performing an energy balance for a control surface about the wire,  $-\dot{E}_{\text{out}} + \dot{E}_g = 0$ , it follows that  $-2\pi r_o L q''(r_o, t \rightarrow \infty) + P_{\text{elec}} = 0$ . Hence,

$$q''(r_o, t \rightarrow \infty) = \frac{P_{\text{elec}}}{2\pi r_o L} = \frac{500 \text{ W}}{2\pi (0.001 \text{ m}) 0.5 \text{ m}} = 1.59 \times 10^5 \text{ W/m}^2 \quad <$$

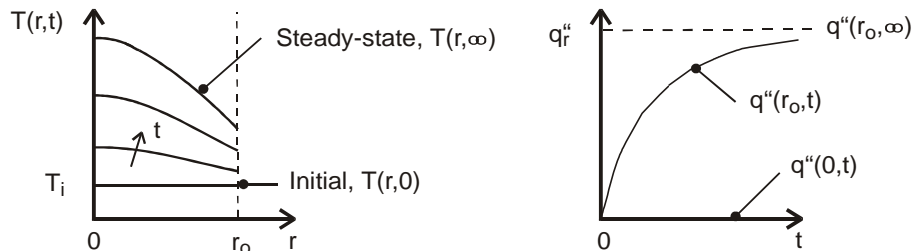

**COMMENTS:** The symmetry condition at  $r = 0$  imposes the requirement that  $\partial T / \partial r|_{r=0} = 0$ , and hence  $q''(0, t) = 0$  throughout the process. The temperature at  $r_o$ , and hence the convection heat flux, increases steadily during the start-up, and since conduction to the surface must be balanced by convection from the surface at all times,  $|\partial T / \partial r|_{r=r_o}$  also increases during the start-up.

### PROBLEM 2.69

**KNOWN:** Temperature distribution in a composite wall.

**FIND:** (a) Relative magnitudes of interfacial heat fluxes, (b) Relative magnitudes of thermal conductivities, and (c) Heat flux as a function of distance  $x$ .

**SCHEMATIC:**

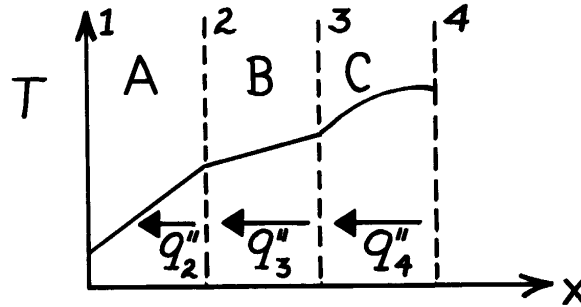

**ASSUMPTIONS:** (1) Steady-state conditions, (2) One-dimensional conduction, (3) Constant properties.

**ANALYSIS:** (a) For the prescribed conditions (one-dimensional, steady-state, constant  $k$ ), the parabolic temperature distribution in C implies the existence of heat generation. Hence, since  $dT/dx$  increases with decreasing  $x$ , the heat flux in C increases with decreasing  $x$ . Hence,

$$q''_3 > q''_4$$

However, the linear temperature distributions in A and B indicate no generation, in which case

$$q''_2 = q''_3$$

(b) Since conservation of energy requires that  $q''_{3,B} = q''_{3,C}$  and  $dT/dx)_B < dT/dx)_C$ , it follows from Fourier's law that

$$k_B > k_C.$$

Similarly, since  $q''_{2,A} = q''_{2,B}$  and  $dT/dx)_A > dT/dx)_B$ , it follows that

$$k_A < k_B.$$

(c) It follows that the flux distribution appears as shown below.

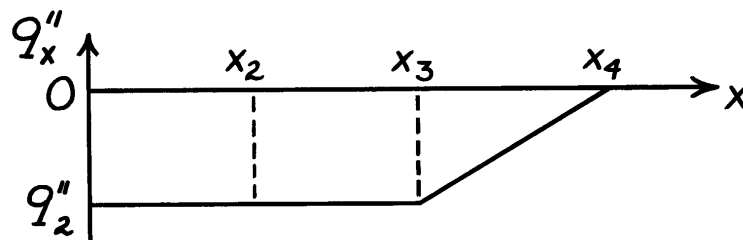

**COMMENTS:** Note that, with  $dT/dx)_{4,C} = 0$ , the interface at 4 is adiabatic.

### PROBLEM 3.1

**KNOWN:** One-dimensional, plane wall separating hot and cold fluids at  $T_{\infty,1}$  and  $T_{\infty,2}$ , respectively.

**FIND:** Temperature distribution,  $T(x)$ , and heat flux,  $q''_x$ , in terms of  $T_{\infty,1}$ ,  $T_{\infty,2}$ ,  $h_1$ ,  $h_2$ ,  $k$  and  $L$ .

**SCHEMATIC:**

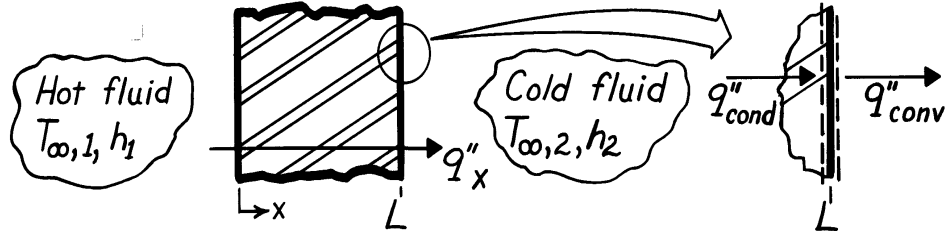

**ASSUMPTIONS:** (1) One-dimensional conduction, (2) Steady-state conditions, (3) Constant properties, (4) Negligible radiation, (5) No generation.

**ANALYSIS:** For the foregoing conditions, the general solution to the heat diffusion equation is of the form, Equation 3.2,

$$T(x) = C_1x + C_2. \quad (1)$$

The constants of integration,  $C_1$  and  $C_2$ , are determined by using surface energy balance conditions at  $x = 0$  and  $x = L$ , Equation 2.34, and as illustrated above,

$$-k \left. \frac{dT}{dx} \right|_{x=0} = h_1 [T_{\infty,1} - T(0)] \quad -k \left. \frac{dT}{dx} \right|_{x=L} = h_2 [T(L) - T_{\infty,2}]. \quad (2,3)$$

For the boundary condition at  $x = 0$ , Equation (2), use Equation (1) to find

$$-k(C_1 + 0) = h_1 [T_{\infty,1} - (C_1 \cdot 0 + C_2)] \quad (4)$$

and for the boundary condition at  $x = L$  to find

$$-k(C_1 + 0) = h_2 [(C_1L + C_2) - T_{\infty,2}]. \quad (5)$$

Multiply Eq. (4) by  $h_2$  and Eq. (5) by  $h_1$ , and add the equations to obtain  $C_1$ . Then substitute  $C_1$  into Eq. (4) to obtain  $C_2$ . The results are

$$C_1 = -\frac{(T_{\infty,1} - T_{\infty,2})}{k \left[ \frac{1}{h_1} + \frac{1}{h_2} + \frac{L}{k} \right]} \quad C_2 = -\frac{(T_{\infty,1} - T_{\infty,2})}{h_1 \left[ \frac{1}{h_1} + \frac{1}{h_2} + \frac{L}{k} \right]} + T_{\infty,1}$$

$$T(x) = -\frac{(T_{\infty,1} - T_{\infty,2})}{\left[ \frac{1}{h_1} + \frac{1}{h_2} + \frac{L}{k} \right]} \left[ \frac{x}{k} + \frac{1}{h_1} \right] + T_{\infty,1}. \quad <$$

From Fourier's law, the heat flux is a constant and of the form

$$q''_x = -k \frac{dT}{dx} = -k C_1 = +\frac{(T_{\infty,1} - T_{\infty,2})}{\left[ \frac{1}{h_1} + \frac{1}{h_2} + \frac{L}{k} \right]}. \quad <$$



### PROBLEM 3.2

**KNOWN:** Thickness of basement wall. Inner and outer wall temperatures. Thermal conductivity of aerated concrete.

**FIND:** Thickness of polystyrene insulation needed to reduce heat flux through the stone mix concrete wall to that of the aerated concrete wall. Lost annual rental income associated with specification of the stone mix concrete wall.

**SCHEMATIC:**

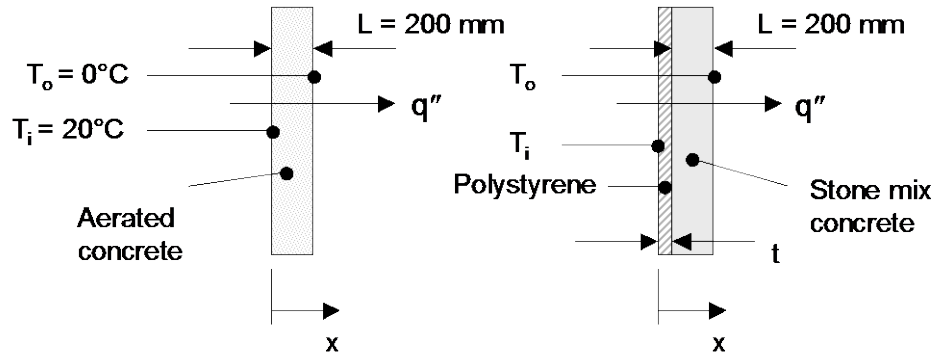

**ASSUMPTIONS:** (1) Steady-state, one-dimensional conduction, (2) Constant properties, (3) Negligible contact resistance.

**PROPERTIES:** Table A.3, Stone mix concrete (300 K):  $k_{sm} = 1.4 \text{ W/m}\cdot\text{K}$ ; Rigid extruded polystyrene sheet (285 K,  $\rho = 35 \text{ kg/m}^3$ ):  $k_{ps} = 0.027 \text{ W/m}\cdot\text{K}$ . Aerated concrete:  $k_{ac} = 0.15 \text{ W/m}\cdot\text{K}$  (given).

**ANALYSIS:** The heat flux through the aerated concrete is

$$q'' = k_{ac}(T_i - T_o)/L = 0.15 \text{ W/m}\cdot\text{K} \times (20^\circ\text{C} - 0^\circ\text{C})/0.20 \text{ m} = 15 \text{ W/m}^2 \quad (1)$$

The heat flux through the stone mix concrete and polystyrene sheet composite wall is

$$q'' = 15 \text{ W/m}^2 = \frac{T_i - T_o}{(t/k_{ps}) + (L/k_{sm})} = \frac{(20^\circ\text{C} - 0^\circ\text{C})}{(t/0.027 \text{ W/m}\cdot\text{K}) + (0.200 \text{ m}/1.4 \text{ W/m}\cdot\text{K})} \quad (2)$$

Hence,  $t = 0.032 \text{ m} = 32 \text{ mm}$ . <

The floor space occupied by the polystyrene insulation is  $A = 0.032 \text{ m} \times (20 \text{ m} + 30 \text{ m}) \times 2 = 3.2 \text{ m}^2$ . The lost annual revenue associated with specification of the stone mix concrete is  $\Delta R = \$50/\text{m}^2/\text{month} \times 12 \text{ months/year} \times 3.2 \text{ m}^2 = \$1920 \text{ per year}$ . <

**COMMENTS:** (1) Inclusion of the thermal contact resistance will reduce the value of the required insulation thickness. (2) A careful economic analysis would account for the difference in cost of the two materials. However, additional costs associated with specification of the stone mix concrete are labor costs for installation of the insulation, and the cost of the insulation itself. Additional costs for the aerated concrete wall are labor costs for constructing the wall of aerated concrete blocks. (3) Lightweight aerated concrete blocks are fabricated of recycled fly ash, a byproduct of coal combustion. The low thermal conductivity is due to small air bubbles that are entrapped within the solid matrix.

### PROBLEM 3.3

**KNOWN:** Temperatures and convection coefficients associated with air at the inner and outer surfaces of a rear window.

**FIND:** (a) Inner and outer window surface temperatures,  $T_{s,i}$  and  $T_{s,o}$ , and (b)  $T_{s,i}$  and  $T_{s,o}$  as a function of the outside air temperature  $T_{\infty,o}$  and for selected values of outer convection coefficient,  $h_o$ .

**SCHEMATIC:**

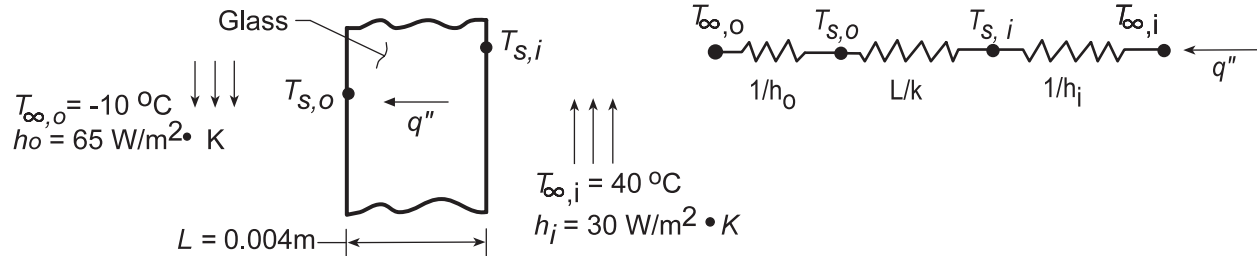

**ASSUMPTIONS:** (1) Steady-state conditions, (2) One-dimensional conduction, (3) Negligible radiation effects, (4) Constant properties.

**PROPERTIES:** Table A-3, Glass (300 K):  $k = 1.4\text{ W/m}\cdot\text{K}$ .

**ANALYSIS:** (a) The heat flux may be obtained from Eqs. 3.11 and 3.12,

$$q'' = \frac{T_{\infty,i} - T_{\infty,o}}{\frac{1}{h_o} + \frac{L}{k} + \frac{1}{h_i}} = \frac{40^\circ\text{C} - (-10^\circ\text{C})}{\frac{1}{65\text{ W/m}^2\cdot\text{K}} + \frac{0.004\text{ m}}{1.4\text{ W/m}\cdot\text{K}} + \frac{1}{30\text{ W/m}^2\cdot\text{K}}}$$

$$q'' = \frac{50^\circ\text{C}}{(0.0154 + 0.0029 + 0.0333)\text{ m}^2\cdot\text{K/W}} = 969\text{ W/m}^2.$$

Hence, with  $q'' = h_i (T_{\infty,i} - T_{s,o})$ , the inner surface temperature is

$$T_{s,i} = T_{\infty,i} - \frac{q''}{h_i} = 40^\circ\text{C} - \frac{969\text{ W/m}^2}{30\text{ W/m}^2\cdot\text{K}} = 7.7^\circ\text{C} \quad \leftarrow$$

Similarly for the outer surface temperature with  $q'' = h_o (T_{s,o} - T_{\infty,o})$  find

$$T_{s,o} = T_{\infty,o} + \frac{q''}{h_o} = -10^\circ\text{C} + \frac{969\text{ W/m}^2}{65\text{ W/m}^2\cdot\text{K}} = 4.9^\circ\text{C} \quad \leftarrow$$

(b) Using the same analysis,  $T_{s,i}$  and  $T_{s,o}$  have been computed and plotted as a function of the outside air temperature,  $T_{\infty,o}$ , for outer convection coefficients of  $h_o = 2, 65,$  and  $100\text{ W/m}^2\cdot\text{K}$ . As expected,  $T_{s,i}$  and  $T_{s,o}$  are linear with changes in the outside air temperature. The difference between  $T_{s,i}$  and  $T_{s,o}$  increases with increasing convection coefficient, since the heat flux through the window likewise increases. This difference is larger at lower outside air temperatures for the same reason. Note that with  $h_o = 2\text{ W/m}^2\cdot\text{K}$ ,  $T_{s,i} - T_{s,o}$ , is too small to show on the plot.

Continued ...

### PROBLEM 3.3 (Cont.)

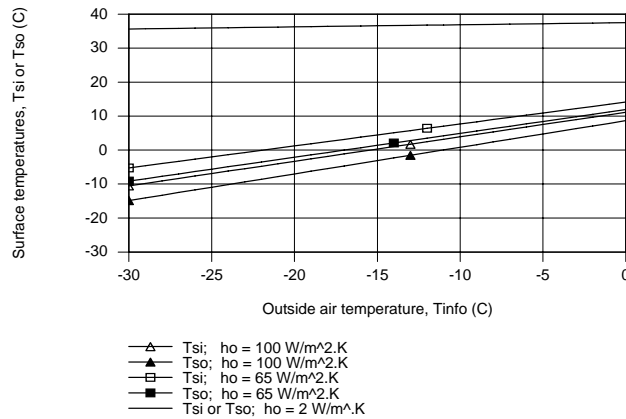

**COMMENTS:** (1) The largest resistance is that associated with convection at the inner surface. The values of  $T_{s,i}$  and  $T_{s,o}$  could be increased by increasing the value of  $h_i$ .

(2) The *IHT Thermal Resistance Network Model* was used to create a model of the window and generate the above plot. The Workspace is shown below.

**// Thermal Resistance Network Model:**

// The Network:

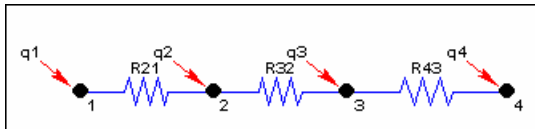

// Heat rates into node  $j$ ,  $q_j$ , through thermal resistance  $R_{ij}$

$$q_{21} = (T_2 - T_1) / R_{21}$$

$$q_{32} = (T_3 - T_2) / R_{32}$$

$$q_{43} = (T_4 - T_3) / R_{43}$$

// Nodal energy balances

$$q_1 + q_{21} = 0$$

$$q_2 - q_{21} + q_{32} = 0$$

$$q_3 - q_{32} + q_{43} = 0$$

$$q_4 - q_{43} = 0$$

/\* Assigned variables list: deselect the  $q_j$ ,  $R_{ij}$  and  $T_i$  which are unknowns; set  $q_i = 0$  for embedded nodal points at which there is no external source of heat. \*/

$T_1 = T_{info}$  // Outside air temperature, C

//  $q_1 =$  // Heat rate, W

$T_2 = T_{so}$  // Outer surface temperature, C

$q_2 = 0$  // Heat rate, W; node 2, no external heat source

$T_3 = T_{si}$  // Inner surface temperature, C

$q_3 = 0$  // Heat rate, W; node 3, no external heat source

$T_4 = T_{infi}$  // Inside air temperature, C

//  $q_4 =$  // Heat rate, W

**// Thermal Resistances:**

$R_{21} = 1 / (h_o * A_s)$  // Convection thermal resistance, K/W; outer surface

$R_{32} = L / (k * A_s)$  // Conduction thermal resistance, K/W; glass

$R_{43} = 1 / (h_i * A_s)$  // Convection thermal resistance, K/W; inner surface

**// Other Assigned Variables:**

$T_{info} = -10$  // Outside air temperature, C

$h_o = 65$  // Convection coefficient,  $W/m^2.K$ ; outer surface

$L = 0.004$  // Thickness, m; glass

$k = 1.4$  // Thermal conductivity,  $W/m.K$ ; glass

$T_{infi} = 40$  // Inside air temperature, C

$h_i = 30$  // Convection coefficient,  $W/m^2.K$ ; inner surface

$A_s = 1$  // Cross-sectional area,  $m^2$ ; unit area

### PROBLEM 3.4

**KNOWN:** Desired inner surface temperature of rear window with prescribed inside and outside air conditions.

**FIND:** (a) Heater power per unit area required to maintain the desired temperature, and (b) Compute and plot the electrical power requirement as a function of  $T_{\infty,o}$  for the range  $-30 \leq T_{\infty,o} \leq 0^\circ\text{C}$  with  $h_o$  of 2, 20, 65 and  $100 \text{ W/m}^2\cdot\text{K}$ . Comment on heater operation needs for low  $h_o$ . If  $h \sim V^n$ , where  $V$  is the vehicle speed and  $n$  is a positive exponent, how does the vehicle speed affect the need for heater operation?

**SCHEMATIC:**

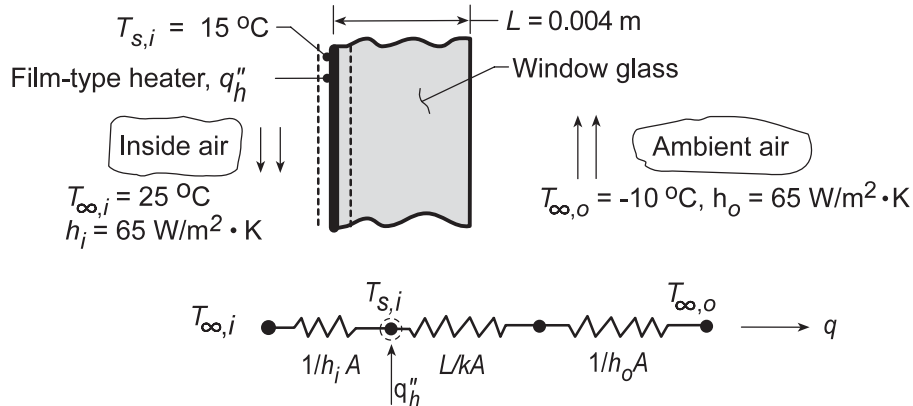

**ASSUMPTIONS:** (1) Steady-state conditions, (2) One-dimensional heat transfer, (3) Uniform heater flux,  $q_h''$ , (4) Constant properties, (5) Negligible radiation effects, (6) Negligible film resistance.

**PROPERTIES:** Table A-3, Glass (300 K):  $k = 1.4 \text{ W/m}\cdot\text{K}$ .

**ANALYSIS:** (a) From an energy balance at the inner surface and the thermal circuit, it follows that for a unit surface area,

$$\frac{T_{\infty,i} - T_{s,i}}{1/h_i} + q_h'' = \frac{T_{s,i} - T_{\infty,o}}{L/k + 1/h_o} \quad \text{and that} \quad q_h'' = \frac{T_{s,i} - T_{\infty,o}}{L/k + 1/h_o} - \frac{T_{\infty,i} - T_{s,i}}{1/h_i}$$

$$q_h'' = \frac{15^\circ\text{C} - (-10^\circ\text{C})}{\frac{0.004 \text{ m}}{1.4 \text{ W/m}\cdot\text{K}} + \frac{1}{65 \text{ W/m}^2\cdot\text{K}}} - \frac{25^\circ\text{C} - 15^\circ\text{C}}{10 \text{ W/m}^2\cdot\text{K}} = (1370 - 100) \text{ W/m}^2 = 1270 \text{ W/m}^2 \quad <$$

(b) The heater electrical power requirement as a function of the exterior air temperature for different exterior convection coefficients is shown in the plot. When  $h_o = 2 \text{ W/m}^2\cdot\text{K}$ , the heater is unnecessary, since the glass is maintained at  $15^\circ\text{C}$  by the interior air. If  $h \sim V^n$ , we conclude that, with higher vehicle speeds, the exterior convection will increase, requiring increased heat power to maintain the  $15^\circ\text{C}$  condition.

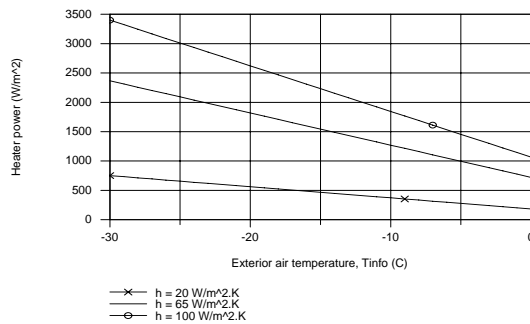

**COMMENTS:** With  $q_h'' = 0$ , the inner surface temperature with  $T_{\infty,o} = -10^\circ\text{C}$  would be given by

$$\frac{T_{\infty,i} - T_{s,i}}{T_{\infty,i} - T_{\infty,o}} = \frac{1/h_i}{1/h_i + L/k + 1/h_o} = \frac{0.10}{0.118} = 0.846, \quad \text{or} \quad T_{s,i} = 25^\circ\text{C} - 0.846(35^\circ\text{C}) = -4.6^\circ\text{C}.$$

### PROBLEM 3.5

**KNOWN:** Thermal conductivities and thicknesses of original wall, insulation layer, and glass layer. Interior and exterior air temperatures and convection heat transfer coefficients.

**FIND:** Heat flux through original and retrofitted walls.

**SCHEMATIC:**

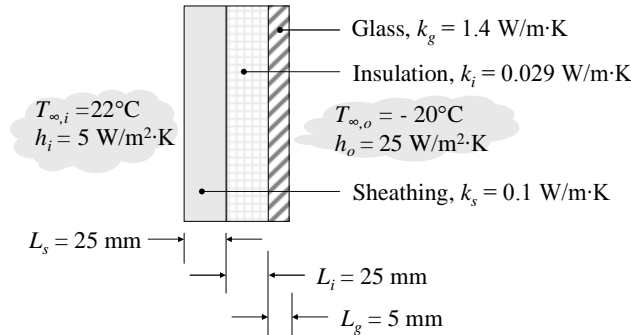

**ASSUMPTIONS:** (1) One-dimensional conduction, (2) Steady-state conditions, (3) Constant properties, (4) Negligible contact resistances.

**ANALYSIS:** The original wall with convection inside and outside can be represented by the following thermal resistance network, where the resistances are each for a unit area:

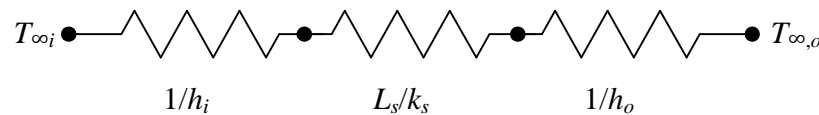

Thus the heat flux can be expressed as

$$q'' = \frac{T_{\infty,i} - T_{\infty,o}}{\frac{1}{h_i} + \frac{L_s}{k_s} + \frac{1}{h_o}} = \frac{22^\circ\text{C} - (-20^\circ\text{C})}{\frac{1}{5 \text{ W/m}^2 \cdot \text{K}} + \frac{0.025 \text{ m}}{0.1 \text{ W/m} \cdot \text{K}} + \frac{1}{25 \text{ W/m}^2 \cdot \text{K}}} = 85.7 \text{ W/m}^2 \quad <$$

The retrofitted wall has three layers. The thermal circuit can be represented as follows:

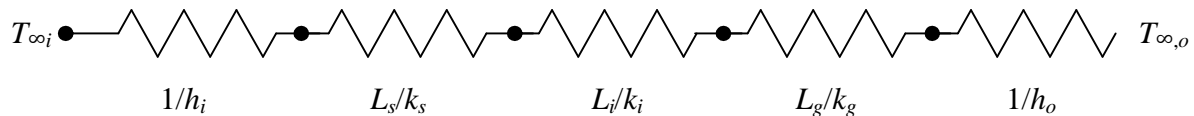

Thus the heat flux can be expressed as

$$q'' = \frac{T_{\infty,i} - T_{\infty,o}}{\frac{1}{h_i} + \frac{L_s}{k_s} + \frac{L_i}{k_i} + \frac{L_g}{k_g} + \frac{1}{h_o}} = \frac{22^\circ\text{C} - (-20^\circ\text{C})}{\frac{1}{5 \text{ W/m}^2 \cdot \text{K}} + \frac{0.025 \text{ m}}{0.1 \text{ W/m} \cdot \text{K}} + \frac{0.025 \text{ m}}{0.029 \text{ W/m} \cdot \text{K}} + \frac{0.005 \text{ m}}{1.4 \text{ W/m} \cdot \text{K}} + \frac{1}{25 \text{ W/m}^2 \cdot \text{K}}} = 31.0 \text{ W/m}^2 \quad <$$

**COMMENTS:** The heat flux has been reduced to approximately one-third of the original value because of the increased resistance, which is mainly due to the insulation layer.

### PROBLEM 3.6

**KNOWN:** Curing of a transparent film by radiant heating with substrate and film surface subjected to known thermal conditions.

**FIND:** (a) Thermal circuit for this situation, (b) Radiant heat flux,  $q_o''$  ( $\text{W}/\text{m}^2$ ), to maintain bond at curing temperature,  $T_o$ , (c) Compute and plot  $q_o''$  as a function of the film thickness for  $0 \leq L_f \leq 1$  mm, and (d) If the film is not transparent, determine  $q_o''$  required to achieve bonding; plot results as a function of  $L_f$ .

**SCHEMATIC:**

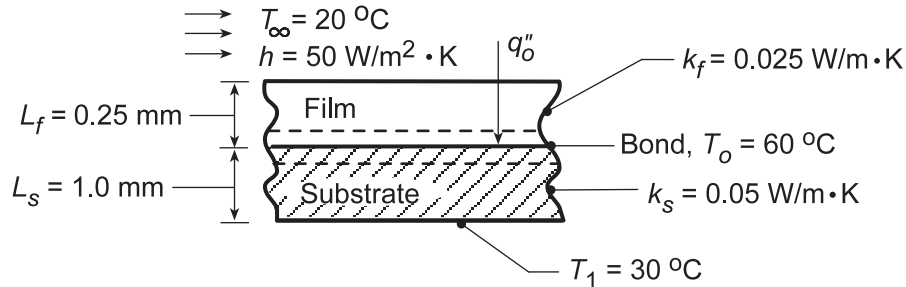

**ASSUMPTIONS:** (1) Steady-state conditions, (2) One-dimensional heat flow, (3) All the radiant heat flux  $q_o''$  is absorbed at the bond, (4) Negligible contact resistance.

**ANALYSIS:** (a) The thermal circuit for this situation is shown at the right. Note that terms are written on a per unit area basis.

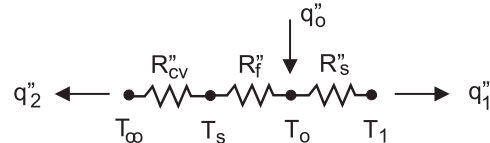

(b) Using this circuit and performing an energy balance on the film-substrate interface,

$$q_o'' = q_1'' + q_2'' \qquad q_o'' = \frac{T_o - T_\infty}{R_{cv}'' + R_f''} + \frac{T_o - T_1}{R_s''}$$

where the thermal resistances are

$$R_{cv}'' = 1/h = 1/50 \text{ W}/\text{m}^2 \cdot \text{K} = 0.020 \text{ m}^2 \cdot \text{K}/\text{W}$$

$$R_f'' = L_f/k_f = 0.00025 \text{ m}/0.025 \text{ W}/\text{m} \cdot \text{K} = 0.010 \text{ m}^2 \cdot \text{K}/\text{W}$$

$$R_s'' = L_s/k_s = 0.001 \text{ m}/0.05 \text{ W}/\text{m} \cdot \text{K} = 0.020 \text{ m}^2 \cdot \text{K}/\text{W}$$

$$q_o'' = \frac{(60 - 20)^\circ \text{C}}{[0.020 + 0.010] \text{ m}^2 \cdot \text{K}/\text{W}} + \frac{(60 - 30)^\circ \text{C}}{0.020 \text{ m}^2 \cdot \text{K}/\text{W}} = (1333 + 1500) \text{ W}/\text{m}^2 = 2833 \text{ W}/\text{m}^2 <$$

(c) For the transparent film, the radiant flux required to achieve bonding as a function of film thickness  $L_f$  is shown in the plot below.

(d) If the film is opaque (not transparent), the thermal circuit is shown below. In order to find  $q_o''$ , it is necessary to write two energy balances, one around the  $T_s$  node and the second about the  $T_o$  node.

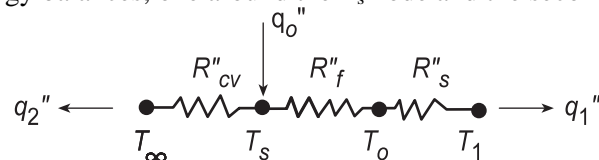

The results of the analysis are plotted below.

Continued...

### PROBLEM 3.6 (Cont.)

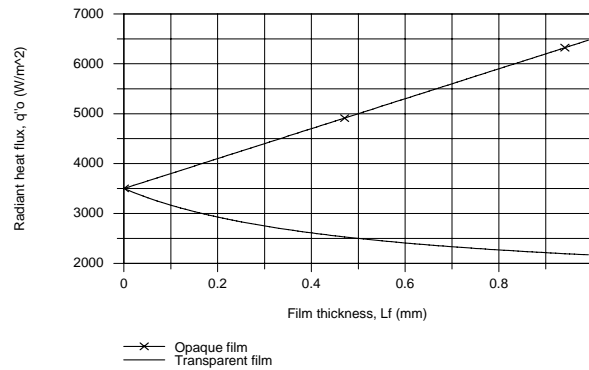

**COMMENTS:** (1) When the film is transparent, the radiant flux is absorbed on the bond. The flux required decreases with increasing film thickness. Physically, how do you explain this? Why is the relationship not linear?

(2) When the film is opaque, the radiant flux is absorbed on the surface, and the flux required increases with increasing thickness of the film. Physically, how do you explain this? Why is the relationship linear?

(3) The IHT Thermal Resistance Network Model was used to create a model of the film-substrate system and generate the above plot. The Workspace is shown below.

#### // Thermal Resistance Network

##### Model:

// The Network:

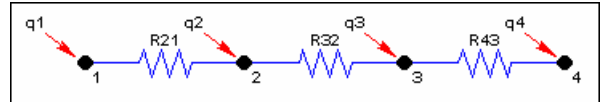

// Heat rates into node  $j$ ,  $q_j$ , through thermal resistance  $R_{ij}$

$$q_{21} = (T_2 - T_1) / R_{21}$$

$$q_{32} = (T_3 - T_2) / R_{32}$$

$$q_{43} = (T_4 - T_3) / R_{43}$$

// Nodal energy balances

$$q_1 + q_{21} = 0$$

$$q_2 - q_{21} + q_{32} = 0$$

$$q_3 - q_{32} + q_{43} = 0$$

$$q_4 - q_{43} = 0$$

/\* Assigned variables list: deselect the  $q_i$ ,  $R_{ij}$  and  $T_i$  which are unknowns; set  $q_i = 0$  for embedded nodal points at which there is no external source of heat. \*/

$T_1 = T_{inf}$  // Ambient air temperature, C

//  $q_1 =$  // Heat rate, W; film side

$T_2 = T_s$  // Film surface temperature, C

$q_2 = 0$  // Radiant flux, W/m<sup>2</sup>; zero for part (a)

$T_3 = T_o$  // Bond temperature, C

$q_3 = q_o$  // Radiant flux, W/m<sup>2</sup>; part (a)

$T_4 = T_{sub}$  // Substrate temperature, C

//  $q_4 =$  // Heat rate, W; substrate side

#### // Thermal Resistances:

$R_{21} = 1 / (h * A_s)$  // Convection resistance, K/W

$R_{32} = L_f / (k_f * A_s)$  // Conduction resistance, K/W; film

$R_{43} = L_s / (k_s * A_s)$  // Conduction resistance, K/W; substrate

#### // Other Assigned Variables:

$T_{inf} = 20$  // Ambient air temperature, C

$h = 50$  // Convection coefficient, W/m<sup>2</sup>.K

$L_f = 0.00025$  // Thickness, m; film

$k_f = 0.025$  // Thermal conductivity, W/m.K; film

$T_o = 60$  // Cure temperature, C

$L_s = 0.001$  // Thickness, m; substrate

$k_s = 0.05$  // Thermal conductivity, W/m.K; substrate

$T_{sub} = 30$  // Substrate temperature, C

$A_s = 1$  // Cross-sectional area, m<sup>2</sup>; unit area

### PROBLEM 3.7

**KNOWN:** Thicknesses and thermal conductivities of refrigerator wall materials. Inner and outer air temperatures and convection coefficients.

**FIND:** Heat gain per surface area.

**SCHEMATIC:**

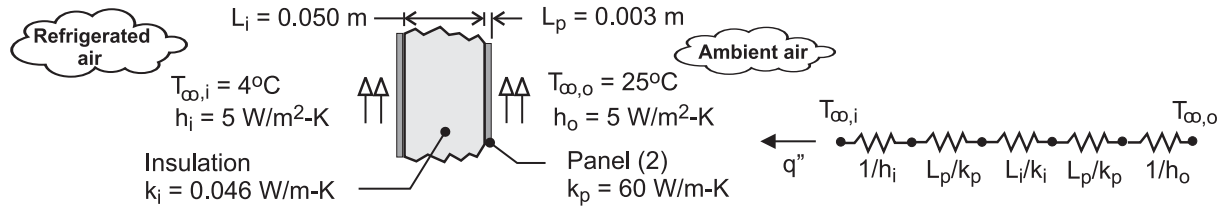

**ASSUMPTIONS:** (1) One-dimensional heat transfer, (2) Steady-state conditions, (3) Negligible contact resistance, (4) Negligible radiation, (5) Constant properties.

**ANALYSIS:** From the thermal circuit, the heat gain per unit surface area is

$$q'' = \frac{T_{\infty,o} - T_{\infty,i}}{(1/h_i) + (L_p/k_p) + (L_i/k_i) + (L_p/k_p) + (1/h_o)}$$

$$q'' = \frac{(25 - 4)^\circ\text{C}}{2\left(1/5 \text{ W/m}^2 \cdot \text{K}\right) + 2(0.003\text{m}/60 \text{ W/m} \cdot \text{K}) + (0.050\text{m}/0.046 \text{ W/m} \cdot \text{K})}$$

$$q'' = \frac{21^\circ\text{C}}{(0.4 + 0.0001 + 1.087) \text{ m}^2 \cdot \text{K/W}} = 14.1 \text{ W/m}^2 \quad \leftarrow$$

**COMMENTS:** Although the contribution of the panels to the total thermal resistance is negligible, that due to convection is not inconsequential and is comparable to the thermal resistance of the insulation.



### PROBLEM 3.8

**KNOWN:** Top and bottom temperatures applied to a water layer of known thickness.

**FIND:** Steady-state location of the solid-liquid interface.

**SCHEMATIC:**

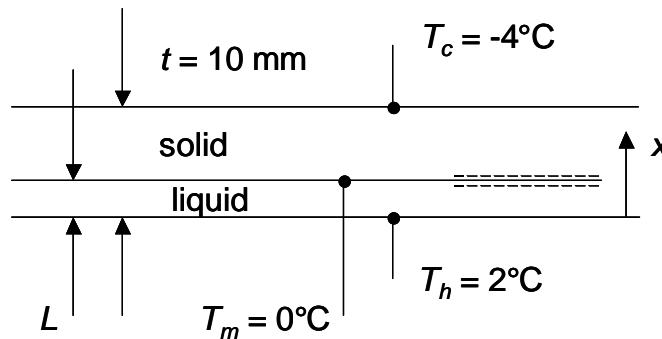

**ASSUMPTIONS:** (1) Steady-state conditions, (2) Constant properties, (3) Negligible radiation, (4) Negligible convection in the liquid.

**PROPERTIES:** Table A.6, liquid water ( $T = 273 \text{ K}$ ):  $k_f = 0.569 \text{ W/m}\cdot\text{K}$ ; Table A.3, ice ( $T = 0 \text{ K}$ ),  $k_s = 1.88 \text{ W/m}\cdot\text{K}$ .

**ANALYSIS:** An energy balance at the control surface shown in the schematic yields

$$k_f(T_h - T_m)/L = k_s(T_m - T_c)/(t - L)$$

or

$$L = \frac{t}{\left(\frac{k_s(T_m - T_c)}{k_f(T_h - T_m)} + 1\right)} = \frac{10 \times 10^{-3} \text{ m}}{\left(\frac{1.88 \text{ W/m}\cdot\text{K}(0^\circ\text{C} - (-4^\circ\text{C}))}{0.569 \text{ W/m}\cdot\text{K}(2^\circ\text{C} - 0^\circ\text{C})} + 1\right)} = 1.31 \times 10^{-3} \text{ m} = 1.31 \text{ mm} \quad <$$

**COMMENTS:** (1) Liquid water is opaque to thermal radiation, but ice is semi-transparent. A more detailed analysis would account for the effects of radiation. (2) Free convection in the liquid is negligible because the density of liquid water at  $T_h = 2^\circ\text{C}$  is greater than the density at  $T_m = 0^\circ\text{C}$ . Water is one of only several liquids that experiences such a *density inversion*.

### PROBLEM 3.9

**KNOWN:** Design and operating conditions of a heat flux gage.

**FIND:** (a) Convection coefficient for water flow ( $T_s = 27^\circ\text{C}$ ) and error associated with neglecting conduction in the insulation, (b) Convection coefficient for air flow ( $T_s = 125^\circ\text{C}$ ) and error associated with neglecting conduction and radiation, (c) Effect of convection coefficient on error associated with neglecting conduction for  $T_s = 27^\circ\text{C}$ .

**SCHEMATIC:**

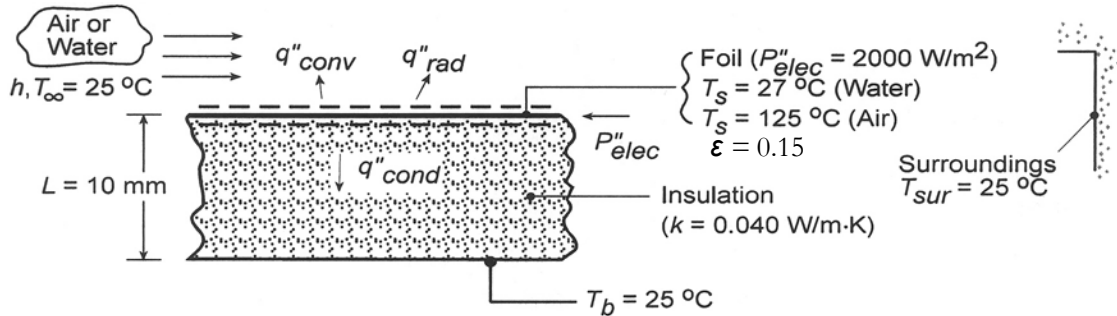

**ASSUMPTIONS:** (1) Steady-state, (2) One-dimensional conduction, (3) Constant  $k$ .

**ANALYSIS:** (a) The electric power dissipation is balanced by convection to the water and conduction through the insulation. An energy balance applied to a control surface about the foil therefore yields

$$P''_{elec} = q''_{conv} + q''_{cond} = h(T_s - T_\infty) + k(T_s - T_b)/L$$

Hence,

$$h = \frac{P''_{elec} - k(T_s - T_b)/L}{T_s - T_\infty} = \frac{2000 \text{ W/m}^2 - 0.04 \text{ W/m} \cdot \text{K} (2 \text{ K})/0.01 \text{ m}}{2 \text{ K}}$$

$$h = \frac{(2000 - 8) \text{ W/m}^2}{2 \text{ K}} = 996 \text{ W/m}^2 \cdot \text{K} \quad <$$

If conduction is neglected, a value of  $h = 1000 \text{ W/m}^2 \cdot \text{K}$  is obtained, with an attendant error of  $(1000 - 996)/996 = 0.40\%$

(b) In air, energy may also be transferred from the foil surface by radiation, and the energy balance yields

$$P''_{elec} = q''_{conv} + q''_{rad} + q''_{cond} = h(T_s - T_\infty) + \epsilon\sigma(T_s^4 - T_{sur}^4) + k(T_s - T_b)/L$$

Hence,

$$h = \frac{P''_{elec} - \epsilon\sigma(T_s^4 - T_{sur}^4) - k(T_s - T_\infty)/L}{T_s - T_\infty}$$

$$= \frac{2000 \text{ W/m}^2 - 0.15 \times 5.67 \times 10^{-8} \text{ W/m}^2 \cdot \text{K}^4 (398^4 - 298^4) - 0.04 \text{ W/m} \cdot \text{K} (100 \text{ K})/0.01 \text{ m}}{100 \text{ K}}$$

$$= \frac{(2000 - 146 - 400) \text{ W/m}^2}{100 \text{ K}} = 14.5 \text{ W/m}^2 \cdot \text{K} \quad <$$

Continued...

### PROBLEM 3.9 (Cont.)

If conduction, radiation, or conduction and radiation are neglected, the corresponding values of  $h$  and the percentage errors are  $18.5 \text{ W/m}^2\cdot\text{K}$  (27.6%),  $16 \text{ W/m}^2\cdot\text{K}$  (10.3%), and  $20 \text{ W/m}^2\cdot\text{K}$  (37.9%).

(c) For a fixed value of  $T_s = 27^\circ\text{C}$ , the conduction loss remains at  $q''_{\text{cond}} = 8 \text{ W/m}^2$ , which is also the fixed difference between  $P''_{\text{elec}}$  and  $q''_{\text{conv}}$ . Although this difference is not clearly shown in the plot for  $10 \leq h \leq 1000 \text{ W/m}^2\cdot\text{K}$ , it is revealed in the subplot for  $10 \leq 100 \text{ W/m}^2\cdot\text{K}$ .

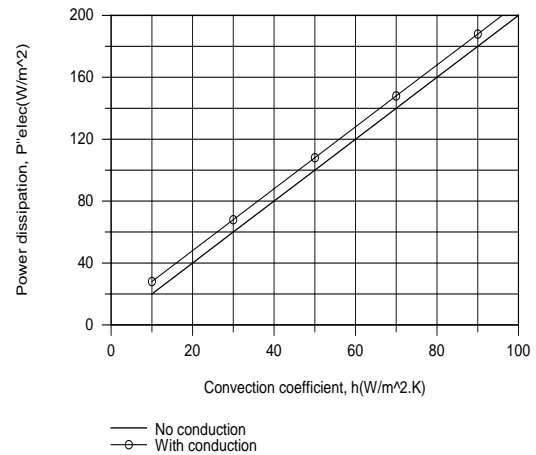
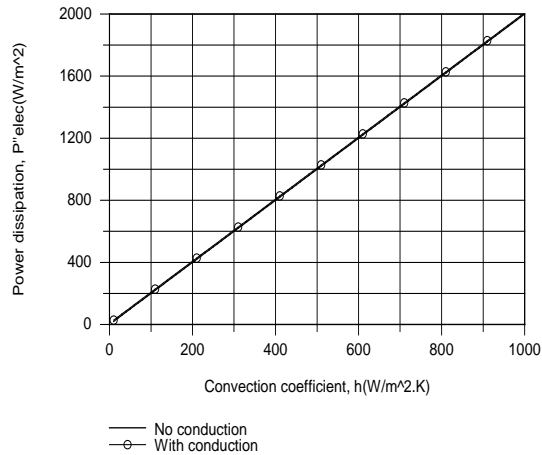

Errors associated with neglecting conduction decrease with increasing  $h$  from values which are significant for small  $h$  ( $h < 100 \text{ W/m}^2\cdot\text{K}$ ) to values which are negligible for large  $h$ .

**COMMENTS:** In liquids (large  $h$ ), it is an excellent approximation to neglect conduction and assume that all of the dissipated power is transferred to the fluid.

### PROBLEM 3.10

**KNOWN:** A layer of fatty tissue with fixed inside temperature can experience different outside convection conditions.

**FIND:** (a) Ratio of heat loss for different convection conditions, (b) Outer surface temperature for different convection conditions, and (c) Temperature of still air which achieves same cooling as moving air (*wind chill* effect).

**SCHEMATIC:**

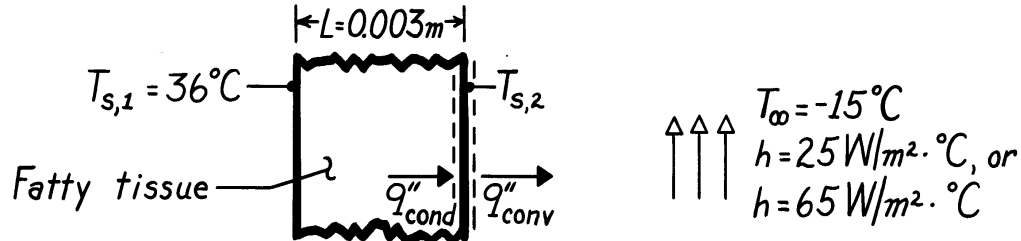

**ASSUMPTIONS:** (1) One-dimensional conduction through a plane wall, (2) Steady-state conditions, (3) Homogeneous medium with constant properties, (4) No internal heat generation (metabolic effects are negligible), (5) Negligible radiation effects.

**PROPERTIES:** Table A-3, Tissue, fat layer:  $k = 0.2 \text{ W/m}\cdot\text{K}$ .

**ANALYSIS:** The thermal circuit for this situation is

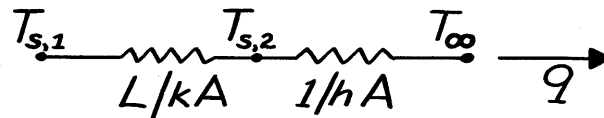

Hence, the heat rate is

$$q = \frac{T_{s,1} - T_{\infty}}{R_{\text{tot}}} = \frac{T_{s,1} - T_{\infty}}{L/kA + 1/hA}.$$

Therefore,

$$\frac{q''_{\text{calm}}}{q''_{\text{windy}}} = \frac{\left[ \frac{L}{k} + \frac{1}{h} \right]_{\text{windy}}}{\left[ \frac{L}{k} + \frac{1}{h} \right]_{\text{calm}}}.$$

Applying a surface energy balance to the outer surface, it also follows that

$$q''_{\text{cond}} = q''_{\text{conv}}.$$

Continued ...

**PROBLEM 3.10 (Cont.)**

Hence,

$$\frac{k}{L}(T_{s,1} - T_{s,2}) = h(T_{s,2} - T_{\infty})$$

$$T_{s,2} = \frac{T_{\infty} + \frac{k}{hL}T_{s,1}}{1 + \frac{k}{hL}}$$

To determine the wind chill effect, we must determine the heat loss for the windy day and use it to evaluate the hypothetical ambient air temperature,  $T'_{\infty}$ , which would provide the same heat loss on a calm day, Hence,

$$q'' = \frac{T_{s,1} - T_{\infty}}{\left[\frac{L}{k} + \frac{1}{h}\right]_{\text{windy}}} = \frac{T_{s,1} - T'_{\infty}}{\left[\frac{L}{k} + \frac{1}{h}\right]_{\text{calm}}}$$

From these relations, we can now find the results sought:

$$(a) \quad \frac{q''_{\text{calm}}}{q''_{\text{windy}}} = \frac{\frac{0.003 \text{ m}}{0.2 \text{ W/m} \cdot \text{K}} + \frac{1}{65 \text{ W/m}^2 \cdot \text{K}}}{\frac{0.003 \text{ m}}{0.2 \text{ W/m} \cdot \text{K}} + \frac{1}{25 \text{ W/m}^2 \cdot \text{K}}} = \frac{0.015 + 0.0154}{0.015 + 0.04}$$

$$\frac{q''_{\text{calm}}}{q''_{\text{windy}}} = 0.553 \quad <$$

$$(b) \quad T_{s,2}]_{\text{calm}} = \frac{-15^{\circ}\text{C} + \frac{0.2 \text{ W/m} \cdot \text{K}}{(25 \text{ W/m}^2 \cdot \text{K})(0.003 \text{ m})} 36^{\circ}\text{C}}{1 + \frac{0.2 \text{ W/m} \cdot \text{K}}{(25 \text{ W/m}^2 \cdot \text{K})(0.003 \text{ m})}} = 22.1^{\circ}\text{C} \quad <$$

$$T_{s,2}]_{\text{windy}} = \frac{-15^{\circ}\text{C} + \frac{0.2 \text{ W/m} \cdot \text{K}}{(65 \text{ W/m}^2 \cdot \text{K})(0.003 \text{ m})} 36^{\circ}\text{C}}{1 + \frac{0.2 \text{ W/m} \cdot \text{K}}{(65 \text{ W/m}^2 \cdot \text{K})(0.003 \text{ m})}} = 10.8^{\circ}\text{C} \quad <$$

$$(c) \quad T'_{\infty} = 36^{\circ}\text{C} - (36 + 15)^{\circ}\text{C} \frac{(0.003/0.2 + 1/25)}{(0.003/0.2 + 1/65)} = -56.3^{\circ}\text{C} \quad <$$

**COMMENTS:** The wind chill effect is equivalent to a decrease of  $T_{s,2}$  by  $11.3^{\circ}\text{C}$  and increase in the heat loss by a factor of  $(0.553)^{-1} = 1.81$ .

### PROBLEM 3.11

**KNOWN:** Temperature of the heating island and sensing island, as well as the surrounding silicon nitride wafer temperature of Example 3.4.

**FIND:** The thermal conductivity of the carbon nanotube,  $k_{\text{cn}}$ , for the conditions of the problem statement and  $T_h = 332.6 \text{ K}$ , without evaluating the thermal resistances of the supports.

**SCHEMATIC:**

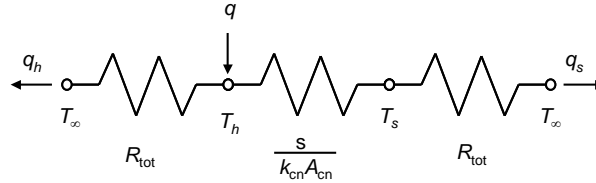

**ASSUMPTIONS:** (1) Steady-state conditions, (2) Constant properties, (3) One-dimensional heat transfer, (4) Isothermal heating and sensing islands, (5) Negligible radiation and convection effects.

**ANALYSIS:** We begin by defining an *excess temperature*,  $\theta \equiv T - T_\infty$  and modifying the thermal circuit as shown in the schematic. In the modified circuit, the total thermal resistance,  $R_{\text{tot}}$ , represents the combined effects of the two beams that support either the heated island or the sensing island.

From the modified thermal circuit, it is evident that an expression for  $R_{\text{tot}}$  can be derived as

$$q = q_h + q_s = \frac{T_h - T_\infty}{R_{\text{tot}}} + \frac{T_s - T_\infty}{R_{\text{tot}}} = \frac{\theta_h + \theta_s}{R_{\text{tot}}} \quad \text{or} \quad R_{\text{tot}} = \frac{\theta_h + \theta_s}{q}$$

For conduction through the supporting beams of the heated island, and through the carbon nanotube, we may write

$$q = q_h + q_s = \frac{T_h - T_\infty}{R_{\text{tot}}} + \frac{T_h - T_s}{s/(k_{\text{cn}}A_{\text{cn}})} = \frac{\theta_h}{R_{\text{tot}}} + \frac{\theta_h - \theta_s}{s/(k_{\text{cn}}A_{\text{cn}})}$$

Substituting the expression for  $R_{\text{tot}}$  into the preceding equation, and rearranging the resulting expression yields

$$k_{\text{cn}} = \left[ 1 - \frac{\theta_h}{\theta_h + \theta_s} \right] \left[ \frac{1}{\theta_h - \theta_s} \right] \frac{sq}{A_{\text{cn}}} = \left[ 1 - \frac{32.6 \text{ K}}{32.6 \text{ K} + 8.4 \text{ K}} \right] \left[ \frac{1}{32.6 \text{ K} - 8.4 \text{ K}} \right] \frac{5 \times 10^{-6} \text{ m} \times 11.3 \times 10^{-6} \text{ W}}{1.54 \times 10^{-16} \text{ m}^2}$$

$$= 3113 \text{ W/m}\cdot\text{K} \quad \leftarrow$$

**COMMENTS:** (1) The analysis is simplified if the heating island temperature is known. (2) This solution is independent of the thermal resistance posed by the support beams, making the measured thermal conductivity of the carbon nanotube less susceptible to experimental error.

### PROBLEM 3.12

**KNOWN:** Dimensions of a thermopane window. Room and ambient air conditions.

**FIND:** (a) Heat loss through window, (b) Effect of variation in outside convection coefficient for double and triple pane construction.

**SCHEMATIC (Double Pane):**

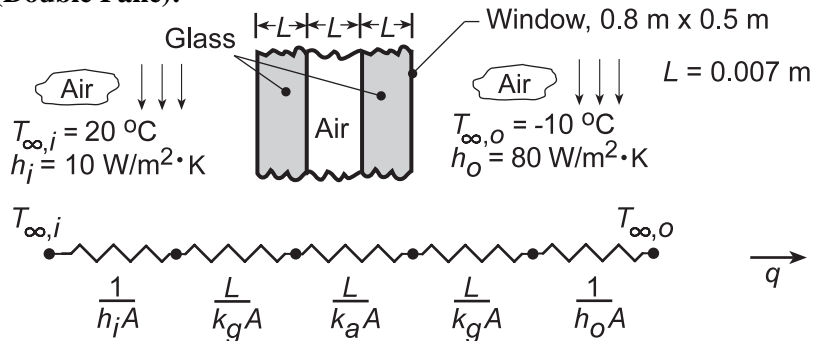

**ASSUMPTIONS:** (1) Steady-state conditions, (2) One-dimensional heat transfer, (3) Constant properties, (4) Neglect radiation effects, (5) Air between glass is stagnant.

**PROPERTIES:** Table A-3, Glass (300 K):  $k_g = 1.4 \text{ W/m}\cdot\text{K}$ ; Table A-4, Air ( $T = 278 \text{ K}$ ):  $k_a = 0.0245 \text{ W/m}\cdot\text{K}$ .

**ANALYSIS:** (a) From the thermal circuit, the heat loss is

$$q = \frac{T_{\infty,i} - T_{\infty,o}}{\frac{1}{A} \left( \frac{1}{h_i} + \frac{L}{k_g} + \frac{L}{k_a} + \frac{L}{k_g} + \frac{1}{h_o} \right)}$$

$$q = \frac{20^\circ\text{C} - (-10^\circ\text{C})}{\left( \frac{1}{0.4\text{m}^2} \right) \left( \frac{1}{10\text{W/m}^2\cdot\text{K}} + \frac{0.007\text{m}}{1.4\text{W/m}\cdot\text{K}} + \frac{0.007\text{m}}{0.0245\text{W/m}\cdot\text{K}} + \frac{0.007\text{m}}{1.4\text{W/m}\cdot\text{K}} + \frac{1}{80\text{W/m}^2\cdot\text{K}} \right)}$$

$$q = \frac{30^\circ\text{C}}{(0.25 + 0.0125 + 0.715 + 0.0125 + 0.03125)\text{K/W}} = \frac{30^\circ\text{C}}{1.021\text{K/W}} = 29.4 \text{ W} \quad \leftarrow$$

(b) For the triple pane window, the additional pane and airspace increase the total resistance from 1.021 K/W to 1.749 K/W, thereby reducing the heat loss from 29.4 to 17.2 W. The effect of  $h_o$  on the heat loss is plotted as follows.

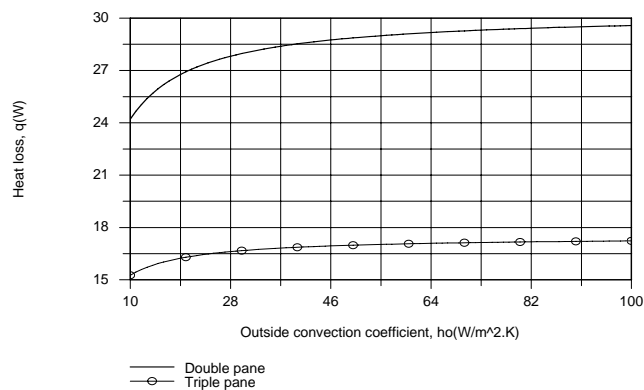

Continued...

### PROBLEM 3.12 (Cont.)

Changes in  $h_o$  influence the heat loss at small values of  $h_o$ , for which the outside convection resistance is not negligible relative to the total resistance. However, the resistance becomes negligible with increasing  $h_o$ , particularly for the triple pane window, and changes in  $h_o$  have little effect on the heat loss.

**COMMENTS:** (1) The largest contribution to the thermal resistance is due to conduction across the enclosed air. Note that this air could be in motion due to free convection currents. If the corresponding convection coefficient exceeded  $3.5 \text{ W/m}^2\cdot\text{K}$ , the thermal resistance would be less than that predicted by assuming conduction across stagnant air, thereby increasing the heat loss.

(2) Determination of the radiation heat loss is complex and will be addressed in Chapters 12 and 13. Radiation would increase the heat loss between the room and outside air, but on a sunny day, solar radiation transmitted through the window would contribute to heating the room.



### PROBLEM 3.13

**KNOWN:** Composite wall of a house with prescribed convection processes at inner and outer surfaces.

**FIND:** (a) Expression for thermal resistance of house wall,  $R_{\text{tot}}$ ; (b) Total heat loss,  $q$  (W); (c) Effect on heat loss due to increase in outside heat transfer convection coefficient,  $h_o$ ; and (d) Controlling resistance for heat loss from house.

**SCHEMATIC:**

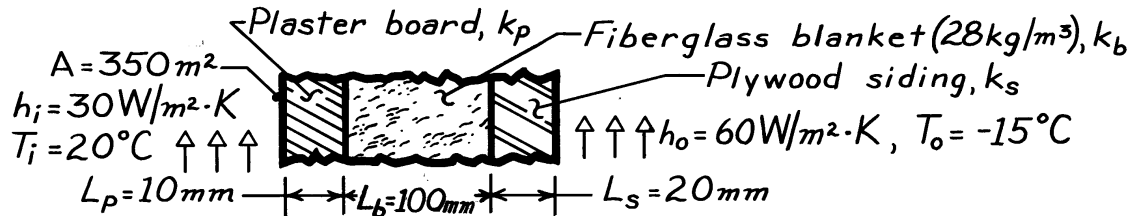

**ASSUMPTIONS:** (1) One-dimensional conduction, (2) Steady-state conditions, (3) Negligible contact resistance.

**PROPERTIES:** Table A-3,  $(\bar{T} = (T_i + T_o)/2 = (20 - 15)^\circ \text{C}/2 = 2.5^\circ \text{C} \approx 300 \text{K})$ : Fiberglass blanket,  $28 \text{ kg/m}^3$ ,  $k_b = 0.038 \text{ W/m} \cdot \text{K}$ ; Plywood siding,  $k_s = 0.12 \text{ W/m} \cdot \text{K}$ ; Plasterboard,  $k_p = 0.17 \text{ W/m} \cdot \text{K}$ .

**ANALYSIS:** (a) The expression for the total thermal resistance of the house wall follows from Eq. 3.18.

$$R_{\text{tot}} = \frac{1}{h_i A} + \frac{L_p}{k_p A} + \frac{L_b}{k_b A} + \frac{L_s}{k_s A} + \frac{1}{h_o A} \quad <$$

(b) The total heat loss through the house wall is

$$q = \Delta T / R_{\text{tot}} = (T_i - T_o) / R_{\text{tot}}$$

Substituting numerical values, find

$$R_{\text{tot}} = \frac{1}{30 \text{ W/m}^2 \cdot \text{K} \times 350 \text{ m}^2} + \frac{0.01 \text{ m}}{0.17 \text{ W/m} \cdot \text{K} \times 350 \text{ m}^2} + \frac{0.10 \text{ m}}{0.038 \text{ W/m} \cdot \text{K} \times 350 \text{ m}^2} + \frac{0.02 \text{ m}}{0.12 \text{ W/m} \cdot \text{K} \times 350 \text{ m}^2} + \frac{1}{60 \text{ W/m}^2 \cdot \text{K} \times 350 \text{ m}^2}$$

$$R_{\text{tot}} = [9.52 + 16.8 + 752 + 47.6 + 4.76] \times 10^{-5} \text{ }^\circ \text{C/W} = 831 \times 10^{-5} \text{ }^\circ \text{C/W}$$

The heat loss is then,

$$q = [20 - (-15)]^\circ \text{C} / 831 \times 10^{-5} \text{ }^\circ \text{C/W} = 4.21 \text{ kW} \quad <$$

(c) If  $h_o$  changes from  $60$  to  $300 \text{ W/m}^2 \cdot \text{K}$ ,  $R_o = 1/h_o A$  changes from  $4.76 \times 10^{-5} \text{ }^\circ \text{C/W}$  to  $0.95 \times 10^{-5} \text{ }^\circ \text{C/W}$ . This reduces  $R_{\text{tot}}$  to  $826 \times 10^{-5} \text{ }^\circ \text{C/W}$ , which is a 0.6% decrease and hence a 0.6% increase in  $q$ .

(d) From the expression for  $R_{\text{tot}}$  in part (b), note that the insulation resistance,  $L_b/k_b A$ , is  $752/830 \approx 90\%$  of the total resistance. Hence, this material layer controls the resistance of the wall. From part (c) note that a 5-fold decrease in the outer convection resistance due to an increase in the wind velocity has a negligible effect on the heat loss.

### PROBLEM 3.14

**KNOWN:** Composite wall of a house with prescribed convection processes at inner and outer surfaces.

**FIND:** Daily heat loss for prescribed diurnal variation in ambient air temperature.

**SCHEMATIC:**

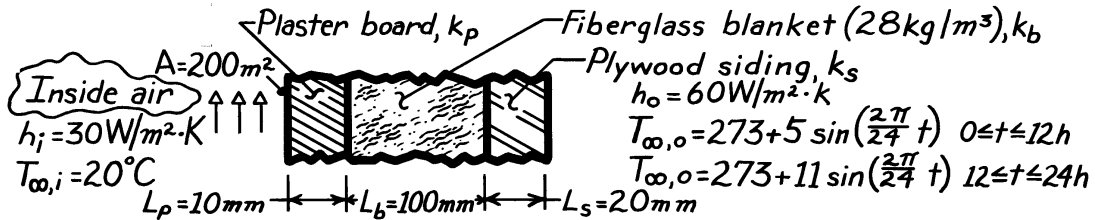

**ASSUMPTIONS:** (1) One-dimensional, steady-state conduction (negligible change in wall thermal energy storage over 24h period), (2) Negligible contact resistance.

**PROPERTIES:** Table A-3,  $T \approx 300$  K: Fiberglass blanket ( $28 \text{ kg/m}^3$ ),  $k_b = 0.038 \text{ W/m}\cdot\text{K}$ ; Plywood,  $k_s = 0.12 \text{ W/m}\cdot\text{K}$ ; Plasterboard,  $k_p = 0.17 \text{ W/m}\cdot\text{K}$ .

**ANALYSIS:** The heat loss may be approximated as  $Q = \int_0^{24\text{h}} \frac{T_{\infty,i} - T_{\infty,o}}{R_{\text{tot}}} dt$  where

$$R_{\text{tot}} = \frac{1}{A} \left[ \frac{1}{h_i} + \frac{L_p}{k_p} + \frac{L_b}{k_b} + \frac{L_s}{k_s} + \frac{1}{h_o} \right]$$

$$R_{\text{tot}} = \frac{1}{200\text{m}^2} \left[ \frac{1}{30 \text{ W/m}^2 \cdot \text{K}} + \frac{0.01\text{m}}{0.17 \text{ W/m}\cdot\text{K}} + \frac{0.1\text{m}}{0.038 \text{ W/m}\cdot\text{K}} + \frac{0.02\text{m}}{0.12 \text{ W/m}\cdot\text{K}} + \frac{1}{60 \text{ W/m}^2 \cdot \text{K}} \right]$$

$$R_{\text{tot}} = 0.01454 \text{ K/W.}$$

Hence the heat rate is

$$Q = \frac{1}{R_{\text{tot}}} \left\{ \int_0^{12\text{h}} \left[ 293 - \left[ 273 + 5 \sin \frac{2\pi}{24} t \right] \right] dt + \int_{12}^{24\text{h}} \left[ 293 - \left[ 273 + 11 \sin \frac{2\pi}{24} t \right] \right] dt \right\}$$

$$Q = 68.8 \frac{\text{W}}{\text{K}} \left\{ \left[ 20t + 5 \left[ \frac{24}{2\pi} \right] \cos \frac{2\pi t}{24} \right] \Big|_0^{12} + \left[ 20t + 11 \left[ \frac{24}{2\pi} \right] \cos \frac{2\pi t}{24} \right] \Big|_{12}^{24} \right\} \text{K}\cdot\text{h}$$

$$Q = 68.8 \left\{ \left[ 240 + \frac{60}{\pi} (-1 - 1) \right] + \left[ 480 - 240 + \frac{132}{\pi} (1 + 1) \right] \right\} \text{W}\cdot\text{h}$$

$$Q = 68.8 \{ 480 - 38.2 + 84.03 \} \text{W}\cdot\text{h}$$

$$Q = 36.18 \text{ kW}\cdot\text{h} = 1.302 \times 10^8 \text{ J.}$$

**COMMENTS:** From knowledge of the fuel cost, the total daily heating bill could be determined. For example, at a cost of 0.18\$/kW·h, the heating bill would be \$6.52/day.

### PROBLEM 3.15

**KNOWN:** Dimensions and materials associated with a composite wall (2.5m × 6.5m, 10 studs each 2.5m high).

**FIND:** Wall thermal resistance.

**SCHEMATIC:**

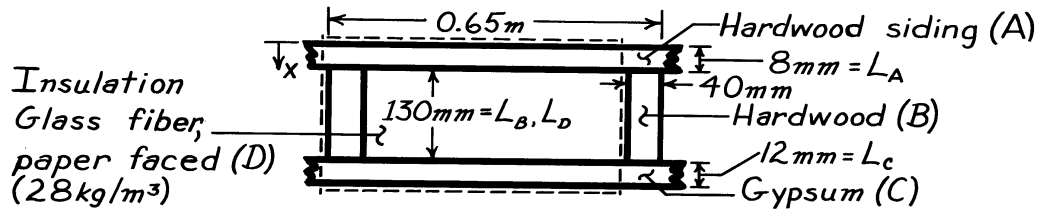

**ASSUMPTIONS:** (1) Steady-state conditions, (2) Temperature of composite depends only on  $x$  (surfaces normal to  $x$  are isothermal), (3) Constant properties, (4) Negligible contact resistance.

**PROPERTIES:** Table A-3 ( $T \approx 300\text{K}$ ): Hardwood siding,  $k_A = 0.094 \text{ W/m}\cdot\text{K}$ ; Hardwood,  $k_B = 0.16 \text{ W/m}\cdot\text{K}$ ; Gypsum,  $k_C = 0.17 \text{ W/m}\cdot\text{K}$ ; Insulation (glass fiber paper faced,  $28 \text{ kg/m}^3$ ),  $k_D = 0.038 \text{ W/m}\cdot\text{K}$ .

**ANALYSIS:** Using the isothermal surface assumption, the thermal circuit associated with a single unit (enclosed by dashed lines) of the wall is

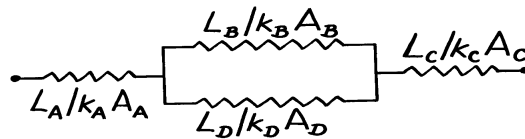

$$(L_A / k_A A_A) = \frac{0.008\text{m}}{0.094 \text{ W/m}\cdot\text{K} (0.65\text{m} \times 2.5\text{m})} = 0.0524 \text{ K/W}$$

$$(L_B / k_B A_B) = \frac{0.13\text{m}}{0.16 \text{ W/m}\cdot\text{K} (0.04\text{m} \times 2.5\text{m})} = 8.125 \text{ K/W}$$

$$(L_D / k_D A_D) = \frac{0.13\text{m}}{0.038 \text{ W/m}\cdot\text{K} (0.61\text{m} \times 2.5\text{m})} = 2.243 \text{ K/W}$$

$$(L_C / k_C A_C) = \frac{0.012\text{m}}{0.17 \text{ W/m}\cdot\text{K} (0.65\text{m} \times 2.5\text{m})} = 0.0434 \text{ K/W}.$$

The equivalent resistance of the core is

$$R_{\text{eq}} = (1/R_B + 1/R_D)^{-1} = (1/8.125 + 1/2.243)^{-1} = 1.758 \text{ K/W}$$

and the total unit resistance is

$$R_{\text{tot},1} = R_A + R_{\text{eq}} + R_C = 1.854 \text{ K/W}.$$

With 10 such units in parallel, the total wall resistance is

$$R_{\text{tot}} = (10 \times 1/R_{\text{tot},1})^{-1} = 0.1854 \text{ K/W}.$$

<

**COMMENTS:** If surfaces parallel to the heat flow direction are assumed adiabatic, the thermal circuit and the value of  $R_{\text{tot}}$  will differ.

### PROBLEM 3.16

**KNOWN:** Dimensions and materials associated with a composite wall (2.5 m × 6.5 m, 10 studs each 2.5 m high).

**FIND:** Wall thermal resistance.

**SCHEMATIC:**

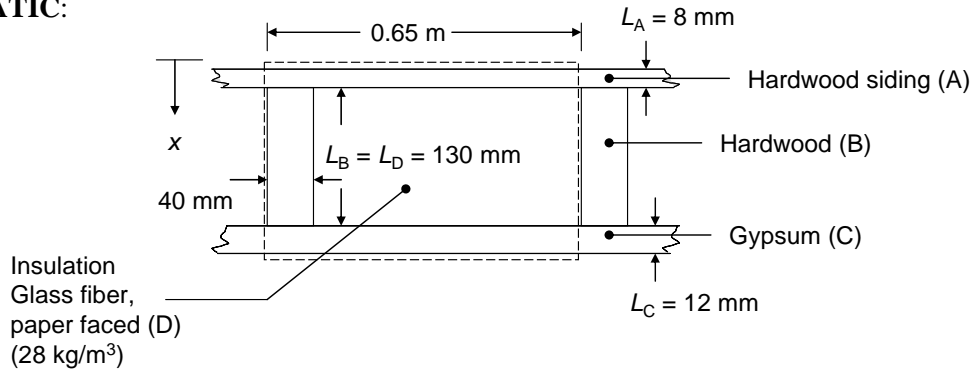

**ASSUMPTIONS:** (1) Steady-state, one-dimensional conditions, (2) Planes parallel to  $x$  are adiabatic, (3) Constant properties, (4) Negligible contact resistance.

**PROPERTIES:** Table A-3 ( $T \approx 300$  K): Hardwood siding,  $k_A = 0.094$  W/m·K; Hardwood,  $k_B = 0.16$  W/m·K; Gypsum,  $k_C = 0.17$  W/m·K; Insulation (glass fiber paper faced, 28 kg/m<sup>3</sup>),  $k_D = 0.038$  W/m·K.

**ANALYSIS:** Using the adiabatic surface assumption, the thermal circuit associated with a single unit (enclosed by dashed lines) of the wall is as shown to the right. The various resistances are

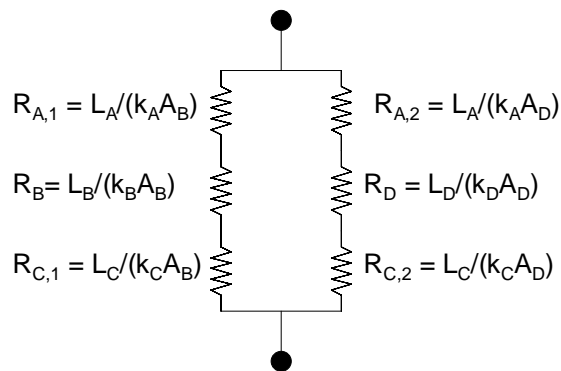

$$R_{A,1} = (L_A/k_A A_B) = \frac{0.008 \text{ m}}{0.094 \text{ W/m} \cdot \text{K} (0.04 \text{ m} \times 2.5 \text{ m})} = 0.8511 \text{ K/W}$$

$$R_B = (L_B/k_B A_B) = \frac{0.13 \text{ m}}{0.16 \text{ W/m} \cdot \text{K} (0.04 \text{ m} \times 2.5 \text{ m})} = 8.125 \text{ K/W}$$

$$R_{C,1} = (L_C/k_C A_B) = \frac{0.012 \text{ m}}{0.17 \text{ W/m} \cdot \text{K} (0.04 \text{ m} \times 2.5 \text{ m})} = 0.7059 \text{ K/W}$$

$$R_{A,2} = (L_A/k_A A_D) = \frac{0.008 \text{ m}}{0.094 \text{ W/m} \cdot \text{K} (0.61 \text{ m} \times 2.5 \text{ m})} = 0.0558 \text{ K/W}$$

$$R_D = (L_D/k_D A_D) = \frac{0.13 \text{ m}}{0.038 \text{ W/m} \cdot \text{K} (0.61 \text{ m} \times 2.5 \text{ m})} = 2.243 \text{ K/W}$$

$$R_{C,2} = (L_C/k_C A_D) = \frac{0.012 \text{ m}}{0.17 \text{ W/m} \cdot \text{K} (0.61 \text{ m} \times 2.5 \text{ m})} = 0.0463 \text{ K/W}$$

Continued...

### PROBLEM 3.16 (Cont.)

The total unit resistance is

$$\begin{aligned} R_{\text{tot},1} &= \left( \frac{1}{R_{A,1} + R_B + R_{C,1}} + \frac{1}{R_{A,2} + R_D + R_{C,2}} \right)^{-1} = \left( \frac{1}{0.8511 + 8.125 + 0.7059} + \frac{1}{0.0558 + 2.243 + 0.0463} \right)^{-1} \\ &= 1.888 \text{ K/W} \end{aligned}$$

With 10 such units in parallel, the total wall resistance is  $R_{\text{tot}} = (10 \times 1/R_{\text{tot},1})^{-1} = 0.1888 \text{ K/W}$ . <

**COMMENTS:** (1) Contact resistance will increase the overall wall resistance relative to that calculated here. (2) The total wall resistance assuming isothermal surfaces normal to the  $x$  direction is  $0.1854 \text{ K/W}$ , which is within 2 % of the value found in this solution.

### PROBLEM 3.17

**KNOWN:** Thickness and thermal conductivity of oven wall insulation. Exterior air temperature and convection heat transfer coefficient. Interior air temperature and convection heat transfer coefficients under free and forced convection conditions.

**FIND:** Heat flux through oven walls under free and forced convection conditions. Impact of forced convection on heat loss. Effect of radiation.

**SCHEMATIC:**

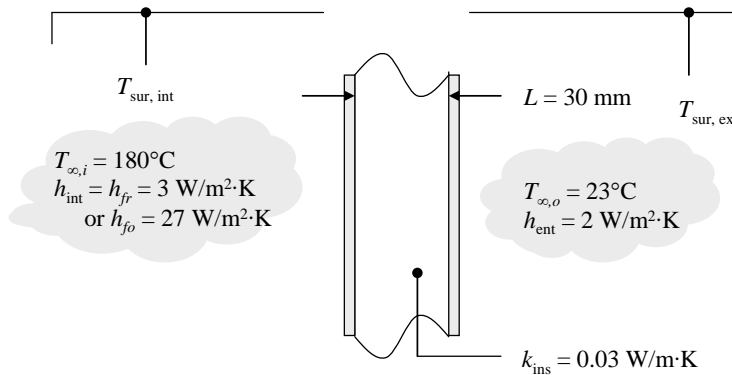

**ASSUMPTIONS:** (1) Steady-state conditions, (2) One-dimensional conduction through walls, (3) Thermal resistance of sheet metal layers is negligible, (4) Interior and exterior radiation is to large surroundings at the air temperatures, (5) Emissivity is approximately 1.0, (6) Negligible contact resistances.

**ANALYSIS:** Neglecting radiation, the heat flux through the oven wall can be calculated from Equations 3.11 and 3.12 on a per unit area basis.

$$q_x'' = (T_{\infty, \text{int}} - T_{\infty, \text{ext}}) / R_{\text{tot}}''$$

where

$$R_{\text{tot}}'' = \frac{1}{h_{\text{int}}} + \frac{L}{k_{\text{ins}}} + \frac{1}{h_{\text{ext}}}$$

When forced convection is disabled inside the oven, we have  $h_{\text{int}} = h_{fr}$  and

$$\begin{aligned} R_{\text{tot}}'' &= \frac{1}{h_{\text{int}}} + \frac{L}{k_{\text{ins}}} + \frac{1}{h_{\text{ext}}} = \frac{1}{3 \text{ W/m}^2 \cdot \text{K}} + \frac{0.03 \text{ m}}{0.03 \text{ W/m} \cdot \text{K}} + \frac{1}{2 \text{ W/m}^2 \cdot \text{K}} \\ &= 0.33 \text{ m}^2 \cdot \text{K/W} + 1 \text{ m}^2 \cdot \text{K/W} + 0.5 \text{ m}^2 \cdot \text{K/W} = 1.83 \text{ m}^2 \cdot \text{K/W} \end{aligned}$$

Therefore

$$q_x'' = (T_{\infty, \text{int}} - T_{\infty, \text{ext}}) / R_{\text{tot}}'' = (180^\circ\text{C} - 23^\circ\text{C}) / 1.83 \text{ m}^2 \cdot \text{K/W} = 85.6 \text{ W/m}^2 \quad <$$

When forced convection is activated inside the oven, we have  $h_{\text{int}} = h_{fo}$  and

Continued...

### PROBLEM 3.17 (Cont.)

$$R''_{\text{tot}} = \frac{1}{h_{\text{int}}} + \frac{L}{k_{\text{ins}}} + \frac{1}{h_{\text{ext}}} = \frac{1}{27 \text{ W/m}^2 \cdot \text{K}} + \frac{0.03 \text{ m}}{0.03 \text{ W/m} \cdot \text{K}} + \frac{1}{2 \text{ W/m}^2 \cdot \text{K}}$$
$$= 0.037 \text{ m}^2 \cdot \text{K/W} + 1 \text{ m}^2 \cdot \text{K/W} + 0.5 \text{ m}^2 \cdot \text{K/W} = 1.537 \text{ m}^2 \cdot \text{K/W}$$

and

$$q''_x = (T_{\infty, \text{int}} - T_{\infty, \text{ext}}) / R''_{\text{tot}} = (180^\circ\text{C} - 23^\circ\text{C}) / 1.537 \text{ m}^2 \cdot \text{K/W} = 102 \text{ W/m}^2 \quad \leftarrow$$

Operation in forced convection mode increases oven heat loss by around 19%. Although  $h_{\text{int}}$  increases by a factor of 9, other thermal resistances tend to dominate the total thermal resistance. ←

Radiation at both the inner and outer oven surfaces can be accounted for by combining convection and radiation heat transfer in parallel. This results in a total heat transfer coefficient at each surface that is the sum of the convection and radiation heat transfer coefficients, see Example 3.1. Therefore, the total thermal resistance can be expressed as

$$R''_{\text{tot}} = \frac{1}{h_{\text{int}} + h_{r, \text{int}}} + \frac{L}{k_{\text{ins}}} + \frac{1}{h_{\text{ext}} + h_{r, \text{ext}}}$$

The radiation heat transfer coefficient is given by Equation 1.9 and can be approximated as

$$h_r \approx 4\varepsilon\sigma\bar{T}^3$$

where  $\bar{T} = (T_s + T_{\text{sur}}) / 2$ . We do not know the oven surface temperatures and will approximate both surface temperatures as the average of the interior and exterior air temperatures,  $T_s = (T_{\infty, \text{int}} + T_{\infty, \text{ext}}) / 2 = 101.5^\circ\text{C} \approx 375 \text{ K}$ . Thus,  $\bar{T}_{\text{int}} = 414 \text{ K}$  and  $\bar{T}_{\text{ext}} = 335.5 \text{ K}$ . Assuming the emissivity of both surfaces is  $\varepsilon \approx 1$ , we find  $h_{r, \text{int}} \approx 16 \text{ W/m}^2 \cdot \text{K}$  and  $h_{r, \text{ext}} \approx 8.6 \text{ W/m}^2 \cdot \text{K}$ . Thus, under free convection conditions,

$$R''_{\text{tot}} = \frac{1}{(3+16) \text{ W/m}^2 \cdot \text{K}} + 1 \text{ m}^2 \cdot \text{K/W} + \frac{1}{(2+8.6) \text{ W/m}^2 \cdot \text{K}}$$
$$= (0.053 + 1 + 0.094) \text{ m}^2 \cdot \text{K/W} = 1.17 \text{ m}^2 \cdot \text{K/W}$$

and under forced convection conditions,

$$R''_{\text{tot}} = \frac{1}{(27+16) \text{ W/m}^2 \cdot \text{K}} + 1 \text{ m}^2 \cdot \text{K/W} + 0.094 \text{ m}^2 \cdot \text{K/W}$$
$$= (0.023 + 1 + 0.094) \text{ m}^2 \cdot \text{K/W} = 1.12 \text{ m}^2 \cdot \text{K/W}$$

When radiation is accounted for, the internal and external heat transfer resistances become small compared to the thermal resistance of the insulation, and there is little difference between the total thermal resistance with or without forced convection inside the oven. ←

**COMMENTS:** The radiation heat flux can be calculated more accurately by solving for the oven interior and exterior surface temperatures, however without knowledge of the surface emissivity there is no reason to be so precise.

### PROBLEM 3.18

**KNOWN:** Thicknesses of three materials which form a composite wall and thermal conductivities of two of the materials. Inner and outer surface temperatures of the composite; also, temperature and convection coefficient associated with adjoining gas.

**FIND:** Value of unknown thermal conductivity,  $k_B$ .

**SCHEMATIC:**

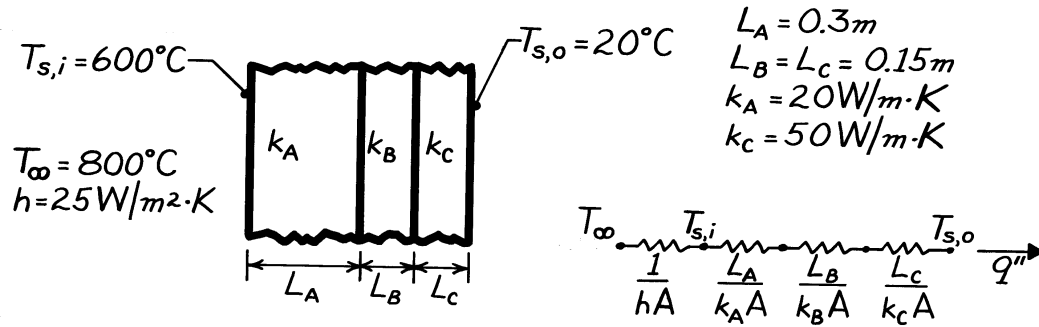

**ASSUMPTIONS:** (1) Steady-state conditions, (2) One-dimensional conduction, (3) Constant properties, (4) Negligible contact resistance, (5) Negligible radiation effects.

**ANALYSIS:** Referring to the thermal circuit, the heat flux may be expressed as

$$q'' = \frac{T_{s,i} - T_{s,o}}{\frac{L_A}{k_A} + \frac{L_B}{k_B} + \frac{L_C}{k_C}} = \frac{(600 - 20)^{\circ}\text{C}}{\frac{0.3\text{ m}}{20\text{ W/m}\cdot\text{K}} + \frac{0.15\text{ m}}{k_B} + \frac{0.15\text{ m}}{50\text{ W/m}\cdot\text{K}}}$$

$$q'' = \frac{580}{0.018 + 0.15/k_B} \text{ W/m}^2. \quad (1)$$

The heat flux may be obtained from

$$q'' = h(T_{\infty} - T_{s,i}) = 25\text{ W/m}^2\cdot\text{K}(800 - 600)^{\circ}\text{C} \quad (2)$$

$$q'' = 5000\text{ W/m}^2.$$

Substituting for the heat flux from Eq. (2) into Eq. (1), find

$$\frac{0.15}{k_B} = \frac{580}{q''} - 0.018 = \frac{580}{5000} - 0.018 = 0.098$$

$$k_B = 1.53\text{ W/m}\cdot\text{K}. \quad <$$

**COMMENTS:** Radiation effects are likely to have a significant influence on the net heat flux at the inner surface of the oven.



### PROBLEM 3.19

**KNOWN:** Drying oven wall having material with known thermal conductivity sandwiched between thin metal sheets. Radiation and convection conditions prescribed on inner surface; convection conditions on outer surface.

**FIND:** (a) Thermal circuit representing wall and processes and (b) Insulation thickness required to maintain outer wall surface at  $T_o = 40^\circ\text{C}$ .

**SCHEMATIC:**

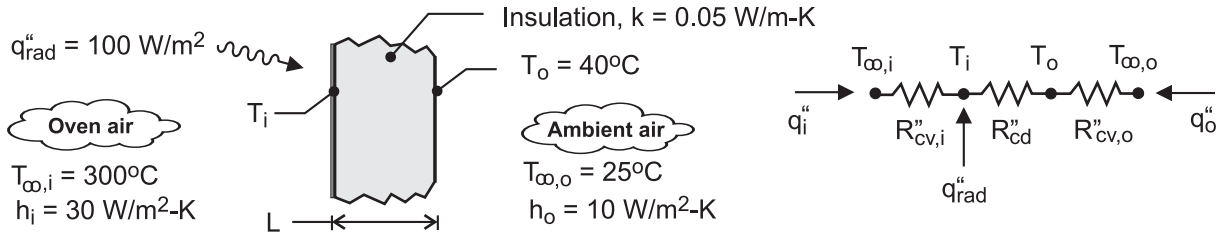

**ASSUMPTIONS:** (1) Steady-state conditions, (2) One-dimensional conduction in wall, (3) Thermal resistance of metal sheets negligible, (4) Negligible contact resistance.

**ANALYSIS:** (a) The thermal circuit is shown above. Note labels for the temperatures, thermal resistances and the relevant heat fluxes.

(b) Perform energy balances on the i- and o- nodes finding

$$\frac{T_{\infty,i} - T_i}{R''_{cv,i}} + \frac{T_o - T_i}{R''_{cd}} + q''_{rad} = 0 \quad (1)$$

$$\frac{T_i - T_o}{R''_{cd}} + \frac{T_{\infty,o} - T_o}{R''_{cv,o}} = 0 \quad (2)$$

where the thermal resistances are

$$R''_{cv,i} = 1/h_i = 0.0333 \text{ m}^2 \cdot \text{K} / \text{W} \quad (3)$$

$$R''_{cd} = L/k = L/0.05 \text{ m}^2 \cdot \text{K} / \text{W} \quad (4)$$

$$R''_{cv,o} = 1/h_o = 0.100 \text{ m}^2 \cdot \text{K} / \text{W} \quad (5)$$

Substituting numerical values, and solving Eqs. (1) and (2) simultaneously, find

$$L = 86 \text{ mm} \quad <$$

**COMMENTS:** (1) The temperature at the inner surface can be found from an energy balance on the i-node using the value found for L.

$$\frac{T_{\infty,i} - T_i}{R''_{cv,i}} + \frac{T_{\infty,o} - T_i}{R''_{cd} + R''_{cv,i}} + q''_{rad} = 0 \quad T_i = 298.3^\circ\text{C}$$

It follows that  $T_i$  is close to  $T_{\infty,i}$  since the wall represents the dominant resistance of the system.

(2) Verify that  $q_i'' = 50 \text{ W} / \text{m}^2$  and  $q_o'' = -150 \text{ W} / \text{m}^2$ . Is the overall energy balance on the system satisfied?

### PROBLEM 3.20

**KNOWN:** Window surface area and thickness, inside and outside heat transfer coefficients, outside and passenger compartment temperatures.

**FIND:** Heat loss through the windows for high and low inside heat transfer coefficients.

**SCHEMATIC:**

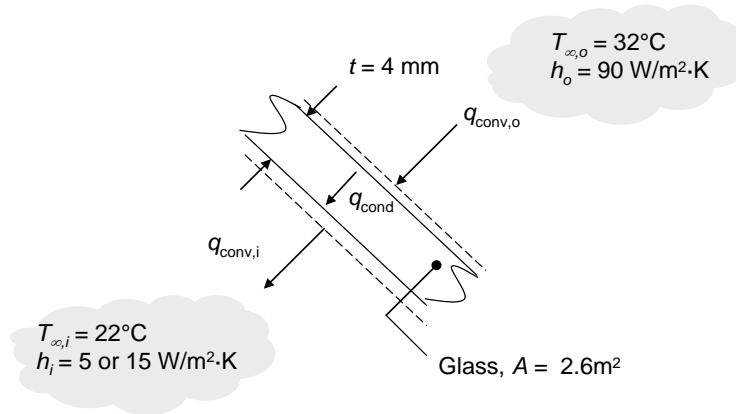

**ASSUMPTIONS:** (1) Steady-state, one-dimensional conduction. (2) Constant properties. (3) Negligible radiation.

**PROPERTIES:** Table A.3, glass ( $T = 300 \text{ K}$ ):  $k = 1.4 \text{ W/m}\cdot\text{K}$ .

**ANALYSIS:** The thermal circuit is

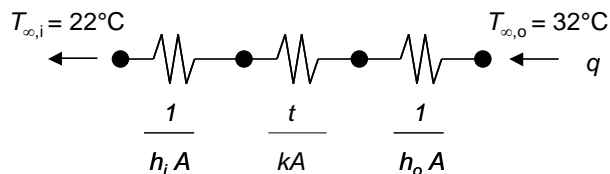

from which the heat transfer rate through the windows for  $h_i = 15 \text{ W/m}^2\cdot\text{K}$  is

$$\begin{aligned}
 q &= \frac{T_{\infty,o} - T_{\infty,i}}{\left( \frac{1}{h_i A} + \frac{t}{kA} + \frac{1}{h_o A} \right)} \\
 &= \frac{(32 - 22)^\circ\text{C}}{\left( \frac{1}{15 \text{ W/m}^2 \cdot \text{K} \times 2.6 \text{ m}^2} + \frac{4 \times 10^{-3} \text{ m}}{1.4 \text{ W/m} \cdot \text{K} \times 2.6 \text{ m}^2} + \frac{1}{90 \text{ W/m}^2 \cdot \text{K} \times 2.6 \text{ m}^2} \right)} \\
 &= 333 \text{ W}
 \end{aligned}$$

<

Repeating the calculation for  $h_i = 5 \text{ W/m}^2\cdot\text{K}$  yields  $q = 121 \text{ W}$

<

Continued...

### PROBLEM 3.20 (Cont.)

**COMMENTS:** (1) Assuming an air conditioner COP of 3, controlling the airflow in the passenger cabin to reduce the interior convection heat transfer coefficient will reduce the power consumed by the air conditioner by  $\Delta P = (333 \text{ W} - 121 \text{ W})/3 = 71 \text{ W}$ . (2) A smaller air conditioner can be utilized with the lower interior heat transfer coefficient. This will both (a) reduce the cost of the air conditioner and (b) reduce the amount of refrigerant in the air conditioning unit. Reduction in the amount of refrigerant used will also reduce the level of refrigerant that might leak from the system, potentially reducing greenhouse gas emissions. (3) The individual resistance values are  $R_{conv,i} = 0.026 \text{ K/W}$ ,  $R_{cond} = 0.0011 \text{ K/W}$ , and  $R_{conv,o} = 0.0043 \text{ K/W}$  for  $h_i = 15 \text{ W/m}^2\cdot\text{K}$ .

### PROBLEM 3.21

**KNOWN:** Conditions associated with maintaining heated and cooled conditions within a refrigerator compartment.

**FIND:** Coefficient of performance (COP).

**SCHEMATIC:**

$$\begin{aligned} \longrightarrow & T_{\infty} = 20 \text{ }^{\circ}\text{C} \\ \longrightarrow & h = 50 \text{ W/m}^2 \cdot \text{K} \end{aligned}$$

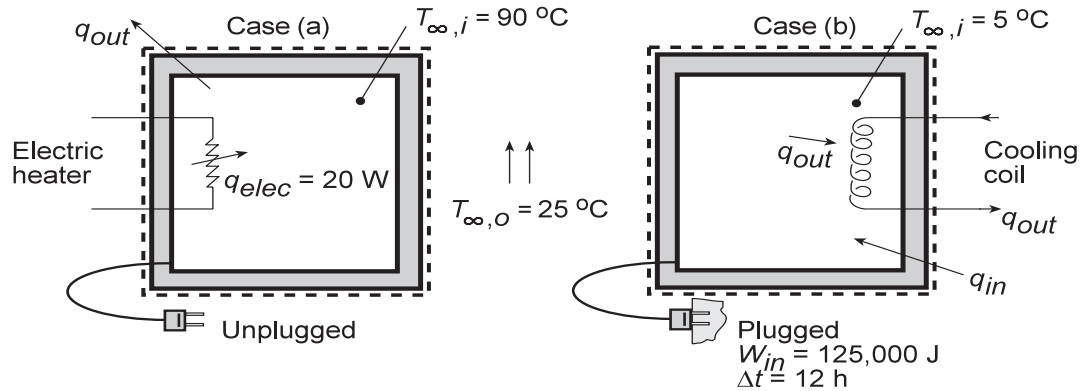

**ASSUMPTIONS:** (1) Steady-state operating conditions, (2) Negligible radiation, (3) Compartment completely sealed from ambient air.

**ANALYSIS:** The Case (a) experiment is performed to determine the overall thermal resistance to heat transfer between the interior of the refrigerator and the ambient air. Applying an energy balance to a control surface about the refrigerator, it follows from Eq. 1.12b that, at any instant,

$$\dot{E}_g - \dot{E}_{out} = 0$$

Hence,

$$q_{elec} - q_{out} = 0$$

where  $q_{out} = (T_{\infty,i} - T_{\infty,o})/R_t$ . It follows that

$$R_t = \frac{T_{\infty,i} - T_{\infty,o}}{q_{elec}} = \frac{(90 - 25)^{\circ}\text{C}}{20 \text{ W}} = 3.25^{\circ}\text{C/W}$$

For Case (b), heat transfer from the ambient air to the compartment (the heat load) is balanced by heat transfer to the refrigerant ( $q_{in} = q_{out}$ ). Hence, the thermal energy transferred from the refrigerator over the 12 hour period is

$$Q_{out} = q_{out} \Delta t = q_{in} \Delta t = \frac{T_{\infty,i} - T_{\infty,o}}{R_t} \Delta t$$

$$Q_{out} = \frac{(25 - 5)^{\circ}\text{C}}{3.25^{\circ}\text{C/W}} (12 \text{ h} \times 3600 \text{ s/h}) = 266,000 \text{ J}$$

The coefficient of performance (COP) is therefore

$$\text{COP} = \frac{Q_{out}}{W_{in}} = \frac{266,000}{125,000} = 2.13$$

**COMMENTS:** The ideal (Carnot) COP is

$$\text{COP}_{ideal} = \frac{T_c}{T_h - T_c} = \frac{278 \text{ K}}{(298 - 278) \text{ K}} = 13.9$$

and the system is operating well below its peak possible performance.

### PROBLEM 3.22

**KNOWN:** Total floor space and vertical distance between floors for a square, flat roof building.

**FIND:** (a) Expression for width of building which minimizes heat loss, (b) Width and number of floors which minimize heat loss for a prescribed floor space and distance between floors. Corresponding heat loss, percent heat loss reduction from 2 floors.

**SCHEMATIC:**

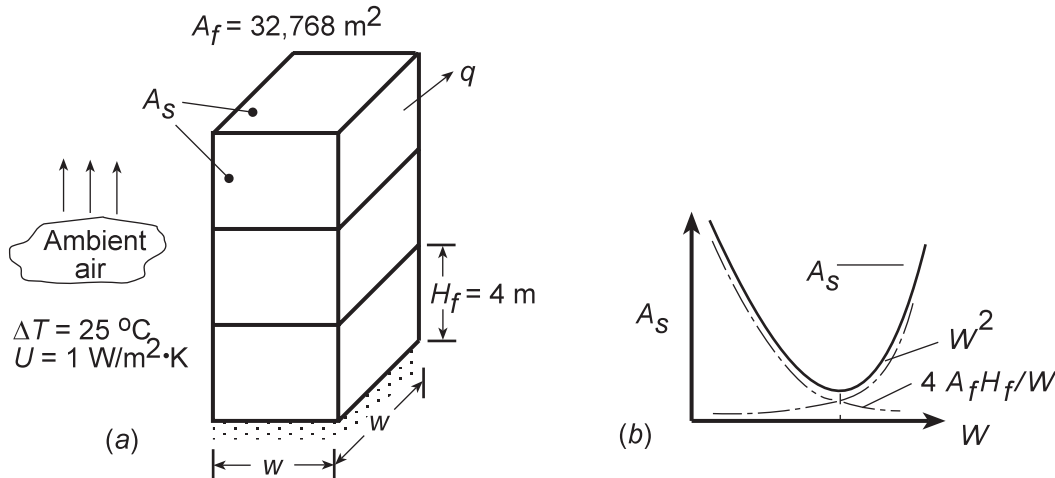

**ASSUMPTIONS:** Negligible heat loss to ground.

**ANALYSIS:** (a) To minimize the heat loss  $q$ , the exterior surface area,  $A_s$ , must be minimized. From Fig. (a)

$$A_s = W^2 + 4WH = W^2 + 4WN_fH_f$$

where

$$N_f = A_f / W^2$$

Hence,

$$A_s = W^2 + 4WA_f H_f / W^2 = W^2 + 4A_f H_f / W$$

The optimum value of  $W$  corresponds to

$$\frac{dA_s}{dW} = 2W - \frac{4A_f H_f}{W^2} = 0$$

or

$$W_{op} = (2A_f H_f)^{1/3} \quad <$$

The competing effects of  $W$  on the areas of the roof and sidewalls, and hence the basis for an optimum, is shown schematically in Fig. (b).

(b) For  $A_f = 32,768 \text{ m}^2$  and  $H_f = 4 \text{ m}$ ,

$$W_{op} = \left( 2 \times 32,768 \text{ m}^2 \times 4 \text{ m} \right)^{1/3} = 64 \text{ m} \quad <$$

Continued ...

### PROBLEM 3.22 (Cont.)

Hence,

$$N_f = \frac{A_f}{W^2} = \frac{32,768 \text{ m}^2}{(64 \text{ m})^2} = 8 \quad <$$

and

$$q = UA_s \Delta T = 1 \text{ W/m}^2 \cdot \text{K} \left[ (64 \text{ m})^2 + \frac{4 \times 32,768 \text{ m}^2 \times 4 \text{ m}}{64 \text{ m}} \right] 25^\circ \text{C} = 307,200 \text{ W} \quad <$$

For  $N_f = 2$ ,

$$W = (A_f/N_f)^{1/2} = (32,768 \text{ m}^2/2)^{1/2} = 128 \text{ m}$$
$$q = 1 \text{ W/m}^2 \cdot \text{K} \left[ (128 \text{ m})^2 + \frac{4 \times 32,768 \text{ m}^2 \times 4 \text{ m}}{128 \text{ m}} \right] 25^\circ \text{C} = 512,000 \text{ W}$$

$$\% \text{ reduction in } q = (512,000 - 307,200)/512,000 = 40\% \quad <$$

**COMMENTS:** Even the minimum heat loss is excessive and could be reduced by reducing  $U$ .

### PROBLEM 3.23

**KNOWN:** Dimensions and temperature of a canister containing a solid oxide fuel cell. Surroundings and ambient temperature.

**FIND:** (a) Required insulation thickness to keep the equivalent blackbody temperature below 305 K, (b) Canister surface temperature for four cases, (c) Heat flux through the cylindrical walls for four cases.

**SCHEMATIC:**

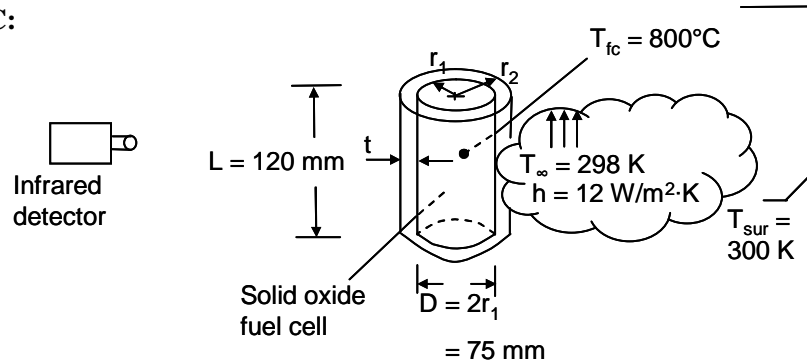

**ASSUMPTIONS:** (1) Steady-state conditions, (2) Constant properties, (3) One-dimensional heat transfer, (4) Large surroundings.

**ANALYSIS:** The maximum allowable surface temperature may be found by relating the actual and inferred surface temperatures through the relation

$$E_s = E_b = \epsilon_s \sigma T_s^4 = \sigma T_b^4 \quad \text{or} \quad T_s = (T_b^4 / \epsilon_s)^{1/4} \quad (1)$$

The thermal circuit is

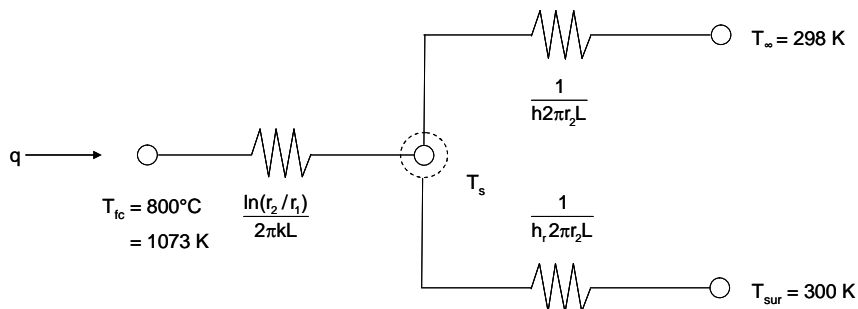

where, from Eq. 1.9,

$$h_r = \epsilon_s \sigma (T_s + T_{sur})(T_s^2 + T_{sur}^2) \quad (2)$$

Summing currents at the  $T_s$  node yields

Continued...

**PROBLEM 3.23 (Cont.)**

$$\frac{T_{fc} - T_s}{\left[ \frac{\ln(r_2 / r_1)}{2\pi k L} \right]} = \frac{T_s - T_\infty}{\left[ \frac{1}{h_2 2\pi r_2 L} \right]} + \frac{T_s - T_{sur}}{\left[ \frac{1}{h_1 2\pi r_2 L} \right]} \quad (3)$$

where

$$q = \frac{T_{fc} - T_s}{\left[ \frac{\ln(r_2 / r_1)}{2\pi / L} \right]} L \quad (4)$$

Noting that the insulation thickness is  $t = r_2 - r_1$ , solving Eqs. (2) and (3) simultaneously, and then solving Eq. (4) yields the following results.

$\epsilon_s$	$k$ (W/m·K)	$t$ (m)	$T_s$ (K)	$q$ (W)
0.08	0.09	0.0875	573.5	135
0.9	0.09	0.963	313.1	33.75
0.08	0.006	0.0008	573.5	108.4
0.9	0.006	0.015	313.1	10.2

**COMMENTS:** (1) Use of the low emissivity surface allows surface temperatures to be high without the fuel cell being detected. (2) The high surface temperature is not safe to the touch. (3) The low thermal conductivity of the aerogel allows the use of a small insulation thickness relative to the calcium silicate. (4) Small heat losses and low surface temperatures are desired. The  $\epsilon_s = 0.9$ ,  $k = 0.006$  case offers the best performance, and the surface need not be kept in a polished condition to avoid detection.



### PROBLEM 3.24

**KNOWN:** Representative dimensions and thermal conductivities for the layers of fire-fighter's protective clothing, a turnout coat.

**FIND:** (a) Thermal circuit representing the turnout coat; tabulate thermal resistances of the layers and processes; and (b) For a prescribed radiant heat flux on the fire-side surface and temperature of  $T_i = 60^\circ\text{C}$  at the inner surface, calculate the fire-side surface temperature,  $T_o$ .

**SCHEMATIC:**

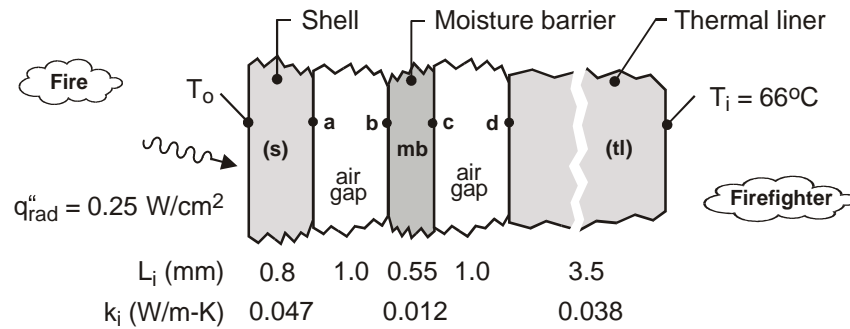

**ASSUMPTIONS:** (1) Steady-state conditions, (2) One-dimensional conduction through the layers, (3) Heat is transferred by conduction and radiation exchange across the stagnant air gaps, (3) Constant properties.

**PROPERTIES:** Table A-4, Air (470 K, 1 atm):  $k_{ab} = k_{cd} = 0.0387$  W/m-K.

**ANALYSIS:** (a) The thermal circuit is shown with labels for the temperatures and thermal resistances.

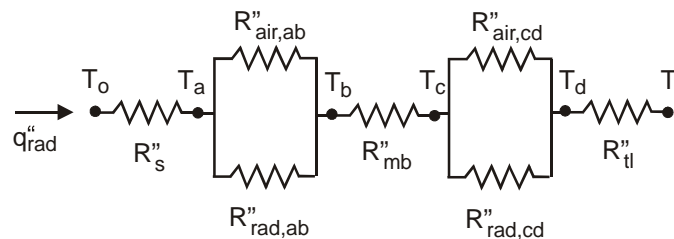

The conduction thermal resistances have the form  $R''_{cd} = L/k$  while the radiation thermal resistances across the air gaps have the form

$$R''_{\text{rad}} = \frac{1}{h_{\text{rad}}} = \frac{1}{4\sigma T_{\text{avg}}^3}$$

The linearized radiation coefficient follows from Eqs. 1.8 and 1.9 with  $\varepsilon = 1$  where  $T_{\text{avg}}$  represents the average temperature of the surfaces comprising the gap

$$h_{\text{rad}} = \sigma (T_1 + T_2) (T_1^2 + T_2^2) \approx 4\sigma T_{\text{avg}}^3$$

For the radiation thermal resistances tabulated below, we used  $T_{\text{avg}} = 470$  K.

Continued ...

**PROBLEM 3.24 (Cont.)**

	Shell (s)	Air gap (a-b)	Barrier (mb)	Air gap (c-d)	Liner (tl)	Total (tot)
$R''_{cd} \left( m^2 \cdot K / W \right)$	0.01702	0.0222	0.04583	0.0222	0.0921	--
$R''_{rad} \left( m^2 \cdot K / W \right)$	--	0.04246	--	0.04246	--	--
$R''_{gap} \left( m^2 \cdot K / W \right)$	--	0.0146	--	0.0146	--	--
$R''_{total}$	--	--	--	--	--	0.1842

From the thermal circuit, the resistance across the gap for the conduction and radiation processes is

$$\frac{1}{R''_{gap}} = \frac{1}{R''_{cd}} + \frac{1}{R''_{rad}}$$

and the total thermal resistance of the turn coat is

$$R''_{tot} = R''_{cd,s} + R''_{gap,a-b} + R''_{cd,mb} + R''_{gap,c-d} + R''_{cd,tl}$$

(b) If the heat flux through the coat is  $0.25 \text{ W/cm}^2$ , the fire-side surface temperature  $T_o$  can be calculated from the rate equation written in terms of the overall thermal resistance.

$$q'' = (T_o - T_i) / R''_{tot}$$

$$T_o = 66^\circ\text{C} + 0.25 \text{ W/cm}^2 \times \left( 10^2 \text{ cm/m} \right)^2 \times 0.1842 \text{ m}^2 \cdot \text{K/W}$$

$$T_o = 526^\circ\text{C}$$

<

**COMMENTS:** (1) From the tabulated results, note that the thermal resistance of the moisture barrier (mb) is nearly 3 times larger than that for the shell or air gap layers. The thermal liner has the greatest thermal resistance. (2) The air gap conduction and radiation resistances were calculated based upon the average temperature of 570 K. This value was determined by setting  $T_{avg} = (T_o + T_i)/2$  and solving the equation set using *IHT* with  $k_{air} = k_{air}(T_{avg})$ .

### PROBLEM 3.25

**KNOWN:** Values of three individual thermal conduction resistances.

**FIND:** Which conduction resistance should be reduced by half in order to most effectively reduce the total conduction resistance.

**SCHEMATIC:**

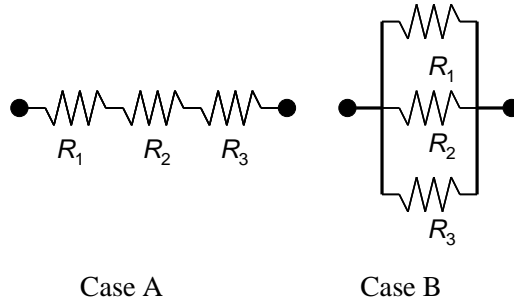

**ASSUMPTIONS:** (1) Steady-state, one-dimensional conduction, (2) Constant properties.

**ANALYSIS:** We begin with the series resistance network, Case A. The total thermal resistances associated with the nominal values of the individual thermal resistances, as well as for situations where the nominal resistance values are reduced by 50%, are presented in the table below.

<u>Case A</u>	$R_1$ (K/W)	$R_2$ (K/W)	$R_3$ (K/W)	$R_{tot}$ (K/W)	
Nominal	1	2	4	7	
	0.5	2	4	6.5	
	1	1	4	6	
	1	2	2	5	<

The reduction in the total thermal resistance is greatest if the value of  $R_3$  is reduced from 4 to 2 K/W.

<u>Case B</u>	$R_1$ (K/W)	$R_2$ (K/W)	$R_3$ (K/W)	$R_{tot}$ (K/W)	
Nominal	1	2	4	0.5714	
	0.5	2	4	0.3636	<
	1	1	4	0.4444	
	1	2	2	0.5000	

For the resistances in parallel, the reduction in the total thermal resistance is greatest if the value of  $R_1$  is reduced from 1 to 0.5 K/W.

Hence, it is not possible to make a recommendation to the chief engineer as to which resistance should be targeted for reduction without first knowing how the resistances are placed within the resistance network.

**COMMENTS:** A common and serious mistake is to assume that the largest thermal resistance dominates the thermal resistance network. Although this is sometimes the case, careful analysis will often reveal quicker, and less expensive alternatives to either reduce or increase the total thermal resistance.

### PROBLEM 3.26

**KNOWN:** Materials and dimensions of a composite wall separating a combustion gas from a liquid coolant.

**FIND:** (a) Heat loss per unit area, and (b) Temperature distribution.

**SCHEMATIC:**

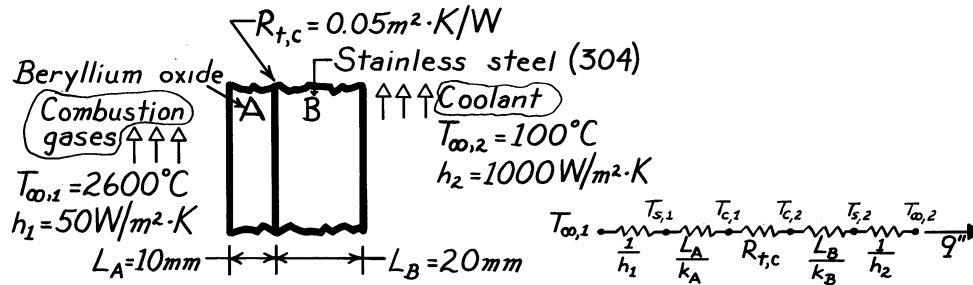

**ASSUMPTIONS:** (1) One-dimensional heat transfer, (2) Steady-state conditions, (3) Constant properties, (4) Negligible radiation effects.

**PROPERTIES:** Table A-1, St. St. (304) ( $\bar{T} \approx 1000\text{K}$ ):  $k = 25.4 \text{ W/m}\cdot\text{K}$ ; Table A-2, Beryllium Oxide ( $T \approx 1500\text{K}$ ):  $k = 21.5 \text{ W/m}\cdot\text{K}$ .

**ANALYSIS:** (a) The desired heat flux may be expressed as

$$q'' = \frac{T_{\infty,1} - T_{\infty,2}}{\frac{1}{h_1} + \frac{L_A}{k_A} + R_{t,c} + \frac{L_B}{k_B} + \frac{1}{h_2}} = \frac{(2600 - 100)^\circ\text{C}}{\left[ \frac{1}{50} + \frac{0.01}{21.5} + 0.05 + \frac{0.02}{25.4} + \frac{1}{1000} \right] \frac{\text{m}^2\cdot\text{K}}{\text{W}}}$$

$$q'' = 34,600 \text{ W/m}^2.$$

(b) The composite surface temperatures may be obtained by applying appropriate rate equations. From the fact that  $q'' = h_1 (T_{\infty,1} - T_{s,1})$ , it follows that

$$T_{s,1} = T_{\infty,1} - \frac{q''}{h_1} = 2600^\circ\text{C} - \frac{34,600 \text{ W/m}^2}{50 \text{ W/m}^2\cdot\text{K}} = 1908^\circ\text{C}.$$

With  $q'' = (k_A / L_A)(T_{s,1} - T_{c,1})$ , it also follows that

$$T_{c,1} = T_{s,1} - \frac{L_A q''}{k_A} = 1908^\circ\text{C} - \frac{0.01\text{m} \times 34,600 \text{ W/m}^2}{21.5 \text{ W/m}\cdot\text{K}} = 1892^\circ\text{C}.$$

Similarly, with  $q'' = (T_{c,1} - T_{c,2}) / R_{t,c}$

$$T_{c,2} = T_{c,1} - R_{t,c} q'' = 1892^\circ\text{C} - 0.05 \frac{\text{m}^2\cdot\text{K}}{\text{W}} \times 34,600 \frac{\text{W}}{\text{m}^2} = 162^\circ\text{C}$$

Continued ...

**PROBLEM 3.26 (Cont.)**

and with  $q'' = (k_B / L_B)(T_{c,2} - T_{s,2})$ ,

$$T_{s,2} = T_{c,2} - \frac{L_B q''}{k_B} = 162^\circ\text{C} - \frac{0.02\text{m} \times 34,600\text{ W/m}^2}{25.4\text{ W/m}\cdot\text{K}} = 134.6^\circ\text{C}.$$

The temperature distribution is therefore of the following form:

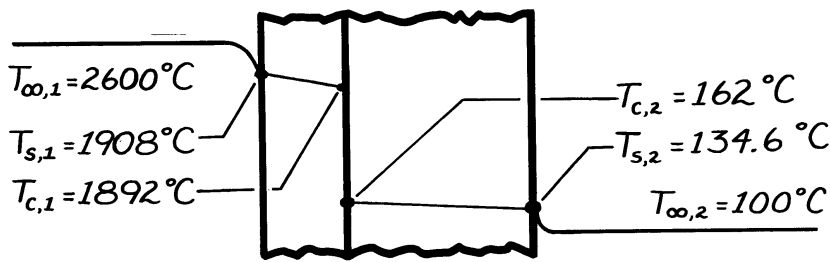

**COMMENTS:** (1) The calculations may be checked by recomputing  $q''$  from

$$q'' = h_2 (T_{s,2} - T_{\infty,2}) = 1000\text{ W/m}^2 \cdot \text{K} (134.6 - 100)^\circ\text{C} = 34,600\text{ W/m}^2$$

(2) The initial *estimates* of the mean material temperatures are in error, particularly for the stainless steel. For improved accuracy the calculations should be repeated using  $k$  values corresponding to  $T \approx 1900^\circ\text{C}$  for the oxide and  $T \approx 115^\circ\text{C}$  for the steel.

(3) The major contributions to the total resistance are made by the combustion gas boundary layer and the contact, where the temperature drops are largest.

### PROBLEM 3.27

**KNOWN:** Operating conditions for a board mounted chip.

**FIND:** (a) Equivalent thermal circuit, (b) Chip temperature, (c) Maximum allowable heat dissipation for dielectric liquid ( $h_o = 1000 \text{ W/m}^2\cdot\text{K}$ ) and air ( $h_o = 100 \text{ W/m}^2\cdot\text{K}$ ). Effect of changes in circuit board temperature and contact resistance.

**SCHEMATIC:**

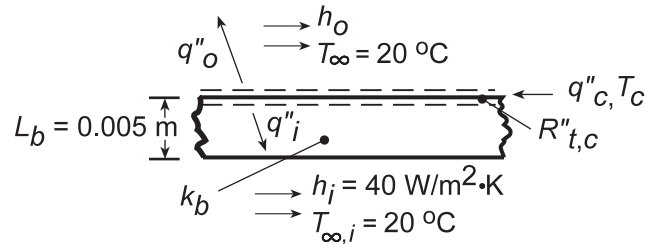

**ASSUMPTIONS:** (1) Steady-state conditions, (2) One-dimensional conduction, (3) Negligible chip thermal resistance, (4) Negligible radiation, (5) Constant properties.

**PROPERTIES:** Table A-2, Aluminum oxide (polycrystalline, 358 K):  $k_b = 32.4 \text{ W/m}\cdot\text{K}$ .

**ANALYSIS:** (a)

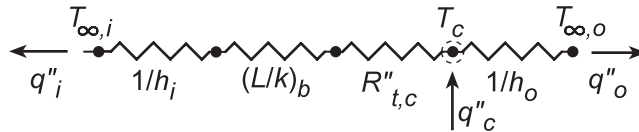

(b) Applying conservation of energy to a control surface about the chip ( $\dot{E}_{in} - \dot{E}_{out} = 0$ ),

$$q''_c - q''_i - q''_o = 0$$

$$q''_c = \frac{T_c - T_{\infty,i}}{1/h_i + (L/k)_b + R''_{t,c}} + \frac{T_c - T_{\infty,o}}{1/h_o}$$

With  $q''_c = 3 \times 10^4 \text{ W/m}^2$ ,  $h_o = 1000 \text{ W/m}^2\cdot\text{K}$ ,  $k_b = 1 \text{ W/m}\cdot\text{K}$  and  $R''_{t,c} = 10^{-4} \text{ m}^2 \cdot \text{K/W}$ ,

$$3 \times 10^4 \text{ W/m}^2 = \frac{T_c - 20^\circ\text{C}}{\left(1/40 + 0.005/1 + 10^{-4}\right) \text{ m}^2 \cdot \text{K/W}} + \frac{T_c - 20^\circ\text{C}}{(1/1000) \text{ m}^2 \cdot \text{K/W}}$$

$$3 \times 10^4 \text{ W/m}^2 = (33.2T_c - 664 + 1000T_c - 20,000) \text{ W/m}^2 \cdot \text{K}$$

$$1033T_c = 50,664$$

$$T_c = 49^\circ\text{C}.$$

(c) For  $T_c = 85^\circ\text{C}$  and  $h_o = 1000 \text{ W/m}^2\cdot\text{K}$ , the foregoing energy balance yields

$$q''_c = 67,160 \text{ W/m}^2$$

with  $q''_o = 65,000 \text{ W/m}^2$  and  $q''_i = 2160 \text{ W/m}^2$ . Replacing the dielectric with air ( $h_o = 100 \text{ W/m}^2\cdot\text{K}$ ), the following results are obtained for different combinations of  $k_b$  and  $R''_{t,c}$ .

Continued...

**PROBLEM 3.27 (Cont.)**

$k_b$ (W/m·K)	$R''_{t,c}$ ( $m^2 \cdot K/W$ )	$q''_i$ (W/m <sup>2</sup> )	$q''_o$ (W/m <sup>2</sup> )	$q''_c$ (W/m <sup>2</sup> )
1	$10^{-4}$	2159	6500	8659
32.4	$10^{-4}$	2574	6500	9074
1	$10^{-5}$	2166	6500	8666
32.4	$10^{-5}$	2583	6500	9083

<

**COMMENTS:** 1. For the conditions of part (b), the total internal resistance is  $0.0301 \text{ m}^2 \cdot \text{K/W}$ , while the outer resistance is  $0.001 \text{ m}^2 \cdot \text{K/W}$ . Hence

$$\frac{q''_o}{q''_i} = \frac{(T_c - T_{\infty,o})/R''_o}{(T_c - T_{\infty,i})/R''_i} = \frac{0.0301}{0.001} = 30.$$

and only approximately 3% of the heat is dissipated through the board.

2. With  $h_o = 100 \text{ W/m}^2 \cdot \text{K}$ , the outer resistance increases to  $0.01 \text{ m}^2 \cdot \text{K/W}$ , in which case  $q''_o/q''_i = R''_i/R''_o = 0.0301/0.01 = 3.1$  and now almost 25% of the heat is dissipated through the board. Hence, although measures to reduce  $R''_i$  would have a negligible effect on  $q''_c$  for the liquid coolant, some improvement may be gained for air-cooled conditions. As shown in the table of part (b), use of an aluminum oxide board increase  $q''_i$  by 19% (from 2159 to 2574  $\text{W/m}^2$ ) by reducing  $R''_i$  from 0.0301 to  $0.0253 \text{ m}^2 \cdot \text{K/W}$ .

Because the initial contact resistance ( $R''_{t,c} = 10^{-4} \text{ m}^2 \cdot \text{K/W}$ ) is already much less than  $R''_i$ , any reduction in its value would have a negligible effect on  $q''_i$ . The largest gain would be realized by increasing  $h_i$ , since the inside convection resistance makes the dominant contribution to the total internal resistance.

### PROBLEM 3.28

**KNOWN:** Thickness, overall temperature difference, and pressure for two stainless steel plates.

**FIND:** (a) Heat flux and (b) Contact plane temperature drop.

**SCHEMATIC:**

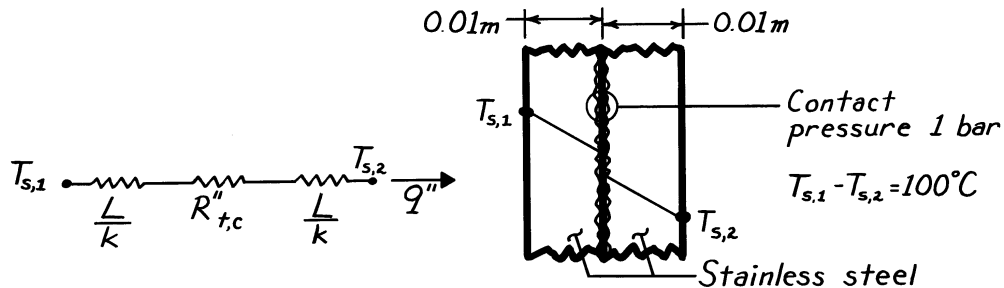

**ASSUMPTIONS:** (1) One-dimensional heat transfer, (2) Steady-state conditions, (3) Constant properties.

**PROPERTIES:** Table A-1, Stainless Steel ( $T \approx 400\text{K}$ ):  $k = 16.6 \text{ W/m}\cdot\text{K}$ .

**ANALYSIS:** (a) With  $R''_{t,c} \approx 15 \times 10^{-4} \text{ m}^2 \cdot \text{K/W}$  from Table 3.1 and

$$\frac{L}{k} = \frac{0.01\text{m}}{16.6 \text{ W/m}\cdot\text{K}} = 6.02 \times 10^{-4} \text{ m}^2 \cdot \text{K/W},$$

it follows that

$$R''_{\text{tot}} = 2(L/k) + R''_{t,c} \approx 27 \times 10^{-4} \text{ m}^2 \cdot \text{K/W};$$

hence

$$q'' = \frac{\Delta T}{R''_{\text{tot}}} = \frac{100^\circ\text{C}}{27 \times 10^{-4} \text{ m}^2 \cdot \text{K/W}} = 3.70 \times 10^4 \text{ W/m}^2. \quad <$$

(b) From the thermal circuit,

$$\frac{\Delta T_c}{T_{s,1} - T_{s,2}} = \frac{R''_{t,c}}{R''_{\text{tot}}} = \frac{15 \times 10^{-4} \text{ m}^2 \cdot \text{K/W}}{27 \times 10^{-4} \text{ m}^2 \cdot \text{K/W}} = 0.556.$$

Hence,

$$\Delta T_c = 0.556(T_{s,1} - T_{s,2}) = 0.556(100^\circ\text{C}) = 55.6^\circ\text{C}. \quad <$$

**COMMENTS:** The contact resistance is significant relative to the conduction resistances. The value of  $R''_{t,c}$  would diminish, however, with increasing pressure. Note that there is considerable uncertainty in the answer since the thermal contact resistance can take on a wide range of values.



### PROBLEM 3.29

**KNOWN:** Temperatures and convection coefficients associated with fluids at inner and outer surfaces of a composite wall. Contact resistance, dimensions, and thermal conductivities associated with wall materials.

**FIND:** (a) Rate of heat transfer through the wall, (b) Temperature distribution.

**SCHEMATIC:**

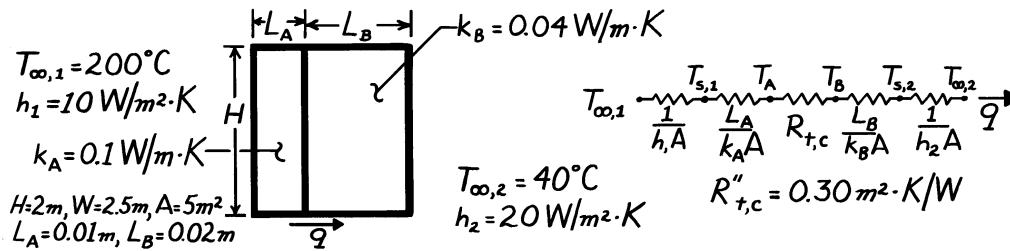

**ASSUMPTIONS:** (1) Steady-state conditions, (2) One-dimensional heat transfer, (3) Negligible radiation, (4) Constant properties.

**ANALYSIS:** (a) Calculate the total resistance to find the heat rate,

$$R_{\text{tot}} = \frac{1}{h_1 A} + \frac{L_A}{k_A A} + R_{t,c} + \frac{L_B}{k_B A} + \frac{1}{h_2 A}$$

$$R_{\text{tot}} = \left[ \frac{1}{10 \times 5} + \frac{0.01}{0.1 \times 5} + \frac{0.3}{5} + \frac{0.02}{0.04 \times 5} + \frac{1}{20 \times 5} \right] \frac{\text{K}}{\text{W}}$$

$$R_{\text{tot}} = [0.02 + 0.02 + 0.06 + 0.10 + 0.01] \frac{\text{K}}{\text{W}} = 0.21 \frac{\text{K}}{\text{W}}$$

$$q = \frac{T_{\infty,1} - T_{\infty,2}}{R_{\text{tot}}} = \frac{(200 - 40)^\circ \text{C}}{0.21 \text{ K/W}} = 762 \text{ W.}$$

(b) It follows that

$$T_{s,1} = T_{\infty,1} - \frac{q}{h_1 A} = 200^\circ \text{C} - \frac{762 \text{ W}}{50 \text{ W/K}} = 184.8^\circ \text{C}$$

$$T_A = T_{s,1} - \frac{q L_A}{k_A A} = 184.8^\circ \text{C} - \frac{762 \text{ W} \times 0.01 \text{ m}}{0.1 \frac{\text{W}}{\text{m} \cdot \text{K}} \times 5 \text{ m}^2} = 169.6^\circ \text{C}$$

$$T_B = T_A - q R_{t,c} = 169.6^\circ \text{C} - 762 \text{ W} \times 0.06 \frac{\text{K}}{\text{W}} = 123.8^\circ \text{C}$$

$$T_{s,2} = T_B - \frac{q L_B}{k_B A} = 123.8^\circ \text{C} - \frac{762 \text{ W} \times 0.02 \text{ m}}{0.04 \frac{\text{W}}{\text{m} \cdot \text{K}} \times 5 \text{ m}^2} = 47.6^\circ \text{C}$$

$$T_{\infty,2} = T_{s,2} - \frac{q}{h_2 A} = 47.6^\circ \text{C} - \frac{762 \text{ W}}{100 \text{ W/K}} = 40^\circ \text{C}$$

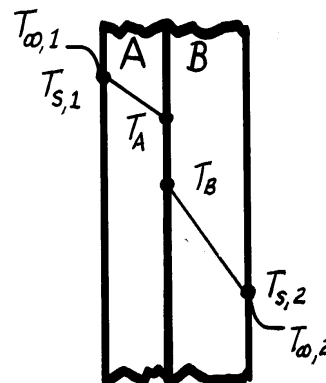

<

### PROBLEM 3.30

**KNOWN:** Outer and inner surface convection conditions associated with zirconia-coated, Inconel turbine blade. Thicknesses, thermal conductivities, and interfacial resistance of the blade materials. Maximum allowable temperature of Inconel.

**FIND:** Whether blade operates below maximum temperature. Temperature distribution in blade, with and without the TBC.

**SCHEMATIC:**

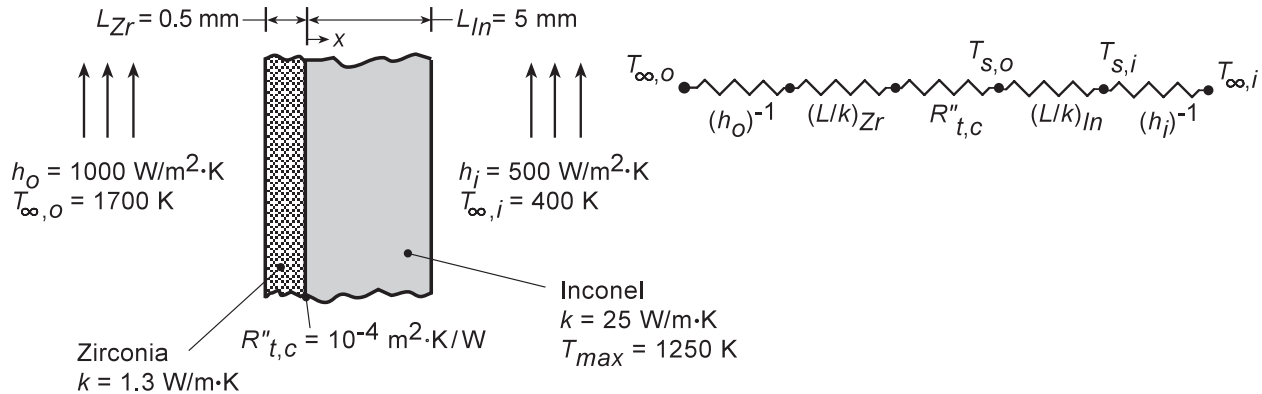

**ASSUMPTIONS:** (1) One-dimensional, steady-state conduction in a composite plane wall, (2) Constant properties, (3) Negligible radiation.

**ANALYSIS:** For a unit area, the total thermal resistance with the TBC is

$$R''_{\text{tot,w}} = h_o^{-1} + (L/k)_{Zr} + R''_{t,c} + (L/k)_{In} + h_i^{-1}$$

$$R''_{\text{tot,w}} = \left(10^{-3} + 3.85 \times 10^{-4} + 10^{-4} + 2 \times 10^{-4} + 2 \times 10^{-3}\right) \text{m}^2 \cdot \text{K/W} = 3.69 \times 10^{-3} \text{m}^2 \cdot \text{K/W}$$

With a heat flux of

$$q''_w = \frac{T_{\infty,o} - T_{\infty,i}}{R''_{\text{tot,w}}} = \frac{1300 \text{ K}}{3.69 \times 10^{-3} \text{m}^2 \cdot \text{K/W}} = 3.52 \times 10^5 \text{ W/m}^2$$

the inner and outer surface temperatures of the Inconel are

$$T_{s,i(w)} = T_{\infty,i} + (q''_w/h_i) = 400 \text{ K} + \left(3.52 \times 10^5 \text{ W/m}^2 / 500 \text{ W/m}^2 \cdot \text{K}\right) = 1104 \text{ K}$$

$$T_{s,o(w)} = T_{\infty,i} + \left[(1/h_i) + (L/k)_{In}\right] q''_w = 400 \text{ K} + \left(2 \times 10^{-3} + 2 \times 10^{-4}\right) \text{m}^2 \cdot \text{K/W} \left(3.52 \times 10^5 \text{ W/m}^2\right) = 1174 \text{ K}$$

Without the TBC,  $R''_{\text{tot,wo}} = h_o^{-1} + (L/k)_{In} + h_i^{-1} = 3.20 \times 10^{-3} \text{m}^2 \cdot \text{K/W}$ , and  $q''_{wo} = (T_{\infty,o} - T_{\infty,i})/R''_{\text{tot,wo}} = (1300 \text{ K})/3.20 \times 10^{-3} \text{m}^2 \cdot \text{K/W} = 4.06 \times 10^5 \text{ W/m}^2$ . The inner and outer surface temperatures of the Inconel are then

$$T_{s,i(wo)} = T_{\infty,i} + (q''_{wo}/h_i) = 400 \text{ K} + \left(4.06 \times 10^5 \text{ W/m}^2 / 500 \text{ W/m}^2 \cdot \text{K}\right) = 1212 \text{ K}$$

$$T_{s,o(wo)} = T_{\infty,i} + \left[(1/h_i) + (L/k)_{In}\right] q''_{wo} = 400 \text{ K} + \left(2 \times 10^{-3} + 2 \times 10^{-4}\right) \text{m}^2 \cdot \text{K/W} \left(4.06 \times 10^5 \text{ W/m}^2\right) = 1293 \text{ K}$$

Continued...

### PROBLEM 3.30 (Cont.)

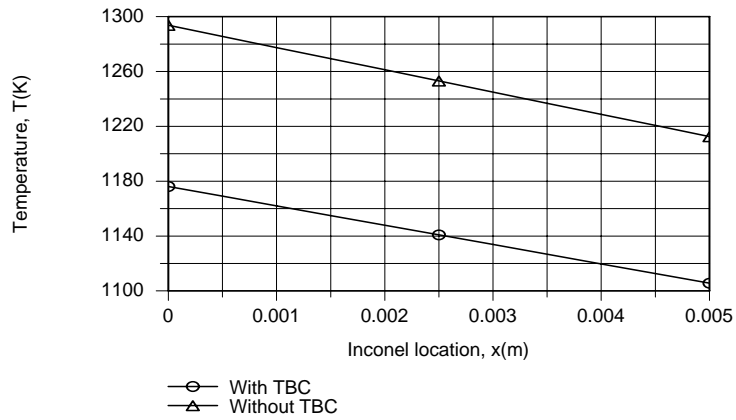

Use of the TBC facilitates operation of the Inconel below  $T_{\max} = 1250$  K.

**COMMENTS:** Since the durability of the TBC decreases with increasing temperature, which increases with increasing thickness, limits to the thickness are associated with reliability considerations.

### PROBLEM 3.31

**KNOWN:** Size and surface temperatures of a cubical freezer. Materials, thicknesses and interface resistances of freezer wall.

**FIND:** Cooling load.

**SCHEMATIC:**

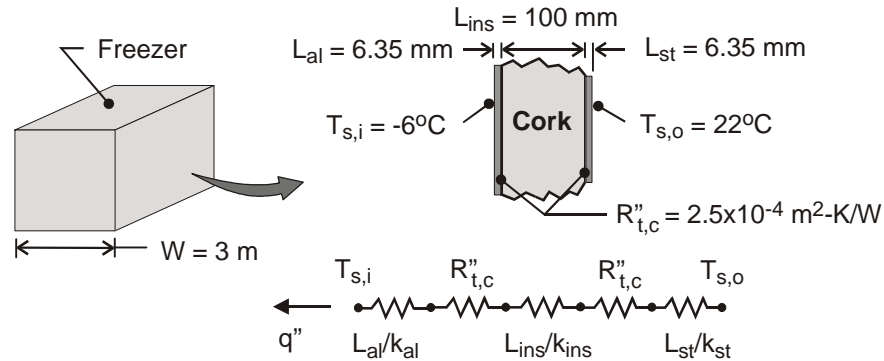

**ASSUMPTIONS:** (1) Steady-state, (2) One-dimensional conduction, (3) Constant properties.

**PROPERTIES:** Table A-1, Aluminum 2024 (~267K):  $k_{al} = 173 \text{ W/m}\cdot\text{K}$ . Table A-1, Carbon steel AISI 1010 (~295K):  $k_{st} = 64 \text{ W/m}\cdot\text{K}$ . Table A-3 (~300K):  $k_{ins} = 0.039 \text{ W/m}\cdot\text{K}$ .

**ANALYSIS:** For a unit wall surface area, the total thermal resistance of the composite wall is

$$R''_{tot} = \frac{L_{al}}{k_{al}} + R''_{t,c} + \frac{L_{ins}}{k_{ins}} + R''_{t,c} + \frac{L_{st}}{k_{st}}$$

$$R''_{tot} = \frac{0.00635\text{m}}{173 \text{ W/m}\cdot\text{K}} + 2.5 \times 10^{-4} \frac{\text{m}^2 \cdot \text{K}}{\text{W}} + \frac{0.100\text{m}}{0.039 \text{ W/m}\cdot\text{K}} + 2.5 \times 10^{-4} \frac{\text{m}^2 \cdot \text{K}}{\text{W}} + \frac{0.00635\text{m}}{64 \text{ W/m}\cdot\text{K}}$$

$$R''_{tot} = \left( 3.7 \times 10^{-5} + 2.5 \times 10^{-4} + 2.56 + 2.5 \times 10^{-4} + 9.9 \times 10^{-5} \right) \text{m}^2 \cdot \text{K} / \text{W} = 2.56 \text{ m}^2 \cdot \text{K} / \text{W}$$

Hence, the heat flux is

$$q'' = \frac{T_{s,o} - T_{s,i}}{R''_{tot}} = \frac{[22 - (-6)]^\circ\text{C}}{2.56 \text{ m}^2 \cdot \text{K} / \text{W}} = 10.9 \frac{\text{W}}{\text{m}^2}$$

and the cooling load is

$$q = A_s q'' = 6 \text{ W}^2 q'' = 54 \text{ m}^2 \times 10.9 \text{ W/m}^2 = 590 \text{ W}$$

<

**COMMENT:** Thermal resistances associated with the cladding and the adhesive joints are negligible compared to that of the insulation.

### PROBLEM 3.32

**KNOWN:** Operating conditions, measured temperatures and heat input, and theoretical thermal conductivity of a carbon nanotube.

**FIND:** (a) Thermal contact resistance between the carbon nanotube and the heating and sensing islands, (b) Fraction of total thermal resistance between the heating and sensing islands due to thermal contact resistance for  $5 \mu\text{m} \leq s \leq 20 \mu\text{m}$ .

**ASSUMPTIONS:** (1) Steady-state conditions, (2) Constant properties, (3) One-dimensional heat transfer, (4) Isothermal heating and sensing islands, (5) Negligible radiation and convection heat transfer.

**PROPERTIES:**  $k_{\text{cn,T}} = 5000 \text{ W/m}\cdot\text{K}$

**ANALYSIS:**

(a) The total thermal resistance between the heated and sensing island is

$$R_{\text{t,tot}} = \frac{s}{k_{\text{cn,T}}A_{\text{cn}}} + 2R_{\text{t,c}}$$

The value of this total resistance is the same as the one posed in Example 3.4 with  $k_{\text{cn}} = 3113 \text{ W/m}\cdot\text{K}$  and  $R_{\text{t,c}} = 0$  or

$$\frac{s}{k_{\text{cn,T}}A_{\text{cn}}} + 2R_{\text{t,c}} = \frac{s}{k_{\text{cn}}A_{\text{cn}}}$$

for which

$$\begin{aligned} R_{\text{t,c}} &= \frac{s}{2A_{\text{cn}}} \left[ \frac{1}{k_{\text{cn}}} - \frac{1}{k_{\text{cn,T}}} \right] = \frac{5 \times 10^{-6} \text{ m}}{2 \times 1.54 \times 10^{-16} \text{ m}^2} \times \left[ \frac{1}{3113 \text{ W/m}\cdot\text{K}} - \frac{1}{5000 \text{ W/m}\cdot\text{K}} \right] \\ &= 1.97 \times 10^6 \text{ K/W} \end{aligned} \quad <$$

(b) The fraction of the total resistance due to the thermal contact resistance is

$$f = \frac{2R_{\text{t,c}}}{2R_{\text{t,c}} + \left[ \frac{s}{k_{\text{cn,T}}A_{\text{cn}}} \right]} = \frac{2 \times 1.97 \times 10^6 \text{ K/W}}{2 \times 1.97 \times 10^6 \text{ K/W} + \left[ \frac{s}{5000 \text{ W/m}\cdot\text{K} \times 1.54 \times 10^{-16} \text{ m}^2} \right]}$$

As evident in the plot below, the fraction of the total thermal resistance due to thermal contact decreases from 0.38 at  $s = 5 \mu\text{m}$  to 0.13 at  $s = 20 \mu\text{m}$ .

Continued...

### PROBLEM 3.32 (Cont.)

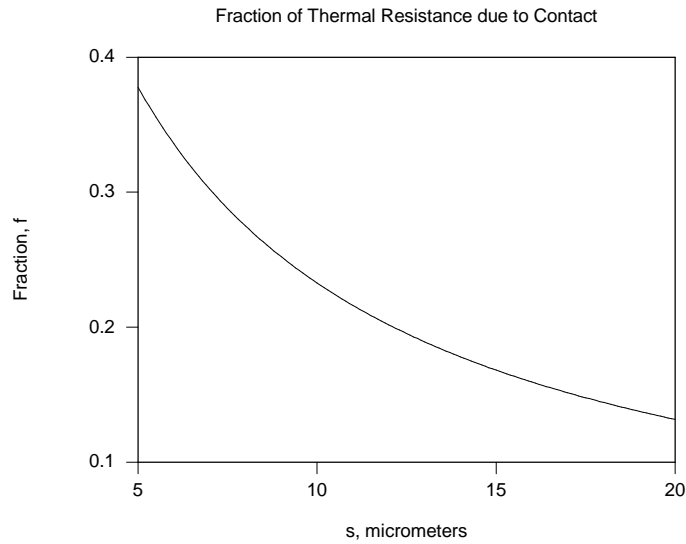

**COMMENT:** To desensitize the experiment to uncertainty due to the unknown thermal contact resistance values, a large separation distance between the islands is desired. As the separation distance becomes large, however, the surface area of the carbon nanotube increases and surface heat losses by radiation may invalidate the assumption of a linear temperature distribution along the length of the nanotube. An optimal separation distance exists that will minimize the undesirable effects of the thermal contact resistances and radiation loss from the surface of the nanotube.

### PROBLEM 3.33

**KNOWN:** Dimensions, thermal conductivity and emissivity of base plate. Temperature and convection coefficient of adjoining air. Temperature of surroundings. Maximum allowable temperature of transistor case. Case-plate interface conditions.

**FIND:** (a) Maximum allowable power dissipation for an air-filled interface, (b) Effect of convection coefficient on maximum allowable power dissipation.

**SCHEMATIC:**

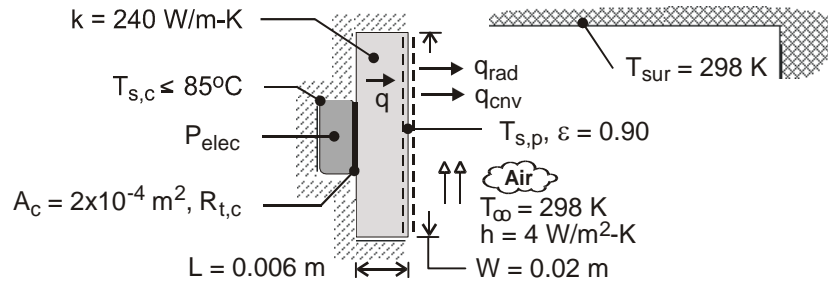

**ASSUMPTIONS:** (1) Steady-state, (2) Negligible heat transfer from the enclosure, to the surroundings. (3) One-dimensional conduction in the base plate, (4) Radiation exchange at surface of base plate is with large surroundings, (5) Constant thermal conductivity.

**PROPERTIES:** Aluminum-aluminum interface, air-filled,  $10 \mu\text{m}$  roughness,  $10^5 \text{ N/m}^2$  contact pressure (Table 3.1):  $R''_{t,c} = 2.75 \times 10^{-4} \text{ m}^2 \cdot \text{K} / \text{W}$ .

**ANALYSIS:** (a) With all of the heat dissipation transferred through the base plate,

$$P_{\text{elec}} = q = \frac{T_{s,c} - T_{\infty}}{R_{\text{tot}}} \quad (1)$$

where  $R_{\text{tot}} = R_{t,c} + R_{\text{cnd}} + \left[ (1/R_{\text{cnv}}) + (1/R_{\text{rad}}) \right]^{-1}$

$$R_{\text{tot}} = \frac{R''_{t,c}}{A_c} + \frac{L}{kW^2} + \frac{1}{W^2} \left( \frac{1}{h + h_r} \right) \quad (2)$$

$$\text{and } h_r = \varepsilon \sigma (T_{s,p} + T_{\text{sur}}) (T_{s,p}^2 + T_{\text{sur}}^2) \quad (3)$$

To obtain  $T_{s,p}$ , the following energy balance must be performed on the plate surface,

$$q = \frac{T_{s,c} - T_{s,p}}{R_{t,c} + R_{\text{cnd}}} = q_{\text{cnv}} + q_{\text{rad}} = hW^2 (T_{s,p} - T_{\infty}) + h_r W^2 (T_{s,p} - T_{\text{sur}}) \quad (4)$$

With  $R_{t,c} = 2.75 \times 10^{-4} \text{ m}^2 \cdot \text{K} / \text{W} / 2 \times 10^{-4} \text{ m}^2 = 1.375 \text{ K} / \text{W}$ ,  $R_{\text{cnd}} = 0.006 \text{ m} / (240 \text{ W} / \text{m} \cdot \text{K} \times 4 \times 10^{-4} \text{ m}^2) = 0.0625 \text{ K} / \text{W}$ , and the prescribed values of  $h$ ,  $W$ ,  $T_{\infty} = T_{\text{sur}}$  and  $\varepsilon$ , Eq. (4) yields a surface temperature of  $T_{s,p} = 357.6 \text{ K} = 84.6^\circ\text{C}$  and a power dissipation of

Continued ...

**PROBLEM 3.33 (Cont.)**

$$P_{\text{elec}} = q = 0.268 \text{ W}$$

<

The convection and radiation resistances are  $R_{\text{cnv}} = 625 \text{ K/W}$  and  $R_{\text{rad}} = 345 \text{ K/W}$ , where  $h_r = 7.25 \text{ W/m}^2 \cdot \text{K}$ .

(b) With the major contribution to the total resistance made by convection, significant benefit may be derived by increasing the value of  $h$ .

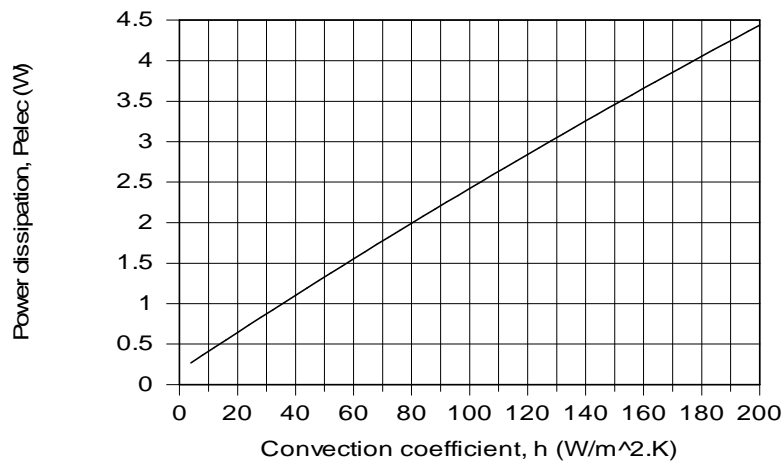

For  $h = 200 \text{ W/m}^2 \cdot \text{K}$ ,  $R_{\text{cnv}} = 12.5 \text{ K/W}$  and  $T_{\text{s,p}} = 351.6 \text{ K}$ , yielding  $R_{\text{rad}} = 355 \text{ K/W}$ . The effect of radiation is then negligible.

**COMMENTS:** (1) The plate conduction resistance is negligible, and even for  $h = 200 \text{ W/m}^2 \cdot \text{K}$ , the contact resistance is small relative to the convection resistance. However,  $R_{\text{t,c}}$  could be rendered negligible by using indium foil, instead of an air gap, at the interface. From Table 3.1,  $R''_{\text{t,c}} = 0.07 \times 10^{-4} \text{ m}^2 \cdot \text{K/W}$ , in which case  $R_{\text{t,c}} = 0.035 \text{ m} \cdot \text{K/W}$ .

(2) Because  $A_c < W^2$ , heat transfer by conduction in the plate is actually two-dimensional, rendering the conduction resistance even smaller.



### PROBLEM 3.34

**KNOWN:** Oak wood with a grain structure. Grains are highly porous and the wood is dry.

**FIND:** Fraction of oak cross-section that appears as being grained.

**SCHEMATIC:**

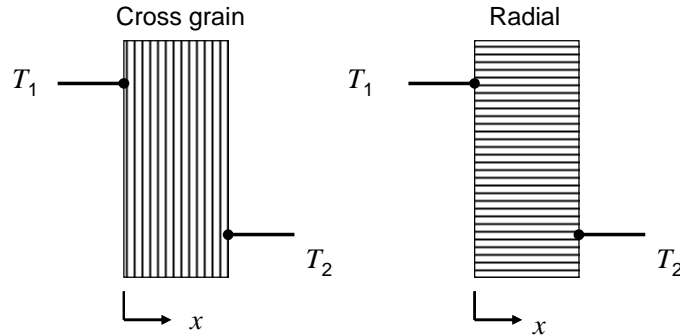

**ASSUMPTIONS:** (1) Steady-state, one-dimensional conduction, (2) Constant properties, (3) Thermal conductivity of highly porous grain is that of air.

**PROPERTIES:** Table A.3, Oak, cross grain (300 K):  $k_{\text{cross}} = 0.17 \text{ W/m}\cdot\text{K}$ ; Oak, radial (300 K):  $k_{\text{rad}} = 0.19 \text{ W/m}\cdot\text{K}$ . Table A.4, Air (300 K):  $k_{\text{air}} = 0.0263 \text{ W/m}\cdot\text{K}$ .

**ANALYSIS:** The cross grain condition is characterized by the lowest effective thermal conductivity. Therefore,

$$k_{\text{cross}} = k_{\text{min}} = 0.17 \text{ W/m}\cdot\text{K} = \frac{1}{(1-\varepsilon)/k_s + \varepsilon/k_f} = \frac{1}{(1-\varepsilon)/k_s + \varepsilon/0.0263 \text{ W/m}\cdot\text{K}} \quad (1)$$

Likewise, the radial condition exhibits the highest effective thermal conductivity. Hence,

$$k_{\text{rad}} = k_{\text{max}} = 0.19 \text{ W/m}\cdot\text{K} = \varepsilon k_f + (1-\varepsilon)k_s = \varepsilon \times 0.0263 \text{ W/m}\cdot\text{K} + (1-\varepsilon)k_s \quad (2)$$

The preceding two equations may be solved simultaneously to determine the two unknowns,  $k_s$  and  $\varepsilon$ , yielding

$$\varepsilon = 0.022 \quad <$$

**COMMENTS:** (1) The predicted value of the solid thermal conductivity is  $k_s = 0.1937 \text{ W/m}\cdot\text{K}$ . (2) The predicted value of  $\varepsilon$  is rather low. In reality, the thermal conductivity of the grain is greater than that of air. Doubling the value of  $k_f$  to  $0.0526 \text{ W/m}\cdot\text{K}$  yields  $\varepsilon = 0.061$ , which is consistent with estimates of  $\varepsilon$  for oak.

### PROBLEM 3.35

**KNOWN:** Density of glass fiber insulation.

**FIND:** Maximum and minimum possible values of the effective thermal conductivity of the insulation at  $T = 300$  K, and comparison with the value listed in Table A.3.

**SCHEMATIC:**

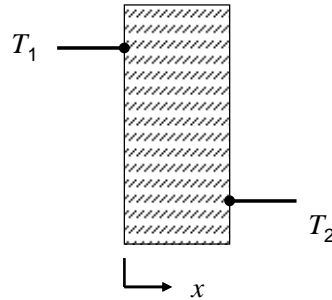

**ASSUMPTIONS:** (1) Constant properties, (2) Negligible radiation, (3) Atmospheric pressure.

**PROPERTIES:** Table A.3, Glass (plate):  $k_{gl} = 1.4$  W/m·K,  $\rho_{gl} = 2500$  kg/m<sup>3</sup>. Glass fiber batt (paper faced,  $\rho_{ins} = 28$  kg/m<sup>3</sup>)  $k_{ins} = 0.038$  W/m·K. Table A.4, Air (300 K):  $k_{air} = 0.0263$  W/m·K,  $\rho_{air} = 1.1614$  kg/m<sup>3</sup>. Given:  $\rho_{ins} = 28$  kg/m<sup>3</sup>.

**ANALYSIS:** The density of the glass fiber insulation may be related to the density of the air and glass phases, and the volume fraction,  $\varepsilon$ , as follows.

$$\rho_{ins} = \varepsilon\rho_{air} + (1 - \varepsilon)\rho_{gl}$$

Therefore,

$$\varepsilon = \frac{\rho_{gl} - \rho_{ins}}{\rho_{gl} - \rho_{air}} = \frac{2500 - 28}{2500 - 1.164} = 0.989$$

The minimum effective thermal conductivity is

$$k_{eff,min} = \frac{1}{(1 - \varepsilon)/k_{glass} + \varepsilon/k_{air}} = \frac{1}{(1 - 0.989)/1.4 \text{ W/m} \cdot \text{K} + 0.989/0.0263 \text{ W/m} \cdot \text{K}} <$$

$$= 0.0265 \text{ W/m} \cdot \text{K}$$

The maximum effective thermal conductivity is

$$k_{eff,max} = \varepsilon k_f + (1 - \varepsilon)k_s = 0.989 \times 0.0263 \text{ W/m} \cdot \text{K} + (1 - 0.989) \times 1.4 \text{ W/m} \cdot \text{K} <$$

$$= 0.0414 \text{ W/m} \cdot \text{K}$$

As expected, the predicted minimum and maximum effective thermal conductivities bracket the actual effective thermal conductivity of  $k_{ins} = 0.038$  W/m·K. <

**COMMENT:** Radiation internal to the glass fiber batting may be significant. If so, this will reduce the insulating capability of the matt.

### PROBLEM 3.36

**KNOWN:** Thermal conductivity of ice cream containing no air at  $T = -20^\circ\text{C}$ . Shape and volume fraction of air bubbles.

**FIND:** The thermal conductivity of commercial ice cream characterized by  $\varepsilon = 0.20$  at  $T = -20^\circ\text{C}$ .

**SCHEMATIC:**

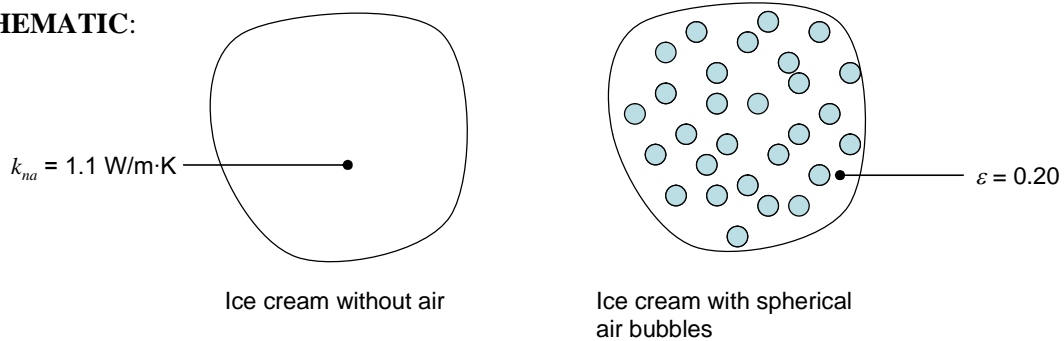

**ASSUMPTIONS:** (1) Constant properties, (2) Spherical air bubbles.

**PROPERTIES:** Table A.4, Air (300 K):  $k_{\text{air}} = 0.0225 \text{ W/m}\cdot\text{K}$ .

**ANALYSIS:** Maxwell's expression for the effective thermal conductivity may be used, with  $k_f = k_{\text{air}}$  and  $k_s = k_{na}$ . Hence,

$$\begin{aligned}
 k_{\text{eff}} &= \left[ \frac{k_f + 2k_s - 2\varepsilon(k_s - k_f)}{k_f + 2k_s + \varepsilon(k_s - k_f)} \right] k_s \\
 &= \left[ \frac{0.0225 \text{ W/m}\cdot\text{K} + 2 \times 1.1 \text{ W/m}\cdot\text{K} - 2 \times 0.2 \times (1.1 \text{ W/m}\cdot\text{K} - 0.0225 \text{ W/m}\cdot\text{K})}{0.0225 \text{ W/m}\cdot\text{K} + 2 \times 1.1 \text{ W/m}\cdot\text{K} + 0.2 \times (1.1 \text{ W/m}\cdot\text{K} - 0.0225 \text{ W/m}\cdot\text{K})} \right] \times 1.1 \text{ W/m}\cdot\text{K} \\
 &= 0.81 \text{ W/m}\cdot\text{K}
 \end{aligned}$$

**COMMENTS:** (1) The reduction in the effective thermal conductivity due to the presence of the air bubbles is 26%. (2) The predicted thermal conductivity is in good agreement with measured values. Furthermore, Maxwell's equation accurately predicts the measured thermal conductivity of ice cream over the range  $0 \leq \varepsilon \leq 0.5$ . The thermal conductivity as well as additional thermophysical properties of ice cream containing spherical air bubbles (called *overrun* ice cream) are available in Cogne, Andrieu, Laurent, Besson and Noequet, "Experimental Data and Modelling of Thermal Properties of Ice Cream," *Journal of Food Engineering*, Vol. 58, p, 331, 2003.

### PROBLEM 3.37

**KNOWN:** Volume fraction of air in stone mix concrete, forming a lightweight aggregate concrete.

**FIND:** Values of the lightweight aggregate's thermal conductivity, density and specific heat.

**SCHEMATIC:**

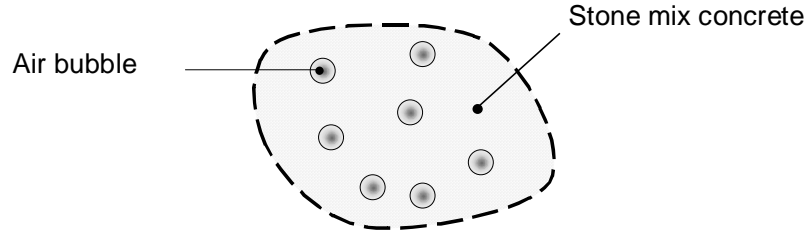

**ASSUMPTIONS:** (1) Constant properties.

**PROPERTIES:** Table A.3 ( $T = 300$  K): Stone mix concrete;  $k_s = 1.4$  W/m·K,  $\rho_s = 2300$  kg/m<sup>3</sup>,  $c_{p,s} = 880$  J/kg·K. Table A.4 ( $T = 300$  K): Air;  $k_f = 0.0263$  W/m·K,  $\rho_f = 1.1614$  kg/m<sup>3</sup>,  $c_{p,f} = 1007$  J/kg·K.

**ANALYSIS:** Maxwell's expression for the effective thermal conductivity may be used. Hence,

$$\begin{aligned}
 k_{\text{eff},a} &= \left[ \frac{k_f + 2k_s - 2\varepsilon(k_s - k_f)}{k_f + 2k_s + \varepsilon(k_s - k_f)} \right] k_s \\
 &= \left[ \frac{0.0263 \text{ W/m}\cdot\text{K} + 2 \times 1.4 \text{ W/m}\cdot\text{K} - 2 \times 0.35 \times (1.4 \text{ W/m}\cdot\text{K} - 0.0263 \text{ W/m}\cdot\text{K})}{0.0263 \text{ W/m}\cdot\text{K} + 2 \times 1.4 \text{ W/m}\cdot\text{K} + 0.35 \times (1.4 \text{ W/m}\cdot\text{K} - 0.0263 \text{ W/m}\cdot\text{K})} \right] \times 1.4 \text{ W/m}\cdot\text{K} \\
 &= 0.789 \text{ W/m}\cdot\text{K} <
 \end{aligned}$$

Considering the control volume shown in the schematic to be of unit volume, we note that by conservation of mass,  $\rho_a = \rho_s(1 - \varepsilon) + \rho_f\varepsilon = 2300 \text{ kg/m}^3 \times (1 - 0.35) + 1.1614 \text{ kg/m}^3 \times 0.35 = 1495 \text{ kg/m}^3$ . <

Similarly, by conservation of energy for the unit volume,  $\rho_a c_{p,a} = 1495 \text{ kg/m}^3 \times c_{p,a} = \rho_s c_{p,s}(1 - \varepsilon) + \rho_f c_{p,f} \varepsilon = 2300 \text{ kg/m}^3 \times 880 \text{ J/kg}\cdot\text{K} \times (1 - 0.35) + 1.1614 \text{ kg/m}^3 \times 1007 \text{ J/kg}\cdot\text{K} \times 0.35 = 1.32 \times 10^6 \text{ J/K}$ .  
Therefore,  $c_{p,a} = 1.32 \times 10^6 \text{ J/K} / 1495 \text{ kg/m}^3 = 880 \text{ J/kg}\cdot\text{K}$  <

**COMMENT:** The thermal conductivity and density are reduced significantly relative to the stone mix concrete values.

### PROBLEM 3.38

**KNOWN:** Porosity distribution in a one-dimensional plane wall,  $\varepsilon(x)$ , thermal conductivities of solid and fluid, wall thickness, temperature at  $x = 0$ , and heat flux.

**FIND:** Plot of the temperature distribution using the expressions for the maximum and minimum effective thermal conductivities, Maxwell's expression, and for the constant property case;  $k_{\text{eff}}(x) = k_s$ .

**SCHEMATIC:**

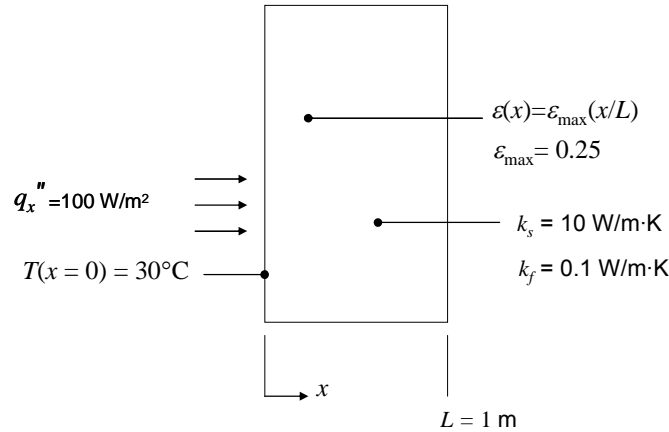

**ASSUMPTIONS:** (1) Constant properties within the two phases, (2) Negligible radiation, (3) No thermal energy generation, (4) Steady state, one-dimensional heat transfer.

**PROPERTIES:** Given:  $k_s = 10 \text{ W/m}\cdot\text{K}$ ,  $k_f = 0.1 \text{ W/m}\cdot\text{K}$ .

**ANALYSIS:** Fourier's law may be expressed as

$$\frac{dT}{dx} = -\frac{q_x''}{k_{\text{eff}}} \quad (1)$$

We note that the heat flux is constant. The effective thermal conductivity may be evaluated from the various formulae as follows.

Maximum effective thermal conductivity:

$$k_{\text{eff}} = k_{\text{eff,max}} = \varepsilon k_f + (1 - \varepsilon) k_s \quad (2)$$

Minimum effective thermal conductivity:

$$k_{\text{eff}} = k_{\text{eff,min}} = \frac{1}{(1 - \varepsilon)/k_s + \varepsilon/k_f} \quad (3)$$

Maxwell's expression:

$$k_{\text{eff}} = k_{\text{eff,Max}} = \left[ \frac{k_f + 2k_s - 2\varepsilon(k_s - k_f)}{k_f + 2k_s + \varepsilon(k_s - k_f)} \right] k_s \quad (4)$$

Continued...

### PROBLEM 3.38 (Cont.)

No dispersed phase:

$$k_{\text{eff}} = k_s \quad (5)$$

Equations 2, 3, 4, or 5 may be substituted into Equation 1 and the expression may be integrated numerically using a commercial code. IHT was used to generate the following temperature distributions.

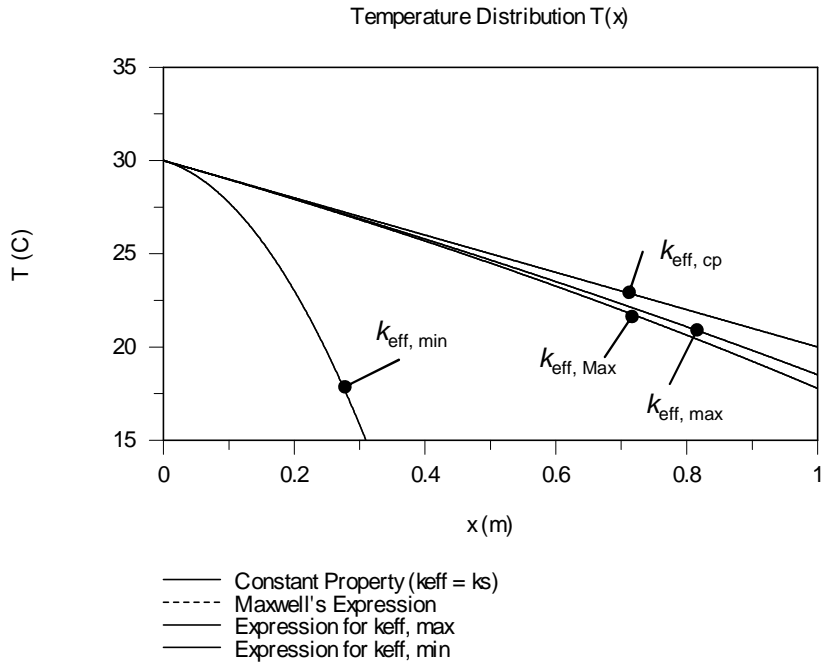

The constant property solution exhibits a linear temperature distribution.

The introduction of the low thermal conductivity matter within the medium decreases its effective thermal conductivity. From Equation (1), the temperature gradient must become larger in order to sustain the imposed heat flux as the effective thermal conductivity decreases. The increased temperature gradients are evident in the plot.

Predictions using Maxwell's expression, and the expression for the maximum effective thermal conductivity are in relatively good agreement. This is because Maxwell's expression describes conduction within a porous medium that is characterized by a contiguous solid phase; thermal energy can be transferred across the entire thickness of the plane wall within the solid phase only. The concept of a contiguous solid phase is also embedded in the assumptions that were made in deriving the expression for  $k_{\text{eff, max}}$ . In contrast, the predictions using the expression for the minimum effective thermal conductivity are not consistent with the other predictions. In deriving the expression for  $k_{\text{eff, min}}$ , it is assumed that thermal energy *must* be transferred through the low thermal conductivity fluid phase as it propagates through the porous wall. The non-contiguous solid phase associated with the minimum thermal conductivity expression manifests itself as very large temperature gradients through the plane wall.

Continued...

### PROBLEM 3.38 (Cont.)

**COMMENTS:** (1) It is important to be cognizant of the morphology of the porous medium before selecting the appropriate expression for the effective thermal conductivity. (2) The IHT code is shown below.

```
//Input phase properties, dimensions, thermal boundary condition, and porosity parameter.
```

```
ks = 10           //W/mK
kf = 0.1         //W/mK
L = 1            //m
emax = 0.25      //dimensionless
qflux = 100      //W/m^2
T1 = 30         //Degrees C
eps = emax*(x/L)
```

```
//Constant Property Solution
Der(Tcp,x) = -qflux/ks
```

```
//Minimum Effective Thermal Conductivity Solution
Der(Tmin,x) = -qflux/keffmin
keffmin = 1/dena
dena=(1-eps)/ks + eps/kf
```

```
//Maximum Effective Thermal Conductivity Solution
Der(Tmax,x) = -qflux/keffmax
keffmax = eps*kf + (1 - eps)*ks
```

```
//Maxwell's Expression
Der(TMax,x) = -qflux/keffMax
keffMax = ks*num/denb
num = kf+2*ks-2*eps*(ks-kf)
denb = kf+2*ks+eps*(ks-kf)
```

### PROBLEM 3.39

**KNOWN:** Conduction in a conical section with prescribed diameter,  $D$ , as a function of  $x$  in the form  $D = ax^{1/2}$ .

**FIND:** (a) Temperature distribution,  $T(x)$ , (b) Heat transfer rate,  $q_x$ .

**SCHEMATIC:**

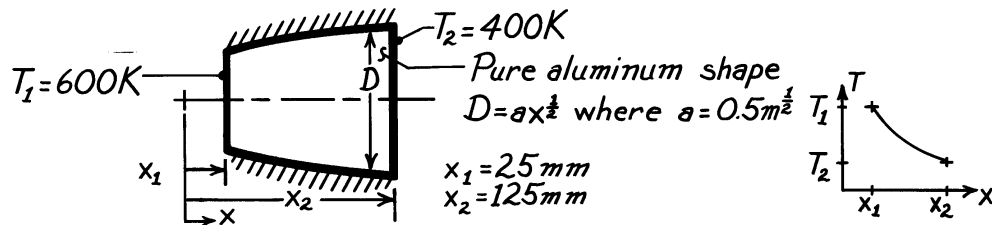

**ASSUMPTIONS:** (1) Steady-state conditions, (2) One-dimensional conduction in  $x$ -direction, (3) No internal heat generation, (4) Constant properties.

**PROPERTIES:** Table A-1, Pure Aluminum (500K):  $k = 236 \text{ W/m}\cdot\text{K}$ .

**ANALYSIS:** (a) Based upon the assumptions, and following the same methodology of Example 3.4,  $q_x$  is a constant independent of  $x$ . Accordingly,

$$q_x = -kA \frac{dT}{dx} = -k \left[ \pi \left( ax^{1/2} \right)^2 / 4 \right] \frac{dT}{dx} \quad (1)$$

using  $A = \pi D^2 / 4$  where  $D = ax^{1/2}$ . Separating variables and identifying limits,

$$\frac{4q_x}{\pi a^2 k} \int_{x_1}^x \frac{dx}{x} = - \int_{T_1}^T dT. \quad (2)$$

Integrating and solving for  $T(x)$  and then for  $T_2$ ,

$$T(x) = T_1 - \frac{4q_x}{\pi a^2 k} \ln \frac{x}{x_1} \quad T_2 = T_1 - \frac{4q_x}{\pi a^2 k} \ln \frac{x_2}{x_1}. \quad (3,4)$$

Solving Eq. (4) for  $q_x$  and then substituting into Eq. (3) gives the results,

$$q_x = -\frac{\pi}{4} a^2 k (T_1 - T_2) / \ln (x_1 / x_2) \quad (5)$$

$$T(x) = T_1 + (T_1 - T_2) \frac{\ln (x/x_1)}{\ln (x_1/x_2)}. \quad <$$

From Eq. (1) note that  $(dT/dx) \cdot x = \text{Constant}$ . It follows that  $T(x)$  has the distribution shown above.

(b) The heat rate follows from Eq. (5),

$$q_x = \frac{\pi}{4} \times 0.5^2 \text{ m} \times 236 \frac{\text{W}}{\text{m}\cdot\text{K}} (600 - 400) \text{ K} / \ln \frac{25}{125} = 5.76 \text{ kW}. \quad <$$



### PROBLEM 3.40

**KNOWN:** Geometry and surface conditions of a truncated solid cone.

**FIND:** (a) Temperature distribution, (b) Rate of heat transfer across the cone.

**SCHEMATIC:**

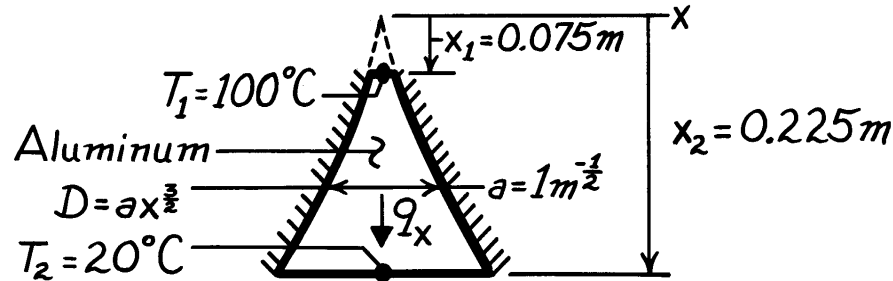

**ASSUMPTIONS:** (1) Steady-state conditions, (2) One-dimensional conduction in  $x$ , (3) Constant properties.

**PROPERTIES:** Table A-1, Aluminum (333K):  $k = 238 \text{ W/m}\cdot\text{K}$ .

**ANALYSIS:** (a) From Fourier's law, Eq. 2.1, with  $A = \pi D^2 / 4 = (\pi a^2 / 4) x^3$ , it follows that

$$\frac{4q_x dx}{\pi a^2 x^3} = -k dT.$$

Hence, since  $q_x$  is independent of  $x$ ,

$$\frac{4q_x}{\pi a^2} \int_{x_1}^x \frac{dx}{x^3} = -k \int_{T_1}^T dT$$

or

$$\frac{4q_x}{\pi a^2} \left[ -\frac{1}{2x^2} \right]_{x_1}^x = -k(T - T_1).$$

Hence

$$T = T_1 + \frac{2q_x}{\pi a^2 k} \left[ \frac{1}{x^2} - \frac{1}{x_1^2} \right]. \quad <$$

(b) From the foregoing expression, it also follows that

$$q_x = \frac{\pi a^2 k}{2} \frac{T_2 - T_1}{\left[ 1/x_2^2 - 1/x_1^2 \right]}$$

$$q_x = \frac{\pi (1\text{m}^{-1}) 238 \text{ W/m}\cdot\text{K}}{2} \times \frac{(20 - 100)^\circ \text{C}}{\left[ (0.225)^{-2} - (0.075)^{-2} \right] \text{m}^{-2}}$$

$$q_x = 189 \text{ W}. \quad <$$

**COMMENTS:** The foregoing results are approximate due to use of a one-dimensional model in treating what is inherently a two-dimensional problem.

### PROBLEM 3.41

**KNOWN:** Temperature dependence of the thermal conductivity,  $k$ .

**FIND:** Heat flux and form of temperature distribution for a plane wall.

**SCHEMATIC:**

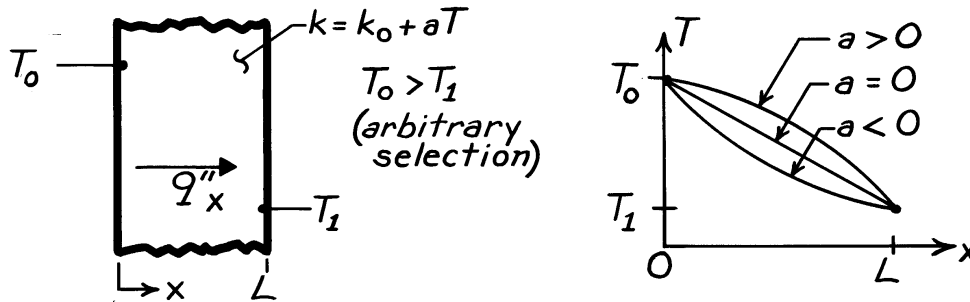

**ASSUMPTIONS:** (1) One-dimensional conduction through a plane wall, (2) Steady-state conditions, (3) No internal heat generation.

**ANALYSIS:** For the assumed conditions,  $q_x''$  and  $A(x)$  are constant and Eq. 3.26 gives

$$q_x'' \int_0^L dx = - \int_{T_0}^{T_1} (k_0 + aT) dT$$

$$q_x'' = \frac{1}{L} \left[ k_0 (T_0 - T_1) + \frac{a}{2} (T_0^2 - T_1^2) \right].$$

From Fourier's law,

$$q_x'' = -(k_0 + aT) dT/dx.$$

Hence, since the product of  $(k_0 + aT)$  and  $dT/dx$  is constant, decreasing  $T$  with increasing  $x$  implies,

$a > 0$ : decreasing  $(k_0 + aT)$  and increasing  $|dT/dx|$  with increasing  $x$

$a = 0$ :  $k = k_0 \Rightarrow$  constant  $(dT/dx)$

$a < 0$ : increasing  $(k_0 + aT)$  and decreasing  $|dT/dx|$  with increasing  $x$ .

The temperature distributions appear as shown in the above sketch.

### PROBLEM 3.42

**KNOWN:** Temperature dependence of tube wall thermal conductivity.

**FIND:** Expressions for heat transfer per unit length and tube wall thermal (conduction) resistance.

**SCHEMATIC:**

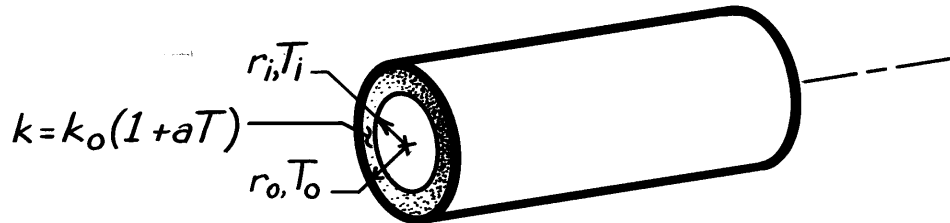

**ASSUMPTIONS:** (1) Steady-state conditions, (2) One-dimensional radial conduction, (3) No internal heat generation.

**ANALYSIS:** From Eq. 3.29, the appropriate form of Fourier's law is

$$q_r = -kA_r \frac{dT}{dr} = -k(2\pi rL) \frac{dT}{dr}$$

$$q'_r = -2\pi kr \frac{dT}{dr}$$

$$q'_r = -2\pi rk_o(1 + aT) \frac{dT}{dr}.$$

Separating variables,

$$-\frac{q'_r}{2\pi} \frac{dr}{r} = k_o(1 + aT) dT$$

and integrating across the wall, find

$$-\frac{q'_r}{2\pi} \int_{r_i}^{r_o} \frac{dr}{r} = k_o \int_{T_i}^{T_o} (1 + aT) dT$$

$$-\frac{q'_r}{2\pi} \ln \frac{r_o}{r_i} = k_o \left[ T + \frac{aT^2}{2} \right] \Big|_{T_i}^{T_o}$$

$$-\frac{q'_r}{2\pi} \ln \frac{r_o}{r_i} = k_o \left[ (T_o - T_i) + \frac{a}{2} (T_o^2 - T_i^2) \right]$$

$$q'_r = -2\pi k_o \left[ 1 + \frac{a}{2} (T_o + T_i) \right] \frac{(T_o - T_i)}{\ln(r_o/r_i)}. \quad <$$

It follows that the overall thermal resistance per unit length is

$$R'_t = \frac{T_i - T_o}{q'_r} = \frac{\ln(r_o/r_i)}{2\pi k_o \left[ 1 + \frac{a}{2} (T_o + T_i) \right]}. \quad <$$

**COMMENT:** Note the necessity of the stated assumptions to treating  $q'_r$  as independent of  $r$ .

### PROBLEM 3.43

**KNOWN:** Steady-state temperature distribution of convex shape for material with  $k = k_0(1 + \alpha T)$  where  $\alpha$  is a constant and the mid-point temperature is  $\Delta T_0$  higher than expected for a linear temperature distribution.

**FIND:** Relationship to evaluate  $\alpha$  in terms of  $\Delta T_0$  and  $T_1, T_2$  (the temperatures at the boundaries).

**SCHEMATIC:**

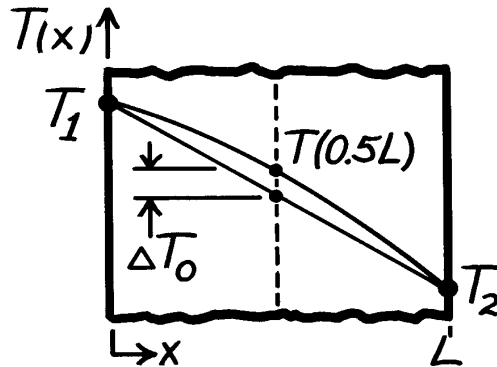

**ASSUMPTIONS:** (1) Steady-state conditions, (2) One-dimensional conduction, (3) No internal heat generation, (4)  $\alpha$  is positive and constant.

**ANALYSIS:** At any location in the wall, Fourier's law has the form

$$q_x'' = -k_0(1 + \alpha T) \frac{dT}{dx}. \quad (1)$$

Since  $q_x''$  is a constant, we can separate Eq. (1), identify appropriate integration limits, and integrate to obtain

$$\int_0^L q_x'' dx = -\int_{T_1}^{T_2} k_0(1 + \alpha T) dT \quad (2)$$

$$q_x'' = -\frac{k_0}{L} \left[ \left( T_2 + \frac{\alpha T_2^2}{2} \right) - \left( T_1 + \frac{\alpha T_1^2}{2} \right) \right]. \quad (3)$$

We could perform the same integration, but with the upper limits at  $x = L/2$ , to obtain

$$q_x'' = -\frac{2k_0}{L} \left[ \left( T_{L/2} + \frac{\alpha T_{L/2}^2}{2} \right) - \left( T_1 + \frac{\alpha T_1^2}{2} \right) \right] \quad (4)$$

where

$$T_{L/2} = T(L/2) = \frac{T_1 + T_2}{2} + \Delta T_0. \quad (5)$$

Setting Eq. (3) equal to Eq. (4), substituting from Eq. (5) for  $T_{L/2}$ , and solving for  $\alpha$ , it follows that

$$\alpha = \frac{2\Delta T_0}{\left( T_2^2 + T_1^2 \right) / 2 - \left[ (T_1 + T_2) / 2 + \Delta T_0 \right]^2}. \quad <$$

### PROBLEM 3.44

**KNOWN:** Construction and dimensions of a device to measure the temperature of a surface. Ambient and sensing temperatures, and thermal resistance between the sensing element and the pivot point.

**FIND:** (a) Thermal resistance between the surface temperature and the sensing temperature, (b) Surface temperature for  $T_{\text{sen}} = 28.5^\circ\text{C}$ .

**SCHEMATIC:**

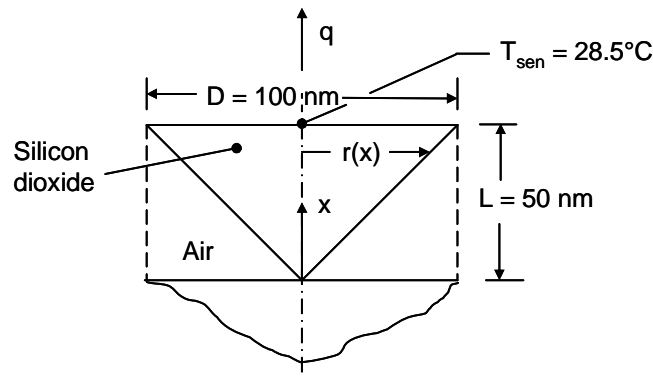

**ASSUMPTIONS:** (1) Steady-state conditions, (2) One-dimensional heat transfer, (3) Negligible nanoscale effects, (4) Constant properties.

**PROPERTIES:** Table A.2, polycrystalline silicon dioxide (300 K):  $k = 1.38 \text{ W/m}\cdot\text{K}$ . Table A.4, air (300 K):  $k = 0.0263 \text{ W/m}\cdot\text{K}$ .

**ANALYSIS:**

(a) At any  $x$  location, heat transfer in the  $x$ -direction occurs by conduction in the air as well as conduction in the probe. Applying Fourier's law,

$$q_x = -k_a A_a \frac{dT}{dx} - k_p A_p \frac{dT}{dx} \quad (1)$$

Since the probe radius is  $r = Dx/2L$ , the probe area is

$$A_p = \frac{\pi D^2}{4L^2} x^2 \quad \text{and} \quad A_a = \frac{\pi D^2}{4} - A_p = \frac{\pi D^2}{4} \left[ 1 - \frac{x^2}{L^2} \right] \quad (2a, 2b)$$

Substituting Eqs. (2a) and (2b) into Eq. (1) yields

$$q_x = -\frac{\pi D^2}{4L^2} \left[ k_a (L^2 - x^2) + k_p x^2 \right] \frac{dT}{dx}$$

Separating variables and integrating,

Continued...



### PROBLEM 3.45

**KNOWN:** Thickness and inner surface temperature of calcium silicate insulation on a steam pipe. Convection and radiation conditions at outer surface.

**FIND:** (a) Heat loss per unit pipe length for prescribed insulation thickness and outer surface temperature. (b) Heat loss and radial temperature distribution as a function of insulation thickness.

**SCHEMATIC:**

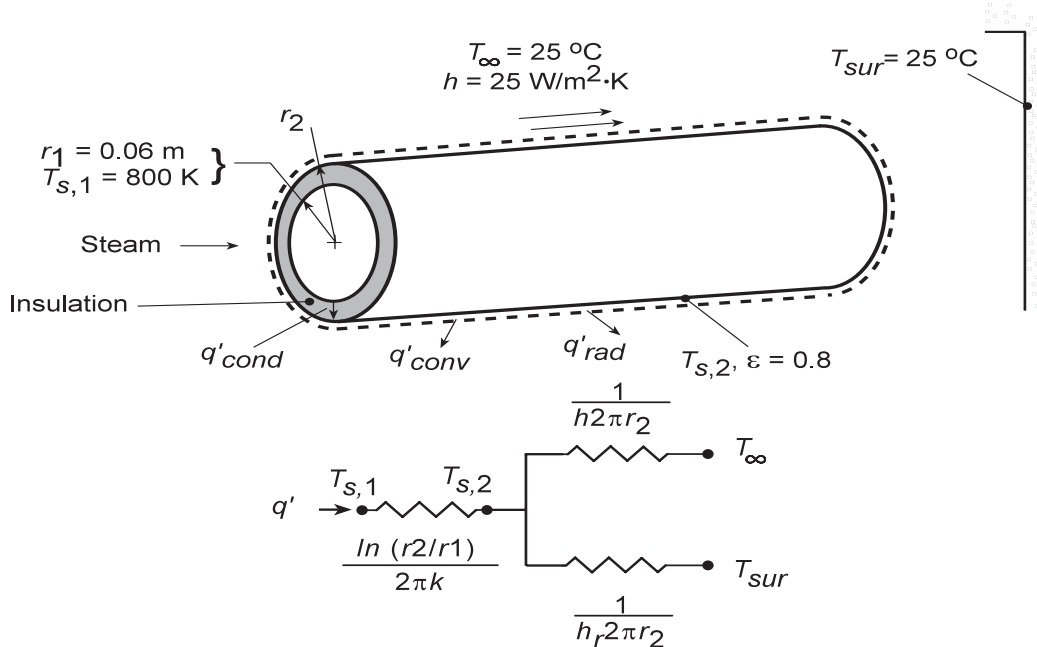

**ASSUMPTIONS:** (1) Steady-state conditions, (2) One-dimensional conduction, (3) Constant properties.

**PROPERTIES:** Table A-3, Calcium Silicate ( $T = 645 \text{ K}$ ):  $k = 0.089 \text{ W/m}\cdot\text{K}$ .

**ANALYSIS:** (a) From Eq. 3.32 with  $T_{s,2} = 490 \text{ K}$ , the heat rate per unit length is

$$q' = q_r/L = \frac{2\pi k (T_{s,1} - T_{s,2})}{\ln(r_2/r_1)}$$

$$q' = \frac{2\pi (0.089 \text{ W/m}\cdot\text{K})(800 - 490) \text{ K}}{\ln(0.08 \text{ m}/0.06 \text{ m})}$$

$$q' = 603 \text{ W/m} .$$

(b) Performing an energy for a control surface around the outer surface of the insulation, it follows that

$$q'_{\text{cond}} = q'_{\text{conv}} + q'_{\text{rad}}$$

$$\frac{T_{s,1} - T_{s,2}}{\ln(r_2/r_1)/2\pi k} = \frac{T_{s,2} - T_{\infty}}{1/(2\pi r_2 h)} + \frac{T_{s,2} - T_{\text{sur}}}{1/(2\pi r_2 h_r)}$$

where  $h_r = \varepsilon\sigma(T_{s,2} + T_{\text{sur}})(T_{s,2}^2 + T_{\text{sur}}^2)$ . Solving this equation for  $T_{s,2}$ , the heat rate may be determined from

$$q' = 2\pi r_2 \left[ h(T_{s,2} - T_{\infty}) + h_r(T_{s,2} - T_{\text{sur}}) \right]$$

Continued...

### PROBLEM 3.45 (Cont.)

and from Eq. 3.31 the temperature distribution is

$$T(r) = \frac{T_{s,1} - T_{s,2}}{\ln(r_1/r_2)} \ln\left(\frac{r}{r_2}\right) + T_{s,2}$$

As shown below, the outer surface temperature of the insulation  $T_{s,2}$  and the heat loss  $q'$  decay precipitously with increasing insulation thickness from values of  $T_{s,2} = T_{s,1} = 800$  K and  $q' = 11,600$  W/m, respectively, at  $r_2 = r_1$  (no insulation).

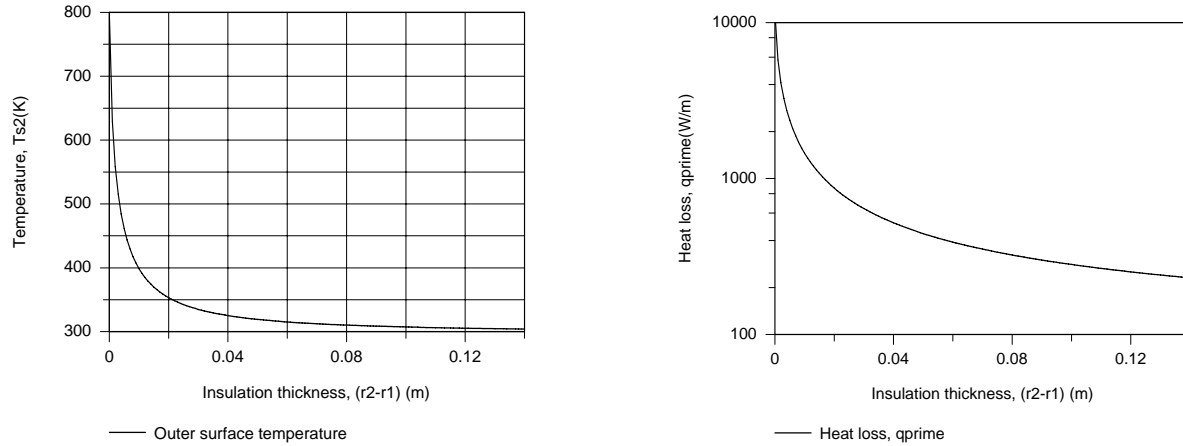

When plotted as a function of a dimensionless radius,  $(r - r_1)/(r_2 - r_1)$ , the temperature decay becomes more pronounced with increasing  $r_2$ .

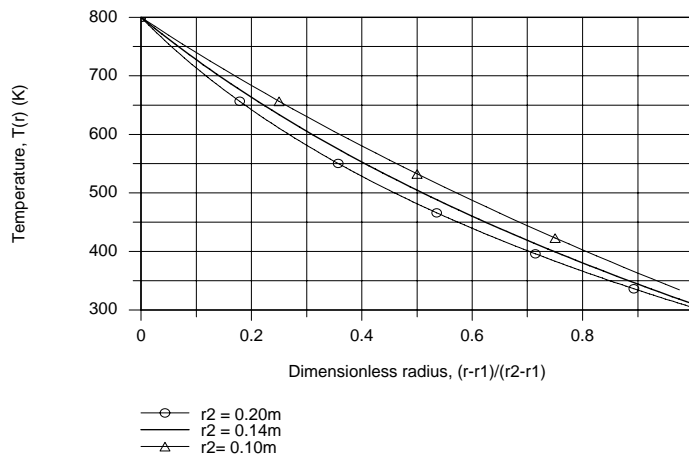

Note that  $T(r_2) = T_{s,2}$  increases with decreasing  $r_2$  and a linear temperature distribution is approached as  $r_2$  approaches  $r_1$ .

**COMMENTS:** An insulation layer thickness of 20 mm is sufficient to maintain the outer surface temperature and heat rate below 350 K and 1000 W/m, respectively.



### PROBLEM 3.46

**KNOWN:** Temperature and volume of hot water heater. Nature of heater insulating material. Ambient air temperature and convection coefficient. Unit cost of electric power.

**FIND:** Heater dimensions and insulation thickness for which annual cost of heat loss is less than \$50.

**SCHEMATIC:**

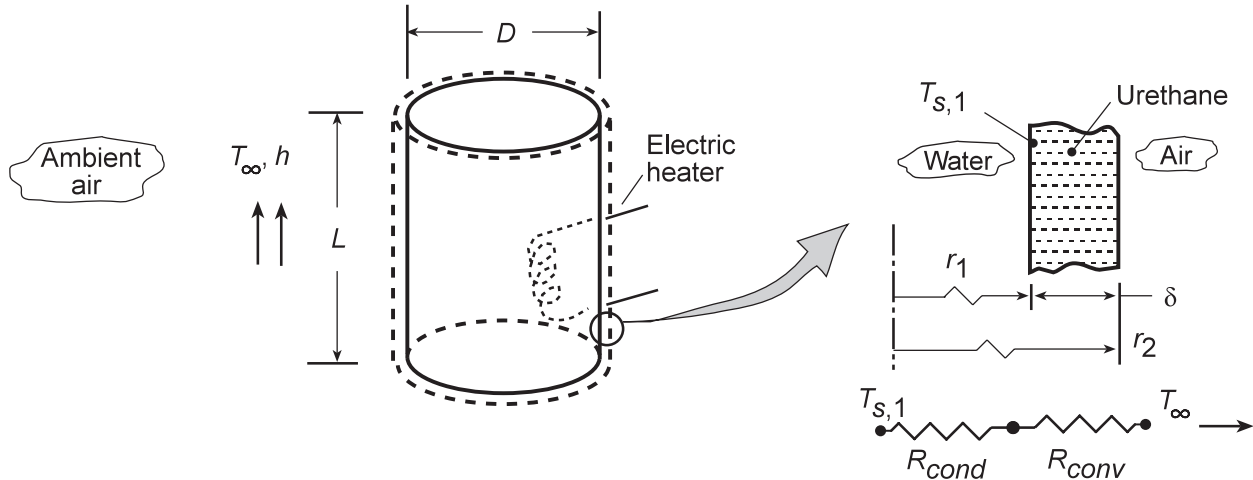

**ASSUMPTIONS:** (1) One-dimensional, steady-state conduction through side and end walls, (2) Conduction resistance dominated by insulation, (3) Inner surface temperature is approximately that of the water ( $T_{s,1} = 55^\circ\text{C}$ ), (4) Constant properties, (5) Negligible radiation due to low emissivity foil covering on insulation.

**PROPERTIES:** Table A.3, Urethane Foam ( $T = 300\text{ K}$ ):  $k = 0.026\text{ W/m}\cdot\text{K}$ .

**ANALYSIS:** To minimize heat loss, tank dimensions which minimize the total surface area,  $A_{s,t}$ , should be selected. With  $L = 4\forall/\pi D^2$ ,  $A_{s,t} = \pi DL + 2\left(\pi D^2/4\right) = 4\forall/D + \pi D^2/2$ , and the tank diameter for which  $A_{s,t}$  is an extremum is determined from the requirement

$$dA_{s,t}/dD = -4\forall/D^2 + \pi D = 0$$

It follows that

$$D = (4\forall/\pi)^{1/3} \quad \text{and} \quad L = (4\forall/\pi)^{1/3}$$

With  $d^2A_{s,t}/dD^2 = 8\forall/D^3 + \pi > 0$ , the foregoing conditions yield the desired minimum in  $A_{s,t}$ . Hence, for  $\forall = 100\text{ gal} \times 0.00379\text{ m}^3/\text{gal} = 0.379\text{ m}^3$ ,

$$D_{op} = L_{op} = 0.784\text{ m} \quad \leftarrow$$

For an annual cost of heat loss of \$50 and a unit electric power cost of \$0.18/kWh

$$Q_{\text{annual}} = \$50.00/\$0.18/\text{kWh} = 278\text{ kWh}$$

The energy loss rate is therefore

$$q = Q_{\text{annual}}/(\text{hours per year}) = 278 \times 10^3\text{ W}\cdot\text{h}/[(365\text{ days})(24\text{ h/day})] = 31.7\text{ W}$$

Continued...

### PROBLEM 3.46 (Cont.)

The total heat loss through the side and end walls is

$$q = \frac{T_{s,1} - T_{\infty}}{\frac{\ln(r_2/r_1)}{2\pi k L_{op}} + \frac{1}{h 2\pi r_2 L_{op}}} + \frac{2(T_{s,1} - T_{\infty})}{\frac{\delta}{k(\pi D_{op}^2/4)} + \frac{1}{h(\pi D_{op}^2/4)}}$$

With  $r_1 = D_{op}/2 = 0.392$  m and  $r_2 = r_1 + \delta$ , everything is known except for the insulation thickness,  $\delta$ .

$$q = 31.7 \text{ W} = \frac{(55 - 20)^{\circ} \text{C}}{\frac{\ln((0.392 + \delta)/0.392)}{2\pi(0.026 \text{ W/m} \cdot \text{K})0.784 \text{ m}} + \frac{1}{(2 \text{ W/m}^2 \cdot \text{K})2\pi(0.392 \text{ m} + \delta)0.784 \text{ m}}} + \frac{2(55 - 20)^{\circ} \text{C}}{\frac{\delta}{(0.026 \text{ W/m} \cdot \text{K})\pi(0.784 \text{ m})^2/4} + \frac{1}{(2 \text{ W/m}^2 \cdot \text{K})\pi(0.784 \text{ m})^2/4}}$$

Solving by trial and error yields an insulation thickness of

$$\delta = 68 \text{ mm}$$

<

**COMMENTS:** Cylindrical containers of aspect ratio  $L/D = 1$  are seldom used because of floor space constraints. Choosing  $L/D = 2$ ,  $\forall = \pi D^3/2$  and  $D = (2\forall/\pi)^{1/3} = 0.623$  m. Hence,  $L = 1.245$  m,  $r_1 = 0.312$  m and  $r_2 = 0.337$  m. It follows that  $q = 34$  W and  $C = \$53.62$ . The 7% increase in the annual cost of the heat loss is small, providing little justification for using the optimal heater dimensions.

### PROBLEM 3.47

**KNOWN:** Dimensions of components of a pipe-in-pipe device. Thermal conductivity of materials, inner and outer heat transfer coefficients, outer fluid temperature.

**FIND:** (a) Maximum crude oil temperature to not exceed allowable service temperature of polyurethane. (b) Maximum crude oil temperature to not exceed allowable service temperature of polyurethane after insertion of aerogel layer.

**SCHEMATIC:**

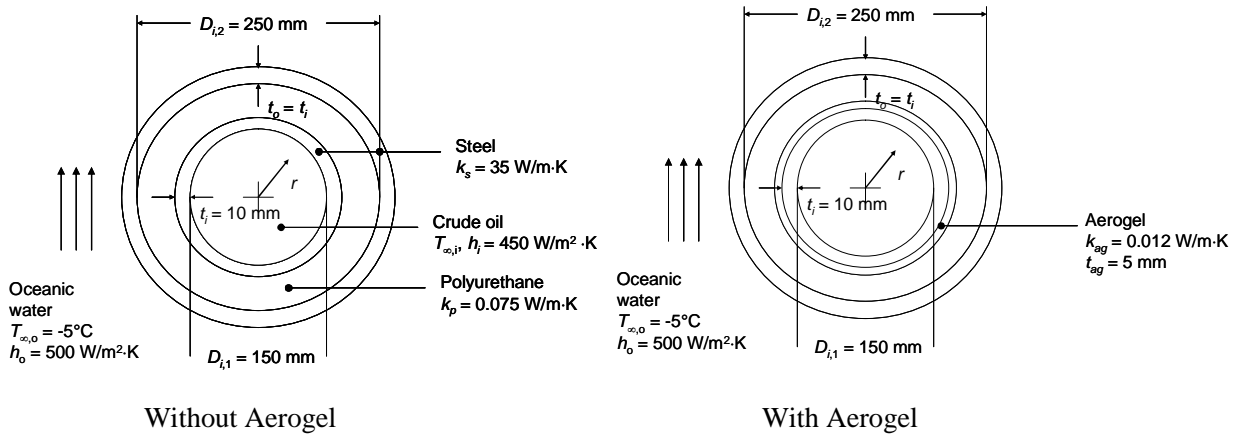

**ASSUMPTIONS:** (1) Steady-state, one-dimensional conditions, (2) Negligible contact resistances, (3) Constant properties.

**PROPERTIES:** Given, Steel:  $k = 35 \text{ W/m}\cdot\text{K}$ ; polyurethane:  $k = 0.075 \text{ W/m}\cdot\text{K}$ ; aerogel:  $k = 0.012 \text{ W/m}\cdot\text{K}$ .

**ANALYSIS:** (a) The thermal resistance network for the case without the aerogel is shown below. The maximum polyurethane temperature occurs at its inner surface.

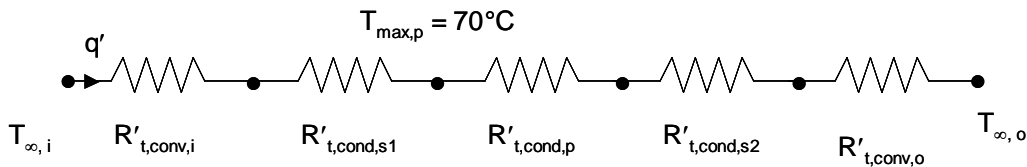

Equating the heat rate per unit length of tubing from the crude oil to the inner surface of the polyurethane with the heat rate from the inner surface of the polyurethane to the oceanic waters yields

$$q' = \frac{T_{\infty,i} - T_{\max,p}}{R'_{t,conv,i} + R'_{t,cond,s1}} = \frac{T_{\max,p} - T_{\infty,o}}{R'_{t,cond,p} + R'_{t,cond,s2} + R'_{t,conv,o}}$$

which may be rearranged to give

$$T_{\infty,i} = \frac{(T_{\max,p} - T_{\infty,o})(R'_{t,conv,i} + R'_{t,cond,s1})}{(R'_{t,cond,p} + R'_{t,cond,s2} + R'_{t,conv,o})} + T_{\max,p} \quad (1)$$

Continued...

### PROBLEM 3.47 (Cont.)

The various thermal resistances are evaluated as follows.

$$R'_{t,conv,i} = \frac{1}{450 \text{ W/m}^2 \cdot \text{K} \times \pi \times 0.150 \text{ m}} = 4.716 \times 10^{-3} \frac{\text{m} \cdot \text{K}}{\text{W}} ; R'_{t,cond,s1} = \frac{\ln[(150+20)/150]}{2 \times \pi \times 35 \text{ W/m} \cdot \text{K}} = 569.2 \times 10^{-6} \frac{\text{m} \cdot \text{K}}{\text{W}}$$

$$R'_{t,cond,p} = \frac{\ln[250/(150+20)]}{2 \times \pi \times 0.075 \text{ W/m} \cdot \text{K}} = 818.4 \times 10^{-3} \frac{\text{m} \cdot \text{K}}{\text{W}} ; R'_{t,cond,s2} = \frac{\ln[(250+20)/250]}{2 \times \pi \times 35 \text{ W/m} \cdot \text{K}} = 350.0 \times 10^{-6} \frac{\text{m} \cdot \text{K}}{\text{W}}$$

$$R'_{t,conv,o} = \frac{1}{500 \text{ W/m}^2 \cdot \text{K} \times \pi \times 0.270 \text{ m}} = 2.358 \times 10^{-3} \frac{\text{m} \cdot \text{K}}{\text{W}}$$

Substituting into Equation (1) yields

$$T_{\infty,i} = \frac{[70^\circ\text{C} - (-5^\circ\text{C})](4.716 \times 10^{-3} \frac{\text{m} \cdot \text{K}}{\text{W}} + 569.2 \times 10^{-6} \frac{\text{m} \cdot \text{K}}{\text{W}})}{(818.4 \times 10^{-3} \frac{\text{m} \cdot \text{K}}{\text{W}} + 350 \times 10^{-6} \frac{\text{m} \cdot \text{K}}{\text{W}} + 2.358 \times 10^{-3} \frac{\text{m} \cdot \text{K}}{\text{W}})} + 70^\circ\text{C} = 70.5^\circ\text{C} \quad <$$

(b) The thermal resistance network for the case with the aerogel is shown below.

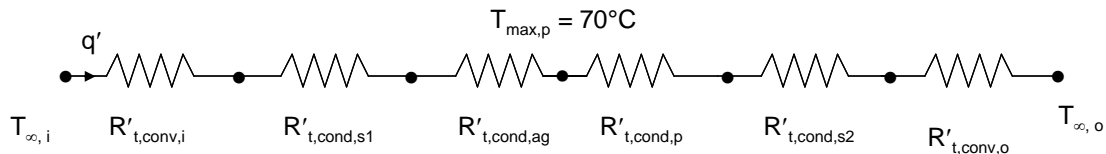

The thermal resistance values are as before, except the conduction resistance per unit length in the polyurethane is decreased, since its thickness is reduced relative to part (a). In addition, the conduction resistance for the aerogel must be evaluated. These two resistances are:

$$R'_{t,conv,ag} = \frac{\ln[(150+20+10)/(150+20)]}{2 \times \pi \times 0.012 \text{ W/m} \cdot \text{K}} = 758 \times 10^{-3} \frac{\text{m} \cdot \text{K}}{\text{W}} ; R'_{t,cond,p} = \frac{\ln[250/180]}{2 \times \pi \times 0.075 \text{ W/m} \cdot \text{K}} = 697 \times 10^{-3} \frac{\text{m} \cdot \text{K}}{\text{W}}$$

Incorporating the aerogel resistance, Equation (1) becomes

$$T_{\infty,i} = \frac{(T_{\max,p} - T_{\infty,o})(R'_{t,conv,i} + R'_{t,cond,s1} + R'_{t,cond,ag})}{(R'_{t,cond,p} + R'_{t,cond,s2} + R'_{t,conv,o})} + T_{\max,p}$$

Substituting values yields

Continued...

**PROBLEM 3.47 (Cont.)**

$$T_{\infty,i} = \frac{[70^{\circ}\text{C} - (-5^{\circ}\text{C})](4.716 \times 10^{-3} \frac{\text{m} \cdot \text{K}}{\text{W}} + 569.2 \times 10^{-6} \frac{\text{m} \cdot \text{K}}{\text{W}} + 758 \times 10^{-3} \frac{\text{m} \cdot \text{K}}{\text{W}})}{(697 \times 10^{-3} \frac{\text{m} \cdot \text{K}}{\text{W}} + 350 \times 10^{-6} \frac{\text{m} \cdot \text{K}}{\text{W}} + 2.358 \times 10^{-3} \frac{\text{m} \cdot \text{K}}{\text{W}})} + 70^{\circ}\text{C}$$
$$= 151.8^{\circ}\text{C} \quad <$$

**COMMENTS:** Assuming the dynamic viscosity of crude oil is similar to that of engine oil, we may evaluate the viscosity of the oil at the two maximum operating temperatures. From Table A-5 at  $T = 70.5^{\circ}\text{C} = 343 \text{ K}$ ,  $\mu = 0.046 \text{ N}\cdot\text{s}/\text{m}^2$ . At  $T = 151.8^{\circ}\text{C} = 425 \text{ K}$ ,  $\mu = 0.517 \text{ N}\cdot\text{s}/\text{m}^2$ . The viscosity of the oil with the aerogel insulation is  $0.046/0.517 = 0.09$ , or only 9% of the viscosity of the oil without the aerogel. Savings in pumping costs and/or increases in oil production rates could be realized with use of the aerogel pipe-in-pipe concept.

### PROBLEM 3.48

**KNOWN:** Inner and outer radii of a tube wall which is heated electrically at its outer surface and is exposed to a fluid of prescribed  $h$  and  $T_\infty$ . Thermal contact resistance between heater and tube wall and wall inner surface temperature.

**FIND:** Heater power per unit length required to maintain a heater temperature of  $25^\circ\text{C}$ .

**SCHEMATIC:**

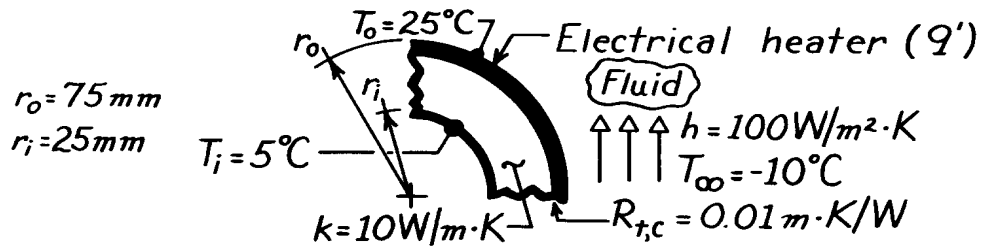

**ASSUMPTIONS:** (1) Steady-state conditions, (2) One-dimensional conduction, (3) Constant properties, (4) Negligible temperature drop across heater.

**ANALYSIS:** The thermal circuit has the form

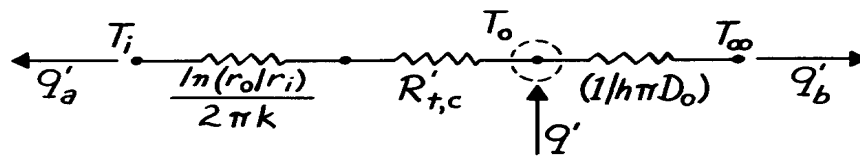

Applying an energy balance to a control surface about the heater,

$$q' = q'_a + q'_b$$

$$q' = \frac{T_o - T_i}{\frac{\ln(r_o/r_i)}{2\pi k} + R'_{t,c}} + \frac{T_o - T_\infty}{(1/h\pi D_o)}$$

$$q' = \frac{(25-5)^\circ\text{C}}{\frac{\ln(75\text{mm}/25\text{mm})}{2\pi \times 10 \text{ W/m}\cdot\text{K}} + 0.01 \frac{\text{m}\cdot\text{K}}{\text{W}}} + \frac{[25 - (-10)]^\circ\text{C}}{\left[1 / \left(100 \text{ W/m}^2 \cdot \text{K} \times \pi \times 0.15\text{m}\right)\right]}$$

$$q' = (728 + 1649) \text{ W/m}$$

$$q' = 2377 \text{ W/m.} \quad <$$

**COMMENTS:** The conduction, contact and convection resistances are 0.0175, 0.01 and 0.021  $\text{m}\cdot\text{K}/\text{W}$ , respectively,

### PROBLEM 3.49

**KNOWN:** Inner and outer radii of a tube wall which is heated electrically at its outer surface. Inner and outer wall temperatures. Temperature of fluid adjoining outer wall.

**FIND:** Effect of wall thermal conductivity, thermal contact resistance, and convection coefficient on total heater power and heat rates to outer fluid and inner surface.

**SCHEMATIC:**

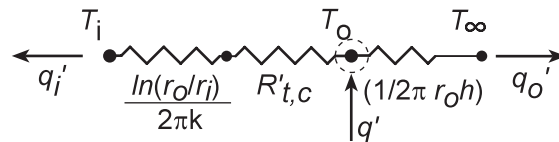
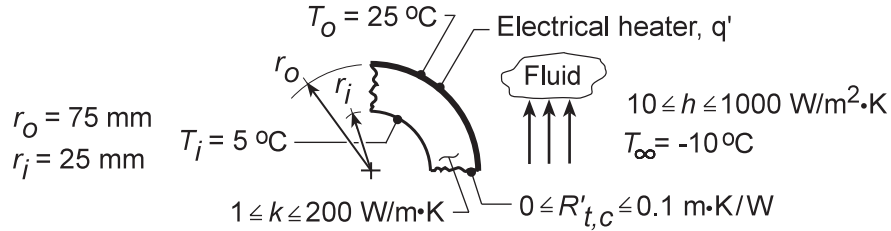

**ASSUMPTIONS:** (1) Steady-state conditions, (2) One-dimensional conduction, (3) Constant properties, (4) Negligible temperature drop across heater, (5) Negligible radiation.

**ANALYSIS:** Applying an energy balance to a control surface about the heater,

$$q' = q'_i + q'_o$$

$$q' = \frac{T_o - T_i}{\frac{\ln(r_o/r_i)}{2\pi k} + R'_{t,c}} + \frac{T_o - T_\infty}{(1/2\pi r_o h)}$$

Selecting nominal values of  $k = 10 \text{ W/m}\cdot\text{K}$ ,  $R'_{t,c} = 0.01 \text{ m}\cdot\text{K/W}$  and  $h = 100 \text{ W/m}^2\cdot\text{K}$ , the following parametric variations are obtained

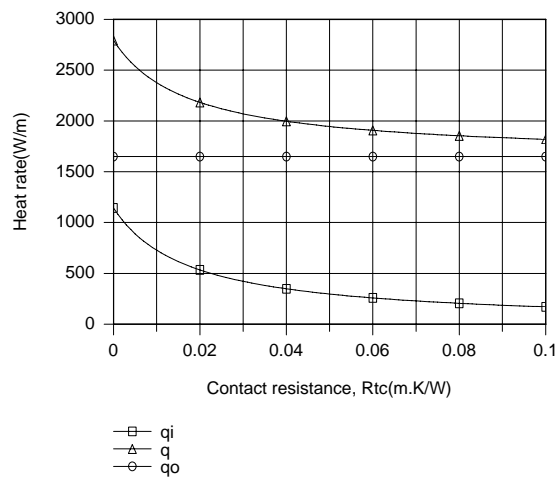
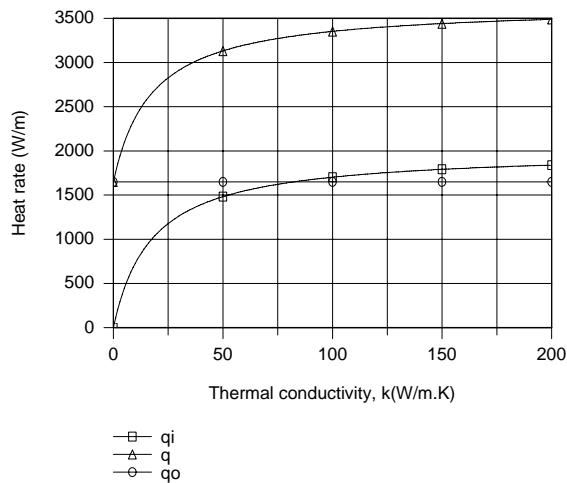

Continued...

### PROBLEM 3.49 (Cont.)

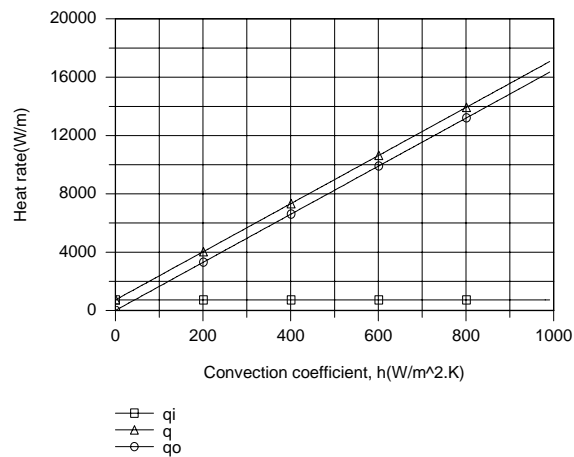

For a prescribed value of  $h$ ,  $q'_O$  is fixed, while  $q'_i$ , and hence  $q'$ , increase and decrease, respectively, with increasing  $k$  and  $R'_{t,c}$ . These trends are attributable to the effects of  $k$  and  $R'_{t,c}$  on the total (conduction plus contact) resistance separating the heater from the inner surface. For fixed  $k$  and  $R'_{t,c}$ ,  $q'_i$  is fixed, while  $q'_O$ , and hence  $q'$ , increase with increasing  $h$  due to a reduction in the convection resistance.

**COMMENTS:** For the prescribed nominal values of  $k$ ,  $R'_{t,c}$  and  $h$ , the electric power requirement is  $q' = 2377$  W/m. To maintain the prescribed heater temperature,  $q'$  would increase with any changes which reduce the conduction, contact and/or convection resistances.



### PROBLEM 3.50

**KNOWN:** Wall thickness and diameter of stainless steel tube. Inner and outer fluid temperatures and convection coefficients.

**FIND:** (a) Heat gain per unit length of tube, (b) Effect of adding a 10 mm thick layer of insulation to outer surface of tube.

**SCHEMATIC:**

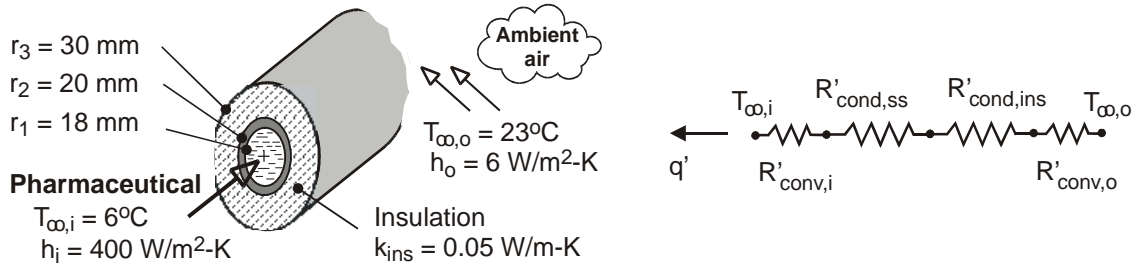

**ASSUMPTIONS:** (1) Steady-state conditions, (2) One-dimensional radial conduction, (3) Constant properties, (4) Negligible contact resistance between tube and insulation, (5) Negligible effect of radiation.

**PROPERTIES:** Table A-1, Ss 304 (~280K):  $k_{st} = 14.2 \text{ W/m}\cdot\text{K}$ .

**ANALYSIS:** (a) Without the insulation, the total thermal resistance per unit length is

$$R'_{tot} = R'_{conv,i} + R'_{cond,st} + R'_{conv,o} = \frac{1}{2\pi r_1 h_i} + \frac{\ln(r_2/r_1)}{2\pi k_{st}} + \frac{1}{2\pi r_2 h_o}$$

$$R'_{tot} = \frac{1}{2\pi (0.018\text{m}) 400 \text{ W/m}^2 \cdot \text{K}} + \frac{\ln(20/18)}{2\pi (14.2 \text{ W/m}\cdot\text{K})} + \frac{1}{2\pi (0.020\text{m}) 6 \text{ W/m}^2 \cdot \text{K}}$$

$$R'_{tot} = (0.0221 + 1.18 \times 10^{-3} + 1.33) \text{ m}\cdot\text{K/W} = 1.35 \text{ m}\cdot\text{K/W}$$

The heat gain per unit length is then

$$q' = \frac{T_{\infty,o} - T_{\infty,i}}{R'_{tot}} = \frac{(23 - 6)^\circ\text{C}}{1.35 \text{ m}\cdot\text{K/W}} = 12.6 \text{ W/m} \quad <$$

(b) With the insulation, the total resistance per unit length is now  $R'_{tot} = R'_{conv,i} + R'_{cond,st} + R'_{cond,ins} + R'_{conv,o}$ , where  $R'_{conv,i}$  and  $R'_{cond,st}$  remain the same. The thermal resistance of the insulation is

$$R'_{cond,ins} = \frac{\ln(r_3/r_2)}{2\pi k_{ins}} = \frac{\ln(30/20)}{2\pi (0.05 \text{ W/m}\cdot\text{K})} = 1.29 \text{ m}\cdot\text{K/W}$$

and the outer convection resistance is now

$$R'_{conv,o} = \frac{1}{2\pi r_3 h_o} = \frac{1}{2\pi (0.03\text{m}) 6 \text{ W/m}^2 \cdot \text{K}} = 0.88 \text{ m}\cdot\text{K/W}$$

The total resistance is now

$$R'_{tot} = (0.0221 + 1.18 \times 10^{-3} + 1.29 + 0.88) \text{ m}\cdot\text{K/W} = 2.20 \text{ m}\cdot\text{K/W}$$

Continued ...

### PROBLEM 3.50 (Cont.)

and the heat gain per unit length is

$$q' = \frac{T_{\infty,o} - T_{\infty,i}}{R'_{\text{tot}}} = \frac{17^\circ\text{C}}{2.20 \text{ m}\cdot\text{K}/\text{W}} = 7.7 \text{ W/m}$$

**COMMENTS:** (1) The validity of assuming negligible radiation may be assessed for the worst case condition corresponding to the bare tube. Assuming a tube outer surface temperature of  $T_s = T_{\infty,i} = 279\text{K}$ , large surroundings at  $T_{\text{sur}} = T_{\infty,o} = 296\text{K}$ , and an emissivity of  $\varepsilon = 0.7$  (Table A-11), the heat gain due to net radiation exchange with the surroundings is  $q'_{\text{rad}} = \varepsilon\sigma(2\pi r_2)(T_{\text{sur}}^4 - T_s^4) = 8.1 \text{ W/m}$ .

Hence, the net rate of heat transfer by radiation to the tube surface is comparable to that by convection, and the assumption of negligible radiation is inappropriate.

(2) If heat transfer from the air is by natural convection, the value of  $h_o$  with the insulation would actually be less than the value for the bare tube, thereby further reducing the heat gain. Use of the insulation would also increase the outer surface temperature, thereby reducing net radiation transfer from the surroundings.

(3) The critical radius is  $r_{\text{cr}} = k_{\text{ins}}/h \approx 8 \text{ mm} < r_2$ . Hence, as indicated by the calculations, heat transfer is reduced by the insulation.

### PROBLEM 3.51

**KNOWN:** Diameter, wall thickness and thermal conductivity of steel tubes. Temperature of steam flowing through the tubes. Thermal conductivity of insulation and emissivity of aluminum sheath. Temperature of ambient air and surroundings. Convection coefficient at outer surface and maximum allowable surface temperature.

**FIND:** (a) Minimum required insulation thickness ( $r_3 - r_2$ ) and corresponding heat loss per unit length, (b) Effect of insulation thickness on outer surface temperature and heat loss.

**SCHEMATIC:**

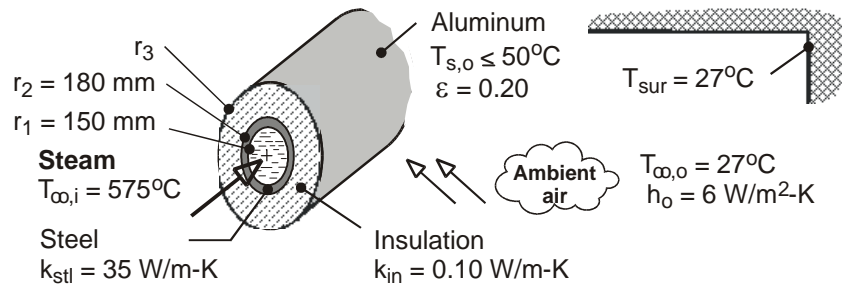

**ASSUMPTIONS:** (1) Steady-state, (2) One-dimensional radial conduction, (3) Negligible contact resistances at the material interfaces, (4) Negligible steam side convection resistance ( $T_{\infty,i} = T_{s,i}$ ), (5) Negligible conduction resistance for aluminum sheath, (6) Constant properties, (7) Large surroundings.

**ANALYSIS:** (a) To determine the insulation thickness, an energy balance must be performed at the outer surface, where  $q' = q'_{\text{conv},o} + q'_{\text{rad}}$ . With  $q'_{\text{conv},o} = 2\pi r_3 h_o (T_{s,o} - T_{\infty,o})$ ,  $q'_{\text{rad}} = 2\pi r_3 \epsilon \sigma (T_{s,o}^4 - T_{\text{sur}}^4)$ ,  $q' = (T_{s,i} - T_{s,o}) / (R'_{\text{cond},st} + R'_{\text{cond},ins})$ ,  $R'_{\text{cond},st} = \ln(r_2/r_1) / 2\pi k_{st}$ , and  $R'_{\text{cond},ins} = \ln(r_3/r_2) / 2\pi k_{ins}$ , it follows that

$$\frac{2\pi (T_{s,i} - T_{s,o})}{\frac{\ln(r_2/r_1)}{k_{st}} + \frac{\ln(r_3/r_2)}{k_{ins}}} = 2\pi r_3 \left[ h_o (T_{s,o} - T_{\infty,o}) + \epsilon \sigma (T_{s,o}^4 - T_{\text{sur}}^4) \right]$$

$$\frac{2\pi (848 - 323) \text{ K}}{\frac{\ln(0.18/0.15)}{35 \text{ W/m}\cdot\text{K}} + \frac{\ln(r_3/0.18)}{0.10 \text{ W/m}\cdot\text{K}}} = 2\pi r_3 \left[ 6 \text{ W/m}^2 \cdot \text{K} (323 - 300) \text{ K} + 0.20 \times 5.67 \times 10^{-8} \text{ W/m}^2 \cdot \text{K}^4 (323^4 - 300^4) \text{ K}^4 \right]$$

A trial-and-error solution yields  $r_3 = 0.394 \text{ m} = 394 \text{ mm}$ , in which case the insulation thickness is

$$t_{\text{ins}} = r_3 - r_2 = 214 \text{ mm} \quad <$$

The heat rate is then

$$q' = \frac{2\pi (848 - 323) \text{ K}}{\frac{\ln(0.18/0.15)}{35 \text{ W/m}\cdot\text{K}} + \frac{\ln(0.394/0.18)}{0.10 \text{ W/m}\cdot\text{K}}} = 420 \text{ W/m} \quad <$$

(b) The effects of  $r_3$  on  $T_{s,o}$  and  $q'$  have been computed and are shown below.

Continued ...

**PROBLEM 3.51 (Cont.)**

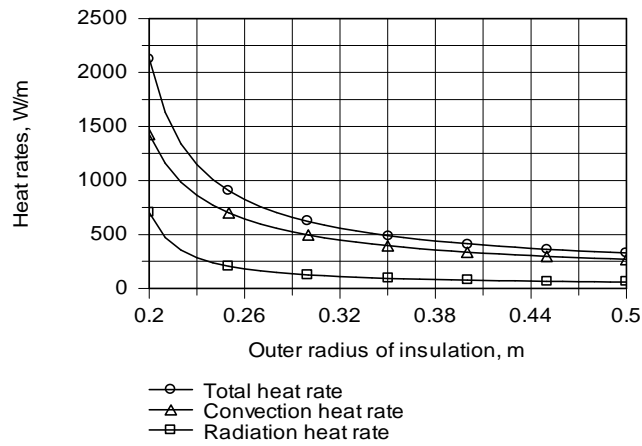
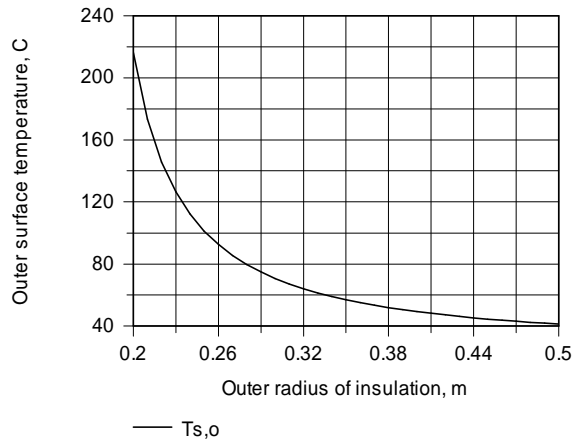

Beyond  $r_3 \approx 0.40$  m, there are rapidly diminishing benefits associated with increasing the insulation thickness.

**COMMENTS:** Note that the thermal resistance of the insulation is much larger than that for the tube wall. For the conditions of Part (a), the radiation coefficient is  $h_r = 1.37$  W/m, and the heat loss by radiation is less than 25% of that due to natural convection ( $q'_{rad} = 78$  W/m,  $q'_{conv,o} = 342$  W/m).

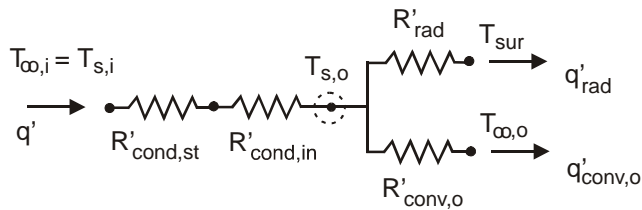

### PROBLEM 3.52

**KNOWN:** Thin electrical heater fitted between two concentric cylinders, the outer surface of which experiences convection.

**FIND:** (a) Electrical power required to maintain outer surface at a specified temperature, (b) Temperature at the center.

**SCHEMATIC:**

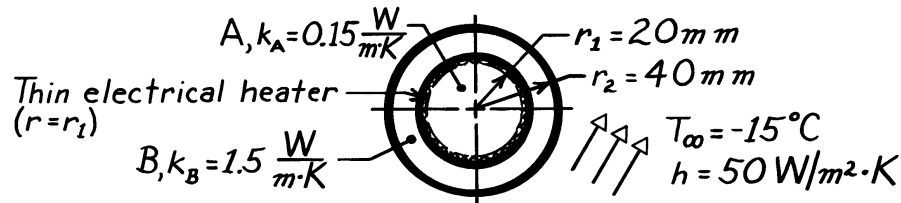

**ASSUMPTIONS:** (1) One-dimensional, radial conduction, (2) Steady-state conditions, (3) Heater element has negligible thickness, (4) Negligible contact resistance between cylinders and heater, (5) Constant properties, (6) No generation.

**ANALYSIS:** (a) Perform an energy balance on the composite system to determine the power required to maintain  $T(r_2) = T_s = 5^\circ\text{C}$ .

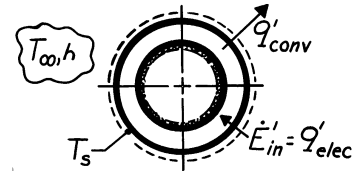

$$\dot{E}'_{in} - \dot{E}'_{out} + \dot{E}'_{gen} = \dot{E}'_{st}$$

$$+q'_{elec} - q'_{conv} = 0.$$

Using Newton's law of cooling,

$$q'_{elec} = q'_{conv} = h \cdot 2\pi r_2 (T_s - T_\infty)$$

$$q'_{elec} = 50 \frac{\text{W}}{\text{m}^2 \cdot \text{K}} \times 2\pi (0.040\text{m}) [5 - (-15)]^\circ\text{C} = 251 \text{ W/m.} \quad <$$

(b) From a control volume about Cylinder A, we recognize that the cylinder must be isothermal, that is,

$$T(0) = T(r_1).$$

Represent Cylinder B by a thermal circuit:

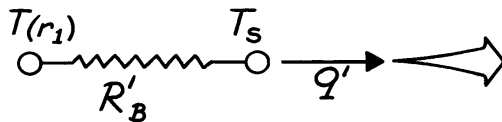

$$q' = \frac{T(r_1) - T_s}{R'_B}$$

For the cylinder, from Eq. 3.28,

$$R'_B = \ln r_2 / r_1 / 2\pi k_B$$

giving

$$T(r_1) = T_s + q'R'_B = 5^\circ\text{C} + 251 \frac{\text{W}}{\text{m}} \frac{\ln 40/20}{2\pi \times 1.5 \text{ W/m} \cdot \text{K}} = 23.5^\circ\text{C}$$

Hence,  $T(0) = T(r_1) = 23.5^\circ\text{C}$ . <

Note that  $k_A$  has no influence on the temperature  $T(0)$ .

### PROBLEM 3.53

**KNOWN:** Electric current and resistance of wire. Wire diameter and emissivity. Thickness, emissivity and thermal conductivity of coating. Temperature of ambient air and surroundings. Expression for heat transfer coefficient at surface of the wire or coating.

**FIND:** (a) Heat generation per unit length and volume of wire, (b) Temperature of uninsulated wire, (c) Inner and outer surface temperatures of insulation, including the effect of insulation thickness.

**SCHEMATIC:**

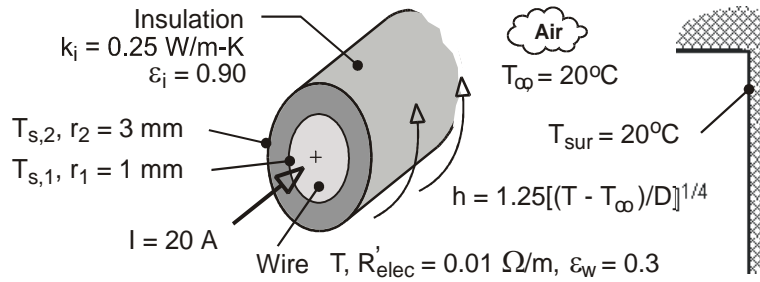

**ASSUMPTIONS:** (1) Steady-state, (2) One-dimensional radial conduction through insulation, (3) Constant properties, (4) Negligible contact resistance between insulation and wire, (5) Negligible radial temperature gradients in wire, (6) Large surroundings.

**ANALYSIS:** (a) The rates of energy generation per unit length and volume are, respectively,

$$\dot{E}'_g = I^2 R'_{elec} = (20 \text{ A})^2 (0.01 \Omega / \text{m}) = 4 \text{ W / m} \quad <$$

$$\dot{q} = \dot{E}'_g / A_c = 4 \dot{E}'_g / \pi D^2 = 16 \text{ W / m} / \pi (0.002 \text{ m})^2 = 1.27 \times 10^6 \text{ W / m}^3 \quad <$$

(b) Without the insulation, an energy balance at the surface of the wire yields

$$\dot{E}'_g = q' = q'_{conv} + q'_{rad} = \pi D h (T - T_\infty) + \pi D \varepsilon_w \sigma (T^4 - T_{sur}^4)$$

where  $h = 1.25[(T - T_\infty)/D]^{1/4}$ . Substituting,

$$4 \text{ W / m} = 1.25\pi (0.002 \text{ m})^{3/4} (T - 293)^{5/4} + \pi (0.002 \text{ m}) 0.3 \times 5.67 \times 10^{-8} \text{ W / m}^2 \cdot \text{K}^4 (T^4 - 293^4) \text{ K}^4$$

and a trial-and-error solution yields

$$T = 331 \text{ K} = 58^\circ \text{C} \quad <$$

(c) Performing an energy balance at the outer surface,

$$\dot{E}'_g = q' = q'_{conv} + q'_{rad} = \pi D h (T_{s,2} - T_\infty) + \pi D \varepsilon_i \sigma (T_{s,2}^4 - T_{sur}^4)$$

$$4 \text{ W / m} = 1.25\pi (0.006 \text{ m})^{3/4} (T_{s,2} - 293)^{5/4} + \pi (0.006 \text{ m}) 0.9 \times 5.67 \times 10^{-8} \text{ W / m}^2 \cdot \text{K}^4 (T_{s,2}^4 - 293^4) \text{ K}^4$$

and an iterative solution yields the following value of the surface temperature

$$T_{s,2} = 307.8 \text{ K} = 34.8^\circ \text{C} \quad <$$

The inner surface temperature may then be obtained from the following expression for heat transfer by conduction in the insulation.

Continued ...

**PROBLEM 3.53 (Cont.)**

$$q' = \frac{T_{s,i} - T_{s,2}}{R'_{\text{cond}}} = \frac{T_{s,i} - T_{s,2}}{\ln(r_2/r_1)/2\pi k_i}$$

$$4 \text{ W} = \frac{2\pi (0.25 \text{ W/m}\cdot\text{K})(T_{s,i} - 307.8 \text{ K})}{\ln(3)}$$

$$T_{s,i} = 310.6 \text{ K} = 37.6^\circ\text{C}$$

<

As shown below, the effect of increasing the insulation thickness is to *reduce*, not increase, the surface temperatures.

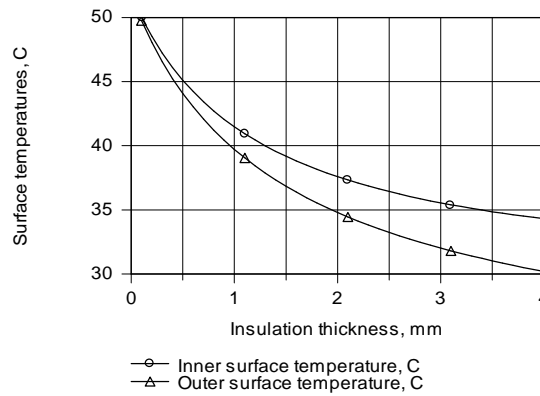

This behavior is due to a reduction in the total resistance to heat transfer with increasing  $r_2$ . Although the convection,  $h$ , and radiation,  $h_r = \varepsilon\sigma(T_{s,2} + T_{\text{sur}})(T_{s,2}^2 + T_{\text{sur}}^2)$ , coefficients decrease with increasing  $r_2$ , the corresponding increase in the surface area is more than sufficient to provide for a reduction in the total resistance. Even for an insulation thickness of  $t = 4 \text{ mm}$ ,  $h = h + h_r = (7.1 + 5.4) \text{ W/m}^2\cdot\text{K} = 12.5 \text{ W/m}^2\cdot\text{K}$ , and  $r_{\text{cr}} = k/h = 0.25 \text{ W/m}\cdot\text{K}/12.5 \text{ W/m}^2\cdot\text{K} = 0.020 \text{ m} = 20 \text{ mm} > r_2 = 5 \text{ mm}$ . The outer radius of the insulation is therefore well below the critical radius.

### PROBLEM 3.54

**KNOWN:** Diameter of electrical wire. Thickness and thermal conductivity of rubberized sheath. Contact resistance between sheath and wire. Convection coefficient and ambient air temperature. Maximum allowable sheath temperature.

**FIND:** Maximum allowable power dissipation per unit length of wire. Critical radius of insulation.

**SCHEMATIC:**

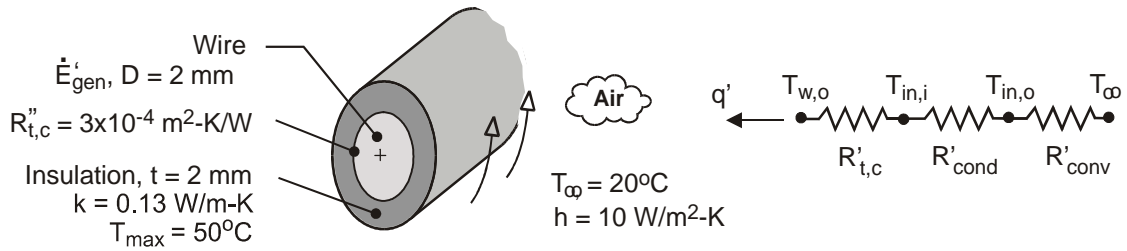

**ASSUMPTIONS:** (1) Steady-state, (2) One-dimensional radial conduction through insulation, (3) Constant properties, (4) Negligible radiation exchange with surroundings.

**ANALYSIS:** The maximum insulation temperature corresponds to its inner surface and is independent of the contact resistance. From the thermal circuit, we may write

$$\dot{E}'_g = q' = \frac{T_{in,i} - T_\infty}{R'_{cond} + R'_{conv}} = \frac{T_{in,i} - T_\infty}{\left[ \ln(r_{in,o} / r_{in,i}) / 2\pi k \right] + (1 / 2\pi r_{in,o} h)}$$

where  $r_{in,i} = D/2 = 0.001\text{m}$ ,  $r_{in,o} = r_{in,i} + t = 0.003\text{m}$ , and  $T_{in,i} = T_{max} = 50^\circ\text{C}$  yields the maximum allowable power dissipation. Hence,

$$\dot{E}'_{g,max} = \frac{(50 - 20)^\circ\text{C}}{\frac{\ln 3}{2\pi \times 0.13 \text{ W/m} \cdot \text{K}} + \frac{1}{2\pi (0.003\text{m}) 10 \text{ W/m}^2 \cdot \text{K}}} = \frac{30^\circ\text{C}}{(1.35 + 5.31) \text{ m} \cdot \text{K} / \text{W}} = 4.51 \text{ W/m} \quad <$$

The critical insulation radius is also unaffected by the contact resistance and is given by

$$r_{cr} = \frac{k}{h} = \frac{0.13 \text{ W/m} \cdot \text{K}}{10 \text{ W/m}^2 \cdot \text{K}} = 0.013\text{m} = 13 \text{ mm} \quad <$$

Hence,  $r_{in,o} < r_{cr}$  and  $\dot{E}'_{g,max}$  could be increased by increasing  $r_{in,o}$  up to a value of 13 mm ( $t = 12$  mm).

**COMMENTS:** The contact resistance affects the temperature of the wire, and for  $q' = \dot{E}'_{g,max} = 4.51 \text{ W/m}$ , the outer surface temperature of the wire is  $T_{w,o} = T_{in,i} + q' R'_{t,c} = 50^\circ\text{C} + (4.51 \text{ W/m}) (3 \times 10^{-4} \text{ m}^2 \cdot \text{K/W}) / \pi (0.002\text{m}) = 50.2^\circ\text{C}$ . Hence, the temperature change across the contact resistance is negligible.



### PROBLEM 3.55

**KNOWN:** Long rod experiencing uniform volumetric generation of thermal energy,  $\dot{q}$ , concentric with a hollow ceramic cylinder creating an enclosure filled with air. Thermal resistance per unit length due to radiation exchange between enclosure surfaces is  $R'_{\text{rad}}$ . The free convection coefficient for the enclosure surfaces is  $h = 20 \text{ W/m}^2 \cdot \text{K}$ .

**FIND:** (a) Thermal circuit of the system that can be used to calculate the surface temperature of the rod,  $T_r$ ; label all temperatures, heat rates and thermal resistances; evaluate the thermal resistances; and (b) Calculate the surface temperature of the rod.

**SCHEMATIC:**

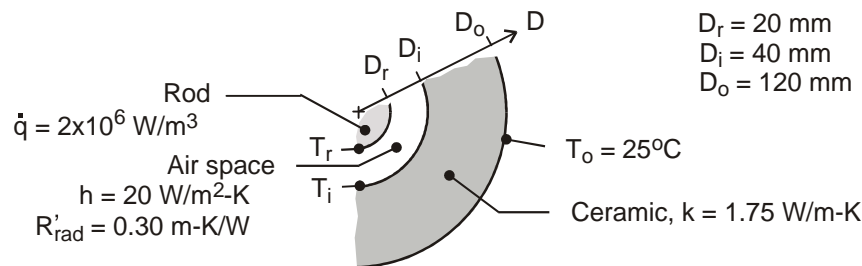

**ASSUMPTIONS:** (1) Steady-state conditions, (2) One-dimensional, radial conduction through the hollow cylinder, (3) The enclosure surfaces experience free convection and radiation exchange.

**ANALYSIS:** (a) The thermal circuit is shown below. Note labels for the temperatures, thermal resistances and the relevant heat fluxes.

*Enclosure, radiation exchange (given):*

$$R'_{\text{rad}} = 0.30 \text{ m} \cdot \text{K} / \text{W}$$

*Enclosure, free convection:*

$$R'_{\text{cv,rod}} = \frac{1}{h\pi D_r} = \frac{1}{20 \text{ W/m}^2 \cdot \text{K} \times \pi \times 0.020 \text{ m}} = 0.80 \text{ m} \cdot \text{K} / \text{W}$$

$$R'_{\text{cv,cer}} = \frac{1}{h\pi D_i} = \frac{1}{20 \text{ W/m}^2 \cdot \text{K} \times \pi \times 0.040 \text{ m}} = 0.40 \text{ m} \cdot \text{K} / \text{W}$$

*Ceramic cylinder, conduction:*

$$R'_{\text{cd}} = \frac{\ln(D_o/D_i)}{2\pi k} = \frac{\ln(0.120/0.040)}{2\pi \times 1.75 \text{ W/m} \cdot \text{K}} = 0.10 \text{ m} \cdot \text{K} / \text{W}$$

The thermal resistance between the enclosure surfaces (r-i) due to convection and radiation exchange is

$$\frac{1}{R'_{\text{enc}}} = \frac{1}{R'_{\text{rad}}} + \frac{1}{R'_{\text{cv,rod}} + R'_{\text{cv,cer}}}$$

$$R'_{\text{enc}} = \left[ \frac{1}{0.30} + \frac{1}{0.80 + 0.40} \right]^{-1} \text{ m} \cdot \text{K} / \text{W} = 0.24 \text{ m} \cdot \text{K} / \text{W}$$

The total resistance between the rod surface (r) and the outer surface of the cylinder (o) is

$$R'_{\text{tot}} = R'_{\text{enc}} + R'_{\text{cd}} = (0.24 + 0.1) \text{ m} \cdot \text{K} / \text{W} = 0.34 \text{ m} \cdot \text{K} / \text{W}$$

Continued ...

**PROBLEM 3.55 (Cont.)**

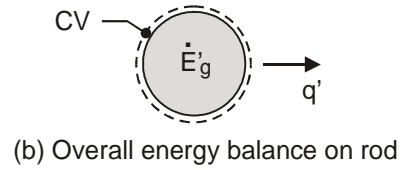
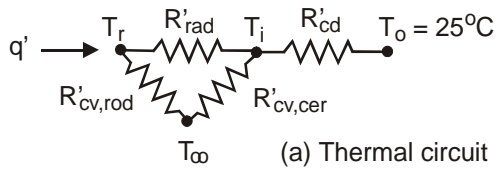

(b) From an energy balance on the rod (see schematic) find  $T_r$ .

$$\dot{E}'_{in} - \dot{E}'_{out} + \dot{E}'_{gen} = 0$$

$$-q + \dot{q}V = 0$$

$$-(T_r - T_i) / R'_{tot} + \dot{q}(\pi D_r^2 / 4) = 0$$

$$-(T_r - 25) \text{K} / 0.34 \text{ m} \cdot \text{K} / \text{W} + 2 \times 10^6 \text{ W} / \text{m}^3 (\pi \times 0.020 \text{ m}^2 / 4) = 0$$

$$T_r = 239^\circ\text{C}$$

<

**COMMENTS:** In evaluating the convection resistance of the air space, it was necessary to define an average air temperature ( $T_\infty$ ) and consider the convection coefficients for each of the space surfaces. As you'll learn later in Chapter 9, correlations are available for directly estimating the convection coefficient ( $h_{enc}$ ) for the enclosure so that  $q_{cv} = h_{enc} (T_r - T_i)$ .

### PROBLEM 3.56

**KNOWN:** Tube diameter and refrigerant temperature for evaporator of a refrigerant system. Convection coefficient and temperature of outside air.

**FIND:** (a) Rate of heat extraction without frost formation, (b) Effect of frost formation on heat rate, (c) Time required for a 2 mm thick frost layer to melt in ambient air for which  $h = 2 \text{ W/m}^2\cdot\text{K}$  and  $T_\infty = 20^\circ\text{C}$ .

**SCHEMATIC:**

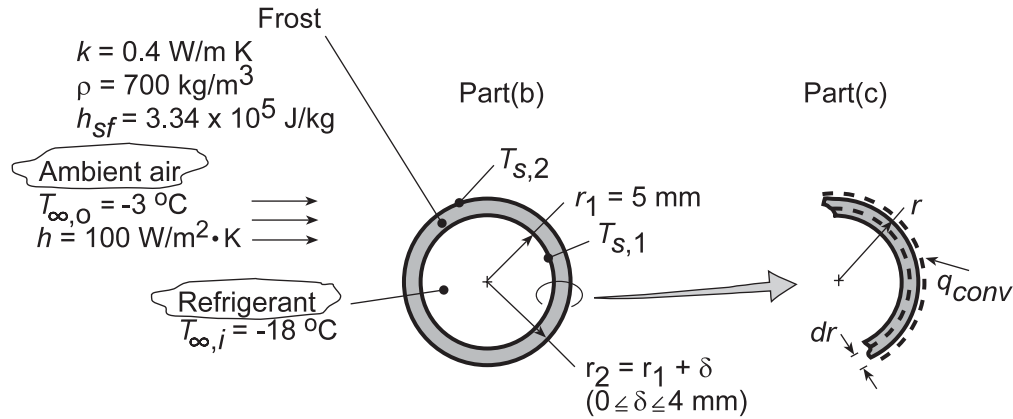

**ASSUMPTIONS:** (1) One-dimensional, steady-state conditions, (2) Negligible convection resistance for refrigerant flow ( $T_{\infty,i} = T_{s,1}$ ), (3) Negligible tube wall conduction resistance, (4) Negligible radiation exchange at outer surface.

**ANALYSIS:** (a) The cooling capacity in the defrosted condition ( $\delta = 0$ ) corresponds to the rate of heat extraction from the airflow. Hence,

$$q' = h2\pi r_1 (T_{\infty,o} - T_{s,1}) = 100 \text{ W/m}^2 \cdot \text{K} (2\pi \times 0.005 \text{ m}) (-3 + 18)^\circ \text{C}$$

$$q' = 47.1 \text{ W/m}$$

(b) With the frost layer, there is an additional (conduction) resistance to heat transfer, and the extraction rate is

$$q' = \frac{T_{\infty,o} - T_{s,1}}{R'_{\text{conv}} + R'_{\text{cond}}} = \frac{T_{\infty,o} - T_{s,1}}{1/(h2\pi r_2) + \ln(r_2/r_1)/2\pi k}$$

For  $5 \leq r_2 \leq 9 \text{ mm}$  and  $k = 0.4 \text{ W/m}\cdot\text{K}$ , this expression yields

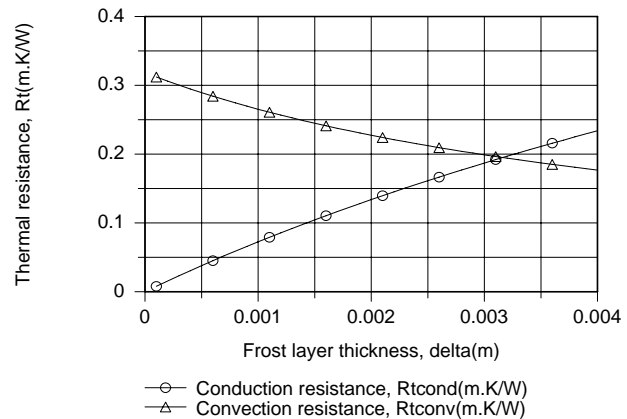
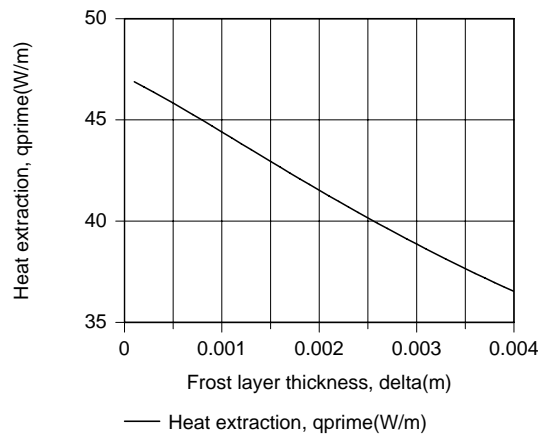

Continued...

### PROBLEM 3.56 (Cont.)

The heat extraction, and hence the performance of the evaporator coil, decreases with increasing frost layer thickness due to an increase in the total resistance to heat transfer. Although the convection resistance decreases with increasing  $\delta$ , the reduction is exceeded by the increase in the conduction resistance.

(c) The time  $t_m$  required to melt a 2 mm thick frost layer may be determined by applying an energy balance, Eq. 1.12c, over the differential time interval  $dt$  and to a differential control volume extending inward from the surface of the layer.

$$\dot{E}_{in} dt = dE_{st} = dU_{lat}$$

$$h(2\pi rL)(T_{\infty,o} - T_f) dt = -h_{sf} \rho dV = -h_{sf} \rho (2\pi rL) dr$$

$$h(T_{\infty,o} - T_f) \int_0^{t_m} dt = -\rho h_{sf} \int_{r_2}^{r_1} dr$$

$$t_m = \frac{\rho h_{sf} (r_2 - r_1)}{h(T_{\infty,o} - T_f)} = \frac{700 \text{ kg/m}^3 (3.34 \times 10^5 \text{ J/kg})(0.002 \text{ m})}{2 \text{ W/m}^2 \cdot \text{K} (20 - 0)^\circ \text{C}}$$

$$t_m = 11,690 \text{ s} = 3.25 \text{ h}$$

<

**COMMENTS:** The tube radius  $r_1$  exceeds the critical radius  $r_{cr} = k/h = 0.4 \text{ W/m}\cdot\text{K}/100 \text{ W/m}^2\cdot\text{K} = 0.004 \text{ m}$ , in which case any frost formation will reduce the performance of the coil.

### PROBLEM 3.57

**KNOWN:** Conditions associated with a composite wall and a thin electric heater.

**FIND:** (a) Equivalent thermal circuit, (b) Expression for heater temperature, (c) Ratio of outer and inner heat flows and conditions for which ratio is minimized.

**SCHEMATIC:**

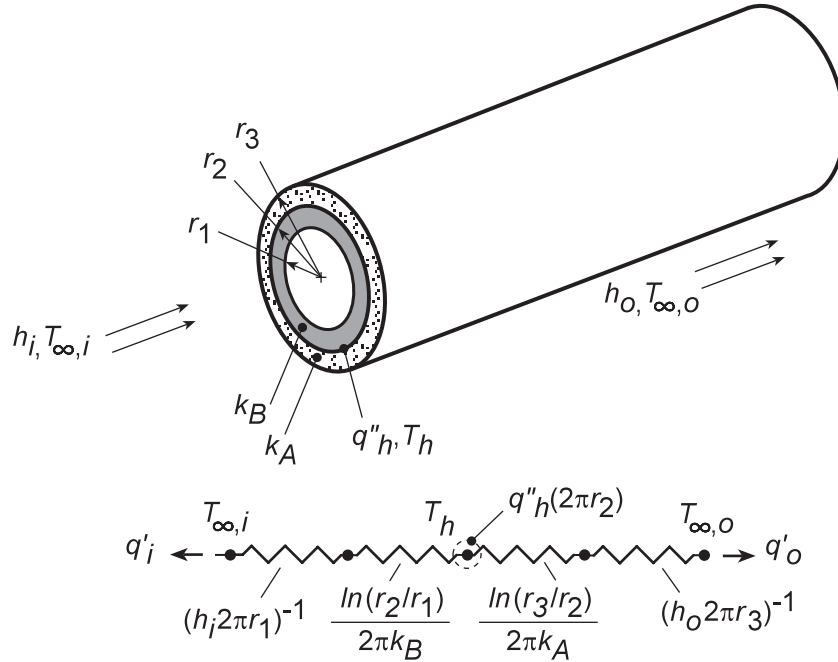

**ASSUMPTIONS:** (1) One-dimensional, steady-state conduction, (2) Constant properties, (3) Isothermal heater, (4) Negligible contact resistance(s).

**ANALYSIS:** (a) On the basis of a unit axial length, the circuit, thermal resistances, and heat rates are as shown in the schematic.

(b) Performing an energy balance for the heater,  $\dot{E}_{in} = \dot{E}_{out}$ , it follows that

$$q''_h (2\pi r_2) = q'_i + q'_o = \frac{T_h - T_{\infty,i}}{(h_i 2\pi r_1)^{-1} + \frac{\ln(r_2/r_1)}{2\pi k_B}} + \frac{T_h - T_{\infty,o}}{(h_o 2\pi r_3)^{-1} + \frac{\ln(r_3/r_2)}{2\pi k_A}} \quad <$$

(c) From the circuit,

$$\frac{q'_o}{q'_i} = \frac{(T_h - T_{\infty,o})}{(T_h - T_{\infty,i})} \times \frac{(h_i 2\pi r_1)^{-1} + \frac{\ln(r_2/r_1)}{2\pi k_B}}{(h_o 2\pi r_3)^{-1} + \frac{\ln(r_3/r_2)}{2\pi k_A}} \quad <$$

To reduce  $q'_o/q'_i$ , one could increase  $k_B$ ,  $h_i$ , and  $r_3/r_2$ , while reducing  $k_A$ ,  $h_o$  and  $r_2/r_1$ .

**COMMENTS:** Contact resistances between the heater and materials A and B could be important.

### PROBLEM 3.58

**KNOWN:** Electric current flow, resistance, diameter and environmental conditions associated with a cable.

**FIND:** (a) Surface temperature of bare cable, (b) Cable surface and insulation temperatures for a thin coating of insulation, (c) Insulation thickness which provides the lowest value of the maximum insulation temperature. Corresponding value of this temperature.

**SCHEMATIC:**

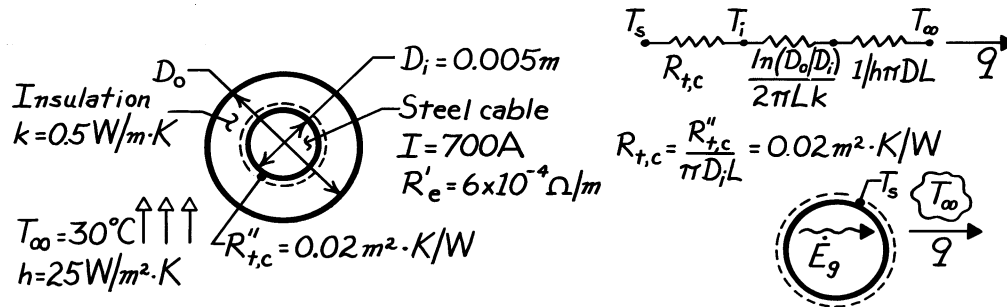

**ASSUMPTIONS:** (1) Steady-state conditions, (2) One-dimensional conduction in  $r$ , (3) Constant properties.

**ANALYSIS:** (a) The rate at which heat is transferred to the surroundings is fixed by the rate of heat generation in the cable. Performing an energy balance for a control surface about the cable, it follows that  $\dot{E}_g = q$  or, for the bare cable,  $I^2 R'_e L = h(\pi D_i L)(T_s - T_\infty)$ . With  $q' = I^2 R'_e = (700 \text{ A})^2 (6 \times 10^{-4} \Omega/\text{m}) = 294 \text{ W/m}$ , it follows that

$$T_s = T_\infty + \frac{q'}{h\pi D_i} = 30^\circ \text{C} + \frac{294 \text{ W/m}}{(25 \text{ W/m}^2 \cdot \text{K})\pi(0.005 \text{ m})}$$

$$T_s = 778.7^\circ \text{C} \quad <$$

(b) With a thin coating of insulation, there exist contact and convection resistances to heat transfer from the cable. The heat transfer rate is determined by heating within the cable, however, and therefore remains the same.

$$q = \frac{T_s - T_\infty}{R_{t,c} + \frac{1}{h\pi D_i L}} = \frac{T_s - T_\infty}{\frac{R''_{t,c}}{\pi D_i L} + \frac{1}{h\pi D_i L}}$$

$$q' = \frac{\pi D_i (T_s - T_\infty)}{R''_{t,c} + 1/h}$$

and solving for the surface temperature, find

$$T_s = \frac{q'}{\pi D_i} \left[ R''_{t,c} + \frac{1}{h} \right] + T_\infty = \frac{294 \text{ W/m}}{\pi(0.005 \text{ m})} \left[ 0.02 \frac{\text{m}^2 \cdot \text{K}}{\text{W}} + 0.04 \frac{\text{m}^2 \cdot \text{K}}{\text{W}} \right] + 30^\circ \text{C}$$

$$T_s = 1153^\circ \text{C} \quad <$$

Continued ...

**PROBLEM 3.58 (Cont.)**

The insulation temperature is then obtained from

$$q = \frac{T_s - T_i}{R_{t,c}}$$

or

$$T_i = T_s - qR_{t,c} = 1153^\circ\text{C} - q \frac{R''_{t,c}}{\pi D_i L} = 1153^\circ\text{C} - \frac{294 \frac{\text{W}}{\text{m}} \times 0.02 \frac{\text{m}^2 \cdot \text{K}}{\text{W}}}{\pi (0.005\text{m})}$$

$$T_i = 778.7^\circ\text{C}.$$

<

(c) The maximum insulation temperature could be reduced by reducing the resistance to heat transfer from the outer surface of the insulation. Such a reduction is possible if  $D_i < D_{cr}$ . From Example 3.6,

$$r_{cr} = \frac{k}{h} = \frac{0.5 \text{ W/m} \cdot \text{K}}{25 \text{ W/m}^2 \cdot \text{K}} = 0.02\text{m}.$$

Hence,  $D_{cr} = 0.04\text{m} > D_i = 0.005\text{m}$ . To minimize the maximum temperature, which exists at the inner surface of the insulation, add insulation in the amount

$$t = \frac{D_o - D_i}{2} = \frac{D_{cr} - D_i}{2} = \frac{(0.04 - 0.005)\text{m}}{2}$$

$$t = 0.0175\text{m}.$$

<

The cable surface temperature may then be obtained from

$$q' = \frac{T_s - T_\infty}{\frac{R''_{t,c}}{\pi D_i} + \frac{\ln(D_{cr}/D_i)}{2\pi k} + \frac{1}{h\pi D_{cr}}} = \frac{T_s - 30^\circ\text{C}}{\frac{0.02 \text{ m}^2 \cdot \text{K/W}}{\pi (0.005\text{m})} + \frac{\ln(0.04/0.005)}{2\pi (0.5 \text{ W/m} \cdot \text{K})} + \frac{1}{25 \frac{\text{W}}{\text{m}^2 \cdot \text{K}} \pi (0.04\text{m})}}$$

Hence,

$$294 \frac{\text{W}}{\text{m}} = \frac{T_s - 30^\circ\text{C}}{(1.27 + 0.66 + 0.32)\text{m} \cdot \text{K/W}} = \frac{T_s - 30^\circ\text{C}}{2.25 \text{ m} \cdot \text{K/W}}$$

$$T_s = 692.5^\circ\text{C}$$

Recognizing that  $q = (T_s - T_i)/R_{t,c}$ , find

$$T_i = T_s - qR_{t,c} = T_s - q \frac{R''_{t,c}}{\pi D_i L} = 692.5^\circ\text{C} - \frac{294 \frac{\text{W}}{\text{m}} \times 0.02 \frac{\text{m}^2 \cdot \text{K}}{\text{W}}}{\pi (0.005\text{m})}$$

$$T_i = 318.2^\circ\text{C}.$$

<

**COMMENTS:** Use of the critical insulation thickness in lieu of a thin coating has the effect of reducing the maximum insulation temperature from  $778.7^\circ\text{C}$  to  $318.2^\circ\text{C}$ . Use of the critical insulation thickness also reduces the cable surface temperature to  $692.5^\circ\text{C}$  from  $778.7^\circ\text{C}$  with no insulation or from  $1153^\circ\text{C}$  with a thin coating.

### PROBLEM 3.59

**KNOWN:** Saturated steam conditions in a pipe with prescribed surroundings.

**FIND:** (a) Heat loss per unit length from bare pipe and from insulated pipe, (b) Pay back period for insulation.

**SCHEMATIC:**

Steam Costs:  
\$4 for  $10^9$  J  
Insulation Cost:  
\$100 per meter  
Operation time:  
7500 h/yr

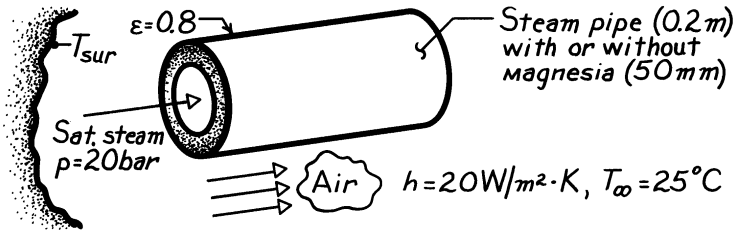

**ASSUMPTIONS:** (1) Steady-state conditions, (2) One-dimensional heat transfer, (3) Constant properties, (4) Negligible pipe wall resistance, (5) Negligible steam side convection resistance (pipe inner surface temperature is equal to steam temperature), (6) Negligible contact resistance, (7)  $T_{sur} = T_{\infty}$ .

**PROPERTIES:** Table A-6, Saturated water ( $p = 20$  bar):  $T_{sat} = T_s = 486\text{K}$ ; Table A-3, Magnesia, 85% ( $T \approx 392\text{K}$ ):  $k = 0.058$  W/m·K.

**ANALYSIS:** (a) Without the insulation, the heat loss may be expressed in terms of radiation and convection rates,

$$q' = \varepsilon \pi D \sigma (T_s^4 - T_{sur}^4) + h(\pi D)(T_s - T_{\infty})$$

$$q' = 0.8 \pi (0.2\text{m}) 5.67 \times 10^{-8} \frac{\text{W}}{\text{m}^2 \cdot \text{K}^4} (486^4 - 298^4) \text{K}^4$$

$$+ 20 \frac{\text{W}}{\text{m}^2 \cdot \text{K}} (\pi \times 0.2\text{m}) (486 - 298) \text{K}$$

$$q' = (1365 + 2362) \text{W/m} = 3727 \text{W/m.} \quad <$$

With the insulation, the thermal circuit is of the form

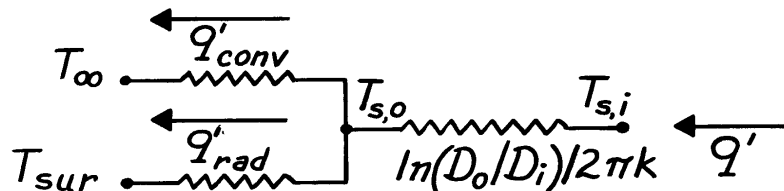

Continued ...



**PROBLEM 3.59 (Cont.)**

From an energy balance at the outer surface of the insulation,

$$q'_{\text{cond}} = q'_{\text{conv}} + q'_{\text{rad}}$$

$$\frac{T_{s,i} - T_{s,o}}{\ln(D_o/D_i)/2\pi k} = h\pi D_o (T_{s,o} - T_\infty) + \varepsilon\sigma\pi D_o (T_{s,o}^4 - T_{\text{sur}}^4)$$

$$\frac{(486 - T_{s,o})\text{K}}{\ln(0.3\text{m}/0.2\text{m})} = 20 \frac{\text{W}}{\text{m}^2 \cdot \text{K}} \pi (0.3\text{m}) (T_{s,o} - 298\text{K})$$

$$\frac{2\pi (0.058 \text{ W/m} \cdot \text{K})}{+0.8 \times 5.67 \times 10^{-8} \frac{\text{W}}{\text{m}^2 \cdot \text{K}^4} \pi (0.3\text{m}) (T_{s,o}^4 - 298^4) \text{K}^4}$$

By trial and error, we obtain

$$T_{s,o} \approx 305\text{K}$$

in which case

$$q' = \frac{(486 - 305)\text{K}}{\ln(0.3\text{m}/0.2\text{m})} = 163 \text{ W/m.} \quad <$$

$$\frac{2\pi (0.055 \text{ W/m} \cdot \text{K})}$$

(b) The yearly energy savings per unit length of pipe due to use of the insulation is

$$\frac{\text{Savings}}{\text{Yr} \cdot \text{m}} = \frac{\text{Energy Savings}}{\text{Yr.}} \times \frac{\text{Cost}}{\text{Energy}}$$

$$\frac{\text{Savings}}{\text{Yr} \cdot \text{m}} = (3727 - 163) \frac{\text{J}}{\text{s} \cdot \text{m}} \times 3600 \frac{\text{s}}{\text{h}} \times 7500 \frac{\text{h}}{\text{Yr}} \times \frac{\$4}{10^9 \text{J}}$$

$$\frac{\text{Savings}}{\text{Yr} \cdot \text{m}} = \$385 / \text{Yr} \cdot \text{m.}$$

The pay back period is then

$$\text{Pay Back Period} = \frac{\text{Insulation Costs}}{\text{Savings/Yr} \cdot \text{m}} = \frac{\$100/\text{m}}{\$385/\text{Yr} \cdot \text{m}}$$

$$\text{Pay Back Period} = 0.26 \text{ Yr} = 3.1 \text{ mo.} \quad <$$

**COMMENTS:** Such a low pay back period is more than sufficient to justify investing in the insulation.

### PROBLEM 3.60

**KNOWN:** Pipe wall temperature and convection conditions associated with water flow through the pipe and ice layer formation on the inner surface.

**FIND:** Ice layer thickness  $\delta$ .

**SCHEMATIC:**

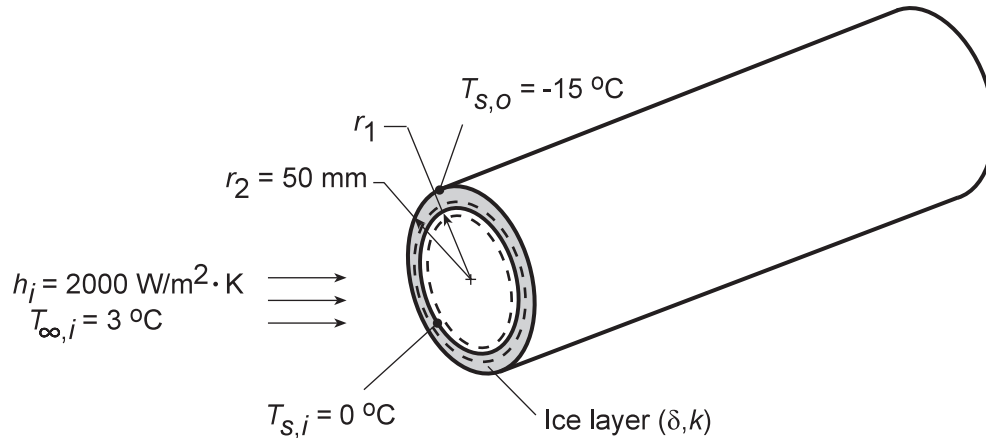

**ASSUMPTIONS:** (1) One-dimensional, steady-state conduction, (2) Negligible pipe wall thermal resistance, (3) negligible ice/wall contact resistance, (4) Constant  $k$ .

**PROPERTIES:** Table A.3, Ice ( $T = 265$  K):  $k \approx 1.94$  W/m·K.

**ANALYSIS:** Performing an energy balance for a control surface about the ice/water interface, it follows that, for a unit length of pipe,

$$q'_{\text{conv}} = q'_{\text{cond}}$$

$$h_i (2\pi r_1) (T_{\infty,i} - T_{s,i}) = \frac{T_{s,i} - T_{s,o}}{\ln(r_2/r_1)/2\pi k}$$

Dividing both sides of the equation by  $r_2$ ,

$$\frac{\ln(r_2/r_1)}{(r_2/r_1)} = \frac{k}{h_i r_2} \times \frac{T_{s,i} - T_{s,o}}{T_{\infty,i} - T_{s,i}} = \frac{1.94 \text{ W/m} \cdot \text{K}}{(2000 \text{ W/m}^2 \cdot \text{K})(0.05 \text{ m})} \times \frac{15^\circ \text{C}}{3^\circ \text{C}} = 0.097$$

The equation is satisfied by  $r_2/r_1 = 1.114$ , in which case  $r_1 = 0.050 \text{ m}/1.114 = 0.045 \text{ m}$ , and the ice layer thickness is

$$\delta = r_2 - r_1 = 0.005 \text{ m} = 5 \text{ mm} \quad \blacktriangleleft$$

**COMMENTS:** With no flow,  $h_i \rightarrow 0$ , in which case  $r_1 \rightarrow 0$  and complete blockage could occur. The pipe should be insulated.

### PROBLEM 3.61

**KNOWN:** Inner surface temperature of insulation blanket comprised of two semi-cylindrical shells of different materials. Ambient air conditions.

**FIND:** (a) Equivalent thermal circuit, (b) Total heat loss and material outer surface temperatures.

**SCHEMATIC:**

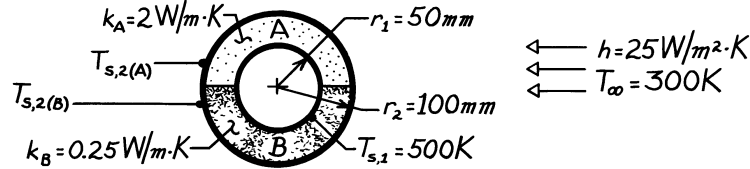

**ASSUMPTIONS:** (1) Steady-state conditions, (2) One-dimensional, radial conduction, (3) Infinite contact resistance between materials, (4) Constant properties.

**ANALYSIS:** (a) The thermal circuit is,

$$R'_{\text{conv},A} = R'_{\text{conv},B} = 1/\pi r_2 h$$

$$R'_{\text{cond}}(A) = \frac{\ln(r_2/r_1)}{\pi k_A}$$

$$R'_{\text{cond}}(B) = \frac{\ln(r_2/r_1)}{\pi k_B}$$

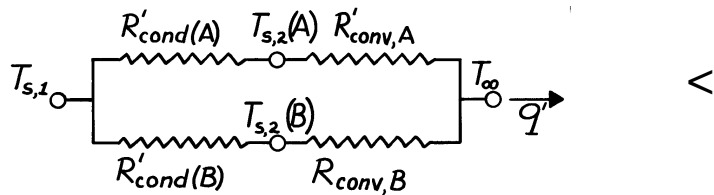

The conduction resistances follow from Section 3.3.1 and Eq. 3.33. Each resistance is larger by a factor of 2 than the result of Eq. 3.28 due to the reduced area.

(b) Evaluating the thermal resistances and the heat rate ( $q' = q'_A + q'_B$ ),

$$R'_{\text{conv}} = \left( \pi \times 0.1 \text{ m} \times 25 \text{ W/m}^2 \cdot \text{K} \right)^{-1} = 0.1273 \text{ m} \cdot \text{K/W}$$

$$R'_{\text{cond}}(A) = \frac{\ln(0.1 \text{ m}/0.05 \text{ m})}{\pi \times 2 \text{ W/m} \cdot \text{K}} = 0.1103 \text{ m} \cdot \text{K/W} \quad R'_{\text{cond}}(B) = 8 R'_{\text{cond}}(A) = 0.8825 \text{ m} \cdot \text{K/W}$$

$$q' = \frac{T_{s,1} - T_\infty}{R'_{\text{cond}}(A) + R'_{\text{conv}}} + \frac{T_{s,1} - T_\infty}{R'_{\text{cond}}(B) + R'_{\text{conv}}}$$

$$q' = \frac{(500 - 300) \text{ K}}{(0.1103 + 0.1273) \text{ m} \cdot \text{K/W}} + \frac{(500 - 300) \text{ K}}{(0.8825 + 0.1273) \text{ m} \cdot \text{K/W}} = (842 + 198) \text{ W/m} = 1040 \text{ W/m.} \quad <$$

Hence, the temperatures are

$$T_{s,2(A)} = T_{s,1} - q'_A R'_{\text{cond}}(A) = 500 \text{ K} - 842 \frac{\text{W}}{\text{m}} \times 0.1103 \frac{\text{m} \cdot \text{K}}{\text{W}} = 407 \text{ K} \quad <$$

$$T_{s,2(B)} = T_{s,1} - q'_B R'_{\text{cond}}(B) = 500 \text{ K} - 198 \frac{\text{W}}{\text{m}} \times 0.8825 \frac{\text{m} \cdot \text{K}}{\text{W}} = 325 \text{ K.} \quad <$$

**COMMENTS:** The total heat loss can also be computed from  $q' = (T_{s,1} - T_\infty)/R_{\text{equiv}}$ ,

$$\text{where } R_{\text{equiv}} = \left[ \left( R'_{\text{cond}}(A) + R'_{\text{conv},A} \right)^{-1} + \left( R'_{\text{cond}}(B) + R'_{\text{conv},B} \right)^{-1} \right]^{-1} = 0.1923 \text{ m} \cdot \text{K/W.}$$

Hence  $q' = (500 - 300) \text{ K}/0.1923 \text{ m} \cdot \text{K/W} = 1040 \text{ W/m.}$

### PROBLEM 3.62

**KNOWN:** Surface temperature of a circular rod coated with Bakelite and adjoining fluid conditions.

**FIND:** (a) Critical insulation radius, (b) Heat transfer per unit length for bare rod and for insulation at critical radius, (c) Insulation thickness needed for 25% heat rate reduction.

**SCHEMATIC:**

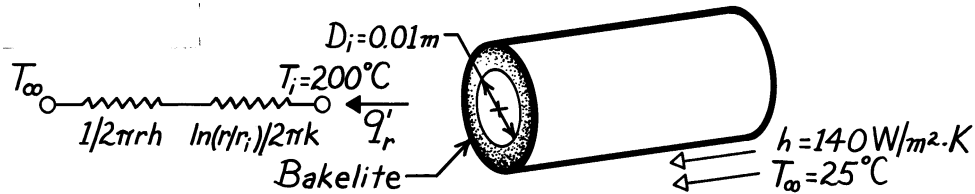

**ASSUMPTIONS:** (1) Steady-state conditions, (2) One-dimensional conduction in  $r$ , (3) Constant properties, (4) Negligible radiation and contact resistance.

**PROPERTIES:** Table A-3, Bakelite (300K):  $k = 1.4 \text{ W/m}\cdot\text{K}$ .

**ANALYSIS:** (a) From Example 3.6, the critical radius is

$$r_{\text{cr}} = \frac{k}{h} = \frac{1.4 \text{ W/m}\cdot\text{K}}{140 \text{ W/m}^2\cdot\text{K}} = 0.01 \text{ m.} \quad <$$

(b) For the bare rod,

$$q' = h(\pi D_i) (T_i - T_\infty)$$

$$q' = 140 \frac{\text{W}}{\text{m}^2\cdot\text{K}} (\pi \times 0.01 \text{ m}) (200 - 25)^\circ \text{C} = 770 \text{ W/m} \quad <$$

For the critical insulation thickness,

$$q' = \frac{T_i - T_\infty}{\frac{1}{2\pi r_{\text{cr}} h} + \frac{\ln(r_{\text{cr}}/r_i)}{2\pi k}} = \frac{(200 - 25)^\circ \text{C}}{\frac{1}{2\pi \times (0.01 \text{ m}) \times 140 \text{ W/m}^2\cdot\text{K}} + \frac{\ln(0.01 \text{ m}/0.005 \text{ m})}{2\pi \times 1.4 \text{ W/m}\cdot\text{K}}}$$

$$q' = \frac{175^\circ \text{C}}{(0.1137 + 0.0788) \text{ m}\cdot\text{K/W}} = 909 \text{ W/m} \quad <$$

(c) The insulation thickness needed to reduce the heat rate to 577 W/m is obtained from

$$q' = \frac{T_i - T_\infty}{\frac{1}{2\pi r h} + \frac{\ln(r/r_i)}{2\pi k}} = \frac{(200 - 25)^\circ \text{C}}{\frac{1}{2\pi (r) 140 \text{ W/m}^2\cdot\text{K}} + \frac{\ln(r/0.005 \text{ m})}{2\pi \times 1.4 \text{ W/m}\cdot\text{K}}} = 577 \frac{\text{W}}{\text{m}}$$

From a trial-and-error solution, find

$$r \approx 0.06 \text{ m.}$$

The desired insulation thickness is then

$$\delta = (r - r_i) \approx (0.06 - 0.005) \text{ m} = 55 \text{ mm.} \quad <$$

### PROBLEM 3.63

**KNOWN:** Geometry of an oil storage tank. Temperature of stored oil and environmental conditions.

**FIND:** Heater power required to maintain a prescribed inner surface temperature.

**SCHEMATIC:**

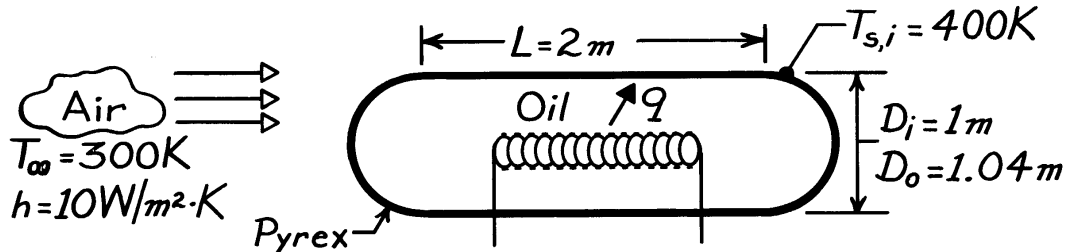

**ASSUMPTIONS:** (1) Steady-state conditions, (2) One-dimensional conduction in radial direction, (3) Constant properties, (4) Negligible radiation.

**PROPERTIES:** Table A-3, Pyrex (300K):  $k = 1.4 \text{ W/m}\cdot\text{K}$ .

**ANALYSIS:** The rate at which heat must be supplied is equal to the loss through the cylindrical and hemispherical sections. Hence,

$$q = q_{\text{cyl}} + 2q_{\text{hemi}} = q_{\text{cyl}} + q_{\text{spher}}$$

or, from Eqs. 3.33 and 3.41,

$$q = \frac{T_{s,i} - T_{\infty}}{\frac{\ln(D_o/D_i)}{2\pi Lk} + \frac{1}{\pi D_o L h}} + \frac{T_{s,i} - T_{\infty}}{\frac{1}{2\pi k} \left[ \frac{1}{D_i} - \frac{1}{D_o} \right] + \frac{1}{\pi D_o^2 h}}$$

$$q = \frac{(400 - 300) \text{ K}}{\frac{\ln 1.04}{2\pi (2\text{ m}) 1.4 \text{ W/m}\cdot\text{K}} + \frac{1}{\pi (1.04\text{ m}) 2\text{ m} (10 \text{ W/m}^2 \cdot \text{K})}} + \frac{(400 - 300) \text{ K}}{\frac{1}{2\pi (1.4 \text{ W/m}\cdot\text{K})} (1 - 0.962) \text{ m}^{-1} + \frac{1}{\pi (1.04\text{ m})^2 10 \text{ W/m}^2 \cdot \text{K}}}$$

$$q = \frac{100 \text{ K}}{2.23 \times 10^{-3} \text{ K/W} + 15.30 \times 10^{-3} \text{ K/W}} + \frac{100 \text{ K}}{4.32 \times 10^{-3} \text{ K/W} + 29.43 \times 10^{-3}}$$

$$q = 5705 \text{ W} + 2963 \text{ W} = 8668 \text{ W}.$$

<

### PROBLEM 3.64

**KNOWN:** Diameter of a spherical container used to store liquid oxygen and properties of insulating material. Environmental conditions.

**FIND:** (a) Reduction in evaporative oxygen loss associated with a prescribed insulation thickness, (b) Effect of insulation thickness on evaporation rate.

**SCHEMATIC:**

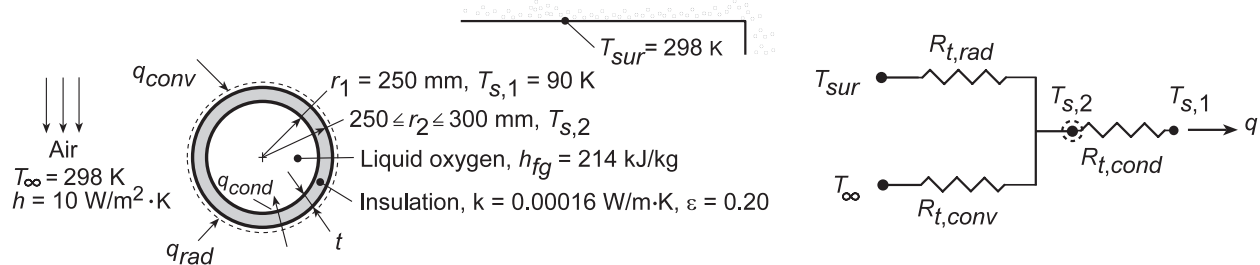

**ASSUMPTIONS:** (1) Steady-state, one-dimensional conduction, (2) Negligible conduction resistance of container wall and contact resistance between wall and insulation, (3) Container wall at boiling point of liquid oxygen.

**ANALYSIS:** (a) Applying an energy balance to a control surface about the insulation,  $\dot{E}_{in} - \dot{E}_{out} = 0$ , it follows that  $q_{conv} + q_{rad} = q_{cond} = q$ . Hence,

$$\frac{T_{\infty} - T_{s,2}}{R_{t,conv}} + \frac{T_{sur} - T_{s,2}}{R_{t,rad}} = \frac{T_{s,2} - T_{s,1}}{R_{t,cond}} = q \quad (1)$$

where  $R_{t,conv} = (4\pi r_2^2 h)^{-1}$ ,  $R_{t,rad} = (4\pi r_2^2 h_r)^{-1}$ ,  $R_{t,cond} = (1/4\pi k)[(1/r_1) - (1/r_2)]$ , and, from Eq.

1.9, the radiation coefficient is  $h_r = \varepsilon \sigma (T_{s,2} + T_{sur})(T_{s,2}^2 + T_{sur}^2)$ . With  $t = 10$  mm ( $r_2 = 260$  mm),  $\varepsilon = 0.2$  and  $T_{\infty} = T_{sur} = 298$  K, an iterative solution of the energy balance equation yields  $T_{s,2} \approx 297.7$  K, where  $R_{t,conv} = 0.118$  K/W,  $R_{t,rad} = 0.982$  K/W and  $R_{t,cond} = 76.5$  K/W. With the insulation, it follows that the heat gain is

$$q_w \approx 2.72 \text{ W}$$

Without the insulation, the heat gain is

$$q_{wo} = \frac{T_{\infty} - T_{s,1}}{R_{t,conv}} + \frac{T_{sur} - T_{s,1}}{R_{t,rad}}$$

where, with  $r_2 = r_1$ ,  $T_{s,1} = 90$  K,  $R_{t,conv} = 0.127$  K/W and  $R_{t,rad} = 3.14$  K/W. Hence,

$$q_{wo} = 1702 \text{ W}$$

With the oxygen mass evaporation rate given by  $\dot{m} = q/h_{fg}$ , the percent reduction in evaporated oxygen is

$$\% \text{ Reduction} = \frac{\dot{m}_{wo} - \dot{m}_w}{\dot{m}_{wo}} \times 100\% = \frac{q_{wo} - q_w}{q_{wo}} \times 100\%$$

Hence,

$$\% \text{ Reduction} = \frac{(1702 - 2.7) \text{ W}}{1702 \text{ W}} \times 100\% = 99.8\%$$

<

Continued...

### PROBLEM 3.64 (Cont.)

(b) Using Equation (1) to compute  $T_{s,2}$  and  $q$  as a function of  $r_2$ , the corresponding evaporation rate,  $\dot{m} = q/h_{fg}$ , may be determined. Variations of  $q$  and  $\dot{m}$  with  $r_2$  are plotted as follows.

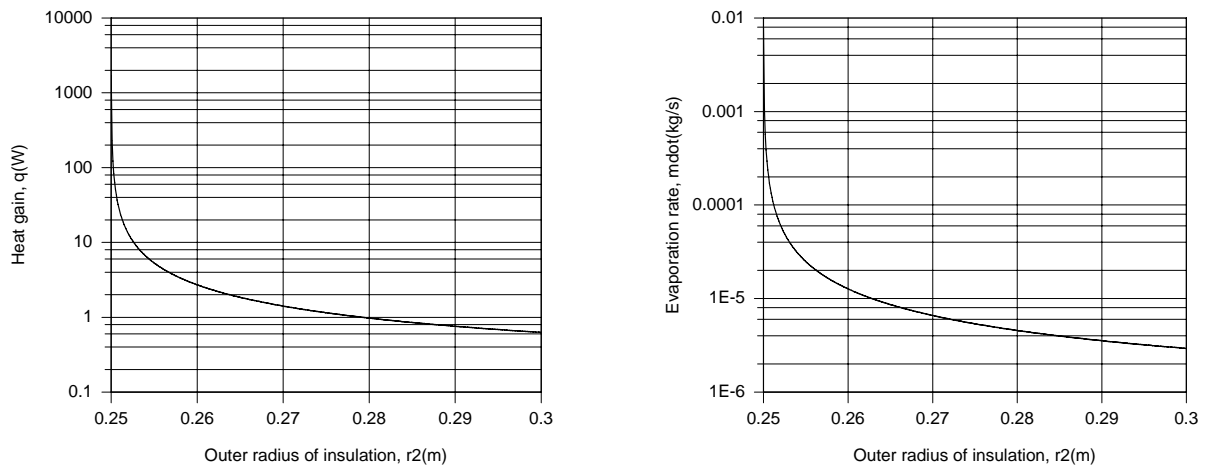

Because of its extremely low thermal conductivity, significant benefits are associated with using even a thin layer of insulation. Nearly three-order magnitude reductions in  $q$  and  $\dot{m}$  are achieved with  $r_2 = 0.26$  m. With increasing  $r_2$ ,  $q$  and  $\dot{m}$  decrease from values of 1702 W and  $8 \times 10^{-3}$  kg/s at  $r_2 = 0.25$  m to 0.627 W and  $2.9 \times 10^{-6}$  kg/s at  $r_2 = 0.30$  m.

**COMMENTS:** Laminated metallic-foil/glass-mat insulations are extremely effective and corresponding conduction resistances are typically much larger than those normally associated with surface convection and radiation.

### PROBLEM 3.65

**KNOWN:** Dimensions and surface temperatures of a glass or aluminum spherical shell.

**FIND:** (a) Mid-point temperature within the shell for a glass shell, (b) Mid-point temperature within the shell for an aluminum shell.

**SCHEMATIC:**

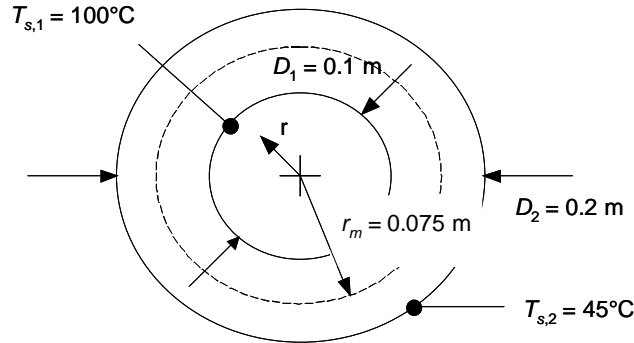

**ASSUMPTIONS:** (1) Steady-state conditions, (2) Constant properties, (3) One-dimensional heat transfer, (4) No internal energy generation within the shell.

**ANALYSIS:** (a) The conduction heat rate into the dashed control surface must equal the conduction heat rate out of the dashed control surface. Hence, from Eq. 3.40

$$q_r = \frac{4\pi k (T_{s,1} - T(r_m))}{(1/r_1) - (1/r_m)} = \frac{4\pi k (T(r_m) - T_{s,2})}{(1/r_m) - (1/r_2)}$$

or,

$$\begin{aligned} T(r_m) &= \frac{1}{\left(\frac{1}{(1/r_m) - (1/r_2)}\right) + \left(\frac{1}{(1/r_1) - (1/r_m)}\right)} \left( \frac{T_{s,1}}{(1/r_1) - (1/r_m)} + \frac{T_{s,2}}{(1/r_m) - (1/r_2)} \right) \\ &= \frac{1}{\left(\frac{1}{(1/0.075\text{m}) - (1/0.1\text{m})}\right) + \left(\frac{1}{(1/0.05\text{m}) - (1/0.075\text{m})}\right)} \times \\ &\quad \left( \frac{100^\circ\text{C}}{(1/0.05\text{m}) - (1/0.075\text{m})} + \frac{45^\circ\text{C}}{(1/0.075\text{m}) - (1/0.1\text{m})} \right) \\ &= 63.3^\circ\text{C} \end{aligned}$$

(b) The temperature distribution is independent of the shell material. Hence,  $T(r_m) = 63.3^\circ\text{C}$

**COMMENTS:** (1) The temperature distribution is not linear. Assuming a linear distribution would be a serious error. (2) The conduction heat rate through the sphere will be much higher for the aluminum shell since the thermal conductivity of aluminum is much greater than that of glass.



### PROBLEM 3.66

**KNOWN:** Sphere of radius  $r_i$ , covered with insulation whose outer surface is exposed to a convection process.

**FIND:** Critical insulation radius,  $r_{cr}$ .

**SCHEMATIC:**

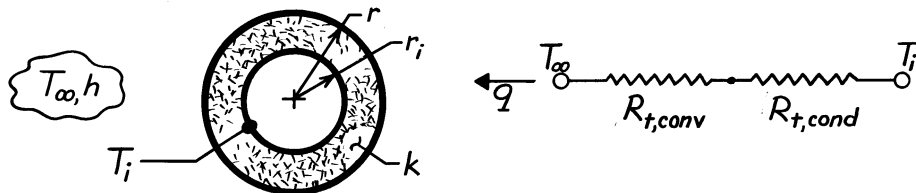

**ASSUMPTIONS:** (1) Steady-state conditions, (2) One-dimensional radial (spherical) conduction, (3) Constant properties, (4) Negligible radiation at surface.

**ANALYSIS:** The heat rate follows from the thermal circuit shown in the schematic,

$$q = (T_i - T_\infty) / R_{tot}$$

where  $R_{tot} = R_{t,conv} + R_{t,cond}$  and

$$R_{t,conv} = \frac{1}{hA_s} = \frac{1}{4\pi hr^2} \quad (3.9)$$

$$R_{t,cond} = \frac{1}{4\pi k} \left[ \frac{1}{r_i} - \frac{1}{r} \right] \quad (3.36)$$

If  $q$  is a maximum or minimum, we need to find the condition for which

$$\frac{dR_{tot}}{dr} = 0.$$

It follows that

$$\frac{d}{dr} \left[ \frac{1}{4\pi k} \left[ \frac{1}{r_i} - \frac{1}{r} \right] + \frac{1}{4\pi hr^2} \right] = \left[ +\frac{1}{4\pi k} \frac{1}{r^2} - \frac{1}{2\pi h} \frac{1}{r^3} \right] = 0$$

giving

$$r_{cr} = 2 \frac{k}{h}$$

The second derivative, evaluated at  $r = r_{cr}$ , is

$$\begin{aligned} \frac{d}{dr} \left[ \frac{dR_{tot}}{dr} \right] &= \left[ -\frac{1}{2\pi k} \frac{1}{r^3} + \frac{3}{2\pi h} \frac{1}{r^4} \right]_{r=r_{cr}} \\ &= \frac{1}{(2k/h)^3} \left\{ -\frac{1}{2\pi k} + \frac{3}{2\pi h} \frac{1}{2k/h} \right\} = \frac{1}{(2k/h)^3} \frac{1}{2\pi k} \left\{ -1 + \frac{3}{2} \right\} > 0 \end{aligned}$$

Hence, it follows no optimum  $R_{tot}$  exists. We refer to this condition as the critical insulation radius. See Example 3.6 which considers this situation for a cylindrical system.

### PROBLEM 3.67

**KNOWN:** Thickness of hollow aluminum sphere and insulation layer. Heat rate and inner surface temperature. Ambient air temperature and convection coefficient.

**FIND:** Thermal conductivity of insulation.

**SCHEMATIC:**

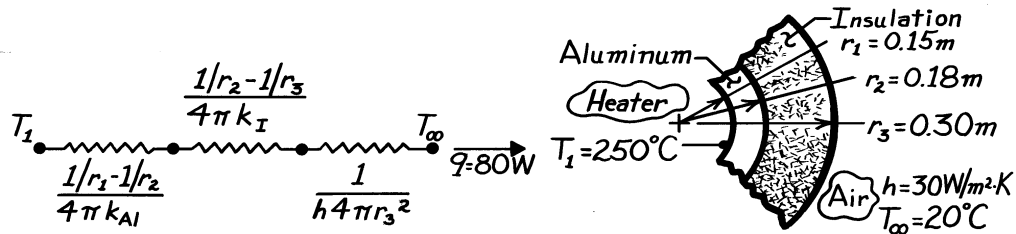

**ASSUMPTIONS:** (1) Steady-state conditions, (2) One-dimensional radial conduction, (3) Constant properties, (4) Negligible contact resistance, (5) Negligible radiation exchange at outer surface.

**PROPERTIES:** Table A-1, Aluminum (523K):  $k \approx 230$  W/m·K.

**ANALYSIS:** From the thermal circuit,

$$q = \frac{T_1 - T_\infty}{R_{\text{tot}}} = \frac{T_1 - T_\infty}{\frac{1/r_1 - 1/r_2}{4\pi k_{Al}} + \frac{1/r_2 - 1/r_3}{4\pi k_I} + \frac{1}{h4\pi r_3^2}}$$

$$q = \frac{(250 - 20)^\circ \text{C}}{\left[ \frac{1/0.15 - 1/0.18}{4\pi(230)} + \frac{1/0.18 - 1/0.30}{4\pi k_I} + \frac{1}{30(4\pi)(0.3)^2} \right] \frac{\text{K}}{\text{W}}} = 80 \text{ W}$$

or

$$3.84 \times 10^{-4} + \frac{0.177}{k_I} + 0.0029 = \frac{230}{80} = 2.875.$$

Solving for the unknown thermal conductivity, find

$$k_I = 0.062 \text{ W/m}\cdot\text{K.}$$

<

**COMMENTS:** The dominant contribution to the total thermal resistance is made by the insulation. Hence uncertainties in knowledge of  $h$  or  $k_{Al}$  have a negligible effect on the accuracy of the  $k_I$  measurement.

### PROBLEM 3.68

**KNOWN:** Dimensions of spherical, stainless steel liquid oxygen (LOX) storage container. Boiling point and latent heat of fusion of LOX. Environmental temperature.

**FIND:** Thermal isolation system which maintains boil-off below 1 kg/day.

**SCHEMATIC:**

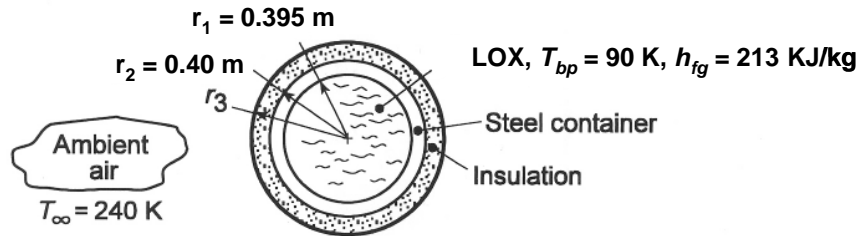

**ASSUMPTIONS:** (1) One-dimensional, steady-state conditions, (2) Negligible thermal resistances associated with internal and external convection, conduction in the container wall, and contact between wall and insulation, (3) Negligible radiation at exterior surface (due to low emissivity insulation selected), (4) Constant insulation thermal conductivity.

**PROPERTIES:** Table A.1, 304 Stainless steel ( $T = 100 \text{ K}$ ):  $k_s = 9.2 \text{ W/m}\cdot\text{K}$ ; Table A.3, Reflective, aluminum foil-glass paper insulation ( $T = 150 \text{ K}$ ):  $k_i = 0.000017 \text{ W/m}\cdot\text{K}$  (see choice of insulation below).

**ANALYSIS:** The heat gain associated with a loss of 1 kg/day is

$$\dot{q} = m h_{fg} = \frac{1 \text{ kg/day}}{86,400 \text{ s/day}} \left( 2.13 \times 10^5 \text{ J/kg} \right) = 2.47 \text{ W}$$

With an overall temperature difference of  $(T_\infty - T_{bp}) = 150 \text{ K}$ , the corresponding total thermal resistance is

$$R_{\text{tot}} = \frac{\Delta T}{\dot{q}} = \frac{150 \text{ K}}{2.47 \text{ W}} = 60.7 \text{ K/W}$$

The conduction resistance of the steel wall is

$$R_{t,\text{cond},s} = \frac{1}{4\pi k_s} \left( \frac{1}{r_1} - \frac{1}{r_2} \right) = \frac{1}{4\pi (9.2 \text{ W/m}\cdot\text{K})} \left( \frac{1}{0.395 \text{ m}} - \frac{1}{0.40 \text{ m}} \right) = 2.7 \times 10^{-4} \text{ K/W}$$

With a typical combined radiation and convection heat transfer coefficient of  $h = 10 \text{ W/m}^2\cdot\text{K}$ , the resistance between the surface and the environment can be estimated as

$$R_{\text{conv},\text{rad}} = \frac{1}{hA_s} = \frac{1}{10 \text{ W/m}^2\cdot\text{K} \times 4\pi (0.40 \text{ m})^2} = 0.05 \text{ K/W}$$

It is clear that these resistances are insufficient, and reliance must be placed on the insulation. A special insulation of very low thermal conductivity should be selected. The best choice is a highly reflective foil/glass matted insulation which was developed for cryogenic applications. It follows that

$$R_{t,\text{cond},i} = 60.7 \text{ K/W} = \frac{1}{4\pi k_i} \left( \frac{1}{r_2} - \frac{1}{r_3} \right) = \frac{1}{4\pi (0.000017 \text{ W/m}\cdot\text{K})} \left( \frac{1}{0.40 \text{ m}} - \frac{1}{r_3} \right)$$

which yields  $r_3 = 0.4021 \text{ m}$ . The minimum insulation thickness is therefore  $\delta = (r_3 - r_2) = 2.1 \text{ mm}$ .

**COMMENTS:** The heat loss could be reduced well below the maximum allowable by adding more insulation. Also, in view of weight restrictions associated with launching space vehicles, consideration should be given to fabricating the LOX container from a lighter material.

### PROBLEM 3.69

**KNOWN:** Diameter and surface temperature of a spherical cryoprobe. Temperature of surrounding tissue and effective convection coefficient at interface between frozen and normal tissue.

**FIND:** Thickness of frozen tissue layer.

**SCHEMATIC:**

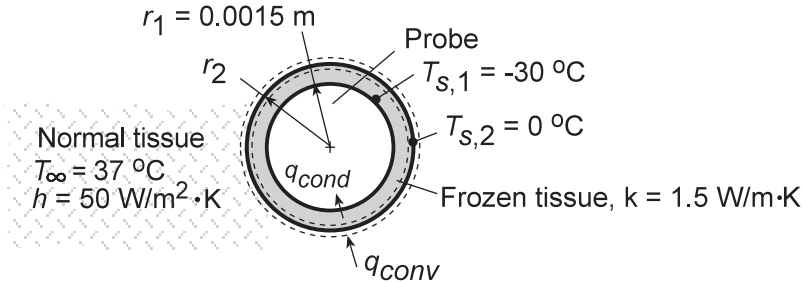

**ASSUMPTIONS:** (1) One-dimensional, steady-state conditions, (2) Negligible contact resistance between probe and frozen tissue, (3) Constant properties, (4) Negligible perfusion effects.

**ANALYSIS:** Performing an energy balance for a control surface about the phase front, it follows that

$$q_{conv} - q_{cond} = 0$$

Hence,

$$h(4\pi r_2^2)(T_\infty - T_{s,2}) = \frac{T_{s,2} - T_{s,1}}{[(1/r_1) - (1/r_2)]/4\pi k}$$

$$r_2^2 [(1/r_1) - (1/r_2)] = \frac{k(T_{s,2} - T_{s,1})}{h(T_\infty - T_{s,2})}$$

$$\left(\frac{r_2}{r_1}\right) \left[ \left(\frac{r_2}{r_1}\right) - 1 \right] = \frac{k(T_{s,2} - T_{s,1})}{hr_1(T_\infty - T_{s,2})} = \frac{1.5 \text{ W/m} \cdot \text{K}}{(50 \text{ W/m}^2 \cdot \text{K})(0.0015 \text{ m})} \left(\frac{30}{37}\right)$$

$$\left(\frac{r_2}{r_1}\right) \left[ \left(\frac{r_2}{r_1}\right) - 1 \right] = 16.2$$

$$(r_2/r_1) = 4.56$$

It follows that  $r_2 = 6.84 \text{ mm}$  and the thickness of the frozen tissue is

$$\delta = r_2 - r_1 = 5.34 \text{ mm}$$

<

### PROBLEM 3.70

**KNOWN:** Inner diameter, wall thickness and thermal conductivity of spherical vessel containing heat generating medium. Inner surface temperature without insulation. Thickness and thermal conductivity of insulation. Ambient air temperature and convection coefficient.

**FIND:** (a) Thermal energy generated within vessel, (b) Inner surface temperature of vessel with insulation.

**SCHEMATIC:**

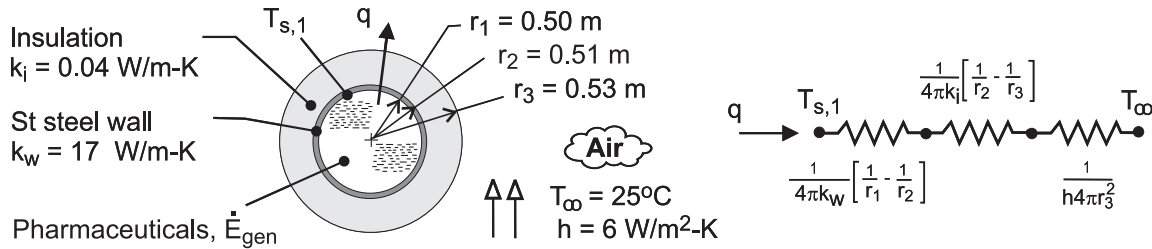

**ASSUMPTIONS:** (1) Steady-state, (2) One-dimensional, radial conduction, (3) Constant properties, (4) Negligible contact resistance, (5) Neglect radiation due to relatively low emissivity of stainless steel in part (a). In part (b), insulation resistance dominates.

**ANALYSIS:** (a) From an energy balance performed at an instant for a control surface about the pharmaceuticals,  $\dot{E}_g = q$ , in which case, without the insulation

$$\dot{E}_g = q = \frac{T_{s,1} - T_\infty}{\frac{1}{4\pi k_w} \left( \frac{1}{r_1} - \frac{1}{r_2} \right) + \frac{1}{4\pi r_3^2 h}} = \frac{(50 - 25)^\circ\text{C}}{\frac{1}{4\pi (17 \text{ W/m}\cdot\text{K})} \left( \frac{1}{0.50\text{m}} - \frac{1}{0.51\text{m}} \right) + \frac{1}{4\pi (0.51\text{m})^2 6 \text{ W/m}^2\cdot\text{K}}}$$

$$\dot{E}_g = q = \frac{25^\circ\text{C}}{\left( 1.84 \times 10^{-4} + 5.10 \times 10^{-2} \right) \text{ K/W}} = 489 \text{ W} \quad <$$

(b) With the insulation,

$$T_{s,1} = T_\infty + q \left[ \frac{1}{4\pi k_w} \left( \frac{1}{r_1} - \frac{1}{r_2} \right) + \frac{1}{4\pi k_i} \left( \frac{1}{r_2} - \frac{1}{r_3} \right) + \frac{1}{4\pi r_3^2 h} \right]$$

$$T_{s,1} = 25^\circ\text{C} + 489 \text{ W} \left[ 1.84 \times 10^{-4} + \frac{1}{4\pi (0.04)} \left( \frac{1}{0.51} - \frac{1}{0.53} \right) + \frac{1}{4\pi (0.53)^2 6} \right] \frac{\text{K}}{\text{W}}$$

$$T_{s,1} = 25^\circ\text{C} + 489 \text{ W} \left[ 1.84 \times 10^{-4} + 0.147 + 0.047 \right] \frac{\text{K}}{\text{W}} = 120^\circ\text{C} \quad <$$

**COMMENTS:** The thermal resistance associated with the vessel wall is negligible, and without the insulation the dominant resistance is due to convection. The thermal resistance of the insulation is approximately three times that due to convection. Radiation may not be negligible, and would have the effect of increasing the heat loss rate (for fixed inner surface temperature) or decreasing the inner surface temperature (for fixed heat loss rate).

### PROBLEM 3.71

**KNOWN:** Spherical tank of 1-m diameter containing an exothermic reaction and is at 200°C when the ambient air is at 25°C. Convection coefficient on outer surface is 20 W/m<sup>2</sup>·K.

**FIND:** Determine the thickness of urethane foam required to reduce the exterior temperature to 40°C. Determine the percentage reduction in the heat rate achieved using the insulation.

**SCHEMATIC:**

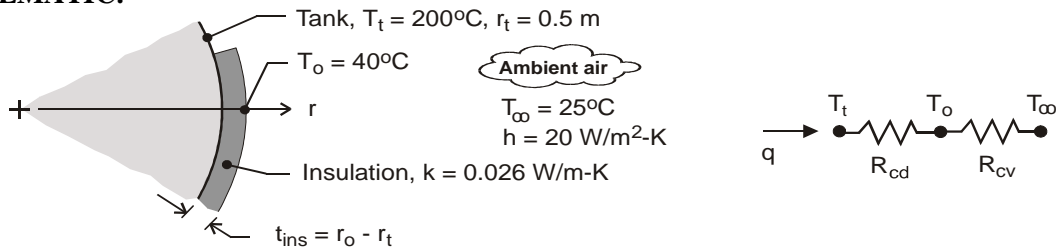

**ASSUMPTIONS:** (1) Steady-state conditions, (2) One-dimensional, radial (spherical) conduction through the insulation, (3) Convection coefficient is the same for bare and insulated exterior surface, and (4) Negligible radiation exchange between the insulation outer surface and the ambient surroundings, (5) Negligible contact resistances.

**PROPERTIES:** Table A-3, urethane, rigid foam (300 K):  $k = 0.026$  W/m·K.

**ANALYSIS:** (a) The heat transfer situation for the heat rate from the tank can be represented by the thermal circuit shown above. The heat rate from the tank is

$$q = \frac{T_t - T_\infty}{R_{cd} + R_{cv}}$$

where the thermal resistances associated with conduction within the insulation (Eq. 3.41) and convection for the exterior surface, respectively, are

$$R_{cd} = \frac{(1/r_t - 1/r_o)}{4\pi k} = \frac{(1/0.5 - 1/r_o)}{4\pi \times 0.026 \text{ W/m} \cdot \text{K}} = \frac{(1/0.5 - 1/r_o)}{0.3267} \text{ K/W}$$

$$R_{cv} = \frac{1}{hA_s} = \frac{1}{4\pi hr_o^2} = \frac{1}{4\pi \times 20 \text{ W/m}^2 \cdot \text{K} \times r_o^2} = 3.979 \times 10^{-3} r_o^{-2} \text{ K/W}$$

To determine the required insulation thickness so that  $T_o = 40^\circ\text{C}$ , perform an energy balance on the o-node.

$$\frac{T_t - T_o}{R_{cd}} + \frac{T_\infty - T_o}{R_{cv}} = 0$$

$$\frac{(200 - 40) \text{ K}}{(1/0.5 - 1/r_o)/0.3267 \text{ K/W}} + \frac{(25 - 40) \text{ K}}{3.979 \times 10^{-3} r_o^2 \text{ K/W}} = 0$$

$$r_o = 0.5135 \text{ m} \quad t = r_o - r_t = (0.5135 - 0.5000) \text{ m} = 13.5 \text{ mm} \quad <$$

From the rate equation, for the bare and insulated surfaces, respectively,

$$q_o = \frac{T_t - T_\infty}{1/4\pi hr_t^2} = \frac{(200 - 25) \text{ K}}{0.01592 \text{ K/W}} = 10.99 \text{ kW}$$

$$q_{ins} = \frac{T_t - T_\infty}{R_{cd} + R_{cv}} = \frac{(200 - 25)}{(0.161 + 0.01592) \text{ K/W}} = 0.994 \text{ kW}$$

Hence, the percentage reduction in heat loss achieved with the insulation is,

$$\frac{q_{ins} - q_o}{q_o} \times 100 = -\frac{0.994 - 10.99}{10.99} \times 100 = 91\% \quad <$$

**COMMENTS:** (1) Contact resistances will reduce the required insulation thickness. (2) Radiation may be shown to be negligible by considering the case of  $\varepsilon = 1$ .

### PROBLEM 3.72

**KNOWN:** Dimensions and materials used for composite spherical shell. Heat generation associated with stored material.

**FIND:** Inner surface temperature,  $T_1$ , of lead (proposal is flawed if this temperature exceeds the melting point).

**SCHEMATIC:**

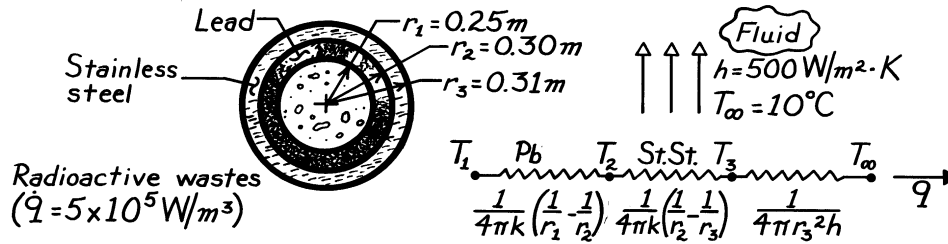

**ASSUMPTIONS:** (1) One-dimensional conduction, (2) Steady-state conditions, (3) Constant properties at 300K, (4) Negligible contact resistance.

**PROPERTIES:** Table A-1, Lead:  $k = 35.3 \text{ W/m}\cdot\text{K}$ , MP = 601K; St.St.:  $15.1 \text{ W/m}\cdot\text{K}$ .

**ANALYSIS:** From the thermal circuit, it follows that

$$q = \frac{T_1 - T_\infty}{R_{\text{tot}}} = \dot{q} \left[ \frac{4}{3} \pi r_1^3 \right]$$

Evaluate the thermal resistances,

$$R_{\text{Pb}} = \left[ 1 / (4\pi \times 35.3 \text{ W/m}\cdot\text{K}) \right] \left[ \frac{1}{0.25\text{m}} - \frac{1}{0.30\text{m}} \right] = 0.00150 \text{ K/W}$$

$$R_{\text{St.St.}} = \left[ 1 / (4\pi \times 15.1 \text{ W/m}\cdot\text{K}) \right] \left[ \frac{1}{0.30\text{m}} - \frac{1}{0.31\text{m}} \right] = 0.000567 \text{ K/W}$$

$$R_{\text{conv}} = \left[ 1 / (4\pi \times 0.31^2 \text{ m}^2 \times 500 \text{ W/m}^2 \cdot \text{K}) \right] = 0.00166 \text{ K/W}$$

$$R_{\text{tot}} = 0.00372 \text{ K/W.}$$

The heat rate is  $q = 5 \times 10^5 \text{ W/m}^3 (4\pi/3)(0.25\text{m})^3 = 32,725 \text{ W}$ . The inner surface temperature is

$$T_1 = T_\infty + R_{\text{tot}} q = 283\text{K} + 0.00372\text{K/W} (32,725 \text{ W})$$

$$T_1 = 405 \text{ K} < \text{MP} = 601\text{K.} \quad <$$

Hence, from the thermal standpoint, the proposal is adequate.

**COMMENTS:** In fabrication, attention should be given to maintaining a good thermal contact. A protective outer coating should be applied to prevent long term corrosion of the stainless steel.

### PROBLEM 3.73

**KNOWN:** Representation of the eye with a contact lens as a composite spherical system subjected to convection processes at the boundaries.

**FIND:** (a) Thermal circuits with and without contact lens in place, (b) Heat loss from anterior chamber for both cases, and (c) Implications of the heat loss calculations.

**SCHEMATIC:**

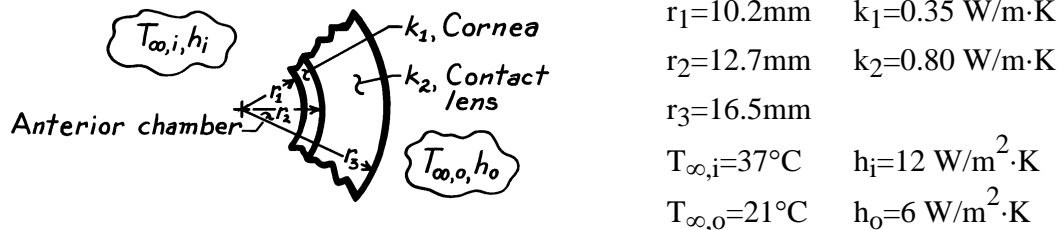

**ASSUMPTIONS:** (1) Steady-state conditions, (2) Eye is represented as 1/3 sphere, (3) Convection coefficient,  $h_o$ , unchanged with or without lens present, (4) Negligible contact resistance.

**ANALYSIS:** (a) Using Eqs. 3.9 and 3.41 to express the resistance terms, the thermal circuits are:

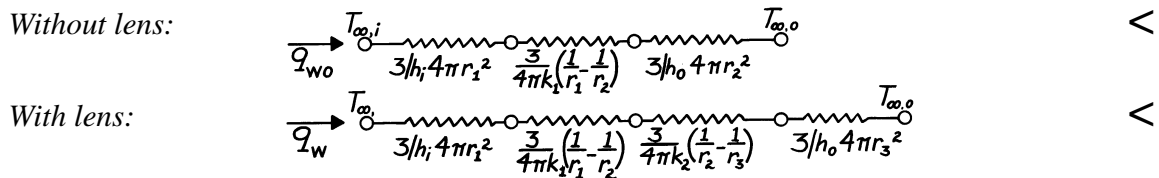

(b) The heat losses for both cases can be determined as  $q = (T_{\infty,i} - T_{\infty,o})/R_t$ , where  $R_t$  is the thermal resistance from the above circuits.

$$\text{Without lens: } R_{t,wo} = \frac{3}{12\text{ W/m}^2 \cdot \text{K} 4\pi (10.2 \times 10^{-3}\text{ m})^2} + \frac{3}{4\pi \times 0.35\text{ W/m}\cdot\text{K} \left[ \frac{1}{10.2} - \frac{1}{12.7} \right]} \frac{1}{10^{-3}\text{ m}}$$

$$+ \frac{3}{6\text{ W/m}^2 \cdot \text{K} 4\pi (12.7 \times 10^{-3}\text{ m})^2} = 191.2\text{ K/W} + 13.2\text{ K/W} + 246.7\text{ K/W} = 451.1\text{ K/W}$$

$$\text{With lens: } R_{t,w} = 191.2\text{ K/W} + 13.2\text{ K/W} + \frac{3}{4\pi \times 0.80\text{ W/m}\cdot\text{K} \left[ \frac{1}{12.7} - \frac{1}{16.5} \right]} \frac{1}{10^{-3}\text{ m}}$$

$$+ \frac{3}{6\text{ W/m}^2 \cdot \text{K} 4\pi (16.5 \times 10^{-3}\text{ m})^2} = 191.2\text{ K/W} + 13.2\text{ K/W} + 5.41\text{ K/W} + 146.2\text{ K/W} = 356.0\text{ K/W}$$

Hence the heat loss rates from the anterior chamber are

$$\text{Without lens: } q_{wo} = (37 - 21)^\circ\text{C} / 451.1\text{ K/W} = 35.5\text{ mW} \quad <$$

$$\text{With lens: } q_w = (37 - 21)^\circ\text{C} / 356.0\text{ K/W} = 44.9\text{ mW} \quad <$$

(c) The heat loss from the anterior chamber increases by approximately 20% when the contact lens is in place, implying that the outer radius,  $r_3$ , is less than the critical radius.



### PROBLEM 3.74

**KNOWN:** Thermal conductivity and inner and outer radii of a hollow sphere subjected to a uniform heat flux at its outer surface and maintained at a uniform temperature on the inner surface.

**FIND:** (a) Expression for radial temperature distribution, (b) Heat flux required to maintain prescribed surface temperatures.

**SCHEMATIC:**

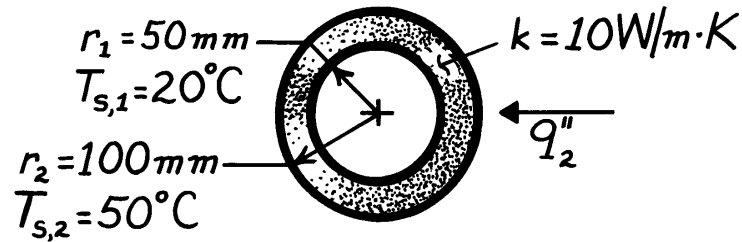

**ASSUMPTIONS:** (1) Steady-state conditions, (2) One-dimensional radial conduction, (3) No generation, (4) Constant properties.

**ANALYSIS:** (a) For the assumptions, the temperature distribution may be obtained by integrating Fourier's law, Eq. 3.38. That is,

$$\frac{q_r}{4\pi} \int_{r_1}^r \frac{dr}{r^2} = -k \int_{T_{s,1}}^T dT \quad \text{or} \quad -\frac{q_r}{4\pi} \frac{1}{r} \Big|_{r_1}^r = -k(T - T_{s,1}).$$

Hence,

$$T(r) = T_{s,1} + \frac{q_r}{4\pi k} \left[ \frac{1}{r} - \frac{1}{r_1} \right]$$

or, with  $q_2'' \equiv q_r / 4\pi r_2^2$ ,

$$T(r) = T_{s,1} + \frac{q_2'' r_2^2}{k} \left[ \frac{1}{r} - \frac{1}{r_1} \right] \quad <$$

(b) Applying the above result at  $r_2$ ,

$$q_2'' = \frac{k(T_{s,2} - T_{s,1})}{r_2^2 \left[ \frac{1}{r_2} - \frac{1}{r_1} \right]} = \frac{10 \text{ W/m} \cdot \text{K} (50 - 20)^\circ \text{C}}{(0.1 \text{ m})^2 \left[ \frac{1}{0.1} - \frac{1}{0.05} \right] \frac{1}{\text{m}}} = -3000 \text{ W/m}^2. \quad <$$

**COMMENTS:** (1) The desired temperature distribution could also be obtained by solving the appropriate form of the heat equation,

$$\frac{d}{dr} \left[ r^2 \frac{dT}{dr} \right] = 0$$

and applying the boundary conditions  $T(r_1) = T_{s,1}$  and  $-k \frac{dT}{dr} \Big|_{r_2} = q_2''$ .

(2) The negative sign on  $q_2''$  implies heat transfer in the negative  $r$  direction.

### PROBLEM 3.75

**KNOWN:** Volumetric heat generation occurring within the cavity of a spherical shell of prescribed dimensions. Convection conditions at outer surface.

**FIND:** Expression for steady-state temperature distribution in shell.

**SCHEMATIC:**

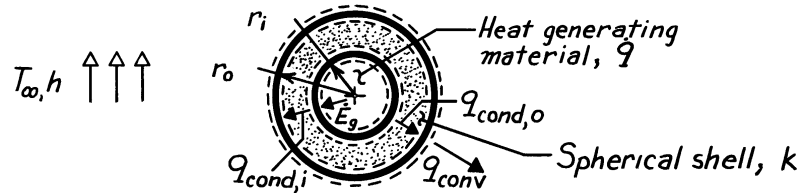

**ASSUMPTIONS:** (1) One-dimensional radial conduction, (2) Steady-state conditions, (3) Constant properties, (4) Uniform generation within the shell cavity, (5) Negligible radiation.

**ANALYSIS:** For the prescribed conditions, the appropriate form of the heat equation is

$$\frac{d}{dr} \left[ r^2 \frac{dT}{dr} \right] = 0$$

Integrate twice to obtain,

$$r^2 \frac{dT}{dr} = C_1 \quad \text{and} \quad T = -\frac{C_1}{r} + C_2. \quad (1,2)$$

The boundary conditions may be obtained from energy balances at the inner and outer surfaces. At the inner surface ( $r_i$ ),

$$\dot{E}_g = \dot{q} \left( 4/3 \pi r_i^3 \right) = q_{\text{cond},i} = -k \left( 4 \pi r_i^2 \right) \left. \frac{dT}{dr} \right|_{r_i} \quad \left. \frac{dT}{dr} \right|_{r_i} = -\dot{q} r_i / 3k. \quad (3)$$

At the outer surface ( $r_o$ ),

$$q_{\text{cond},o} = -k 4 \pi r_o^2 \left. \frac{dT}{dr} \right|_{r_o} = q_{\text{conv}} = h 4 \pi r_o^2 \left[ T(r_o) - T_{\infty} \right] \\ \left. \frac{dT}{dr} \right|_{r_o} = -(h/k) \left[ T(r_o) - T_{\infty} \right]. \quad (4)$$

From Eqs. (1) and (3),  $C_1 = -\dot{q} r_i^3 / 3k$ . From Eqs. (1), (2) and (4)

$$-\frac{\dot{q} r_i^3}{3k r_o^2} = -\left[ \frac{h}{k} \right] \left[ \frac{\dot{q} r_i^3}{3r_o k} + C_2 - T_{\infty} \right] \\ C_2 = \frac{\dot{q} r_i^3}{3h r_o^2} - \frac{\dot{q} r_i^3}{3r_o k} + T_{\infty}.$$

Hence, the temperature distribution is

$$T = \frac{\dot{q} r_i^3}{3k} \left[ \frac{1}{r} - \frac{1}{r_o} \right] + \frac{\dot{q} r_i^3}{3h r_o^2} + T_{\infty}. \quad <$$

**COMMENTS:** Note that  $\dot{E}_g = q_{\text{cond},i} = q_{\text{cond},o} = q_{\text{conv}}$ .

### PROBLEM 3.76

**KNOWN:** Spherical tank of 3-m diameter containing LP gas at  $-60^{\circ}\text{C}$  with 250 mm thickness of insulation having thermal conductivity of  $0.06\text{ W/m}\cdot\text{K}$ . Ambient air temperature and convection coefficient on the outer surface are  $20^{\circ}\text{C}$  and  $6\text{ W/m}^2\cdot\text{K}$ , respectively.

**FIND:** (a) Determine the radial position in the insulation at which the temperature is  $0^{\circ}\text{C}$  and (b) If the insulation is pervious to moisture, what conclusions can be reached about ice formation? What effect will ice formation have on the heat gain? How can this situation be avoided?

**SCHEMATIC:**

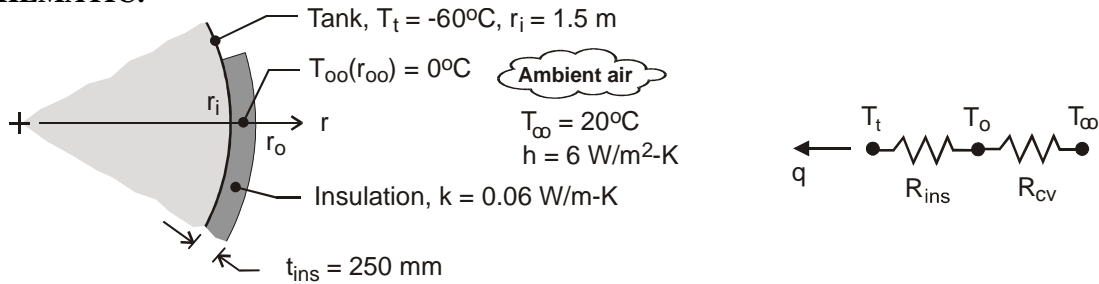

**ASSUMPTIONS:** (1) Steady-state conditions, (2) One-dimensional, radial (spherical) conduction through the insulation, and (3) Negligible radiation exchange between the insulation outer surface and the ambient surroundings, (4) Inner surface of insulation at  $T_t$ .

**ANALYSIS:** (a) The heat transfer situation can be represented by the thermal circuit shown above. The heat gain to the tank is

$$q = \frac{T_{\infty} - T_t}{R_{\text{ins}} + R_{\text{cv}}} = \frac{[20 - (-60)]\text{K}}{(0.1263 + 4.33 \times 10^{-3})\text{K/W}} = 612.4\text{ W}$$

where the thermal resistances for the insulation (see Table 3.3) and the convection process on the outer surface are, respectively,

$$R_{\text{ins}} = \frac{1/r_i - 1/r_o}{4\pi k} = \frac{(1/1.50 - 1/1.75)\text{m}^{-1}}{4\pi \times 0.06\text{ W/m}\cdot\text{K}} = 0.1263\text{ K/W}$$

$$R_{\text{cv}} = \frac{1}{hA_s} = \frac{1}{h4\pi r_o^2} = \frac{1}{6\text{ W/m}^2\cdot\text{K} \times 4\pi (1.75\text{ m})^2} = 4.33 \times 10^{-3}\text{ K/W}$$

To determine the location within the insulation where  $T_{\text{oo}}(r_{\text{oo}}) = 0^{\circ}\text{C}$ , use the conduction rate equation, Eq. 3.41,

$$q = \frac{4\pi k(T_{\text{oo}} - T_t)}{(1/r_i - 1/r_{\text{oo}})} \quad r_{\text{oo}} = \left[ \frac{1}{r_i} - \frac{4\pi k(T_{\text{oo}} - T_t)}{q} \right]^{-1}$$

and substituting numerical values, find

$$r_{\text{oo}} = \left[ \frac{1}{1.5\text{ m}} - \frac{4\pi \times 0.06\text{ W/m}\cdot\text{K}(0 - (-60))\text{K}}{612.4\text{ W}} \right]^{-1} = 1.687\text{ m} <$$

(b) With  $r_{\text{oo}} = 1.687\text{ m}$ , we'd expect the region of the insulation  $r_i \leq r \leq r_{\text{oo}}$  to be filled with ice formations if the insulation is pervious to water vapor. The effect of the ice formation is to substantially increase the heat gain since  $k_{\text{ice}}$  is nearly twice that of  $k_{\text{ins}}$ , and the ice region is of thickness  $(1.687 - 1.50)\text{m} = 187\text{ mm}$ . To avoid ice formation, a vapor barrier should be installed at a radius larger than  $r_{\text{oo}}$ .

### PROBLEM 3.77

**KNOWN:** Radius and heat dissipation of a hemispherical source embedded in a substrate of prescribed thermal conductivity. Source and substrate boundary conditions.

**FIND:** Substrate temperature distribution and surface temperature of heat source.

**SCHEMATIC:**

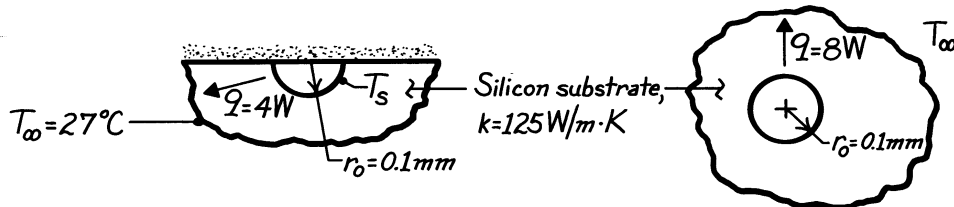

**ASSUMPTIONS:** (1) Top surface is adiabatic. Hence, hemispherical source in semi-infinite medium is equivalent to spherical source in infinite medium (with  $q = 8 \text{ W}$ ) and heat transfer is one-dimensional in the radial direction, (2) Steady-state conditions, (3) Constant properties, (4) No generation.

**ANALYSIS:** Heat equation reduces to

$$\frac{1}{r^2} \frac{d}{dr} \left( r^2 \frac{dT}{dr} \right) = 0 \quad r^2 dT/dr = C_1$$

$$T(r) = -C_1/r + C_2.$$

Boundary conditions:

$$T(\infty) = T_\infty \quad T(r_0) = T_s$$

Hence,  $C_2 = T_\infty$  and

$$T_s = -C_1/r_0 + T_\infty \quad \text{and} \quad C_1 = r_0(T_\infty - T_s).$$

The temperature distribution has the form

$$T(r) = T_\infty + (T_s - T_\infty)r_0/r \quad <$$

and the heat rate is

$$q = -kA dT/dr = -k2\pi r^2 \left[ -(T_s - T_\infty)r_0/r^2 \right] = k2\pi r_0(T_s - T_\infty)$$

It follows that

$$T_s - T_\infty = \frac{q}{k2\pi r_0} = \frac{4 \text{ W}}{125 \text{ W/m} \cdot \text{K} \cdot 2\pi (10^{-4} \text{ m})} = 50.9^\circ \text{C}$$

$$T_s = 77.9^\circ \text{C}. \quad <$$

**COMMENTS:** For the semi-infinite (or infinite) medium approximation to be valid, the substrate dimensions must be much larger than those of the transistor.

### PROBLEM 3.78

**KNOWN:** Critical and normal tissue temperatures. Radius of spherical heat source and radius of tissue to be maintained above the critical temperature. Tissue thermal conductivity.

**FIND:** General expression for radial temperature distribution in tissue. Heat rate required to maintain prescribed thermal conditions.

**SCHEMATIC:**

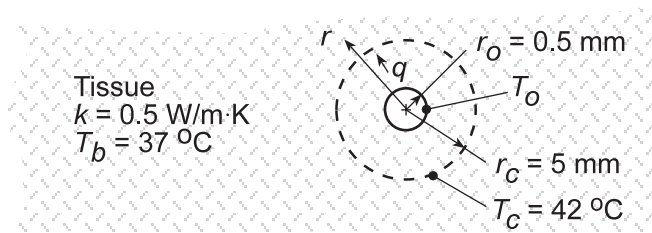

**ASSUMPTIONS:** (1) One-dimensional, steady-state conduction, (2) Constant  $k$ , (3) Negligible contact resistance.

**ANALYSIS:** The appropriate form of the heat equation is

$$\frac{1}{r^2} \frac{d}{dr} \left( r \frac{dT}{dr} \right) = 0$$

Integrating twice,

$$\frac{dT}{dr} = \frac{C_1}{r^2}$$

$$T(r) = -\frac{C_1}{r} + C_2$$

Since  $T \rightarrow T_b$  as  $r \rightarrow \infty$ ,  $C_2 = T_b$ . At  $r = r_o$ ,  $q = -k \left( 4\pi r_o^2 \right) \left. \frac{dT}{dr} \right|_{r_o} = -4\pi k r_o^2 C_1 / r_o^2 = -4\pi k C_1$ .

Hence,  $C_1 = -q/4\pi k$  and the temperature distribution is

$$T(r) = \frac{q}{4\pi k r} + T_b \quad <$$

It follows that

$$q = 4\pi k r \left[ T(r) - T_b \right]$$

Applying this result at  $r = r_c$ ,

$$q = 4\pi (0.5 \text{ W/m}\cdot\text{K})(0.005 \text{ m})(42 - 37)^\circ \text{C} = 0.157 \text{ W} \quad <$$

**COMMENTS:** At  $r_o = 0.0005 \text{ m}$ ,  $T(r_o) = \left[ q / (4\pi k r_o) \right] + T_b = 87^\circ\text{C}$ . Proximity of this temperature to the boiling point of water suggests the need to operate at a lower power dissipation level.

### PROBLEM 3.79

**KNOWN:** Wall of thermal conductivity  $k$  and thickness  $L$  with uniform generation  $\dot{q}$ ; strip heater with uniform heat flux  $q_o''$ ; prescribed inside and outside air conditions ( $h_i, T_{\infty,i}, h_o, T_{\infty,o}$ ).

**FIND:** (a) Sketch temperature distribution in wall if none of the heat generated within the wall is lost to the outside air, (b) Temperatures at the wall boundaries  $T(0)$  and  $T(L)$  for the prescribed condition, (c) Value of  $q_o''$  required to maintain this condition, (d) Temperature of the outer surface,  $T(L)$ , if  $\dot{q}=0$  but  $q_o''$  corresponds to the value calculated in (c).

**SCHEMATIC:**

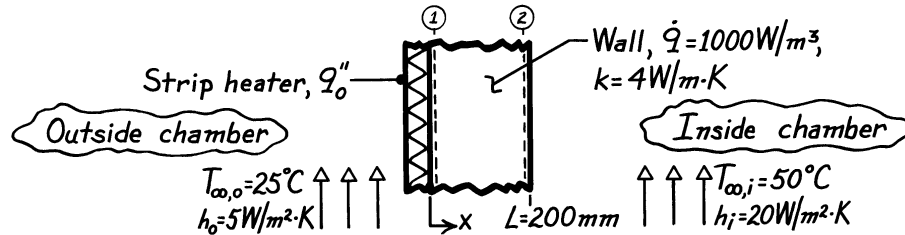

**ASSUMPTIONS:** (1) Steady-state conditions, (2) One-dimensional conduction, (3) Uniform volumetric generation, (4) Constant properties.

**ANALYSIS:** (a) If none of the heat generated within the wall is lost to the *outside* of the chamber, the gradient at  $x = 0$  must be zero. Since  $\dot{q}$  is uniform, the temperature distribution is parabolic, with

$T(L) > T_{\infty,i}$ .

(b) To find temperatures at the boundaries of wall, begin with the general solution to the appropriate form of the heat equation (Eq.3.40).

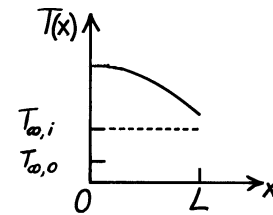

$$T(x) = -\frac{\dot{q}}{2k}x^2 + C_1x + C_2 \quad (1)$$

From the first boundary condition,

$$\left. \frac{dT}{dx} \right|_{x=0} = 0 \quad \rightarrow \quad C_1 = 0. \quad (2)$$

Two approaches are possible using different forms for the second boundary condition.

*Approach No. 1:* With boundary condition  $\rightarrow T(0) = T_1$

$$T(x) = -\frac{\dot{q}}{2k}x^2 + T_1 \quad (3)$$

To find  $T_1$ , perform an overall energy balance on the wall

$$\dot{E}_{in} - \dot{E}_{out} + \dot{E}_g = 0$$

$$-h[T(L) - T_{\infty,i}] + \dot{q}L = 0 \quad T(L) = T_2 = T_{\infty,i} + \frac{\dot{q}L}{h} \quad (4)$$

Continued ...

**PROBLEM 3.79 (Cont.)**

and from Eq. (3) with  $x = L$  and  $T(L) = T_2$ ,

$$T(L) = -\frac{\dot{q}}{2k}L^2 + T_1 \quad \text{or} \quad T_1 = T_2 + \frac{\dot{q}}{2k}L^2 = T_{\infty,i} + \frac{\dot{q}L}{h} + \frac{\dot{q}L^2}{2k} \quad (5,6)$$

Substituting numerical values into Eqs. (4) and (6), find

$$T_2 = 50^\circ\text{C} + 1000 \text{ W/m}^3 \times 0.200 \text{ m} / 20 \text{ W/m}^2 \cdot \text{K} = 50^\circ\text{C} + 10^\circ\text{C} = 60^\circ\text{C} \quad <$$

$$T_1 = 60^\circ\text{C} + 1000 \text{ W/m}^3 \times (0.200 \text{ m})^2 / 2 \times 4 \text{ W/m} \cdot \text{K} = 65^\circ\text{C}. \quad <$$

*Approach No. 2:* Using the boundary condition

$$-k \left. \frac{dT}{dx} \right|_{x=L} = h [T(L) - T_{\infty,i}]$$

yields the following temperature distribution which can be evaluated at  $x = 0, L$  for the required temperatures,

$$T(x) = -\frac{\dot{q}}{2k}(x^2 - L^2) + \frac{\dot{q}L}{h} + T_{\infty,i}.$$

(c) The value of  $q''_o$  when  $T(0) = T_1 = 65^\circ\text{C}$  follows from the circuit

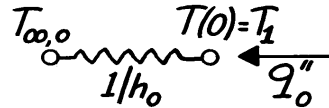

$$q''_o = \frac{T_1 - T_{\infty,o}}{1/h_o}$$

$$q''_o = 5 \text{ W/m}^2 \cdot \text{K} (65 - 25)^\circ\text{C} = 200 \text{ W/m}^2. \quad <$$

(d) With  $\dot{q}=0$ , the situation is represented by the thermal circuit shown. Hence,

$$q''_o = q''_a + q''_b$$

$$q''_o = \frac{T_1 - T_{\infty,o}}{1/h_o} + \frac{T_1 - T_{\infty,i}}{L/k + 1/h_i}$$

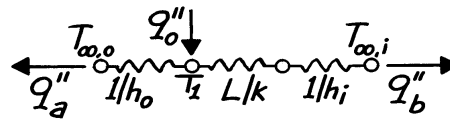

which yields

$$T_1 = 55^\circ\text{C}. \quad <$$

### PROBLEM 3.80

**KNOWN:** Cylindrical and spherical shells with uniform heat generation and surface temperatures.

**FIND:** Radial distributions of temperature, heat flux and heat rate.

**SCHEMATIC:**

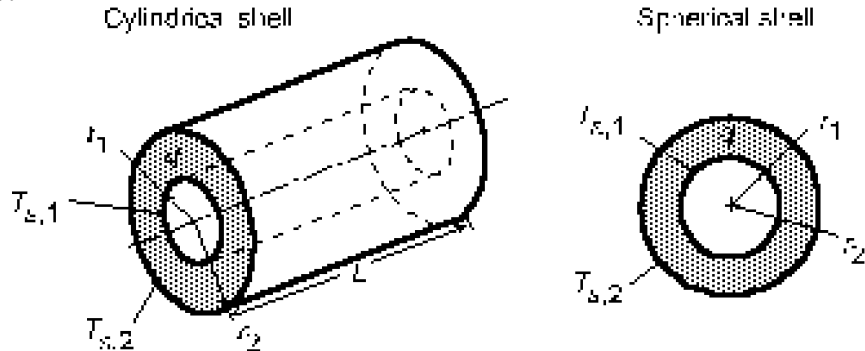

**ASSUMPTIONS:** (1) One-dimensional, steady-state conduction, (2) Uniform heat generation, (3) Constant  $k$ .

**ANALYSIS:** (a) For the *cylindrical shell*, the appropriate form of the heat equation is

$$\frac{1}{r} \frac{d}{dr} \left( r \frac{dT}{dr} \right) + \frac{\dot{q}}{k} = 0$$

The general solution is

$$T(r) = -\frac{\dot{q}}{4k} r^2 + C_1 \ln r + C_2$$

Applying the boundary conditions, it follows that

$$T(r_1) = T_{s,1} = -\frac{\dot{q}}{4k} r_1^2 + C_1 \ln r_1 + C_2$$

$$T(r_2) = T_{s,2} = -\frac{\dot{q}}{4k} r_2^2 + C_1 \ln r_2 + C_2$$

which may be solved for

$$C_1 = \left[ (\dot{q}/4k)(r_2^2 - r_1^2) + (T_{s,2} - T_{s,1}) \right] / \ln(r_2/r_1)$$

$$C_2 = T_{s,2} + (\dot{q}/4k)r_2^2 - C_1 \ln r_2$$

Hence,

$$T(r) = T_{s,2} + (\dot{q}/4k)(r_2^2 - r^2) + \left[ (\dot{q}/4k)(r_2^2 - r_1^2) + (T_{s,2} - T_{s,1}) \right] \frac{\ln(r/r_2)}{\ln(r_2/r_1)} \quad <$$

With  $q'' = -k dT/dr$ , the heat flux distribution is

$$q''(r) = \frac{\dot{q}}{2} r - \frac{k \left[ (\dot{q}/4k)(r_2^2 - r_1^2) + (T_{s,2} - T_{s,1}) \right]}{r \ln(r_2/r_1)} \quad <$$

Continued...



**PROBLEM 3.80 (Cont.)**

Similarly, with  $q = q'' A(r) = q'' (2\pi rL)$ , the heat rate distribution is

$$q(r) = \pi L \dot{q} r^2 - \frac{2\pi L k \left[ (\dot{q}/4k)(r_2^2 - r_1^2) + (T_{s,2} - T_{s,1}) \right]}{\ln(r_2/r_1)} \quad <$$

(b) For the *spherical shell*, the heat equation and general solution are

$$\frac{1}{r^2} \frac{d}{dr} \left( r^2 \frac{dT}{dr} \right) + \frac{\dot{q}}{k} = 0$$

$$T(r) = -(\dot{q}/6k)r^2 - C_1/r + C_2$$

Applying the boundary conditions, it follows that

$$T(r_1) = T_{s,1} = -(\dot{q}/6k)r_1^2 - C_1/r_1 + C_2$$

$$T(r_2) = T_{s,2} = -(\dot{q}/6k)r_2^2 - C_1/r_2 + C_2$$

Hence,

$$C_1 = \left[ (\dot{q}/6k)(r_2^2 - r_1^2) + (T_{s,2} - T_{s,1}) \right] / \left[ (1/r_1) - (1/r_2) \right]$$

$$C_2 = T_{s,2} + (\dot{q}/6k)r_2^2 + C_1/r_2$$

and

$$T(r) = T_{s,2} + (\dot{q}/6k)(r_2^2 - r^2) - \left[ (\dot{q}/6k)(r_2^2 - r_1^2) + (T_{s,2} - T_{s,1}) \right] \frac{(1/r) - (1/r_2)}{(1/r_1) - (1/r_2)} \quad <$$

With  $q''(r) = -k dT/dr$ , the heat flux distribution is

$$q''(r) = \frac{\dot{q}}{3} r - \frac{\left[ (\dot{q}/6)(r_2^2 - r_1^2) + k(T_{s,2} - T_{s,1}) \right]}{(1/r_1) - (1/r_2)} \frac{1}{r^2} \quad <$$

and, with  $q = q''(4\pi r^2)$ , the heat rate distribution is

$$q(r) = \frac{4\pi \dot{q}}{3} r^3 - \frac{4\pi \left[ (\dot{q}/6)(r_2^2 - r_1^2) + k(T_{s,2} - T_{s,1}) \right]}{(1/r_1) - (1/r_2)} \quad <$$

### PROBLEM 3.81

**KNOWN:** Plane wall with internal heat generation which is insulated at the inner surface and subjected to a convection process at the outer surface.

**FIND:** Maximum temperature in the wall.

**SCHEMATIC:**

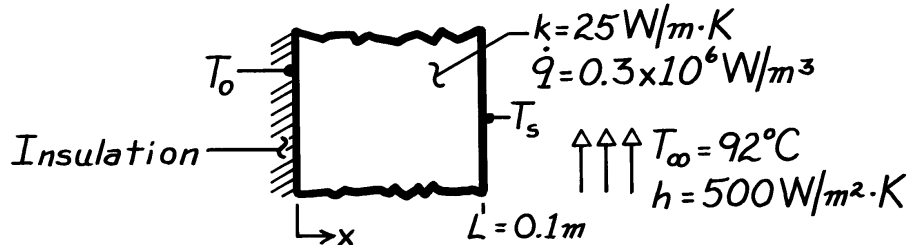

**ASSUMPTIONS:** (1) Steady-state conditions, (2) One-dimensional conduction with uniform volumetric heat generation, (3) Inner surface is adiabatic.

**ANALYSIS:** The temperature at the inner surface is given by Eq. 3.48 and is the maximum temperature within the wall,

$$T_0 = \dot{q}L^2 / 2k + T_s.$$

The outer surface temperature follows from Eq. 3.51,

$$T_s = T_\infty + \dot{q}L/h$$

$$T_s = 92^\circ\text{C} + 0.3 \times 10^6 \frac{\text{W}}{\text{m}^3} \times 0.1\text{m} / 500\text{W/m}^2 \cdot \text{K} = 92^\circ\text{C} + 60^\circ\text{C} = 152^\circ\text{C}.$$

It follows that

$$T_0 = 0.3 \times 10^6 \text{W/m}^3 \times (0.1\text{m})^2 / 2 \times 25\text{W/m} \cdot \text{K} + 152^\circ\text{C}$$

$$T_0 = 60^\circ\text{C} + 152^\circ\text{C} = 212^\circ\text{C}. \quad <$$

**COMMENTS:** The heat flux leaving the wall can be determined from knowledge of  $h$ ,  $T_s$  and  $T_\infty$  using Newton's law of cooling.

$$q''_{\text{conv}} = h(T_s - T_\infty) = 500\text{W/m}^2 \cdot \text{K} (152 - 92)^\circ\text{C} = 30\text{kW/m}^2.$$

This same result can be determined from an energy balance on the entire wall, which has the form

$$\dot{E}_g - \dot{E}_{\text{out}} = 0$$

where

$$\dot{E}_g = \dot{q}AL \quad \text{and} \quad \dot{E}_{\text{out}} = q''_{\text{conv}} \cdot A.$$

Hence,

$$q''_{\text{conv}} = \dot{q}L = 0.3 \times 10^6 \text{W/m}^3 \times 0.1\text{m} = 30\text{kW/m}^2.$$

### PROBLEM 3.82

**KNOWN:** Diameter, thermal conductivity and microbial energy generation rate in cylindrical hay bales. Ambient conditions.

**FIND:** The maximum hay temperature for  $\dot{q} = 1, 10, \text{ and } 100 \text{ W/m}^3$ .

**SCHEMATIC:**

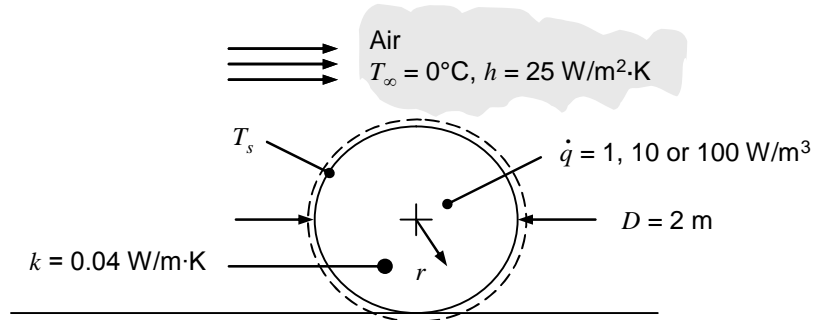

**ASSUMPTIONS:** (1) Steady-state conditions, (2) Constant properties, (3) One-dimensional heat transfer (4) Uniform volumetric generation, (5) Negligible radiation, (6) Negligible conduction to or from the ground.

**PROPERTIES:**  $k = 0.04 \text{ W/m}\cdot\text{K}$  (given).

**ANALYSIS:** The surface temperature of the dry hay is (Eq. 3.60)

$$T_s = T_\infty + \frac{\dot{q}r_o}{2h} = 0^\circ\text{C} + \frac{1\text{W/m}^3 \times 1\text{m}}{2 \times 25\text{W/m}^2 \cdot \text{K}} = 0.02^\circ\text{C} \quad <$$

whereas  $T_s = 0.2^\circ\text{C}$  and  $2.0^\circ\text{C}$  for the moist and wet hay, respectively. <

The maximum hay temperature occurs at the centerline,  $r = 0$ . From Eq. 3.58, for the dry hay,

$$T_{\max} = \frac{\dot{q}r_o^2}{4k} + T_s = \frac{1\text{W/m}^3 \times (1\text{m})^2}{4 \times 0.04 \text{ W/m}\cdot\text{K}} + 0.02^\circ\text{C} = 6.27^\circ\text{C} \quad <$$

whereas  $T_{\max} = 62.7^\circ\text{C}$  and  $627^\circ\text{C}$  for the moist and wet hay, respectively. <

**COMMENTS:** (1) The hay begins to lose its nutritional value at temperatures exceeding  $50^\circ\text{C}$ . Therefore the center of the moist hay bale will lose some of its nutritional value. (2) The center of the wet hay bale can experience very high temperatures without combusting due to lack of oxygen internal to the hay bale. However, when the farmer breaks the bale apart for feeding, oxygen is suddenly supplied to the hot hay and combustion may occur. (3) The outer surface of the hay bale differs by only  $2^\circ\text{C}$  from the dry to the wet condition, while the centerline temperature differs by over 600 degrees. The farmer cannot anticipate the potential for starting a fire by touching the outer surface of the hay bale. (4) See Opuku, Tabil, Crerar and Shaw, "Thermal Conductivity and Thermal Diffusivity of Timothy Hay," *Canadian Biosystems Engineering*, Vol. 48, pp. 3.1 - 3.6, 2006 for hay property information.

### PROBLEM 3.83

**KNOWN:** Diameter, thermal conductivity and microbial energy generation rate in cylindrical hay bales. Thin-walled tube diameter and insertion location. Temperature of flowing water and convective heat transfer coefficient inside the tube. Ambient conditions.

**FIND:** (a) Steady-state heat transfer to the water per unit length of tube, (b) Plot of the radial temperature distribution,  $T(r)$ , in the hay (c) Plot of the heat transfer to the water per unit length of tube for bale diameters of  $0.2 \text{ m} \leq D \leq 2 \text{ m}$  for  $\dot{q} = 100 \text{ W/m}^3$ .

**SCHEMATIC:**

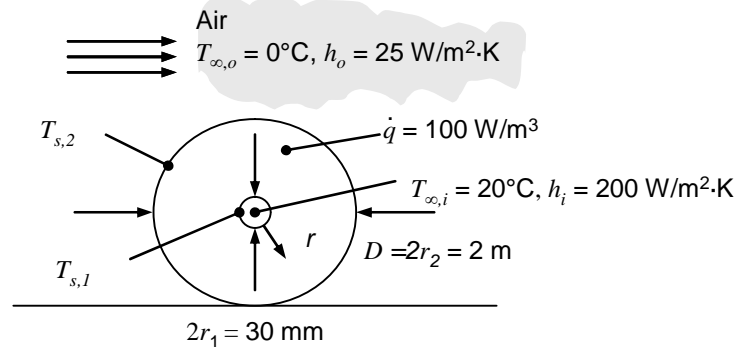

**ASSUMPTIONS:** (1) Steady-state conditions, (2) Constant properties, (3) One-dimensional heat transfer (4) Uniform volumetric generation, (5) Negligible radiation, (6) Negligible conduction to or from the ground.

**PROPERTIES:**  $k = 0.04 \text{ W/m} \cdot \text{K}$  (given).

**ANALYSIS:** (a) The temperature distribution is found by utilizing the general solution given by Eq. 3.56 with mixed boundary conditions applied at  $r_1$  and  $r_2$ . Specifically,

$$\text{at } r_1: \quad -k \left. \frac{dT}{dr} \right|_{r=r_1} = h_i [T_{\infty,i} - T_{s,1}] \quad \text{at } r_2: \quad -k \left. \frac{dT}{dr} \right|_{r=r_2} = h_o [T_{s,2} - T_{\infty,o}]$$

The solutions are given by Eqs. C.16, C.17, and C.2.

From Eq. C.16,

$$\begin{aligned} h_{\infty,i}(T_{\infty,i} - T_{s,1}) &= 200 \text{ W/m}^2 \cdot \text{K} \times (20^\circ\text{C} - T_{s,1}) \\ &= \frac{\dot{q}r_1}{2} - \frac{k \left[ \frac{\dot{q}r_2^2}{4k} \left( 1 - \frac{r_1^2}{r_2^2} \right) + (T_{s,2} - T_{s,1}) \right]}{r_1 \ln(r_2/r_1)} \\ &= \frac{100 \text{ W/m}^3 \times 15 \times 10^{-3} \text{ m}}{2} - \frac{0.04 \text{ W/m} \cdot \text{K} \left[ \frac{100 \text{ W/m}^3 (1 \text{ m})^2}{4 \times 0.04 \text{ W/m} \cdot \text{K}} \left( 1 - \frac{(15 \times 10^{-3} \text{ m})^2}{(1 \text{ m})^2} \right) + (T_{s,2} - T_{s,1}) \right]}{15 \times 10^{-3} \text{ m} \times \ln(1000/15)} \quad (1) \end{aligned}$$

Continued...

**PROBLEM 3.83 (Cont.)**

From Eq. C.17,

$$\begin{aligned}
 h_{\infty,o}(T_{s,2} - T_{\infty,o}) &= 25 \text{ W/m}^2 \cdot \text{K} \times (T_{s,2} - 0^\circ\text{C}) \\
 &= \frac{\dot{q}r_2}{2} - \frac{k \left[ \frac{\dot{q}r_2^2}{4k} \left( 1 - \frac{r_1^2}{r_2^2} \right) + (T_{s,2} - T_{s,1}) \right]}{r_2 \ln(r_2/r_1)} \\
 &= \frac{100 \text{ W/m}^3 \times 1 \text{ m}}{2} - \frac{0.04 \text{ W/m} \cdot \text{K} \left[ \frac{100 \text{ W/m}^3 (1 \text{ m})^2}{4 \times 0.04 \text{ W/m} \cdot \text{K}} \left( 1 - \frac{(15 \times 10^{-3} \text{ m})^2}{(1 \text{ m})^2} \right) + (T_{s,2} - T_{s,1}) \right]}{1 \text{ m} \times \ln(1000/15)} \quad (2)
 \end{aligned}$$

Equations (1) and (2) may be solved simultaneously to yield  $T_{s,1} = 21.54^\circ\text{C}$ ,  $T_{s,2} = 1.75^\circ\text{C}$ . The heat transfer to the cold fluid per unit length is

$$q' = h_i(2\pi r_i)(T_{s,i} - T_{\infty,i}) = 200 \text{ W/m}^2 \cdot \text{K} \times 2 \times \pi \times 15 \times 10^{-3} \text{ m} \times (21.54 - 20)^\circ\text{C} = 38.7 \text{ W/m} <$$

(b) The radial temperature distribution is evaluated from Eq. C.2 and is shown below.

$$\begin{aligned}
 T(r) &= T_{s,2} + \frac{\dot{q}r_2^2}{4k} \left( 1 - \frac{r^2}{r_2^2} \right) - \left[ \frac{\dot{q}r_2^2}{4k} \left( 1 - \frac{r_1^2}{r_2^2} \right) + (T_{s,2} - T_{s,1}) \right] \frac{\ln(r_2/r)}{\ln(r_2/r_1)} \\
 &= 1.75^\circ\text{C} + \frac{100 \text{ W/m}^3 \times (1 \text{ m})^2}{4 \times 0.04 \text{ W/m} \cdot \text{K}} \left( 1 - \frac{r^2}{(1 \text{ m})^2} \right) - \left[ \frac{100 \text{ W/m}^3 \times (1 \text{ m})^2}{4 \times 0.04 \text{ W/m} \cdot \text{K}} \left( 1 - \frac{(15 \times 10^{-3} \text{ m})^2}{(1 \text{ m})^2} \right) + (1.75^\circ\text{C} - 21.54^\circ\text{C}) \right] \\
 &\quad \times \frac{\ln(1 \text{ m}/r)}{\ln(1 \text{ m}/15 \times 10^{-3} \text{ m})}
 \end{aligned}$$

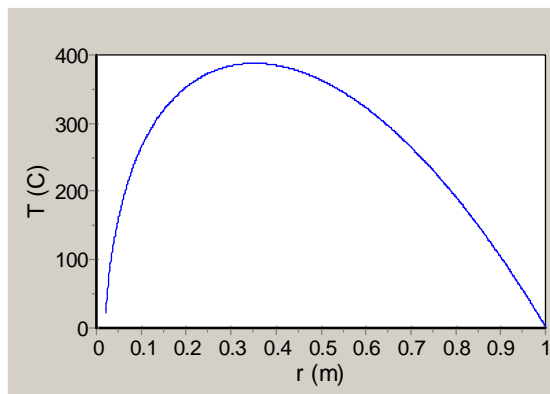

Continued...

### PROBLEM 3.83 (Cont.)

Note that the maximum temperature occurs at  $r \approx 0.35$  m.

(c) The rate of heat transfer to the cool fluid, per unit length, is shown versus the bale diameter in the plot below.

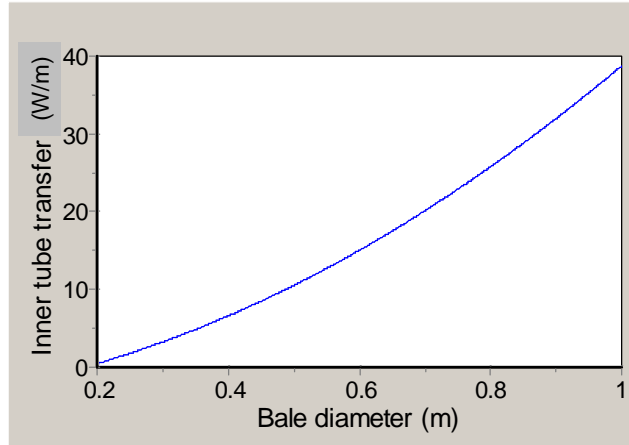

Note that at very small bale diameters, the heat transfer to the inner tube will become negative. That is, the energy generation in the bale is not sufficient to offset conduction losses from the relatively warm tube liquid to the relatively cold outside air.

**COMMENTS:** (1) The energy generated in the bale per unit length is

$\dot{E}_g' = \dot{q} \times \pi \times (r_2^2 - r_1^2) = 100 \text{ W/m}^3 \times \pi \times (1 \text{ m}^2 - (0.015 \text{ m})^2) = 314 \text{ W/m}$ . Hence, the heat transfer to the inner tube represents  $(38.7/314) \times 100 = 12.3\%$  of the total generated. The remaining 87.6% is lost to the ambient air. (2) The performance could be improved by inserting more tubes, or by stacking the bales in adjacent rows so that heat losses from the exterior surface would be minimized. (3) Evaluation of the two constants appearing in the analytical solution (Eq. 3.56) using the two mixed boundary conditions is very tedious, resulting in a cumbersome expression. Utilization of the results of Appendix C saves considerable time.

### PROBLEM 3.84

**KNOWN:** Composite wall with outer surfaces exposed to convection process.

**FIND:** (a) Volumetric heat generation and thermal conductivity for material B required for special conditions, (b) Plot of temperature distribution, (c)  $T_1$  and  $T_2$ , as well as temperature distributions corresponding to loss of coolant condition where  $h = 0$  on surface A.

**SCHEMATIC:**

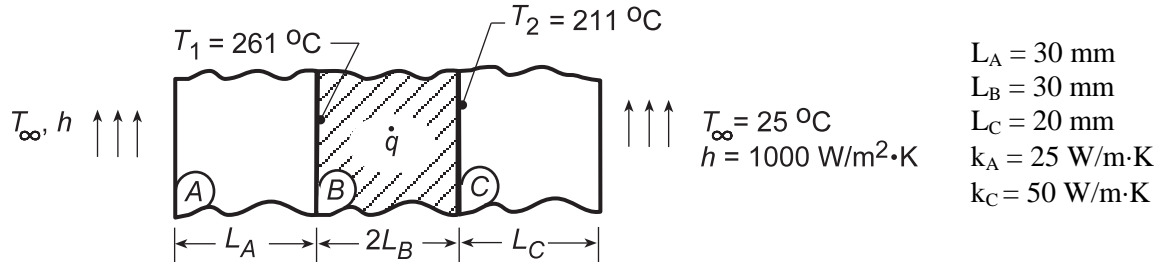

**ASSUMPTIONS:** (1) Steady-state, one-dimensional heat transfer, (2) Negligible contact resistance at interfaces, (3) Uniform generation in B; zero in A and C.

**ANALYSIS:** (a) From an energy balance on wall B,

$$\dot{E}_{in} - \dot{E}_{out} + \dot{E}_g = \dot{E}_{st}$$

$$-q_1'' - q_2'' + 2\dot{q}L_B = 0$$

$$\dot{q}_B = (q_1'' + q_2'')/2L_B \quad (1)$$

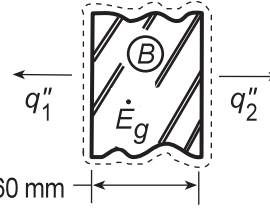

To determine the heat fluxes,  $q_1''$  and  $q_2''$ , construct thermal circuits for A and C:

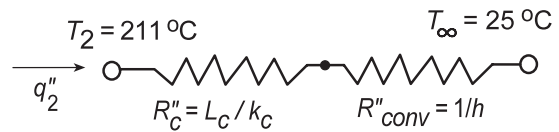
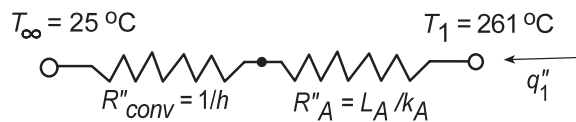

$$q_1'' = (T_1 - T_\infty)/(1/h + L_A/k_A)$$

$$q_2'' = (T_2 - T_\infty)/(L_C/k_C + 1/h)$$

$$q_1'' = (261 - 25)^\circ \text{C} / \left( \frac{1}{1000 \text{ W/m}^2 \cdot \text{K}} + \frac{0.030 \text{ m}}{25 \text{ W/m} \cdot \text{K}} \right)$$

$$q_2'' = (211 - 25)^\circ \text{C} / \left( \frac{0.020 \text{ m}}{50 \text{ W/m} \cdot \text{K}} + \frac{1}{1000 \text{ W/m}^2 \cdot \text{K}} \right)$$

$$q_1'' = 236^\circ \text{C} / (0.001 + 0.0012) \text{ m}^2 \cdot \text{K/W}$$

$$q_2'' = 186^\circ \text{C} / (0.0004 + 0.001) \text{ m}^2 \cdot \text{K/W}$$

$$q_1'' = 107,273 \text{ W/m}^2$$

$$q_2'' = 132,857 \text{ W/m}^2$$

Using the values for  $q_1''$  and  $q_2''$  in Eq. (1), find

$$\dot{q}_B = (106,818 + 132,143 \text{ W/m}^2) / 2 \times 0.030 \text{ m} = 4.00 \times 10^6 \text{ W/m}^3 \quad <$$

To determine  $k_B$ , use the general form of the temperature (Eq. 3.40) and heat flux distributions in wall B,

$$T(x) = -\frac{\dot{q}_B}{2k_B} x^2 + C_1 x + C_2 \quad q_x''(x) = -k_B \left[ -\frac{\dot{q}_B}{k_B} x + C_1 \right] \quad (2,3)$$

there are 3 unknowns,  $C_1$ ,  $C_2$  and  $k_B$ , which can be evaluated using three conditions,

Continued...

### PROBLEM 3.84 (Cont.)

$$T(-L_B) = T_1 = -\frac{\dot{q}_B}{2k_B}(-L_B)^2 - C_1L_B + C_2 \quad \text{where } T_1 = 261^\circ\text{C} \quad (4)$$

$$T(+L_B) = T_2 = -\frac{\dot{q}_B}{2k_B}(+L_B)^2 + C_1L_B + C_2 \quad \text{where } T_2 = 211^\circ\text{C} \quad (5)$$

$$q_x''(-L_B) = -q_1'' = -k_B \left[ -\frac{\dot{q}_B}{k_B}(-L_B) + C_1 \right] \quad \text{where } q_1'' = 107,273 \text{ W/m}^2 \quad (6)$$

Using IHT to solve Eqs. (4), (5) and (6) simultaneously with  $\dot{q}_B = 4.00 \times 10^6 \text{ W/m}^3$ , find

$$k_B = 15.3 \text{ W/m} \cdot \text{K} \quad \leftarrow$$

(b) Following the method of analysis in the *IHT Example 3.6, User-Defined Functions*, the temperature distribution is shown in the plot below. The important features are (1) Distribution is quadratic in B, but non-symmetrical; linear in A and C; (2) Because thermal conductivities of the materials are different, discontinuities exist at each interface; (3) By comparison of gradients at  $x = -L_B$  and  $+L_B$ , find  $q_2'' > q_1''$ .

(c) Using the same method of analysis as for Part (c), the temperature distribution is shown in the plot below when  $h = 0$  on the surface of A. Since the left boundary is adiabatic, material A will be isothermal at  $T_1$ . Find

$$T_1 = 835^\circ\text{C} \quad T_2 = 360^\circ\text{C} \quad \leftarrow$$

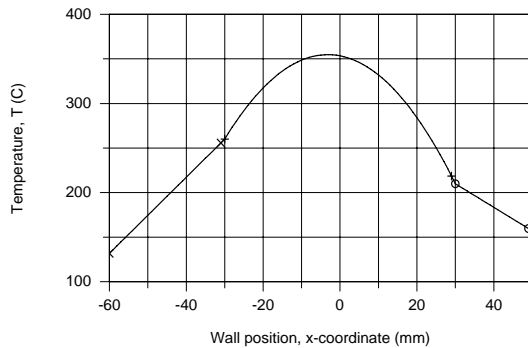

$\times$   $T_{x,A}$ ,  $k_A = 25 \text{ W/m.K}$   
 $+$   $T_{x,B}$ ,  $k_B = 15 \text{ W/m.K}$ ,  $\dot{q}_B = 4.00 \times 10^6 \text{ W/m}^3$   
 $\circ$   $T_{x,C}$ ,  $k_C = 50 \text{ W/m.K}$

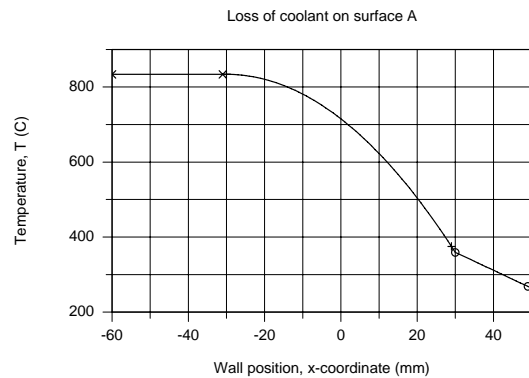

$\times$   $T_{x,A}$ ,  $k_A = 25 \text{ W/m.K}$ ; adiabatic surface  
 $+$   $T_{x,B}$ ,  $k_B = 15 \text{ W/m.K}$ ,  $\dot{q}_B = 4.00 \times 10^6 \text{ W/m}^3$   
 $\circ$   $T_{x,C}$ ,  $k_C = 50 \text{ W/m.K}$



### PROBLEM 3.85

**KNOWN:** Dimensions and properties of a composite wall exposed to convective or insulated conditions.

**FIND:** (a) Maximum wall temperature for left face insulated and right face convectively cooled, (b) Sketch the steady-state temperature distribution of part (a), (c) Sketch the steady-state temperature distribution with reversed boundary conditions.

**SCHEMATIC:**

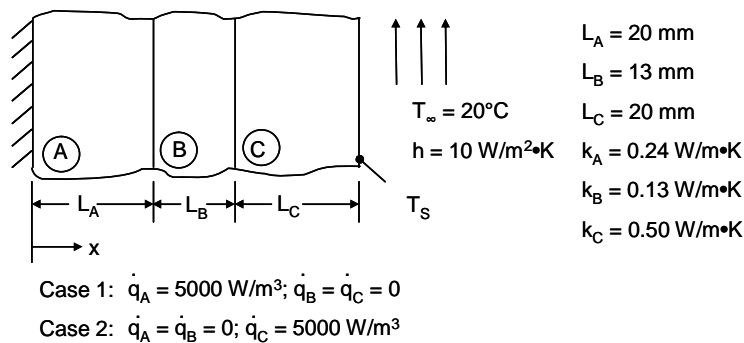

**ASSUMPTIONS:** (1) Steady-state conditions, (2) One-dimensional heat transfer, (3) Uniform volumetric energy generation.

**ANALYSIS:**

(a) The heat flux through materials B and C is constant and is

$$q'' = \dot{q}_A(L_A) = 5000 \text{ W/m}^3 \times 0.02 \text{ m} = 100 \text{ W/m}^2$$

The thermal resistance network that spans from  $x = L_A$  to the coolant is

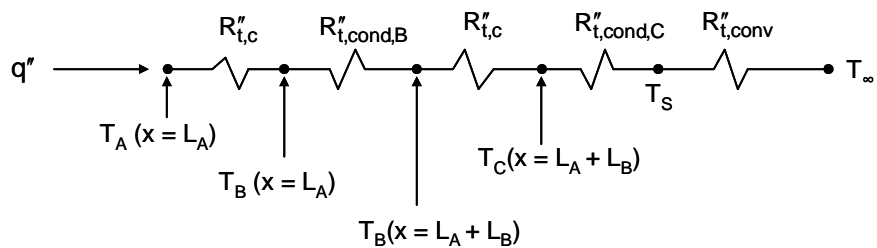

The thermal resistances are:

$$R''_{t,c} = 0.01 \text{ m}^2 \cdot \text{K/W}$$

$$R''_{t,cond,B} = \frac{L_B}{k_B} = \frac{0.013 \text{ m}}{0.13 \text{ W/m}\cdot\text{K}} = 0.1 \frac{\text{m}^2 \cdot \text{K}}{\text{W}}$$

$$R''_{t,cond,C} = \frac{L_C}{k_C} = \frac{0.020 \text{ m}}{0.50 \text{ W/m}\cdot\text{K}} = 0.04 \frac{\text{m}^2 \cdot \text{K}}{\text{W}}$$

Continued...

**PROBLEM 3.85 (Cont.)**

$$R''_{t,\text{conv}} = \frac{1}{h} = \frac{1}{10 \text{ W/m}^2 \cdot \text{K}} = 0.1 \frac{\text{m}^2 \cdot \text{K}}{\text{W}}$$

The total thermal resistance is

$$R''_{t,\text{tot}} = (0.01 + 0.1 + 0.01 + 0.04 + 0.1) = 0.26 \frac{\text{m}^2 \cdot \text{K}}{\text{W}}$$

Therefore,

$$T_A(x=L_A) = q''(R''_{t,\text{tot}}) + T_\infty = 100 \text{ W/m}^2 \times 0.26 \frac{\text{m}^2 \cdot \text{K}}{\text{W}} + 20^\circ\text{C} = 46^\circ\text{C}$$

The maximum temperature occurs at  $x = 0$  and may be evaluated by using Eq. 3.48 as follows

$$T_A(x=0) = T_A(x=L_A) + \frac{\dot{q}_A L_A^2}{2k_A} = 46^\circ\text{C} + \frac{5000 \text{ W/m}^3 \times (0.02 \text{ m})^2}{2 \times 0.24 \text{ W/m} \cdot \text{K}}$$

$$T_A(x=0) = T_{\text{max}} = 50.2^\circ\text{C} \quad <$$

(b) To sketch the temperature distribution, we begin by evaluating the temperatures shown in the thermal resistance network. Working from the coolant side,

$$T_s = T_\infty + q''(R''_{t,\text{conv}}) = 20^\circ\text{C} + 100 \text{ W/m}^2 \times 0.1 \text{ m}^2 \cdot \text{K/W} = 30^\circ\text{C}$$

$$T_C(x = L_A + L_B) = T_s + q''(R''_{t,\text{cond,C}}) = 30^\circ\text{C} + 100 \text{ W/m}^2 \times 0.04 \text{ m}^2 \cdot \text{K/W} = 34^\circ\text{C}$$

$$T_B(x = L_A + L_B) = T_C(x = L_A + L_B) + q''(R''_{t,c}) = 34^\circ\text{C} + 100 \text{ W/m}^2 \times 0.01 \frac{\text{m}^2 \cdot \text{K}}{\text{W}} = 35^\circ\text{C}$$

$$T_B(x = L_A) = T_B(x = L_A + L_B) + q''(R''_{t,\text{cond,B}}) = 35^\circ\text{C} + 100 \text{ W/m}^2 \times 0.1 \text{ m}^2 \cdot \text{K/W} = 45^\circ\text{C}$$

and from part (a),  $T_A(x = L_A) = 46^\circ\text{C}$ . The temperature distribution is sketched below.

(c) For case 2, the heat flux in the range  $0 \leq x \leq L_A + L_B$  is zero. Hence the boundary at  $x = L_A + L_B$  acts as an insulated surface for material C. Therefore, from Eq. 3.43,

$$T_{\text{max}} = T_C(x = L_A + L_B) = T_s + \frac{\dot{q}_C L_C^2}{2k_C} = 30^\circ\text{C} + \frac{5000 \text{ W/m}^3 \times (0.02 \text{ m})^2}{2 \times 0.50 \text{ W/m} \cdot \text{K}} = 32^\circ\text{C}$$

The temperature distribution is sketched below.

Continued...

### PROBLEM 3.85 (Cont.)

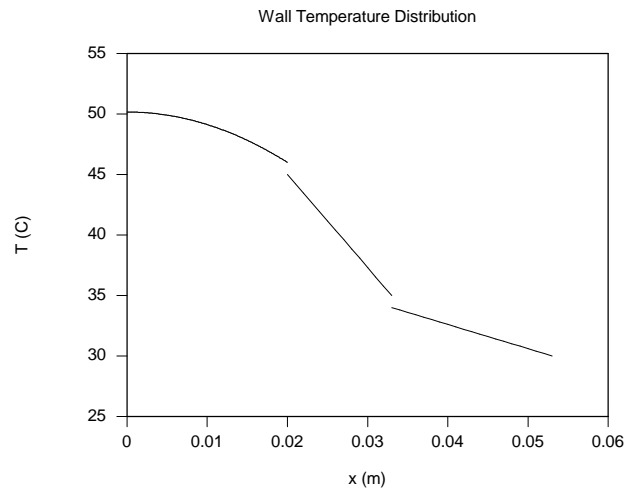

Case 1 temperature distribution.

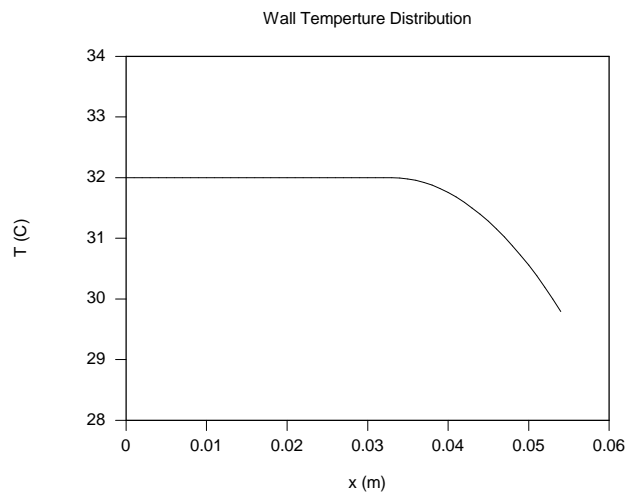

Case 2 temperature distribution.

**COMMENTS:** If the heat flux due to conduction in the x-direction is zero, the temperature gradient,  $dT/dx$ , must be zero. This is a direct consequence of Fourier's law, and holds under all conditions.

### PROBLEM 3.86

**KNOWN:** Diameter, resistivity, thermal conductivity, emissivity, voltage, and maximum temperature of heater wire. Convection coefficient and air exit temperature. Temperature of surroundings.

**FIND:** Maximum operating current, heater length and power rating.

**SCHEMATIC:**

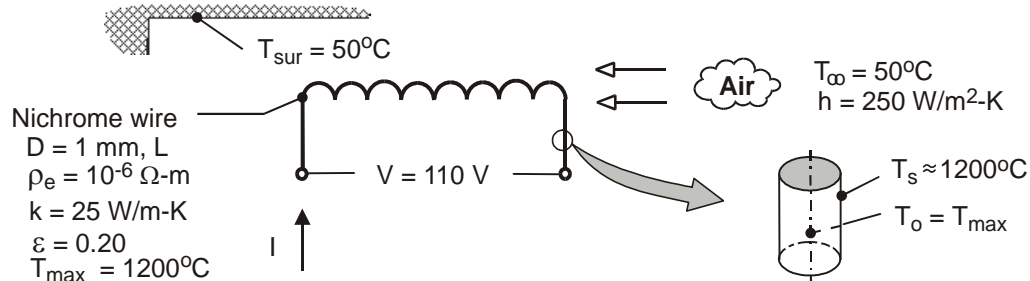

**ASSUMPTIONS:** (1) Steady-state, (2) Uniform wire temperature, (3) Constant properties, (4) Radiation exchange with large surroundings.

**ANALYSIS:** Assuming a uniform wire temperature,  $T_{\max} = T(r=0) \equiv T_o \approx T_s$ , the maximum volumetric heat generation may be obtained from Eq. (3.60), but with the total heat transfer coefficient,  $h_t = h + h_r$ , used in lieu of the convection coefficient  $h$ . With

$$h_r = \varepsilon\sigma(T_s + T_{\text{sur}})(T_s^2 + T_{\text{sur}}^2) = 0.20 \times 5.67 \times 10^{-8} \text{ W/m}^2 \cdot \text{K}^4 (1473 + 323) \text{ K} (1473^2 + 323^2) \text{ K}^2 = 46.3 \text{ W/m}^2 \cdot \text{K}$$

$$h_t = (250 + 46.3) \text{ W/m}^2 \cdot \text{K} = 296.3 \text{ W/m}^2 \cdot \text{K}$$

$$\dot{q}_{\max} = \frac{2h_t}{r_o}(T_s - T_\infty) = \frac{2(296.3 \text{ W/m}^2 \cdot \text{K})}{0.0005 \text{ m}}(1150^\circ\text{C}) = 1.36 \times 10^9 \text{ W/m}^3$$

Hence, with  $\dot{q} = \frac{I^2 R_e}{\forall} = \frac{I^2 (\rho_e L / A_c)}{L A_c} = \frac{I^2 \rho_e}{A_c^2} = \frac{I^2 \rho_e}{(\pi D^2 / 4)^2}$

$$I_{\max} = \left( \frac{\dot{q}_{\max}}{\rho_e} \right)^{1/2} \frac{\pi D^2}{4} = \left( \frac{1.36 \times 10^9 \text{ W/m}^3}{10^{-6} \Omega \cdot \text{m}} \right)^{1/2} \frac{\pi (0.001 \text{ m})^2}{4} = 29.0 \text{ A} \quad <$$

Also, with  $\Delta E = I R_e = I (\rho_e L / A_c)$ ,

$$L = \frac{\Delta E \cdot A_c}{I_{\max} \rho_e} = \frac{110 \text{ V} \left[ \pi (0.001 \text{ m})^2 / 4 \right]}{29.0 \text{ A} (10^{-6} \Omega \cdot \text{m})} = 2.98 \text{ m} \quad <$$

and the power rating is

$$P_{\text{elec}} = \Delta E \cdot I_{\max} = 110 \text{ V} (29 \text{ A}) = 3190 \text{ W} = 3.19 \text{ kW} \quad <$$

**COMMENTS:** To assess the validity of assuming a uniform wire temperature, Eq. (3.58) may be used to compute the centerline temperature corresponding to  $\dot{q}_{\max}$  and a surface temperature of

1200°C. It follows that  $T_o = \frac{\dot{q}_{\max} r_o^2}{4k} + T_s = \frac{1.36 \times 10^9 \text{ W/m}^3 (0.0005 \text{ m})^2}{4(25 \text{ W/m}\cdot\text{K})} + 1200^\circ\text{C} = 1203^\circ\text{C}$ . With only a

3°C temperature difference between the centerline and surface of the wire, the assumption is excellent.

### PROBLEM 3.87

**KNOWN:** Composite wall of materials A and B. Wall of material A has uniform generation, while wall B has no generation. The inner wall of material A is insulated, while the outer surface of material B experiences convection cooling. Thermal contact resistance between the materials is  $R''_{t,c} = 10^{-4} \text{ m}^2 \cdot \text{K/W}$ . See Example 3.7 that considers the case without contact resistance.

**FIND:** Compute and plot the temperature distribution in the composite wall.

**SCHEMATIC:**

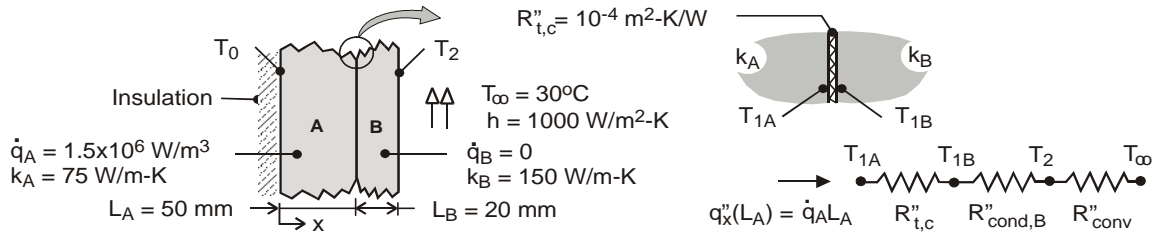

**ASSUMPTIONS:** (1) Steady-state conditions, (2) One-dimensional conduction with constant properties, and (3) Inner surface of material A is adiabatic.

**ANALYSIS:** From the analysis of Example 3.8, we know the temperature distribution in material A is parabolic with zero slope at the inner boundary, and that the distribution in material B is linear. At the interface between the two materials,  $x = L_A$ , the temperature distribution will show a discontinuity.

$$T_A(x) = \frac{\dot{q} L_A^2}{2k_A} \left( 1 - \frac{x^2}{L_A^2} \right) + T_{1A} \quad 0 \leq x \leq L_A$$

$$T_B(x) = T_{1B} - (T_{1B} - T_2) \frac{x - L_A}{L_B} \quad L_A \leq x \leq L_A + L_B$$

Considering the thermal circuit above (see also Example 3.8) including the thermal contact resistance,

$$q'' = \dot{q} L_A = \frac{T_{1A} - T_\infty}{R''_{\text{tot}}} = \frac{T_{1B} - T_\infty}{R''_{\text{cond},B} + R''_{\text{conv}}} = \frac{T_2 - T_\infty}{R''_{\text{conv}}}$$

find  $T_A(0) = 147.5^\circ\text{C}$ ,  $T_{1A} = 122.5^\circ\text{C}$ ,  $T_{1B} = 115^\circ\text{C}$ , and  $T_2 = 105^\circ\text{C}$ . Using the foregoing equations in IHT, the temperature distributions for each of the materials can be calculated and are plotted on the graph below.

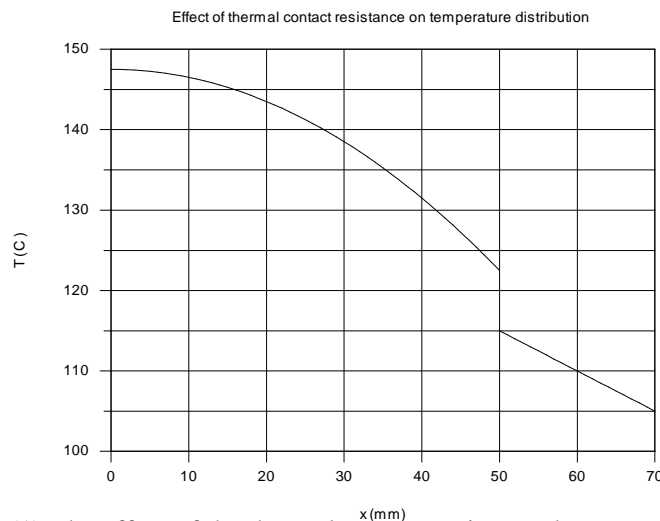

**COMMENTS:** (1) The effect of the thermal contact resistance between the materials is to increase the maximum temperature of the system.

(2) Can you explain why the temperature distribution in the material B is not affected by the presence of the thermal contact resistance at the materials' interface?

### PROBLEM 3.88

**KNOWN:** One dimensional plane wall with uniform thermal energy generation and cold surface temperature  $T_{s,1}$ .

**FIND:** (a) Expression for the heat flux to the cold wall and hot surface temperature, (b) Comparison of the heat flux of part (a) with that associated with a plane wall with no energy generation and wall temperatures of  $T_{s,1}$  and  $T_{s,2}$ .

**SCHEMATIC:**

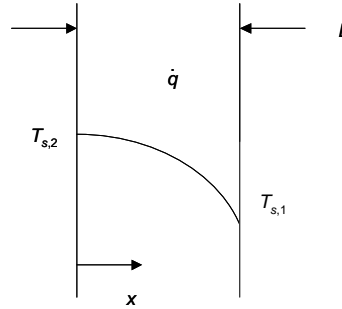

**ASSUMPTIONS:** (1) Steady-state conditions, (2) Constant properties, (3) One-dimensional heat transfer, (4) Uniform volumetric generation.

**ANALYSIS:** From Eq. (3.46) and the discussion beneath Eq. (3.49) the temperature distribution is

$$T(x) = \frac{\dot{q}L^2}{2k} \left( 1 - \frac{x^2}{L^2} \right) + T_{s,1} \quad (1)$$

(a) Equation (1) may be used to find an expression for the temperature gradient

$$\frac{dT(x)}{dx} = \frac{\dot{q}L^2}{2k} \left( -\frac{2x}{L^2} \right) = -\frac{\dot{q}x}{k}$$

Therefore, the heat flux at the cold ( $x = L$ ) surface is

$$q''(x = L) = -k \left. \frac{dT}{dx} \right|_{x=L} = \dot{q}L <$$

The temperature of the hot surface may be found from Eq. (1) and is

$$T_{s,2} = T(x = 0) = \frac{\dot{q}L^2}{2k} + T_{s,1} <$$

(b) For the plane wall without energy generation, and with surface temperatures  $T_{s,1}$  and  $T_{s,2}$ ,

$$q'' = k \frac{(T_{s,2} - T_{s,1})}{L} = k \left( \frac{\frac{\dot{q}L^2}{2k} + T_{s,1} - T_{s,1}}{L} \right) = \frac{\dot{q}L}{2} = \frac{1}{2} q''(x = L) <$$

Hence, the heat flux with uniform thermal energy generation is twice that which would be calculated for a plane wall without energy generation based upon the difference between the actual hot and cold surface temperatures.

### PROBLEM 3.89

**KNOWN:** Plane wall of thickness  $2L$ , thermal conductivity  $k$  with uniform energy generation  $\dot{q}$ . For case 1, boundary at  $x = -L$  is perfectly insulated, while boundary at  $x = +L$  is maintained at  $T_o = 50^\circ\text{C}$ . For case 2, the boundary conditions are the same, but a thin dielectric strip with thermal resistance  $R_t'' = 0.0005 \text{ m}^2 \cdot \text{K}/\text{W}$  is inserted at the mid-plane.

**FIND:** (a) Sketch the temperature distribution for case 1 on  $T$ - $x$  coordinates and describe key features; identify and calculate the maximum temperature in the wall, (b) Sketch the temperature distribution for case 2 on the same  $T$ - $x$  coordinates and describe the key features; (c) What is the temperature difference between the two walls at  $x = 0$  for case 2? And (d) What is the location of the maximum temperature of the composite wall in case 2; calculate this temperature.

**SCHEMATIC:**

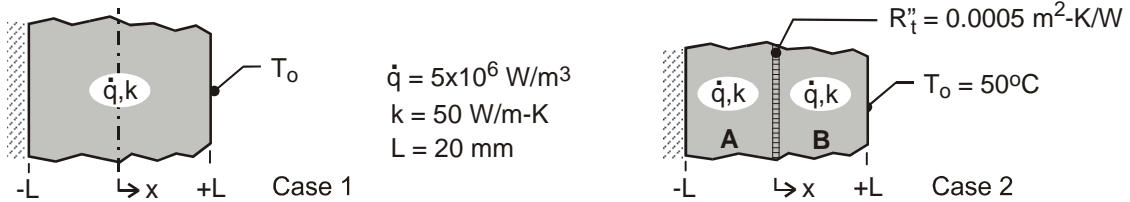

**ASSUMPTIONS:** (1) Steady-state conditions, (2) One-dimensional conduction in the plane and composite walls, and (3) Constant properties.

**ANALYSIS:** (a) For case 1, the temperature distribution,  $T_1(x)$  vs.  $x$ , is parabolic as shown in the schematic below and the gradient is zero at the insulated boundary,  $x = -L$ . From Eq. 3.48 (see discussion after Eq. 3.49),

$$T_1(-L) - T_1(+L) = \frac{\dot{q}(2L)^2}{2k} = \frac{5 \times 10^6 \text{ W/m}^3 (2 \times 0.020 \text{ m})^2}{2 \times 50 \text{ W/m} \cdot \text{K}} = 80^\circ\text{C}$$

and since  $T_1(+L) = T_o = 50^\circ\text{C}$ , the maximum temperature occurs at  $x = -L$ ,

$$T_1(-L) = T_1(+L) + 80^\circ\text{C} = 130^\circ\text{C}$$

(b) For case 2, the temperature distribution,  $T_2(x)$  vs.  $x$ , is piece-wise parabolic, with zero gradient at  $x = -L$  and a drop across the dielectric strip,  $\Delta T_{AB}$ . The temperature gradients at either side of the dielectric strip are equal.

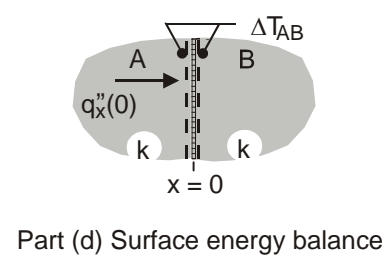
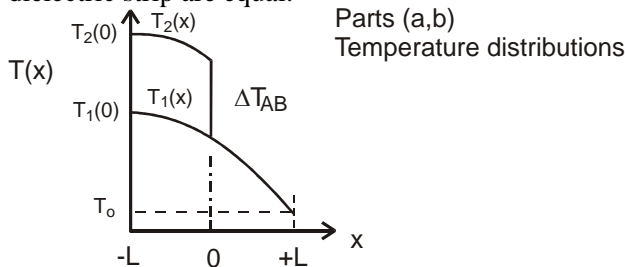

(c) For case 2, the temperature drop across the thin dielectric strip follows from the surface energy balance shown above.

$$q_x''(0) = \Delta T_{AB} / R_t'' \quad q_x''(0) = \dot{q}L$$

$$\Delta T_{AB} = R_t'' \dot{q}L = 0.0005 \text{ m}^2 \cdot \text{K}/\text{W} \times 5 \times 10^6 \text{ W/m}^3 \times 0.020 \text{ m} = 50^\circ\text{C}$$

(d) For case 2, the maximum temperature in the composite wall occurs at  $x = -L$ , with the value,

$$T_2(-L) = T_1(-L) + \Delta T_{AB} = 130^\circ\text{C} + 50^\circ\text{C} = 180^\circ\text{C}$$

<

### PROBLEM 3.90

**KNOWN:** Geometry and boundary conditions of a nuclear fuel element.

**FIND:** (a) Expression for the temperature distribution in the fuel, (b) Form of temperature distribution for the entire system.

**SCHEMATIC:**

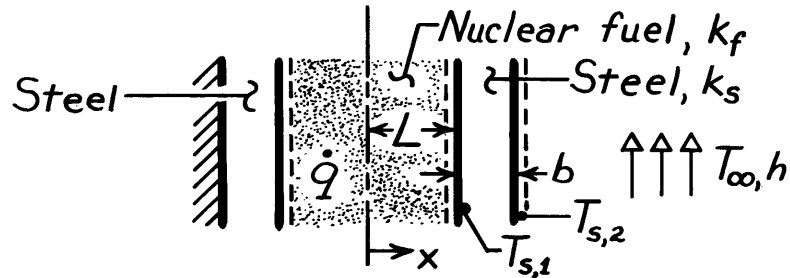

**ASSUMPTIONS:** (1) One-dimensional heat transfer, (2) Steady-state conditions, (3) Uniform generation, (4) Constant properties, (5) Negligible contact resistance between fuel and cladding.

**ANALYSIS:** (a) The general solution to the heat equation, Eq. 3.44,

$$\frac{d^2T}{dx^2} + \frac{\dot{q}}{k_f} = 0 \quad (-L \leq x \leq +L)$$

is 
$$T = -\frac{\dot{q}}{2k_f}x^2 + C_1x + C_2.$$

The insulated wall at  $x = -(L+b)$  dictates that the heat flux at  $x = -L$  is zero (for an energy balance applied to a control volume about the wall,  $\dot{E}_{in} = \dot{E}_{out} = 0$ ). Hence

$$\left. \frac{dT}{dx} \right|_{x=-L} = -\frac{\dot{q}}{k_f}(-L) + C_1 = 0 \quad \text{or} \quad C_1 = -\frac{\dot{q}L}{k_f}$$

$$T = -\frac{\dot{q}}{2k_f}x^2 - \frac{\dot{q}L}{k_f}x + C_2. \quad (1)$$

The value of  $T_{s,1}$  may be determined from the energy conservation requirement that  $\dot{E}_g = \dot{q}_{cond} = \dot{q}_{conv}$ , or on a unit area basis.

$$\dot{q}(2L) = \frac{k_s}{b}(T_{s,1} - T_{s,2}) = h(T_{s,2} - T_\infty).$$

Hence,

$$T_{s,1} = \frac{\dot{q}(2Lb)}{k_s} + T_{s,2} \quad \text{where} \quad T_{s,2} = \frac{\dot{q}(2L)}{h} + T_\infty$$

$$T_{s,1} = \frac{\dot{q}(2Lb)}{k_s} + \frac{\dot{q}(2L)}{h} + T_\infty.$$

Continued ...



**PROBLEM 3.90 (Cont.)**

Hence from Eq. (1),

$$T(L) = T_{s,1} = \frac{\dot{q}(2Lb)}{k_s} + \frac{\dot{q}(2L)}{h} + T_\infty = -\frac{3}{2} \frac{\dot{q}(L^2)}{k_f} + C_2$$

which yields

$$C_2 = T_\infty + \dot{q}L \left[ \frac{2b}{k_s} + \frac{2}{h} + \frac{3}{2} \frac{L}{k_f} \right]$$

Hence, the temperature distribution for  $(-L \leq x \leq +L)$  is

$$T = -\frac{\dot{q}}{2k_f} x^2 - \frac{\dot{q}L}{k_f} x + \dot{q}L \left[ \frac{2b}{k_s} + \frac{2}{h} + \frac{3}{2} \frac{L}{k_f} \right] + T_\infty$$

<

(b) For the temperature distribution shown below,

$$\begin{aligned} (-L-b) \leq x \leq -L: & \quad dT/dx=0, T=T_{max} \\ -L \leq x \leq +L: & \quad |dT/dx| \uparrow \text{ with } \uparrow x \\ +L \leq x \leq +L+b: & \quad (dT/dx) \text{ is const.} \end{aligned}$$

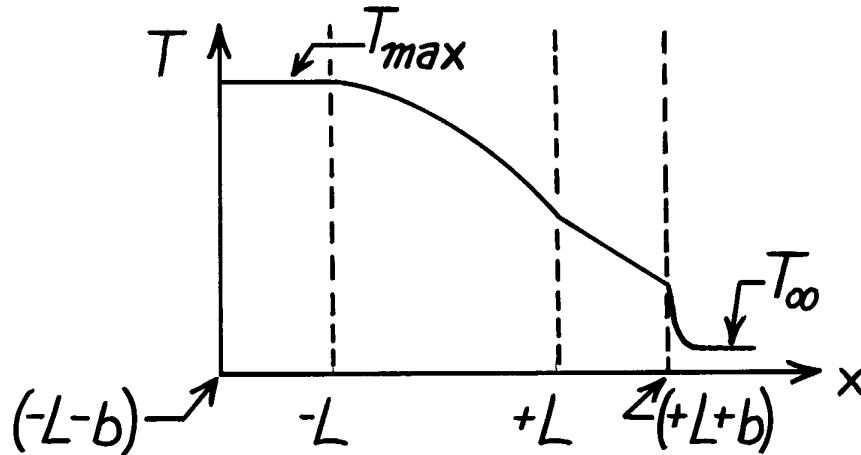

### PROBLEM 3.91

**KNOWN:** Thermal conductivity, heat generation and thickness of fuel element. Thickness and thermal conductivity of cladding. Surface convection conditions.

**FIND:** (a) Temperature distribution in fuel element with one surface insulated and the other cooled by convection. Largest and smallest temperatures and corresponding locations. (b) Same as part (a) but with equivalent convection conditions at both surfaces, (c) Plot of temperature distributions.

**SCHEMATIC:**

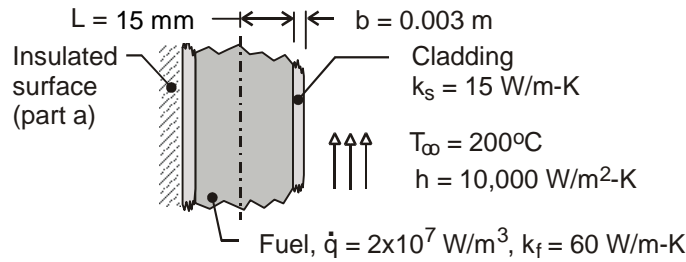

**ASSUMPTIONS:** (1) One-dimensional heat transfer, (2) Steady-state, (3) Uniform generation, (4) Constant properties, (5) Negligible contact resistance.

**ANALYSIS:** (a) From Eq. C.1,

$$T(x) = \frac{\dot{q}L^2}{2k_f} \left( 1 - \frac{x^2}{L^2} \right) + \frac{T_{s,2} - T_{s,1}}{2} \frac{x}{L} + \frac{T_{s,1} + T_{s,2}}{2} \quad (1)$$

With an insulated surface at  $x = -L$ , Eq. C.10 yields

$$T_{s,1} - T_{s,2} = \frac{2\dot{q}L^2}{k_f} \quad (2)$$

and with convection at  $x = L + b$ , Eq. C.13 yields

$$U(T_{s,2} - T_\infty) = \dot{q}L - \frac{k_f}{2L}(T_{s,2} - T_{s,1})$$

$$T_{s,1} - T_{s,2} = \frac{2LU}{k_f}(T_{s,2} - T_\infty) - \frac{2\dot{q}L^2}{k_f} \quad (3)$$

where  $U^{-1} = h^{-1} + b/k_s$ . Subtracting Eq. (2) from Eq. (3),

$$0 = \frac{2LU}{k_f}(T_{s,2} - T_\infty) - \frac{4\dot{q}L^2}{k_f}$$

$$T_{s,2} = T_\infty + \frac{2\dot{q}L}{U} \quad (4)$$

Continued ...

### PROBLEM 3.91 (Cont.)

Alternatively, this result could have been found from an energy balance on the wall which equates the generated heat to the heat leaving at L+b,

$$2\dot{q}L = U(T_{s,2} - T_{\infty})$$

Substituting Eq. (4) into Eq. (2)

$$T_{s,1} = T_{\infty} + 2\dot{q}L \left( \frac{L}{k_f} + \frac{1}{U} \right) \quad (5)$$

Substituting Eqs. (4) and (5) into Eq. (1),

$$T(x) = -\frac{\dot{q}}{2k_f}x^2 - \frac{\dot{q}L}{k_f}x + \dot{q}L \left( \frac{2}{U} + \frac{3L}{2k_f} \right) + T_{\infty}$$

Or,

$$T(x) = -\frac{\dot{q}}{2k_f}x^2 - \frac{\dot{q}L}{k_f}x + \dot{q}L \left( \frac{2b}{k_s} + \frac{2}{h} + \frac{3L}{2k_f} \right) + T_{\infty} \quad (6) <$$

The maximum temperature occurs at  $x = -L$  and is

$$T(-L) = 2\dot{q}L \left( \frac{b}{k_s} + \frac{1}{h} + \frac{L}{k_f} \right) + T_{\infty}$$

$$T(-L) = 2 \times 2 \times 10^7 \text{ W/m}^3 \times 0.015 \text{ m} \left( \frac{0.003 \text{ m}}{15 \text{ W/m} \cdot \text{K}} + \frac{1}{10,000 \text{ W/m}^2 \cdot \text{K}} + \frac{0.015 \text{ m}}{60 \text{ W/m} \cdot \text{K}} \right) + 200^\circ\text{C} = 530^\circ\text{C} <$$

The lowest temperature is at  $x = +L$  and is

$$T(+L) = -\frac{3\dot{q}L^2}{2k_f} + \dot{q}L \left( \frac{2b}{k_s} + \frac{2}{h} + \frac{3L}{2k_f} \right) + T_{\infty} = 380^\circ\text{C} <$$

(b) If a convection condition is maintained at  $x = -L$ , Eq. C.12 reduces to

$$U(T_{\infty} - T_{s,1}) = -\dot{q}L - \frac{k_f}{2L}(T_{s,2} - T_{s,1})$$

$$T_{s,1} - T_{s,2} = \frac{2LU}{k_f}(T_{s,1} - T_{\infty}) - \frac{2\dot{q}L^2}{k_f} \quad (7)$$

Subtracting Eq. (7) from Eq. (3),

$$0 = \frac{2LU}{k_f}(T_{s,2} - T_{\infty} - T_{s,1} + T_{\infty}) \quad \text{or} \quad T_{s,1} = T_{s,2}$$

Hence, from Eq. (7)

Continued ...

**PROBLEM 3.91 (Cont.)**

$$T_{s,1} = T_{s,2} = \frac{\dot{q}L}{U} + T_{\infty} = \dot{q}L \left( \frac{1}{h} + \frac{b}{k_s} \right) + T_{\infty} \quad (8)$$

Substituting into Eq. (1), the temperature distribution is

$$T(x) = \frac{\dot{q}L^2}{2k_f} \left( 1 - \frac{x^2}{L^2} \right) + \dot{q}L \left( \frac{1}{h} + \frac{b}{k_s} \right) + T_{\infty} \quad (9) <$$

The maximum temperature is at  $x = 0$  and is

$$T(0) = \frac{2 \times 10^7 \text{ W/m}^3 (0.015 \text{ m})^2}{2 \times 60 \text{ W/m} \cdot \text{K}} + 2 \times 10^7 \text{ W/m}^3 \times 0.015 \text{ m} \left( \frac{1}{10,000 \text{ W/m}^2 \cdot \text{K}} + \frac{0.003 \text{ m}}{15 \text{ W/m} \cdot \text{K}} \right) + 200^\circ\text{C}$$

$$T(0) = 37.5^\circ\text{C} + 90^\circ\text{C} + 200^\circ\text{C} = 327.5^\circ\text{C} <$$

The minimum temperature at  $x = \pm L$  is

$$T_{s,1} = T_{s,2} = 2 \times 10^7 \text{ W/m}^3 (0.015 \text{ m}) \left( \frac{1}{10,000 \text{ W/m}^2 \cdot \text{K}} + \frac{0.003 \text{ m}}{15 \text{ W/m} \cdot \text{K}} \right) + 200^\circ\text{C} = 290^\circ\text{C} <$$

(c) The temperature distributions are as shown.

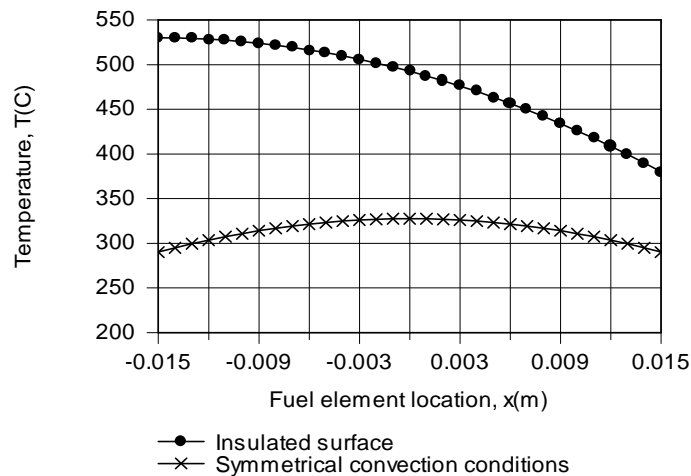

The amount of heat generation is the same for both cases, but the ability to transfer heat from both surfaces for case (b) results in lower temperatures throughout the fuel element.

**COMMENTS:** Note that for case (a), the temperature in the insulated cladding is constant and equivalent to  $T_{s,1} = 530^\circ\text{C}$ .

### PROBLEM 3.92

**KNOWN:** Wall of thermal conductivity  $k$  and thickness  $L$  with uniform generation and strip heater with uniform heat flux  $q''_o$ ; prescribed inside and outside air conditions ( $T_{\infty,i}$ ,  $h_i$ ,  $T_{\infty,o}$ ,  $h_o$ ). Strip heater acts to guard against heat losses from the wall to the outside.

**FIND:** Compute and plot  $q''_o$  and  $T(0)$  as a function of  $\dot{q}$  for  $200 \leq \dot{q} \leq 2000 \text{ W/m}^3$  and  $T_{\infty,i} = 30, 50$  and  $70^\circ\text{C}$ .

**SCHEMATIC:**

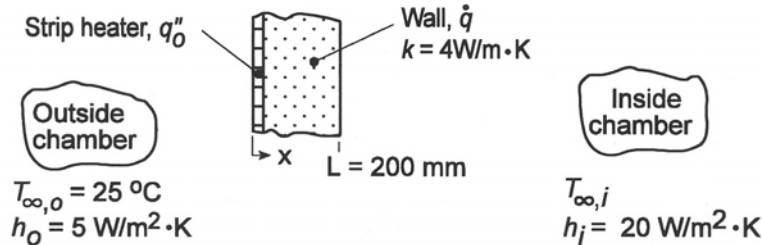

**ASSUMPTIONS:** (1) Steady-state conditions, (2) One-dimensional conduction, (3) Uniform volumetric generation, (4) Constant properties.

**ANALYSIS:** If no heat generated within the wall will be lost to the outside of the chamber, the gradient at the position  $x = 0$  must be zero. Since  $\dot{q}$  is uniform, the temperature distribution must be parabolic as shown in the sketch.

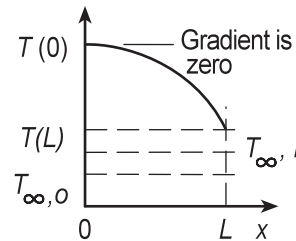

To determine the required heater flux  $q''_o$  as a function of the operation conditions  $\dot{q}$  and  $T_{\infty,i}$ , the analysis begins by considering the temperature distribution in the wall and then surface energy balances at the two wall surfaces. The analysis is organized for easy treatment with equation-solving software.

*Temperature distribution in the wall,  $T(x)$ :* The general solution for the temperature distribution in the wall is, Eq. 3.45,

$$T(x) = -\frac{\dot{q}}{2k}x^2 + C_1x + C_2$$

and the guard condition at the outer wall,  $x = 0$ , requires that the conduction heat flux be zero. Using Fourier's law,

$$q''_x(0) = -k \left. \frac{dT}{dx} \right|_{x=0} = -kC_1 = 0 \quad (C_1 = 0) \quad (1)$$

At the outer wall,  $x = 0$ ,

$$T(0) = C_2 \quad (2)$$

*Heater energy balance,  $x = 0$ :*

$$\dot{E}_{in} + \dot{E}_g - \dot{E}_{out} = 0$$

$$0 + q''_o - q''_{cv,o} - q''_x(0) = 0 \quad (3)$$

$$q''_{cv,o} = h_o(T(0) - T_{\infty,o}), q''_x(0) = 0 \quad (4a,b)$$

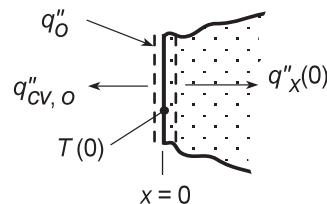

Continued...

**PROBLEM 3.92 (Cont.)**

Surface energy balance,  $x = L$ :

$$\dot{E}_{in} - \dot{E}_{out} = 0$$

$$q_x''(L) - q_{cv,i}'' = 0 \quad (5)$$

$$q_x''(L) = -k \left. \frac{dT}{dx} \right|_{x=L} = +\dot{q}L \quad (6)$$

$$q_{cv,i}'' = h_i [T(L) - T_{\infty,i}]$$

$$q_{cv,i}'' = h_i \left[ -\frac{\dot{q}}{2k} L^2 + T(0) - T_{\infty,i} \right] \quad (7)$$

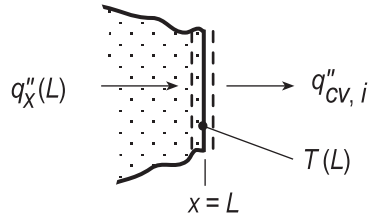

Solving Eqs. (3) through (7) simultaneously with appropriate numerical values and performing the parametric analysis, the results are plotted below.

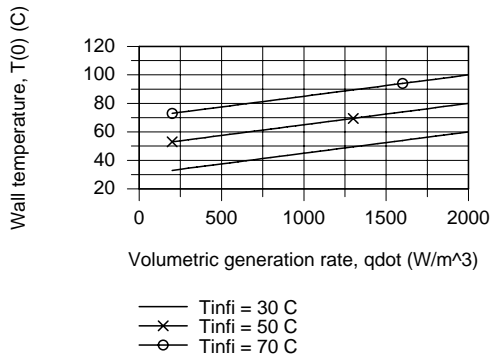
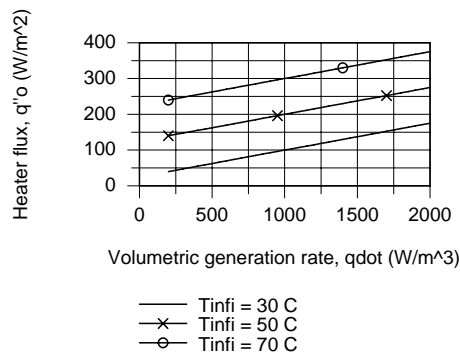

From the first plot, the heater flux  $q_o''$  is a linear function of the volumetric generation rate  $\dot{q}$ . As expected, the higher  $\dot{q}$  and  $T_{\infty,i}$ , the higher the heat flux required to maintain the guard condition ( $q_x''(0) = 0$ ). Notice that for any  $\dot{q}$  condition, equal changes in  $T_{\infty,i}$  result in equal changes in the required  $q_o''$ . The outer wall temperature  $T(0)$  is also linearly dependent upon  $\dot{q}$ . From our knowledge of the temperature distribution, it follows that for any  $\dot{q}$  condition, the outer wall temperature  $T(0)$  will track changes in  $T_{\infty,i}$ .

### PROBLEM 3.93

**KNOWN:** Plane wall with prescribed nonuniform volumetric generation having one boundary insulated and the other isothermal.

**FIND:** Temperature distribution,  $T(x)$ , in terms of  $x$ ,  $L$ ,  $k$ ,  $\dot{q}_0$  and  $T_0$ .

**SCHEMATIC:**

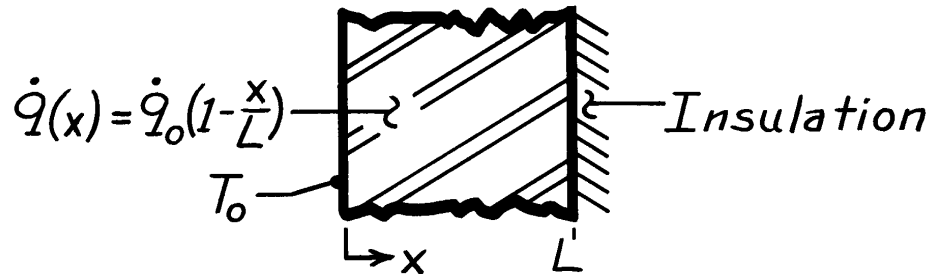

**ASSUMPTIONS:** (1) Steady-state conditions, (2) One-dimensional conduction in  $x$ -direction, (3) Constant properties.

**ANALYSIS:** The appropriate form the heat diffusion equation is

$$\frac{d}{dx} \left[ \frac{dT}{dx} \right] + \frac{\dot{q}}{k} = 0.$$

Noting that  $\dot{q} = \dot{q}(x) = \dot{q}_0 (1 - x/L)$ , substitute for  $\dot{q}(x)$  into the above equation, separate variables and then integrate,

$$d \left[ \frac{dT}{dx} \right] = -\frac{\dot{q}_0}{k} \left[ 1 - \frac{x}{L} \right] dx \quad \frac{dT}{dx} = -\frac{\dot{q}_0}{k} \left[ x - \frac{x^2}{2L} \right] + C_1.$$

Separate variables and integrate again to obtain the general form of the temperature distribution in the wall,

$$dT = -\frac{\dot{q}_0}{k} \left[ x - \frac{x^2}{2L} \right] dx + C_1 dx \quad T(x) = -\frac{\dot{q}_0}{k} \left[ \frac{x^2}{2} - \frac{x^3}{6L} \right] + C_1 x + C_2.$$

Identify the boundary conditions at  $x = 0$  and  $x = L$  to evaluate  $C_1$  and  $C_2$ . At  $x = 0$ ,

$$T(0) = T_0 = -\frac{\dot{q}_0}{k} (0 - 0) + C_1 \cdot 0 + C_2 \quad \text{hence, } C_2 = T_0$$

At  $x = L$ ,

$$\left. \frac{dT}{dx} \right|_{x=L} = 0 = -\frac{\dot{q}_0}{k} \left[ L - \frac{L^2}{2L} \right] + C_1 \quad \text{hence, } C_1 = \frac{\dot{q}_0 L}{2k}$$

The temperature distribution is

$$T(x) = -\frac{\dot{q}_0}{k} \left[ \frac{x^2}{2} - \frac{x^3}{6L} \right] + \frac{\dot{q}_0 L}{2k} x + T_0. \quad <$$

**COMMENTS:** It is good practice to test the final result for satisfying BCs. The heat flux at  $x = 0$  can be found using Fourier's law or from an overall energy balance

$$\dot{E}_{\text{out}} = \dot{E}_g = \int_0^L \dot{q} dV \quad \text{to obtain} \quad q''_{\text{out}} = \dot{q}_0 L/2.$$

### PROBLEM 3.94

**KNOWN:** Distribution of volumetric heating and surface conditions associated with a quartz window.

**FIND:** Temperature distribution in the quartz.

**SCHEMATIC:**

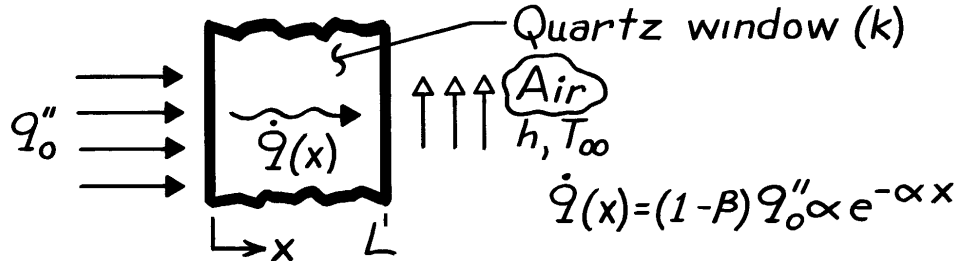

**ASSUMPTIONS:** (1) Steady-state conditions, (2) One-dimensional conduction, (3) Negligible radiation emission and convection at inner surface ( $x = 0$ ) and negligible emission from outer surface, (4) Constant properties.

**ANALYSIS:** The appropriate form of the heat equation for the quartz is obtained by substituting the prescribed form of  $\dot{q}$  into Eq. 3.44.

$$\frac{d^2T}{dx^2} + \frac{\alpha(1-\beta)q_o''}{k} e^{-\alpha x} = 0$$

Integrating,

$$\frac{dT}{dx} = + \frac{(1-\beta)q_o''}{k} e^{-\alpha x} + C_1 \quad T = - \frac{(1-\beta)}{k\alpha} q_o'' e^{-\alpha x} + C_1 x + C_2$$

Boundary Conditions:

$$\begin{aligned} -k \frac{dT}{dx} \Big|_{x=0} &= \beta q_o'' \\ -k \frac{dT}{dx} \Big|_{x=L} &= h [T(L) - T_\infty] \end{aligned}$$

Hence, at  $x = 0$ :

$$\begin{aligned} -k \left[ \frac{(1-\beta)}{k} q_o'' + C_1 \right] &= \beta q_o'' \\ C_1 &= -q_o'' / k \end{aligned}$$

At  $x = L$ :

$$-k \left[ \frac{(1-\beta)}{k} q_o'' e^{-\alpha L} + C_1 \right] = h \left[ - \frac{(1-\beta)}{k\alpha} q_o'' e^{-\alpha L} + C_1 L + C_2 - T_\infty \right]$$

Substituting for  $C_1$  and solving for  $C_2$ ,

$$C_2 = \frac{q_o''}{h} \left[ 1 - (1-\beta) e^{-\alpha L} \right] + \frac{q_o'' L}{k} + \frac{q_o'' (1-\beta)}{k\alpha} e^{-\alpha L} + T_\infty.$$

Hence,

$$T(x) = \frac{(1-\beta)q_o''}{k\alpha} \left[ e^{-\alpha L} - e^{-\alpha x} \right] + \frac{q_o''}{k} (L-x) + \frac{q_o''}{h} \left[ 1 - (1-\beta) e^{-\alpha L} \right] + T_\infty. <$$

**COMMENTS:** The temperature distribution depends strongly on the radiative coefficients,  $\alpha$  and  $\beta$ . For  $\alpha \rightarrow \infty$  or  $\beta = 1$ , the heating occurs entirely at  $x = 0$  (no volumetric heating).



### PROBLEM 3.95

**KNOWN:** Radial distribution of heat dissipation in a cylindrical container of radioactive wastes. Surface convection conditions.

**FIND:** Radial temperature distribution.

**SCHEMATIC:**

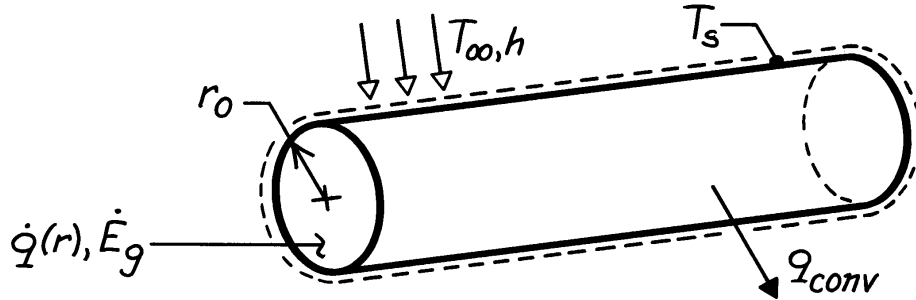

**ASSUMPTIONS:** (1) Steady-state conditions, (2) One-dimensional conduction, (3) Constant properties, (4) Negligible temperature drop across container wall.

**ANALYSIS:** The appropriate form of the heat equation is

$$\frac{1}{r} \frac{d}{dr} \left( r \frac{dT}{dr} \right) = -\frac{\dot{q}}{k} = -\frac{\dot{q}_0}{k} \left( 1 - \frac{r^2}{r_o^2} \right)$$

$$r \frac{dT}{dr} = -\frac{\dot{q}_0 r^2}{2k} + \frac{\dot{q}_0 r^4}{4kr_o^2} + C_1 \quad T = -\frac{\dot{q}_0 r^2}{4k} + \frac{\dot{q}_0 r^4}{16kr_o^2} + C_1 \ln r + C_2.$$

From the boundary conditions,

$$\left. \frac{dT}{dr} \right|_{r=0} = 0 \rightarrow C_1 = 0 \quad -k \left. \frac{dT}{dr} \right|_{r=r_o} = h [T(r_o) - T_\infty]$$

$$+\frac{\dot{q}_0 r_o}{2} - \frac{\dot{q}_0 r_o}{4} = h \left[ -\frac{\dot{q}_0 r_o^2}{4k} + \frac{\dot{q}_0 r_o^2}{16k} + C_2 - T_\infty \right]$$

$$C_2 = \frac{\dot{q}_0 r_o}{4h} + \frac{3\dot{q}_0 r_o^2}{16k} + T_\infty.$$

Hence

$$T(r) = T_\infty + \frac{\dot{q}_0 r_o}{4h} + \frac{\dot{q}_0 r_o^2}{k} \left[ \frac{3}{16} - \frac{1}{4} \left( \frac{r}{r_o} \right)^2 + \frac{1}{16} \left( \frac{r}{r_o} \right)^4 \right]. \quad <$$

**COMMENTS:** Applying the above result at  $r_o$  yields

$$T_s = T(r_o) = T_\infty + (\dot{q}_0 r_o) / 4h$$

The same result may be obtained by applying an energy balance to a control surface about the container, where  $\dot{E}_g = q_{conv}$ . The maximum temperature exists at  $r = 0$ .

### PROBLEM 3.96

**KNOWN:** Cylindrical shell with uniform volumetric generation is insulated at inner surface and exposed to convection on the outer surface.

**FIND:** (a) Temperature distribution in the shell in terms of  $r_i$ ,  $r_o$ ,  $\dot{q}$ ,  $h$ ,  $T_\infty$  and  $k$ , (b) Expression for the heat rate per unit length at the outer radius,  $q'(r_o)$ .

**SCHEMATIC:**

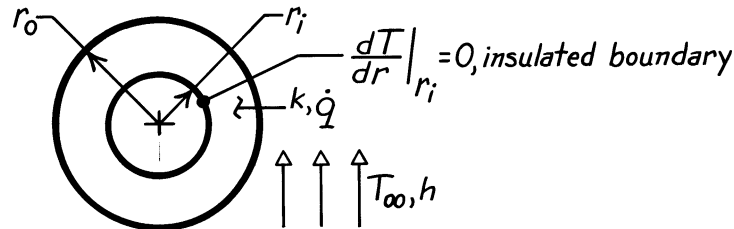

**ASSUMPTIONS:** (1) Steady-state conditions, (2) One-dimensional radial (cylindrical) conduction in shell, (3) Uniform generation, (4) Constant properties.

**ANALYSIS:** (a) The general form of the temperature distribution and boundary conditions are

$$T(r) = -\frac{\dot{q}}{4k} r^2 + C_1 \ln r + C_2$$

$$\text{at } r = r_i: \quad \left. \frac{dT}{dr} \right|_{r_i} = 0 = -\frac{\dot{q}}{2k} r_i + C_1 \frac{1}{r_i} + 0 \quad C_1 = \frac{\dot{q}}{2k} r_i^2$$

$$\text{at } r = r_o: \quad -k \left. \frac{dT}{dr} \right|_{r_o} = h [T(r_o) - T_\infty] \quad \text{surface energy balance}$$

$$-k \left[ -\frac{\dot{q}}{2k} r_o + \left( \frac{\dot{q}}{2k} r_i^2 \cdot \frac{1}{r_o} \right) \right] = h \left[ -\frac{\dot{q}}{4k} r_o^2 + \left( \frac{\dot{q}}{2k} r_i^2 \right) \ln r_o + C_2 - T_\infty \right]$$

$$C_2 = -\frac{\dot{q} r_o}{2h} \left[ 1 - \left( \frac{r_i}{r_o} \right)^2 \right] + \frac{\dot{q} r_o^2}{2k} \left[ \frac{1}{2} - \left( \frac{r_i}{r_o} \right)^2 \ln r_o \right] + T_\infty$$

Hence,

$$T(r) = \frac{\dot{q}}{4k} (r_o^2 - r^2) + \frac{\dot{q} r_i^2}{2k} \ln \left( \frac{r}{r_o} \right) - \frac{\dot{q} r_o}{2h} \left[ 1 - \left( \frac{r_i}{r_o} \right)^2 \right] + T_\infty. \quad <$$

(b) From an overall energy balance on the shell,

$$q'_r(r_o) = \dot{E}'_g = \dot{q} \pi (r_o^2 - r_i^2). \quad <$$

Alternatively, the heat rate may be found using Fourier's law and the temperature distribution,

$$q'_r(r) = -k (2\pi r_o) \left. \frac{dT}{dr} \right|_{r_o} = -2\pi k r_o \left[ -\frac{\dot{q}}{2k} r_o + \frac{\dot{q} r_i^2}{2k} \frac{1}{r_o} + 0 + 0 \right] = \dot{q} \pi (r_o^2 - r_i^2)$$

### PROBLEM 3.97

**KNOWN:** Energy generation in an aluminum-clad, thorium fuel rod under specified operating conditions.

**FIND:** (a) Whether prescribed operating conditions are acceptable, (b) Effect of  $\dot{q}$  and  $h$  on acceptable operating conditions.

**SCHEMATIC:**

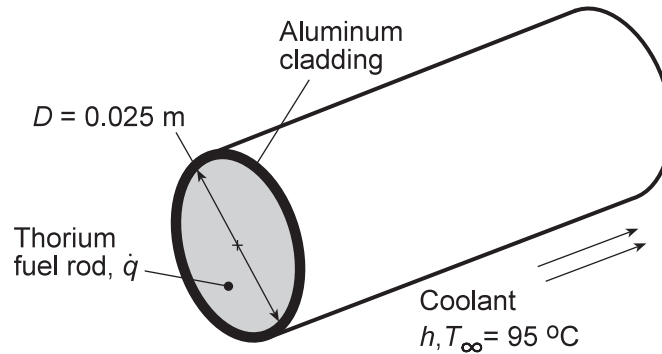

**ASSUMPTIONS:** (1) One-dimensional conduction in  $r$ -direction, (2) Steady-state conditions, (3) Constant properties, (4) Negligible temperature gradients in aluminum and contact resistance between aluminum and thorium.

**PROPERTIES:** *Table A-1*, Aluminum, pure: M.P. = 933 K; *Table A-1*, Thorium: M.P. = 2023 K,  $k \approx 60 \text{ W/m}\cdot\text{K}$ .

**ANALYSIS:** (a) System failure would occur if the melting point of either the thorium or the aluminum were exceeded. From Eq. 3.58, the maximum thorium temperature, which exists at  $r = 0$ , is

$$T(0) = \frac{\dot{q}r_0^2}{4k} + T_s = T_{\text{Th,max}}$$

where, from the energy balance equation, Eq. 3.60, the surface temperature, which is also the aluminum temperature, is

$$T_s = T_\infty + \frac{\dot{q}r_0}{2h} = T_{\text{Al}}$$

Hence,

$$T_{\text{Al}} = T_s = 95^\circ\text{C} + \frac{7 \times 10^8 \text{ W/m}^3 \times 0.0125 \text{ m}}{14,000 \text{ W/m}^2 \cdot \text{K}} = 720^\circ\text{C} = 993 \text{ K}$$

$$T_{\text{Th,max}} = \frac{7 \times 10^8 \text{ W/m}^3 (0.0125 \text{ m})^2}{4 \times 60 \text{ W/m}\cdot\text{K}} + 993 \text{ K} = 1449 \text{ K} \quad <$$

Although  $T_{\text{Th,max}} < \text{M.P.}_{\text{Th}}$  and the thorium would not melt,  $T_{\text{Al}} > \text{M.P.}_{\text{Al}}$  and the cladding would melt under the proposed operating conditions. The problem could be eliminated by *decreasing*  $\dot{q}$  or  $r_0$ , *increasing*  $h$  or using a cladding material with a higher melting point.

(b) Using the one-dimensional, steady-state conduction model (solid cylinder) of the IHT software, the following radial temperature distributions were obtained for parametric variations in  $\dot{q}$  and  $h$ .

Continued...

### PROBLEM 3.97 (Cont.)

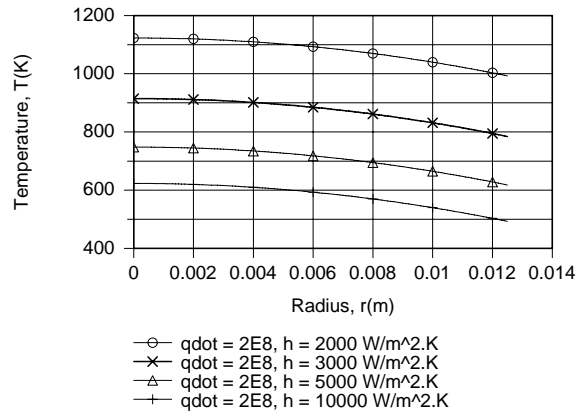
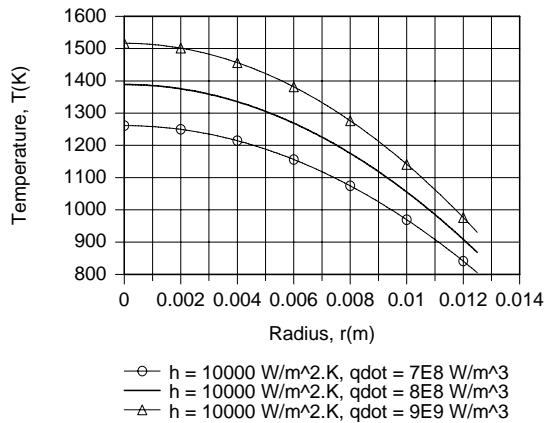

For  $h = 10,000 \text{ W/m}^2 \cdot \text{K}$ , which represents a reasonable upper limit with water cooling, the temperature of the aluminum would be well below its melting point for  $\dot{q} = 7 \times 10^8 \text{ W/m}^3$ , but would be close to the melting point for  $\dot{q} = 8 \times 10^8 \text{ W/m}^3$  and would exceed it for  $\dot{q} = 9 \times 10^8 \text{ W/m}^3$ . Hence, under the best of conditions,  $\dot{q} \approx 7 \times 10^8 \text{ W/m}^3$  corresponds to the maximum allowable energy generation. However, if coolant flow conditions are constrained to provide values of  $h < 10,000 \text{ W/m}^2 \cdot \text{K}$ , volumetric heating would have to be reduced. Even for  $\dot{q}$  as low as  $2 \times 10^8 \text{ W/m}^3$ , operation could not be sustained for  $h = 2000 \text{ W/m}^2 \cdot \text{K}$ .

The effects of  $\dot{q}$  and  $h$  on the centerline and surface temperatures are shown below.

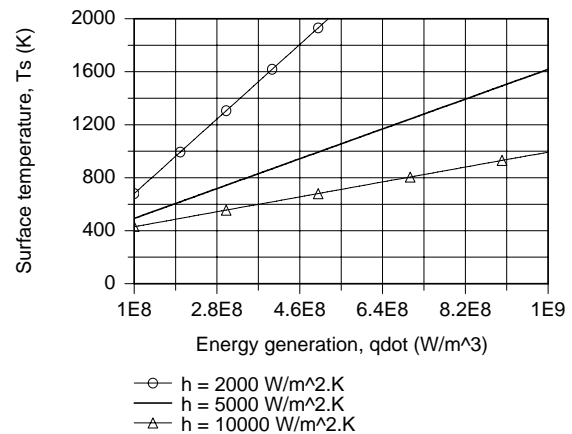
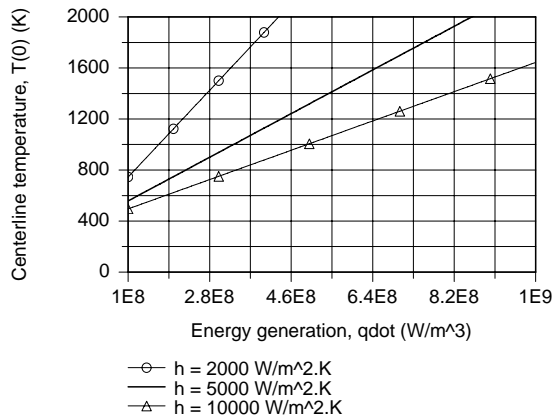

For  $h = 2000$  and  $5000 \text{ W/m}^2 \cdot \text{K}$ , the melting point of thorium would be approached for  $\dot{q} \approx 4.4 \times 10^8$  and  $8.5 \times 10^8 \text{ W/m}^3$ , respectively. For  $h = 2000, 5000$  and  $10,000 \text{ W/m}^2 \cdot \text{K}$ , the melting point of aluminum would be approached for  $\dot{q} \approx 1.6 \times 10^8, 4.3 \times 10^8$  and  $8.7 \times 10^8 \text{ W/m}^3$ . Hence, the envelope of acceptable operating conditions must call for a reduction in  $\dot{q}$  with decreasing  $h$ , from a maximum of  $\dot{q} \approx 7 \times 10^8 \text{ W/m}^3$  for  $h = 10,000 \text{ W/m}^2 \cdot \text{K}$ .

**COMMENTS:** Note the problem which would arise in the event of a *loss of coolant*, for which case  $h$  would *decrease* drastically.

### PROBLEM 3.98

**KNOWN:** Radii and thermal conductivities of reactor fuel element and cladding. Fuel heat generation rate. Temperature and convection coefficient of coolant.

**FIND:** (a) Expressions for temperature distributions in fuel and cladding, (b) Maximum fuel element temperature for prescribed conditions, (c) Effect of  $h$  on temperature distribution.

**SCHEMATIC:**

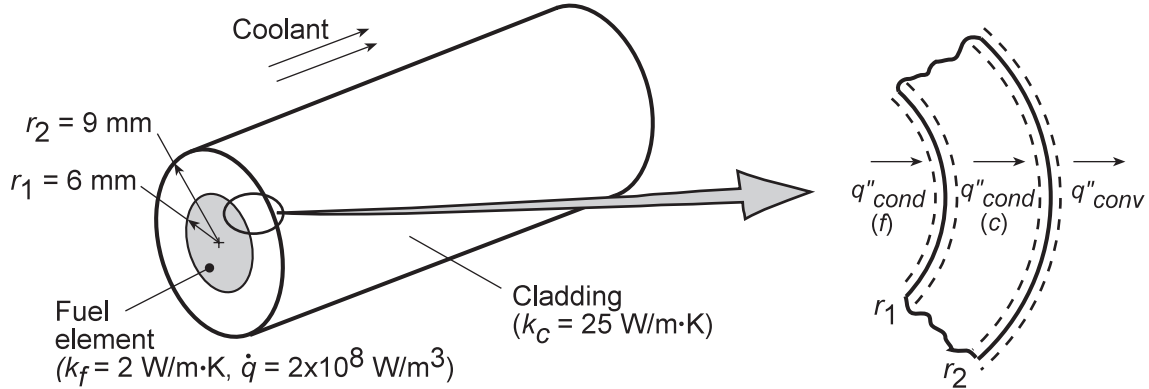

**ASSUMPTIONS:** (1) Steady-state conditions, (2) One-dimensional conduction, (3) Negligible contact resistance, (4) Constant properties.

**ANALYSIS:** (a) From Eqs. 3.54 and 3.28, the heat equations for the fuel (f) and cladding (c) are

$$\frac{1}{r} \frac{d}{dr} \left( r \frac{dT_f}{dr} \right) = -\frac{\dot{q}}{k_f} \quad (0 \leq r \leq r_1) \quad \frac{1}{r} \frac{d}{dr} \left( r \frac{dT_c}{dr} \right) = 0 \quad (r_1 \leq r \leq r_2)$$

Hence, integrating both equations twice,

$$\frac{dT_f}{dr} = -\frac{\dot{q}r}{2k_f} + \frac{C_1}{k_f r} \quad T_f = -\frac{\dot{q}r^2}{4k_f} + \frac{C_1}{k_f} \ln r + C_2 \quad (1,2)$$

$$\frac{dT_c}{dr} = \frac{C_3}{k_c r} \quad T_c = \frac{C_3}{k_c} \ln r + C_4 \quad (3,4)$$

The corresponding boundary conditions are:

$$\left. \frac{dT_f}{dr} \right|_{r=0} = 0 \quad T_f(r_1) = T_c(r_1) \quad (5,6)$$

$$\left. -k_f \frac{dT_f}{dr} \right|_{r=r_1} = \left. -k_c \frac{dT_c}{dr} \right|_{r=r_1} \quad \left. -k_c \frac{dT_c}{dr} \right|_{r=r_2} = h[T_c(r_2) - T_\infty] \quad (7,8)$$

Note that Eqs. (7) and (8) are obtained from surface energy balances at  $r_1$  and  $r_2$ , respectively. Applying Eq. (5) to Eq. (1), it follows that  $C_1 = 0$ . Hence,

$$T_f = -\frac{\dot{q}r^2}{4k_f} + C_2 \quad (9)$$

From Eq. (6), it follows that

$$-\frac{\dot{q}r_1^2}{4k_f} + C_2 = \frac{C_3 \ln r_1}{k_c} + C_4 \quad (10)$$

Continued...

### PROBLEM 3.98 (Cont.)

Also, from Eq. (7),

$$\frac{\dot{q}r_1}{2} = -\frac{C_3}{r_1} \quad \text{or} \quad C_3 = -\frac{\dot{q}r_1^2}{2} \quad (11)$$

Finally, from Eq. (8),  $-\frac{C_3}{r_2} = h \left[ \frac{C_3}{k_c} \ln r_2 + C_4 - T_\infty \right]$  or, substituting for  $C_3$  and solving for  $C_4$

$$C_4 = \frac{\dot{q}r_1^2}{2r_2h} + \frac{\dot{q}r_1^2}{2k_c} \ln r_2 + T_\infty \quad (12)$$

Substituting Eqs. (11) and (12) into (10), it follows that

$$C_2 = \frac{\dot{q}r_1^2}{4k_f} - \frac{\dot{q}r_1^2}{2k_c} \ln r_1 + \frac{\dot{q}r_1^2}{2r_2h} + \frac{\dot{q}r_1^2}{2k_c} \ln r_2 + T_\infty$$

$$C_2 = \frac{\dot{q}r_1^2}{4k_f} + \frac{\dot{q}r_1^2}{2k_c} \ln \frac{r_2}{r_1} + \frac{\dot{q}r_1^2}{2r_2h} + T_\infty \quad (13)$$

Substituting Eq. (13) into (9),

$$T_f = \frac{\dot{q}}{4k_f} (r_1^2 - r^2) + \frac{\dot{q}r_1^2}{2k_c} \ln \frac{r_2}{r_1} + \frac{\dot{q}r_1^2}{2r_2h} + T_\infty \quad (14) <$$

Substituting Eqs. (11) and (12) into (4),

$$T_c = \frac{\dot{q}r_1^2}{2k_c} \ln \frac{r_2}{r} + \frac{\dot{q}r_1^2}{2r_2h} + T_\infty \quad (15) <$$

(b) Applying Eq. (14) at  $r = 0$ , the maximum fuel temperature for  $h = 2000 \text{ W/m}^2 \cdot \text{K}$  is

$$T_f(0) = \frac{2 \times 10^8 \text{ W/m}^3 \times (0.006 \text{ m})^2}{4 \times 2 \text{ W/m} \cdot \text{K}} + \frac{2 \times 10^8 \text{ W/m}^3 \times (0.006 \text{ m})^2}{2 \times 25 \text{ W/m} \cdot \text{K}} \ln \frac{0.009 \text{ m}}{0.006 \text{ m}}$$

$$+ \frac{2 \times 10^8 \text{ W/m}^3 (0.006 \text{ m})^2}{2 \times (0.009 \text{ m}) 2000 \text{ W/m}^2 \cdot \text{K}} + 300 \text{ K}$$

$$T_f(0) = (900 + 58.4 + 200 + 300) \text{ K} = 1458 \text{ K} \quad <$$

(c) Temperature distributions for the prescribed values of  $h$  are as follows:

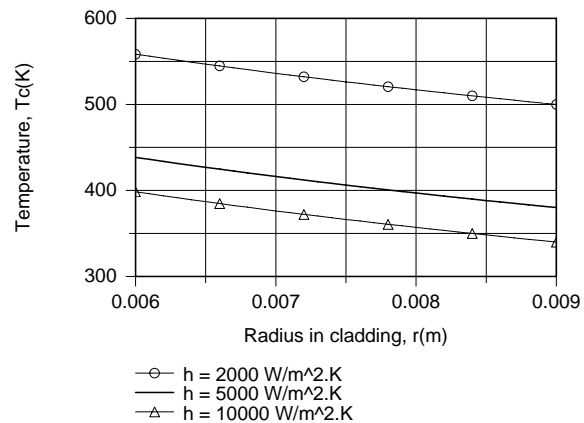
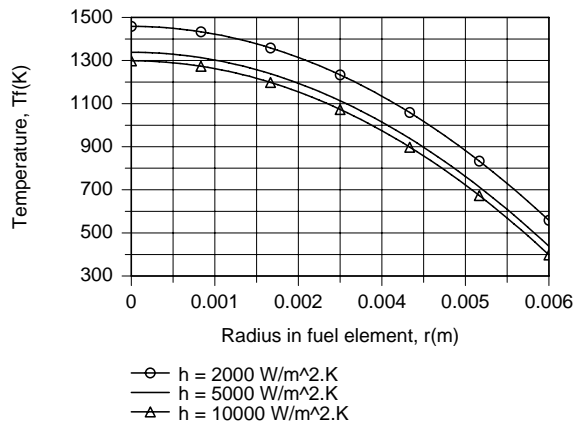

Continued...

### PROBLEM 3.98 (Cont.)

Clearly, the ability to control the maximum fuel temperature by increasing  $h$  is limited, and even for  $h \rightarrow \infty$ ,  $T_f(0)$  exceeds 1000 K. The overall temperature drop,  $T_f(0) - T_\infty$ , is influenced principally by the low thermal conductivity of the fuel material.

**COMMENTS:** For the prescribed conditions, Eq. (14) yields,  $T_f(0) - T_f(r_1) = \dot{q}r_1^2 / 4k_f = (2 \times 10^8 \text{ W/m}^3)(0.006 \text{ m})^2 / 8 \text{ W/m}\cdot\text{K} = 900 \text{ K}$ , in which case, with no cladding and  $h \rightarrow \infty$ ,  $T_f(0) = 1200 \text{ K}$ . To reduce  $T_f(0)$  below 1000 K for the prescribed material, it is necessary to reduce  $\dot{q}$ .

### PROBLEM 3.99

**KNOWN:** Dimensions and properties of tubular heater and external insulation. Internal and external convection conditions. Maximum allowable tube temperature.

**FIND:** (a) Maximum allowable heater current for adiabatic outer surface, (3) Effect of internal convection coefficient on heater temperature distribution, (c) Extent of heat loss at outer surface.

**SCHEMATIC:**

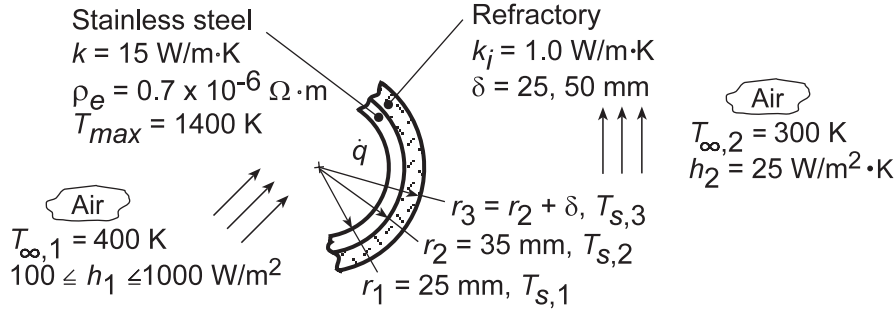

**ASSUMPTIONS:** (1) One-dimensional, steady-state conditions, (2) Constant properties, (3) Uniform heat generation, (4) Negligible radiation at outer surface, (5) Negligible contact resistance.

**ANALYSIS:** (a) From Eqs. 7 and 10, respectively, of Example 3.8, we know that

$$T_{s,2} - T_{s,1} = \frac{\dot{q}}{2k} r_2^2 \ln \frac{r_2}{r_1} - \frac{\dot{q}}{4k} (r_2^2 - r_1^2) \quad (1)$$

and

$$T_{s,1} = T_{\infty,1} + \frac{\dot{q} (r_2^2 - r_1^2)}{2h_1 r_1} \quad (2)$$

Hence, eliminating  $T_{s,1}$ , we obtain

$$T_{s,2} - T_{\infty,1} = \frac{\dot{q} r_2^2}{2k} \left[ \ln \frac{r_2}{r_1} - \frac{1}{2} \left( 1 - r_1^2 / r_2^2 \right) + \frac{k}{h_1 r_1} \left( 1 - r_1^2 / r_2^2 \right) \right]$$

Substituting the prescribed conditions ( $h_1 = 100 \text{ W/m}^2 \cdot \text{K}$ ),

$$T_{s,2} - T_{\infty,1} = 1.237 \times 10^{-4} \left( \text{m}^3 \cdot \text{K/W} \right) \dot{q} \left( \text{W/m}^3 \right)$$

Hence, with  $T_{\text{max}}$  corresponding to  $T_{s,2}$ , the maximum allowable value of  $\dot{q}$  is

$$\dot{q}_{\text{max}} = \frac{1400 - 400}{1.237 \times 10^{-4}} = 8.084 \times 10^6 \text{ W/m}^3$$

with

$$\dot{q} = \frac{I^2 \text{Re}}{\forall} = \frac{I^2 \rho_e L / A_c}{L A_c} = \frac{\rho_e I^2}{\left[ \pi (r_2^2 - r_1^2) \right]^2}$$

$$I_{\text{max}} = \pi (r_2^2 - r_1^2) \left( \frac{\dot{q}}{\rho_e} \right)^{1/2} = \pi (0.035^2 - 0.025^2) \text{m}^2 \left( \frac{8.084 \times 10^6 \text{ W/m}^3}{0.7 \times 10^{-6} \Omega \cdot \text{m}} \right)^{1/2} = 6406 \text{ A} <$$

Continued ...



### PROBLEM 3.99 (Cont.)

(b) Using the one-dimensional, steady-state conduction model of *IHT* (hollow cylinder; convection at inner surface and adiabatic outer surface), the following temperature distributions were obtained.

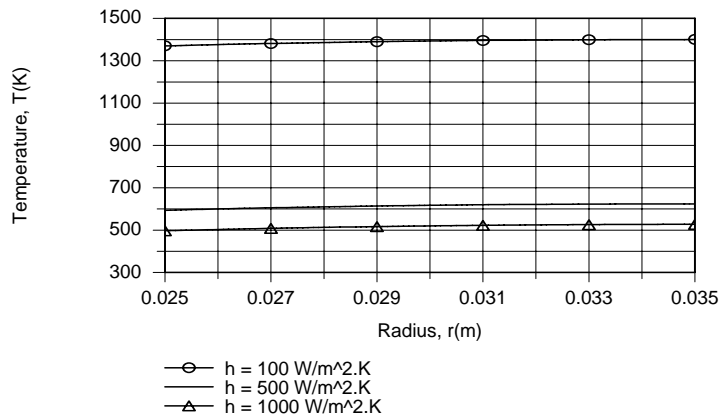

The results are consistent with key implications of Eqs. (1) and (2), namely that the value of  $h_1$  has no effect on the temperature drop across the tube ( $T_{s,2} - T_{s,1} = 30$  K, irrespective of  $h_1$ ), while  $T_{s,1}$  decreases with increasing  $h_1$ . For  $h_1 = 100, 500$  and  $1000$  W/m<sup>2</sup>.K, respectively, the ratio of the temperature drop between the inner surface and the air to the temperature drop across the tube,  $(T_{s,1} - T_{\infty,1})/(T_{s,2} - T_{s,1})$ , decreases from  $970/30 = 32.3$  to  $194/30 = 6.5$  and  $97/30 = 3.2$ . Because the outer surface is insulated, the heat rate to the airflow is fixed by the value of  $\dot{q}$  and, irrespective of  $h_1$ ,

$$q'(r_1) = \pi(r_2^2 - r_1^2)\dot{q} = -15,240 \text{ W} \quad \leftarrow$$

(c) Heat loss from the outer surface of the tube to the surroundings depends on the total thermal resistance

$$R_{\text{tot}} = \frac{\ln(r_3/r_2)}{2\pi L k_i} + \frac{1}{2\pi r_3 L h_2}$$

or, for a unit area on surface 2,

$$R''_{\text{tot},2} = (2\pi r_2 L) R_{\text{tot}} = \frac{r_2 \ln(r_3/r_2)}{k_i} + \frac{r_2}{r_3 h_2}$$

Again using the capabilities of *IHT* (hollow cylinder; convection at inner surface and heat transfer from outer surface through  $R''_{\text{tot},2}$ ), the following temperature distributions were determined for the tube and insulation.

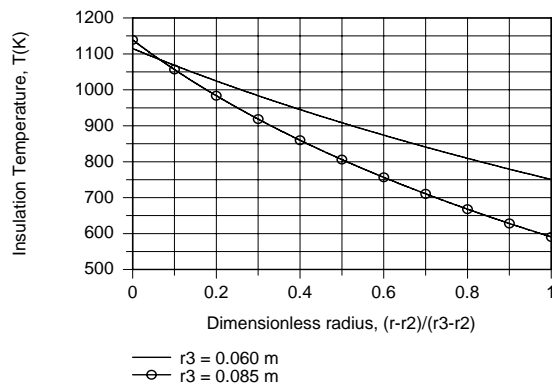
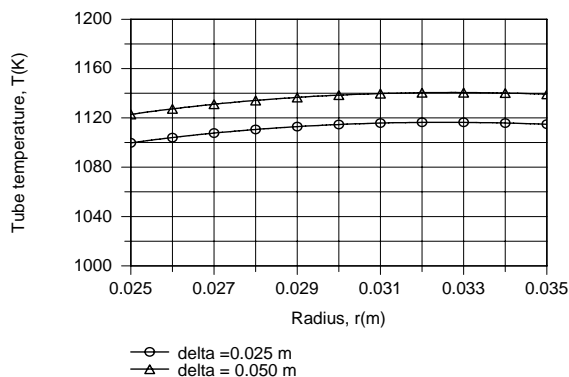

Continued...

### PROBLEM 3.99 (Cont.)

Heat losses through the insulation,  $q'(r_2)$ , are 4250 and 3890 W/m for  $\delta = 25$  and 50 mm, respectively, with corresponding values of  $q'(r_1)$  equal to -10,990 and -11,350 W/m. Comparing the tube temperature distributions with those predicted for an adiabatic outer surface, it is evident that the losses reduce tube wall temperatures predicted for the adiabatic surface and also shift the maximum temperature from  $r = 0.035$  m to  $r \approx 0.033$  m. Although the tube outer and insulation inner surface temperatures,  $T_{s,2} = T(r_2)$ , increase with increasing insulation thickness, Fig. (c), the insulation outer surface temperature decreases.

**COMMENTS:** If the intent is to maximize heat transfer to the airflow, heat losses to the ambient should be reduced by selecting an insulation material with a significantly smaller thermal conductivity.

### PROBLEM 3.100

**KNOWN:** Materials, dimensions, properties and operating conditions of a gas-cooled nuclear reactor.

**FIND:** (a) Inner and outer surface temperatures of fuel element, (b) Temperature distributions for different heat generation rates and maximum allowable generation rate.

**SCHEMATIC:**

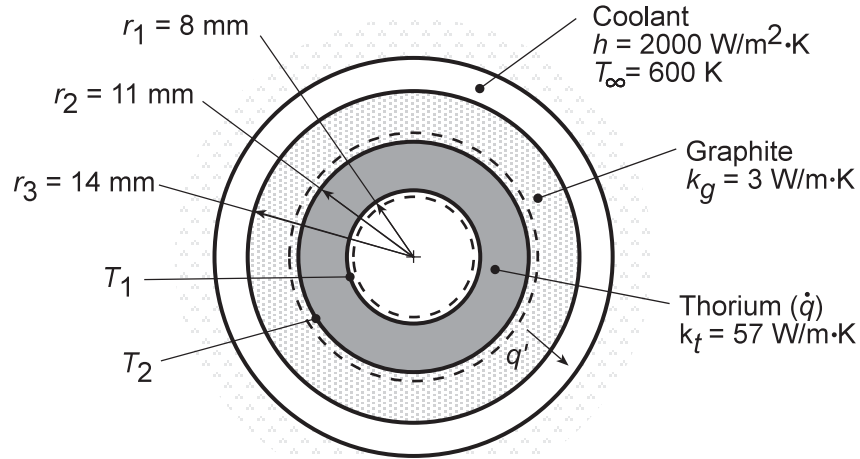

**ASSUMPTIONS:** (1) Steady-state conditions, (2) One-dimensional conduction, (3) Constant properties, (4) Negligible contact resistance, (5) Negligible radiation.

**PROPERTIES:** Table A.1, Thorium:  $T_{mp} \approx 2000$  K; Table A.2, Graphite:  $T_{mp} \approx 2300$  K.

**ANALYSIS:** (a) The outer surface temperature of the fuel,  $T_2$ , may be determined from the rate equation

$$q' = \frac{T_2 - T_\infty}{R'_{tot}}$$

where

$$R'_{tot} = \frac{\ln(r_3/r_2)}{2\pi k_g} + \frac{1}{2\pi r_3 h} = \frac{\ln(14/11)}{2\pi(3 \text{ W/m}\cdot\text{K})} + \frac{1}{2\pi(0.014 \text{ m})(2000 \text{ W/m}^2\cdot\text{K})} = 0.0185 \text{ m}\cdot\text{K/W}$$

and the heat rate per unit length may be determined by applying an energy balance to a control surface about the fuel element. Since the interior surface of the element is essentially adiabatic, it follows that

$$q' = \dot{q}\pi(r_2^2 - r_1^2) = 10^8 \text{ W/m}^3 \times \pi(0.011^2 - 0.008^2) \text{ m}^2 = 17,907 \text{ W/m}$$

Hence,

$$T_2 = q'R'_{tot} + T_\infty = 17,907 \text{ W/m}(0.0185 \text{ m}\cdot\text{K/W}) + 600 \text{ K} = 931 \text{ K} \quad <$$

With zero heat flux at the inner surface of the fuel element, Eq. C.14 yields

$$T_1 = T_2 + \frac{\dot{q}r_2^2}{4k_t} \left(1 - \frac{r_1^2}{r_2^2}\right) - \frac{\dot{q}r_1^2}{2k_t} \ln\left(\frac{r_2}{r_1}\right)$$

$$T_1 = 931 \text{ K} + \frac{10^8 \text{ W/m}^3 (0.011 \text{ m})^2}{4 \times 57 \text{ W/m}\cdot\text{K}} \left[1 - \left(\frac{0.008}{0.011}\right)^2\right] - \frac{10^8 \text{ W/m}^3 (0.008 \text{ m})^2}{2 \times 57 \text{ W/m}\cdot\text{K}} \ln\left(\frac{0.011}{0.008}\right)$$

Continued...

### PROBLEM 3.100 (Cont.)

$$T_1 = 931\text{ K} + 25\text{ K} - 18\text{ K} = 938\text{ K}$$

<

(b) The temperature distributions may be obtained by using the IHT model for one-dimensional, steady-state conduction in a hollow tube. For the fuel element ( $\dot{q} > 0$ ), an adiabatic surface condition is prescribed at  $r_1$ , while heat transfer from the outer surface at  $r_2$  to the coolant is governed by the thermal resistance  $R''_{\text{tot},2} = 2\pi r_2 R'_{\text{tot}} = 2\pi(0.011\text{ m})0.0185\text{ m}\cdot\text{K}/\text{W} = 0.00128\text{ m}^2\cdot\text{K}/\text{W}$ . For the graphite ( $\dot{q} = 0$ ), the value of  $T_2$  obtained from the foregoing solution is prescribed as an inner boundary condition at  $r_2$ , while a convection condition is prescribed at the outer surface ( $r_3$ ). For  $1 \times 10^8 \leq \dot{q} \leq 5 \times 10^8\text{ W}/\text{m}^3$ , the following distributions are obtained.

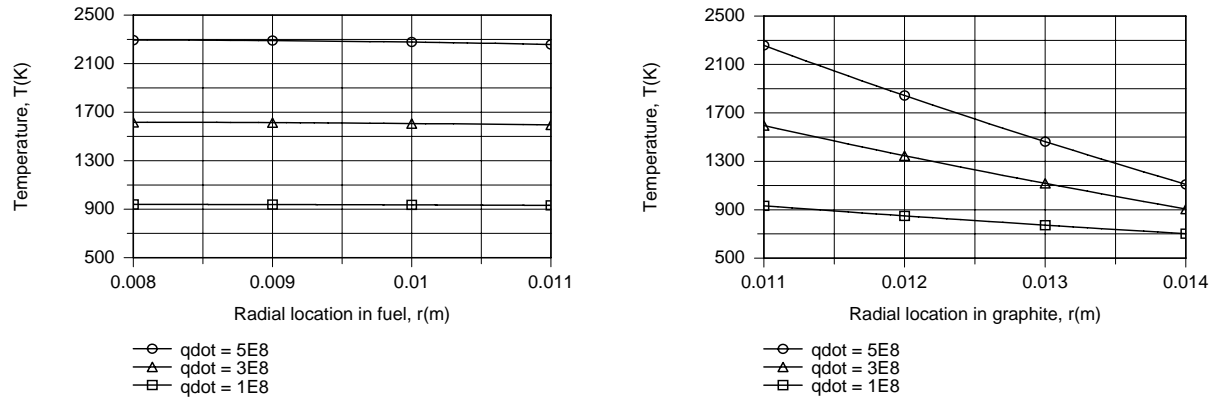

The comparatively large value of  $k_t$  yields small temperature variations across the fuel element, while the small value of  $k_g$  results in large temperature variations across the graphite. Operation at  $\dot{q} = 5 \times 10^8\text{ W}/\text{m}^3$  is clearly unacceptable, since the melting points of thorium and graphite are exceeded and approached, respectively. To prevent softening of the materials, which would occur below their melting points, the reactor should not be operated much above  $\dot{q} = 3 \times 10^8\text{ W}/\text{m}^3$ .

**COMMENTS:** A contact resistance at the thorium/graphite interface would increase temperatures in the fuel element, thereby reducing the maximum allowable value of  $\dot{q}$ .

### PROBLEM 3.101

**KNOWN:** Long rod experiencing uniform volumetric generation encapsulated by a circular sleeve exposed to convection.

**FIND:** (a) Temperature at the interface between rod and sleeve and on the outer surface, (b) Temperature at center of rod.

**SCHEMATIC:**

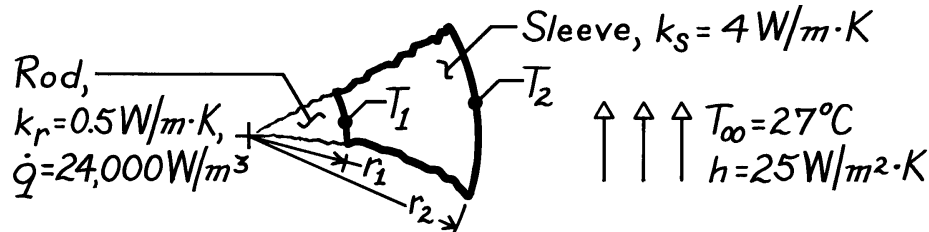

**ASSUMPTIONS:** (1) One-dimensional radial conduction in rod and sleeve, (2) Steady-state conditions, (3) Uniform volumetric generation in rod, (4) Negligible contact resistance between rod and sleeve.

**ANALYSIS:** (a) Construct a thermal circuit for the sleeve,

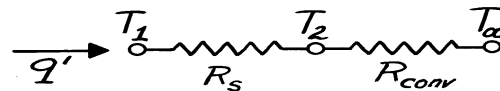

where

$$q' = \dot{E}'_{\text{gen}} = \dot{q} \pi D_1^2 / 4 = 24,000 \text{ W/m}^3 \times \pi \times (0.20 \text{ m})^2 / 4 = 754.0 \text{ W/m}$$

$$R'_s = \frac{\ln(r_2/r_1)}{2\pi k_s} = \frac{\ln(400/200)}{2\pi \times 4 \text{ W/m}\cdot\text{K}} = 2.758 \times 10^{-2} \text{ m}\cdot\text{K/W}$$

$$R'_{\text{conv}} = \frac{1}{h\pi D_2} = \frac{1}{25 \text{ W/m}^2\cdot\text{K} \times \pi \times 0.400 \text{ m}} = 3.183 \times 10^{-2} \text{ m}\cdot\text{K/W}$$

The rate equation can be written as

$$q' = \frac{T_1 - T_\infty}{R'_s + R'_{\text{conv}}} = \frac{T_2 - T_\infty}{R'_{\text{conv}}}$$

$$T_1 = T_\infty + q'(R'_s + R'_{\text{conv}}) = 27^\circ\text{C} + 754 \text{ W/m} \left( 2.758 \times 10^{-2} + 3.183 \times 10^{-2} \right) \text{ K/W}\cdot\text{m} = 71.8^\circ\text{C} \quad <$$

$$T_2 = T_\infty + q'R'_{\text{conv}} = 27^\circ\text{C} + 754 \text{ W/m} \times 3.183 \times 10^{-2} \text{ m}\cdot\text{K/W} = 51.0^\circ\text{C}. \quad <$$

(b) The temperature at the center of the rod is

$$T(0) = T_0 = \frac{\dot{q}r_1^2}{4k_r} + T_1 = \frac{24,000 \text{ W/m}^3 (0.100 \text{ m})^2}{4 \times 0.5 \text{ W/m}\cdot\text{K}} + 71.8^\circ\text{C} = 192^\circ\text{C}. \quad <$$

**COMMENTS:** The thermal resistances due to conduction in the sleeve and convection are comparable. Will increasing the sleeve outer diameter cause the surface temperature  $T_2$  to increase or decrease?

### PROBLEM 3.102

**KNOWN:** Radius, thermal conductivity, heat generation and convection conditions associated with a solid sphere.

**FIND:** Temperature distribution.

**SCHEMATIC:**

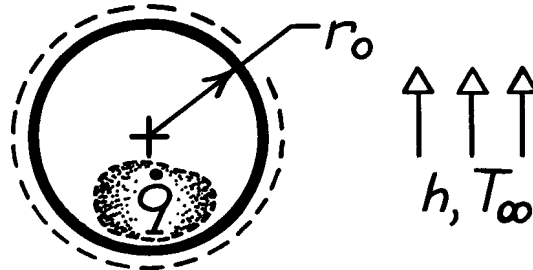

**ASSUMPTIONS:** (1) Steady-state conditions, (2) One-dimensional radial conduction, (3) Constant properties, (4) Uniform heat generation.

**ANALYSIS:** Integrating the appropriate form of the heat diffusion equation,

$$\frac{1}{r^2} \frac{d}{dr} \left[ kr^2 \frac{dT}{dr} \right] + \dot{q} = 0 \quad \text{or} \quad \frac{d}{dr} \left[ r^2 \frac{dT}{dr} \right] = -\frac{\dot{q}r^2}{k}$$

$$r^2 \frac{dT}{dr} = -\frac{\dot{q}r^3}{3k} + C_1 \quad \frac{dT}{dr} = -\frac{\dot{q}r}{3k} + \frac{C_1}{r^2}$$

$$T(r) = -\frac{\dot{q}r^2}{6k} - \frac{C_1}{r} + C_2.$$

The boundary conditions are:  $\left. \frac{dT}{dr} \right|_{r=0} = 0$  hence  $C_1 = 0$ , and

$$\left. -k \frac{dT}{dr} \right|_{r=r_0} = h [T(r_0) - T_\infty].$$

Substituting into the second boundary condition ( $r = r_0$ ), find

$$\frac{\dot{q}r_0}{3} = h \left[ -\frac{\dot{q}r_0^2}{6k} + C_2 - T_\infty \right] \quad C_2 = \frac{\dot{q}r_0}{3h} + \frac{\dot{q}r_0^2}{6k} + T_\infty.$$

The temperature distribution has the form

$$T(r) = \frac{\dot{q}}{6k} (r_0^2 - r^2) + \frac{\dot{q}r_0}{3h} + T_\infty.$$

**COMMENTS:** To verify the above result, obtain  $T(r_0) = T_s$ ,

$$T_s = \frac{\dot{q}r_0}{3h} + T_\infty$$

Applying energy balance to the control volume about the sphere,

$$\dot{q} \left[ \frac{4}{3} \pi r_0^3 \right] = h 4\pi r_0^2 (T_s - T_\infty) \quad \text{find} \quad T_s = \frac{\dot{q}r_0}{3h} + T_\infty.$$

### PROBLEM 3.103

**KNOWN:** Radial distribution of heat dissipation of a spherical container of radioactive wastes. Surface convection conditions.

**FIND:** Radial temperature distribution.

**SCHEMATIC:** \_\_\_\_\_

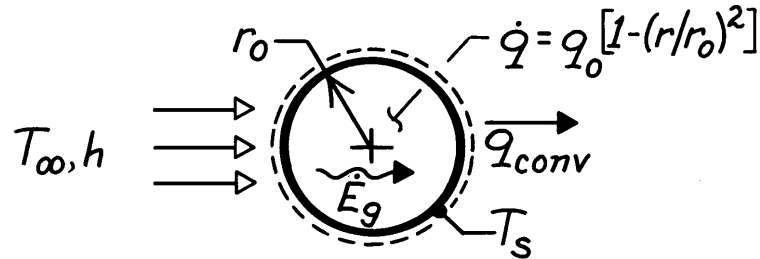

**ASSUMPTIONS:** (1) Steady-state conditions, (2) One-dimensional conduction, (3) Constant properties, (4) Negligible temperature drop across container wall.

**ANALYSIS:** The appropriate form of the heat equation is

$$\frac{1}{r^2} \frac{d}{dr} \left( r^2 \frac{dT}{dr} \right) = -\frac{\dot{q}}{k} = -\frac{\dot{q}_0}{k} \left[ 1 - \left( \frac{r}{r_0} \right)^2 \right].$$

Hence 
$$r^2 \frac{dT}{dr} = -\frac{\dot{q}_0}{k} \left( \frac{r^3}{3} - \frac{r^5}{5r_0^2} \right) + C_1$$

$$T = -\frac{\dot{q}_0}{k} \left( \frac{r^2}{6} - \frac{r^4}{20r_0^2} \right) - \frac{C_1}{r} + C_2.$$

From the boundary conditions,

$$dT/dr|_{r=0} = 0 \quad \text{and} \quad -kdT/dr|_{r=r_0} = h[T(r_0) - T_{\infty}]$$

it follows that  $C_1 = 0$  and

$$\dot{q}_0 \left( \frac{r_0}{3} - \frac{r_0}{5} \right) = h \left[ -\frac{\dot{q}_0}{k} \left( \frac{r_0^2}{6} - \frac{r_0^2}{20} \right) + C_2 - T_{\infty} \right]$$

$$C_2 = \frac{2r_0\dot{q}_0}{15h} + \frac{7\dot{q}_0r_0^2}{60k} + T_{\infty}.$$

Hence 
$$T(r) = T_{\infty} + \frac{2r_0\dot{q}_0}{15h} + \frac{\dot{q}_0r_0^2}{k} \left[ \frac{7}{60} - \frac{1}{6} \left( \frac{r}{r_0} \right)^2 + \frac{1}{20} \left( \frac{r}{r_0} \right)^4 \right].$$

**COMMENTS:** Applying the above result at  $r_0$  yields

$$T_s = T(r_0) = T_{\infty} + (2r_0\dot{q}_0/15h).$$

The same result may be obtained by applying an energy balance to a control surface about the container, where  $\dot{E}_g = q_{conv}$ . The maximum temperature exists at  $r = 0$ .

### PROBLEM 3.104

**KNOWN:** Dimensions and thermal conductivity of a spherical container. Thermal conductivity and volumetric energy generation within the container. Outer convection conditions.

**FIND:** (a) Outer surface temperature, (b) Container inner surface temperature, (c) Temperature distribution within and center temperature of the wastes, (d) Feasibility of operating at twice the energy generation rate.

**SCHEMATIC:**

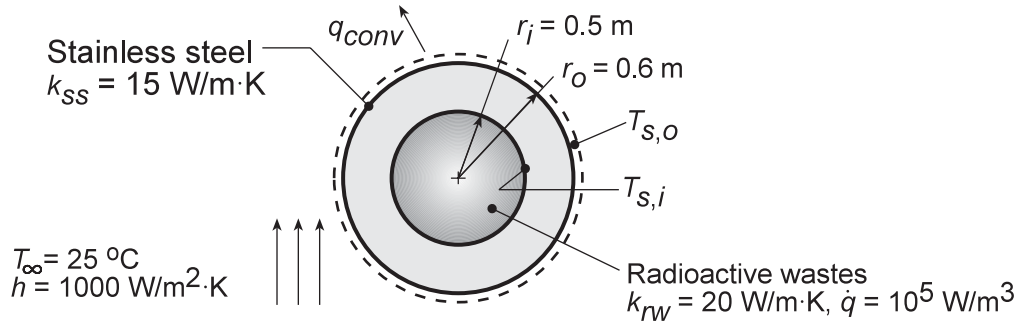

**ASSUMPTIONS:** (1) Steady-state conditions, (2) Constant properties, (3) One-dimensional radial conduction.

**ANALYSIS:** (a) For a control volume which includes the container, conservation of energy yields  $\dot{E}_g - \dot{E}_{out} = 0$ , or  $\dot{q}V - q_{conv} = 0$ . Hence

$$\dot{q} \left( \frac{4}{3} \right) (\pi r_i^3) = h 4\pi r_o^2 (T_{s,o} - T_\infty)$$

and with  $\dot{q} = 10^5 \text{ W/m}^3$ ,

$$T_{s,o} = T_\infty + \frac{\dot{q} r_i^3}{3hr_o^2} = 25^\circ\text{C} + \frac{10^5 \text{ W/m}^3 (0.5 \text{ m})^3}{3000 \text{ W/m}^2 \cdot \text{K} (0.6 \text{ m})^2} = 36.6^\circ\text{C}.$$

(b) Performing a surface energy balance at the outer surface,  $\dot{E}_{in} - \dot{E}_{out} = 0$  or  $q_{cond} - q_{conv} = 0$ .

Hence

$$\frac{4\pi k_{ss} (T_{s,i} - T_{s,o})}{(1/r_i) - (1/r_o)} = h 4\pi r_o^2 (T_{s,o} - T_\infty)$$

$$T_{s,i} = T_{s,o} + \frac{h}{k_{ss}} \left( \frac{r_o}{r_i} - 1 \right) r_o (T_{s,o} - T_\infty) = 36.6^\circ\text{C} + \frac{1000 \text{ W/m}^2 \cdot \text{K}}{15 \text{ W/m} \cdot \text{K}} (0.2) 0.6 \text{ m} (11.6^\circ\text{C}) = 129.4^\circ\text{C}.$$

(c) The heat equation in spherical coordinates is

$$k_{rw} \frac{d}{dr} \left( r^2 \frac{dT}{dr} \right) + \dot{q} r^2 = 0.$$

Solving,

$$r^2 \frac{dT}{dr} = -\frac{\dot{q} r^3}{3k_{rw}} + C_1 \quad \text{and} \quad T(r) = -\frac{\dot{q} r^2}{6k_{rw}} - \frac{C_1}{r} + C_2$$

Applying the boundary conditions,

$$\left. \frac{dT}{dr} \right|_{r=0} = 0 \quad \text{and} \quad T(r_i) = T_{s,i}$$

$$C_1 = 0 \quad \text{and} \quad C_2 = T_{s,i} + \dot{q} r_i^2 / 6k_{rw}.$$

Continued...



### PROBLEM 3.104 (Cont.)

Hence

$$T(r) = T_{s,i} + \frac{\dot{q}}{6k_{rw}} (r_i^2 - r^2) \quad \angle$$

At  $r = 0$ ,

$$T(0) = T_{s,i} + \frac{\dot{q}r_i^2}{6k_{rw}} = 129.4^\circ\text{C} + \frac{10^5 \text{ W/m}^3 (0.5 \text{ m})^2}{6(20 \text{ W/m}\cdot\text{K})} = 337.7^\circ\text{C} \quad \angle$$

(d) The feasibility assessment may be performed by using the IHT model for one-dimensional, steady-state conduction in a solid sphere, with the surface boundary condition prescribed in terms of the total thermal resistance

$$R''_{\text{tot},i} = (4\pi r_i^2) R_{\text{tot}} = R''_{\text{cnd},i} + R''_{\text{cnv},i} = \frac{r_i^2 \left[ (1/r_i) - (1/r_o) \right]}{k_{ss}} + \frac{1}{h} \left( \frac{r_i}{r_o} \right)^2$$

where, for  $r_o = 0.6 \text{ m}$  and  $h = 1000 \text{ W/m}^2\cdot\text{K}$ ,  $R''_{\text{cnd},i} = 5.56 \times 10^{-3} \text{ m}^2\cdot\text{K/W}$ ,  $R''_{\text{cnv},i} = 6.94 \times 10^{-4} \text{ m}^2\cdot\text{K/W}$ , and  $R''_{\text{tot},i} = 6.25 \times 10^{-3} \text{ m}^2\cdot\text{K/W}$ . Results for the center temperature are shown below.

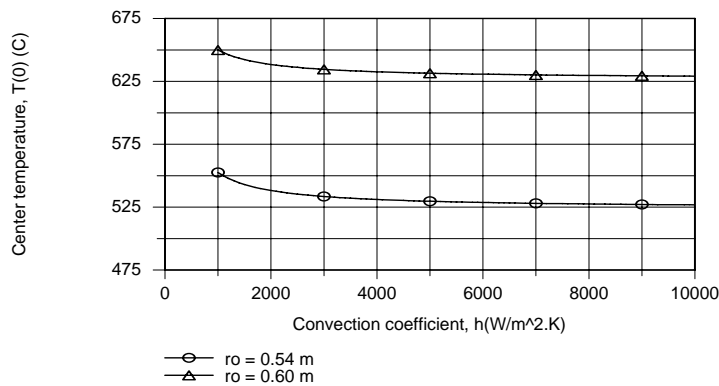

Clearly, even with  $r_o = 0.54 \text{ m} = r_{o,\text{min}}$  and  $h = 10,000 \text{ W/m}^2\cdot\text{K}$  (a practical upper limit),  $T(0) > 475^\circ\text{C}$  and the desired condition can not be met. The corresponding resistances are  $R''_{\text{cnd},i} = 2.47 \times 10^{-3} \text{ m}^2\cdot\text{K/W}$ ,  $R''_{\text{cnv},i} = 8.57 \times 10^{-5} \text{ m}^2\cdot\text{K/W}$ , and  $R''_{\text{tot},i} = 2.56 \times 10^{-3} \text{ m}^2\cdot\text{K/W}$ . The conduction resistance remains dominant, and the effect of reducing  $R''_{\text{cnv},i}$  by increasing  $h$  is small. *The proposed extension is not feasible.*

**COMMENTS:** A value of  $\dot{q} = 1.79 \times 10^5 \text{ W/m}^3$  would allow for operation at  $T(0) = 475^\circ\text{C}$  with  $r_o = 0.54 \text{ m}$  and  $h = 10,000 \text{ W/m}^2\cdot\text{K}$ .

### PROBLEM 3.105

**KNOWN:** Carton of apples, modeled as 80-mm diameter spheres, ventilated with air at 5°C and experiencing internal volumetric heat generation at a rate of 4000 J/kg·day.

**FIND:** (a) The apple center and surface temperatures when the convection coefficient is 7.5 W/m<sup>2</sup>·K, and (b) Compute and plot the apple temperatures as a function of air velocity,  $V$ , for the range  $0.1 \leq V \leq 1$  m/s, when the convection coefficient has the form  $h = C_1 V^{0.425}$ , where  $C_1 = 10.1$  W/m<sup>2</sup>·K·(m/s)<sup>0.425</sup>.

**SCHEMATIC:**

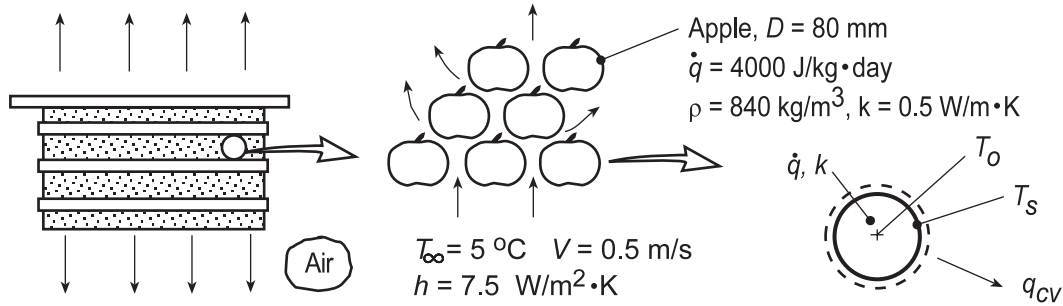

**ASSUMPTIONS:** (1) Apples can be modeled as spheres, (2) Each apple experiences flow of ventilation air at  $T_\infty = 5^\circ\text{C}$ , (3) One-dimensional radial conduction, (4) Constant properties and (5) Uniform heat generation.

**ANALYSIS:** (a) From Eq. C.24, the temperature distribution in a solid sphere (apple) with uniform generation is

$$T(r) = \frac{\dot{q}r_o^2}{6k} \left( 1 - \frac{r^2}{r_o^2} \right) + T_s \quad (1)$$

To determine  $T_s$ , perform an energy balance on the apple as shown in the sketch above, with volume  $V = 4/3\pi r_o^3$ ,

$$\begin{aligned} \dot{E}_{\text{in}} - \dot{E}_{\text{out}} + \dot{E}_g &= 0 & -q_{\text{cv}} + \dot{q}V &= 0 \\ -h(4\pi r_o^2)(T_s - T_\infty) + \dot{q}(4\pi r_o^3/3) &= 0 & & (2) \\ -7.5 \text{ W/m}^2 \cdot \text{K} (4\pi \times 0.040^2 \text{ m}^2)(T_s - 5^\circ\text{C}) + 38.9 \text{ W/m}^3 (4\pi \times 0.040^3 \text{ m}^3/3) &= 0 \end{aligned}$$

where the volumetric generation rate is

$$\dot{q} = 4000 \text{ J/kg} \cdot \text{day}$$

$$\dot{q} = 4000 \text{ J/kg} \cdot \text{day} \times 840 \text{ kg/m}^3 \times (1 \text{ day}/24 \text{ hr}) \times (1 \text{ hr}/3600 \text{ s})$$

$$\dot{q} = 38.9 \text{ W/m}^3$$

and solving for  $T_s$ , find

$$T_s = 5.14^\circ\text{C} \quad <$$

From Eq. (1), at  $r = 0$ , with  $T_s$ , find

$$T(0) = \frac{38.9 \text{ W/m}^3 \times 0.040^2 \text{ m}^2}{6 \times 0.5 \text{ W/m} \cdot \text{K}} + 5.14^\circ\text{C} = 0.12^\circ\text{C} + 5.14^\circ\text{C} = 5.26^\circ\text{C} \quad <$$

Continued...

### PROBLEM 3.105 (Cont.)

(b) With the convection coefficient depending upon velocity,

$$h = C_1 V^{0.425}$$

with  $C_1 = 10.1 \text{ W/m}^2 \cdot \text{K} \cdot (\text{m/s})^{0.425}$ , and using the energy balance of Eq. (2), calculate and plot  $T_s$  as a function of ventilation air velocity  $V$ . With very low velocities, the center temperature is nearly  $0.5^\circ\text{C}$  higher than the air. From our earlier calculation we know that  $T(0) - T_s = 0.12^\circ\text{C}$  and is independent of  $V$ .

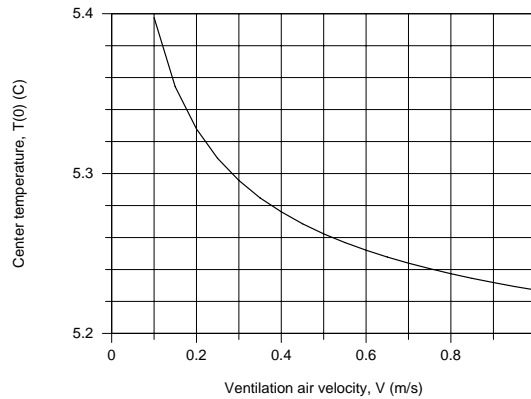

**COMMENTS:** (1) While the temperature within the apple is nearly isothermal, the center temperature will track the ventilation air temperature which will increase as it passes through stacks of cartons.

(2) The *IHT* Workspace used to determine  $T_s$  for the base condition and generate the above plot is shown below.

**// The temperature distribution, Eq (1),**

$$T_r = \dot{q} \cdot r^2 / (4 \cdot k) \cdot (1 - r^2/r_0^2) + T_s$$

**// Energy balance on the apple, Eq (2)**

$$-q_{cv} + \dot{q} \cdot \text{Vol} = 0$$

$$\text{Vol} = 4/3 \cdot \pi \cdot r_0^3$$

**// Convection rate equation:**

$$q_{cv} = h \cdot A_s \cdot (T_s - T_{\infty})$$

$$A_s = 4 \cdot \pi \cdot r_0^2$$

**// Generation rate:**

$$\dot{q} = \dot{q}_{\text{dotm}} \cdot (1/24) \cdot (1/3600) \cdot \rho$$

// Generation rate,  $\text{W/m}^3$ ; Conversions: days/h and h/sec

**// Assigned variables:**

$$r_0 = 0.080$$

// Radius of apple, m

$$k = 0.5$$

// Thermal conductivity,  $\text{W/m} \cdot \text{K}$

$$\dot{q}_{\text{dotm}} = 4000$$

// Generation rate,  $\text{J/kg} \cdot \text{K}$

$$\rho = 840$$

// Specific heat,  $\text{J/kg} \cdot \text{K}$

$$r = 0$$

// Center, m; location for  $T(0)$

$$h = 7.5$$

// Convection coefficient,  $\text{W/m}^2 \cdot \text{K}$ ; base case,  $V = 0.5 \text{ m/s}$

$$// h = C_1 \cdot V^{0.425}$$

// Correlation

$$// C_1 = 10.1$$

$$// V = 0.5$$

// Air velocity, m/s; range 0.1 to 1 m/s

$$T_{\infty} = 5$$

// Air temperature, C

### PROBLEM 3.106

**KNOWN:** Plane wall, long cylinder and sphere, each with characteristic length  $a$ , thermal conductivity  $k$  and uniform volumetric energy generation rate  $\dot{q}$ .

**FIND:** (a) On the same graph, plot the dimensionless temperature,  $[T(x \text{ or } r) - T(a)] / [\dot{q} a^2 / 2k]$ , vs. the dimensionless characteristic length,  $x/a$  or  $r/a$ , for each shape; (b) Which shape has the smallest temperature difference between the center and the surface? Explain this behavior by comparing the ratio of the volume-to-surface area; and (c) Which shape would be preferred for use as a nuclear fuel element? Explain why?

**SCHEMATIC:**

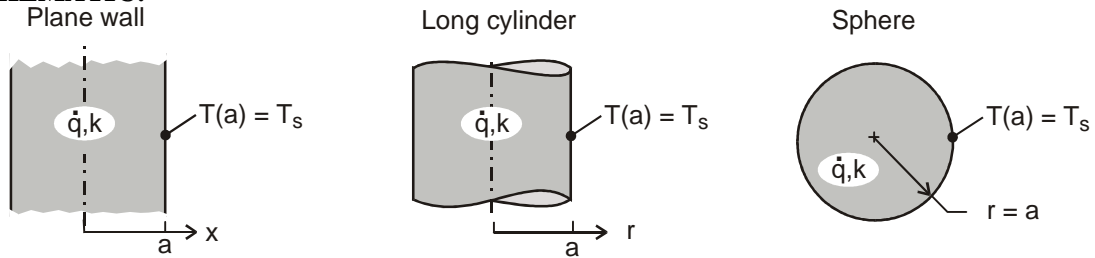

**ASSUMPTIONS:** (1) Steady-state conditions, (2) One-dimensional conduction, (3) Constant properties and (4) Uniform volumetric generation.

**ANALYSIS:** (a) For each of the shapes, with  $T(a) = T_s$ , the dimensionless temperature distributions can be written by inspection from results in Appendix C.3.

Plane wall, Eq. C.22

$$\frac{T(x) - T_s}{\dot{q} a^2 / 2k} = 1 - \left(\frac{x}{a}\right)^2$$

Long cylinder, Eq. C.23

$$\frac{T(r) - T_s}{\dot{q} a^2 / 2k} = \frac{1}{2} \left[ 1 - \left(\frac{r}{a}\right)^2 \right]$$

Sphere, Eq. C.24

$$\frac{T(r) - T_s}{\dot{q} a^2 / 2k} = \frac{1}{3} \left[ 1 - \left(\frac{r}{a}\right)^2 \right]$$

The dimensionless temperature distributions using the foregoing expressions are shown in the graph below.

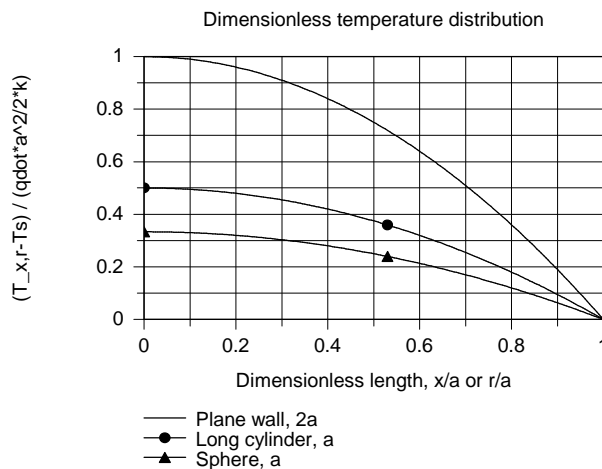

Continued ...

**PROBLEM 3.106 (Cont.)**

(b) The sphere shape has the smallest temperature difference between the center and surface,  $T(0) - T(a)$ . The ratio of volume-to-surface-area,  $\forall/A_s$ , for each of the shapes is

$$\text{Plane wall} \quad \frac{\forall}{A_s} = \frac{a(1 \times 1)}{(1 \times 1)} = a$$

$$\text{Long cylinder} \quad \frac{\forall}{A_s} = \frac{\pi a^2 \times 1}{2\pi a \times 1} = \frac{a}{2}$$

$$\text{Sphere} \quad \frac{\forall}{A_s} = \frac{4\pi a^3 / 3}{4\pi a^2} = \frac{a}{3}$$

The smaller the  $\forall/A_s$  ratio, the smaller the temperature difference,  $T(0) - T(a)$ .

(c) The sphere would be the preferred element shape since, for a given  $\forall/A_s$  ratio, which controls the generation and transfer rates, the sphere will operate at the lowest temperature.

### PROBLEM 3.107

**KNOWN:** Radius, thickness, and incident flux for a radiation heat gauge.

**FIND:** Expression relating incident flux to temperature difference between center and edge of gauge.

**SCHEMATIC:**

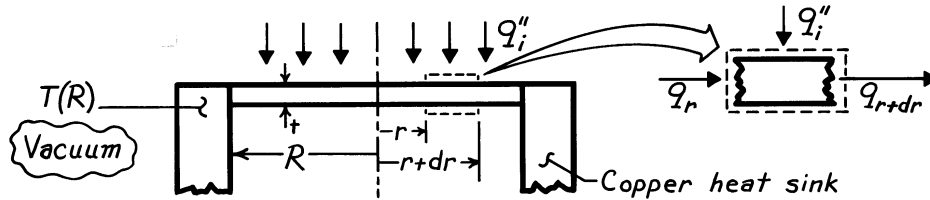

**ASSUMPTIONS:** (1) Steady-state conditions, (2) One-dimensional conduction in  $r$  (negligible temperature drop across foil thickness), (3) Constant properties, (4) Uniform incident flux, (5) Negligible heat loss from foil due to radiation exchange with enclosure wall, (6) Negligible contact resistance between foil and heat sink.

**ANALYSIS:** Applying energy conservation to a circular ring extending from  $r$  to  $r + dr$ ,

$$q_r + q_i''(2\pi r dr) = q_{r+dr}, \quad q_r = -k(2\pi r t) \frac{dT}{dr}, \quad q_{r+dr} = q_r + \frac{dq_r}{dr} dr.$$

Rearranging, find that

$$q_i''(2\pi r dr) = \frac{d}{dr} \left[ (-k2\pi r t) \frac{dT}{dr} \right] dr$$

$$\frac{d}{dr} \left[ r \frac{dT}{dr} \right] = -\frac{q_i''}{kt} r.$$

Integrating,

$$r \frac{dT}{dr} = -\frac{q_i'' r^2}{2kt} + C_1 \quad \text{and} \quad T(r) = -\frac{q_i'' r^2}{4kt} + C_1 \ln r + C_2.$$

With  $dT/dr|_{r=0} = 0$ ,  $C_1 = 0$  and with  $T(r = R) = T(R)$ ,

$$T(R) = -\frac{q_i'' R^2}{4kt} + C_2 \quad \text{or} \quad C_2 = T(R) + \frac{q_i'' R^2}{4kt}.$$

Hence, the temperature distribution is

$$T(r) = \frac{q_i''}{4kt} (R^2 - r^2) + T(R).$$

Applying this result at  $r = 0$ , it follows that

$$q_i'' = \frac{4kt}{R^2} [T(0) - T(R)] = \frac{4kt}{R^2} \Delta T.$$

<

**COMMENTS:** This technique allows for determination of a radiation flux from measurement of a temperature difference. It becomes inaccurate if emission from the foil becomes significant.

### PROBLEM 3.108

**KNOWN:** Net radiative flux to absorber plate.

**FIND:** (a) Maximum absorber plate temperature, (b) Rate of energy collected per tube.

**SCHEMATIC:**

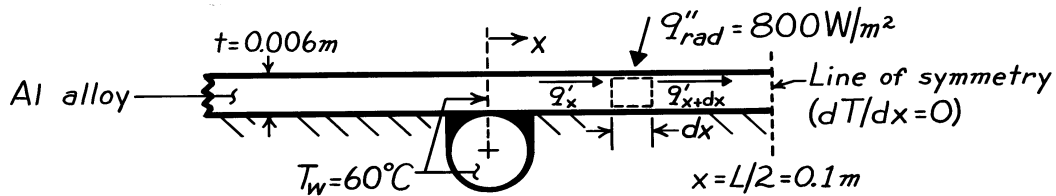

**ASSUMPTIONS:** (1) Steady-state conditions, (2) One-dimensional ( $x$ ) conduction along absorber plate, (3) Uniform radiation absorption at plate surface, (4) Negligible losses by conduction through insulation, (5) Negligible losses by convection at absorber plate surface, (6) Temperature of absorber plate at  $x = 0$  is approximately that of the water.

**PROPERTIES:** Table A-1, Aluminum alloy (2024-T6):  $k \approx 180 \text{ W/m}\cdot\text{K}$ .

**ANALYSIS:** The absorber plate acts as an extended surface (a conduction-radiation system), and a differential equation which governs its temperature distribution may be obtained by applying Eq. 1.11b to a differential control volume. For a unit length of tube

$$q'_x + q''_{\text{rad}}(dx) - q'_{x+dx} = 0.$$

With 
$$q'_{x+dx} = q'_x + \frac{dq'_x}{dx} dx$$

and 
$$q'_x = -kt \frac{dT}{dx}$$

it follows that,

$$q''_{\text{rad}} - \frac{d}{dx} \left[ -kt \frac{dT}{dx} \right] = 0$$

$$\frac{d^2T}{dx^2} + \frac{q''_{\text{rad}}}{kt} = 0$$

Integrating twice it follows that, the general solution for the temperature distribution has the form,

$$T(x) = -\frac{q''_{\text{rad}}}{2kt} x^2 + C_1 x + C_2.$$

Continued ...

**PROBLEM 3.108 (Cont.)**

The boundary conditions are:

$$T(0) = T_w \quad C_2 = T_w$$

$$\left. \frac{dT}{dx} \right]_{x=L/2} = 0 \quad C_1 = \frac{q''_{\text{rad}} L}{2kt}$$

Hence,

$$T(x) = \frac{q''_{\text{rad}}}{2kt} x(L-x) + T_w.$$

The maximum absorber plate temperature, which is at  $x = L/2$ , is therefore

$$T_{\text{max}} = T(L/2) = \frac{q''_{\text{rad}} L^2}{8kt} + T_w.$$

The rate of energy collection per tube may be obtained by applying Fourier's law at  $x = 0$ . That is, energy is transferred to the tubes via conduction through the absorber plate. Hence,

$$q' = 2 \left[ -k t \left. \frac{dT}{dx} \right]_{x=0} \right]$$

where the factor of two arises due to heat transfer from both sides of the tube. Hence,

$$q' = -Lq''_{\text{rad}}.$$

Hence

$$T_{\text{max}} = \frac{800 \frac{\text{W}}{\text{m}^2} (0.2\text{m})^2}{8 \left[ 180 \frac{\text{W}}{\text{m} \cdot \text{K}} \right] (0.006\text{m})} + 60^\circ \text{C}$$

or  $T_{\text{max}} = 63.7^\circ \text{C}$  <

and  $q' = -0.2\text{m} \times 800 \text{ W/m}^2$

or  $q' = -160 \text{ W/m}$ . <

**COMMENTS:** Convection losses in the typical flat plate collector, which is not evacuated, would reduce the value of  $q'$ .



### PROBLEM 3.109

**KNOWN:** Diameter and base temperature of a silicon carbide nanowire, required temperature of the catalyst tip.

**FIND:** Maximum length of a nanowire that may be grown under specified conditions.

**SCHEMATIC:**

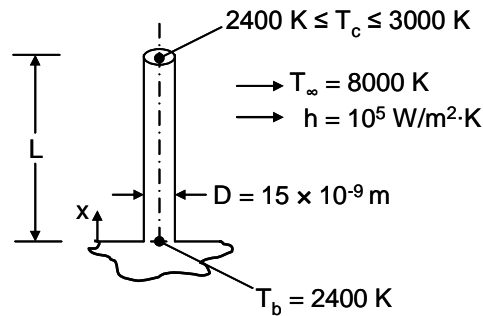

**ASSUMPTIONS:** (1) Nanowire stops growing when  $T_c = T(x = L) = 3000$  K, (2) Constant properties, (3) One-dimensional heat transfer, (4) Convection from the tip of the nanowire, (5) Nanowire grows very slowly, (6) Negligible impact of nanoscale heat transfer effects.

**PROPERTIES:** Table A.2, silicon carbide (1500 K):  $k = 30$  W/m.K.

**ANALYSIS:** The tip of the nanowire is initially at  $T = 2400$  K, and increases in temperature as the nanowire becomes longer. At steady-state, the tip reaches  $T = 3000$  K. The temperature distribution at steady-state is given by Eq. 3.75:

$$\frac{\theta}{\theta_b} = \frac{\cosh m(L - x) + (h/mk) \sinh m(L - x)}{\cosh mL + (h/mk) \sinh mL} \quad (1)$$

where

$$m = \left( \frac{hP}{kA_c} \right)^{1/2} = \left( \frac{4h}{kD} \right)^{1/2} = \left( \frac{4 \times 10^5 \text{ W/m}^2 \cdot \text{K}}{30 \text{ W/m} \cdot \text{K} \times 15 \times 10^{-9} \text{ m}} \right)^{1/2} = 943 \times 10^3 \text{ m}^{-1}$$

and

$$\frac{h}{mk} = \frac{10^5 \text{ W/m}^2 \cdot \text{K}}{943 \times 10^3 \text{ m}^{-1} \times 30 \text{ W/m} \cdot \text{K}} = 3.53 \times 10^{-3}$$

Equation 1, evaluated at  $x = L$ , is

$$\frac{\theta}{\theta_b} = \frac{(3000 - 8000) \text{ K}}{(2400 - 8000) \text{ K}} = 0.893 = \frac{1}{\cosh(943 \times 10^3 \times L) + 3.53 \times 10^{-3} \sinh(943 \times 10^3 \times L)}$$

A trial-and-error solution yields  $L = 510 \times 10^{-9} \text{ m} = 510 \text{ nm}$

<

Continued...

### PROBLEM 3.109 (Cont.)

**COMMENTS:** (1) The importance of radiation heat transfer may be ascertained by evaluating Eq. 1.9. Assuming large surroundings at a temperature of  $T_{\text{sur}} = 8000 \text{ K}$  and an emissivity of unity, the radiation heat transfer coefficient at the fin tip is

$$\begin{aligned} h_r &= \varepsilon\sigma(T(x=L) + T_{\text{sur}})\left[T^2(x=L) + T_{\text{sur}}^2\right] \\ &= 5.67 \times 10^{-8} \text{ W/m}^2 \cdot \text{K}^4 \times (3000 \text{ K} + 8000 \text{ K}) \times \left[(3000 \text{ K})^2 + (8000 \text{ K})^2\right] = 4.5 \times 10^4 \text{ W/m}^2 \cdot \text{K} \end{aligned}$$

We see that  $h_r < h$ , but radiation may be important. (2) The thermal conductivity has been evaluated at 1500 K and extrapolated to a much higher temperature. More accurate values of the thermal conductivity, accounting for the high temperature and possible nanoscale heat transfer effects, are desirable. (3) If the nanowire were to grow rapidly, the transient temperature distribution within the nanowire would need to be evaluated.

### PROBLEM 3.110

**KNOWN:** Process for growing thin, photovoltaic grade silicon sheets. Sheet dimensions, ambient temperature and heat transfer coefficient.

**FIND:** The velocity at which the silicon sheet can be extracted from the pool of molten silicon.

**SCHEMATIC:**

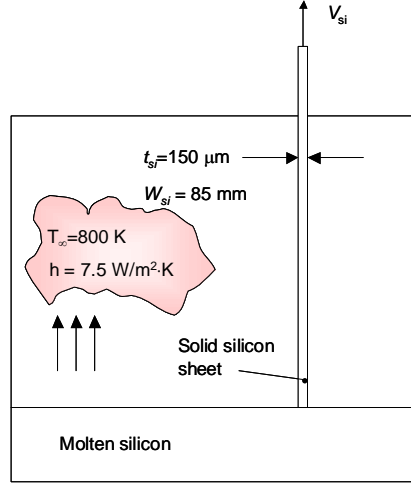

**ASSUMPTIONS:** (1) Steady-state, one-dimensional conditions, (2) Negligible radiation heat transfer, (3) Silicon sheet behaves as an infinite fin, (4) Constant properties, (5) Neglect advection inside the silicon sheet, (6) Neglect the presence of the strings, (7) Molten silicon is isothermal at the melting point (1685 K).

**PROPERTIES:** Table A-1, Silicon ( $\bar{T} = (1685 \text{ K} + 800 \text{ K})/2 = 1243 \text{ K}$ ):  $k = 25.3 \text{ W/m}\cdot\text{K}$ ,  $\rho = 2330 \text{ kg/m}^3$ ,  $h_{sl} = 1.8 \times 10^6 \text{ J/kg}$  (given).

**ANALYSIS:** The velocity is expected to be very small. Therefore, heat transfer *within* the silicon sheet may be considered to be by conduction only. In addition, thermal energy is generated due to solidification at the solid-liquid interface, and must be removed by conduction along the silicon sheet. Therefore,

$$\dot{m}h_{sl} = \rho W_{si} t_{si} V_{si} h_{sl} = q_{\text{cond}} \quad (1)$$

From Table 3.4 for an infinite fin

$$q_{\text{cond}} = q_f = M = \sqrt{hPkA_c} \theta_b = \sqrt{h2(W_{si} + t_{si})kW_{si}t_{si}} (T_f - T_\infty) \quad (2)$$

Combining Equations (1) and (2) yields

$$V_{si} = \frac{\sqrt{2h(W_{si} + t_{si})kW_{si}t_{si}} (T_f - T_\infty)}{\rho W_{si} t_{si} h_{sl}}$$

$$= \frac{\sqrt{2 \times 7.5 \text{ W/m}^2 \cdot \text{K} \times (0.085 \text{ m} + 150 \times 10^{-6} \text{ m}) \times 25.3 \text{ W/m} \cdot \text{K} \times 0.085 \text{ m} \times 150 \times 10^{-6} \text{ m}}}{2330 \text{ kg/m}^3 \times 0.085 \text{ m} \times 150 \times 10^{-6} \text{ m} \times 1.8 \times 10^6 \text{ J/kg}} (1685 \text{ K} - 800 \text{ K})$$

$$= 335 \times 10^{-6} \text{ m/s} \times 1000 \text{ mm/m} \times 60 \text{ s/min} = 20.1 \text{ mm/min}$$

<  
Continued...

### **PROBLEM 3.110 (Cont.)**

**COMMENTS:** (1) The rate at which the photovoltaic sheet can be manufactured is limited by heat transfer effects. If the velocity were increased above the value calculated, the solid sheet would be lifted out of the molten pool of silicon, and the manufacturing process would stop. If the velocity were below the value calculated, the solid-liquid interface would begin to propagate downward into the pool, increasing the thickness of the silicon sheet. (2) As the thickness of the photovoltaic sheet is reduced, less silicon is needed to fabricate a solar panel, reducing manufacturing costs, reducing energy consumption in the manufacturing process, and conserving natural resources. Equally important, as the thickness of the sheet is reduced, the velocity at which the sheet can be pulled from the pool of molten silicon can be increased, resulting in production of more photovoltaic surface area per unit time.

### PROBLEM 3.111

**KNOWN:** Surface conditions and thickness of a solar collector absorber plate. Temperature of working fluid.

**FIND:** (a) Differential equation which governs plate temperature distribution, (b) Form of the temperature distribution.

**SCHEMATIC:**

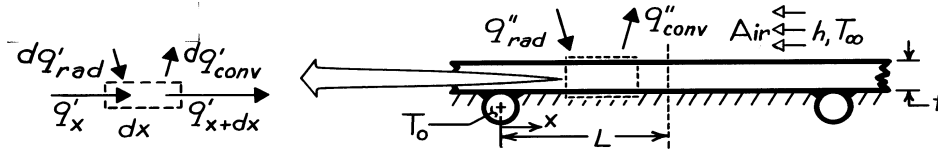

**ASSUMPTIONS:** (1) Steady-state conditions, (2) One-dimensional conduction, (3) Adiabatic bottom surface, (4) Uniform radiation flux and convection coefficient at top, (5) Temperature of absorber plate at  $x = 0$  corresponds to that of working fluid.

**ANALYSIS:** (a) Performing an energy balance on the differential control volume,

$$q'_x + dq'_{rad} = q'_{x+dx} + dq'_{conv}$$

where

$$\begin{aligned} q'_{x+dx} &= q'_x + (dq'_x / dx) dx \\ dq'_{rad} &= q''_{rad} \cdot dx \\ dq'_{conv} &= h(T - T_\infty) \cdot dx \end{aligned}$$

Hence,

$$q''_{rad} dx = (dq'_x / dx) dx + h(T - T_\infty) dx.$$

From Fourier's law, the conduction heat rate per unit width is

$$q'_x = -k t dT/dx \quad \frac{d^2 T}{dx^2} - \frac{h}{kT} (T - T_\infty) + \frac{q''_{rad}}{kt} = 0. \quad <$$

(b) Defining  $\theta = T - T_\infty$ ,  $d^2 T/dx^2 = d^2 \theta / dx^2$  and the differential equation becomes,

$$\frac{d^2 \theta}{dx^2} - \frac{h}{kt} \theta + \frac{q''_{rad}}{kt} = 0.$$

It is a second-order, differential equation with constant coefficients and a source term, and its general solution is of the form

$$\theta = C_1 e^{+\lambda x} + C_2 e^{-\lambda x} + S/\lambda^2$$

where  $\lambda = (h/kt)^{1/2}$ ,  $S = q''_{rad} / kt$ .

Appropriate boundary conditions are:

$$\theta(0) = T_0 - T_\infty \equiv \theta_0, \quad d\theta/dx|_{x=L} = 0.$$

Hence,

$$\theta_0 = C_1 + C_2 + S/\lambda^2$$

$$d\theta/dx|_{x=L} = C_1 \lambda e^{+\lambda L} - C_2 \lambda e^{-\lambda L} = 0 \quad C_2 = C_1 e^{2\lambda L}$$

Hence,

$$C_1 = (\theta_0 - S/\lambda^2) / (1 + e^{2\lambda L}) \quad C_2 = (\theta_0 - S/\lambda^2) / (1 + e^{-2\lambda L})$$

$$\theta = (\theta_0 - S/\lambda^2) \left[ \frac{e^{\lambda x}}{1 + e^{2\lambda L}} + \frac{e^{-\lambda x}}{1 + e^{-2\lambda L}} \right] + S/\lambda^2. \quad <$$

### PROBLEM 3.112

**KNOWN:** Dimensions of a plate insulated on its bottom and thermally joined to heat sinks at its ends. Net heat flux at top surface.

**FIND:** (a) Differential equation which determines temperature distribution in plate, (b) Temperature distribution and heat loss to heat sinks.

**SCHEMATIC:**

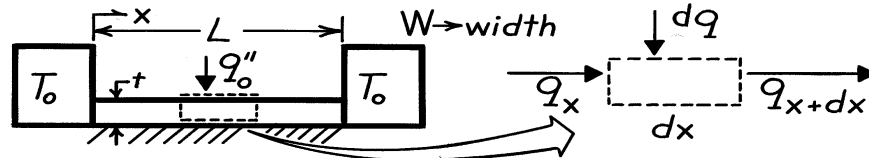

**ASSUMPTIONS:** (1) Steady-state, (2) One-dimensional conduction in  $x$  ( $W, L \gg t$ ), (3) Constant properties, (4) Uniform surface heat flux, (5) Adiabatic bottom, (6) Negligible contact resistance.

**ANALYSIS:** (a) Applying conservation of energy to the differential control volume,  $q_x + dq = q_{x+dx}$ , where  $q_{x+dx} = q_x + (dq_x/dx) dx$  and  $dq = q''_0 (W \cdot dx)$ . Hence,  $(dq_x/dx) - q''_0 W = 0$ . From Fourier's law,  $q_x = -k(t \cdot W) dT/dx$ . Hence, the differential equation for the temperature distribution is

$$-\frac{d}{dx} \left[ ktW \frac{dT}{dx} \right] - q''_0 W = 0 \quad \frac{d^2T}{dx^2} + \frac{q''_0}{kt} = 0. \quad <$$

(b) Integrating twice, the general solution is,

$$T(x) = -\frac{q''_0}{2kt} x^2 + C_1 x + C_2$$

and appropriate boundary conditions are  $T(0) = T_0$ , and  $T(L) = T_0$ . Hence,  $T_0 = C_2$ , and

$$T_0 = -\frac{q''_0}{2kt} L^2 + C_1 L + C_2 \quad \text{and} \quad C_1 = \frac{q''_0 L}{2kt}.$$

Hence, the temperature distribution is

$$T(x) = -\frac{q''_0}{2kt} (x^2 - Lx) + T_0. \quad <$$

Applying Fourier's law at  $x = 0$ , and at  $x = L$ ,

$$q(0) = -k(Wt) \left. \frac{dT}{dx} \right|_{x=0} = -kWt \left[ -\frac{q''_0}{kt} \right] \left[ x - \frac{L}{2} \right] \Big|_{x=0} = -\frac{q''_0 WL}{2}$$

$$q(L) = -k(Wt) \left. \frac{dT}{dx} \right|_{x=L} = -kWt \left[ -\frac{q''_0}{kt} \right] \left[ x - \frac{L}{2} \right] \Big|_{x=L} = +\frac{q''_0 WL}{2}$$

Hence the heat loss from the plates is  $q = 2(q''_0 WL/2) = q''_0 WL$ . <

**COMMENTS:** (1) Note signs associated with  $q(0)$  and  $q(L)$ . (2) Note symmetry about  $x = L/2$ . Alternative boundary conditions are  $T(0) = T_0$  and  $dT/dx|_{x=L/2} = 0$ .

### PROBLEM 3.113

**KNOWN:** Dimensions and surface conditions of a plate thermally joined at its ends to heat sinks at different temperatures. Heat flux into top of plate. Convection conditions beneath plate.

**FIND:** (a) Differential equation which determines temperature distribution in plate, (b) Temperature distribution and an expression for the heat rate from the plate to the sinks, and (c) Compute and plot temperature distribution and heat rates corresponding to changes in different parameters.

**SCHEMATIC:**

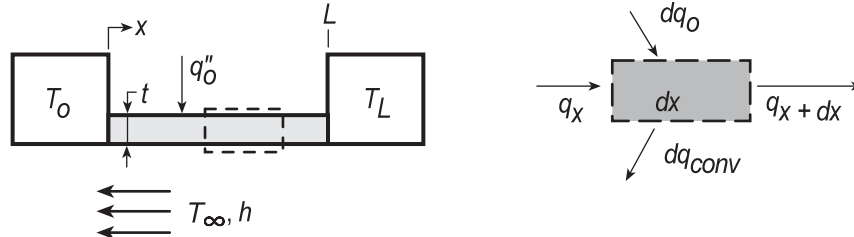

**ASSUMPTIONS:** (1) Steady-state conditions, (2) One-dimensional conduction in  $x$  ( $W, L \gg t$ ), (3) Constant properties, (4) Uniform surface heat flux and convection coefficient, (5) Negligible contact resistance.

**ANALYSIS:** (a) Applying conservation of energy to the differential control volume

$$q_x + dq_o = q_{x+dx} + dq_{conv}$$

where

$$q_{x+dx} = q_x + (dq_x/dx)dx \quad dq_{conv} = h(T - T_\infty)(W \cdot dx)$$

Hence,

$$q_x + q_o''(W \cdot dx) = q_x + (dq_x/dx)dx + h(T - T_\infty)(W \cdot dx) \quad \frac{dq_x}{dx} + hW(T - T_\infty) = q_o''W$$

Using Fourier's law,  $q_x = -k(t \cdot W)dT/dx$ ,

$$-ktW \frac{d^2T}{dx^2} + hW(T - T_\infty) = q_o''W \quad \frac{d^2T}{dx^2} - \frac{h}{kt}(T - T_\infty) + \frac{q_o''}{kt} = 0. \quad <$$

(b) Introducing  $\theta \equiv T - T_\infty$ , the differential equation becomes

$$\frac{d^2\theta}{dx^2} - \frac{h}{kt}\theta + \frac{q_o''}{kt} = 0.$$

This differential equation is of second order with constant coefficients and a source term. With

$\lambda^2 \equiv h/kt$  and  $S \equiv q_o''/kt$ , it follows that the general solution is of the form

$$\theta = C_1e^{+\lambda x} + C_2e^{-\lambda x} + S/\lambda^2. \quad (1)$$

Appropriate boundary conditions are:  $\theta(0) = T_0 - T_\infty \equiv \theta_0$   $\theta(L) = T_L - T_\infty \equiv \theta_L$  (2,3)

Substituting the boundary conditions, Eqs. (2,3) into the general solution, Eq. (1),

$$\theta_0 = C_1e^0 + C_2e^0 + S/\lambda^2 \quad \theta_L = C_1e^{+\lambda L} + C_2e^{-\lambda L} + S/\lambda^2 \quad (4,5)$$

To solve for  $C_2$ , multiply Eq. (4) by  $-e^{+\lambda L}$  and add the result to Eq. (5),

$$-\theta_0e^{+\lambda L} + \theta_L = C_2(-e^{+\lambda L} + e^{-\lambda L}) + S/\lambda^2(-e^{+\lambda L} + 1)$$

$$C_2 = \left[ (\theta_L - \theta_0e^{+\lambda L}) - S/\lambda^2(-e^{+\lambda L} + 1) \right] / (-e^{+\lambda L} + e^{-\lambda L}) \quad (6)$$

Continued...

### PROBLEM 3.113 (Cont.)

Substituting for  $C_2$  from Eq. (6) into Eq. (4), find

$$C_1 = \theta_o - \left\{ \left[ \left( \theta_L - \theta_o e^{+\lambda L} \right) - S/\lambda^2 \left( -e^{+\lambda L} + 1 \right) \right] / \left( -e^{+\lambda L} + e^{-\lambda L} \right) \right\} - S/\lambda^2 \quad (7)$$

Using  $C_1$  and  $C_2$  from Eqs. (6,7) and Eq. (1), the temperature distribution can be expressed as

$$\theta(x) = \left[ e^{+\lambda x} - \frac{\sinh(\lambda x)}{\sinh(\lambda L)} e^{+\lambda L} \right] \theta_o + \frac{\sinh(\lambda x)}{\sinh(\lambda L)} \theta_L + \left[ -\left( 1 - e^{+\lambda L} \right) \frac{\sinh(\lambda x)}{\sinh(\lambda L)} + \left( 1 - e^{+\lambda x} \right) \right] \frac{S}{\lambda^2} \quad (8) <$$

The heat rate from the plate is  $q_p = -q_x(0) + q_x(L)$  and using Fourier's law, the conduction heat rates, with  $A_c = W \cdot t$ , are

$$q_x(0) = -kA_c \left. \frac{d\theta}{dx} \right|_{x=0} = -kA_c \left\{ \left[ \lambda e^0 - \frac{e^{\lambda L}}{\sinh(\lambda L)} \lambda \right] \theta_o + \frac{\lambda}{\sinh(\lambda L)} \theta_L + \left[ -\frac{1 - e^{+\lambda L}}{\sinh(\lambda L)} \lambda - \lambda \right] \frac{S}{\lambda^2} \right\} <$$

$$q_x(L) = -kA_c \left. \frac{d\theta}{dx} \right|_{x=L} = -kA_c \left\{ \left[ \lambda e^{\lambda L} - \frac{e^{\lambda L}}{\sinh(\lambda L)} \lambda \cosh(\lambda L) \right] \theta_o + \frac{\lambda \cosh(\lambda L)}{\sinh(\lambda L)} \theta_L + \left[ -\frac{1 - e^{+\lambda L}}{\sinh(\lambda L)} \lambda \cosh(\lambda L) - \lambda e^{+\lambda L} \right] \frac{S}{\lambda^2} \right\} <$$

(c) For the prescribed base-case conditions listed below, the temperature distribution (solid line) is shown in the accompanying plot. As expected, the maximum temperature does not occur at the midpoint, but slightly toward the x-origin. The sink heat rates are

$$q_x''(0) = -17.22 \text{ W} \quad q_x''(L) = 23.62 \text{ W} \quad <$$

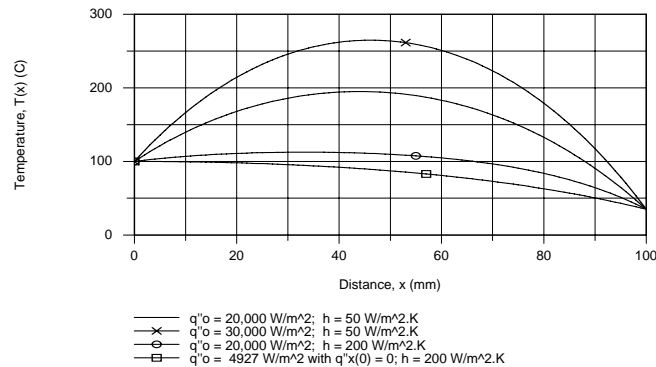

The additional temperature distributions on the plot correspond to changes in the following parameters, with all the remaining parameters unchanged: (i)  $q''_o = 30,000 \text{ W/m}^2$ , (ii)  $h = 200 \text{ W/m}^2 \cdot \text{K}$ , (iii) the value of  $q''_o$  for which  $q'_x(0) = 0$  with  $h = 200 \text{ W/m}^2 \cdot \text{K}$ . The condition for the last curve is  $q''_o = 4927 \text{ W/m}^2$  for which the temperature gradient at  $x = 0$  is zero.

Base case conditions are:  $q''_o = 20,000 \text{ W/m}^2$ ,  $T_o = 100^\circ\text{C}$ ,  $T_L = 35^\circ\text{C}$ ,  $T_\infty = 25^\circ\text{C}$ ,  $k = 25 \text{ W/m} \cdot \text{K}$ ,  $h = 50 \text{ W/m}^2 \cdot \text{K}$ ,  $L = 100 \text{ mm}$ ,  $t = 5 \text{ mm}$ ,  $W = 30 \text{ mm}$ .



### PROBLEM 3.114

**KNOWN:** Wire diameters associated with a thermocouple junction, value of the convection heat transfer coefficient.

**FIND:** Minimum wire lengths necessary to ensure the junction temperature is at the gas temperature.

**SCHEMATIC:**

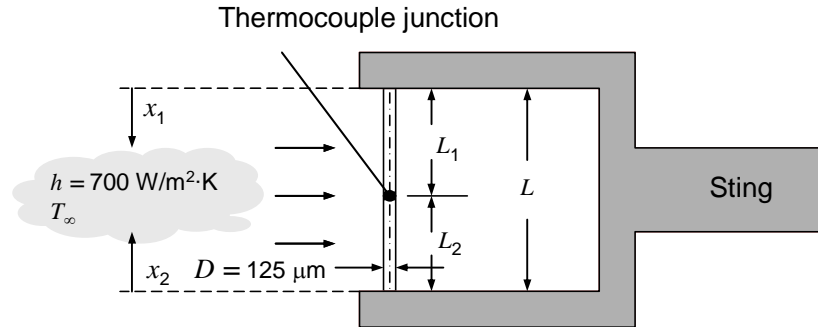

**ASSUMPTIONS:** (1) Steady-state, one-dimensional conditions, (2) Negligible radiation heat transfer, (3) Constant properties, (4) Infinitely long fin behavior.

**PROPERTIES:** Table A-1, Copper ( $\bar{T} = 300$  K):  $k = 401$  W/m·K; Constantan ( $\bar{T} = 300$  K):  $k = 23$  W/m·K; Given, Chromel:  $k = 19$  W/m·K; Alumel:  $k = 29$  W/m·K.

**ANALYSIS:** To ensure the junction temperature is at the gas temperature (that is, the junction temperature is not influenced by the sting temperature) we require the two wires to behave as infinitely long fins. From Example 3.9, Comment 1, the requirement is,

$$L_1 \geq 4.6 \left( \frac{k_1 A_c}{hP} \right)^{1/2}; L_2 \geq 4.6 \left( \frac{k_2 A_c}{hP} \right)^{1/2}$$

where  $L = L_1 + L_2$ . With  $A_c = \pi D^2/4 = \pi \times (125 \times 10^{-6} \text{ m})^2/4 = 12.27 \times 10^{-9} \text{ m}^2$  and  $P = \pi D = \pi \times 125 \times 10^{-6} \text{ m} = 393 \times 10^{-6} \text{ m}$ , we may calculate the following values of  $L_1$ ,  $L_2$ , and  $L$ .

Material	$L_1$ (mm)	$L_2$ (mm)	
(1) Copper	19.5	-	
(2) Constantan	-	4.70	
$L = L_1 + L_2$			24.2 mm <
(1) Chromel	4.24	-	
(2) Alumel	-	5.23	
$L = L_1 + L_2$			9.47 mm <

**COMMENTS:** Use of the chromel-alumel thermocouple junction leads to a substantial reduction in the size of the measurement device, while simultaneously minimizing measurement error associated with conduction along the wires to or from the sting.

### PROBLEM 3.115

**KNOWN:** Thin plastic film being bonded to a metal strip by laser heating method; strip dimensions and thermophysical properties are prescribed as are laser heating flux and convection conditions.

**FIND:** (a) Expression for temperature distribution for the region with the plastic strip,  $-w_1/2 \leq x \leq w_1/2$ , (b) Temperature at the center ( $x = 0$ ) and the edge of the plastic strip ( $x = \pm w_1/2$ ) when the laser flux is  $10,000 \text{ W/m}^2$ ; (c) Plot the temperature distribution for the strip and point out special features.

**SCHEMATIC:**

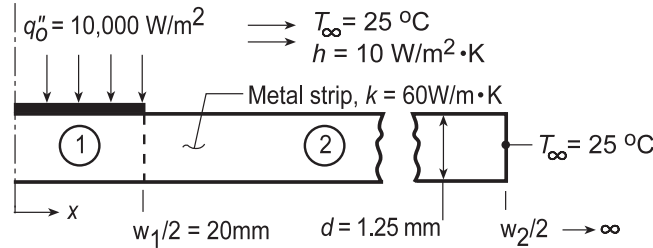

**ASSUMPTIONS:** (1) Steady-state conditions, (2) One-dimensional conduction in x-direction only, (3) Plastic film has negligible thermal resistance, (4) Upper and lower surfaces have uniform convection coefficients, (5) Edges of metal strip are at air temperature ( $T_\infty$ ), that is, strip behaves as infinite fin so that  $w_2 \rightarrow \infty$ , (6) All the incident laser heating flux  $q''_0$  is absorbed by the film, (7) Negligible radiation heat transfer.

**PROPERTIES:** Metal strip (given):  $\rho = 7850 \text{ kg/m}^3$ ,  $c_p = 435 \text{ J/kg}\cdot\text{m}^3$ ,  $k = 60 \text{ W/m}\cdot\text{K}$ .

**ANALYSIS:** (a) The strip-plastic film arrangement can be modeled as an infinite fin of uniform cross section a portion of which is exposed to the laser heat flux on the upper surface. The general solutions for the two regions of the strip, in terms of  $\theta \equiv T(x) - T_\infty$ , are

$$0 \leq x \leq w_1/2 \quad \theta_1(x) = C_1 e^{+mx} + C_2 e^{-mx} + M/m^2 \quad (1)$$

$$M = q''_0 P / 2kA_c = q''_0 / kd \quad m = (2h/kd)^{1/2} \quad (2,3)$$

$$w_1/2 \leq x \leq \infty \quad \theta_2(x) = C_3 e^{+mx} + C_4 e^{-mx} \quad (4)$$

Four boundary conditions can be identified to evaluate the constants:

$$\text{At } x = 0: \quad \frac{d\theta_1}{dx}(0) = 0 = C_1 m e^0 - C_2 m e^{-0} + 0 \rightarrow C_1 = C_2 \quad (5)$$

$$\begin{aligned} \text{At } x = w_1/2: \quad & \theta(w_1/2) = \theta_2(w_1/2) \\ & C_1 e^{+mw_1/2} + C_2 e^{-mw_1/2} + M/m^2 = C_3 e^{+mw_1/2} + C_4 e^{-mw_1/2} \end{aligned} \quad (6)$$

$$\begin{aligned} \text{At } x = w_1/2: \quad & d\theta_1(w_1/2)/dx = d\theta_2(w_1/2)/dx \\ & mC_1 e^{+mw_1/2} - mC_2 e^{-mw_1/2} + 0 = mC_3 e^{+mw_1/2} - mC_4 e^{-mw_1/2} \end{aligned} \quad (7)$$

$$\text{At } x \rightarrow \infty: \quad \theta_2(\infty) = 0 = C_3 e^\infty + C_4 e^{-\infty} \rightarrow C_3 = 0 \quad (8)$$

With  $C_3 = 0$  and  $C_1 = C_2$ , combine Eqs. (6 and 7) to eliminate  $C_4$  to find

$$C_1 = C_2 = -\frac{M/m^2}{2e^{mw_1/2}} \quad (9)$$

and using Eq. (6) with Eq. (9) find

$$C_4 = M/m^2 \sinh(mw_1/2) e^{-mw_1/2} \quad (10)$$

Continued...

### PROBLEM 3.115 (Cont.)

Hence, the temperature distribution in the region (1) under the plastic film,  $0 \leq x \leq w_1/2$ , is

$$\theta_1(x) = -\frac{M/m^2}{2e^{mw_1/2}} \left( e^{+mx} + e^{-mx} \right) + \frac{M}{m^2} = \frac{M}{m^2} \left( 1 - e^{-mw_1/2} \cosh mx \right) \quad (11) \quad \blacktriangleleft$$

and for the region (2),  $x \geq w_1/2$ ,

$$\theta_2(x) = \frac{M}{m^2} \sinh(mw_1/2) e^{-mx} \quad (12)$$

(b) Substituting numerical values into the temperature distribution expression above,  $\theta_1(0)$  and  $\theta_1(w_1/2)$  can be determined. First evaluate the following parameters:

$$M = 10,000 \text{ W/m}^2 / 60 \text{ W/m} \cdot \text{K} \times 0.00125 \text{ m} = 133,333 \text{ K/m}^2$$

$$m = \left( 2 \times 10 \text{ W/m}^2 \cdot \text{K} / 60 \text{ W/m} \cdot \text{K} \times 0.00125 \text{ m} \right)^{1/2} = 16.33 \text{ m}^{-1}$$

Hence, for the midpoint  $x = 0$ ,

$$\theta_1(0) = \frac{133,333 \text{ K/m}^2}{(16.33 \text{ m}^{-1})^2} \left[ 1 - \exp\left(-16.33 \text{ m}^{-1} \times 0.020 \text{ m}\right) \times \cosh(0) \right] = 139.3 \text{ K}$$

$$T_1(0) = \theta_1(0) + T_\infty = 139.3 \text{ K} + 25^\circ \text{C} = 164.3^\circ \text{C} \quad \blacktriangleleft$$

For the position  $x = w_1/2 = 0.020 \text{ m}$ ,

$$\theta_1(w_1/2) = 500.0 \left[ 1 - 0.721 \cosh\left(16.33 \text{ m}^{-1} \times 0.020 \text{ m}\right) \right] = 120.1 \text{ K}$$

$$T_1(w_1/2) = 120.1 \text{ K} + 25^\circ \text{C} = 145.1^\circ \text{C} \quad \blacktriangleleft$$

(c) The temperature distributions,  $\theta_1(x)$  and  $\theta_2(x)$ , are shown in the plot below. Using IHT, Eqs. (11) and (12) were entered into the workspace and a graph created. The special features are noted:

(1) No gradient at midpoint,  $x = 0$ ; symmetrical distribution.

(2) No discontinuity of gradient at  $w_1/2$  (20 mm).

(3) Temperature excess and gradient approach zero with increasing value of  $x$ .

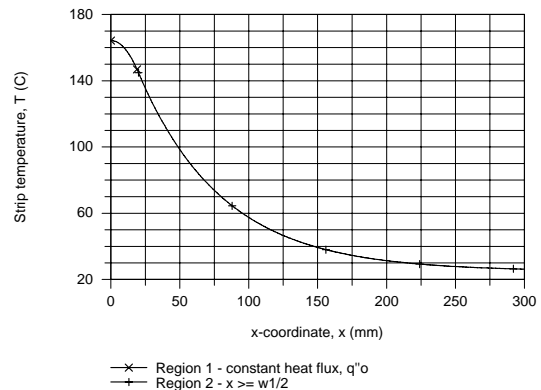

**COMMENTS:** How wide must the strip be in order to satisfy the infinite fin approximation such that  $\theta_2(x \rightarrow \infty) = 0$ ? For  $x = 200 \text{ mm}$ , find  $\theta_2(200 \text{ mm}) = 6.3^\circ \text{C}$ ; this would be a poor approximation. When  $x = 300 \text{ mm}$ ,  $\theta_2(300 \text{ mm}) = 1.2^\circ \text{C}$ ; hence when  $w_2/2 = 300 \text{ mm}$ , the strip is a reasonable approximation to an infinite fin.

### PROBLEM 3.116

**KNOWN:** Thermal conductivity, diameter and length of a wire which is annealed by passing an electrical current through the wire.

**FIND:** (a) Steady-state temperature distribution along wire, (b) Maximum wire temperature, (c) Average wire temperature.

**SCHEMATIC:**

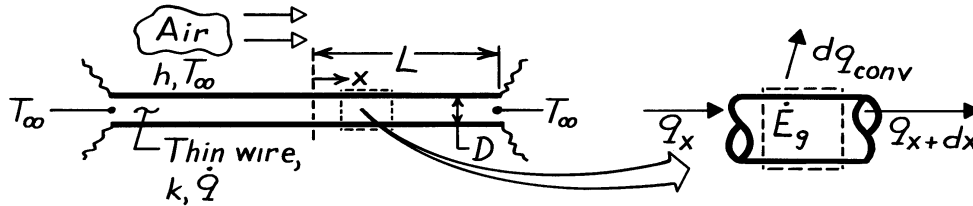

**ASSUMPTIONS:** (1) Steady-state conditions, (2) One-dimensional conduction along the wire, (3) Constant properties, (4) Negligible radiation, (5) Uniform convection coefficient  $h$ .

**ANALYSIS:** (a) Applying conservation of energy to a differential control volume,

$$q_x + \dot{E}_g - dq_{\text{conv}} - q_{x+dx} = 0$$

$$q_{x+dx} = q_x + \frac{dq_x}{dx} dx \quad q_x = -k \left( \pi D^2 / 4 \right) dT/dx$$

$$dq_{\text{conv}} = h(\pi D dx) (T - T_\infty) \quad \dot{E}_g = \dot{q} \left( \pi D^2 / 4 \right) dx.$$

Hence,

$$k \left( \pi D^2 / 4 \right) \frac{d^2 T}{dx^2} dx + \dot{q} \left( \pi D^2 / 4 \right) dx - h(\pi D dx) (T - T_\infty) = 0$$

or, with  $\theta \equiv T - T_\infty$ ,

$$\frac{d^2 \theta}{dx^2} - \frac{4h}{kD} \theta + \frac{\dot{q}}{k} = 0$$

The solution (general and particular) to this nonhomogeneous equation is of the form

$$\theta = C_1 e^{mx} + C_2 e^{-mx} + \frac{\dot{q}}{km^2}$$

where  $m^2 = (4h/kD)$ . The boundary conditions are:

$$\left. \frac{d\theta}{dx} \right|_{x=0} = 0 = m C_1 e^0 - m C_2 e^0 \rightarrow C_1 = C_2$$

$$\theta(L) = 0 = C_1 \left( e^{mL} + e^{-mL} \right) + \frac{\dot{q}}{km^2} \rightarrow C_1 = \frac{-\dot{q}/km^2}{e^{mL} + e^{-mL}} = C_2$$

Continued...

**PROBLEM 3.116 (Cont.)**

The temperature distribution has the form

$$T = T_{\infty} - \frac{\dot{q}}{km^2} \left[ \frac{e^{mx} + e^{-mx}}{e^{mL} + e^{-mL}} - 1 \right] = T_{\infty} - \frac{\dot{q}}{km^2} \left[ \frac{\cosh mx}{\cosh mL} - 1 \right]. \quad <$$

(b) The maximum wire temperature exists at  $x = 0$ . Hence,

$$T_{\max} = T(x=0) = T_{\infty} - \frac{\dot{q}}{km^2} \left[ \frac{\cosh(0)}{\cosh(mL)} - 1 \right] = T_{\infty} - \frac{\dot{q}}{km^2} \left[ \frac{1}{\cosh(mL)} - 1 \right] \quad <$$

(c) The average wire temperature may be obtained by evaluating the expression

$$\begin{aligned} \bar{T} &= \frac{1}{L} \int_{x=0}^L T(x) dx = \frac{1}{L} \int_{x=0}^L \left[ T_{\infty} - \frac{\dot{q}}{km^2} \left[ \frac{\cosh(mx)}{\cosh(mL)} - 1 \right] \right] dx \\ &= T_{\infty} + \frac{\dot{q}}{km^2} - \tanh(mL) \frac{\dot{q}}{Lkm^3} \quad < \end{aligned}$$

**COMMENTS:** (1) This process is commonly used to anneal wire and spring products. It is also used for flow measurement based upon the principle that the maximum or average wire temperature varies with the value of  $m$  and, hence, the convective heat transfer coefficient  $h$  and, ultimately, the fluid velocity. (2) To check the result of part (a), note that  $T(L) = T(-L) = T_{\infty}$ .

### PROBLEM 3.117

**KNOWN:** Electric power input and mechanical power output of a motor. Dimensions of housing, mounting pad and connecting shaft needed for heat transfer calculations. Temperature of ambient air, tip of shaft, and base of pad.

**FIND:** Housing temperature.

**SCHEMATIC:**

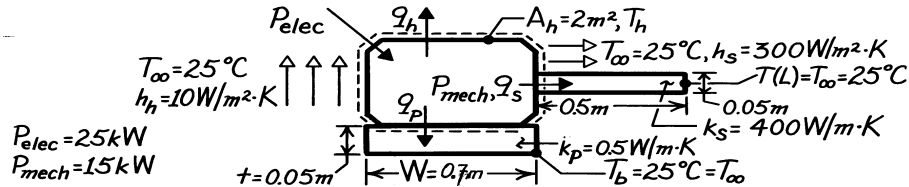

**ASSUMPTIONS:** (1) Steady-state conditions, (2) One-dimensional conduction in pad and shaft, (3) Constant properties, (4) Negligible radiation.

**ANALYSIS:** Conservation of energy yields

$$P_{elec} - P_{mech} - q_h - q_p - q_s = 0$$

$$q_h = h_h A_h (T_h - T_\infty), \quad q_p = k_p W^2 \frac{(T_h - T_\infty)}{t}, \quad q_s = M \frac{\cosh mL - \theta_L / \theta_b}{\sinh mL}$$

$$\theta_L = 0, \quad mL = \left( 4h_s L^2 / k_s D \right)^{1/2}, \quad M = \left( \frac{\pi^2}{4} D^3 h_s k_s \right)^{1/2} (T_h - T_\infty).$$

Hence

$$q_s = \frac{\left( \left[ \pi^2 / 4 \right] D^3 h_s k_s \right)^{1/2} (T_h - T_\infty)}{\tanh \left( 4h_s L^2 / k_s D \right)^{1/2}}$$

Substituting, and solving for  $(T_h - T_\infty)$ ,

$$T_h - T_\infty = \frac{P_{elec} - P_{mech}}{h_h A_h + k_p W^2 / t + \left( \left[ \pi^2 / 4 \right] D^3 h_s k_s \right)^{1/2} / \tanh \left( 4h_s L^2 / k_s D \right)^{1/2}}$$

$$\left( \left[ \pi^2 / 4 \right] D^3 h_s k_s \right)^{1/2} = 6.08 \text{ W/K}, \quad \left( 4h_s L^2 / k_s D \right)^{1/2} = 3.87, \quad \tanh mL = 0.999$$

$$T_h - T_\infty = \frac{(25 - 15) \times 10^3 \text{ W}}{\left[ 10 \times 2 + 0.5(0.7)^2 / 0.05 + 6.08 / 0.999 \right] \text{ W/K}} = \frac{10^4 \text{ W}}{(20 + 4.90 + 6.15) \text{ W/K}}$$

$$T_h - T_\infty = 322.1 \text{ K} \quad T_h = 347.1^\circ \text{C} \quad <$$

**COMMENTS:** (1)  $T_h$  is large enough to provide significant heat loss by radiation from the housing. Assuming an emissivity of 0.8 and surroundings at  $25^\circ \text{C}$ ,  $q_{rad} = \varepsilon A_h (T_h^4 - T_{sur}^4) = 4347 \text{ W}$ , which compares with  $q_{conv} = h A_h (T_h - T_\infty) = 5390 \text{ W}$ . Radiation has the effect of decreasing  $T_h$ . (2) The infinite fin approximation,  $q_s = M$ , is excellent.

### PROBLEM 3.118

**KNOWN:** Dimensions, convective conditions, bipolar plate, hydrogen and air temperatures within a fuel cell.

**FIND:** (a) The differential equation governing the membrane temperature distribution,  $T(x)$ , (b) Solution of the equation of part (a), (c) Temperature distributions associated with carbon nanotube loadings of 0 and 10 volume percent.

**SCHEMATIC:**

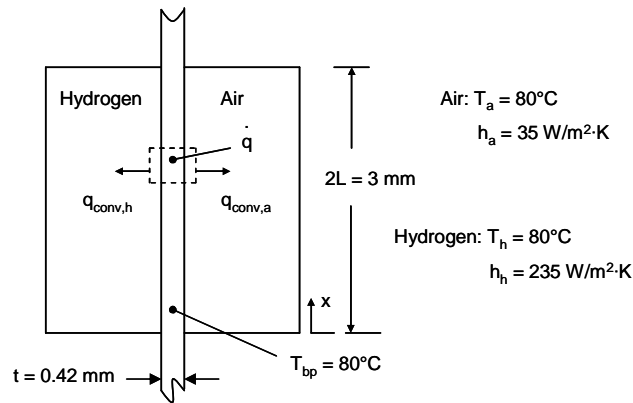

**ASSUMPTIONS:** (1) Steady-state conditions, (2) One-dimensional heat transfer, (3) Uniform volumetric energy generation, (4) Negligible contact resistance.

**ANALYSIS:**

(a) Performing an energy balance on the differential control volume,

$$q'_x + dq'_g = q'_{x+dx} + dq'_{\text{conv},a} + dq'_{\text{conv},h} \quad (1)$$

$$q'_{x+dx} = q'_x + (dq'_x/dx)dx$$

where  $dq'_g = \dot{q} \cdot t \cdot dx$ ,  $dq'_{\text{conv},a} = h_a(T - T_a)dx$ ,  $dq'_{\text{conv},h} = h_h(T - T_h)dx$

Noting that  $T_a = T_h$ , Eq. (1) becomes

$$\dot{q} \cdot t \cdot dx = (dq'_x / dx)dx + h_a(T - T_a)dx + h_h(T - T_h)dx = (dq'_x/dx)dx + [(h_a + h_h)(T - T_h)]dx$$

From Fourier's law,

$$q'_x = -kt \, dT/dx$$

and  $\frac{d^2T}{dx^2} - \frac{1}{k_{\text{eff},x} t} [(h_a + h_h)(T - T_a)] + \frac{\dot{q}}{k_{\text{eff},x}} = 0 \quad <$

Continued...

**PROBLEM 3.118 (Cont.)**

(b) Defining  $\theta = T - T_a$  and  $\frac{d^2T}{dx^2} = \frac{d^2\theta}{dx^2}$ , the differential equation becomes

$$\frac{d^2\theta}{dx^2} - \frac{(h_a + h_h)}{k_{\text{eff},x} t} \theta + \frac{\dot{q}}{k_{\text{eff},x}} = 0$$

This is the second-order, differential equation, and its general solution is of the form

$$\theta = C_1 e^{+\lambda x} + C_2 e^{-\lambda x} + S / \lambda^2$$

where  $\lambda = \left( \frac{h_a + h_h}{k_{\text{eff},x} t} \right)^{1/2}$ ,  $S = \frac{\dot{q}}{k_{\text{eff},x}}$

Appropriate boundary conditions are:

$$\theta(0) = T_0 - T_\infty = \theta_0, \quad d\theta/dx|_{x=L} = 0.$$

Hence,  $\theta_0 = C_1 + C_2 + S/\lambda^2$

$$d\theta/dx|_{x=L} = C_1 \lambda e^{+\lambda L} - C_2 \lambda e^{-\lambda L} = 0 \quad C_2 = C_1 e^{2\lambda L}$$

Hence,  $C_1 = (\theta_0 - S / \lambda^2) / (1 + e^{2\lambda L})$        $C_2 = (\theta_0 - S / \lambda^2) / (1 + e^{-2\lambda L})$

$$\theta = (\theta_0 - S / \lambda^2) \left[ \frac{e^{\lambda x}}{1 + e^{2\lambda L}} + \frac{e^{-\lambda x}}{1 + e^{-2\lambda L}} \right] + S / \lambda^2. \quad <$$

(c) For  $h_a = 35 \text{ W/m}^2 \cdot \text{K}$ ,  $h_h = 235 \text{ W/m}^2 \cdot \text{K}$  and  $k_{\text{eff},x} = 0.79 \text{ W/m} \cdot \text{K}$

$$\lambda = \left[ \frac{35 \text{ W/m}^2 \cdot \text{K} + 235 \text{ W/m}^2 \cdot \text{K}}{0.79 \text{ W/m} \cdot \text{K} \times 0.42 \times 10^{-3} \text{ m}} \right]^{1/2} = 902 \text{ m}^{-1}$$

For  $\dot{q} = 10 \times 10^6 \text{ W/m}^3$ ,  $S = \frac{10 \times 10^6 \text{ W/m}^3}{0.79 \text{ W/m} \cdot \text{K}} = 12.7 \times 10^6 \text{ K/m}^2$

The temperature distribution without, and with carbon nanotube loading, is shown below.      <

Continued...



### PROBLEM 3.118 (Cont.)

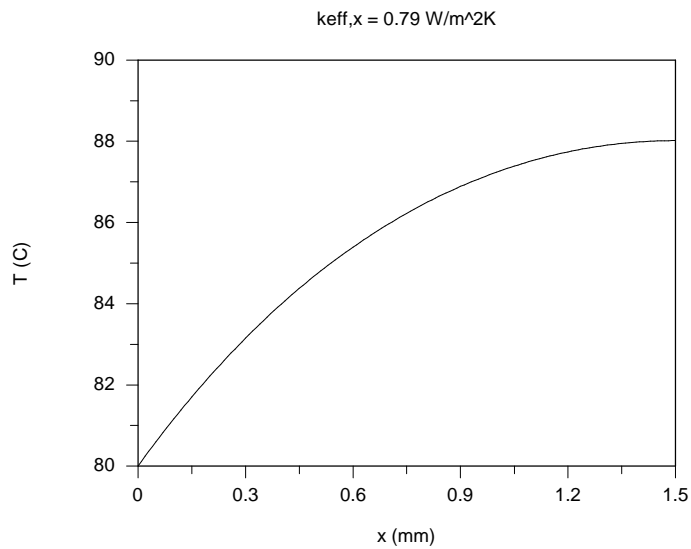

Without carbon nanotube loading.

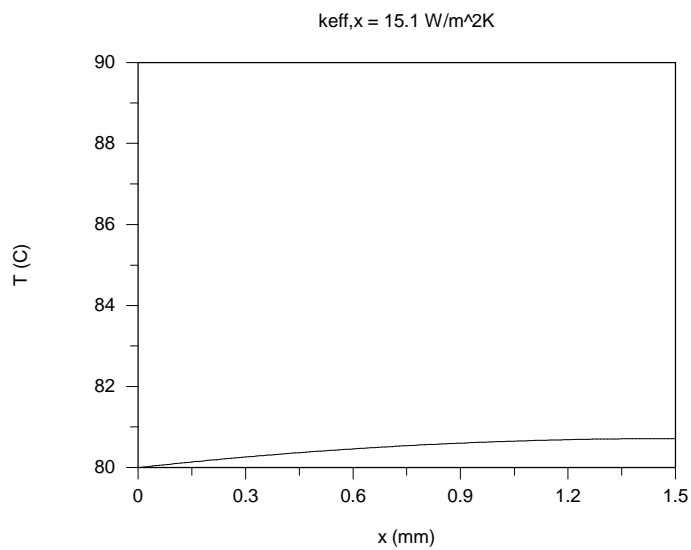

With carbon nanotube loading.

**COMMENTS:** (1) The carbon nanotubes appear to be effective in reducing the maximum temperature of the membrane. (2) Contact resistances between the bipolar plates and the membrane can be large. Hence, the actual membrane temperature will be higher than indicated with this analysis.

### PROBLEM 3.119

**KNOWN:** Rod ( $D, k, 2L$ ) that is perfectly insulated over the portion of its length  $-L \leq x \leq 0$  and experiences convection ( $T_\infty, h$ ) over the portion  $0 \leq x \leq +L$ . One end is maintained at  $T_1$  and the other is separated from a heat sink at  $T_3$  with an interfacial thermal contact resistance  $R''_{tc}$ .

**FIND:** (a) Sketch the temperature distribution  $T$  vs.  $x$  and identify key features; assume  $T_1 > T_3 > T_2$ ; (b) Derive an expression for the mid-point temperature  $T_2$  in terms of thermal and geometric parameters of the system, (c) Using numerical values, calculate  $T_2$  and plot the temperature distribution. Describe key features and compare to your sketch of part (a).

**SCHEMATIC:**

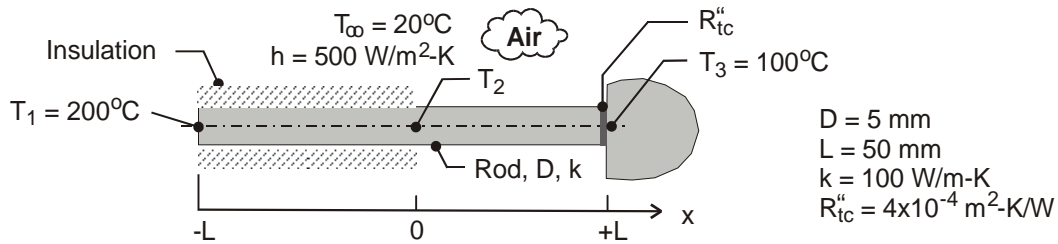

**ASSUMPTIONS:** (1) Steady-state conditions, (2) One-dimensional conduction in rod for  $-L \leq x \leq 0$ , (3) Rod behaves as one-dimensional extended surface for  $0 \leq x \leq +L$ , (4) Constant properties.

**ANALYSIS:** (a) The sketch for the temperature distribution is shown below. Over the insulated portion of the rod, the temperature distribution is linear. A temperature drop occurs across the thermal contact resistance at  $x = +L$ . The distribution over the exposed portion of the rod is non-linear. The minimum temperature of the system could occur in this portion of the rod.

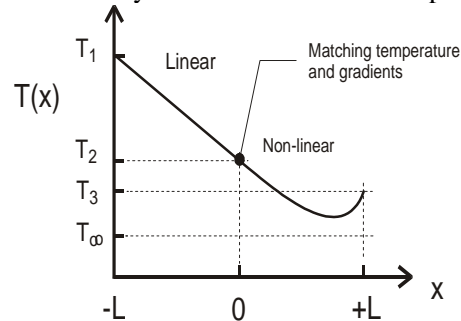

(b) To derive an expression for  $T_2$ , begin with the general solution from the conduction analysis for a fin of uniform cross-sectional area, Eq. 3.71.

$$\theta(x) = C_1 e^{mx} + C_2 e^{-mx} \quad 0 \leq x \leq +L \quad (1)$$

where  $m = (hP/kA_c)^{1/2}$  and  $\theta = T(x) - T_\infty$ . The arbitrary constants are determined from the boundary conditions.

At  $x = 0$ , thermal resistance of rod

$$q_x(0) = -kA_c \left. \frac{d\theta}{dx} \right|_{x=0} = kA_c \frac{\theta_1 - \theta(0)}{L} \quad \theta_1 = T_1 - T_\infty$$

$$-\left[ mC_1 e^0 - mC_2 e^0 \right] = \frac{1}{L} \left[ \theta_1 - (C_1 e^0 + C_2 e^0) \right] \quad (2)$$

Continued ...

**PROBLEM 3.119 (Cont.)**

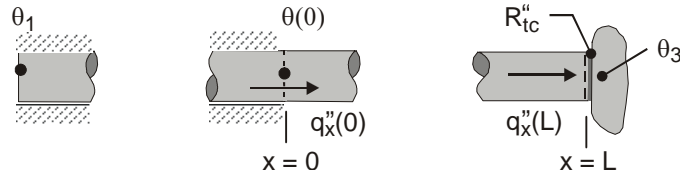

At  $x=L$ , thermal contact resistance

$$q_x(+L) = -kA_c \left. \frac{d\theta}{dx} \right|_{x=L} = \frac{\theta(L) - \theta_3}{R''_{tc} / A_c} \quad \theta_3 = T_3 - T_\infty$$

$$-k \left[ mC_1 e^{mL} - mC_2 e^{-mL} \right] = \frac{1}{R''_{tc}} \left[ C_1 e^{mL} + C_2 e^{-mL} - \theta_3 \right] \quad (3)$$

Eqs. (2) and (3) cannot be rearranged easily to find explicit forms for  $C_1$  and  $C_2$ . The constraints will be evaluated numerically in part (c). Knowing  $C_1$  and  $C_2$ , Eq. (1) gives

$$\theta_2 = \theta(0) = T_2 - T_\infty = C_1 e^0 + C_2 e^0 \quad (4)$$

(c) With Eqs. (1-4) in the *IHT Workspace* using numerical values shown in the schematic, find  $T_2 = 62.1^\circ\text{C}$ . The temperature distribution is shown in the graph below.

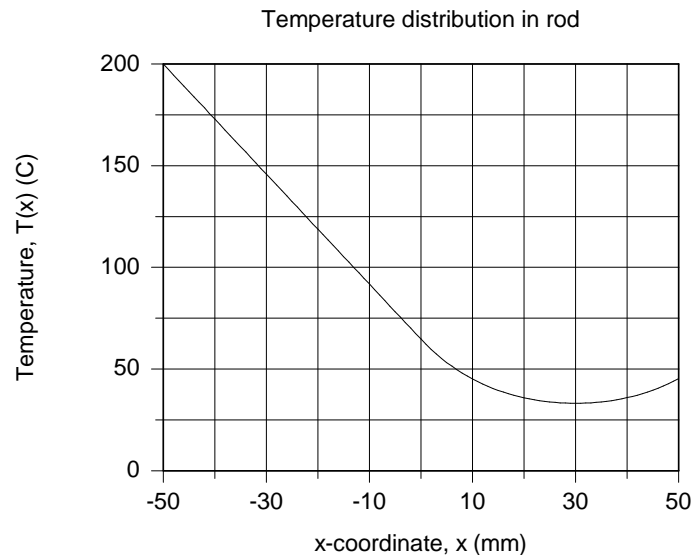

**COMMENTS:** (1) The purpose of asking you to sketch the temperature distribution in part (a) was to give you the opportunity to identify the relevant thermal processes and come to an understanding of the system behavior.

(2) Sketch the temperature distributions for the following conditions and explain their key features: (a)  $R''_{tc} = 0$ , (b)  $R''_{tc} \rightarrow \infty$ , and (c) the exposed portion of the rod behaves as an infinitely long fin; that is,  $k$  is very large.

### PROBLEM 3.120

**KNOWN:** Trench length and nanotube diameter. Laser irradiation of known power at two distinct axial locations. Measured nanotube temperatures at the trench half-width. Nanotube thermal conductivity. Island temperature.

**FIND:** Thermal contact resistances at the left and right ends of the nanotube.

**SCHEMATIC:**

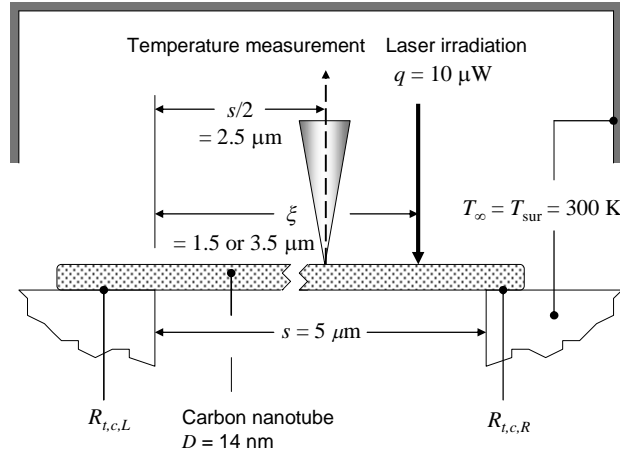

**ASSUMPTIONS:** (1) Steady-state, one-dimensional conduction. (2) Constant properties. (3) Negligible radiation and convection losses.

**ANALYSIS:** Thermal circuits may be drawn for the two laser irradiation locations as follows. The top circuit corresponds to irradiation on the left half of the nanotube. The bottom circuit corresponds to irradiation of the right half of the nanotube.

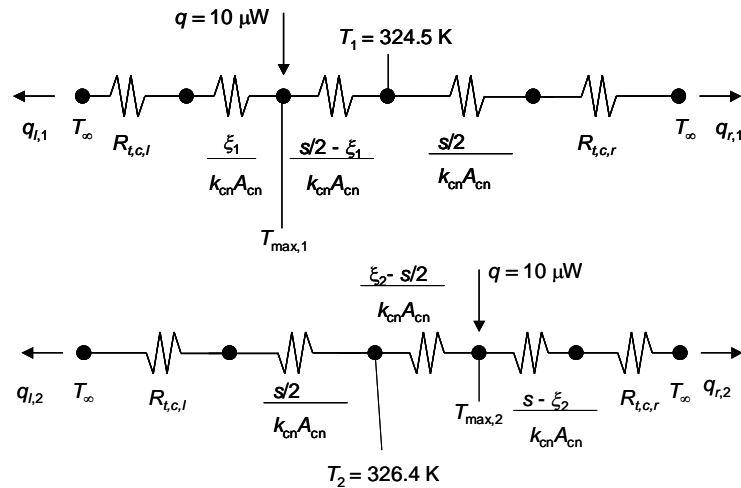

The following equations may be written for irradiation of the left side of the nanotube (top circuit).

$$q = q_{l,1} + q_{r,1} \quad (1)$$

$$q_{l,1} = \frac{T_{\max,1} - T_{\infty}}{R_{t,c,l} + \frac{\xi_1}{k_{cn}A_{cn}}} \quad (2)$$

Continued...

**PROBLEM 3.120 (Cont.)**

$$q_{r,1} = \frac{T_{\max,1} - T_{\infty}}{\frac{s/2 - \xi_1}{k_{cn} A_{cn}} + \frac{s/2}{k_{cn} A_{cn}} + R_{t,c,r}} \quad (3)$$

$$q_{r,1} = \frac{T_1 - T_{\infty}}{\frac{s/2}{k_{cn} A_{cn}} + R_{t,c,r}} \quad (4)$$

For irradiation of the right side of the nanotube (bottom circuit),

$$q = q_{l,2} + q_{r,2} \quad (5)$$

$$q_{l,2} = \frac{T_{\max,2} - T_{\infty}}{\frac{s/2}{k_{cn} A_{cn}} + \frac{\xi_2 - s/2}{k_{cn} A_{cn}} + R_{t,c,l}} \quad (6)$$

$$q_{l,2} = \frac{T_2 - T_{\infty}}{\frac{s/2}{k_{cn} A_{cn}} + R_{t,c,l}} \quad (7)$$

$$q_{r,2} = \frac{T_{\max,2} - T_{\infty}}{\frac{s - \xi_2}{k_{cn} A_{cn}} + R_{t,c,r}} \quad (8)$$

With  $k_{cn} = 3100 \text{ W/m}\cdot\text{K}$ ,  $A_{cn} = 1.54 \times 10^{-16} \text{ m}^2$ ,  $\xi_1 = 1.5 \text{ }\mu\text{m}$ ,  $T_1 = 324.5 \text{ K}$ ,  $\xi_2 = 3.5 \text{ }\mu\text{m}$ , and  $T_2 = 326.4 \text{ K}$ , Equations (1) through (8) may be solved simultaneously to yield

$$\begin{aligned} T_{\max,1} &= 331.0 \text{ K}, \quad q_{l,1} = 6.896 \times 10^{-6} \text{ W}, \quad q_{r,1} = 3.104 \times 10^{-6} \text{ W} \\ T_{\max,2} &= 334.8 \text{ K}, \quad q_{l,2} = 4.00 \times 10^{-6} \text{ W}, \quad q_{r,2} = 6.00 \times 10^{-6} \text{ W} \end{aligned}$$

and

$$R_{t,c,l} = 1.35 \times 10^6 \text{ K/W} ; \quad R_{t,c,r} = 2.65 \times 10^6 \text{ K/W} \quad <$$

**COMMENTS:** (1) Assuming large surroundings, the maximum possible radiation loss is associated with blackbody behavior and  $T_{\max,1}$ . For this situation,  $q_{\text{rad,max}} = \sigma \pi D s (T_{\max,2}^4 - T_{\text{sur}}^4) = 5.67 \times 10^{-8} \text{ W/m}^2 \cdot \text{K}^4 \times \pi \times 14 \times 10^{-9} \text{ m} \times 5 \times 10^{-6} \text{ m} \times (334.8^4 - 300^4) \text{ K}^4 = 55 \times 10^{-10} \text{ W}$ . This is much less than the laser irradiation. Therefore, radiation heat transfer is negligible. (2) The carbon nanotube is not placed symmetrically between the two islands. It is difficult to place a carbon nanotube with such accuracy.

### PROBLEM 3.121

**KNOWN:** Temperature sensing probe of thermal conductivity  $k$ , length  $L$  and diameter  $D$  is mounted on a duct wall; portion of probe  $L_i$  is exposed to water stream at  $T_{\infty,i}$  while other end is exposed to ambient air at  $T_{\infty,o}$ ; convection coefficients  $h_i$  and  $h_o$  are prescribed.

**FIND:** (a) Expression for the measurement error,  $\Delta T_{\text{err}} = T_{\text{tip}} - T_{\infty,i}$ , (b) For prescribed  $T_{\infty,i}$  and  $T_{\infty,o}$ , calculate  $\Delta T_{\text{err}}$  for immersion to total length ratios of 0.225, 0.425, and 0.625, (c) Compute and plot the effects of probe thermal conductivity and water velocity ( $h_i$ ) on  $\Delta T_{\text{err}}$ .

**SCHEMATIC:**

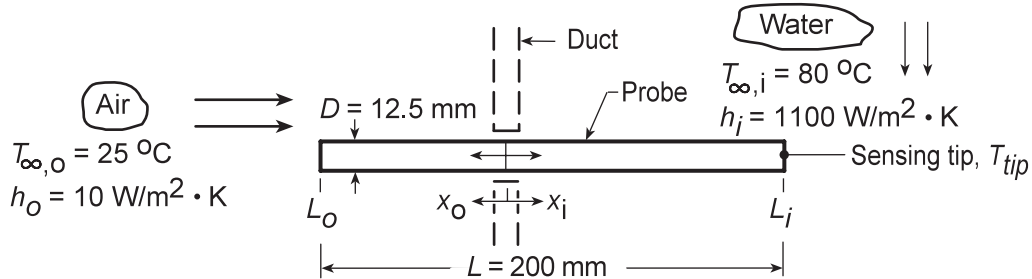

**ASSUMPTIONS:** (1) Steady-state conditions, (2) One-dimensional conduction in probe, (3) Probe is thermally isolated from the duct, (4) Convection coefficients are uniform over their respective regions.

**PROPERTIES:** Probe material (given):  $k = 177 \text{ W/m}\cdot\text{K}$ .

**ANALYSIS:** (a) To derive an expression for  $\Delta T_{\text{err}} = T_{\text{tip}} - T_{\infty,i}$ , we need to determine the temperature distribution in the immersed length of the probe  $T_i(x)$ . Consider the probe to consist of two regions:  $0 \leq x_i \leq L_i$ , the immersed portion, and  $0 \leq x_o \leq (L - L_i)$ , the ambient-air portion where the origin corresponds to the location of the duct wall. Use the results for the temperature distribution and fin heat rate of Case A, Table 3.4:

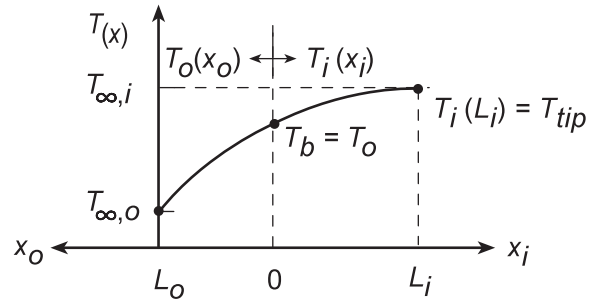

Temperature distribution in region  $i$ :

$$\frac{\theta_i}{\theta_{b,i}} = \frac{T_i(x_i) - T_{\infty,i}}{T_o - T_{\infty,i}} = \frac{\cosh(m_i(L_i - x_i)) + (h_i/m_i k) \sinh(L_i - x_i)}{\cosh(m_i L_i) + (h_i/m_i k) \sinh(m_i L_i)} \quad (1)$$

and the tip temperature,  $T_{\text{tip}} = T_i(L_i)$  at  $x_i = L_i$ , is

$$\frac{T_{\text{tip}} - T_{\infty,i}}{T_o - T_{\infty,i}} = A = \frac{\cosh(0) + (h_i/m_i k) \sinh(0)}{\cosh(m_i L_i) + (h_i/m_i k) \sinh(m_i L_i)} \quad (2)$$

and hence

$$\Delta T_{\text{err}} = T_{\text{tip}} - T_{\infty,i} = A(T_o - T_{\infty,i}) \quad (3) <$$

where  $T_o$  is the temperature at  $x_i = x_o = 0$  which at present is unknown, but can be found by setting the fin heat rates equal, that is,

$$q_{f,o} = -q_{f,i} \quad (4)$$

Continued...

**PROBLEM 3.121 (Cont.)**

$$(h_o P k A_c)^{1/2} \theta_{b,o} \cdot B = -(h_i P k A_c)^{1/2} \theta_{b,i} \cdot C$$

Solving for  $T_o$ , find

$$\frac{\theta_{b,o}}{\theta_{b,i}} = \frac{T_o - T_{\infty,o}}{T_o - T_{\infty,i}} = -\frac{(h_i P k A_c)^{1/2} C}{(h_o P k A_c)^{1/2} B} = -\left(\frac{h_i}{h_o}\right)^{1/2} \frac{C}{B}$$

$$T_o = \left[ T_{\infty,o} + \left(\frac{h_i}{h_o}\right)^{1/2} \frac{C}{B} T_{\infty,i} \right] \bigg/ \left[ 1 + \left(\frac{h_i}{h_o}\right)^{1/2} \frac{C}{B} \right] \quad (5)$$

where the constants B and C are,

$$B = \frac{\sinh(m_o L_o) + (h_o/m_o k) \cosh(m_o L_o)}{\cosh(m_o L_o) + (h_o/m_o k) \sinh(m_o L_o)} \quad (6)$$

$$C = \frac{\sinh(m_i L_i) + (h_i/m_i k) \cosh(m_i L_i)}{\cosh(m_i L_i) + (h_i/m_i k) \sinh(m_i L_i)} \quad (7)$$

(b) To calculate the immersion error for prescribed immersion lengths,  $L_i/L = 0.225, 0.425$  and  $0.625$ , we use Eq. (3) as well as Eqs. (2, 6, 7 and 5) for A, B, C, and  $T_o$ , respectively. Results of these calculations are summarized below.

$L_i/L$	$L_o$ (mm)	$L_i$ (mm)	A	B	C	$T_o$ (°C)	$\Delta T_{err}$ (°C)
0.225	155	45	0.2328	0.5865	0.9731	76.7	-0.76
0.425	115	85	0.0396	0.4639	0.992	77.5	-0.10
0.625	75	125	0.0067	0.3205	0.9999	78.2	-0.01

(c) The probe behaves as a fin having ends exposed to the cool ambient air and the hot ambient water whose temperature is to be measured. As shown above, the probe is more accurate when more of its length is exposed to the water. If the thermal conductivity is *decreased*, heat transfer along the probe length is likewise decreased, the tip temperature will be closer to the water temperature. If the velocity of the water *decreases*, the convection coefficient will decrease, and the difference between the tip and water temperatures will increase.

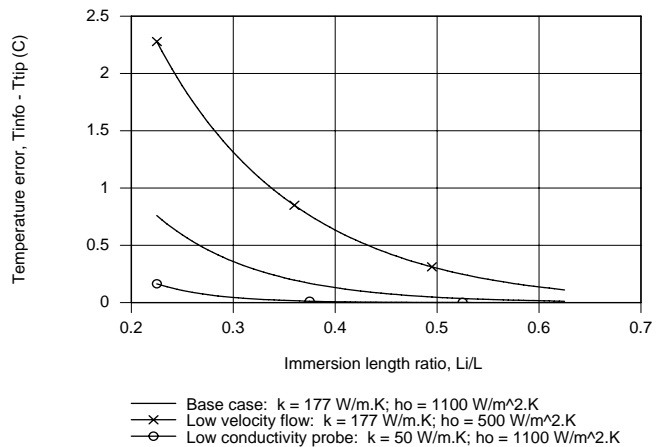

### PROBLEM 3.122

**KNOWN:** Rod protruding normally from a furnace wall covered with insulation of thickness  $L_{ins}$  with the length  $L_o$  exposed to convection with ambient air.

**FIND:** (a) An expression for the exposed surface temperature  $T_o$  as a function of the prescribed thermal and geometrical parameters. (b) Will a rod of  $L_o = 100$  mm meet the specified operating limit,  $T_o \leq 100^\circ\text{C}$ ? If not, what design parameters would you change?

**SCHEMATIC:**

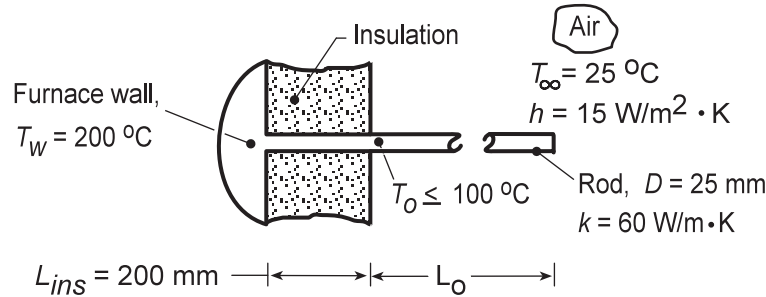

**ASSUMPTIONS:** (1) Steady-state conditions, (2) One-dimensional conduction in rod, (3) Negligible thermal contact resistance between the rod and hot furnace wall, (4) Insulated section of rod,  $L_{ins}$ , experiences no lateral heat losses, (5) Convection coefficient uniform over the exposed portion of the rod,  $L_o$ , (6) Adiabatic tip condition for the rod and (7) Negligible radiation exchange between rod and its surroundings.

**ANALYSIS:** (a) The rod can be modeled as a thermal network comprised of two resistances in series: the portion of the rod,  $L_{ins}$ , covered by insulation,  $R_{ins}$ , and the portion of the rod,  $L_o$ , experiencing convection, and behaving as a fin with an adiabatic tip condition,  $R_{fin}$ . For the insulated section:

$$R_{ins} = L_{ins}/kA_c \quad (1)$$

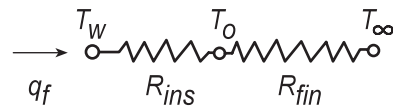

For the fin, Table 3.4, Case B, Eq. 3.81,

$$R_{fin} = \theta_b/q_f = \frac{1}{(hPkA_c)^{1/2} \tanh(mL_o)} \quad (2)$$

$$m = (hP/kA_c)^{1/2} \quad A_c = \pi D^2/4 \quad P = \pi D \quad (3,4,5)$$

From the thermal network, by inspection,

$$\frac{T_o - T_\infty}{R_{fin}} = \frac{T_w - T_\infty}{R_{ins} + R_{fin}} \quad T_o = T_\infty + \frac{R_{fin}}{R_{ins} + R_{fin}} (T_w - T_\infty) \quad (6) <$$

(b) Substituting numerical values into Eqs. (1) - (6) with  $L_o = 200$  mm,

$$T_o = 25^\circ\text{C} + \frac{6.298}{6.790 + 6.298} (200 - 25)^\circ\text{C} = 109^\circ\text{C} \quad <$$

$$R_{ins} = \frac{0.200\text{ m}}{60\text{ W/m} \cdot \text{K} \times 4.909 \times 10^{-4}\text{ m}^2} = 6.790\text{ K/W} \quad A_c = \pi (0.025\text{ m})^2 / 4 = 4.909 \times 10^{-4}\text{ m}^2$$

$$R_{fin} = 1 / \left( (0.0347\text{ W}^2/\text{K}^2) \right)^{1/2} \tanh(6.324 \times 0.200) = 6.298\text{ K/W}$$

$$(hPkA_c) = \left( 15\text{ W/m}^2 \cdot \text{K} \times \pi (0.025\text{ m}) \times 60\text{ W/m} \cdot \text{K} \times 4.909 \times 10^{-4}\text{ m}^2 \right) = 0.0347\text{ W}^2/\text{K}^2$$

Continued...



### PROBLEM 3.122 (Cont.)

$$m = (hP/kA_c)^{1/2} = \left(15 \text{ W/m}^2 \cdot \text{K} \times \pi (0.025 \text{ m}) / 60 \text{ W/m} \cdot \text{K} \times 4.909 \times 10^{-4} \text{ m}^2\right)^{1/2} = 6.324 \text{ m}^{-1}$$

Consider the following design changes aimed at reducing  $T_o \leq 100^\circ\text{C}$ . (1) Increasing length of the fin portions: with  $L_o = 400$  and  $600$  mm,  $T_o$  is  $102.8^\circ\text{C}$  and  $102.3^\circ\text{C}$ , respectively. Hence, increasing  $L_o$  will reduce  $T_o$  only modestly. (2) Decreasing the thermal conductivity: backsolving the above equation set with  $T_o = 100^\circ\text{C}$ , find the required thermal conductivity is  $k = 14 \text{ W/m}\cdot\text{K}$ . Hence, we could select a stainless steel alloy; see Table A.1. (3) Increasing the insulation thickness: find that for  $T_o = 100^\circ\text{C}$ , the required insulation thickness would be  $L_{\text{ins}} = 211$  mm. This design solution might be physically and economically unattractive. (4) A very practical solution would be to introduce thermal contact resistance between the rod base and the furnace wall by “tack welding” (rather than a continuous bead around the rod circumference) the rod in two or three places. (5) A less practical solution would be to increase the convection coefficient, since to do so, would require an air handling unit. (6) Using a tube rather than a rod will decrease  $A_c$ . For a 3 mm tube wall and 25 mm outside diameter,  $A_c = 2.07 \times 10^{-4} \text{ m}^2$ ,  $R_{\text{ins}} = 16.103 \text{ K/W}$  and  $R_{\text{fin}} = 8.61 \text{ K/W}$ , yielding  $T_o = 86^\circ\text{C}$ . (conduction within the air inside the tube is neglected).

**COMMENTS:** (1) Would replacing the rod by a thick-walled tube provide a practical solution?

(2) The *IHT Thermal Resistance Network Model* and the *Thermal Resistance Tool* for a *fin* with an *adiabatic tip* were used to create a model of the rod. The Workspace is shown below.

// Thermal Resistance Network Model:

// The Network:

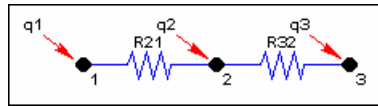

// Heat rates into node j, q<sub>ij</sub>, through thermal resistance R<sub>ij</sub>

$$q_{21} = (T_2 - T_1) / R_{21}$$

$$q_{32} = (T_3 - T_2) / R_{32}$$

// Nodal energy balances

$$q_1 + q_{21} = 0$$

$$q_2 - q_{21} + q_{32} = 0$$

$$q_3 - q_{32} = 0$$

/\* Assigned variables list: deselect the q<sub>i</sub>, R<sub>ij</sub> and T<sub>i</sub> which are unknowns; set q<sub>i</sub> = 0 for embedded nodal points at which there is no external source of heat. \*/

T1 = Tw // Furnace wall temperature, C

//q1 = // Heat rate, W

T2 = To // To, beginning of rod exposed length

q2 = 0 // Heat rate, W; node 2; no external heat source

T3 = Tinf // Ambient air temperature, C

//q3 = // Heat rate, W

// Thermal Resistances:

// Rod - conduction resistance

R21 = Lins / (k \* Ac) // Conduction resistance, K/W

Ac = pi \* D^2 / 4 // Cross sectional area of rod, m^2

// Thermal Resistance Tools - Fin with Adiabatic Tip:

R32 = Rfin // Resistance of fin, K/W

/\* Thermal resistance of a fin of uniform cross sectional area Ac, perimeter P, length L, and thermal conductivity k with an adiabatic tip condition experiencing convection with a fluid at Tinf and coefficient h, \*/

Rfin = 1 / ( tanh(m\*Lo) \* (h \* P \* k \* Ac) ^ (1/2) ) // Case B, Table 3.4

m = sqrt(h\*P / (k\*Ac))

P = pi \* D // Perimeter, m

// Other Assigned Variables:

Tw = 200 // Furnace wall temperature, C

k = 60 // Rod thermal conductivity, W/m.K

Lins = 0.200 // Insulated length, m

D = 0.025 // Rod diameter, m

h = 15 // Convection coefficient, W/m^2.K

Tinf = 25 // Ambient air temperature, C

Lo = 0.200 // Exposed length, m

### PROBLEM 3.123

**KNOWN:** Rod ( $D, k, 2L$ ) inserted into a perfectly insulating wall, exposing one-half of its length to an airstream ( $T_\infty, h$ ). An electromagnetic field induces a uniform volumetric energy generation ( $\dot{q}$ ) in the imbedded portion.

**FIND:** (a) Derive an expression for  $T_b$  at the base of the exposed half of the rod; the exposed region may be approximated as a very long fin; (b) Derive an expression for  $T_o$  at the end of the imbedded half of the rod, and (c) Using numerical values, plot the temperature distribution in the rod and describe its key features. Does the rod behave as a very long fin?

**SCHEMATIC:**

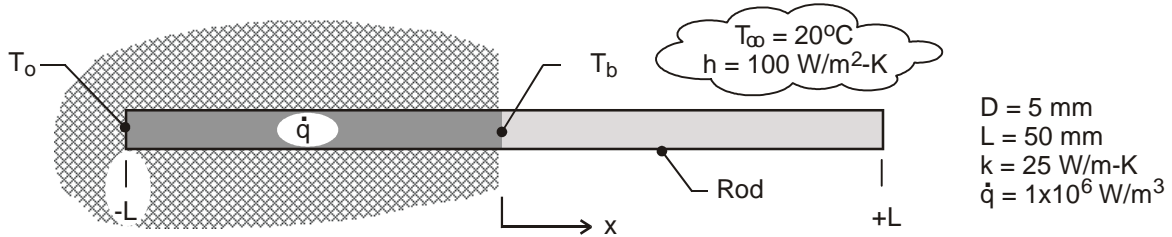

**ASSUMPTIONS:** (1) Steady-state conditions, (2) One-dimensional conduction in imbedded portion of rod, (3) Imbedded portion of rod is perfectly insulated, (4) Exposed portion of rod behaves as an infinitely long fin, and (5) Constant properties.

**ANALYSIS:** (a) Since the exposed portion of the rod ( $0 \leq x \leq +L$ ) behaves as an infinite fin, the fin heat rate using Eq. 3.85 is

$$q_x(0) = q_f = M = (hPkA_c)^{1/2} (T_b - T_\infty) \quad (1)$$

From an energy balance on the imbedded portion of the rod,

$$q_f = \dot{q} A_c L \quad (2)$$

Combining Eqs. (1) and (2), with  $P = \pi D$  and  $A_c = \pi D^2/4$ , find

$$T_b = T_\infty + q_f (hPkA_c)^{-1/2} = T_\infty + \dot{q} A_c^{1/2} L (hPk)^{-1/2} \quad (3) <$$

(b) The imbedded portion of the rod ( $-L \leq x \leq 0$ ) experiences one-dimensional heat transfer with uniform  $\dot{q}$ . From Eq. 3.48,

$$T_o = \frac{\dot{q} L^2}{2k} + T_b \quad <$$

(c) The temperature distribution  $T(x)$  for the rod is piecewise parabolic and exponential,

$$T(x) - T_b = \frac{\dot{q} L^2}{2k} \left( \frac{x}{L} \right)^2 \quad -L \leq x \leq 0$$

$$\frac{T(x) - T_\infty}{T_b - T_\infty} = \exp(-mx) \quad 0 \leq x \leq +L$$

where  $m = (hP/kA_c)^{1/2}$ .

Continued ...

### PROBLEM 3.123 (Cont.)

The gradient at  $x = 0$  will be continuous since we used this condition in evaluating  $T_b$ . The distribution is shown below with  $T_o = 105.4^\circ\text{C}$  and  $T_b = 55.4^\circ\text{C}$ .

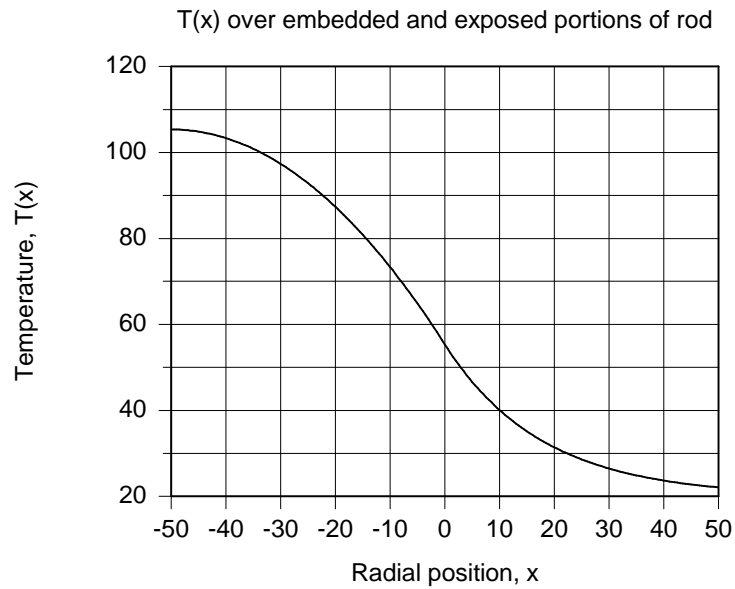

**COMMENTS:** The assumption that the rod behaves as an infinitely long fin is accurate; we see from the figure above that the temperature approaches the ambient temperature near the end of the rod.

### PROBLEM 3.124

**KNOWN:** Very long rod ( $D, k$ ) subjected to induction heating experiences uniform volumetric generation ( $\dot{q}$ ) over the center, 30-mm long portion. The unheated portions experience convection ( $T_\infty, h$ ).

**FIND:** Calculate the temperature of the rod at the mid-point of the heated portion within the coil,  $T_o$ , and at the edge of the heated portion,  $T_b$ .

**SCHEMATIC:**

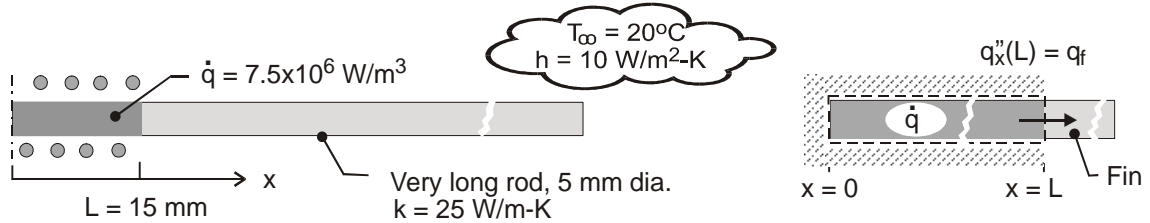

**ASSUMPTIONS:** (1) Steady-state conditions, (2) One-dimensional conduction with uniform  $\dot{q}$  in portion of rod within the coil; no convection from lateral surface of rod, (3) Exposed portions of rod behave as infinitely long fins, and (4) Constant properties, (5) Neglect radiation.

**ANALYSIS:** The portion of the rod within the coil,  $0 \leq x \leq +L$ , experiences one-dimensional conduction with uniform generation. From Eq. 3.48,

$$T_o = \frac{\dot{q}L^2}{2k} + T_b \quad (1)$$

The portion of the rod beyond the coil,  $L \leq x \leq \infty$ , behaves as an infinitely long fin for which the heat rate from Eq. 3.85 is

$$q_f = q_x(L) = (hPkA_c)^{1/2} (T_b - T_\infty) \quad (2)$$

where  $P = \pi D$  and  $A_c = \pi D^2/4$ . From an overall energy balance on the imbedded portion of the rod as illustrated in the schematic above, find the heat rate as

$$\begin{aligned} \dot{E}_{\text{in}} - \dot{E}_{\text{out}} + \dot{E}_{\text{gen}} &= 0 \\ -q_f + \dot{q}A_cL &= 0 \\ q_f &= \dot{q}A_cL \end{aligned} \quad (3)$$

Combining Eqs. (1-3),

$$T_b = T_\infty + \dot{q}A_c^{1/2}L(hPk)^{-1/2} \quad (4)$$

$$T_o = T_\infty + \frac{\dot{q}L^2}{2k} + \dot{q}A_c^{1/2}L(hPk)^{-1/2} \quad (5)$$

and substituting numerical values find

$$T_o = 305^\circ\text{C} \quad T_b = 272^\circ\text{C} \quad <$$

**COMMENT:** Assuming  $\varepsilon = 0.8$  and  $T_{\text{sur}} = T_\infty = 20^\circ\text{C}$ ,  $h_{\text{rad}} = 14.6 \text{ W/m}^2\text{-K}$ . Hence, radiation is significant and would serve to substantially reduce both  $T_o$  and  $T_b$ .

### PROBLEM 3.125

**KNOWN:** Dimensions, end temperatures and volumetric heating of wire leads. Convection coefficient and ambient temperature.

**FIND:** (a) Equation governing temperature distribution in the leads, (b) Form of the temperature distribution.

**SCHEMATIC:**

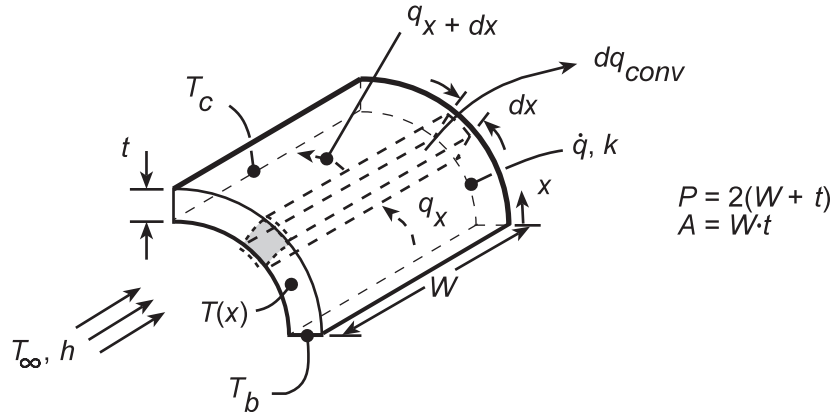

**ASSUMPTIONS:** (1) Steady-state, (2) One-dimensional conduction in  $x$ , (3) Uniform volumetric heating, (4) Uniform  $h$  (both sides), (5) Negligible radiation, (6) Constant properties.

**ANALYSIS:** (a) Performing an energy balance for the differential control volume,

$$\begin{aligned} \dot{E}_{in} - \dot{E}_{out} + \dot{E}_g &= 0 & q_x - q_{x+dx} - dq_{conv} + \dot{q}dV &= 0 \\ -kA_c \frac{dT}{dx} - \left[ -kA_c \frac{dT}{dx} - \frac{d}{dx} \left( kA_c \frac{dT}{dx} \right) dx \right] - hPdx(T - T_\infty) + \dot{q}A_c dx &= 0 \\ \frac{d^2T}{dx^2} - \frac{hP}{kA_c}(T - T_\infty) + \frac{\dot{q}}{k} &= 0 \end{aligned} \quad \leftarrow$$

(b) With a *reduced temperature* defined as  $\Theta \equiv T - T_\infty - (\dot{q}A_c/hP)$  and  $m^2 \equiv hP/kA_c$ , the differential equation may be rendered homogeneous, with a general solution and boundary conditions as shown

$$\begin{aligned} \frac{d^2\Theta}{dx^2} - m^2\Theta &= 0 & \Theta(x) &= C_1e^{mx} + C_2e^{-mx} \\ \Theta_b = C_1 + C_2 & & \Theta_c &= C_1e^{mL} + C_2e^{-mL} \end{aligned}$$

it follows that

$$\begin{aligned} C_1 &= \frac{\Theta_b e^{-mL} - \Theta_c}{e^{-mL} - e^{mL}} & C_2 &= \frac{\Theta_c - \Theta_b e^{mL}}{e^{-mL} - e^{mL}} \\ \Theta(x) &= \frac{(\Theta_b e^{-mL} - \Theta_c)e^{mx} + (\Theta_c - \Theta_b e^{mL})e^{-mx}}{e^{-mL} - e^{mL}} \end{aligned} \quad \leftarrow$$

**COMMENTS:** If  $\dot{q}$  is large and  $h$  is small, temperatures within the lead may readily exceed the prescribed boundary temperatures.

### PROBLEM 3.126

**KNOWN:** Dimensions and thermal conductivity of a gas turbine blade. Temperature and convection coefficient of gas stream. Temperature of blade base and maximum allowable blade temperature.

**FIND:** (a) Whether blade operating conditions are acceptable, (b) Heat transfer to blade coolant.

**SCHEMATIC:**

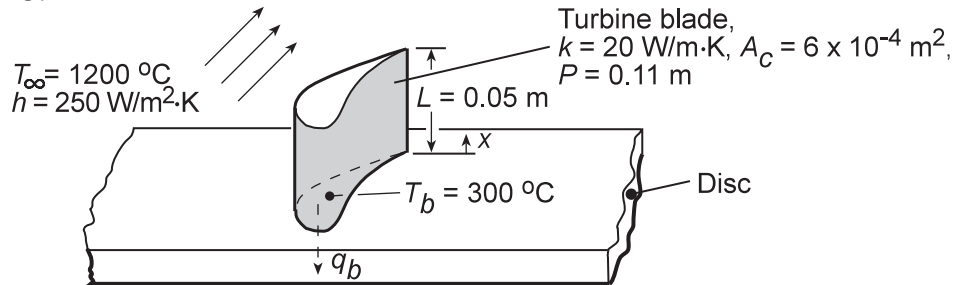

**ASSUMPTIONS:** (1) One-dimensional, steady-state conduction in blade, (2) Constant  $k$ , (3) Adiabatic blade tip, (4) Negligible radiation.

**ANALYSIS:** Conditions in the blade are determined by Case B of Table 3.4.

(a) With the maximum temperature existing at  $x = L$ , Eq. 3.80 yields

$$\frac{T(L) - T_{\infty}}{T_b - T_{\infty}} = \frac{1}{\cosh mL}$$

$$m = (hP/kA_c)^{1/2} = \left(250 \text{ W/m}^2 \cdot \text{K} \times 0.11 \text{ m} / 20 \text{ W/m} \cdot \text{K} \times 6 \times 10^{-4} \text{ m}^2\right)^{1/2}$$

$$m = 47.87 \text{ m}^{-1} \quad \text{and} \quad mL = 47.87 \text{ m}^{-1} \times 0.05 \text{ m} = 2.39$$

From Table B.1,  $\cosh mL = 5.51$ . Hence,

$$T(L) = 1200^\circ \text{C} + (300 - 1200)^\circ \text{C} / 5.51 = 1037^\circ \text{C} \quad <$$

and the operating conditions are acceptable.

(b) With  $M = (hPkA_c)^{1/2} \Theta_b = \left(250 \text{ W/m}^2 \cdot \text{K} \times 0.11 \text{ m} \times 20 \text{ W/m} \cdot \text{K} \times 6 \times 10^{-4} \text{ m}^2\right)^{1/2} (-900^\circ \text{C}) = -517 \text{ W}$ , Eq. 3.81 and Table B.1 yield

$$q_f = M \tanh mL = -517 \text{ W} (0.983) = -508 \text{ W}$$

Hence,  $q_b = -q_f = 508 \text{ W} \quad <$

**COMMENTS:** Radiation losses from the blade surface and convection from the tip will contribute to reducing the blade temperatures.

### PROBLEM 3.127

**KNOWN:** Dimensions of disc/shaft assembly. Applied angular velocity, force, and torque. Thermal conductivity and inner temperature of disc.

**FIND:** (a) Expression for the friction coefficient  $\mu$ , (b) Radial temperature distribution in disc, (c) Value of  $\mu$  for prescribed conditions.

**SCHEMATIC:**

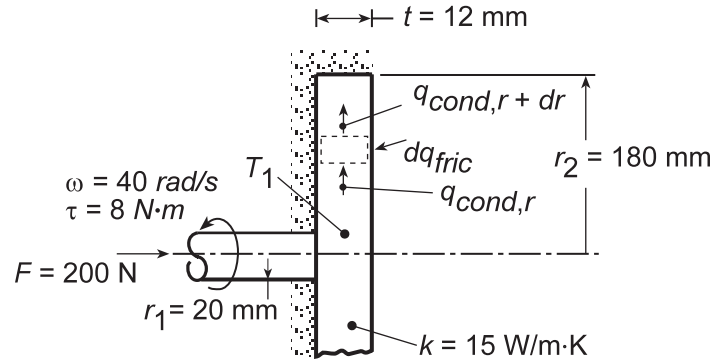

**ASSUMPTIONS:** (1) Steady-state conditions, (2) One-dimensional radial conduction, (3) Constant  $k$ , (4) Uniform disc contact pressure  $p$ , (5) All frictional heat dissipation is transferred to shaft from base of disc.

**ANALYSIS:** (a) The normal force acting on a differential ring extending from  $r$  to  $r+dr$  on the contact surface of the disc may be expressed as  $dF_n = p2\pi r dr$ . Hence, the tangential force is  $dF_t = \mu p 2\pi r dr$ , in which case the torque may be expressed as

$$d\tau = 2\pi\mu p r^2 dr$$

For the entire disc, it follows that

$$\tau = 2\pi\mu p \int_0^{r_2} r^2 dr = \frac{2\pi}{3} \mu p r_2^3$$

where  $p = F/\pi r_2^2$ . Hence,

$$\mu = \frac{3}{2} \frac{\tau}{F r_2} \quad <$$

(b) Performing an energy balance on a differential control volume in the disc, it follows that

$$q_{cond,r} + dq_{fric} - q_{cond,r+dr} = 0$$

With  $dq_{fric} = \omega d\tau = 2\mu F \omega \left( r^2/r_2^2 \right) dr$ ,  $q_{cond,r+dr} = q_{cond,r} + \left( dq_{cond,r}/dr \right) dr$ , and

$q_{cond,r} = -k(2\pi r t) dT/dr$ , it follows that

$$2\mu F \omega \left( r^2/r_2^2 \right) dr + 2\pi k t \frac{d(rdT/dr)}{dr} dr = 0$$

or

$$\frac{d(rdT/dr)}{dr} = -\frac{\mu F \omega}{\pi k t r_2^2} r^2$$

Integrating twice,

Continued...

**PROBLEM 3.127 (Cont.)**

$$\frac{dT}{dr} = -\frac{\mu F \omega}{3\pi k t r_2^2} r^2 + \frac{C_1}{r}$$

$$T = -\frac{\mu F \omega}{9\pi k t r_2^2} r^3 + C_1 \ln r + C_2$$

Since the disc is well insulated at  $r = r_2$ ,  $dT/dr|_{r_2} = 0$  and

$$C_1 = \frac{\mu F \omega r_2}{3\pi k t}$$

With  $T(r_1) = T_1$ , it also follows that

$$C_2 = T_1 + \frac{\mu F \omega}{9\pi k t r_2^2} r_1^3 - C_1 \ln r_1$$

Hence,

$$T(r) = T_1 - \frac{\mu F \omega}{9\pi k t r_2^2} (r^3 - r_1^3) + \frac{\mu F \omega r_2}{3\pi k t} \ln \frac{r}{r_1} \quad <$$

(c) For the prescribed conditions,

$$\mu = \frac{3}{2} \frac{8\text{N} \cdot \text{m}}{200\text{N}(0.18\text{m})} = 0.333 \quad <$$

Since the maximum temperature occurs at  $r = r_2$ ,

$$T_{\max} = T(r_2) = T_1 - \frac{\mu F \omega r_2}{9\pi k t} \left[ 1 - \left( \frac{r_1}{r_2} \right)^3 \right] + \frac{\mu F \omega r_2}{3\pi k t} \ln \left( \frac{r_2}{r_1} \right)$$

With  $(\mu F \omega r_2 / 3\pi k t) = (0.333 \times 200\text{N} \times 40\text{rad/s} \times 0.18\text{m} / 3\pi \times 15\text{W/m} \cdot \text{K} \times 0.012\text{m}) = 282.7^\circ\text{C}$ ,

$$T_{\max} = 80^\circ\text{C} - \frac{282.7^\circ\text{C}}{3} \left[ 1 - \left( \frac{0.02}{0.18} \right)^3 \right] + 282.7^\circ\text{C} \ln \left( \frac{0.18}{0.02} \right)$$

$$T_{\max} = 80^\circ\text{C} - 94.1^\circ\text{C} + 621.1^\circ\text{C} = 607^\circ\text{C} \quad <$$

**COMMENTS:** The maximum temperature is excessive, and the disks should be actively cooled (by convection) at their outer surfaces.



### PROBLEM 3.128

**KNOWN:** Extended surface of rectangular cross-section with heat flow in the longitudinal direction.

**FIND:** Determine the conditions for which the transverse (y-direction) temperature difference is negligible compared to the temperature difference between the surface and the environment, such that the 1-D analysis of Section 3.6.1 is valid by finding: (a) An expression for the conduction heat flux at the surface,  $q_y''(t)$ , in terms of  $T_s$  and  $T_o$ , assuming the transverse temperature distribution is parabolic, (b) An expression for the convection heat flux at the surface for the x-location; equate the two expressions, and identify the parameter that determines the ratio  $(T_o - T_s)/(T_s - T_\infty)$ ; and (c) Developing a criterion for the validity of the 1-D assumption used to model an extended surface.

**SCHEMATIC:**

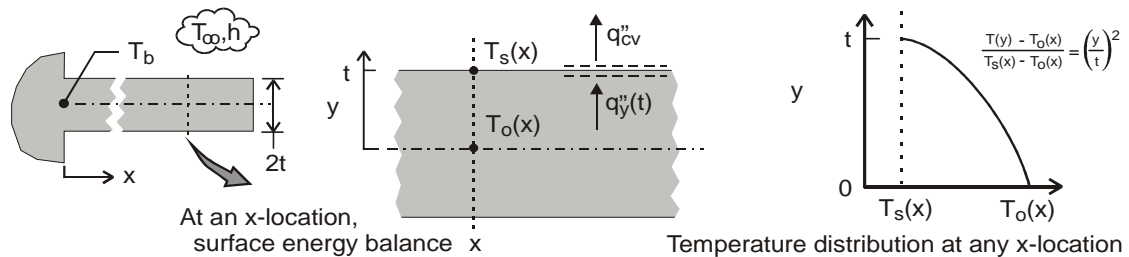

**ASSUMPTIONS:** (1) Steady-state conditions, (2) Uniform convection coefficient and (3) Constant properties.

**ANALYSIS:** (a) Referring to the schematics above, the conduction heat flux at the surface  $y = t$  at any  $x$ -location follows from Fourier's law using the parabolic transverse temperature distribution.

$$q_y''(t) = -k \left. \frac{\partial T}{\partial y} \right|_{y=t} = -k \left( [T_s(x) - T_o(x)] \frac{2y}{t^2} \right)_{y=t} = -\frac{2k}{t} [T_s(x) - T_o(x)] \quad (1)$$

(b) The convection heat flux at the surface of any  $x$ -location follows from the rate equation

$$q_{cv}'' = h [T_s(x) - T_\infty] \quad (2)$$

Performing a surface energy balance as represented schematically above, equating Eqs. (1) and (2) provides

$$\begin{aligned} q_y''(t) &= q_{cv}'' \\ -\frac{2k}{t} [T_s(x) - T_o(x)] &= h [T_s(x) - T_\infty] \\ \frac{T_s(x) - T_o(x)}{T_s(x) - T_\infty} &= -0.5 \frac{ht}{k} = -0.5 \text{ Bi} \end{aligned} \quad (3)$$

where  $\text{Bi} = ht/k$ , the Biot number, represents the ratio of the conduction to the convection thermal resistances,

$$\text{Bi} = \frac{R_{cd}''}{R_{cv}''} = \frac{t/k}{1/h} \quad (4)$$

(c) The transverse temperature difference  $(T_s - T_o)$  will be negligible compared to the temperature difference between the surface and the environment  $(T_s - T_\infty)$  when  $\text{Bi} \ll 1$ , say, 0.1, an order of magnitude smaller. This is the criterion to validate the one-dimensional assumption used to model extended surfaces.

**COMMENTS:** The coefficient 0.5 in Eq. (3) is a consequence of the parabolic distribution assumption. This distribution represents the simplest polynomial expression that could approximate the real distribution.

**PROBLEM 3.129**

**KNOWN:** Long, aluminum cylinder acts as an extended surface.

**FIND:** (a) Increase in heat transfer if diameter is tripled and (b) Increase in heat transfer if copper is used in place of aluminum.

**SCHEMATIC:**

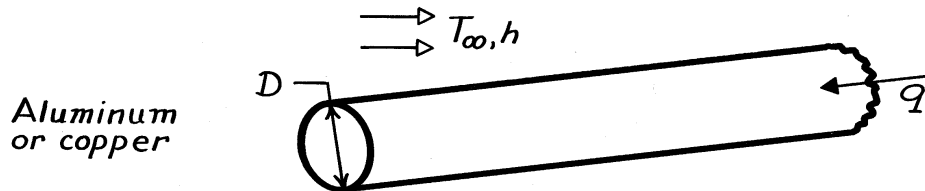

**ASSUMPTIONS:** (1) Steady-state conditions, (2) One-dimensional conduction, (3) Constant properties, (4) Uniform convection coefficient, (5) Rod is infinitely long.

**PROPERTIES:** *Table A-1*, Aluminum (pure):  $k = 240 \text{ W/m}\cdot\text{K}$ ; *Table A-1*, Copper (pure):  $k = 400 \text{ W/m}\cdot\text{K}$ .

**ANALYSIS:** (a) For an infinitely long fin, the fin heat rate from Table 3.4 is

$$q_f = M = (hPkA_c)^{1/2} \theta_b$$

$$q_f = \left( h \pi D k \pi D^2 / 4 \right)^{1/2} \theta_b = \frac{\pi}{2} (hk)^{1/2} D^{3/2} \theta_b.$$

where  $P = \pi D$  and  $A_c = \pi D^2 / 4$  for the circular cross-section. Note that  $q_f \propto D^{3/2}$ . Hence, if the diameter is tripled,

$$\frac{q_f(3D)}{q_f(D)} = 3^{3/2} = 5.2$$

and there is a 420% increase in heat transfer. <

(b) In changing from aluminum to copper, since  $q_f \propto k^{1/2}$ , it follows that

$$\frac{q_f(\text{Cu})}{q_f(\text{Al})} = \left[ \frac{k_{\text{Cu}}}{k_{\text{Al}}} \right]^{1/2} = \left[ \frac{400}{240} \right]^{1/2} = 1.29$$

and there is a 29% increase in the heat transfer rate. <

**COMMENTS:** (1) Because fin effectiveness is enhanced by maximizing  $P/A_c = 4/D$ , the use of a larger number of small diameter fins is preferred to a single large diameter fin.

(2) From the standpoint of cost, weight and machinability, aluminum is preferred over copper.

### PROBLEM 3.130

**KNOWN:** Length, diameter, base temperature and environmental conditions associated with a brass rod.

**FIND:** Temperature at specified distances along the rod.

**SCHEMATIC:**

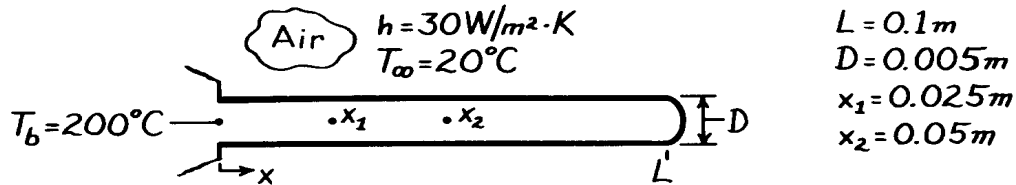

**ASSUMPTIONS:** (1) Steady-state conditions, (2) One-dimensional conduction, (3) Constant properties, (4) Negligible radiation, (5) Uniform convection coefficient  $h$ .

**PROPERTIES:** Table A-1, Brass ( $\bar{T} = 110^\circ\text{C}$ ):  $k = 133 \text{ W/m}\cdot\text{K}$ .

**ANALYSIS:** Evaluate first the fin parameter

$$m = \left[ \frac{hP}{kA_c} \right]^{1/2} = \left[ \frac{h\pi D}{k\pi D^2/4} \right]^{1/2} = \left[ \frac{4h}{kD} \right]^{1/2} = \left[ \frac{4 \times 30 \text{ W/m}^2 \cdot \text{K}}{133 \text{ W/m}\cdot\text{K} \times 0.005 \text{ m}} \right]^{1/2}$$

$$m = 13.43 \text{ m}^{-1}$$

Hence,  $mL = (13.43) \times 0.1 = 1.34$  and from the results of Example 3.9, it is advisable not to make the infinite rod approximation. Thus from Table 3.4, the temperature distribution has the form

$$\theta = \frac{\cosh m(L-x) + (h/mk) \sinh m(L-x)}{\cosh mL + (h/mk) \sinh mL} \theta_b$$

Evaluating the hyperbolic functions,  $\cosh mL = 2.04$  and  $\sinh mL = 1.78$ , and the parameter

$$\frac{h}{mk} = \frac{30 \text{ W/m}^2 \cdot \text{K}}{13.43 \text{ m}^{-1} (133 \text{ W/m}\cdot\text{K})} = 0.0168,$$

with  $\theta_b = 180^\circ\text{C}$  the temperature distribution has the form

$$\theta = \frac{\cosh m(L-x) + 0.0168 \sinh m(L-x)}{2.07} (180^\circ\text{C}).$$

The temperatures at the prescribed locations are tabulated below.

$x(\text{m})$	$\cosh m(L-x)$	$\sinh m(L-x)$	$\theta$	$T(^\circ\text{C})$	
$x_1 = 0.025$	1.55	1.19	136.5	156.5	<
$x_2 = 0.05$	1.24	0.725	108.9	128.9	<
$L = 0.10$	1.00	0.00	87.0	107.0	<

**COMMENTS:** If the rod were approximated as infinitely long:  $T(x_1) = 148.7^\circ\text{C}$ ,  $T(x_2) = 112.0^\circ\text{C}$ , and  $T(L) = 67.0^\circ\text{C}$ . The assumption would therefore result in significant underestimates of the rod temperature.

### PROBLEM 3.131

**KNOWN:** Thickness, length, thermal conductivity, and base temperature of a rectangular fin. Fluid temperature and convection coefficient.

**FIND:** (a) Heat rate per unit width, efficiency, effectiveness, thermal resistance, and tip temperature for different tip conditions, (b) Effect of convection coefficient and thermal conductivity on the heat rate.

**SCHEMATIC:**

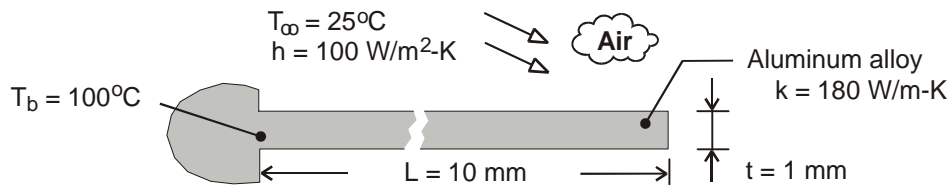

**ASSUMPTIONS:** (1) Steady-state, (2) One-dimensional conduction along fin, (3) Constant properties, (4) Negligible radiation, (5) Uniform convection coefficient, (6) Fin width is much longer than thickness ( $w \gg t$ ).

**ANALYSIS:** (a) The fin heat transfer rate for Cases A, B and D are given by Eqs. (3.77), (3.81) and (3.85), where  $M \approx (2hw^2tk)^{1/2} (T_b - T_\infty) = (2 \times 100 \text{ W/m}^2 \cdot \text{K} \times 0.001 \text{ m} \times 180 \text{ W/m} \cdot \text{K})^{1/2} (75^\circ\text{C}) w = 450 w \text{ W}$ ,  $m \approx (2h/kt)^{1/2} = (200 \text{ W/m}^2 \cdot \text{K} / 180 \text{ W/m} \cdot \text{K} \times 0.001 \text{ m})^{1/2} = 33.3 \text{ m}^{-1}$ ,  $mL \approx 33.3 \text{ m}^{-1} \times 0.010 \text{ m} = 0.333$ , and  $(h/mk) \approx (100 \text{ W/m}^2 \cdot \text{K} / 33.3 \text{ m}^{-1} \times 180 \text{ W/m} \cdot \text{K}) = 0.0167$ . From Table B-1, it follows that  $\sinh mL \approx 0.340$ ,  $\cosh mL \approx 1.057$ , and  $\tanh mL \approx 0.321$ . From knowledge of  $q_f$ , Eqs. (3.91), (3.86) and (3.88) yield

$$\eta_f \approx \frac{q'_f}{h(2L+t)\theta_b}, \quad \varepsilon_f \approx \frac{q'_f}{ht\theta_b}, \quad R'_{t,f} = \frac{\theta_b}{q'_f}$$

*Case A:* From Eq. (3.77), (3.91), (3.86), (3.88) and (3.75),

$$q'_f = \frac{M \sinh mL + (h/mk) \cosh mL}{w \cosh mL + (h/mk) \sinh mL} = 450 \text{ W/m} \frac{0.340 + 0.0167 \times 1.057}{1.057 + 0.0167 \times 0.340} = 151 \text{ W/m} \quad <$$

$$\eta_f = \frac{151 \text{ W/m}}{100 \text{ W/m}^2 \cdot \text{K} (0.021 \text{ m}) 75^\circ\text{C}} = 0.96 \quad <$$

$$\varepsilon_f = \frac{151 \text{ W/m}}{100 \text{ W/m}^2 \cdot \text{K} (0.001 \text{ m}) 75^\circ\text{C}} = 20.2, \quad R'_{t,f} = \frac{75^\circ\text{C}}{151 \text{ W/m}} = 0.50 \text{ m} \cdot \text{K/W} \quad <$$

$$T(L) = T_\infty + \frac{\theta_b}{\cosh mL + (h/mk) \sinh mL} = 25^\circ\text{C} + \frac{75^\circ\text{C}}{1.057 + (0.0167) 0.340} = 95.6^\circ\text{C} \quad <$$

*Case B:* From Eqs. (3.81), (3.91), (3.86), (3.88) and (3.80)

$$q'_f = \frac{M}{w} \tanh mL = 450 \text{ W/m} (0.321) = 144 \text{ W/m} \quad <$$

$$\eta_f = 0.92, \quad \varepsilon_f = 19.3, \quad R'_{t,f} = 0.52 \text{ m} \cdot \text{K/W} \quad <$$

$$T(L) = T_\infty + \frac{\theta_b}{\cosh mL} = 25^\circ\text{C} + \frac{75^\circ\text{C}}{1.057} = 96.0^\circ\text{C} \quad <$$

Continued ...

### PROBLEM 3.131 (Cont.)

Case D ( $L \rightarrow \infty$ ): From Eqs. (3.85), (3.91), (3.86), (3.88) and (3.84)

$$q'_f = \frac{M}{w} = 450 \text{ W/m}$$

$$\eta_f = 0, \varepsilon_f = 60.0, R'_{t,f} = 0.167 \text{ m} \cdot \text{K/W}, T(L) = T_\infty = 25^\circ\text{C}$$

(b) The effect of  $h$  on the heat rate is shown below for the aluminum and stainless steel fins.

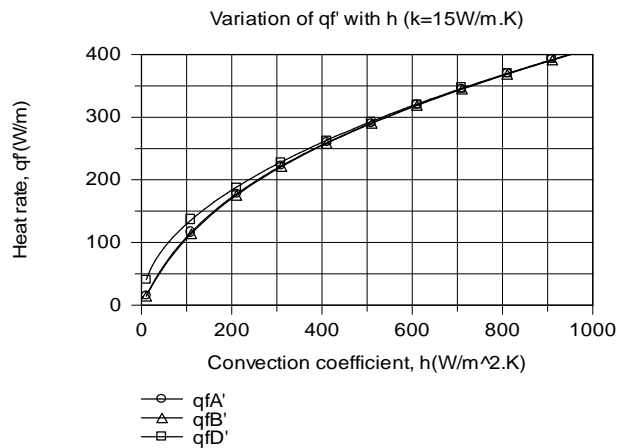
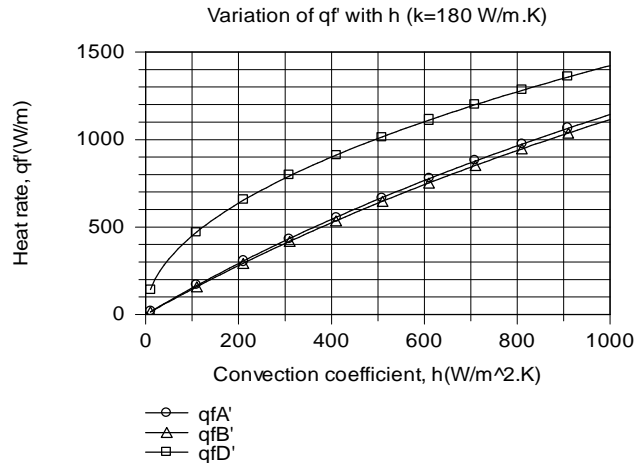

For both materials, there is little difference between the Case A and B results over the entire range of  $h$ . The difference (percentage) increases with decreasing  $h$  and increasing  $k$ , but even for the worst case condition ( $h = 10 \text{ W/m}^2\cdot\text{K}$ ,  $k = 180 \text{ W/m}\cdot\text{K}$ ), the heat rate for Case A ( $15.7 \text{ W/m}$ ) is only slightly larger than that for Case B ( $14.9 \text{ W/m}$ ). For aluminum, the heat rate is significantly over-predicted by the infinite fin approximation over the entire range of  $h$ . For stainless steel, it is over-predicted for small values of  $h$ , but results for all three cases are within 1% for  $h > 500 \text{ W/m}^2\cdot\text{K}$ .

**COMMENTS:** From the results of Part (a), we see there is a slight reduction in performance (smaller values of  $q'_f$ ,  $\eta_f$  and  $\varepsilon_f$ , as well as a larger value of  $R'_{t,f}$ ) associated with insulating the tip.

Although  $\eta_f = 0$  for the infinite fin,  $q'_f$  and  $\varepsilon_f$  are substantially larger than results for  $L = 10 \text{ mm}$ , indicating that performance may be significantly improved by increasing  $L$ .

### PROBLEM 3.132

**KNOWN:** Thermal conductivity and diameter of a pin fin. Value of the heat transfer coefficient and fin efficiency.

**FIND:** (a) Length of fin, (b) Fin effectiveness.

**SCHEMATIC:**

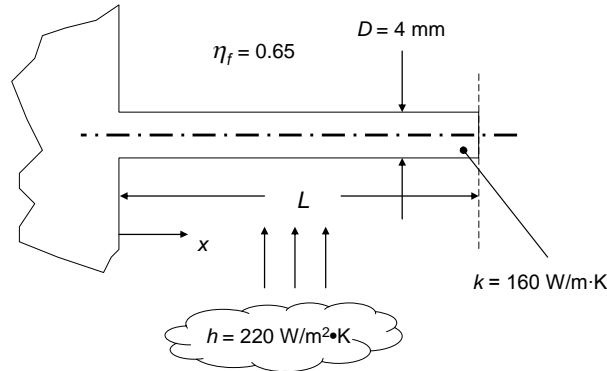

**ASSUMPTIONS:** (1) Steady-state, one-dimensional conditions, (2) Negligible radiation heat transfer, (3) Constant properties, (4) Convection from fin tip.

**PROPERTIES:** Given, Aluminum Alloy:  $k = 160 \text{ W/m}\cdot\text{K}$ .

**ANALYSIS:** For an active fin tip, the efficiency may be expressed in terms of the corrected fin length as:

$$\eta_f = \frac{\tanh(mL_c)}{mL_c}$$

where  $m = \sqrt{hP/kA_c} = \sqrt{4h/kD} = \sqrt{4 \times 220 \text{ W/m}^2 \cdot \text{K} / (160 \text{ W/m} \cdot \text{K} \times 4 \times 10^{-3} \text{ m})} = 37.1 \text{ m}^{-1}$

Hence,  $\eta_f = 0.65 = \frac{\tanh(37.1 \text{ m}^{-1} \times L_c)}{37.1 \text{ m}^{-1} \times L_c}$  which may be solved by trial-and-error (or by using *IHT*) to yield  $L_c = 0.0362 \text{ m} = 36.2 \text{ mm}$ . The fin length is therefore,  $L = L_c - D/4 = 0.0362 \text{ m} - 0.004 \text{ m}/4 = 0.0352 \text{ m} = 35.2 \text{ mm}$ . <

The fin effectiveness is:

$$\begin{aligned} \varepsilon_f &= \frac{q_f}{hA_{c,b}\theta_b} = \frac{M \tanh(mL_c)}{hA_{c,b}\theta_b} = \frac{\sqrt{hPkA_{c,b}} \tanh(mL_c)}{hA_{c,b}} = \frac{2}{\sqrt{hD/k}} \tanh(mL_c) \\ &= \frac{2}{\sqrt{\frac{220 \text{ W/m}^2 \cdot \text{K} \times 4 \times 10^{-3} \text{ m}}{160 \text{ W/m} \cdot \text{K}}}} \tanh(37.1 \text{ m}^{-1} \times 36.2 \times 10^{-3} \text{ m}) = 23.5 \end{aligned} <$$

**COMMENTS:** The values of the fin effectiveness and fin efficiency are independent of the base or fluid temperatures.

### PROBLEM 3.133

**KNOWN:** Thickness, length, thermal conductivity, and base temperature of a rectangular fin. Fluid temperature and convection coefficient.

**FIND:** (a) Heat rate per unit width, efficiency, effectiveness, thermal resistance, and tip temperature for different tip conditions, (b) Effect of fin length and thermal conductivity on the heat rate.

**SCHEMATIC:**

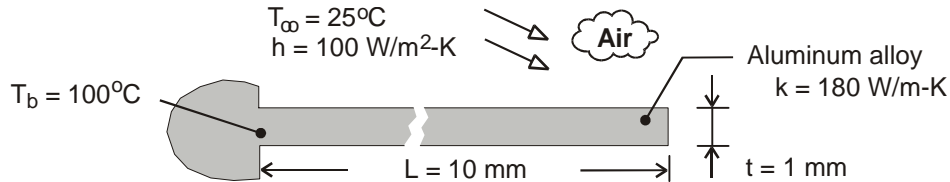

**ASSUMPTIONS:** (1) Steady-state, (2) One-dimensional conduction along fin, (3) Constant properties, (4) Negligible radiation, (5) Uniform convection coefficient, (6) Fin width is much longer than thickness ( $w \gg t$ ).

**ANALYSIS:** (a) The fin heat transfer rate for Cases A, B and D are given by Eqs. (3.77), (3.81) and (3.85), where  $M \approx (2 h w^2 t k)^{1/2} (T_b - T_\infty) = (2 \times 100 \text{ W/m}^2 \cdot \text{K} \times 0.001 \text{ m} \times 180 \text{ W/m} \cdot \text{K})^{1/2} (75^\circ\text{C}) = 450 \text{ W}$ ,  $m \approx (2h/kt)^{1/2} = (200 \text{ W/m}^2 \cdot \text{K} / 180 \text{ W/m} \cdot \text{K} \times 0.001 \text{ m})^{1/2} = 33.3 \text{ m}^{-1}$ ,  $mL \approx 33.3 \text{ m}^{-1} \times 0.010 \text{ m} = 0.333$ , and  $(h/mk) \approx (100 \text{ W/m}^2 \cdot \text{K} / 33.3 \text{ m}^{-1} \times 180 \text{ W/m} \cdot \text{K}) = 0.0167$ . From Table B-1, it follows that  $\sinh mL \approx 0.340$ ,  $\cosh mL \approx 1.057$ , and  $\tanh mL \approx 0.321$ . From knowledge of  $q_f$ , Eqs. (3.91), (3.86) and (3.88) yield

$$\eta_f \approx \frac{q'_f}{h(2L+t)\theta_b}, \quad \varepsilon_f \approx \frac{q'_f}{ht\theta_b}, \quad R'_{t,f} = \frac{\theta_b}{q'_f}$$

*Case A:* From Eq. (3.77), (3.91), (3.86), (3.88) and (3.75),

$$q'_f = \frac{M \sinh mL + (h/mk) \cosh mL}{w \cosh mL + (h/mk) \sinh mL} = 450 \text{ W/m} \frac{0.340 + 0.0167 \times 1.057}{1.057 + 0.0167 \times 0.340} = 151 \text{ W/m} \quad <$$

$$\eta_f = \frac{151 \text{ W/m}}{100 \text{ W/m}^2 \cdot \text{K} (0.021 \text{ m}) 75^\circ\text{C}} = 0.96 \quad <$$

$$\varepsilon_f = \frac{151 \text{ W/m}}{100 \text{ W/m}^2 \cdot \text{K} (0.001 \text{ m}) 75^\circ\text{C}} = 20.1, \quad R'_{t,f} = \frac{75^\circ\text{C}}{151 \text{ W/m}} = 0.50 \text{ m} \cdot \text{K/W} \quad <$$

$$T(L) = T_\infty + \frac{\theta_b}{\cosh mL + (h/mk) \sinh mL} = 25^\circ\text{C} + \frac{75^\circ\text{C}}{1.057 + (0.0167) 0.340} = 95.6^\circ\text{C} \quad <$$

*Case B:* From Eqs. (3.81), (3.91), (3.86), (3.88) and (3.80)

$$q'_f = \frac{M}{w} \tanh mL = 450 \text{ W/m} (0.321) = 144 \text{ W/m} \quad <$$

$$\eta_f = 0.92, \quad \varepsilon_f = 19.2, \quad R'_{t,f} = 0.52 \text{ m} \cdot \text{K/W} \quad <$$

$$T(L) = T_\infty + \frac{\theta_b}{\cosh mL} = 25^\circ\text{C} + \frac{75^\circ\text{C}}{1.057} = 96.0^\circ\text{C} \quad <$$

Continued .....

**PROBLEM 3.133 (Cont.)**

Case D ( $L \rightarrow \infty$ ): From Eqs. (3.85), (3.91), (3.86), (3.88) and (3.84)

$$q'_f = \frac{M}{w} = 450 \text{ W/m}$$

<

$$\eta_f = 0, \varepsilon_f = 60.0, R'_{t,f} = 0.167 \text{ m} \cdot \text{K/W}, T(L) = T_\infty = 25^\circ\text{C}$$

<

(b) The effect of  $L$  on the heat rate is shown below for the aluminum and stainless steel fins.

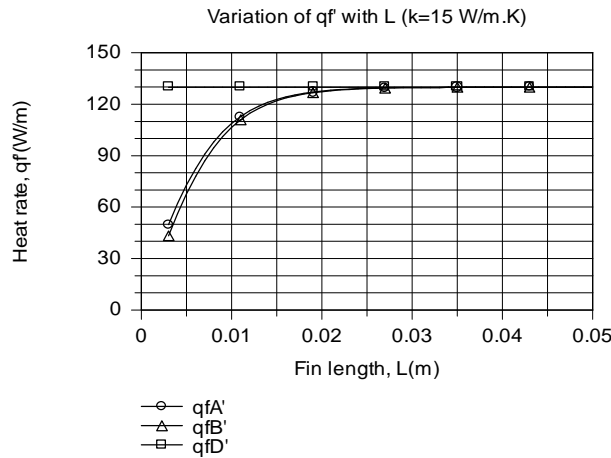
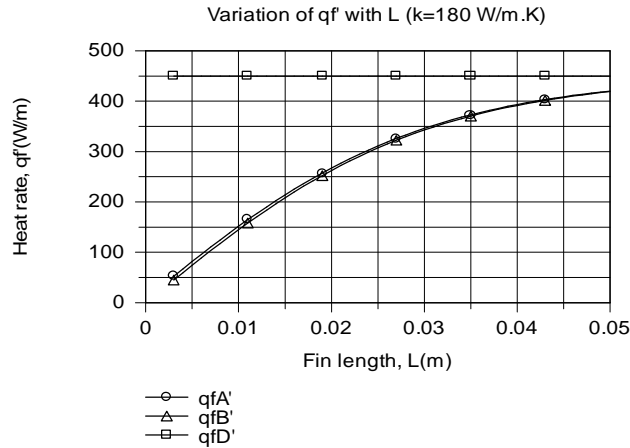

For both materials, differences between the Case A and B results diminish with increasing  $L$  and are within 1% of each other at  $L \approx 27 \text{ mm}$  and  $L \approx 13 \text{ mm}$  for the aluminum and steel, respectively. At  $L = 3 \text{ mm}$ , results differ by 14% and 13% for the aluminum and steel, respectively. The Case A and B results approach those of the infinite fin approximation more quickly for stainless steel due to the larger temperature gradients,  $|dT/dx|$ , for the smaller value of  $k$ .

**COMMENTS:** From the results of Part (a), we see there is a slight reduction in performance (smaller values of  $q'_f$ ,  $\eta_f$  and  $\varepsilon_f$ , as well as a larger value of  $R'_{t,f}$ ) associated with insulating the tip.

Although  $\eta_f = 0$  for the infinite fin,  $q'_f$  and  $\varepsilon_f$  are substantially larger than results for  $L = 10 \text{ mm}$ , indicating that performance may be significantly improved by increasing  $L$ .



### PROBLEM 3.134

**KNOWN:** Length, thickness and temperature of straight fins of rectangular, triangular and parabolic profiles. Ambient air temperature and convection coefficient.

**FIND:** Heat rate per unit width, efficiency and volume of each fin.

**SCHEMATIC:**

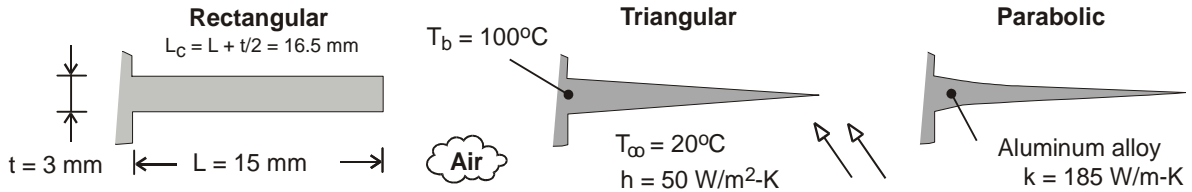

**ASSUMPTIONS:** (1) Steady-state, (2) One-dimensional conduction, (3) Constant properties, (4) Negligible radiation, (5) Uniform convection coefficient.

**ANALYSIS:** For each fin,

$$q'_f = q'_{\max} = \eta_f h A'_f \theta_b, \quad V' = A_p$$

where  $\eta_f$  depends on the value of  $m = (2h/kt)^{1/2} = (100 \text{ W/m}^2 \cdot \text{K} / 185 \text{ W/m} \cdot \text{K} \times 0.003 \text{ m})^{1/2} = 13.4 \text{ m}^{-1}$  and the product  $mL = 13.4 \text{ m}^{-1} \times 0.015 \text{ m} = 0.201$  or  $mL_c = 0.222$ . Expressions for  $\eta_f$ ,  $A'_f$  and  $A_p$  are obtained from Table 3-5.

*Rectangular Fin:*

$$\eta_f = \frac{\tanh mL_c}{mL_c} = \frac{0.218}{0.222} = 0.982, \quad A'_f = 2L_c = 0.033 \text{ m} \quad <$$

$$q' = 0.982 (50 \text{ W/m}^2 \cdot \text{K}) 0.033 \text{ m} (80^\circ\text{C}) = 129.6 \text{ W/m}, \quad V' = tL = 4.5 \times 10^{-5} \text{ m}^2 \quad <$$

*Triangular Fin:*

$$\eta_f = \frac{1}{mL} \frac{I_1(2mL)}{I_0(2mL)} = \frac{0.205}{(0.201)1.042} = 0.978, \quad A'_f = 2 \left[ L^2 + (t/2)^2 \right]^{1/2} = 0.030 \text{ m} \quad <$$

$$q' = 0.978 (50 \text{ W/m}^2 \cdot \text{K}) 0.030 \text{ m} (80^\circ\text{C}) = 117.3 \text{ W/m}, \quad V' = (t/2)L = 2.25 \times 10^{-5} \text{ m}^2 \quad <$$

*Parabolic Fin:*

$$\eta_f = \frac{2}{\left[ 4(mL)^2 + 1 \right]^{1/2} + 1} = 0.963, \quad A'_f = \left[ C_1 L + \left( L^2 / t \right) \ln(t/L + C_1) \right] = 0.030 \text{ m} \quad <$$

$$q'_f = 0.963 (50 \text{ W/m}^2 \cdot \text{K}) 0.030 \text{ m} (80^\circ\text{C}) = 115.6 \text{ W/m}, \quad V' = (t/3)L = 1.5 \times 10^{-5} \text{ m}^2 \quad <$$

**COMMENTS:** Although the heat rate is slightly larger (~10%) for the rectangular fin than for the triangular or parabolic fins, the heat rate per unit volume (or mass) is larger and largest for the triangular and parabolic fins, respectively.

### PROBLEM 3.135

**KNOWN:** Thermal conditions, base thickness, thermal conductivity, and length of a straight rectangular fin.

**FIND:** (a) Length of triangular straight fin needed to produce the same fin heat rate. Ratio of rectangular straight fin mass to triangular straight fin mass. (b) Repeat part (a) for a parabolic straight fin.

**SCHEMATIC:**

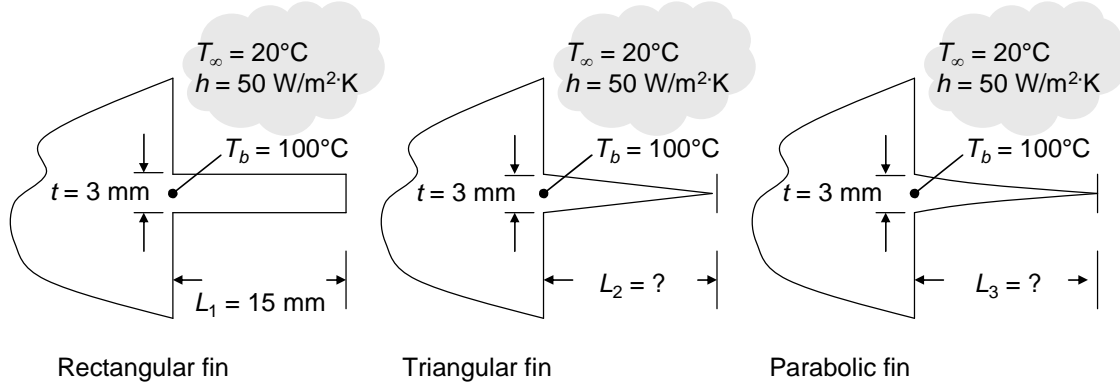

**ASSUMPTIONS:** (1) Steady-state, one-dimensional conduction, (2) Constant properties, (3) Negligible radiation.

**PROPERTIES:** Aluminum 2024: Given:  $k = 185 \text{ W/m}\cdot\text{K}$ , Table A.1:  $\rho = 2770 \text{ kg/m}^3$ .

**ANALYSIS:** For each of the fins,  $m = (2h/kt)^{1/2} = (2 \times 50 \text{ W/m}^2\cdot\text{K}/185 \text{ W/m}\cdot\text{K} \times 0.003 \text{ m})^{1/2} = 13.42 \text{ m}^{-1}$  and, for fins of unit width,  $A_{c,b} = tb = 0.003 \text{ m} \times 1 \text{ m} = 0.003 \text{ m}^2$ . Combining the definition of the fin effectiveness,  $\varepsilon_f = q_f/(hA_{c,b}\theta_b)$  and the fin efficiency,  $\eta_f = q_f/hA_f\theta_b$ , yields

$$\varepsilon_f = \eta_f A_f / A_{c,b} \quad (1)$$

*Rectangular Fin:* From Table 3.5,  $L_c = L + t/2 = 0.015 \text{ m} + 0.003 \text{ m}/2 = 0.0165 \text{ m}$ ,  $\eta_f = \tanh mL_c / (mL_c) = \tanh 13.42 \text{ m}^{-1} \times 0.0165 \text{ m} / (13.42 \text{ m}^{-1} \times 0.0165 \text{ m}) = 0.9839$ ,  $A_f = 2wL_c = 2 \times 1 \text{ m} \times 0.0165 \text{ m} = 0.033 \text{ m}^2$ . Hence,  $\varepsilon_{f1} = 0.9839 \times 0.033 \text{ m}^2 / 0.003 \text{ m}^2 = 10.83$ . The mass of the rectangular fin is  $M_1 = \rho tL = 2770 \text{ kg/m}^3 \times 0.003 \text{ m} \times 0.015 \text{ m} = 0.125 \text{ kg}$ .

(a) *Triangular Fin:* From Table 3.5,

$$A_f = 2w[L_2^2 + (t/2)^2]^{1/2} = 2 \times 1 \text{ m} \times [L_2^2 + (0.0015 \text{ m})^2]^{1/2} \quad (2a)$$

$$\eta_f = I_1(2mL_2) / [mL_2 I_0(2mL_2)] = I_1(2 \times 13.42 \text{ m}^{-1} L_2) / [13.42 \text{ m}^{-1} L_2 I_0(2 \times 13.42 \text{ m}^{-1} L_2)] \quad (2b)$$

Equating  $\varepsilon_{f2} = \varepsilon_{f1} = 10.83$ , and solving Equations (1) and 2(a, b) simultaneously yields

$$L_2 = 0.0166 \text{ m} = 16.6 \text{ mm} \quad <$$

from which  $M_2 = \rho(t/2)L_2 = 2770 \text{ kg/m}^3 \times 0.0015 \text{ m} \times 0.0166 \text{ m} = 0.069 \text{ kg}$ ;  $M_2/M_1 = 0.069 \text{ kg} / 0.126 \text{ kg} = 0.55$ .  $<$

Continued...

### PROBLEM 3.135 (Cont.)

(b) *Parabolic Fin*: From Table 3.5,

$$C_1 = [1 + (t/L_3)^2]^{1/2} = [1 + (0.003\text{m}/L_3)^2]^{1/2} \quad (3a)$$

$$A_f = w[C_1 L_3 + (L_3^2/t)\ln(t/L_3 + C_1)] = 1\text{m} \times [C_1 L_3 + (L_3^2/0.003\text{m})\ln(0.003\text{m}/L_3 + C_1)] \quad (3b)$$

$$\eta_f = 2/\{[4(mL_3)^2 + 1]^{1/2} + 1\} = 2/\{[4(13.42\text{m}^{-1}L_3)^2 + 1]^{1/2} + 1\} \quad (3c)$$

Equating  $\varepsilon_{f3} = \varepsilon_{f1} = 10.83$ , and solving Equations (1) and 3(a - c) simultaneously yields

$$L_3 = 0.0169\text{m} = 16.9\text{mm} \quad <$$

The mass of the parabolic fin is found from

$$M_3 = \rho A_p w = \rho w t L_3 / 3 = 2770\text{kg}/\text{m}^3 \times 1\text{m} \times 0.003\text{m} / 3 = 0.0468\text{kg}$$

$$\text{and } M_3/M_1 = 0.0468\text{kg}/0.126\text{kg} = 0.37. \quad <$$

**COMMENTS:** (1) The lengths of the three fins are all similar. This is because the fin efficiencies are all near unity ( $\eta_R = 0.984$ ,  $\eta_T = 0.976$ ,  $\eta_P = 0.953$ ) yielding fins of almost constant base temperature. (2) Use of triangular and parabolic fins is appropriate when weight savings is important, such as in aerospace applications. (3) Reduction in cost due to reduction in the amount of raw material used is usually offset by higher manufacturing cost for the triangular and parabolic fins.

### PROBLEM 3.136

**KNOWN:** Melting point of solder used to join two long copper rods.

**FIND:** Minimum power needed to solder the rods.

**SCHEMATIC:**

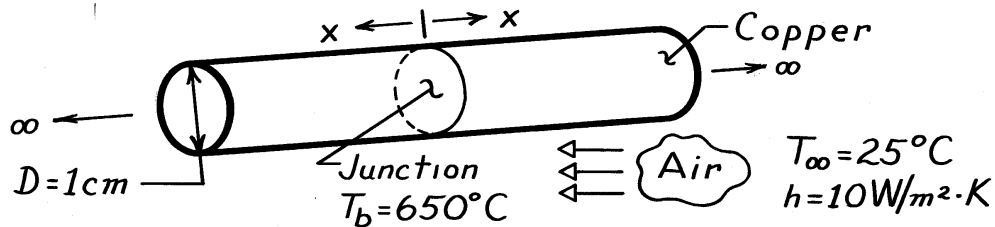

**ASSUMPTIONS:** (1) Steady-state conditions, (2) One-dimensional conduction along the rods, (3) Constant properties, (4) No internal heat generation, (5) Negligible radiation exchange with surroundings, (6) Uniform  $h$ , and (7) Infinitely long rods.

**PROPERTIES:** Table A-1: Copper  $\bar{T} = (650 + 25)^\circ\text{C} \approx 600\text{K}$ :  $k = 379\text{ W/m}\cdot\text{K}$ .

**ANALYSIS:** The junction must be maintained at  $650^\circ\text{C}$  while energy is transferred by conduction from the junction (along both rods). The minimum power is twice the fin heat rate for an infinitely long fin,

$$q_{\min} = 2q_f = 2(hPkA_c)^{1/2}(T_b - T_\infty).$$

Substituting numerical values,

$$q_{\min} = 2 \left[ 10 \frac{\text{W}}{\text{m}^2 \cdot \text{K}} (\pi \times 0.01\text{m}) \left[ 379 \frac{\text{W}}{\text{m} \cdot \text{K}} \right] \frac{\pi}{4} (0.01\text{m})^2 \right]^{1/2} (650 - 25)^\circ\text{C}.$$

Therefore,

$$q_{\min} = 120.9\text{ W}.$$

<

**COMMENTS:** Radiation losses from the rods may be significant, particularly near the junction, thereby requiring a larger power input to maintain the junction at  $650^\circ\text{C}$ .

### PROBLEM 3.137

**KNOWN:** Dimensions and end temperatures of pin fins.

**FIND:** (a) Heat transfer by convection from a single fin and (b) Total heat transfer from a  $1 \text{ m}^2$  surface with fins mounted on 4mm centers.

**SCHEMATIC:**

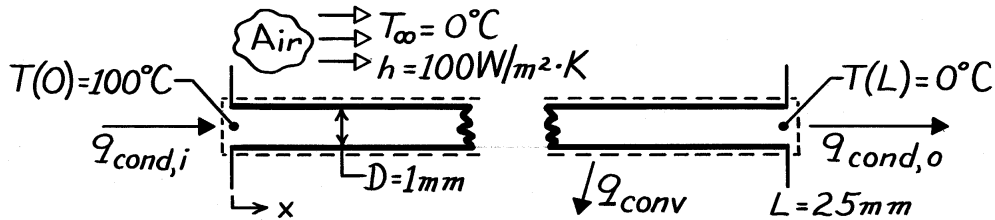

**ASSUMPTIONS:** (1) Steady-state, (2) One-dimensional conduction along rod, (3) Constant properties, (4) No internal heat generation, (5) Negligible radiation.

**PROPERTIES:** Table A-1, Copper, pure (323K):  $k \approx 400 \text{ W/m}\cdot\text{K}$ .

**ANALYSIS:** (a) By applying conservation of energy to the fin, it follows that

$$q_{\text{conv}} = q_{\text{cond},i} - q_{\text{cond},o}$$

where the conduction rates may be evaluated from knowledge of the temperature distribution. The general solution for the temperature distribution is

$$\theta(x) = C_1 e^{mx} + C_2 e^{-mx} \quad \theta \equiv T - T_\infty.$$

The boundary conditions are  $\theta(0) \equiv \theta_0 = 100^\circ\text{C}$  and  $\theta(L) = 0$ . Hence

$$\theta_0 = C_1 + C_2$$

$$0 = C_1 e^{mL} + C_2 e^{-mL}$$

Therefore,  $C_2 = C_1 e^{2mL}$

$$C_1 = \frac{\theta_0}{1 - e^{2mL}}, \quad C_2 = -\frac{\theta_0 e^{2mL}}{1 - e^{2mL}}$$

and the temperature distribution has the form

$$\theta = \frac{\theta_0}{1 - e^{2mL}} \left[ e^{mx} - e^{2mL - mx} \right].$$

The conduction heat rate can be evaluated by Fourier's law,

$$q_{\text{cond}} = -kA_c \frac{d\theta}{dx} = -\frac{kA_c \theta_0}{1 - e^{2mL}} m \left[ e^{mx} + e^{2mL - mx} \right]$$

or, with  $m = (hP/kA_c)^{1/2}$ ,

$$q_{\text{cond}} = -\frac{\theta_0 (hPkA_c)^{1/2}}{1 - e^{2mL}} \left[ e^{mx} + e^{2mL - mx} \right].$$

Continued ...

**PROBLEM 3.137 (Cont.)**

Hence at  $x = 0$ ,

$$q_{\text{cond},i} = -\frac{\theta_o (hPkA_c)^{1/2}}{1 - e^{2mL}} (1 + e^{2mL})$$

at  $x = L$

$$q_{\text{cond},o} = -\frac{\theta_o (hPkA_c)^{1/2}}{1 - e^{2mL}} (2e^{mL})$$

Evaluating the fin parameters:

$$m = \left[ \frac{hP}{kA_c} \right]^{1/2} = \left[ \frac{4h}{kD} \right]^{1/2} = \left[ \frac{4 \times 100 \text{ W/m}^2 \cdot \text{K}}{400 \text{ W/m} \cdot \text{K} \times 0.001 \text{ m}} \right]^{1/2} = 31.62 \text{ m}^{-1}$$

$$(hPkA_c)^{1/2} = \left[ \frac{\pi^2}{4} D^3 hk \right]^{1/2} = \left[ \frac{\pi^2}{4} \times (0.001 \text{ m})^3 \times 100 \frac{\text{W}}{\text{m}^2 \cdot \text{K}} \times 400 \frac{\text{W}}{\text{m} \cdot \text{K}} \right]^{1/2} = 9.93 \times 10^{-3} \frac{\text{W}}{\text{K}}$$

$$mL = 31.62 \text{ m}^{-1} \times 0.025 \text{ m} = 0.791, \quad e^{mL} = 2.204, \quad e^{2mL} = 4.865$$

The conduction heat rates are

$$q_{\text{cond},i} = \frac{-100 \text{ K} (9.93 \times 10^{-3} \text{ W/K})}{-3.865} \times 5.865 = 1.507 \text{ W}$$

$$q_{\text{cond},o} = \frac{-100 \text{ K} (9.93 \times 10^{-3} \text{ W/K})}{-3.865} \times 4.408 = 1.133 \text{ W}$$

and from the conservation relation,

$$q_{\text{conv}} = 1.507 \text{ W} - 1.133 \text{ W} = 0.374 \text{ W}. \quad \leftarrow$$

(b) The total heat transfer rate is the heat transfer from  $N = 250 \times 250 = 62,500$  rods and the heat transfer from the remaining (bare) surface ( $A = 1 \text{ m}^2 - NA_c$ ). Hence,

$$q = N q_{\text{cond},i} + hA\theta_o = 62,500 (1.507 \text{ W}) + 100 \text{ W/m}^2 \cdot \text{K} (0.951 \text{ m}^2) 100 \text{ K}$$

$$q = 9.42 \times 10^4 \text{ W} + 0.95 \times 10^4 \text{ W} = 1.037 \times 10^5 \text{ W}.$$

**COMMENTS:** (1) The fins, which cover only 5% of the surface area, provide for more than 90% of the heat transfer from the surface.

(2) The fin effectiveness,  $\varepsilon \equiv q_{\text{cond},i} / hA_c\theta_o$ , is  $\varepsilon = 192$ , and the fin efficiency,

$\eta \equiv (q_{\text{conv}} / h\pi DL\theta_o)$ , is  $\eta = 0.48$ .

(3) The temperature distribution,  $\theta(x)/\theta_o$ , and the conduction term,  $q_{\text{cond},i}$ , could have been obtained directly from Eqs. 3.82 and 3.83, respectively.

(4) Heat transfer by convection from a single fin could also have been obtained from Eq. 3.78.

### PROBLEM 3.138

**KNOWN:** Dimensions of a nanospring, dependence of pitch upon temperature.

**FIND:** Actuation distance of the spring in response to heating of its end, accuracy to which the actuation length can be controlled.

**SCHEMATIC:**

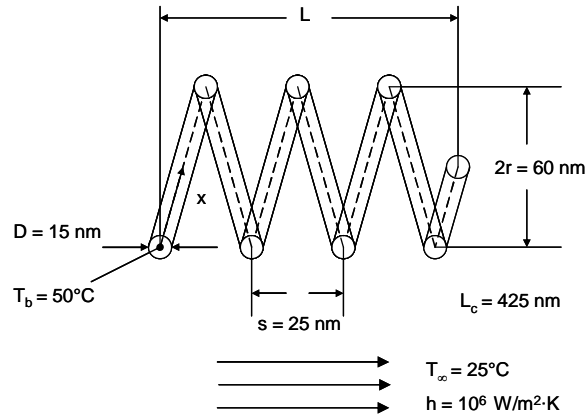

**ASSUMPTIONS:** (1) Constant properties, (2) Steady-state conditions, (3) One-dimensional heat transfer, (4) Adiabatic tip, (5) Negligible radiation heat transfer, (6) Negligible impact of nanoscale heat transfer effects.

**PROPERTIES:** Table A.2, silicon carbide (300 K):  $k = 490 \text{ W/m}\cdot\text{K}$ .

**ANALYSIS:** When the nanospring is at  $T_i = 25^\circ\text{C}$ , the spring length is

$$L_i = \frac{s}{2\pi} \frac{L_c}{\sqrt{r^2 + (S/2\pi)^2}} = \frac{25 \times 10^{-9} \text{ m}}{2\pi} \times \frac{425 \times 10^{-9} \text{ m}}{\sqrt{(30 \times 10^{-9} \text{ m})^2 + \left(\frac{25 \times 10^{-9} \text{ m}}{2\pi}\right)^2}}$$

$$= 55.9 \times 10^{-9} \text{ m} = 55.9 \text{ nm}$$

Since the average spring pitch varies linearly with the average temperature, the average pitch of the heated spring is

$$\bar{s} = s_i + \frac{d\bar{s}}{dT} (\bar{T} - T_i) \quad (1)$$

The average excess temperature is

$$\bar{\theta} = \bar{T} - T_\infty = \frac{1}{L_c} \int_{x=0}^{L_c} \theta(x) dx \quad \text{where, from Eq. 3.80,}$$

Continued...

**PROBLEM 3.138 (Cont.)**

$$\bar{\theta} = \frac{\theta_b}{L_c} \int_{x=0}^{L_c} \frac{\cosh m(L-x)}{\cosh mL} dx = - \frac{\theta_b}{mL_c (\cosh mL_c)} \sinh m(L_c - x) \Big|_0^{L_c}$$

$$\bar{\theta} = \frac{\theta_b}{mL_c (\cosh mL_c)} \times (0 - \sinh mL_c) = \frac{\theta_b}{mL_c} \tanh (mL_c)$$

For a particular spring,

$$mL_c = \left( \frac{hP}{kA_c} \right)^{1/2} L_c = \left( \frac{4h}{kD} \right)^{1/2} L_c = \left( \frac{4 \times 10^6 \text{ W/m}^2 \cdot \text{K}}{490 \text{ W/m} \cdot \text{K} \times 15 \times 10^{-9} \text{ m}} \right)^{1/2} \times 425 \times 10^{-9} \text{ m} = 0.314$$

Therefore  $\bar{\theta} = \frac{(50 - 25)^\circ\text{C}}{0.314} \tanh (0.314) = 24.2^\circ\text{C}$

and  $\bar{T} = \bar{\theta} + T_\infty = 24.2^\circ\text{C} + 25^\circ\text{C} = 49.2^\circ\text{C}$

From Eq. (1),

$$\bar{s} = 25 \times 10^{-9} \text{ m} + 0.1 \times 10^{-9} \text{ m/K} \times (49.2 - 25)^\circ\text{C} = 27.4 \times 10^{-9} \text{ m}$$

Therefore,

$$L_2 = \frac{27.4 \times 10^{-9} \text{ m}}{2\pi} \times \frac{425 \times 10^{-9} \text{ m}}{\sqrt{(30 \times 10^{-9} \text{ m})^2 + (27.4 \times 10^{-9} \text{ m}/2\pi)^2}} = 61.1 \times 10^{-9} \text{ m} = 61.1 \text{ nm}$$

and the actuation length is

$$\Delta L = L_2 - L_1 = 61.1 \text{ nm} - 55.9 \text{ nm} = 5.2 \text{ nm} \quad <$$

If the base temperature can be controlled to within 1 degree Celsius, the resolution of the

actuation length is:  $R = \Delta L \times \frac{1 \text{ degree C}}{25 \text{ degree C}} = 0.2 \text{ nm} \quad <$

**COMMENTS:** (1) The actuation distance and its resolution are extremely small. (2) Application of other tip conditions will lead to different predictions of the actuation distance.



### PROBLEM 3.139

**KNOWN:** Positions of equal temperature on two long rods of the same diameter, but different thermal conductivity, which are exposed to the same base temperature and ambient air conditions.

**FIND:** Thermal conductivity of rod B,  $k_B$ .

**SCHEMATIC:**

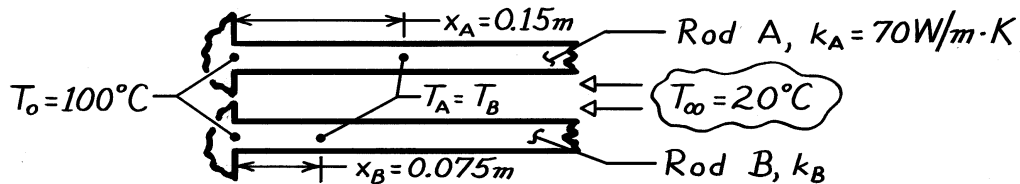

**ASSUMPTIONS:** (1) Steady-state conditions, (2) Rods are infinitely long fins of uniform cross-sectional area, (3) Uniform heat transfer coefficient, (4) Constant properties.

**ANALYSIS:** The temperature distribution for the infinite fin has the form

$$\frac{\theta}{\theta_b} = \frac{T(x) - T_\infty}{T_o - T_\infty} = e^{-mx} \quad m = \left[ \frac{hP}{kA_c} \right]^{1/2} \quad (1,2)$$

For the two positions prescribed,  $x_A$  and  $x_B$ , it was observed that

$$T_A(x_A) = T_B(x_B) \quad \text{or} \quad \theta_A(x_A) = \theta_B(x_B). \quad (3)$$

Since  $\theta_b$  is identical for both rods, Eq. (1) with the equality of Eq. (3) requires that

$$m_A x_A = m_B x_B$$

Substituting for  $m$  from Eq. (2) gives

$$\left[ \frac{hP}{k_A A_c} \right]^{1/2} x_A = \left[ \frac{hP}{k_B A_c} \right]^{1/2} x_B.$$

Recognizing that  $h$ ,  $P$  and  $A_c$  are identical for each rod and rearranging,

$$k_B = \left[ \frac{x_B}{x_A} \right]^2 k_A$$

$$k_B = \left[ \frac{0.075\text{ m}}{0.15\text{ m}} \right]^2 \times 70 \text{ W/m} \cdot \text{K} = 17.5 \text{ W/m} \cdot \text{K}. \quad <$$

**COMMENTS:** This approach has been used as a method for determining the thermal conductivity. It has the attractive feature of not requiring power or temperature measurements, assuming of course, a reference material of known thermal conductivity is available.

### PROBLEM 3.140

**KNOWN:** Dimension and length of an aluminum pin fin. Base and ambient temperatures, value of the convection heat transfer coefficient.

**FIND:** (a) Fin heat transfer rate with an adiabatic tip, (b) Fin heat transfer rate when the fin tip is cooled below the ambient temperature, (c) Temperature distribution along the fin for parts (a) and (b), (d) Fin heat rates for  $0 \leq h \leq 1000 \text{ W/m}^2\cdot\text{K}$ .

**SCHEMATIC:**

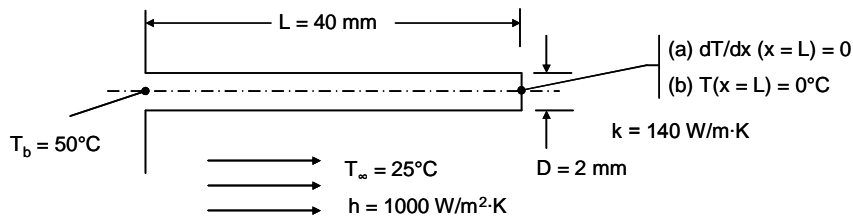

**ASSUMPTIONS:** (1) Constant properties, (2) Steady-state conditions, (3) One-dimensional heat transfer, (4) Negligible radiation heat transfer.

**ANALYSIS:**

(a) The fin heat transfer rate is given by Eq. 3.81;  $q_f = M \tanh ml$  where

$$\begin{aligned} M &= \sqrt{hPkA_c} \theta_b \\ &= \sqrt{1000 \text{ W/m}^2 \cdot \text{K} \times \pi \times 2 \times 10^{-3} \text{ m} \times 140 \text{ W/m} \cdot \text{K} \times \pi \times (2 \times 10^{-3} \text{ m})^2/4 \times (50 - 25)^\circ\text{C}} \\ &= 1.314 \text{ W} \end{aligned}$$

and

$$m = \sqrt{\frac{hP}{kA_c}} = \sqrt{\frac{1000 \text{ W/m}^2 \cdot \text{K} \times \pi \times 2 \times 10^{-3} \text{ m}}{140 \text{ W/m}^2 \cdot \text{K} \times \pi \times (2 \times 10^{-3} \text{ m})^2/4}} = 119.5 \text{ m}^{-1}$$

Therefore,  $q_f = 1.314 \text{ W} \tanh (119.5 \text{ m}^{-1} \times 40 \times 10^{-3} \text{ m}) = 1.314 \text{ W}$  <

(b) For the case where  $T(x = L) = 0^\circ\text{C}$ , the fin heat transfer rate is

$$\begin{aligned} q_f &= M \frac{(\cosh ml - \theta_L/\theta_b)}{\sinh ml} \\ &= 1.314 \text{ W} \times \frac{\cosh (119.5 \text{ m}^{-1} \times 40 \times 10^{-3} \text{ m}) - (0 - 25)^\circ\text{C} / (50 - 25)^\circ\text{C}}{\sinh (119.5 \text{ m}^{-1} \times 40 \times 10^{-3} \text{ m})} = 1.336 \text{ W} < \end{aligned}$$

(c) The temperature distributions are found by plotting Eqs. 3.80 and 3.82 over the range  $0 \leq x \leq 40 \text{ mm}$ . Note, that for the adiabatic tip case, the tip temperature is nearly equal to the

Continued...

### PROBLEM 3.140 (Cont.)

ambient temperature. For the cooled tip, the temperature distribution is anti-symmetric about  $x = \frac{1}{2} L$ . For the cooled tip case and  $h = 0$ , the temperature distribution in the fin would be linear, corresponding to one-dimensional conduction in the fin. <

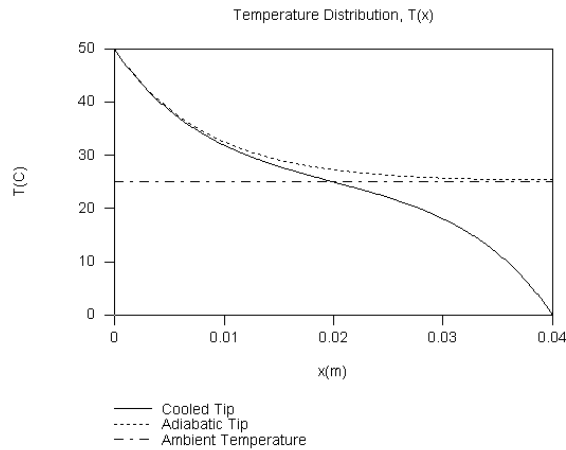

(d) The fin heat rate distributions are shown below. For adiabatic tip and  $h = 0$ ,  $q_f = 0$ . For the case of the cooled tip and negligible convection, the fin heat rate is

$$q_f = kA_c(T(x=L) - T_b) / L = (140 \text{ W/m}^2 \cdot \text{K} \times \pi \times (2 \times 10^{-3} \text{ m})^2 / 4) \times ((0 - 50)^\circ\text{C} / 40 \times 10^{-3} \text{ m}) = 0.549 \text{ W}.$$

As the convection coefficient increases, the temperatures at  $x = \frac{1}{2} L$  approach  $T(x = \frac{1}{2} L) = 25^\circ\text{C}$  for both the adiabatic and cooled tip cases, resulting in nearly the same fin heat transfer rates. Equations 3.76 and 3.78 would yield the same result for the cooled tip case since heat lost by convection over the range  $0 \leq x \leq 20 \text{ mm}$  would be exactly offset by the heat gain by convection over the range  $20 \text{ mm} \leq x \leq 40 \text{ mm}$ , and heat loss at  $x = L$  by conduction is equal to heat gain at  $x = 0$  by conduction. <

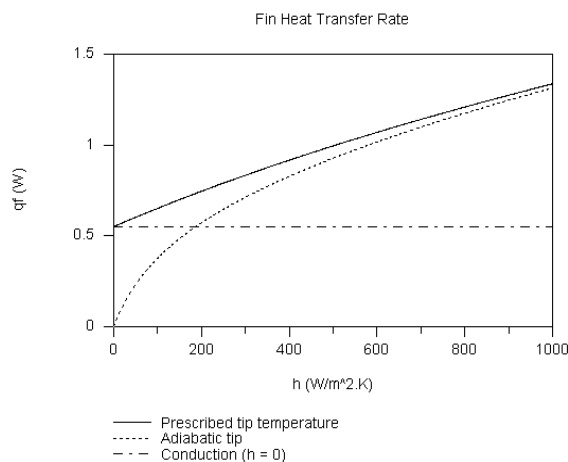

### PROBLEM 3.141

**KNOWN:** Base temperature, ambient fluid conditions, and temperatures at a prescribed distance from the base for two long rods, with one of known thermal conductivity.

**FIND:** Thermal conductivity of other rod.

**SCHEMATIC:**

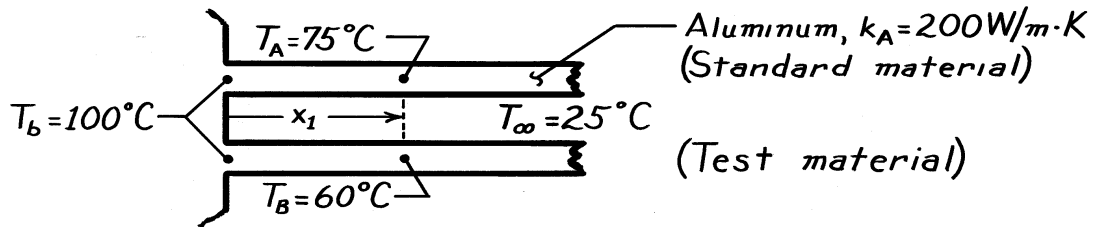

**ASSUMPTIONS:** (1) Steady-state, (2) One-dimensional conduction along rods, (3) Constant properties, (4) Negligible radiation, (5) Negligible contact resistance at base, (6) Infinitely long rods, (7) Rods are identical except for their thermal conductivity.

**ANALYSIS:** With the assumption of infinitely long rods, the temperature distribution is

$$\frac{\theta}{\theta_b} = \frac{T - T_\infty}{T_b - T_\infty} = e^{-mx}$$

or

$$\ln \frac{T - T_\infty}{T_b - T_\infty} = -mx = \left[ \frac{hP}{kA} \right]^{1/2} x$$

Hence, for the two rods,

$$\frac{\ln \left[ \frac{T_A - T_\infty}{T_b - T_\infty} \right]}{\ln \left[ \frac{T_B - T_\infty}{T_b - T_\infty} \right]} = \left[ \frac{k_B}{k_A} \right]^{1/2}$$

$$k_B^{1/2} = k_A^{1/2} \frac{\ln \left[ \frac{T_A - T_\infty}{T_b - T_\infty} \right]}{\ln \left[ \frac{T_B - T_\infty}{T_b - T_\infty} \right]} = (200)^{1/2} \frac{\ln \frac{75 - 25}{100 - 25}}{\ln \frac{60 - 25}{100 - 25}} = 7.524$$

$$k_B = 56.6 \text{ W/m} \cdot \text{K.}$$

<

**COMMENTS:** Providing conditions for the two rods may be maintained nearly identical, the above method provides a convenient means of measuring the thermal conductivity of solids.

### PROBLEM 3.142

**KNOWN:** Arrangement of fins between parallel plates. Temperature and convection coefficient of air flow in finned passages. Maximum allowable plate temperatures.

**FIND:** (a) Expressions relating fin heat transfer rates to end temperatures, (b) Maximum power dissipation for each plate.

**SCHEMATIC:**

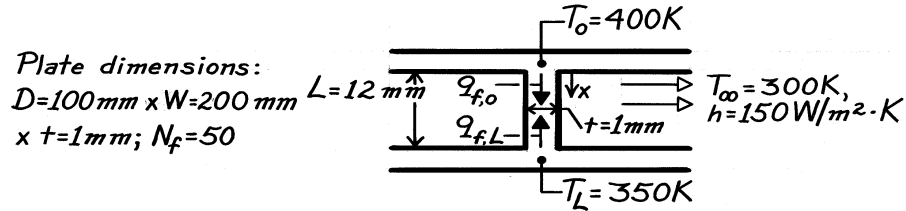

**ASSUMPTIONS:** (1) Steady-state conditions, (2) One-dimensional conduction in fins, (3) Constant properties, (4) Negligible radiation, (5) Uniform  $h$ , (6) Negligible variation in  $T_\infty$ , (7) Negligible contact resistance.

**PROPERTIES:** Table A.1, Aluminum (pure), 375 K:  $k = 240\text{ W/m}\cdot\text{K}$ .

**ANALYSIS:** (a) The general solution for the temperature distribution in a fin is

$$\theta(x) \equiv T(x) - T_\infty = C_1 e^{mx} + C_2 e^{-mx}$$

Boundary conditions:  $\theta(0) = \theta_o = T_o - T_\infty$ ,  $\theta(L) = \theta_L = T_L - T_\infty$ .

Hence  $\theta_o = C_1 + C_2$   $\theta_L = C_1 e^{mL} + C_2 e^{-mL}$

$$\theta_L = C_1 e^{mL} + (\theta_o - C_1) e^{-mL}$$

$$C_1 = \frac{\theta_L - \theta_o e^{-mL}}{e^{mL} - e^{-mL}} \quad C_2 = \theta_o - \frac{\theta_L - \theta_o e^{-mL}}{e^{mL} - e^{-mL}} = \frac{\theta_o e^{mL} - \theta_L}{e^{mL} - e^{-mL}}$$

Hence 
$$\theta(x) = \frac{\theta_L e^{mx} - \theta_o e^{m(x-L)} + \theta_o e^{m(L-x)} - \theta_L e^{-mx}}{e^{mL} - e^{-mL}}$$

$$\theta(x) = \frac{\theta_o \left[ e^{m(L-x)} - e^{-m(L-x)} \right] + \theta_L \left( e^{mx} - e^{-mx} \right)}{e^{mL} - e^{-mL}}$$

$$\theta(x) = \frac{\theta_o \sinh m(L-x) + \theta_L \sinh mx}{\sinh mL}$$

The fin heat transfer rate is then

$$q_f = -kA_c \frac{dT}{dx} = -kDt \left[ -\frac{\theta_o m}{\sinh mL} \cosh m(L-x) + \frac{\theta_L m}{\sinh mL} \cosh mx \right]$$

Hence 
$$q_{f,o} = kDt \left( \frac{\theta_o m}{\tanh mL} - \frac{\theta_L m}{\sinh mL} \right) <$$

$$q_{f,L} = kDt \left( \frac{\theta_o m}{\sinh mL} - \frac{\theta_L m}{\tanh mL} \right) <$$

Continued ...

**PROBLEM 3.142 (Cont.)**

$$(b) \quad m = \left( \frac{hP}{kA_c} \right)^{1/2} = \left( \frac{150 \text{ W/m}^2 \cdot \text{K} (2 \times 0.1 \text{ m} + 2 \times 0.001 \text{ m})}{240 \text{ W/m} \cdot \text{K} \times 0.1 \text{ m} \times 0.001 \text{ m}} \right)^{1/2} = 35.5 \text{ m}^{-1}$$

$$mL = 35.5 \text{ m}^{-1} \times 0.012 \text{ m} = 0.43$$

$$\sinh mL = 0.439 \quad \tanh mL = 0.401 \quad \theta_o = 100 \text{ K} \quad \theta_L = 50 \text{ K}$$

$$q_{f,o} = 240 \text{ W/m} \cdot \text{K} \times 0.1 \text{ m} \times 0.001 \text{ m} \left( \frac{100 \text{ K} \times 35.5 \text{ m}^{-1}}{0.401} - \frac{50 \text{ K} \times 35.5 \text{ m}^{-1}}{0.439} \right)$$

$$q_{f,o} = 115.4 \text{ W} \quad (\text{from the top plate})$$

$$q_{f,L} = 240 \text{ W/m} \cdot \text{K} \times 0.1 \text{ m} \times 0.001 \text{ m} \left( \frac{100 \text{ K} \times 35.5 \text{ m}^{-1}}{0.439} - \frac{50 \text{ K} \times 35.5 \text{ m}^{-1}}{0.401} \right)$$

$$q_{f,L} = 87.8 \text{ W}. \quad (\text{into the bottom plate})$$

Maximum power dissipations are therefore

$$q_{o,\max} = N_f q_{f,o} + (W - N_f t) Dh \theta_o$$

$$q_{o,\max} = 50 \times 115.4 \text{ W} + (0.200 - 50 \times 0.001) \text{ m} \times 0.1 \text{ m} \times 150 \text{ W/m}^2 \cdot \text{K} \times 100 \text{ K}$$

$$q_{o,\max} = 5770 \text{ W} + 225 \text{ W} = 5995 \text{ W} \quad <$$

$$q_{L,\max} = -N_f q_{f,L} + (W - N_f t) Dh \theta_o$$

$$q_{L,\max} = -50 \times 87.8 \text{ W} + (0.200 - 50 \times 0.001) \text{ m} \times 0.1 \text{ m} \times 150 \text{ W/m}^2 \cdot \text{K} \times 50 \text{ K}$$

$$q_{L,\max} = -4390 \text{ W} + 112 \text{ W} = -4278 \text{ W}. \quad <$$

**COMMENTS:** (1) It is of interest to determine the air velocity needed to prevent excessive heating of the air as it passes between the plates. If the air temperature change is restricted to  $\Delta T_\infty = 5 \text{ K}$ , its flowrate must be

$$\dot{m}_{\text{air}} = \frac{q_{\text{tot}}}{c_p \Delta T_\infty} = \frac{1717 \text{ W}}{1007 \text{ J/kg} \cdot \text{K} \times 5 \text{ K}} = 0.34 \text{ kg/s}.$$

Its mean velocity is then

$$V_{\text{air}} = \frac{\dot{m}_{\text{air}}}{\rho_{\text{air}} A_c} = \frac{0.34 \text{ kg/s}}{1.16 \text{ kg/m}^3 \times 0.012 \text{ m} (0.2 - 50 \times 0.001) \text{ m}} = 163 \text{ m/s}.$$

Such a velocity would be impossible to maintain. To reduce it to a reasonable value, e.g. 10 m/s,  $A_c$  would have to be increased substantially by increasing  $W$  (and hence the space between fins) and by increasing  $L$ . The present configuration is impractical from the standpoint that 1717 W could not be transferred to air in such a small volume.

(2) A negative value of  $q_{L,\max}$  implies that the bottom plate must be cooled externally to maintain the plate at 350 K.

### PROBLEM 3.143

**KNOWN:** Conditions associated with an array of straight rectangular fins.

**FIND:** Thermal resistance of the array.

**SCHEMATIC:**

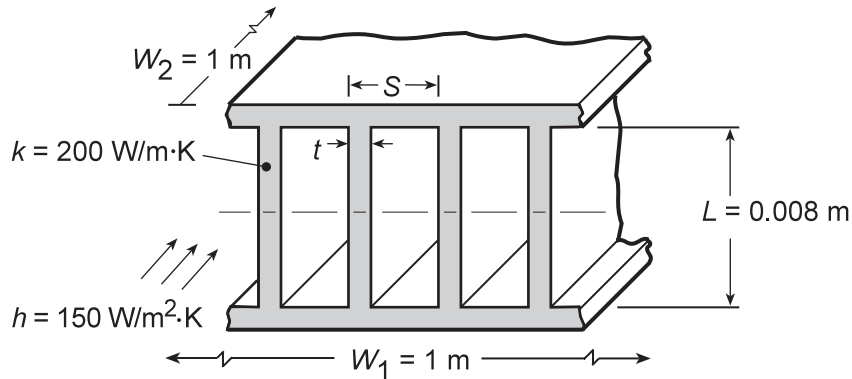

**ASSUMPTIONS:** (1) Constant properties, (2) Uniform convection coefficient, (3) Symmetry about midplane.

**ANALYSIS:** (a) Considering a one-half section of the array, the corresponding resistance is

$$R_{t,o} = (\eta_o h A_t)^{-1}$$

where  $A_t = N A_f + A_b$ . With  $S = 4 \text{ mm}$  and  $t = 1 \text{ mm}$ , it follows that  $N = W_1/S = 250$ ,  $A_f = 2(L/2)W_2 = 0.008 \text{ m}^2$ ,  $A_b = W_2(W_1 - Nt) = 0.75 \text{ m}^2$ , and  $A_t = 2.75 \text{ m}^2$ .

The overall surface efficiency is

$$\eta_o = 1 - \frac{N A_f}{A_t} (1 - \eta_f)$$

where the fin efficiency is

$$\eta_f = \frac{\tanh m(L/2)}{m(L/2)} \quad \text{and} \quad m = \left( \frac{hP}{kA_c} \right)^{1/2} = \left[ \frac{h(2t + 2W_2)}{ktW_2} \right]^{1/2} \approx \left( \frac{2h}{kt} \right)^{1/2} = 38.7 \text{ m}^{-1}$$

With  $m(L/2) = 0.155$ , it follows that  $\eta_f = 0.992$  and  $\eta_o = 0.994$ . Hence

$$R_{t,o} = \left( 0.994 \times 150 \text{ W/m}^2 \cdot \text{K} \times 2.75 \text{ m}^2 \right)^{-1} = 2.44 \times 10^{-3} \text{ K/W}$$

(b) The requirements that  $t \geq 0.5 \text{ mm}$  and  $(S - t) > 2 \text{ mm}$  are based on manufacturing and flow passage restriction constraints. Repeating the foregoing calculations for representative values of  $t$  and  $(S - t)$ , we obtain

S (mm)	N	t (mm)	$R_{t,o}$ (K/W)
2.5	400	0.5	0.00169
3	333	0.5	0.00193
3	333	1	0.00202
4	250	0.5	0.00234
4	250	2	0.00268
5	200	0.5	0.00269
5	200	3	0.00334

**COMMENTS:** Clearly, the thermal performance of the fin array improves ( $R_{t,o}$  decreases) with increasing  $N$ . Because  $\eta_f \approx 1$  for the entire range of conditions, there is a slight degradation in performance ( $R_{t,o}$  increases) with increasing  $t$  and fixed  $N$ . The reduced performance is associated with the reduction in surface area of the exposed base. Note that the overall thermal resistance for the entire fin array (top and bottom) is  $R_{t,o}/2 = 1.22 \times 10^{-2} \text{ K/W}$ .

### PROBLEM 3.144

**KNOWN:** Dimensions and maximum allowable temperature of an electronic chip. Thermal contact resistance between chip and heat sink. Dimensions and thermal conductivity of heat sink. Temperature and convection coefficient associated with air flow through the heat sink.

**FIND:** (a) Maximum allowable chip power for heat sink with prescribed number of fins, fin thickness, and fin pitch, and (b) Effect of fin thickness/number and convection coefficient on performance.

**SCHEMATIC:**

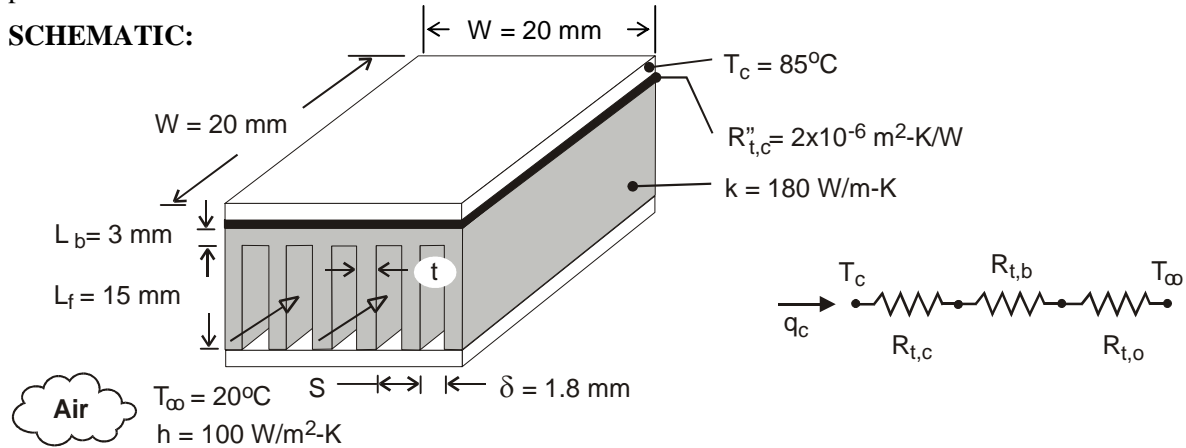

**ASSUMPTIONS:** (1) Steady-state, (2) One-dimensional heat transfer, (3) Isothermal chip, (4) Negligible heat transfer from top surface of chip, (5) Negligible temperature rise for air flow, (6) Uniform convection coefficient associated with air flow through channels and over outer surfaces of heat sink, (7) Negligible radiation.

**ANALYSIS:** (a) From the thermal circuit,

$$q_c = \frac{T_c - T_\infty}{R_{tot}} = \frac{T_c - T_\infty}{R_{t,c} + R_{t,b} + R_{t,o}}$$

where  $R_{t,c} = R''_{t,c} / W^2 = 2 \times 10^{-6} \text{ m}^2 \cdot \text{K} / \text{W} / (0.02 \text{ m})^2 = 0.005 \text{ K} / \text{W}$  and  $R_{t,b} = L_b / k (W^2) = 0.003 \text{ m} / 180 \text{ W} / \text{m} \cdot \text{K} (0.02 \text{ m})^2 = 0.042 \text{ K} / \text{W}$ . From Eqs. (3.108), (3.107), and (3.104)

$$R_{t,o} = \frac{1}{\eta_o h A_t}, \quad \eta_o = 1 - \frac{N A_f}{A_t} (1 - \eta_f), \quad A_t = N A_f + A_b$$

where  $A_f = 2 W L_f = 2 \times 0.02 \text{ m} \times 0.015 \text{ m} = 6 \times 10^{-4} \text{ m}^2$  and  $A_b = W^2 - N(tW) = (0.02 \text{ m})^2 - 11(0.182 \times 10^{-3} \text{ m} \times 0.02 \text{ m}) = 3.6 \times 10^{-4} \text{ m}^2$ . With  $m L_f = (2h/kt)^{1/2} L_f = (200 \text{ W} / \text{m}^2 \cdot \text{K} / 180 \text{ W} / \text{m} \cdot \text{K} \times 0.182 \times 10^{-3} \text{ m})^{1/2} (0.015 \text{ m}) = 1.17$ ,  $\tanh m L_f = 0.824$  and Eq. (3.92) yields

$$\eta_f = \frac{\tanh m L_f}{m L_f} = \frac{0.824}{1.17} = 0.704$$

It follows that  $A_t = 6.96 \times 10^{-3} \text{ m}^2$ ,  $\eta_o = 0.719$ ,  $R_{t,o} = 2.00 \text{ K} / \text{W}$ , and

$$q_c = \frac{(85 - 20)^\circ \text{C}}{(0.005 + 0.042 + 2.00) \text{ K} / \text{W}} = 31.8 \text{ W} \quad <$$

(b) The following results are obtained from parametric calculations performed to explore the effect of decreasing the number of fins and increasing the fin thickness.

Continued ...



**PROBLEM 3.144 (Cont.)**

N	t(mm)	$\eta_f$	$R_{t,o}$ (K/W)	$q_c$ (W)	$A_t$ (m <sup>2</sup> )
6	1.833	0.957	2.76	23.2	0.00378
7	1.314	0.941	2.40	26.6	0.00442
8	0.925	0.919	2.15	29.7	0.00505
9	0.622	0.885	1.97	32.2	0.00569
10	0.380	0.826	1.89	33.5	0.00632
11	0.182	0.704	2.00	31.8	0.00696

Although  $\eta_f$  (and  $\eta_o$ ) increases with decreasing N (increasing t), there is a reduction in  $A_t$  which yields a minimum in  $R_{t,o}$ , and hence a maximum value of  $q_c$ , for N = 10. For N = 11, the effect of h on the performance of the heat sink is shown below.

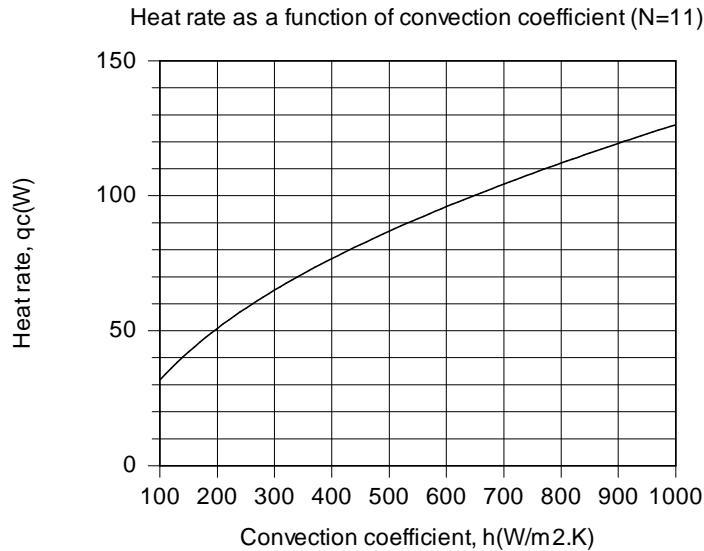

With increasing h from 100 to 1000 W/m<sup>2</sup>·K,  $R_{t,o}$  decreases from 2.00 to 0.47 K/W, despite a decrease in  $\eta_f$  (and  $\eta_o$ ) from 0.704 (0.719) to 0.269 (0.309). The corresponding increase in  $q_c$  is significant.

**COMMENTS:** (1) The heat sink significantly increases the allowable heat dissipation. If it were not used and heat was simply transferred by convection from the surface of the chip with  $h = 100$  W/m<sup>2</sup>·K,  $R_{tot} = 2.05$  K/W from Part (a) would be replaced by  $R_{cnv} = 1/hW^2 = 25$  K/W, yielding  $q_c = 2.60$  W. (2) The air temperature will increase as it flows through the heat sink. Therefore the required air velocity will be greater than determined here. See Problem 11.89.

### PROBLEM 3.145

**KNOWN:** Dimensions of electronics package and finned nano-heat sink. Temperature and heat transfer coefficient of coolant.

**FIND:** Maximum heat rate to maintain temperature below 85°C for finned and un-finned packages.

**SCHEMATIC:**

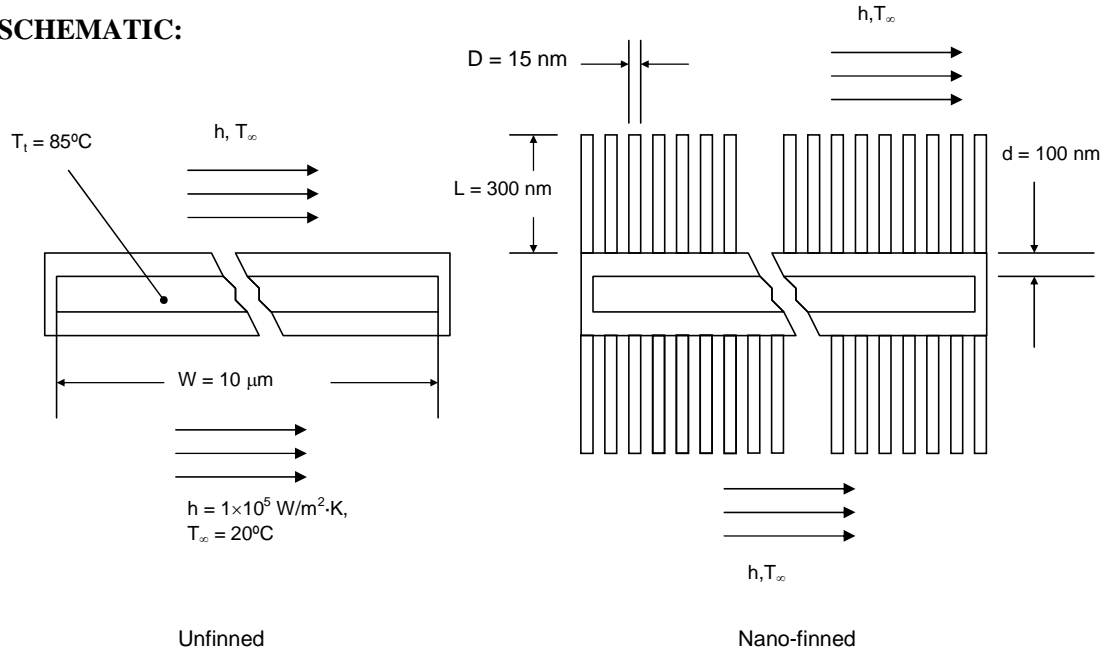

**ASSUMPTIONS:** (1) Steady-state, (2) Negligible temperature variation across fin thickness, (3) Constant properties, (4) Uniform heat transfer coefficient, (5) Negligible contact resistance, (6) Negligible heat loss from edges of package.

**PROPERTIES:** Table A.2, Silicon carbide ( $T \approx 300$  K):  $k = 490$  W/m·K.

**ANALYSIS:** (a) The thermal circuit for the un-finned package is

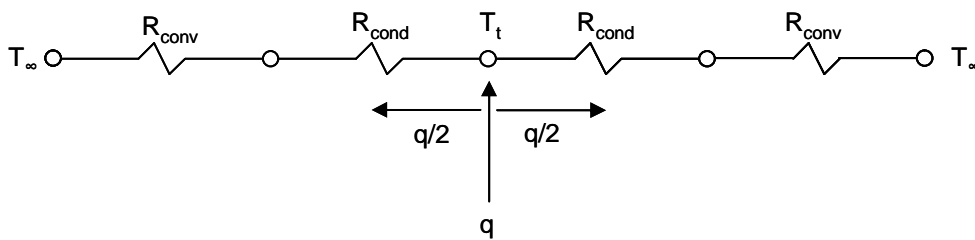

$$\text{where } R_{\text{cond}} = \frac{d}{kA} = \frac{100 \times 10^{-9} \text{ m}}{490 \text{ W/m} \cdot \text{K} \times (10 \times 10^{-6} \text{ m})^2} = 2.04 \text{ K/W}$$

$$R_{\text{conv}} = \frac{1}{hA} = \frac{1}{10^5 \text{ W/m}^2 \cdot \text{K} \times (10 \times 10^{-6} \text{ m})^2} = 1 \times 10^5 \text{ K/W}$$

$$\text{Thus } q = 2 \frac{(T_t - T_\infty)}{R_{\text{cond}} + R_{\text{conv}}} = 2 \frac{(85^\circ\text{C} - 20^\circ\text{C})}{(2.04 + 10^5) \text{ K/W}} = 1.30 \times 10^{-3} \text{ W}$$

<

Continued...

### PROBLEM 3.145 (Cont.)

For the finned nano-heat sink, the convection resistance is replaced by a fin array thermal resistance:

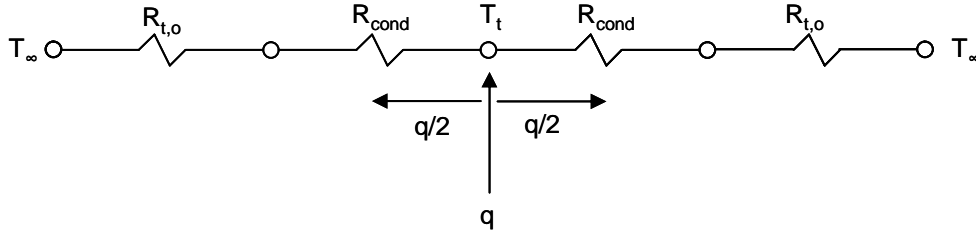

From Equations 3.108, 3.107, and 3.104

$$R_{t,o} = \frac{1}{\eta_o h A_t}, \quad \eta_o = 1 - \frac{N A_f}{A_t} (1 - \eta_f), \quad A_t = N A_f + A_b$$

where  $A_f = \pi D L_c = \pi D (L + D/4) = \pi \times 15 \times 10^{-9} \text{ m} \times (300 + 15/4) \times 10^{-9} \text{ m} = 1.43 \times 10^{-14} \text{ m}^2$ ,

$A_b = W^2 - N \pi D^2/4 = (10 \times 10^{-6} \text{ m})^2 - 40,000 \times \pi \times (15 \times 10^{-9} \text{ m})^2/4 = 9.29 \times 10^{-11} \text{ m}^2$ , and

$A_t = 40,000 \times 1.43 \times 10^{-14} \text{ m}^2 + 9.29 \times 10^{-11} \text{ m}^2 = 6.65 \times 10^{-10} \text{ m}^2$ . Then with

$m L_c = (4h/kD)^{1/2} L_c = (4 \times 10^5 \text{ W/m}^2 \cdot \text{K} / 490 \text{ W/m} \cdot \text{K} \times 15 \times 10^{-9} \text{ m})^{1/2} \times 304 \times 10^{-9} \text{ m} = 7.09 \times 10^{-2}$ ,

$$\eta_f = \frac{\tanh(m L_c)}{m L_c} = \frac{\tanh(7.09 \times 10^{-2})}{7.09 \times 10^{-2}} = 0.998$$

It follows that

$$\eta_o = 1 - \frac{40,000 \times 1.43 \times 10^{-14} \text{ m}^2}{6.65 \times 10^{-10} \text{ m}^2} (1 - 0.998) = 0.999$$

and

$$R_{t,o} = \frac{1}{0.999 \times 10^5 \text{ W/m}^2 \cdot \text{K} \times 6.65 \times 10^{-10} \text{ m}^2} = 1.50 \times 10^4 \text{ K/W}$$

Therefore

$$q = 2 \frac{(T_t - T_\infty)}{R_{\text{cond}} + R_{t,o}} = 2 \frac{(85^\circ\text{C} - 20^\circ\text{C})}{2.04 \text{ K/W} + 1.50 \times 10^4 \text{ K/W}} = 8.64 \times 10^{-3} \text{ W} <$$

**COMMENTS:** (1) The conduction resistance of the silicon carbide sheets is negligible. (2) The fins increase the allowable heat rate significantly. (3) We have neglected the contact resistance between the electronics and the silicon carbide sheets. If it dominates, the fins will not be effective in increasing the allowable heat rate. Little is known about contact resistance at the nanoscale.

### PROBLEM 3.146

**KNOWN:** Geometry and cooling arrangement for a chip-circuit board arrangement. Maximum chip temperature.

**FIND:** (a) Equivalent thermal circuit, (b) Maximum chip heat rate.

**SCHEMATIC:**

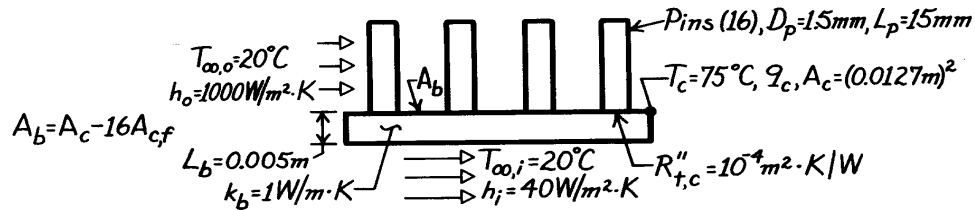

**ASSUMPTIONS:** (1) Steady-state conditions, (2) One-dimensional heat transfer in chip-board assembly, (3) Negligible pin-chip contact resistance, (4) Constant properties, (5) Negligible chip thermal resistance, (6) Uniform chip temperature.

**PROPERTIES:** Table A.1, Copper (300 K):  $k \approx 400$  W/m·K.

**ANALYSIS:** (a) The thermal circuit is

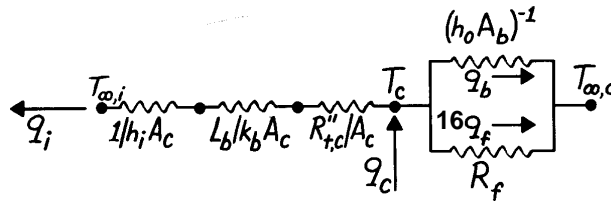

$$R_f = \frac{\theta_b}{16q_f} = \frac{\cosh mL + (h_o/mk) \sinh mL}{16(h_o P k A_{c,f})^{1/2} [\sinh mL + (h_o/mk) \cosh mL]}$$

(b) The maximum chip heat rate is

$$q_c = 16q_f + q_b + q_i.$$

Evaluate these parameters

$$m = \left( \frac{h_o P}{k A_{c,f}} \right)^{1/2} = \left( \frac{4h_o}{k D_p} \right)^{1/2} = \left( \frac{4 \times 1000 \text{ W/m}^2 \cdot \text{K}}{400 \text{ W/m} \cdot \text{K} \times 0.0015 \text{ m}} \right)^{1/2} = 81.7 \text{ m}^{-1}$$

$$mL = (81.7 \text{ m}^{-1} \times 0.015 \text{ m}) = 1.23, \quad \sinh mL = 1.57, \quad \cosh mL = 1.86$$

$$(h_o/mk) = \frac{1000 \text{ W/m}^2 \cdot \text{K}}{81.7 \text{ m}^{-1} \times 400 \text{ W/m} \cdot \text{K}} = 0.0306$$

$$M = \left( h_o \pi D_p k \pi D_p^2 / 4 \right)^{1/2} \theta_b$$

$$M = \left[ 1000 \text{ W/m}^2 \cdot \text{K} \left( \pi^2 / 4 \right) (0.0015 \text{ m})^3 400 \text{ W/m} \cdot \text{K} \right]^{1/2} (55^\circ \text{C}) = 3.17 \text{ W}.$$

Continued ...

**PROBLEM 3.146 (Cont.)**

The fin heat rate is

$$q_f = M \frac{\sinh mL + (h_o/mk) \cosh mL}{\cosh mL + (h_o/mk) \sinh mL} = 3.17 \text{ W} \frac{1.57 + 0.0306 \times 1.86}{1.86 + 0.0306 \times 1.57}$$

$$q_f = 2.703 \text{ W.}$$

The heat rate from the chip top by convection is

$$q_b = h_o A_b \theta_b = 1000 \text{ W/m}^2 \cdot \text{K} \left[ (0.0127 \text{ m})^2 - (16\pi/4)(0.0015 \text{ m})^2 \right] 55^\circ \text{C}$$

$$q_b = 7.32 \text{ W.}$$

The convection heat rate from the board is

$$q_i = \frac{T_c - T_{\infty,i}}{(1/h_i + R''_{t,c} + L_b/k_b)(1/A_c)} = \frac{(0.0127 \text{ m})^2 (55^\circ \text{C})}{(1/40 + 10^{-4} + 0.005/1) \text{ m}^2 \cdot \text{K/W}}$$

$$q_i = 0.29 \text{ W.}$$

Hence, the maximum chip heat rate is

$$q_c = [16(2.703) + 7.32 + 0.29] \text{ W} = [43.25 + 7.32 + 0.29] \text{ W}$$

$$q_c = 50.9 \text{ W.} \quad <$$

**COMMENTS:** (1) The fins are extremely effective in enhancing heat transfer from the chip (assuming negligible contact resistance). Their effectiveness is  $\varepsilon = q_f / (\pi D_p^2/4) h_o \theta_b = 2.703 \text{ W} / 0.097 \text{ W} = 27.8$

(2) Without the fins,  $q_c = 1000 \text{ W/m}^2 \cdot \text{K} (0.0127 \text{ m})^2 55^\circ \text{C} + 0.29 \text{ W} = 9.16 \text{ W}$ . Hence the fins provide for a  $(50.9 \text{ W} / 9.16 \text{ W}) \times 100\% = 555\%$  enhancement of heat transfer.

(3) With the fins, the chip heat flux is  $50.9 \text{ W} / (0.0127 \text{ m})^2$  or  $q_c'' = 3.16 \times 10^5 \text{ W/m}^2 = 31.6 \text{ W/cm}^2$ .

(4) If the infinite fin approximation is made,  $q_f = M = 3.17 \text{ W}$ , and the actual fin heat transfer is overestimated by 17%.

### PROBLEM 3.147

**KNOWN:** Geometry of a cast iron burner with and without fins. Room temperature, combustion temperature, heat transfer coefficient at the top burner surface, heat transfer coefficient at the bottom burner surface, emissivity of burner coating, thermal conductivity of cast iron.

**FIND:** Temperature of the top burner surface with and without fins.

**SCHEMATIC:**

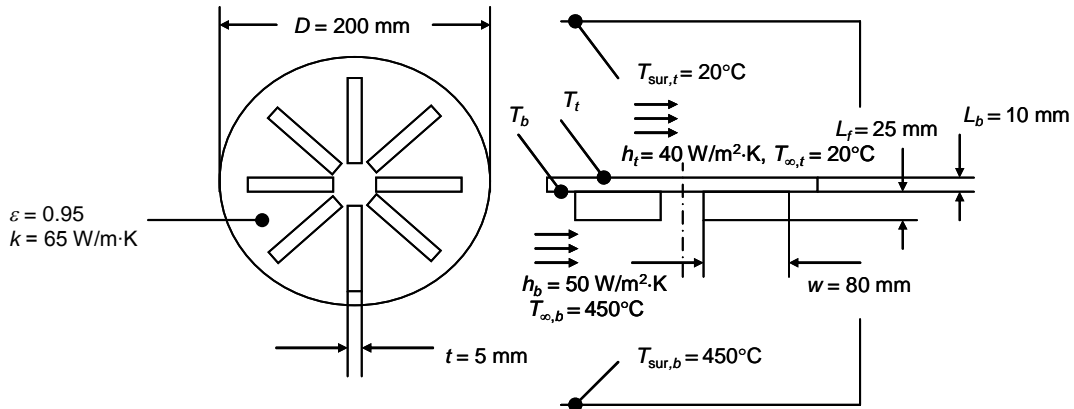

**ASSUMPTIONS:** (1) Steady-state, one-dimensional conditions, (2) Constant properties, (3) Convection from fin tip, (4) Large surroundings at top and bottom of burner.

**PROPERTIES:** Given, Cast iron:  $k = 65 \text{ W/m}\cdot\text{K}$ .

**ANALYSIS:** Evaluating the radiation heat transfer from the combustion products to the bottom of the burner as  $q_{\text{rad},b} = \varepsilon\sigma(\pi D^2/4)(T_{\text{sur},b}^4 - T_b^4)$ , the total heat transfer to the bottom of the burner's base is

$$q_b = N\eta_f h_b A_f (T_{\infty,b} - T_b) + h_b A_b (T_{\infty,b} - T_b) + A_t \varepsilon \sigma (T_{\text{sur},b}^4 - T_b^4) \quad (1)$$

where  $A_b = \pi D^2/4 - Ntw = \pi(0.200\text{m})^2/4 - 8 \times 0.005 \text{ m} \times 0.080 \text{ m} = 0.0282 \text{ m}^2$  is the base area without fins and  $A_t = \pi D^2/4 = \pi(0.2\text{m})^2/4 = 0.0314 \text{ m}^2$ . The total heat transfer from the top surface is

$$q_t = h_t A_t (T_t - T_{\infty,t}) + A_t \varepsilon \sigma (T_t^4 - T_{\text{sur},t}^4) \quad (2)$$

One-dimensional conduction through the base of the burner is

$$q_{\text{base}} = (kA_t / L_b)(T_b - T_t) \quad (3)$$

At steady state, the heat rates must be equal,

$$q_b = q_t; \quad q_{\text{base}} = q_t \quad (4, 5)$$

Continued...

### PROBLEM 3.147 (Cont.)

The fin efficiency may be evaluated using Table 3.5. The corrected fin length is  $L_c = L_f + t/2 = 25 \text{ mm} + 5 \text{ mm}/2 = 27.5 \text{ mm} = 27.5 \times 10^{-3} \text{ m}$ . The fin area is  $A_f = 2wL_c = 2 \times 0.080 \text{ m} \times 27.5 \times 10^{-3} \text{ m} = 0.0044 \text{ m}^2$ . The value of  $m$  is  $m = \sqrt{2h_b/kt} = \sqrt{2 \times 50 \text{ W/m}^2 \cdot \text{K} / 65 \text{ W/m} \cdot \text{K} \times 5 \times 10^{-3} \text{ m}} = 17.54 \text{ m}^{-1}$ . Finally, the fin efficiency is

$$\eta_f = \frac{\tanh mL_c}{mL_c} = \frac{\tanh(17.54 \text{ m}^{-1} \times 27.5 \times 10^{-3} \text{ m})}{17.54 \text{ m}^{-1} \times 27.5 \times 10^{-3} \text{ m}} = 0.93$$

Substituting values listed in the schematic, along with values of the various areas, the fin efficiency, and  $N = 8$  into Eqs. (1) through (5) and solving simultaneously yields

$$T_t = 601.7 \text{ K} = 328.7^\circ\text{C} \quad <$$

For a burner without fins, Eq. (1) is replaced by

$$q_b = h_b A_t (T_{\infty, b} - T_b) + A_t \varepsilon \sigma (T_{\text{sur}, b}^4 - T_b^4) \quad (6)$$

Substituting values and solving Eqs. (2) through (6) simultaneously yields

$$T_t = 570.5 \text{ K} = 297.5^\circ\text{C} \quad <$$

**COMMENTS:** (1) Adding fins to the bottom of the burner increases the steady-state top temperature by approximately 30 degrees Celsius. (2) The finned burner heat rate is  $q = 597.2 \text{ W}$ , while without fins the heat rate is  $q = 515.5 \text{ W}$ . Hence, the fins increase the heat rate available for cooking. (3) Radiation heat transfer is significant. With fins, radiation accounts for 35% of the heat rate at the top surface and 40% at the bottom surface. Without fins, radiation accounts for 32% at the top surface and 54% at the bottom surface. (4) In general, the treatment of radiation for finned surfaces, such as at the bottom surface of the finned burner is justified, as will be discussed in Chapter 13.

### PROBLEM 3.148

**KNOWN:** Geometry of pin fin array used as heat sink for a computer chip. Array convection and chip substrate conditions.

**FIND:** Effect of pin diameter, spacing and length on maximum allowable chip power dissipation.

**SCHEMATIC:**

**Physical System:**

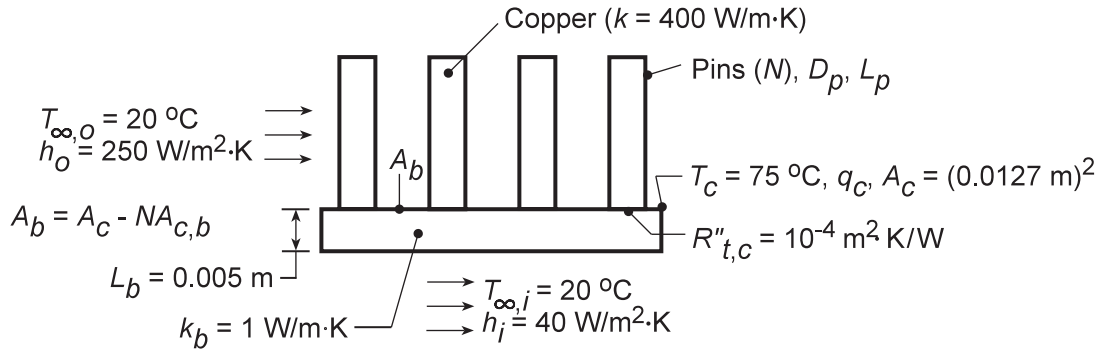

**Thermal Circuit:**

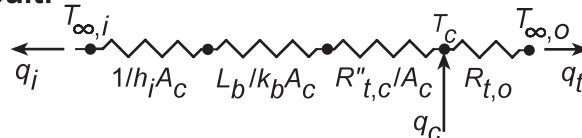

**ASSUMPTIONS:** (1) Steady-state conditions, (2) One-dimensional heat transfer in chip-board assembly, (3) Negligible pin-chip contact resistance, (4) Constant properties, (5) Negligible chip thermal resistance, (6) Uniform chip temperature.

**ANALYSIS:** The total power dissipation is  $q_c = q_i + q_t$ , where

$$q_i = \frac{T_c - T_{\infty,i}}{(1/h_i + R''_{t,c} + L_b/k_b)/A_c} = 0.3\text{ W}$$

and

$$q_t = \frac{T_c - T_{\infty,o}}{R_{t,o}}$$

The resistance of the pin array is

$$R_{t,o} = (\eta_o h_o A_t)^{-1}$$

where

$$\eta_o = 1 - \frac{NA_f}{A_t} (1 - \eta_f)$$

$$A_t = NA_f + A_b$$

$$A_f = \pi D_p L_c = \pi D_p (L_p + D_p/4)$$

Subject to the constraint that  $N^{1/2} D_p \leq 9\text{ mm}$ , the foregoing expressions may be used to compute  $q_t$  as a function of  $D_p$  for  $L_p = 15\text{ mm}$  and values of  $N = 16, 25$  and  $36$ . Using the *IHT Performance Calculation, Extended Surface Model* for the *Pin Fin Array*, we obtain

Continued...



### PROBLEM 3.148 (Cont.)

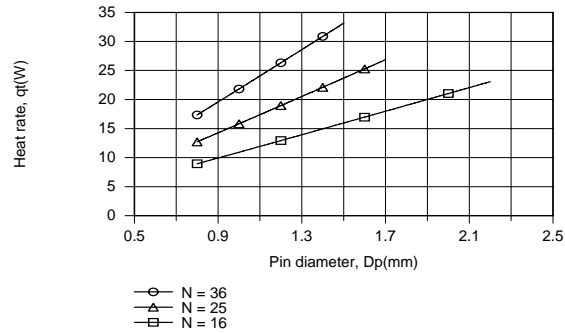

Clearly, it is desirable to maximize the number of pins and the pin diameter, so long as flow passages are not constricted to the point of requiring an excessive pressure drop to maintain the prescribed convection coefficient. The maximum heat rate for the fin array ( $q_t = 33.1$  W) corresponds to  $N = 36$  and  $D_p = 1.5$  mm. Further improvement could be obtained by using  $N = 49$  pins of diameter  $D_p = 1.286$  mm, which yield  $q_t = 37.7$  W.

Exploring the effect of  $L_p$  for  $N = 36$  and  $D_p = 1.5$  mm, we obtain

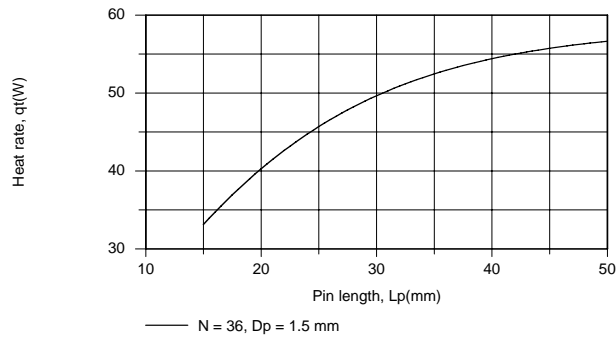

Clearly, there are benefits to increasing  $L_p$ , although the effect diminishes due to an attendant reduction in  $\eta_f$  (from  $\eta_f = 0.887$  for  $L_p = 15$  mm to  $\eta_f = 0.471$  for  $L_p = 50$  mm). Although a heat dissipation rate of  $q_t = 56.7$  W is obtained for  $L_p = 50$  mm, package volume constraints could preclude such a large fin length.

**COMMENTS:** By increasing  $N$ ,  $D_p$  and/or  $L_p$ , the total surface area of the array,  $A_t$ , is increased, thereby reducing the array thermal resistance,  $R_{t,o}$ . The effects of  $D_p$  and  $N$  are shown for  $L_p = 15$  mm.

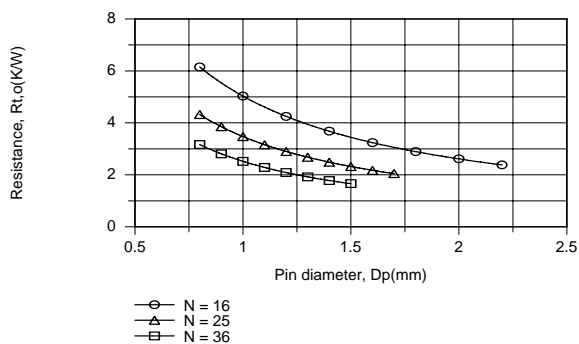

### PROBLEM 3.149

**KNOWN:** Diameter and internal fin configuration of copper tubes submerged in water. Tube wall temperature and temperature and convection coefficient of gas flow through the tube.

**FIND:** Rate of heat transfer per tube length.

**SCHEMATIC:**

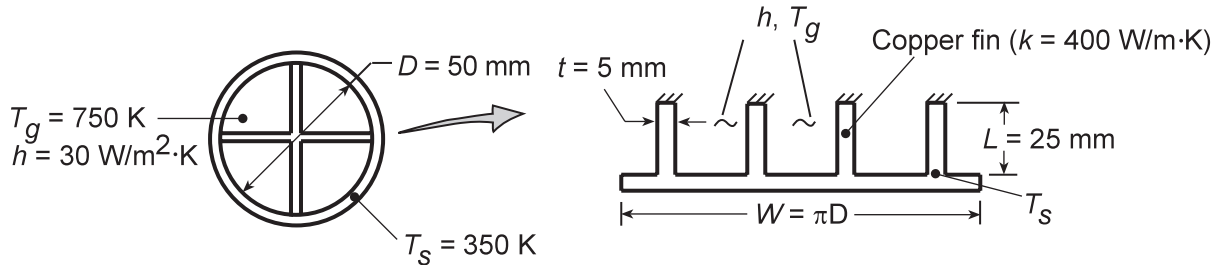

**ASSUMPTIONS:** (1) Steady-state, (2) One-dimensional fin conduction, (3) Constant properties, (4) Negligible radiation, (5) Uniform convection coefficient, (6) Tube wall may be unfolded and represented as a plane wall with four straight, rectangular fins, each with an adiabatic tip (since, by symmetry, there can be no heat flow along the fins where they cross).

**ANALYSIS:** The rate of heat transfer per unit tube length is:

$$q'_t = \eta_o h A'_t (T_g - T_s)$$

$$\eta_o = 1 - \frac{NA'_f}{A'_t} (1 - \eta_f)$$

$$NA'_f = 4 \times 2L = 8(0.025\text{m}) = 0.20\text{m}$$

$$A'_t = NA'_f + A'_b = 0.20\text{m} + (\pi D - 4t) = 0.20\text{m} + (\pi \times 0.05\text{m} - 4 \times 0.005\text{m}) = 0.337\text{m}$$

For an adiabatic fin tip,

$$\eta_f = \frac{q_f}{q_{\max}} = \frac{M \tanh mL}{h(2L \cdot 1)(T_g - T_s)}$$

$$M = [h^2(1m + t)k(1m \times t)]^{1/2} (T_g - T_s) \approx [30 \text{ W/m}^2 \cdot \text{K} (2\text{m}) 400 \text{ W/m} \cdot \text{K} (0.005\text{m}^2)]^{1/2} (400\text{K}) = 4382 \text{ W}$$

$$mL = \left\{ \frac{h^2(1m + t)}{k(1m \times t)} \right\}^{1/2} L \approx \left[ \frac{30 \text{ W/m}^2 \cdot \text{K} (2\text{m})}{400 \text{ W/m} \cdot \text{K} (0.005\text{m}^2)} \right]^{1/2} 0.025\text{m} = 0.137$$

Hence,  $\tanh mL = 0.136$ , and

$$\eta_f = \frac{4382 \text{ W} (0.136)}{30 \text{ W/m}^2 \cdot \text{K} (0.05\text{m}^2) (400\text{K})} = \frac{595 \text{ W}}{600 \text{ W}} = 0.992$$

$$\eta_o = 1 - \frac{0.20}{0.337} (1 - 0.992) = 0.995$$

$$q'_t = 0.995 (30 \text{ W/m}^2 \cdot \text{K}) 0.337\text{m} (400\text{K}) = 4025 \text{ W/m}$$

**COMMENTS:** Alternatively,  $q'_t = 4q'_f + h(A'_t - A'_f)(T_g - T_s)$ . Hence,  $q' = 4(595 \text{ W/m}) + 30 \text{ W/m}^2 \cdot \text{K} (0.137\text{m})(400 \text{ K}) = (2380 + 1644) \text{ W/m} = 4024 \text{ W/m}$ .

### PROBLEM 3.150

**KNOWN:** Copper heat sink dimensions and convection conditions.

**FIND:** (a) Maximum allowable heat dissipation for a prescribed chip temperature and interfacial chip/heat-sink contact resistance, (b) Effect of fin length and width on heat dissipation.

**SCHEMATIC:**

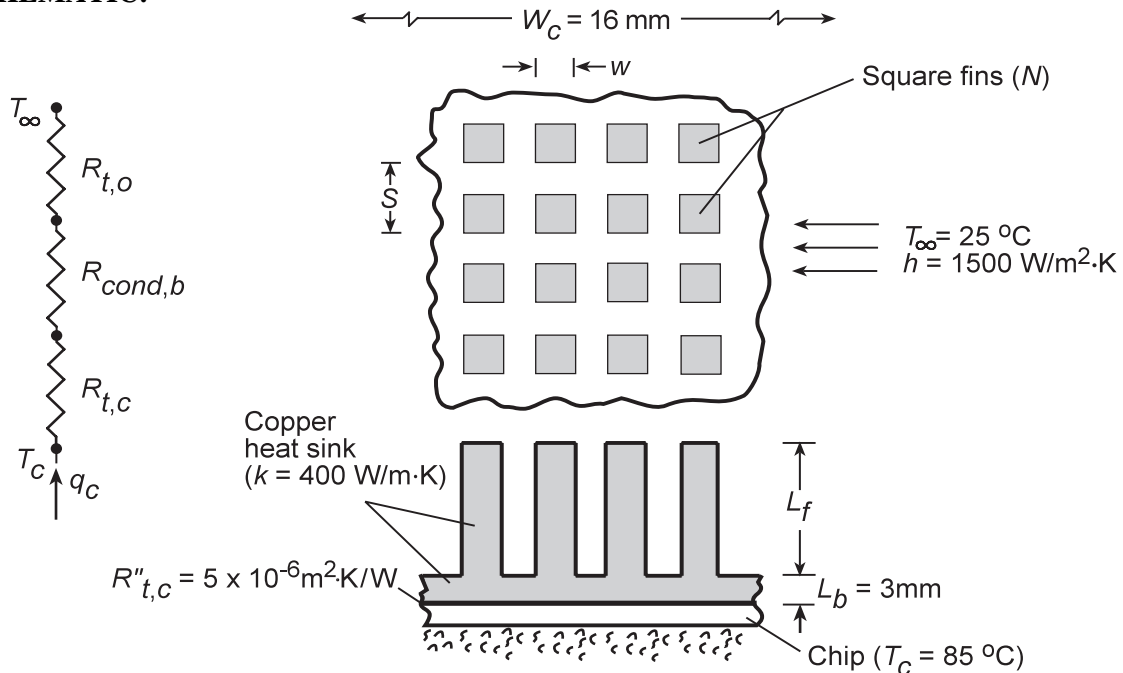

**ASSUMPTIONS:** (1) Steady-state conditions, (2) One-dimensional heat transfer in chip-heat sink assembly, (3) Constant  $k$ , (4) Negligible chip thermal resistance, (5) Negligible heat transfer from back of chip, (6) Uniform chip temperature.

**ANALYSIS:** (a) For the prescribed system, the chip power dissipation may be expressed as

$$q_c = \frac{T_c - T_\infty}{R_{t,c} + R_{\text{cond},b} + R_{t,o}}$$

where  $R_{t,c} = \frac{R''_{t,c}}{W_c^2} = \frac{5 \times 10^{-6} \text{ m}^2 \cdot \text{K}/\text{W}}{(0.016 \text{ m})^2} = 0.0195 \text{ K}/\text{W}$

$$R_{\text{cond},b} = \frac{L_b}{kW_c^2} = \frac{0.003 \text{ m}}{400 \text{ W}/\text{m} \cdot \text{K} (0.016 \text{ m})^2} = 0.0293 \text{ K}/\text{W}$$

The thermal resistance of the fin array is

$$R_{t,o} = (\eta_o h A_t)^{-1}$$

where  $\eta_o = 1 - \frac{N A_f}{A_t} (1 - \eta_f)$

and  $A_t = N A_f + A_b = N(4wL_c) + (W_c^2 - Nw^2)$

Continued...

### PROBLEM 3.150 (Cont.)

With  $w = 0.25$  mm,  $S = 0.50$  mm,  $L_f = 6$  mm,  $N = 1024$ , and  $L_c \approx L_f + w/4 = 6.063 \times 10^{-3}$  m, it follows that  $A_f = 6.06 \times 10^{-6}$  m<sup>2</sup> and  $A_t = 6.40 \times 10^{-3}$  m<sup>2</sup>. The fin efficiency is

$$\eta_f = \frac{\tanh mL_c}{mL_c}$$

where  $m = (hP/kA_c)^{1/2} = (4h/kw)^{1/2} = 245$  m<sup>-1</sup> and  $mL_c = 1.49$ . It follows that  $\eta_f = 0.608$  and  $\eta_o = 0.619$ , in which case

$$R_{t,o} = \left( 0.619 \times 1500 \text{ W/m}^2 \cdot \text{K} \times 6.40 \times 10^{-3} \text{ m}^2 \right) = 0.168 \text{ K/W}$$

and the maximum allowable heat dissipation is

$$q_c = \frac{(85 - 25)^\circ \text{C}}{(0.0195 + 0.0293 + 0.168) \text{ K/W}} = 276 \text{ W}$$

(b) The IHT *Performance Calculation, Extended Surface Model* for the *Pin Fin Array* has been used to determine  $q_c$  as a function of  $L_f$  for four different cases, each of which is characterized by the closest allowable fin spacing of  $(S - w) = 0.25$  mm.

Case	w (mm)	S (mm)	N
A	0.25	0.50	1024
B	0.35	0.60	711
C	0.45	0.70	522
D	0.55	0.80	400

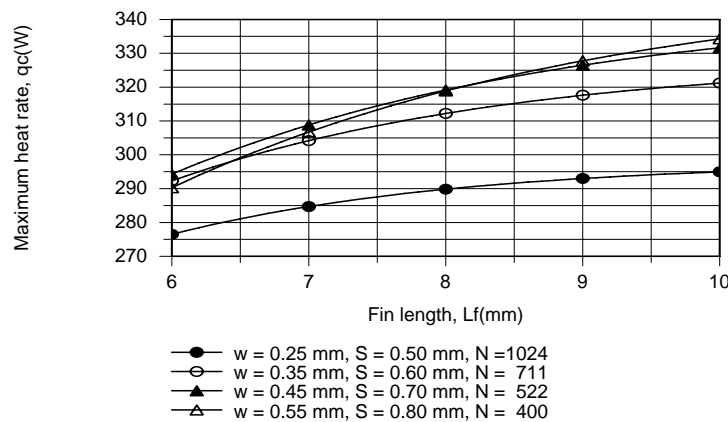

With increasing  $w$  and hence decreasing  $N$ , there is a reduction in the total area  $A_t$  associated with heat transfer from the fin array. However, for Cases A through C, the reduction in  $A_t$  is more than balanced by an increase in  $\eta_f$  (and  $\eta_o$ ), causing a reduction in  $R_{t,o}$  and hence an increase in  $q_c$ . As the fin efficiency approaches its limiting value of  $\eta_f = 1$ , reductions in  $A_t$  due to increasing  $w$  are no longer balanced by increases in  $\eta_f$ , and  $q_c$  begins to decrease. Hence there is an optimum value of  $w$ , which depends on  $L_f$ . For the conditions of this problem,  $L_f = 10$  mm and  $w = 0.55$  mm provide the largest heat dissipation.

### Problem 3.151

**KNOWN:** Two finned heat sinks, Designs A and B, prescribed by the number of fins in the array,  $N$ , fin dimensions of square cross-section,  $w$ , and length,  $L$ , with different convection coefficients,  $h$ .

**FIND:** Determine which fin arrangement is superior. Calculate the heat rate,  $q_f$ , efficiency,  $\eta_f$ , and effectiveness,  $\varepsilon_f$ , of a single fin, as well as, the total heat rate,  $q_t$ , and overall efficiency,  $\eta_o$ , of the array. Also, compare the total heat rates per unit volume.

**SCHEMATIC:**

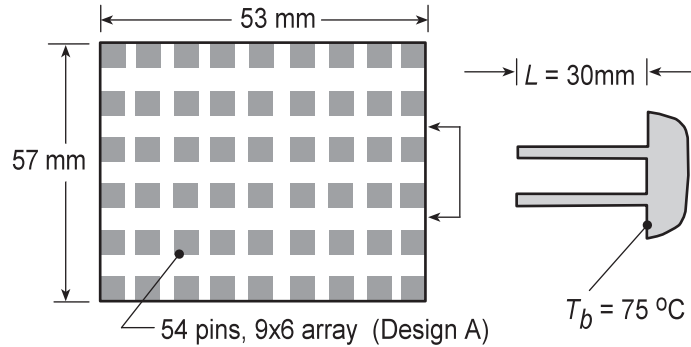

Design	Fin dimensions		Number of fins	Convection coefficient ( $W/m^2 \cdot K$ )
	Cross section $w \times w$ (mm)	Length $L$ (mm)		
A	3 x 3	30	6 x 9	125
B	1 x 1	7	14 x 17	375

**ASSUMPTIONS:** (1) Steady-state conditions, (2) One-dimensional conduction in fins, (3) Convection coefficient is uniform over fin and prime surfaces, (4) Fin tips experience convection, and (5) Constant properties.

**ANALYSIS:** Following the treatment of Section 3.6.5, the overall efficiency of the array, Eq. (3.103), is

$$\eta_o = \frac{q_t}{q_{\max}} = \frac{q_t}{hA_t\theta_b} \quad (1)$$

where  $A_t$  is the total surface area, the sum of the exposed portion of the base (prime area) plus the fin surfaces, Eq. 3.104,

$$A_t = N \cdot A_f + A_b \quad (2)$$

where the surface area of a single fin and the prime area are

$$A_f = 4(L \times w) + w^2 \quad (3)$$

$$A_b = b_1 \times b_2 - N \cdot A_c \quad (4)$$

Combining Eqs. (1) and (2), the total heat rate for the array is

$$q_t = N\eta_f hA_f\theta_b + hA_b\theta_b \quad (5)$$

where  $\eta_f$  is the efficiency of a single fin. From Table 3.4, Case A, for the tip condition with convection, the single fin efficiency based upon Eq. 3.91,

$$\eta_f = \frac{q_f}{hA_f\theta_b} \quad (6)$$

Continued...

### PROBLEM 3.151 (Cont.)

where

$$q_f = M \frac{\sinh(mL) + (h/mk) \cosh(mL)}{\cosh(mL) + (h/mk) \sinh(mL)} \quad (7)$$

$$M = (hPkA_c)^{1/2} \theta_b \quad m = (hP/kA_c)^{1/2} \quad P = 4w \quad A_c = w^2 \quad (8,9,10)$$

The single fin effectiveness, from Eq. 3.86,

$$\varepsilon_f = \frac{q_f}{hA_c\theta_b} \quad (11)$$

Additionally, we want to compare the performance of the designs with respect to the array volume,

$$q_f''' = q_t / \nabla = q_t / (b_1 \cdot b_2 \cdot L) \quad (12)$$

The above analysis was organized for easy treatment with equation-solving software. Solving Eqs. (1) through (11) simultaneously with appropriate numerical values, the results are tabulated below.

Design	$q_t$ (W)	$q_f$ (W)	$\eta_o$	$\eta_f$	$\varepsilon_f$	$q_f'''$ (W/m <sup>3</sup> )
A	113	1.80	0.804	0.779	31.9	$1.25 \times 10^6$
B	165	0.475	0.909	0.873	25.3	$7.81 \times 10^6$

**COMMENTS:** (1) Both designs have good efficiencies and effectiveness. Clearly, Design B is superior because the heat rate is nearly 50% larger than Design A for the same board footprint. Further, the space requirement for Design B is four times less ( $\nabla = 2.12 \times 10^{-5}$  vs.  $9.06 \times 10^{-5}$  m<sup>3</sup>) and the heat rate per unit volume is 6 times greater.

(2) Design A features 54 fins compared to 238 fins for Design B. Also very significant to the performance comparison is the magnitude of the convection coefficient which is 3 times larger for Design B. Estimating convection coefficients for fin arrays (and tube banks) is discussed in Chapter 7.6. Of concern is how the upstream fins alter the flow past the downstream fins and whether the convection coefficient is uniform over the array.

(3) The *IHT Extended Surfaces Model*, for a *Rectangular Pin Fin Array* could have been used to solve this problem.

### PROBLEM 3.152

**KNOWN:** Dimensions of a fin array and dust layer. Aluminum and dust thermal conductivities. Base temperature. Air temperature and heat transfer coefficient.

**FIND:** Allowable heat rate for dust layer thickness in the range of  $0 \leq L_d \leq 5 \text{ mm}$ .

**SCHEMATIC:**

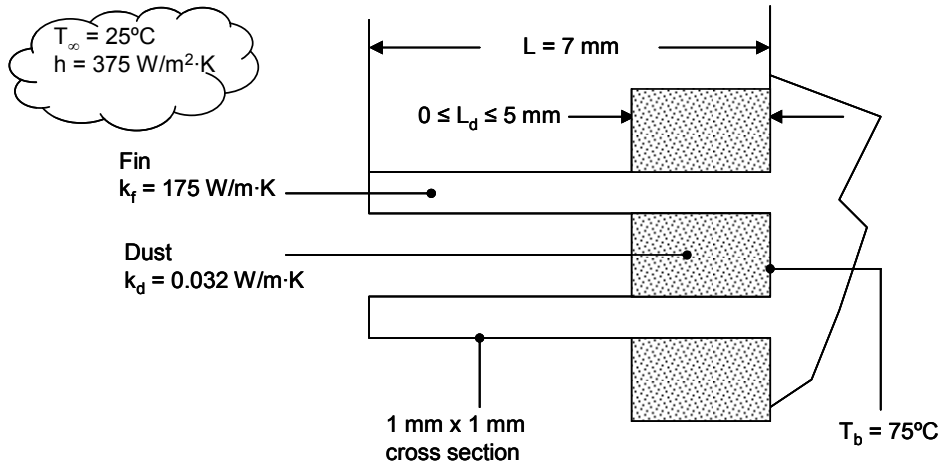

**ASSUMPTIONS:** (1) Steady-state, (2) Negligible temperature variation across fin thickness, (3) Constant properties, (4) Uniform heat transfer coefficient, including over fin tips.

**ANALYSIS:** There are two heat transfer paths, one through the dust and into the air, and the other through the fin. The thermal circuit is

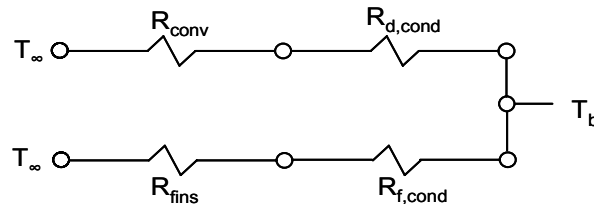

The thermal resistances are given by

$$R_{\text{d,cond}} = \frac{L_d}{k_d A_d} = \frac{L_d}{k_d (A_p - N A_c)}$$

where  $A_p = 53 \times 10^{-3} \text{ m} \times 57 \times 10^{-3} \text{ m} = 3.02 \times 10^{-3} \text{ m}^2$ ,  $N = 14 \times 17 = 238$  and  $A_c = w^2 = 10^{-6} \text{ m}^2$ .

$$R_{\text{conv}} = \frac{1}{h A_d}, \quad R_{\text{f,cond}} = \frac{L_d}{k_f N A_c} \quad \text{and} \quad R_{\text{fins}} = \frac{R_{\text{t,f}}}{N}$$

where from Equation 3.88

$$R_{\text{t,f}} = \frac{\theta_b}{q_f}$$

where  $q_f$  is given by Equation 3.77,

$$R_{\text{t,f}} = \frac{\cosh(m L_f) + (h / m k_f) \sinh(m L_f)}{\sqrt{4 h w^3 k} (\sinh(m L_f) + (h / m k_f) \cosh(m L_f))}$$

Continued...

### PROBLEM 3.152 (Cont.)

Here,  $m = (4h / k_f w)^{1/2} = (4 \times 375 \text{ W/m}^2 \cdot \text{K} / 175 \text{ W/m} \cdot \text{K} \times 10^{-3} \text{ m})^{1/2} = 92.6 \text{ m}^{-1}$

and  $L_f = L - L_d$ .

Finally,

$$q = q_{\text{dust}} + q_{\text{fin}}$$

$$= \frac{T_b - T_\infty}{R_{\text{d,cond}} + R_{\text{conv}}} + \frac{T_b - T_\infty}{R_{\text{f,cond}} + R_{\text{fins}}}$$

Performing the calculation for a dust layer thickness of  $L_d = 5 \text{ mm}$  yields

$$R_{\text{d,cond}} = 56.1 \text{ K/W}$$

$$R_{\text{conv}} = 0.958 \text{ K/W}$$

$$R_{\text{f,cond}} = 0.120 \text{ K/W}$$

$$R_{\text{t,f}} = 301 \text{ K/W}, \quad R_{\text{fins}} = 1.26 \text{ K/W}$$

$$q = \frac{75^\circ\text{C} - 25^\circ\text{C}}{(56.1 + 0.958) \text{ K/W}} + \frac{75^\circ\text{C} - 25^\circ\text{C}}{0.120 + 1.26} = 0.876 \text{ W} + 36.1 \text{ W} = 37.0 \text{ W}$$

<

The figure shows the variation of the allowable heat rate as the dust layer thickness varies.

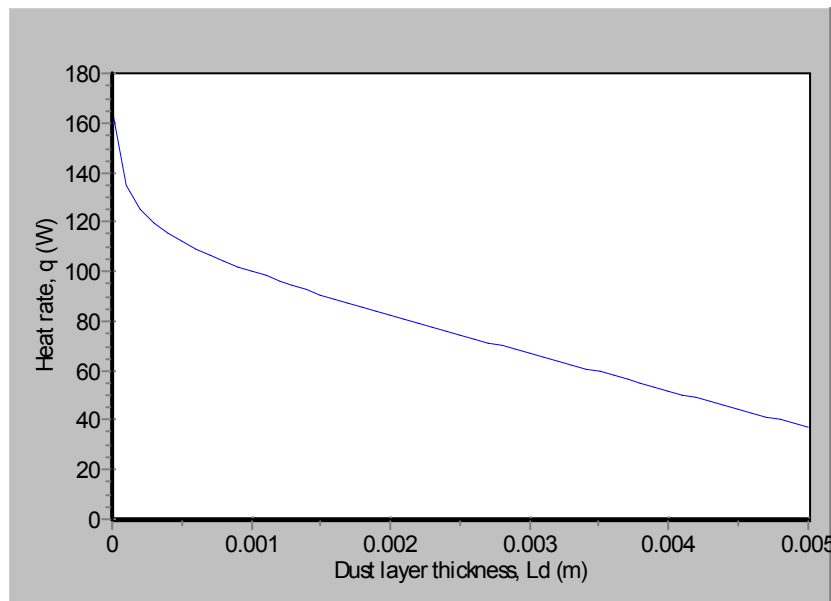

**COMMENTS:** The figure below shows the two contributions to the heat rate,  $q_{\text{dust}}$  and  $q_{\text{fin}}$ . The heat transfer through the dust layer decreases rapidly as the dust layer thickness increases and insulates the surface. The fin heat transfer also decreases with increasing dust layer thickness as more of the fin surface is insulated by the dust.

Continued...



### PROBLEM 3.152 (Cont.)

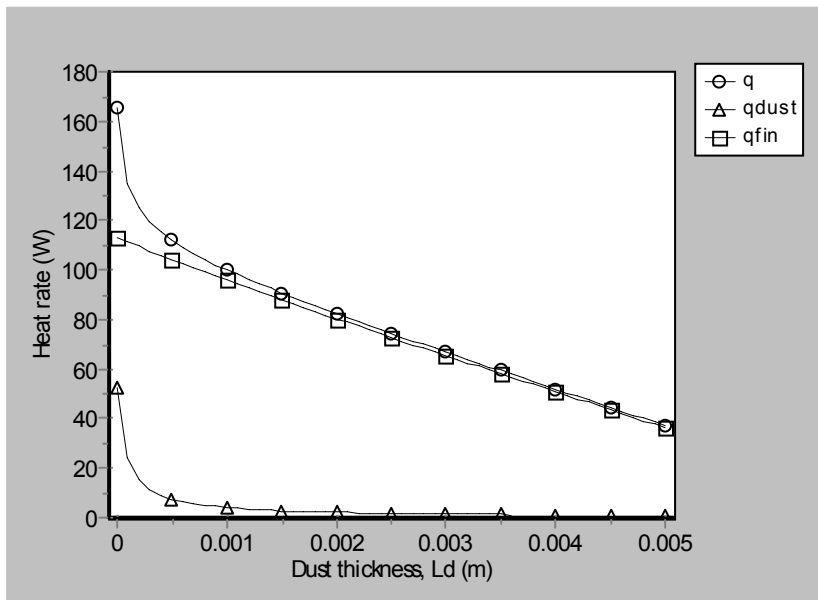

### PROBLEM 3.153

**KNOWN:** Long rod with internal volumetric generation covered by an electrically insulating sleeve and supported with a ribbed spider.

**FIND:** Combination of convection coefficient, spider design, and sleeve thermal conductivity which enhances volumetric heating subject to a maximum centerline temperature of 100°C.

**SCHEMATIC:**

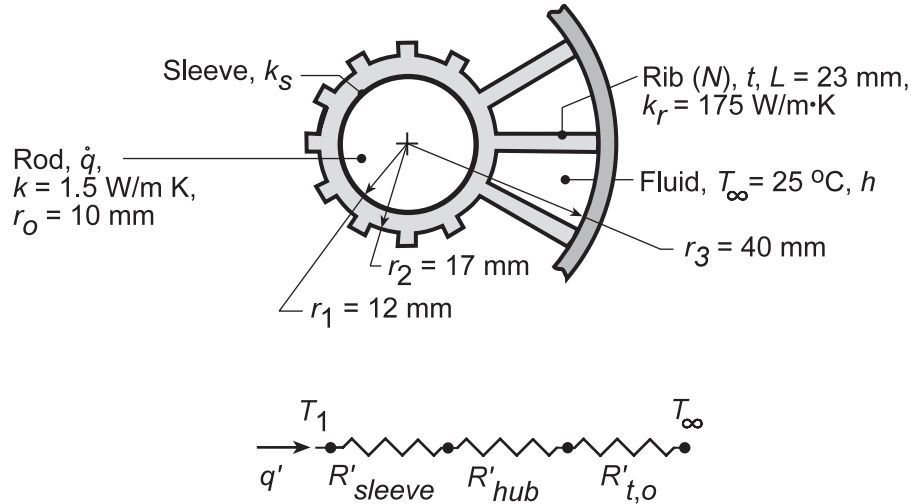

**ASSUMPTIONS:** (1) Steady-state conditions, (2) One-dimensional radial heat transfer in rod, sleeve and hub, (3) Negligible interfacial contact resistances, (4) Constant properties, (5) Adiabatic outer surface.

**ANALYSIS:** The system heat rate per unit length may be expressed as

$$q' = \dot{q} (\pi r_o^2) = \frac{T_1 - T_\infty}{R'_{\text{sleeve}} + R'_{\text{hub}} + R'_{t,o}}$$

where

$$R'_{\text{sleeve}} = \frac{\ln(r_1/r_o)}{2\pi k_s}, \quad R'_{\text{hub}} = \frac{\ln(r_2/r_1)}{2\pi k_r} = 3.168 \times 10^{-4} \text{ m} \cdot \text{K}/\text{W}, \quad R'_{t,o} = \frac{1}{\eta_o h A'_t},$$

$$\eta_o = 1 - \frac{N A'_f}{A'_t} (1 - \eta_f), \quad A'_f = 2(r_3 - r_2), \quad A'_t = N A'_f + (2\pi r_3 - N t),$$

$$\eta_f = \frac{\tanh m(r_3 - r_2)}{m(r_3 - r_2)}, \quad m = (2h/k_r t)^{1/2}.$$

The rod centerline temperature is related to  $T_1$  through

$$T_o = T(0) = T_1 + \frac{\dot{q} r_o^2}{4k}$$

Calculations may be expedited by using the IHT *Performance Calculation, Extended Surface Model* for the *Straight Fin Array*. For base case conditions of  $k_s = 0.5 \text{ W/m} \cdot \text{K}$ ,  $h = 20 \text{ W/m}^2 \cdot \text{K}$ ,  $t = 4 \text{ mm}$  and  $N = 12$ ,  $R'_{\text{sleeve}} = 0.0580 \text{ m} \cdot \text{K}/\text{W}$ ,  $R'_{t,o} = 0.0826 \text{ m} \cdot \text{K}/\text{W}$ ,  $\eta_f = 0.990$ ,  $q' = 387 \text{ W/m}$ , and  $\dot{q} = 1.23 \times 10^6 \text{ W/m}^3$ . As shown below,  $\dot{q}$  may be increased by increasing  $h$ , where  $h = 250 \text{ W/m}^2 \cdot \text{K}$  represents a reasonable upper limit for airflow. However, a more than 10-fold increase in  $h$  yields only a 63% increase in  $\dot{q}$ .

Continued...

### PROBLEM 3.153 (Cont.)

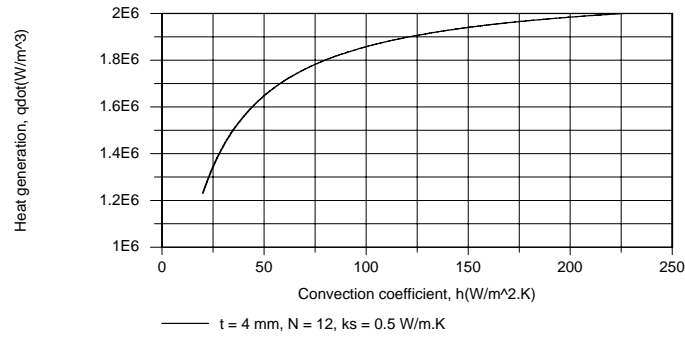

The difficulty is that, by significantly increasing  $h$ , the thermal resistance of the fin array is reduced to  $0.00727 \text{ m}\cdot\text{K}/\text{W}$ , rendering the sleeve the dominant contributor to the total resistance.

Similar results are obtained when  $N$  and  $t$  are varied. For values of  $t = 2, 3$  and  $4 \text{ mm}$ , variations of  $N$  in the respective ranges  $12 \leq N \leq 26$ ,  $12 \leq N \leq 21$  and  $12 \leq N \leq 17$  were considered. The upper limit on  $N$  was fixed by requiring that  $(S - t) \geq 2 \text{ mm}$  to avoid an excessive resistance to airflow between the ribs. As shown below, the effect of increasing  $N$  is small, and there is little difference between results for the three values of  $t$ .

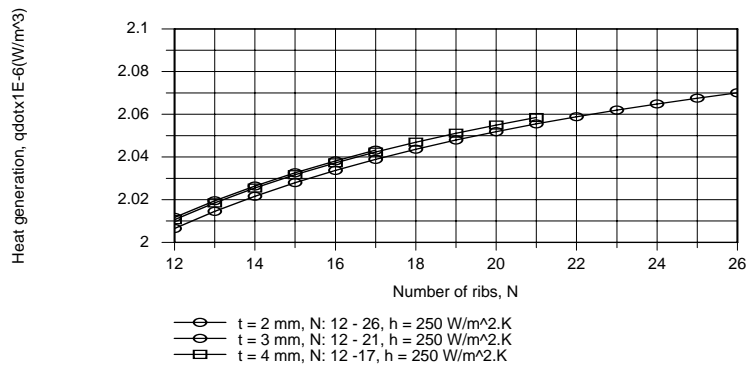

In contrast, significant improvement is associated with changing the sleeve material, and it is only necessary to have  $k_s \approx 25 \text{ W}/\text{m}\cdot\text{K}$  (e.g. a boron sleeve) to approach an upper limit to the influence of  $k_s$ .

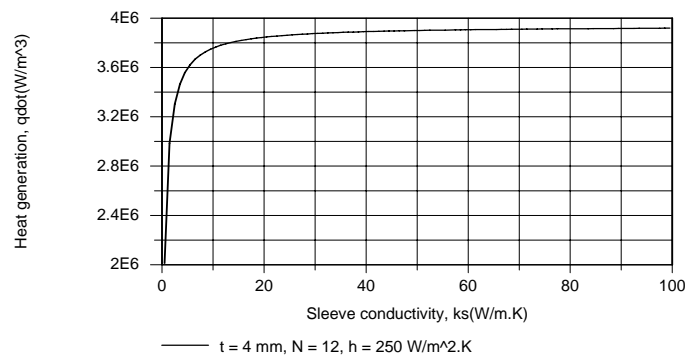

For  $h = 250 \text{ W}/\text{m}^2\cdot\text{K}$  and  $k_s = 25 \text{ W}/\text{m}\cdot\text{K}$ , only a slight improvement is obtained by increasing  $N$ . Hence, the recommended conditions are:

$$h = 250 \text{ W}/\text{m}^2\cdot\text{K}, \quad k_s = 25 \text{ W}/\text{m}\cdot\text{K}, \quad N = 12, \quad t = 4 \text{ mm} \quad \triangleleft$$

**COMMENTS:** The upper limit to  $\dot{q}$  is reached as the total thermal resistance approaches zero, in which case  $T_1 \rightarrow T_\infty$ . Hence  $\dot{q}_{\text{max}} = 4k(T_0 - T_\infty)/r_0^2 = 4.5 \times 10^6 \text{ W}/\text{m}^3$ .

### PROBLEM 3.154

**KNOWN:** Geometrical and convection conditions of internally finned, concentric tube air heater.

**FIND:** (a) Thermal circuit, (b) Heat rate per unit tube length, (c) Effect of changes in fin array.

**SCHEMATIC:**

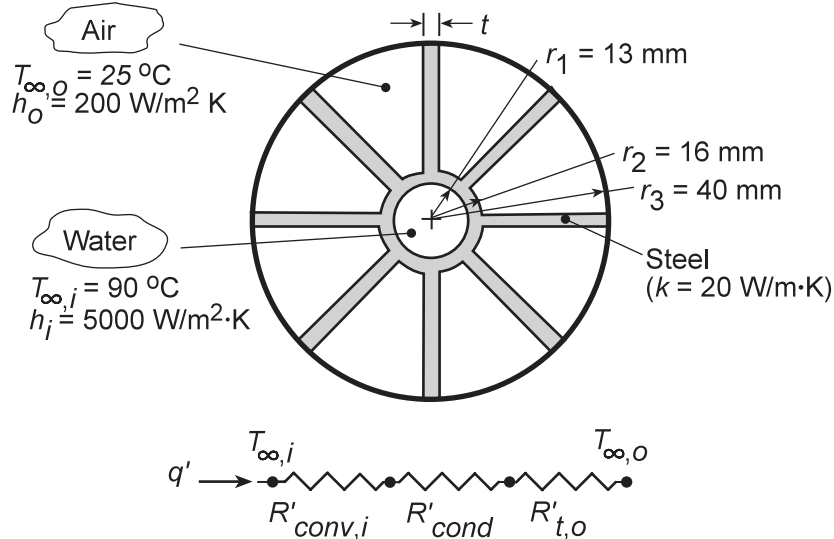

**ASSUMPTIONS:** (1) Steady-state conditions, (2) One-dimensional heat transfer in radial direction, (3) Constant  $k$ , (4) Adiabatic outer surface.

**ANALYSIS:** (a) For the thermal circuit shown schematically,

$$R'_{\text{conv},i} = (h_i 2\pi r_1)^{-1}, \quad R'_{\text{cond}} = \ln(r_2/r_1)/2\pi k, \quad \text{and} \quad R'_{t,o} = (\eta_o h_o A'_t)^{-1},$$

where

$$\eta_o = 1 - \frac{NA'_f}{A'_t} (1 - \eta_f), \quad A'_f = 2L = 2(r_3 - r_2), \quad A'_t = NA'_f + (2\pi r_2 - Nt), \quad \text{and} \quad \eta_f = \frac{\tanh mL}{mL}.$$

$$(b) \quad q' = \frac{(T_{\infty,i} - T_{\infty,o})}{R'_{\text{conv},i} + R'_{\text{cond}} + R'_{t,o}}$$

Substituting the known conditions, it follows that

$$R'_{\text{conv},i} = \left(5000 \text{ W/m}^2 \cdot \text{K} \times 2\pi \times 0.013 \text{ m}\right)^{-1} = 2.45 \times 10^{-3} \text{ m} \cdot \text{K/W}$$

$$R'_{\text{cond}} = \ln(0.016 \text{ m}/0.013 \text{ m})/2\pi(20 \text{ W/m} \cdot \text{K}) = 1.65 \times 10^{-3} \text{ m} \cdot \text{K/W}$$

$$R'_{t,o} = \left(0.575 \times 200 \text{ W/m}^2 \cdot \text{K} \times 0.461 \text{ m}\right)^{-1} = 18.86 \times 10^{-3} \text{ m} \cdot \text{K/W}$$

where  $\eta_f = 0.490$ . Hence,

$$q' = \frac{(90 - 25)^\circ \text{C}}{(2.45 + 1.65 + 18.86) \times 10^{-3} \text{ m} \cdot \text{K/W}} = 2831 \text{ W/m} \quad <$$

(c) The small value of  $\eta_f$  suggests that some benefit may be gained by increasing  $t$ , as well as by increasing  $N$ . With the requirement that  $Nt \leq 50 \text{ mm}$ , we use the IHT *Performance Calculation, Extended Surface Model* for the *Straight Fin Array* to consider the following range of conditions:  $t = 2 \text{ mm}$ ,  $12 \leq N \leq 25$ ;  $t = 3 \text{ mm}$ ,  $8 \leq N \leq 16$ ;  $t = 4 \text{ mm}$ ,  $6 \leq N \leq 12$ ;  $t = 5 \text{ mm}$ ,  $5 \leq N \leq 10$ . Calculations based on the foregoing model are plotted as follows.

Continued...

### PROBLEM 3.154 (Cont.)

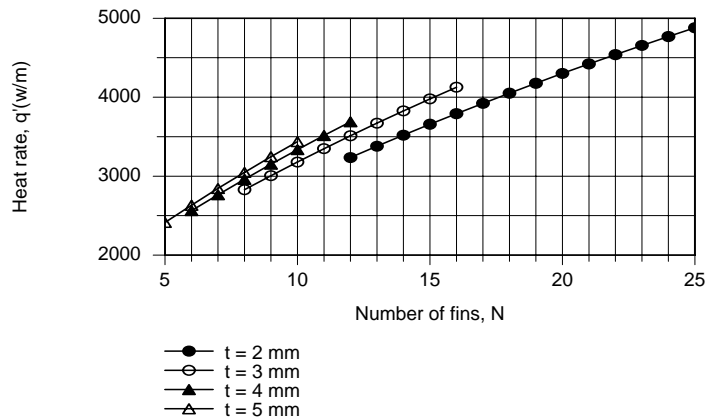

By increasing  $t$  from 2 to 5 mm,  $\eta_f$  increases from 0.410 to 0.598. Hence, for fixed  $N$ ,  $q'$  increases with increasing  $t$ . However, from the standpoint of maximizing  $q'_t$ , it is clearly preferable to use the larger number of thinner fins. Hence, subject to the prescribed constraint, we would choose  $t = 2$  mm and  $N = 25$ , for which  $q' = 4880$  W/m.

**COMMENTS:** (1) The air side resistance makes the dominant contribution to the total resistance, and efforts to increase  $q'$  by reducing  $R'_{t,o}$  are well directed. (2) A fin thickness any smaller than 2 mm would be difficult to manufacture.

### PROBLEM 3.155

**KNOWN:** Dimensions and number of rectangular aluminum fins. Convection coefficient with and without fins.

**FIND:** Percentage increase in heat transfer resulting from use of fins.

**SCHEMATIC:**

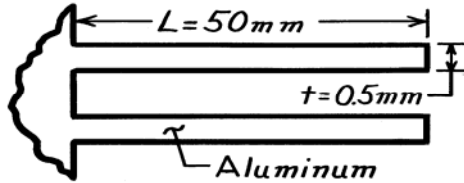

$$\begin{aligned}
 N &= 250 \text{ m}^{-1} \\
 w &= \text{width} \\
 h_w &= 30 \text{ W/m}^2 \cdot \text{K} \text{ (with fins)} \\
 h_{w0} &= 40 \text{ W/m}^2 \cdot \text{K} \text{ (without fins)}
 \end{aligned}$$

**ASSUMPTIONS:** (1) Steady-state conditions, (2) One-dimensional conduction, (3) Constant properties, (4) Negligible radiation, (5) Negligible fin contact resistance, (6) Uniform convection coefficient.

**PROPERTIES:** Table A-1, Aluminum, pure:  $k \approx 240 \text{ W/m} \cdot \text{K}$ .

**ANALYSIS:** Evaluate the fin parameters

$$L_c = L + t/2 = 0.05025 \text{ m}$$

$$A_p = L_c t = 0.05025 \text{ m} \times 0.5 \times 10^{-3} \text{ m} = 25.13 \times 10^{-6} \text{ m}^2$$

$$L_c^{3/2} (h_w / k A_p)^{1/2} = (0.05025 \text{ m})^{3/2} \left[ \frac{30 \text{ W/m}^2 \cdot \text{K}}{240 \text{ W/m} \cdot \text{K} \times 25.13 \times 10^{-6} \text{ m}^2} \right]^{1/2}$$

$$L_c^{3/2} (h_w / k A_p)^{1/2} = 0.794$$

It follows from Fig. 3.19 that  $\eta_f \approx 0.72$ . Hence,

$$q_f = \eta_f q_{\max} = 0.72 h_w 2wL \theta_b$$

$$q_f = 0.72 \times 30 \text{ W/m}^2 \cdot \text{K} \times 2 \times 0.05 \text{ m} \times (w \theta_b) = 2.16 \text{ W/m} \cdot \text{K} (w \theta_b)$$

With the fins, the heat transfer from the walls is

$$q_w = N q_f + (1 - Nt) w h_w \theta_b$$

$$q_w = 250 \times 2.16 \frac{\text{W}}{\text{m} \cdot \text{K}} (w \theta_b) + (1 - 250 \times 5 \times 10^{-4}) \times 30 \text{ W/m}^2 \cdot \text{K} (w \theta_b)$$

$$q_w = (540 + 26.3) \frac{\text{W}}{\text{m} \cdot \text{K}} (w \theta_b) = 566 w \theta_b.$$

Without the fins,  $q_{w0} = h_{w0} 1 \text{ m} \times w \theta_b = 40 w \theta_b$ . Hence the percentage increase in heat transfer is

$$\frac{q_w - q_{w0}}{q_{w0}} = \frac{(566 - 40) w \theta_b}{40 w \theta_b} = 13.15 = 1315\% \quad \leftarrow$$

**COMMENTS:** If the infinite fin approximation is made, it follows that  $q_f = (hPkA_c)^{1/2} \theta_b = [h_w 2wkwt]^{1/2} \theta_b = (30 \times 2 \times 240 \times 5 \times 10^{-4})^{1/2} w \theta_b = 2.68 w \theta_b$ . Hence,  $q_f$  is overestimated.

### PROBLEM 3.156

**KNOWN:** Wall with known heat generation rate, thermal conductivity, and thickness. Dimensions and thermal conductivity of fins. Heat transfer coefficients and environment temperatures.

**FIND:** Maximum temperature.

**SCHEMATIC:**

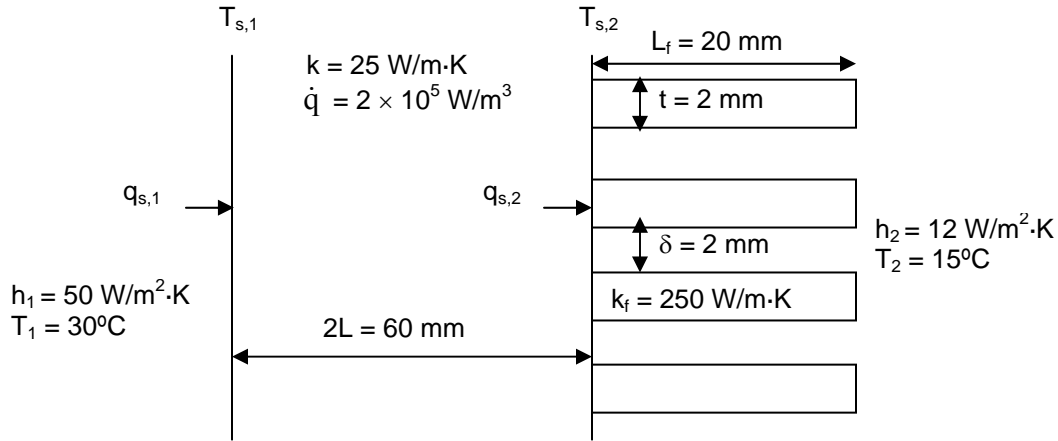

**ASSUMPTIONS:** (1) Steady-state conditions, (2) Wall surface temperatures are uniform. (3) No contact resistance between fins and wall, (4) Heat transfer from the fin tips can be neglected.

**ANALYSIS:** The temperature distribution in a wall with uniform volumetric heat generation and specified temperature boundary conditions is, from Equation 3.46

$$T(x) = \frac{\dot{q}L^2}{2k} \left( 1 - \frac{x^2}{L^2} \right) + \frac{T_{s,2} - T_{s,1}}{2} \frac{x}{L} + \frac{T_{s,1} + T_{s,2}}{2} \quad (1)$$

The heat transfer rates at the two surfaces, for a wall section of area  $A$ , can be found from Fourier's law:

$$q_{s,1} = -kA \left. \frac{dT}{dx} \right|_{x=-L} = -\dot{q}LA - kA \frac{T_{s,2} - T_{s,1}}{2L} \quad (2)$$

$$q_{s,2} = -kA \left. \frac{dT}{dx} \right|_{x=L} = \dot{q}LA - kA \frac{T_{s,2} - T_{s,1}}{2L} \quad (3)$$

We can express these same heat transfer rates alternatively, as follows:

$$q_{s,1} = h_1 A (T_1 - T_{s,1}) \quad (4)$$

$$q_{s,2} = h_2 A_t (T_{s,2} - T_2) \eta_o \quad (5)$$

where  $\eta_o$  is given by Equation 3.107. Equating the two expressions for  $q_{s,1}$ , Equations (2) and (4), and equating the expressions for  $q_{s,2}$ , Equations (3) and (5), and solving for  $T_{s,1}$  and  $T_{s,2}$  yields

Continued...

**PROBLEM 3.156 (Cont.)**

$$T_{s,1} = \frac{\left(\frac{k}{2L} + h_2\tilde{A}\right)h_1T_1 + \frac{k}{2L}h_2\tilde{A}T_2 + \left(\frac{k}{L} + h_2\tilde{A}\right)\dot{q}L}{\frac{kh_1}{2L} + h_1h_2\tilde{A} + \frac{kh_2\tilde{A}}{2L}}$$

$$T_{s,2} = \frac{\frac{k}{2L}h_1T_1 + \left(\frac{k}{2L} + h_1\right)h_2\tilde{A}T_2 + \left(\frac{k}{L} + h_1\right)\dot{q}L}{\frac{kh_1}{2L} + h_1h_2\tilde{A} + \frac{kh_2\tilde{A}}{2L}}$$

where

$$\tilde{A} = \frac{A_t\eta_o}{A} = \frac{A_t}{A} - \frac{NA_f}{A}(1 - \eta_f)$$

Performing the calculations:

$$m = \sqrt{\frac{h_2P}{k_fA_c}} = \sqrt{\frac{2h_2}{k_ft}} = \sqrt{\frac{2 \times 12 \text{ W/m}^2 \cdot \text{K}}{250 \text{ W/m} \cdot \text{K} \times 0.002 \text{ m}}} = 6.9 \text{ m}^{-1}$$

$$\eta_f = \frac{\tanh(mL_f)}{mL_f} = \frac{\tanh(6.9 \text{ m}^{-1} \times 0.02 \text{ m})}{6.9 \text{ m}^{-1} \times 0.02 \text{ m}} = 0.994$$

$$\frac{NA_f}{A} = \frac{N2wL_f}{(\delta+t)Nw} = \frac{2L_f}{\delta+t} = \frac{2 \times 0.02 \text{ m}}{0.004 \text{ m}} = 10.0$$

$$\frac{A_t}{A} = \frac{NA_f}{A} + \frac{A_b}{A} = \frac{NA_f}{A} + \frac{\delta Nw}{(\delta+t)Nw} = \frac{NA_f}{A} + \frac{\delta}{\delta+t} = 10. + \frac{0.002 \text{ m}}{0.004 \text{ m}} = 10.5$$

$$\tilde{A} = 10.5 - 10.(1 - 0.994) = 10.4$$

$$h_2\tilde{A} = 12 \text{ W/m}^2 \cdot \text{K} \times 10.4 = 125 \text{ W/m}^2 \cdot \text{K}$$

$$\frac{k}{2L} = \frac{25 \text{ W/m} \cdot \text{K}}{0.06 \text{ m}} = 417 \text{ W/m}^2 \cdot \text{K}$$

Thus

$$T_{s,1} = \frac{\left( \begin{array}{l} (417+125) \text{ W/m}^2 \cdot \text{K} \times 50 \text{ W/m}^2 \cdot \text{K} \times 30^\circ\text{C} \\ + 417 \text{ W/m}^2 \cdot \text{K} \times 125 \text{ W/m}^2 \cdot \text{K} \times 15^\circ\text{C} \\ + (2 \times 417 + 125) \text{ W/m}^2 \cdot \text{K} \times 2 \times 10^5 \text{ W/m}^3 \times 0.03 \text{ m} \end{array} \right)}{\left( \begin{array}{l} (417 \times 50 \\ + 50 \times 125 \\ + 417 \times 125) (\text{W/m}^2 \cdot \text{K})^2 \end{array} \right)}$$

Continued...



### PROBLEM 3.156 (Cont.)

$$T_{s,1} = 92.7^\circ\text{C}$$

Similarly,

$$T_{s,2} = 85.8^\circ\text{C}$$

The location of the maximum temperature in the wall can be found by setting the gradient of the temperature (from Equation (1)) to zero:

$$\frac{dT}{dx} = -\frac{\dot{q}x}{k} + \frac{T_{s,2} - T_{s,1}}{2L} = 0$$

Thus,  $x_{\max} = k \frac{T_{s,2} - T_{s,1}}{2L\dot{q}}$ . Substituting this back into the temperature distribution,

$$\begin{aligned} T_{\max} &= \frac{\dot{q}L^2}{2k} + \frac{k(T_{s,2} - T_{s,1})^2}{8L^2\dot{q}} + \frac{T_{s,1} + T_{s,2}}{2} \\ &= \frac{2 \times 10^5 \text{ W/m}^3 \times (0.03 \text{ m})^2}{2 \times 25 \text{ W/m} \cdot \text{K}} + \frac{25 \text{ W/m} \cdot \text{K} (85.8^\circ\text{C} - 92.7^\circ\text{C})^2}{8 \times (0.03 \text{ m})^2 \times 2 \times 10^5 \text{ W/m}^3} \\ &\quad + \frac{92.7^\circ\text{C} + 85.8^\circ\text{C}}{2} = 93.7^\circ\text{C} \end{aligned} \quad <$$

### PROBLEM 3.157

**KNOWN:** Dimensions, base temperature and environmental conditions associated with a triangular, aluminum fin.

**FIND:** (a) Fin efficiency and effectiveness, (b) Heat dissipation per unit width.

**SCHEMATIC:**

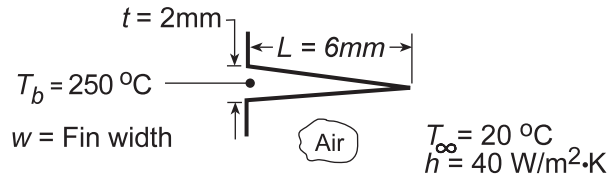

**ASSUMPTIONS:** (1) Steady-state conditions, (2) One-dimensional conduction, (3) Constant properties, (4) Negligible radiation and base contact resistance, (5) Uniform convection coefficient.

**PROPERTIES:** Table A-1, Aluminum, pure ( $T \approx 400\text{ K}$ ):  $k = 240\text{ W/m}\cdot\text{K}$ .

**ANALYSIS:** (a) With  $L_c = L = 0.006\text{ m}$ , find

$$A_p = Lt/2 = (0.006\text{ m})(0.002\text{ m})/2 = 6 \times 10^{-6}\text{ m}^2,$$

$$L_c^{3/2} (h/kA_p)^{1/2} = (0.006\text{ m})^{3/2} \left( \frac{40\text{ W/m}^2 \cdot \text{K}}{240\text{ W/m} \cdot \text{K} \times 6 \times 10^{-6}\text{ m}^2} \right)^{1/2} = 0.077$$

and from Fig. 3.19, the fin efficiency is

$$\eta_f \approx 0.99.$$

From Eq. 3.91 and Table 3.5, the fin heat rate is

$$q_f = \eta_f q_{\max} = \eta_f h A_{f(\text{tri})} \theta_b = 2\eta_f h w \left[ L^2 + (t/2)^2 \right]^{1/2} \theta_b.$$

From Eq. 3.86, the fin effectiveness is

$$\varepsilon_f = \frac{q_f}{h A_{c,b} \theta_b} = \frac{2\eta_f h w \left[ L^2 + (t/2)^2 \right]^{1/2} \theta_b}{h (w \cdot t) \theta_b} = \frac{2\eta_f \left[ L^2 + (t/2)^2 \right]^{1/2}}{t}$$

$$\varepsilon_f = \frac{2 \times 0.99 \left[ (0.006)^2 + (0.002/2)^2 \right]^{1/2}\text{ m}}{0.002\text{ m}} = 6.02$$

(b) The heat dissipation per unit width is

$$q'_f = (q_f/w) = 2\eta_f h \left[ L^2 + (t/2)^2 \right]^{1/2} \theta_b$$

$$q'_f = 2 \times 0.99 \times 40\text{ W/m}^2 \cdot \text{K} \left[ (0.006)^2 + (0.002/2)^2 \right]^{1/2}\text{ m} \times (250 - 20)^\circ\text{C} = 110.8\text{ W/m}.$$

**COMMENTS:** The parabolic profile is known to provide the maximum heat dissipation per unit fin mass.

### PROBLEM 3.158

**KNOWN:** Dimensions and base temperature of an annular, aluminum fin of rectangular profile. Ambient air conditions.

**FIND:** (a) Fin heat loss, (b) Heat loss per unit length of tube with 200 fins spaced at 5 mm increments.

**SCHEMATIC:**

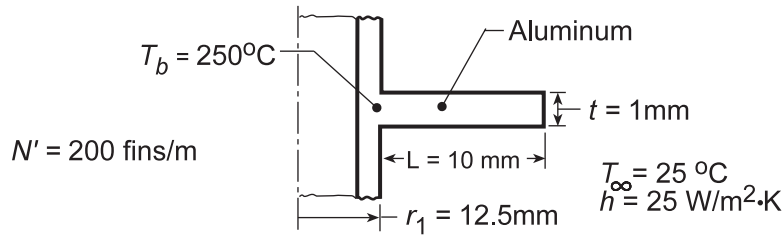

**ASSUMPTIONS:** (1) Steady-state conditions, (2) One-dimensional conduction, (3) Constant properties, (4) Negligible radiation and contact resistance, (5) Uniform convection coefficient.

**PROPERTIES:** Table A-1, Aluminum, pure ( $T \approx 400$  K):  $k = 240$  W/m·K.

**ANALYSIS:** (a) The fin parameters for use with Figure 3.20 are

$$r_{2c} = r_2 + t/2 = (12.5 \text{ mm} + 10 \text{ mm}) + 0.5 \text{ mm} = 23 \text{ mm} = 0.023 \text{ m}$$

$$r_{2c}/r_1 = 1.84 \quad L_c = L + t/2 = 10.5 \text{ mm} = 0.0105 \text{ m}$$

$$A_p = L_c t = 0.0105 \text{ m} \times 0.001 \text{ m} = 1.05 \times 10^{-5} \text{ m}^2$$

$$L_c^{3/2} (h/kA_p)^{1/2} = (0.0105 \text{ m})^{3/2} \left( \frac{25 \text{ W/m}^2 \cdot \text{K}}{240 \text{ W/m} \cdot \text{K} \times 1.05 \times 10^{-5} \text{ m}^2} \right)^{1/2} = 0.15.$$

Hence, the fin effectiveness is  $\eta_f \approx 0.97$ , and from Eq. 3.91 and Fig. 3.6, the fin heat rate is

$$q_f = \eta_f q_{\max} = \eta_f h A_{f(\text{ann})} \theta_b = 2\pi \eta_f h (r_{2c}^2 - r_1^2) \theta_b$$

$$q_f = 2\pi \times 0.97 \times 25 \text{ W/m}^2 \cdot \text{K} \times \left[ (0.023 \text{ m})^2 - (0.0125 \text{ m})^2 \right] 225^\circ \text{C} = 12.8 \text{ W}. \quad <$$

(b) Recognizing that there are  $N = 200$  fins per meter length of the tube, the total heat rate considering contributions due to the fin and base (unfinned) surfaces is

$$q' = N' q_f + h(1 - N't) 2\pi r_1 \theta_b$$

$$q' = 200 \text{ m}^{-1} \times 12.8 \text{ W} + 25 \text{ W/m}^2 \cdot \text{K} \left( 1 - 200 \text{ m}^{-1} \times 0.001 \text{ m} \right) \times 2\pi \times (0.0125 \text{ m}) 225^\circ \text{C}$$

$$q' = (2560 \text{ W} + 353 \text{ W})/\text{m} = 2.91 \text{ kW/m}. \quad <$$

**COMMENTS:** Note that, while covering only 20% of the tube surface area, the tubes account for more than 85% of the total heat dissipation.

### PROBLEM 3.159

**KNOWN:** Dimensions and base temperature of aluminum fins of rectangular profile. Ambient air conditions.

**FIND:** (a) Fin efficiency and effectiveness, (b) Rate of heat transfer per unit length of tube.

**SCHEMATIC:**

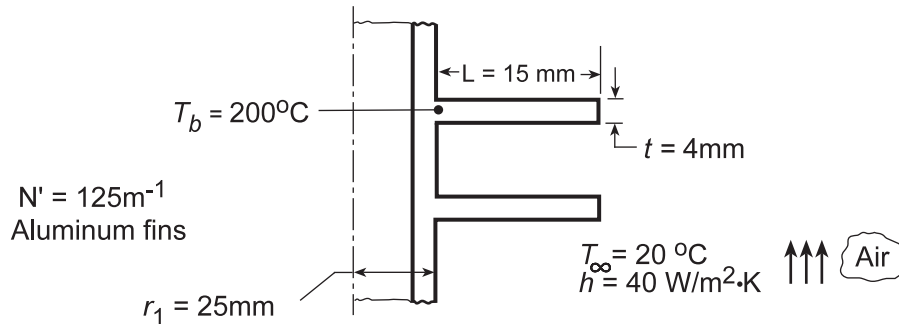

**ASSUMPTIONS:** (1) Steady-state conditions, (2) One-dimensional radial conduction in fins, (3) Constant properties, (4) Negligible radiation, (5) Negligible base contact resistance, (6) Uniform convection coefficient.

**PROPERTIES:** Table A-1, Aluminum, pure ( $T \approx 400$  K):  $k = 240$  W/m·K.

**ANALYSIS:** (a) The fin parameters for use with Figure 3.20 are

$$r_{2c} = r_2 + t/2 = 40 \text{ mm} + 2 \text{ mm} = 0.042 \text{ m} \quad L_c = L + t/2 = 15 \text{ mm} + 2 \text{ mm} = 0.017 \text{ m}$$

$$r_{2c}/r_1 = 0.042 \text{ m}/0.025 \text{ m} = 1.68 \quad A_p = L_c t = 0.017 \text{ m} \times 0.004 \text{ m} = 6.8 \times 10^{-5} \text{ m}^2$$

$$L_c^{3/2} (h/kA_p)^{1/2} = (0.017 \text{ m})^{3/2} \left[ 40 \text{ W/m}^2 \cdot \text{K} / 240 \text{ W/m} \cdot \text{K} \times 6.8 \times 10^{-5} \text{ m}^2 \right]^{1/2} = 0.11$$

The fin efficiency is  $\eta_f \approx 0.97$ . From Eq. 3.91,

$$q_f = \eta_f q_{\max} = \eta_f h A_{f(\text{ann})} \theta_b = 2\pi \eta_f h \left[ r_{2c}^2 - r_1^2 \right] \theta_b$$

$$q_f = 2\pi \times 0.97 \times 40 \text{ W/m}^2 \cdot \text{K} \left[ (0.042)^2 - (0.025)^2 \right] \text{m}^2 \times 180^\circ \text{C} = 50 \text{ W} \quad <$$

From Eq. 3.86, the fin effectiveness is

$$\varepsilon_f = \frac{q_f}{h A_{c,b} \theta_b} = \frac{50 \text{ W}}{40 \text{ W/m}^2 \cdot \text{K} \cdot 2\pi (0.025 \text{ m})(0.004 \text{ m}) 180^\circ \text{C}} = 11.05 \quad <$$

(b) The rate of heat transfer per unit length is

$$q' = N' q_f + h(1 - N't)(2\pi r_1) \theta_b$$

$$q' = 125 \times 50 \text{ W/m} + 40 \text{ W/m}^2 \cdot \text{K} (1 - 125 \times 0.004)(2\pi \times 0.025 \text{ m}) \times 180^\circ \text{C}$$

$$q' = (6250 + 565) \text{ W/m} = 6.82 \text{ kW/m} \quad <$$

**COMMENTS:** Note the dominant contribution made by the fins to the total heat transfer.

### PROBLEM 3.160

**KNOWN:** Dimensions and materials of a finned (annular) cylinder wall. Heat flux and ambient air conditions. Contact resistance.

**FIND:** Surface and interface temperatures (a) without and (b) with an interface contact resistance.

**SCHEMATIC:**

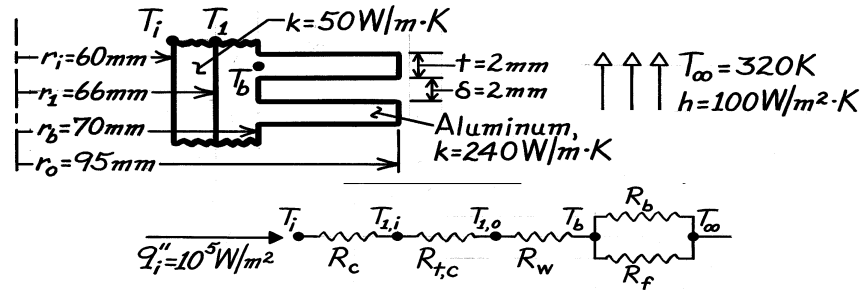

**ASSUMPTIONS:** (1) One-dimensional, steady-state conditions, (2) Constant properties, (3) Uniform  $h$  over surfaces, (4) Negligible radiation.

**ANALYSIS:** The analysis may be performed per unit length of cylinder or for a 4 mm long section. The following calculations are based on a unit length. The inner surface temperature may be obtained from

$$q' = \frac{T_i - T_\infty}{R'_{\text{tot}}} = q''_i (2\pi r_1) = 10^5 \text{ W/m}^2 \times 2\pi \times 0.06 \text{ m} = 37,700 \text{ W/m}$$

where  $R'_{\text{tot}} = R'_c + R'_{t,c} + R'_w + R'_{\text{equiv}}$ ;  $R'_{\text{equiv}} = (1/R'_f + 1/R'_b)^{-1}$ .

$R'_c$ , Conduction resistance of cylinder wall:

$$R'_c = \frac{\ln(r_1/r_i)}{2\pi k} = \frac{\ln(66/60)}{2\pi (50 \text{ W/m}\cdot\text{K})} = 3.034 \times 10^{-4} \text{ m}\cdot\text{K/W}$$

$R'_{t,c}$ , Contact resistance:

$$R'_{t,c} = R''_{t,c} / 2\pi r_1 = 10^{-4} \text{ m}^2 \cdot \text{K/W} / 2\pi \times 0.066 \text{ m} = 2.411 \times 10^{-4} \text{ m}\cdot\text{K/W}$$

$R'_w$ , Conduction resistance of aluminum base:

$$R'_w = \frac{\ln(r_b/r_1)}{2\pi k} = \frac{\ln(70/66)}{2\pi \times 240 \text{ W/m}\cdot\text{K}} = 3.902 \times 10^{-5} \text{ m}\cdot\text{K/W}$$

$R'_b$ , Resistance of prime or unfinned surface:

$$R'_b = \frac{1}{hA'_b} = \frac{1}{100 \text{ W/m}^2 \cdot \text{K} \times 0.5 \times 2\pi (0.07 \text{ m})} = 454.7 \times 10^{-4} \text{ m}\cdot\text{K/W}$$

$R'_f$ , Resistance of fins: The fin resistance may be determined from

$$R'_f = \frac{T_b - T_\infty}{q'_f} = \frac{1}{\eta_f h A'_f}$$

The fin efficiency may be obtained from Fig. 3.20,

$$r_{2c} = r_o + t/2 = 0.096 \text{ m} \quad L_c = L + t/2 = 0.026 \text{ m}$$

Continued ...

**PROBLEM 3.160 (Cont.)**

$$A_p = L_c t = 5.2 \times 10^{-5} \text{ m}^2 \quad r_{2c} / r_1 = 1.45 \quad L_c^{3/2} (h/kA_p)^{1/2} = 0.375$$

Fig. 3.20  $\rightarrow \eta_f \approx 0.88$ .

The total fin surface area per meter length

$$A'_f = 250 \left[ \pi (r_o^2 - r_b^2) \times 2 \right] = 250 \text{ m}^{-1} \left[ 2\pi (0.096^2 - 0.07^2) \right] \text{ m}^2 = 6.78 \text{ m}.$$

Hence 
$$R'_f = \left[ 0.88 \times 100 \text{ W/m}^2 \cdot \text{K} \times 6.78 \text{ m} \right]^{-1} = 16.8 \times 10^{-4} \text{ m} \cdot \text{K/W}$$

$$1/R'_{\text{equiv}} = \left( 1/16.8 \times 10^{-4} + 1/454.7 \times 10^{-4} \right) \text{ W/m} \cdot \text{K} = 617.2 \text{ W/m} \cdot \text{K}$$

$$R'_{\text{equiv}} = 16.2 \times 10^{-4} \text{ m} \cdot \text{K/W}.$$

Neglecting the *contact resistance*,

$$R'_{\text{tot}} = (3.034 + 0.390 + 16.2) 10^{-4} \text{ m} \cdot \text{K/W} = 19.6 \times 10^{-4} \text{ m} \cdot \text{K/W}$$

$$T_i = q'R'_{\text{tot}} + T_\infty = 37,700 \text{ W/m} \times 19.6 \times 10^{-4} \text{ m} \cdot \text{K/W} + 320 \text{ K} = 393.9 \text{ K} \quad <$$

$$T_1 = T_i - q'R'_w = 393.9 \text{ K} - 37,700 \text{ W/m} \times 3.034 \times 10^{-4} \text{ m} \cdot \text{K/W} = 382.5 \text{ K} \quad <$$

$$T_b = T_1 - q'R'_b = 382.5 \text{ K} - 37,700 \text{ W/m} \times 3.902 \times 10^{-5} \text{ m} \cdot \text{K/W} = 381.0 \text{ K}. \quad <$$

Including the *contact resistance*,

$$R'_{\text{tot}} = \left( 19.6 \times 10^{-4} + 2.411 \times 10^{-4} \right) \text{ m} \cdot \text{K/W} = 22.0 \times 10^{-4} \text{ m} \cdot \text{K/W}$$

$$T_i = 37,700 \text{ W/m} \times 22.0 \times 10^{-4} \text{ m} \cdot \text{K/W} + 320 \text{ K} = 402.9 \text{ K} \quad <$$

$$T_{1,i} = 402.9 \text{ K} - 37,700 \text{ W/m} \times 3.034 \times 10^{-4} \text{ m} \cdot \text{K/W} = 391.5 \text{ K} \quad <$$

$$T_{1,o} = 391.5 \text{ K} - 37,700 \text{ W/m} \times 2.411 \times 10^{-4} \text{ m} \cdot \text{K/W} = 382.4 \text{ K} \quad <$$

$$T_b = 382.4 \text{ K} - 37,700 \text{ W/m} \times 3.902 \times 10^{-5} \text{ m} \cdot \text{K/W} = 380.9 \text{ K}. \quad <$$

**COMMENTS:** (1) The effect of the contact resistance is small.

(2) The effect of including the aluminum fins may be determined by computing  $T_i$  without the fins. In this case  $R'_{\text{tot}} = R'_c + R'_{\text{conv}}$ , where

$$R'_{\text{conv}} = \frac{1}{h2\pi r_1} = \frac{1}{100 \text{ W/m}^2 \cdot \text{K} \cdot 2\pi (0.066 \text{ m})} = 241.1 \times 10^{-4} \text{ m} \cdot \text{K/W}.$$

Hence,  $R'_{\text{tot}} = 244.1 \times 10^{-4} \text{ m} \cdot \text{K/W}$ , and

$$T_i = q'R'_{\text{tot}} + T_\infty = 37,700 \text{ W/m} \times 244.1 \times 10^{-4} \text{ m} \cdot \text{K/W} + 320 \text{ K} = 1240 \text{ K}.$$

Hence, the fins have a significant effect on reducing the cylinder temperature.

(3) The overall surface efficiency is

$$\eta_o = 1 - (A'_f / A'_t)(1 - \eta_f) = 1 - 6.78 \text{ m} / 7.00 \text{ m} (1 - 0.88) = 0.884.$$

It follows that  $q' = \eta_o h_o A'_t \theta_b = 37,700 \text{ W/m}$ , which agrees with the prescribed value.

### PROBLEM 3.161

**KNOWN:** Dimensions and materials of a finned (annular) cylinder wall. Combustion gas and ambient air conditions. Contact resistance.

**FIND:** (a) Heat rate per unit length and surface and interface temperatures, (b) Effect of increasing the fin thickness.

**SCHEMATIC:**

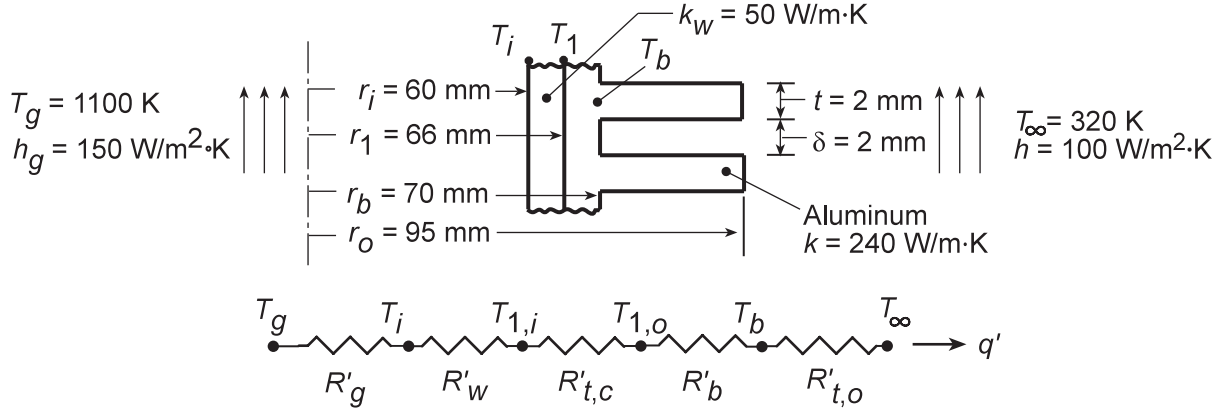

**ASSUMPTIONS:** (1) One-dimensional, steady-state conditions, (2) Constant properties, (3) Uniform  $h$  over surfaces, (4) Negligible radiation.

**ANALYSIS:** (a) The heat rate per unit length is

$$q' = \frac{T_g - T_\infty}{R'_{\text{tot}}}$$

where  $R'_{\text{tot}} = R'_g + R'_w + R'_{t,c} + R'_b + R'_{t,o}$ , and

$$R'_g = (h_g 2\pi r_i)^{-1} = (150 \text{ W/m}^2 \cdot \text{K} \times 2\pi \times 0.06 \text{ m})^{-1} = 0.0177 \text{ m} \cdot \text{K/W},$$

$$R'_w = \frac{\ln(r_1/r_i)}{2\pi k_w} = \frac{\ln(66/60)}{2\pi (50 \text{ W/m} \cdot \text{K})} = 3.03 \times 10^{-4} \text{ m} \cdot \text{K/W},$$

$$R'_{t,c} = (R'_{t,c}/2\pi r_1) = 10^{-4} \text{ m}^2 \cdot \text{K/W} / 2\pi \times 0.066 \text{ m} = 2.41 \times 10^{-4} \text{ m} \cdot \text{K/W}$$

$$R'_b = \frac{\ln(r_b/r_1)}{2\pi k} = \frac{\ln(70/66)}{2\pi \times 240 \text{ W/m} \cdot \text{K}} = 3.90 \times 10^{-5} \text{ m} \cdot \text{K/W},$$

$$R_{t,o} = (\eta_o h A'_t)^{-1},$$

$$\eta_o = 1 - \frac{N' A_f}{A'_t} (1 - \eta_f),$$

$$A_f = 2\pi (r_{oc}^2 - r_b^2)$$

$$A'_t = N' A_f + (1 - N't) 2\pi r_b$$

$$\eta_f = \frac{(2r_b/m) K_1(mr_b) I_1(mr_{oc}) - I_1(mr_b) K_1(mr_{oc})}{(r_{oc}^2 - r_b^2) I_0(mr_1) K_1(mr_{oc}) + K_0(mr_b) I_1(mr_{oc})}$$

$$r_{oc} = r_o + (t/2), \quad m = (2h/kt)^{1/2}$$

Continued...

### PROBLEM 3.161 (Cont.)

Once the heat rate is determined from the foregoing expressions, the desired interface temperatures may be obtained from

$$T_i = T_g - q'R'_g$$

$$T_{1,i} = T_g - q'(R'_g + R'_w)$$

$$T_{1,o} = T_g - q'(R'_g + R'_w + R'_{t,c})$$

$$T_b = T_g - q'(R'_g + R'_w + R'_{t,c} + R'_b)$$

For the specified conditions we obtain  $A'_t = 7.00$  m,  $\eta_f = 0.902$ ,  $\eta_o = 0.906$  and  $R'_{t,o} = 0.00158$  m·K/W. It follows that

$$q' = 39,300 \text{ W/m} \quad <$$

$$T_i = 405\text{K}, \quad T_{1,i} = 393\text{K}, \quad T_{1,o} = 384\text{K}, \quad T_b = 382\text{K} \quad <$$

(b) The *Performance Calculation, Extended Surface Model* for the *Circular Fin Array* may be used to assess the effects of fin thickness and spacing. Increasing the fin thickness to  $t = 3$  mm, with  $\delta = 2$  mm, reduces the number of fins per unit length to 200. Hence, although the fin efficiency increases ( $\eta_f = 0.930$ ), the reduction in the total surface area ( $A'_t = 5.72$  m) yields an increase in the resistance of the fin array ( $R'_{t,o} = 0.00188$  m·K/W), and hence a reduction in the heat rate ( $q' = 38,700$  W/m) and an increase in the interface temperatures ( $T_i = 415$  K,  $T_{1,i} = 404$  K,  $T_{1,o} = 394$  K, and  $T_b = 393$  K).

**COMMENTS:** Because the gas convection resistance exceeds all other resistances by at least an order of magnitude, incremental changes in  $R'_{t,o}$  will not have a significant effect on  $q'$  or the interface temperatures.



### PROBLEM 3.162

**KNOWN:** Dimensions of finned aluminum sleeve inserted over a transistor. Contact resistance between sleeve and transistor. Surface convection conditions and temperature of transistor case.

**FIND:** (a) Rate of heat transfer from sleeve and (b) Measures for increasing heat dissipation.

**SCHEMATIC:**

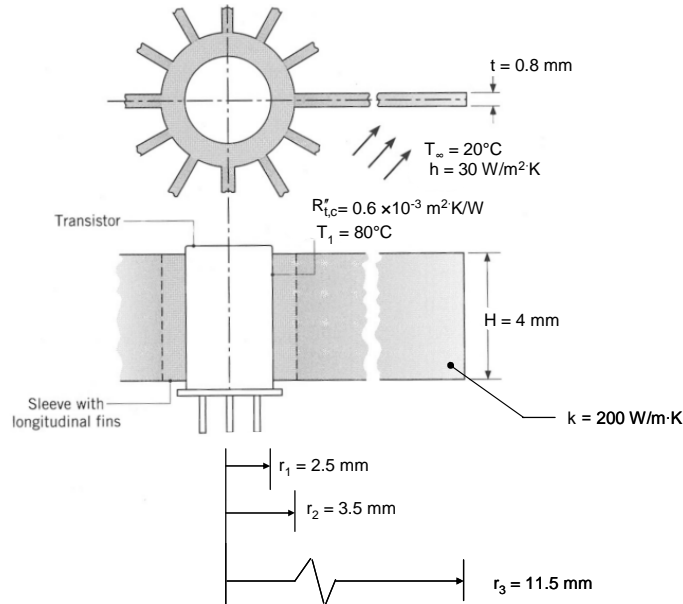

**ASSUMPTIONS:** (1) Steady-state conditions, (2) Negligible heat transfer from the top and bottom surfaces of the transistor, (3) One-dimensional radial conduction, (4) Constant properties, (5) Negligible radiation.

**ANALYSIS:**

(a) The circuit must account for the contact resistance, conduction in the sleeve, convection from the exposed base, and conduction/convection from the fins.

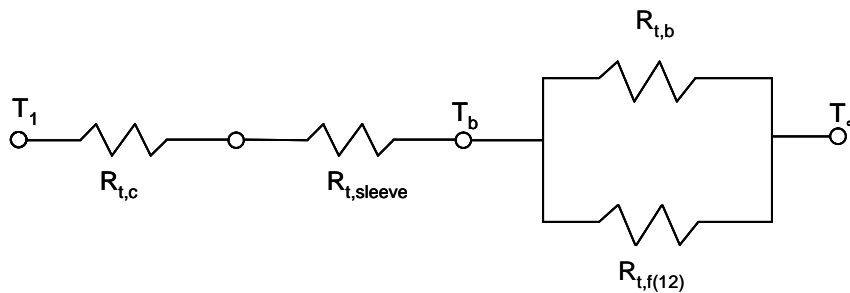

Thermal resistances for the contact joint and sleeve are

$$R_{t,c} = \frac{R''_{t,c}}{2\pi r_1 H} = \frac{0.6 \times 10^{-3} \text{ m}^2 \cdot \text{K/W}}{2\pi(0.0025 \text{ m})(0.004 \text{ m})} = 9.55 \text{ K/W}$$

$$R_{t,sleeve} = \frac{\ln(r_2/r_1)}{2\pi k H} = \frac{\ln(3.5/2.5)}{2\pi(200 \text{ W/m} \cdot \text{K})(0.004 \text{ m})} = 0.0669 \text{ K/W}$$

For a single fin,  $R_{t,f} = \theta_b / q_f$ , where from Table 3.4, with tip convection,

Continued...

**PROBLEM 3.162 (Cont.)**

$$q_f = (hPkA_c)^{1/2} \theta_b \frac{\sinh(mL) + (h/mk)\cosh(mL)}{\cosh(mL) + (h/mk)\sinh(mL)}$$

with  $P = 2(H + t) = 9.6 \text{ mm} = 0.0096 \text{ m}$  and  $A_c = t \times H = 3.2 \times 10^{-6} \text{ m}^2$ ,

$$m = \left( \frac{hP}{kA_c} \right)^{1/2} = \left( \frac{30 \text{ W/m}^2 \cdot \text{K} \times 0.0096 \text{ m}}{200 \text{ W/m} \cdot \text{K} \times 3.2 \times 10^{-6} \text{ m}^2} \right)^{1/2} = 21.2 \text{ m}^{-1}$$

$$mL = 21.2 \text{ m}^{-1} \times 0.008 \text{ m} = 0.170$$

$$\frac{h}{mk} = \frac{30 \text{ W/m}^2 \cdot \text{K}}{21.2 \text{ m}^{-1} \times 200 \text{ W/m} \cdot \text{K}} = 0.00707$$

and

$$(hPkA_c)^{1/2} = (30 \text{ W/m}^2 \cdot \text{K} \times 0.0096 \text{ m} \times 200 \text{ W/m} \cdot \text{K} \times 3.2 \times 10^{-6} \text{ m}^2)^{1/2} = 0.0136 \text{ W/K}$$

Use of Table B.1 yields, for a single fin

$$R_{t,f} = \frac{1.014 + 0.00707 \times 0.171}{0.0136 \text{ W/K} (0.171 + 0.00707 \times 1.014)} = 421 \text{ K/W}$$

Hence, for 12 fins,

$$R_{t,f(12)} = \frac{R_{t,f}}{12} = 35.1 \text{ K/W}$$

For the exposed base,

$$R_{t,b} = \frac{1}{h(2\pi r_2 - 12t)H} = \frac{1}{30 \text{ W/m}^2 \cdot \text{K} (2\pi \times 0.0035 - 12 \times 0.0008)\text{m} \times 0.004 \text{ m}} = 673 \text{ K/W}$$

With

$$R_{t,o} = \left[ (35.1)^{-1} + (673)^{-1} \right]^{-1} = 33.3 \text{ K/W}$$

it follows that

$$R_{\text{tot}} = (9.55 + 0.0669 + 33.3) \text{ K/W} = 43.0 \text{ K/W}$$

and

$$q_t = \frac{T_1 - T_\infty}{R_{\text{tot}}} = \frac{(80 - 20)^\circ\text{C}}{43.0 \text{ K/W}} = 1.40 \text{ W} <$$

(b) With  $2\pi r_2 = 0.022 \text{ m}$  and  $Nt = 0.0096 \text{ m}$ , the existing gap between fins is extremely small (0.96 mm). Hence, by increasing  $N$  and/or  $t$ , it would become even more difficult to maintain satisfactory airflow between the fins, and this option is not particularly attractive.

Because the fin efficiency for the prescribed conditions is close to unity ( $\eta_f = (hA_f R_{t,f})^{-1} = 0.992$ ), there is little advantage to replacing the aluminum with a material of higher thermal conductivity (e.g. Cu

Continued...

### PROBLEM 3.162 (Cont.)

with  $k \sim 400 \text{ W/m}\cdot\text{K}$ ). However, the large value of  $\eta_f$  suggests that significant benefit could be gained by increasing the fin length,  $L = r_3 \sqrt{h/k}$ .

It is also evident that the thermal contact resistance is large, and from Table 3.2, it's clear that a significant reduction could be effected by using indium foil or a conducting grease in the contact zone. Specifically, a reduction of  $R''_{t,c}$  from  $0.6 \times 10^{-3}$  to  $10^{-4}$  or even  $10^{-5} \text{ m}^2\cdot\text{K/W}$  is certainly feasible.

Table 1.1 suggests that, by increasing the velocity of air flowing over the fins, a larger convection coefficient may be achieved. A value of  $h = 100 \text{ W/m}^2\cdot\text{K}$  would not be unreasonable.

As options for enhancing heat transfer, we therefore enter the foregoing equations into IHT to explore the effect of parameter variations over the ranges  $8 \leq L \leq 20 \text{ mm}$ ,  $10^{-5} \leq R''_{t,c} \leq 0.6 \times 10^{-3} \text{ m}^2\cdot\text{K/W}$  and  $30 \leq h \leq 100 \text{ W/m}^2\cdot\text{K}$ . As shown below, there is a significant enhancement in heat transfer associated with reducing  $R''_{t,c}$  from  $0.6 \times 10^{-3}$  to  $10^{-4} \text{ m}^2\cdot\text{K/W}$ , for which  $R_{t,c}$  decreases from 9.55 to 1.59 K/W. At this value of  $R''_{t,c}$ , the reduction in  $R_{t,o}$  from 33.3 to 14.8 K/W which accompanies an increase in  $L$  from 8 to 20 mm becomes significant, yielding a heat rate of  $q_t = 3.65 \text{ W}$  for  $R''_{t,c} = 10^{-4} \text{ m}^2\cdot\text{K/W}$  and  $L = 20 \text{ mm}$ . However, since  $R_{t,o} \gg R_{t,c}$ , little benefit is gained by further reducing  $R''_{t,c}$  to  $10^{-5} \text{ m}^2\cdot\text{K/W}$ .

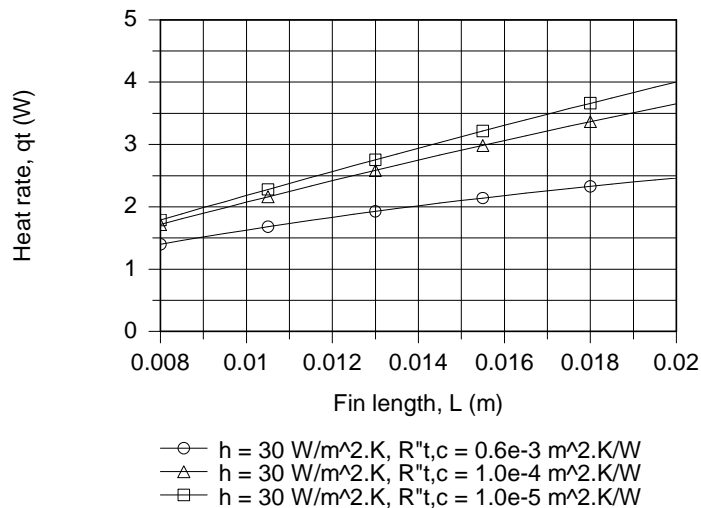

To derive benefit from a reduction in  $R''_{t,c}$  to  $10^{-5} \text{ m}^2\cdot\text{K/W}$ , an additional reduction in  $R_{t,o}$  must be made. This can be achieved by increasing  $h$ , and for  $L = 20 \text{ mm}$  and  $h = 100 \text{ W/m}^2\cdot\text{K}$ ,  $R_{t,o} = 5.0 \text{ K/W}$ . With  $R''_{t,c} = 10^{-5} \text{ m}^2\cdot\text{K/W}$ , a value of  $q_t = 11.5 \text{ W}$  may be achieved.

Continued...

### PROBLEM 3.162 (Cont.)

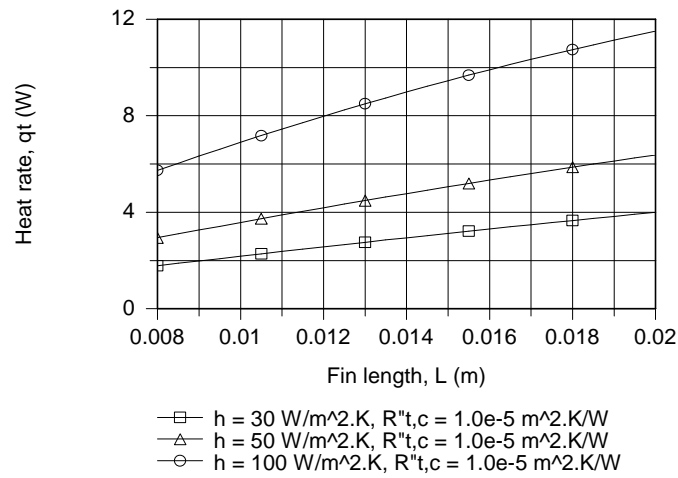

**COMMENTS:** (1) Without the finned sleeve, the convection resistance of the transistor case is  $R_{\text{tran}} = (2\pi r_1 H h)^{-1} = 531 \text{ K/W}$ . Hence there is considerable advantage to using the fins. (2) If an adiabatic fin tip is assumed,  $\tanh(mL) = 0.168$  and  $R_{t,f} = 437$ . Hence the error in the fin resistance is 4% relative to the actual convecting tip. (3) With  $\eta_f = 0.992$ , Equation 3.102 yields  $\eta_o = 0.992$ , from which it follows that  $R_{t,o} = (\eta_o h A_t)^{-1} = 33.3 \text{ K/W}$ . This result is, of course, identical to that obtained in the foregoing determination of  $R_{t,o}$ . (4) In assessing options for enhancing heat transfer, the limiting (largest) resistance(s) should be identified and efforts directed at their reduction.

### PROBLEM 3.163

**KNOWN:** Internal and external convection conditions for an internally finned tube. Fin/tube dimensions and contact resistance.

**FIND:** Heat rate per unit tube length and corresponding effects of the contact resistance, number of fins, and fin/tube material.

**SCHEMATIC:**

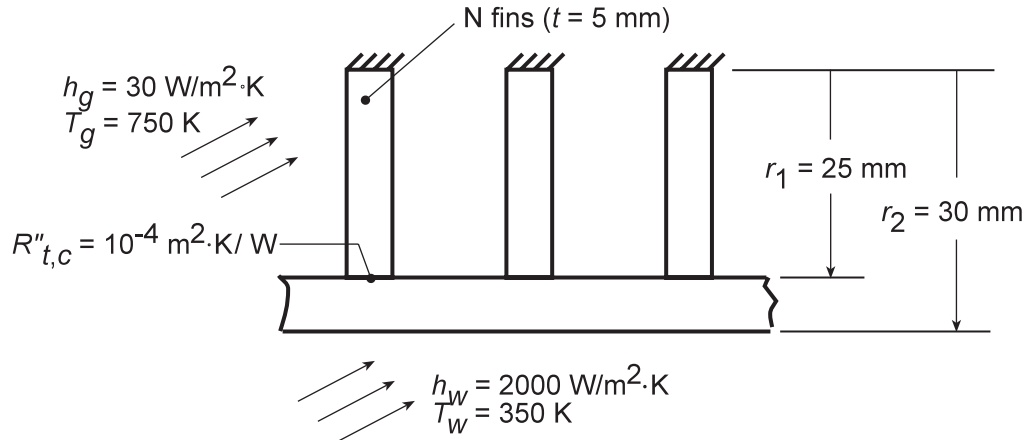

**ASSUMPTIONS:** (1) Steady-state conditions, (2) One-dimensional heat transfer, (3) Constant properties, (4) Negligible radiation, (5) Uniform convection coefficient on finned surfaces, (6) Tube wall may be unfolded and approximated as a plane surface with  $N$  straight rectangular fins.

**PROPERTIES:** Copper:  $k = 400 \text{ W/m}\cdot\text{K}$ ; St.St.:  $k = 20 \text{ W/m}\cdot\text{K}$ .

**ANALYSIS:** The heat rate per unit length may be expressed as

$$q' = \frac{T_g - T_w}{R'_{t,o(c)} + R'_{\text{cond}} + R'_{\text{conv},o}}$$

where

$$R'_{t,o(c)} = \left( \eta_{o(c)} h_g A'_t \right), \quad \eta_{o(c)} = 1 - \frac{NA'_f}{A'_t} \left( 1 - \frac{\eta_f}{C_1} \right), \quad C_1 = 1 + \eta_f h_g A'_f \left( R''_{t,c} / A'_{c,b} \right),$$

$$A'_t = NA'_f + (2\pi r_1 - Nt), \quad A'_f = 2r_1, \quad \eta_f = \tanh mr_1 / mr_1, \quad m = (2h_g / kt)^{1/2} \quad A'_{c,b} = t,$$

$$R'_{\text{cond}} = \frac{\ln(r_2 / r_1)}{2\pi k}, \quad \text{and} \quad R'_{\text{conv},o} = (2\pi r_2 h_w)^{-1}.$$

Using the IHT *Performance Calculation, Extended Surface Model* for the *Straight Fin Array*, the following results were obtained. For the *base case*,  $q' = 3857 \text{ W/m}$ , where  $R'_{t,o(c)} = 0.101 \text{ m}\cdot\text{K/W}$ ,  $R'_{\text{cond}} = 7.25 \times 10^{-5} \text{ m}\cdot\text{K/W}$  and  $R'_{\text{conv},o} = 0.00265 \text{ m}\cdot\text{K/W}$ . If the contact resistance is eliminated ( $R''_{t,c} = 0$ ),  $q' = 3922 \text{ W/m}$ , where  $R'_{t,o} = 0.0993 \text{ m}\cdot\text{K/W}$ . If the number of fins is increased to  $N = 8$ ,  $q' = 5799 \text{ W/m}$ , with  $R'_{t,o(c)} = 0.063 \text{ m}\cdot\text{K/W}$ . If the material is changed to stainless steel,  $q' = 3591 \text{ W/m}$ , with  $R'_{t,o(c)} = 0.107 \text{ m}\cdot\text{K/W}$  and  $R'_{\text{cond}} = 0.00145 \text{ m}\cdot\text{K/W}$ .

**COMMENTS:** The small reduction in  $q'$  associated with use of stainless steel is perhaps surprising, in view of the large reduction in  $k$ . However, because  $h_g$  is small, the reduction in  $k$  does not significantly reduce the fin efficiency ( $\eta_f$  changes from 0.994 to 0.891). Hence, the heat rate remains large. The influence of  $k$  would become more pronounced with increasing  $h_g$ .

### PROBLEM 3.164

**KNOWN:** Design and operating conditions of a tubular, air/water heater.

**FIND:** (a) Expressions for heat rate per unit length at inner and outer surfaces, (b) Expressions for inner and outer surface temperatures, (c) Surface heat rates and temperatures as a function of volumetric heating  $\dot{q}$  for prescribed conditions. Upper limit to  $\dot{q}$ .

**SCHEMATIC:**

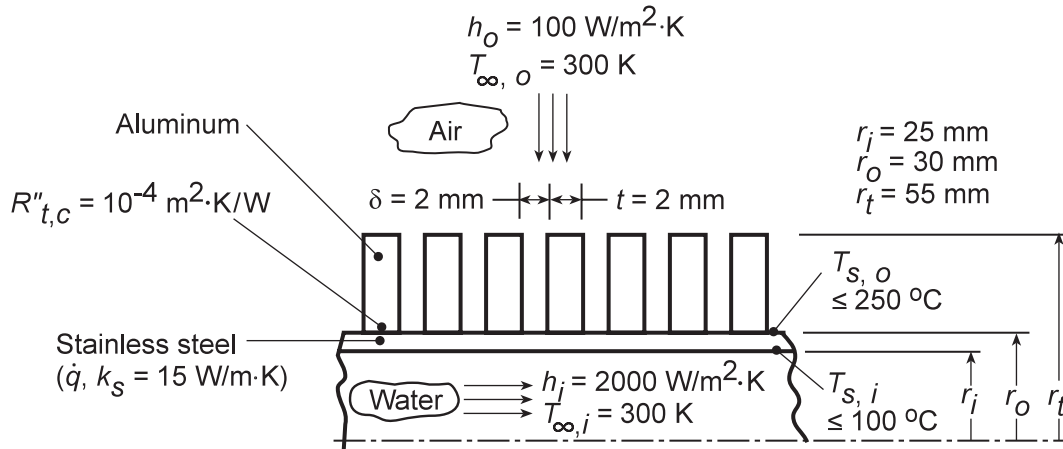

**ASSUMPTIONS:** (1) Steady-state, (2) Constant properties, (3) One-dimensional heat transfer.

**PROPERTIES:** Table A-1: Aluminum,  $T = 300 \text{ K}$ ,  $k_a = 237 \text{ W/m}\cdot\text{K}$ .

**ANALYSIS:** (a) Applying Equation C.8 to the inner and outer surfaces, it follows that

$$q'(r_i) = \dot{q}\pi r_i^2 - \frac{2\pi k_s}{\ln(r_o/r_i)} \left[ \frac{\dot{q}r_o^2}{4k_s} \left( 1 - \frac{r_i^2}{r_o^2} \right) + (T_{s,o} - T_{s,i}) \right] \quad <$$

$$q'(r_o) = \dot{q}\pi r_o^2 - \frac{2\pi k_s}{\ln(r_o/r_i)} \left[ \frac{\dot{q}r_o^2}{4k_s} \left( 1 - \frac{r_i^2}{r_o^2} \right) + (T_{s,o} - T_{s,i}) \right] \quad <$$

(b) From Equations C.16 and C.17, energy balances at the inner and outer surfaces are of the form

$$h_i(T_{\infty,i} - T_{s,i}) = \frac{\dot{q}r_i}{2} - \frac{k_s \left[ \frac{\dot{q}r_o^2}{4k_s} \left( 1 - \frac{r_i^2}{r_o^2} \right) + (T_{s,o} - T_{s,i}) \right]}{r_i \ln(r_o/r_i)} \quad <$$

$$U_o(T_{s,o} - T_{\infty,o}) = \frac{\dot{q}r_o}{2} - \frac{k_s \left[ \frac{\dot{q}r_o^2}{4k_s} \left( 1 - \frac{r_i^2}{r_o^2} \right) + (T_{s,o} - T_{s,i}) \right]}{r_o \ln(r_o/r_i)} \quad <$$

Accounting for the fin array and the contact resistance, Equation 3.109 may be used to cast the overall heat transfer coefficient  $U_o$  in the form

$$U_o = \frac{q'(r_o)}{A'_w(T_{s,o} - T_{\infty,o})} = \frac{1}{A'_w R'_{t,o(c)}} = \frac{A'_t}{A'_w} \eta_{o(c)} h_o$$

where  $\eta_{o(c)}$  is determined from Equations 3.110a,b and  $A'_w = 2\pi r_o$ .

Continued...

### PROBLEM 3.164 (Cont.)

(c) For the prescribed conditions and a representative range of  $10^7 \leq \dot{q} \leq 10^8 \text{ W/m}^3$ , use of the relations of part (b) with the capabilities of the IHT *Performance Calculation Extended Surface Model* for a *Circular Fin Array* yields the following graphical results.

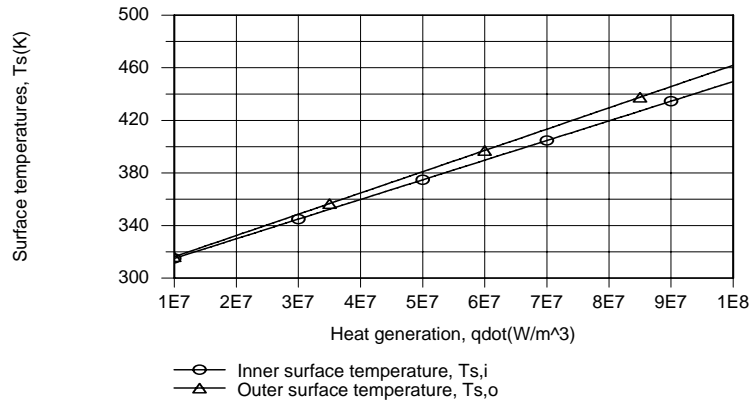

It is in this range that the upper limit of  $T_{s,i} = 373 \text{ K}$  is exceeded for  $\dot{q} = 4.9 \times 10^7 \text{ W/m}^3$ , while the corresponding value of  $T_{s,o} = 379 \text{ K}$  is well below the prescribed upper limit. The expressions of part (a) yield the following results for the surface heat rates, where heat transfer in the negative  $r$  direction corresponds to  $q'(r_1) < 0$ .

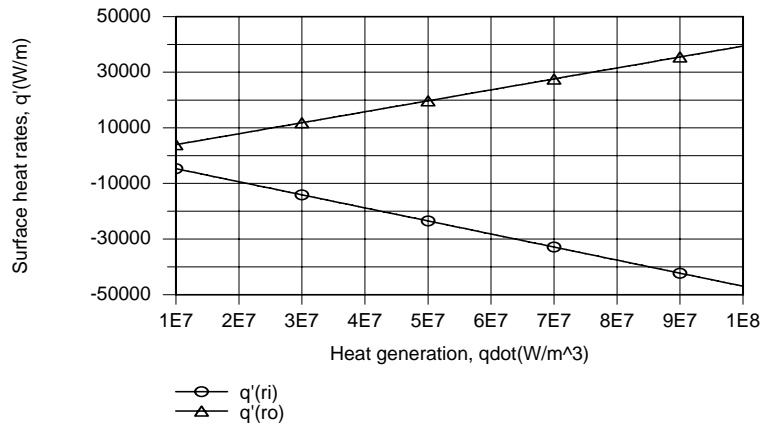

For  $\dot{q} = 4.9 \times 10^7 \text{ W/m}^3$ ,  $q'(r_1) = -2.30 \times 10^4 \text{ W/m}$  and  $q'(r_o) = 1.93 \times 10^4 \text{ W/m}$ .

**COMMENTS:** The foregoing design provides for comparable heat transfer to the air and water streams. This result is a consequence of the nearly equivalent thermal resistances associated with heat transfer from the inner and outer surfaces. Specifically,  $R'_{\text{conv},i} = (h_i 2\pi r_1)^{-1} = 0.00318 \text{ m}\cdot\text{K/W}$  is slightly smaller than  $R'_{t,o(c)} = 0.00411 \text{ m}\cdot\text{K/W}$ , in which case  $|q'(r_1)|$  is slightly larger than  $q'(r_o)$ , while  $T_{s,i}$  is slightly smaller than  $T_{s,o}$ . Note that the solution must satisfy the energy conservation requirement,

$$\pi (r_o^2 - r_1^2) \dot{q} = |q'(r_1)| + q'(r_o).$$

### PROBLEM 3.165

**KNOWN:** Dimensions and thermal conductivities of a muscle layer and a skin/fat layer. Skin emissivity and surface area. Metabolic heat generation rate and perfusion rate within the muscle layer. Core body and arterial temperatures. Blood density and specific heat. Ambient conditions.

**FIND:** Perspiration rate to maintain same skin temperature as in Example 3.12.

**SCHEMATIC:**

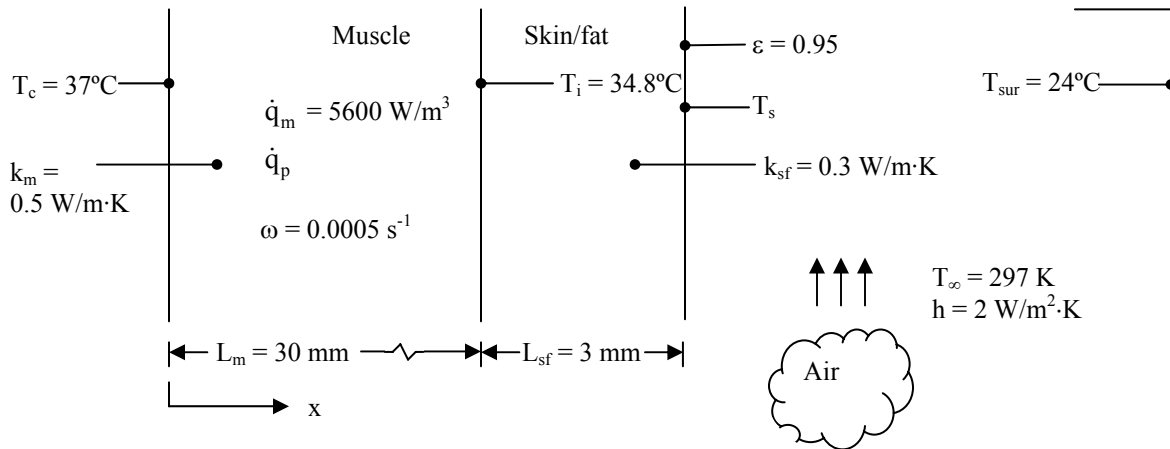

**ASSUMPTIONS:** (1) Steady-state conditions, (2) One-dimensional heat transfer through the muscle and skin/fat layers, (3) Metabolic heat generation rate, perfusion rate, arterial temperature, blood properties, and thermal conductivities are all uniform, (4) Radiation heat transfer coefficient is known from Example 1.7, (5) Solar radiation is negligible, (6) Conditions are the same everywhere on the torso, limbs, etc., (7) Perspiration on skin has a negligible effect on heat transfer from the skin to the environment, that is, it adds a negligible thermal resistance and doesn't change the emissivity.

**ANALYSIS:** First we need to find the skin temperature,  $T_s$ , for the conditions of Example 3.12, in the air environment. Both  $q$  and  $T_i$ , the interface temperature between the muscle and the skin/fat layer, are known. The rate of heat transfer across the skin/fat layer is given by

$$q = \frac{k_{sf} A (T_i - T_s)}{L_{sf}} \quad (1)$$

Thus, the skin temperature is

$$T_s = T_i - \frac{q L_{sf}}{k_{sf} A} = 34.8^\circ\text{C} - \frac{142 \text{ W} \times 0.003 \text{ m}}{0.3 \text{ W/m} \cdot \text{K} \times 1.8 \text{ m}^2} = 34.0^\circ\text{C}$$

Now the heat transfer rate will change because of the increased metabolic heat generation rate. Heat transfer in the muscle layer is governed by Equation 3.114. In Example 3.12, this equation was solved subject to specified temperature boundary conditions, and the rate at which heat leaves the muscle and enters the skin/fat layer was found to be

$$q|_{x=L_m} = -k_m A \tilde{m} \theta_c \frac{(\theta_i/\theta_c) \cosh \tilde{m} L_m - 1}{\sinh \tilde{m} L_m} \quad (2)$$

Continued...



### PROBLEM 3.165 (Cont.)

This must equal the rate at which heat is transferred across the skin/fat layer, given by Equation (1). Equating Equations 1 and 2 and solving for  $T_i$ , recalling that  $T_i$  also appears in  $\theta_i$ , yields

$$T_i = \frac{T_s \sinh \tilde{m} L_m + k_m \tilde{m} \frac{L_{sf}}{k_{sf}} \left[ \theta_c + \left( T_a + \frac{\dot{q}_m}{\omega \rho_b c_b} \right) \cosh \tilde{m} L_m \right]}{\sinh \tilde{m} L_m + k_m \tilde{m} \frac{L_{sf}}{k_{sf}} \cosh \tilde{m} L_m}$$

where

$$\tilde{m} = \sqrt{\omega \rho_b c_b / k_m} = \left[ 0.0005 \text{ s}^{-1} \times 1000 \text{ kg/m}^3 \times 3600 \text{ J/kg} \cdot \text{K} / 0.5 \text{ W/m} \cdot \text{K} \right]^{1/2} = 60 \text{ m}^{-1}$$

$$\sinh(\tilde{m} L_m) = \sinh(60 \text{ m}^{-1} \times 0.03 \text{ m}) = 2.94; \quad \cosh(\tilde{m} L_m) = \cosh(60 \text{ m}^{-1} \times 0.03 \text{ m}) = 3.11$$

$$\theta_c = T_c - T_a - \frac{\dot{q}_m}{\omega \rho_b c_b} = - \frac{\dot{q}_m}{\omega \rho_b c_b} = - \frac{5600 \text{ W/m}^3}{0.0005 \text{ s}^{-1} \times 1000 \text{ kg/m}^3 \times 3600 \text{ J/kg} \cdot \text{K}} = -3.11 \text{ K}$$

The excess temperature can be expressed in kelvins or degrees Celsius, since it is a temperature difference. Thus

$$T_i = \frac{34.0^\circ\text{C} \times 2.94 + 0.5 \text{ W/m} \cdot \text{K} \times 60 \text{ m}^{-1} \times \frac{0.003 \text{ m}}{0.3 \text{ W/m} \cdot \text{K}} \left[ -3.11^\circ\text{C} + (37^\circ\text{C} + 3.11^\circ\text{C}) \times 3.11 \right]}{2.94 + 0.5 \text{ W/m} \cdot \text{K} \times 60 \text{ m}^{-1} \times \frac{0.003 \text{ m}}{0.3 \text{ W/m} \cdot \text{K}} \times 3.11}$$

$$T_i = 35.2^\circ\text{C}$$

and again from Equation (1)

$$q = \frac{k_{sf} A (T_i - T_s)}{L_{sf}} = \frac{0.3 \text{ W/m} \cdot \text{K} \times 1.8 \text{ m}^2 (35.2^\circ\text{C} - 34.0^\circ\text{C})}{0.003 \text{ m}} = 222 \text{ W}$$

Since the skin temperature is unchanged from Example 3.12, the rate of heat transfer to the environment by convection and radiation will remain the same, and is therefore still 142 W. The difference of 80 W must be removed from the skin by perspiration, therefore

$$q_{\text{per}} = \dot{m}_{\text{per}} h_{\text{fg}} = 80 \text{ W}$$

Assuming the properties of perspiration are the same as that of water, evaluated at the skin temperature of 307 K, then from Table A.6  $h_{\text{fg}} = 2421 \text{ kJ/kg}$  and  $\rho = 994 \text{ kg/m}^3$ . Thus the volume rate of perspiration is

$$\dot{V} = \frac{\dot{m}_{\text{per}}}{\rho} = \frac{q_{\text{per}}}{\rho h_{\text{fg}}} = \frac{80 \text{ W}}{994 \text{ kg/m}^3 \times 2421 \times 10^3 \text{ J/kg}} = 3.3 \times 10^{-8} \text{ m}^3/\text{s} = 3.3 \times 10^{-5} \text{ l/s} <$$

**COMMENTS:** (1) This is a moderate rate of perspiration. In one hour, it would account for around 0.1  $\ell$ . (2) In reality, our bodies adjust in many ways to maintain core and skin temperatures. Exercise will likely cause an increase in perfusion rate near the skin surface, to locally elevate the temperature and increase the rate of heat transfer to the environment.

### PROBLEM 3.166

**KNOWN:** Dimensions and thermal conductivities of a muscle layer and a skin/fat layer. Skin emissivity and surface area. Skin temperature. Perfusion rate within the muscle layer. Core body and arterial temperatures. Blood density and specific heat. Ambient conditions.

**FIND:** Metabolic heat generation rate to maintain skin temperature at 33°C.

**SCHEMATIC:**

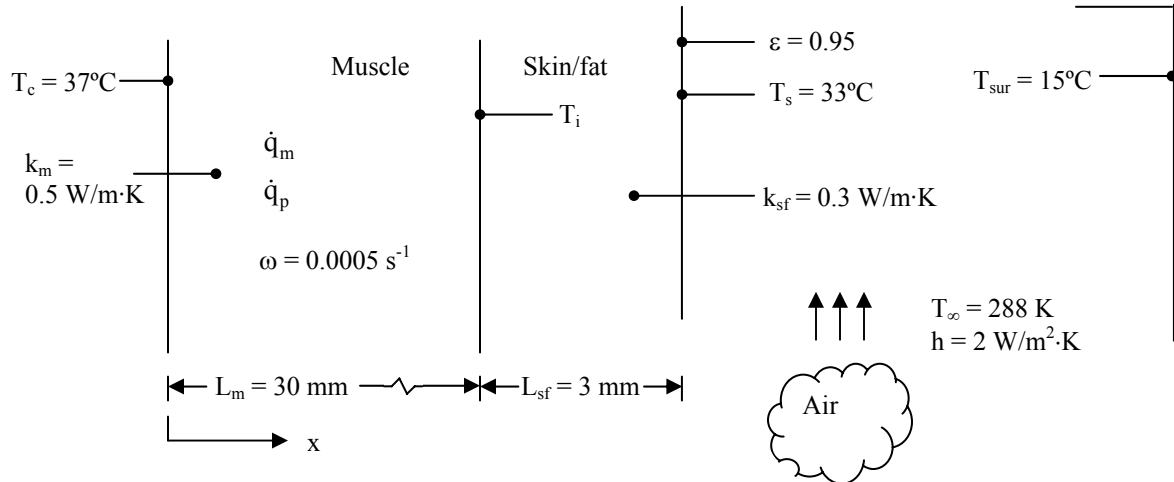

**ASSUMPTIONS:** (1) Steady-state conditions, (2) One-dimensional heat transfer through the muscle and skin/fat layers, (3) Metabolic heat generation rate, perfusion rate, arterial temperature, blood properties, and thermal conductivities are all uniform, (4) Solar radiation is negligible, (5) Conditions are the same everywhere on the torso, limbs, etc.

**ANALYSIS:** Since we know the skin temperature and environment temperature, we can find the heat loss rate from the skin surface to the environment:

$$\begin{aligned}
 q &= hA(T_s - T_\infty) + \varepsilon\sigma A(T_s^4 - T_{\text{sur}}^4) \\
 &= 2 \text{ W/m}^2 \cdot \text{K} \times 1.8 \text{ m}^2 (33 - 15)^\circ\text{C} + 0.95 \times 5.67 \times 10^{-8} \text{ W/m}^2 \cdot \text{K}^4 \times 1.8 \text{ m}^2 (306^4 - 288^4) \text{ K}^4 \\
 &= 248 \text{ W}
 \end{aligned}$$

We can then find  $T_i$ , the interface temperature between the skin/fat layer and the muscle layer, by analyzing heat transfer through the skin/fat layer:

$$T_i = T_s + \frac{qL_{\text{sf}}}{k_{\text{sf}}A} = 33^\circ\text{C} + \frac{248 \text{ W} \times 0.003 \text{ m}}{0.3 \text{ W/m} \cdot \text{K} \times 1.8 \text{ m}^2} = 34.4^\circ\text{C}$$

Heat transfer in the muscle layer is governed by Equation 3.114. In Example 3.12, this equation was solved subject to specified surface temperature boundary conditions, and the rate at which heat leaves the muscle and enters the skin/fat layer was found to be

Continued...

**PROBLEM 3.166 (Cont.)**

$$q = -k_m A \tilde{m} \frac{\theta_i \cosh \tilde{m} L_m - \theta_c}{\sinh \tilde{m} L_m}$$

This must equal the rate at which heat is transferred across the skin/fat layer, as calculated above. Inserting the definitions of  $\theta_i$  and  $\theta_c$ , we can solve for the metabolic heat generation rate:

$$\dot{q}_m = \omega \rho_b c_b \frac{\frac{q}{k_m A \tilde{m}} \sinh \tilde{m} L_m + (T_i - T_a) \cosh \tilde{m} L_m + (T_c - T_a)}{\cosh \tilde{m} L_m + 1} \quad (1)$$

where

$$\tilde{m} = \sqrt{\omega \rho_b c_b / k_m} = \left[ 0.0005 \text{ s}^{-1} \times 1000 \text{ kg/m}^3 \times 3600 \text{ J/kg} \cdot \text{K} / 0.5 \text{ W/m} \cdot \text{K} \right]^{1/2} = 60 \text{ m}^{-1}$$

$$\sinh(\tilde{m} L_m) = \sinh(60 \text{ m}^{-1} \times 0.03 \text{ m}) = 2.94 ; \quad \cosh(\tilde{m} L_m) = \cosh(60 \text{ m}^{-1} \times 0.03 \text{ m}) = 3.11$$

With  $T_c = T_a$ , Equation (1) yields

$$\begin{aligned} \dot{q}_m &= 0.0005 \text{ s}^{-1} \times 1000 \text{ kg/m}^3 \times 3600 \text{ J/kg} \cdot \text{K} \\ &\times \left[ \frac{\frac{248 \text{ W}}{0.5 \text{ W/m} \cdot \text{K} \times 1.8 \text{ m}^2 \times 60 \text{ m}^{-1}} \times 2.94 + (34.4 - 37)^\circ\text{C} \times 3.11}{3.11 + 1} \right] \\ &= 2341 \text{ W/m}^3 \end{aligned} \quad <$$

**COMMENT:** (1) Shivering can increase the metabolic heat generation rate by up to five to six times the resting metabolic rate. The value found here is approximately three times the metabolic heat generation rate given in Example 3.12, so it is well within what can be produced by shivering. (2) In the water environment, even with the original 24°C water temperature, shivering would be insufficient to maintain a comfortable skin temperature.

### PROBLEM 3.167

**KNOWN:** Dimensions and thermal conductivities of a muscle layer and a skin/fat layer. Metabolic heat generation rate and perfusion rate within the muscle layer. Arterial temperature. Blood density and specific heat. Ambient conditions.

**FIND:** Heat loss rate from body and temperature at inner surface of the skin/fat layer.

**SCHEMATIC:**

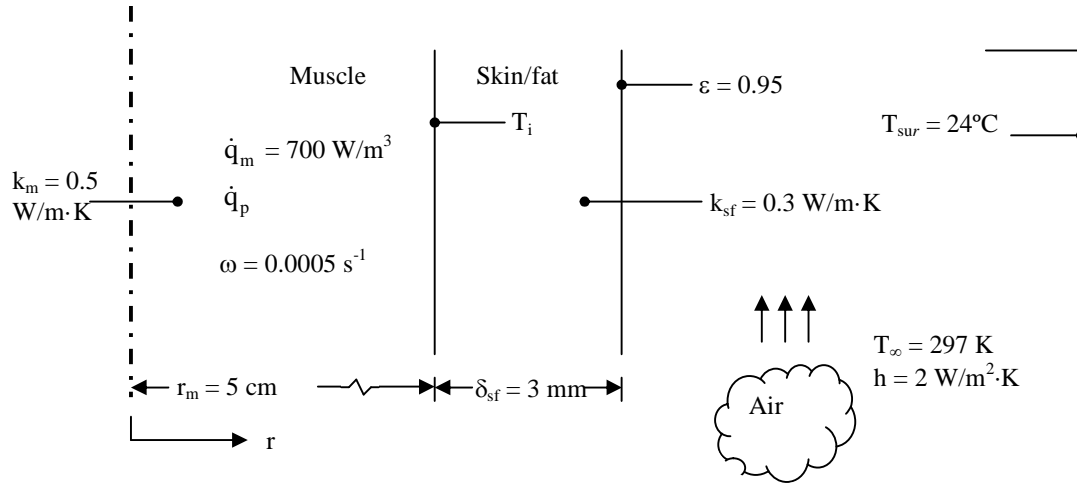

**ASSUMPTIONS:** (1) Steady-state conditions, (2) One-dimensional heat transfer through the muscle and skin/fat layers, (3) Metabolic heat generation rate, perfusion rate, arterial temperature, blood properties, and thermal conductivities are all uniform, (4) Radiation heat transfer coefficient is known from Example 1.6.

**ANALYSIS:**

(a) Conduction with heat generation is expressed in radial coordinates by Equation 3.54. With metabolic heat generation and perfusion, this becomes

$$\frac{1}{r} \frac{d}{dr} \left( r \frac{dT}{dr} \right) + \frac{\dot{q}_m + \omega \rho_b c_b (T_a - T)}{k} = 0 \quad <$$

The boundary conditions of symmetry at the centerline and specified temperature at the outer surface of the muscle are expressed as

$$\left. \frac{dT}{dr} \right|_{r=0} = 0, \quad T(r_1) = T_i \quad <$$

Defining an excess temperature,  $\theta \equiv T - T_a - \dot{q}_m / \omega \rho_b c_b$ , the differential equation becomes

$$\frac{1}{r} \frac{d}{dr} \left( r \frac{d\theta}{dr} \right) - \tilde{m}^2 \theta = 0$$

Continued...

**PROBLEM 3.167 (Cont.)**

where  $\tilde{m}^2 = \omega\rho_b c_b/k$ . The general solution to the differential equation is given in Section 3.6.4 as

$$\theta = c_1 I_0(\tilde{m}r) + c_2 K_0(\tilde{m}r)$$

Applying the boundary condition at  $r = 0$  yields

$$\left. \frac{dT}{dr} \right|_{r=0} = \left. \frac{d\theta}{dr} \right|_{r=0} = c_1 \tilde{m} I_1(0) - c_2 \tilde{m} K_1(0) = 0$$

Since  $K_1(0)$  is infinite, we must have  $c_2 = 0$ . Applying the specified temperature boundary condition at  $r = r_1$  yields

$$T(r_1) = T_i, \quad \theta(r_1) = T_i - T_a - \frac{\dot{q}_m}{\omega\rho_b c_b} \equiv \theta_i = c_1 I_0(\tilde{m}r_1)$$

Solving for  $c_1$  we now have the complete solution for  $\theta$ :

$$\theta = \theta_i \frac{I_0(\tilde{m}r)}{I_0(\tilde{m}r_1)} \quad (1)$$

(b) The heat flux at the outer surface of the muscle is given by

$$q_1'' = -k_m \left. \frac{dT}{dr} \right|_{r=r_1} = -k_m \left. \frac{d\theta}{dr} \right|_{r=r_1} = -k_m \theta_i \tilde{m} \frac{I_1(\tilde{m}r_1)}{I_0(\tilde{m}r_1)} \quad (2)$$

This must be equated to the heat flux through the skin/fat layer and into the environment. In terms of the heat transfer rate per unit length of forearm,  $q_1'$ , and the total resistance for a unit length,  $R'_{tot}$ ,

$$q_1'' = \frac{q_1'}{2\pi r_1} = \frac{1}{2\pi r_1} \frac{T_i - T_\infty}{R'_{tot}} \quad (3)$$

As in Example 3.1 and for exposure of the skin to the air,  $R'_{tot}$  accounts for conduction through the skin/fat layer in series with heat transfer by convection and radiation, which act in parallel with each other. Here the conduction resistance is for a radial geometry. Thus, it is

$$R'_{tot} = \frac{\ln(r_2/r_1)}{2\pi k_{sf}} + \frac{1}{2\pi r_2} \left( \frac{1}{h} + \frac{1}{h_r} \right)^{-1} = \frac{\ln(r_2/r_1)}{2\pi k_{sf}} + \frac{1}{2\pi r_2} \left( \frac{1}{h + h_r} \right)$$

Using the values from Example 1.7 for air,

$$R'_{tot} = \frac{\ln(0.053 \text{ m}/0.05 \text{ m})}{2 \times \pi \times 0.3 \text{ W/m} \cdot \text{K}} + \frac{1}{2 \times \pi \times 0.053 \text{ m}} \left( \frac{1}{(2 + 5.9) \text{ W/m}^2 \cdot \text{K}} \right) = 0.41 \text{ m} \cdot \text{K/W}$$

Combining Equations 2 and 3 yields

Continued...

**PROBLEM 3.167 (Cont.)**

$$-k_m \theta_i \tilde{m} \frac{I_1(\tilde{m}r_1)}{I_0(\tilde{m}r_1)} = \frac{1}{2\pi r_1} \frac{T_i - T_\infty}{R'_{\text{tot}}}$$

This expression can be solved for  $T_i$ , recalling that  $T_i$  also appears in  $\theta_i$ .

$$T_i = \frac{T_\infty I_0(\tilde{m}r_1) + k_m 2\pi r_1 \tilde{m} R'_{\text{tot}} \left( T_a + \frac{\dot{q}_m}{\omega \rho_b c_b} \right) I_1(\tilde{m}r_1)}{I_0(\tilde{m}r_1) + k_m 2\pi r_1 \tilde{m} R'_{\text{tot}} I_1(\tilde{m}r_1)}$$

where

$$\tilde{m} = \sqrt{\omega \rho_b c_b / k_m} = \left[ 0.0005 \text{ s}^{-1} \times 1000 \text{ kg/m}^3 \times 3600 \text{ J/kg} \cdot \text{K} / 0.5 \text{ W/m} \cdot \text{K} \right]^{1/2} = 60 \text{ m}^{-1}$$

$$\frac{\dot{q}_m}{\omega \rho_b c_b} = \frac{700 \text{ W/m}^3}{0.0005 \text{ s}^{-1} \times 1000 \text{ kg/m}^3 \times 3600 \text{ J/kg} \cdot \text{K}} = 0.389 \text{ K}$$

and from Table B.5

$$I_0(\tilde{m}r_1) = I_0(60 \text{ m}^{-1} \times 0.05 \text{ m}) = I_0(3) = 4.88; \quad I_1(\tilde{m}r_1) = I_1(60 \text{ m}^{-1} \times 0.05 \text{ m}) = I_1(3) = 3.95$$

Thus,

$$T_i = \frac{\left[ \begin{array}{l} 24^\circ\text{C} \times 4.88 + 0.5 \text{ W/m} \cdot \text{K} \\ \times 2 \times \pi \times 0.05 \text{ m} \times 60 \text{ m}^{-1} \\ \times 0.41 \text{ m} \cdot \text{K/W} (37 + 0.389)^\circ\text{C} \times 3.95 \end{array} \right]}{\left[ \begin{array}{l} 4.88 + 0.5 \text{ W/m} \cdot \text{K} \\ \times 2 \times \pi \times 0.05 \text{ m} \times 60 \text{ m}^{-1} \\ \times 0.41 \text{ m} \cdot \text{K/W} \times 3.95 \end{array} \right]} = 34.2^\circ\text{C} \quad <$$

(c) The maximum temperature occurs at the centerline of the forearm,  $r = 0$ , thus from Equation 1, with  $I_0(0) = 1$ ,

$$T = T_a + \frac{\dot{q}_m}{\omega \rho_b c_b} + \left( T_i - T_a - \frac{\dot{q}_m}{\omega \rho_b c_b} \right) \frac{1}{I_0(\tilde{m}r_1)} \quad <$$

$$= 37^\circ\text{C} + 0.389^\circ\text{C} + (34.2^\circ\text{C} - 37^\circ\text{C} - 0.389^\circ\text{C}) \times \frac{1}{4.88} = 36.7^\circ\text{C}$$

**COMMENTS:** (1) The maximum temperature is very close to the core body temperature of  $37^\circ\text{C}$ , as would be expected. (2) Pennes [17] conducted an experimental investigation of the temperature distribution in human forearms, by inserting thermocouples into living subjects.

### PROBLEM 3.168

**KNOWN:** Thermoelectric module properties and performance, as given in Example 3.13.

**FIND:** (a) The thermodynamic efficiency,  $\eta_{\text{therm}} \equiv P_{M=1}/q_1$ , (b) the figure of merit  $Z\bar{T}$  for one module, and the thermoelectric efficiency,  $\eta_{TE}$ . (c) the Carnot efficiency,  $\eta_{\text{Carnot}} = 1 - T_2/T_1$ , (d) the value of  $\eta_{TE}$  based upon the inappropriate use of  $T_{\infty,1}$  and  $T_{\infty,2}$  (e) the thermoelectric efficiency based upon the correct usage of  $T_1$  and  $T_2$  in Equation 3.128, and the Carnot efficiency for the case where  $h_1 = h_2 \rightarrow \infty$ .

**ASSUMPTIONS:** (1) Steady-state, one-dimensional conduction, (2) Negligible contact resistances, (3) Negligible radiation exchange and gas phase conduction inside the module, (4) Negligible conduction resistance due to metallic contacts and ceramic insulators, (5) The properties of the two semiconductors are identical and  $S_p = -S_n$ .

**ANALYSIS:** (a) From Example 3.13 the electrical power per module is  $P_{M=1} = P_{\text{tot}}/M = 46.9 \text{ W}/48 = 0.9773 \text{ W}$ . The heat input to one module may be evaluated from Equation 3 of the solution to the example problem as

$$q_1 = h_1 W^2 (T_{\infty,1} - T_1) = 40 \text{ W/m}^2 \cdot \text{K} \times (0.054 \text{ m})^2 \times [(550 + 273) \text{ K} - (173 + 273) \text{ K}] = 43.92 \text{ W}$$

Therefore, the thermodynamic efficiency is  $\eta_{\text{therm}} = P_{M=1}/q_1 = 0.9773 \text{ W}/43.92 \text{ W} = 0.022$  <

(b) From Equations 3.121 and 3.125 (or 3.122 and 3.126), we note that

$$S_{p-n} = S_{p-n,\text{eff}} / N = 0.1435 \text{ volts/K} / 100 = 0.001435 \text{ volts/K}$$

and

$$\rho_{e,s} = \frac{R_{e,\text{eff}} A_s}{2NL} = \frac{4\Omega \times 1.2 \times 10^{-5} \text{ m}^2}{2 \times 100 \times 2.5 \times 10^{-3} \text{ m}} = 9.6 \times 10^{-5} \Omega \cdot \text{m}$$

From Section 3.8,  $S = S_p = -S_n$  and for  $S_p = -S_n$ ,  $S = S_p = S_{p-n}/2 = 0.0007175 \text{ volts/K}$ ,

$$Z = \frac{S^2}{\rho_{e,s} k} = \frac{(0.0007175 \text{ volts/K})^2}{9.6 \times 10^{-5} \Omega \cdot \text{m} \times 1.2 \text{ W/m} \cdot \text{K}} = 0.004469 \text{ K}^{-1}$$

For  $T_1 = 173^\circ\text{C} + 273 \text{ K} = 446 \text{ K}$  and  $T_2 = 134^\circ\text{C} + 273 \text{ K} = 407 \text{ K}$ , as determined in the example problem, the average module temperature is  $\bar{T} = (T_1 + T_2)/2 = (446 \text{ K} + 407 \text{ K})/2 = 426.5 \text{ K}$ . Therefore, the figure of merit is

$$Z\bar{T} = 0.004469 \text{ K}^{-1} \times 426.5 \text{ K} = 1.908. \quad <$$

The thermoelectric efficiency is therefore,

Continued...

**PROBLEM 3.168 (Cont.)**

$$\eta_{TE} = \left(1 - \frac{T_2}{T_1}\right) \frac{\sqrt{1 + Z\bar{T}} - 1}{\sqrt{1 + Z\bar{T}} + T_2/T_1} = \left(1 - \frac{407 \text{ K}}{446 \text{ K}}\right) \frac{\sqrt{1 + 1.908\text{K}^{-1}} - 1}{\sqrt{1 + 1.908\text{K}^{-1}} + 407 \text{ K}/446 \text{ K}} = 0.024 \quad <$$

We note that the thermodynamic efficiency is less than the thermoelectric efficiency based on the figure of merit and the surface temperatures of the module. The thermoelectric efficiency is the maximum possible efficiency for the case when the load resistance is optimized.

(c) The Carnot efficiency is  $\eta_{\text{Carnot}} = 1 - 407\text{K}/446 \text{ K} = 0.087$  <

(d) The value of  $\eta_{TE}$  based upon  $T_{\infty,1} = 550^\circ\text{C} + 273 \text{ K} = 823 \text{ K}$ ,  $T_{\infty,2} = 105^\circ\text{C} + 273 \text{ K} = 378 \text{ K}$ , and  $Z\bar{T} = 0.004469 \text{ K}^{-1} \times 600.5 \text{ K} = 2.684$  is

$$\eta_{TE} = \left(1 - \frac{T_{\infty,2}}{T_{\infty,1}}\right) \frac{\sqrt{1 + Z\bar{T}} - 1}{\sqrt{1 + Z\bar{T}} + T_{\infty,2}/T_{\infty,1}} = \left(1 - \frac{378 \text{ K}}{823 \text{ K}}\right) \frac{\sqrt{1 + 2.684} - 1}{\sqrt{1 + 2.684} + 378 \text{ K}/823 \text{ K}} = 0.21 \quad <$$

(e) For  $h_1 = h_2 \rightarrow \infty$ , the surface temperatures of the module are  $T_1 = T_{\infty,1} = 823 \text{ K}$  and  $T_2 = T_{\infty,2} = 378 \text{ K}$ , respectively. Therefore, from part (d)  $\eta_{TE} = 0.21$ . The Carnot efficiency is  $\eta_{\text{Carnot}} = 1 - 378 \text{ K}/823 \text{ K} = 0.54$ . <

**COMMENTS:** (1) The conversion efficiency for the thermoelectric modules of Example 3.13 is quite small, approximately 2%. (2) The conversion efficiency can be increased by an order of magnitude (to 21%) by utilizing thermal management approaches that will increase the temperature difference across the module. (c) The incorrect usage of  $T_{\infty,1}$  and  $T_{\infty,2}$  in the expression for the thermoelectric efficiency as in part (d) provides an efficiency (21%) that far exceeds the Carnot efficiency of 8.7% found in part (c). Hence, use of the incorrect temperatures in the thermoelectric efficiency expression can lead to grossly exaggerated levels of thermodynamic performance that violate the second law of thermodynamics. Reporting the efficiency of a thermoelectric module or thermoelectric material based upon fluid (or surrounding) temperatures is meaningless.



### PROBLEM 3.169

**KNOWN:** Dimensions of thermoelectric module and heat sinks. Convection conditions, heat sink thermal conductivity, thermoelectric module performance parameters, load electrical resistance. Contact resistance between thermoelectric module and heat sinks.

**FIND:** (a) Sketch of the equivalent thermal circuit and electrical power generated without the heat sinks. (b) Sketch of the equivalent thermal circuit and electrical power generated with the heat sinks.

**SCHEMATIC:**

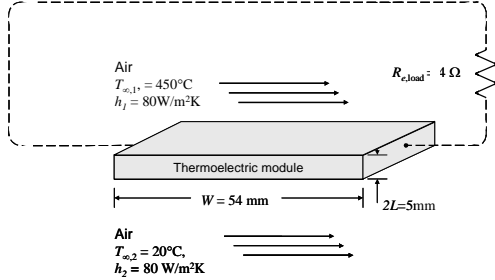

(a)

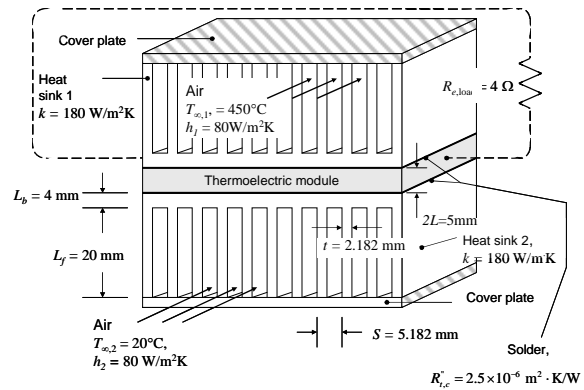

(b)

**ASSUMPTIONS:** (1) Steady-state, one-dimensional conduction, (2) Constant properties, (3) Negligible radiation, (4) Adiabatic fin tips for part (b), (5) Convection coefficients same in parts (a) and (b) and the same on the sides of the fin arrays.

**ANALYSIS:** (a) Without the heat sinks, the equivalent thermal circuit is shown in Figure 3.24b as replicated below.

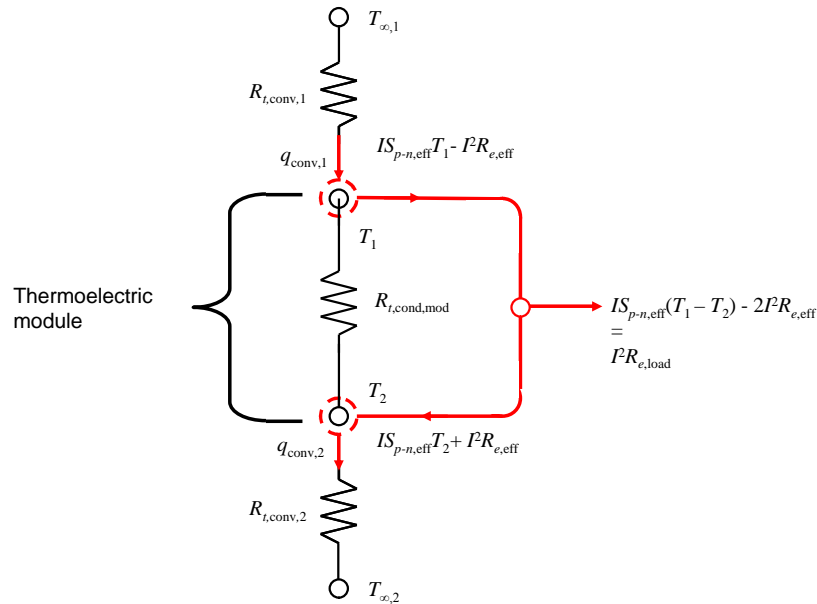

<

Continued...

### PROBLEM 3.169 (Cont.)

The analysis can proceed as in Example 3.13. The conduction resistance of one module is the same as in the example, namely

$$R_{t,\text{cond,mod}} = \frac{L}{NA_{c,s}k_s} = \frac{2.5 \times 10^{-3} \text{ m}}{100 \times 1.2 \times 10^{-5} \text{ m}^2 \times 1.2 \text{ W/m} \cdot \text{K}} = 1.736 \text{ K/W}$$

From Equations 3.125 and 3.126,

$$q_1 = \frac{1}{R_{t,\text{cond,mod}}} (T_1 - T_2) + IS_{p-n,\text{eff}} T_1 - I^2 R_{e,\text{eff}} = \frac{(T_1 - T_2)}{1.736 \text{ K/W}} + I \times 0.1435 \text{ V/K} \times T_1 - I^2 \times 4 \Omega \quad (1)$$

$$q_2 = \frac{1}{R_{t,\text{cond,mod}}} (T_1 - T_2) + IS_{p-n,\text{eff}} T_2 + I^2 R_{e,\text{eff}} = \frac{(T_1 - T_2)}{1.736 \text{ K/W}} + I \times 0.1435 \text{ V/K} \times T_2 + I^2 \times 4 \Omega \quad (2)$$

Newton's law of cooling may be written at each surface as

$$q_1 = h_1 W^2 (T_{\infty,1} - T_1) = 80 \text{ W/m}^2 \cdot \text{K} \times (0.054 \text{ m})^2 \times [(450 + 273) \text{ K} - T_1] \quad (3)$$

$$q_2 = h_2 W^2 (T_2 - T_{\infty,2}) = 80 \text{ W/m}^2 \cdot \text{K} \times (0.054 \text{ m})^2 \times [T_2 - (20 + 273) \text{ K}] \quad (4)$$

The electric power produced by a single module,  $P_N$ , is equal to the electric power dissipated in the load resistance. Equating the expression for  $P_N$  from Equation 3.127 to the electric power dissipated in the load gives

$$\begin{aligned} P_N &= IS_{p-n,\text{eff}} (T_1 - T_2) - 2I^2 R_{e,\text{eff}} = I^2 R_{e,\text{load}} \\ I \times 0.1435 \text{ V/K} \times (T_1 - T_2) - 2I^2 \times 4 \Omega &= I^2 \times 4 \Omega \end{aligned} \quad (5)$$

Equations 1 through 5 may be solved simultaneously, for example using IHT, to yield  $I = 0.38 \text{ A}$ , and

$$P_N = I^2 R_{e,\text{load}} = (0.38 \text{ A})^2 \times 4 \Omega = 0.59 \text{ W} \quad \leftarrow$$

(b) The thermal circuit associated with the thermoelectric module is unchanged, but each convection resistance must be replaced with the total thermal resistance,  $R_{\text{tot}}$ , associated with the contact resistance, fin array base, and overall resistance of the fin array, as shown below. Also,  $q_{\text{conv},1}$  and  $q_{\text{conv},2}$  have been replaced with the more general terms  $q_1$  and  $q_2$ .

Continued...

**PROBLEM 3.169 (Cont.)**

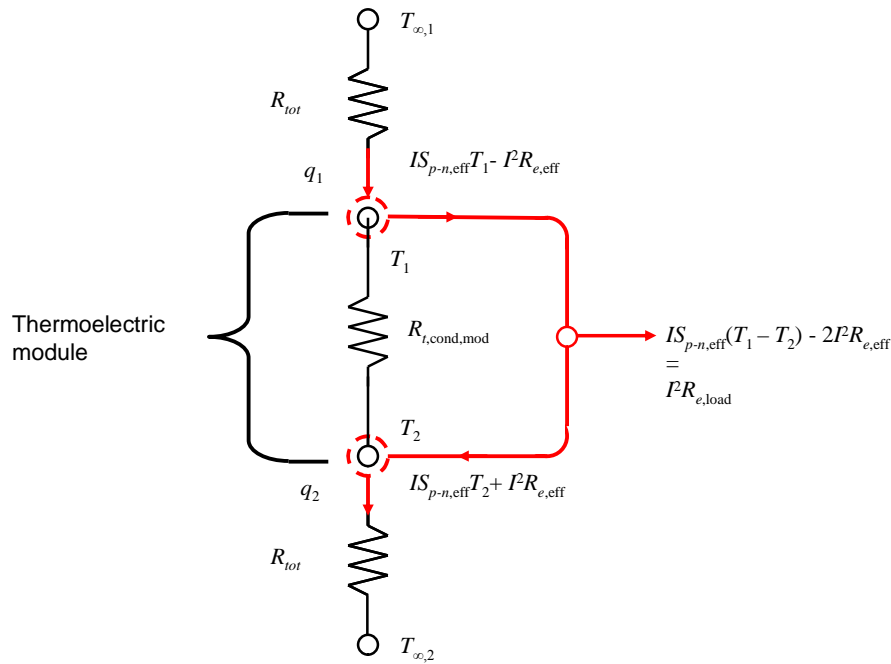

The total thermal resistance is given by

$$R_{\text{tot}} = \frac{R_{t,c}''}{W^2} + R_{\text{base}} + R_{t,o} = \frac{R_{t,c}''}{W^2} + \frac{L_b}{kW^2} + \frac{1}{\eta_o h A_t}$$

where Equation 3.108 has been used to express the overall fin resistance. From Equations 3.104, 3.107, and 3.94,

$$\eta_o A_t = A_b + NA_f \eta_f = (N-1)W(S-t) + 2NWL_f \frac{\tanh mL_f}{mL_f}$$

where

$$m = \sqrt{hP / kA_c} = \sqrt{2h / kt} = \sqrt{2 \times 80 \text{ W/m}^2 \cdot \text{K} / (180 \text{ W/m} \cdot \text{K} \times 0.002182 \text{ m})} = 20.2 \text{ m}^{-1}$$

Thus,

$$\eta_o A_t = 10 \times 0.054 \text{ m} \times 0.003 \text{ m} + 2 \times 11 \times 0.054 \text{ m} \times 0.020 \text{ m} \frac{\tanh(20.2 \text{ m}^{-1} \times 0.02 \text{ m})}{20.2 \text{ m}^{-1} \times 0.02 \text{ m}} = 0.0242 \text{ m}^2$$

The total thermal resistance is then

$$R_{\text{tot}} = \frac{2.5 \times 10^{-6} \text{ K/W}}{(0.054 \text{ m})^2} + \frac{0.004 \text{ m}}{180 \text{ W/m} \cdot \text{K} (0.054 \text{ m})^2} + \frac{1}{0.0242 \text{ m}^2 \times 80 \text{ W/m}^2 \cdot \text{K}} = 0.526 \text{ K/W}$$

Continued...

### PROBLEM 3.169 (Cont.)

The system of equations from part (a) applies here, except that Equations 3 and 4 are replaced by the revised versions

$$q_1 = \frac{T_{\infty,1} - T_1}{R_{\text{tot}}} = \frac{(450 + 273)\text{K} - T_1}{0.526 \text{ K/W}} \quad (3r)$$

$$q_2 = \frac{T_2 - T_{\infty,2}}{R_{\text{tot}}} = \frac{T_2 - (20 + 273)\text{K}}{0.526 \text{ K/W}} \quad (4r)$$

Equations 1, 2, 3r, 4r, and 5 may be solved simultaneously to yield  $I = 2.04 \text{ A}$ , and

$$P_N = I^2 R_{e,\text{load}} = (2.04 \text{ A})^2 \times 4 \Omega = 16.7 \text{ W} \quad <$$

This is 28 times larger than the result of part (a). <

**COMMENTS:** By adding the two heat sinks to the thermoelectric module, the power produced by the module increases by a factor of 28. Not only does the power depend on the semiconductor properties of the thermoelectric material, but also strongly on the thermal management of the module through, as in this problem, addition of heat sinks.

### PROBLEM 3.170

**KNOWN:** Dimensions of thermoelectric module. Convection conditions, thermoelectric module performance parameters, load electrical resistance, contact resistance between thermoelectric module and stove surface, emissivity of the exposed surface of the thermoelectric module, temperature of surroundings.

**FIND:** Sketch of the equivalent thermal circuit and electrical power generated by the module.

**SCHEMATIC:**

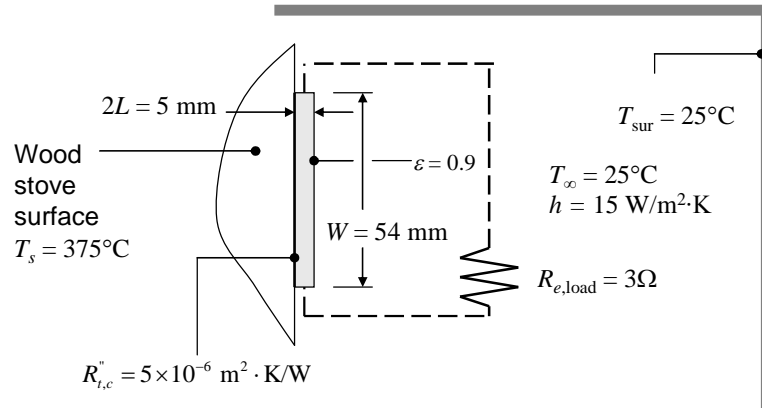

**ASSUMPTIONS:** (1) Steady-state, one-dimensional conduction, (2) Constant properties, (3) Large surroundings.

**ANALYSIS:** The portion of the equivalent thermal circuit that describes the thermoelectric module is the same as shown in Figure 3.24b. However, the external thermal resistances are different. The high temperature side of the TEM is exposed to the stove surface through a contact resistance,  $R_{t,c}$ . The low temperature side exchanges heat with the surroundings through radiation and convection. Since  $T_{\infty} = T_{sur}$ , the radiation and convection thermal resistances can be combined into a single resistance,  $R_{rad,conv}$ , as shown below. Also,  $q_{conv,1}$  and  $q_{conv,2}$  have been replaced with the more general terms  $q_1$  and  $q_2$ .

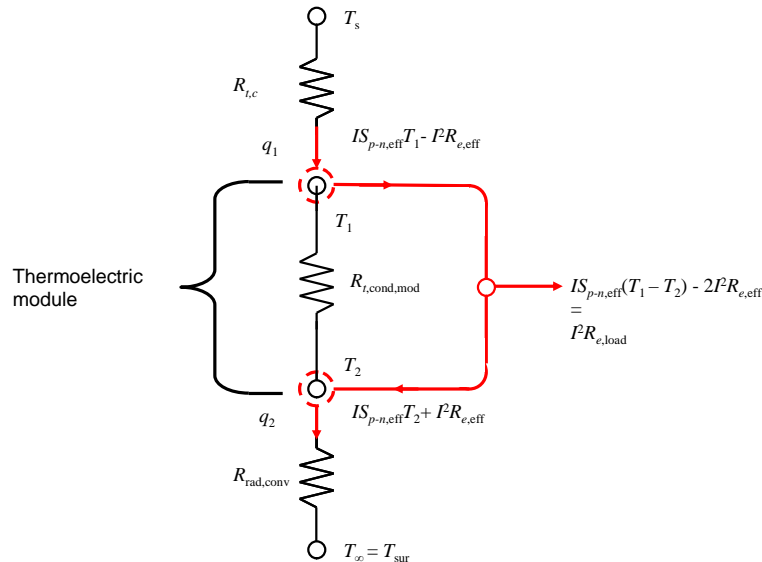

Continued...

### PROBLEM 3.170 (Cont.)

The two external resistances can be calculated as follows:

$$R_{t,c} = R_{t,c}'' / W^2 = 5 \times 10^{-6} \text{ m}^2 \cdot \text{K/W} / (0.054 \text{ m})^2 = 1.71 \times 10^{-3} \text{ K/W}$$

$$R_{\text{rad,conv}} = 1 / [(h_{\text{conv}} + h_r)W^2]$$

$$h_r = \varepsilon\sigma(T_2 + T_{\text{sur}})(T_2^2 + T_{\text{sur}}^2) \quad (1)$$

The radiation heat transfer coefficient,  $h_r$ , depends on the unknown TEM surface temperature,  $T_2$ . This can be left as an unknown in solving the simultaneous equations.

The analysis proceeds as in Example 3.13. The conduction resistance of one module is the same as in the example, namely

$$R_{t,\text{cond,mod}} = \frac{L}{NA_{c,s}k_s} = \frac{2.5 \times 10^{-3} \text{ m}}{100 \times 1.2 \times 10^{-5} \text{ m}^2 \times 1.2 \text{ W/m} \cdot \text{K}} = 1.736 \text{ K/W}$$

From Equations 3.125 and 3.126,

$$q_1 = \frac{1}{R_{t,\text{cond,mod}}}(T_1 - T_2) + IS_{p-n,\text{eff}}T_1 - I^2R_{e,\text{eff}} = \frac{(T_1 - T_2)}{1.736 \text{ K/W}} + I \times 0.1435 \text{ V/K} \times T_1 - I^2 \times 4 \Omega \quad (2)$$

$$q_2 = \frac{1}{R_{t,\text{cond,mod}}}(T_1 - T_2) + IS_{p-n,\text{eff}}T_2 + I^2R_{e,\text{eff}} = \frac{(T_1 - T_2)}{1.736 \text{ K/W}} + I \times 0.1435 \text{ V/K} \times T_2 + I^2 \times 4 \Omega \quad (3)$$

Additional relationships can be written by considering heat transfer through the external resistances.

$$q_1 = (T_s - T_1) / R_{t,c} = [(375 + 273) \text{ K} - T_1] / 1.71 \times 10^{-3} \text{ K/W} \quad (4)$$

$$\begin{aligned} q_2 &= (T_2 - T_\infty) / R_{\text{rad,conv}} = (T_2 - T_\infty)(h + h_r)W^2 \\ &= [T_2 - (25 + 273) \text{ K}] \times (15 \text{ W/m}^2 \cdot \text{K} + h_r) \times (0.054 \text{ m})^2 \end{aligned} \quad (5)$$

The electric power produced by the single module,  $P_N$ , is equal to the electric power dissipated in the load resistance. Equating the expression for  $P_N$  from Equation 3.127 to the electric power dissipated in the load gives

$$P_N = IS_{p-n,\text{eff}}(T_1 - T_2) - 2I^2R_{e,\text{eff}} = I^2R_{e,\text{load}}$$

$$I \times 0.1435 \text{ V/K} \times (T_1 - T_2) - 2I^2 \times 4 \Omega = I^2 \times 3 \Omega \quad (6)$$

Continued...

### PROBLEM 3.170 (Cont.)

Equations 1 through 6 may be solved simultaneously, for example using IHT, to yield  $I = 0.27$  A, and

$$P_N = I^2 R_{e,\text{load}} = (0.27 \text{ A})^2 \times 3 \Omega = 0.22 \text{ W} \quad <$$

**COMMENTS:** (1) Radiation is significant. If radiation heat transfer were neglected, the electrical power output would be decreased to 0.036 W. (2) The electrical power output is quite low. The power output could be raised by increasing the temperature difference across the module. For example, the electrical power could be used to rotate a small fan to increase the value of the heat transfer coefficient. If  $h$  were to increase to  $30 \text{ W/m}^2\cdot\text{K}$ , for example, the electrical power would increase to 0.40 W. A tradeoff exists between the extra power provided by the fan and the power needed to operate the fan.

### PROBLEM 3.171

**KNOWN:** Thermal energy generation rate. Dimensions of thermoelectric modules and total number of modules. Thermoelectric module performance parameters, load electrical resistance, emissivity of the exposed surface of the thermoelectric modules, deep space temperature.

**FIND:** Electrical power generated by the device. Surface temperatures of the modules.

**SCHEMATIC:**

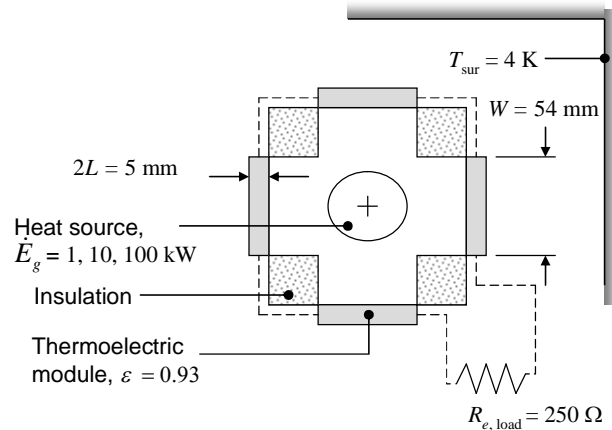

**ASSUMPTIONS:** (1) Steady-state, one-dimensional conduction, (2) Constant properties, (3) Large surroundings.

**ANALYSIS:** The portion of the equivalent thermal circuit that describes the thermoelectric module is the same as shown in Figure 3.24b. The energy generated in the uranium is known, and under steady-state conditions  $q_1 = \dot{E}_g / M$ . As a consequence, knowledge of the thermal resistance between the uranium and the inner surface of the TEMs is not needed. The low temperature side of the TEMs exchanges heat with the surroundings through radiation. Thus, the equivalent thermal circuit is as shown below. Note that  $q_{\text{conv},1}$  and  $q_{\text{conv},2}$  have been replaced with the more general terms  $q_1$  and  $q_2$ .

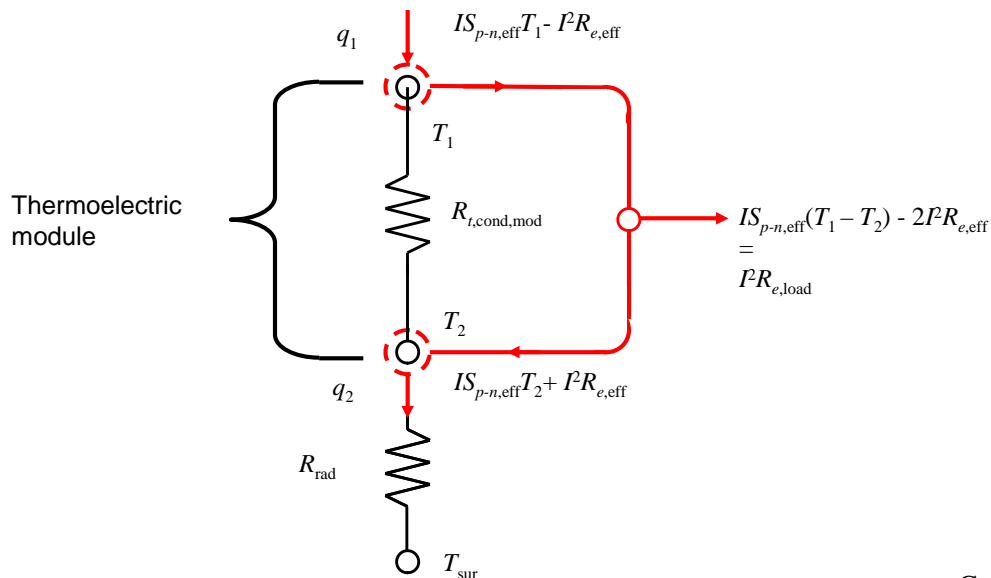

Continued...



### PROBLEM 3.171 (Cont.)

The analysis proceeds as in Example 3.13. The conduction resistance of one module is the same as in the example, namely

$$R_{t,\text{cond,mod}} = \frac{L}{NA_{c,s}k_s} = \frac{2.5 \times 10^{-3} \text{ m}}{100 \times 1.2 \times 10^{-5} \text{ m}^2 \times 1.2 \text{ W/m} \cdot \text{K}} = 1.736 \text{ K/W}$$

From Equations 3.125 and 3.126,

$$q_1 = \frac{1}{R_{t,\text{cond,mod}}} (T_1 - T_2) + IS_{p-n,\text{eff}} T_1 - I^2 R_{e,\text{eff}} = \frac{(T_1 - T_2)}{1.736 \text{ K/W}} + I \times 0.1435 \text{ V/K} \times T_1 - I^2 \times 4 \Omega \quad (1)$$

$$q_2 = \frac{1}{R_{t,\text{cond,mod}}} (T_1 - T_2) + IS_{p-n,\text{eff}} T_2 + I^2 R_{e,\text{eff}} = \frac{(T_1 - T_2)}{1.736 \text{ K/W}} + I \times 0.1435 \text{ V/K} \times T_2 + I^2 \times 4 \Omega \quad (2)$$

An additional relationship can be written by considering heat transfer by radiation to deep space.

$$q_2 = h_r W^2 (T_2 - T_{\text{sur}}) = h_r \times (0.054 \text{ m})^2 \times (T_2 - 4 \text{ K}) \quad (3)$$

where

$$h_r = \varepsilon \sigma (T_2 + T_{\text{sur}})(T_2^2 + T_{\text{sur}}^2) = 0.93 \times 5.67 \times 10^{-8} \text{ W/m}^2 \cdot \text{K} \times (T_2 + 4 \text{ K}) \times (T_2^2 + (4 \text{ K})^2) \quad (4)$$

The radiation heat transfer coefficient,  $h_r$ , depends on the unknown TEM surface temperature,  $T_2$ . This can be left as an unknown in solving the simultaneous equations.

The electric power produced by all 80 modules,  $P_{\text{tot}}$ , is equal to the electric power dissipated in the load resistance. Making use of Equation 3.127 and equating the total electrical power generated in the  $M$  modules to the electric power dissipated in the load gives

$$\begin{aligned} P_{\text{tot}} &= MP_N = I^2 R_{e,\text{load}} \\ M \left[ IS_{p-n,\text{eff}} (T_1 - T_2) - 2I^2 R_{e,\text{eff}} \right] &= I^2 R_{e,\text{load}} \\ 80 \left[ I \times 0.1435 \text{ V/K} \times (T_1 - T_2) - 2I^2 \times 4 \Omega \right] &= I^2 \times 250 \Omega \end{aligned} \quad (5)$$

With  $q_1$  known from  $q_1 = \dot{E}_g / M$ , Equations 1 through 5 can be solved for the five unknowns,  $T_1$ ,  $T_2$ ,  $I$ ,  $q_2$ , and  $h_r$ . Solving the equations numerically using IHT yields the following results for the three different values of  $\dot{E}_g$ :

Continued...

**PROBLEM 3.171 (Cont.)**

$\dot{E}_g$ (kW)	$I$ (A)	$P_{\text{tot}}$ (W)	$T_2$ (K)	$\eta = P_N/q_1$
1	0.10	2.63	534	0.0026
10	0.67	114	947	0.011
100	3.99	3990	1671	0.040

<

**COMMENTS:** (1) The temperature for the highest thermal energy generation rate is unacceptably high. (2) The electrical energy generated by the device is relatively high, but the efficiency is quite low. The efficiency increases as a function of the thermal generation rate because of larger temperature differences across the module, which are  $\Delta T = 8, 52,$  and  $310$  K for the low, medium and high energy generation rates. (3) Numerical solution of the equations requires a good initial guess. One can be obtained by assuming that the current is zero, resulting in  $q_1 = q_2$  and enabling direct calculation of the temperatures due to conduction across the TEM and radiation to the surroundings. (4) In this application, thermal generation can occur continuously for many years, providing reliable electrical power to the satellite over its lifetime. (5) What steps could be taken to increase the electrical power generated for each thermal energy generation rate?

### PROBLEM 3.172

**KNOWN:** Net radiation heat flux on absorber plate. Dimensions of thermoelectric modules, total number of modules, spacing of module rows. Thermoelectric module performance parameters, load electrical resistance. Water temperature and heat transfer coefficient.

**FIND:** Electrical power produced by one row of thermoelectric modules. Heat transfer rate to water.

**SCHEMATIC:**

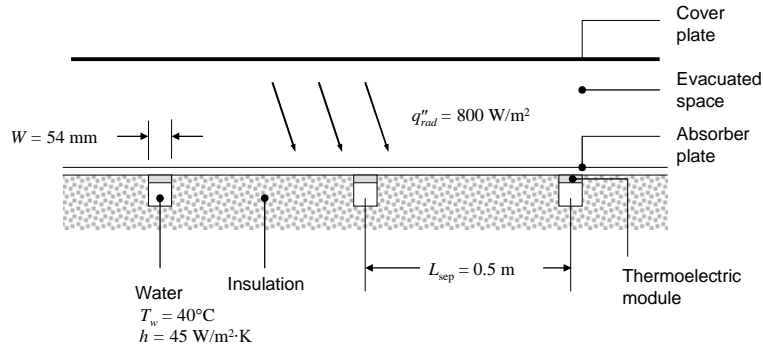

**ASSUMPTIONS:** (1) Steady-state conditions, (2) Constant properties, (3) Negligible losses through insulation, (4) Negligible losses by convection at absorber plate surface, (5) High thermal conductivity tube wall creates uniform temperature around the tube perimeter, (6) Tubes of square cross section. (7) Water temperature remains at 40°C.

**ANALYSIS:** The heat absorbed in the absorber plate is known, and under steady-state conditions all of this heat must conduct along the absorber plate and enter the thermoelectric modules, so that the heat associated with one module is given by

$$q_1 = q''_{\text{rad}} L_{\text{sep}} W = 800 \text{ W/m}^2 \times 0.5 \text{ m} \times 0.054 \text{ m} = 21.6 \text{ W}$$

The portion of the equivalent thermal circuit that describes the thermoelectric module is the same as shown in Figure 3.24b, see below. The low temperature side of the TEMs exchanges heat with the water through convection. Note that  $q_{\text{conv},1}$  has been replaced with the more general term  $q_1$ .

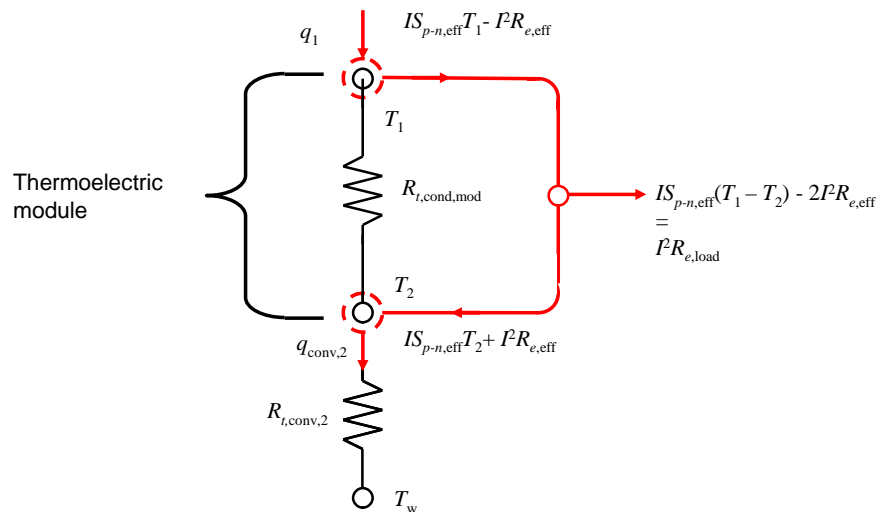

Continued...

### PROBLEM 3.172 (Cont.)

The analysis proceeds as in Example 3.13. The conduction resistance of one module is the same as in the example, namely

$$R_{t,\text{cond,mod}} = \frac{L}{NA_{c,s}k_s} = \frac{2.5 \times 10^{-3} \text{ m}}{100 \times 1.2 \times 10^{-5} \text{ m}^2 \times 1.2 \text{ W/m} \cdot \text{K}} = 1.736 \text{ K/W}$$

From Equations 3.125 and 3.126,

$$q_1 = \frac{1}{R_{t,\text{cond,mod}}} (T_1 - T_2) + IS_{p-n,\text{eff}} T_1 - I^2 R_{e,\text{eff}} = \frac{(T_1 - T_2)}{1.736 \text{ K/W}} + I \times 0.1435 \text{ V/K} \times T_1 - I^2 \times 4 \Omega \quad (1)$$

$$q_2 = \frac{1}{R_{t,\text{cond,mod}}} (T_1 - T_2) + IS_{p-n,\text{eff}} T_2 + I^2 R_{e,\text{eff}} = \frac{(T_1 - T_2)}{1.736 \text{ K/W}} + I \times 0.1435 \text{ V/K} \times T_2 + I^2 \times 4 \Omega \quad (2)$$

An additional relationship can be written by considering heat transfer by convection to the water. It is assumed that heat exiting the thermoelectric modules conducts around the perimeter of the square tube wall and enters the water uniformly over the entire tube wall area,

$$q_2 = 4hW^2(T_2 - T_w) = 4 \times 45 \text{ W/m}^2 \cdot \text{K} \times (0.054 \text{ m})^2 \times (T_2 - (40 + 273) \text{ K}) \quad (3)$$

The electric power produced by all  $M = 20$  modules,  $P_{\text{tot}}$ , is equal to the electric power dissipated in the load resistance. Making use of Equation 3.127, and equating the total electrical power generated in the  $M$  modules to the electric power dissipated in the load gives

$$\begin{aligned} P_{\text{tot}} &= MP_N = I^2 R_{e,\text{load}} \\ M \left[ IS_{p-n,\text{eff}} (T_1 - T_2) - 2I^2 R_{e,\text{eff}} \right] &= I^2 R_{e,\text{load}} \\ 20 \left[ I \times 0.1435 \text{ V/K} \times (T_1 - T_2) - 2I^2 \times 4 \Omega \right] &= I^2 \times 60 \Omega \end{aligned} \quad (4)$$

With  $q_1$  known, Equations 1 through 4 can be solved for the four unknowns,  $T_1$ ,  $T_2$ ,  $I$ , and  $q_2$ . Then  $P_{\text{tot}}$  can be found from  $P_{\text{tot}} = I^2 R_{e,\text{load}}$ . Solving the equations numerically using IHT yields

$$T_1 = 371 \text{ K}, T_2 = 354 \text{ K}, I = 0.22 \text{ A}, q_2 = 21.5 \text{ W}, P_N = 0.15 \text{ W}$$

These are the values for a single module. For an entire row:

$$\begin{aligned} q_{1,\text{tot}} &= 20q_1 = 432 \text{ W} \\ q_{2,\text{tot}} &= 20q_2 = 429 \text{ W} \\ P_{\text{tot}} &= 3 \text{ W} \end{aligned}$$

Thus, each row of modules generates 3.0 W of electricity and supplies 429 W to heat water. <

**COMMENTS:** (1) This technology provides combined hot water and electricity generation and could potentially displace photovoltaics. If hot water is stored in a thermal energy storage unit, it can be used to generate electricity 24 hours per day, exploiting nighttime radiation loss to the cold sky. (2) The heat entering the water will cause the water temperature to increase along a row of modules. This would have to be accounted for in a more accurate analysis. (3) The electrical conversion efficiency is  $P_{\text{tot}}/Mq_1 = 0.0069$ . This efficiency can be improved significantly with careful thermal design. For example, doubling the tube spacing to  $L_{\text{sep}} = 1 \text{ m}$  more than triples the electric power generated to  $P_{\text{tot}} = 10.4 \text{ W}$ . Can you explain why?

### PROBLEM 3.173

**KNOWN:** Size and temperatures of parallel aluminum plates. Spacing between the plates. Air between the plates.

**FIND:** The conduction heat transfer through the air.

**SCHEMATIC:**

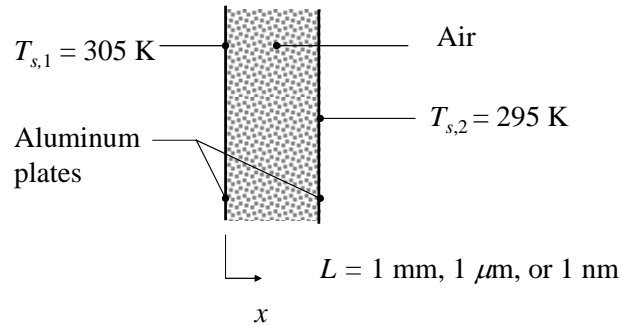

**ASSUMPTIONS:** (1) Ideal gas behavior.

**PROPERTIES:** Table A.4 ( $T = 300 \text{ K}$ ): Air;  $c_p = 1007 \text{ J/kg}\cdot\text{K}$ ,  $k = 0.0263 \text{ W/m}\cdot\text{K}$ . Figure 2.8: Air;  $\mathcal{M} = 28.97 \text{ kg/kmol}$ ,  $d = 0.372 \times 10^{-9} \text{ m}$ .

**ANALYSIS:** For air, the ideal gas constant, specific heat at constant volume, and ratio of specific heats are:

$$R = \frac{\mathcal{R}}{\mathcal{M}} = \frac{8.315 \text{ kJ/kmol}\cdot\text{K}}{28.97 \text{ kg/kmol}} = 0.287 \frac{\text{kJ}}{\text{kg}\cdot\text{K}};$$

$$c_v = c_p - R = 1.007 \frac{\text{kJ}}{\text{kg}\cdot\text{K}} - 0.287 \frac{\text{kJ}}{\text{kg}\cdot\text{K}} = 0.720 \frac{\text{kJ}}{\text{kg}\cdot\text{K}}; \quad \gamma = \frac{c_p}{c_v} = \frac{1.007}{0.720} = 1.399$$

From Equation 2.11 the mean free path of air is

$$\lambda_{\text{mfp}} = \frac{k_B T}{\sqrt{2} \pi d^2 p} = \frac{1.381 \times 10^{-23} \text{ J/K} \times 300 \text{ K}}{\sqrt{2} \pi (0.372 \times 10^{-9} \text{ m})^2 (1.0133 \times 10^5 \text{ N/m}^2)} = 66.5 \times 10^{-9} \text{ m} = 66.5 \text{ nm}$$

For  $L = 1 \text{ mm}$ ,

$$R_{t,m-m} = \frac{L}{kA} = \frac{1 \times 10^{-3} \text{ m}}{0.0263 \text{ W/m}\cdot\text{K} \times 10 \times 10^{-3} \text{ m} \times 10 \times 10^{-3} \text{ m}} = 380.2 \text{ K/W}$$

$$R_{t,m-s} = \frac{\lambda_{\text{mfp}}}{kA} \left[ \frac{2 - \alpha_t}{\alpha_t} \right] \left[ \frac{9\gamma - 5}{\gamma + 1} \right] = \frac{66.5 \times 10^{-9} \text{ m}}{0.0263 \text{ W/m}\cdot\text{K} \times 100 \times 10^{-6} \text{ m}^2} \left[ \frac{2 - 0.92}{0.92} \right] \left[ \frac{9 \times 1.399 - 5}{1.399 + 1} \right]$$

$$= 0.09392 \text{ K/W}$$

Hence, the conduction heat rate is

Continued...

**PROBLEM 3.173 (Cont.)**

$$q = \frac{T_{s,1} - T_{s,2}}{(R_{t,m-m} + R_{t,m-s})} = \frac{305\text{K} - 295\text{K}}{(380.2 \text{ K/W} + 0.09392 \text{ K/W})} = 0.0263 \text{ W} \quad <$$

For  $L = 1 \mu\text{m}$ ,

$$R_{t,m-m} = \frac{L}{kA} = \frac{1 \times 10^{-6} \text{ m}}{0.0263 \text{ W/m} \cdot \text{K} \times 10 \times 10^{-3} \text{ m} \times 10 \times 10^{-3} \text{ m}} = 0.3802 \text{ K/W}$$

$$R_{t,m-s} = 0.09392 \text{ K/W}$$

Hence, the conduction heat rate is

$$q = \frac{T_{s,1} - T_{s,2}}{(R_{t,m-m} + R_{t,m-s})} = \frac{305\text{K} - 295\text{K}}{(0.3802 \text{ K/W} + 0.09392 \text{ K/W})} = 21.09 \text{ W} \quad <$$

For  $L = 10 \text{ nm}$ ,

$$R_{t,m-m} = \frac{L}{kA} = \frac{10 \times 10^{-9} \text{ m}}{0.0263 \text{ W/m} \cdot \text{K} \times 10 \times 10^{-3} \text{ m} \times 10 \times 10^{-3} \text{ m}} = 0.0038 \text{ K/W}$$

$$R_{t,m-s} = 0.09392 \text{ K/W}$$

Hence, the conduction heat rate is

$$q = \frac{T_{s,1} - T_{s,2}}{(R_{t,m-m} + R_{t,m-s})} = \frac{305\text{K} - 295\text{K}}{(0.0038 \text{ K/W} + 0.09392 \text{ K/W})} = 102.3 \text{ W} \quad <$$

**COMMENT:** If the molecule-surface collision resistance were to be neglected, the heat rates would be  $q = 0.0263 \text{ W}$ ,  $26.3 \text{ W}$ , and  $2632 \text{ W}$  for the  $L = 1 \text{ mm}$ ,  $1 \text{ } \mu\text{m}$  and  $10 \text{ nm}$  plate spacings, respectively. Hence, molecule-surface collisions are negligible for large plate spacings, and dominant at small plate spacings.

### PROBLEM 3.174

**KNOWN:** Air or helium between steel and aluminum parallel plates, respectively. Gas temperature and pressure. Thermal accommodation coefficient values.

**FIND:** The separation distance,  $L$ , above which  $R_{t,m-s}/R_{t,m-m}$  is less than 0.01 for (a) air and (b) helium.

**SCHEMATIC:**

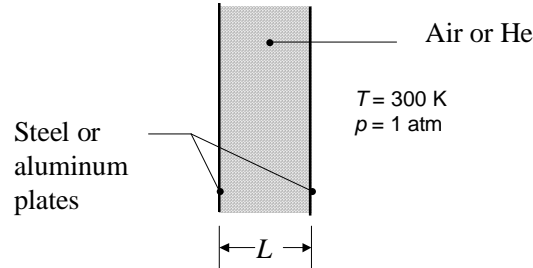

**ASSUMPTIONS:** (1) Ideal gas behavior, (2) One-dimensional conduction.

**PROPERTIES:** Table A.4 ( $T = 300$  K): Air;  $c_p = 1007$  J/kg·K,  $k = 0.0263$  W/m·K. He;  $c_p = 5193$  J/kg·K,  $k = 0.170$  W/m·K. Figure 2.8: Air;  $\mathcal{M} = 28.97$  kg/kmol,  $d = 0.372 \times 10^{-9}$  m. He;  $\mathcal{M} = 4.003$  kg/kmol,  $d = 0.219 \times 10^{-9}$  m.

**ANALYSIS:**

(a) For air, the ideal gas constant, specific heat at constant volume, and ratio of specific heats are:

$$R = \frac{\mathcal{R}}{\mathcal{M}} = \frac{8.315 \text{ kJ/kmol} \cdot \text{K}}{28.97 \text{ kg/kmol}} = 0.287 \frac{\text{kJ}}{\text{kg} \cdot \text{K}};$$

$$c_v = c_p - R = 1.007 \frac{\text{kJ}}{\text{kg} \cdot \text{K}} - 0.287 \frac{\text{kJ}}{\text{kg} \cdot \text{K}} = 0.720 \frac{\text{kJ}}{\text{kg} \cdot \text{K}}; \quad \gamma = \frac{c_p}{c_v} = \frac{1.007}{0.720} = 1.399$$

From Equation 2.11 the mean free path of air is

$$\lambda_{\text{mfp}} = \frac{k_B T}{\sqrt{2} \pi d^2 p} = \frac{1.381 \times 10^{-23} \text{ J/K} \times 300 \text{ K}}{\sqrt{2} \pi (0.372 \times 10^{-9} \text{ m})^2 (1.0133 \times 10^5 \text{ N/m}^2)} = 66.5 \times 10^{-9} \text{ m} = 66.5 \text{ nm}$$

From Section 3.9.1, the plate separation,  $L$ , is

$$L = \lambda_{\text{mfp}} \frac{R_{t,m-m}}{R_{t,m-s}} \left[ \frac{2 - \alpha_t}{\alpha_t} \right] \left[ \frac{9\gamma - 5}{\gamma + 1} \right]$$

$$= 66.5 \times 10^{-9} \text{ m} \times 100 \times \left[ \frac{2 - 0.92}{0.92} \right] \left[ \frac{9 \times 1.399 - 5}{1.399 + 1} \right] = 2.47 \times 10^{-5} \text{ m} = 24.7 \text{ } \mu\text{m}$$

<

Continued...

### PROBLEM 3.174 (Cont.)

(b) For He, the ideal gas constant, specific heat at constant volume, and ratio of specific heats are:

$$R = \frac{\mathcal{R}}{\mathcal{M}} = \frac{8.315 \text{ kJ/kmol} \cdot \text{K}}{4.003 \text{ kg/kmol}} = 2.077 \frac{\text{kJ}}{\text{kg} \cdot \text{K}};$$
$$c_v = c_p - R = 5.193 \frac{\text{kJ}}{\text{kg} \cdot \text{K}} - 2.077 \frac{\text{kJ}}{\text{kg} \cdot \text{K}} = 3.116 \frac{\text{kJ}}{\text{kg} \cdot \text{K}}; \quad \gamma = \frac{c_p}{c_v} = \frac{5.193}{3.116} = 1.667$$

The mean free path is

$$\lambda_{\text{mfp}} = \frac{k_B T}{\sqrt{2} \pi d^2 p} = \frac{1.381 \times 10^{-23} \text{ J/K} \times 300 \text{ K}}{\sqrt{2} \pi (0.219 \times 10^{-9} \text{ m})^2 (1.0133 \times 10^5 \text{ N/m}^2)} = 1.919 \times 10^{-7} \text{ m} = 192 \text{ nm}$$

The plate separation,  $L$ , is

$$L = \lambda_{\text{mfp}} \frac{R_{t,m-m}}{R_{t,m-s}} \left[ \frac{2 - \alpha_t}{\alpha_t} \right] \left[ \frac{9\gamma - 5}{\gamma + 1} \right]$$
$$= 1.919 \times 10^{-7} \text{ m} \times 100 \times \left[ \frac{2 - 0.02}{0.02} \right] \left[ \frac{9 \times 1.667 - 5}{1.667 + 1} \right] = 0.0071 \text{ m} = 7.1 \text{ mm}$$

<

**COMMENTS:** The critical plate separation associated with helium is  $7.1 \times 10^{-3} \text{ m} / 24.7 \times 10^{-6} \text{ m} = 290$  times greater than that for air. The thermal resistance associated with molecule-surface interactions can become significant for gases of small molecular diameter and for gas-surface material combinations that have a small thermal accommodation coefficient, even at relatively large plate separation distances (7.1 mm).



### PROBLEM 3.175

**KNOWN:** Thickness of parallel aluminum plates and air layers. Wall surface temperatures.

**FIND:** The conduction heat flux through (a) aluminum wall, (b) air layer, (c) air layer contained between two aluminum sheets and (d) composite wall consisting of 8 aluminum sheets and 7 air layers.

**SCHEMATIC:**

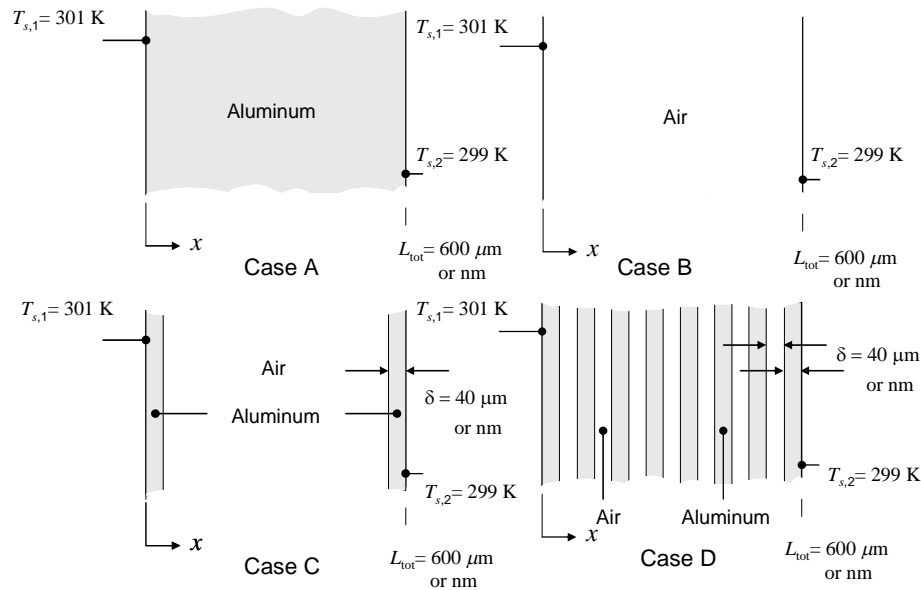

**ASSUMPTIONS:** (1) Ideal gas behavior. (2) Nanoscale effects within the solid are not important.

**PROPERTIES:** Table A.4 ( $T = 300 \text{ K}$ ): Air;  $c_p = 1007 \text{ J/kg}\cdot\text{K}$ ,  $k_{\text{Air}} = 0.0263 \text{ W/m}\cdot\text{K}$ . Figure 2.8: Air;  $\mathcal{M} = 28.97 \text{ kg/kmol}$ ,  $d = 0.372 \times 10^{-9} \text{ m}$ . Table A.1 ( $T = 300 \text{ K}$ ): Pure Aluminum,  $k_{\text{Al}} = 237 \text{ W/m}\cdot\text{K}$ .

**ANALYSIS:**

(a) Case A: Aluminum Wall

For  $L_{\text{tot}} = 600 \mu\text{m}$ , the heat flux is

$$q_x'' = \frac{k_{\text{Al}}(T_{s,1} - T_{s,2})}{L_{\text{tot}}} = \frac{237 \text{ W/m}\cdot\text{K}(301 \text{ K} - 299 \text{ K})}{600 \times 10^{-6} \text{ m}} = 7.9 \times 10^5 \text{ W/m}^2 <$$

Similarly, for  $L_{\text{tot}} = 600 \text{ nm}$ , the heat flux is  $q_x'' = 7.9 \times 10^8 \text{ W/m}^2 <$

Continued...

### PROBLEM 3.175 (Cont.)

(b) Case B: Air Layer

For  $L_{\text{tot}} = 600 \mu\text{m}$ , the heat flux is

$$q_x'' = \frac{k_{\text{Air}}(T_{s,1} - T_{s,2})}{L_{\text{tot}}} = \frac{0.0263 \text{ W/m} \cdot \text{K}(301 \text{ K} - 299 \text{ K})}{600 \times 10^{-6} \text{ m}} = 87.7 \text{ W/m}^2 \quad <$$

Similarly, for  $L_{\text{tot}} = 600 \text{ nm}$ , the heat flux is  $q_x'' = 87.7 \times 10^3 \text{ W/m}^2 \quad <$

(c) Case C: Air Layer between two Aluminum Sheets

This case involves a resistance due to molecule-molecule interactions, as well as molecule-surface collisions. For air, the ideal gas constant, specific heat at constant volume, and ratio of specific heats are:

$$R = \frac{\mathcal{R}}{\mathcal{M}} = \frac{8.315 \text{ kJ/kmol} \cdot \text{K}}{28.97 \text{ kg/kmol}} = 0.287 \frac{\text{kJ}}{\text{kg} \cdot \text{K}};$$

$$c_v = c_p - R = 1.007 \frac{\text{kJ}}{\text{kg} \cdot \text{K}} - 0.287 \frac{\text{kJ}}{\text{kg} \cdot \text{K}} = 0.720 \frac{\text{kJ}}{\text{kg} \cdot \text{K}}; \quad \gamma = \frac{c_p}{c_v} = \frac{1.007}{0.720} = 1.399$$

From Equation 2.11 the mean free path of air is

$$\lambda_{\text{mfp}} = \frac{k_B T}{\sqrt{2} \pi d^2 p} = \frac{1.381 \times 10^{-23} \text{ J/K} \times 300 \text{ K}}{\sqrt{2} \pi (0.372 \times 10^{-9} \text{ m})^2 (1.0133 \times 10^5 \text{ N/m}^2)} = 66.5 \times 10^{-9} \text{ m} = 66.5 \text{ nm}$$

For  $L_{\text{tot}} = 600 \mu\text{m}$ , the air layer is  $L = L_{\text{tot}} - 2\delta = 600 \mu\text{m} - 2 \times 40 \mu\text{m} = 520 \mu\text{m}$  thick.

$$R_{t,m-m}'' = \frac{L}{k_{\text{Air}}} = \frac{520 \times 10^{-6} \text{ m}}{0.0263 \text{ W/m} \cdot \text{K}} = 0.0198 \text{ K} \cdot \text{m}^2/\text{W}$$

$$R_{t,m-s}'' = \frac{\lambda_{\text{mfp}}}{k_{\text{Air}}} \left[ \frac{2 - \alpha_t}{\alpha_t} \right] \left[ \frac{9\gamma - 5}{\gamma + 1} \right] = \frac{66.5 \times 10^{-9} \text{ m}}{0.0263 \text{ W/m} \cdot \text{K}} \left[ \frac{2 - 0.92}{0.92} \right] \left[ \frac{9 \times 1.399 - 5}{1.399 + 1} \right]$$

$$= 9.39 \times 10^{-6} \text{ K} \cdot \text{m}^2/\text{W}$$

In addition, the aluminum sheets pose a cumulative thermal resistance of

$$R_{t,\text{cond}}'' = \frac{2\delta}{k_{\text{Al}}} = \frac{2 \times 40 \times 10^{-6} \text{ m}}{237 \text{ W/m} \cdot \text{K}} = 3.38 \times 10^{-7} \text{ K} \cdot \text{m}^2/\text{W}$$

Hence, the conduction heat flux is

Continued...

**PROBLEM 3.175 (Cont.)**

$$\begin{aligned} q_x'' &= \frac{T_{s,1} - T_{s,2}}{(R_{t,m-m}'' + R_{t,m-s}'' + R_{t,cond}'')} \\ &= \frac{301 \text{ K} - 299 \text{ K}}{(0.0198 \text{ K} \cdot \text{m}^2/\text{W} + 9.39 \times 10^{-6} \text{ K} \cdot \text{m}^2/\text{W} + 3.38 \times 10^{-7} \text{ K} \cdot \text{m}^2/\text{W})} \\ &= 101 \text{ W/m}^2 \end{aligned} \quad <$$

For  $L_{tot} = 600 \text{ nm}$ , the air layer is  $L = L_{tot} - 2\delta = 600 \text{ nm} - 2 \times 40 \text{ nm} = 520 \text{ nm}$  thick.

$$R_{t,m-m}'' = \frac{L}{k_{Air}} = \frac{520 \times 10^{-9} \text{ m}}{0.0263 \text{ W/m} \cdot \text{K}} = 19.8 \times 10^{-6} \text{ K} \cdot \text{m}^2/\text{W}$$

The aluminum sheets pose a cumulative thermal resistance of

$$R_{t,cond}'' = \frac{2\delta}{k_{Al}} = \frac{2 \times 40 \times 10^{-9} \text{ m}}{237 \text{ W/m} \cdot \text{K}} = 3.38 \times 10^{-10} \text{ K} \cdot \text{m}^2/\text{W}$$

Hence, the conduction heat flux is

$$\begin{aligned} q_x'' &= \frac{T_{s,1} - T_{s,2}}{(R_{t,m-m}'' + R_{t,m-s}'' + R_{t,cond}'')} \\ &= \frac{301 \text{ K} - 299 \text{ K}}{(19.8 \times 10^{-6} \text{ K} \cdot \text{m}^2/\text{W} + 9.39 \times 10^{-6} \text{ K} \cdot \text{m}^2/\text{W} + 3.38 \times 10^{-10} \text{ K} \cdot \text{m}^2/\text{W})} \\ &= 68.6 \times 10^3 \text{ W/m}^2 \end{aligned} \quad <$$

(d) Case D: Seven Air Layers between Eight Aluminum Sheets

This case involves multiple resistances due to molecule-molecule interactions, as well as molecule-surface collisions at multiple surfaces.

For  $L_{tot} = 600 \text{ } \mu\text{m}$ , each air layer is  $L = L_{tot} \times (1/15) = 600 \text{ } \mu\text{m} \times (1/15) = 40 \text{ } \mu\text{m}$  thick. Hence, for each air layer

$$R_{t,m-m}'' = \frac{L}{k_{Air}} = \frac{40 \times 10^{-6} \text{ m}}{0.0263 \text{ W/m} \cdot \text{K}} = 1.52 \times 10^{-3} \text{ K} \cdot \text{m}^2/\text{W}$$

In addition, the aluminum sheets pose a cumulative thermal resistance of

$$R_{t,cond}'' = \frac{8\delta}{k_{Al}} = \frac{8 \times 40 \times 10^{-6} \text{ m}}{237 \text{ W/m} \cdot \text{K}} = 1.35 \times 10^{-6} \text{ K} \cdot \text{m}^2/\text{W}$$

Continued...

**Problem 3.175 (Cont.)**

Hence, the conduction heat flux is

$$\begin{aligned}
 q_x'' &= \frac{T_{s,1} - T_{s,2}}{(7R_{t,m-m}'' + 7R_{t,m-s}'' + R_{t,cond}'')} \\
 &= \frac{301 \text{ K} - 299 \text{ K}}{(7 \times 1.52 \times 10^{-3} \text{ K} \cdot \text{m}^2/\text{W} + 7 \times 9.39 \times 10^{-6} \text{ K} \cdot \text{m}^2/\text{W} + 1.35 \times 10^{-6} \text{ K} \cdot \text{m}^2/\text{W})} < \\
 &= 186.7 \text{ W/m}^2
 \end{aligned}$$

For  $L_{tot} = 600 \text{ nm}$ , each air layer is  $L = L_{tot} \times (1/15) = 600 \text{ nm} \times (1/15) = 40 \text{ nm}$  thick. Hence, for each air layer

$$R_{t,m-m}'' = \frac{L}{k_{Air}} = \frac{40 \times 10^{-9} \text{ m}}{0.0263 \text{ W/m} \cdot \text{K}} = 1.52 \times 10^{-6} \text{ K} \cdot \text{m}^2/\text{W}$$

In addition, the aluminum sheets pose a cumulative thermal resistance of

$$R_{t,cond}'' = \frac{8\delta}{k_{Al}} = \frac{8 \times 40 \times 10^{-9} \text{ m}}{237 \text{ W/m} \cdot \text{K}} = 1.35 \times 10^{-9} \text{ K} \cdot \text{m}^2/\text{W}$$

Hence, the conduction heat flux is

$$\begin{aligned}
 q_x'' &= \frac{T_{s,1} - T_{s,2}}{(7R_{t,m-m}'' + 7R_{t,m-s}'' + R_{t,cond}'')} \\
 &= \frac{301 \text{ K} - 299 \text{ K}}{(7 \times 1.52 \times 10^{-6} \text{ K} \cdot \text{m}^2/\text{W} + 7 \times 9.39 \times 10^{-6} \text{ K} \cdot \text{m}^2/\text{W} + 1.35 \times 10^{-9} \text{ K} \cdot \text{m}^2/\text{W})} < \\
 &= 26.2 \times 10^3 \text{ W/m}^2
 \end{aligned}$$

The predicted heat fluxes are summarized below.

Case	$L_{tot} = 600 \mu\text{m}$	$L_{tot} = 600 \text{ nm}$
A	$q_x'' = 7.9 \times 10^5 \text{ W/m}^2 \cdot \text{K}$	$q_x'' = 7.9 \times 10^8 \text{ W/m}^2 \cdot \text{K}$
B	$q_x'' = 87.7 \text{ W/m}^2 \cdot \text{K}$	$q_x'' = 87.7 \times 10^3 \text{ W/m}^2 \cdot \text{K}$
C	$q_x'' = 101 \text{ W/m}^2 \cdot \text{K}$	$q_x'' = 68.6 \times 10^3 \text{ W/m}^2 \cdot \text{K}$
D	$q_x'' = 186.7 \text{ W/m}^2 \cdot \text{K}$	$q_x'' = 26.2 \times 10^3 \text{ W/m}^2 \cdot \text{K}$

Continued...

### PROBLEM 3.175 (Cont.)

**COMMENTS:** (1) For the  $L_{\text{tot}} = 600 \mu\text{m}$  cases, it is readily evident that the highest heat flux corresponds to Case A in which conduction occurs exclusively through the high thermal conductivity aluminum. The lowest heat flux is associated with conduction through the pure air layer (Case B). For the case involving two aluminum sheets (Case C) the heat flux is increased relative to Case B primarily in response to replacing some low thermal conductivity air with high thermal conductivity metal. However, as more aluminum sheets are added, the thermal resistance across the entire layer is reduced, leading to increases in the heat flux for Case D. In each case, the resistance posed by molecule-surface interactions is not significant. Specifically, heat transfer rates for Cases C and D, calculated without accounting for the molecule-surface collisions, are  $101 \text{ W/m}^2$  and  $187.8 \text{ W/m}^2$ , respectively.

(2) For the  $L_{\text{tot}} = 600 \text{ nm}$  cases, we again observe that the largest heat flux is associated with conduction exclusively within the aluminum (Case A). *However, consideration of the other three cases reveals nanoscale behavior that would be unexpected from the macroscale point-of-view.* Specifically, Case B involving conduction through pure air is no longer characterized by the lowest heat flux. Rather, we observe that as more sheets of high thermal conductivity metal are added to the composite layer, the heat flux is *reduced*, with the minimum heat flux associated with the most aluminum sheets, Case D. The reduction in the conduction resistance due to the replacement of low thermal conductivity air with high thermal conductivity metal is more than offset with the increase in the total thermal resistance that is associated with molecule-surface interactions at the interfaces between the aluminum sheets and the air. The molecule-surface interactions can have a profound effect on nanoscale heat transfer.

(3) Nanoscale effects could become important in the solid as the thickness of the solid approaches the mean free path. See Table 2.1.

### PROBLEM 3.176

**KNOWN:** Knudsen number, specific heat ratio and thermal accommodation coefficient for an ideal gas and solid surface.

**FIND:** Expression for the the ratio of the thermal resistance due to molecule-surface collisions to the thermal resistance associated with molecule-molecule collisions,  $R_{t,m-s}/R_{t,m-m}$ .

**ASSUMPTIONS:** (1) Ideal gas behavior.

**ANALYSIS:** The expressions for  $R_{t,m-m}$  and  $R_{t,m-s}$  are

$$R_{t,m-m} = \frac{L}{kA} \quad \text{and} \quad R_{t,m-s} = \frac{\lambda_{\text{mfp}}}{kA} \left[ \frac{2 - \alpha_t}{\alpha_t} \right] \left[ \frac{9\gamma - 5}{\gamma + 1} \right]$$

therefore,

$$\frac{R_{t,m-s}}{R_{t,m-m}} = \frac{\lambda_{\text{mfp}}}{L} \left[ \frac{2 - \alpha_t}{\alpha_t} \right] \left[ \frac{9\gamma - 5}{\gamma + 1} \right] = Kn \left[ \frac{2 - \alpha_t}{\alpha_t} \right] \left[ \frac{9\gamma - 5}{\gamma + 1} \right] \quad <$$

Associating the critical Knudsen number,  $Kn_{\text{crit}}$ , with  $R_{t,m-s}/R_{t,m-m} = 0.01$ , we may plot the value of the critical Knudsen number for  $\gamma = 1.4$  and  $1.67$  over the range  $0.01 \leq \alpha_t \leq 1$  as shown below.

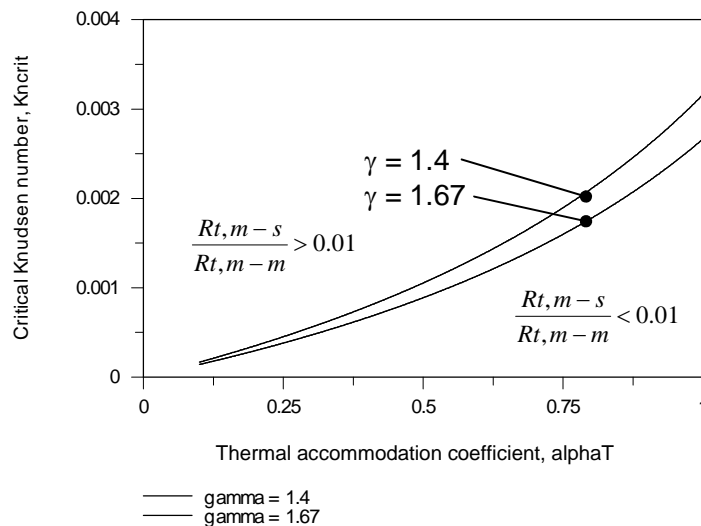

**COMMENTS:** (1) Relatively large Knudsen numbers are associated with more significant surface-molecule collisions. (2) The critical Knudsen number is relatively insensitive to the specific heat ratio,  $\gamma$ .

### PROBLEM 3.177

**KNOWN:** Thickness of alternating tungsten and aluminum oxide layers, interface thermal resistance, thermal conductivities of tungsten and aluminum oxide thin films.

**FIND:** (a) Effective thermal conductivity of the nanolaminate. Comparison with bulk thermal conductivities of aluminum oxide and tungsten, (b) Effective thermal conductivity of the nanolaminate using bulk values of the thermal conductivity of aluminum oxide and tungsten.

**SCHEMATIC:**

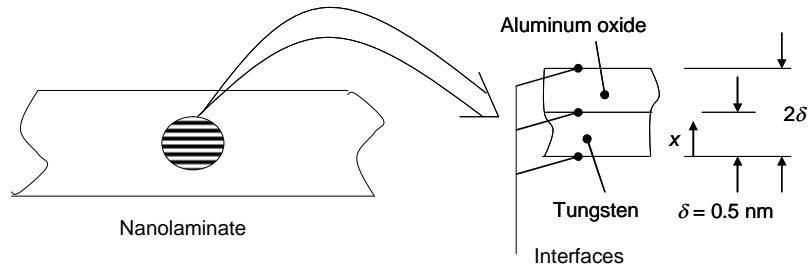

**ASSUMPTIONS:** (1) Steady-state, one-dimensional conditions, (2) Constant properties.

**PROPERTIES:** Table A.1, tungsten (300 K):  $k_T = 174 \text{ W/m}\cdot\text{K}$ . Table A.2, aluminum oxide (300 K):  $k_A = 36 \text{ W/m}\cdot\text{K}$ .

**ANALYSIS:** (a) Consider a unit cell consisting of one layer of aluminum oxide, one layer of tungsten, and two interfaces of unit cell thickness  $2\delta = 1.0 \text{ nm}$  as shown in the schematic. The sum of the thermal resistances is

$$\sum R_t'' = 2(R_{t,i}'') + \frac{\delta}{k_A} + \frac{\delta}{k_T} = 2 \times 3.85 \times 10^{-9} \frac{\text{m}^2 \cdot \text{K}}{\text{W}} + \frac{0.5 \times 10^{-9} \text{ m}}{1.65 \text{ W/m}\cdot\text{K}} + \frac{0.5 \times 10^{-9} \text{ m}}{6.10 \text{ W/m}\cdot\text{K}} = 8.08 \times 10^{-9} \frac{\text{m}^2 \cdot \text{K}}{\text{W}}$$

The effective thermal conductivity is

$$k_{\text{eff}} = \frac{L}{\sum R_t''} = \frac{2\delta}{\sum R_t''} = \frac{2 \times 0.5 \times 10^{-9} \text{ m}}{8.08 \times 10^{-9} \frac{\text{m}^2 \cdot \text{K}}{\text{W}}} = 0.123 \frac{\text{W}}{\text{m}\cdot\text{K}} <$$

The value of the effective thermal conductivity is  $0.123/174 \times 100 = 0.07\%$  that of bulk tungsten and  $0.123/36 \times 100 = 0.34\%$  that of bulk aluminum oxide.

(b) Repeating part (a) using  $k_T = 174 \text{ W/m}\cdot\text{K}$  and  $k_A = 36 \text{ W/m}\cdot\text{K}$  yields  $k_{\text{eff}} = 0.129 \frac{\text{W}}{\text{m}\cdot\text{K}} <$

**COMMENTS:** (1) The effective thermal conductivity is dominated by the interface resistances and is relatively insensitive to the thermal conductivity of the two materials. Although the interface resistance is very small compared to typical contact resistance values (see Table 3.2), by using extremely thin layer thicknesses, many such interfaces may be packed into the laminated structure, resulting in very small values of the effective or bulk thermal conductivity. The material service temperature would be limited to values less than approximately  $1000^\circ\text{C}$ , due to the tendency of the material to lose thermal stability at high temperatures and, in turn, lose its nanolaminated structure. (2) See Costescu, Cahill, Fabreguette, Sechrist, and George, "Ultra-Low Thermal Conductivity in  $\text{W}/\text{Al}_2\text{O}_3$  Nanolaminates," *Science*, Vol. 303, pp. 989 – 990, 2004, for additional information.

### PROBLEM 3.178

**KNOWN:** Dimensions of and temperature difference applied across thin gold film.

**FIND:** (a) Energy conducted along the film, (b) Plot the thermal conductivity along and across the thin dimension of the film, for film thicknesses  $30 \leq L \leq 140$  nm.

**SCHEMATIC:**

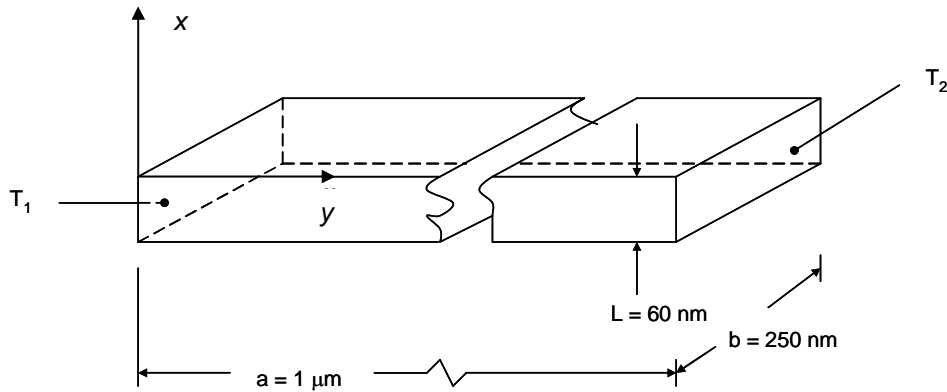

**ASSUMPTIONS:** (1) One-dimensional conduction in the x- and y-directions, (2) Steady-state conditions, (3) Constant properties, (4) Thermal conductivity not affected by nanoscale effects associated with 250 nm dimension.

**PROPERTIES:** Table A.1, gold (bulk, 300 K):  $k = 317$  W/m·K.

**ANALYSIS:**

a) From Fourier's law,

$$q_y = -kA \frac{dT}{dy} = k_y L b \left[ \frac{T_1 - T_2}{a} \right] \quad (1)$$

From Eq. 2.9b,

$$k_y = k \left[ 1 - \frac{2\lambda_{\text{mfp}}}{3\pi L} \right] \quad (2)$$

Combining Eqs. (1) and (2), and using the value of  $\lambda_{\text{mfp}} = 31$  nm from Table 2.1 yields

$$\begin{aligned} q_y &= k \left[ 1 - \frac{2\lambda_{\text{mfp}}}{3\pi L} \right] L b \left[ \frac{T_1 - T_2}{a} \right] \\ &= 317 \frac{\text{W}}{\text{m} \cdot \text{K}} \times \left[ 1 - \frac{2 \times 31 \times 10^{-9} \text{ m}}{3 \times \pi \times 60 \times 10^{-9} \text{ m}} \right] \times 60 \times 10^{-9} \text{ m} \times 250 \times 10^{-9} \text{ m} \times \frac{20^\circ\text{C}}{1 \times 10^{-6} \text{ m}} \\ &= 85 \times 10^{-6} \text{ W} = 85 \mu\text{W} \quad < \end{aligned}$$

(b) The spanwise thermal conductivity may be found from Eq. 2.9a,

$$k_x = k \left[ 1 - \frac{\lambda_{\text{mfp}}}{3L} \right] \quad (3)$$

Continued...



### PROBLEM 3.178 (Cont.)

The plot is shown below.

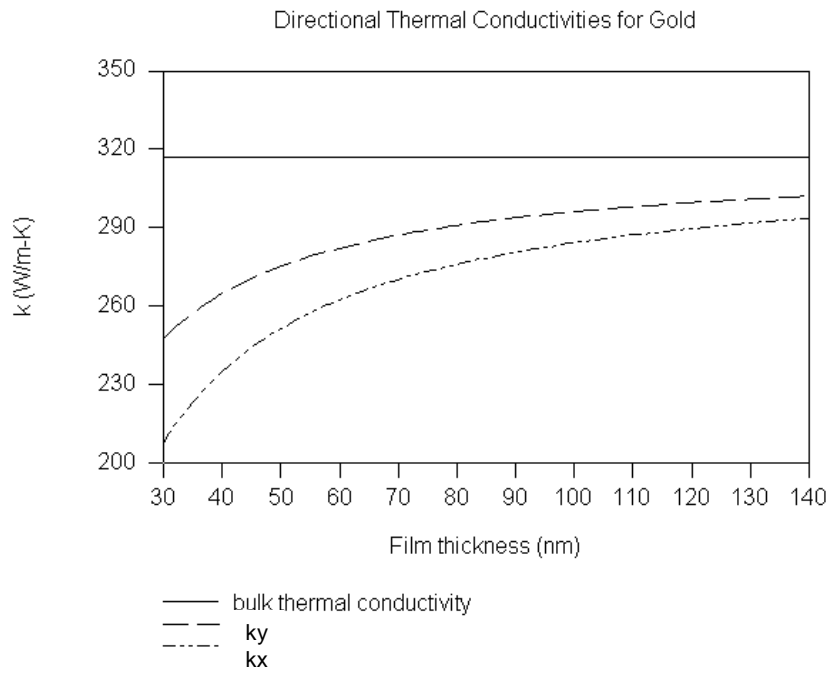

**COMMENT:** Nanoscale effects become less significant as the thickness of the film is increased.

### PROBLEM 4.1

**KNOWN:** Method of separation of variables for two-dimensional, steady-state conduction.

**FIND:** Show that negative or zero values of  $\lambda^2$ , the separation constant, result in solutions which cannot satisfy the boundary conditions.

**SCHEMATIC:**

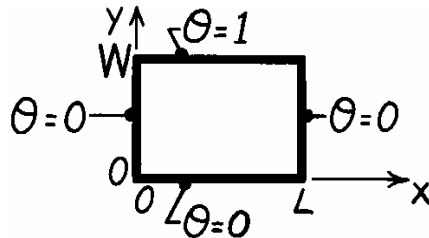

**ASSUMPTIONS:** (1) Two-dimensional, steady-state conduction, (2) Constant properties.

**ANALYSIS:** From Section 4.2, identification of the separation constant  $\lambda^2$  leads to the two ordinary differential equations, 4.6 and 4.7, having the forms

$$\frac{d^2X}{dx^2} + \lambda^2 X = 0 \qquad \frac{d^2Y}{dy^2} - \lambda^2 Y = 0 \qquad (1,2)$$

and the temperature distribution is  $\theta(x,y) = X(x) \cdot Y(y)$ . (3)

Consider now the situation when  $\lambda^2 = 0$ . From Eqs. (1), (2), and (3), find that

$$X = C_1 + C_2 x, \quad Y = C_3 + C_4 y \quad \text{and} \quad \theta(x,y) = (C_1 + C_2 x) (C_3 + C_4 y). \qquad (4)$$

Evaluate the constants -  $C_1, C_2, C_3$  and  $C_4$  - by substitution of the boundary conditions:

$$\begin{array}{lll} x = 0: & \theta(0,y) = (C_1 + C_2 \cdot 0)(C_3 + C_4 \cdot y) = 0 & C_1 = 0 \\ y = 0: & \theta(x,0) = (0 + C_2 \cdot x)(C_3 + C_4 \cdot 0) = 0 & C_3 = 0 \\ x = L: & \theta(L,0) = (0 + C_2 \cdot L)(0 + C_4 \cdot y) = 0 & C_2 = 0 \\ y = W: & \theta(x,W) = (0 + 0 \cdot x)(0 + C_4 \cdot W) = 1 & 0 \neq 1 \end{array}$$

The last boundary condition leads to an impossibility ( $0 \neq 1$ ). We therefore conclude that a  $\lambda^2$  value of zero will not result in a form of the temperature distribution which will satisfy the boundary conditions. Consider now the situation when  $\lambda^2 < 0$ . The solutions to Eqs. (1) and (2) will be

$$X = C_5 e^{-\lambda x} + C_6 e^{+\lambda x}, \qquad Y = C_7 \cos \lambda y + C_8 \sin \lambda y \qquad (5,6)$$

and  $\theta(x,y) = [C_5 e^{-\lambda x} + C_6 e^{+\lambda x}] [C_7 \cos \lambda y + C_8 \sin \lambda y]$ . (7)

Evaluate the constants for the boundary conditions.

$$\begin{array}{lll} y = 0: & \theta(x,0) = [C_5 e^{-\lambda x} + C_6 e^{+\lambda x}] [C_7 \cos 0 + C_8 \sin 0] = 0 & C_7 = 0 \\ x = 0: & \theta(0,y) = [C_5 e^0 + C_6 e^0] [0 + C_8 \sin \lambda y] = 0 & C_8 = 0 \end{array}$$

If  $C_8 = 0$ , a trivial solution results or  $C_5 = -C_6$ .

$$x = L: \quad \theta(L,y) = C_5 [e^{-\lambda L} - e^{+\lambda L}] C_8 \sin \lambda y = 0.$$

From the last boundary condition, we require  $C_5$  or  $C_8$  is zero; either case leads to a trivial solution with either no x or y dependence.

## PROBLEM 4.2

**KNOWN:** Two-dimensional rectangular plate subjected to prescribed uniform temperature boundary conditions.

**FIND:** Temperature at the mid-point using the exact solution considering the first five non-zero terms; assess error resulting from using only first three terms. Plot the temperature distributions  $T(x,0.5)$  and  $T(1,y)$ .

**SCHEMATIC:**

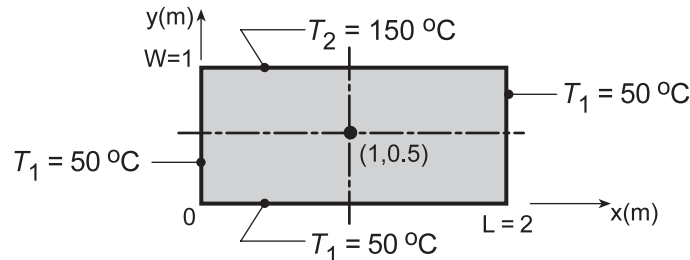

**ASSUMPTIONS:** (1) Two-dimensional, steady-state conduction, (2) Constant properties.

**ANALYSIS:** From Section 4.2, the temperature distribution is

$$\theta(x, y) \equiv \frac{T - T_1}{T_2 - T_1} = \frac{2}{\pi} \sum_{n=1}^{\infty} \frac{(-1)^{n+1} + 1}{n} \sin\left(\frac{n\pi x}{L}\right) \cdot \frac{\sinh(n\pi y/L)}{\sinh(n\pi W/L)}. \quad (1,4.19)$$

Considering now the point  $(x, y) = (1.0, 0.5)$  and recognizing  $x/L = 1/2$ ,  $y/L = 1/4$  and  $W/L = 1/2$ ,

$$\theta(1, 0.5) \equiv \frac{T - T_1}{T_2 - T_1} = \frac{2}{\pi} \sum_{n=1}^{\infty} \frac{(-1)^{n+1} + 1}{n} \sin\left(\frac{n\pi}{2}\right) \cdot \frac{\sinh(n\pi/4)}{\sinh(n\pi/2)}.$$

When  $n$  is even (2, 4, 6 ...), the corresponding term is zero; hence we need only consider  $n = 1, 3, 5, 7$  and 9 as the first five non-zero terms.

$$\begin{aligned} \theta(1, 0.5) &= \frac{2}{\pi} \left\{ 2 \sin\left(\frac{\pi}{2}\right) \frac{\sinh(\pi/4)}{\sinh(\pi/2)} + \frac{2}{3} \sin\left(\frac{3\pi}{2}\right) \frac{\sinh(3\pi/4)}{\sinh(3\pi/2)} + \right. \\ &\quad \left. \frac{2}{5} \sin\left(\frac{5\pi}{2}\right) \frac{\sinh(5\pi/4)}{\sinh(5\pi/2)} + \frac{2}{7} \sin\left(\frac{7\pi}{2}\right) \frac{\sinh(7\pi/4)}{\sinh(7\pi/2)} + \frac{2}{9} \sin\left(\frac{9\pi}{2}\right) \frac{\sinh(9\pi/4)}{\sinh(9\pi/2)} \right\} \\ \theta(1, 0.5) &= \frac{2}{\pi} [0.755 - 0.063 + 0.008 - 0.001 + 0.000] = 0.445 \end{aligned} \quad (2)$$

$$T(1, 0.5) = \theta(1, 0.5)(T_2 - T_1) + T_1 = 0.445(150 - 50) + 50 = 94.5^\circ \text{C}. \quad <$$

If only the first three terms of the series, Eq. (2), are considered, the result will be  $\theta(1, 0.5) = 0.46$ ; that is, there is less than a 0.2% effect.

Using Eq. (1), and writing out the first five terms of the series, expressions for  $\theta(x, 0.5)$  or  $T(x, 0.5)$  and  $\theta(1, y)$  or  $T(1, y)$  were keyboarded into the IHT workspace and evaluated for sweeps over the  $x$  or  $y$  variable. Note that for  $T(1, y)$ , that as  $y \rightarrow 1$ , the upper boundary,  $T(1, 1)$  is greater than  $150^\circ \text{C}$ . Upon examination of the magnitudes of terms, it becomes evident that more than 5 terms are required to provide an accurate solution.

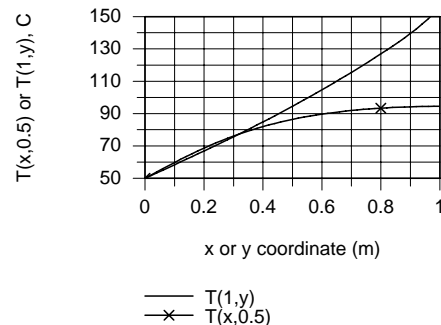

### PROBLEM 4.3

**KNOWN:** Temperature distribution in the two-dimensional rectangular plate of Problem 4.2.

**FIND:** Expression for the heat rate per unit thickness from the lower surface ( $0 \leq x \leq 2, 0$ ) and result based on first five non-zero terms of the infinite series.

**SCHEMATIC:**

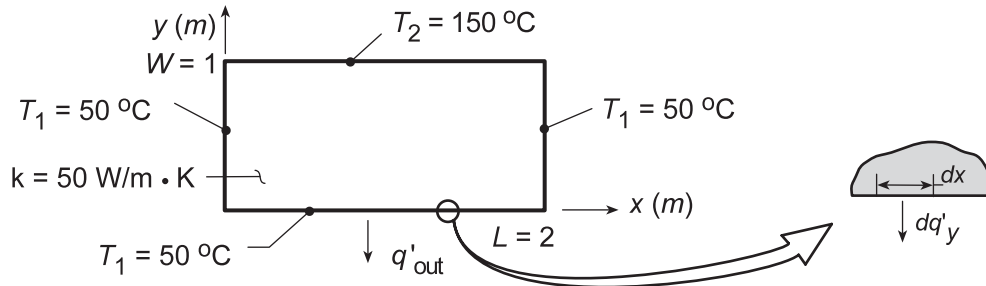

**ASSUMPTIONS:** (1) Two-dimensional, steady-state conduction, (2) Constant properties.

**ANALYSIS:** The heat rate per unit thickness from the plate along the lower surface is

$$q'_{\text{out}} = - \int_{x=0}^{x=2} dq'_y(x, 0) = - \int_{x=0}^{x=2} -k \left. \frac{\partial T}{\partial y} \right|_{y=0} dx = k(T_2 - T_1) \int_{x=0}^{x=2} \left. \frac{\partial \theta}{\partial y} \right|_{y=0} dx \quad (1)$$

where from the solution to Problem 4.2,

$$\theta \equiv \frac{T - T_1}{T_2 - T_1} = \frac{2}{\pi} \sum_{n=1}^{\infty} \frac{(-1)^{n+1} + 1}{n} \sin\left(\frac{n\pi x}{L}\right) \frac{\sinh(n\pi y/L)}{\sinh(n\pi W/L)}. \quad (2)$$

Evaluate the gradient of  $\theta$  from Eq. (2) and substitute into Eq. (1) to obtain

$$q'_{\text{out}} = k(T_2 - T_1) \int_{x=0}^{x=2} \frac{2}{\pi} \sum_{n=1}^{\infty} \frac{(-1)^{n+1} + 1}{n} \sin\left(\frac{n\pi x}{L}\right) \frac{(n\pi/L) \cosh(n\pi y/L)}{\sinh(n\pi W/L)} \Big|_{y=0} dx$$

$$q'_{\text{out}} = k(T_2 - T_1) \frac{2}{\pi} \sum_{n=1}^{\infty} \frac{(-1)^{n+1} + 1}{n} \frac{1}{\sinh(n\pi W/L)} \left[ -\cos\left(\frac{n\pi x}{L}\right) \Big|_{x=0}^2 \right]$$

$$q'_{\text{out}} = k(T_2 - T_1) \frac{2}{\pi} \sum_{n=1}^{\infty} \frac{(-1)^{n+1} + 1}{n} \frac{1}{\sinh(n\pi/L)} [1 - \cos(n\pi)] \quad <$$

To evaluate the first five, non-zero terms, recognize that since  $\cos(n\pi) = 1$  for  $n = 2, 4, 6 \dots$ , only the  $n$ -odd terms will be non-zero. Hence,

Continued ...

**PROBLEM 4.3 (Cont.)**

$$q'_{\text{out}} = 50 \text{ W/m} \cdot \text{K} (150 - 50)^\circ \text{C} \frac{2}{\pi} \left\{ \frac{(-1)^2 + 1}{1} \cdot \frac{1}{\sinh(\pi/2)} (2) + \frac{(-1)^4 + 1}{3} \cdot \frac{1}{\sinh(3\pi/2)} (2) \right. \\ \left. + \frac{(-1)^6 + 1}{5} \cdot \frac{1}{\sinh(5\pi/2)} (2) + \frac{(-1)^8 + 1}{7} \cdot \frac{1}{\sinh(7\pi/2)} (2) + \frac{(-1)^{10} + 1}{9} \cdot \frac{1}{\sinh(9\pi/2)} (2) \right\}$$

$$q'_{\text{out}} = 3.183 \text{ kW/m} [1.738 + 0.024 + 0.00062 + (\dots)] = 5.611 \text{ kW/m} \quad <$$

**COMMENTS:** If the foregoing procedure were used to evaluate the heat rate into the upper surface,

$q'_{\text{in}} = - \int_{x=0}^{x=2} dq'_y(x, W)$ , it would follow that

$$q'_{\text{in}} = k(T_2 - T_1) \frac{2}{\pi} \sum_{n=1}^{\infty} \frac{(-1)^{n+1} + 1}{n} \coth(n\pi/2) [1 - \cos(n\pi)]$$

However, with  $\coth(n\pi/2) \geq 1$ , irrespective of the value of  $n$ , and with  $\sum_{n=1}^{\infty} [(-1)^{n+1} + 1] / n$  being a divergent series, the complete series does not converge and  $q'_{\text{in}} \rightarrow \infty$ . This physically untenable condition results from the temperature discontinuities imposed at the upper left and right corners.

### PROBLEM 4.4

**KNOWN:** Rectangular plate subjected to prescribed boundary conditions.

**FIND:** Steady-state temperature distribution.

**SCHEMATIC:**

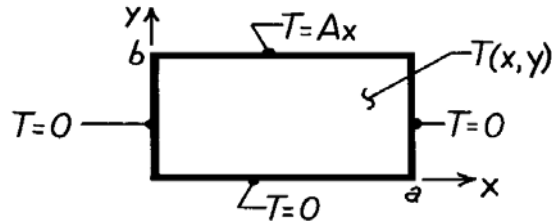

**ASSUMPTIONS:** (1) Steady-state, 2-D conduction, (2) Constant properties.

**ANALYSIS:** The solution follows the method of Section 4.2. The product solution is

$$T(x,y) = X(x) \cdot Y(y) = (C_1 \cos \lambda x + C_2 \sin \lambda x) (C_3 e^{-\lambda y} + C_4 e^{+\lambda y})$$

and the boundary conditions are:  $T(0,y) = 0$ ,  $T(a,y) = 0$ ,  $T(x,0) = 0$ ,  $T(x,b) = Ax$ . Applying BC#1,  $T(0,y) = 0$ , find  $C_1 = 0$ . Applying BC#2,  $T(a,y) = 0$ , find that  $\lambda = n\pi/a$  with  $n = 1, 2, \dots$ . Applying BC#3,  $T(x,0) = 0$ , find that  $C_3 = -C_4$ . Hence, the product solution is

$$T(x,y) = X(x) \cdot Y(y) = C_2 C_4 \sin \left[ \frac{n\pi x}{a} \right] \left( e^{+\lambda y} - e^{-\lambda y} \right).$$

Combining constants and using superposition, find

$$T(x,y) = \sum_{n=1}^{\infty} C_n \sin \left[ \frac{n\pi x}{a} \right] \sinh \left[ \frac{n\pi y}{a} \right].$$

To evaluate  $C_n$  and satisfy BC#4, use orthogonal functions with Equation 4.16 to find

$$C_n = \int_0^a Ax \cdot \sin \left[ \frac{n\pi x}{a} \right] \cdot dx / \sinh \left[ \frac{n\pi b}{a} \right] \int_0^a \sin^2 \left[ \frac{n\pi x}{a} \right] dx,$$

noting that  $y = b$ . The numerator, denominator and  $C_n$ , respectively, are:

$$A \int_0^a x \cdot \sin \frac{n\pi x}{a} \cdot dx = A \left[ \left[ \frac{a}{n\pi} \right]^2 \sin \left[ \frac{n\pi x}{a} \right] - \frac{ax}{n\pi} \cos \left[ \frac{n\pi x}{a} \right] \right]_0^a = \frac{Aa^2}{n\pi} [-\cos(n\pi)] = \frac{Aa^2}{n\pi} (-1)^{n+1},$$

$$\sinh \left[ \frac{n\pi b}{a} \right] \int_0^a \sin^2 \frac{n\pi x}{a} \cdot dx = \sinh \left[ \frac{n\pi b}{a} \right] \left[ \frac{1}{2} x - \frac{a}{4n\pi} \sin \left[ \frac{2n\pi x}{a} \right] \right]_0^a = \frac{a}{2} \cdot \sinh \left[ \frac{n\pi b}{a} \right],$$

$$C_n = \frac{Aa^2}{n\pi} (-1)^{n+1} / \frac{a}{2} \sinh \left[ \frac{n\pi b}{a} \right] = 2Aa (-1)^{n+1} / n\pi \sinh \left[ \frac{n\pi b}{a} \right].$$

Hence, the temperature distribution is

$$T(x,y) = \frac{2Aa}{\pi} \sum_{n=1}^{\infty} \frac{(-1)^{n+1}}{n} \cdot \sin \left[ \frac{n\pi x}{a} \right] \frac{\sinh \left[ \frac{n\pi y}{a} \right]}{\sinh \left[ \frac{n\pi b}{a} \right]}.$$

<

### PROBLEM 4.5

**KNOWN:** Boundary conditions on four sides of a rectangular plate.

**FIND:** Temperature distribution.

**SCHEMATIC:**

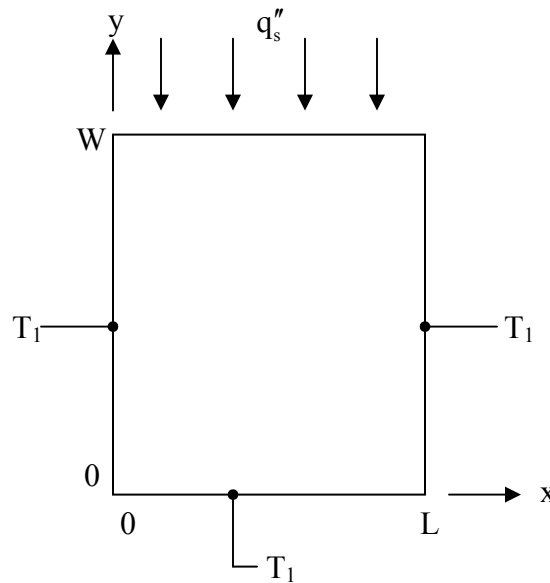

**ASSUMPTIONS:** (1) Two-dimensional, steady-state conduction, (2) Constant properties.

**ANALYSIS:** This problem differs from the one solved in Section 4.2 only in the boundary condition at the top surface. Defining  $\theta = T - T_\infty$ , the differential equation and boundary conditions are

$$\frac{\partial^2 \theta}{\partial x^2} + \frac{\partial^2 \theta}{\partial y^2} = 0$$

$$\theta(0, y) = 0 \quad \theta(L, y) = 0 \quad \theta(x, 0) = 0 \quad k \left. \frac{\partial \theta}{\partial y} \right|_{y=W} = q_s'' \quad (1a,b,c,d)$$

The solution is identical to that in Section 4.2 through Equation (4.11),

$$\theta = \sum_{n=1}^{\infty} C_n \sin \frac{n\pi x}{L} \sinh \frac{n\pi y}{L} \quad (2)$$

To determine  $C_n$ , we now apply the top surface boundary condition, Equation (1d). Differentiating Equation (2) yields

Continued...

### PROBLEM 4.5 (Cont.)

$$\left. \frac{\partial \theta}{\partial y} \right|_{y=W} = \sum_{n=1}^{\infty} C_n \frac{n\pi}{L} \sin \frac{n\pi x}{L} \cosh \frac{n\pi W}{L} \quad (3)$$

Substituting this into Equation (1d) results in

$$\frac{q_s''}{k} = \sum_{n=1}^{\infty} A_n \sin \frac{n\pi x}{L} \quad (4)$$

where  $A_n = C_n(n\pi/L)\cosh(n\pi W/L)$ . The principles expressed in Equations (4.13) through (4.16) still apply, but now with reference to Equation (4) and Equation (4.14), we should choose

$f(x) = q_s''/k$ ,  $g_n(x) = \sin \frac{n\pi x}{L}$ . Equation (4.16) then becomes

$$A_n = \frac{\frac{q_s''}{k} \int_0^L \sin \frac{n\pi x}{L} dx}{\int_0^L \sin^2 \frac{n\pi x}{L} dx} = \frac{q_s''}{k} \frac{2}{\pi} \frac{(-1)^{n+1} + 1}{n}$$

Thus

$$C_n = 2 \frac{q_s'' L}{k} \frac{(-1)^{n+1} + 1}{n^2 \pi^2 \cosh(n\pi W/L)} \quad (5)$$

The solution is given by Equation (2) with  $C_n$  defined by Equation (5).



## PROBLEM 4.6

**KNOWN:** Uniform media of prescribed geometry.

**FIND:** (a) Shape factor expressions from thermal resistance relations for the plane wall, cylindrical shell and spherical shell, (b) Shape factor expression for the isothermal sphere of diameter  $D$  buried in an infinite medium.

**ASSUMPTIONS:** (1) Steady-state conditions, (2) Uniform properties.

**ANALYSIS:** (a) The relationship between the shape factor and thermal resistance of a shape follows from their definitions in terms of heat rates and overall temperature differences.

$$q = kS\Delta T \quad (4.20), \quad q = \frac{\Delta T}{R_t} \quad (3.19), \quad S = 1/kR_t \quad (4.21)$$

Using the thermal resistance relations developed in Chapter 3, their corresponding shape factors are:

*Plane wall:*



$$R_t = \frac{L}{kA} \quad S = \frac{A}{L} \quad <$$

*Cylindrical shell:*

$$R_t = \frac{\ln(r_2/r_1)}{2\pi Lk} \quad S = \frac{2\pi L}{\ln r_2/r_1} \quad <$$

( $L$  into the page)

*Spherical shell:*

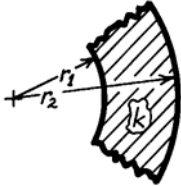

$$R_t = \frac{1}{4\pi k} \left[ \frac{1}{r_1} - \frac{1}{r_2} \right] \quad S = \frac{4\pi}{1/r_1 - 1/r_2} \quad <$$

(b) The shape factor for the sphere of diameter  $D$  in an infinite medium can be derived using the alternative conduction analysis of Section 3.2. For this situation,  $q_r$  is a constant and Fourier's law has the form

$$q_r = -k(4\pi r^2) \frac{dT}{dr}$$

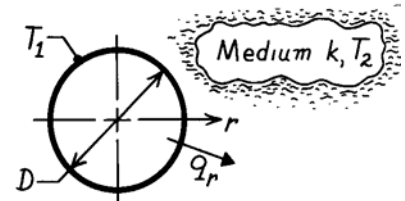

Separate variables, identify limits and integrate.

$$-\frac{q_r}{4\pi k} \int_{D/2}^{\infty} \frac{dr}{r^2} = \int_{T_1}^{T_2} dT \quad -\frac{q_r}{4\pi k} \left[ -\frac{1}{r} \right]_{D/2}^{\infty} = -\frac{q_r}{4\pi k} \left[ 0 - \frac{2}{D} \right] = (T_2 - T_1)$$

$$q_r = 4\pi k \left[ \frac{D}{2} \right] (T_1 - T_2) \quad \text{or} \quad S = 2\pi D. \quad <$$

**COMMENTS:** Note that the result for the buried sphere,  $S = 2\pi D$ , can be obtained from the expression for the spherical shell with  $r_2 = \infty$ . Also, the shape factor expression for the "isothermal sphere buried in a semi-infinite medium" presented in Table 4.1 provides the same result with  $z \rightarrow \infty$ .

## PROBLEM 4.7

**KNOWN:** Diameters and temperatures of horizontal circular cylinders. Eccentricity factor. Heat transfer rate per unit length. Fluid thermal conductivity.

**FIND:** Effective thermal conductivity.

**SCHEMATIC:**

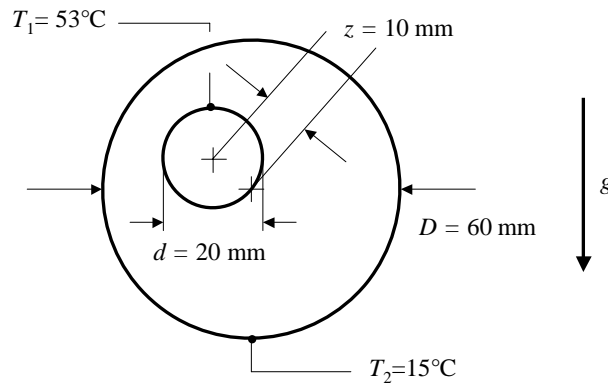

**ASSUMPTIONS:** (1) Constant properties, (2) Steady state conditions.

**PROPERTIES:** Given:  $k = 0.255 \text{ W/m}\cdot\text{K}$ .

**ANALYSIS:** In the absence of free convection the conduction heat transfer per unit length may be found by using the shape factor expression and applying Case 7 of Table 4.1. Hence

$$\begin{aligned}
 \dot{q}_{\text{cond}} &= \frac{S}{L} k (T_1 - T_2) = \frac{2\pi k (T_1 - T_2)}{\cosh^{-1} \left( \frac{D^2 + d^2 - 4z^2}{2Dd} \right)} = \frac{2\pi \times 0.255 \text{ W/m}\cdot\text{K} (53 - 15)^\circ\text{C}}{\cosh^{-1} \left( \frac{(60 \times 10^{-3} \text{ m})^2 + (20 \times 10^{-3} \text{ m})^2 - 4 \times (10 \times 10^{-3} \text{ m})^2}{2 \times 60 \times 10^{-3} \text{ m} \times 20 \times 10^{-3} \text{ m}} \right)} \\
 &= 63.3 \text{ W/m}
 \end{aligned}$$

The free convection heat transfer rate is

$$\dot{q}_{\text{conv}} = \frac{S}{L} k_{\text{eff}} (T_1 - T_2) = 110 \text{ W/m}$$

Therefore the effective thermal conductivity is

$$k_{\text{eff}} = k \frac{\dot{q}_{\text{conv}}}{\dot{q}_{\text{cond}}} = 0.255 \text{ W/m}\cdot\text{K} \cdot \frac{110 \text{ W/m}}{63.3 \text{ W/m}} = 0.44 \text{ W/m}\cdot\text{K} \quad <$$

**COMMENTS:** Buoyancy-induced fluid motion increases the heat transfer rate between the cylinders by 74%.

## PROBLEM 4.8

**KNOWN:** Boundary conditions on four sides of a square plate.

**FIND:** Expressions for shape factors associated with the *maximum* and *average* top surface temperatures. Values of these shape factors. The maximum and average temperatures for specified conditions.

**SCHEMATIC:**

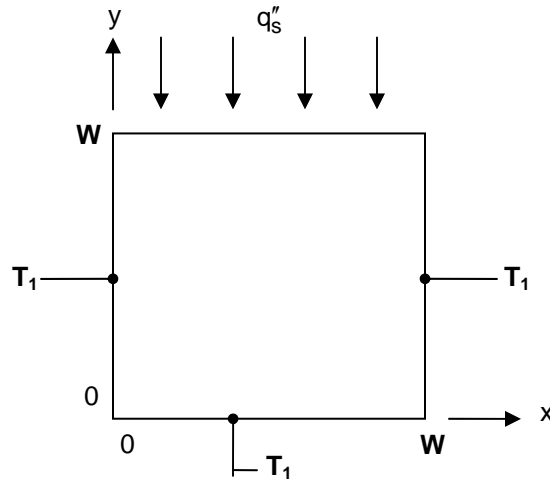

**ASSUMPTIONS:** (1) Two-dimensional, steady-state conduction, (2) Constant properties.

**ANALYSIS:** We must first find the temperature distribution as in Problem 4.5. Problem 4.5 differs from the problem solved in Section 4.2 only in the boundary condition at the top surface. Defining  $\theta = T - T_\infty$ , the differential equation and boundary conditions are

$$\frac{\partial^2 \theta}{\partial x^2} + \frac{\partial^2 \theta}{\partial y^2} = 0$$

$$\theta(0, y) = 0 \quad \theta(L, y) = 0 \quad \theta(x, 0) = 0 \quad k \frac{\partial \theta}{\partial y} \Big|_{y=W} = q_s'' \quad (1a,b,c,d)$$

The solution is identical to that in Section 4.2 through Equation (4.11),

$$\theta = \sum_{n=1}^{\infty} C_n \sin \frac{n\pi x}{L} \sinh \frac{n\pi y}{L} \quad (2)$$

To determine  $C_n$ , we now apply the top surface boundary condition, Equation (1d). Differentiating Equation (2) yields

$$\frac{\partial \theta}{\partial y} \Big|_{y=W} = \sum_{n=1}^{\infty} C_n \frac{n\pi}{L} \sin \frac{n\pi x}{L} \cosh \frac{n\pi W}{L} \quad (3)$$

Continued ...

### PROBLEM 4.8 (Cont.)

Substituting this into Equation (1d) results in

$$\frac{q_s''}{k} = \sum_{n=1}^{\infty} A_n \sin \frac{n\pi x}{L} \quad (4)$$

where  $A_n = C_n(n\pi/L)\cosh(n\pi W/L)$ . The principles expressed in Equations (4.13) through (4.16) still apply, but now with reference to Equation (4) and Equation (4.14), we should choose

$f(x) = q_s''/k$ ,  $g_n(x) = \sin \frac{n\pi x}{L}$ . Equation (4.16) then becomes

$$A_n = \frac{\frac{q_s''}{k} \int_0^L \sin \frac{n\pi x}{L} dx}{\int_0^L \sin^2 \frac{n\pi x}{L} dx} = \frac{q_s''}{k} \frac{2(-1)^{n+1} + 1}{\pi n}$$

Thus

$$C_n = 2 \frac{q_s'' L}{k} \frac{(-1)^{n+1} + 1}{n^2 \pi^2 \cosh(n\pi W/L)} \quad (5)$$

The solution is given by Equation (2) with  $C_n$  defined by Equation (5). We now proceed to evaluate the shape factors.

(a) The maximum top surface temperature occurs at the midpoint of that surface,  $x = W/2$ ,  $y = W$ . From Equation (2) with  $L = W$ ,

$$\theta(W/2, W) = T_{2,\max} - T_1 = \sum_{n=1}^{\infty} C_n \sin \frac{n\pi}{2} \sinh n\pi = \sum_{n \text{ odd}} C_n (-1)^{(n-1)/2} \sinh n\pi$$

where

$$C_n = 2 \frac{q_s'' W}{k} \frac{(-1)^{n+1} + 1}{n^2 \pi^2 \cosh n\pi}$$

Thus

$$S_{\max} = \frac{q_s'' W d}{k(T_{2,\max} - T_1)} = \left[ \frac{2}{d} \sum_{n \text{ odd}} \frac{(-1)^{n+1} + 1}{n^2 \pi^2} (-1)^{(n-1)/2} \tanh n\pi \right]^{-1} = \left[ \frac{4}{d} \sum_{n \text{ odd}} \frac{(-1)^{(n-1)/2}}{n^2 \pi^2} \tanh n\pi \right]^{-1} <$$

where  $d$  is the depth of the rectangle into the page.

Continued...

**PROBLEM 4.8 (Cont.)**

(b) The average top surface temperature is given by

$$\bar{\theta}(y = W) = \bar{T}_2 - T_1 = \sum_{n=1}^{\infty} C_n \frac{1}{W} \int_0^W \sin \frac{n\pi x}{W} dx \sinh n\pi = \sum_{n=1}^{\infty} C_n \frac{1 - (-1)^n}{n\pi} \sinh n\pi$$

Thus

$$\bar{S} = \frac{q_s'' W d}{k(\bar{T}_2 - T_1)} = \left[ \frac{2}{d} \sum_{n=1}^{\infty} \frac{[(-1)^{n+1} + 1][1 - (-1)^n]}{n^3 \pi^3} \tanh n\pi \right]^{-1} = \left[ \frac{8}{d} \sum_{n \text{ odd}} \frac{1}{n^3 \pi^3} \tanh n\pi \right]^{-1} \quad <$$

(c) Evaluating the expressions for the shape factors yields

$$\frac{S_{\max}}{d} = \left[ 4 \sum_{n \text{ odd}} \frac{(-1)^{(n-1)/2}}{n^2 \pi^2} \tanh n\pi \right]^{-1} = 2.70 \quad <$$

$$\frac{\bar{S}}{d} = \left[ 8 \sum_{n \text{ odd}} \frac{1}{n^3 \pi^3} \tanh n\pi \right]^{-1} = 3.70 \quad <$$

The temperatures can then be found from

$$T_{2,\max} = T_1 + \frac{q}{S_{\max} k} = T_1 + \frac{q_s'' W d}{S_{\max} k} = 0^\circ\text{C} + \frac{1000 \text{ W/m}^2 \times 0.01 \text{ m}}{2.70 \times 20 \text{ W/m} \cdot \text{K}} = 0.19^\circ\text{C} \quad <$$

$$\bar{T}_2 = T_1 + \frac{q}{\bar{S} k} = T_1 + \frac{q_s'' W d}{\bar{S} k} = 0^\circ\text{C} + \frac{1000 \text{ W/m}^2 \times 0.01 \text{ m}}{3.70 \times 20 \text{ W/m} \cdot \text{K}} = 0.14^\circ\text{C} \quad <$$

### PROBLEM 4.9

**KNOWN:** Heat generation in a buried spherical container.

**FIND:** (a) Outer surface temperature of the container, (b) Representative isotherms and heat flow lines.

**SCHEMATIC:**



**ASSUMPTIONS:** (1) Steady-state conditions, (2) Soil is a homogeneous medium with constant properties.

**PROPERTIES:** Table A-3, Soil (300K):  $k = 0.52 \text{ W/m}\cdot\text{K}$ .

**ANALYSIS:** (a) From an energy balance on the container,  $q = \dot{E}_g$  and from the first entry in Table 4.1,

$$q = \frac{2\pi D}{1 - D/4z} k(T_1 - T_2).$$

Hence,

$$T_1 = T_2 + \frac{q}{k} \frac{1 - D/4z}{2\pi D} = 20^\circ\text{C} + \frac{500\text{W}}{0.52 \frac{\text{W}}{\text{m}\cdot\text{K}}} \frac{1 - 2\text{m}/40\text{m}}{2\pi(2\text{m})} = 92.7^\circ\text{C} \quad <$$

(b) The isotherms may be viewed as spherical surfaces whose center moves downward with increasing radius. The surface of the soil is an isotherm for which the center is at  $z = \infty$ .

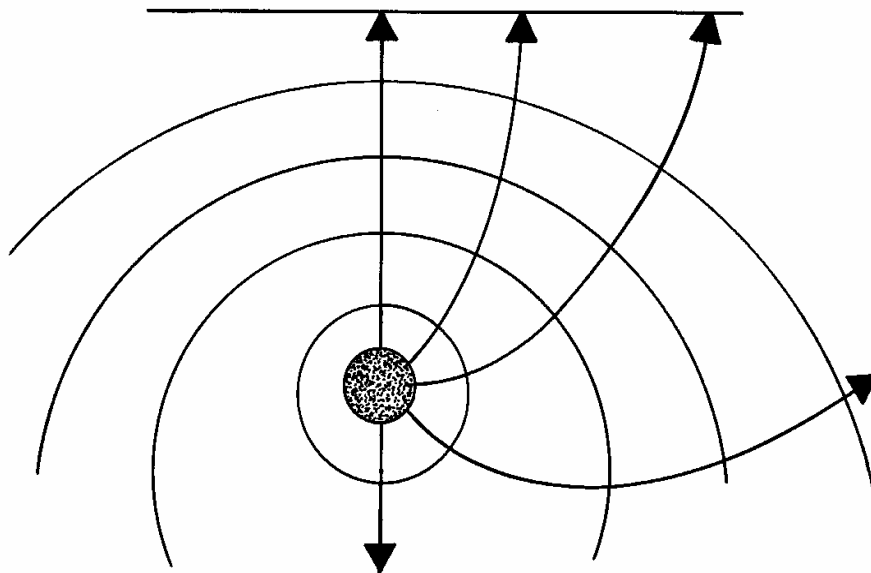

### PROBLEM 4.10

**KNOWN:** Shape of objects at surface of semi-infinite medium.

**FIND:** Shape factors between object at temperature  $T_1$  and semi-infinite medium at temperature  $T_2$ .

**SCHEMATIC:**

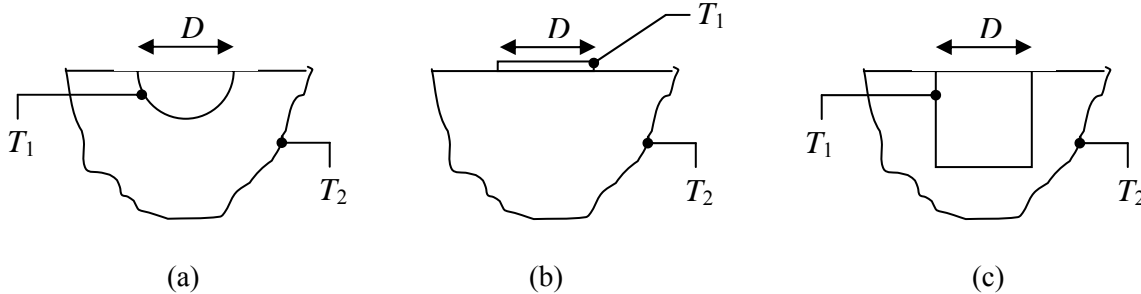

**ASSUMPTIONS:** (1) Steady-state, (2) Medium is semi-infinite, (3) Constant properties, (4) Surface of semi-infinite medium is adiabatic.

**ANALYSIS:** Cases 12 -15 of Table 4.1 all pertain to objects buried in an infinite medium. Since they all possess symmetry about a horizontal plane that bisects the object, they are equivalent to the cases given in this problem for which the horizontal plane is adiabatic. In particular, the heat flux is the same for the cases of this problem as for the cases of Table 4.1. Note, that when we use Table 4.1 to determine the dimensionless conduction heat rate,  $q_{ss}^*$ , we must be consistent and use the surface area of the “entire” object of Table 4.1, not the “half” object of this problem. Then

$$q'' = \frac{q}{A_s} = \frac{q_{ss}^* k (T_1 - T_2)}{L_c}$$

where  $L_c = (A_s/4\pi)^{1/2}$  and  $A_s$  is the area given in Table 4.1

When we calculate the shape factors we must account for the fact that the surface areas and heat transfer rates for the objects of this problem are half as much as for the objects of Table 4.1.

$$S = \frac{q}{k(T_1 - T_2)} = \frac{q'' A_s/2}{k(T_1 - T_2)} = \frac{q_{ss}^* A_s}{2L_c} = \frac{q_{ss}^* (4\pi A_s)^{1/2}}{2}$$

where  $A_s$  is still the area in table 4.1 and the 2 in the denominator accounts for the area being halved. Thus, finally,

$$S = q_{ss}^* (\pi A_s)^{1/2}$$

$$(a) \quad S = 1 \cdot (\pi \cdot \pi D^2)^{1/2} = \pi D \quad <$$

$$(b) \quad S = \frac{2\sqrt{2}}{\pi} \left( \pi \cdot \frac{\pi D^2}{2} \right)^{1/2} = 2D \quad <$$

This agrees with Table 4.1a, Case 10.

$$(c) \quad S = 0.932(\pi \cdot 2D^2)^{1/2} = \sqrt{2\pi}(0.932)D = 2.34D \quad <$$

(d) The height of the “whole object” is  $d = 2D$ . Thus

$$S = 0.961 \left[ \pi (2D^2 + 4D \cdot 2D) \right]^{1/2} = \sqrt{10\pi}(0.961)D = 5.39D \quad <$$

## PROBLEM 4.11

**KNOWN:** Diameters and temperatures of spherical particles that are in contact.

**FIND:** Heat transfer rate.

**SCHEMATIC:**

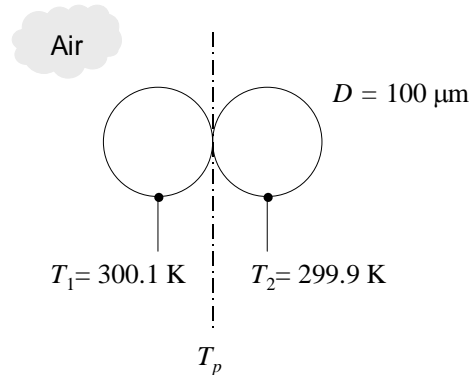

**ASSUMPTIONS:** (1) Constant properties, (2) Isothermal particles.

**PROPERTIES:** Table A.4, Air (300 K):  $k = 0.0263 \text{ W/m}\cdot\text{K}$ .

**ANALYSIS:** By symmetry, the vertical plane at the particle contact point is at temperature  $T_p = (T_1 + T_2)/2 = 300 \text{ K}$ . Therefore, conduction between the particles  $q_{12}$  is equal to conduction from particle 1 to the plane,  $q_{1p} = Sk(T_1 - T_p)$ . The shape factor is that of Case 1 of Table 4.1 evaluated at  $z = D/2$  yielding  $S = 4\pi D$ . Therefore,

$$q_{12} = q_{1p} = 4\pi Dk \left( T_1 - \frac{T_1 + T_2}{2} \right) = 4\pi \times 100 \times 10^{-6} \text{ m} \times 0.0263 \text{ W/m}\cdot\text{K} \times 0.1 \text{ K} = 3.3 \times 10^{-6} \text{ W} = 3.3 \mu\text{W} <$$

**COMMENTS:** (1) The air thermal conductivity in the vicinity of the contact point would be reduced by nanoscale effects such as those described in Chapter 2. In applying the shape factor of Case 1 of Table 4.1 to the  $z = D/2$  situation we have implicitly assumed that nanoscale effects are negligible. See B. Gebhart, *Heat Conduction and Mass Diffusion*, McGraw-Hill, 1993 for an appropriate treatment of nanoscale phenomena for this geometry. (2) The effective thermal conductivity of porous media composed of high thermal conductivity particles, such as packed metal powder layers, may be estimated by accounting for the particle size and packing distribution and using an analysis such as the one presented here.



## PROBLEM 4.12

**KNOWN:** Dimensions of a two-dimensional object, applied boundary conditions and thermal conductivity.

**FIND:** (a) Shape factor for the object if the dimensions are  $a = 10$  mm,  $b = 12$  mm. (b) Shape factor for  $a = 10$  mm,  $b = 15$  mm. (c) Shape factor for cases (a) and (b) using the alternative conduction analysis (d) For  $T_1 = 100^\circ\text{C}$  and  $T_2 = 60^\circ\text{C}$ , determine the heat transfer rate per unit depth for  $k = 15$  W/m·K for cases (a) and (b).

**SCHEMATIC:**

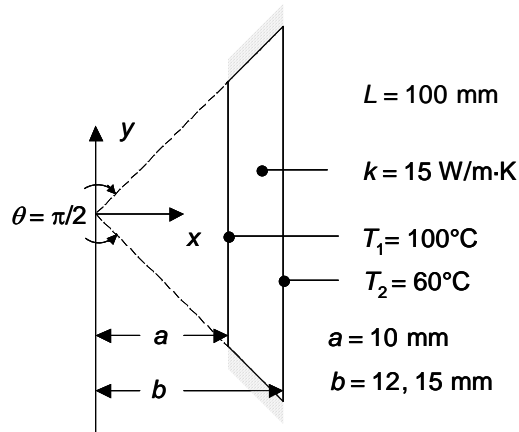

**ASSUMPTIONS:** (1) Steady-state conditions, (2) Constant properties.

**PROPERTIES:** Given:  $k = 15$  W/m·K.

**ANALYSIS:** (a) The geometry and applied boundary conditions correspond to Case 11 of Table 4.1(a). Noting that the diagonals of the square channel of Case 11 are adiabats, the shape factor for  $b/a = W/w = 12/10 = 1.2$  is one-fourth the shape factor given in Table 4.1(a),

$$S = 0.25 \times \frac{2\pi L}{0.785 \ln(W/w)} = \frac{2.00L}{\ln(W/w)} = \frac{2.00 \times 0.10\text{m}}{\ln(1.2)} = 1.097 \quad <$$

(b) For  $b/a = W/w = 15/10 = 1.5$ ,

$$S = 0.25 \times \frac{2\pi L}{0.930 \ln(W/w) - 0.050} = \frac{1.69L}{\ln(W/w) - 0.0534} = \frac{1.69 \times 0.10\text{m}}{\ln(1.5) - 0.0534} = 0.480 \quad <$$

(c) From the one-dimensional alternative conduction analysis with the top surface described by  $y = x$  and  $A = 2yL$ ,

$$q_x = -kA \frac{dT}{dx} = -2kLx \frac{dT}{dx}$$

Separating variables and integrating yields

$$\int_{x=a}^b \frac{dx}{x} = -\frac{2kL}{q_x} \int_{T_1}^{T_2} dT \quad \text{or} \quad \ln(b/a) = \frac{2kL}{q_x} (T_1 - T_2)$$

Hence,  $S_{1-D} = 2L/[\ln(b/a)]$ .

Continued...

### PROBLEM 4.12 (Cont.)

For  $b/a = 1.2$ ,  $S_{1-D} = 2 \times 0.1\text{m}/[\ln(1.2)] = 1.097$ . For  $b/a = 1.5$ ,  $S_{1-D} = 2 \times 0.1\text{m}/[\ln(1.5)] = 0.493$ . <

As  $b/a$  becomes small, the influence of the lateral edges is diminished and one-dimensional conditions are approached. Hence, the shape factor estimated using the one-dimensional alternative conduction solution is nearly the same as for the two-dimensional shape factor for  $b/a = 1.2$ . As  $b/a$  is increased, the lateral edge effects become more important, and the shape factors obtained by the two methods begin to diverge in value. As two-dimensional conduction in the object becomes more pronounced, the heat transfer rate is decreased relative to that associated with the assumed one-dimensional conditions.

(d) For  $b/a = 1.2$ , the heat transfer rate is

$$q = Sk(T_1 - T_2) = 1.097 \times 15 \text{ W/m} \cdot \text{K} \times (100 - 60)^\circ\text{C} = 658 \text{ W} \quad <$$

for  $b/a = 1.5$ , the heat transfer rate is

$$q = Sk(T_1 - T_2) = 0.480 \times 15 \text{ W/m} \cdot \text{K} \times (100 - 60)^\circ\text{C} = 288 \text{ W} \quad <$$

**COMMENTS:** The heat transfer rate is independent of the individual values of  $a$  or  $b$ . As either  $b$  or  $a$  is increased while maintaining a fixed  $b/a$  ratio, the cross-sectional area for heat transfer increases, but the increase is offset by increased thickness through which the conduction occurs. The offsetting effects balance one another, and the net result is no change in the heat transfer rate.

### PROBLEM 4.13

**KNOWN:** Electrical heater of cylindrical shape inserted into a hole drilled normal to the surface of a large block of material with prescribed thermal conductivity.

**FIND:** Temperature reached when heater dissipates 50 W with the block at 25°C.

**SCHEMATIC:**

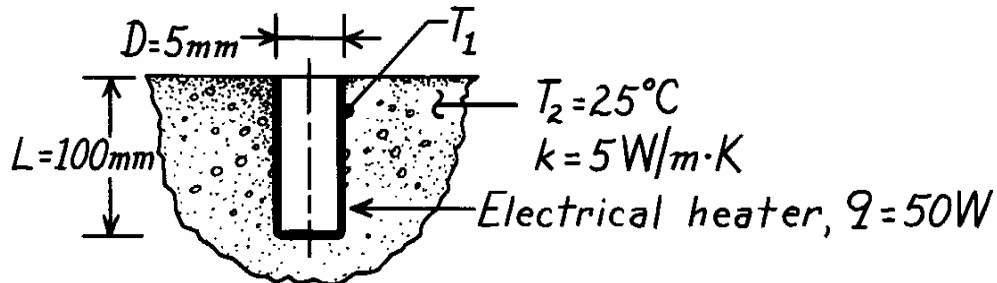

**ASSUMPTIONS:** (1) Steady-state conditions, (2) Block approximates semi-infinite medium with constant properties, (3) Negligible heat loss to surroundings above block surface, (4) Heater can be approximated as isothermal at  $T_1$ .

**ANALYSIS:** The temperature of the heater surface follows from the rate equation written as

$$T_1 = T_2 + q/kS$$

where  $S$  can be estimated from the conduction shape factor given in Table 4.1 for a “vertical cylinder in a semi-infinite medium,”

$$S = 2\pi L / \ln(4L/D).$$

Substituting numerical values, find

$$S = 2\pi \times 0.1\text{ m} / \ln\left[\frac{4 \times 0.1\text{ m}}{0.005\text{ m}}\right] = 0.143\text{ m}.$$

The temperature of the heater is then

$$T_1 = 25^\circ\text{C} + 50\text{ W} / (5\text{ W/m}\cdot\text{K} \times 0.143\text{ m}) = 94.9^\circ\text{C}. \quad \leftarrow$$

**COMMENTS:** (1) Note that the heater has  $L \gg D$ , which is a requirement of the shape factor expression.

(2) Our calculation presumes there is negligible thermal contact resistance between the heater and the medium. In practice, this would not be the case unless a conducting paste were used.

(3) Since  $L \gg D$ , assumption (3) is reasonable.

(4) This configuration has been used to determine the thermal conductivity of materials from measurement of  $q$  and  $T_1$ .

### PROBLEM 4.14

**KNOWN:** Surface temperatures of two parallel pipe lines buried in soil.

**FIND:** Heat transfer per unit length between the pipe lines.

**SCHEMATIC:**

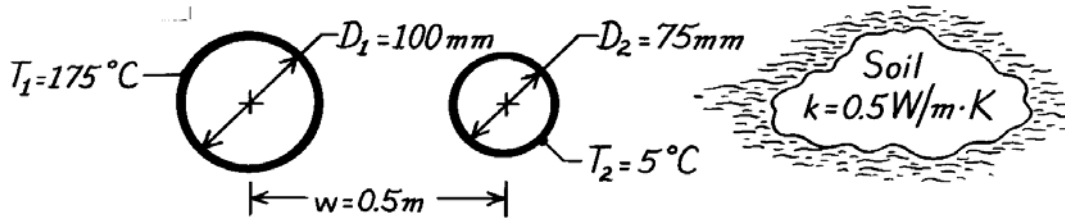

**ASSUMPTIONS:** (1) Steady-state conditions, (2) Two-dimensional conduction, (3) Constant properties, (4) Pipe lines are buried very deeply, approximating burial in an infinite medium, (5) Pipe length  $\gg D_1$  or  $D_2$  and  $w > D_1$  or  $D_2$ .

**ANALYSIS:** The heat transfer rate per unit length from the hot pipe to the cool pipe is

$$q' = \frac{q}{L} = \frac{S}{L} k (T_1 - T_2).$$

The shape factor  $S$  for this configuration is given in Table 4.1 as

$$S = \frac{2\pi L}{\cosh^{-1} \left[ \frac{4w^2 - D_1^2 - D_2^2}{2D_1 D_2} \right]}.$$

Substituting numerical values,

$$\frac{S}{L} = 2\pi / \cosh^{-1} \left[ \frac{4 \times (0.5\text{m})^2 - (0.1\text{m})^2 - (0.075\text{m})^2}{2 \times 0.1\text{m} \times 0.075\text{m}} \right] = 2\pi / \cosh^{-1}(65.63)$$

$$\frac{S}{L} = 2\pi / 4.88 = 1.29.$$

Hence, the heat rate per unit length is

$$q' = 1.29 \times 0.5 \text{ W/m}\cdot\text{K} (175 - 5)^\circ\text{C} = 110 \text{ W/m.} \quad <$$

**COMMENTS:** The heat gain to the cooler pipe line will be larger than 110 W/m if the soil temperature is greater than  $5^\circ\text{C}$ . How would you estimate the heat gain if the soil were at  $25^\circ\text{C}$ ?

## PROBLEM 4.15

**KNOWN:** Dimensions and temperature of water droplet.

**FIND:** Time for droplet to freeze completely.

**SCHEMATIC:**

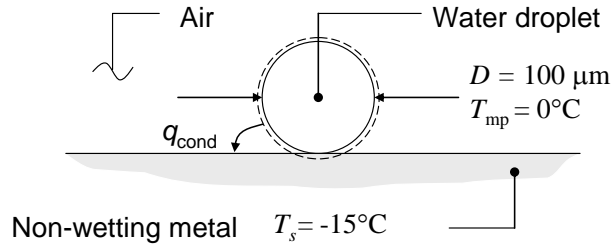

**ASSUMPTIONS:** (1) Constant properties, (2) Negligible convection and radiation, (3) Isothermal water particle, (4) Semi-infinite medium.

**PROPERTIES:** Table A.4, Air (265 K):  $k_a = 0.0235 \text{ W/m}\cdot\text{K}$ . Table A.6, Liquid water (273 K):  $\rho_w = 1000 \text{ kg/m}^3$ .

**ANALYSIS:** An energy balance on the droplet yields

$$t = \frac{\Delta E}{q_{\text{cond}}} = \frac{V \rho_w h_{\text{sf}}}{Sk(T_{\text{mp}} - T_s)} \quad (1)$$

The shape factor  $S$  is that of Case 1 of Table 4.1 with  $z = D/2$

$$S = \frac{2\pi D}{1 - D/4z} = 4\pi D \quad (2)$$

Combining Equations (1) and (2) with the expression for the droplet volume  $V = \pi D^3/6$  yields

$$t = \frac{D^2 \rho_w h_{\text{sf}}}{24k_a(T_{\text{mp}} - T_s)} = \frac{(100 \times 10^{-6} \text{ m})^2 \times 1000 \text{ kg/m}^3 \times 334,000 \text{ J/kg}}{24 \times 0.0235 \text{ W/m}\cdot\text{K} \times 15 \text{ K}} = 0.39 \text{ s} \quad <$$

**COMMENTS:** (1) Solidification might initiate in the lower region of the droplet. The ice that forms would pose an additional conduction resistance between the cold metal surface and the liquid water. This would increase the time needed for the droplet to solidify completely. (2) The air thermal conductivity in the vicinity of the contact point would be reduced by the nanoscale effects described in Chapter 2. In applying this shape factor for the  $z = D/2$  case we have implicitly assumed that nanoscale effects are negligible. See B. Gebhart, *Heat Conduction and Mass Diffusion*, McGraw-Hill, 1993.

### PROBLEM 4.16

**KNOWN:** Tube embedded in the center plane of a concrete slab.

**FIND:** The shape factor and heat transfer rate per unit length using the appropriate tabulated relation,

**SCHEMATIC:**

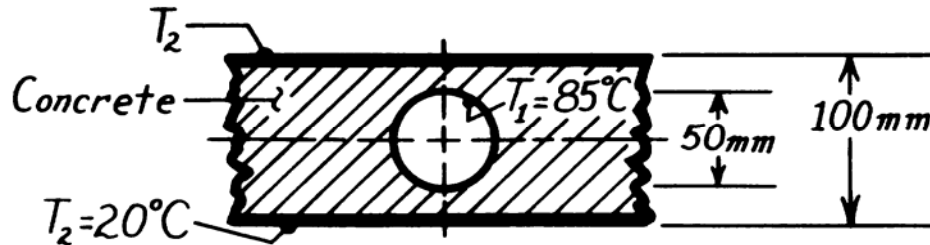

**ASSUMPTIONS:** (1) Two-dimensional conduction, (2) Steady-state conditions, (3) Constant properties, (4) Concrete slab infinitely long in horizontal plane,  $L \gg z$ .

**PROPERTIES:** Table A-3, Concrete, stone mix (300K):  $k = 1.4 \text{ W/m}\cdot\text{K}$ .

**ANALYSIS:** If we relax the restriction that  $z \gg D/2$ , the embedded tube-slab system corresponds to the fifth case of Table 4.1. Hence,

$$S = \frac{2\pi L}{\ln(8z/\pi D)}$$

where  $L$  is the length of the system normal to the page,  $z$  is the half-thickness of the slab and  $D$  is the diameter of the tube. Substituting numerical values, find

$$S = 2\pi L / \ln(8 \times 50\text{mm} / \pi 50\text{mm}) = 6.72L.$$

Hence, the heat rate per unit length is

$$q' = \frac{q}{L} = \frac{S}{L} k (T_1 - T_2) = 6.72 \times 1.4 \frac{\text{W}}{\text{m}\cdot\text{K}} (85 - 20)^\circ \text{C} = 612 \text{ W}.$$

### PROBLEM 4.17

**KNOWN:** Dimensions and boundary temperatures of a steam pipe embedded in a concrete casing.

**FIND:** Heat loss per unit length.

**SCHEMATIC:**

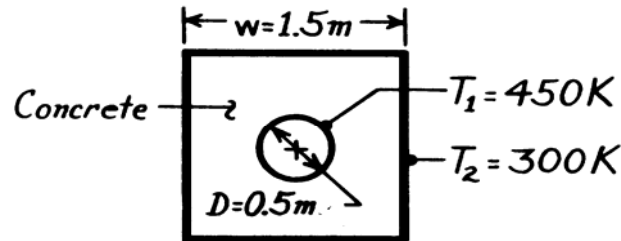

**ASSUMPTIONS:** (1) Steady-state conditions, (2) Negligible steam side convection resistance, pipe wall resistance and contact resistance ( $T_1 = 450\text{ K}$ ), (3) Constant properties.

**PROPERTIES:** Table A-3, Concrete (300K):  $k = 1.4\text{ W/m}\cdot\text{K}$ .

**ANALYSIS:** The heat rate can be expressed as

$$q = Sk\Delta T_{1-2} = Sk(T_1 - T_2)$$

From Table 4.1, the shape factor is

$$S = \frac{2\pi L}{\ln\left[\frac{1.08 w}{D}\right]}$$

Hence,

$$q' = \left[\frac{q}{L}\right] = \frac{2\pi k(T_1 - T_2)}{\ln\left[\frac{1.08 w}{D}\right]}$$

$$q' = \frac{2\pi \times 1.4\text{ W/m}\cdot\text{K} \times (450 - 300)\text{ K}}{\ln\left[\frac{1.08 \times 1.5\text{ m}}{0.5\text{ m}}\right]} = 1122\text{ W/m.}$$

<

**COMMENTS:** Having neglected the steam side convection resistance, the pipe wall resistance, and the contact resistance, the foregoing result overestimates the actual heat loss.

## PROBLEM 4.18

**KNOWN:** Power, size and shape of laser beam. Material properties.

**FIND:** Maximum surface temperature for a Gaussian beam, maximum temperature for a flat beam, and average temperature for a flat beam.

**SCHEMATIC:**

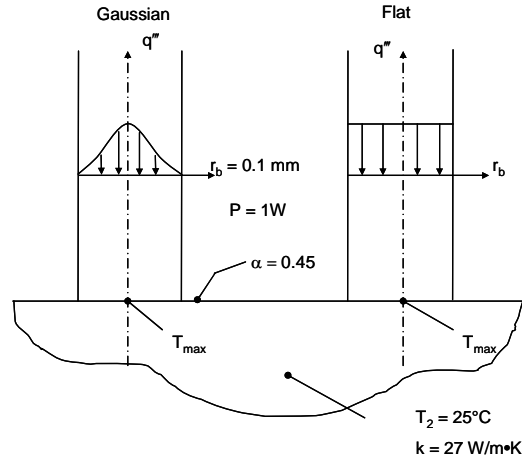

**ASSUMPTIONS:** (1) Steady-state conditions, (2) Constant properties, (3) Semi-infinite medium, (4) Negligible heat loss from the top surface.

**ANALYSIS:** The shape factor is defined in Eq. 4.20 and is  $q = Sk\Delta T_{1-2}$  (1)

From the problem statement and Section 4.3, the shape factors for the three cases are:

Beam Shape	Shape Factor	$T_{1,avg}$ or $T_{1,max}$
Gaussian	$2\sqrt{\pi}r_b$	$T_{1,max}$
Flat	$\pi r_b$	$T_{1,max}$
Flat	$3\pi^2 r_b / 8$	$T_{1,avg}$

For the Gaussian beam,  $S_1 = 2\sqrt{\pi} \times 0.1 \times 10^{-3} \text{ m} = 354 \times 10^{-6} \text{ m}$

For the flat beam (max. temperature),  $S_2 = \pi \times 0.1 \times 10^{-3} \text{ m} = 314 \times 10^{-6} \text{ m}$

For the flat beam (avg. temperature),  $S_3 = (3/8) \times \pi^2 \times 0.1 \times 10^{-3} \text{ m} = 370 \times 10^{-6} \text{ m}$

The temperature at the heated surface for the three cases is evaluated from Eq. (1) as

$$T_1 = T_2 + q/Sk = T_2 + P\alpha/Sk$$

For the Gaussian beam,  $T_{1,max} = 25^\circ\text{C} + 1 \text{ W} \times 0.45 / (354 \times 10^{-6} \text{ m} \times 27 \text{ W/m}\cdot\text{K}) = 72.1^\circ\text{C} <$

For the flat beam ( $T_{max}$ ),  $T_{1,max} = 25^\circ\text{C} + 1 \text{ W} \times 0.45 / (314 \times 10^{-6} \text{ m} \times 27 \text{ W/m}\cdot\text{K}) = 78.1^\circ\text{C} <$

For the flat beam ( $T_{avg}$ ),  $T_{1,avg} = 25^\circ\text{C} + 1 \text{ W} \times 0.45 / (370 \times 10^{-6} \text{ m} \times 27 \text{ W/m}\cdot\text{K}) = 70.0^\circ\text{C} <$

**COMMENTS:** (1) The maximum temperature occurs at  $r = 0$  for all cases. For the flat beam, the maximum temperature exceeds the average temperature by  $78.1 - 70.0 = 8.1$  degrees Celsius.



### PROBLEM 4.19

**KNOWN:** Thin-walled copper tube enclosed by an eccentric cylindrical shell; intervening space filled with insulation.

**FIND:** Heat loss per unit length of tube; compare result with that of a concentric tube-shell arrangement.

**SCHEMATIC:**

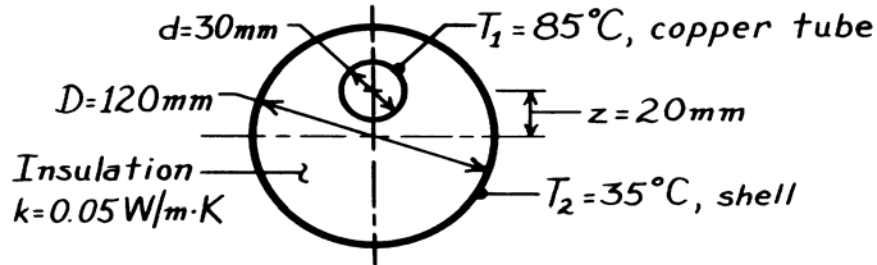

**ASSUMPTIONS:** (1) Steady-state conditions, (2) Constant properties, (3) Thermal resistances of copper tube wall and outer shell wall are negligible, (4) Two-dimensional conduction in insulation.

**ANALYSIS:** The heat loss per unit length written in terms of the shape factor  $S$  is

$q' = k(S/\ell)(T_1 - T_2)$  and from Table 4.1 for this geometry,

$$\frac{S}{\ell} = 2\pi / \cosh^{-1} \left[ \frac{D^2 + d^2 - 4z^2}{2Dd} \right].$$

Substituting numerical values, all dimensions in mm,

$$\frac{S}{\ell} = 2\pi / \cosh^{-1} \left[ \frac{120^2 + 30^2 - 4(20)^2}{2 \times 120 \times 30} \right] = 2\pi / \cosh^{-1}(1.903) = 4.991.$$

Hence, the heat loss is

$$q' = 0.05 \text{ W/m} \cdot \text{K} \times 4.991 (85 - 35)^\circ \text{C} = 12.5 \text{ W/m.} \quad <$$

If the copper tube were concentric with the shell, but all other conditions were the same, the heat loss would be

$$q'_c = \frac{2\pi k (T_1 - T_2)}{\ln(D_2/D_1)}$$

using Eq. 3.27. Substituting numerical values,

$$q'_c = 2\pi \times 0.05 \frac{\text{W}}{\text{m} \cdot \text{K}} (85 - 35)^\circ \text{C} / \ln(120/30)$$

$$q'_c = 11.3 \text{ W/m.}$$

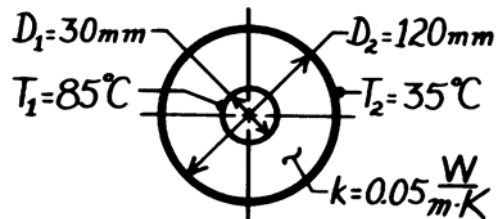

**COMMENTS:** As expected, the heat loss with the eccentric arrangement is larger than that for the concentric arrangement. The effect of the eccentricity is to increase the heat loss by  $(12.5 - 11.3)/11.3 \approx 11\%$ .

### PROBLEM 4.20

**KNOWN:** Cubical furnace, 350 mm external dimensions, with 50 mm thick walls.

**FIND:** The heat loss,  $q$ (W).

**SCHEMATIC:**

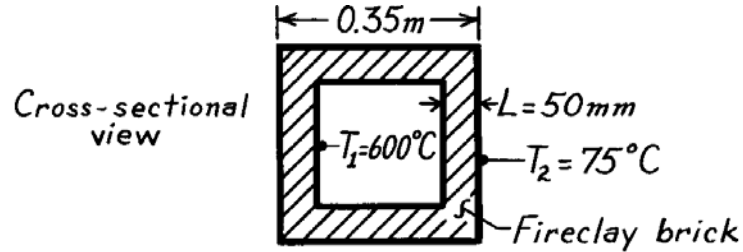

**ASSUMPTIONS:** (1) Steady-state conditions, (2) Two-dimensional conduction, (3) Constant properties.

**PROPERTIES:** Table A-3, Fireclay brick ( $\bar{T} = (T_1 + T_2)/2 = 610\text{K}$ ):  $k \approx 1.1 \text{ W/m}\cdot\text{K}$ .

**ANALYSIS:** Using relations for the shape factor from Table 4.1,

$$\text{Plane Walls (6)} \quad S_W = \frac{A}{L} = \frac{0.25 \times 0.25 \text{ m}^2}{0.05 \text{ m}} = 1.25 \text{ m}$$

$$\text{Edges (12)} \quad S_E = 0.54D = 0.54 \times 0.25 \text{ m} = 0.14 \text{ m}$$

$$\text{Corners (8)} \quad S_C = 0.15L = 0.15 \times 0.05 \text{ m} = 0.008 \text{ m}$$

The heat rate in terms of the shape factors is

$$q = kS(T_1 - T_2) = k(6S_W + 12S_E + 8S_C)(T_1 - T_2)$$

$$q = 1.1 \frac{\text{W}}{\text{m}\cdot\text{K}} (6 \times 1.25 \text{ m} + 12 \times 0.14 \text{ m} + 8 \times 0.008 \text{ m}) (600 - 75)^\circ \text{C}$$

$$q = 5.30 \text{ kW.}$$

<

**COMMENTS:** Note that the restrictions for  $S_E$  and  $S_C$  have been met.

## PROBLEM 4.21

**KNOWN:** Relation between maximum material temperature and its location, and scanning velocities.

**FIND:** (a) Required laser power to achieve a desired operating temperature for given material, beam size and velocity, (b) Lag distance separating the center of the beam and the location of maximum temperature, (c) Plot of the required laser power for velocities in the range  $0 \leq U \leq 2$  m/s.

**SCHEMATIC:**

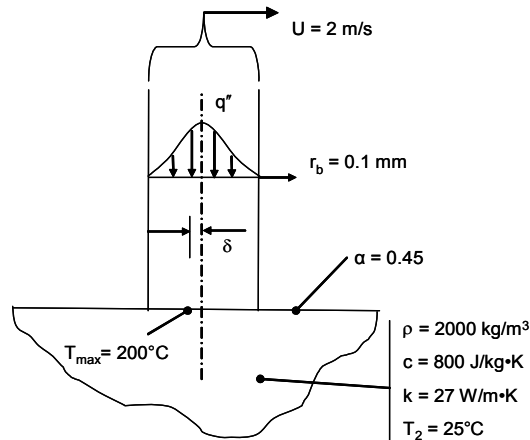

**ASSUMPTIONS:** (1) Steady-state conditions, (2) Constant properties, (3) Semi-infinite medium, (4) Negligible heat loss from the top surface.

**ANALYSIS:** The thermal diffusivity of the materials is

$$\alpha = k/\rho c = 27 \text{ W/m}\cdot\text{K} / (2000 \text{ kg/m}^3 \cdot 800 \text{ J/kg}\cdot\text{K}) = 16.9 \times 10^{-6} \text{ m}^2/\text{s}$$

(a) The Peclet number is

$$Pe = Ur_b / \sqrt{2}\alpha = 2 \text{ m/s} \times 0.0001 \text{ m} / (\sqrt{2} \times 16.9 \times 10^{-6} \text{ m}^2/\text{s}) = 8.38$$

Since this value of the Peclet number is within the range of the correlation provided in the problem statement, the maximum temperature corresponding to a stationary beam delivering the same power would be

$$\begin{aligned} T_{1,\max,U=0} &= (1 + 0.301Pe - 0.0108Pe^2) (T_{1,\max,U \neq 0} - T_2) + T_2 \\ &= (1 + 0.301 \times 8.37 - 0.0108 \times 8.37^2) \times (200 - 25)^\circ\text{C} + 25^\circ\text{C} \\ &= 509^\circ\text{C}. \end{aligned}$$

From Eq. 4.20 and Problem 4.18 we know that (with the symbol  $\hat{\alpha}$  now representing the absorptivity, since  $\alpha$  is used for thermal diffusivity)

Continued...

### PROBLEM 4.21 (Cont.)

$$P = Sk\Delta T_{1-2} / \hat{\alpha} = 2\sqrt{\pi}r_b k\Delta T_{1-2} / \hat{\alpha} = 2\sqrt{\pi} \times 0.0001 \text{ m} \times 27 \text{ W/m}\cdot\text{K} \times (509 - 25)^\circ\text{C} / 0.45$$
$$= 10.3 \text{ W} \quad <$$

(b) The lag distance is

$$\delta = 0.944 \frac{\alpha}{U} Pe^{1.55} = 0.944 \times \frac{16.9 \times 10^{-6} \text{ m}^2/\text{s}}{2 \text{ m/s}} \times 8.37^{1.55} = 0.21 \text{ mm} \quad <$$

(c) The plot of the required laser power versus scanning velocity is shown below.

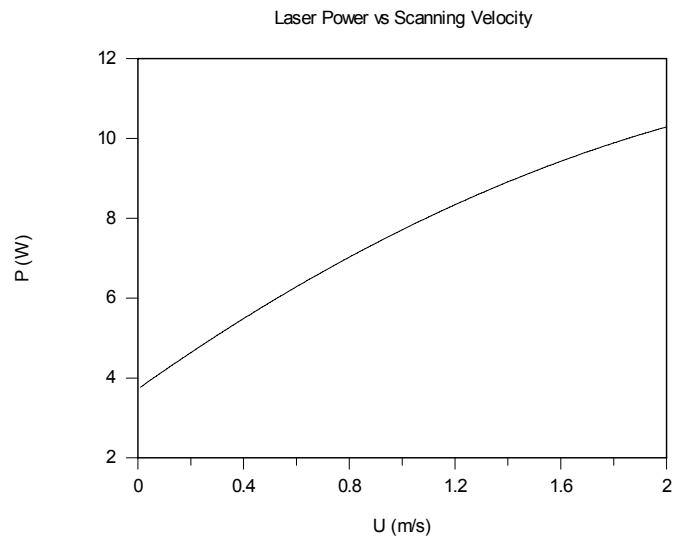

**COMMENTS:** (1) The required laser power increases as the scanning velocity increases since more material must be heated at higher scanning velocities. (2) The relative motion between the laser beam and the heated material represents an advection process. Advective effects will be dealt with extensively in Chapters 6 through 9.

## PROBLEM 4.22

**KNOWN:** Dimensions of stainless steel pillar and nominal glass temperatures. Contact resistance between pillar and glass.

**FIND:** Conduction rate through the pillar.

**SCHEMATIC:**

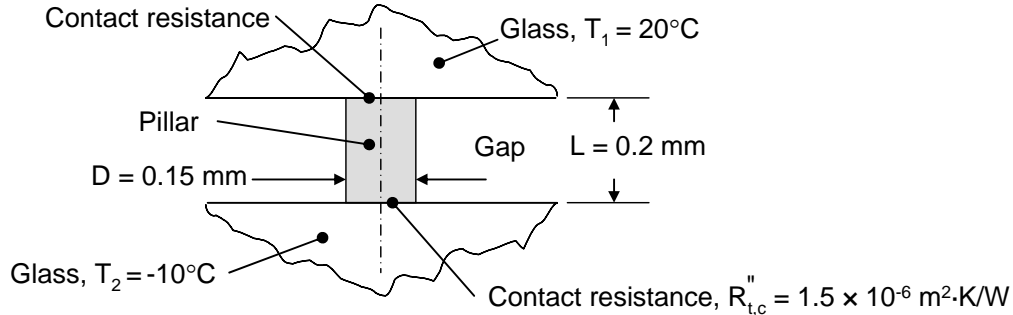

**ASSUMPTIONS:** (1) Steady-state conditions, (2) Constant properties, (3) Negligible radiation, (4) Two-dimensional conduction, (5) Glass behaves as a semi-infinite medium.

**PROPERTIES:** Table A.1, AISI 302 stainless steel (300 K):  $k_p = 15.1$  W/m·K. Table A.3, plate glass (300 K):  $k_g = 1.4$  W/m·K.

**ANALYSIS:** Conduction through the pillar results in a depression of the glass temperature adjacent to the pillar. This is associated with a *constriction resistance* within each glass sheet. Therefore, the resistance network consists of two constriction resistances, two contact resistances, and a conduction resistance through the pillar as shown below.

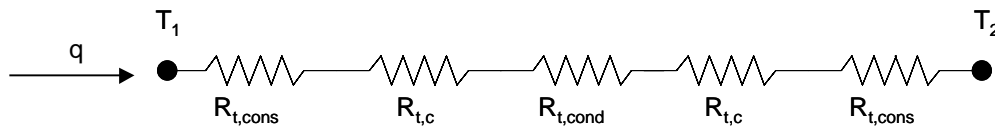

Using the shape factor for Case 10 of Table 4.1(a) the resistances are:

$$R_{t,cons} = 1/(Sk_g) = 1/(2Dk_g) = 1/(2 \times 0.15 \times 10^{-3} \text{ m} \times 1.4 \text{ W/m} \cdot \text{K}) = 2381 \text{ K/W}$$

$$R_{t,c} = R''_{t,c} / A_p = 1.5 \times 10^{-6} \text{ m}^2 \cdot \text{K/W} / \left[ \pi \times (0.15 \times 10^{-3} \text{ m})^2 / 4 \right] = 84.88 \text{ K/W}$$

$$R_{t,cond} = L/k_p A_p = L/k_p \left( \pi D_p^2 / 4 \right) = 0.2 \times 10^{-3} \text{ m} / \left[ 15.1 \text{ W/m} \cdot \text{K} \times \pi \times (0.15 \times 10^{-3} \text{ m})^2 / 4 \right] = 749.5 \text{ K/W}$$

Therefore, the total resistance is

$$R_{tot} = 2(R_{t,cons} + R_{t,c}) + R_{t,cond} = 2 \times (2381 \text{ K/W} + 84.88 \text{ K/W}) + 749.5 \text{ K/W} = 5681 \text{ K/W}$$

and the conduction through an individual pillar is

$$q = (T_1 - T_2)/R_{tot} = [20 - (-10)^\circ\text{C}]/[5681 \text{ K/W}] = 5.28 \times 10^{-3} \text{ W} = 5.28 \text{ mW} \quad \leftarrow$$

**COMMENTS:** (1) Constriction of the heat flow within the glass poses the largest resistance to heat transfer. (2) Radiation between the two glass sheets exists, and may be important in determining the overall heat transfer through the window. (3) Extremely high vacuum between the two glass sheets is required to eliminate conduction within the gap. (4) See Manz, Brunner and Wullschleger, "Triple Vacuum Glazing: Heat Transfer and Basic Design Constraints," *Solar Energy*, Vol. 80, pp. 1632-1642, 2006 for more information.

### PROBLEM 4.23

**KNOWN:** Temperature, diameter and burial depth of an insulated pipe.

**FIND:** Heat loss per unit length of pipe.

**SCHEMATIC:**

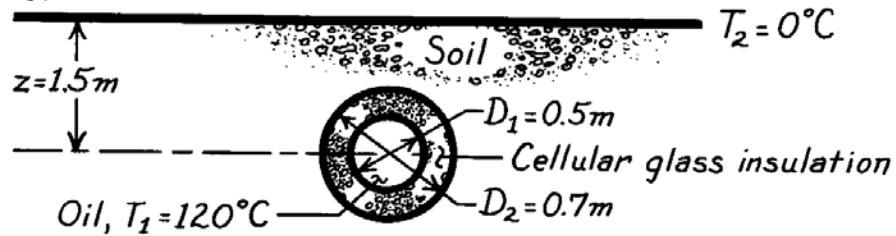

**ASSUMPTIONS:** (1) Steady-state conditions, (2) One-dimensional conduction through insulation, two-dimensional through soil, (3) Constant properties, (4) Negligible oil convection and pipe wall conduction resistances.

**PROPERTIES:** Table A-3, Soil (300K):  $k = 0.52 \text{ W/m}\cdot\text{K}$ ; Table A-3, Cellular glass (365K):  $k = 0.069 \text{ W/m}\cdot\text{K}$ .

**ANALYSIS:** The heat rate can be expressed as

$$q = \frac{T_1 - T_2}{R_{\text{tot}}}$$

where the thermal resistance is  $R_{\text{tot}} = R_{\text{ins}} + R_{\text{soil}}$ . From Equation 3.33,

$$R_{\text{ins}} = \frac{\ln(D_2/D_1)}{2\pi L k_{\text{ins}}} = \frac{\ln(0.7\text{m}/0.5\text{m})}{2\pi L \times 0.069 \text{ W/m}\cdot\text{K}} = \frac{0.776\text{m}\cdot\text{K/W}}{L}$$

From Equation 4.21 and Table 4.1,

$$R_{\text{soil}} = \frac{1}{S k_{\text{soil}}} = \frac{\cosh^{-1}(2z/D_2)}{2\pi L k_{\text{soil}}} = \frac{\cosh^{-1}(3/0.7)}{2\pi \times (0.52 \text{ W/m}\cdot\text{K})L} = \frac{0.653}{L} \text{m}\cdot\text{K/W}$$

Hence,

$$q = \frac{(120 - 0)^\circ\text{C}}{\frac{1}{L}(0.776 + 0.653) \frac{\text{m}\cdot\text{K}}{\text{W}}} = 84 \frac{\text{W}}{\text{m}} \times L$$

$$q' = q/L = 84 \text{ W/m.} \quad \leftarrow$$

**COMMENTS:** (1) Contributions of the soil and insulation to the total resistance are approximately the same. The heat loss may be reduced by burying the pipe deeper or adding more insulation.

(2) The convection resistance associated with the oil flow through the pipe may be significant, in which case the foregoing result would overestimate the heat loss. A calculation of this resistance may be based on results presented in Chapter 8.

(3) Since  $z > 3D/2$ , the shape factor for the soil can also be evaluated from  $S = 2\pi L / \ln(4z/D)$  of Table 4.1, and an equivalent result is obtained.

### PROBLEM 4.24

**KNOWN:** Operating conditions of a buried superconducting cable.

**FIND:** Required cooling load.

**SCHEMATIC:**

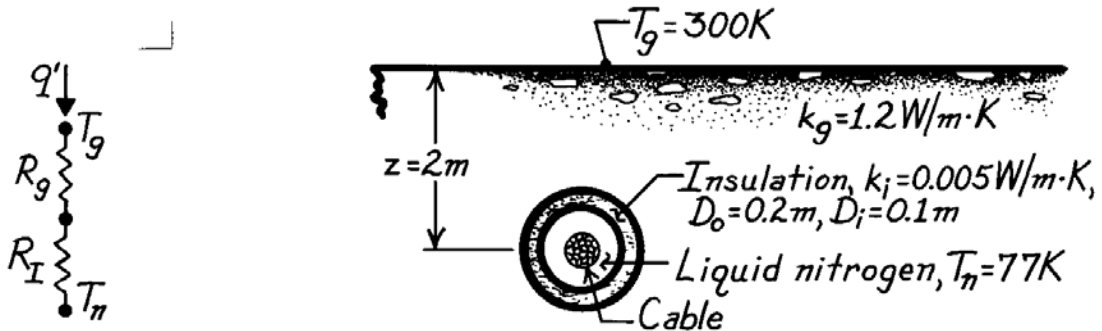

**ASSUMPTIONS:** (1) Steady-state conditions, (2) Constant properties, (3) Two-dimensional conduction in soil, (4) One-dimensional conduction in insulation, (5) Pipe inner surface is at liquid nitrogen temperature.

**ANALYSIS:** The heat rate per unit length is

$$q' = \frac{T_g - T_n}{R'_g + R'_I}$$

$$q' = \frac{T_g - T_n}{\left[ k_g \left( 2\pi / \ln(4z/D_o) \right) \right]^{-1} + \ln(D_o/D_i) / 2\pi k_i}$$

where Tables 3.3 and 4.1 have been used to evaluate the insulation and ground resistances, respectively. Hence,

$$q' = \frac{(300 - 77) \text{ K}}{\left[ (1.2 \text{ W/m} \cdot \text{K}) \left( 2\pi / \ln(8/0.2) \right) \right]^{-1} + \ln(2) / 2\pi \times 0.005 \text{ W/m} \cdot \text{K}}$$

$$q' = \frac{223 \text{ K}}{(0.489 + 22.064) \text{ m} \cdot \text{K/W}}$$

$$q' = 9.9 \text{ W/m.} \quad <$$

**COMMENTS:** The heat gain is small and the dominant contribution to the thermal resistance is made by the insulation.

## PROBLEM 4.25

**KNOWN:** Dimensions and temperature of thermocouple bead and wires. Manipulator temperature, distance between bead and surface.

**FIND:** Surface temperature.

**SCHEMATIC:**

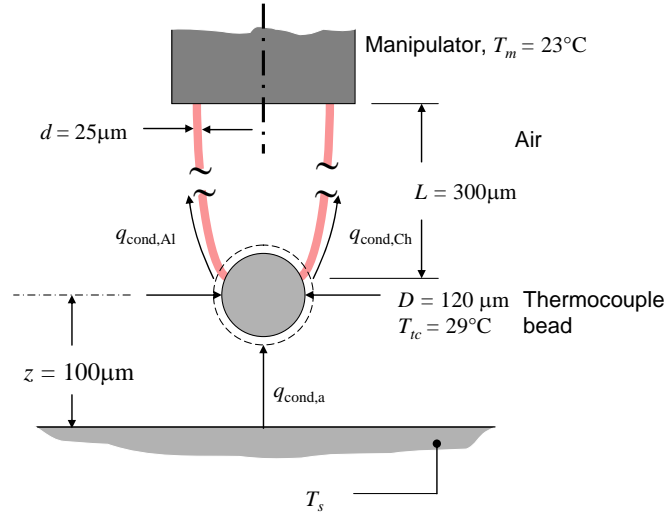

**ASSUMPTIONS:** (1) Constant properties, (2) Negligible radiation and convection, (3) Isothermal thermocouple bead, (4) Air behaves as a semi-infinite medium, (5) Steady state conditions.

**PROPERTIES:** Table A.4, Air (310 K):  $k_a = 0.027 \text{ W/m}\cdot\text{K}$ .

**ANALYSIS:** An energy balance on the thermocouple bead yields

$$q_{\text{cond,air}} = q_{\text{cond,Al}} + q_{\text{cond,Ch}} \quad (1)$$

where the conduction heat transfer rates through the alumel and chromel wires are denoted as  $q_{\text{cond,Al}}$  and  $q_{\text{cond,Ch}}$ , respectively. Conduction from the surface through the air to the thermocouple bead,  $q_{\text{cond,air}}$ , may be determined by use of the shape factor  $S = (2\pi D)/(1 - D/4z)$  of Case 1 of Table 4.1. Therefore, Equation (1) may be written as

$$Sk_a (T_s - T_{tc}) = k_{\text{Al}} \frac{\pi d^2}{4L} (T_{tc} - T_m) + k_{\text{Ch}} \frac{\pi d^2}{4L} (T_{tc} - T_m) \quad (2)$$

which may be rearranged to yield

$$\begin{aligned} T_s &= \frac{1 - D/4z}{2Dk_a} \cdot \frac{d^2}{4L} [k_{\text{Al}} (T_{tc} - T_m) + k_{\text{Ch}} (T_{tc} - T_m)] + T_{tc} \\ &= \frac{1 - 120/(4 \times 100)}{2 \times 120 \times 10^{-6} \text{ m} \times 0.027 \text{ W/m}\cdot\text{K}} \cdot \frac{(25 \times 10^{-6} \text{ m})^2}{4 \times 300 \times 10^{-6} \text{ m}} [29 \text{ W/m}\cdot\text{K} (29 - 23)^\circ\text{C} + 19 \text{ W/m}\cdot\text{K} (29 - 23)^\circ\text{C}] + 29^\circ\text{C} \\ &= 45.2^\circ\text{C} \end{aligned}$$

<

Continued...



### PROBLEM 4.25 (Cont.)

**COMMENTS:** The required surface temperature to induce the specified thermocouple temperature and its dependence on the separation distance,  $z$ , is shown below. As expected, the required surface temperature becomes greater as the separation distance increases.

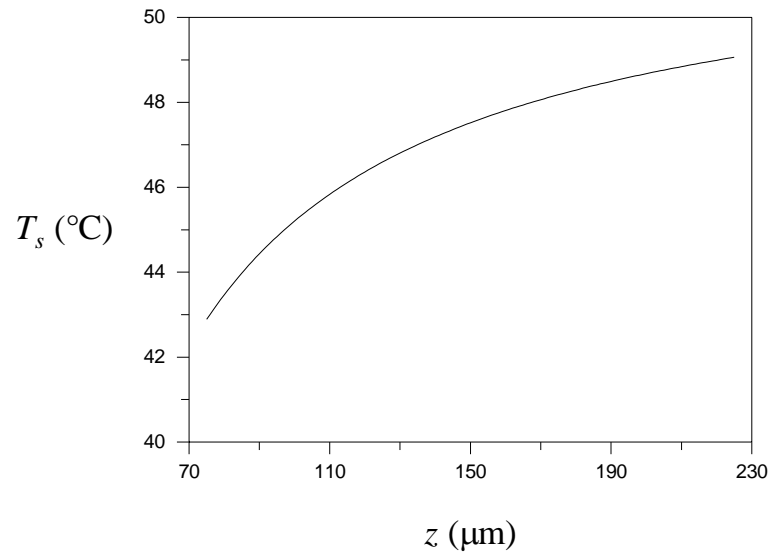

## PROBLEM 4.26

**KNOWN:** Dimensions, thermal conductivity and inner surface temperature of furnace wall. Ambient conditions.

**FIND:** Heat loss.

**SCHEMATIC:**

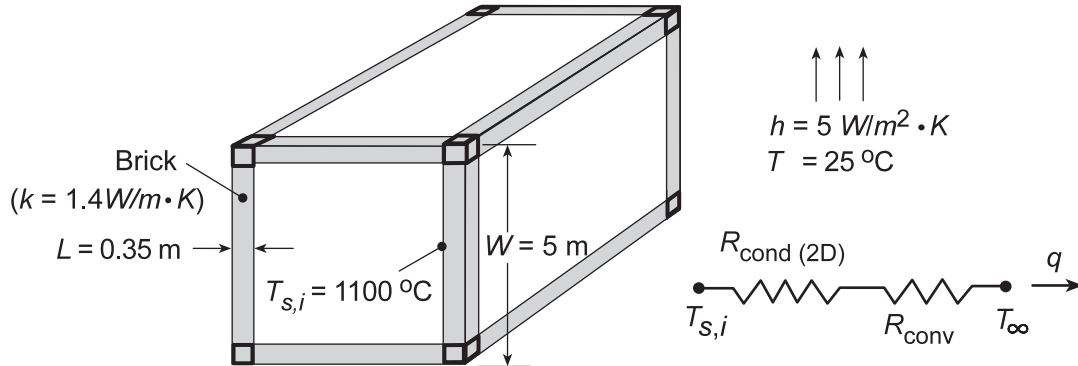

**ASSUMPTIONS:** (1) Steady-state, (2) Uniform convection coefficient over entire outer surface of container, (3) Negligible radiation losses.

**ANALYSIS:** From the thermal circuit, the heat loss is

$$q = \frac{T_{s,i} - T_{\infty}}{R_{\text{cond}(2D)} + R_{\text{conv}}}$$

where  $R_{\text{conv}} = 1/hA_{s,o} = 1/6(hW^2) = 1/6[5 \text{ W/m}^2 \cdot \text{K}(5 \text{ m})^2] = 0.00133 \text{ K/W}$ . From Equation (4.21), the two-dimensional conduction resistance is

$$R_{\text{cond}(2D)} = \frac{1}{Sk}$$

where the shape factor  $S$  must include the effects of conduction through the 8 corners, 12 edges and 6 plane walls. Hence, using the relations for Cases 8 and 9 of Table 4.1,

$$S = 8(0.15L) + 12 \times 0.54(W - 2L) + 6A_{s,i}/L$$

where  $A_{s,i} = (W - 2L)^2$ . Hence,

$$S = [8(0.15 \times 0.35) + 12 \times 0.54(4.30) + 6(52.83)] \text{ m}$$

$$S = (0.42 + 27.86 + 316.98) \text{ m} = 345.26 \text{ m}$$

and  $R_{\text{cond}(2D)} = 1/(345.26 \text{ m} \times 1.4 \text{ W/m} \cdot \text{K}) = 0.00207 \text{ K/W}$ . Hence

$$q = \frac{(1100 - 25)^\circ \text{C}}{(0.00207 + 0.00133) \text{ K/W}} = 316 \text{ kW} \quad \leftarrow$$

**COMMENTS:** The heat loss is extremely large and measures should be taken to insulate the furnace. Radiation losses may be significant, leading to larger heat losses.

### PROBLEM 4.27

**KNOWN:** Platen heated by passage of hot fluid in poor thermal contact with cover plates exposed to cooler ambient air.

**FIND:** (a) Heat rate per unit thickness from each channel,  $q'_i$ , (b) Surface temperature of cover plate,  $T_s$ , (c)  $q'_i$  and  $T_s$  if lower surface is perfectly insulated, (d) Effect of changing centerline spacing on  $q'_i$  and  $T_s$

**SCHEMATIC:**

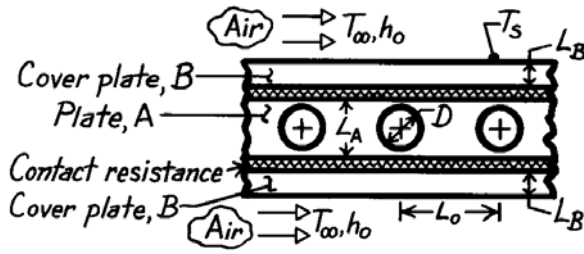

$$\begin{aligned}
 D &= 15 \text{ mm} & L_o &= 60 \text{ mm} \\
 L_A &= 30 \text{ mm} & L_B &= 7.5 \text{ mm} \\
 T_i &= 150^\circ\text{C} & h_i &= 1000 \text{ W/m}^2 \cdot \text{K} \\
 T_\infty &= 25^\circ\text{C} & h_o &= 200 \text{ W/m}^2 \cdot \text{K} \\
 k_A &= 20 \text{ W/m} \cdot \text{K} & k_B &= 75 \text{ W/m} \cdot \text{K} \\
 R''_{t,c} &= 2.0 \times 10^{-4} \text{ m}^2 \cdot \text{K/W}
 \end{aligned}$$

**ASSUMPTIONS:** (1) Steady-state conditions, (2) Two-dimensional conduction in platen, but one-dimensional in coverplate, (3) Temperature of interfaces between A and B is uniform, (4) Constant properties.

**ANALYSIS:** (a) The heat rate per unit thickness from each channel can be determined from the following thermal circuit representing the quarter section shown.

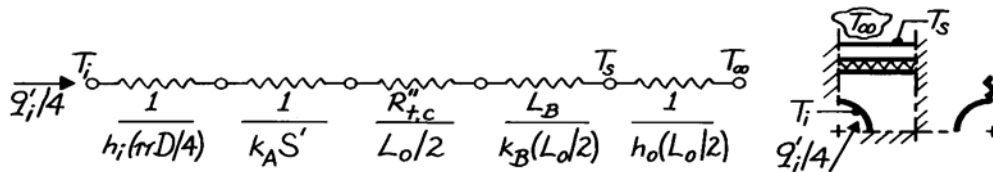

The value for the shape factor is  $S' = 1.06$  as determined from the flux plot shown on the next page. Hence, the heat rate is

$$q'_i = 4(T_i - T_\infty) / R'_{\text{tot}} \quad (1)$$

$$\begin{aligned}
 R'_{\text{tot}} &= [1/1000 \text{ W/m}^2 \cdot \text{K} (\pi 0.015\text{m}/4) + 1/20 \text{ W/m} \cdot \text{K} \times 1.06 \\
 &\quad + 2.0 \times 10^{-4} \text{ m}^2 \cdot \text{K/W} / (0.060\text{m}/2) + 0.0075\text{m}/75 \text{ W/m} \cdot \text{K} (0.060\text{m}/2) \\
 &\quad + 1/200 \text{ W/m}^2 \cdot \text{K} (0.060\text{m}/2)]
 \end{aligned}$$

$$\begin{aligned}
 R'_{\text{tot}} &= [0.085 + 0.047 + 0.0067 + 0.0033 + 0.1667] \text{ m} \cdot \text{K/W} \\
 R'_{\text{tot}} &= 0.309 \text{ m} \cdot \text{K/W}
 \end{aligned}$$

$$q'_i = 4(150 - 25) \text{ K} / 0.309 \text{ m} \cdot \text{K/W} = 1.62 \text{ kW/m.} \quad <$$

(b) The surface temperature of the cover plate also follows from the thermal circuit as

$$q'_i / 4 = \frac{T_s - T_\infty}{1/h_o (L_o/2)} \quad (2)$$

Continued ...

**PROBLEM 4.27 (Cont.)**

$$T_s = T_\infty + \frac{q'_i}{4 h_o (L_o/2)} = 25^\circ\text{C} + \frac{1.62 \text{ kW}}{4} \times 0.167 \text{ m} \cdot \text{K/W}$$

$$T_s = 25^\circ\text{C} + 67.6^\circ\text{C} \approx 93^\circ\text{C}.$$

<

(c,d) The effect of the centerline spacing on  $q'_i$  and  $T_s$  can be understood by examining the relative magnitudes of the thermal resistances. The dominant resistance is that due to the ambient air convection process which is inversely related to the spacing  $L_o$ . Hence, from Equation (1), the heat rate will increase nearly linearly with an increase in  $L_o$ ,

$$q'_i \sim \frac{1}{R'_{\text{tot}}} \approx \frac{1}{1/h_o (L_o/2)} \sim L_o.$$

From Eq. (2), find

$$\Delta T = T_s - T_\infty = \frac{q'_i}{4 h_o (L_o/2)} \sim q'_i \cdot L_o^{-1} \sim L_o \cdot L_o^{-1} \approx 1.$$

Hence we conclude that  $\Delta T$  will not increase with a change in  $L_o$ . Does this seem reasonable? What effect does  $L_o$  have on Assumptions (2) and (3)?

If the lower surface were insulated, the heat rate would be decreased nearly by half. This follows again from the fact that the overall resistance is dominated by the surface convection process. The temperature difference,  $T_s - T_\infty$ , would only increase slightly.

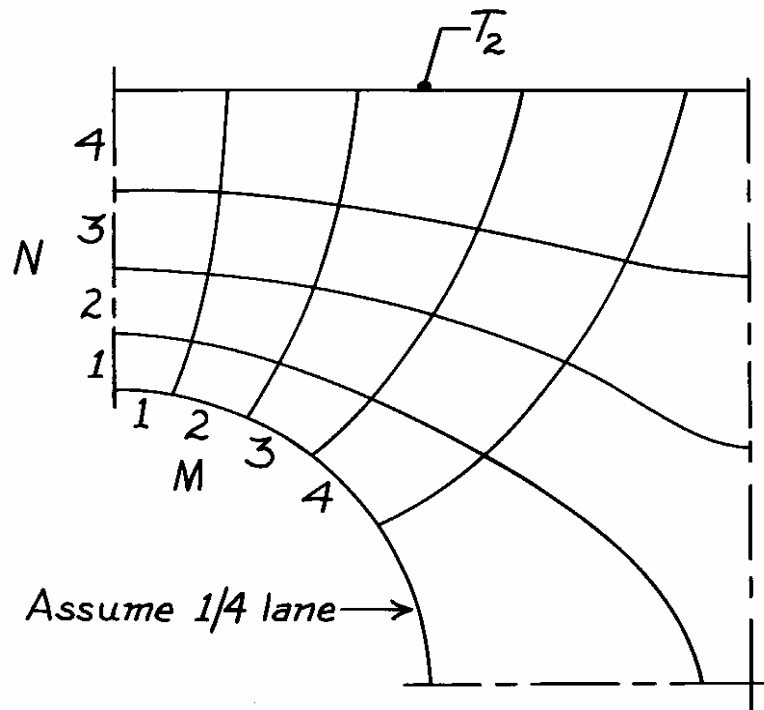

$$S' = S/l = M/N = 4.25/4 = 1.06$$

## PROBLEM 4.28

**KNOWN:** Dimensions and surface temperatures of a square channel. Number of chips mounted on outer surface and chip thermal contact resistance.

**FIND:** Heat dissipation per chip and chip temperature.

**SCHEMATIC:**

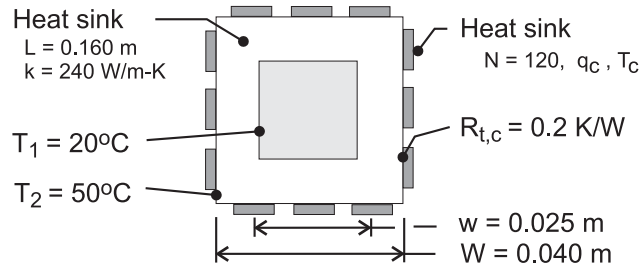

**ASSUMPTIONS:** (1) Steady state, (2) Approximately uniform channel inner and outer surface temperatures, (3) Two-dimensional conduction through channel wall (negligible end-wall effects), (4) Constant thermal conductivity.

**ANALYSIS:** The total heat rate is determined by the two-dimensional conduction resistance of the channel wall,  $q = (T_2 - T_1)/R_{t,cond(2D)}$ , with the resistance determined by using Equation 4.21 with Case 11 of Table 4.1. For  $W/w = 1.6 > 1.4$

$$R_{t,cond(2D)} = \frac{0.930 \ln(W/w) - 0.050}{2\pi L k} = \frac{0.387}{2\pi(0.160\text{m})240 \text{ W/m}\cdot\text{K}} = 0.00160 \text{ K/W}$$

The heat rate per chip is then

$$q_c = \frac{T_2 - T_1}{N R_{t,cond(2D)}} = \frac{(50 - 20)^\circ\text{C}}{120(0.0016 \text{ K/W})} = 156.3 \text{ W} \quad <$$

and, with  $q_c = (T_c - T_2)/R_{t,c}$ , the chip temperature is

$$T_c = T_2 + R_{t,c} q_c = 50^\circ\text{C} + (0.2 \text{ K/W})156.3 \text{ W} = 81.3^\circ\text{C} \quad <$$

**COMMENTS:** (1) By acting to *spread* heat flow lines away from a chip, the channel wall provides an excellent *heat sink* for dissipating heat generated by the chip. However, recognize that, in practice, there will be temperature variations on the inner and outer surfaces of the channel, and if the prescribed values of  $T_1$  and  $T_2$  represent minimum and maximum inner and outer surface temperatures, respectively, the rate is overestimated by the foregoing analysis. (2) The shape factor may also be determined by combining the expression for a plane wall with the result of Case 8 (Table 4.1). With  $S = [4(wL)/((W-w)/2)] + 4(0.54 L) = 2.479 \text{ m}$ ,  $R_{t,cond(2D)} = 1/(Sk) = 0.00168 \text{ K/W}$ .

## PROBLEM 4.29

**KNOWN:** Dimensions and thermal conductivity of concrete duct. Convection conditions of ambient air. Inlet temperature of water flow through the duct.

**FIND:** (a) Heat loss per duct length near inlet, (b) Minimum allowable flow rate corresponding to maximum allowable temperature rise of water.

**SCHEMATIC:**

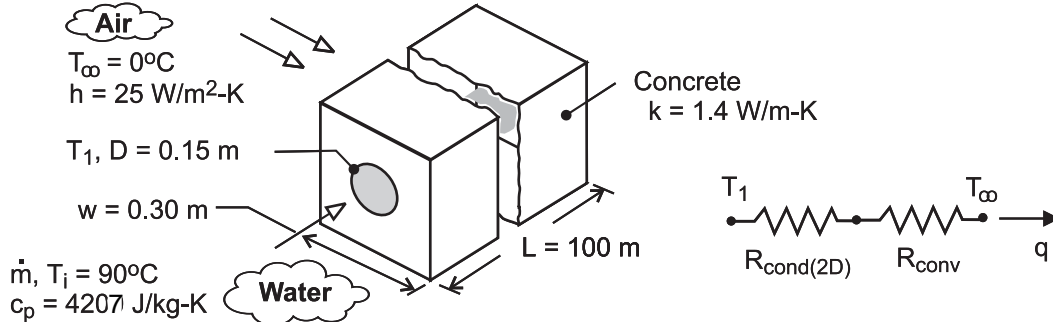

**ASSUMPTIONS:** (1) Steady state, (2) Negligible water-side convection resistance, pipe wall conduction resistance, and pipe/concrete contact resistance (temperature at inner surface of concrete corresponds to that of water), (3) Constant properties, (4) Negligible flow work and kinetic and potential energy changes.

**ANALYSIS:** (a) From the thermal circuit, the heat loss per unit length near the entrance is

$$q' = \frac{T_i - T_{\infty}}{R'_{\text{cond}}(2D) + R'_{\text{conv}}} = \frac{T_i - T_{\infty}}{\frac{\ln(1.08w/D)}{2\pi k} + \frac{1}{h(4w)}}$$

where  $R'_{\text{cond}}(2D)$  is obtained by using the shape factor of Case 6 from Table 4.1 with Eq. (4.21).

Hence,

$$q' = \frac{(90 - 0)^{\circ}\text{C}}{\frac{\ln(1.08 \times 0.30 / 0.15\text{m})}{2\pi(1.4 \text{ W/m} \cdot \text{K})} + \frac{1}{25 \text{ W/m}^2 \cdot \text{K}(1.2\text{m})}} = \frac{90^{\circ}\text{C}}{(0.0876 + 0.0333) \text{ K} \cdot \text{m/W}} = 745 \text{ W/m} \quad <$$

(b) From Eq. (1.12d), with  $q = q'L$  and  $(T_i - T_o) = 5^{\circ}\text{C}$ ,

$$\dot{m} = \frac{q'L}{u_i - u_o} = \frac{q'L}{c(T_i - T_o)} = \frac{745 \text{ W/m}(100\text{m})}{4207 \text{ J/kg} \cdot \text{K}(5^{\circ}\text{C})} = 3.54 \text{ kg/s} \quad <$$

**COMMENTS:** The small reduction in the temperature of the water as it flows from inlet to outlet induces a slight departure from two-dimensional conditions and a small reduction in the heat rate per unit length. A slightly conservative value (upper estimate) of  $\dot{m}$  is therefore obtained in part (b).

### PROBLEM 4.30

**KNOWN:** Long constantan wire butt-welded to a large copper block forming a thermocouple junction on the surface of the block.

**FIND:** (a) The measurement error  $(T_j - T_o)$  for the thermocouple for prescribed conditions, and (b) Compute and plot  $(T_j - T_o)$  for  $h = 5, 10$  and  $25 \text{ W/m}^2\cdot\text{K}$  for block thermal conductivity  $15 \leq k \leq 400 \text{ W/m}\cdot\text{K}$ . When is it advantageous to use smaller diameter wire?

**SCHEMATIC:**

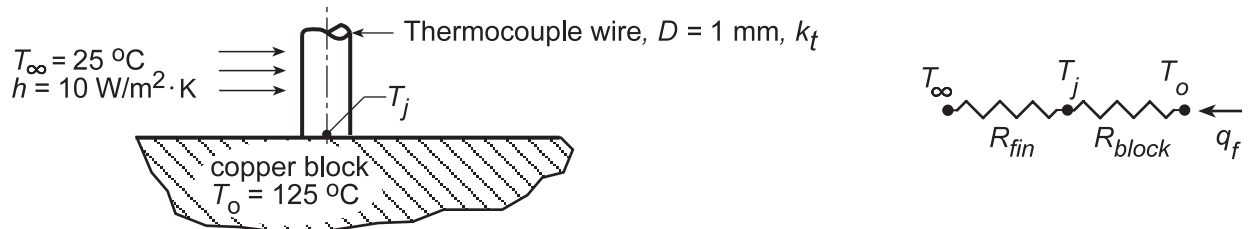

**ASSUMPTIONS:** (1) Steady-state conditions, (2) Thermocouple wire behaves as a fin with constant heat transfer coefficient, (3) Copper block has uniform temperature, except in the vicinity of the junction.

**PROPERTIES:** Table A-1, Copper (pure, 400 K),  $k_b = 393 \text{ W/m}\cdot\text{K}$ ; Constantan (350 K),  $k_t \approx 25 \text{ W/m}\cdot\text{K}$ .

**ANALYSIS:** The thermocouple wire behaves as a long fin permitting heat to flow from the surface thereby depressing the sensing junction temperature below that of the block  $T_o$ . In the block, heat flows into the circular region of the wire-block interface; the thermal resistance to heat flow within the block is approximated as a disk of diameter  $D$  on a semi-infinite medium ( $k_b, T_o$ ). The thermocouple-block combination can be represented by a thermal circuit as shown above. The thermal resistance of the fin follows from the heat rate expression for an infinite fin,  $R_{fin} = (hPk_tA_c)^{-1/2}$ .

From Table 4.1, the shape factor for the disk-on-a-semi-infinite medium is given as  $S = 2D$  and hence  $R_{block} = 1/k_bS = 1/2k_bD$ . From the thermal circuit,

$$T_o - T_j = \frac{R_{block}}{R_{fin} + R_{block}}(T_o - T_\infty) = \frac{1.27}{1273 + 1.27}(125 - 25)^\circ\text{C} \approx 0.001(125 - 25)^\circ\text{C} = 0.1^\circ\text{C} \ll$$

with  $P = \pi D$  and  $A_c = \pi D^2/4$  and the thermal resistances as

$$R_{fin} = \left( 10 \text{ W/m}^2 \cdot \text{K} (\pi/4) 25 \text{ W/m} \cdot \text{K} \times (1 \times 10^{-3} \text{ m})^3 \right)^{-1/2} = 1273 \text{ K/W}$$

$$R_{block} = (1/2) \times 393 \text{ W/m} \cdot \text{K} \times 10^{-3} \text{ m} = 1.27 \text{ K/W}.$$

(b) We keyed the above equations into the IHT workspace, performed a sweep on  $k_b$  for selected values of  $h$  and created the plot shown. When the block thermal conductivity is low, the error  $(T_o - T_j)$  is larger, increasing with increasing convection coefficient. A smaller diameter wire will be advantageous for low values of  $k_b$  and higher values of  $h$ .

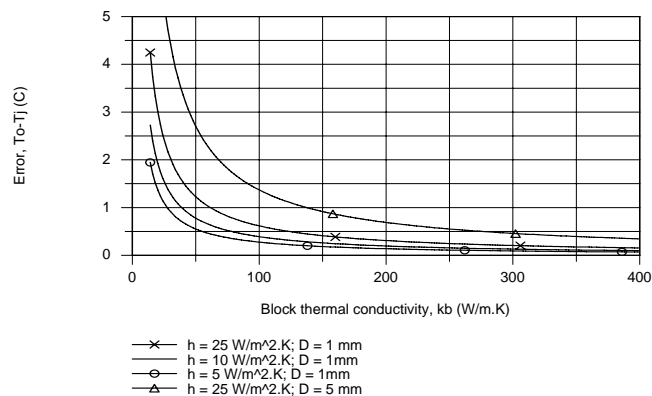

### PROBLEM 4.31

**KNOWN:** Dimensions, shape factor, and thermal conductivity of square rod with drilled interior hole. Interior and exterior convection conditions.

**FIND:** Heat rate and surface temperatures.

**SCHEMATIC:**

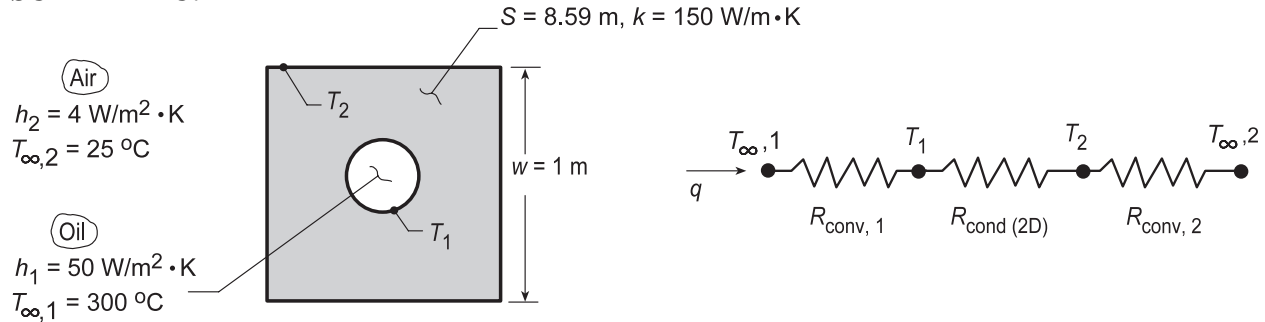

**ASSUMPTIONS:** (1) Steady-state, two-dimensional conduction, (2) Constant properties, (3) Uniform convection coefficients at inner and outer surfaces.

**ANALYSIS:** The heat loss can be expressed as

$$q = \frac{T_{\infty,1} - T_{\infty,2}}{R_{\text{conv},1} + R_{\text{cond}(2D)} + R_{\text{conv},2}}$$

where

$$R_{\text{conv},1} = (h_1 \pi D_1 L)^{-1} = (50 \text{ W/m}^2 \cdot \text{K} \times \pi \times 0.25 \text{ m} \times 2 \text{ m})^{-1} = 0.01273 \text{ K/W}$$

$$R_{\text{cond}(2D)} = (Sk)^{-1} = (8.59 \text{ m} \times 150 \text{ W/m} \cdot \text{K})^{-1} = 0.00078 \text{ K/W}$$

$$R_{\text{conv},2} = (h_2 \times 4wL)^{-1} = (4 \text{ W/m}^2 \cdot \text{K} \times 4 \text{ m} \times 1 \text{ m})^{-1} = 0.0625 \text{ K/W}$$

Hence,

$$q = \frac{(300 - 25)^\circ \text{C}}{0.076 \text{ K/W}} = 3.62 \text{ kW} \quad <$$

$$T_1 = T_{\infty,1} - qR_{\text{conv},1} = 300^\circ \text{C} - 46^\circ \text{C} = 254^\circ \text{C} \quad <$$

$$T_2 = T_{\infty,2} + qR_{\text{conv},2} = 25^\circ \text{C} + 226^\circ \text{C} = 251^\circ \text{C} \quad <$$

**COMMENTS:** The largest resistance is associated with convection at the outer surface, and the conduction resistance is much smaller than both convection resistances. Hence,  $(T_2 - T_{\infty,2}) > (T_{\infty,1} - T_1) \gg (T_1 - T_2)$ .



### PROBLEM 4.32

**KNOWN:** Long fin of aluminum alloy with prescribed convection coefficient attached to different base materials (aluminum alloy or stainless steel) with and without thermal contact resistance  $R''_{t,j}$  at the junction.

**FIND:** (a) Heat rate  $q_f$  and junction temperature  $T_j$  for base materials of aluminum and stainless steel, (b) Repeat calculations considering thermal contact resistance,  $R''_{t,j}$ , and (c) Plot as a function of  $h$  for the range  $10 \leq h \leq 1000 \text{ W/m}^2\cdot\text{K}$  for each base material.

**SCHEMATIC:**

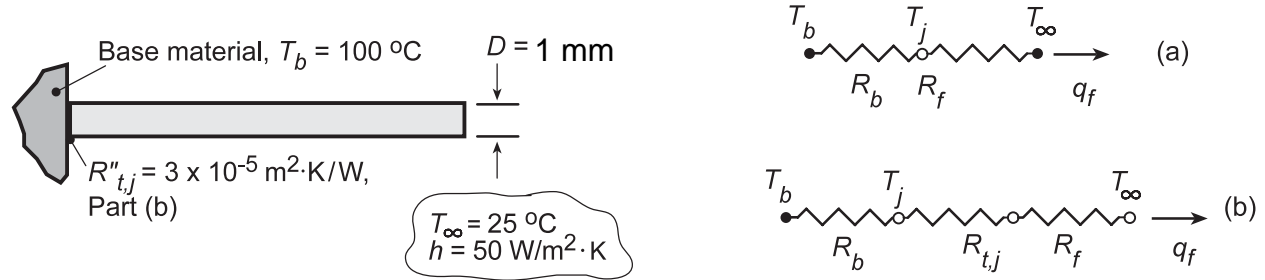

**ASSUMPTIONS:** (1) Steady-state conditions, (2) Constant properties, (3) Infinite fin.

**PROPERTIES:** (Given) Aluminum alloy,  $k = 240 \text{ W/m}\cdot\text{K}$ , Stainless steel,  $k = 15 \text{ W/m}\cdot\text{K}$ .

**ANALYSIS:** (a,b) From the thermal circuits, the heat rate and junction temperature are

$$q_f = \frac{T_b - T_\infty}{R_{\text{tot}}} = \frac{T_b - T_\infty}{R_b + R_{t,j} + R_f} \quad (1)$$

$$T_j = T_\infty + q_f R_f \quad (2)$$

and, with  $P = \pi D$  and  $A_c = \pi D^2/4$ , from Tables 4.1 and 3.4 find

$$R_b = 1/Sk_b = 1/(2Dk_b) = (2 \times 0.005 \text{ m} \times k_b)^{-1}$$

$$R_{t,j} = R''_{t,j}/A_c = 3 \times 10^{-5} \text{ m}^2 \cdot \text{K} / \text{W} / \left[ \pi (0.005 \text{ m})^2 / 4 \right] = 1.528 \text{ K/W}$$

$$R_f = (hPkA_c)^{-1/2} = \left[ 50 \text{ W/m}^2 \cdot \text{K} \pi^2 (0.005 \text{ m})^3 240 \text{ W/m}\cdot\text{K} / 4 \right]^{-1/2} = 16.4 \text{ K/W}$$

Base	$R_b$ (K/W)	Without $R''_{t,j}$		With $R''_{t,j}$	
		$q_f$ (W)	$T_j$ (°C)	$q_f$ (W)	$T_j$ (°C)
Al alloy	0.417	4.46	98.2	4.09	92.1
St. steel	6.667	3.26	78.4	3.05	75.1

(c) We used the *IHT Model for Extended Surfaces, Performance Calculations, Rectangular Pin Fin* to calculate  $q_f$  for  $10 \leq h \leq 100 \text{ W/m}^2\cdot\text{K}$  by replacing  $R''_{tc}$  (thermal resistance at fin base) by the sum of the contact and spreading resistances,  $R''_{t,j} + R''_b$ .

Continued...

### PROBLEM 4.32 (Cont.)

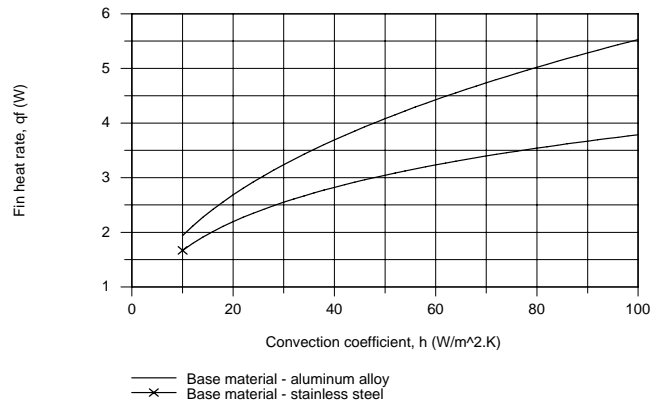

**COMMENTS:** (1) From part (a), the aluminum alloy base material has negligible effect on the fin heat rate and depresses the base temperature by only 2°C. The effect of the stainless steel base material is substantial, reducing the heat rate by 27% and depressing the junction temperature by 25°C.

(2) The contact resistance reduces the heat rate and increases the temperature depression relatively more with the aluminum alloy base.

(3) From the plot of  $q_f$  vs.  $h$ , note that at low values of  $h$ , the heat rates are nearly the same for both materials since the fin is the dominant resistance. As  $h$  increases, the effect of  $R_b''$  becomes more important.

### PROBLEM 4.33

**KNOWN:** Igloo constructed in hemispheric shape sits on ice cap; igloo wall thickness and inside/outside convection coefficients ( $h_i$ ,  $h_o$ ) are prescribed.

**FIND:** (a) Inside air temperature  $T_{\infty,i}$  when outside air temperature is  $T_{\infty,o} = -40^\circ\text{C}$  assuming occupants provide 320 W within igloo, (b) Perform parameter sensitivity analysis to determine which variables have significant effect on  $T_i$ .

**SCHEMATIC:**

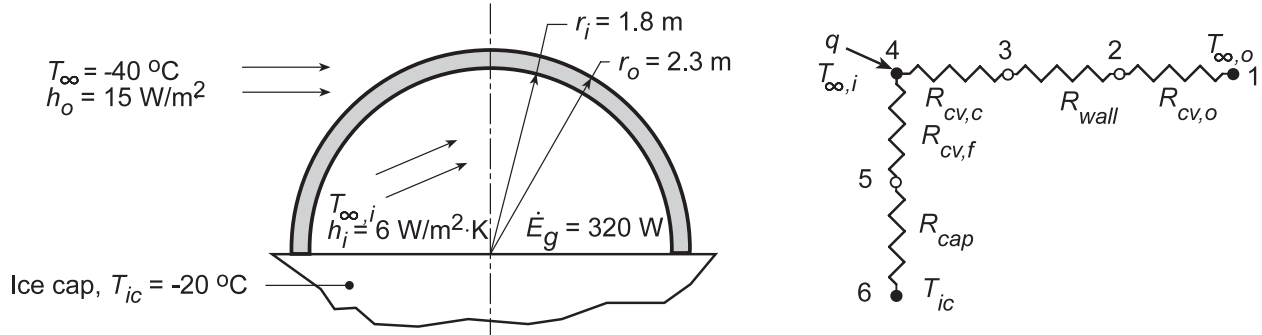

**ASSUMPTIONS:** (1) Steady-state conditions, (2) Convection coefficient is the same on floor and ceiling of igloo, (3) Floor and ceiling are at uniform temperatures, (4) Floor-ice cap resembles disk on semi-infinite medium, (5) One-dimensional conduction through igloo walls.

**PROPERTIES:** Ice and compacted snow (given):  $k = 0.15 \text{ W/m}\cdot\text{K}$ .

**ANALYSIS:** (a) The thermal circuit representing the heat loss from the igloo to the outside air and through the floor to the ice cap is shown above. The heat loss is

$$q = \frac{T_{\infty,i} - T_{\infty,o}}{R_{cv,c} + R_{wall} + R_{cv,o}} + \frac{T_{\infty,i} - T_{ic}}{R_{cv,f} + R_{cap}}$$

Convection, ceiling:  $R_{cv,c} = \frac{2}{h_i (4\pi r_i^2)} = \frac{2}{6 \text{ W/m}^2 \cdot \text{K} \times 4\pi (1.8 \text{ m})^2} = 0.00819 \text{ K/W}$

Convection, outside:  $R_{cv,o} = \frac{2}{h_o (4\pi r_o^2)} = \frac{2}{15 \text{ W/m}^2 \cdot \text{K} \times 4\pi (2.3 \text{ m})^2} = 0.00201 \text{ K/W}$

Convection, floor:  $R_{cv,f} = \frac{1}{h_i (\pi r_i^2)} = \frac{1}{6 \text{ W/m}^2 \cdot \text{K} \times \pi (1.8 \text{ m})^2} = 0.01637 \text{ K/W}$

Conduction, wall:  $R_{wall} = 2 \left[ \frac{1}{4\pi k} \left( \frac{1}{r_i} - \frac{1}{r_o} \right) \right] = 2 \left[ \frac{1}{4\pi \times 0.15 \text{ W/m}\cdot\text{K}} \left( \frac{1}{1.8} - \frac{1}{2.3} \right) \text{ m} \right] = 0.1281 \text{ K/W}$

Conduction, ice cap:  $R_{cap} = \frac{1}{kS} = \frac{1}{4kr_i} = \frac{1}{4 \times 0.15 \text{ W/m}\cdot\text{K} \times 1.8 \text{ m}} = 0.9259 \text{ K/W}$

where  $S$  was determined from the shape factor of Table 4.1. Hence,

$$q = 320 \text{ W} = \frac{T_{\infty,i} - (-40)^\circ\text{C}}{(0.00819 + 0.1281 + 0.00201) \text{ K/W}} + \frac{T_{\infty,i} - (-20)^\circ\text{C}}{(0.01637 + 0.9259) \text{ K/W}}$$

$$320 \text{ W} = 7.231(T_{\infty,i} + 40) + 1.06(T_{\infty,i} + 20) \quad T_{\infty,i} = 1.2^\circ\text{C}$$

<

Continued...

### PROBLEM 4.33 (Cont.)

(b) Begin the parameter sensitivity analysis to determine important variables which have a significant influence on the inside air temperature by examining the thermal resistances associated with the processes present in the system and represented by the network.

Process	Symbols		Value (K/W)
Convection, outside	$R_{cv,o}$	R21	0.0020
Conduction, wall	$R_{wall}$	R32	0.1281
Convection, ceiling	$R_{cv,c}$	R43	0.0082
Convection, floor	$R_{cv,f}$	R54	0.0164
Conduction, ice cap	$R_{cap}$	R65	0.9259

It follows that the convection resistances are negligible relative to the conduction resistance across the igloo wall. As such, only changes to the wall thickness will have an appreciable effect on the inside air temperature relative to the outside ambient air conditions. We don't want to make the igloo walls thinner and thereby allow the air temperature to dip below freezing for the prescribed environmental conditions.

Using the *IHT Thermal Resistance Network Model*, we used the circuit builder to construct the network and perform the energy balances to obtain the inside air temperature as a function of the outside convection coefficient for selected increased thicknesses of the wall.

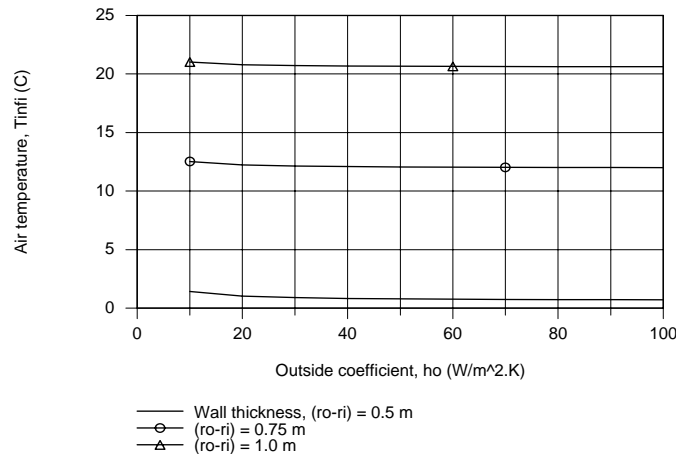

**COMMENTS:** (1) From the plot, we can see that the influence of the outside air velocity which controls the outside convection coefficient  $h_o$  is negligible.

(2) The thickness of the igloo wall is the dominant thermal resistance controlling the inside air temperature.

### PROBLEM 4.34

**KNOWN:** Chip dimensions, contact resistance and substrate material.

**FIND:** Maximum allowable chip power dissipation.

**SCHEMATIC:**

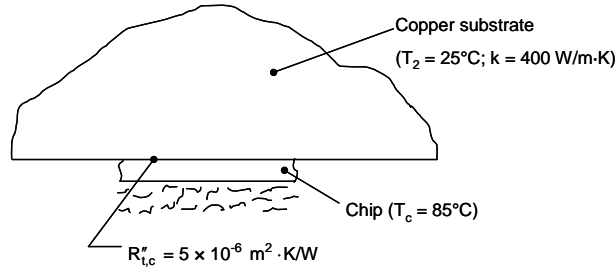

**ASSUMPTIONS:** (1) Steady-state conditions, (2) Constant properties, (3) Negligible heat transfer from back of chip, (4) Uniform chip temperature, (5) Infinitely large substrate, (6) Negligible heat loss from the exposed surface of the substrate.

**PROPERTIES:** Table A.1, copper ( $25^\circ\text{C}$ ):  $k = 400 \text{ W/m}\cdot\text{K}$ .

**ANALYSIS:** For the prescribed system, a thermal circuit may be drawn so that

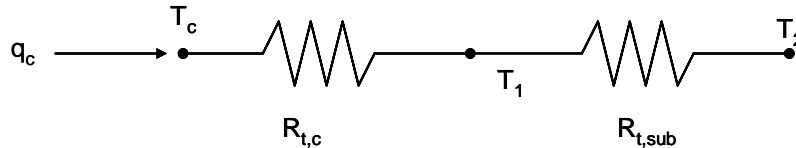

where  $T_1$  is the temperature of the substrate adjacent to the top of the chip. For an infinitely thin square object in an infinite medium we may apply Case 14 of Table 4.1 ( $q_{ss}^* = 0.932$ ) resulting in

$$q = q_{ss}^* k A_s (T_1 - T_2) / L_c$$

where  $L_c = (A_s / 4\pi)^{1/2}$ ;  $A_s = 2W_c^2$

Recognizing that the bottom surfaces of the chip and substrate are insulated, the heat loss to the substrate may be determined by combining the preceding equations and dividing by 2 (to account for no heat losses from the bottom of the chip) resulting in

$$q = (2\pi)^{1/2} q_{ss}^* W_c k (T_1 - T_2) = \frac{1}{R_{t,sub}} (T_1 - T_2)$$

or 
$$R_{t,sub} = \frac{1}{(2\pi)^{1/2} \times 0.932 \times 0.016 \text{ m} \times 400 \text{ W/m}\cdot\text{K}} = 0.067 \text{ K/W}$$

The thermal contact resistance is

Continued...

**PROBLEM 4.34 (Cont.)**

$$R_{t,c} = \frac{R''_{t,c}}{W_c^2} = \frac{5 \times 10^{-6} \text{ m}^2 \cdot \text{K/W}}{(0.016 \text{ m})^2} = 0.0195 \text{ K/W}$$

Therefore, the maximum allowable heat dissipation is

$$q_c = \frac{(85 - 25)^\circ\text{C}}{(0.0195 + 0.067) \text{ K/W}} = 694 \text{ W} \quad <$$

**COMMENTS:** (1) The copper block provides  $694/276 = 2.5$  times greater allowable heat dissipation relative to the heat sink of Problem 3.150. (2) Use of a large substrate would not be practical in many applications due to its size and weight. (3) The actual allowable heat dissipation is greater than calculated here because of additional heat losses from the bottom of the block and chip that are not accounted for in the solution.

### PROBLEM 4.35

**KNOWN:** Disc-shaped electronic devices dissipating 100 W mounted to aluminum alloy block with prescribed contact resistance.

**FIND:** (a) Temperature device will reach when block is at 27°C assuming all the power generated by the device is transferred by conduction to the block and (b) For the operating temperature found in part (a), the permissible operating power with a 30-pin fin heat sink.

**SCHEMATIC:**

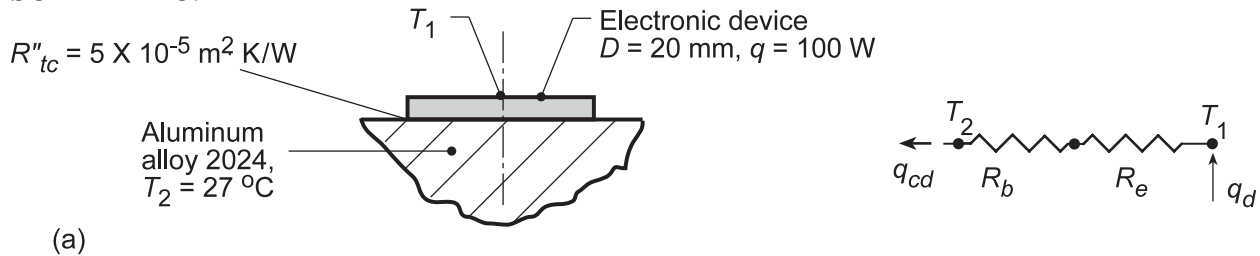

**ASSUMPTIONS:** (1) Two-dimensional, steady-state conduction, (2) Device is at uniform temperature,  $T_1$ , (3) Block behaves as semi-infinite medium.

**PROPERTIES:** Table A.1, Aluminum alloy 2024 (300 K):  $k = 177 \text{ W/m}\cdot\text{K}$ .

**ANALYSIS:** (a) The thermal circuit for the conduction heat flow between the device and the block shown in the schematic where  $R_e$  is the thermal contact resistance due to the epoxy-filled interface,

$$R_e = R''_{t,c} / A_c = R''_{t,c} / \left( \pi D^2 / 4 \right)$$

$$R_e = 5 \times 10^{-5} \text{ K}\cdot\text{m}^2/\text{W} / \left( \pi (0.020 \text{ m})^2 \right) / 4 = 0.159 \text{ K/W}$$

The thermal resistance between the device and the block is given in terms of the conduction shape factor, Table 4.1, as

$$R_b = 1/Sk = 1/(2Dk)$$

$$R_b = 1 / (2 \times 0.020 \text{ m} \times 177 \text{ W/m}\cdot\text{K}) = 0.141 \text{ K/W}$$

From the thermal circuit,

$$T_1 = T_2 + q_d (R_b + R_e)$$

$$T_1 = 27^\circ \text{C} + 100 \text{ W} (0.141 + 0.159) \text{ K/W}$$

$$T_1 = 27^\circ \text{C} + 30^\circ \text{C} = 57^\circ \text{C}$$

<

(b) The schematic below shows the device with the 30-pin fin heat sink with fins and base material of copper ( $k = 400 \text{ W/m}\cdot\text{K}$ ). The airstream temperature is 27°C and the convection coefficient is 1000  $\text{W/m}^2\cdot\text{K}$ .

Continued...

**PROBLEM 4.35 (Cont.)**

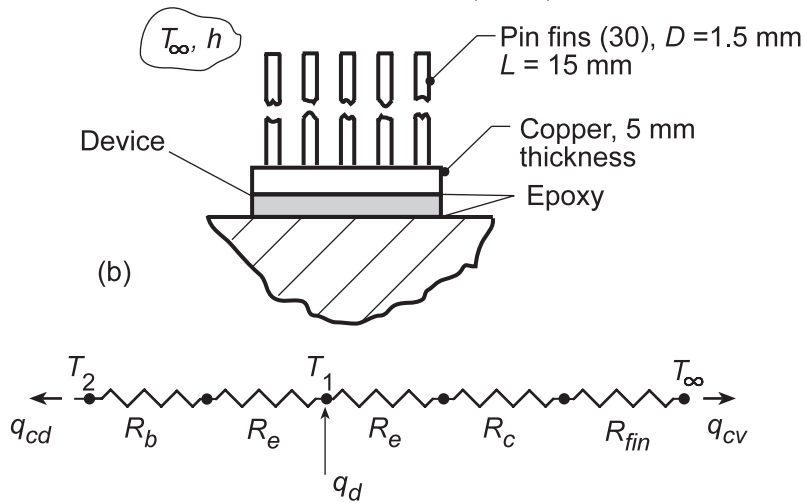

The thermal circuit for this system has two paths for the device power: to the block by conduction,  $q_{cd}$ , and to the ambient air by conduction to the fin array,  $q_{cv}$ ,

$$q_d = \frac{T_1 - T_2}{R_b + R_e} + \frac{T_1 - T_\infty}{R_e + R_c + R_{fin}} \quad (3)$$

where the thermal resistance of the fin base material is

$$R_c = \frac{L_c}{k_c A_c} = \frac{0.005 \text{ m}}{400 \text{ W/m} \cdot \text{K} \left( \pi (0.02)^2 / 4 \right) \text{ m}^2} = 0.03979 \text{ K/W} \quad (4)$$

and  $R_{fin}$  represents the thermal resistance of the fin array (see Section 3.6.5),

$$R_{fin} = R_{t,o} = \frac{1}{\eta_o h A_t} \quad (5, 3.108)$$

$$\eta_o = 1 - \frac{N A_f}{A_t} (1 - \eta_f) \quad (6, 3.107)$$

where the fin and prime surface area is

$$A_t = N A_f + A_b \quad (3.99)$$

$$A_t = N (\pi D_f L) + \left[ \pi D_d^2 / 4 - N \left( \pi D_f^2 / 4 \right) \right]$$

where  $A_f$  is the fin surface area,  $D_d$  is the device diameter and  $D_f$  is the fin diameter.

$$A_t = 30 (\pi \times 0.0015 \text{ m} \times 0.015 \text{ m}) + \left[ \pi (0.020 \text{ m})^2 / 4 - 30 \left( \pi (0.0015 \text{ m})^2 / 4 \right) \right]$$

$$A_t = 0.00212 \text{ m}^2 + 0.0002611 \text{ m}^2 = 0.00238 \text{ m}^2$$

Using the *IHT Model, Extended Surfaces, Performance Calculations, Rectangular Pin Fin*, find the fin efficiency as

$$\eta_f = 0.6769 \quad (7)$$

Continued...



**PROBLEM 4.35 (Cont.)**

Substituting numerical values into Equation (6), find

$$\eta_o = 1 - \frac{30 \times \pi \times 0.0015 \text{ m} \times 0.015 \text{ m}}{0.00238 \text{ m}^2} (1 - 0.6769)$$

$$\eta_o = 0.712$$

and the fin array thermal resistance is

$$R_{\text{fin}} = \frac{1}{0.712 \times 1000 \text{ W/m}^2 \cdot \text{K} \times 0.00238 \text{ m}^2} = 0.590 \text{ K/W}$$

Returning to Eq. (3), with  $T_1 = 57^\circ\text{C}$  from part (a), the permissible heat rate is

$$q_d = \frac{(57 - 27)^\circ\text{C}}{(0.141 + 0.159) \text{ K/W}} + \frac{(57 - 27)^\circ\text{C}}{(0.159 + 0.03979 + 0.590) \text{ K/W}}$$

$$q_d = 100 \text{ W} + 38 \text{ W} = 138 \text{ W}$$

<

**COMMENTS:** In calculating the fin efficiency,  $\eta_f$ , using the IHT Model it is not necessary to know the base temperature as  $\eta_f$  depends only upon geometric parameters, thermal conductivity and the convection coefficient.

### PROBLEM 4.36

**KNOWN:** Dimensions and thermal conductivities of a heater and a finned sleeve. Convection conditions on the sleeve surface.

**FIND:** (a) Heat rate per unit length, (b) Generation rate and centerline temperature of heater, (c) Effect of fin parameters on heat rate.

**SCHEMATIC:**

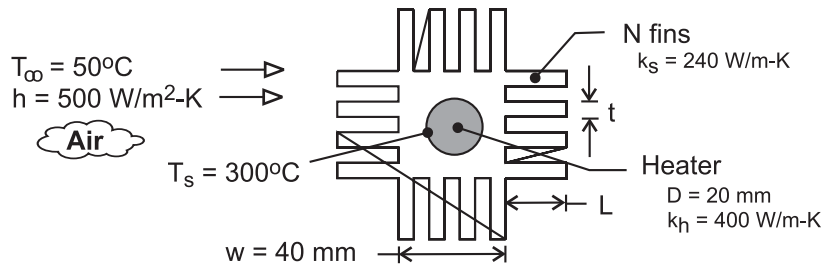

**ASSUMPTIONS:** (1) Steady state, (2) Constant properties, (3) Negligible contact resistance between heater and sleeve, (4) Uniform convection coefficient at outer surfaces of sleeve, (5) Uniform heat generation, (6) Negligible radiation.

**ANALYSIS:** (a) From the thermal circuit, the desired heat rate is

$$q' = \frac{T_s - T_\infty}{R'_{\text{cond}}(2D) + R'_{t,o}} = \frac{T_s - T_\infty}{R'_{\text{tot}}}$$

The two-dimensional conduction resistance, may be estimated from Eq. (4.21) and Case 6 of Table 4.2

$$R'_{\text{cond}}(2D) = \frac{1}{S'k_s} = \frac{\ln(1.08w/D)}{2\pi k_s} = \frac{\ln(2.16)}{2\pi(240 \text{ W/m}\cdot\text{K})} = 5.11 \times 10^{-4} \text{ m}\cdot\text{K/W}$$

The thermal resistance of the fin array is given by Equation (3.103), where  $\eta_o$  and  $A_t$  are given by Equations (3.107) and (3.104) and  $\eta_f$  is given by Equation (3.94). With  $L_c = L + t/2 = 0.022 \text{ m}$ ,  $m = (2h/k_s t)^{1/2} = 32.3 \text{ m}^{-1}$  and  $mL_c = 0.710$ ,

$$\eta_f = \frac{\tanh mL_c}{mL_c} = \frac{0.61}{0.71} = 0.86$$

$$A'_t = NA'_f + A'_b = N(2L + t) + (4w - Nt) = 0.704\text{m} + 0.096\text{m} = 0.800\text{m}$$

$$\eta_o = 1 - \frac{NA'_f}{A'_t} (1 - \eta_f) = 1 - \frac{0.704\text{m}}{0.800\text{m}} (0.14) = 0.88$$

$$R'_{t,o} = (\eta_o h A'_t)^{-1} = (0.88 \times 500 \text{ W/m}^2 \cdot \text{K} \times 0.80\text{m})^{-1} = 2.84 \times 10^{-3} \text{ m}\cdot\text{K/W}$$

$$q' = \frac{(300 - 50)^\circ\text{C}}{(5.11 \times 10^{-4} + 2.84 \times 10^{-3}) \text{ m}\cdot\text{K/W}} = 74,600 \text{ W/m} \quad <$$

Continued...

### PROBLEM 4.36 (Cont.)

(b) Equation (3.60) may be used to determine  $\dot{q}$ , if  $h$  is replaced by an overall coefficient based on the surface area of the heater. From Equation (3.37),

$$U_s A'_s = U_s \pi D = (R'_{\text{tot}})^{-1} = \left(3.35 \times 10^{-3} \text{ m} \cdot \text{K} / \text{W}\right)^{-1} = 298 \text{ W} / \text{m} \cdot \text{K}$$

$$U_s = 298 \text{ W} / \text{m} \cdot \text{K} / (\pi \times 0.02 \text{ m}) = 4750 \text{ W} / \text{m}^2 \cdot \text{K}$$

$$\dot{q} = 4 U_s (T_s - T_\infty) / D = 4 \left(4750 \text{ W} / \text{m}^2 \cdot \text{K}\right) (250^\circ\text{C}) / 0.02 \text{ m} = 2.38 \times 10^8 \text{ W} / \text{m}^3 <$$

From Equation (3.58) the centerline temperature is

$$T(0) = \frac{\dot{q} (D/2)^2}{4 k_h} + T_s = \frac{2.38 \times 10^8 \text{ W} / \text{m}^3 (0.01 \text{ m})^2}{4 (400 \text{ W} / \text{m} \cdot \text{K})} + 300^\circ\text{C} = 315^\circ\text{C} <$$

(c) Subject to the prescribed constraints, the following results have been obtained for parameter variations corresponding to  $16 \leq N \leq 40$ ,  $2 \leq t \leq 8 \text{ mm}$  and  $20 \leq L \leq 40 \text{ mm}$ .

<u>N</u>	<u>t(mm)</u>	<u>L(mm)</u>	<u><math>\eta_f</math></u>	<u><math>q'</math> (W/m)</u>
16	4	20	0.86	74,400
16	8	20	0.91	77,000
28	4	20	0.86	107,900
32	3	20	0.83	115,200
40	2	20	0.78	127,800
40	2	40	0.51	151,300

Clearly there is little benefit to simply increasing  $t$ , since there is no change in  $A'_t$  and only a marginal increase in  $\eta_f$ . However, due to an attendant increase in  $A'_t$ , there is significant benefit to increasing  $N$  for fixed  $t$  (no change in  $\eta_f$ ) and additional benefit in concurrently increasing  $N$  while decreasing  $t$ . In this case the effect of increasing  $A'_t$  exceeds that of decreasing  $\eta_f$ . The same is true for increasing  $L$ , although there is an upper limit at which diminishing returns would be reached. The upper limit to  $L$  could also be influenced by manufacturing constraints.

**COMMENTS:** Without the sleeve, the heat rate would be  $q' = \pi D h (T_s - T_\infty) = 7850 \text{ W} / \text{m}$ , which is well below that achieved by using the increased surface area afforded by the sleeve.

### PROBLEM 4.37

**KNOWN:** Dimensions of chip array. Conductivity of substrate. Convection conditions. Contact resistance. Expression for resistance of spreader plate. Maximum chip temperature.

**FIND:** Maximum chip heat rate.

**SCHEMATIC:**

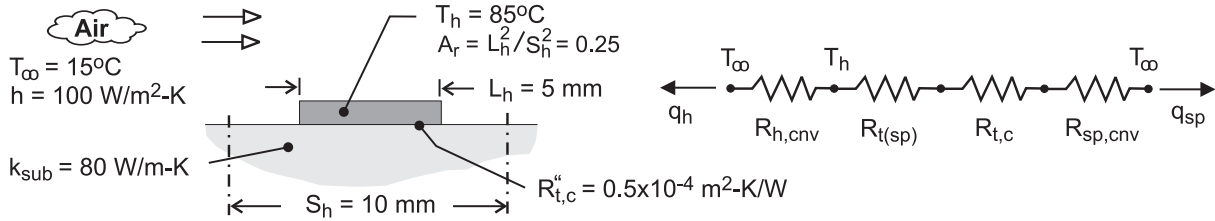

**ASSUMPTIONS:** (1) Steady-state, (2) Constant thermal conductivity, (3) Negligible radiation, (4) All heat transfer is by convection from the chip and the substrate surface (negligible heat transfer from bottom or sides of substrate).

**ANALYSIS:** From the thermal circuit,

$$q = q_h + q_{\text{sp}} = \frac{T_h - T_\infty}{R_{h,\text{cnv}}} + \frac{T_h - T_\infty}{R_{t(\text{sp})} + R_{t,c} + R_{\text{sp,cnv}}}$$

$$R_{h,\text{cnv}} = (h A_{s,h})^{-1} = (h L_h^2)^{-1} = \left[ 100 \text{ W/m}^2 \cdot \text{K} (0.005 \text{ m})^2 \right]^{-1} = 400 \text{ K/W}$$

$$R_{t(\text{sp})} = \frac{1 - 1.410 A_r + 0.344 A_r^3 + 0.043 A_r^5 + 0.034 A_r^7}{4 k_{\text{sub}} L_h} = \frac{1 - 0.353 + 0.005 + 0 + 0}{4 (80 \text{ W/m} \cdot \text{K}) (0.005 \text{ m})} = 0.408 \text{ K/W}$$

$$R_{t,c} = \frac{R''_{t,c}}{L_h^2} = \frac{0.5 \times 10^{-4} \text{ m}^2 \cdot \text{K/W}}{(0.005 \text{ m})^2} = 2.000 \text{ K/W}$$

$$R_{\text{sp,cnv}} = \left[ h (A_{\text{sub}} - A_{s,h}) \right]^{-1} = \left[ 100 \text{ W/m}^2 \cdot \text{K} \left( (0.010 \text{ m})^2 - (0.005 \text{ m})^2 \right) \right]^{-1} = 133.3 \text{ K/W}$$

$$q = \frac{70^\circ\text{C}}{400 \text{ K/W}} + \frac{70^\circ\text{C}}{(0.408 + 2 + 133.3) \text{ K/W}} = 0.18 \text{ W} + 0.52 \text{ W} = 0.70 \text{ W} \quad \leftarrow$$

**COMMENTS:** (1) The thermal resistances of the substrate and the chip/substrate interface are much less than the substrate convection resistance. Hence, the heat rate is increased almost in proportion to the additional surface area afforded by the substrate. An increase in the spacing between chips ( $S_h$ ) would increase  $q$  correspondingly.

(2) In the limit  $A_r \rightarrow 0$ ,  $R_{t(\text{sp})}$  reduces to  $2\pi^{1/2} k_{\text{sub}} D_h$  for a circular heat source and  $4k_{\text{sub}} L_h$  for a square source.

### PROBLEM 4.38

**KNOWN:** Internal corner of a two-dimensional system with prescribed convection boundary conditions.

**FIND:** Finite-difference equations for these situations: (a) Horizontal boundary is perfectly insulated and vertical boundary is subjected to a convection process ( $T_\infty, h$ ), (b) Both boundaries are perfectly insulated; compare result with Eq. 4.41.

**SCHEMATIC:**

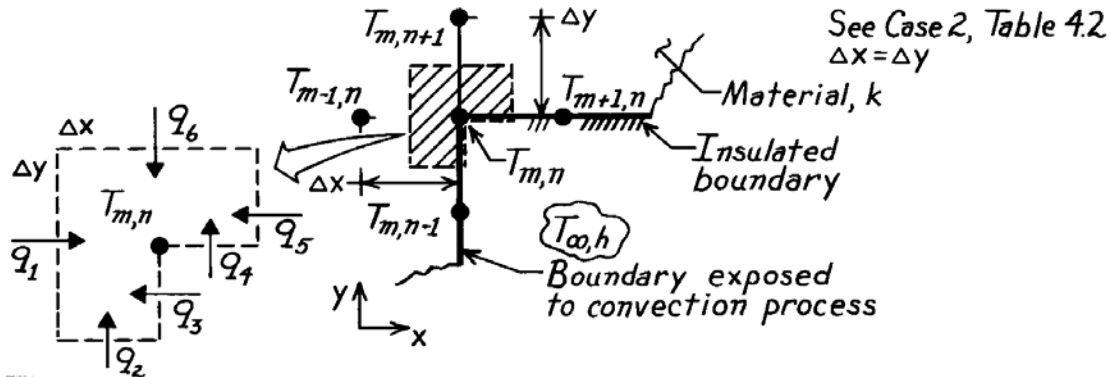

**ASSUMPTIONS:** (1) Steady-state conditions, (2) Two-dimensional conduction, (3) Constant properties, (4) No internal generation.

**ANALYSIS:** Consider the nodal network shown above and also as Case 2, Table 4.2. Having defined the control volume – the shaded area of unit thickness normal to the page – next identify the heat transfer processes. Finally, perform an energy balance wherein the processes are expressed using appropriate rate equations.

(a) With the horizontal boundary insulated and the vertical boundary subjected to a convection process, the energy balance results in the following finite-difference equation:

$$\begin{aligned} \dot{E}_{in} - \dot{E}_{out} = 0 \quad q_1 + q_2 + q_3 + q_4 + q_5 + q_6 = 0 \\ k(\Delta y \cdot 1) \frac{T_{m-1,n} - T_{m,n}}{\Delta x} + k \left[ \frac{\Delta x}{2} \cdot 1 \right] \frac{T_{m,n-1} - T_{m,n}}{\Delta y} + h \left[ \frac{\Delta y}{2} \cdot 1 \right] (T_\infty - T_{m,n}) \\ + 0 + k \left[ \frac{\Delta y}{2} \cdot 1 \right] \frac{T_{m+1,n} - T_{m,n}}{\Delta x} + k(\Delta x \cdot 1) \frac{T_{m,n+1} - T_{m,n}}{\Delta y} = 0. \end{aligned}$$

Letting  $\Delta x = \Delta y$ , and regrouping, find

$$2(T_{m-1,n} + T_{m,n+1}) + (T_{m+1,n} + T_{m,n-1}) + \frac{h\Delta x}{k} T_\infty - \left[ 6 + \frac{h\Delta x}{k} \right] T_{m,n} = 0. \quad <$$

(b) With both boundaries insulated, the energy balance would have  $q_3 = q_4 = 0$ . The same result would be obtained by letting  $h = 0$  in the previous result. Hence,

$$2(T_{m-1,n} + T_{m,n+1}) + (T_{m+1,n} + T_{m,n-1}) - 6 T_{m,n} = 0. \quad <$$

Note that this expression compares exactly with Equation 4.41 when  $h = 0$ , which corresponds to insulated boundaries.

### PROBLEM 4.39

**KNOWN:** Plane surface of two-dimensional system.

**FIND:** The finite-difference equation for nodal point on this boundary when (a) insulated; compare result with Eq. 4.42, and when (b) subjected to a constant heat flux.

**SCHEMATIC:**

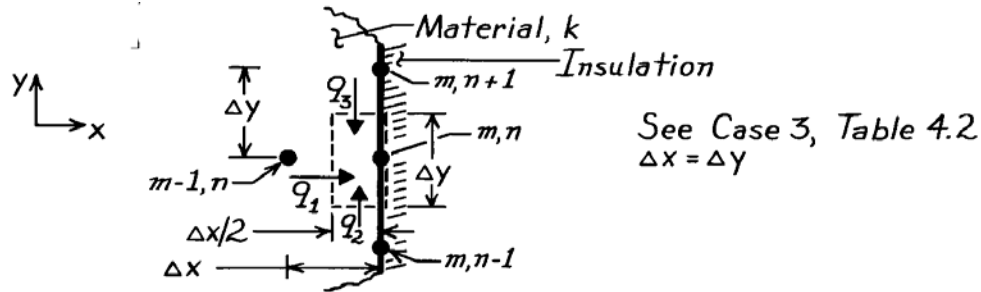

**ASSUMPTIONS:** (1) Two-dimensional, steady-state conduction with no generation, (2) Constant properties, (3) Boundary is adiabatic.

**ANALYSIS:** (a) Performing an energy balance on the control volume,  $(\Delta x/2) \cdot \Delta y$ , and using the conduction rate equation, it follows that

$$\dot{E}_{in} - \dot{E}_{out} = 0 \quad q_1 + q_2 + q_3 = 0 \quad (1,2)$$

$$k(\Delta y \cdot 1) \frac{T_{m-1,n} - T_{m,n}}{\Delta x} + k \left[ \frac{\Delta x}{2} \cdot 1 \right] \frac{T_{m,n-1} - T_{m,n}}{\Delta y} + k \left[ \frac{\Delta x}{2} \cdot 1 \right] \frac{T_{m,n+1} - T_{m,n}}{\Delta y} = 0. \quad (3)$$

Note that there is no heat rate across the control volume surface at the insulated boundary.

Recognizing that  $\Delta x = \Delta y$ , the above expression reduces to the form

$$2T_{m-1,n} + T_{m,n-1} + T_{m,n+1} - 4T_{m,n} = 0. \quad (4) <$$

The Eq. 4.42 of Table 4.2 considers the same configuration but with the boundary subjected to a convection process. That is,

$$\left( 2T_{m-1,n} + T_{m,n-1} + T_{m,n+1} \right) + \frac{2h\Delta x}{k} T_{\infty} - 2 \left[ \frac{h\Delta x}{k} + 2 \right] T_{m,n} = 0. \quad (5)$$

Note that, if the boundary is insulated,  $h = 0$  and Eq. 4.42 reduces to Eq. (4).

(b) If the surface is exposed to a constant heat flux,  $q_0''$ , the energy balance has the form

$q_1 + q_2 + q_3 + q_0'' \cdot \Delta y = 0$  and the finite difference equation becomes

$$2T_{m-1,n} + T_{m,n-1} + T_{m,n+1} - 4T_{m,n} = -\frac{2q_0''\Delta x}{k}. \quad <$$

**COMMENTS:** Equation (4) can be obtained by using the “interior node” finite-difference equation, Eq. 4.29, where the insulated boundary is treated as a symmetry plane as shown below.

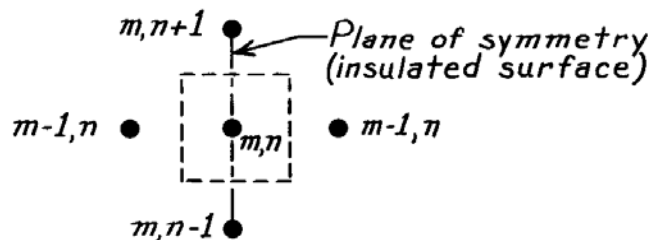

## PROBLEM 4.40

**KNOWN:** External corner of a two-dimensional system whose boundaries are subjected to prescribed conditions.

**FIND:** Finite-difference equations for these situations: (a) Upper boundary is perfectly insulated and side boundary is subjected to a convection process, (b) Both boundaries are perfectly insulated; compare result with Eq. 4.43.

**SCHEMATIC:**

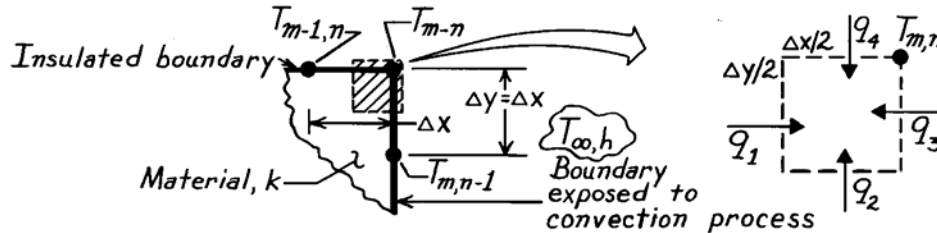

**ASSUMPTIONS:** (1) Steady-state conditions, (2) Two-dimensional conduction, (3) Constant properties, (4) No internal generation.

**ANALYSIS:** Consider the nodal point configuration shown in the schematic and also as Case 4, Table 4.2. The control volume about the node – shaded area above of unit thickness normal to the page – has dimensions,  $(\Delta x/2)(\Delta y/2) \cdot 1$ . The heat transfer processes at the surface of the CV are identified as  $q_1, q_2 \dots$ . Perform an energy balance wherein the processes are expressed using the appropriate rate equations.

(a) With the upper boundary insulated and the side boundary subjected to a convection process, the energy balance has the form

$$\dot{E}_{\text{in}} - \dot{E}_{\text{out}} = 0 \quad q_1 + q_2 + q_3 + q_4 = 0 \quad (1,2)$$

$$k \left[ \frac{\Delta y}{2} \cdot 1 \right] \frac{T_{m-1,n} - T_{m,n}}{\Delta x} + k \left[ \frac{\Delta x}{2} \cdot 1 \right] \frac{T_{m,n-1} - T_{m,n}}{\Delta y} + h \left[ \frac{\Delta y}{2} \cdot 1 \right] (T_{\infty} - T_{m,n}) + 0 = 0.$$

Letting  $\Delta x = \Delta y$ , and regrouping, find

$$T_{m,n-1} + T_{m-1,n} + \frac{h\Delta x}{k} T_{\infty} - 2 \left[ \frac{1}{2} \frac{h\Delta x}{k} + 1 \right] T_{m,n} = 0. \quad (3) <$$

(b) With both boundaries insulated, the energy balance of Eq. (2) would have  $q_3 = q_4 = 0$ . The same result would be obtained by letting  $h = 0$  in the finite-difference equation, Eq. (3). The result is

$$T_{m,n-1} + T_{m-1,n} - 2T_{m,n} = 0. \quad <$$

Note that this expression is identical to Eq. 4.43 when  $h = 0$ , in which case both boundaries are insulated.

**COMMENTS:** Note the convenience resulting from formulating the energy balance by *assuming* that all the heat flow is *into the node*.

### PROBLEM 4.41

**KNOWN:** Boundary conditions that change from specified heat flux to convection.

**FIND:** The finite difference equation for the node at the point where the boundary condition changes.

**SCHEMATIC:**

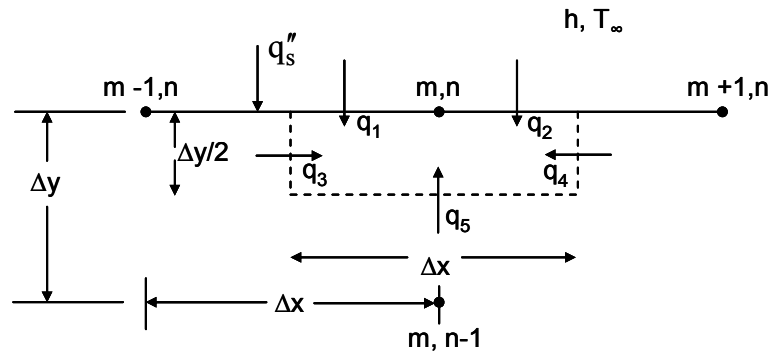

**ASSUMPTIONS:** (1) Two dimensional, steady-state conduction with no generation, (2) Constant properties.

**ANALYSIS:** Performing an energy balance on the control volume  $\Delta x \cdot \Delta y/2$ ,

$$\dot{E}_{in} - \dot{E}_{out} = 0 \quad q_1 + q_2 + q_3 + q_4 + q_5 = 0$$

Expressing  $q_1$  in terms of the specified heat flux,  $q_2$  in terms of the known heat transfer coefficient and environment temperature, and the remaining heat rates using the conduction rate equation,

$$q_1 = q_s'' \frac{\Delta x}{2} \cdot 1$$

$$q_2 = h(T_\infty - T_{m,n}) \frac{\Delta x}{2} \cdot 1$$

$$q_3 = \frac{k(T_{m-1,n} - T_{m,n}) \Delta y}{\Delta x} \cdot 1$$

$$q_4 = \frac{k(T_{m+1,n} - T_{m,n}) \Delta y}{\Delta x} \cdot 1$$

$$q_5 = \frac{k(T_{m,n-1} - T_{m,n})}{\Delta y} \Delta x \cdot 1$$

Letting  $\Delta x = \Delta y$ , substituting these expressions into the energy balance, and rearranging yields

$$T_{m-1,n} + T_{m+1,n} + 2T_{m,n-1} - \left[ 4 + \frac{h\Delta x}{k} \right] T_{m,n} + \frac{h\Delta x}{k} T_\infty + \frac{q_s'' \Delta x}{k} = 0$$

<



### PROBLEM 4.42

**KNOWN:** Control volume and nodal configuration in the vicinity of the interface between two materials.

**FIND:** Expressions for control surface heat rates. Finite difference equation at node  $m,n$ .

**SCHEMATIC:**

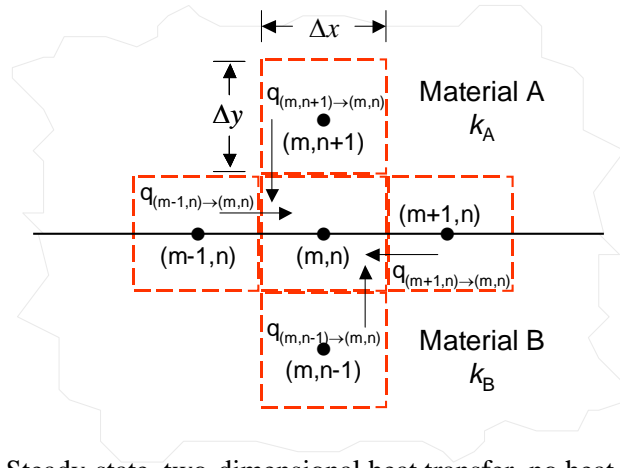

**ASSUMPTIONS:** Steady-state, two-dimensional heat transfer, no heat generation, negligible contact resistance.

**ANALYSIS:** Conduction from Node  $(m,n+1)$  to Node  $(m,n)$  occurs exclusively in Material A. Therefore,

$$q_{(m,n+1) \rightarrow (m,n)} = k_A L \frac{\Delta x}{\Delta y} [T_{m,n+1} - T_{m,n}] \quad <$$

Likewise for conduction from Node  $(m,n-1)$  to Node  $(m,n)$ ,

$$q_{(m,n-1) \rightarrow (m,n)} = k_B L \frac{\Delta x}{\Delta y} [T_{m,n-1} - T_{m,n}] \quad <$$

Conduction from Node  $(m-1,n)$  to Node  $(m,n)$  occurs in both Material A and Material B. In Material A,

$$q_{A(m-1,n) \rightarrow (m,n)} = k_A L \frac{\Delta y/2}{\Delta x} [T_{m-1,n} - T_{m,n}]$$

Likewise for conduction in Material B,

$$q_{B(m-1,n) \rightarrow (m,n)} = k_B L \frac{\Delta y/2}{\Delta x} [T_{m-1,n} - T_{m,n}]$$

For both materials,

$$\begin{aligned} q_{(m-1,n) \rightarrow (m,n)} &= q_{A(m-1,n) \rightarrow (m,n)} + q_{B(m-1,n) \rightarrow (m,n)} \\ &= k_A L \frac{\Delta y/2}{\Delta x} [T_{m-1,n} - T_{m,n}] + k_B L \frac{\Delta y/2}{\Delta x} [T_{m-1,n} - T_{m,n}] \\ &= (k_A + k_B) L \frac{\Delta y/2}{\Delta x} [T_{m-1,n} - T_{m,n}] \quad < \end{aligned}$$

Similarly for conduction from Node  $(m+1,n)$  to  $(m,n)$ ,

$$q_{(m+1,n) \rightarrow (m,n)} = (k_A + k_B) L \frac{\Delta y/2}{\Delta x} [T_{m+1,n} - T_{m,n}] \quad <$$

Continued...

### PROBLEM 4.42 (Cont.)

An energy balance on node m,n yields

$$q_{(m-1,n) \rightarrow (m,n)} + q_{(m+1,n) \rightarrow (m,n)} + q_{(m,n-1) \rightarrow (m,n)} + q_{(m,n+1) \rightarrow (m,n)} = 0$$

or

$$k_A \frac{\Delta x}{\Delta y} [T_{m,n+1} - T_{m,n}] + k_B \frac{\Delta x}{\Delta y} [T_{m,n-1} - T_{m,n}] + (k_A + k_B) \frac{\Delta y/2}{\Delta x} [T_{m-1,n} + T_{m+1,n} - 2T_{m,n}] = 0 \quad <$$

**COMMENTS:** How would you modify the analysis if the contact resistance is significant?

### PROBLEM 4.43

**KNOWN:** Conduction in a one-dimensional (radial) *cylindrical* coordinate system with volumetric generation.

**FIND:** Finite-difference equation for (a) Interior node,  $m$ , and (b) Surface node,  $n$ , with convection.

**SCHEMATIC:**

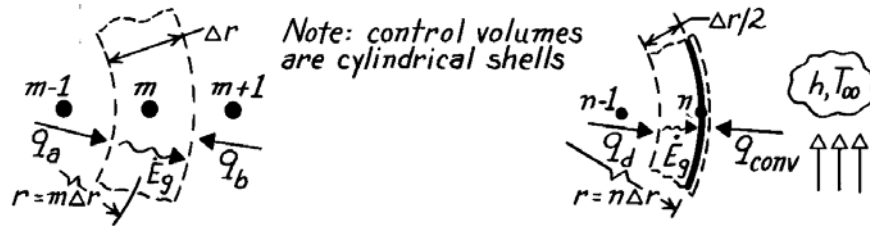

(a) Interior node,  $m$

(b) Surface node with convection,  $n$

**ASSUMPTIONS:** (1) Steady-state, one-dimensional (radial) conduction in *cylindrical* coordinates, (2) Constant properties.

**ANALYSIS:** (a) The network has nodes spaced at equal  $\Delta r$  increments with  $m = 0$  at the center; hence,  $r = m\Delta r$  (or  $n\Delta r$ ). The control volume is  $V = 2\pi r \cdot \Delta r \cdot \ell = 2\pi(m\Delta r)\Delta r \cdot \ell$ . The energy

balance is  $\dot{E}_{in} + \dot{E}_g = q_a + q_b + \dot{q}V = 0$

$$k \left[ 2\pi \left[ r - \frac{\Delta r}{2} \right] \ell \right] \frac{T_{m-1} - T_m}{\Delta r} + k \left[ 2\pi \left[ r + \frac{\Delta r}{2} \right] \ell \right] \frac{T_{m+1} - T_m}{\Delta r} + \dot{q} [2\pi(m\Delta r)\Delta r \ell] = 0.$$

Recognizing that  $r = m\Delta r$ , canceling like terms, and regrouping find

$$\left[ m - \frac{1}{2} \right] T_{m-1} + \left[ m + \frac{1}{2} \right] T_{m+1} - 2mT_m + \frac{\dot{q}m\Delta r^2}{k} = 0. \quad <$$

(b) The control volume for the surface node is  $V = 2\pi r \cdot (\Delta r/2) \cdot \ell$ . The energy balance is

$\dot{E}_{in} + \dot{E}_g = q_d + q_{conv} + \dot{q}V = 0$ . Use Fourier's law to express  $q_d$  and Newton's law of cooling for  $q_{conv}$  to obtain

$$k \left[ 2\pi \left[ r - \frac{\Delta r}{2} \right] \ell \right] \frac{T_{n-1} - T_n}{\Delta r} + h [2\pi r \ell] (T_\infty - T_n) + \dot{q} \left[ 2\pi(n\Delta r) \frac{\Delta r}{2} \ell \right] = 0.$$

Let  $r = n\Delta r$ , cancel like terms and regroup to find

$$\left[ n - \frac{1}{2} \right] T_{n-1} - \left[ \left[ n - \frac{1}{2} \right] + \frac{hn\Delta r}{k} \right] T_n + \frac{\dot{q}n\Delta r^2}{2k} + \frac{hn\Delta r}{k} T_\infty = 0. \quad <$$

**COMMENTS:** (1) Note that when  $m$  or  $n$  becomes very large compared to  $1/2$ , the finite-difference equation becomes independent of  $m$  or  $n$ . Then the cylindrical system approximates a rectangular one.

(2) The finite-difference equation for the center node ( $m = 0$ ) needs to be treated as a special case. The control volume is

$V = \pi(\Delta r/2)^2 \ell$  and the energy balance is

$$\dot{E}_{in} + \dot{E}_g = q_a + \dot{q}V = k \left[ 2\pi \left[ \frac{\Delta r}{2} \right] \ell \right] \frac{T_1 - T_0}{\Delta r} + \dot{q} \left[ \pi \left[ \frac{\Delta r}{2} \right]^2 \ell \right] = 0.$$

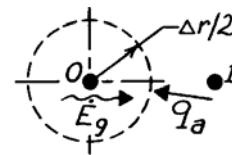

Regrouping, the finite-difference equation is  $-T_0 + T_1 + \frac{\dot{q}\Delta r^2}{4k} = 0$ .

## PROBLEM 4.44

**KNOWN:** Two-dimensional cylindrical configuration with prescribed radial ( $\Delta r$ ) and angular ( $\Delta\phi$ ) spacings of nodes.

**FIND:** Finite-difference equations for nodes 2, 3 and 1.

**SCHEMATIC:**

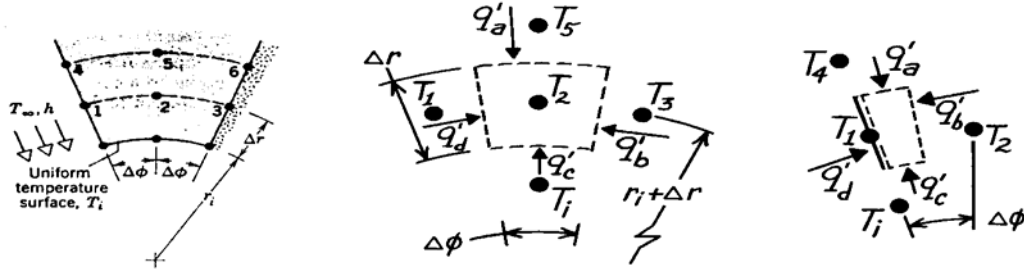

**ASSUMPTIONS:** (1) Steady-state conditions, (2) Two-dimensional conduction in cylindrical coordinates ( $r, \phi$ ), (3) Constant properties.

**ANALYSIS:** The method of solution is to define the appropriate control volume for each node, to identify relevant processes and then to perform an energy balance.

(a) Node 2. This is an *interior* node with control volume as shown above. The energy balance is  $\dot{E}_{in} = q'_a + q'_b + q'_c + q'_d = 0$ . Using Fourier's law for each process, find

$$k \left[ \left[ r_1 + \frac{3}{2} \Delta r \right] \Delta\phi \right] \frac{(T_5 - T_2)}{\Delta r} + k(\Delta r) \frac{(T_3 - T_2)}{(r_1 + \Delta r) \Delta\phi} + k \left[ \left[ r_1 + \frac{1}{2} \Delta r \right] \Delta\phi \right] \frac{(T_1 - T_2)}{\Delta r} + k(\Delta r) \frac{(T_1 - T_2)}{(r_1 + \Delta r) \Delta\phi} = 0.$$

Canceling terms and regrouping yields,

$$-2 \left[ (r_1 + \Delta r) + \frac{(\Delta r)^2}{(\Delta\phi)^2} \frac{1}{(r_1 + \Delta r)} \right] T_2 + \left[ r_1 + \frac{3}{2} \Delta r \right] T_5 + \frac{(\Delta r)^2}{(r_1 + \Delta r)(\Delta\phi)^2} (T_3 + T_1) + \left[ r_1 + \frac{1}{2} \Delta r \right] T_1 = 0.$$

(b) Node 3. The adiabatic surface behaves as a symmetry surface. We can utilize the result of Part (a) to write the finite-difference equation by inspection as

$$-2 \left[ (r_1 + \Delta r) + \frac{(\Delta r)^2}{(\Delta\phi)^2} \frac{1}{(r_1 + \Delta r)} \right] T_3 + \left[ r_1 + \frac{3}{2} \Delta r \right] T_6 + \frac{2(\Delta r)^2}{(r_1 + \Delta r)(\Delta\phi)^2} T_2 + \left[ r_1 + \frac{1}{2} \Delta r \right] T_1 = 0.$$

(c) Node 1. The energy balance is  $q'_a + q'_b + q'_c + q'_d = 0$ . Substituting,

$$k \left[ \left[ r_1 + \frac{3}{2} \Delta r \right] \frac{\Delta\phi}{2} \right] \frac{(T_4 - T_1)}{\Delta r} + k(\Delta r) \frac{(T_2 - T_1)}{(r_1 + \Delta r) \Delta\phi} + k \left[ \left[ r_1 + \frac{1}{2} \Delta r \right] \frac{\Delta\phi}{2} \right] \frac{(T_i - T_1)}{\Delta r} + h(\Delta r)(T_\infty - T_1) = 0$$

This expression could now be rearranged.

### PROBLEM 4.45

**KNOWN:** Heat generation and thermal boundary conditions of bus bar. Finite-difference grid.

**FIND:** Finite-difference equations for selected nodes.

**SCHEMATIC:**

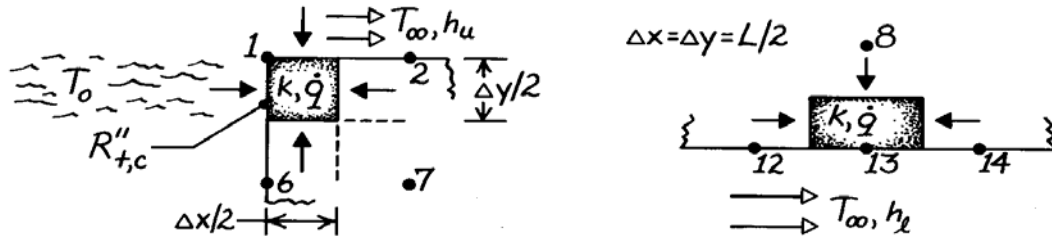

**ASSUMPTIONS:** (1) Steady-state conditions, (2) Two-dimensional conduction, (3) Constant properties.

**ANALYSIS:** (a) Performing an energy balance on the control volume,  $(\Delta x/2)(\Delta y/2) \cdot 1$ , find the FDE for node 1,

$$\begin{aligned} & \frac{T_0 - T_1}{R''_{t,c}/(\Delta y/2) \cdot 1} + h_u \left( \frac{\Delta x}{2} \cdot 1 \right) (T_\infty - T_1) + \frac{k(\Delta y/2 \cdot 1)}{\Delta x} (T_2 - T_1) \\ & + \frac{k(\Delta x/2 \cdot 1)}{\Delta y} (T_6 - T_1) + \dot{q} [(\Delta x/2)(\Delta y/2) \cdot 1] = 0 \\ & (\Delta x/kR''_{t,c})T_0 + (h_u \Delta x/k)T_\infty + T_2 + T_6 \\ & + \dot{q}(\Delta x)^2/2k - \left[ (\Delta x/kR''_{t,c}) + (h_u \Delta x/k) + 2 \right] T_1 = 0. \end{aligned} \quad <$$

(b) Performing an energy balance on the control volume,  $(\Delta x)(\Delta y/2) \cdot 1$ , find the FDE for node 13,

$$\begin{aligned} & h_l (\Delta x \cdot 1) (T_\infty - T_{13}) + (k/\Delta x) (\Delta y/2 \cdot 1) (T_{12} - T_{13}) \\ & + (k/\Delta y) (\Delta x \cdot 1) (T_8 - T_{13}) + (k/\Delta x) (\Delta y/2 \cdot 1) (T_{14} - T_{13}) + \dot{q} (\Delta x \cdot \Delta y/2 \cdot 1) = 0 \\ & (h_l \Delta x/k) T_\infty + 1/2 (T_{12} + 2T_8 + T_{14}) + \dot{q} (\Delta x)^2/2k - (h_l \Delta x/k + 2) T_{13} = 0. \end{aligned} \quad <$$

**COMMENTS:** For fixed  $T_0$  and  $T_\infty$ , the relative amounts of heat transfer to the air and heat sink are determined by the values of  $h$  and  $R''_{t,c}$ .

## PROBLEM 4.46

**KNOWN:** Nodal point configurations corresponding to a diagonal surface boundary subjected to a convection process and to the tip of a machine tool subjected to constant heat flux and convection cooling.

**FIND:** Finite-difference equations for the node  $m,n$  in the two situations shown.

**SCHEMATIC:**

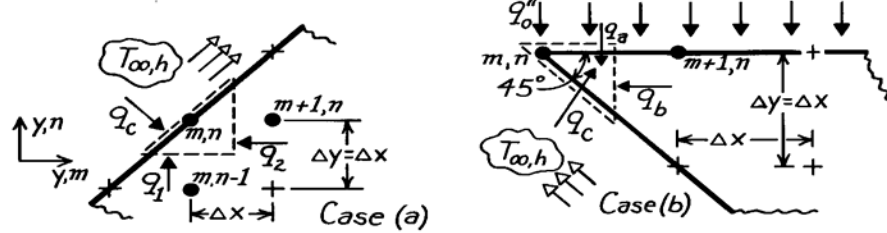

**ASSUMPTIONS:** (1) Steady-state, 2-D conduction, (2) Constant properties.

**ANALYSIS:** (a) The control volume about node  $m,n$  has triangular shape with sides  $\Delta x$  and  $\Delta y$  while the diagonal (surface) length is  $\sqrt{2} \Delta x$ . The heat rates associated with the control volume are due to conduction,  $q_1$  and  $q_2$ , and to convection,  $q_c$ . Performing an energy balance, find

$$\dot{E}_{in} - \dot{E}_{out} = 0 \quad q_1 + q_2 + q_c = 0$$

$$k(\Delta x \cdot 1) \frac{T_{m,n-1} - T_{m,n}}{\Delta y} + k(\Delta y \cdot 1) \frac{T_{m+1,n} - T_{m,n}}{\Delta x} + h(\sqrt{2} \Delta x \cdot 1)(T_{\infty} - T_{m,n}) = 0.$$

Note that we have considered the solid to have unit depth normal to the page. Recognizing that  $\Delta x = \Delta y$ , dividing each term by  $k$  and regrouping, find

$$T_{m,n-1} + T_{m+1,n} + \sqrt{2} \cdot \frac{h\Delta x}{k} T_{\infty} - \left[ 2 + \sqrt{2} \cdot \frac{h\Delta x}{k} \right] T_{m,n} = 0. \quad <$$

(b) The control volume about node  $m,n$  has triangular shape with sides  $\Delta x/2$  and  $\Delta y/2$  while the lower diagonal surface length is  $\sqrt{2}(\Delta x/2)$ . The heat rates associated with the control volume are due to the constant heat flux,  $q_a$ , to conduction,  $q_b$ , and to the convection process,  $q_c$ . Perform an energy balance,

$$\dot{E}_{in} - \dot{E}_{out} = 0 \quad q_a + q_b + q_c = 0$$

$$q_0'' \cdot \left[ \frac{\Delta x}{2} \cdot 1 \right] + k \cdot \left[ \frac{\Delta y}{2} \cdot 1 \right] \frac{T_{m+1,n} - T_{m,n}}{\Delta x} + h \cdot \left[ \sqrt{2} \cdot \frac{\Delta x}{2} \right] (T_{\infty} - T_{m,n}) = 0.$$

Recognizing that  $\Delta x = \Delta y$ , dividing each term by  $k/2$  and regrouping, find

$$T_{m+1,n} + \sqrt{2} \cdot \frac{h\Delta x}{k} \cdot T_{\infty} + q_0'' \cdot \frac{\Delta x}{k} - \left( 1 + \sqrt{2} \cdot \frac{h\Delta x}{k} \right) T_{m,n} = 0. \quad <$$

**COMMENTS:** Note the appearance of the term  $h\Delta x/k$  in both results, which is a dimensionless parameter (the *Biot number*) characterizing the relative effects of convection and conduction.

### PROBLEM 4.47

**KNOWN:** Nodal point on boundary between two materials.

**FIND:** Finite-difference equation for steady-state conditions.

**SCHEMATIC:**

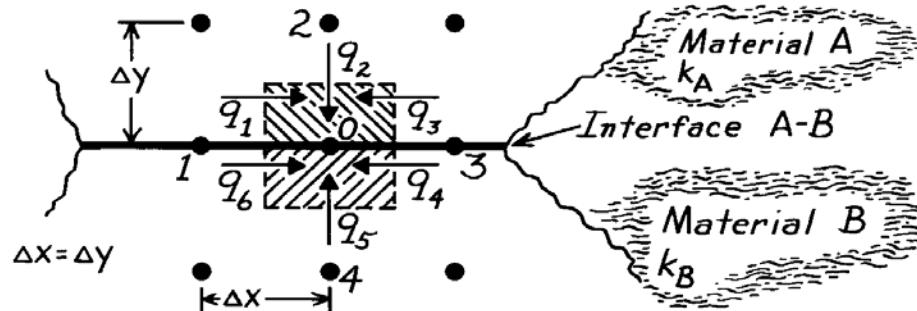

**ASSUMPTIONS:** (1) Steady-state conditions, (2) Two-dimensional conduction, (3) Constant properties, (4) No internal heat generation, (5) Negligible thermal contact resistance at interface.

**ANALYSIS:** The control volume is defined about nodal point 0 as shown above. The conservation of energy requirement has the form

$$\sum_{i=1}^6 q_i = q_1 + q_2 + q_3 + q_4 + q_5 + q_6 = 0$$

since all heat rates are shown as *into* the CV. Each heat rate can be written using Fourier's law,

$$k_A \cdot \frac{\Delta y}{2} \cdot \frac{T_1 - T_0}{\Delta x} + k_A \cdot \Delta x \cdot \frac{T_2 - T_0}{\Delta y} + k_A \cdot \frac{\Delta y}{2} \cdot \frac{T_3 - T_0}{\Delta x} + k_B \cdot \frac{\Delta y}{2} \cdot \frac{T_3 - T_0}{\Delta x} + k_B \cdot \Delta x \cdot \frac{T_4 - T_0}{\Delta y} + k_B \cdot \frac{\Delta y}{2} \cdot \frac{T_1 - T_0}{\Delta x} = 0.$$

Recognizing that  $\Delta x = \Delta y$  and regrouping gives the relation,

$$-T_0 + \frac{1}{4}T_1 + \frac{k_A}{2(k_A + k_B)}T_2 + \frac{1}{4}T_3 + \frac{k_B}{2(k_A + k_B)}T_4 = 0. \quad <$$

**COMMENTS:** Note that when  $k_A = k_B$ , the result agrees with Equation 4.29 which is appropriate for an interior node in a medium of fixed thermal conductivity.

### PROBLEM 4.48

**KNOWN:** Two-dimensional grid for a system with no internal volumetric generation.

**FIND:** Expression for heat rate per unit length normal to page crossing the isothermal boundary.

**SCHEMATIC:**

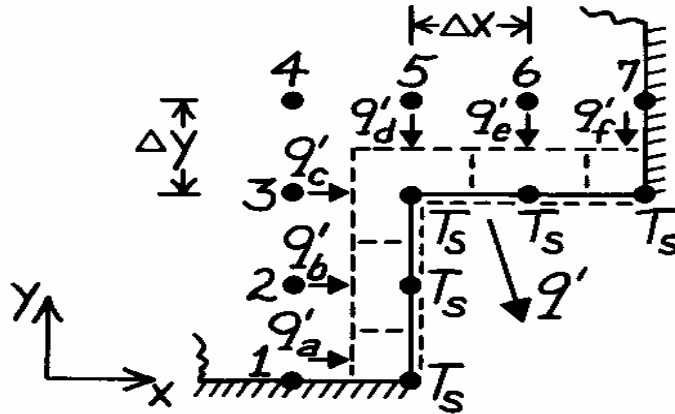

**ASSUMPTIONS:** (1) Steady-state conditions, (2) Two-dimensional heat transfer, (3) Constant properties.

**ANALYSIS:** Identify the surface nodes ( $T_s$ ) and draw control volumes about these nodes. Since there is no heat transfer in the direction parallel to the isothermal surfaces, the heat rate out of the constant temperature surface boundary is

$$q' = q'_a + q'_b + q'_c + q'_d + q'_e + q'_f$$

For each  $q'_i$ , use Fourier's law and pay particular attention to the manner in which the cross-sectional area and gradients are specified.

$$q' = k(\Delta y/2) \frac{T_1 - T_s}{\Delta x} + k(\Delta y) \frac{T_2 - T_s}{\Delta x} + k(\Delta y) \frac{T_3 - T_s}{\Delta x} + k(\Delta x) \frac{T_5 - T_s}{\Delta y} + k(\Delta x) \frac{T_6 - T_s}{\Delta y} + k(\Delta x/2) \frac{T_7 - T_s}{\Delta y}$$

Regrouping with  $\Delta x = \Delta y$ , find

$$q' = k[0.5T_1 + T_2 + T_3 + T_5 + T_6 + 0.5T_7 - 5T_s].$$

<

**COMMENTS:** Looking at the corner node, it is important to recognize the areas associated with  $q'_c$  and  $q'_d$  ( $\Delta y$  and  $\Delta x$ , respectively).



### PROBLEM 4.49

**KNOWN:** One-dimensional fin of uniform cross section insulated at one end with prescribed base temperature, convection process on surface, and thermal conductivity.

**FIND:** Finite-difference equation for these nodes: (a) Interior node,  $m$  and (b) Node at end of fin,  $n$ , where  $x = L$ .

**SCHEMATIC:**

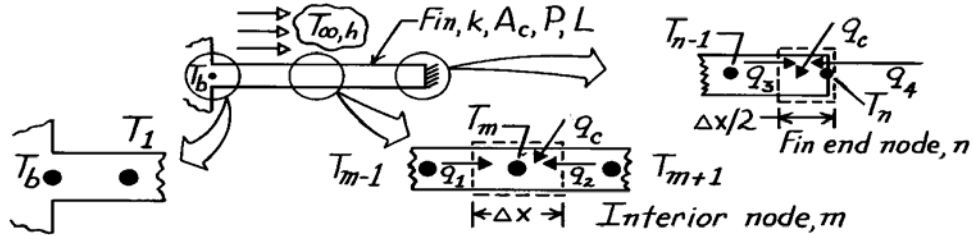

**ASSUMPTIONS:** (1) Steady-state conditions, (2) One-dimensional conduction.

**ANALYSIS:** (a) The control volume about node  $m$  is shown in the schematic; the node spacing and control volume length in the  $x$  direction are both  $\Delta x$ . The uniform cross-sectional area and fin perimeter are  $A_c$  and  $P$ , respectively. The heat transfer process on the control surfaces,  $q_1$  and  $q_2$ , represent conduction while  $q_c$  is the convection heat transfer rate between the fin and ambient fluid. Performing an energy balance, find

$$\begin{aligned} \dot{E}_{in} - \dot{E}_{out} &= 0 & q_1 + q_2 + q_c &= 0 \\ kA_c \frac{T_{m-1} - T_m}{\Delta x} + kA_c \frac{T_{m+1} - T_m}{\Delta x} + hP\Delta x (T_\infty - T_m) &= 0. \end{aligned}$$

Multiply the expression by  $\Delta x/kA_c$  and regroup to obtain

$$T_{m-1} + T_{m+1} + \frac{hP}{kA_c} \cdot \Delta x^2 T_\infty - \left[ 2 + \frac{hP}{kA_c} \Delta x^2 \right] T_m = 0 \quad 1 < m < n \quad <$$

Considering now the special node  $m = 1$ , then the  $m-1$  node is  $T_b$ , the base temperature. The finite-difference equation would be

$$T_b + T_2 + \frac{hP}{kA_c} \Delta x^2 T_\infty - \left[ 2 + \frac{hP}{kA_c} \Delta x^2 \right] T_1 = 0 \quad m=1 \quad <$$

(b) The control volume of length  $\Delta x/2$  about node  $n$  is shown in the schematic. Performing an energy balance,

$$\begin{aligned} \dot{E}_{in} - \dot{E}_{out} &= 0 & q_3 + q_4 + q_c &= 0 \\ kA_c \frac{T_{n-1} - T_n}{\Delta x} + 0 + hP \frac{\Delta x}{2} (T_\infty - T_n) &= 0. \end{aligned}$$

Note that  $q_4 = 0$  since the end ( $x = L$ ) is insulated. Multiplying by  $\Delta x/kA_c$  and regrouping,

$$T_{n-1} + \frac{hP}{kA_c} \cdot \frac{\Delta x^2}{2} T_\infty - \left[ \frac{hP}{kA_c} \cdot \frac{\Delta x^2}{2} + 1 \right] T_n = 0. \quad <$$

**COMMENTS:** The value of  $\Delta x$  will be determined by the selection of  $n$ ; that is,  $\Delta x = L/n$ . Note that the grouping,  $hP/kA_c$ , appears in the finite-difference and differential forms of the energy balance.

### PROBLEM 4.50

**KNOWN:** Two-dimensional network with prescribed nodal temperatures and thermal conductivity of the material.

**FIND:** Heat rate per unit length normal to page,  $q'$ .

**SCHEMATIC:**

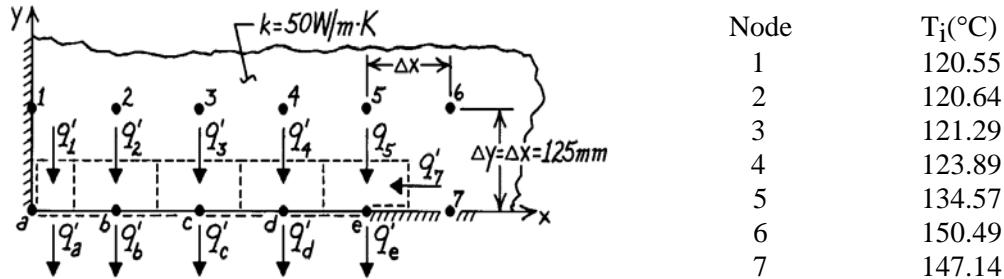

**ASSUMPTIONS:** (1) Steady-state conditions, (2) Two-dimensional heat transfer, (3) No internal volumetric generation, (4) Constant properties.

**ANALYSIS:** Construct control volumes around the nodes on the surface maintained at the uniform temperature  $T_s$  and indicate the heat rates. The heat rate per unit length is  $q' = q'_a + q'_b + q'_c + q'_d + q'_e$  or in terms of conduction terms between nodes,

$$q' = q'_1 + q'_2 + q'_3 + q'_4 + q'_5 + q'_7.$$

Each of these rates can be written in terms of nodal temperatures and control volume dimensions using Fourier's law,

$$q' = k \cdot \frac{\Delta x}{2} \cdot \frac{T_1 - T_s}{\Delta y} + k \cdot \Delta x \cdot \frac{T_2 - T_s}{\Delta y} + k \cdot \Delta x \cdot \frac{T_3 - T_s}{\Delta y} + k \cdot \Delta x \cdot \frac{T_4 - T_s}{\Delta y} + k \cdot \Delta x \cdot \frac{T_5 - T_s}{\Delta y} + k \cdot \frac{\Delta y}{2} \cdot \frac{T_7 - T_s}{\Delta x}.$$

and since  $\Delta x = \Delta y$ ,

$$q' = k[(1/2)(T_1 - T_s) + (T_2 - T_s) + (T_3 - T_s) + (T_4 - T_s) + (T_5 - T_s) + (1/2)(T_7 - T_s)].$$

Substituting numerical values, find

$$q' = 50 \text{ W/m} \cdot \text{K}[(1/2)(120.55 - 100) + (120.64 - 100) + (121.29 - 100) + (123.89 - 100) + (134.57 - 100) + (1/2)(147.14 - 100)]$$

$$q' = 6711 \text{ W/m.}$$

<

**COMMENTS:** For nodes a through d, there is no heat transfer into the control volumes in the x-direction. Look carefully at the energy balance for node e,  $q'_e = q'_5 + q'_7$ , and how  $q'_5$  and  $q'_7$  are evaluated.

### PROBLEM 4.51

**KNOWN:** Dimensions of mockup, absorbed irradiation in 100 mm × 100 mm area, thermal conductivity and emissivity of plywood and stainless steel, temperature of water, ambient air, and surroundings. Convection heat transfer coefficient.

**FIND:** (a) Maximum steady-state temperature for plywood at locations A and B, (c) Maximum steady-state temperature for stainless steel at locations A and B.

**SCHEMATIC:**

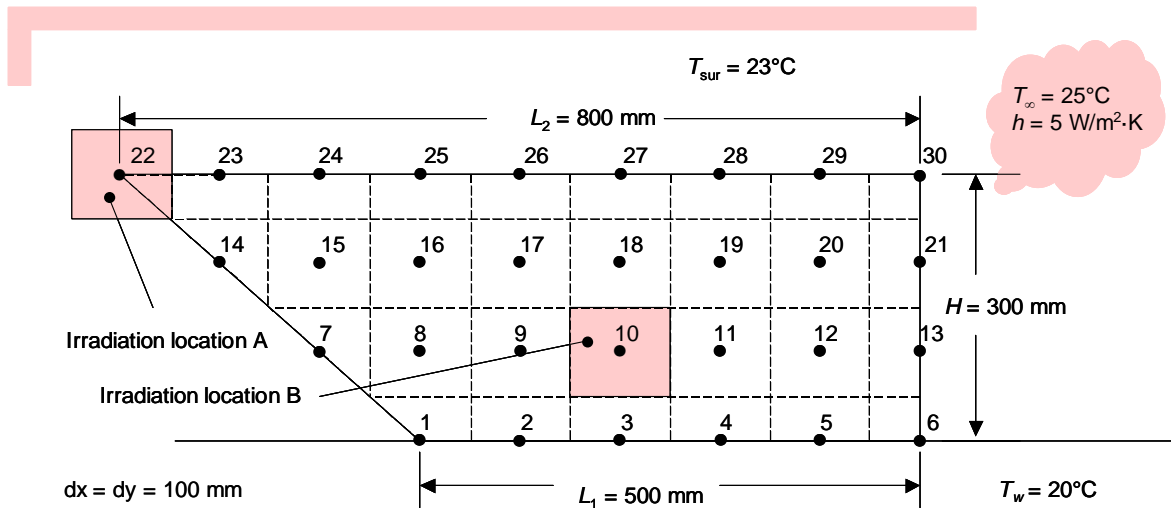

**ASSUMPTIONS:** (1) Steady-state conditions, (2) Constant properties, (3) Two-dimensional heat transfer, (4) Uniform irradiation, (5) Large surroundings, (6) Submerged section of mockup at water temperature, (7) Negligible temperature gradients through thickness of mockup.

**ANALYSIS:** We apply Newton's law of cooling, Fourier's law and Eq. 1.7 to a general control volume within the mockup and apply the following general finite-difference formula. Note that radiation and convective losses occur from both the front and back surfaces of the mockup through an area of  $2dx dy$ .

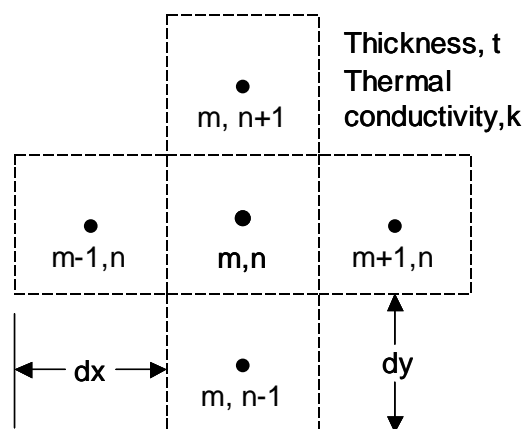

Continued...

### PROBLEM 4.51 (Cont.)

$$\frac{k(T_{m-1,n} - T_{m,n})}{dx}(tdy) + \frac{k(T_{m,n+1} - T_{m,n})}{dy}(tdx) + \frac{k(T_{m+1,n} - T_{m,n})}{dx}(tdy) + \frac{k(T_{m,n-1} - T_{m,n})}{dy}(tdx) + G_{s,N}(dx \cdot dy) + h(2dx \cdot dy)(T_{\infty} - T_{m,n}) + \varepsilon\sigma(2dx \cdot dy)(T_{sur}^4 - T_{m,n}^4) = 0$$

Likewise, for the control volume at the tip of the bow,

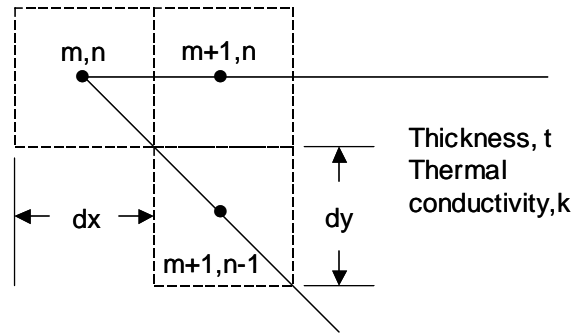

$$\frac{k(T_{m+1,n} - T_{m,n})}{dx}(tdy/2) + G_{s,N}(dx \cdot dy/8) + h(dx \cdot dy/4)(T_{\infty} - T_{m,n}) + \varepsilon\sigma(dx \cdot dy/4)(T_{sur}^4 - T_{m,n}^4) = 0$$

Additional finite difference energy balances are included in the IHT code available in Comment (1). The node numbers are keyed to the schematic.

(a) For plywood with  $k = 0.8$  W/m·K and  $\varepsilon = 0.9$ , the steady-state temperature at location A is  $T_{22} = 613.6^\circ\text{C}$ . For irradiation at location B, the steady-state temperature is  $T_{10} = 613.6^\circ\text{C}$ . Therefore, it does not matter where the irradiation is directed. The temperatures are very high and combustion is likely to occur. <

(b) For stainless steel with  $k = 15$  W/m·K and  $\varepsilon = 0.2$ , the steady-state temperature at location A is  $T_{22} = 804.7^\circ\text{C}$ . For irradiation at location B, the steady-state temperature is  $T_{10} = 767.3^\circ\text{C}$ . Therefore, it is preferable to direct the beam to the tip of the bow of the ship (location A). <

**COMMENTS:** (1) The IHT code is shown below. Note that this version of the code is associated with irradiation at location A for stainless steel. Appropriate modification of the thermal conductivity and emissivity, as well as revision of the energy balances at Nodes 22 and 10 are necessary to simulate the thermal response of stainless steel or irradiation at location B, respectively.

```

dx = 0.1           //m
dy = 0.1           //m
t = 10/1000        //m
k = 0.8            //W/mK
GsN = 700*100     //W/m^2
eps = 0.2
sigma = 5.67e-8    //Stefan-Boltzmann constant, W/m^2K^4
h = 5              //W/m^2K
Twater = 20 + 273 //K
Tinf = 25 + 273   //K
Tsur = 23 + 273   //K
    
```

Continued...

## PROBLEM 4.51 (Cont.)

//Nodes 1 through 6

T1 = Twater  
T2 = Twater  
T3 = Twater  
T4 = Twater  
T5 = Twater  
T6 = Twater

//Node 7

$$k^*t^*dx^*(T15 - T7)/dy + k^*t^*dy^*(T8 - T7)/dx + 2^*h^*(dx^*dy/2)^*(Tinf - T7) + 2^*eps^*sigma^*(dx^*dy/2)^*(Tsur^4 - T7^4) = 0$$

//Node 8

$$k^*t^*dy^*(T7 - T8)/dx + k^*t^*dx^*(T16 - T8)/dy + k^*t^*dy^*(T9 - T8)/dx + k^*t^*dx^*(T1 - T8)/dy + 2^*h^*(dx^*dy)^*(Tinf - T8) + 2^*eps^*sigma^*(dx^*dy)^*(Tsur^4 - T8^4) = 0$$

//Node 9

$$k^*t^*dy^*(T8 - T9)/dx + k^*t^*dx^*(T17 - T9)/dy + k^*t^*dy^*(T10 - T9)/dx + k^*t^*dx^*(T2 - T9)/dy + 2^*h^*(dx^*dy)^*(Tinf - T9) + 2^*eps^*sigma^*(dx^*dy)^*(Tsur^4 - T9^4) = 0$$

//Node 10

$$k^*t^*dy^*(T9 - T10)/dx + k^*t^*dx^*(T18 - T10)/dy + k^*t^*dy^*(T11 - T10)/dx + k^*t^*dx^*(T3 - T10)/dy + 2^*h^*(dx^*dy)^*(Tinf - T10) + 2^*eps^*sigma^*(dx^*dy)^*(Tsur^4 - T10^4) = 0$$

//Node 11

$$k^*t^*dy^*(T10 - T11)/dx + k^*t^*dx^*(T19 - T11)/dy + k^*t^*dy^*(T12 - T11)/dx + k^*t^*dx^*(T4 - T11)/dy + 2^*h^*(dx^*dy)^*(Tinf - T11) + 2^*eps^*sigma^*(dx^*dy)^*(Tsur^4 - T11^4) = 0$$

//Node 12

$$k^*t^*dy^*(T11 - T12)/dx + k^*t^*dx^*(T20 - T12)/dy + k^*t^*dy^*(T13 - T12)/dx + k^*t^*dx^*(T5 - T12)/dy + 2^*h^*(dx^*dy)^*(Tinf - T12) + 2^*eps^*sigma^*(dx^*dy)^*(Tsur^4 - T12^4) = 0$$

//Node 13

$$k^*t^*dy^*(T12 - T13)/dx + k^*t^*(dx/2)^*(T21 - T13)/dy + k^*t^*(dx/2)^*(T6 - T13)/dy + 2^*h^*(dx^*dy/2)^*(Tinf - T13) + 2^*eps^*sigma^*(dx^*dy/2)^*(Tsur^4 - T13^4) = 0$$

//Node 14

$$k^*t^*dy^*(T23 - T4)/dy + k^*t^*dy^*(T15 - T14)/dx + 2^*h^*(dx^*dy/2)^*(Tinf - T14) + 2^*eps^*sigma^*(dx^*dy/2)^*(Tsur^4 - T14^4) = 0$$

//Node 15

$$k^*t^*dy^*(T14 - T15)/dx + k^*t^*dx^*(T7 - T15)/dy + k^*t^*dy^*(T16 - T15)/dx + k^*t^*dx^*(T24 - T15)/dy + 2^*h^*(dx^*dy)^*(Tinf - T15) + 2^*eps^*sigma^*(dx^*dy)^*(Tsur^4 - T15^4) = 0$$

//Node 16

$$k^*t^*dy^*(T15 - T16)/dx + k^*t^*dx^*(T8 - T16)/dy + k^*t^*dy^*(T17 - T16)/dx + k^*t^*dx^*(T25 - T16)/dy + 2^*h^*(dx^*dy)^*(Tinf - T16) + 2^*eps^*sigma^*(dx^*dy)^*(Tsur^4 - T16^4) = 0$$

//Node 17

$$k^*t^*dy^*(T16 - T17)/dx + k^*t^*dx^*(T9 - T17)/dy + k^*t^*dy^*(T18 - T17)/dx + k^*t^*dx^*(T26 - T17)/dy + 2^*h^*(dx^*dy)^*(Tinf - T17) + 2^*eps^*sigma^*(dx^*dy)^*(Tsur^4 - T17^4) = 0$$

//Node 18

$$k^*t^*dy^*(T17 - T18)/dx + k^*t^*dx^*(T10 - T18)/dy + k^*t^*dy^*(T19 - T18)/dx + k^*t^*dx^*(T27 - T18)/dy + 2^*h^*(dx^*dy)^*(Tinf - T18) + 2^*eps^*sigma^*(dx^*dy)^*(Tsur^4 - T18^4) = 0$$

//Node 19

$$k^*t^*dy^*(T18 - T19)/dx + k^*t^*dx^*(T11 - T19)/dy + k^*t^*dy^*(T20 - T19)/dx + k^*t^*dx^*(T28 - T19)/dy + 2^*h^*(dx^*dy)^*(Tinf - T19) + 2^*eps^*sigma^*(dx^*dy)^*(Tsur^4 - T19^4) = 0$$

//Node 20

$$k^*t^*dy^*(T19 - T20)/dx + k^*t^*dx^*(T12 - T20)/dy + k^*t^*dy^*(T21 - T20)/dx + k^*t^*dx^*(T29 - T20)/dy + 2^*h^*(dx^*dy)^*(Tinf - T20) + 2^*eps^*sigma^*(dx^*dy)^*(Tsur^4 - T20^4) = 0$$

//Node 21

$$k^*t^*dy^*(T20 - T21)/dx + k^*t^*(dx/2)^*(T13 - T21)/dy + k^*t^*(dx/2)^*(T30 - T21)/dy + 2^*h^*(dx^*dy/2)^*(Tinf - T21) + 2^*eps^*sigma^*(dx^*dy/2)^*(Tsur^4 - T21^4) = 0$$

Continued...

## PROBLEM 4.51 (Cont.)

//Node 22

$$k^{**}(dy/2)*(T23 - T22)/dx + 2*(dx*dy/8)*h*(Tinf - T22) + 2*(dx*dy/8)*eps*sigma*(Tsur^4 - T22^4) + GsN*(dx*dy/8) = 0$$

//Node 23

$$k^{**}(dy/2)*(T22 - T23)/dx + k^{**}dx*(T14 - T23)/dy + k^{**}(dy/2)*(T24 - T23)/dx + 2*h*(dx*dy/2)*(Tinf - T23) + 2*eps*sigma*(dx*dy/2)*(Tsur^4 - T23^4) = 0$$

//Node 24

$$k^{**}(dy/2)*(T23 - T24)/dx + k^{**}dx*(T15 - T24)/dy + k^{**}(dy/2)*(T25 - T24)/dx + 2*h*(dx*dy/2)*(Tinf - T24) + 2*eps*sigma*(dx*dy/2)*(Tsur^4 - T24^4) = 0$$

//Node 25

$$k^{**}(dy/2)*(T24 - T25)/dx + k^{**}dx*(T16 - T25)/dy + k^{**}(dy/2)*(T26 - T25)/dx + 2*h*(dx*dy/2)*(Tinf - T25) + 2*eps*sigma*(dx*dy/2)*(Tsur^4 - T25^4) = 0$$

//Node 26

$$k^{**}(dy/2)*(T25 - T26)/dx + k^{**}dx*(T17 - T26)/dy + k^{**}(dy/2)*(T27 - T26)/dx + 2*h*(dx*dy/2)*(Tinf - T26) + 2*eps*sigma*(dx*dy/2)*(Tsur^4 - T26^4) = 0$$

//Node 27

$$k^{**}(dy/2)*(T26 - T27)/dx + k^{**}dx*(T18 - T27)/dy + k^{**}(dy/2)*(T28 - T27)/dx + 2*h*(dx*dy/2)*(Tinf - T27) + 2*eps*sigma*(dx*dy/2)*(Tsur^4 - T27^4) = 0$$

//Node 28

$$k^{**}(dy/2)*(T27 - T28)/dx + k^{**}dx*(T19 - T28)/dy + k^{**}(dy/2)*(T29 - T28)/dx + 2*h*(dx*dy/2)*(Tinf - T28) + 2*eps*sigma*(dx*dy/2)*(Tsur^4 - T28^4) = 0$$

//Node 29

$$k^{**}(dy/2)*(T28 - T29)/dx + k^{**}dx*(T20 - T29)/dy + k^{**}(dy/2)*(T30 - T29)/dx + 2*h*(dx*dy/2)*(Tinf - T29) + 2*eps*sigma*(dx*dy/2)*(Tsur^4 - T29^4) = 0$$

//Node 30

$$k^{**}(dy/2)*(T29 - T30)/dx + k^{**}(dx/2)*(T21 - T30)/dy + 2*h*(dx*dy/4)*(Tinf - T30) + 2*eps*sigma*(dx*dy/4)*(Tsur^4 - T30^4) = 0$$

(2) For irradiation at location A of plywood, steady-state temperatures in the vicinity of  $T_{22}$  are  $T_{23} = 42.99^\circ\text{C}$  and  $T_{14} = 25.62^\circ\text{C}$ . Temperatures at locations far-removed from the irradiation site are at  $T = 23.97^\circ\text{C}$ . For irradiation at location B, steady-state temperatures in the vicinity of  $T_{10}$  are  $T_{18} = 42.99^\circ\text{C}$  and  $T_9 = T_{11} = 42.80^\circ\text{C}$ . The thermal conductivity and thickness of the plywood are small, and conduction from the irradiated area to neighboring nodes is negligible. In fact, setting the thermal conductivity to  $k = 0 \text{ W/m}\cdot\text{K}$  yields a steady-state temperature of  $T_{22} = 619.8^\circ\text{C}$ , only a few degrees higher than when conduction is accounted for. (3) For irradiation at location A of stainless steel, steady-state temperatures in the vicinity of  $T_{22}$  are  $T_{23} = 274.9^\circ\text{C}$  and  $T_{14} = 237.2^\circ\text{C}$ . Temperatures at locations far-removed from the irradiation site are at  $T = 24.37^\circ\text{C}$ . For irradiation at location B, steady-state temperatures in the vicinity of  $T_{10}$  are  $T_{18} = 233.4^\circ\text{C}$ ,  $T_9 = 202.0^\circ\text{C}$  and  $T_{11} = 201.6^\circ\text{C}$ . The thermal conductivity and thickness of the stainless steel are sufficiently large so that conduction from the irradiated area to neighboring nodes is significant. Setting the thermal conductivity to  $k = 0 \text{ W/m}\cdot\text{K}$  yields a steady-state temperature of  $T_{22} = 1004^\circ\text{C}$ , significantly higher than when conduction is accounted for. (4) Although conduction losses from the irradiated areas are significant in the stainless steel, relatively high temperatures can be induced because radiation losses are reduced relative to plywood because of the lower emissivity. (5) Stainless steel will have a smaller absorptivity relative to plywood. Many more students would be needed to focus their individual mirrors to induce the absorbed irradiation value given in the problem statement. (6) The preceding analysis is based upon the assumption of two-dimensional heat transfer, implying the edge effects are negligible. However, for Node 22 (location A) the edge surface area is significant and constitutes approximately 30% of the entire exposed surface area. Including edge losses at location A will decrease the temperature of the wood mockup at that location to approximately  $T_{22} = 527^\circ\text{C}$  while inclusion of edge losses will not affect the predicted temperature at location B. For the stainless steel case,  $T_{22} = 700^\circ\text{C}$  and the temperature at location B is not affected. Hence, the recommended irradiation location is highly-dependent upon whether edge losses are accounted for.

### PROBLEM 4.52

**KNOWN:** Nodal temperatures from a steady-state, finite-difference analysis for a one-eighth symmetrical section of a square channel.

**FIND:** (a) Beginning with properly defined control volumes, derive the finite-difference equations for nodes 2, 4 and 7, and determine  $T_2$ ,  $T_4$  and  $T_7$ , and (b) Heat transfer loss per unit length from the channel,  $q'$ .

**SCHEMATIC:**

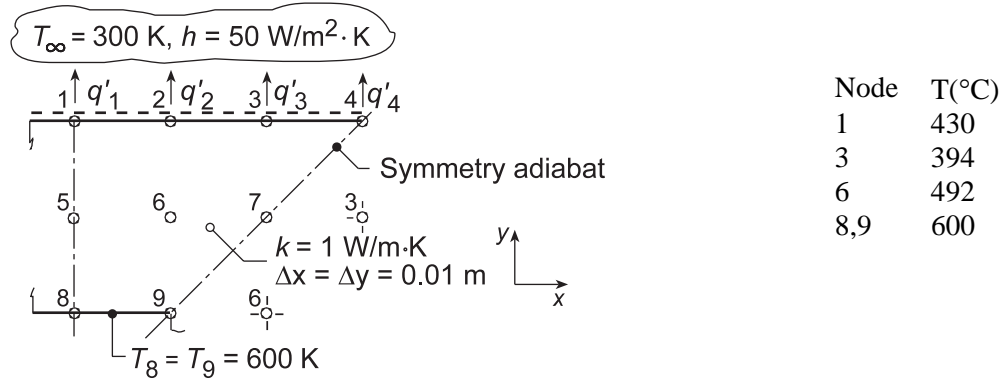

**ASSUMPTIONS:** (1) Steady-state conditions, (2) Two-dimensional conduction, (3) No internal volumetric generation, (4) Constant properties.

**ANALYSIS:** (a) Define control volumes about the nodes 2, 4, and 7, taking advantage of symmetry where appropriate and performing energy balances,  $\dot{E}_{in} - \dot{E}_{out} = 0$ , with  $\Delta x = \Delta y$ ,

Node 2:  $q'_a + q'_b + q'_c + q'_d = 0$

$$h\Delta x(T_\infty - T_2) + k(\Delta y/2)\frac{T_3 - T_2}{\Delta x} + k\Delta x\frac{T_6 - T_2}{\Delta y} + k(\Delta y/2)\frac{T_1 - T_2}{\Delta x} = 0$$

$$T_2 = \left[ 0.5T_1 + 0.5T_3 + T_6 + (h\Delta x/k)T_\infty \right] / \left[ 2 + (h\Delta x/k) \right]$$

$$T_2 = \left[ 0.5 \times 430 + 0.5 \times 394 + 492 + \left( 50 \text{ W/m}^2 \cdot \text{K} \times 0.01 \text{ m} / 1 \text{ W/m} \cdot \text{K} \right) 300 \right] \text{ K} / \left[ 2 + 0.50 \right]$$

$$T_2 = 422 \text{ K} \quad <$$

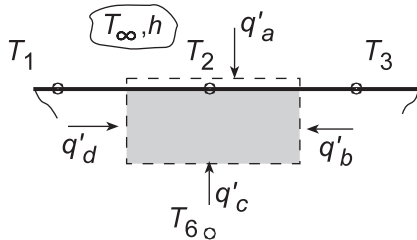

Node 4:  $q'_a + q'_b + q'_c = 0$

$$h(\Delta x/2)(T_\infty - T_4) + 0 + k(\Delta y/2)\frac{T_3 - T_4}{\Delta x} = 0$$

$$T_4 = \left[ T_3 + (h\Delta x/k)T_\infty \right] / \left[ 1 + (h\Delta x/k) \right]$$

$$T_4 = \left[ 394 + 0.5 \times 300 \right] \text{ K} / \left[ 1 + 0.5 \right] = 363 \text{ K} \quad <$$

Continued...

**PROBLEM 4.52 (Cont.)**

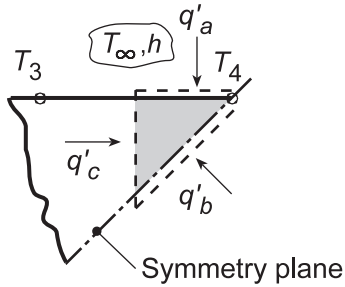

*Node 7:* From the first schematic, recognizing that the diagonal is a symmetry adiabat, we can treat node 7 as an interior node, hence

$$T_7 = 0.25(T_3 + T_3 + T_6 + T_6) = 0.25(394 + 394 + 492 + 492) \text{ K} = 443 \text{ K} \quad <$$

(b) The heat transfer loss from the upper surface can be expressed as the sum of the convection rates from each node as illustrated in the first schematic,

$$q'_{\text{cv}} = q'_1 + q'_2 + q'_3 + q'_4$$

$$q'_{\text{cv}} = h(\Delta x/2)(T_1 - T_\infty) + h\Delta x(T_2 - T_\infty) + h\Delta x(T_3 - T_\infty) + h(\Delta x/2)(T_4 - T_\infty)$$

$$q'_{\text{cv}} = 50 \text{ W/m}^2 \cdot \text{K} \times 0.01 \text{ m} \left[ (430 - 300)/2 + (422 - 300) + (394 - 300) + (363 - 300)/2 \right] \text{ K}$$

$$q'_{\text{cv}} = 156 \text{ W/m} \quad <$$

**COMMENTS:** (1) Always look for symmetry conditions which can greatly simplify the writing of the nodal equation as was the case for Node 7.

(2) Consider using the *IHT Tool, Finite-Difference Equations, for Steady-State, Two-Dimensional* heat transfer to determine the nodal temperatures  $T_1 - T_7$  when only the boundary conditions  $T_8$ ,  $T_9$  and  $(T_\infty, h)$  are specified.



### PROBLEM 4.53

**KNOWN:** Volumetric heat generation in a rectangular rod of uniform surface temperature.

**FIND:** (a) Temperature distribution in the rod, and (b) With boundary conditions unchanged, heat generation rate causing the midpoint temperature to reach 600 K.

**SCHEMATIC:**

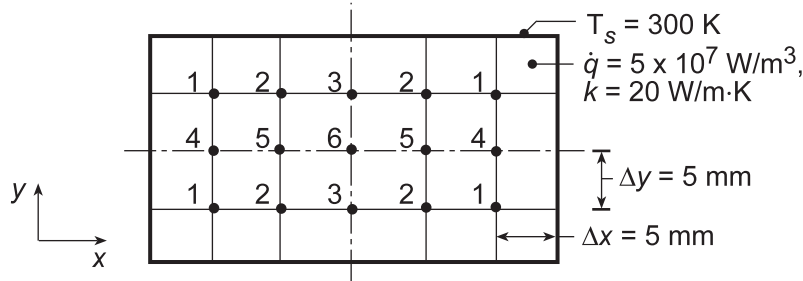

**ASSUMPTIONS:** (1) Steady-state, two-dimensional conduction, (2) Constant properties, (3) Uniform volumetric heat generation.

**ANALYSIS:** (a) From symmetry it follows that six unknown temperatures must be determined. Since all nodes are interior ones, the finite-difference equations may be obtained from Eq. 4.35 written in the form

$$T_i = 1/4 \sum T_{\text{neighbors}} + 1/4 (\dot{q}(\Delta x \Delta y)/k).$$

With  $\dot{q}(\Delta x \Delta y)/4k = 62.5$  K, the system of finite-difference equations is

$$T_1 = 0.25(T_s + T_2 + T_4 + T_s) + 15.625 \quad (1)$$

$$T_2 = 0.25(T_s + T_3 + T_5 + T_1) + 15.625 \quad (2)$$

$$T_3 = 0.25(T_s + T_2 + T_6 + T_2) + 15.625 \quad (3)$$

$$T_4 = 0.25(T_1 + T_5 + T_1 + T_s) + 15.625 \quad (4)$$

$$T_5 = 0.25(T_2 + T_6 + T_2 + T_4) + 15.625 \quad (5)$$

$$T_6 = 0.25(T_3 + T_5 + T_3 + T_5) + 15.625 \quad (6)$$

With  $T_s = 300$  K, the set of equations was written directly into the IHT workspace and solved for the nodal temperatures,

$T_1$	$T_2$	$T_3$	$T_4$	$T_5$	$T_6$ (K)
348.6	368.9	374.6	362.4	390.2	398.0

<

(b) With the boundary conditions unchanged, the  $\dot{q}$  required for  $T_6 = 600$  K can be found using the same set of equations in the IHT workspace, but with these changes: (1) replace the last term on the RHS (15.625) of Eqs. (1-6) by  $\dot{q}(\Delta x \Delta y)/4k = (0.005 \text{ m})^2 \dot{q}/4 \times 20 \text{ W/m} \cdot \text{K} = 3.125 \times 10^{-7} \dot{q}$  and (2) set  $T_6 = 600$  K. The set of equations has 6 unknown, five nodal temperatures plus  $\dot{q}$ . Solving find

$$\dot{q} = 1.53 \times 10^8 \text{ W/m}^3$$

<

### PROBLEM 4.54

**KNOWN:** Flue of square cross section with prescribed geometry, thermal conductivity and inner and outer surface temperatures.

**FIND:** Heat loss per unit length from the flue,  $q'$ .

**SCHEMATIC:**

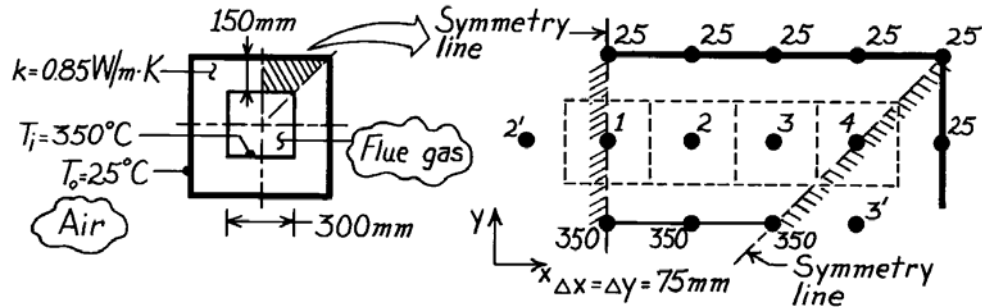

**ASSUMPTIONS:** (1) Steady-state, two-dimensional conduction, (2) Constant properties, (3) No internal generation.

**ANALYSIS:** Taking advantage of symmetry, the nodal network using the suggested 75mm grid spacing is shown above. To obtain the heat rate, we first need to determine the unknown temperatures  $T_1$ ,  $T_2$ ,  $T_3$  and  $T_4$ . Recognizing that these nodes may be treated as interior nodes, the nodal equations from Eq. 4.29 are

$$(T_2 + 25 + T_2 + 350) - 4T_1 = 0$$

$$(T_1 + 25 + T_3 + 350) - 4T_2 = 0$$

$$(T_2 + 25 + T_4 + 350) - 4T_3 = 0$$

$$(T_3 + 25 + 25 + T_3) - 4T_4 = 0.$$

Simultaneous solution yields  $T_1 = 183.9^\circ\text{C}$ ,  $T_2 = 180.3^\circ\text{C}$ ,  $T_3 = 162.2^\circ\text{C}$ ,  $T_4 = 93.6^\circ\text{C}$  <

From knowledge of the temperature distribution, the heat rate may be obtained by summing the heat rates across the nodal control volume surfaces, as shown in the sketch.

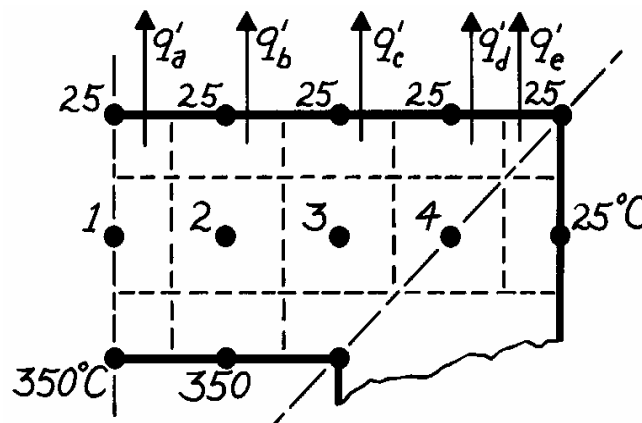

Continued...

### PROBLEM 4.54 (Cont.)

The heat rate leaving the outer surface of this flue section is,

$$\begin{aligned}
 q' &= q'_a + q'_b + q'_c + q'_d + q'_e \\
 q' &= k \frac{\Delta x}{\Delta y} \left[ \frac{1}{2}(T_1 - 25) + (T_2 - 25) + (T_3 - 25) + (T_4 - 25) + 0 \right] \\
 q' &= 0.85 \frac{\text{W}}{\text{m} \cdot \text{K}} \left[ \frac{1}{2}(183.9 - 25) + (180.3 - 25) + (162.2 - 26) + (93.6 - 25) \right] \\
 q' &= 374.5 \text{ W/m}.
 \end{aligned}$$

Since this flue section is 1/8 the total cross section, the total heat loss from the flue is

$$q' = 8 \times 374.5 \text{ W/m} = 3.00 \text{ kW/m.} \quad \leftarrow$$

**COMMENTS:** (1) The heat rate could have been calculated at the inner surface, and from the above sketch has the form

$$q' = k \frac{\Delta x}{\Delta y} \left[ \frac{1}{2}(350 - T_1) + (350 - T_2) + (350 - T_3) \right] = 374.5 \text{ W/m}.$$

This result should compare very closely with that found for the outer surface since the conservation of energy requirement must be satisfied in obtaining the nodal temperatures.

(2) The Gauss-Seidel iteration method can be used to find the nodal temperatures. Following the procedures of Appendix D,

$$\begin{aligned}
 T_1^k &= 0.50 T_2^{k-1} + 93.75 \\
 T_2^k &= 0.25 T_1^k + 0.25 T_3^{k-1} + 93.75 \\
 T_3^k &= 0.25 T_2^k + 0.25 T_4^{k-1} + 93.75 \\
 T_4^k &= 0.50 T_3^k + 12.5.
 \end{aligned}$$

The iteration procedure is implemented in the table on the following page, one row for each iteration  $k$ . The initial estimates, for  $k = 0$ , are all chosen as  $(350 + 25)/2 \approx 185^\circ\text{C}$ . Iteration is continued until the maximum temperature difference is less than  $0.2^\circ\text{C}$ , i.e.,  $\varepsilon < 0.2^\circ\text{C}$ .

Note that if the system of equations were organized in matrix form, Eq. 4.48, diagonal dominance would exist. Hence there is no need to reorder the equations since the magnitude of the diagonal element is greater than that of other elements in the same row.

k	$T_1(^{\circ}\text{C})$	$T_2(^{\circ}\text{C})$	$T_3(^{\circ}\text{C})$	$T_4(^{\circ}\text{C})$	
0	185	185	185	185	← initial estimate
1	186.3	186.6	186.6	105.8	
2	187.1	187.2	167.0	96.0	
3	187.4	182.3	163.3	94.2	
4	184.9	180.8	162.5	93.8	
5	184.2	180.4	162.3	93.7	
6	184.0	180.3	162.3	93.6	
7	183.9	180.3	162.2	93.6	← $\varepsilon < 0.2^\circ\text{C}$

The nodal temperatures are the same as those calculated using the simultaneous solution.

### PROBLEM 4.55

**KNOWN:** Steady-state temperatures (K) at three nodes of a long rectangular bar.

**FIND:** (a) Temperatures at remaining nodes and (b) heat transfer per unit length from the bar using nodal temperatures; compare with result calculated using knowledge of  $\dot{q}$ .

**SCHEMATIC:**

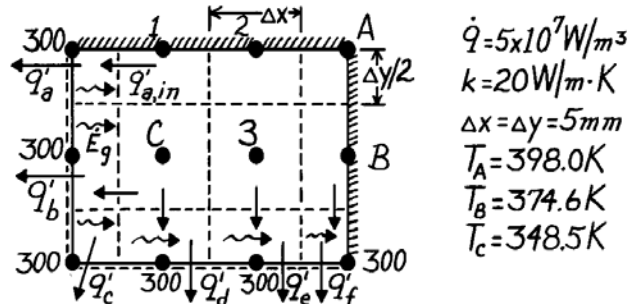

**ASSUMPTIONS:** (1) Steady-state, 2-D conduction, (2) Constant properties.

**ANALYSIS:** (a) The finite-difference equations for the nodes (1,2,3,A,B,C) can be written by inspection using Eq. 4.35 and recognizing that the adiabatic boundary can be represented by a symmetry plane.

$$\sum T_{\text{neighbors}} - 4T_i + \dot{q}\Delta x^2/k = 0 \quad \text{and} \quad \frac{\dot{q}\Delta x^2}{k} = \frac{5 \times 10^7 \text{ W/m}^3 (0.005\text{m})^2}{20 \text{ W/m} \cdot \text{K}} = 62.5\text{K}.$$

Node A (to find  $T_2$ ):

$$2T_2 + 2T_B - 4T_A + \dot{q}\Delta x^2/k = 0$$

$$T_2 = \frac{1}{2}(-2 \times 374.6 + 4 \times 398.0 - 62.5)\text{K} = 390.2\text{K} \quad <$$

Node 3 (to find  $T_3$ ):

$$T_C + T_2 + T_B + 300\text{K} - 4T_3 + \dot{q}\Delta x^2/k = 0$$

$$T_3 = \frac{1}{4}(348.5 + 390.2 + 374.6 + 300 + 62.5)\text{K} = 369.0\text{K} \quad <$$

Node 1 (to find  $T_1$ ):

$$300 + 2T_C + T_2 - 4T_1 + \dot{q}\Delta x^2/k = 0$$

$$T_1 = \frac{1}{4}(300 + 2 \times 348.5 + 390.2 + 62.5) = 362.4\text{K} \quad <$$

(b) The heat rate out of the bar is determined by calculating the heat rate out of each control volume around the 300 K nodes. Consider the node in the upper left-hand corner; from an energy balance

$$\dot{E}_{\text{in}} - \dot{E}_{\text{out}} + \dot{E}_g = 0 \quad \text{or} \quad q'_a = q'_{a,\text{in}} + \dot{E}_g \quad \text{where} \quad \dot{E}_g = \dot{q}V.$$

Hence, for the entire bar  $q'_{\text{bar}} = q'_a + q'_b + q'_c + q'_d + q'_e + q'_f$ , or

$$q'_{\text{bar}} = \left[ k \frac{\Delta y}{2} \frac{T_1 - 300}{\Delta x} + \dot{q} \left[ \frac{\Delta x}{2} \cdot \frac{\Delta y}{2} \right] \right]_a + \left[ k \Delta y \frac{T_C - 300}{\Delta x} + \dot{q} \left[ \frac{\Delta x}{2} \cdot \Delta y \right] \right]_b + \left[ \dot{q} \left[ \frac{\Delta x}{2} \cdot \frac{\Delta y}{2} \right] \right]_c + \left[ k \Delta x \frac{T_C - 300}{\Delta y} + \dot{q} \left[ \Delta x \cdot \frac{\Delta y}{2} \right] \right]_d + \left[ k \Delta x \frac{T_3 - 300}{\Delta y} + \dot{q} \left[ \Delta x \cdot \frac{\Delta y}{2} \right] \right]_e + \left[ k \frac{\Delta x}{2} \frac{T_B - 300}{\Delta y} + \dot{q} \left[ \frac{\Delta x}{2} \cdot \frac{\Delta y}{2} \right] \right]_f.$$

Substituting numerical values, find  $q'_{\text{bar}} = 7,502.5 \text{ W/m}$ . From an overall energy balance on the bar,

$$q'_{\text{bar}} = \dot{E}'_g = \dot{q}V/\ell = \dot{q}(3\Delta x \cdot 2\Delta y) = 5 \times 10^7 \text{ W/m}^3 \times 6(0.005\text{m})^2 = 7,500 \text{ W/m}. \quad <$$

As expected, the results of the two methods agree. Why must that be?

### PROBLEM 4.56

**KNOWN:** Dimensions and thermal conductivity distribution within a two-dimensional solid. Applied boundary conditions.

**FIND:** (a) Spatially-averaged thermal conductivity and heat rate per unit length based upon this value, (b) Heat rate per unit length for case 1 boundary conditions and comparison to estimated heat rate per unit length based upon the spatially-averaged thermal conductivity, (c) Heat rate per unit length for case 2 boundary conditions and comparison to estimated heat rate per unit length based upon the spatially-averaged thermal conductivity.

**ASSUMPTIONS:** Steady-state, one-dimensional heat transfer.

**ANALYSIS:** (a) The thermal conductivity varies only in the  $x$ -direction. Hence,

$$\begin{aligned}\bar{k} &= \frac{1}{L} \int_{x=0}^L k(x) dx = \frac{1}{L} \int_{x=0}^L (a + bx^{3/2}) dx = a + \frac{2}{5} bL^{3/2} < \\ &= 20 \frac{\text{W}}{\text{m} \cdot \text{K}} + \frac{2}{5} \times 7070 \frac{\text{W}}{\text{m}^{5/2} \cdot \text{K}} \times (0.02\text{m})^{3/2} = 28 \frac{\text{W}}{\text{m} \cdot \text{K}}\end{aligned}$$

Using this value, the heat rate per unit length is

$$q' = \bar{k}L(\Delta T)/L = 28 \frac{\text{W}}{\text{m} \cdot \text{K}} \times 50^\circ\text{C} = 1400\text{W/m} <$$

(b) The nodal network is shown below. Note that the heat transfer is one-dimensional.

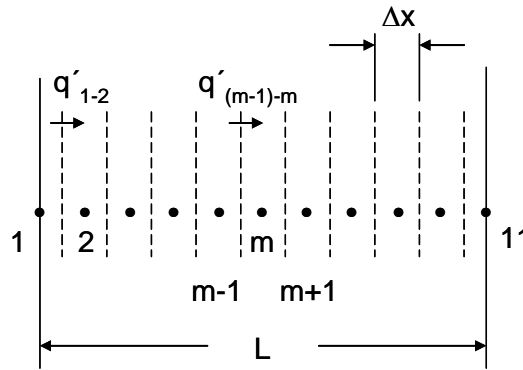

For any control surface, Eq. 4.46 may be combined with Fourier's law and written as

$$q'_{(m-1)-m} = \frac{T_{m-1} - T_m}{R'_{tot}} = \frac{T_{m-1} - T_m}{\left( \frac{\Delta x/2}{Lk_{m-1}} + \frac{\Delta x/2}{Lk_m} \right)} \quad (1)$$

where the thermal conductivities,  $k_{m-1}$  and  $k_m$  are evaluated at the left ( $m - 1$ ) and right ( $m$ ) nodes, respectively. At steady state, the heat rate per unit length is constant. Hence, we may write Eqn. (1) for each pair of nodal points from  $m = 1$  to  $m = 11$  using  $\Delta x = 2$  mm. The resulting heat rate per unit length is found by solving the 11 simultaneous equations for  $q'$  and the temperatures  $T_m$  for  $2 \leq m \leq 10$  yielding

$$q' = 1339 \text{ W/m} <$$

Continued...

### PROBLEM 4.56 (Cont.)

The predicted heat rate pure unit length is smaller than that of part (a).

(c) When the applied boundary conditions are changed to those of case 2, we may simply evaluate the heat transfer from the hot surface to the cool surface by evaluating the heat transfer in 11 different lanes and summing the results. For the interior lanes the width is  $\Delta x$  resulting in

$$q'_m = \frac{(\Delta T)k_m}{L} \Delta x \quad \text{for } 2 \leq m \leq 10$$

where  $\Delta T$  is the overall temperature difference across the domain. The thermal conductivities are evaluated at the locations of the nodes. For the lanes adjacent to the adiabatic boundaries,

$$q'_1 = k_1 \Delta T (\Delta x / 2) / L \quad \text{and} \quad q'_{11} = k_{11} \Delta T (\Delta x / 2) / L$$

and we evaluate the thermal conductivities  $k_1$  and  $k_{11}$  at the nodal points,  $x = 0$  and 20 mm, respectively. The heat rate per unit length of the object is

$$q' = \sum_{m=1}^{11} q'_m \quad \text{or} \quad q' = 1401 \text{ W/m} \quad <$$

The heat rate per unit length is nearly identical to that of part (a).

**COMMENTS:** (1) The agreement between the results of parts (a) and (c) is expected since

$$q' = \int_{x=0}^L q''(x) dx = \int_{x=0}^L (k(x) \Delta T / L) dx = \bar{k} (L/L) \Delta T .$$

The minor difference is due to the evaluation of

the thermal conductivity for each lane at the nodal point. The answers would become exactly the same as the spatial resolution of the numerical solution is increased. (2) In part (b) heat transfer is in the  $x$ -direction, the same direction in which thermal conductivity varies. This reduces heat transfer rates relative to the value calculated in parts (a) and (c). This is because the resistance expressed in Eq. (1) is composed of two values in series. The total resistance will be dominated by the higher of the two individual resistances. (3) Temperatures calculated for case 1 and heat rates in each lane for case 2 are shown in the table below.

Node or Lane	Temperature, °C (case 1)	Heat rate per unit length, W/m (case 2)
1	100.00	50
2	93.41	103.2
3	87.09	108.9
4	81.14	116.4
5	75.60	125.3
6	70.45	135.3
7	65.69	146.5
8	61.30	158.6
9	57.24	171.5
10	53.48	185.4
11	50.00	<u>99.99</u>
		1401

## PROBLEM 4.57

**KNOWN:** Steady-state temperatures at selected nodal points of the symmetrical section of a flow channel with uniform internal volumetric generation of heat. Inner and outer surfaces of channel experience convection.

**FIND:** (a) Temperatures at nodes 1, 4, 7, and 9, (b) Heat rate per unit length (W/m) from the outer surface A to the adjacent fluid, (c) Heat rate per unit length (W/m) from the inner fluid to surface B, and (d) Verify that results are consistent with an overall energy balance.

**SCHEMATIC:**

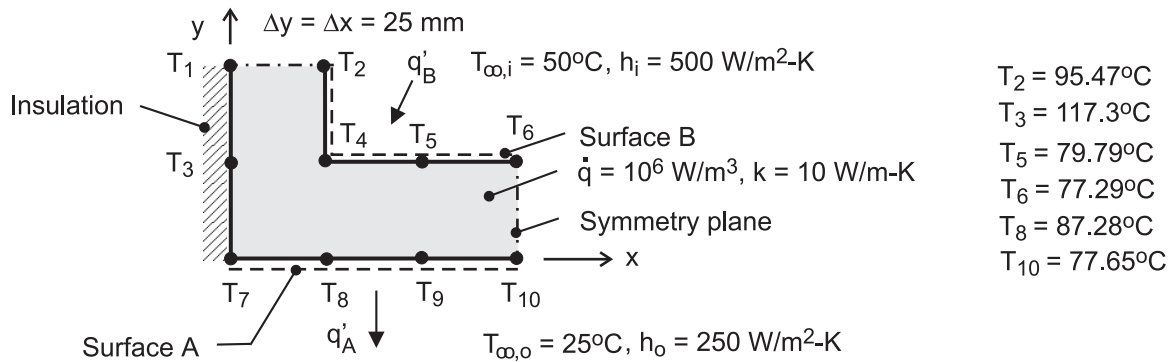

**ASSUMPTIONS:** (1) Steady-state, two-dimensional conduction, (2) Constant properties.

**ANALYSIS:** (a) The nodal finite-difference equations are obtained from energy balances on control volumes about the nodes shown in the schematics below.

*Node 1*

$$q'_a + q'_b + q'_c + q'_d + \dot{E}'_g = 0$$

$$0 + k(\Delta y/2) \frac{T_2 - T_1}{\Delta x} + k(\Delta x/2) \frac{T_3 - T_1}{\Delta y} + 0 + \dot{q}(\Delta x \cdot \Delta y/4) = 0$$

$$T_1 = (T_2 + T_3)/2 + \dot{q}\Delta x^2/4k$$

$$T_1 = (95.47 + 117.3)^\circ\text{C}/2 + 10^6 \text{ W/m}^3 (25 \times 25) \times 10^{-6} \text{ m}^2 / (4 \times 10 \text{ W/m} \cdot \text{K}) = 122.0^\circ\text{C}$$

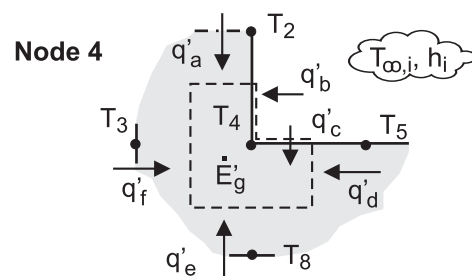
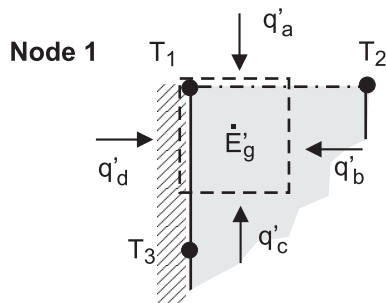

*Node 4*

$$q'_a + q'_b + q'_c + q'_d + q'_e + q'_f + \dot{E}'_g = 0$$

$$k(\Delta x/2) \frac{T_2 - T_4}{\Delta y} + h_i(\Delta y/2)(T_{\infty,i} - T_4) + h_i(\Delta x/2)(T_{\infty,i} - T_4) +$$

Continued ...

**PROBLEM 4.57 (Cont.)**

$$k(\Delta y/2) \frac{T_5 - T_4}{\Delta x} + k(\Delta x) \frac{T_8 - T_4}{\Delta y} + k(\Delta y) \frac{T_3 - T_4}{\Delta x} + \dot{q}(3\Delta x \cdot \Delta y/4) = 0$$

$$T_4 = \left[ T_2 + 2T_3 + T_5 + 2T_8 + 2(h_i \Delta x/k) T_{\infty,i} + (3\dot{q}\Delta x^2/2k) \right] / [6 + 2(h_i \Delta x/k)]$$

$$T_4 = 94.50^\circ\text{C}$$

Node 7

$$q'_a + q'_b + q'_c + q'_d + \dot{E}'_g = 0$$

$$k(\Delta x/2) \frac{T_3 - T_7}{\Delta y} + k(\Delta y/2) \frac{T_8 - T_7}{\Delta x} + h_o(\Delta x/2)(T_{\infty,o} - T_7) + 0 + \dot{q}(\Delta x \cdot \Delta y/4) = 0$$

$$T_7 = \left[ T_3 + T_8 + (h_o \Delta x/k) T_{\infty,o} + \dot{q}\Delta x^2/2k \right] / (2 + h_o \Delta x/k)$$

$$T_7 = 95.80^\circ\text{C}$$

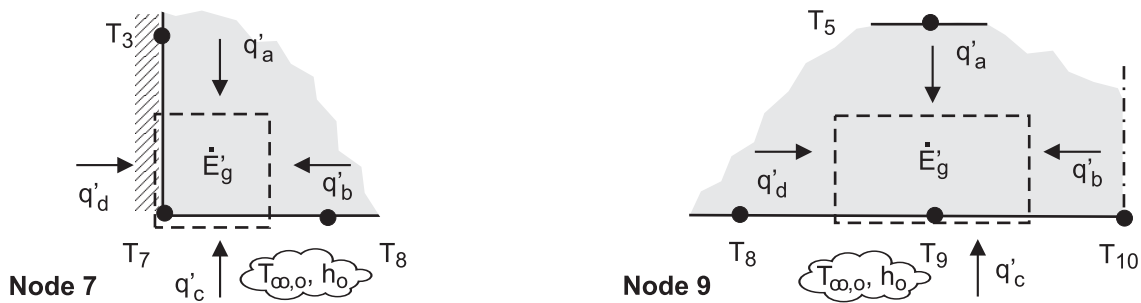

Node 9

$$q'_a + q'_b + q'_c + q'_d + \dot{E}'_g = 0$$

$$k(\Delta x) \frac{T_5 - T_9}{\Delta y} + k(\Delta y/2) \frac{T_{10} - T_9}{\Delta y} + h_o(\Delta x)(T_{\infty,o} - T_9) + k(\Delta y/2) \frac{T_8 - T_9}{\Delta x} + \dot{q}(\Delta x \cdot \Delta y/2) = 0$$

$$T_9 = \left[ T_5 + 0.5T_8 + 0.5T_{10} + (h_o \Delta x/k) T_{\infty,o} + \dot{q}\Delta x^2/2k \right] / (2 + h_o \Delta x/k)$$

$$T_9 = 79.67^\circ\text{C}$$

(b) The heat rate per unit length from the outer surface A to the adjacent fluid,  $q'_A$ , is the sum of the convection heat rates from the outer surfaces of nodes 7, 8, 9 and 10.

$$q'_A = h_o \left[ (\Delta x/2)(T_7 - T_{\infty,o}) + \Delta x(T_8 - T_{\infty,o}) + \Delta x(T_9 - T_{\infty,o}) + (\Delta x/2)(T_{10} - T_{\infty,o}) \right]$$

$$q'_A = 250 \text{ W/m}^2 \cdot \text{K} \left[ (25/2)(95.80 - 25) + 25(87.28 - 25) + 25(79.67 - 25) + (25/2)(77.65 - 25) \right] \times 10^{-3} \text{ m} \cdot \text{K}$$

Continued ...



### PROBLEM 4.57 (Cont.)

$$q'_A = 1117 \text{ W/m}$$

&lt;

(c) The heat rate per unit length from the inner fluid to the surface B,  $q'_B$ , is the sum of the convection heat rates from the inner surfaces of nodes 2, 4, 5 and 6.

$$q'_B = h_i \left[ (\Delta y / 2)(T_{\infty,i} - T_2) + (\Delta y / 2 + \Delta x / 2)(T_{\infty,i} - T_4) + \Delta x (T_{\infty,i} - T_5) + (\Delta x / 2)(T_{\infty,i} - T_6) \right]$$

$$q'_B = 500 \text{ W/m}^2 \cdot \text{K} \left[ (25/2)(50 - 95.47) + (25/2 + 25/2)(50 - 94.50) \right. \\ \left. + 25(50 - 79.79) + (25/2)(50 - 77.29) \right] \times 10^{-3} \text{ m} \cdot \text{K}$$

$$q'_B = -1383 \text{ W/m}$$

&lt;

(d) From an overall energy balance on the section, we see that our results are consistent since the conservation of energy requirement is satisfied.

$$\dot{E}'_{\text{in}} - \dot{E}'_{\text{out}} + \dot{E}'_{\text{gen}} = -q'_A + q'_B + \dot{E}'_{\text{gen}} = (-1117 - 1383 + 2500) \text{ W/m} = 0$$

where  $\dot{E}'_{\text{gen}} = \dot{q} \nabla' = 10^6 \text{ W/m}^3 [25 \times 50 + 25 \times 50] \times 10^{-6} \text{ m}^2 = 2500 \text{ W/m}$

**COMMENTS:** The nodal finite-difference equations for the four nodes can be obtained by using IHT Tool *Finite-Difference Equations | Two-Dimensional | Steady-state*. Options are provided to build the FDEs for interior, corner and surface nodal arrangements including convection and internal generation. The IHT code lines for the FDEs are shown below.

```
/* Node 1: interior node; e, w, n, s labeled 2, 2, 3, 3. */  
0.0 = fd_2d_int(T1,T2,T2,T3,T3,k,qdot,deltax,deltay)
```

```
/* Node 4: internal corner node, e-n orientation; e, w, n, s labeled 5, 3, 2, 8. */  
0.0 = fd_2d_ic_en(T4,T5,T3,T2,T8,k,qdot,deltax,deltay,Tinfo,hi,q"a4  
q"a4 = 0 // Applied heat flux, W/m^2; zero flux shown
```

```
/* Node 7: plane surface node, s-orientation; e, w, n labeled 8, 8, 3. */  
0.0 = fd_2d_psur_s(T7,T8,T8,T3,k,qdot,deltax,deltay,Tinfo,ho,q"a7  
q"a7=0 // Applied heat flux, W/m^2; zero flux shown
```

```
/* Node 9: plane surface node, s-orientation; e, w, n labeled 10, 8, 5. */  
0.0 = fd_2d_psur_s(T9, T10, T8, T5,k,qdot,deltax,deltay,Tinfo,ho,q"a9  
q"a9 = 0 // Applied heat flux, W/m^2; zero flux shown
```

### PROBLEM 4.58

**KNOWN:** Outer surface temperature, inner convection conditions, dimensions and thermal conductivity of a heat sink.

**FIND:** Nodal temperatures and heat rate per unit length.

**SCHEMATIC:**

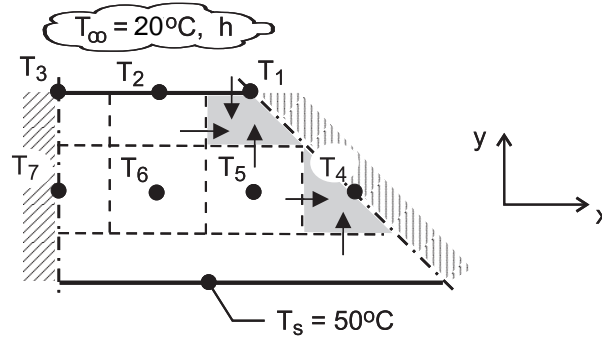

**ASSUMPTIONS:** (1) Steady-state, (2) Two-dimensional conduction, (3) Uniform outer surface temperature, (4) Constant thermal conductivity.

**ANALYSIS:** (a) To determine the heat rate, the nodal temperatures must first be computed from the corresponding finite-difference equations. From an energy balance for node 1,

$$h(\Delta x / 2 \cdot 1)(T_\infty - T_1) + k(\Delta y / 2 \cdot 1) \frac{T_2 - T_1}{\Delta x} + k(\Delta x \cdot 1) \frac{T_5 - T_1}{\Delta y} = 0$$

$$-\left(3 + \frac{h\Delta x}{k}\right)T_1 + T_2 + 2T_5 + \frac{h\Delta x}{k}T_\infty = 0 \quad (1)$$

With nodes 2 and 3 corresponding to Case 3 of Table 4.2,

$$T_1 - 2\left(\frac{h\Delta x}{k} + 2\right)T_2 + T_3 + 2T_6 + \frac{2h\Delta x}{k}T_\infty = 0 \quad (2)$$

$$T_2 - \left(\frac{h\Delta x}{k} + 2\right)T_3 + T_7 + \frac{h\Delta x}{k}T_\infty = 0 \quad (3)$$

where the symmetry condition is invoked for node 3. Applying an energy balance to node 4, we obtain

$$-2T_4 + T_5 + T_s = 0 \quad (4)$$

The interior nodes 5, 6 and 7 correspond to Case 1 of Table 4.2. Hence,

$$T_1 + T_4 - 4T_5 + T_6 + T_s = 0 \quad (5)$$

$$T_2 + T_5 - 4T_6 + T_7 + T_s = 0 \quad (6)$$

$$T_3 + 2T_6 - 4T_7 + T_s = 0 \quad (7)$$

where the symmetry condition is invoked for node 7. With  $T_s = 50^\circ\text{C}$ ,  $T_\infty = 20^\circ\text{C}$ , and

$h\Delta x / k = 5000 \text{ W/m}^2 \cdot \text{K}(0.005\text{m}) / 240 \text{ W/m} \cdot \text{K} = 0.1042$ , the solution to Eqs. (1) – (7) yields

$$T_1 = 46.61^\circ\text{C}, T_2 = 45.67^\circ\text{C}, T_3 = 45.44^\circ\text{C}, T_4 = 49.23^\circ\text{C}$$

$$T_5 = 48.46^\circ\text{C}, T_6 = 48.00^\circ\text{C}, T_7 = 47.86^\circ\text{C}$$

<

Continued ...

### PROBLEM 4.58 (Cont.)

The heat rate per unit length of channel may be evaluated by computing convection heat transfer from the inner surface. That is,

$$q' = 8h \left[ \Delta x / 2 (T_1 - T_\infty) + \Delta x (T_2 - T_\infty) + \Delta x / 2 (T_3 - T_\infty) \right]$$

$$q' = 8 \times 5000 \text{ W/m}^2 \cdot \text{K} \left[ 0.0025 \text{ m} (46.61 - 20)^\circ\text{C} + 0.005 \text{ m} (45.67 - 20)^\circ\text{C} \right.$$

$$\left. + 0.0025 \text{ m} (45.44 - 20)^\circ\text{C} \right] = 10,340 \text{ W/m} \quad <$$

(b) Since  $h = 5000 \text{ W/m}^2 \cdot \text{K}$  is at the high end of what can be achieved through forced convection, we consider the effect of reducing  $h$ . Representative results are as follows

$h \left( \text{W/m}^2 \cdot \text{K} \right)$	$T_1 \left( ^\circ\text{C} \right)$	$T_2 \left( ^\circ\text{C} \right)$	$T_3 \left( ^\circ\text{C} \right)$	$T_4 \left( ^\circ\text{C} \right)$	$T_5 \left( ^\circ\text{C} \right)$	$T_6 \left( ^\circ\text{C} \right)$	$T_7 \left( ^\circ\text{C} \right)$	$q' \left( \text{W/m} \right)$
200	49.84	49.80	49.79	49.96	49.93	49.91	49.90	477
1000	49.24	49.02	48.97	49.83	49.65	49.55	49.52	2325
2000	48.53	48.11	48.00	49.66	49.33	49.13	49.06	4510
5000	46.61	45.67	45.44	49.23	48.46	48.00	47.86	10,340

There are two resistances to heat transfer between the outer surface of the heat sink and the fluid, that due to conduction in the heat sink,  $R_{\text{cond}(2D)}$ , and that due to convection from its inner surface to the fluid,  $R_{\text{conv}}$ . With decreasing  $h$ , the corresponding increase in  $R_{\text{conv}}$  reduces heat flow and increases the uniformity of the temperature field in the heat sink. The nearly 5-fold reduction in  $q'$

corresponding to the 5-fold reduction in  $h$  from 1000 to 200  $\text{W/m}^2 \cdot \text{K}$  indicates that the convection resistance is dominant ( $R_{\text{conv}} \gg R_{\text{cond}(2D)}$ ).

**COMMENTS:** To check our finite-difference solution, we could assess its consistency with conservation of energy requirements. For example, an energy balance performed at the inner surface requires a balance between convection from the surface and conduction to the surface, which may be expressed as

$$q' = k(\Delta x \cdot 1) \frac{(T_5 - T_1)}{\Delta y} + k(\Delta x \cdot 1) \frac{T_6 - T_2}{\Delta y} + k(\Delta x / 2 \cdot 1) \frac{T_7 - T_3}{\Delta y}$$

Substituting the temperatures corresponding to  $h = 5000 \text{ W/m}^2 \cdot \text{K}$ , the expression yields  $q' = 10,340 \text{ W/m}$ , and, as it must be, conservation of energy is precisely satisfied. Results of the analysis may also be checked by using the expression  $q' = (T_s - T_\infty) / (R'_{\text{cond}(2D)} + R'_{\text{conv}})$ , where, for  $h = 5000 \text{ W/m}^2 \cdot \text{K}$ ,  $R'_{\text{conv}} = (1/4hw) = 2.5 \times 10^{-3} \text{ m} \cdot \text{K/W}$ , and from Eq. (4.27) and Case 11 of Table 4.1,  $R'_{\text{cond}} = [0.930 \ln(W/w) - 0.05] / 2\pi k = 3.94 \times 10^{-4} \text{ m} \cdot \text{K/W}$ . Hence,  $q' = (50 - 20)^\circ\text{C} / (2.5 \times 10^{-3} + 3.94 \times 10^{-4}) \text{ m} \cdot \text{K/W} = 10,370 \text{ W/m}$ , and the agreement with the finite-difference solution is excellent. Note that, even for  $h = 5000 \text{ W/m}^2 \cdot \text{K}$ ,  $R'_{\text{conv}} \gg R'_{\text{cond}(2D)}$ .

### PROBLEM 4.59

**KNOWN:** Dimensions of a two-dimensional object with isothermal and adiabatic boundaries.

**FIND:** Conduction heat transfer rate per unit depth from the hot surface to the cold surface.

**SCHEMATIC:**

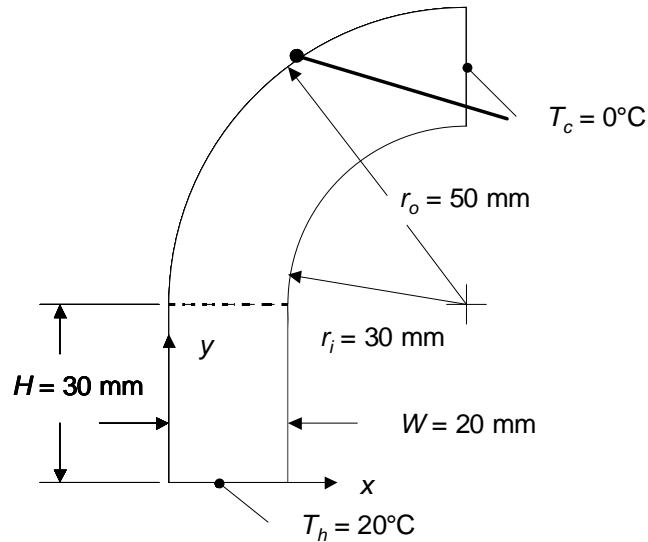

**ASSUMPTIONS:** (1) Steady-state conditions, (2) Constant properties, (3) No internal generation, (4) Two-dimensional conduction.

**ANALYSIS:** We may combine heat fluxes determined from Fourier's law with expressions for the size of the control surfaces of the various control volumes to determine the heat rate per unit depth into each control volume in the discretized domain, which is shown on the next page. Application of conservation of energy for each control volume yields the expression  $\dot{E}_{in} = 0$ . Note that energy balances for nodes 10, 11, and 12 are included in both the rectangular and cylindrical sub-domains. These energy balances couple the solutions together.

Rectangular Sub-Domain. For the rectangular sub-domain, application of Fourier's law in Cartesian coordinates along with conservation of energy yields the following finite difference equations.

Nodes 1, 2 and 3:  $T_1 = T_2 = T_3 = T_h = 20^\circ\text{C}$ .

$$\text{Node 4: } k \frac{(T_1 - T_4) \Delta x}{\Delta y} \frac{\Delta x}{2} + k \frac{(T_5 - T_4)}{\Delta x} \Delta y + k \frac{(T_7 - T_4) \Delta x}{\Delta y} \frac{\Delta x}{2} = 0$$

$$\text{Node 5: } k \frac{(T_2 - T_5)}{\Delta y} \Delta x + k \frac{(T_6 - T_5)}{\Delta x} \Delta y + k \frac{(T_8 - T_5)}{\Delta y} \Delta x + k \frac{(T_4 - T_5)}{\Delta x} \Delta y = 0$$

$$\text{Node 6: } k \frac{(T_3 - T_6) \Delta x}{\Delta y} \frac{\Delta x}{2} + k \frac{(T_5 - T_6)}{\Delta x} \Delta y + k \frac{(T_9 - T_6) \Delta x}{\Delta y} \frac{\Delta x}{2} = 0$$

$$\text{Node 7: } k \frac{(T_4 - T_7) \Delta x}{\Delta y} \frac{\Delta x}{2} + k \frac{(T_8 - T_7)}{\Delta x} \Delta y + k \frac{(T_{10} - T_7) \Delta x}{\Delta y} \frac{\Delta x}{2} = 0$$

Continued...

### Problem 4.59 (Cont.)

Node 8:  $k \frac{(T_5 - T_8) \Delta x}{\Delta y} \frac{\Delta x}{2} + k \frac{(T_9 - T_8) \Delta y}{\Delta x} \Delta y + k \frac{(T_{11} - T_8) \Delta x}{\Delta y} \Delta x + k \frac{(T_7 - T_8) \Delta y}{\Delta x} \Delta y = 0$

Node 9:  $k \frac{(T_6 - T_9) \Delta x}{\Delta y} \frac{\Delta x}{2} + k \frac{(T_8 - T_9) \Delta y}{\Delta x} \Delta y + k \frac{(T_{12} - T_9) \Delta x}{\Delta y} \frac{\Delta x}{2} = 0$

Node 10:  $k \frac{(T_7 - T_{10}) \Delta x}{\Delta y} \frac{\Delta x}{2} + k \frac{(T_{11} - T_{10}) \Delta y}{\Delta x} \frac{\Delta y}{2} - q_1' = 0$

Node 11:  $k \frac{(T_8 - T_{11}) \Delta x}{\Delta y} \Delta x + k \frac{(T_{10} - T_{11}) \Delta y}{\Delta x} \frac{\Delta y}{2} + k \frac{(T_{12} - T_{11}) \Delta y}{\Delta x} \frac{\Delta y}{2} - q_2' = 0$

Node 12:  $k \frac{(T_9 - T_{12}) \Delta x}{\Delta y} \frac{\Delta x}{2} + k \frac{(T_{11} - T_{12}) \Delta y}{\Delta x} \frac{\Delta y}{2} - q_3' = 0$

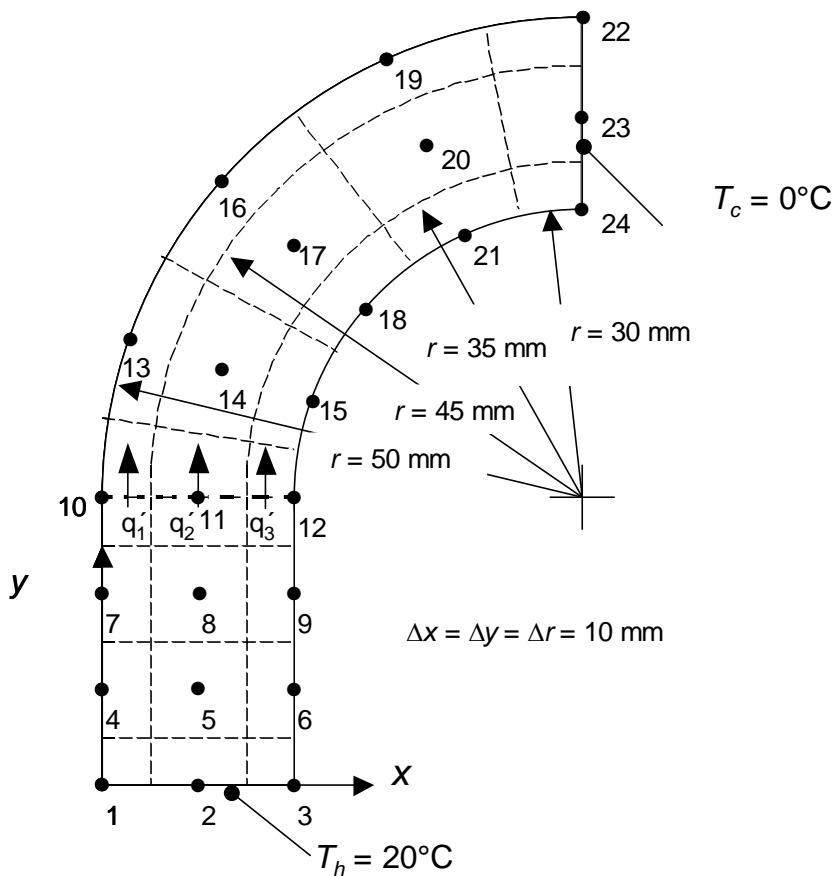

Continued...

### Problem 4.59 (Cont.)

Cylindrical Sub-Domain. We begin by recalling that Fourier's law for the cylindrical coordinate system yields

$$q_r'' = -k \frac{\partial T}{\partial r} \approx -k \frac{\Delta T}{\Delta r}; \quad q_\phi'' = -\frac{k}{r} \frac{\partial T}{\partial \phi} \approx -\frac{k}{r} \frac{\Delta T}{\Delta \phi}$$

and the areas through which conduction occurs in the radial direction increase as the radius increases.

Nodes 10, 13, 16, 19, 22, 23 and 24:  $T_{10} = T_{13} = T_{16} = T_{19} = T_{22} = T_{23} = T_{24} = T_c = 0^\circ\text{C}$

$$\text{Node 11: } q_2' + k \frac{(T_{12} - T_{11})}{\Delta r} \cdot 3.5\Delta r \cdot \frac{\Delta \phi}{2} + k \frac{(T_{14} - T_{11})}{4\Delta r \Delta \phi} \cdot \Delta r + k \frac{(T_{10} - T_{11})}{\Delta r} \cdot 4.5\Delta r \cdot \frac{\Delta \phi}{2} = 0$$

$$\text{Node 12: } q_3' + k \frac{(T_{11} - T_{12})}{\Delta r} \cdot 3.5\Delta r \cdot \frac{\Delta \phi}{2} + k \frac{(T_{15} - T_{12})}{3\Delta r \Delta \phi} \cdot \Delta r = 0$$

$$\text{Node 14: } k \frac{(T_{11} - T_{14})}{4\Delta r \Delta \phi} \cdot \Delta r + k \frac{(T_{15} - T_{14})}{\Delta r} \cdot 3.5\Delta r \Delta \phi + k \frac{(T_{17} - T_{14})}{4\Delta r \Delta \phi} \cdot \Delta r + k \frac{(T_{13} - T_{14})}{\Delta r} \cdot 4.5\Delta r \Delta \phi = 0$$

$$\text{Node 15: } k \frac{(T_{12} - T_{15})}{3\Delta r \Delta \phi} \cdot \frac{\Delta r}{2} + k \frac{(T_{14} - T_{15})}{\Delta r} \cdot 3.5\Delta r \Delta \phi + k \frac{(T_{18} - T_{15})}{3\Delta r \Delta \phi} \cdot \frac{\Delta r}{2} = 0$$

$$\text{Node 17: } k \frac{(T_{14} - T_{17})}{4\Delta r \Delta \phi} \cdot \Delta r + k \frac{(T_{18} - T_{17})}{\Delta r} \cdot 3.5\Delta r \Delta \phi + k \frac{(T_{20} - T_{17})}{4\Delta r \Delta \phi} \cdot \Delta r + k \frac{(T_{16} - T_{17})}{\Delta r} \cdot 4.5\Delta r \Delta \phi = 0$$

$$\text{Node 18: } k \frac{(T_{15} - T_{18})}{3\Delta r \Delta \phi} \cdot \frac{\Delta r}{2} + k \frac{(T_{17} - T_{18})}{\Delta r} \cdot 3.5\Delta r \Delta \phi + k \frac{(T_{21} - T_{18})}{3\Delta r \Delta \phi} \cdot \frac{\Delta r}{2} = 0$$

$$\text{Node 20: } k \frac{(T_{17} - T_{20})}{4\Delta r \Delta \phi} \cdot \Delta r + k \frac{(T_{21} - T_{20})}{\Delta r} \cdot 3.5\Delta r \Delta \phi + k \frac{(T_{23} - T_{20})}{4\Delta r \Delta \phi} \cdot \Delta r = 0$$

$$\text{Node 21: } k \frac{(T_{18} - T_{21})}{3\Delta r \Delta \phi} \cdot \frac{\Delta r}{2} + k \frac{(T_{20} - T_{21})}{\Delta r} \cdot 3.5\Delta r \Delta \phi + k \frac{(T_{24} - T_{21})}{3\Delta r \Delta \phi} \cdot \frac{\Delta r}{2} = 0$$

Note that energy balances for nodes 10, 11 and 12 are included in both the rectangular and cylindrical sub-domains. These energy balances couple the solutions for the two sub-domains together.

The preceding finite difference equations may be solved simultaneously with the *IHT* code provided in the Comment yielding the following temperatures and  $q' = 114.5 \text{ W/m}$ . <

The nodal temperatures are:

$T_1 = 20.00^\circ\text{C}$	$T_2 = 20.00^\circ\text{C}$	$T_3 = 20.00^\circ\text{C}$	$T_4 = 14.11^\circ\text{C}$	$T_5 = 14.29^\circ\text{C}$	$T_6 = 14.41^\circ\text{C}$
$T_7 = 7.86^\circ\text{C}$	$T_8 = 8.66^\circ\text{C}$	$T_9 = 9.03^\circ\text{C}$	$T_{10} = 0.00^\circ\text{C}$	$T_{11} = 3.46^\circ\text{C}$	$T_{12} = 4.40^\circ\text{C}$
$T_{13} = 0.00^\circ\text{C}$	$T_{14} = 1.04^\circ\text{C}$	$T_{15} = 1.59^\circ\text{C}$	$T_{16} = 0.00^\circ\text{C}$	$T_{17} = 0.33^\circ\text{C}$	$T_{18} = 0.54^\circ\text{C}$
$T_{19} = 0.00^\circ\text{C}$	$T_{20} = 0.10^\circ\text{C}$	$T_{21} = 0.16^\circ\text{C}$	$T_{22} = 0.00^\circ\text{C}$	$T_{23} = 0.00^\circ\text{C}$	$T_{24} = 0.00^\circ\text{C}$

Continued...

## Problem 4.59 (Cont.)

**COMMENTS:** (1) The *IHT* code is listed below. For each control volume, we note that  $\dot{E}_{in} = 0$  and  $\Delta y = \Delta x$ , yielding the following energy balances for all but the isothermal nodes.

```

// Input Parameters

Th = 20
Tc = 0
k = 10
deltaphi = pi/8

// Node Equations for Rectangle

//Node 1
T1 = Th
//Node 2
T2 = Th
//Node 3
T3 = Th
//Node 4
(T1 - T4)/2 + (T5 - T4) + (T7 - T4)/2 = 0
//Node 5
(T2 - T5) + (T6 - T5) + (T8 - T5) + (T4 - T5) = 0
//Node 6
(T3 - T6)/2 + (T5 - T6) + (T9 - T6)/2 = 0
//Node 7
(T4 - T7)/2 + (T8 - T7) + (T10 - T7)/2 = 0
//Node 8
(T5 - T8) + (T9 - T8) + (T11 - T8) + (T7 - T8) = 0
//Node 9
(T6 - T9)/2 + (T8 - T9) + (T12 - T9)/2 = 0

//Nodes Common to Both Sub-Domains (Rectangle)
//Node 10
(T7 - T10)/2 + (T11 - T10)/2 - qprime1/k = 0
//Node 11
(T8 - T11) + (T10 - T11)/2 + (T12 - T11)/2 - qprime2/k = 0
//Node 12
(T9 - T12)/2 + (T11 - T12)/2 - qprime3/k = 0

//Nodes Common to Both Sub-Domains (Cylindrical)
//Node 10
T10 = Tc
//Node 11
qprime2/k + (T12 - T11)*3.5*deltaphi/2 + (T14 - T11)/4/deltaphi + (T10 - T11)*4.5*deltaphi/2 = 0
//Node 12
qprime3/k + (T11 - T12)*3.5*deltaphi/2 + (T15 - T12)/3/deltaphi/2 = 0

// Node Equations for Cylindrical Region

//Node 13
T13 = Tc
//Node 14
(T11 - T14)/4/deltaphi + (T15 - T14)*3.5*deltaphi + (T17 - T14)/4/deltaphi + (T13 - T14)*4.5*deltaphi = 0
//Node 15
(T12 - T15)/3/deltaphi/2 + (T14 - T15)*3.5*deltaphi + (T18 - T15)/3/deltaphi/2 = 0
//Node 16
T16 = Tc
//Node 17
(T14 - T17)/4/deltaphi + (T18 - T17)*3.5*deltaphi + (T20 - T17)/4/deltaphi + (T16 - T17)*4.5*deltaphi = 0
//Node 18
(T15 - T18)/3/deltaphi/2 + (T17 - T18)*3.5*deltaphi + (T21 - T18)/3/deltaphi/2 = 0

```

Continued...

### Problem 4.59 (Cont.)

```
//Node 19
T19 = Tc
//Node 20
(T17 - T20)/4/deltaphi + (T21 - T20)*3.5*deltaphi + (T23 - T20)/4/deltaphi + (T19 - T20)*4.5*deltaphi =
0
//Node 21
(T18 - T21)/3/deltaphi/2 + (T20 - T21)*3.5*deltaphi + (T24 - T21)/3/deltaphi/2 = 0
//Node 22
T22 = Tc
//Node 23
T23 = Tc
//Node 24
T24 = Tc

qprime = qprime1 + qprime2 + qprime3
```

(2) The shape factor for the geometry is  $S = \frac{q'}{k(Th - Tc)} = \frac{114.5 \text{ W/m}}{10 \text{ W/m} \cdot \text{K} \times 20 \text{ K}} = 0.573$



### PROBLEM 4.60

**KNOWN:** Dimensions of a tube of non-circular cross section that can be broken into rectangular and cylindrical sub-domains. Fluid temperature and heat transfer coefficient, external surface temperature and tube wall thermal conductivity.

**FIND:** Heat transfer rate per unit length of tube.

**SCHEMATIC:**

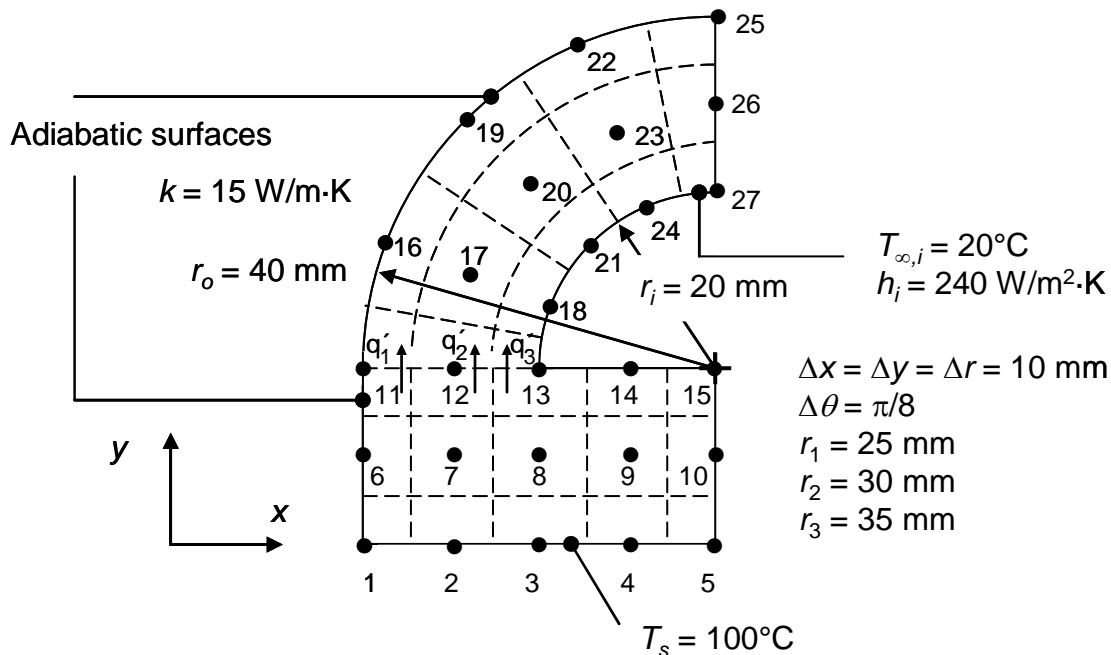

**ASSUMPTIONS:** (1) Steady-state conditions, (2) Constant properties, (3) No internal generation, (4) Two-dimensional conduction.

**ANALYSIS:** We may combine heat fluxes determined from Fourier's law with expressions for the size of the control surfaces of the various control volumes to determine the heat rate per unit depth into each control volume in the discretized domain. Application of conservation of energy for each control volume yields the expression  $\dot{E}_{in} = 0$ .

Rectangular Sub-Domain. For the rectangular sub-domain, application of Fourier's law in Cartesian coordinates along with conservation of energy yields the finite difference equations that are listed in the IHT code included in COMMENT (1).

Cylindrical Sub-Domain. For the cylindrical sub-domain, application of Fourier's law in cylindrical coordinates along with conservation of energy yields the finite difference equations that are listed in the IHT code included in COMMENT (1).

Coupling of Domains. Note that energy balances for Nodes 11, 12 and 13 are included in both the rectangular and cylindrical sub-domains. These energy balances couple the two solutions together.

Continued...

### PROBLEM 4.60 (Cont.)

The equations are solved simultaneously to yield the following nodal temperatures in degrees Celsius.

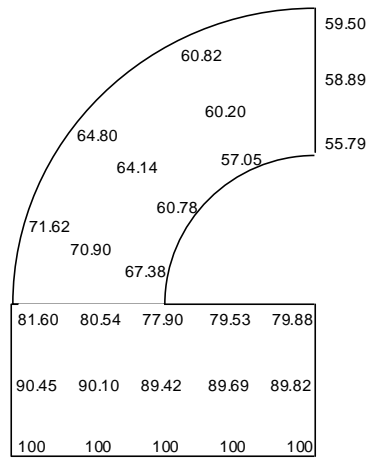

The heat transfer rate per unit depth may be expressed as

$$q' = 2 \left[ \frac{k\Delta x}{\Delta y} \right] \left[ (T_1 - T_6)/2 + (T_2 - T_7) + (T_3 - T_8) + (T_4 - T_9) + (T_5 - T_{10})/2 \right]$$

$$= 2 \times 15 \text{ W/m} \cdot \text{K} \times \left[ \begin{aligned} & (100 - 90.45)^\circ\text{C}/2 + (100 - 90.10)^\circ\text{C} + \\ & (100 - 89.42)^\circ\text{C} + (100 - 89.69)^\circ\text{C} \\ & + (100 - 89.82)^\circ\text{C}/2 \end{aligned} \right]$$

$$= 1220 \text{ W/m}$$

<

**COMMENTS:** (1) The *IHT* code is listed below. For each control volume, we note that  $\dot{E}_{in} = 0$ , yielding the energy balances for the rectangular and cylindrical sub-domains.

```
ri = 20/1000
ro = 40/1000
r1 = 25/1000
r2 = 30/1000
r3 = 35/1000
```

```
dx = 10/1000
dy = 10/1000
dr = 10/1000
dtheta = pi/8
```

Continued...

## PROBLEM 4.60 (Cont.)

k = 15  
h = 240  
Tinf = 20

T1 = 100  
T2 = 100  
T3 = 100  
T4 = 100  
T5 = 100

//Rectangular Domain

//Node 6

$$k*(T1 - T6)*(dx/2)/dy + k*(T7 - T6)*dy/dx + k*(T11 - T6)*(dx/2)/dy = 0$$

//Node 7

$$k*(T6 - T7)*dy/dx + k*(T12 - T7)*dx/dy + k*(T8 - T7)*dy/dx + k*(T2 - T7)*dx/dy = 0$$

//Node 8

$$k*(T7 - T8)*dy/dx + k*(T13 - T8)*dx/dy + k*(T9 - T8)*dy/dx + k*(T3 - T8)*dx/dy = 0$$

//Node 9

$$k*(T8 - T9)*dy/dx + k*(T14 - T9)*dx/dy + k*(T10 - T9)*dy/dx + k*(T4 - T9)*dx/dy = 0$$

//Node 10

$$k*(T9 - T10)*dy/dx + k*(T15 - T10)*(dx/2)/dy + k*(T5 - T10)*(dx/2)/dy = 0$$

//Node 11

$$k*(T6 - T11)*(dx/2)/dy + k*(T12 - T11)*(dy/2)/dx = qprime1$$

//Node 12

$$k*(T11 - T12)*(dy/2)/dx + k*(T7 - T12)*dx/dy + k*(T13 - T12)*(dy/2)/dx = qprime2$$

//Node 13

$$k*(T12 - T13)*(dy/2)/dx + k*(T14 - T13)*(dy/2)/dx + k*(T8 - T13)*dx/dy + h*(dx/2)*(Tinf - T13) = qprime3$$

//Node 14

$$k*(T13 - T14)*(dy/2)/dx + k*(T9 - T14)*dx/dy + k*(T15 - T14)*(dy/2)/dx + h*dx*(Tinf - T14) = 0$$

//Node 15

$$k*(T14 - T15)*(dy/2)/dx + k*(T10 - T15)*(dx/2)/dy + h*(dx/2)*(Tinf - T15) = 0$$

//Cylindrical Domain

//Node 11

$$k*(T16 - T11)*(dr/2)/(ro*dtheta) + k*(T12 - T11)*(r3*dtheta/2)/dr + qprime1 = 0$$

//Node 12

$$k*(T11 - T12)*(r3*dtheta/2)/dr + k*(T17 - T12)*dr/(r2*dtheta) + k*(T13 - T12)*(r1*dtheta/2)/dr + qprime2 = 0$$

//Node 13

$$k*(T12 - T13)*(r1*dtheta/2)/dr + k*(T18 - T13)*(dr/2)/(ri*dtheta) + qprime3 + h*(ri*dtheta/2)*(Tinf - T13) = 0$$

//Node 16

$$k*(T11 - T16)*(dr/2)/(ro*dtheta) + k*(T17 - T16)*(r3*dtheta)/dr + k*(T19 - T16)*(dr/2)/(ro*dtheta) = 0$$

//Node 17

$$k*(T16 - T17)*(r3*dtheta)/dr + k*(T20 - T17)*dr/(r2*dtheta) + k*(T18 - T17)*(r1*dtheta)/dr + k*(T12 - T17)*dr/(r2*dtheta) = 0$$

//Node 18

$$k*(T13 - T18)*(dr/2)/(ri*dtheta) + k*(T17 - T18)*(r1*dtheta)/dr + k*(T21 - T18)*(dr/2)/(ri*dtheta) + h*(ri*dtheta)*(Tinf - T18) = 0$$

//Node 19

$$k*(T16 - T19)*(dr/2)/(ro*dtheta) + k*(T20 - T19)*(r3*dtheta)/dr + k*(T22 - T19)*(dr/2)/(ro*dtheta) = 0$$

//Node 20

$$k*(T19 - T20)*(r3*dtheta)/dr + k*(T23 - T20)*dr/(r2*dtheta) + k*(T21 - T20)*(r1*dtheta)/dr + k*(T17 - T20)*dr/(r2*dtheta) = 0$$

//Node 21

$$k*(T18 - T21)*(dr/2)/(ri*dtheta) + k*(T20 - T21)*(r1*dtheta)/dr + k*(T24 - T21)*(dr/2)/(ri*dtheta) + h*(ri*dtheta)*(Tinf - T21) = 0$$

//Node 22

$$k*(T19 - T22)*(dr/2)/(ro*dtheta) + k*(T23 - T22)*(r3*dtheta)/dr + k*(T25 - T22)*(dr/2)/(ro*dtheta) = 0$$

//Node 23

$$k*(T22 - T23)*(r3*dtheta)/dr + k*(T26 - T23)*dr/(r2*dtheta) + k*(T24 - T23)*(r1*dtheta)/dr + k*(T20 - T23)*dr/(r2*dtheta) = 0$$

//Node 24

$$k*(T21 - T24)*(dr/2)/(ri*dtheta) + k*(T23 - T24)*(r1*dtheta)/dr + k*(T27 - T24)*(dr/2)/(ri*dtheta) + h*(ri*dtheta)*(Tinf - T24) = 0$$

Continued...

### PROBLEM 4.60 (Cont.)

```
//Node 25
k*(T22 - T25)*(dr/2)/(ro*dtheta) + k*(T26 - T25)*(r3*dtheta/2)/dr = 0
//Node 26
k*(T25 - T26)*(r3*dtheta/2)/dr + k*(T23 - T26)*dr/(r2*dtheta) + k*(T27 - T26)*(r1*dtheta/2)/dr = 0
//Node 27
k*(T24 - T27)*(dr/2)/(ri*dtheta) + k*(T26 - T27)*(r1*dtheta/2)/dr + h*(ri*dtheta/2)*(Tinf - T24) = 0

//Heat Transfer Rate Per Unit Depth (W/m)
qprime = 2*((k/dy)*((T1 - T6)*dx/2 + (T2 - T7)*dx + (T3 - T8)*dx + (T4 - T9)*dx + (T5 - T10)*dx/2))
```

(2) For an isothermal tube at  $T_s = 100^\circ\text{C}$ , the heat transfer per unit length is

$$q' = h(\pi r_i + 2r_i) \times (T_s - T_\infty) = 240 \text{ W/m} \cdot \text{K} \times (\pi \times 20 \times 10^{-3} \text{ m} + 2 \times 20 \times 10^{-3} \text{ m}) \times (100 - 20)^\circ\text{C}$$

= 1975 W/m. The conduction resistance posed by the tube wall is responsible for decreasing the actual heat transfer rate below this value.

## PROBLEM 4.61

**KNOWN:** Steady-state temperatures ( $^{\circ}\text{C}$ ) associated with selected nodal points in a two-dimensional system.

**FIND:** (a) Temperatures at nodes 1, 2 and 3, (b) Heat transfer rate per unit thickness from the system surface to the fluid.

**SCHEMATIC:**

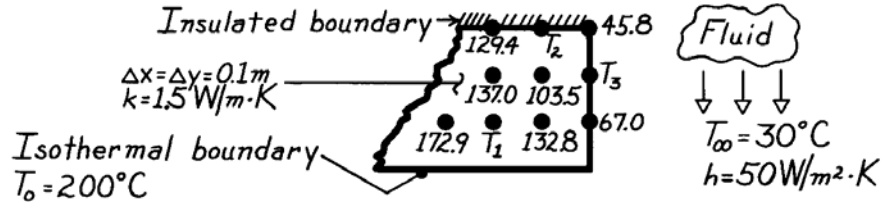

**ASSUMPTIONS:** (1) Steady-state, two-dimensional conduction, (2) Constant properties.

**ANALYSIS:** (a) Using the finite-difference equations for Nodes 1, 2 and 3:

Node 1, Interior node, Eq. 4.29:  $T_1 = \frac{1}{4} \cdot \sum T_{\text{neighbors}}$

$$T_1 = \frac{1}{4} (172.9 + 137.0 + 132.8 + 200.0)^{\circ}\text{C} = 160.7^{\circ}\text{C} \quad <$$

Node 2, Insulated boundary, Eq. 4.46 with  $h = 0$ ,  $T_{m,n} = T_2$

$$T_2 = \frac{1}{4} (T_{m-1,n} + T_{m+1,n} + 2T_{m,n-1})$$

$$T_2 = \frac{1}{4} (129.4 + 45.8 + 2 \times 103.5)^{\circ}\text{C} = 95.6^{\circ}\text{C} \quad <$$

Node 3, Plane surface with convection, Eq. 4.42,  $T_{m,n} = T_3$

$$2 \left[ \frac{h\Delta x}{k} + 2 \right] T_3 = (2T_{m-1,n} + T_{m,n+1} + T_{m,n-1}) + \frac{2h\Delta x}{k} T_{\infty}$$

$$h\Delta x/k = 50\text{W/m}^2 \cdot \text{K} \times 0.1\text{m} / 1.5\text{W/m} \cdot \text{K} = 3.33$$

$$2(3.33 + 2)T_3 = (2 \times 103.5 + 45.8 + 67.0)^{\circ}\text{C} + 2 \times 3.33 \times 30^{\circ}\text{C}$$

$$T_3 = \frac{1}{10.66} (319.80 + 199.80)^{\circ}\text{C} = 48.7^{\circ}\text{C} \quad <$$

(b) The heat rate per unit thickness from the surface to the fluid is determined from the sum of the convection rates from each control volume surface.

$$q'_{\text{conv}} = q'_a + q'_b + q'_c + q'_d$$

$$q_i = h\Delta y_i (T_i - T_{\infty})$$

$$q'_{\text{conv}} = 50 \frac{\text{W}}{\text{m}^2 \cdot \text{K}} \left[ \frac{0.1}{2} \text{m} (45.8 - 30.0)^{\circ}\text{C} + 0.1\text{m} (48.7 - 30.0)^{\circ}\text{C} + 0.1\text{m} (67.0 - 30.0)^{\circ}\text{C} + \frac{0.1\text{m}}{2} (200.0 - 30.0)^{\circ}\text{C} \right]$$

$$q'_{\text{conv}} = (39.5 + 93.5 + 185.0 + 425) \text{W/m} = 743 \text{W/m.} \quad <$$

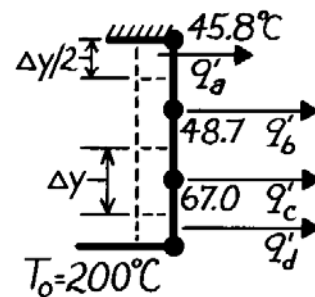
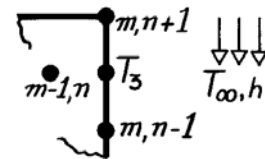
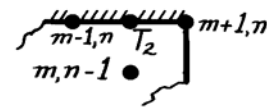
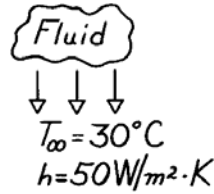

### PROBLEM 4.62

**KNOWN:** Nodal temperatures from a steady-state finite-difference analysis for a cylindrical fin of prescribed diameter, thermal conductivity and convection conditions ( $T_\infty$ ,  $h$ ).

**FIND:** (a) The fin heat rate,  $q_f$ , and (b) Temperature at node 3,  $T_3$ .

**SCHEMATIC:**

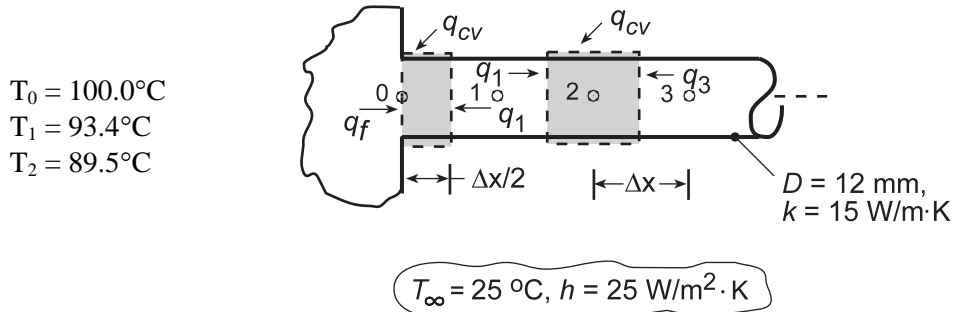

**ASSUMPTIONS:** (a) The fin heat rate,  $q_f$ , is that of conduction at the base plane,  $x = 0$ , and can be found from an energy balance on the control volume about node 0,  $\dot{E}_{\text{in}} - \dot{E}_{\text{out}} = 0$ ,

$$q_f + q_1 + q_{\text{conv}} = 0 \quad \text{or} \quad q_f = -q_1 - q_{\text{conv}}.$$

Writing the appropriate rate equation for  $q_1$  and  $q_{\text{conv}}$ , with  $A_c = \pi D^2/4$  and  $P = \pi D$ ,

$$q_f = -kA_c \frac{T_1 - T_0}{\Delta x} - hP(\Delta x/2)(T_\infty - T_0) = -\frac{\pi k D^2}{4\Delta x}(T_1 - T_0) - (\pi/2)Dh\Delta x(T_\infty - T_0)$$

Substituting numerical values, with  $\Delta x = 0.010 \text{ m}$ , find

$$q_f = -\frac{\pi \times 15 \text{ W/m}\cdot\text{K} (0.012 \text{ m})^2}{4 \times 0.010 \text{ m}} (93.4 - 100)^\circ\text{C} - \frac{\pi}{2} \times 0.012 \text{ m} \times 25 \text{ W/m}^2\cdot\text{K} \times 0.010 \text{ m} (25 - 100)^\circ\text{C}$$

$$q_f = (1.120 + 0.353) \text{ W} = 1.473 \text{ W} .$$

<

(b) To determine  $T_3$ , derive the finite-difference equation for node 3, perform an energy balance on the control volume shown above,  $\dot{E}_{\text{in}} - \dot{E}_{\text{out}} = 0$ ,

$$q_{\text{cv}} + q_3 + q_1 = 0$$

$$hP\Delta x(T_\infty - T_2) + kA_c \frac{T_3 - T_2}{\Delta x} + kA_c \frac{T_1 - T_2}{\Delta x} = 0$$

$$T_3 = -T_1 + 2T_2 - \frac{hP\Delta x^2}{kA_c} [T_\infty - T_2]$$

Substituting numerical values, find

$$T_3 = 89.2^\circ\text{C}$$

<

**COMMENTS:** Note that in part (a), the convection heat rate from the outer surface of the control volume is significant (25%). It would have been a poor approximation to ignore this term.

### PROBLEM 4.63

**KNOWN:** Dimensions of a two-dimensional object with isothermal and adiabatic boundaries.

**FIND:** (a) Estimate of the shape factor using a one-dimensional analysis and (b) estimate of the shape factor using a finite difference method with  $\Delta x = \Delta y = 0.05 L$ .

**SCHEMATIC:**

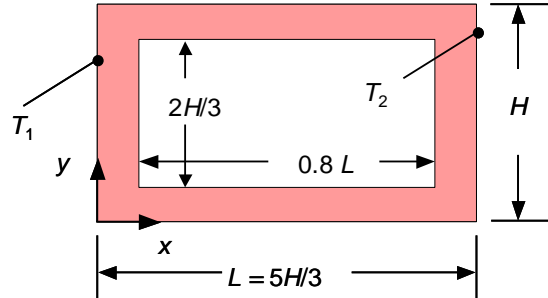

**ASSUMPTIONS:** (1) Steady-state conditions, (2) Constant properties, (3) No internal generation, (4) One-dimensional conduction in part (a), (5) Two-dimensional conduction in part (b).

**ANALYSIS:** (a) As a first approximation, we ignore conduction in the cross-hatched regions.

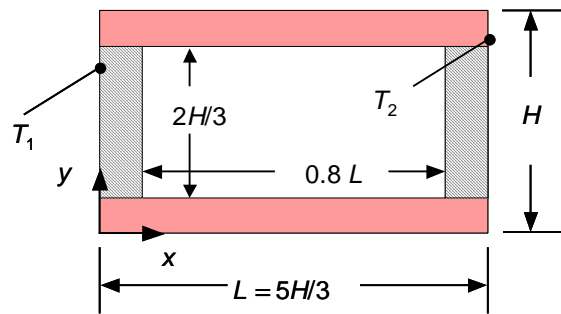

Hence,

$$q' = Sk(T_1 - T_2) \approx (H/3)k(T_1 - T_2)/L = k(T_1 - T_2)/5$$

Therefore,  $S \approx 0.20$ .

<

(b) We begin by taking advantage of the symmetry of the problem. Recognize that the line  $y = H/2$  is an adiabat, and the line  $x = L/2$  is an isotherm at  $T = (T_1 + T_2)/2$ . Hence, only one quarter of the domain needs to be modeled. Arbitrarily, we select the upper left quarter for analysis. Note that  $\Delta x = \Delta y$ .

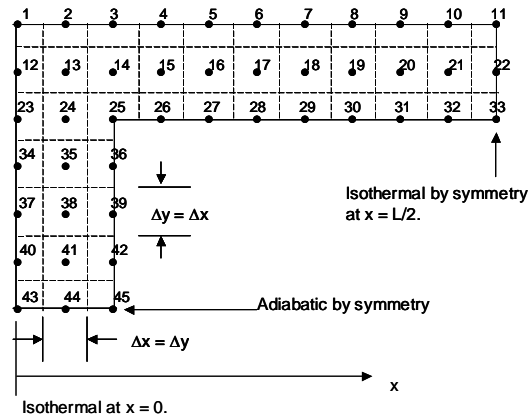

Continued...

### Problem 4.63 (Cont.)

We may use the finite difference equations from the text, or note that for each node, an energy balance can be written for the corresponding control volume. Consider, for example, the control volume about Node 2 for which we may write

$$k \times \frac{\Delta y}{2} \frac{(T_1 - T_2)}{\Delta x} + k \times \frac{\Delta x (T_{13} - T_2)}{\Delta y} + k \times \frac{\Delta y}{2} \frac{(T_3 - T_2)}{\Delta x} = 0$$

or

$$\frac{(T_1 - T_2)}{2} + (T_{13} - T_2) + \frac{(T_3 - T_2)}{2} = 0$$

We let the temperature at  $x = 0$  be  $T_1 = 1$  and the temperature at  $x = L/2$  be  $T_2 = 0.5$ . The 45 equations are solved simultaneously with the *IHT* code provided in the Comment. The resulting nodal temperatures in the upper left corner are:

1.0000	0.9636	0.9226	0.8737	0.8215	0.7683	0.7147	0.6610	0.6074	0.5537	0.5000
1.0000	0.9659	0.9265	0.8753	0.8220	0.7684	0.7147	0.6611	0.6074	0.5537	0.5000
1.0000	0.9734	0.9423	0.8790	0.8229	0.7686	0.7148	0.6611	0.6074	0.5537	0.5000
1.0000	0.9853	0.9753								
1.0000	0.9923	0.9884								
1.0000	0.9957	0.9938								
1.0000	0.9966	0.9952								

After solving for the temperatures, the heat transfer rate per unit depth may be evaluated at any  $x$  location, and for  $x = L/2$  it may be expressed as

$$q' = k \left[ \frac{\Delta y/2}{\Delta x} (T_{10} - T_{11}) + \frac{\Delta y}{\Delta x} (T_{21} - T_{22}) + \frac{\Delta y/2}{\Delta x} (T_{32} - T_{33}) \right] \quad (1)$$

or, in terms of the shape factor,

$$q' = Sk(T_h - T_c) \quad (2)$$

Equating Eqs. (1) and (2) yields the shape factor,  $S \approx 0.215$ . <

We note that the shape factor calculated with the finite difference approach is only slightly greater than the shape factor based upon the one-dimensional approximation. The good agreement is expected since the major resistance to heat transfer is posed by the top and bottom slender regions that connect the two isothermal boundaries. We also note that temperatures are nearly isothermal in the region  $y \approx H/2$  due to the adiabatic interior.

Continued...



### Problem 4.63 (Cont.)

**COMMENTS:** The *IHT* code is listed below. For each control volume, we note that  $\dot{E}_{in} = 0$  and  $\Delta y = \Delta x$ , yielding the following energy balances for all but the isothermal nodes.

```
Th = 1
Tc = 0.5

//Top Row

//Node 1
T1 = Th
//Node 2
(T1 - T2)/2 + (T3 - T2)/2 + (T13 - T2) = 0
//Node 3
(T2 - T3)/2 + (T4 - T3)/2 + (T14 - T3) = 0
//Node 4
(T3 - T4)/2 + (T5 - T4)/2 + (T15 - T4) = 0
//Node 5
(T4 - T5)/2 + (T6 - T5)/2 + (T16 - T5) = 0
//Node 6
(T5 - T6)/2 + (T7 - T6)/2 + (T17 - T6) = 0
//Node 7
(T6 - T7)/2 + (T8 - T7)/2 + (T18 - T7) = 0
//Node 8
(T7 - T8)/2 + (T9 - T8)/2 + (T19 - T8) = 0
//Node 9
(T8 - T9)/2 + (T10 - T9)/2 + (T20 - T9) = 0
//Node 10
(T9 - T10)/2 + (T11 - T10)/2 + (T21 - T10) = 0
//Node 11
T11 = Tc

//Second Row from Top

//Node 12
T12 = Th
//Node 13
(T12 - T13) + (T2 - T13) + (T14 - T13) + (T24 - T13) = 0
//Node 14
(T13 - T14) + (T3 - T14) + (T15 - T14) + (T25 - T14) = 0
//Node 15
(T14 - T15) + (T4 - T15) + (T16 - T15) + (T26 - T15) = 0
//Node 16
(T15 - T16) + (T5 - T16) + (T17 - T16) + (T27 - T16) = 0
//Node 17
(T16 - T17) + (T6 - T17) + (T18 - T17) + (T28 - T17) = 0
//Node 18
(T17 - T18) + (T7 - T18) + (T19 - T18) + (T29 - T18) = 0
//Node 19
(T18 - T19) + (T8 - T19) + (T20 - T19) + (T30 - T19) = 0
//Node 20
(T19 - T20) + (T9 - T20) + (T21 - T20) + (T31 - T20) = 0
//Node 21
(T20 - T21) + (T10 - T21) + (T22 - T21) + (T32 - T21) = 0
//Node 22
T22 = Tc

//Third Row from Top

//Node 23
T23 = Th
//Node 24
(T23 - T24) + (T13 - T24) + (T25 - T24) + (T35 - T24) = 0
//Node 25
(T24 - T25) + (T14 - T25) + (T26 - T25)/2 + (T36 - T25)/2 = 0
//Node 26
```

Continued...

## Problem 4.63 (Cont.)

```
(T25 - T26)/2 + (T15 - T26) + (T27 - T26)/2 = 0
//Node 27
(T26 - T27)/2 + (T16 - T27) + (T28 - T27)/2 = 0
//Node 28
(T27 - T28)/2 + (T17 - T28) + (T29 - T28)/2 = 0
//Node 29
(T28 - T29)/2 + (T18 - T29) + (T30 - T29)/2 = 0
//Node 30
(T29 - T30)/2 + (T19 - T30) + (T31 - T30)/2 = 0
//Node 31
(T30 - T31)/2 + (T20 - T31) + (T32 - T31)/2 = 0
//Node 32
(T31 - T32)/2 + (T21 - T32) + (T33 - T32)/2 = 0
//Node 33
T33 = Tc

//Fourth Row from Top

//Node 34
T34 = Th
//Node 35
(T34 - T35) + (T24 - T35) + (T36 - T35) + (T38 - T35) = 0
//Node 36
(T35 - T36) + (T25 - T36)/2 + (T39 - T36)/2 = 0

//Fifth Row from Top

//Node 37
T37 = Th
//Node 38
(T37 - T38) + (T35 - T38) + (T39 - T38) + (T41 - T38) = 0
//Node 39
(T38 - T39) + (T36 - T39)/2 + (T42 - T39)/2 = 0

//Sixth Row from Top
//Node 40
T40 = Th
//Node 41
(T40 - T41) + (T38 - T41) + (T42 - T41) + (T44 - T41) = 0
//Node 42
(T41 - T42) + (T39 - T42)/2 + (T45 - T42)/2 = 0

//Bottom Row
//Node 43
T43 = Th
//Node 44
(T43 - T44)/2 + (T41 - T44) + (T45 - T44)/2 = 0
//Node 45
(T44 - T45)/2 + (T42 - T45)/2 = 0

//Shape Factor
H = 1
L = H*5/3
k = 1
deltay = 0.05*L
deltax = deltay

//Heat Rate at RHS of Computational Domain (W/m)
qprime = ((T10 - T11)*k*deltay/2)/deltax + ((T21 - T22)*k*deltay)/deltax + ((T32 - T33)*k*deltay/2)/deltax
qprime = S*k*(Th - Tc)
```

### PROBLEM 4.64

**KNOWN:** Square shape subjected to uniform surface temperature conditions.

**FIND:** (a) Temperature at the four specified nodes; estimate the midpoint temperature  $T_o$ , (b) Reducing the mesh size by a factor of 2, determine the corresponding nodal temperatures and compare results, and (c) For the finer grid, plot the 75, 150, and 250°C isotherms.

**SCHEMATIC:**

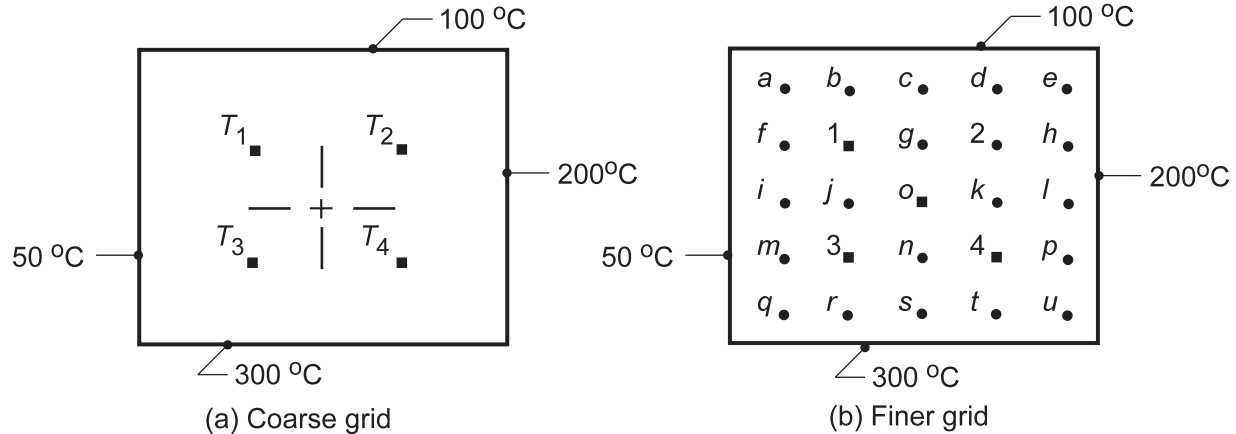

**ASSUMPTIONS:** (1) Steady-state, two-dimensional conduction, (2) Constant properties.

**ANALYSIS:** (a) The finite-difference equation for each node follows from Eq. 4.29 for an interior point written in the form,  $T_i = 1/4 \sum T_{\text{neighbors}}$ . Using the Gauss-Seidel iteration method, Section 4.5.2, the finite-difference equations for the four nodes are:

$$T_1^k = 0.25(100 + T_2^{k-1} + T_3^{k-1} + 50) = 0.25T_2^{k-1} + 0.25T_3^{k-1} + 37.5$$

$$T_2^k = 0.25(100 + 200 + T_4^{k-1} + T_1^{k-1}) = 0.25T_1^{k-1} + 0.25T_4^{k-1} + 75.0$$

$$T_3^k = 0.25(T_1^{k-1} + T_4^{k-1} + 300 + 50) = 0.25T_1^{k-1} + 0.25T_4^{k-1} + 87.5$$

$$T_4^k = 0.25(T_2^{k-1} + 200 + 300 + T_3^{k-1}) = 0.25T_2^{k-1} + 0.25T_3^{k-1} + 125.0$$

The iteration procedure using a hand calculator is implemented in the table below. Initial estimates are entered on the  $k = 0$  row.

k	$T_1$ (°C)	$T_2$ (°C)	$T_3$ (°C)	$T_4$ (°C)
0	100	150	150	250
1	112.50	165.63	178.13	210.94
2	123.44	158.60	171.10	207.43
3	119.93	156.40	169.34	206.55
4	119.05	156.40	168.90	206.33
5	118.83	156.29	168.79	206.27
6	118.77	156.26	168.76	206.26
7	118.76	156.25	168.76	206.25

<

Continued...

**PROBLEM 4.64 (Cont.)**

By the seventh iteration, the convergence is approximately 0.01°C. The midpoint temperature can be estimated as

$$T_o = (T_1 + T_2 + T_3 + T_4)/4 = (118.76 + 156.25 + 168.76 + 206.25)^\circ \text{C}/4 = 162.5^\circ \text{C}$$

(b) Because all the nodes are interior ones, the nodal equations can be written by inspection directly into the IHT workspace and the set of equations solved for the nodal temperatures (°C).

Mesh	$T_o$	$T_1$	$T_2$	$T_3$	$T_4$
Coarse	162.5	118.8	156.3	168.8	206.3
Fine	162.5	117.4	156.1	168.9	207.6

The maximum difference for the interior points is 1.4°C (node 1), but the estimate at the center,  $T_o$ , is the same, independently of the mesh size. In terms of the boundary surface temperatures,

$$T_o = (50 + 100 + 200 + 300)^\circ \text{C}/4 = 162.5^\circ \text{C}$$

Why must this be so?

(c) To generate the isotherms, it would be necessary to employ a contour-drawing routine using the tabulated temperature distribution (°C) obtained from the finite-difference solution. Using these values as a guide, try sketching a few isotherms.

-	100	100	100	100	100	-
50	86.0	105.6	119	131.7	151.6	200
50	88.2	117.4	138.7	156.1	174.6	200
50	99.6	137.1	162.5	179.2	190.8	200
50	123.0	168.9	194.9	207.6	209.4	200
50	173.4	220.7	240.6	246.8	239.0	200
-	300	300	300	300	300	-

**COMMENTS:** Recognize that this finite-difference solution is only an approximation to the temperature distribution, since the heat conduction equation has been solved for only four (or 25) discrete points rather than for all points if an analytical solution had been obtained.

## PROBLEM 4.65

**KNOWN:** Long bar of square cross section, three sides of which are maintained at a constant temperature while the fourth side is subjected to a convection process.

**FIND:** (a) The mid-point temperature and heat transfer rate between the bar and fluid; a numerical technique with grid spacing of 0.2 m is suggested, and (b) Reducing the grid spacing by a factor of 2, find the midpoint temperature and the heat transfer rate. Also, plot temperature distribution across the surface exposed to the fluid.

**SCHEMATIC:**

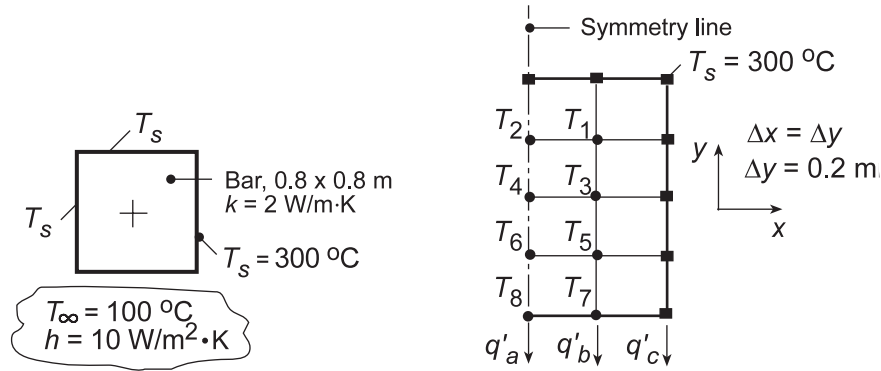

**ASSUMPTIONS:** (1) Steady-state, two-dimensional conduction, (2) Constant properties.

**ANALYSIS:** (a) Considering symmetry, the nodal network is shown above. The matrix inversion method of solution will be employed. The finite-difference equations are:

- Nodes 1, 3, 5 -* Interior nodes, Eq. 4.29; written by inspection.
- Nodes 2, 4, 6 -* Also can be treated as interior points, considering symmetry.
- Nodes 7, 8 -* On a plane with convection, Eq. 4.42; noting that  $h\Delta x/k = 10 \text{ W/m}^2\cdot\text{K} \times 0.2 \text{ m}/2\text{ W/m}\cdot\text{K} = 1$ , find
  - Node 7:  $(2T_5 + 300 + T_8) + 2 \times 1 \cdot 100 - 2(1+2)T_7 = 0$
  - Node 8:  $(2T_6 + T_7 + T_7) + 2 \times 1 \cdot 100 - 2(1+2)T_8 = 0$

The solution matrix [T] can be found using a stock matrix program using the [A] and [C] matrices shown below to obtain the solution matrix [T] (Eq. 4.48). Alternatively, the set of equations could be entered into the IHT workspace and solved for the nodal temperatures.

$$\mathbf{A} = \begin{bmatrix} -4 & 1 & 1 & 0 & 0 & 0 & 0 & 0 \\ 2 & -4 & 0 & 1 & 0 & 0 & 0 & 0 \\ 1 & 0 & -4 & 1 & 1 & 0 & 0 & 0 \\ 0 & 1 & 2 & -4 & 0 & 1 & 0 & 0 \\ 0 & 0 & 1 & 0 & -4 & 1 & 1 & 0 \\ 0 & 0 & 0 & 1 & 2 & -4 & 0 & 1 \\ 0 & 0 & 0 & 0 & 2 & 0 & -6 & 1 \\ 0 & 0 & 0 & 0 & 0 & 2 & 2 & -6 \end{bmatrix} \quad \mathbf{C} = \begin{bmatrix} -600 \\ -300 \\ -300 \\ 0 \\ -300 \\ 0 \\ -500 \\ -200 \end{bmatrix} \quad \mathbf{T} = \begin{bmatrix} 292.2 \\ 289.2 \\ 279.7 \\ 272.2 \\ 254.5 \\ 240.1 \\ 198.1 \\ 179.4 \end{bmatrix}$$

From the solution matrix, [T], find the mid-point temperature as

$$T_4 = 272.2^\circ\text{C}$$

<  
Continued...

### PROBLEM 4.65 (Cont.)

The heat rate by convection between the bar and fluid is given as,

$$q'_{\text{conv}} = 2(q'_a + q'_b + q'_c)$$

$$q'_{\text{conv}} = 2 \left[ h(\Delta x/2)(T_8 - T_\infty) + h(\Delta x)(T_7 - T_\infty) + h(\Delta x/2)(300 - T_\infty) \right]$$

$$q'_{\text{conv}} = 2 \left[ 10 \text{ W/m}^2 \cdot \text{K} \times (0.2 \text{ m}/2) \left[ (179.4 - 100) + 2(198.1 - 100) + (300 - 100) \right] \text{ K} \right]$$

$$q'_{\text{conv}} = 952 \text{ W/m}.$$

<

(b) Reducing the grid spacing by a factor of 2, the nodal arrangement will appear as shown. The finite-difference equation for the interior and centerline nodes were written by inspection and entered into the IHT workspace. The *IHT Finite-Difference Equations Tool* for 2-D, SS conditions, was used to obtain the FDE for the nodes on the exposed surface.

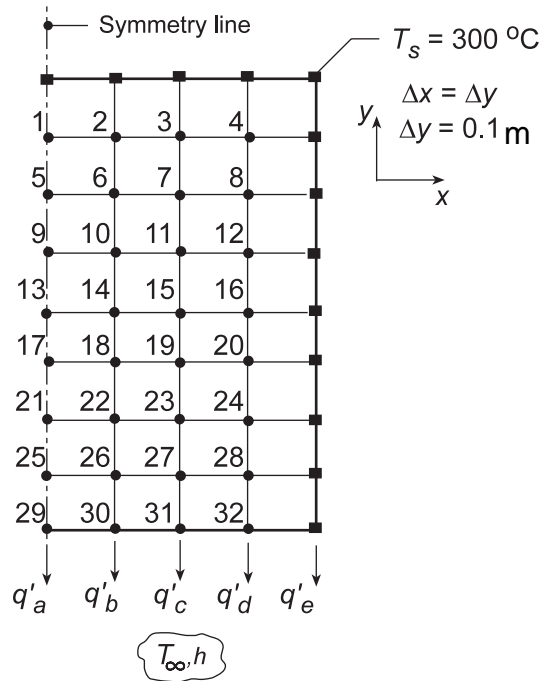

The midpoint temperature  $T_{13}$  and heat rate for the finer mesh are

$$T_{13} = 271.0^\circ\text{C} \quad q' = 834 \text{ W/m}$$

<

**COMMENTS:** The midpoint temperatures for the coarse and finer meshes agree closely,  $T_4 = 272^\circ\text{C}$  vs.  $T_{13} = 271.0^\circ\text{C}$ , respectively. However, the estimate for the heat rate is substantially influenced by the mesh size;  $q' = 952$  vs.  $834 \text{ W/m}$  for the coarse and finer meshes, respectively.

### PROBLEM 4.66

**KNOWN:** Dimensions of a two-dimensional, straight triangular fin. Fin base and ambient temperatures, thermal conductivity and heat transfer coefficient.

**FIND:** Fin efficiency by using a finite difference solution with specified grid.

**SCHEMATIC:**

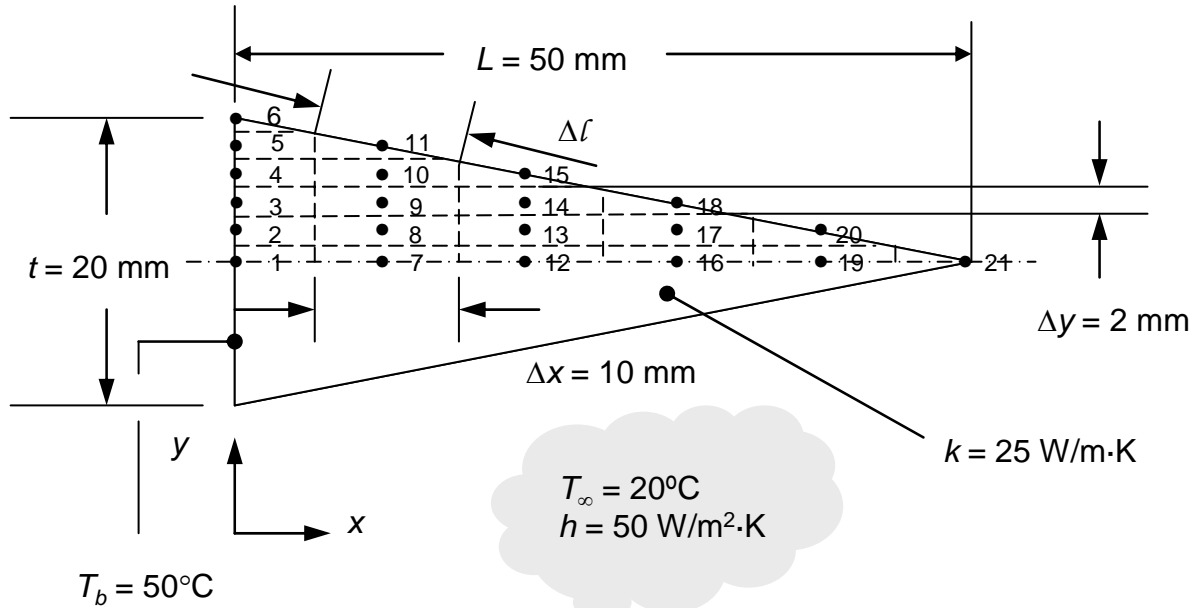

**ASSUMPTIONS:** (1) Steady-state conditions, (2) Constant properties, (3) No internal generation, (4) Two-dimensional conduction.

**ANALYSIS:** We may combine heat fluxes determined from Fourier's law and Newton's law of cooling with expressions for the size of the control surfaces of the various control volumes to determine the heat rate per unit depth into each control volume within the discretized domain.

Application of conservation of energy for each control volume yields the expression  $\dot{E}_{\text{in}} = 0$ . Note that  $\Delta l = \sqrt{\Delta x^2 + \Delta y^2} = 10.198 \text{ mm}$ .

Nodes 1, 2, 3, 4, 5 and 6:  $T_1 = T_2 = T_3 = T_4 = T_5 = T_6 = T_b = 50^\circ\text{C}$ .

$$\text{Node 7: } \frac{k(T_1 - T_7)(\Delta y/2)}{\Delta x} + \frac{k(T_8 - T_7)\Delta x}{\Delta y} + \frac{k(T_{12} - T_7)(\Delta y/2)}{\Delta x} = 0$$

$$\text{Node 8: } \frac{k(T_2 - T_8)(\Delta y)}{\Delta x} + \frac{k(T_7 - T_8)\Delta x}{\Delta y} + \frac{k(T_{13} - T_8)(\Delta y)}{\Delta x} + \frac{k(T_9 - T_8)(\Delta x)}{\Delta y} = 0$$

$$\text{Node 9: } \frac{k(T_3 - T_9)(\Delta y)}{\Delta x} + \frac{k(T_8 - T_9)\Delta x}{\Delta y} + \frac{k(T_{14} - T_9)(\Delta y)}{\Delta x} + \frac{k(T_{10} - T_9)(\Delta x)}{\Delta y} = 0$$

$$\text{Node 10: } \frac{k(T_4 - T_{10})(\Delta y)}{\Delta x} + \frac{k(T_9 - T_{10})\Delta x}{\Delta y} + \frac{k(T_{15} - T_{10})(\Delta y)}{\Delta x} + \frac{k(T_{11} - T_{10})(\Delta x)}{\Delta y} = 0$$

$$\text{Node 11: } \frac{k(T_5 - T_{11})(\Delta y)}{\Delta x} + \frac{k(T_{10} - T_{11})\Delta x}{\Delta y} + h\Delta l(T_\infty - T_{11}) = 0$$

Continued...

**PROBLEM 4.66 (Cont.)**

$$\text{Node 12: } \frac{k(T_7 - T_{12})(\Delta y/2)}{\Delta x} + \frac{k(T_{13} - T_{12})\Delta x}{\Delta y} + \frac{k(T_{16} - T_{12})(\Delta y/2)}{\Delta x} = 0$$

$$\text{Node 13: } \frac{k(T_8 - T_{13})(\Delta y)}{\Delta x} + \frac{k(T_{12} - T_{13})\Delta x}{\Delta y} + \frac{k(T_{17} - T_{13})(\Delta y)}{\Delta x} + \frac{k(T_{14} - T_{13})(\Delta x)}{\Delta y} = 0$$

$$\text{Node 14: } \frac{k(T_9 - T_{14})(\Delta y)}{\Delta x} + \frac{k(T_{13} - T_{14})\Delta x}{\Delta y} + \frac{k(T_{18} - T_{14})(\Delta y)}{\Delta x} + \frac{k(T_{15} - T_{14})(\Delta x)}{\Delta y} = 0$$

$$\text{Node 15: } \frac{k(T_{10} - T_{15})(\Delta y)}{\Delta x} + \frac{k(T_{14} - T_{15})\Delta x}{\Delta y} + h\Delta l(T_\infty - T_{15}) = 0$$

$$\text{Node 16: } \frac{k(T_{12} - T_{16})(\Delta y/2)}{\Delta x} + \frac{k(T_{17} - T_{16})\Delta x}{\Delta y} + \frac{k(T_{19} - T_{16})(\Delta y/2)}{\Delta x} = 0$$

$$\text{Node 17: } \frac{k(T_{13} - T_{17})(\Delta y)}{\Delta x} + \frac{k(T_{16} - T_{17})\Delta x}{\Delta y} + \frac{k(T_{20} - T_{17})(\Delta y)}{\Delta x} + \frac{k(T_{18} - T_{17})(\Delta x)}{\Delta y} = 0$$

$$\text{Node 18: } \frac{k(T_{14} - T_{18})(\Delta y)}{\Delta x} + \frac{k(T_{17} - T_{18})\Delta x}{\Delta y} + h\Delta l(T_\infty - T_{18}) = 0$$

$$\text{Node 19: } \frac{k(T_{16} - T_{19})(\Delta y/2)}{\Delta x} + \frac{k(T_{20} - T_{19})\Delta x}{\Delta y} + \frac{k(T_{21} - T_{19})(\Delta y/2)}{\Delta x} = 0$$

$$\text{Node 20: } \frac{k(T_{17} - T_{20})(\Delta y)}{\Delta x} + \frac{k(T_{19} - T_{20})\Delta x}{\Delta y} + h\Delta l(T_\infty - T_{20}) = 0$$

$$\text{Node 21: } \frac{k(T_{19} - T_{21})(\Delta y/2)}{\Delta x} + h(\Delta l/2)(T_\infty - T_{21}) = 0$$

The fin heat rate per unit length is evaluated by considering conduction into its base expressed as

$$\dot{q}_f = 2 \left( k \frac{(T_1 - T_7)(\Delta y/2)}{\Delta x} + k \frac{(T_2 - T_8)(\Delta y)}{\Delta x} + k \frac{(T_3 - T_9)(\Delta y)}{\Delta x} + k \frac{(T_4 - T_{10})(\Delta y)}{\Delta x} + k \frac{(T_5 - T_{11})(\Delta y)}{\Delta x} \right)$$

where the factor of two is due to heat transfer in the bottom half of the fin. The result is  $\dot{q}_f = 109 \text{ W/m}$ . The fin efficiency is evaluated using Eq. 3.91 yielding

$$n_f = \frac{\dot{q}_f}{hA_f\theta_b} = \frac{\dot{q}_f}{h \left( 2\sqrt{L^2 + (t/2)^2} \right) \theta_b} = \frac{109 \text{ W/m}}{50 \text{ W/m}^2 \cdot \text{K} \left( 2\sqrt{(50 \times 10^{-3} \text{ m})^2 + (20 \times 10^{-3} \text{ m}/2)^2} \right) 30 \text{ K}} = 0.71 <$$

Continued...



### PROBLEM 4.66 (Cont.)

From Fig. 3.19 we find  $L_c = 50 \times 10^{-3} \text{ m}$ ,  $A_p = Lt/2 = (50 \times 10^{-3} \text{ m} \times 20 \times 10^{-3} \text{ m})/2 = 500 \times 10^{-6} \text{ m}^2$ .  
Therefore,

$$L_c^{3/2} \left( \frac{h}{kA_p} \right)^{1/2} = (50 \times 10^{-3} \text{ m})^{3/2} \times \left( \frac{50 \text{ W/m}^2 \cdot \text{K}}{25 \text{ W/m} \cdot \text{K} \times 500 \times 10^{-6} \text{ m}^2} \right)^{1/2} = 0.707$$

and  $n_f \approx 0.78$ . The comparison between the calculated value and the value from the figure is reasonable. The difference may be attributed to convective loss from the fin adjacent to the base that is not accounted for in the finite difference solution, as discussed in Comment 3 below, or more generally, to the relatively coarse nodal mesh.

**COMMENTS:** (1) The nodal temperatures are:

$T_6 = 50^\circ\text{C}$									
$T_5 = 50^\circ\text{C}$	$T_{11} = 47.57^\circ\text{C}$								
$T_4 = 50^\circ\text{C}$	$T_{10} = 47.58^\circ\text{C}$	$T_{15} = 45.28^\circ\text{C}$							
$T_3 = 50^\circ\text{C}$	$T_9 = 47.59^\circ\text{C}$	$T_{14} = 45.29^\circ\text{C}$	$T_{18} = 43.10^\circ\text{C}$						
$T_2 = 50^\circ\text{C}$	$T_8 = 47.60^\circ\text{C}$	$T_{13} = 45.30^\circ\text{C}$	$T_{17} = 43.11^\circ\text{C}$	$T_{20} = 41.03^\circ\text{C}$					
$T_1 = 50^\circ\text{C}$	$T_7 = 47.60^\circ\text{C}$	$T_{12} = 45.30^\circ\text{C}$	$T_{16} = 43.11^\circ\text{C}$	$T_{19} = 41.03^\circ\text{C}$	$T_{21} = 39.09^\circ\text{C}$				

Note the nearly uniform cross-sectional temperatures within the fin. Temperatures near the centerline are only slightly warmer than corresponding temperatures at a particular  $x$ -location nearer to the convectively-cooled fin surface. (2) The *IHT* code is listed below.

```
// Input Parameters
k = 25
Tinf = 20
Tbase = 50
delx = 0.01
dely = 0.002
h = 50
dell = sqrt(delx^2 + dely^2)

//Nodal Energy Balance Equations

//Node 1
T1 = Tbase
//Node 2
T2 = Tbase
//Node 3
T3 = Tbase
//Node 4
T4 = Tbase
//Node 5
T5 = Tbase
//Node 6
T6 = Tbase
//Node 7
k*(T1 - T7)*dely/2/delx + k*(T8 - T7)*delx/dely + k*(T12 - T7)*dely/2/delx = 0
//Node 8
k*(T2 - T8)*dely/delx + k*(T7 - T8)*delx/dely + k*(T13 - T8)*dely/delx + k*(T9 - T8)*delx/dely = 0
//Node 9
k*(T3 - T9)*dely/delx + k*(T8 - T9)*delx/dely + k*(T14 - T9)*dely/delx + k*(T10 - T9)*delx/dely = 0
//Node 10
k*(T4 - T10)*dely/delx + k*(T9 - T10)*delx/dely + k*(T15 - T10)*dely/delx + k*(T11 - T10)*delx/dely = 0
//Node 11
k*(T5 - T11)*dely/delx + k*(T10 - T11)*delx/dely + h*dell*(Tinf - T11) = 0
```

Continued...

## PROBLEM 4.66 (Cont.)

```

//Node 12
k*(T7 - T12)*dely/2/delx + k*(T13 - T12)*delx/dely + k*(T16 - T12)*dely/2/delx = 0
//Node 13
k*(T8 - T13)*dely/delx + k*(T12 - T13)*delx/dely + k*(T17 - T13)*dely/delx + k*(T14 - T13)*delx/dely = 0
//Node 14
k*(T9 - T14)*dely/delx + k*(T13 - T14)*delx/dely + k*(T18 - T14)*dely/delx + k*(T15 - T14)*delx/dely = 0
//Node 15
k*(T10 - T15)*dely/delx + k*(T14 - T15)*delx/dely + h*dell*(Tinf - T15) = 0
//Node 16
k*(T12 - T16)*dely/2/delx + k*(T17 - T16)*delx/dely + k*(T19 - T16)*dely/2/delx = 0
//Node 17
k*(T13 - T17)*dely/delx + k*(T16 - T17)*delx/dely + k*(T20 - T17)*dely/delx + k*(T18 - T17)*delx/dely = 0
//Node 18
k*(T14 - T18)*dely/delx + k*(T17 - T18)*delx/dely + h*dell*(Tinf - T18) = 0
//Node 19
k*(T16 - T19)*dely/2/delx + k*(T20 - T19)*delx/dely + k*(T21 - T19)*dely/2/delx = 0
//Node 20
k*(T17 - T20)*dely/delx + k*(T19 - T20)*delx/dely + h*dell*(Tinf - T20) = 0
//Node 21
k*(T19 - T21)*dely/2/delx + h*dell*(Tinf - T21)/2 = 0

//Fin Heat Transfer Rate

qfinhalf = k*(T1 - T7)*dely/2/delx + k*(T2 - T8)*dely/delx + k*(T3 - T9)*dely/delx + k*(T4 - T10)*dely/delx + k*(T5 -
T11)*dely/delx

qfin = 2*qfinhalf

```

(3) The finite difference equations do not account for convective losses from the fin in the exposed region of length  $\Delta l / 2$  adjacent to the root of the fin. If this convective loss is estimated to be

$$\dot{q}_{est} = 2(\Delta l / 2)h(T_6 - T_\infty) = 2 \times (10.198 \times 10^{-3} \text{ m}) / 2 \times 50 \frac{\text{W}}{\text{m}^2 \cdot \text{K}} \times (50^\circ\text{C} - 20^\circ\text{C}) = 15.3 \text{ W/m}$$

The fin heat transfer rate increases to  $\dot{q}_f = 109 \text{ W/m} + 15.3 \text{ W/m} = 124.3 \text{ W/m}$  and the fin efficiency increases to  $n_f = 0.81$ , slightly greater than the fin efficiency found from Fig. 3.19.

### PROBLEM 4.67

**KNOWN:** Rectangular air ducts having surfaces at 80°C in a concrete slab with an insulated bottom and upper surface maintained at 30°C.

**FIND:** Heat rate from each duct per unit length of duct,  $q'$ .

**SCHEMATIC:**

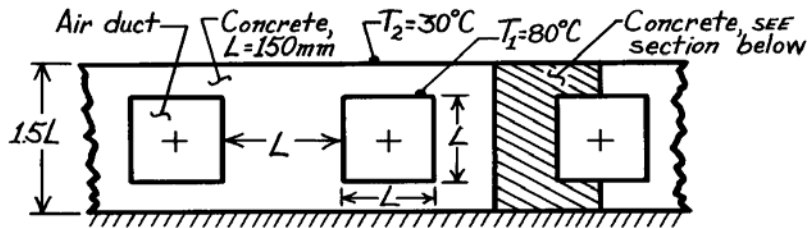

**ASSUMPTIONS:** (1) Steady-state conditions, (2) Two-dimensional conduction, (3) No internal volumetric generation, (4) Constant properties.

**PROPERTIES:** Concrete (given):  $k = 1.4 \text{ W/m}\cdot\text{K}$ .

**ANALYSIS:** Taking advantage of symmetry, the nodal network, using the suggested grid spacing

$$\Delta x = 2\Delta y = 37.50 \text{ mm}$$

$$\Delta y = 0.125L = 18.75 \text{ mm}$$

where  $L = 150 \text{ mm}$ , is shown in the sketch. To

evaluate the heat rate, we need the temperatures  $T_1$ ,

$T_2$ ,  $T_3$ ,  $T_4$ , and  $T_5$ . All the nodes may be treated as interior nodes (considering symmetry for those nodes on insulated boundaries), Eq. 4.29. Use matrix notation, Eq. 4.48,  $[A][T] = [C]$ , and perform the inversion.

The heat rate per unit length from the prescribed section of the duct follows from an energy balance on the nodes at the top isothermal surface.

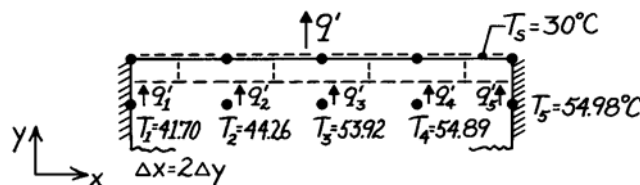
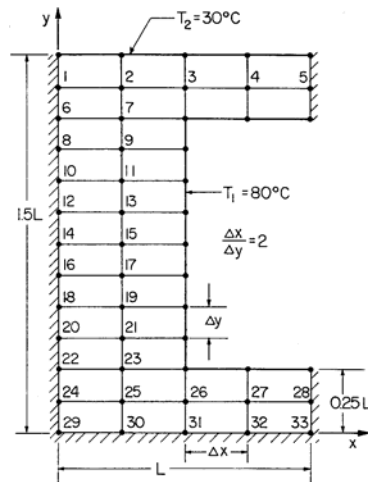

$$q' = q'_1 + q'_2 + q'_3 + q'_4 + q'_5$$

$$q' = k(\Delta x/2) \frac{T_1 - T_s}{\Delta y} + k \cdot \Delta x \frac{T_2 - T_s}{\Delta y} + k \cdot \Delta x \frac{T_3 - T_s}{\Delta y} + k \cdot \Delta x \frac{T_4 - T_s}{\Delta y} + k(\Delta x/2) \frac{T_5 - T_s}{\Delta y}$$

$$q' = k \left[ (T_1 - T_s) + 2(T_2 - T_s) + 2(T_3 - T_s) + 2(T_4 - T_s) + (T_5 - T_s) \right]$$

$$q' = 1.4 \text{ W/m}\cdot\text{K} \left[ (41.70 - 30) + 2(44.26 - 30) + 2(53.92 - 30) + 2(54.89 - 30) + (54.98 - 30) \right]$$

$$q' = 228 \text{ W/m}$$

Since the section analyzed represents one-half of the region about an air duct, the heat loss per unit length for each duct is,

$$q'_{\text{duct}} = 2xq' = 456 \text{ W/m}$$

<

Continued ...



### PROBLEM 4.68

**KNOWN:** Dimensions and operating conditions for a gas turbine blade with embedded channels.

**FIND:** Effect of applying a zirconia, thermal barrier coating.

**SCHEMATIC:**

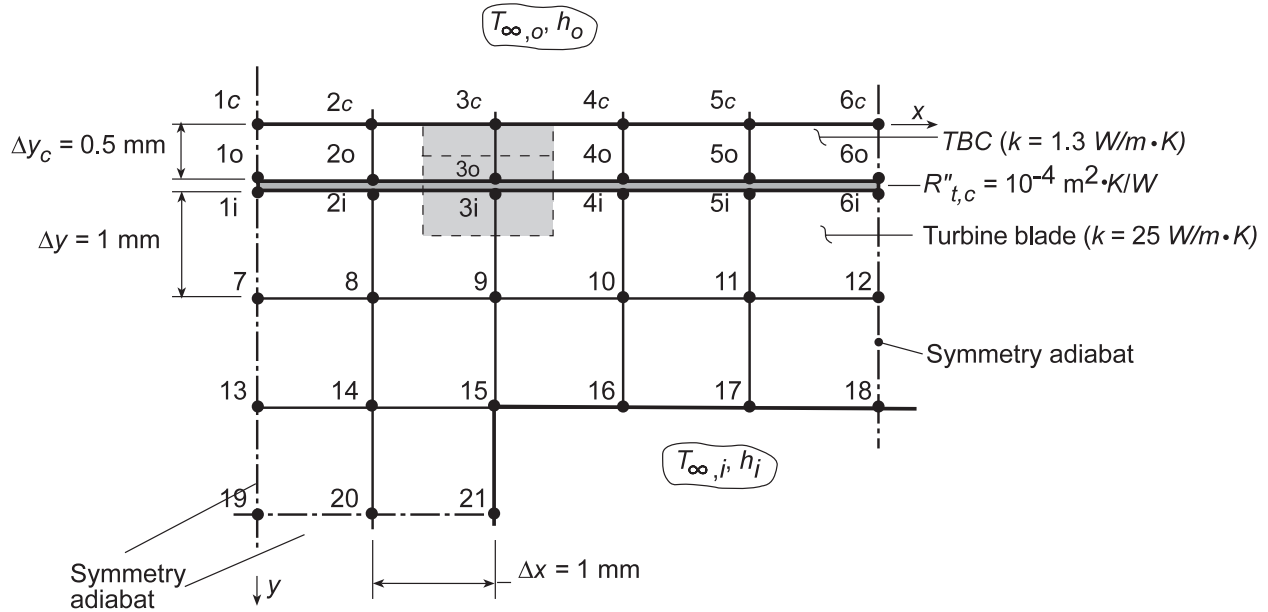

**ASSUMPTIONS:** (1) Steady-state, two-dimensional conduction, (2) Constant properties, (3) Negligible radiation.

**ANALYSIS:** Preserving the nodal network of Example 4.3 and adding surface nodes for the TBC, finite-difference equations previously developed for nodes 7 through 21 are still appropriate, while new equations must be developed for nodes 1c-6c, 1o-6o, and 1i-6i. Considering node 3c as an example, an energy balance yields

$$h_o \Delta x (T_{\infty,o} - T_{3c}) + \frac{k_c (\Delta y_c / 2)}{\Delta x} (T_{2c} - T_{3c}) + \frac{k_c (\Delta y_c / 2)}{\Delta x} (T_{4c} - T_{3c}) + \frac{k_c \Delta x}{\Delta y_c} (T_{3o} - T_{3c}) = 0$$

or, with  $\Delta x = 1 \text{ mm}$  and  $\Delta y_c = 0.5 \text{ mm}$ ,

$$0.25(T_{2c} + T_{4c}) + 2T_{3o} - \left( 2.5 + \frac{h_o \Delta x}{k_c} \right) T_{3c} = -\frac{h_o \Delta x}{k_c} T_{\infty,o}$$

Similar expressions may be obtained for the other 5 nodal points on the outer surface of the TBC.

Applying an energy balance to node 3o at the inner surface of the TBC, we obtain

$$\frac{k_c \Delta x}{\Delta y_c} (T_{3c} - T_{3o}) + \frac{k_c (\Delta y_c / 2)}{\Delta x} (T_{2o} - T_{3o}) + \frac{k_c (\Delta y_c / 2)}{\Delta x} (T_{4o} - T_{3o}) + \frac{\Delta x}{R''_{t,c}} (T_{3i} - T_{3o}) = 0$$

or,

$$2T_{3c} + 0.25(T_{2o} + T_{4o}) + \frac{\Delta x}{k_c R''_{t,c}} T_{3i} - \left( 2.5 + \frac{\Delta x}{k_c R''_{t,c}} \right) T_{3o} = 0$$

Similar expressions may be obtained for the remaining nodal points on the inner surface of the TBC (outer region of the contact resistance).

Continued...

### PROBLEM 4.68 (Cont.)

Applying an energy balance to node 3i at the outer surface of the turbine blade, we obtain

$$\frac{\Delta x}{R''_{t,c}}(T_{3o} - T_{3i}) + \frac{k(\Delta y/2)}{\Delta x}(T_{2i} - T_{3i}) + \frac{k(\Delta y/2)}{\Delta x}(T_{4i} - T_{3i}) + \frac{k\Delta x}{\Delta y}(T_9 - T_{3i}) = 0$$

or,

$$\frac{\Delta x}{kR''_{t,c}}T_{3o} + 0.5(T_{2,i} + T_{4,i}) + T_9 - \left(2 + \frac{\Delta x}{kR''_{t,c}}\right)T_{3i} = 0$$

Similar expressions may be obtained for the remaining nodal points on the inner region of the contact resistance.

The 33 finite-difference equations were entered into the workspace of IHT from the keyboard, and for  $h_o = 1000 \text{ W/m}^2\cdot\text{K}$ ,  $T_{\infty,o} = 1700 \text{ K}$ ,  $h_i = 200 \text{ W/m}^2\cdot\text{K}$  and  $T_{\infty,i} = 400 \text{ K}$ , the following temperature field was obtained, where coordinate (x,y) locations are in mm and temperatures are in °C.

y\x	0	1	2	3	4	5
0	1536	1535	1534	1533	1533	1532
0.5	1473	1472	1471	1469	1468	1468
0.5	1456	1456	1454	1452	1451	1451
1.5	1450	1450	1447	1446	1444	1444
2.5	1446	1445	1441	1438	1437	1436
3.5	1445	1443	1438	0	0	0

Note the significant reduction in the turbine blade temperature, as, for example, from a surface temperature of  $T_1 = 1526 \text{ K}$  without the TBC to  $T_{1i} = 1456 \text{ K}$  with the coating. Hence, the coating is serving its intended purpose.

**COMMENTS:** (1) Significant additional benefits may still be realized by increasing  $h_i$ . (2) The foregoing solution may be used to determine the temperature field without the TBC by setting  $k_c \rightarrow \infty$  and  $R''_{t,c} \rightarrow 0$ .

### PROBLEM 4.69

**KNOWN:** Dimensions of long cylinder, thickness of metal sheathing, volumetric generation rate within the sheathing, thermal conductivity of sheathing and convection heat transfer coefficient dependence upon angle  $\theta$ .

**FIND:** (a) Temperature distribution within the thin sheathing neglecting  $\theta$ -direction conduction heat transfer, (b) temperature distribution in the sheathing accounting for  $\theta$ -direction conduction heat transfer in the metal.

**SCHEMATIC:**

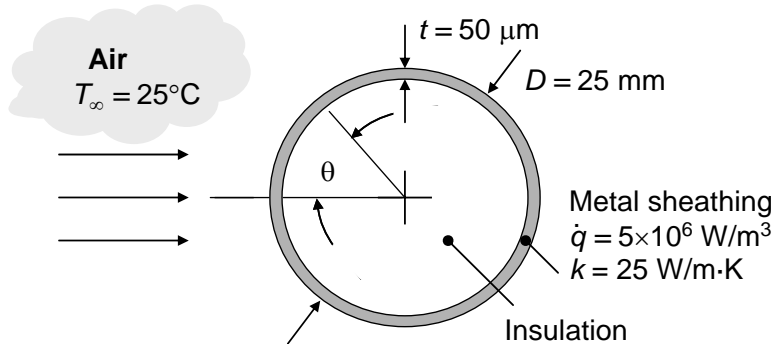

**ASSUMPTIONS:** (1) Steady-state conditions, (2) Constant properties, (3) Uniform internal generation, (4) Metal sheathing is very thin relative to cylinder diameter, (5) One-dimensional conduction, (6) Negligible radiation.

**ANALYSIS:** (a) Neglecting conduction in the  $\theta$ -direction in the sheathing, an energy balance at any  $\theta$  location yields

$$\dot{q}t = h(\theta)(T_s - T_\infty) \quad \text{or} \quad T_s = T_\infty + \dot{q}t/h(\theta) \quad \text{and}$$

$$h(\theta) = 26 + 0.637\theta - 8.92\theta^2 \quad \text{for} \quad 0 \leq \theta < \pi/2; \quad h(\theta) = 5 \quad \text{for} \quad \pi/2 \leq \theta \leq \pi$$

These equations may be solved to yield the temperature distribution that is plotted on the next page where  $x = \theta D/2$ .

(b) Since the sheathing is thin relative to the cylinder diameter, we may evaluate one-dimensional conduction in the  $x$ -direction using the Cartesian coordinate system. The finite difference equations are derived by combining expressions for heat fluxes based upon Fourier's law and Newton's law of cooling, along with conservation of energy for each control volume within the discretized domain. Application of conservation of energy for each control volume yields the expression  $\dot{E}_{in} + \dot{E}_g = 0$ . The discretized domain is shown below.

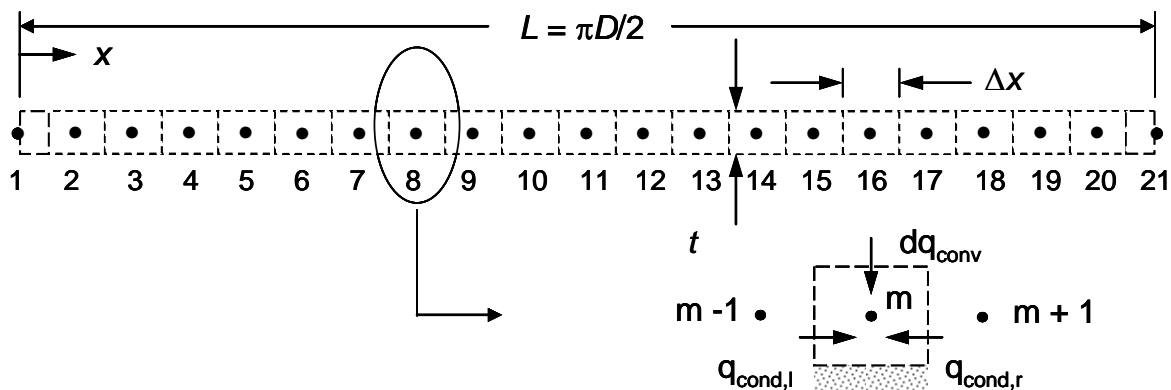

Continued...

### PROBLEM 4.69 (Cont.)

The finite difference equations are as follows.

$$\text{Node 1: } k \frac{(T_2 - T_1)}{\Delta x} t + h(\Delta x/2)(T_\infty - T_1) + \dot{q}(\Delta x/2)t = 0$$

$$\text{Nodes 2 - 20: } k \frac{(T_{m-1} - T_m)}{\Delta x} t + k \frac{(T_{m+1} - T_m)}{\Delta x} t + h(\Delta x)(T_\infty - T_m) + \dot{q}(\Delta x)t = 0$$

$$\text{Node 21: } k \frac{(T_{20} - T_{21})}{\Delta x} t + h(\Delta x/2)(T_\infty - T_{21}) + \dot{q}(\Delta x/2)t = 0$$

The temperature distribution is plotted below.

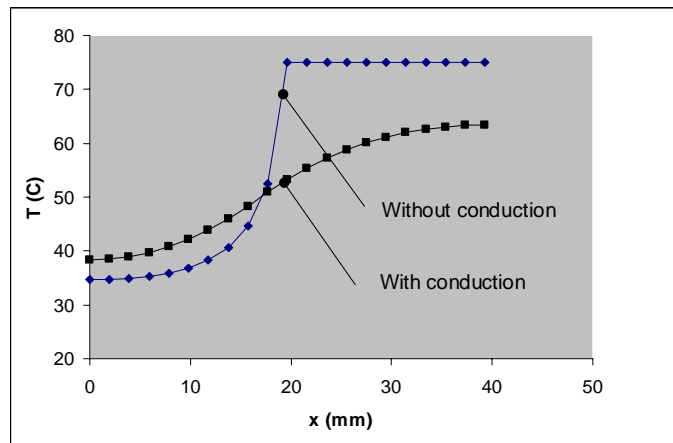

**COMMENTS:** (1) Conduction in the  $\theta$ -direction within the sheathing smears the temperature distribution, increasing the low temperatures on the upstream half of the cylinder and lowering the temperatures on the downstream half of the cylinder. (2) The *IHT* code is listed below.

```

qdot = 5*10^6 //W/m^3
t = 50*10^-6 //m
Tinf = 25 + 273 //K
k = 25 //W/m.K
D = 25/1000 //m
L = pi*D/2 //m
dx = L/20 //m

h1 = 26 //W/m^2.K
h2 = 25.88
h3 = 25.32
h4 = 24.32
h5 = 22.88
h6 = 21.00
h7 = 18.68
h8 = 15.92
h9 = 12.71
h10 = 9.07
h11 = 5
h12 = 5
h13 = 5
h14 = 5
h15 = 5
h16 = 5
h17 = 5
h18 = 5
    
```

Continued...



## PROBLEM 4.69 (Cont.)

$$h_{19} = 5$$

$$h_{20} = 5$$

$$h_{21} = 5$$

//Node 1

$$k(T_2 - T_1)/dx + h_1(dx/2)(T_{inf} - T_1) + qdot \cdot dx/2 = 0$$

//Node 2

$$k(T_1 - T_2)/dx + k(T_3 - T_2)/dx + h_2 \cdot dx(T_{inf} - T_2) + qdot \cdot dx \cdot t = 0$$

//Node 3

$$k(T_2 - T_3)/dx + k(T_4 - T_3)/dx + h_3 \cdot dx(T_{inf} - T_3) + qdot \cdot dx \cdot t = 0$$

//Node 4

$$k(T_3 - T_4)/dx + k(T_5 - T_4)/dx + h_4 \cdot dx(T_{inf} - T_4) + qdot \cdot dx \cdot t = 0$$

//Node 5

$$k(T_4 - T_5)/dx + k(T_6 - T_5)/dx + h_5 \cdot dx(T_{inf} - T_5) + qdot \cdot dx \cdot t = 0$$

//Node 6

$$k(T_5 - T_6)/dx + k(T_7 - T_6)/dx + h_6 \cdot dx(T_{inf} - T_6) + qdot \cdot dx \cdot t = 0$$

//Node 7

$$k(T_6 - T_7)/dx + k(T_8 - T_7)/dx + h_7 \cdot dx(T_{inf} - T_7) + qdot \cdot dx \cdot t = 0$$

//Node 8

$$k(T_7 - T_8)/dx + k(T_9 - T_8)/dx + h_8 \cdot dx(T_{inf} - T_8) + qdot \cdot dx \cdot t = 0$$

//Node 9

$$k(T_8 - T_9)/dx + k(T_{10} - T_9)/dx + h_9 \cdot dx(T_{inf} - T_9) + qdot \cdot dx \cdot t = 0$$

//Node 10

$$k(T_9 - T_{10})/dx + k(T_{11} - T_{10})/dx + h_{10} \cdot dx(T_{inf} - T_{10}) + qdot \cdot dx \cdot t = 0$$

//Node 11

$$k(T_{10} - T_{11})/dx + k(T_{12} - T_{11})/dx + h_{11} \cdot dx(T_{inf} - T_{11}) + qdot \cdot dx \cdot t = 0$$

//Node 12

$$k(T_{11} - T_{12})/dx + k(T_{13} - T_{12})/dx + h_{12} \cdot dx(T_{inf} - T_{12}) + qdot \cdot dx \cdot t = 0$$

//Node 13

$$k(T_{12} - T_{13})/dx + k(T_{14} - T_{13})/dx + h_{13} \cdot dx(T_{inf} - T_{13}) + qdot \cdot dx \cdot t = 0$$

//Node 14

$$k(T_{13} - T_{14})/dx + k(T_{15} - T_{14})/dx + h_{14} \cdot dx(T_{inf} - T_{14}) + qdot \cdot dx \cdot t = 0$$

//Node 15

$$k(T_{14} - T_{15})/dx + k(T_{16} - T_{15})/dx + h_{15} \cdot dx(T_{inf} - T_{15}) + qdot \cdot dx \cdot t = 0$$

//Node 16

$$k(T_{15} - T_{16})/dx + k(T_{17} - T_{16})/dx + h_{16} \cdot dx(T_{inf} - T_{16}) + qdot \cdot dx \cdot t = 0$$

//Node 17

$$k(T_{16} - T_{17})/dx + k(T_{18} - T_{17})/dx + h_{17} \cdot dx(T_{inf} - T_{17}) + qdot \cdot dx \cdot t = 0$$

//Node 18

$$k(T_{17} - T_{18})/dx + k(T_{19} - T_{18})/dx + h_{18} \cdot dx(T_{inf} - T_{18}) + qdot \cdot dx \cdot t = 0$$

//Node 19

$$k(T_{18} - T_{19})/dx + k(T_{20} - T_{19})/dx + h_{19} \cdot dx(T_{inf} - T_{19}) + qdot \cdot dx \cdot t = 0$$

//Node 20

$$k(T_{19} - T_{20})/dx + k(T_{21} - T_{20})/dx + h_{20} \cdot dx(T_{inf} - T_{20}) + qdot \cdot dx \cdot t = 0$$

//Node 21

$$k(T_{20} - T_{21})/dx + h_{21}(dx/2)(T_{inf} - T_{21}) + qdot \cdot dx/2 = 0$$

### PROBLEM 4.70

**KNOWN:** Diameter of long cylinder, thickness of metal sheathing, volumetric generation rate within the sheathing, thermal conductivity of sheathing and convection heat transfer coefficient dependence upon angle  $\theta$ . Emissivity of the sheathing.

**FIND:** (a) Temperature distribution within the thin sheathing accounting for convection, conduction in the sheathing, and radiation exchange with the surroundings.

**SCHEMATIC:**

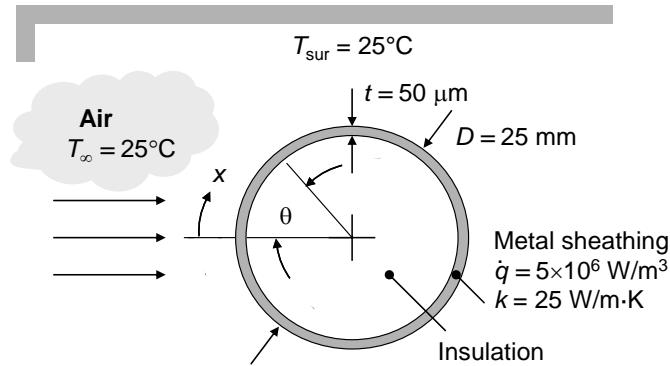

**ASSUMPTIONS:** (1) Steady-state conditions, (2) Constant properties, (3) Uniform internal generation, (4) Metal sheathing is very thin relative to cylinder diameter, (5) One-dimensional conduction, (6) Large surroundings.

**ANALYSIS:** From Problem 4.69,

$$h(\theta) = 26 + 0.637\theta - 8.92\theta^2 \text{ for } 0 \leq \theta < \pi/2; \quad h(\theta) = 5 \text{ for } \pi/2 \leq \theta \leq \pi$$

Since the sheathing is thin relative to the cylinder diameter, we may evaluate one-dimensional conduction in the  $x$ -direction using the Cartesian coordinate system. The finite difference equations are derived by combining expressions for heat fluxes determined from Fourier's law, Newton's law of cooling, and Eq. 1.7 along with conservation of energy for each control volume within the discretized domain. Application of conservation of energy for each control volume yields the expression  $\dot{E}_{in} + \dot{E}_g = 0$ . The discretized domain is shown below.

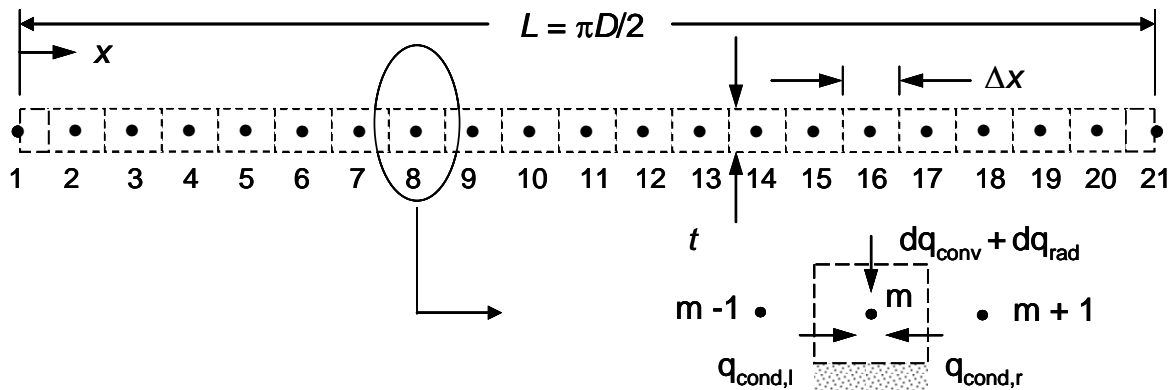

Energy balances for the control volumes are as follows.

Node 1: 
$$k \frac{(T_2 - T_1)}{\Delta x} t + h(\Delta x/2)(T_\infty - T_1) + \varepsilon\sigma(\Delta x/2)(T_{sur}^4 - T_1^4) + \dot{q}(\Delta x/2)t = 0$$

Continued...

### PROBLEM 4.70 (Cont.)

Nodes 2 - 20:  $k \frac{(T_{m-1} - T_m)}{\Delta x} t + k \frac{(T_{m+1} - T_m)}{\Delta x} t + h(\Delta x)(T_\infty - T_m) + \varepsilon\sigma(\Delta x)(T_{\text{sur}}^4 - T_m^4) + \dot{q}(\Delta x)t = 0$

Node 21:  $k \frac{(T_{20} - T_{21})}{\Delta x} t + h(\Delta x/2)(T_\infty - T_{21}) + \varepsilon\sigma(\Delta x/2)(T_{\text{sur}}^4 - T_{21}^4) + \dot{q}(\Delta x/2)t = 0$

The temperature distribution is plotted below.

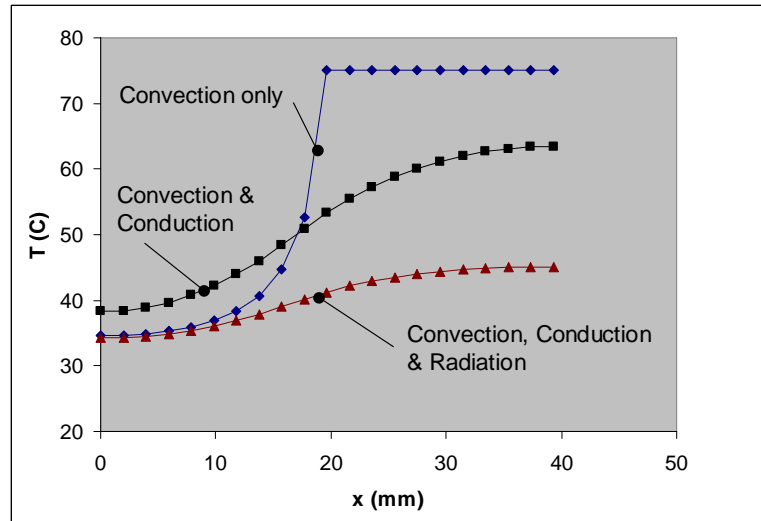

**COMMENTS:** (1) Inclusion of radiation in the analysis shows that the resulting temperatures are reduced overall, as expected. The effects of conduction and radiation on local temperatures are comparable. (2) The *IHT* code is listed below.

```

D = 25/1000           //m
L = pi*D/2           //m
dx = L/20            //m

qdot = 5*10^6        //W/m^3
t = 50*10^(-6)       //m
Tinf = 25 + 273      //K
k = 25               //W/m-K
eps = 0.98           //unitless
sigma=5.67*10^(-8)   //Stefan-Boltzmann constant, W/m^2-K^4
Tsur = Tinf          //K

h1 = 26              //W/m^2-K
h2 = 25.88
h3 = 25.32
h4 = 24.32
h5 = 22.88
h6 = 21.00
h7 = 18.68
h8 = 15.92
h9 = 12.71
h10 = 9.07
h11 = 5
h12 = 5
h13 = 5
h14 = 5
h15 = 5
h16 = 5
h17 = 5
    
```

Continued...

## PROBLEM 4.70 (Cont.)

$$h_{18} = 5$$

$$h_{19} = 5$$

$$h_{20} = 5$$

$$h_{21} = 5$$

//Node 1

$$k*(T2 - T1)*t/dx + h1*(dx/2)*(Tinf - T1) + eps*sigma*(dx/2)*(Tsur^4 - T1^4) + qdot*dx*t/2 = 0$$

//Node 2

$$k*(T1 - T2)*t/dx + k*(T3 - T2)*t/dx + h2*dx*(Tinf - T2) + eps*sigma*dx*(Tsur^4 - T2^4) + qdot*dx*t = 0$$

//Node 3

$$k*(T2 - T3)*t/dx + k*(T4 - T3)*t/dx + h3*dx*(Tinf - T3) + eps*sigma*dx*(Tsur^4 - T3^4) + qdot*dx*t = 0$$

//Node 4

$$k*(T3 - T4)*t/dx + k*(T5 - T4)*t/dx + h4*dx*(Tinf - T4) + eps*sigma*dx*(Tsur^4 - T4^4) + qdot*dx*t = 0$$

//Node 5

$$k*(T4 - T5)*t/dx + k*(T6 - T5)*t/dx + h5*dx*(Tinf - T5) + eps*sigma*dx*(Tsur^4 - T5^4) + qdot*dx*t = 0$$

//Node 6

$$k*(T5 - T6)*t/dx + k*(T7 - T6)*t/dx + h6*dx*(Tinf - T6) + eps*sigma*dx*(Tsur^4 - T6^4) + qdot*dx*t = 0$$

//Node 7

$$k*(T6 - T7)*t/dx + k*(T8 - T7)*t/dx + h7*dx*(Tinf - T7) + eps*sigma*dx*(Tsur^4 - T7^4) + qdot*dx*t = 0$$

//Node 8

$$k*(T7 - T8)*t/dx + k*(T9 - T8)*t/dx + h8*dx*(Tinf - T8) + eps*sigma*dx*(Tsur^4 - T8^4) + qdot*dx*t = 0$$

//Node 9

$$k*(T8 - T9)*t/dx + k*(T10 - T9)*t/dx + h9*dx*(Tinf - T9) + eps*sigma*dx*(Tsur^4 - T9^4) + qdot*dx*t = 0$$

//Node 10

$$k*(T9 - T10)*t/dx + k*(T11 - T10)*t/dx + h10*dx*(Tinf - T10) + eps*sigma*dx*(Tsur^4 - T10^4) + qdot*dx*t = 0$$

//Node 11

$$k*(T10 - T11)*t/dx + k*(T12 - T11)*t/dx + h11*dx*(Tinf - T11) + eps*sigma*dx*(Tsur^4 - T11^4) + qdot*dx*t = 0$$

//Node 12

$$k*(T11 - T12)*t/dx + k*(T13 - T12)*t/dx + h12*dx*(Tinf - T12) + eps*sigma*dx*(Tsur^4 - T12^4) + qdot*dx*t = 0$$

//Node 13

$$k*(T12 - T13)*t/dx + k*(T14 - T13)*t/dx + h13*dx*(Tinf - T13) + eps*sigma*dx*(Tsur^4 - T13^4) + qdot*dx*t = 0$$

//Node 14

$$k*(T13 - T14)*t/dx + k*(T15 - T14)*t/dx + h14*dx*(Tinf - T14) + eps*sigma*dx*(Tsur^4 - T14^4) + qdot*dx*t = 0$$

//Node 15

$$k*(T14 - T15)*t/dx + k*(T16 - T15)*t/dx + h15*dx*(Tinf - T15) + eps*sigma*dx*(Tsur^4 - T15^4) + qdot*dx*t = 0$$

//Node 16

$$k*(T15 - T16)*t/dx + k*(T17 - T16)*t/dx + h16*dx*(Tinf - T16) + eps*sigma*dx*(Tsur^4 - T16^4) + qdot*dx*t = 0$$

//Node 17

$$k*(T16 - T17)*t/dx + k*(T18 - T17)*t/dx + h17*dx*(Tinf - T17) + eps*sigma*dx*(Tsur^4 - T17^4) + qdot*dx*t = 0$$

//Node 18

$$k*(T17 - T18)*t/dx + k*(T19 - T18)*t/dx + h18*dx*(Tinf - T18) + eps*sigma*dx*(Tsur^4 - T18^4) + qdot*dx*t = 0$$

//Node 19

$$k*(T18 - T19)*t/dx + k*(T20 - T19)*t/dx + h19*dx*(Tinf - T19) + eps*sigma*dx*(Tsur^4 - T19^4) + qdot*dx*t = 0$$

//Node 20

$$k*(T19 - T20)*t/dx + k*(T21 - T20)*t/dx + h20*dx*(Tinf - T20) + eps*sigma*dx*(Tsur^4 - T20^4) + qdot*dx*t = 0$$

//Node 21

$$k*(T20 - T21)*t/dx + h21*(dx/2)*(Tinf - T21) + eps*sigma*(dx/2)*(Tsur^4 - T21^4) + qdot*dx*t/2 = 0$$

## PROBLEM 4.71

**KNOWN:** Geometry of long airfoil shape, thickness of metal sheathing, volumetric generation rate within the sheathing, thermal conductivity of sheathing, emissivity of the sheathing, and measured temperatures at discrete locations.

**FIND:** Local convection coefficient at discrete locations accounting for conduction along the sheathing and radiation. Determine effects of conduction and radiation on the calculated convection heat transfer coefficients.

**SCHEMATIC:**

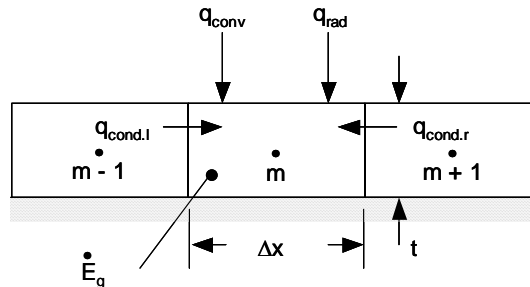
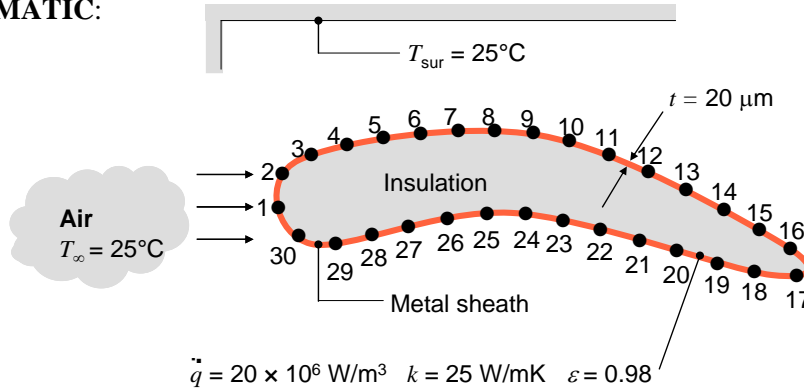

**ASSUMPTIONS:** (1) Steady-state conditions, (2) Constant properties, (3) Uniform internal generation, (4) Metal sheathing is very thin relative to cylinder diameter, (5) One-dimensional conduction, (6) Large surroundings.

**ANALYSIS:** We apply Newton's law of cooling, Fourier's law and Eq. 1.7 to a general control volume about the thin sheathing to find the following general finite-difference formula.

$$\dot{q}'_{\text{cond},l} + \dot{q}'_{\text{cond},r} + \dot{q}'_{\text{conv}} + \dot{q}'_{\text{rad}} + \dot{E}'_g = 0$$

or

$$k \frac{(T_{m-1} - T_m)}{\Delta x} t + k \frac{(T_{m+1} - T_m)}{\Delta x} t + h_m (\Delta x) (T_\infty - T_m) + \epsilon \sigma (\Delta x) (T_{\text{sur}}^4 - T_m^4) + \dot{q} (\Delta x) t = 0$$

Recognizing that for  $m = 1$ ,  $m - 1 = 30$ , we may substitute values of  $T_{m-1}$ ,  $T_m$ , and  $T_{m+1}$  and  $\Delta x = 2$  mm into the preceding formula and solve for  $h_m$ . The results for case A (inclusion of convection, conduction and radiation), case B (inclusion of convection and conduction only) and case C (inclusion of convection only) are tabulated below.

Continued...

**PROBLEM 4.71 (Cont.)**

$m$	$T_m$ (°C)	$h_{m,A}$ (W/m <sup>2</sup> ·K)	$h_{m,B}$ (W/m <sup>2</sup> ·K)	$h_{m,C}$ (W/m <sup>2</sup> ·K)
1	27.77	162.8	<u>168.8</u>	<i>144.4</i>
2	27.67	150.4	<u>156.4</u>	<i>149.8</i>
3	27.71	<i>145.3</i>	<u>151.3</u>	147.6
4	27.83	<i>140.2</i>	<u>146.2</u>	141.3
5	28.06	132.1	<u>138.1</u>	<i>130.7</i>
6	28.47	<i>112.9</i>	<u>118.9</u>	115.3
7	28.98	<i>100.1</i>	<u>106.2</u>	100.5
8	29.67	87.66	<u>93.68</u>	85.65
9	30.66	76.32	<u>82.38</u>	<i>70.67</i>
10	32.18	59.88	<u>65.98</u>	<i>55.71</i>
11	34.29	<i>42.01</i>	<u>48.17</u>	43.06
12	36.78	<i>27.93</i>	<u>34.17</u>	33.96
13	39.29	<i>19.14</i>	25.45	<u>27.99</u>
14	41.51	9.89	16.28	<u>24.23</u>
15	42.68	9.06	15.48	<u>22.62</u>
16	42.84	<i>4.01</i>	10.44	<u>22.42</u>
17	41.29	3.98	10.36	<u>24.55</u>
18	37.89	<i>24.95</i>	<u>31.23</u>	31.03
19	34.51	52.06	<u>58.23</u>	<i>42.06</i>
20	32.36	63.87	<u>69.97</u>	<i>54.35</i>
21	31.13	74.28	<u>80.34</u>	<i>65.25</i>
22	30.64	74.84	<u>80.90</u>	<i>70.92</i>
23	30.60	<i>70.08</i>	<u>76.12</u>	71.43
24	30.77	<i>68.04</i>	74.09	69.32
25	31.16	58.26	64.33	<u>64.94</u>
26	31.52	<i>54.70</i>	60.77	<u>61.35</u>
27	31.85	<i>40.08</i>	46.17	<u>58.39</u>
28	31.51	<i>31.17</i>	37.25	<u>61.44</u>
29	29.91	<i>78.24</i>	<u>84.27</u>	81.47
30	28.42	141.7	<u>147.7</u>	<i>117.0</i>

Note: Maximum predicted values are underlined, while minimum predicted values are *italicized*.

**COMMENTS:** (1) The heat transfer coefficient distribution is non-uniform. Such non-uniformity is typical of situations involving convection around complex geometries. The largest heat transfer coefficients exist at the leading edge of the object, while the smallest values of  $h$  are near the trailing edge. (2) Differences in the measured values of the heat transfer coefficient evolve when different analyses are used to interpret the measured temperatures. (3) Inclusion of radiation in Analysis B always results in lower heat transfer coefficients (relative to Analysis A) since the object is hot relative to the large surroundings.

### PROBLEM 4.72

**KNOWN:** Thin metallic foil of thickness,  $t$ , whose edges are thermally coupled to a sink at temperature  $T_{sink}$  is exposed on the top surface to an ion beam heat flux,  $q_s''$ , and experiences radiation exchange with the vacuum enclosure walls at  $T_{sur}$ .

**FIND:** Temperature distribution across the foil.

**SCHEMATIC:**

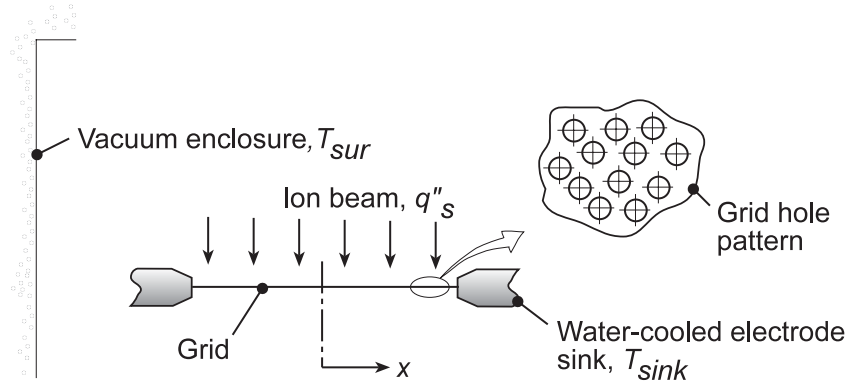

**ASSUMPTIONS:** (1) One-dimensional, steady-state conduction in the foil, (2) Constant properties, (3) Upper and lower surfaces of foil experience radiation exchange, (4) Foil is of unit length normal to the page.

**ANALYSIS:** The 10-node network representing the foil is shown below.

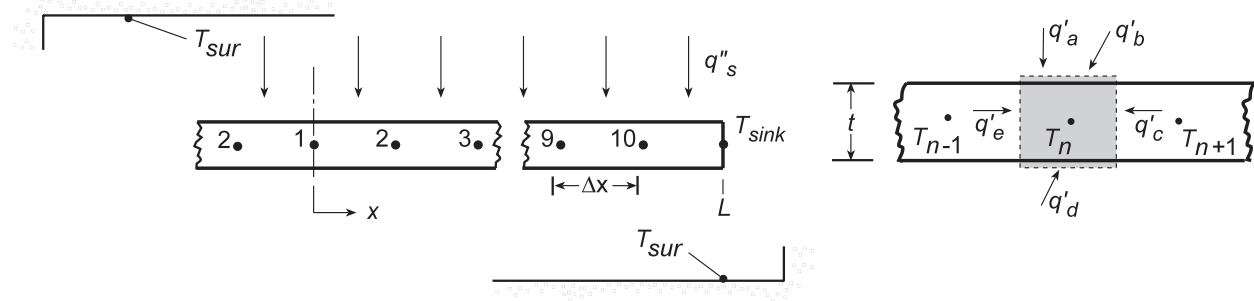

From an energy balance on node  $n$ ,  $\dot{E}_{in} - \dot{E}_{out} = 0$ , for a unit depth,

$$q'_a + q'_b + q'_c + q'_d + q'_e = 0$$

$$q_s'' \Delta x + h_{r,n} \Delta x (T_{sur} - T_n) + k(t)(T_{n+1} - T_n) / \Delta x + h_{r,n} \Delta x (T_{sur} - T_n) + k(t)(T_{n-1} - T_n) / \Delta x = 0 \quad (1)$$

where the linearized radiation coefficient for node  $n$  is

$$h_{r,n} = \varepsilon \sigma (T_{sur} + T_n) (T_{sur}^2 + T_n^2) \quad (2)$$

Solving Eq. (1) for  $T_n$  find,

$$T_n = \left[ (T_{n+1} + T_{n-1}) + \left( 2h_{r,n} \Delta x^2 / kt \right) T_{sur} + \left( \Delta x^2 / kt \right) q_s'' \right] / \left[ \left( h_{r,n} \Delta x^2 / kt \right) + 2 \right] \quad (3)$$

which, considering symmetry, applies also to node 1. Using IHT for Eqs. (3) and (2), the set of finite-difference equations was solved for the temperature distribution (K):

$T_1$	$T_2$	$T_3$	$T_4$	$T_5$	$T_6$	$T_7$	$T_8$	$T_9$	$T_{10}$
374.1	374.0	373.5	372.5	370.9	368.2	363.7	356.6	345.3	327.4

Continued...

## PROBLEM 4.72 (Cont.)

**COMMENTS:** (1) If the temperature gradients were excessive across the foil, it would wrinkle; most likely since its edges are constrained, the foil will bow.

(2) The IHT workspace for the finite-difference analysis follows:

**// The nodal equations:**

$$T1 = ( (T2 + T2) + A1 * Tsur + B * q''s ) / ( A1 + 2)$$

$$A1 = 2 * hr1 * \text{deltax}^2 / (k * t)$$

$$hr1 = \text{eps} * \text{sigma} * (Tsur + T1) * (Tsur^2 + T1^2)$$

$$\text{sigma} = 5.67e-8$$

$$B = \text{deltax}^2 / (k * t)$$

$$T2 = ( (T1 + T3) + A2 * Tsur + B * q''s ) / ( A2 + 2)$$

$$A2 = 2 * hr2 * \text{deltax}^2 / (k * t)$$

$$hr2 = \text{eps} * \text{sigma} * (Tsur + T2) * (Tsur^2 + T2^2)$$

$$T3 = ( (T2 + T4) + A3 * Tsur + B * q''s ) / ( A3 + 2)$$

$$A3 = 2 * hr3 * \text{deltax}^2 / (k * t)$$

$$hr3 = \text{eps} * \text{sigma} * (Tsur + T3) * (Tsur^2 + T3^2)$$

$$T4 = ( (T3 + T5) + A4 * Tsur + B * q''s ) / ( A4 + 2)$$

$$A4 = 2 * hr4 * \text{deltax}^2 / (k * t)$$

$$hr4 = \text{eps} * \text{sigma} * (Tsur + T4) * (Tsur^2 + T4^2)$$

$$T5 = ( (T4 + T6) + A5 * Tsur + B * q''s ) / ( A5 + 2)$$

$$A5 = 2 * hr5 * \text{deltax}^2 / (k * t)$$

$$hr5 = \text{eps} * \text{sigma} * (Tsur + T5) * (Tsur^2 + T5^2)$$

$$T6 = ( (T5 + T7) + A6 * Tsur + B * q''s ) / ( A6 + 2)$$

$$A6 = 2 * hr6 * \text{deltax}^2 / (k * t)$$

$$hr6 = \text{eps} * \text{sigma} * (Tsur + T6) * (Tsur^2 + T6^2)$$

$$T7 = ( (T6 + T8) + A7 * Tsur + B * q''s ) / ( A7 + 2)$$

$$A7 = 2 * hr7 * \text{deltax}^2 / (k * t)$$

$$hr7 = \text{eps} * \text{sigma} * (Tsur + T7) * (Tsur^2 + T7^2)$$

$$T8 = ( (T7 + T9) + A8 * Tsur + B * q''s ) / ( A8 + 2)$$

$$A8 = 2 * hr8 * \text{deltax}^2 / (k * t)$$

$$hr8 = \text{eps} * \text{sigma} * (Tsur + T8) * (Tsur^2 + T8^2)$$

$$T9 = ( (T8 + T10) + A9 * Tsur + B * q''s ) / ( A9 + 2)$$

$$A9 = 2 * hr9 * \text{deltax}^2 / (k * t)$$

$$hr9 = \text{eps} * \text{sigma} * (Tsur + T9) * (Tsur^2 + T9^2)$$

$$T10 = ( (T9 + Tsink) + A10 * Tsur + B * q''s ) / ( A10 + 2)$$

$$A10 = 2 * hr10 * \text{deltax}^2 / (k * t)$$

$$hr10 = \text{eps} * \text{sigma} * (Tsur + T10) * (Tsur^2 + T10^2)$$

**// Assigned variables**

$$\text{deltax} = L / 10$$

// Spatial increment, m

$$L = 0.150$$

// Foil length, m

$$t = 0.00025$$

// Foil thickness, m

$$\text{eps} = 0.45$$

// Emissivity

$$Tsur = 300$$

// Surroundings temperature, K

$$k = 40$$

// Foil thermal conductivity, W/m.K

$$Tsink = 300$$

// Sink temperature, K

$$q''s = 600$$

// Ion beam heat flux, W/m^2

**/\* Data Browser results: Temperature distribution (K) and linearized radiation coefficients (W/m^2.K):**

T1	T2	T3	T4	T5	T6	T7	T8	T9	T10
374.1	374	373.5	372.5	370.9	368.2	363.7	356.6	345.3	327.4
hr1	hr2	hr3	hr4	hr5	hr6	hr7	hr8	hr9	hr10
3.956	3.953	3.943	3.926	3.895	3.845	3.765	3.639	3.444	3.157 *



### PROBLEM 4.73

**KNOWN:** Bar of rectangular cross-section subjected to prescribed boundary conditions.

**FIND:** Using a numerical technique with a grid spacing of 0.1m, determine the temperature distribution and the heat transfer rate from the bar to the fluid.

**SCHEMATIC:**

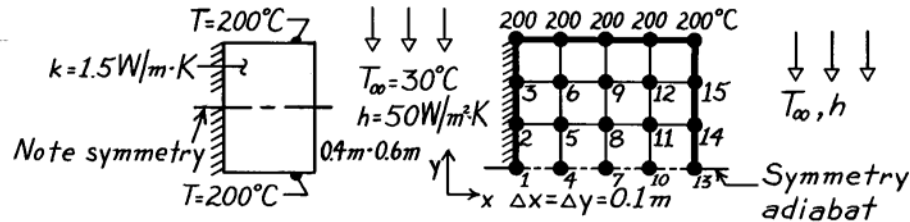

**ASSUMPTIONS:** (1) Steady-state conditions, (2) Two-dimensional conduction, (3) Constant properties.

**ANALYSIS:** The nodal network has  $\Delta x = \Delta y = 0.1\text{m}$ . Note the adiabat corresponding to system symmetry. The finite-difference equations for each node can be written using either Eq. 4.29, for interior nodes, or Eq. 4.42, for a plane surface with convection. In the case of adiabatic surfaces, Eq. 4.42 is used with  $h = 0$ . Note that

$$\frac{h\Delta x}{k} = \frac{50\text{W/m}^2 \cdot \text{K} \times 0.1\text{m}}{1.5\text{W/m} \cdot \text{K}} = 3.333.$$

Node	Finite-Difference Equations
1	$-4T_1 + 2T_2 + 2T_4 = 0$
2	$-4T_2 + T_1 + T_3 + 2T_5 = 0$
3	$-4T_3 + 200 + 2T_6 + T_2 = 0$
4	$-4T_4 + T_1 + 2T_5 + T_7 = 0$
5	$-4T_5 + T_2 + T_6 + T_8 + T_4 = 0$
6	$-4T_6 + T_5 + T_3 + 200 + T_9 = 0$
7	$-4T_7 + T_4 + 2T_8 + T_{10} = 0$
8	$-4T_8 + T_7 + T_5 + T_9 + T_{11} = 0$
9	$-4T_9 + T_8 + T_6 + 200 + T_{12} = 0$
10	$-4T_{10} + T_7 + 2T_{11} + T_{13} = 0$
11	$-4T_{11} + T_{10} + T_8 + T_{12} + T_{14} = 0$
12	$-4T_{12} + T_{11} + T_9 + 200 + T_{15} = 0$
13	$2T_{10} + T_{14} + 6.666 \times 30 - 10.666 T_{13} = 0$
14	$2T_{11} + T_{13} + T_{15} + 6.666 \times 30 - 2(3.333 + 2)T_{14} = 0$
15	$2T_{12} + T_{14} + 200 + 6.666 \times 30 - 2(3.333 + 2) T_{15} = 0$

Using the matrix inversion method, Section 4.5.2, the above equations can be written in the form  $[A][T] = [C]$  where  $[A]$  and  $[C]$  are shown on the next page. Using a stock matrix inversion routine, the temperatures  $[T]$  are determined.

Continued ...

**PROBLEM 4.73 (Cont.)**

$$[A] = \begin{bmatrix} -4 & 2 & 0 & 2 & 0 & 0 & 0 & 0 & 0 & 0 & 0 & 0 & 0 & 0 & 0 \\ 1 & -4 & 1 & 0 & 2 & 0 & 0 & 0 & 0 & 0 & 0 & 0 & 0 & 0 & 0 \\ 0 & 1 & -4 & 0 & 0 & -2 & 0 & 0 & 0 & 0 & 0 & 0 & 0 & 0 & 0 \\ 1 & 0 & 0 & -4 & 2 & 0 & 1 & 0 & 0 & 0 & 0 & 0 & 0 & 0 & 0 \\ 0 & 1 & 0 & 1 & -4 & 1 & 0 & 1 & 0 & 0 & 0 & 0 & 0 & 0 & 0 \\ 0 & 0 & 1 & 0 & 1 & -4 & 0 & 0 & 1 & 0 & 0 & 0 & 0 & 0 & 0 \\ 0 & 0 & 0 & 1 & 0 & 0 & -4 & 2 & 0 & 1 & 0 & 0 & 0 & 0 & 0 \\ 0 & 0 & 0 & 0 & 1 & 0 & 1 & -4 & 1 & 0 & 1 & 0 & 0 & 0 & 0 \\ 0 & 0 & 0 & 0 & 0 & 1 & 0 & 1 & -4 & 0 & 0 & 1 & 0 & 0 & 0 \\ 0 & 0 & 0 & 0 & 0 & 0 & 1 & 0 & 0 & -4 & 2 & 0 & 1 & 0 & 0 \\ 0 & 0 & 0 & 0 & 0 & 0 & 0 & 1 & 0 & -1 & -4 & 1 & 0 & 1 & 0 \\ 0 & 0 & 0 & 0 & 0 & 0 & 0 & 0 & 1 & 0 & 1 & -4 & 0 & 0 & 1 \\ 0 & 0 & 0 & 0 & 0 & 0 & 0 & 0 & 0 & 2 & 0 & 0 & -10.66 & 2 & 0 \\ 0 & 0 & 0 & 0 & 0 & 0 & 0 & 0 & 0 & 0 & 2 & 0 & 1 & -10.66 & 1 \\ 0 & 0 & 0 & 0 & 0 & 0 & 0 & 0 & 0 & 0 & 0 & 2 & 0 & 1 & -10.66 \end{bmatrix}$$

$$[C] = \begin{bmatrix} 0 \\ 0 \\ -200 \\ 0 \\ 0 \\ -200 \\ 0 \\ 0 \\ -200 \\ 0 \\ 0 \\ -200 \\ -200 \\ -200 \\ -200 \\ -400 \end{bmatrix} \quad [T] = \begin{bmatrix} T_1 \\ T_2 \\ T_3 \\ T_4 \\ T_5 \\ T_6 \\ T_7 \\ T_8 \\ T_9 \\ T_{10} \\ T_{11} \\ T_{12} \\ T_{13} \\ T_{14} \\ T_{15} \end{bmatrix} = \begin{bmatrix} 153.9 \\ 159.7 \\ 176.4 \\ 148.0 \\ 154.4 \\ 172.9 \\ 129.4 \\ 137.0 \\ 160.7 \\ 95.6 \\ 103.5 \\ 132.8 \\ 45.8 \\ 48.7 \\ 67.0 \end{bmatrix} \text{ (}^\circ\text{C)}$$

Considering symmetry, the heat transfer rate to the fluid is twice the convection rate from the surfaces of the control volumes exposed to the fluid. Using Newton's law of cooling, considering a unit thickness of the bar, find

$$q_{\text{conv}} = 2 \left[ h \cdot \frac{\Delta y}{2} \cdot (T_{13} - T_\infty) + h \cdot \Delta y \cdot (T_{14} - T_\infty) + h \cdot \Delta y \cdot (T_{15} - T_\infty) + h \cdot \frac{\Delta y}{2} (200 - T_\infty) \right]$$

$$q_{\text{conv}} = 2h \cdot \Delta y \left[ \frac{1}{2} (T_{13} - T_\infty) + (T_{14} - T_\infty) + (T_{15} - T_\infty) + \frac{1}{2} (200 - T_\infty) \right]$$

$$q_{\text{conv}} = 2 \times 50 \frac{\text{W}}{\text{m}^2 \cdot \text{K}} \times 0.1 \text{ m} \left[ \frac{1}{2} (45.8 - 30) + (48.7 - 30) + (67.0 - 30) + \frac{1}{2} (200 - 30) \right]$$

$$q_{\text{conv}} = 1487 \text{ W/m.}$$

<

### PROBLEM 4.74

**KNOWN:** Upper surface and grooves of a plate are maintained at a uniform temperature  $T_1$ , while the lower surface is maintained at  $T_2$  or is exposed to a fluid at  $T_\infty$ .

**FIND:** (a) Heat rate per width of groove spacing ( $w$ ) for isothermal top and bottom surfaces using a finite-difference method with  $\Delta x = 40$  mm, (b) Effect of grid spacing and convection at bottom surface.

**SCHEMATIC:**

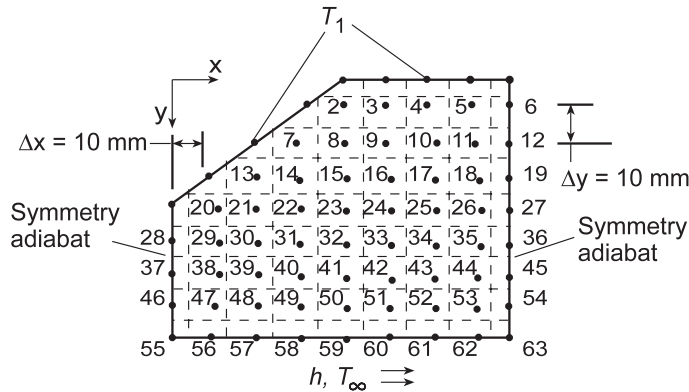
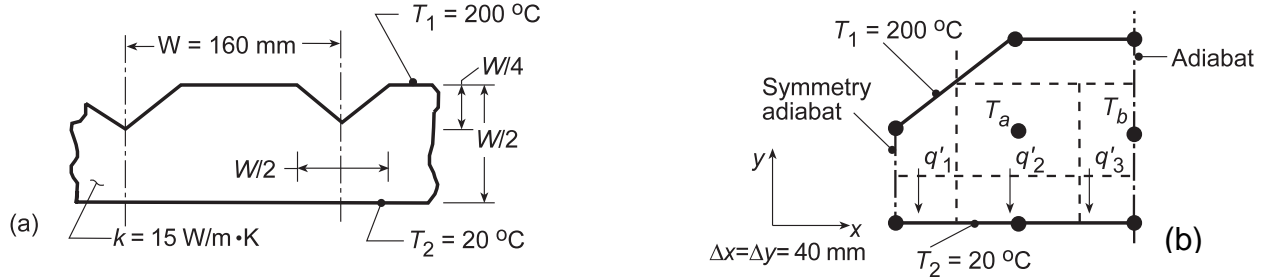

**ASSUMPTIONS:** (1) Steady-state, two-dimensional conduction, (2) Constant properties.

**ANALYSIS:** (a) Using a space increment of  $\Delta x = 40$  mm, the symmetrical section shown in schematic (b) corresponds to one-half the groove spacing. There exist only two interior nodes for which finite-difference equations must be written.

$$\begin{aligned} \text{Node a:} \quad 4T_a - (T_1 + T_b + T_2 + T_1) &= 0 \\ 4T_a - (200 + T_b + 20 + 200) &= 0 \quad \text{or} \quad 4T_a - T_b = 420 \end{aligned} \quad (1)$$

$$\begin{aligned} \text{Node b:} \quad 4T_b - (T_1 + T_a + T_2 + T_a) &= 0 \\ 4T_b - (200 + 2T_a + 20) &= 0 \quad \text{or} \quad -2T_a + 4T_b = 220 \end{aligned} \quad (2)$$

Multiply Eq. (2) by 2 and add to Eq. (1) to obtain  
 $7T_b = 860 \quad \text{or} \quad T_b = 122.9^\circ\text{C}$

From Eq. (1),  
 $4T_a - 122.9 = 420 \quad \text{or} \quad T_a = (420 + 122.9)/4 = 135.7^\circ\text{C}$ .

The heat transfer through the symmetrical section is equal to the sum of heat flows through control volumes adjacent to the lower surface. From the schematic,

$$q' = q'_1 + q'_2 + q'_3 = k \left( \frac{\Delta x}{2} \right) \frac{T_1 - T_2}{\Delta y} + k (\Delta x) \frac{T_a - T_2}{\Delta y} + k \left( \frac{\Delta x}{2} \right) \frac{T_b - T_2}{\Delta y}.$$

Continued...

### PROBLEM 4.74 (Cont.)

Noting that  $\Delta x = \Delta y$ , regrouping and substituting numerical values, find

$$q' = k \left[ \frac{1}{2}(T_1 - T_2) + (T_a - T_2) + \frac{1}{2}(T_b - T_2) \right]$$

$$q' = 15 \text{ W/m} \cdot \text{K} \left[ \frac{1}{2}(200 - 20) + (135.7 - 20) + \frac{1}{2}(122.9 - 20) \right] = 3.86 \text{ kW/m}.$$

For the full groove spacing,  $q'_{\text{total}} = 2 \times 3.86 \text{ kW/m} = 7.72 \text{ kW/m}$ . <

(b) Using the *Finite-Difference Equations* option from the *Tools* portion of the IHT menu, the following two-dimensional temperature field was computed for the grid shown in schematic (b), where  $x$  and  $y$  are in mm and the nodal temperatures are in  $^{\circ}\text{C}$ . Nodes 2-54 are interior nodes, with those along the symmetry adiabats characterized by  $T_{m-1,n} = T_{m+1,n}$ , while nodes 55-63 lie on a plane surface.

y\x	0	10	20	30	40	50	60	70	80
0					200	200	200	200	200
10				200	191	186.6	184.3	183.1	182.8
20			200	186.7	177.2	171.2	167.5	165.5	164.8
30		200	182.4	169.5	160.1	153.4	149.0	146.4	145.5
40	200	175.4	160.3	148.9	140.1	133.5	128.7	125.7	124.4
50	141.4	134.3	125.7	118.0	111.6	106.7	103.1	100.9	100.1
60	97.09	94.62	90.27	85.73	81.73	78.51	76.17	74.73	74.24
70	57.69	56.83	55.01	52.95	51.04	49.46	48.31	47.60	47.36
80	20	20	20	20	20	20	20	20	20

The foregoing results were computed for  $h = 10^7 \text{ W/m}^2 \cdot \text{K}$  ( $h \rightarrow \infty$ ) and  $T_{\infty} = 20^{\circ}\text{C}$ , which is tantamount to prescribing an isothermal bottom surface at  $20^{\circ}\text{C}$ . Agreement between corresponding results for the coarse and fine grids is surprisingly good ( $T_a = 135.7^{\circ}\text{C} \leftrightarrow T_{23} = 140.1^{\circ}\text{C}$ ;  $T_b = 122.9^{\circ}\text{C} \leftrightarrow T_{27} = 124.4^{\circ}\text{C}$ ). The heat rate is

$$q' = 2 \times k \left[ (T_{46} - T_{55})/2 + (T_{47} - T_{56}) + (T_{48} - T_{57}) + (T_{49} - T_{58}) + (T_{50} - T_{59}) \right. \\ \left. + (T_{51} - T_{60}) + (T_{52} - T_{61}) + (T_{53} - T_{62}) + (T_{54} - T_{63})/2 \right]$$

$$q' = 2 \times 15 \text{ W/m} \cdot \text{K} [18.84 + 36.82 + 35.00 + 32.95 + 31.04 + 29.46 \\ + 28.31 + 27.6 + 13.68]^{\circ}\text{C} = 7.61 \text{ kW/m}$$
<

The agreement with  $q' = 7.72 \text{ kW/m}$  from the coarse grid of part (a) is excellent and a fortuitous consequence of compensating errors. With reductions in the convection coefficient from  $h \rightarrow \infty$  to  $h = 1000, 200$  and  $5 \text{ W/m}^2 \cdot \text{K}$ , the corresponding increase in the thermal resistance reduces the heat rate to values of 6.03, 3.28 and 0.14 kW/m, respectively. With decreasing  $h$ , there is an overall increase in nodal temperatures, as, for example, from  $191^{\circ}\text{C}$  to  $199.8^{\circ}\text{C}$  for  $T_2$  and from  $20^{\circ}\text{C}$  to  $196.9^{\circ}\text{C}$  for  $T_{55}$ .

**NOTE TO INSTRUCTOR:** To reduce computational effort, while achieving the same educational objectives, the problem statement has been changed to allow for convection at the bottom, rather than the top, surface.

### PROBLEM 4.75

**KNOWN:** Rectangular plate subjected to uniform temperature boundaries.

**FIND:** Temperature at the midpoint using a finite-difference method with space increment of 0.25m

**SCHEMATIC:**

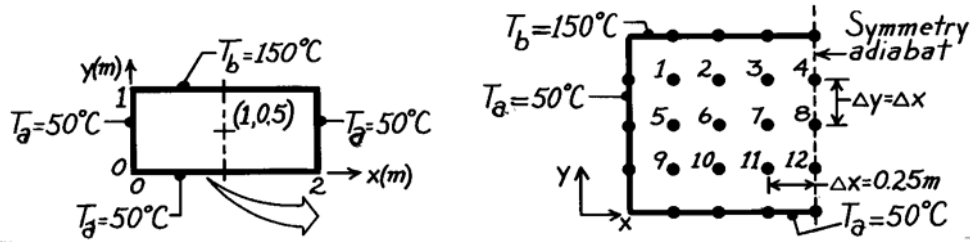

**ASSUMPTIONS:** (1) Steady-state conditions, (2) Two-dimensional conduction, (3) Constant properties.

**ANALYSIS:** For the nodal network above, 12 finite-difference equations must be written. It follows that node 8 represents the midpoint of the rectangle. Since all nodes are interior nodes, Eq. 4.29 is appropriate and is written in the form

$$4T_m - \sum T_{\text{neighbors}} = 0.$$

For nodes on the symmetry adiabat, the neighboring nodes include two symmetrical nodes. Hence, for Node 4, the neighbors are  $T_b$ ,  $T_8$  and  $2T_3$ . Because of the simplicity of the finite-difference equations, we may proceed directly to the matrices [A] and [C] – see Eq. 4.48 – and matrix inversion can be used to find the nodal temperatures  $T_m$ .

$$A = \begin{bmatrix} -4 & 1 & 0 & 0 & 1 & 0 & 0 & 0 & 0 & 0 & 0 & 0 \\ 1 & -4 & 1 & 0 & 0 & 1 & 0 & 0 & 0 & 0 & 0 & 0 \\ 0 & 1 & -4 & 1 & 0 & 0 & 1 & 0 & 0 & 0 & 0 & 0 \\ 0 & 0 & 2 & -4 & 0 & 0 & 0 & 1 & 0 & 0 & 0 & 0 \\ 1 & 0 & 0 & 0 & -4 & 1 & 0 & 0 & 1 & 0 & 0 & 0 \\ 0 & 1 & 0 & 0 & 1 & -4 & 1 & 0 & 0 & 1 & 0 & 0 \\ 0 & 0 & 1 & 0 & 0 & 1 & -4 & 1 & 0 & 0 & 1 & 0 \\ 0 & 0 & 0 & 1 & 0 & 0 & 2 & -4 & 0 & 0 & 0 & 1 \\ 0 & 0 & 0 & 0 & 1 & 0 & 0 & 0 & -4 & 1 & 0 & 0 \\ 0 & 0 & 0 & 0 & 0 & 1 & 0 & 0 & 1 & -4 & 1 & 0 \\ 0 & 0 & 0 & 0 & 0 & 0 & 1 & 0 & 0 & 1 & -4 & 1 \\ 0 & 0 & 0 & 0 & 0 & 0 & 0 & 1 & 0 & 0 & 2 & -4 \end{bmatrix} \quad C = \begin{bmatrix} -200 \\ -150 \\ -150 \\ -150 \\ -50 \\ 0 \\ 0 \\ 0 \\ -100 \\ -50 \\ -50 \\ -50 \end{bmatrix} \quad T = \begin{bmatrix} 96.5 \\ 112.9 \\ 118.9 \\ 120.4 \\ 73.2 \\ 86.2 \\ 92.3 \\ 94.0 \\ 59.9 \\ 65.5 \\ 69.9 \\ 71.0 \end{bmatrix}$$

The temperature at the midpoint (Node 8) is

$$T(1,0.5) = T_8 = 94.0^\circ\text{C}.$$

<

**COMMENTS:** Using the exact analytical, solution – see Eq. 4.19 and Problem 4.2 – the midpoint temperature is found to be 94.5°C. To improve the accuracy of the finite-difference method, it would be necessary to decrease the nodal mesh size.

## PROBLEM 4.76

**KNOWN:** Edge of adjoining walls ( $k = 1 \text{ W/m}\cdot\text{K}$ ) represented by symmetrical element bounded by the diagonal symmetry adiabat and a section of the wall thickness over which the temperature distribution is assumed to be linear.

**FIND:** (a) Temperature distribution, heat rate and shape factor for the edge using the nodal network with  $\Delta x = \Delta y = 10 \text{ mm}$ ; compare shape factor result with that from Table 4.1; (b) Assess the validity of assuming linear temperature distributions across sections at various distances from the edge.

**SCHEMATIC:**

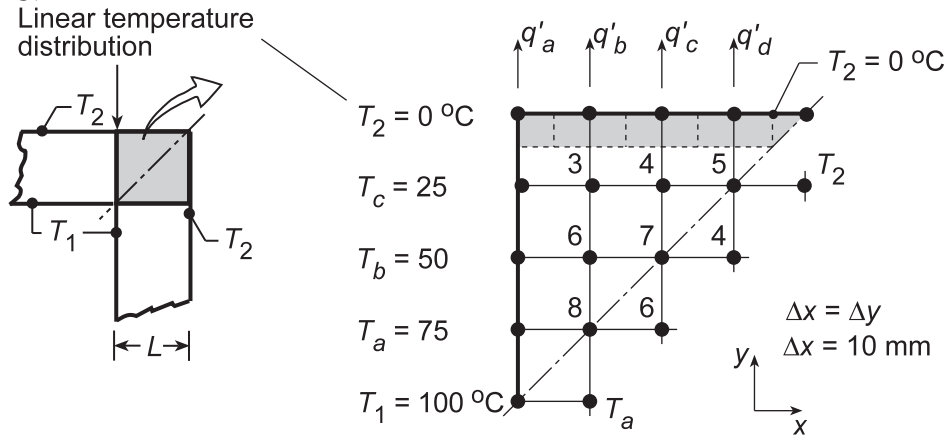

**ASSUMPTIONS:** (1) Two-dimensional, steady-state conduction, (2) Constant properties, and (3) Linear temperature distribution at specified locations across the section.

**ANALYSIS:** (a) Taking advantage of symmetry along the adiabat diagonal, all the nodes may be treated as interior nodes. Across the left-hand boundary, the temperature distribution is specified as linear. The finite-difference equations required to determine the temperature distribution, and hence the heat rate, can be written by inspection.

$$T_3 = 0.25(T_2 + T_4 + T_6 + T_c)$$

$$T_4 = 0.25(T_2 + T_5 + T_7 + T_3)$$

$$T_5 = 0.25(T_2 + T_2 + T_4 + T_4)$$

$$T_6 = 0.25(T_3 + T_7 + T_8 + T_b)$$

$$T_7 = 0.25(T_4 + T_4 + T_6 + T_6)$$

$$T_8 = 0.25(T_6 + T_6 + T_a + T_a)$$

The heat rate for both surfaces of the edge is

$$q'_{\text{tot}} = 2[q'_a + q'_b + q'_c + q'_d]$$

$$q'_{\text{tot}} = 2\left[k(\Delta x/2)(T_c - T_2)/\Delta y + k\Delta x(T_3 - T_2)/\Delta y + k\Delta x(T_4 - T_2)/\Delta y + k\Delta x(T_5 - T_2)/\Delta x\right]$$

The shape factor for the full edge is defined as

$$q'_{\text{tot}} = kS'(T_1 - T_2)$$

Solving the above equation set in IHT, the temperature ( $^{\circ}\text{C}$ ) distribution is

Continued...



### PROBLEM 4.77

**KNOWN:** Long triangular bar insulated on the diagonal while sides are maintained at uniform temperatures  $T_a$  and  $T_b$ .

**FIND:** (a) Using a nodal network with five nodes to the side, and beginning with properly defined control volumes, derive the finite-difference equations for the interior and diagonal nodes and obtain the temperature distribution; sketch the 25, 50 and 75°C isotherms and (b) Recognizing that the insulated diagonal surface can be treated as a symmetry line, show that the diagonal nodes can be treated as interior nodes, and write the finite-difference equations by inspection.

**SCHEMATIC:**

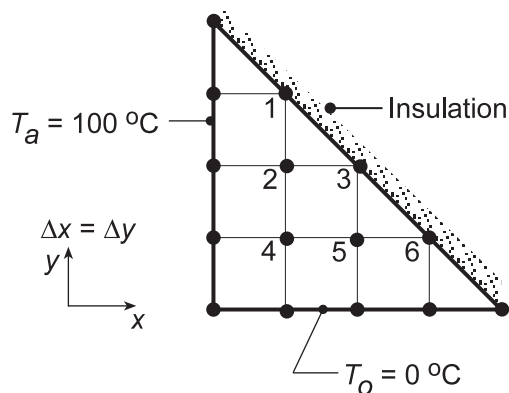

**ASSUMPTIONS:** (1) Steady-state conditions, (2) Two-dimensional heat transfer, and (3) Constant properties.

**ANALYSIS:** (a) For the nodal network shown above, nodes 2, 4, and 5 are interior nodes and, since  $\Delta x = \Delta y$ , the corresponding finite-difference equations are of the form, Equation 4.29,

$$T_j = 1/4 \sum T_{\text{neighbors}} \quad (1)$$

For a node on the adiabatic, diagonal surface, an energy balance,  $\dot{E}_{\text{in}} - \dot{E}_{\text{out}} = 0$ , yields

$$\begin{aligned} q'_a + q'_b + q'_c &= 0 \\ 0 + k\Delta x \frac{T_5 - T_3}{\Delta y} + k\Delta y \frac{T_2 - T_3}{\Delta x} &= 0 \\ T_3 &= 1/2(T_2 + T_5) \end{aligned} \quad (2)$$

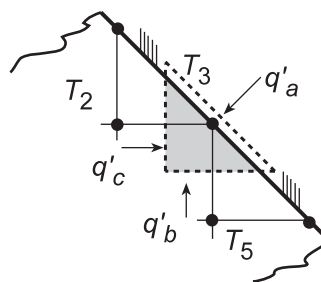

That is, for the diagonal nodes, m,

$$T_m = 1/2 \sum T_{\text{neighbors}} \quad (3)$$

To obtain the temperature distributions, enter Eqs. (1, 2, 3) into the IHT workspace and solve for the nodal temperatures (°C), tabulated according to the nodal arrangement:

Continued...



**PROBLEM 4.77 (Cont.)**

-				
100	85.71			
100	71.43	50.00		
100	50.00	28.57	14.29	
-	0	0	0	-

The 25, 50 and 75°C isotherms are sketched below, using an interpolation scheme to scale the isotherms on the triangular bar.

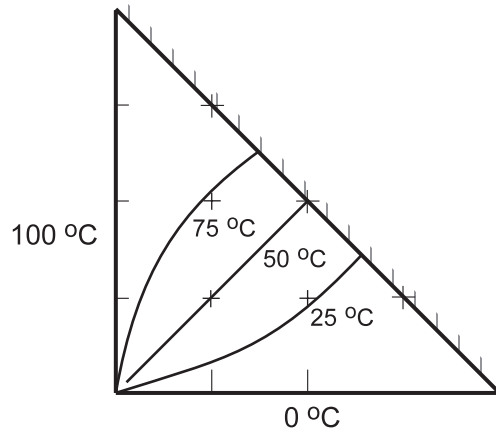

(b) If we consider the insulated surface as a symmetry plane, the nodal network appears as shown. As such, the diagonal nodes can be treated as interior nodes, as Eq. (1) above applies. Recognize the form is the same as that of Eq. (2) or (3).

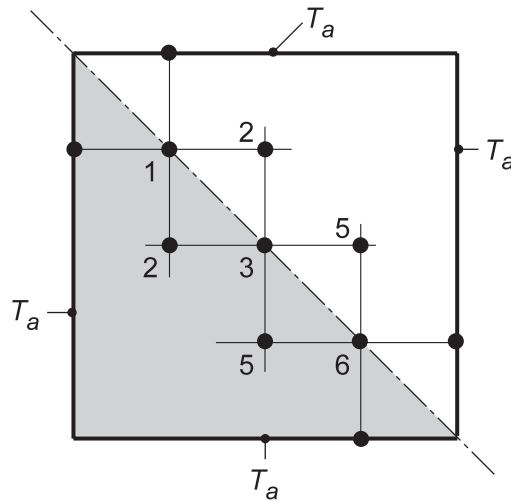

**COMMENTS:** Always look for symmetry conditions which can greatly simplify the writing of nodal equations. In this situation, the adiabatic surface can be treated as a symmetry plane such that the nodes can be treated as interior nodes, and the finite-difference equations can be written by inspection.

## PROBLEM 4.78

**KNOWN:** Straight fin of uniform cross section with insulated end.

**FIND:** (a) Temperature distribution using finite-difference method and validity of assuming one-dimensional heat transfer, (b) Fin heat transfer rate and comparison with analytical solution, Eq. 3.81, (c) Effect of convection coefficient on fin temperature distribution and heat rate.

**SCHEMATIC:**

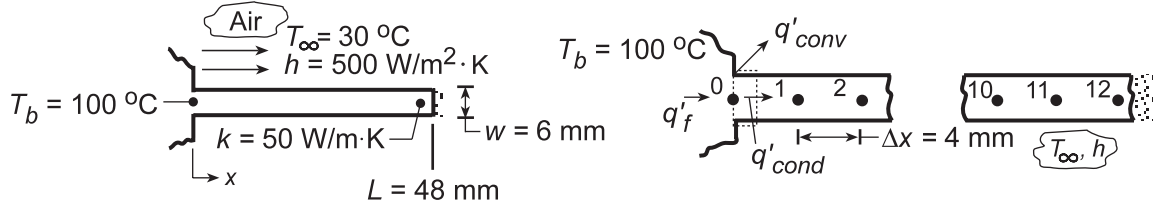

**ASSUMPTIONS:** (1) Steady-state conditions, (2) One-dimensional conduction in fin, (3) Constant properties, (4) Uniform film coefficient.

**ANALYSIS:** (a) From the analysis of Problem 4.50, the finite-difference equations for the nodal arrangement can be directly written. For the nodal spacing  $\Delta x = 4$  mm, there will be 12 nodes. With  $l \gg w$  representing the distance normal to the page,

$$\frac{hP}{kA_c} \cdot \Delta x^2 \approx \frac{h \cdot 2\ell}{k \cdot \ell \cdot w} \Delta x^2 = \frac{h \cdot 2}{kw} \Delta x^2 = \frac{500 \text{ W/m}^2 \cdot \text{K} \times 2}{50 \text{ W/m} \cdot \text{K} \times 6 \times 10^{-3} \text{ m}} \left(4 \times 10^{-3} \text{ m}\right) = 0.0533$$

$$\text{Node 1: } 100 + T_2 + 0.0533 \times 30 - (2 + 0.0533)T_1 = 0 \quad \text{or} \quad -2.053T_1 + T_2 = -101.6$$

$$\text{Node } n: \quad T_{n+1} + T_{n-1} + 1.60 - 2.0533T_n = 0 \quad \text{or} \quad T_{n-1} - 2.053T_n + T_{n+1} = -1.60$$

$$\text{Node 12: } T_{11} + (0.0533/2)30 - (0.0533/2 + 1)T_{12} = 0 \quad \text{or} \quad T_{11} - 1.0267T_{12} = -0.800$$

Using matrix notation, Eq. 4.48, where  $[A][T] = [C]$ , the A-matrix is tridiagonal and only the non-zero terms are shown below. A matrix inversion routine was used to obtain  $[T]$ .

*Tridiagonal Matrix A*

*Column Matrices*

Nonzero Terms				Values		Node	C	T
	$a_{1,1}$	$a_{1,2}$		-2.053	1	1	-101.6	85.8
$a_{2,1}$	$a_{2,2}$	$a_{2,3}$	1	-2.053	1	2	-1.6	74.5
$a_{3,2}$	$a_{3,3}$	$a_{3,4}$	1	-2.053	1	3	-1.6	65.6
$a_{4,3}$	$a_{4,4}$	$a_{4,5}$	1	-2.053	1	4	-1.6	58.6
$a_{5,4}$	$a_{5,5}$	$a_{5,6}$	1	-2.053	1	5	-1.6	53.1
$a_{6,5}$	$a_{6,6}$	$a_{6,7}$	1	-2.053	1	6	-1.6	48.8
$a_{7,6}$	$a_{7,7}$	$a_{7,8}$	1	-2.053	1	7	-1.6	45.5
$a_{8,7}$	$a_{8,8}$	$a_{8,9}$	1	-2.053	1	8	-1.6	43.0
$a_{9,8}$	$a_{9,9}$	$a_{9,10}$	1	-2.053	1	9	-1.6	41.2
$a_{10,9}$	$a_{10,10}$	$a_{10,11}$	1	-2.053	1	10	-1.6	39.9
$a_{11,10}$	$a_{11,11}$	$a_{11,12}$	1	-2.053	1	11	-1.6	39.2
$a_{12,11}$	$a_{12,12}$	$a_{12,13}$	1	-1.027	1	12	-0.8	38.9

The assumption of one-dimensional heat conduction is justified when  $Bi \equiv h(w/2)/k < 0.1$ . Hence, with  $Bi = 500 \text{ W/m}^2 \cdot \text{K}(3 \times 10^{-3} \text{ m})/50 \text{ W/m} \cdot \text{K} = 0.03$ , the assumption is reasonable.

Continued...

### PROBLEM 4.78 (Cont.)

(b) The fin heat rate can be most easily found from an energy balance on the control volume about Node 0,

$$q'_f = q'_1 + q'_{\text{conv}} = k \cdot w \frac{T_0 - T_1}{\Delta x} + h \left( 2 \frac{\Delta x}{2} \right) (T_0 - T_\infty)$$

$$q'_f = 50 \text{ W/m} \cdot \text{K} \left( 6 \times 10^{-3} \text{ m} \right) \frac{(100 - 85.8)^\circ \text{C}}{4 \times 10^{-3} \text{ m}} + 500 \text{ W/m}^2 \cdot \text{K} \left( 2 \cdot \frac{4 \times 10^{-3} \text{ m}}{2} \right) (100 - 30)^\circ \text{C}$$

$$q'_f = (1065 + 140) \text{ W/m} = 1205 \text{ W/m} . \quad \leftarrow$$

From Eq. 3.81, the fin heat rate is

$$q = (hPkA_c)^{1/2} \cdot \theta_b \cdot \tanh mL .$$

Substituting numerical values with  $P = 2(w + \ell) \approx 2\ell$  and  $A_c = w \cdot \ell$ ,  $m = (hP/kA_c)^{1/2} = 57.74 \text{ m}^{-1}$  and  $M = (hPkA_c)^{1/2} = 17.32 \ell \text{ W/K}$ . Hence, with  $\theta_b = 70^\circ\text{C}$ ,

$$q' = 17.32 \text{ W/K} \times 70 \text{ K} \times \tanh(57.44 \times 0.048) = 1203 \text{ W/m}$$

and the finite-difference result agrees very well with the exact (analytical) solution.

(c) Using the IHT *Finite-Difference Equations Tool Pad* for 1D, SS conditions, the fin temperature distribution and heat rate were computed for  $h = 10, 100, 500$  and  $1000 \text{ W/m}^2 \cdot \text{K}$ . Results are plotted as follows.

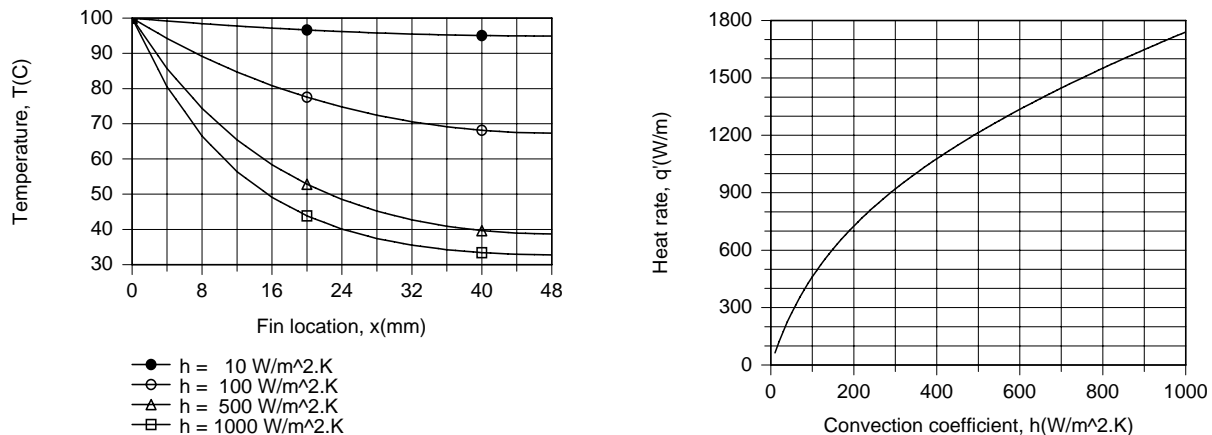

The temperature distributions were obtained by first creating a *Lookup Table* consisting of 4 rows of nodal temperatures corresponding to the 4 values of  $h$  and then using the *LOOKUPVAL2* interpolating function with the *Explore* feature of the IHT menu. Specifically, the function  $T\_EVAL = \text{LOOKUPVAL2}(t0467, h, x)$  was entered into the workspace, where  $t0467$  is the file name given to the Lookup Table. For each value of  $h$ , *Explore* was used to compute  $T(x)$ , thereby generating 4 data sets which were placed in the *Browser* and used to generate the plots. The variation of  $q'$  with  $h$  was simply generated by using the *Explore* feature to solve the finite-difference model equations for values of  $h$  incremented by 10 from 10 to  $1000 \text{ W/m}^2 \cdot \text{K}$ .

Although  $q'_f$  increases with increasing  $h$ , the effect of changes in  $h$  becomes less pronounced. This trend is a consequence of the reduction in fin temperatures, and hence the fin efficiency, with increasing  $h$ . For  $10 \leq h \leq 1000 \text{ W/m}^2 \cdot \text{K}$ ,  $0.95 \geq \eta_f \geq 0.24$ . Note the nearly isothermal fin for  $h = 10 \text{ W/m}^2 \cdot \text{K}$  and the pronounced temperature decay for  $h = 1000 \text{ W/m}^2 \cdot \text{K}$ .

### PROBLEM 4.79

**KNOWN:** Pin fin of 10 mm diameter and length 250 mm with base temperature of 100°C experiencing radiation exchange with the surroundings and free convection with ambient air.

**FIND:** Temperature distribution using finite-difference method with five nodes. Fin heat rate and relative contributions by convection and radiation.

**SCHEMATIC:**

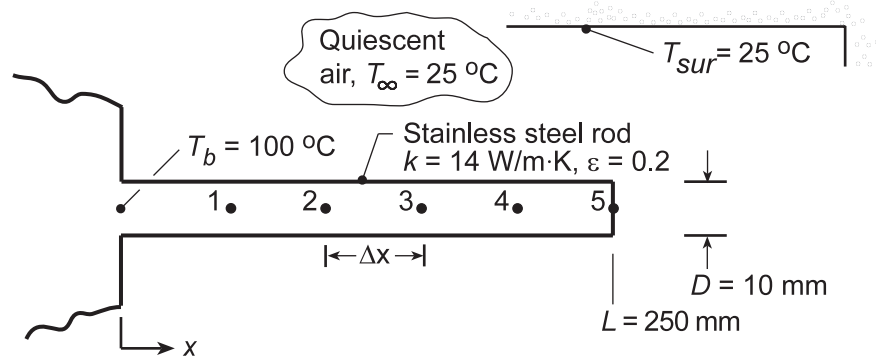

**ASSUMPTIONS:** (1) Steady-state conditions, (2) One-dimensional conduction in fin, (3) Constant properties, (4) Fin approximates small object in large enclosure, (5) Fin tip experiences convection and radiation, (6)  $h_{fc} = 2.89[0.6 + 0.624(T - T_\infty)^{1/6}]^2$ .

**ANALYSIS:** To apply the finite-difference method, define the 5-node system shown above where  $\Delta x = L/5$ . Perform energy balances on the nodes to obtain the finite-difference equations for the nodal temperatures.

*Interior node,  $n = 1, 2, 3$  or  $4$*

$$\dot{E}_{in} - \dot{E}_{out} = 0$$

$$q_a + q_b + q_c + q_d = 0 \quad (1)$$

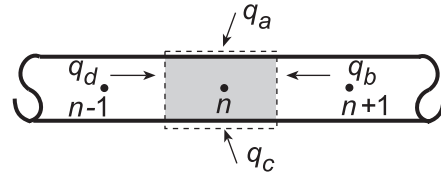

$$h_{r,n} P \Delta x (T_{sur} - T_n) + k A_c \frac{T_{n+1} - T_n}{\Delta x} + h_{fc,n} P \Delta x (T_\infty - T_n) + k A_c \frac{T_{n-1} - T_n}{\Delta x} = 0 \quad (2)$$

where the free convection coefficient is

$$h_{fc,n} = 2.89 \left[ 0.6 + 0.624 (T_n - T_\infty)^{1/6} \right]^2 \quad (3)$$

and the linearized radiation coefficient is

$$h_{r,n} = \epsilon \sigma (T_n + T_{sur}) (T_n^2 + T_{sur}^2) \quad (4)$$

with  $P = \pi D$  and  $A_c = \pi D^2/4$ .

(5,6)

*Tip node,  $n = 5$*

$$\dot{E}_{in} - \dot{E}_{out} = 0$$

$$q_a + q_b + q_c + q_d + q_e = 0$$

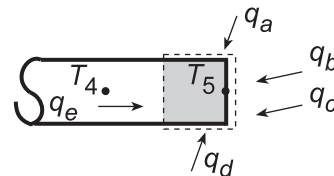

$$h_{r,5} (P \Delta x / 2) (T_{sur} - T_5) + h_{r,5} A_c (T_{sur} - T_5) + h_{fc,5} A_c (T_\infty - T_5) + h_{fc,5} (P \Delta x / 2) (T_\infty - T_5) + k A_c \frac{T_4 - T_5}{\Delta x} = 0 \quad (7)$$

Continued...

### PROBLEM 4.79 (Cont.)

Knowing the nodal temperatures, the heat rates are evaluated as:

*Fin Heat Rate:* Perform an energy balance around Node b.

$$\dot{E}_{\text{in}} - \dot{E}_{\text{out}} = 0$$

$$q_a + q_b + q_c + q_{\text{fin}} = 0$$

$$h_{r,b} (P\Delta x/2)(T_{\text{sur}} - T_b) + h_{fc,b} (P\Delta x/2)(T_{\infty} - T_b) + kA_c \frac{(T_1 - T_b)}{\Delta x} + q_{\text{fin}} = 0 \quad (8)$$

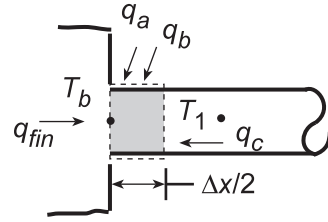

where  $h_{r,b}$  and  $h_{fc,b}$  are evaluated at  $T_b$ .

*Convection Heat Rate:* To determine the portion of the heat rate by convection from the fin surface, we need to sum contributions from each node. Using the convection heat rate terms from the foregoing energy balances, for, respectively, node b, nodes 1, 2, 3, 4 and node 5.

$$q_{cv} = -q_b)_b - \sum q_c)_{1-4} - (q_c + q_d)_5 \quad (9)$$

*Radiation Heat Rate:* In the same manner,

$$q_{\text{rad}} = -q_a)_b - \sum q_b)_{1-4} - (q_a + q_b)_5$$

The above equations were entered into the IHT workspace and the set of equations solved for the nodal temperatures and the heat rates. Summary of key results including the temperature distribution and heat rates is shown below.

Node	b	1	2	3	4	5	Fin	<
$T_j$ (°C)	100	58.5	40.9	33.1	29.8	28.8	-	
$q_{cv}$ (W)	0.603	0.451	0.183	0.081	0.043	0.015	1.375	
$q_{\text{fin}}$ (W)	-	-	-	-	-	-	1.604	
$q_{\text{rad}}$ (W)	-	-	-	-	-	-	0.229	
$h_{cv}$ (W/m <sup>2</sup> ·K)	10.1	8.6	7.3	6.4	5.7	5.5	-	
$h_{\text{rad}}$ (W/m <sup>2</sup> ·K)	1.5	1.4	1.3	1.3	1.2	1.2	-	

**COMMENTS:** From the tabulated results, it is evident that free convection is the dominant mode. Note that the free convection coefficient varies almost by a factor of two over the length of the fin.

### PROBLEM 4.80

**KNOWN:** Silicon chip mounted in a dielectric substrate. One surface of system is convectively cooled while the remaining surfaces are well insulated.

**FIND:** Whether maximum temperature in chip will exceed 85°C.

**SCHEMATIC:**

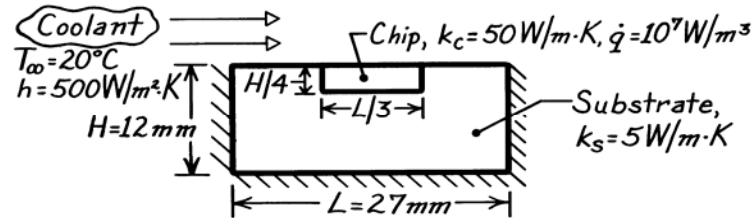

**ASSUMPTIONS:** (1) Steady-state conditions, (2) Two-dimensional conduction, (3) Negligible contact resistance between chip and substrate, (4) Upper surface experiences uniform convection coefficient, (5) Other surfaces are perfectly insulated.

**ANALYSIS:** Performing an energy balance on the chip assuming it is *perfectly insulated* from the substrate, the maximum temperature occurring at the interface with the dielectric substrate will be, according to Eqs. 3.48 and 3.51,

$$T_{\max} = \frac{\dot{q}(H/4)^2}{2k_c} + \frac{\dot{q}(H/4)}{h} + T_{\infty} = \frac{10^7 \text{ W/m}^3 (0.003 \text{ m})^2}{2 \times 50 \text{ W/m} \cdot \text{K}} + \frac{10^7 \text{ W/m}^3 (0.003 \text{ m})}{500 \text{ W/m}^2 \cdot \text{K}} + 20^\circ \text{C} = 80.9^\circ \text{C}.$$

Since  $T_{\max} < 85^\circ \text{C}$  for the assumed situation, for the actual two-dimensional situation with the conducting dielectric substrate, the maximum temperature should be less than 80°C.

Using the suggested grid spacing of 3 mm, construct the nodal network and write the finite-difference equation for each of the nodes taking advantage of symmetry of the system. Note that we have chosen to *not* locate nodes on the system surfaces for two reasons: (1) fewer total number of nodes, 20 vs. 25, and (2) Node 5 corresponds to center of chip which is likely the point of maximum temperature. Using these numerical values,

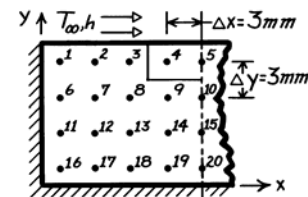

$$\frac{h\Delta x}{k_s} = \frac{500 \text{ W/m}^2 \cdot \text{K} \times 0.003 \text{ m}}{5 \text{ W/m} \cdot \text{K}} = 0.30 \quad \alpha = \frac{2}{(k_s/k_c) + 1} = \frac{2}{5/50 + 1} = 1.818$$

$$\frac{h\Delta x}{k_c} = \frac{500 \text{ W/m}^2 \cdot \text{K} \times 0.003 \text{ m}}{5 \text{ W/m} \cdot \text{K}} = 0.030 \quad \beta = \frac{2}{(k_c/k_s) + 1} = \frac{2}{50/5 + 1} = 0.182$$

$$\frac{\dot{q}\Delta x\Delta y}{k_c} = 1.800 \quad \gamma = \frac{1}{k_c/k_s + 1} = 0.0910$$

find the nodal equations:

$$\text{Node 1} \quad k_s\Delta x \frac{T_6 - T_1}{\Delta y} + k_s\Delta y \frac{T_2 - T_1}{\Delta x} + h\Delta x (T_{\infty} - T_1) = 0$$

Continued ...

**PROBLEM 4.80 (Cont.)**

$$-\left(2 + \frac{h\Delta x}{k_s}\right)T_1 + T_2 + T_6 = -\frac{h\Delta x}{k_s}T_\infty \quad -2.30T_1 + T_2 + T_6 = -6.00 \quad (1)$$

Node 2  $T_1 - 3.3T_2 + T_3 + T_7 = -6.00 \quad (2)$

Node 3

$$k_s\Delta y \frac{T_2 - T_3}{\Delta x} + \frac{T_4 - T_3}{(\Delta x/2)/k_c\Delta y + (\Delta x/2)/k_s\Delta y} + k_s\Delta x \frac{T_8 - T_3}{\Delta y} + h\Delta x (T_\infty - T_3) = 0$$

$$T_2 - (2 + \alpha + (h\Delta x/k_s)T_3) + \alpha T_4 + T_8 = -(h\Delta x/k)T_\infty$$

$$T_2 - 4.12T_3 + 1.82T_4 + T_8 = -6.00 \quad (3)$$

Node 4

$$\frac{T_3 - T_4}{(\Delta x/2)/k_s\Delta y + (\Delta x/2)/k_c\Delta y} + k_c\Delta y \frac{T_5 - T_4}{\Delta x} + \frac{T_9 - T_4}{(\Delta y/2)/k_s\Delta x + (\Delta y/2)k_c\Delta x} + \dot{q}(\Delta x\Delta y) + h\Delta x (T_\infty - T_4) = 0$$

$$\beta T_3 - (1 + 2\beta + [h\Delta x/k_c])T_4 + T_5 + \beta T_9 = -(h\Delta x/k_c)T_\infty - \dot{q}\Delta x\Delta y/k_c$$

$$0.182T_3 - 1.39T_4 + T_5 + 0.182T_9 = -2.40 \quad (4)$$

Node 5

$$k_c\Delta y \frac{T_4 - T_5}{\Delta x} + \frac{T_{10} - T_5}{(\Delta y/2)/k_s(\Delta x/2) + (\Delta y/2)/k_c(\Delta x/2)} + h(\Delta x/2)(T_\infty - T_5) + \dot{q}\Delta y(\Delta x/2) = 0$$

$$2T_4 - 2.21T_5 + 0.182T_{10} = -2.40 \quad (5)$$

Nodes 6 and 11

$$k_s\Delta x (T_1 - T_6)/\Delta y + k_s\Delta y (T_7 - T_6)/\Delta x + k_s\Delta x (T_{11} - T_6)/\Delta y = 0$$

$$T_1 - 3T_6 + T_7 + T_{11} = 0 \quad T_6 - 3T_{11} + T_{12} + T_{16} = 0 \quad (6,11)$$

Nodes 7, 8, 12, 13, 14 Treat as interior points,

$$T_2 + T_6 - 4T_7 + T_8 + T_{12} = 0 \quad T_3 + T_7 - 4T_8 + T_9 + T_{13} = 0 \quad (7,8)$$

$$T_7 + T_{11} - 4T_{12} + T_{13} + T_{17} = 0 \quad T_8 + T_{12} - 4T_{13} + T_{14} + T_{18} = 0 \quad (12,13)$$

$$T_9 + T_{13} - 4T_{14} + T_{15} + T_{19} = 0 \quad (14)$$

Node 9

$$k_s\Delta y \frac{T_8 - T_9}{\Delta x} + \frac{T_4 - T_9}{(\Delta y/2)/k_c\Delta x + (\Delta y/2)/k_s\Delta x} + k_s\Delta y \frac{T_{10} - T_9}{\Delta x} + k_s\Delta x \frac{T_{14} - T_9}{\Delta y} = 0$$

$$1.82T_4 + T_8 - 4.82T_9 + T_{10} + T_{14} = 0 \quad (9)$$

Node 10 Using the result of Node 9 and considering symmetry,

$$1.82T_5 + 2T_9 - 4.82T_{10} + T_{15} = 0 \quad (10)$$

Node 15 Interior point considering symmetry  $T_{10} + 2T_{14} - 4T_{15} + T_{20} = 0 \quad (15)$

Node 16 By inspection,  $T_{11} - 2T_{16} + T_{17} = 0 \quad (16)$

Continued ...





## PROBLEM 4.81

**KNOWN:** Heat sink for cooling computer chips fabricated from copper with microchannels passing fluid with prescribed temperature and convection coefficient.

**FIND:** (a) Using a square nodal network with  $100\ \mu\text{m}$  spatial increment, determine the temperature distribution and the heat rate to the coolant per unit channel length for maximum allowable chip temperature  $T_{c,\text{max}} = 75^\circ\text{C}$ ; estimate the thermal resistance between the chip surface and the fluid,  $R'_{t,c-f}$  ( $\text{m}\cdot\text{K}/\text{W}$ ); maximum allowable heat dissipation for a chip that measures  $10 \times 10\ \text{mm}$  on a side; (b) The effect of grid spacing by considering spatial increments of  $50$  and  $25\ \mu\text{m}$ ; and (c) Consistent with the requirement that  $a + b = 400\ \mu\text{m}$ , explore altering the sink dimensions to decrease the thermal resistance.

**SCHEMATIC:**

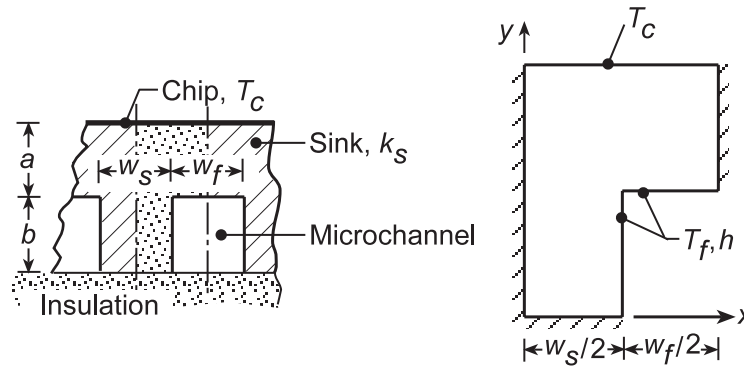

**ASSUMPTIONS:** (1) Steady-state, two-dimensional conduction, (2) Constant properties, and (3) Convection coefficient is uniform over the microchannel surface and independent of the channel dimensions and shape.

**ANALYSIS:** (a) The square nodal network with  $\Delta x = \Delta y = 100\ \mu\text{m}$  is shown below. Considering symmetry, the nodes 1, 2, 3, 4, 7, and 9 can be treated as interior nodes and their finite-difference equations representing nodal energy balances can be written by inspection. Using the *IHT Finite-Difference Equations Tool*, appropriate FDEs for the nodes experiencing surface convection can be obtained. The IHT code along with results is included in the Comments. Having the temperature distribution, the heat rate to the coolant per unit channel length for two symmetrical elements can be obtained by applying Newton's law of cooling to the surface nodes,

$$q'_{\text{cv}} = 2 \left[ h \left( \frac{\Delta y}{2} + \frac{\Delta x}{2} \right) (T_5 - T_\infty) + h \left( \frac{\Delta x}{2} \right) (T_6 - T_\infty) + h (\Delta y) (T_8 - T_\infty) + h \left( \frac{\Delta y}{2} \right) (T_{10} - T_\infty) \right]$$

$$q'_{\text{cv}} = 2 \times 30,000\ \text{W}/\text{m}^2 \cdot \text{K} \times 100 \times 10^{-6}\ \text{m} \left[ (74.02 - 25) + (74.09 - 25)/2 + (73.60 - 25) + (73.37 - 25)/2 \right] \text{K}$$

$$q'_{\text{cv}} = 878\ \text{W}/\text{m} \quad <$$

The thermal resistance between the chip and fluid per unit length for each microchannel is

$$R'_{t,c-f} = \frac{T_c - T_\infty}{q'_{\text{cv}}} = \frac{(75 - 25)^\circ\text{C}}{878\ \text{W}/\text{m}} = 5.69 \times 10^{-2}\ \text{m}\cdot\text{K}/\text{W} \quad <$$

The maximum allowable heat dissipation for a  $10\ \text{mm} \times 10\ \text{mm}$  chip is

$$P_{\text{chip,max}} = q''_c \times A_{\text{chip}} = 2.20 \times 10^6\ \text{W}/\text{m}^2 \times (0.01 \times 0.01)\ \text{m}^2 = 220\ \text{W} \quad <$$

where  $A_{\text{chip}} = 10\ \text{mm} \times 10\ \text{mm}$  and the heat flux on the chip surface ( $w_f + w_s$ ) is

$$q''_c = q'_{\text{cv}} / (w_f + w_s) = 878\ \text{W}/\text{m} / (200 + 200) \times 10^{-6}\ \text{m} = 2.20 \times 10^6\ \text{W}/\text{m}^2$$

Continued...

**PROBLEM 4.81 (Cont.)**

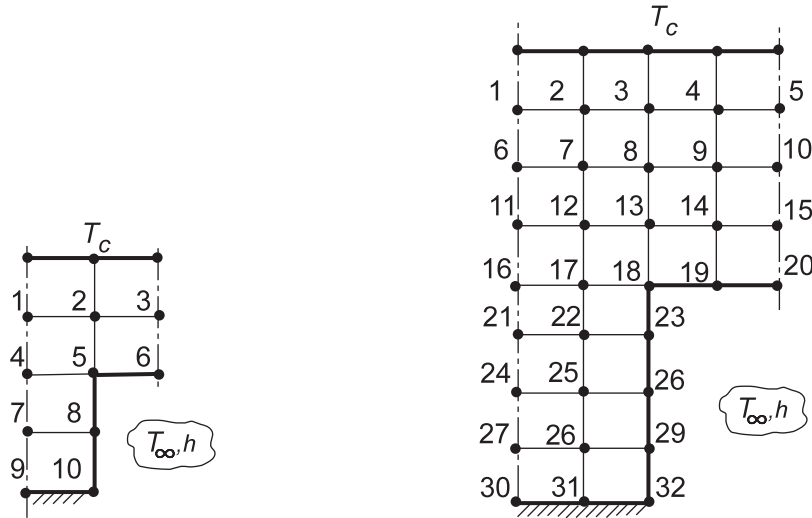

(b) To investigate the effect of grid spacing, the analysis was repeated with a spatial increment of  $50 \mu\text{m}$  (32 nodes as shown above) with the following results

$$q'_{cv} = 881 \text{ W/m} \qquad R'_{t,c-f} = 5.67 \times 10^{-2} \text{ m} \cdot \text{K/W} \qquad <$$

Using a finite-element package with a mesh around  $25 \mu\text{m}$ , we found  $R'_{t,c-f} = 5.70 \times 10^{-2} \text{ m} \cdot \text{K/W}$  which suggests the grid spacing effect is not very significant.

(c) Requiring that the overall dimensions of the symmetrical element remain unchanged, we explored what effect changes in the microchannel cross-section would have on the overall thermal resistance,  $R'_{t,c-f}$ . It is important to recognize that the sink conduction path represents the dominant resistance, since for the convection process

$$R'_{t,cv} = 1/A'_s = 1/\left(30,000 \text{ W/m}^2 \cdot \text{K} \times 600 \times 10^{-6} \text{ m}\right) = 5.55 \times 10^{-2} \text{ m} \cdot \text{K/W}$$

where  $A'_s = (w_f + 2b) = 600 \mu\text{m}$ .

Using a finite-element package, the thermal resistances per unit length for three additional channel cross-sections were determined and results summarized below.

Case	Microchannel ( $\mu\text{m}$ )	Height	Half-width	$R'_{t,c-s} \times 10^2$ (m·K/W)
A	200	100	100	5.70
B	133	150	150	6.12
C	300	100	100	4.29
D	250	150	150	4.25

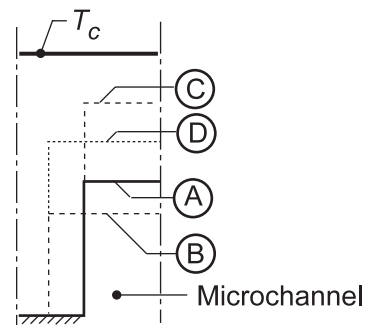

Continued...

## PROBLEM 4.81 (Cont.)

COMMENTS: (1) The IHT Workspace for the 5x5 coarse node analysis with results follows.

```

// Finite-difference equations - energy balances
// First row - treating as interior nodes considering symmetry
T1 = 0.25 * ( Tc + T2 + T4 + T2 )
T2 = 0.25 * ( Tc + T3 + T5 + T1 )
T3 = 0.25 * ( Tc + T2 + T6 + T2 )

/* Second row - Node 4 treat as interior node; for others, use Tools: Finite-Difference Equations,
Two-Dimensional, Steady-State; be sure to delimit replicated q''a = 0 equations. */
T4 = 0.25 * ( T1 + T5 + T7 + T5 )
/* Node 5: internal corner node, e-s orientation; e, w, n, s labeled 6, 4, 2, 8. */
0.0 = fd_2d_ic_es(T5,T6,T4,T2,T8,k,qdot,deltax,deltay,Tinf,h,q''a)
q''a = 0 // Applied heat flux, W/m^2; zero flux shown
/* Node 6: plane surface node, s-orientation; e, w, n labeled 5, 5, 3. */
0.0 = fd_2d_psur_s(T6,T5,T5,T3,k,qdot,deltax,deltay,Tinf,h,q''a)
//q''a = 0 // Applied heat flux, W/m^2; zero flux shown

/* Third row - Node 7 treat as interior node; for others, use Tools: Finite-Difference Equations,
Two-Dimensional, Steady-State; be sure to delimit replicated q''a = 0 equations. */
T7 = 0.25 * (T4 + T8 + T9 + T8)
/* Node 8: plane surface node, e-orientation; w, n, s labeled 7, 5, 10. */
0.0 = fd_2d_psur_e(T8,T7,T5,T10,k,qdot,deltax,deltay,Tinf,h,q''a)
//q''a = 0 // Applied heat flux, W/m^2; zero flux shown

/* Fourth row - Node 9 treat as interior node; for others, use Tools: Finite-Difference Equations,
Two-Dimensional, Steady-State; be sure to delimit replicated q''a = 0 equations. */
T9 = 0.25 * (T7 + T10 + T7 + T10)
/* Node 10: plane surface node, e-orientation; w, n, s labeled 9, 8, 8. */
0.0 = fd_2d_psur_e(T10,T9,T8,T8,k,qdot,deltax,deltay,Tinf,h,q''a)
//q''a = 0 // Applied heat flux, W/m^2; zero flux shown

// Assigned variables
// For the FDE functions,
qdot = 0 // Volumetric generation, W/m^3
deltax = deltax // Spatial increments
deltay = 100e-6 // Spatial increment, m
Tinf = 25 // Microchannel fluid temperature, C
h = 30000 // Convection coefficient, W/m^2.K
// Sink and chip parameters
k = 400 // Sink thermal conductivity, W/m.K
Tc = 75 // Maximum chip operating temperature, C
wf = 200e-6 // Channel width, m
ws = 200e-6 // Sink width, m

/* Heat rate per unit length, for two symmetrical elements about one microchannel, */
q'cv = 2 * (q'5 + q'6 + q'8 + q'10)
q'5 = h * (deltax / 2 + deltax / 2) * (T5 - Tinf)
q'6 = h * deltax / 2 * (T6 - Tinf)
q'8 = h * deltax * (T8 - Tinf)
q'10 = h * deltax / 2 * (T10 - Tinf)

/* Thermal resistance between chip and fluid, per unit channel length, */
R'tcf = (Tc - Tinf) / q'cv // Thermal resistance, m.K/W

// Total power for a chip of 10mm x 10mm, Pchip (W),
q''c = q'cv / (wf + ws) // Heat flux on chip surface, W/m^2
Pchip = Achip * q''c // Power, W
Achip = 0.01 * 0.01 // Chip area, m^2

/* Data Browser results: chip power, thermal resistance, heat rates and temperature distribution
Pchip R'tcf q''c q'cv
219.5 0.05694 2.195E6 878.1

T1 T2 T3 T4 T5 T6 T7 T8 T9 T10
74.53 74.52 74.53 74.07 74.02 74.09 73.7 73.6 73.53 73.37 */

```

## PROBLEM 4.82

**KNOWN:** Longitudinal rib ( $k = 10 \text{ W/m}\cdot\text{K}$ ) with rectangular cross-section with length  $L = 8 \text{ mm}$  and width  $w = 4 \text{ mm}$ . Base temperature  $T_b$  and convection conditions,  $T_\infty$  and  $h$ , are prescribed.

**FIND:** (a) Temperature distribution and fin base heat rate using a finite-difference method with  $\Delta x = \Delta y = 2 \text{ mm}$  for a total of  $5 \times 3 = 15$  nodal points and regions; compare results with those obtained assuming one-dimensional heat transfer in rib; and (b) The effect of grid spacing by reducing nodal spacing to  $\Delta x = \Delta y = 1 \text{ mm}$  for a total of  $9 \times 3 = 27$  nodal points and regions considering symmetry of the centerline; and (c) A criterion for which the one-dimensional approximation is reasonable; compare the heat rate for the range  $1.5 \leq L/w \leq 10$ , keeping  $L$  constant, as predicted by the two-dimensional, finite-difference method and the one-dimensional fin analysis.

**SCHEMATIC:**

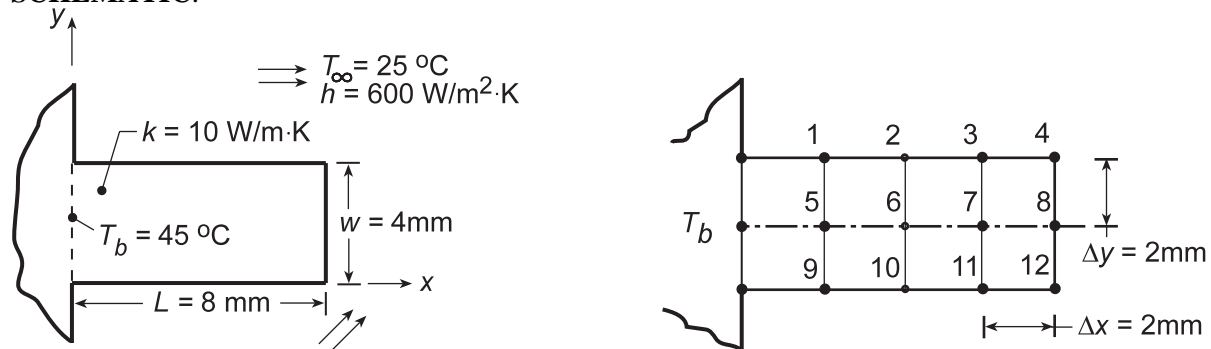

**ASSUMPTIONS:** (1) Steady-state conditions, (2) Constant properties, and (3) Convection coefficient uniform over rib surfaces, including tip.

**ANALYSIS:** (a) The rib is represented by a  $5 \times 3$  nodal grid as shown above where the symmetry plane is an adiabatic surface. The *IHT Tool, Finite-Difference Equations, for Two-Dimensional, Steady-State* conditions is used to formulate the nodal equations (see Comment 2 below) which yields the following nodal temperatures ( $^\circ\text{C}$ )

45	39.3	35.7	33.5	32.2
45	40.0	36.4	34.0	32.6
45	39.3	35.7	33.5	32.2

Note that the fin tip temperature is

$$T_{\text{tip}} = T_{12} = 32.6^\circ\text{C}$$

The fin heat rate per unit width normal to the page,  $q'_{\text{fin}}$ , can be determined from energy balances on the three base nodes as shown in the schematic below.

$$q'_{\text{fin}} = q'_a + q'_b + q'_c + q'_d + q'_e$$

$$q'_a = h(\Delta x/2)(T_b - T_\infty)$$

$$q'_b = k(\Delta y/2)(T_b - T_1)/\Delta x$$

$$q'_c = k(\Delta y)(T_b - T_5)/\Delta x$$

$$q'_d = k(\Delta y/2)(T_b - T_9)\Delta x$$

$$q'_e = h(\Delta x/2)(T_b - T_\infty)$$

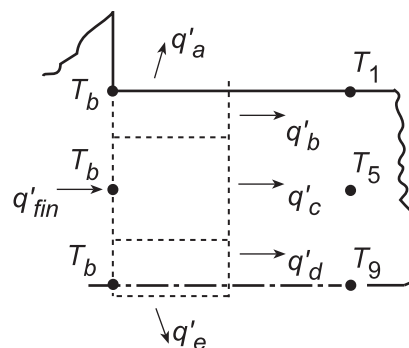

Continued...

### PROBLEM 4.82 (Cont.)

Substituting numerical values, find

$$q'_{\text{fin}} = (12.0 + 28.4 + 50.0 + 28.4 + 12.0) \text{ W/m} = 130.8 \text{ W/m} \quad <$$

Using the *IHT Model, Extended Surfaces, Heat Rate and Temperature Distributions for Rectangular, Straight Fins*, with convection tip condition, the one-dimensional fin analysis yields

$$q'_f = 131 \text{ W/m} \qquad T_{\text{tip}} = 32.2^\circ\text{C} \quad <$$

(b) With  $\Delta x = L/8 = 1 \text{ mm}$  and  $\Delta y = 1 \text{ mm}$ , for a total of  $9 \times 3 = 27$  nodal points and regions, the grid appears as shown below. Note the rib centerline is a plane of symmetry.

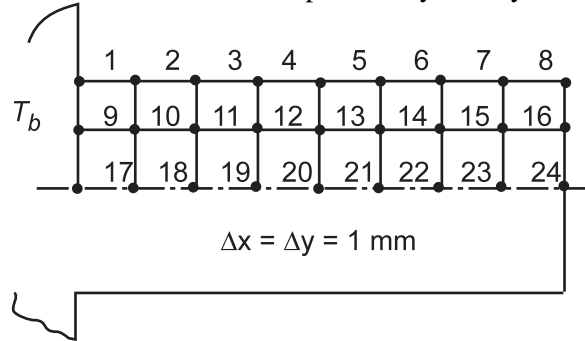

Using the same IHT FDE Tool as above with an appropriate expression for the fin heat rate, Eq. (1), the fin heat rate and tip temperature were determined.

	1-D analysis	2-D analysis (nodes)	
		(5 × 3)	(9 × 3)
$T_{\text{tip}} (^\circ\text{C})$	32.2	32.6	32.6
$q'_{\text{fin}} (\text{W/m})$	131	131	129

(c) To determine when the one-dimensional approximation is reasonable, consider a rib of constant length,  $L = 8 \text{ mm}$ , and vary the thickness  $w$  for the range  $1.5 \leq L/w \leq 10$ . Using the above IHT model for the 27 node grid, the fin heat rates for 1-D,  $q'_{1d}$ , and 2-D,  $q'_{2d}$ , analysis were determined as a function of  $w$  with the error in the approximation evaluated as

$$\text{Error}(\%) = (q'_{2d} - q'_{1d}) \times 100 / q'_{1d}$$

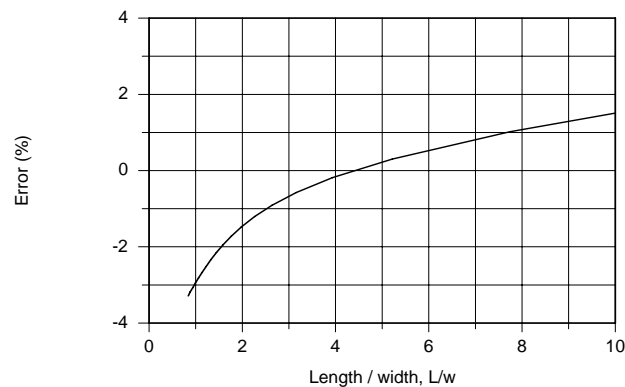

Note that for small  $L/w$ , a thick rib, the 1-D approximation is poor. For large  $L/w$ , a thin rib which approximates a fin, we would expect the 1-D approximation to become increasingly more satisfactory. The discrepancy at large  $L/w$  must be due to discretization error; that is, the grid is too coarse to accurately represent the slender rib.

### PROBLEM 4.83

**KNOWN:** Bottom half of an I-beam exposed to hot furnace gases.

**FIND:** (a) The heat transfer rate per unit length into the beam using a coarse nodal network ( $5 \times 4$ ) considering the temperature distribution across the web is uniform and (b) Assess the reasonableness of the uniform web-flange interface temperature assumption.

**SCHEMATIC:**

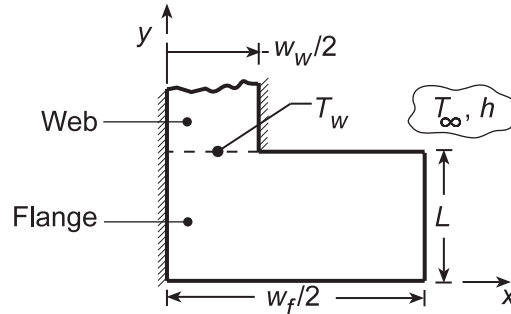

**ASSUMPTIONS:** (1) Steady-state, two-dimensional conduction, and (2) Constant properties.

**ANALYSIS:** (a) The symmetrical section of the I-beam is shown in the Schematic above indicating the web-flange interface temperature is uniform,  $T_w = 100^\circ\text{C}$ . The nodal arrangement to represent this system is shown below. The nodes on the line of symmetry have been shown for convenience in deriving the nodal finite-difference equations.

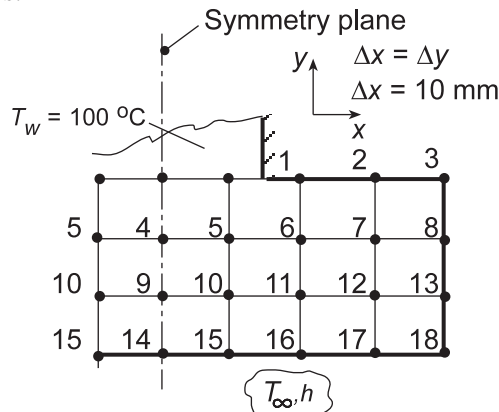

Using the *IHT Finite-Difference Equations Tool*, the set of nodal equations can be readily formulated. The temperature distribution ( $^\circ\text{C}$ ) is tabulated in the same arrangement as the nodal network.

100.00	100.00	215.8	262.9	284.8
166.6	177.1	222.4	255.0	272.0
211.7	219.5	241.9	262.7	274.4
241.4	247.2	262.9	279.3	292.9

The heat rate to the beam can be determined from energy balances about the web-flange interface nodes as shown in the sketch below.

Continued...

**PROBLEM 4.83 (Cont.)**

$$q'_w = q'_a + q'_b + q'_c$$

$$q'_w = k(\Delta y/2) \frac{T_1 - T_w}{\Delta x} + k(\Delta x) \frac{T_5 - T_w}{\Delta y} + k(\Delta x/2) \frac{T_4 - T_w}{\Delta y}$$

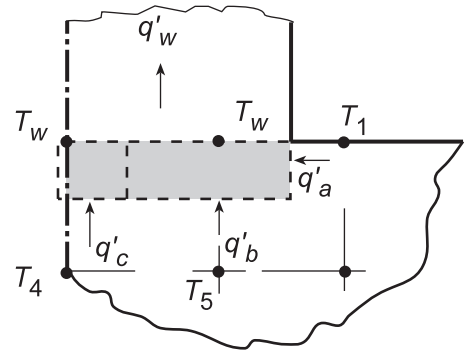

$$q'_w = 10 \text{ W/m} \cdot \text{K} [(215.8 - 100)/2 + (177.1 - 100) + (166.6 - 100)/2] \text{ K} = 1683 \text{ W/m} \quad <$$

(b) The schematic below poses the question concerning the reasonableness of the uniform temperature assumption at the web-flange interface. From the analysis above, note that  $T_1 = 215.8^\circ\text{C}$  vs.  $T_w = 100^\circ\text{C}$  indicating that this assumption is a poor one. This L-shaped section has strong two-dimensional behavior. To illustrate the effect, we performed an analysis with  $T_w = 100^\circ\text{C}$  located nearly  $2 \times$  times further up the web than it is wide. For this situation, the temperature difference at the web-flange interface across the width of the web was nearly  $40^\circ\text{C}$ . The steel beam with its low thermal conductivity has substantial internal thermal resistance and given the L-shape, the uniform temperature assumption ( $T_w$ ) across the web-flange interface is inappropriate.

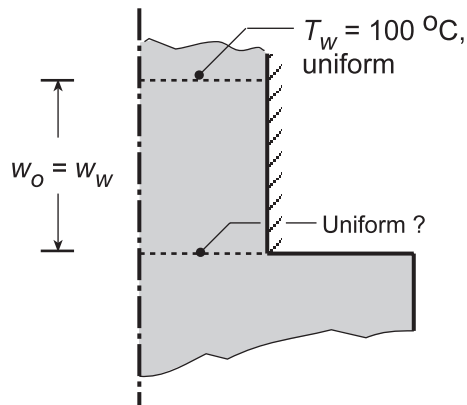

### PROBLEM 4.84

**KNOWN:** Long rectangular bar having one boundary exposed to a convection process ( $T_\infty, h$ ) while the other boundaries are maintained at a constant temperature ( $T_s$ ).

**FIND:** (a) Using a grid spacing of 30 mm and the Gauss-Seidel method, determine the nodal temperatures and the heat rate per unit length into the bar from the fluid, (b) Effect of grid spacing and convection coefficient on the temperature field.

**SCHEMATIC:**

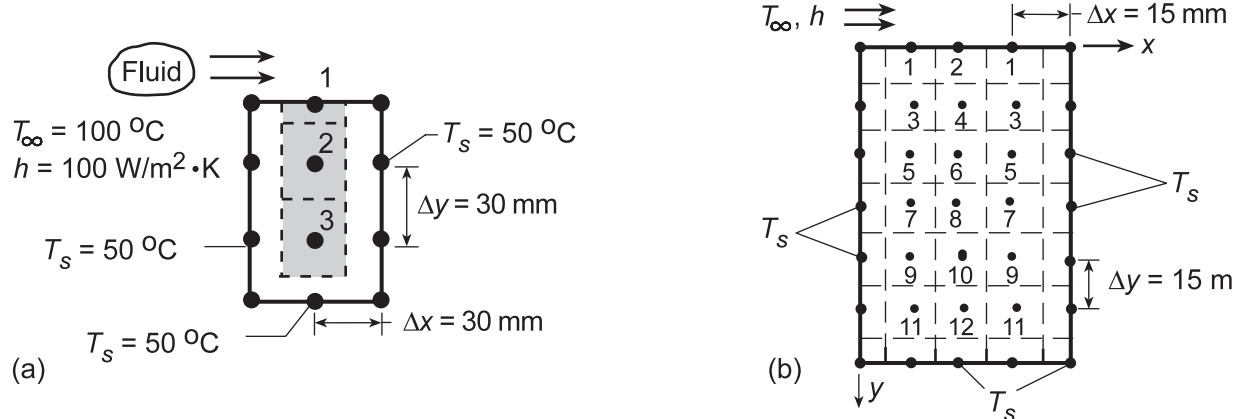

**ASSUMPTIONS:** (1) Steady-state, two-dimensional conduction, (2) Constant properties.

**ANALYSIS:** (a) With the grid spacing  $\Delta x = \Delta y = 30$  mm, three nodes are created. Using the finite-difference equations as shown in Table 4.2, but written in the form required of the Gauss-Seidel method (see Appendix D), and with  $Bi = h\Delta x/k = 100 \text{ W/m}^2 \cdot \text{K} \times 0.030 \text{ m}/1 \text{ W/m} \cdot \text{K} = 3$ , we obtain:

$$\text{Node 1: } T_1 = \frac{1}{(Bi + 2)}(T_2 + T_s + BiT_\infty) = \frac{1}{5}(T_2 + 50 + 3 \times 100) = \frac{1}{5}(T_2 + 350) \quad (1)$$

$$\text{Node 2: } T_2 = \frac{1}{4}(T_1 + 2T_s + T_3) = \frac{1}{4}(T_1 + T_3 + 2 \times 50) = \frac{1}{4}(T_1 + T_3 + 100) \quad (2)$$

$$\text{Node 3: } T_3 = \frac{1}{4}(T_2 + 3T_s) = \frac{1}{4}(T_2 + 3 \times 50) = \frac{1}{4}(T_2 + 150) \quad (3)$$

Denoting each nodal temperature with a superscript to indicate iteration step, e.g.  $T_1^k$ , calculate values as shown below.

k	$T_1$	$T_2$	$T_3$ (°C)	
0	85	60	55	← initial guess
1	82.00	59.25	52.31	
2	81.85	58.54	52.14	
3	81.71	58.46	52.12	
4	81.69	58.45	52.11	

By the 4th iteration, changes are of order  $0.02^\circ\text{C}$ , suggesting that further calculations may not be necessary.

Continued...



### PROBLEM 4.84 (Cont.)

In finite-difference form, the heat rate from the fluid to the bar is

$$q'_{\text{conv}} = h(\Delta x/2)(T_\infty - T_s) + h\Delta x(T_\infty - T_1) + h(\Delta x/2)(T_\infty - T_s)$$

$$q'_{\text{conv}} = h\Delta x(T_\infty - T_s) + h\Delta x(T_\infty - T_1) = h\Delta x[(T_\infty - T_s) + (T_\infty - T_1)]$$

$$q'_{\text{conv}} = 100 \text{ W/m}^2 \cdot \text{K} \times 0.030 \text{ m} [(100 - 50) + (100 - 81.7)]^\circ \text{C} = 205 \text{ W/m} \quad \leftarrow$$

(b) Using the *Finite-Difference Equations* option from the *Tools* portion of the IHT menu, the following two-dimensional temperature field was computed for the grid shown in schematic (b), where  $x$  and  $y$  are in mm and the temperatures are in  $^\circ\text{C}$ .

$y \backslash x$	0	15	30	45	60
0	50	80.33	85.16	80.33	50
15	50	63.58	67.73	63.58	50
30	50	56.27	58.58	56.27	50
45	50	52.91	54.07	52.91	50
60	50	51.32	51.86	51.32	50
75	50	50.51	50.72	50.51	50
90	50	50	50	50	50

The improved prediction of the temperature field has a significant influence on the heat rate, where, accounting for the symmetrical conditions,

$$q' = 2h(\Delta x/2)(T_\infty - T_s) + 2h(\Delta x)(T_\infty - T_1) + h(\Delta x)(T_\infty - T_2)$$

$$q' = h(\Delta x)[(T_\infty - T_s) + 2(T_\infty - T_1) + (T_\infty - T_2)]$$

$$q' = 100 \text{ W/m}^2 \cdot \text{K} (0.015 \text{ m}) [50 + 2(19.67) + 14.84]^\circ \text{C} = 156.3 \text{ W/m} \quad \leftarrow$$

Additional improvements in accuracy could be obtained by reducing the grid spacing to 5 mm, although the requisite number of finite-difference equations would increase from 12 to 108, significantly increasing problem *set-up* time.

An increase in  $h$  would increase temperatures everywhere within the bar, particularly at the heated surface, as well as the rate of heat transfer by convection to the surface.

**COMMENTS:** (1) Using the matrix-inversion method, the exact solution to the system of equations (1, 2, 3) of part (a) is  $T_1 = 81.70^\circ\text{C}$ ,  $T_2 = 58.44^\circ\text{C}$ , and  $T_3 = 52.12^\circ\text{C}$ . The fact that only 4 iterations were required to obtain agreement within  $0.01^\circ\text{C}$  is due to the close initial guesses.

(2) Note that the rate of heat transfer by convection to the top surface of the rod must balance the rate of heat transfer by conduction to the sides and bottom of the rod.

### PROBLEM 4.85

**KNOWN:** Long bar with trapezoidal shape, uniform temperatures on two surfaces, and two insulated surfaces.

**FIND:** Heat transfer rate per unit length using finite-difference method with space increment of 10mm.

**SCHEMATIC:**

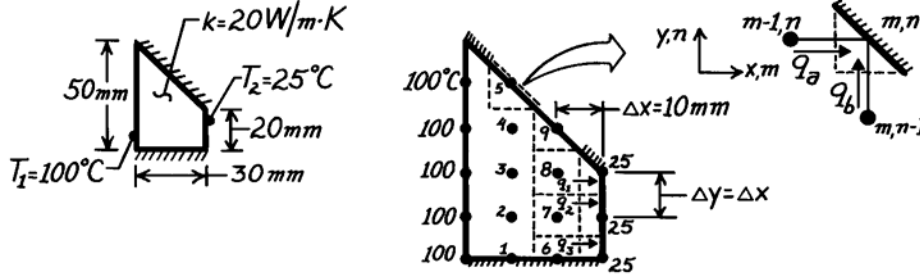

**ASSUMPTIONS:** (1) Steady-state conditions, (2) Two-dimensional conduction, (3) Constant properties.

**ANALYSIS:** The heat rate can be found after the temperature distribution has been determined. Using the nodal network shown above with  $\Delta x = 10\text{mm}$ , nine finite-difference equations must be written. Nodes 1-4 and 6-8 are interior nodes and their finite-difference equations can be written directly from Eq. 4.29. For these nodes

$$T_{m,n+1} + T_{m,n-1} + T_{m+1,n} + T_{m-1,n} - 4T_{m,n} = 0 \quad m = 1-4, 6-8. \quad (1)$$

For nodes 5 and 9 located on the diagonal, insulated boundary, the appropriate finite-difference equation follows from an energy balance on the control volume shown above (upper-right corner of schematic),  $\dot{E}_{\text{in}} - \dot{E}_{\text{out}} = q_a + q_b = 0$

$$k(\Delta y \cdot 1) \frac{T_{m-1,n} - T_{m,n}}{\Delta x} + k(\Delta x \cdot 1) \frac{T_{m,n-1} - T_{m,n}}{\Delta y} = 0.$$

Since  $\Delta x = \Delta y$ , the finite-difference equation for nodes 5 and 9 is of the form

$$T_{m-1,n} + T_{m,n-1} - 2T_{m,n} = 0 \quad m = 5,9. \quad (2)$$

The system of 9 finite-difference equations is first written in the form of Eqs. (1) or (2) and then written in explicit form for use with the Gauss-Seidel iteration method of solution; see Appendix D.

Node	Finite-difference equation	Gauss-Seidel form
1	$T_2 + T_6 + 100 - 4T_1 = 0$	$T_1 = 0.5T_2 + 0.25T_6 + 25$
2	$T_3 + T_7 + 100 - 4T_2 = 0$	$T_2 = 0.25(T_1 + T_3 + T_7) + 25$
3	$T_4 + T_8 + 100 - 4T_3 = 0$	$T_3 = 0.25(T_2 + T_4 + T_8) + 25$
4	$T_5 + T_9 + 100 - 4T_4 = 0$	$T_4 = 0.25(T_3 + T_5 + T_9) + 25$
5	$100 + T_4 - 2T_5 = 0$	$T_5 = 0.5T_4 + 50$
6	$T_7 + T_2 + 25 + T_1 - 4T_6 = 0$	$T_6 = 0.25T_1 + 0.5T_7 + 6.25$
7	$T_8 + T_6 + 25 + T_2 - 4T_7 = 0$	$T_7 = 0.25(T_2 + T_6 + T_8) + 6.25$
8	$T_9 + T_7 + 25 + T_3 - 4T_8 = 0$	$T_8 = 0.25(T_3 + T_7 + T_9) + 6.25$
9	$T_4 + T_8 - 2T_9 = 0$	$T_9 = 0.5(T_4 + T_8)$

Continued ...

### PROBLEM 4.85 (Cont.)

The iteration process begins after an initial guess ( $k = 0$ ) is made. The calculations are shown in the table below.

k	T <sub>1</sub>	T <sub>2</sub>	T <sub>3</sub>	T <sub>4</sub>	T <sub>5</sub>	T <sub>6</sub>	T <sub>7</sub>	T <sub>8</sub>	T <sub>9</sub> (°C)
0	75	75	80	85	90	50	50	60	75
1	75.0	76.3	80.0	86.3	92.5	50.0	52.5	57.5	72.5
2	75.7	76.9	80.0	86.3	93.2	51.3	52.2	57.5	71.9
3	76.3	77.0	80.2	86.3	93.2	51.3	52.7	57.3	71.9
4	76.3	77.3	80.2	86.3	93.2	51.7	52.7	57.5	71.8
5	76.6	77.3	80.3	86.3	93.2	51.7	52.9	57.4	71.9
6	76.6	77.5	80.3	86.4	93.2	51.9	52.9	57.5	71.9

Note that by the sixth iteration the change is less than 0.3°C; hence, we assume the temperature distribution is approximated by the last row of the table.

The heat rate per unit length can be determined by evaluating the heat rates in the x-direction for the control volumes about nodes 6, 7, and 8. From the schematic, find that

$$q' = q'_1 + q'_2 + q'_3$$

$$q' = k\Delta y \frac{T_8 - 25}{\Delta x} + k\Delta y \frac{T_7 - 25}{\Delta x} + k \frac{\Delta y}{2} \frac{T_6 - 25}{\Delta x}$$

Recognizing that  $\Delta x = \Delta y$  and substituting numerical values, find

$$q' = 20 \frac{\text{W}}{\text{m} \cdot \text{K}} \left[ (57.5 - 25) + (52.9 - 25) + \frac{1}{2}(51.9 - 25) \right] \text{K}$$

$$q' = 1477 \text{ W/m.} \quad \leftarrow$$

**COMMENTS:** (1) Recognize that, while the temperature distribution may have been determined to a reasonable approximation, the uncertainty in the heat rate could be substantial. This follows since the heat rate is based upon a gradient and hence on temperature differences.

(2) Note that the initial guesses ( $k = 0$ ) for the iteration are within 5°C of the final distribution. The geometry is simple enough that the guess can be very close. In some instances, a flux plot may be helpful and save labor in the calculation.

(3) In writing the FDEs, the iteration index (superscript  $k$ ) was not included to simplify expression of the equations. However, the most recent value of  $T_{m,n}$  is always used in the computations. Note that this system of FDEs is diagonally dominant and no rearrangement is required.

## PROBLEM 4.86

**KNOWN:** Electrical heating elements with known dissipation rate embedded in a ceramic plate of known thermal conductivity; lower surface is insulated, while upper surface is exposed to a convection process.

**FIND:** (a) Temperature distribution within the plate using prescribed grid spacing, (b) Sketch isotherms to illustrate temperature distribution, (c) Heat loss by convection from exposed surface (compare with element dissipation rate), (d) Advantage, if any, in not setting  $\Delta x = \Delta y$ , (e) Effect of grid size and convection coefficient on the temperature field.

**SCHEMATIC:**

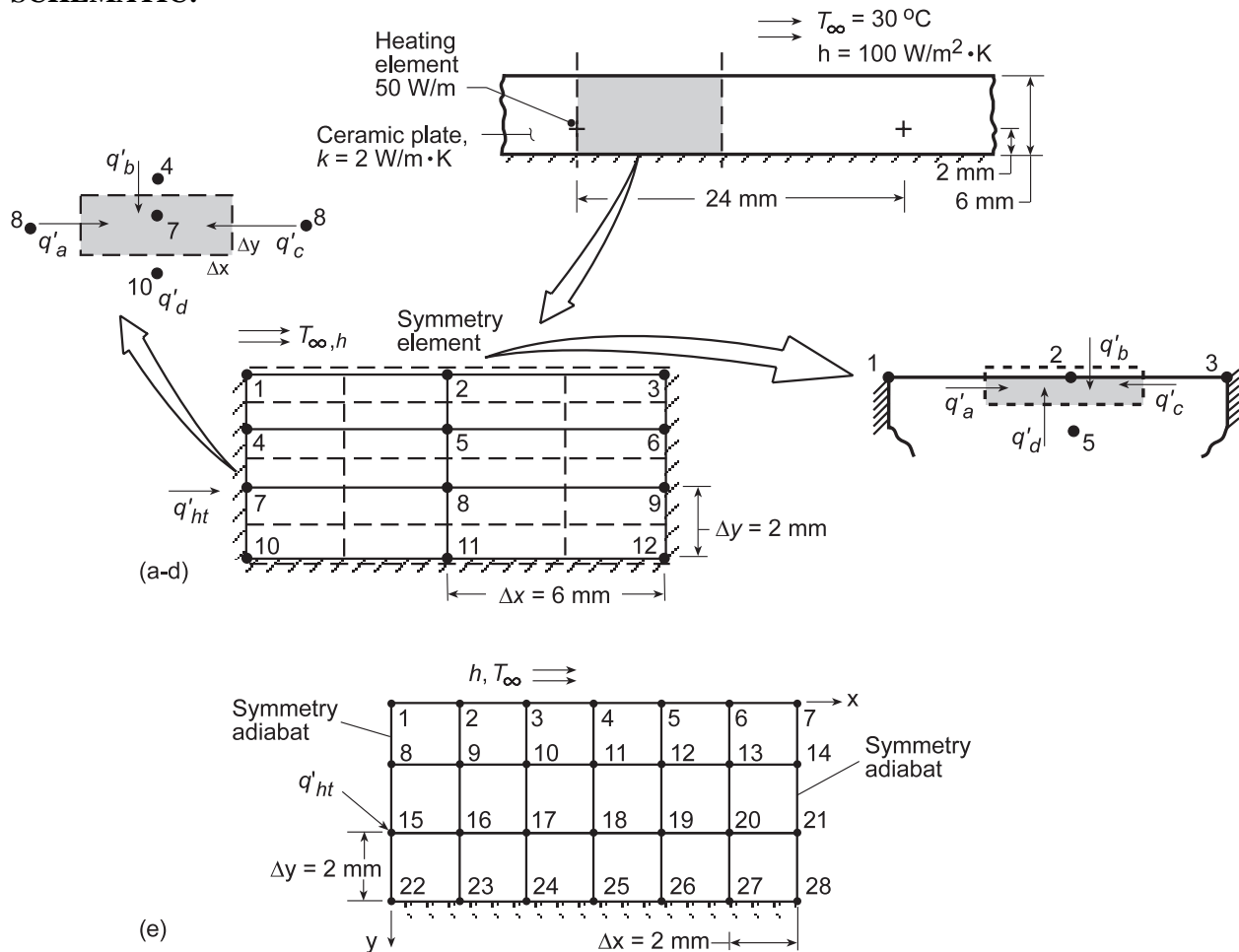

**ASSUMPTIONS:** (1) Steady-state, two-dimensional conduction in ceramic plate, (2) Constant properties, (3) No internal generation, except for Node 7 (or Node 15 for part (e)), (4) Heating element approximates a line source of negligible wire diameter.

**ANALYSIS:** (a) The prescribed grid for the symmetry element shown above consists of 12 nodal points. Nodes 1-3 are points on a surface experiencing convection; nodes 4-6 and 8-12 are interior nodes. Node 7 is a special case of the interior node having a generation term; because of symmetry,  $q'_{ht} = 25\text{ W/m}$ . The finite-difference equations are derived as follows:

Continued...

### PROBLEM 4.86 (Cont.)

*Surface Node 2.* From an energy balance on the prescribed control volume with  $\Delta x/\Delta y = 3$ ,

$$\dot{E}'_{in} - \dot{E}'_{out} = q'_a + q'_b + q'_c + q'_d = 0;$$

$$k \frac{\Delta y}{2} \frac{T_1 - T_2}{\Delta x} + h\Delta x (T_\infty - T_2) + k \frac{\Delta y}{2} \frac{T_3 - T_2}{\Delta x} + k\Delta x \frac{T_5 - T_2}{\Delta y} = 0.$$

Regrouping, find

$$T_2 \left[ 1 + 2N \frac{\Delta x}{\Delta y} + 1 + 2 \left( \frac{\Delta x}{\Delta y} \right)^2 \right] = T_1 + T_3 + 2 \left( \frac{\Delta x}{\Delta y} \right)^2 T_5 + 2N \frac{\Delta x}{\Delta y} T_\infty$$

where  $N = h\Delta x/k = 100 \text{ W/m}^2 \cdot \text{K} \times 0.006 \text{ m} / 2 \text{ W/m} \cdot \text{K} = 0.30 \text{ K}$ . Hence, with  $T_\infty = 30^\circ\text{C}$ ,

$$T_2 = 0.04587T_1 + 0.04587T_3 + 0.82569T_5 + 2.4771 \quad (1)$$

From this FDE, the forms for nodes 1 and 3 can also be deduced.

*Interior Node 7.* From an energy balance on the prescribed control volume, with  $\Delta x/\Delta y = 3$ ,

$$\dot{E}'_{in} - \dot{E}'_g = 0, \text{ where } \dot{E}'_g = 2q'_{ht} \text{ and } \dot{E}'_{in} \text{ represents the conduction terms. Hence,}$$

$$q'_a + q'_b + q'_c + q'_d + 2q'_{ht} = 0, \text{ or}$$

$$k\Delta y \frac{T_8 - T_7}{\Delta x} + k\Delta x \frac{T_4 - T_7}{\Delta y} + k\Delta y \frac{T_8 - T_7}{\Delta x} + k\Delta x \frac{T_{10} - T_7}{\Delta y} + 2q'_{ht} = 0$$

Regrouping,

$$T_7 \left[ 1 + \left( \frac{\Delta x}{\Delta y} \right)^2 + 1 + \left( \frac{\Delta x}{\Delta y} \right)^2 \right] = T_8 + \left( \frac{\Delta x}{\Delta y} \right)^2 T_4 + T_8 + \left( \frac{\Delta x}{\Delta y} \right)^2 T_{10} + \frac{2q'_{ht}}{k} \left( \frac{\Delta x}{\Delta y} \right)$$

Recognizing that  $\Delta x/\Delta y = 3$ ,  $q'_{ht} = 25 \text{ W/m}$  and  $k = 2 \text{ W/m} \cdot \text{K}$ , the FDE is

$$T_7 = 0.0500T_8 + 0.4500T_4 + 0.0500T_8 + 0.4500T_{10} + 3.7500 \quad (2)$$

The FDEs for the remaining nodes may be deduced from this form. Following the procedure described in Appendix D for the Gauss-Seidel method, the system of FDEs has the form:

$$T_1^k = 0.09174T_2^{k-1} + 0.8257T_4^{k-1} + 2.4771$$

$$T_2^k = 0.04587T_1^k + 0.04587T_3^{k-1} + 0.8257T_5^{k-1} + 2.4771$$

$$T_3^k = 0.09174T_2^k + 0.8257T_6^{k-1} + 2.4771$$

$$T_4^k = 0.4500T_1^k + 0.1000T_5^{k-1} + 0.4500T_7^{k-1}$$

$$T_5^k = 0.4500T_2^k + 0.0500T_4^k + 0.0500T_6^{k-1} + 0.4500T_8^{k-1}$$

$$T_6^k = 0.4500T_3^k + 0.1000T_5^k + 0.4500T_9^{k-1}$$

$$T_7^k = 0.4500T_4^k + 0.1000T_8^{k-1} + 0.4500T_{10}^{k-1} + 3.7500$$

$$T_8^k = 0.4500T_5^k + 0.0500T_7^k + 0.0500T_9^{k-1} + 0.4500T_{11}^{k-1}$$

$$T_9^k = 0.4500T_6^k + 0.1000T_8^k + 0.4500T_{12}^{k-1}$$

$$T_{10}^k = 0.9000T_7^k + 0.1000T_{11}^{k-1}$$

$$T_{11}^k = 0.9000T_8^k + 0.0500T_{10}^{k-1} + 0.0500T_{12}^{k-1}$$

$$T_{12}^k = 0.9000T_9^k + 0.1000T_{11}^k$$

Continued ...

### PROBLEM 4.86 (Cont.)

Note the use of the superscript  $k$  to denote the level of iteration. Begin the iteration procedure with rational estimates for  $T_i$  ( $k = 0$ ) and prescribe the convergence criterion as  $\varepsilon \leq 0.1$  K.

$k/T_i$	1	2	3	4	5	6	7	8	9	10	11	12
0	55.0	50.0	45.0	61.0	54.0	47.0	65.0	56.0	49.0	60.0	55.0	50.0
1	57.4	51.7	46.0	60.4	53.8	48.1	63.5	54.6	49.6	62.7	54.8	50.1
2	57.1	51.6	46.9	59.7	53.2	48.7	64.3	54.3	49.9	63.4	54.5	50.4
$\infty$	55.80	49.93	47.67	59.03	51.72	49.19	63.89	52.98	50.14	62.84	53.35	50.46

The last row with  $k = \infty$  corresponds to the solution obtained by matrix inversion. It appears that at least 20 iterations would be required to satisfy the convergence criterion using the Gauss-Seidel method.

(b) Selected isotherms are shown in the sketch of the nodal network.

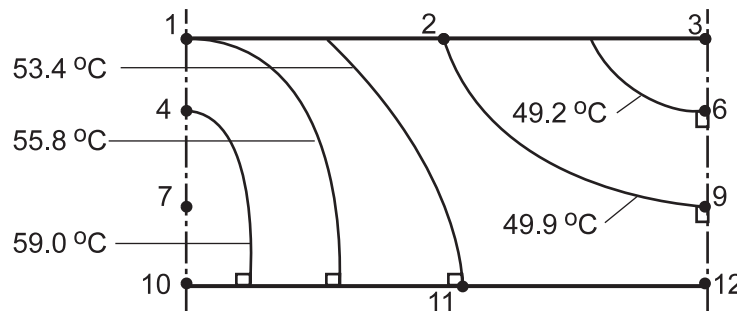

Note that the isotherms are normal to the adiabatic surfaces.

(c) The heat loss by convection can be expressed as

$$q'_{\text{conv}} = h \left[ \frac{1}{2} \Delta x (T_1 - T_\infty) + \Delta x (T_2 - T_\infty) + \frac{1}{2} \Delta x (T_3 - T_\infty) \right]$$

$$q'_{\text{conv}} = 100 \text{ W/m}^2 \cdot \text{K} \times 0.006 \text{ m} \left[ \frac{1}{2} (55.80 - 30) + (49.93 - 30) + \frac{1}{2} (47.67 - 30) \right] = 25.00 \text{ W/m} \quad \leftarrow$$

As expected, the heat loss by convection is equal to the heater element dissipation. This follows from the conservation of energy requirement.

(d) For this situation, choosing  $\Delta x = 3\Delta y$  was advantageous from the standpoint of precision and effort. If we had chosen  $\Delta x = \Delta y = 2$  mm, there would have been 28 nodes, doubling the amount of work, but with improved precision.

(e) Examining the effect of grid size by using the *Finite-Difference Equations* option from the *Tools* portion of the IHT Menu, the following temperature field was computed for  $\Delta x = \Delta y = 2$  mm, where  $x$  and  $y$  are in mm and the temperatures are in  $^\circ\text{C}$ .

$y \backslash x$	0	2	4	6	8	10	12
0	55.04	53.88	52.03	50.32	49.02	48.24	47.97
2	58.71	56.61	54.17	52.14	50.67	49.80	49.51
4	66.56	59.70	55.90	53.39	51.73	50.77	50.46
6	63.14	59.71	56.33	53.80	52.09	51.11	50.78

Continued ...

### PROBLEM 4.86 (Cont.)

Agreement with the results of part (a) is excellent, except in proximity to the heating element, where  $T_{15} = 66.6^\circ\text{C}$  for the fine grid exceeds  $T_7 = 63.9^\circ\text{C}$  for the coarse grid by  $2.7^\circ\text{C}$ .

For  $h = 10 \text{ W/m}^2\cdot\text{K}$ , the maximum temperature in the ceramic corresponds to  $T_{15} = 254^\circ\text{C}$ , and the heater could still be operated at the prescribed power. With  $h = 10 \text{ W/m}^2\cdot\text{K}$ , the critical temperature of  $T_{15} = 400^\circ\text{C}$  would be reached with a heater power of approximately  $82 \text{ W/m}$ .

**COMMENTS:** (1) The method used to obtain the rational estimates for  $T_i$  ( $k = 0$ ) in part (a) is as follows. Assume  $25 \text{ W/m}$  is transferred by convection uniformly over the surface; find  $\bar{T}_{\text{surf}} \approx 50^\circ\text{C}$ . Set  $T_2 = 50^\circ\text{C}$  and recognize that  $T_1$  and  $T_3$  will be higher and lower, respectively. Assume  $25 \text{ W/m}$  is conducted uniformly to the outer nodes; find  $T_5 - T_2 \approx 4^\circ\text{C}$ . For the remaining nodes, use intuition to guess reasonable values. (2) In selecting grid size (and whether  $\Delta x = \Delta y$ ), one should consider the region of largest temperature gradients. Predicted values of the maximum temperature in the ceramic will be very sensitive to the grid resolution.

**NOTE TO INSTRUCTOR:** Although the problem statement calls for calculations with  $\Delta x = \Delta y = 1 \text{ mm}$ , the instructional value and benefit-to-effort ratio are small. Hence, consideration of this grid size is not recommended.

### PROBLEM 4.87

**KNOWN:** Straight fin of uniform cross section with prescribed thermal conditions and geometry; tip condition allows for convection.

**FIND:** (a) Calculate the fin heat rate,  $q'_f$ , and tip temperature,  $T_L$ , assuming one-dimensional heat transfer in the fin; calculate the Biot number to determine whether the one-dimensional assumption is valid, (b) Using the finite-element software FEHT, perform a two-dimensional analysis to determine the fin heat rate and the tip temperature; display the isotherms; describe the temperature field and the heat flow pattern inferred from the display, and (c) Validate your FEHT code against the 1-D analytical solution for a fin using a thermal conductivity of 50 and 500 W/m·K.

**SCHEMATIC:**

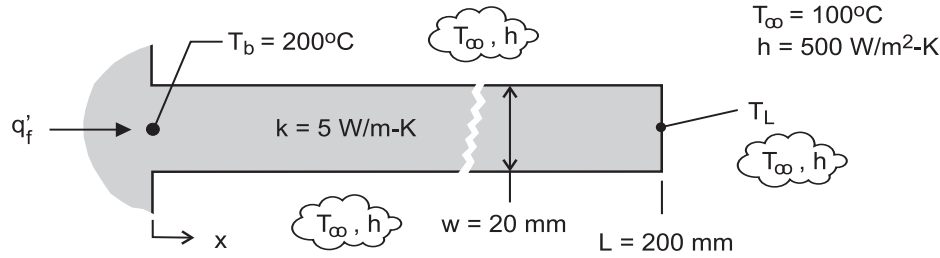

**ASSUMPTIONS:** (1) Steady-state conduction with constant properties, (2) Negligible radiation exchange, (3) Uniform convection coefficient.

**ANALYSIS:** (a) Assuming one-dimensional conduction,  $q'_L$  and  $T_L$  can be determined using Eqs. 3.77 and 3.75, respectively, from Table 3.4, Case A. Alternatively, use the IHT Model / Extended Surfaces / Temperature Distribution and Heat Rate / Straight Fin / Rectangular. These results are tabulated below and labeled as “1-D.” The Biot number for the fin is

$$Bi = \frac{h(t/2)}{k} = \frac{500 \text{ W/m}^2 \cdot \text{K} (0.020 \text{ m}/2)}{5 \text{ W/m} \cdot \text{K}} = 1$$

(b, c) The fin can be drawn as a two-dimensional outline in FEHT with convection boundary conditions on the exposed surfaces, and with a uniform temperature on the base. Using a fine mesh (at least 1280 elements), solve for the temperature distribution and use the *View / Temperature Contours* command to view the isotherms and the *Heat Flow* command to determine the heat rate into the fin base. The results of the analysis are summarized in the table below.

k (W/m·K)	Bi	Tip temperature, $T_L$ (°C)		Fin heat rate, $q'_f$ (W/m)		Difference* (%)
		1-D	2-D	1-D	2-D	
5	1	100	100	1010	805	20
50	0.1	100.3	100	3194	2990	6.4
500	0.01	123.8	124	9812	9563	2.5

$$* \text{ Difference} = (q'_{f,1D} - q'_{f,2D}) \times 100 / q'_{f,1D}$$

**COMMENTS:** (1) From part (a), since  $Bi = 1 > 0.1$ , the internal conduction resistance is not negligible. Therefore significant transverse temperature gradients exist, and the one-dimensional conduction assumption in the fin is a poor one.

Continued ...



### PROBLEM 4.87 (Cont.)

(2) From the table, with  $k = 5 \text{ W/m}\cdot\text{K}$  ( $Bi = 1$ ), the 2-D fin heat rate obtained from the FEA analysis is 20% lower than that for the 1-D analytical analysis. This is as expected since the 2-D model accounts for transverse thermal resistance to heat flow. Note, however, that analyses predict the same tip temperature, a consequence of the fin approximating an infinitely long fin ( $mL = 20.2 \gg 2.56$ ; see Ex. 3.8 Comments).

(3) For the  $k = 5 \text{ W/m}\cdot\text{K}$  case, the FEHT isotherms show considerable curvature in the region near the fin base. For example, at  $x = 10$  and  $20 \text{ mm}$ , the difference between the centerline and surface temperatures are  $15$  and  $7^\circ\text{C}$ .

(4) From the table, with increasing thermal conductivity, note that  $Bi$  decreases, and the one-dimensional heat transfer assumption becomes more appropriate. The difference for the case when  $k = 500 \text{ W/m}\cdot\text{K}$  is mostly due to the approximate manner in which the heat rate is calculated in the FEA software.

## PROBLEM 4.88

**KNOWN:** Long rectangular bar having one boundary exposed to a convection process ( $T_\infty$ ,  $h$ ) while the other boundaries are maintained at constant temperature  $T_s$ .

**FIND:** Using the finite-element method of FEHT, (a) Determine the temperature distribution, plot the isotherms, and identify significant features of the distribution, (b) Calculate the heat rate per unit length (W/m) into the bar from the air stream, and (c) Explore the effect on the heat rate of increasing the convection coefficient by factors of two and three; explain why the change in the heat rate is not proportional to the change in the convection coefficient.

**SCHEMATIC:**

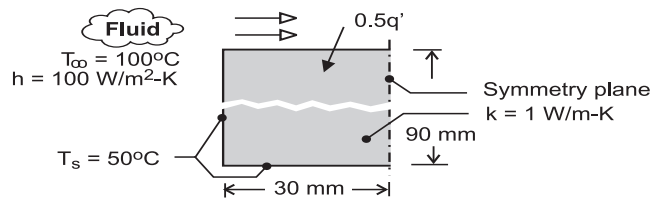

**ASSUMPTIONS:** (1) Steady-state, two dimensional conduction, (2) Constant properties.

**ANALYSIS:** (a) The symmetrical section shown in the schematic is drawn in FEHT with the specified boundary conditions and material property. The *View | Temperature Contours* command is used to represent ten isotherms (isopotentials) that have minimum and maximum values of 53.9°C and 85.9°C, respectively.

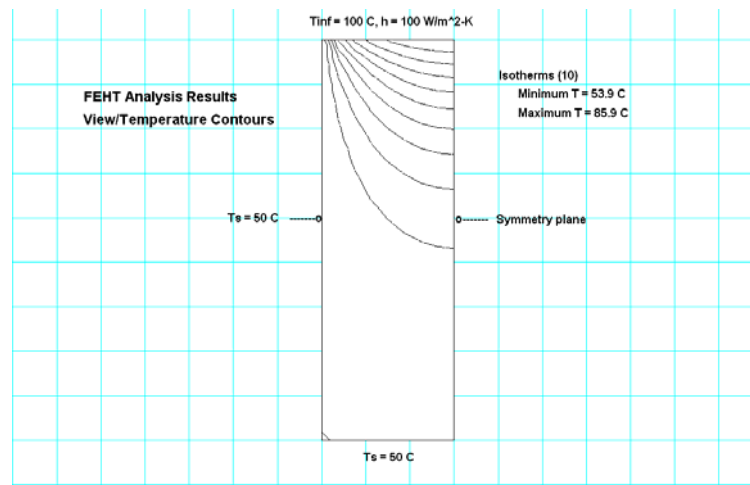

Because of the symmetry boundary condition, the isotherms are normal to the center-plane indicating an adiabatic surface. Note that the temperature change along the upper surface of the bar is substantial ( $\approx 40^\circ\text{C}$ ), whereas the lower half of the bar has less than a  $3^\circ\text{C}$  change. That is, the lower half of the bar is largely unaffected by the heat transfer conditions at the upper surface.

(b, c) Using the *View | Heat Flows* command considering the upper surface boundary with selected convection coefficients, the heat rates into the bar from the air stream were calculated.

$h \left( \text{W} / \text{m}^2 \cdot \text{K} \right)$	100	200	300
$q' \left( \text{W} / \text{m} \right)$	128	175	206

Increasing the convection coefficient by factors of 2 and 3, increases the heat rate by 37% and 61%, respectively. The heat rate from the bar to the air stream is controlled by the thermal resistances of the bar (conduction) and the convection process. Since the conduction resistance is significant, we should not expect the heat rate to change proportionally to the change in convection resistance.

## PROBLEM 4.89

**KNOWN:** Log rod of rectangular cross-section of Problem 4.53 that experiences uniform heat generation while its surfaces are maintained at a fixed temperature. Use the finite-element software FEHT as your analysis tool.

**FIND:** (a) Represent the temperature distribution with representative isotherms; identify significant features; and (b) Determine what heat generation rate will cause the midpoint to reach 600 K with unchanged boundary conditions.

**SCHEMATIC:**

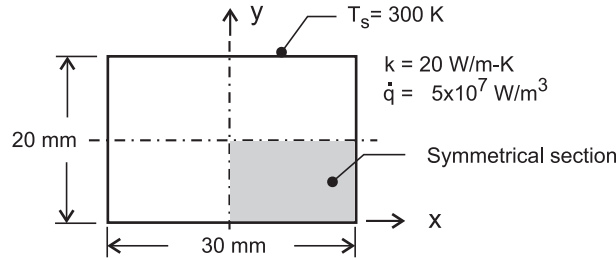

**ASSUMPTIONS:** (1) Steady-state conditions, and (2) Two-dimensional conduction with constant properties.

**ANALYSIS:** (a) Using *FEHT*, do the following: in *Setup*, enter an appropriate scale; *Draw* the outline of the symmetrical section shown in the above schematic; *Specify* the *Boundary Conditions* (zero heat flux or adiabatic along the symmetrical lines, and isothermal on the edges). Also *Specify* the *Material Properties* and *Generation* rate. *Draw* three *Element Lines* as shown on the annotated version of the *FEHT* screen below. To reduce the mesh, hit *Draw/Reduce Mesh* until the desired fineness is achieved (256 elements is a good choice).

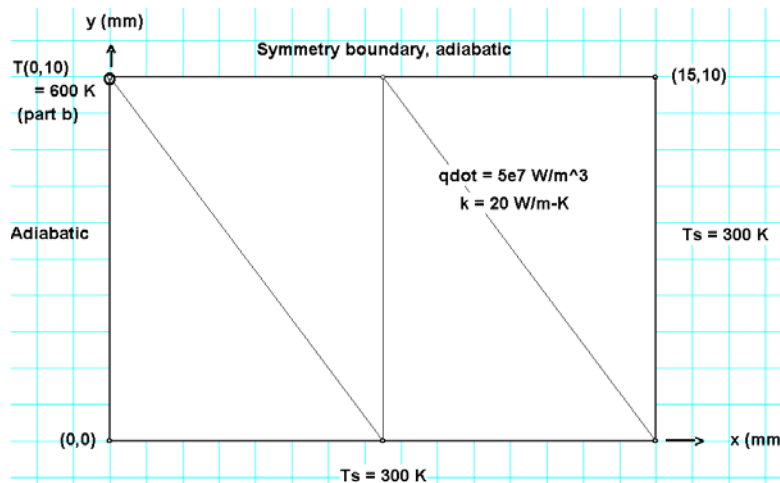

Continued ...

### PROBLEM 4.89 (Cont.)

After hitting *Run*, *Check* and then *Calculate*, use the *View/Temperature Contours* and select the 10-isopotential option to display the isotherms as shown in an annotated copy of the *FEHT* screen below.

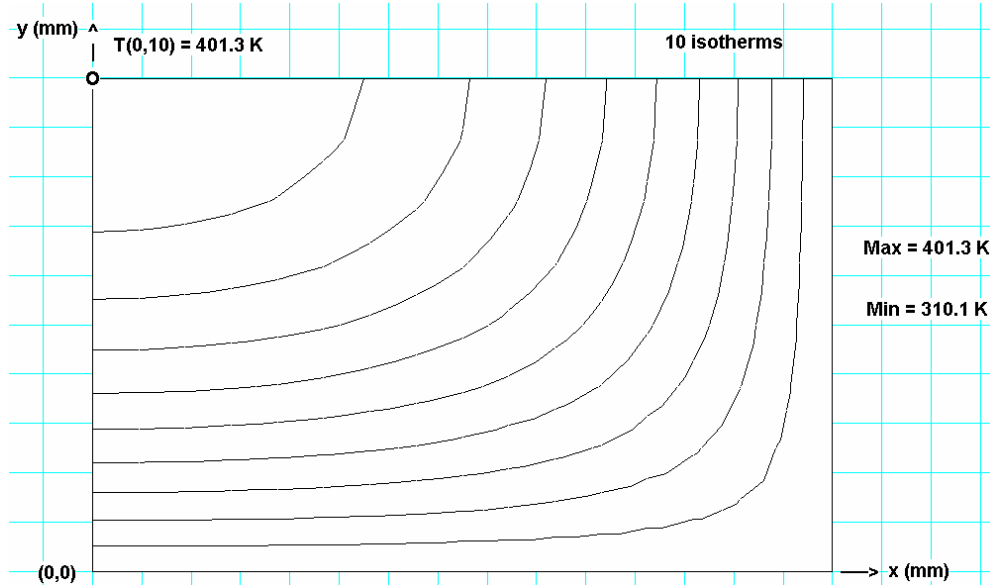

The isotherms are normal to the symmetrical lines as expected since those surfaces are adiabatic. The isotherms, especially near the center, have an elliptical shape. Along the  $x = 0$  axis and the  $y = 10$  mm axis, the temperature gradient is nearly linear. The hottest point is of course the center for which the temperature is

$$(T(0, 10 \text{ mm}) = 401.3 \text{ K.})$$

<

The temperature of this point can be read using the *View/Temperatures* or *View/Tabular Output* command.

(b) To determine the required generation rate so that  $T(0, 10 \text{ mm}) = 600 \text{ K}$ , it is necessary to re-run the model with several guessed values of  $\dot{q}$ . After a few trials, find

$$\dot{q} = 1.48 \times 10^8 \text{ W/m}^3$$

<

## PROBLEM 4.90

**KNOWN:** Symmetrical section of a flow channel with prescribed values of  $\dot{q}$  and  $k$ , as well as the surface convection conditions. See Problem 4.57.

**FIND:** Using the finite-element method of FEHT, (a) Determine the temperature distribution and plot the isotherms; identify the coolest and hottest regions, and the region with steepest gradients; describe the heat flow field, (b) Calculate the heat rate per unit length (W/m) from the outer surface A to the adjacent fluid, (c) Calculate the heat rate per unit length (W/m) to surface B from the inner fluid, and (d) Verify that the results are consistent with an overall energy balance on the section.

**SCHEMATIC:**

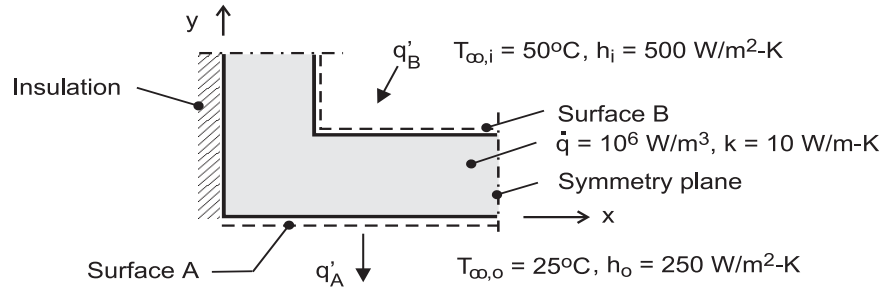

**ASSUMPTIONS:** (1) Steady-state, two-dimensional conduction, (2) Constant properties.

**ANALYSIS:** (a) The symmetrical section shown in the schematic is drawn in FEHT with the specified boundary conditions, material property and generation. The *View | Temperature Contours* command is used to represent ten isotherms (isopotentials) that have minimum and maximum values of 82.1°C and 125.2°C.

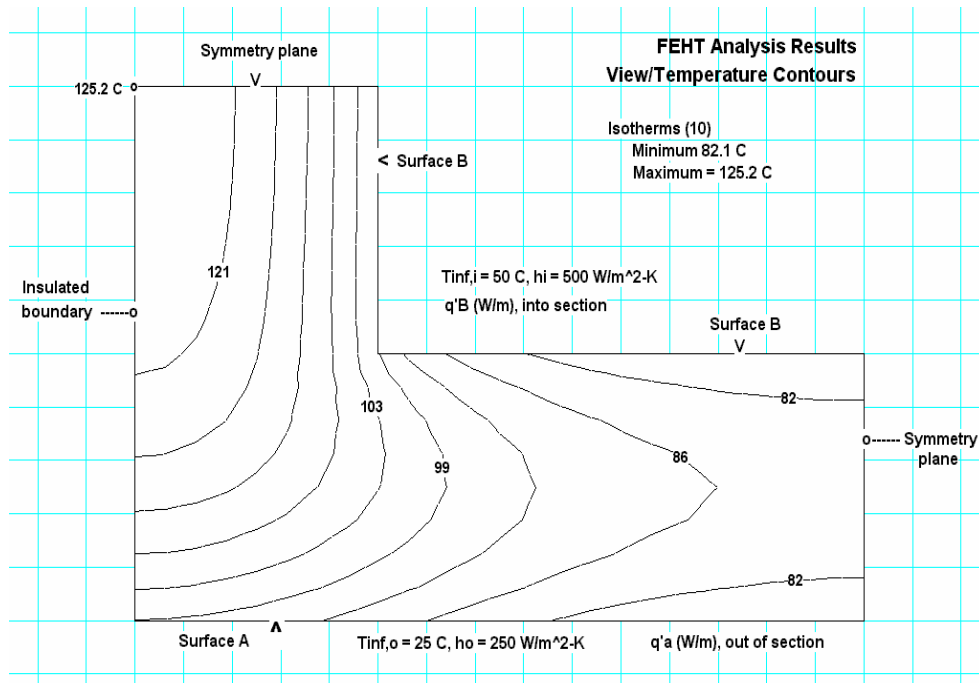

The hottest region of the section is the upper vertical leg (left-hand corner). The coolest region is in the lower horizontal leg at the far right-hand boundary. The maximum and minimum section temperatures (125°C and 77°C), respectively, are higher than either adjoining fluid. Remembering that heat flow lines are normal to the isotherms, heat flows from the hottest corner directly to the inner fluid and downward into the lower leg and then flows out surface A and the lower portion of surface B.

Continued ...

### PROBLEM 4.90 (Cont.)

(b, c) Using the *View | Heat Flows* command considering the boundaries for surfaces A and B, the heat rates are:

$$q'_s = 1135 \text{ W/m} \qquad q'_B = -1365 \text{ W/m.} \qquad <$$

From an energy balance on the section, we note that the results are consistent since conservation of energy is satisfied.

$$\dot{E}'_{\text{in}} - \dot{E}'_{\text{out}} + \dot{E}'_g = 0$$

$$-q'_A + q'_B + \dot{q}'_V = 0$$

$$-1135 \text{ W/m} + (-1365 \text{ W/m}) + 2500 \text{ W/m} = 0 \qquad <$$

where  $\dot{q}'_V = 1 \times 10^6 \text{ W/m}^3 \times [25 \times 50 + 25 \times 50] \times 10^{-6} \text{ m}^2 = 2500 \text{ W/m}$ .

**COMMENTS:** (1) For background on setting up this problem in FEHT, see the tutorial example of the User's Manual. While the boundary conditions are different, and the internal generation term is to be included, the procedure for performing the analysis is the same.

(2) The heat flow distribution can be visualized using the *View | Temperature Gradients* command. The direction and magnitude of the heat flow is represented by the directions and lengths of arrows. Compare the heat flow distribution to the isotherms shown above.

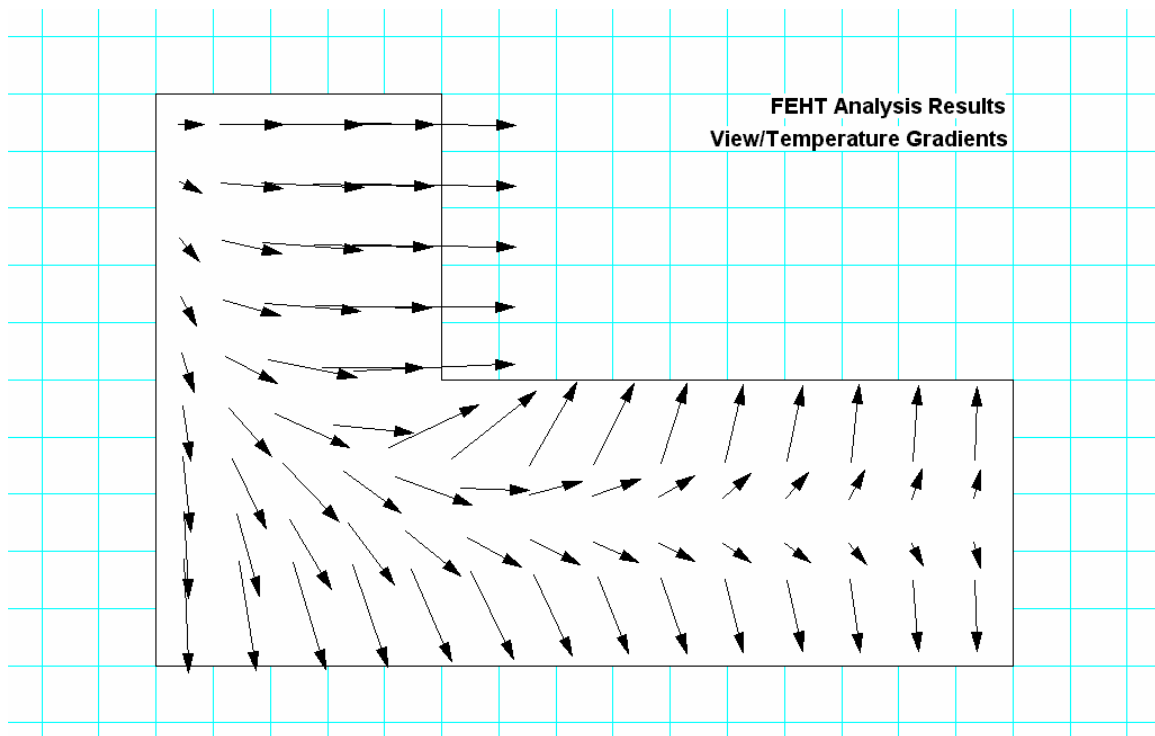

### PROBLEM 4.91

**KNOWN:** Hot-film flux gage for determining the convection coefficient of an adjoining fluid stream by measuring the dissipated electric power,  $P_e$ , and the average surface temperature,  $T_{s,f}$ .

**FIND:** Using the finite-element method of *FEHT*, determine the fraction of the power dissipation that is conducted into the quartz substrate considering three cases corresponding to convection coefficients of 500, 1000 and 2000  $\text{W}/\text{m}^2\cdot\text{K}$ .

**SCHEMATIC:**

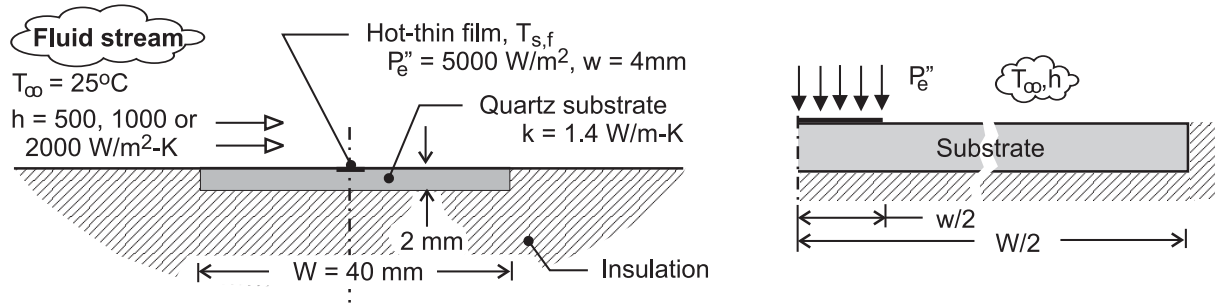

**ASSUMPTIONS:** (1) Steady-state, two-dimensional conduction, (2) Constant substrate properties, (3) Uniform convection coefficient over the hot-film and substrate surfaces, (4) Uniform power dissipation over hot film.

**ANALYSIS:** The symmetrical section shown in the schematic above (right) is drawn into *FEHT* specifying the substrate material property. On the upper surface, a convection boundary condition

$(T_{\infty}, h)$  is specified over the full width  $W/2$ . Additionally, an applied uniform flux  $(P_e'', \text{W}/\text{m}^2)$

boundary condition is specified for the hot-film region ( $w/2$ ). The remaining surfaces of the two-dimensional system are specified as adiabatic. In the schematic below, the electrical power dissipation  $P_e'$  ( $\text{W}/\text{m}$ ) in the hot film is transferred by convection from the film surface,  $q'_{cv,f}$ , and from the adjacent substrate surface,  $q'_{cv,s}$ .

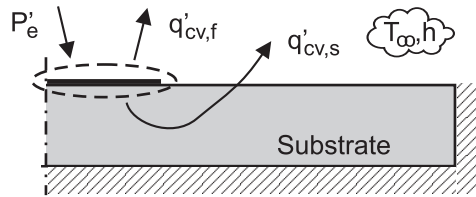

The analysis evaluates the fraction,  $F$ , of the dissipated electrical power that is conducted into the substrate and convected to the fluid stream,

$$F = q'_{cv,s} / P_e' = 1 - q'_{cv,f} / P_e'$$

where  $P_e' = P_e'' (w/2) = 5000 \text{ W}/\text{m}^2 \times (0.002 \text{ m}) = 10 \text{ W}/\text{m}$ .

After solving for the temperature distribution, the *View/Heat Flow* command is used to evaluate  $q'_{cv,f}$  for the three values of the convection coefficient.

Continued ...

### PROBLEM 4.91 (Cont.)

Case	$h(\text{W}/\text{m}^2 \cdot \text{K})$	$q'_{\text{cv},f} (\text{W}/\text{m})$	F(%)	$T_{\text{s},f} (\text{°C})$
1	500	5.64	43.6	30.9
2	1000	6.74	32.6	28.6
3	2000	7.70	23.3	27.0

**COMMENTS:** (1) For the ideal hot-film flux gage, there is negligible heat transfer to the substrate, and the convection coefficient of the air stream is calculated from the measured electrical power,  $P_e''$ , the average film temperature (by a thin-film thermocouple),  $T_{\text{s},f}$ , and the fluid stream temperature,  $T_\infty$ , as  $h = P_e'' / (T_{\text{s},f} - T_\infty)$ . The purpose in performing the present analysis is to estimate a correction factor to account for heat transfer to the substrate.

(2) As anticipated, the fraction of the dissipated electrical power conducted into the substrate,  $F$ , decreases with increasing convection coefficient. For the case of the largest convection coefficient,  $F$  amounts to 25%, making it necessary to develop a reliable, accurate heat transfer model to estimate the applied correction. Further, this condition limits the usefulness of this gage design to flows with high convection coefficients.

(3) A reduction in  $F$ , and hence the effect of an applied correction, could be achieved with a substrate material having a lower thermal conductivity than quartz. However, quartz is a common substrate material for fabrication of thin-film heat-flux gages and thermocouples. By what other means could you reduce  $F$ ?

(4) In addition to the tutorial example in the *FEHT* User's Manual, the solved models for Examples 4.3 and 4.4 are useful for developing skills helpful in solving this problem.



### PROBLEM 4.92

**KNOWN:** Flue of square cross section with prescribed geometry, thermal conductivity and inner and outer surface convective conditions.

**FIND:** (a) Heat loss per unit length,  $q'$ , by convection to the air, (b) Effect of grid spacing and convection coefficients on temperature field; show isotherms.

**SCHEMATIC:**

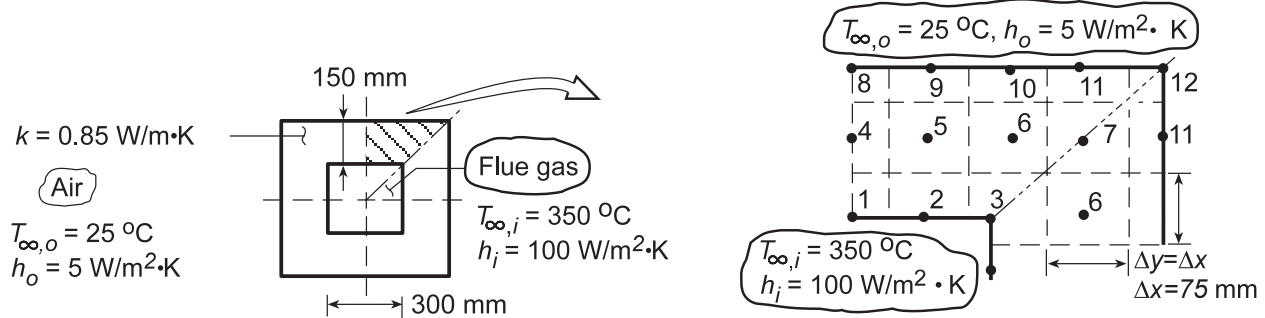

Schematic (a)

**ASSUMPTIONS:** (1) Steady-state, two-dimensional conduction, (2) Constant properties.

**ANALYSIS:** (a) Taking advantage of symmetry, the nodal network for a 75 mm grid spacing is shown in schematic (a). To obtain the heat rate, we need first to determine the temperatures  $T_i$ . Recognize that there are four types of nodes: interior (4-7), plane surface with convection (1, 2, 8-11), internal corner with convection (3), and external corner with convection (12). Using the appropriate relations from Table 4.2, the finite-difference equations are

Node		Equation
1	$(2T_4 + T_2 + T_2) + \frac{2h_i\Delta x}{k} T_{\infty,i} - 2\left(\frac{h_i\Delta x}{k} + 2\right) T_1 = 0$	4.42
2	$(2T_5 + T_3 + T_1) + \frac{2h_i\Delta x}{k} T_{\infty,i} - 2\left(\frac{h_i\Delta x}{k} + 2\right) T_2 = 0$	4.42
3	$2(T_6 + T_6) + (T_2 + T_2) + \frac{2h_i\Delta x}{k} T_{\infty,i} - 2\left(3 + \frac{h_i\Delta x}{k}\right) T_3 = 0$	4.41
4	$(T_8 + T_5 + T_1 + T_5) - 4T_4 = 0$	4.29
5	$(T_9 + T_6 + T_2 + T_4) - 4T_5 = 0$	4.29
6	$(T_{10} + T_7 + T_3 + T_5) - 4T_6 = 0$	4.29
7	$(T_{11} + T_{11} + T_6 + T_6) - 4T_7 = 0$	4.29
8	$(2T_4 + T_9 + T_9) + \frac{2h_o\Delta x}{k} T_{\infty,o} - 2\left(\frac{h_o\Delta x}{k} + 2\right) T_8 = 0$	4.42
9	$(2T_5 + T_{10} + T_8) + \frac{2h_o\Delta x}{k} T_{\infty,o} - 2\left(\frac{h_o\Delta x}{k} + 2\right) T_9 = 0$	4.42
10	$(2T_6 + T_{11} + T_9) + \frac{2h_o\Delta x}{k} T_{\infty,o} - 2\left(\frac{h_o\Delta x}{k} + 2\right) T_{10} = 0$	4.42
11	$(2T_7 + T_{12} + T_{10}) + \frac{2h_o\Delta x}{k} T_{\infty,o} - 2\left(\frac{h_o\Delta x}{k} + 2\right) T_{11} = 0$	4.42
12	$(T_{11} + T_{11}) + \frac{2h_o\Delta x}{k} T_{\infty,o} - 2\left(\frac{h_o\Delta x}{k} + 1\right) T_{12} = 0$	4.43

Continued...

### PROBLEM 4.92 (Cont.)

Substituting  $T_{\infty,o} = 350^\circ\text{C}$ ,  $h_o = 100 \text{ W/m}^2\cdot\text{K}$ ,  $T_{\infty,i} = 25^\circ\text{C}$ ,  $h_i = 5 \text{ W/m}^2\cdot\text{K}$ ,  $\Delta x = 0.075 \text{ m}$ , and  $k = 0.85 \text{ W/m}\cdot\text{K}$  and solving the preceding equations simultaneously using, for example, IHT, yields

$$T_1 = 340.4^\circ\text{C}, T_2 = 339.5^\circ\text{C}, T_3 = 329.1^\circ\text{C}, T_4 = 256.5^\circ\text{C}, T_5 = 251.4^\circ\text{C}, T_6 = 231.5^\circ\text{C}, T_7 = 182.3^\circ\text{C}, T_8 = 182.6^\circ\text{C}, T_9 = 178.3^\circ\text{C}, T_{10} = 163.1^\circ\text{C}, T_{11} = 133.1^\circ\text{C}, T_{12} = 100.0^\circ\text{C}. \quad <$$

The heat loss to the outside air for the upper surface (Nodes 8 through 12) is of the form

$$q' = h_o \Delta x \left[ \frac{1}{2}(T_8 - T_{\infty,o}) + (T_9 - T_{\infty,o}) + (T_{10} - T_{\infty,o}) + (T_{11} - T_{\infty,o}) + \frac{1}{2}(T_{12} - T_{\infty,o}) \right]$$

$$q' = 5 \text{ W/m}^2 \cdot \text{K} \times 0.075 \text{ m} \left[ \frac{1}{2}(182.6 - 25) + (178.3 - 25) + (163.1 - 25) + (133.1 - 25) + \frac{1}{2}(100.0 - 25) \right]^\circ\text{C} = 193.4 \text{ W/m}$$

Hence, for the entire flue cross-section, considering symmetry,

$$q'_{\text{tot}} = 8 \times q' = 8 \times 193.4 \text{ W/m} = 1.55 \text{ kW/m} \quad <$$

The convection heat rate at the inner surface is

$$q'_{\text{tot}} = 8 \times h_i \Delta x \left[ \frac{1}{2}(T_{\infty,i} - T_1) + (T_{\infty,i} - T_2) + \frac{1}{2}(T_{\infty,i} - T_3) \right] = 1.55 \text{ kW/m}$$

which is the same as the heat loss from the upper surface, as it must be. <

(b) Using the *Finite-Difference Equations* option from the *Tools* portion of the IHT menu, the following two-dimensional temperature field was computed for the grid shown in the schematic below, where  $x$  and  $y$  are in mm and the temperatures are in  $^\circ\text{C}$ .

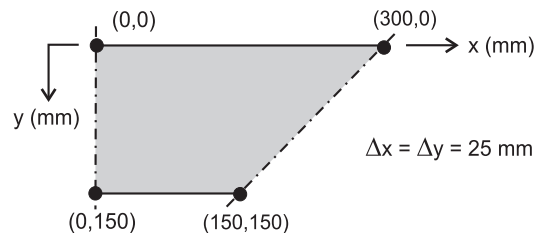

y \ x	0	25	50	75	100	125	150	175	200	225	250	275	300
0	180.7	180.2	178.4	175.4	171.1	165.3	158.1	149.6	140.1	129.9	119.4	108.7	98.0
25	204.2	203.6	201.6	198.2	193.3	186.7	178.3	168.4	157.4	145.6	133.4	121.0	
50	228.9	228.3	226.2	222.6	217.2	209.7	200.1	188.4	175.4	161.6	147.5		
75	255.0	254.4	252.4	248.7	243.1	235.0	223.9	209.8	194.1	177.8			
100	282.4	281.8	280.1	276.9	271.6	263.3	250.5	232.8	213.5				
125	310.9	310.5	309.3	307.1	303.2	296.0	282.2	257.5					
150	340.0	340.0	339.6	339.1	337.9	335.3	324.7						

Agreement between the temperature fields for the (a) and (b) grids is good, with the largest differences occurring at the interior and exterior corners. Ten isotherms generated using *FEHT* are shown on the symmetric section below. Note how the heat flow is nearly normal to the flue wall around the mid-section. In the corner regions, the isotherms are curved and we'd expect that grid size might influence the accuracy of the results. Convection heat transfer to the inner surface is

Continued...

### PROBLEM 4.92 (Cont.)

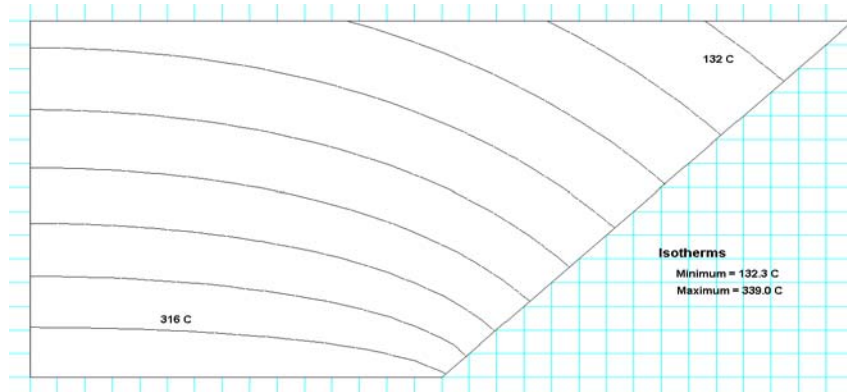

$$q' = 8h_i \Delta x \left[ \frac{(T_{\infty,i} - T_1)}{2} + (T_{\infty,i} - T_2) + (T_{\infty,i} - T_3) + (T_{\infty,i} - T_4) \right. \\ \left. + (T_{\infty,i} - T_5) + (T_{\infty,i} - T_6) + \frac{(T_{\infty,i} - T_7)}{2} \right] = 1.52 \text{ kW/m}$$

and the agreement with results of the coarse grid is excellent.

The heat rate increases with increasing  $h_i$  and  $h_o$ , while temperatures in the wall increase and decrease, respectively, with increasing  $h_i$  and  $h_o$ .

**COMMENTS.** (1) Gauss-Seidel iteration may be used to solve this system of equations. Following the procedures of Appendix D, the system of equations is rewritten in the proper form. Note that diagonal dominance is present; hence, no re-ordering is necessary.

$$\begin{aligned} T_1^k &= 0.09239T_2^{k-1} + 0.09239T_4^{k-1} + 285.3 \\ T_2^k &= 0.04620T_1^k + 0.04620T_3^{k-1} + 0.09239T_5^{k-1} + 285.3 \\ T_3^k &= 0.08457T_2^k + 0.1692T_6^{k-1} + 261.2 \\ T_4^k &= 0.25T_1^k + 0.50T_5^{k-1} + 0.25T_8^{k-1} \\ T_5^k &= 0.25T_2^k + 0.25T_4^k + 0.25T_6^{k-1} + 0.25T_9^{k-1} \\ T_6^k &= 0.25T_3^k + 0.25T_5^k + 0.25T_7^{k-1} + 0.25T_9^{k-1} \\ T_7^k &= 0.50T_6^k + 0.50T_{11}^{k-1} \\ T_8^k &= 0.4096T_4^k + 0.4096T_9^{k-1} + 4.52 \\ T_9^k &= 0.4096T_5^k + 0.2048T_8^k + 0.2048T_{10}^{k-1} + 4.52 \\ T_{10}^k &= 0.4096T_6^k + 0.2048T_9^k + 0.2048T_{11}^{k-1} + 4.52 \\ T_{11}^k &= 0.4096T_7^k + 0.2048T_{10}^k + 0.2048T_{12}^{k-1} + 4.52 \\ T_{12}^k &= 0.6939T_{11}^k + 7.65 \end{aligned}$$

Continued...

### PROBLEM 4.92 (Cont.)

The initial estimates ( $k = 0$ ) are carefully chosen to minimize calculation labor; let  $\varepsilon < 1.0$ .

k	T <sub>1</sub>	T <sub>2</sub>	T <sub>3</sub>	T <sub>4</sub>	T <sub>5</sub>	T <sub>6</sub>	T <sub>7</sub>	T <sub>8</sub>	T <sub>9</sub>	T <sub>10</sub>	T <sub>11</sub>	T <sub>12</sub>
0	340	330	315	250	225	205	195	160	150	140	125	110
1	338.9	336.3	324.3	237.2	232.1	225.4	175.2	163.1	161.7	155.6	130.7	98.3
2	338.3	337.4	328.0	241.4	241.5	226.6	178.6	169.6	170.0	158.9	130.4	98.1
3	338.8	338.4	328.2	247.7	245.7	230.6	180.5	175.6	173.7	161.2	131.6	98.9
4	339.4	338.8	328.9	251.6	248.7	232.9	182.3	178.7	176.0	162.9	132.8	99.8
5	339.8	339.2	329.3	254.0	250.5	234.5	183.7	180.6	177.5	164.1	133.8	100.5
6	340.1	339.4	329.7	255.4	251.7	235.7	184.7	181.8	178.5	164.7	134.5	101.0
7	340.3	339.5	329.9	256.4	252.5	236.4	185.5	182.7	179.1	165.6	135.1	101.4

The heat loss to the outside air for the upper surface (Nodes 8 through 12) is of the form

$$q' = h_o \Delta x \left[ \frac{1}{2}(T_8 - T_{\infty,o}) + (T_9 - T_{\infty,o}) + (T_{10} - T_{\infty,o}) + (T_{11} - T_{\infty,o}) + \frac{1}{2}(T_{12} - T_{\infty,o}) \right]$$

$$q' = 5 \text{ W/m}^2 \cdot \text{K} \times 0.075 \text{ m} \left[ \frac{1}{2}(182.7 - 25) + (179.1 - 25) + (165.6 - 25) + (135.1 - 25) + \frac{1}{2}(101.4 - 25) \right] \text{ }^\circ\text{C} = 195 \text{ W/m}$$

Hence, for the entire flue cross-section, considering symmetry,

$$q'_{\text{tot}} = 8 \times q' = 8 \times 195 \text{ W/m} = 1.57 \text{ kW/m} \quad <$$

The convection heat rate at the inner surface is

$$q'_{\text{tot}} = 8 \times h_i \Delta x \left[ \frac{1}{2}(T_{\infty,i} - T_1) + (T_{\infty,i} - T_2) + \frac{1}{2}(T_{\infty,i} - T_3) \right] = 8 \times 190.5 \text{ W/m} = 1.52 \text{ kW/m}$$

which is within 2.5% of the foregoing result. The convection heat rates would be identical when  $\varepsilon = 0$ .

(2) For this problem the Gauss-Seidel iteration method is cumbersome, time-consuming and inaccurate unless many more iterations are included. For relatively small systems of simultaneous equations such as in this problem, enhanced accuracy can usually be obtained with far less effort through use of a numerical solver such as available on many handheld calculators, IHT or some other commercial code.

### PROBLEM 4.93

**KNOWN:** Electronic device cooled by conduction to a heat sink.

**FIND:** (a) Beginning with a symmetrical element, find the thermal resistance per unit depth between the device and lower surface of the sink,  $R'_{t,d-s}$  (m-K/W) using a coarse (5x5) nodal network, determine  $R'_{t,d-s}$ ; (b) Using nodal networks with finer grid spacings, determine the effect of grid size on the precision of the thermal resistance calculation; (c) Using a fine nodal network, determine the effect of device width on  $R'_{t,d-s}$  with  $w_d/w_s = 0.175, 0.275, 0.375$  and  $0.475$  keeping  $w_s$  and  $L$  fixed.

**SCHEMATIC:**

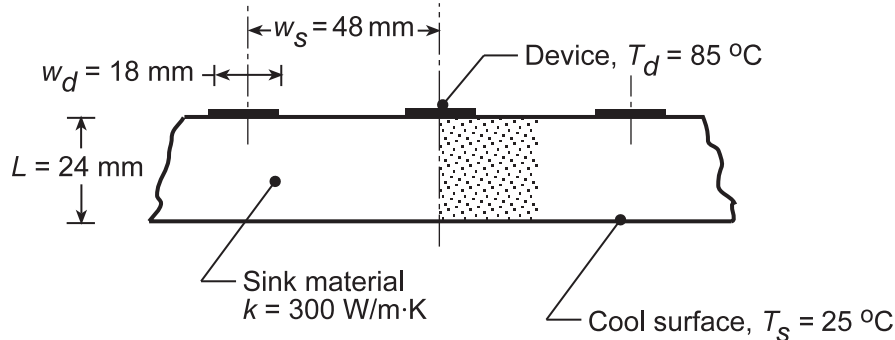

**ASSUMPTIONS:** (1) Steady-state, two-dimensional conduction, (2) Constant properties, and (3) No internal generation, (4) Top surface not covered by device is insulated.

**ANALYSIS:** (a) The coarse 5x5 nodal network is shown in the sketch including the nodes adjacent to the symmetry lines and the adiabatic surface. As such, all the finite-difference equations are interior nodes and can be written by inspection directly onto the IHT workspace. Alternatively, one could use the *IHT Finite-Difference Equations Tool*. The temperature distribution (°C) is tabulated in the same arrangement as the nodal network.

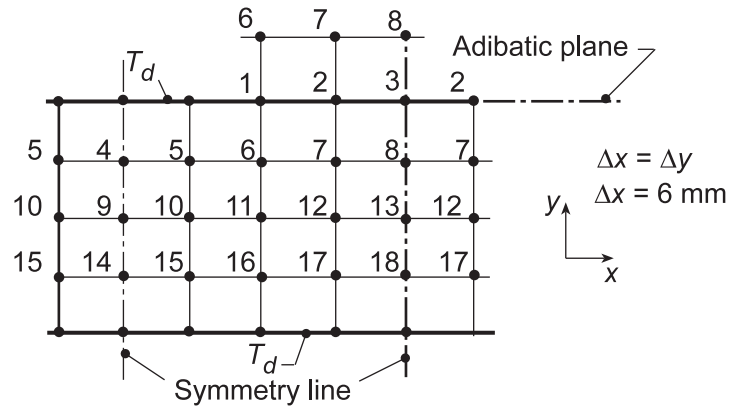

85.00	85.00	62.31	53.26	50.73
65.76	63.85	55.49	50.00	48.20
50.32	49.17	45.80	43.06	42.07
37.18	36.70	35.47	34.37	33.95
25.00	25.00	25.00	25.00	25.00

The thermal resistance between the device and sink per unit depth is

$$R'_{t,s-d} = \frac{T_d - T_s}{2q'_{tot}}$$

Continued...

### PROBLEM 4.93 (Cont.)

Performing an energy balance on the device nodes, find

$$q'_{tot} = q'_a + q'_b + q'_c$$

$$q'_{tot} = k(\Delta y/2) \frac{T_d - T_1}{\Delta x} + k\Delta x \frac{T_d - T_5}{\Delta y} + k(\Delta x/2) \frac{T_d - T_4}{\Delta y}$$

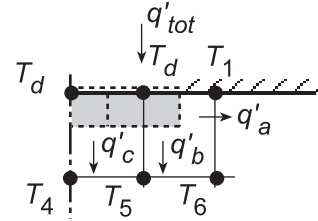

$$q'_{tot} = 300 \text{ W/m} \cdot \text{K} \left[ \frac{(85 - 62.31)}{2} + (85 - 63.85) + \frac{(85 - 65.76)}{2} \right] \text{ K} = 1.263 \times 10^4 \text{ W/m}$$

$$R'_{t,s-d} = \frac{(85 - 25) \text{ K}}{2 \times 1.263 \times 10^4 \text{ W/m}} = 2.38 \times 10^{-3} \text{ m} \cdot \text{K/W}$$

(b) The effect of grid size on the precision of the thermal resistance estimate should be tested by systematically reducing the nodal spacing  $\Delta x$  and  $\Delta y$ . This is a considerable amount of work even with IHT since the equations need to be individually entered. A more generalized, powerful code would be required which allows for automatically selecting the grid size. Using FEHT, a finite-element package, with eight elements across the device, representing a much finer mesh, we found

$$R'_{t,s-d} = 3.64 \times 10^{-3} \text{ m} \cdot \text{K/W}$$

(c) Using the same tool, with the finest mesh, the thermal resistance was found as a function of  $w_d/w_s$  with fixed  $w_s$  and  $L$ .

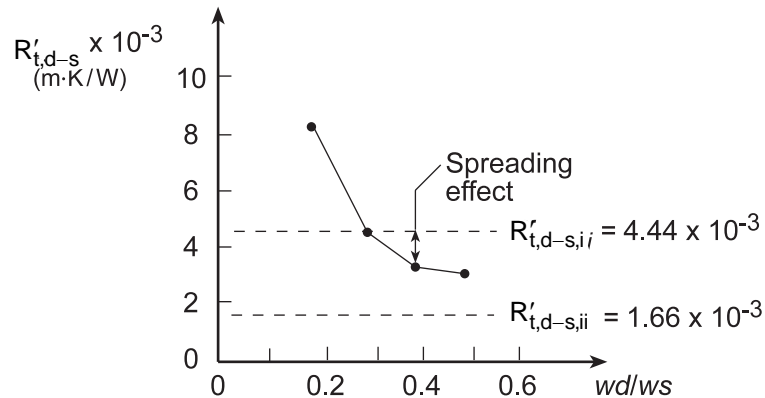

As expected, as  $w_d$  increases,  $R'_{t,d-s}$  decreases, and eventually will approach the value for the rectangular domain (ii). The spreading effect is shown for the base case,  $w_d/w_s = 0.375$ , where the thermal resistance of the sink is less than that for the rectangular domain (i).

**COMMENTS:** It is useful to compare the results for estimating the thermal resistance in terms of precision requirements and level of effort,

	$R'_{t,d-s} \times 10^3 \text{ (m} \cdot \text{K/W)}$
Rectangular domain (i)	4.44
Flux plot	3.03
Rectangular domain (ii)	1.67
FDE, 5x5 network	2.38
FEA, fine mesh	3.64

### PROBLEM 4.94

**KNOWN:** Plane composite wall with exposed surfaces maintained at fixed temperatures. Material A has temperature-dependent thermal conductivity.

**FIND:** Heat flux through the wall (a) assuming a uniform thermal conductivity in material A evaluated at the average temperature of the section, and considering the temperature-dependent thermal conductivity of material A using (b) a finite-difference method of solution in IHT with a space increment of 1 mm and (c) the finite-element method of FEHT.

**SCHEMATIC:**

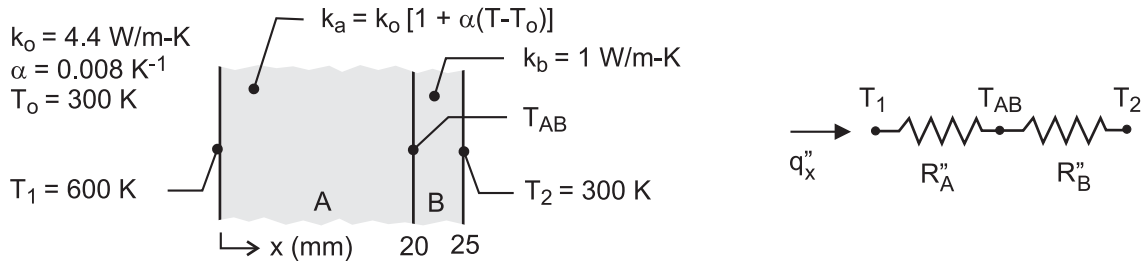

**ASSUMPTIONS:** (1) Steady-state, one-dimensional conduction, (2) No thermal contact resistance between the materials, and (3) No internal generation.

**ANALYSIS:** (a) From the thermal circuit in the above schematic, the heat flux is

$$q_x'' = \frac{T_1 - T_2}{R_A'' + R_B''} = \frac{T_{AB} - T_2}{R_B''} \quad (1, 2)$$

and the thermal resistances of the two sections are

$$R_A'' = L_A / k_A \quad R_B'' = L_B / k_B \quad (3, 4)$$

The thermal conductivity of material A is evaluated at the average temperature of the section

$$k_A = k_o \left\{ 1 + \alpha \left[ \frac{(T_1 + T_{AB})}{2} - T_o \right] \right\} \quad (5)$$

Substituting numerical values and solving the system of equations simultaneously in IHT, find

$$T_{AB} = 563.2 \text{ K} \quad q_x'' = 52.64 \text{ kW/m}^2 \quad <$$

(b) The nodal arrangement for the finite-difference method of solution is shown in the schematic below. FDEs must be written for the internal nodes (02 – 10, 12 – 15) and the A-B interface node (11) considering in section A, the temperature-dependent thermal conductivity.

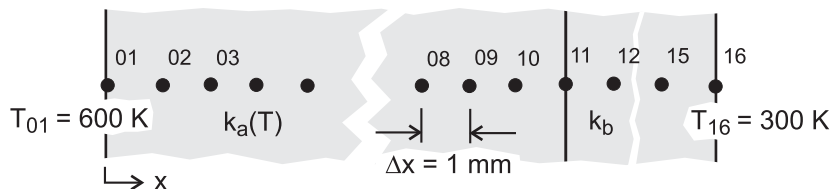

*Interior Nodes, Section A (m = 02, 03 ... 10)*

Referring to the schematic below, the energy balance on node  $m$  is written in terms of the heat fluxes at the control surfaces using Fourier's law with the thermal conductivity based upon the average temperature of adjacent nodes. The heat fluxes into node  $m$  are

Continued ...

**PROBLEM 4.94 (Cont.)**

$$q_c'' = k_a (m, m+1) \frac{T_{m+1} - T_m}{\Delta x} \quad (1)$$

$$q_d'' = k_a (m-1, m) \frac{T_{m-1} - T_m}{\Delta x} \quad (2)$$

and the FDEs are obtained from the energy balance written as

$$q_c'' + q_d'' = 0 \quad (3)$$

$$k_a (m, m+1) \frac{T_{m+1} - T_m}{\Delta x} + k_a (m-1, m) \frac{T_{m-1} - T_m}{\Delta x} = 0 \quad (4)$$

where the thermal conductivities averaged over the path between the nodes are expressed as

$$k_a (m-1, m) = k_o \left\{ 1 + \alpha \left[ (T_{m-1} + T_m) / 2 - T_o \right] \right\} \quad (5)$$

$$k_a (m, m+1) = k_o \left\{ 1 + \alpha \left[ (T_m + T_{m+1}) / 2 - T_o \right] \right\} \quad (6)$$

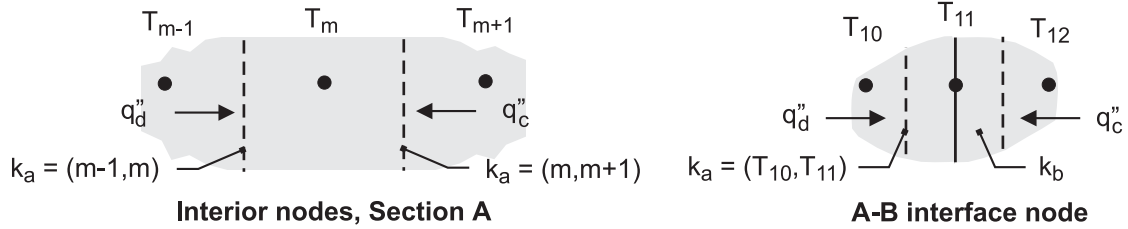

*A-B Interface Node 11*

Referring to the above schematic, the energy balance on the interface node,  $q_c'' + q_d'' = 0$ , has the form

$$k_b \frac{T_{12} - T_{11}}{\Delta x} + k_a (10, 11) \frac{T_{10} - T_{11}}{\Delta x} = 0 \quad (7)$$

where the thermal conductivity in the section A path is

$$k(10, 11) = k_o \left\{ 1 + \left[ (T_{10} + T_{11}) / 2 - T_o \right] \right\} \quad (8)$$

*Interior Nodes, Section B (n = 12 ... 15)*

Since the thermal conductivity in Section B is uniform, the FDEs have the form

$$T_n = (T_{n-1} + T_{n+1}) / 2 \quad (9)$$

And the heat flux in the x-direction is

$$q_x'' = k_b \frac{T_n - T_{n+1}}{\Delta x} \quad (10)$$

*Finite-Difference Method of Solution*

The foregoing FDE equations for section A nodes ( $m = 02$  to  $10$ ), the AB interface node and their respective expressions for the thermal conductivity,  $k(m, m+1)$ , and for section B nodes are entered into the IHT workspace and solved for the temperature distribution. The heat flux can be evaluated using Eq. (2) or (10). A portion of the IHT code is contained in the Comments, and the results of the analysis are tabulated below.

$$T_{11} = T_{AB} = 563.2 \text{ K} \quad q_x'' = 52.64 \text{ kW/m}^2 \quad <$$

Continued ...



### PROBLEM 4.94 (Cont.)

(c) The finite-element method of FEHT can be used readily to obtain the heat flux considering the temperature-dependent thermal conductivity of section A. Draw the composite wall outline with properly scaled section thicknesses in the x-direction with an arbitrary y-direction dimension. In the *Specify | Materials Properties* box for the thermal conductivity, specify  $k_a$  as  $4.4*[1 + 0.008*(T - 300)]$  having earlier selected *Set | Temperatures in K*. The results of the analysis are

$$T_{AB} = 563 \text{ K} \qquad q_x'' = 52.6 \text{ kW/m}^2 \qquad <$$

**COMMENTS:** (1) The results from the three methods of analysis compare very well. Because the thermal conductivity in section A is linear, and moderately dependent on temperature, the simplest method of using an overall section average, part (a), is recommended. This same method is recommended when using tabular data for temperature-dependent properties.

(2) For the finite-difference method of solution, part (b), the heat flux was evaluated at several nodes within section A and in section B with identical results. This is a consequence of the technique for averaging  $k_a$  over the path between nodes in computing the heat flux into a node.

(3) To illustrate the use of IHT in solving the finite-difference method of solution, lines of code for representative nodes are shown below.

```
// FDEs – Section A
k01_02 * (T01-T02)/deltax + k02_03 * (T03-T02)/deltax = 0
k01_02 = ko * (1+ alpha * ((T01 + T02)/2 - To))
k02_03 = ko * (1 + alpha * ((T02 + T03)/2 - To))

k02_03 * (T02 - T03)/deltax + k03_04 * (T04 - T03)/deltax = 0
k03_04 = ko * (1 + alpha * ((T03 + T04)/2 - To))

// Interface, node 11
k11 * (T10 - T11)/deltax + kb * (T12 - T11)/deltax = 0
k11 = ko * (1 + alpha * ((T10 + T11)/2 - To))

// Section B (using Tools/FDE/One-dimensional/Steady-state)
/* Node 12: interior node; */
0.0 = fd_1d_int(T12, T13, T11, kb, qdot, deltax)
```

## PROBLEM 4.95

**KNOWN:** Upper surface of a platen heated by hot fluid through the flow channels is used to heat a process fluid.

**FIND:** (a) The maximum allowable spacing,  $W$ , between channel centerlines that will provide a uniform temperature requirement of  $5^\circ\text{C}$  on the upper surface of the platen, and (b) Heat rate per unit length from the flow channel for this condition.

**SCHEMATIC:**

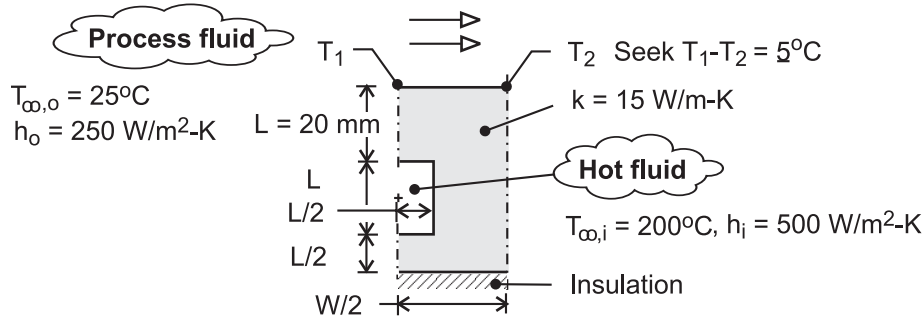

**ASSUMPTIONS:** (1) Steady-state, two-dimensional conduction with constant properties, and (2) Lower surface of platen is adiabatic.

**ANALYSIS:** As shown in the schematic above for a symmetrical section of the platen-flow channel arrangement, the temperature uniformity requirement will be met when  $T_1 - T_2 = 5^\circ\text{C}$ . The maximum temperature,  $T_1$ , will occur directly over the flow channel centerline, while the minimum surface temperature,  $T_2$ , will occur at the mid-span between channel centerlines.

We chose to use FEHT to obtain the temperature distribution and heat rate for guessed values of the channel centerline spacing,  $W$ . The following method of solution was used: (1) Make an initial guess value for  $W$ ; try  $W = 100$  mm, (2) Draw an outline of the symmetrical section, and assign properties and boundary conditions, (3) Make a copy of this file so that in your second trial, you can use the *Draw | Move Node* option to modify the section width,  $W/2$ , larger or smaller, (4) Draw element lines within the outline to create triangular elements, (5) Use the *Draw | Reduce Mesh* command to generate a suitably fine mesh, then solve for the temperature distribution, (6) Use the *View | Temperatures* command to determine the temperatures  $T_1$  and  $T_2$ , (7) If,  $T_1 - T_2 \approx 5^\circ\text{C}$ , use the *View | Heat Flows* command to find the heat rate, otherwise, change the width of the section outline and repeat the analysis. The results of our three trials are tabulated below.

Trial	$W$ (mm)	$T_1$ ( $^\circ\text{C}$ )	$T_2$ ( $^\circ\text{C}$ )	$T_1 - T_2$ ( $^\circ\text{C}$ )	$q'$ (W/m)
1	100	108	98	10	--
2	60	119	118	1	--
3	80	113	108	5	1706

**COMMENTS:** (1) In addition to the tutorial example in the FEHT User's Manual, the solved models for Examples 4.3 and 4.4 of the Text are useful for developing skills in using this problem-solving tool.

(2) An alternative numerical method of solution would be to create a nodal network, generate the finite-difference equations and solve for the temperature distribution and the heat rate. The FDEs should allow for a non-square grid,  $\Delta x \neq \Delta y$ , so that different values for  $W/2$  can be accommodated by changing the value of  $\Delta x$ . Even using the IHT tool for building FDEs (*Tools | Finite-Difference Equations | Steady-State*) this method of solution is very labor intensive because of the large number of nodes required for obtaining good estimates.

## PROBLEM 4.96

**KNOWN:** Silicon chip mounted in a dielectric substrate. One surface of system is convectively cooled, while the remaining surfaces are well insulated. See Problem 4.93. Use the finite-element software *FEHT* as your analysis tool.

**FIND:** (a) The temperature distribution in the substrate-chip system; does the maximum temperature exceed  $85^\circ\text{C}$ ?; (b) Volumetric heating rate that will result in a maximum temperature of  $85^\circ\text{C}$ ; and (c) Effect of reducing thickness of substrate from 12 to 6 mm, keeping all other dimensions unchanged with  $\dot{q} = 1 \times 10^7 \text{ W/m}^3$ ; maximum temperature in the system for these conditions, and fraction of the power generated within the chip removed by convection directly from the chip surface.

**SCHEMATIC:**

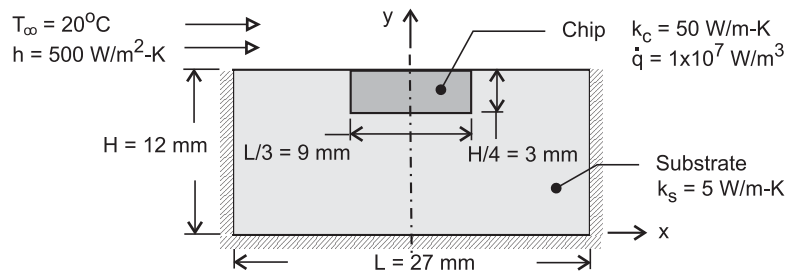

**ASSUMPTIONS:** (1) Steady-state conditions, (2) Two-dimensional conduction in system, and (3) Uniform convection coefficient over upper surface.

**ANALYSIS:** Using *FEHT*, the symmetrical section is represented in the workspace as two connected regions, chip and substrate. *Draw* first the chip outline; *Specify* the material and generation parameters. Now, *Draw* the outline of the substrate, connecting the nodes of the interfacing surfaces; *Specify* the material parameters for this region. Finally, *Assign the Boundary Conditions*: zero heat flux for the symmetry and insulated surfaces, and convection for the upper surface. *Draw Element Lines*, making the triangular elements near the chip and surface smaller than near the lower insulated boundary as shown in a copy of the *FEHT* screen on the next page. Use the *Draw/Reduce Mesh* command and *Run* the model.

(a) Use the *View/Temperature* command to see the nodal temperatures through out the system. As expected, the hottest location is on the centerline of the chip at the bottom surface. At this location, the temperature is

$$T(0, 9 \text{ mm}) = 46.7^\circ\text{C} \quad <$$

(b) Run the model again, with different values of the generation rate until the temperature at this location is  $T(0, 9 \text{ mm}) = 85^\circ\text{C}$ , finding

$$\dot{q} = 2.43 \times 10^7 \text{ W/m}^3 \quad <$$

Continued ...

### PROBLEM 4.96 (Cont.)

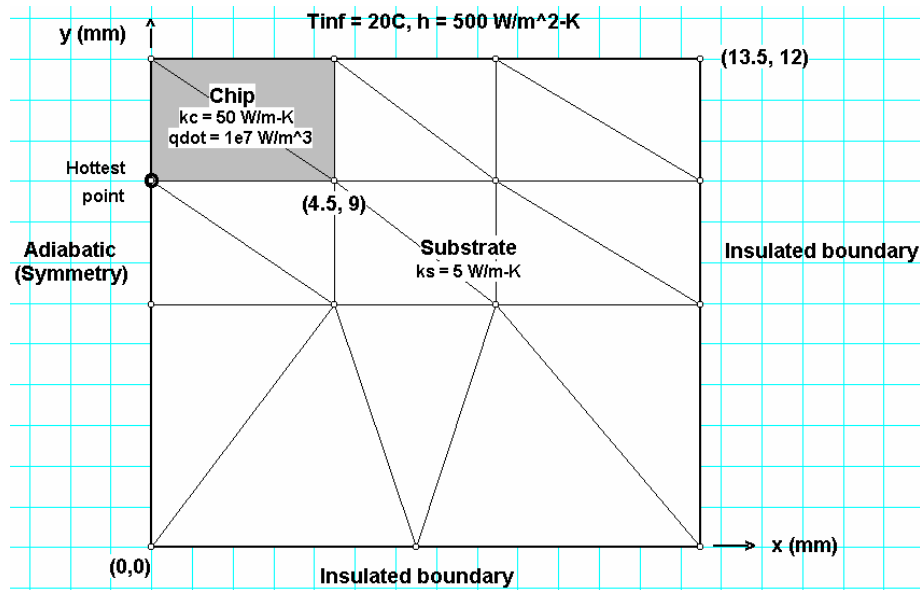

(c) Returning to the model code with the conditions of part (a), reposition the nodes on the lower boundary, as well as the intermediate ones, to represent a substrate that is of 6-mm, rather than 12-mm thickness. Find the maximum temperature as

$$T(0, 3 \text{ mm}) = 47.5^\circ\text{C}$$

<

Using the *View/Heat Flow* command, click on the adjacent line segments forming the chip surface exposed to the convection process. The heat rate per unit width (normal to the page) is

$$q'_{\text{chip,cv}} = 60.26 \text{ W/m}$$

The total heat generated within the chip is

$$q'_{\text{tot}} = \dot{q}(L/6 \times H/4) = 1 \times 10^7 \text{ W/m}^3 \times (0.0045 \times 0.003) \text{ m}^2 = 135 \text{ W/m}$$

so that the fraction of the power dissipated by the chip that is convected directly to the coolant stream is

$$F = q'_{\text{chip,cv}} / q'_{\text{tot}} = 60.26 / 135 = 45\%$$

<

**COMMENTS:** (1) Comparing the maximum temperatures for the system with the 12-mm and 6-mm thickness substrates, note that the effect of halving the substrate thickness is to raise the maximum temperature by less than 1°C. The thicker substrate does not provide significantly improved heat removal capability.

(2) Without running the code for part (b), estimate the magnitude of  $\dot{q}$  that would make  $T(0, 9 \text{ mm}) = 85^\circ\text{C}$ . Did you get  $\dot{q} = 2.43 \times 10^7 \text{ W/m}^3$ ? Why?

### PROBLEM 5.1

**KNOWN:** Electrical heater attached to backside of plate while front surface is exposed to convection process ( $T_{\infty,h}$ ); initially plate is at a uniform temperature of the ambient air and suddenly heater power is switched on providing a constant  $q_0''$ .

**FIND:** (a) Sketch temperature distribution,  $T(x,t)$ , (b) Sketch the heat flux at the outer surface,  $q_x''(L,t)$  as a function of time.

**SCHEMATIC:**

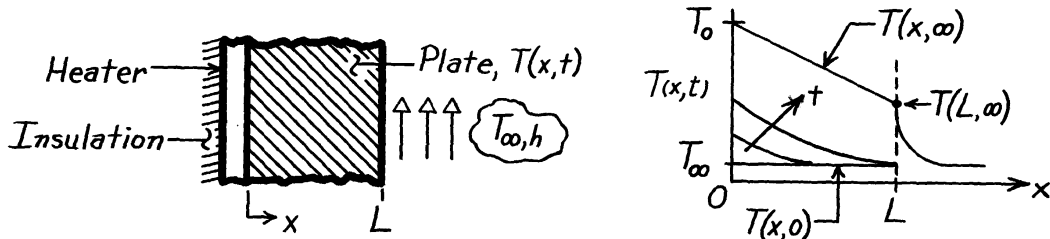

**ASSUMPTIONS:** (1) One-dimensional conduction, (2) Constant properties, (3) Negligible heat loss from heater through insulation.

**ANALYSIS:** (a) The temperature distributions for four time conditions including the initial distribution,  $T(x,0)$ , and the steady-state distribution,  $T(x,\infty)$ , are as shown above.

Note that the temperature gradient at  $x = 0$ ,  $-dT/dx|_{x=0}$ , for  $t > 0$  will be a constant since the flux,  $q_x''(0)$ , is a constant. Noting that  $T_0 = T(0,\infty)$ , the steady-state temperature distribution will be linear such that

$$q_0'' = k \frac{T_0 - T(L,\infty)}{L} = h [T(L,\infty) - T_{\infty}].$$

(b) The heat flux at the front surface,  $x = L$ , is given by  $q_x''(L,t) = -k(dT/dx)|_{x=L}$ . From the temperature distribution, we can construct the heat flux-time plot.

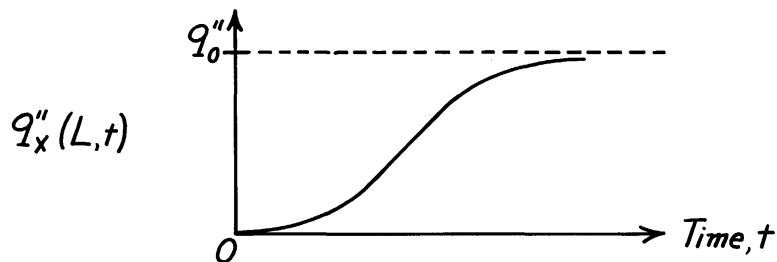

**COMMENTS:** At early times, the temperature and heat flux at  $x = L$  will not change from their initial values. Hence, we show a zero slope for  $q_x''(L,t)$  at early times. Eventually, the value of  $q_x''(L,t)$  will reach the steady-state value which is  $q_0''$ .

## PROBLEM 5.2

**KNOWN:** Plane wall whose inner surface is insulated and outer surface is exposed to an airstream at  $T_\infty$ . Initially, the wall is at a uniform temperature equal to that of the airstream. Suddenly, a radiant source is switched on applying a uniform flux,  $q_o''$ , to the outer surface.

**FIND:** (a) Sketch temperature distribution on T-x coordinates for initial, steady-state, and two intermediate times, (b) Sketch heat flux at the outer surface,  $q_x''(L,t)$ , as a function of time.

**SCHEMATIC:**

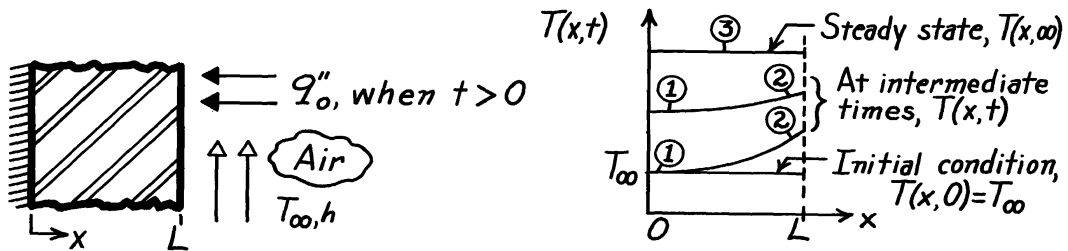

**ASSUMPTIONS:** (1) One-dimensional conduction, (2) Constant properties, (3) No internal generation,  $\dot{E}_g = 0$ , (4) Surface at  $x = 0$  is perfectly insulated, (5) All incident radiant power is absorbed and negligible radiation exchange with surroundings.

**ANALYSIS:** (a) The temperature distributions are shown on the T-x coordinates and labeled accordingly. Note these special features: (1) Gradient at  $x = 0$  is always zero, (2) gradient is more steep at early times and (3) for steady-state conditions, the radiant flux is equal to the convective heat flux (this follows from an energy balance on the CS at  $x = L$ ),

$$q_o'' = q_{\text{conv}}'' = h [T(L,\infty) - T_\infty].$$

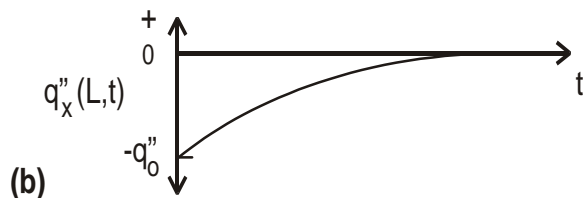
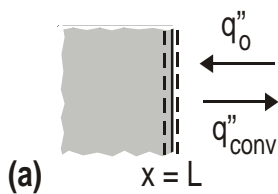

(b) The heat flux at the outer surface,  $q_x''(L,t)$ , as a function of time appears as shown above.

**COMMENTS:** The sketches must reflect the initial and boundary conditions:

$T(x,0) = T_\infty$	uniform initial temperature.
$-k \frac{\partial T}{\partial x} \Big _{x=0} = 0$	insulated at $x = 0$ .
$-k \frac{\partial T}{\partial x} \Big _{x=L} = h [T(L,t) - T_\infty] - q_o''$	surface energy balance at $x = L$ .

### PROBLEM 5.3

**KNOWN:** Microwave and radiant heating conditions for a slab of beef.

**FIND:** Sketch temperature distributions at specific times during heating and cooling.

**SCHEMATIC:**

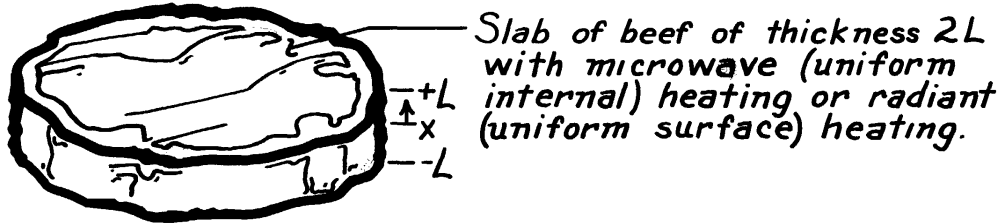

**ASSUMPTIONS:** (1) One-dimensional conduction in  $x$ , (2) Uniform internal heat generation for microwave, (3) Uniform surface heating for radiant oven, (4) Heat loss from surface of meat to surroundings is negligible during the heating process, (5) Symmetry about midplane.

**ANALYSIS:**

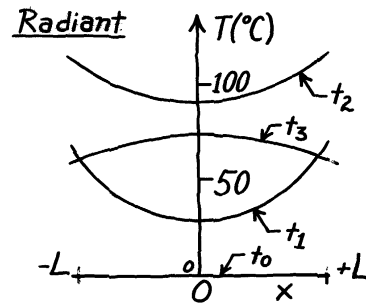
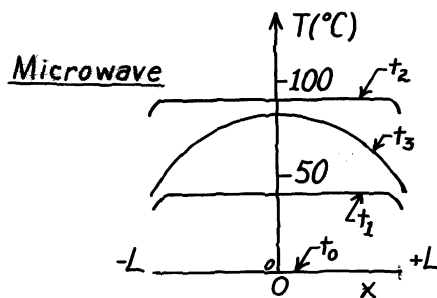

**COMMENTS:** (1) With uniform generation and negligible surface heat loss, the temperature distribution remains nearly uniform during *microwave heating*. During the subsequent surface cooling, the maximum temperature is at the midplane.

(2) The interior of the meat is heated by conduction from the hotter surfaces during *radiant heating*, and the lowest temperature is at the midplane. The situation is reversed shortly after cooling begins, and the maximum temperature is at the midplane.

### PROBLEM 5.4

**KNOWN:** Plate initially at a uniform temperature  $T_i$  is suddenly subjected to convection process ( $T_\infty, h$ ) on both surfaces. After elapsed time  $t_0$ , plate is insulated on both surfaces.

**FIND:** (a) Assuming  $Bi \gg 1$ , sketch on  $T - x$  coordinates: initial and steady-state ( $t \rightarrow \infty$ ) temperature distributions,  $T(x, t_0)$  and distributions for two intermediate times  $t_0 < t < \infty$ , (b) Sketch on  $T - t$  coordinates midplane and surface temperature histories, (c) Repeat parts (a) and (b) assuming  $Bi \ll 1$ , and (d) Obtain expression for  $T(x, \infty) = T_f$  in terms of plate parameters ( $M, c_p$ ), thermal conditions ( $T_i, T_\infty, h$ ), surface temperature  $T(L, t)$  and heating time  $t_0$ .

**SCHEMATIC:**

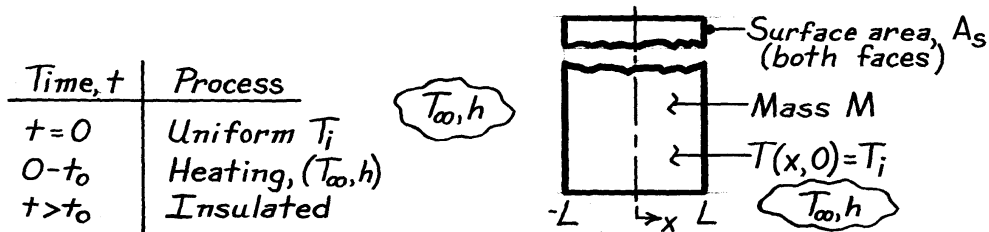

**ASSUMPTIONS:** (1) One-dimensional conduction, (2) Constant properties, (3) No internal generation, (4) Plate is perfectly insulated for  $t > t_0$ , (5)  $T(0, t < t_0) < T_\infty$ .

**ANALYSIS:** (a,b) With  $Bi \gg 1$ , appreciable temperature gradients exist in the plate following exposure to the heating process.

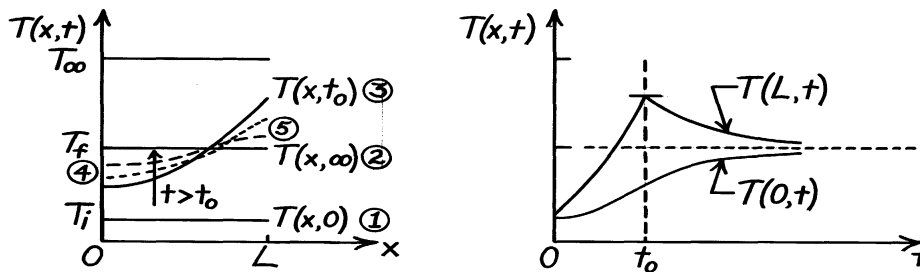

On  $T-x$  coordinates: (1) initial, uniform temperature, (2) steady-state conditions when  $t \rightarrow \infty$ , (3) distribution at  $t_0$  just before plate is covered with insulation, (4) gradients are always zero (symmetry), and (5) when  $t > t_0$  (dashed lines) gradients approach zero everywhere.

(c) If  $Bi \ll 1$ , plate is space-wise isothermal (no gradients). On  $T-x$  coordinates, the temperature distributions are flat; on  $T-t$  coordinates,  $T(L, t) = T(0, t)$ .

(d) The conservation of energy requirement for the interval of time  $\Delta t = t_0$  is

$$E_{in} - E_{out} = \Delta E = E_{final} - E_{initial} \quad 2 \int_0^{t_0} h A_s [T_\infty - T(L, t)] dt - 0 = M c_p (T_f - T_i)$$

where  $E_{in}$  is due to convection heating over the period of time  $t = 0 \rightarrow t_0$ . With knowledge of  $T(L, t)$ , this expression can be integrated and a value for  $T_f$  determined.



## PROBLEM 5.5

**KNOWN:** Geometries of various objects. Material and/or properties. Cases (a) through (d): Convection heat transfer coefficient between object and surrounding fluid. Case (e): Emissivity of sphere, initial temperature, and temperature of surroundings. Cases (f) and (g): Initial temperature, spatially averaged temperature at a later time, and surrounding fluid temperature.

**FIND:** Characteristic length and Biot number. Validity of lumped capacitance approximation.

**SCHEMATIC:**

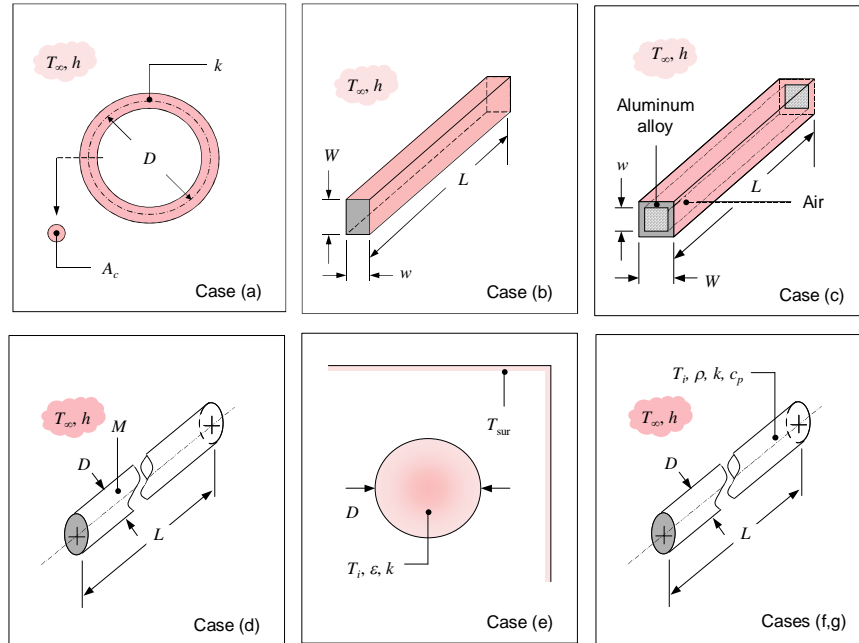

Case (a):  $D = 50 \text{ mm}$ ,  $A_c = 5 \text{ mm}^2$ ,  $k = 2.3 \text{ W/m}\cdot\text{K}$ ,  $h = 50 \text{ W/m}^2\cdot\text{K}$ .

Case (b):  $W = 5 \text{ mm}$ ,  $w = 3 \text{ mm}$ ,  $L = 100 \text{ mm}$ ,  $h = 15 \text{ W/m}^2\cdot\text{K}$ , AISI 304 stainless steel.

Case (c):  $w = 20 \text{ mm}$ ,  $W = 24 \text{ mm}$ ,  $h = 37 \text{ W/m}^2\cdot\text{K}$  ( $L$  not specified), 2024 aluminum.

Case (d):  $L = 300 \text{ mm}$ ,  $D = 13 \text{ mm}$ ,  $M = 0.328 \text{ kg}$ ,  $h = 30 \text{ W/m}^2\cdot\text{K}$ . stainless steel.

Case (e):  $D = 12 \text{ mm}$ ,  $k = 120 \text{ W/m}\cdot\text{K}$ ,  $T_{\text{sur}} = 20^\circ\text{C}$ ,  $T_i = 100^\circ\text{C}$ ,  $\varepsilon = 0.73$ .

Cases (f,g):  $D = 20 \text{ mm}$  or  $200 \text{ mm}$ ,  $\rho = 2300 \text{ kg/m}^3$ ,  $c_p = 1750 \text{ J/kg}\cdot\text{K}$ ,  $k = 16 \text{ W/m}\cdot\text{K}$ ,  $T_\infty = 20^\circ\text{C}$ ,  $T_i = 200^\circ\text{C}$ ,  $T = 100^\circ\text{C}$  at  $t = 225 \text{ s}$ .

**ASSUMPTIONS:** (1) Constant properties, (2) In case (e), radiation is to large surroundings.

**PROPERTIES:** Table A.1, Stainless steel, AISI 304 ( $T = 300 \text{ K}$ ):  $k = 14.9 \text{ W/m}\cdot\text{K}$ . Aluminum 2024 ( $T = 300 \text{ K}$ ):  $k = 177 \text{ W/m}\cdot\text{K}$ .

**ANALYSIS:** Characteristic lengths can be calculated as  $L_{c1} = V/A_s$ , or they can be taken conservatively as the dimension corresponding to the maximum spatial temperature difference,  $L_{c2}$ . The former definition is more convenient for complex geometries. The lumped capacitance approximation is valid for  $Bi = hL_c/k < 0.1$ .

(a) The radius of the torus,  $r_o$ , can be found from  $A_c = \pi r_o^2$ . The characteristic lengths are

$$L_{c1} = \frac{V}{A_s} = \frac{A_c \pi D}{2\pi \sqrt{A_c} / \pi \times \pi D} = \frac{1}{2} \sqrt{\frac{A_c}{\pi}} = \frac{1}{2} \sqrt{\frac{5 \text{ mm}^2}{\pi}} = 0.63 \text{ mm}$$

<

Continued...

### PROBLEM 5.5 (Cont.)

$$L_{c2} = \text{Maximum center to surface distance} = \text{radius} = \sqrt{A_c / \pi} = \sqrt{5 \text{ mm}^2 / \pi} = 1.26 \text{ mm}$$

The corresponding Biot numbers are

$$Bi_1 = \frac{hL_{c1}}{k} = \frac{50 \text{ W/m}^2 \cdot \text{K} \times 0.00063 \text{ m}}{2.3 \text{ W/m} \cdot \text{K}} = 0.014$$

$$Bi_2 = \frac{hL_{c2}}{k} = \frac{50 \text{ W/m}^2 \cdot \text{K} \times 0.00126 \text{ m}}{2.3 \text{ W/m} \cdot \text{K}} = 0.027$$

The lumped capacitance approximation is valid according to either definition.

(b) For this complex shape, we will calculate only  $L_{c1}$ .

$$L_{c1} = \frac{V}{A_s} = \frac{WwL}{2(W+w)L + 2Ww} = \frac{5 \text{ mm} \times 3 \text{ mm} \times 100 \text{ mm}}{2(5 \text{ mm} + 3 \text{ mm}) \times 100 \text{ mm} + 25 \text{ mm} \times 3 \text{ mm}} = 0.90 \text{ mm}$$

Notice that the surface area of the ends has been included, and does have a small effect on the result – 0.90 mm versus 0.94 mm if the ends are neglected. The corresponding Biot number is

$$Bi_1 = \frac{hL_{c1}}{k} = \frac{15 \text{ W/m}^2 \cdot \text{K} \times 0.00090 \text{ m}}{14.9 \text{ W/m} \cdot \text{K}} = 0.0009$$

The lumped capacitance approximation is valid.

Furthermore, since the Biot number is very small, the lumped capacitance approximation would certainly still be valid using a more conservative length estimate.

(c) Again, we will only calculate  $L_{c1}$ . There will be very little heat transfer to the stagnant air inside the tube, therefore in determining the surface area for convection heat transfer,  $A_s$ , only the outer surface area should be included. Thus,

$$L_{c1} = \frac{V}{A_s} = \frac{(W^2 - w^2)L}{4WL} = \frac{(24 \text{ mm})^2 - (20 \text{ mm})^2}{4 \times 24 \text{ mm}} = 1.83 \text{ mm}$$

The corresponding Biot number is

$$Bi_1 = \frac{hL_{c1}}{k} = \frac{37 \text{ W/m}^2 \cdot \text{K} \times 0.00183 \text{ m}}{177 \text{ W/m} \cdot \text{K}} = 3.8 \times 10^{-4}$$

The lumped capacitance approximation is valid.

Furthermore, since the Biot number is very small, the lumped capacitance approximation would certainly still be valid using a more conservative length estimate.

Continued...

### PROBLEM 5.5 (Cont.)

(d) We are not told which type of stainless steel this is, but we are told its mass, from which we can find its density:

$$\rho = \frac{M}{V} = \frac{M}{\pi D^2 L / 4} = \frac{0.328 \text{ kg}}{\pi (0.013 \text{ m})^2 \times 0.3 \text{ m} / 4} = 8237 \text{ kg/m}^3$$

This appears to be AISI 316 stainless steel, with a thermal conductivity of  $k = 13.4 \text{ W/m}\cdot\text{K}$  at  $T = 300 \text{ K}$ .

The characteristic lengths are

$$L_{c1} = \frac{V}{A_s} = \frac{\pi D^2 L / 4}{\pi DL + 2\pi D^2 / 4} = \frac{DL / 4}{L + D / 2} = \frac{13 \text{ mm} \times 300 \text{ mm} / 4}{300 \text{ mm} + 13 \text{ mm} / 2} = 3.18 \text{ mm} \quad <$$

$$L_{c2} = \text{Maximum center to surface distance} = D / 2 = 6.5 \text{ mm} \quad <$$

Notice that the surface area of the ends has been included in  $L_{c1}$ , and does have a small effect on the result. The corresponding Biot numbers are

$$Bi_1 = \frac{hL_{c1}}{k} = \frac{15 \text{ W/m}^2 \cdot \text{K} \times 0.00318 \text{ m}}{13.4 \text{ W/m} \cdot \text{K}} = 0.0036 \quad <$$

$$Bi_2 = \frac{hL_{c2}}{k} = \frac{15 \text{ W/m}^2 \cdot \text{K} \times 0.0065 \text{ m}}{13.4 \text{ W/m} \cdot \text{K}} = 0.0073 \quad <$$

The lumped capacitance approximation is valid according to either definition. <

(e) The characteristic lengths are

$$L_{c1} = \frac{V}{A_s} = \frac{\pi D^3 / 6}{\pi D^2} = \frac{D}{6} = 2 \text{ mm} \quad <$$

$$L_{c2} = \text{Maximum center to surface distance} = D / 2 = 6 \text{ mm} \quad <$$

Since heat transfer from the sphere is by radiation, we will calculate the effective radiation heat transfer coefficient (Equation 1.9):

$$\begin{aligned} h_r &= \varepsilon \sigma (T_s + T_{\text{sur}})(T_s^2 + T_{\text{sur}}^2) \\ &= 0.73 \times 5.67 \times 10^{-8} \text{ W/m}^2 \cdot \text{K}^4 [373 \text{ K} + 293 \text{ K}][(373 \text{ K})^2 + (293 \text{ K})^2] = 6.20 \text{ W/m}^2 \cdot \text{K} \end{aligned}$$

Continued...

### PROBLEM 5.5 (Cont.)

The surface temperature has been taken as the initial value, to give the largest possible heat transfer coefficient. The Biot numbers are

$$Bi_1 = \frac{h_r L_{c1}}{k} = \frac{6.2 \text{ W/m}^2 \cdot \text{K} \times 0.002 \text{ m}}{120 \text{ W/m} \cdot \text{K}} = 1.0 \times 10^{-4} \quad <$$

$$Bi_2 = \frac{h_r L_{c2}}{k} = \frac{6.2 \text{ W/m}^2 \cdot \text{K} \times 0.006 \text{ m}}{120 \text{ W/m} \cdot \text{K}} = 3.1 \times 10^{-4} \quad <$$

The lumped capacitance approximation is valid according to either definition. <

(f) The characteristic lengths are

$$L_{c1} = \frac{V}{A_s} = \frac{\pi D^2 L / 4}{\pi DL} = \frac{D}{4} = 5 \text{ mm} \quad <$$

$$L_{c2} = \text{Maximum center to surface distance} = D / 2 = 10 \text{ mm} \quad <$$

We are not told the convection heat transfer coefficient, but we do know the fluid temperature and the temperature of the rod initially and at  $t = 225 \text{ s}$ . If we assume that the lumped capacitance approximation is valid, we can determine the heat transfer coefficient from Equation 5.5:

$$\begin{aligned} h &= \frac{\rho V c}{A_s t} \ln\left(\frac{\theta_i}{\theta}\right) = \frac{\rho D c}{4t} \ln\left(\frac{T_i - T_\infty}{T - T_\infty}\right) \\ &= \frac{2300 \text{ kg/m}^3 \times 0.020 \text{ m} \times 1750 \text{ J/kg} \cdot \text{K}}{4 \times 225 \text{ s}} \ln\left(\frac{200^\circ\text{C} - 20^\circ\text{C}}{100^\circ\text{C} - 20^\circ\text{C}}\right) = 72.5 \text{ W/m}^2 \cdot \text{K} \end{aligned}$$

The resulting Biot numbers are:

$$Bi_1 = \frac{h L_{c1}}{k} = \frac{72.5 \text{ W/m}^2 \cdot \text{K} \times 0.005 \text{ m}}{16 \text{ W/m} \cdot \text{K}} = 0.023 \quad <$$

$$Bi_2 = \frac{h L_{c2}}{k} = \frac{72.5 \text{ W/m}^2 \cdot \text{K} \times 0.01 \text{ m}}{16 \text{ W/m} \cdot \text{K}} = 0.045 \quad <$$

The lumped capacitance approximation is valid according to either definition. <

This also means that it was appropriate to use the lumped capacitance approximation to calculate  $h$ .

Continued...

### PROBLEM 5.5 (Cont.)

(g) With the diameter increased by a factor of ten, so are the characteristic lengths:

$$L_{c1} = \frac{V}{A_s} = \frac{\pi D^2 L / 4}{\pi DL} = \frac{D}{4} = 50 \text{ mm} \quad <$$

$$L_{c2} = \text{Maximum center to surface distance} = D / 2 = 100 \text{ mm} \quad <$$

Once again, we assume that the lumped capacitance approximation is valid to calculate the heat transfer coefficient according to

$$\begin{aligned} h &= \frac{\rho V c}{A_s t} \ln\left(\frac{\theta_i}{\theta}\right) = \frac{\rho D c}{4t} \ln\left(\frac{T_i - T_\infty}{T - T_\infty}\right) \\ &= \frac{2300 \text{ kg/m}^3 \times 0.20 \text{ m} \times 1750 \text{ J/kg} \cdot \text{K}}{4 \times 225 \text{ s}} \ln\left(\frac{200^\circ\text{C} - 20^\circ\text{C}}{100^\circ\text{C} - 20^\circ\text{C}}\right) = 725 \text{ W/m}^2 \cdot \text{K} \end{aligned}$$

The resulting Biot numbers are:

$$Bi_1 = \frac{hL_{c1}}{k} = \frac{725 \text{ W/m}^2 \cdot \text{K} \times 0.05 \text{ m}}{16 \text{ W/m} \cdot \text{K}} = 2.3 \quad <$$

$$Bi_2 = \frac{hL_{c2}}{k} = \frac{725 \text{ W/m}^2 \cdot \text{K} \times 0.1 \text{ m}}{16 \text{ W/m} \cdot \text{K}} = 4.5 \quad <$$

The lumped capacitance approximation is *not* valid according to either definition. <

This means that the calculated value of  $h$  is incorrect, therefore the above values of the Biot number are incorrect. However, we can still conclude that the  $Bi$  number is too large for lumped capacitance to be valid by the following reasoning. If the lumped capacitance approximation were valid, then the calculated  $h$  would be correct, and its value would be small enough to result in  $Bi < 0.1$ . Since the calculated Biot number does not satisfy the criterion to use the lumped capacitance approximation, the initial assumption that the lumped capacitance method is valid must have been false.

**COMMENTS:** (1) The determination of whether or not the lumped capacitance approximation can be used is, to some degree, dependent on how much precision is required in a given application. If the Biot number is close to 0.1 and good precision is required, the spatial variation of the temperature should be accounted for. If the geometry is simple, the analytical solutions presented in the text may be appropriate. For complex geometries, a numerical solution is often required, using the finite difference or finite element method. (2) In Case (d), the type of stainless steel is inferred from knowledge of its density. The variation of  $k$  among the four stainless steels listed in Table A.1 is on the order of 10%. If the object temperature varies significantly with time, the thermal conductivity may vary by more than 10% as a result. In that case, evaluating  $k$  at an appropriate average temperature is at least as important as distinguishing the type of stainless steel.

### PROBLEM 5.6

**KNOWN:** Diameter and initial temperature of steel balls cooling in air.

**FIND:** Time required to cool to a prescribed temperature.

**SCHEMATIC:**

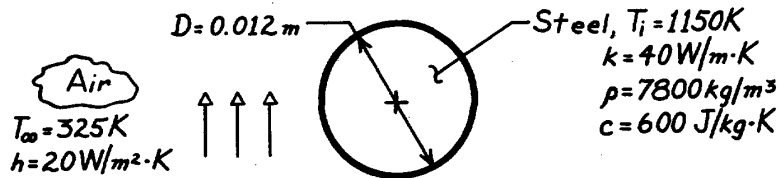

**ASSUMPTIONS:** (1) Negligible radiation effects, (2) Constant properties.

**ANALYSIS:** Applying Eq. 5.10 to a sphere ( $L_c = r_o/3$ ),

$$Bi = \frac{hL_c}{k} = \frac{h(r_o/3)}{k} = \frac{20 \text{ W/m}^2 \cdot \text{K} (0.002 \text{ m})}{40 \text{ W/m} \cdot \text{K}} = 0.001.$$

Hence, the temperature of the steel remains approximately uniform during the cooling process, and the lumped capacitance method may be used. From Eqs. 5.4 and 5.5,

$$t = \frac{\rho V c_p}{h A_s} \ln \frac{T_i - T_{\infty}}{T - T_{\infty}} = \frac{\rho (\pi D^3 / 6) c_p}{h \pi D^2} \ln \frac{T_i - T_{\infty}}{T - T_{\infty}}$$

$$t = \frac{7800 \text{ kg/m}^3 (0.012 \text{ m}) 600 \text{ J/kg} \cdot \text{K}}{6 \times 20 \text{ W/m}^2 \cdot \text{K}} \ln \frac{1150 - 325}{400 - 325}$$

$$t = 1122 \text{ s} = 0.312 \text{ h}$$

<

**COMMENTS:** Due to the large value of  $T_i$ , radiation effects are likely to be significant during the early portion of the transient. The effect is to shorten the cooling time.

## PROBLEM 5.7

**KNOWN:** Diameter and initial temperature of steel balls in air. Expression for the air temperature versus time.

**FIND:** (a) Expression for the sphere temperature,  $T(t)$ , (b) Graph of  $T(t)$  and explanation of special features.

**SCHEMATIC:**

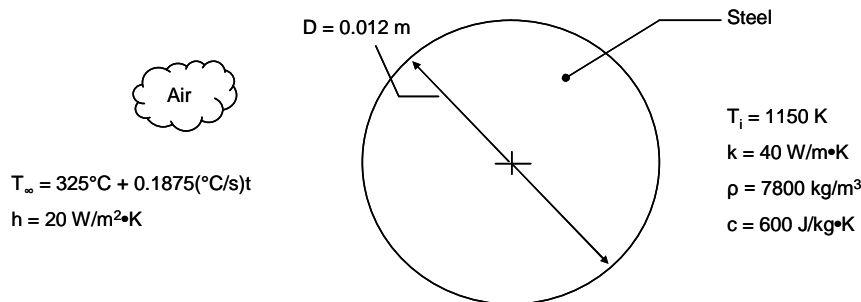

**ASSUMPTIONS:** (1) Constant properties, (2) Negligible radiation heat transfer.

**PROPERTIES:** Given:  $k = 40 \text{ W/m}\cdot\text{K}$ ,  $\rho = 7800 \text{ kg/m}^3$ ,  $c = 600 \text{ J/kg}\cdot\text{K}$ .

**ANALYSIS:**

(a) Applying Equation 5.10 to a sphere ( $L_c = r_o/3$ ),

$$B_i = \frac{hL_c}{k} = \frac{h(r_o/3)}{k} = \frac{20 \text{ W/m}^2 \cdot \text{K} (0.002 \text{ m})}{40 \text{ W/m} \cdot \text{K}} = 0.001$$

Hence, the temperature of the steel sphere remains approximately uniform during the cooling process. Equation 5.2 is written, with  $T_{\infty} = T_o + at$ , as

$$-hA_s(T - T_o - at) = \rho \forall c \frac{dT}{dt}$$

Letting  $\theta = T - T_o$ ,  $dT = d\theta$  and  $-hA_s(\theta - at) = \rho \forall c \frac{d\theta}{dt}$  or  $\frac{d\theta}{dt} = -C(\theta - at)$  where  $C = \frac{hA_s}{\rho \forall c}$

The solution may be written as the sum of the homogeneous and particular solutions,

$$\theta = \theta_h + \theta_p \quad \text{where} \quad \theta_h = c_1 \exp(-Ct).$$

Assuming  $\theta_p = f(t)\theta_h$ , we substitute into the differential equation to find

$$\frac{df}{dt} = C a t \exp(Ct) / c_1 \text{ from which } f = a(t - 1/C) \exp(Ct) / c_1.$$

Thus, the complete solution is

$\theta = c_1 \exp(-Ct) + a(t - 1/C)$  and applying the initial condition we find

$$T = (T_i - T_o + a/C) \exp(-Ct) + a(t - 1/C) + T_o$$

<

Continued...

### PROBLEM 5.7 (Cont.)

(b) The ambient and sphere temperatures for  $0 \leq t \leq 3600$  s are shown in the plot below.

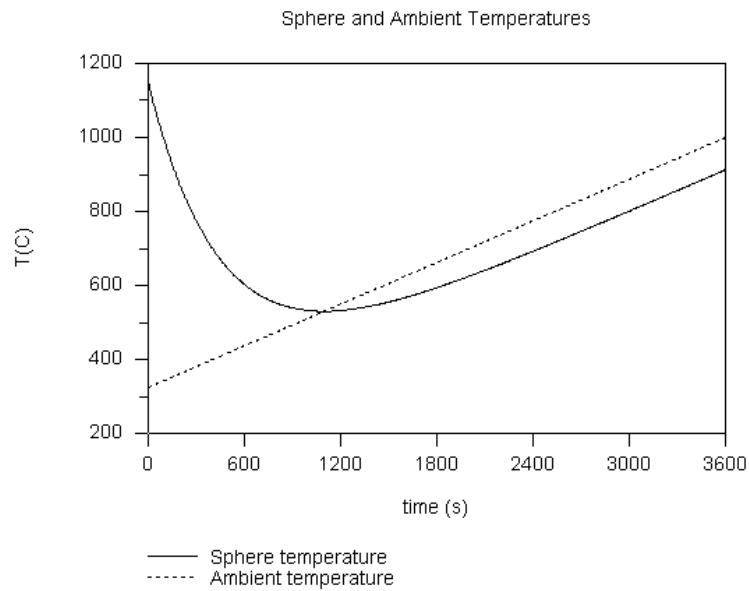

Note that:

- (1) For small times ( $t \leq 600$ s) the sphere temperature decreases rapidly,
- (2) at  $t \approx 1100$  s,  $T = T_\infty$  and, from Equation 5.2,  $dT/dt = 0$ ,
- (3) at  $t \geq 1100$  s,  $T < T_\infty$ ,
- (4) at large time,  $T - T_\infty$  and  $dT/dt$  are constant.

**COMMENTS:** Unless the air environment of Problem 5.6 is cooled, the air temperature will increase in temperature as energy is transferred from the balls. However, the actual air temperature versus time may not be linear.



### PROBLEM 5.8

**KNOWN:** The temperature-time history of a pure copper sphere in an air stream.

**FIND:** The heat transfer coefficient between the sphere and the air stream.

**SCHEMATIC:**

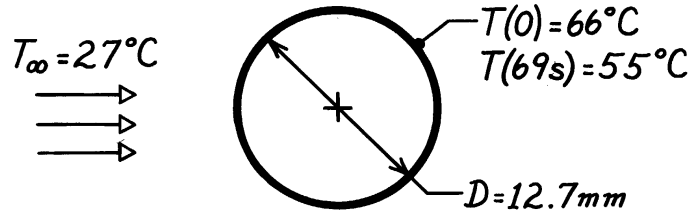

**ASSUMPTIONS:** (1) Temperature of sphere is spatially uniform, (2) Negligible radiation exchange, (3) Constant properties.

**PROPERTIES:** Table A-1, Pure copper (333K):  $\rho = 8933 \text{ kg/m}^3$ ,  $c_p = 389 \text{ J/kg}\cdot\text{K}$ ,  $k = 398 \text{ W/m}\cdot\text{K}$ .

**ANALYSIS:** The time-temperature history is given by Eq. 5.6 with Eq. 5.7.

$$\frac{\theta(t)}{\theta_i} = \exp\left(-\frac{t}{R_t C_t}\right) \quad \text{where} \quad R_t = \frac{1}{hA_s} \quad A_s = \pi D^2$$

$$C_t = \rho V c_p \quad V = \frac{\pi D^3}{6}$$

$$\theta = T - T_\infty.$$

Recognize that when  $t = 69\text{s}$ ,

$$\frac{\theta(t)}{\theta_i} = \frac{(55 - 27)^\circ\text{C}}{(66 - 27)^\circ\text{C}} = 0.718 = \exp\left(-\frac{t}{\tau_t}\right) = \exp\left(-\frac{69\text{s}}{\tau_t}\right)$$

and solving for  $\tau_t$  find

$$\tau_t = 208\text{s}.$$

Hence,

$$h = \frac{\rho V c_p}{A_s \tau_t} = \frac{8933 \text{ kg/m}^3 \left(\pi 0.0127^3 \text{ m}^3 / 6\right) 389 \text{ J/kg}\cdot\text{K}}{\pi 0.0127^2 \text{ m}^2 \times 208\text{s}}$$

$$h = 35.3 \text{ W/m}^2 \cdot \text{K}.$$

<

**COMMENTS:** Note that with  $L_c = D_o/6$ ,

$$Bi = \frac{hL_c}{k} = 35.3 \text{ W/m}^2 \cdot \text{K} \times \frac{0.0127}{6} \text{ m} / 398 \text{ W/m}\cdot\text{K} = 1.88 \times 10^{-4}.$$

Hence,  $Bi < 0.1$  and the spatially isothermal assumption is reasonable.

### PROBLEM 5.9

**KNOWN:** Solid steel sphere (AISI 1010), coated with dielectric layer of prescribed thickness and thermal conductivity. Coated sphere, initially at uniform temperature, is suddenly quenched in an oil bath.

**FIND:** Time required for sphere to reach 140°C.

**SCHEMATIC:**

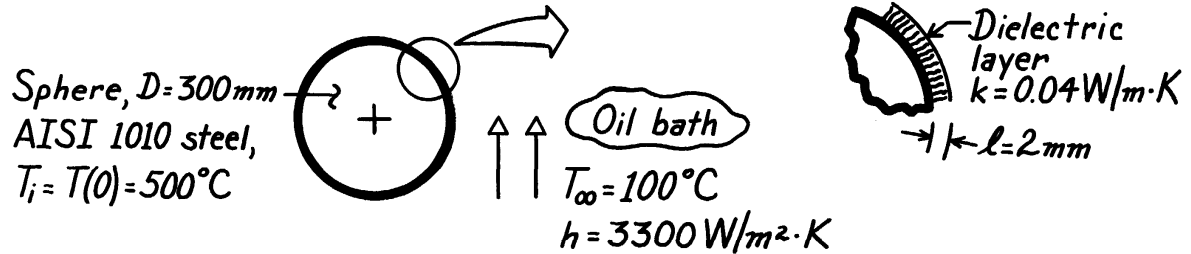

**PROPERTIES:** Table A-1, AISI 1010 Steel ( $\bar{T} = [500 + 140]^\circ\text{C}/2 = 320^\circ\text{C} \approx 600\text{K}$ ):

$$\rho = 7832\text{ kg/m}^3, \quad c = 559\text{ J/kg}\cdot\text{K}, \quad k = 48.8\text{ W/m}\cdot\text{K}.$$

**ASSUMPTIONS:** (1) Steel sphere is space-wise isothermal, (2) Dielectric layer has negligible thermal capacitance compared to steel sphere, (3) Layer is thin compared to radius of sphere, (4) Constant properties, (5) Neglect contact resistance between steel and coating.

**ANALYSIS:** The thermal resistance to heat transfer from the sphere is due to the dielectric layer and the convection coefficient. That is,

$$R'' = \frac{\ell}{k} + \frac{1}{h} = \frac{0.002\text{ m}}{0.04\text{ W/m}\cdot\text{K}} + \frac{1}{3300\text{ W/m}^2\cdot\text{K}} = (0.050 + 0.0003) = 0.0503 \frac{\text{m}^2\cdot\text{K}}{\text{W}},$$

or in terms of an overall coefficient,  $U = 1/R'' = 19.88\text{ W/m}^2\cdot\text{K}$ . The effective Biot number is

$$\text{Bi}_e = \frac{UL_c}{k} = \frac{U(r_o/3)}{k} = \frac{19.88\text{ W/m}^2\cdot\text{K} \times (0.300/6)\text{ m}}{48.8\text{ W/m}\cdot\text{K}} = 0.0204$$

where the characteristic length is  $L_c = r_o/3$  for the sphere. Since  $\text{Bi}_e < 0.1$ , the lumped capacitance approach is applicable. Hence, Eq. 5.5 is appropriate with  $h$  replaced by  $U$ ,

$$t = \frac{\rho c}{U} \left[ \frac{V}{A_s} \right] \ln \frac{\theta_i}{\theta_o} = \frac{\rho c}{U} \left[ \frac{V}{A_s} \right] \ln \frac{T(0) - T_\infty}{T(t) - T_\infty}.$$

Substituting numerical values with  $(V/A_s) = r_o/3 = D/6$ ,

$$t = \frac{7832\text{ kg/m}^3 \times 559\text{ J/kg}\cdot\text{K}}{19.88\text{ W/m}^2\cdot\text{K}} \left[ \frac{0.300\text{ m}}{6} \right] \ln \frac{(500 - 100)^\circ\text{C}}{(140 - 100)^\circ\text{C}}$$

$$t = 25,358\text{ s} = 7.04\text{ h}.$$

<

**COMMENTS:** (1) Note from calculation of  $R''$  that the resistance of the dielectric layer dominates and therefore nearly all the temperature drop occurs across the layer.

## PROBLEM 5.10

**KNOWN:** Thickness and properties of flaked food product. Conveyor length. Initial flake temperature. Ambient temperature and convection heat transfer coefficient. Final product temperature.

**FIND:** Required conveyor velocities for thick and thin flakes.

**SCHEMATIC:**

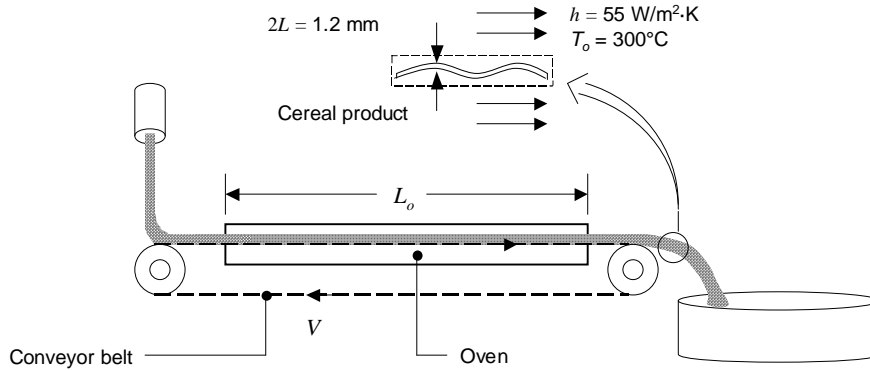

**ASSUMPTIONS:** (1) Constant properties. (2) Lumped capacitance behavior. (3) Negligible radiation heat transfer. (4) Negligible moisture evaporation from product. (5) Negligible conduction between flake and conveyor belt.

**PROPERTIES:** Flake:  $\rho = 700 \text{ kg/m}^3$ ,  $c_p = 2400 \text{ J/kg}\cdot\text{K}$ , and  $k = 0.34 \text{ W/m}\cdot\text{K}$ .

**ANALYSIS:** The Biot number is

$$Bi = \frac{hL}{k} = \frac{55 \text{ W/m}^2 \cdot \text{K} \times 0.6 \times 10^{-3} \text{ m}}{0.34 \text{ W/m}\cdot\text{K}} = 0.098$$

Hence the lumped capacitance assumption is valid. The required heating time is

$$t = \frac{\rho V c}{h A_s} \ln \frac{\theta_i}{\theta} = \frac{\rho L c}{h} \ln \frac{\theta_i}{\theta} = \frac{700 \text{ kg/m}^3 \times 0.6 \times 10^{-3} \text{ m} \times 2400 \text{ J/kg}\cdot\text{K}}{55 \text{ W/m}^2 \cdot \text{K}} \ln \frac{(20 - 300)}{(220 - 300)} = 23 \text{ s}$$

Therefore the required conveyor velocity is  $V = L_o/t = 3\text{m}/23\text{s} = 0.13 \text{ m/s}$ . <

If the flake thickness is reduced to  $2L = 1 \text{ mm}$ , the lumped capacitance approximation remains valid and the heating time is 19 s. The associated conveyor velocity is 0.16 m/s. <

**COMMENTS:** (1) Assuming large surroundings, a representative value of the radiation heat transfer coefficient is  $h_r = \sigma (T_i + T_o)(T_i^2 + T_o^2) = 5.67 \times 10^{-8} \text{ W/m}^2 \cdot \text{K}^4 (293 + 573)(293^2 + 573^2) \text{ K}^4 = 20.3$

$\text{W/m}^2\cdot\text{K}$ . Radiation heat transfer would be significant and would serve to increase the product heating rate, increasing the allowable conveyor belt speed. (2) The food product is likely to enter the oven in a moist state. Additional thermal energy would be required to remove the moisture during heating, reducing the rate at which the product temperature increases. (3) The effects noted in Comments 1 and 2 would tend to offset each other. A detailed analysis would be required to assess the impact of radiation and evaporation on the required conveyor velocity.

### PROBLEM 5.11

**KNOWN:** Thickness, surface area, and properties of iron base plate. Heat flux at inner surface. Temperature of surroundings. Temperature and convection coefficient of air at outer surface.

**FIND:** Time required for plate to reach a temperature of 135°C. Operating efficiency of iron.

**SCHEMATIC:**

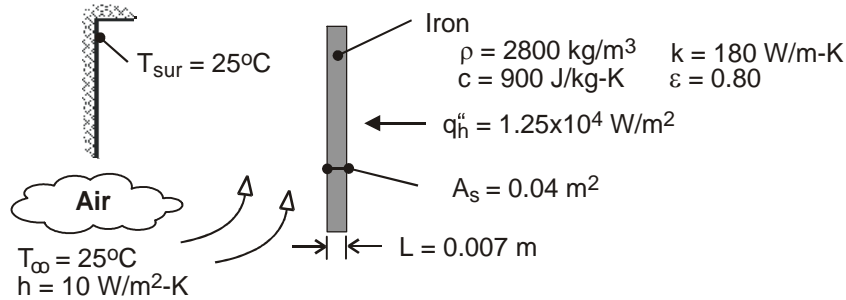

**ASSUMPTIONS:** (1) Radiation exchange is between a small surface and large surroundings, (2) Convection coefficient is independent of time, (3) Constant properties, (4) Iron is initially at room temperature ( $T_i = T_\infty$ ).

**ANALYSIS:** Biot numbers may be based on convection heat transfer and/or the maximum heat transfer by radiation, which would occur when the plate reaches the desired temperature ( $T = 135^\circ\text{C}$ ).

From Eq. (1.9) the corresponding radiation transfer coefficient is  $h_r = \epsilon\sigma(T + T_{\text{sur}})(T^2 + T_{\text{sur}}^2) = 0.8 \times 5.67 \times 10^{-8} \text{ W/m}^2 \cdot \text{K}^4 (408 + 298) \text{ K} (408^2 + 298^2) \text{ K}^2 = 8.2 \text{ W/m}^2 \cdot \text{K}$ . Hence,

$$\text{Bi} = \frac{hL}{k} = \frac{10 \text{ W/m}^2 \cdot \text{K} (0.007 \text{ m})}{180 \text{ W/m} \cdot \text{K}} = 3.9 \times 10^{-4}$$

$$\text{Bi}_r = \frac{h_r L}{k} = \frac{8.2 \text{ W/m}^2 \cdot \text{K} (0.007 \text{ m})}{180 \text{ W/m} \cdot \text{K}} = 3.2 \times 10^{-4}$$

With convection and radiation considered independently or collectively,  $\text{Bi}$ ,  $\text{Bi}_r$ ,  $\text{Bi} + \text{Bi}_r \ll 1$  and the lumped capacitance analysis may be used.

The energy balance, Eq. (5.15), associated with Figure 5.5 may be applied to this problem. With  $\dot{E}_g = 0$ , the integral form of the equation is

$$T - T_i = \frac{A_s}{\rho V c} \int_0^t \left[ q_h'' - h(T - T_\infty) - \epsilon\sigma(T^4 - T_{\text{sur}}^4) \right] dt$$

Integrating numerically, we obtain, for  $T = 135^\circ\text{C}$ ,

$$t = 168 \text{ s}$$

<

**COMMENTS:** Note that, if heat transfer is by natural convection,  $h$ , like  $h_r$ , will vary during the process from a value of 0 at  $t = 0$  to a maximum at  $t = 168 \text{ s}$ .

## PROBLEM 5.12

**KNOWN:** Diameter, density, specific heat and thermal conductivity of aluminum spheres used in packed bed thermal energy storage system. Convection coefficient and inlet gas temperature.

**FIND:** Time required for sphere to acquire 90% of maximum possible thermal energy and the corresponding center temperature. Potential advantage of using copper in lieu of aluminum.

**SCHEMATIC:**

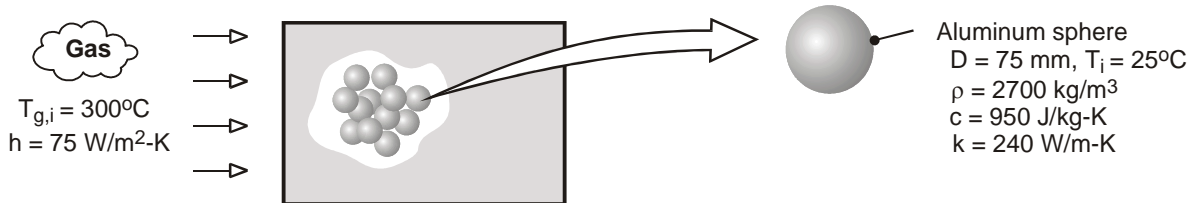

**ASSUMPTIONS:** (1) Negligible heat transfer to or from a sphere by radiation or conduction due to contact with other spheres, (2) Constant properties.

**ANALYSIS:** To determine whether a lumped capacitance analysis can be used, first compute  $Bi = h(r_o/3)/k = 75 \text{ W/m}^2 \cdot \text{K} (0.025\text{m})/240 \text{ W/m} \cdot \text{K} = 0.013 < 0.1$ . Hence, the lumped capacitance approximation may be made, and a uniform temperature may be assumed to exist in the sphere at any time. From Eq. 5.8a, achievement of 90% of the maximum possible thermal energy storage corresponds to

$$\frac{Q}{\rho c V \theta_i} = 0.90 = 1 - \exp(-t / \tau_t)$$

where  $\tau_t = \rho V c / h A_s = \rho D c / 6 h = 2700 \text{ kg/m}^3 \times 0.075 \text{ m} \times 950 \text{ J/kg} \cdot \text{K} / 6 \times 75 \text{ W/m}^2 \cdot \text{K} = 427 \text{ s}$ . Hence,

$$t = -\tau_t \ln(0.1) = 427 \text{ s} \times 2.30 = 984 \text{ s} \quad <$$

From Eq. (5.6), the corresponding temperature at any location in the sphere is

$$T(984 \text{ s}) = T_{g,i} + (T_i - T_{g,i}) \exp(-6ht / \rho D c)$$

$$T(984 \text{ s}) = 300^\circ\text{C} - 275^\circ\text{C} \exp\left(-6 \times 75 \text{ W/m}^2 \cdot \text{K} \times 984 \text{ s} / 2700 \text{ kg/m}^3 \times 0.075 \text{ m} \times 950 \text{ J/kg} \cdot \text{K}\right)$$

$$T(984 \text{ s}) = 272.5^\circ\text{C} \quad <$$

Obtaining the density and specific heat of copper from Table A-1, we see that  $(\rho c)_{\text{Cu}} \approx 8900 \text{ kg/m}^3 \times 400 \text{ J/kg} \cdot \text{K} = 3.56 \times 10^6 \text{ J/m}^3 \cdot \text{K} > (\rho c)_{\text{Al}} = 2.57 \times 10^6 \text{ J/m}^3 \cdot \text{K}$ . Hence, for an equivalent sphere diameter, the copper can store approximately 38% more thermal energy than the aluminum.

**COMMENTS:** Before the packed bed becomes fully charged, the temperature of the gas decreases as it passes through the bed. Hence, the time required for a sphere to reach a prescribed state of thermal energy storage increases with increasing distance from the bed inlet.

### PROBLEM 5.13

**KNOWN:** Wafer, initially at 100°C, is suddenly placed on a chuck with uniform and constant temperature, 23°C. Wafer temperature after 15 seconds is observed as 33°C.

**FIND:** (a) Contact resistance,  $R''_{tc}$ , between interface of wafer and chuck through which helium slowly flows, and (b) Whether  $R''_{tc}$  will change if air, rather than helium, is the purge gas.

**SCHEMATIC:**

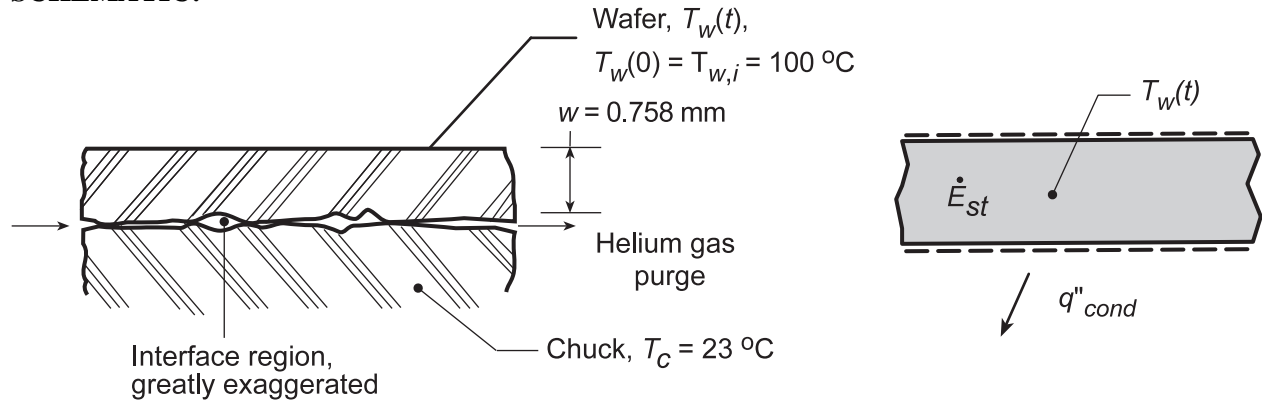

**PROPERTIES:** Wafer (silicon, typical values):  $\rho = 2700 \text{ kg/m}^3$ ,  $c = 875 \text{ J/kg}\cdot\text{K}$ ,  $k = 177 \text{ W/m}\cdot\text{K}$ .

**ASSUMPTIONS:** (1) Wafer behaves as a space-wise isothermal object, (2) Negligible heat transfer from wafer top surface, (3) Chuck remains at uniform temperature, (4) Thermal resistance across the interface is due to conduction effects, not convective, (5) Constant properties.

**ANALYSIS:** (a) Perform an energy balance on the wafer as shown in the Schematic.

$$\dot{E}''_{in} - \dot{E}''_{out} + \dot{E}_g = \dot{E}_{st} \quad (1)$$

$$-q''_{cond} = \dot{E}_{st} \quad (2)$$

$$-\frac{T_w(t) - T_c}{R''_{tc}} = \rho w c \frac{dT_w}{dt} \quad (3)$$

Separate and integrate Eq. (3)

$$-\int_0^t \frac{dt}{\rho w c R''_{tc}} = \int_{T_{wi}}^{T_w} \frac{dT_w}{T_w - T_c} \quad (4) \quad \frac{T_w(t) - T_c}{T_{wi} - T_c} = \exp\left[-\frac{t}{\rho w c R''_{tc}}\right] \quad (5)$$

Substituting numerical values for  $T_w(15s) = 33^\circ\text{C}$ ,

$$\frac{(33 - 23)^\circ\text{C}}{(100 - 23)^\circ\text{C}} = \exp\left[-\frac{15\text{s}}{2700 \text{ kg/m}^3 \times 0.758 \times 10^{-3} \text{ m} \times 875 \text{ J/kg}\cdot\text{K} \times R''_{tc}}\right] \quad (6)$$

$$R''_{tc} = 0.0041 \text{ m}^2 \cdot \text{K/W} \quad <$$

(b)  $R''_{tc}$  will increase since  $k_{air} < k_{helium}$ . See Table A.4.

**COMMENTS:** Note that  $Bi = R_{int}/R_{ext} = (w/k)/R''_{tc} = 0.001$ . Hence the spacewise isothermal assumption is reasonable.

### PROBLEM 5.14

**KNOWN:** Thickness and initial temperature of copper sheet. Dependence of the convection heat transfer coefficient on sheet temperature.

**FIND:** Time required to reach sheet temperature of  $\bar{T} = 102^\circ\text{C}$ .

**SCHEMATIC:**

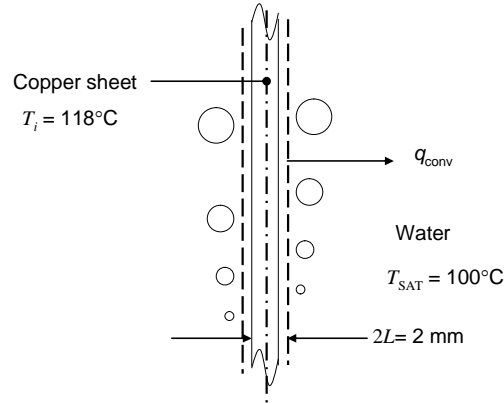

**ASSUMPTIONS:** (1) Constant properties. (2) Lumped capacitance behavior.

**PROPERTIES:** Table A.1, copper ( $T = 383\text{ K}$ ):  $\rho = 8933\text{ kg/m}^3$ ,  $c = 394\text{ J/kg}\cdot\text{K}$ , and  $k = 394\text{ W/m}\cdot\text{K}$ .

**ANALYSIS:** Since  $h = 1010\text{ W/m}^2\cdot\text{K}^3(T - T_{\text{sat}})^2$  the values of  $C$  and  $n$  in Equation 5.26 are  $1010\text{ W/m}^2\cdot\text{K}^3$  and 2, respectively. Equation 5.27 becomes

$$\frac{dT}{dt} = -\frac{CA_{s,c}(T - T_{\text{sat}})^3}{\rho Vc} = -\frac{C(T - T_{\text{sat}})^3}{L\rho c}$$

or

$$\int_{T_i}^T (T - T_{\text{sat}})^{-3} dT = -\int_0^t \frac{C}{L\rho c} dt$$

so that

$$\frac{L\rho c}{C} \left[ \frac{(T - T_{\text{sat}})^{-2}}{2} - \frac{(T_i - T_{\text{sat}})^{-2}}{2} \right] = t$$

Substituting values,

$$t = \frac{1 \times 10^{-3}\text{ m} \times 8933\text{ kg/m}^3 \times 394\text{ J/kg}\cdot\text{K}}{1010\text{ W/m}^2\cdot\text{K}^3} \left[ \frac{(T - 100^\circ\text{C})^{-2}}{2} - \frac{(118^\circ\text{C} - 100^\circ\text{C})^{-2}}{2} \right] \quad (1)$$

For  $T = 102^\circ\text{C}$ ,  $t = 0.43\text{ s}$

<  
Continued...

### PROBLEM 5.14 (Cont.)

The heat transfer coefficient at  $\bar{T} = 110^\circ\text{C}$  is  $\bar{h} = 1010 \text{ W/m}^2 \cdot \text{K}^3 \times (10 \text{ K})^2 = 101,000 \text{ W/m}^2 \cdot \text{K}$ . Hence, for the case where the heat transfer coefficient is constant Equation 5.6 becomes

$$t = \frac{\rho L c}{\bar{h}} \ln \left[ \frac{T_i - T_{\text{sat}}}{T - T_{\text{sat}}} \right] = \frac{8933 \text{ kg/m}^3 \times 1 \times 10^{-3} \text{ m} \times 394 \text{ J/kg} \cdot \text{K}}{101,000 \text{ W/m}^2 \cdot \text{K}} \ln \left[ \frac{118^\circ\text{C} - 100^\circ\text{C}}{T - 100^\circ\text{C}} \right] \quad (2)$$

Equations (1) and (2) may be solved for time-dependence of the plate temperature to yield

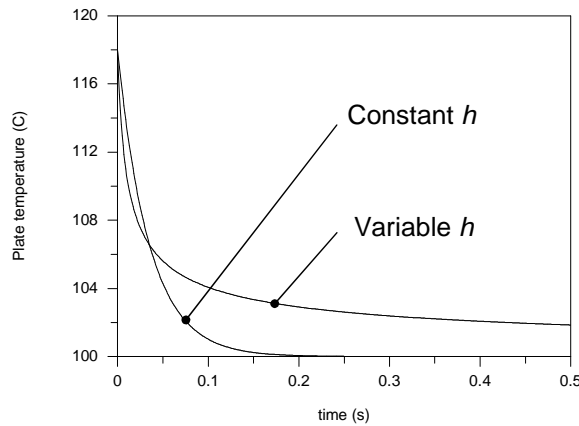

The convection heat transfer coefficient is initially relatively high and decays as the temperature difference between the plate and the water decreases. If the convection heat transfer coefficient is evaluated at the average plate temperature, the heat transfer coefficient is initially under-predicted, leading to a slower plate cooling rate at early times. However, the convection coefficient is over-predicted at later times, leading to an unrealistic high cooling rate as evident in the graph.

**COMMENTS:** (1) The time could also be calculated by solving Equation 5.28.

(2) The Biot number based upon the average heat transfer coefficient is

$$Bi = \frac{\bar{h}L}{k} = \frac{101,000 \text{ W/m}^2 \cdot \text{K} \times 1 \times 10^{-3} \text{ m}}{394 \text{ W/m} \cdot \text{K}} = 0.25. \text{ The lumped capacitance approximation is not valid at}$$

early times. However, the trends evident in the comparison of the variable versus constant heat transfer coefficients would also occur if spatial temperature gradients were accounted for.



### PROBLEM 5.15

**KNOWN:** Diameter and radial temperature of AISI 1010 carbon steel shaft. Convection coefficient and temperature of furnace gases.

**FIND:** Time required for shaft centerline to reach a prescribed temperature.

**SCHEMATIC:**

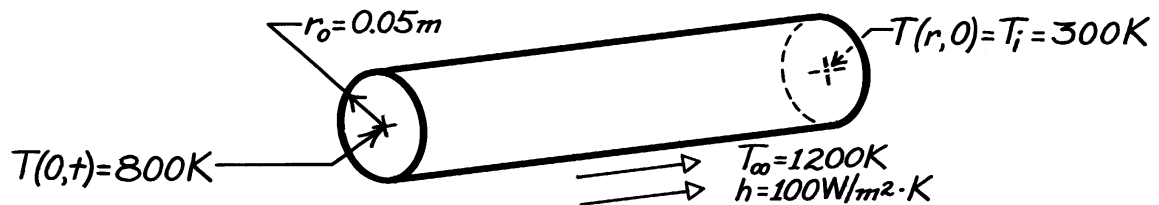

**ASSUMPTIONS:** (1) One-dimensional, radial conduction, (2) Constant properties.

**PROPERTIES:** AISI 1010 carbon steel, *Table A.1* ( $\bar{T} = 550\text{ K}$ ):  $\rho = 7832\text{ kg/m}^3$ ,  $k = 51.2\text{ W/m}\cdot\text{K}$ ,  $c = 541\text{ J/kg}\cdot\text{K}$ ,  $\alpha = 1.21 \times 10^{-5}\text{ m}^2/\text{s}$ .

**ANALYSIS:** The Biot number is

$$Bi = \frac{hr_o/2}{k} = \frac{100\text{ W/m}^2 \cdot \text{K}(0.05\text{ m}/2)}{51.2\text{ W/m}\cdot\text{K}} = 0.0488.$$

Hence, the lumped capacitance method can be applied. From Equation 5.6,

$$\frac{T - T_\infty}{T_i - T_\infty} = \exp\left[-\left(\frac{hAs}{\rho Vc}\right)t\right] = \exp\left[-\frac{4h}{\rho cD}t\right]$$

$$\ln\left(\frac{800 - 1200}{300 - 1200}\right) = -0.811 = -\frac{4 \times 100\text{ W/m}^2 \cdot \text{K}}{7832\text{ kg/m}^3 (541\text{ J/kg}\cdot\text{K}) 0.1\text{ m}}t$$

$$t = 859\text{ s.}$$

<

**COMMENTS:** To check the validity of the foregoing result, use the one-term approximation to the series solution. From Equation 5.52c,

$$\frac{T_o - T_\infty}{T_i - T_\infty} = \frac{-400}{-900} = 0.444 = C_1 \exp\left(-\zeta_1^2 Fo\right)$$

For  $Bi = hr_o/k = 0.0976$ , Table 5.1 yields  $\zeta_1 = 0.436$  and  $C_1 = 1.024$ . Hence

$$\frac{-(0.436)^2 (1.2 \times 10^{-5}\text{ m}^2/\text{s})}{(0.05\text{ m})^2}t = \ln(0.434) = -0.835$$

$$t = 915\text{ s.}$$

The results agree to within 6%. The lumped capacitance method underestimates the actual time, since the response at the centerline lags that at any other location in the shaft.

### PROBLEM 5.16

**KNOWN:** Configuration, initial temperature and charging conditions of a thermal energy storage unit.

**FIND:** Time required to achieve 75% of maximum possible energy storage. Temperature of storage medium at this time.

**SCHEMATIC:**

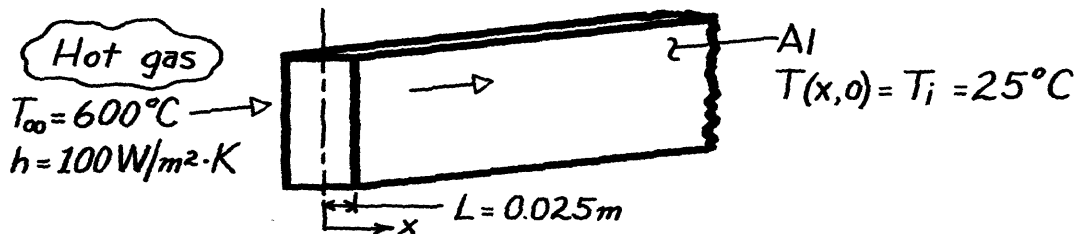

**ASSUMPTIONS:** (1) One-dimensional conduction, (2) Constant properties, (3) Negligible radiation exchange with surroundings.

**PROPERTIES:** Table A-1, Aluminum, pure ( $\bar{T} \approx 600\text{K} = 327^\circ\text{C}$ ):  $k = 231\text{ W/m}\cdot\text{K}$ ,  $c = 1033\text{ J/kg}\cdot\text{K}$ ,  $\rho = 2702\text{ kg/m}^3$ .

**ANALYSIS:** Recognizing the characteristic length is the half thickness, find

$$Bi = \frac{hL}{k} = \frac{100\text{ W/m}^2 \cdot \text{K} \times 0.025\text{ m}}{231\text{ W/m}\cdot\text{K}} = 0.011.$$

Hence, the lumped capacitance method may be used. From Eq. 5.8,

$$Q = (\rho Vc)\theta_i [1 - \exp(-t/\tau_t)] = -\Delta E_{st} \quad (1)$$

$$-\Delta E_{st, \max} = (\rho Vc)\theta_i. \quad (2)$$

Dividing Eq. (1) by (2),

$$\Delta E_{st} / \Delta E_{st, \max} = 1 - \exp(-t/\tau_{th}) = 0.75.$$

$$\text{Solving for } \tau_{th} = \frac{\rho Vc}{hA_s} = \frac{\rho Lc}{h} = \frac{2702\text{ kg/m}^3 \times 0.025\text{ m} \times 1033\text{ J/kg}\cdot\text{K}}{100\text{ W/m}^2 \cdot \text{K}} = 698\text{ s}.$$

Hence, the required time is

$$-\exp(-t/698\text{ s}) = -0.25 \quad \text{or} \quad t = 968\text{ s}. \quad <$$

From Eq. 5.6,

$$\frac{T - T_\infty}{T_i - T_\infty} = \exp(-t/\tau_{th})$$

$$T = T_\infty + (T_i - T_\infty) \exp(-t/\tau_{th}) = 600^\circ\text{C} - (575^\circ\text{C}) \exp(-968/698)$$

$$T = 456^\circ\text{C}. \quad <$$

**COMMENTS:** For the prescribed temperatures, the property temperature dependence is significant and some error is incurred by assuming constant properties. However, selecting properties at 600K was reasonable for this estimate.

## PROBLEM 5.17

**KNOWN:** Diameter and properties of neutrally-buoyant spherical particles.

**FIND:** Time constant of the particles.

**SCHEMATIC:**

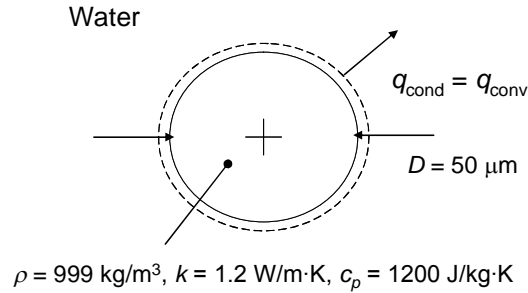

**ASSUMPTIONS:** (1) Constant properties. (2) Infinite medium. (3) Lumped capacitance behavior.

**PROPERTIES:** Particle:  $\rho = 999 \text{ kg/m}^3, k_p = 1.2 \text{ W/m}\cdot\text{K}$ , and  $c_p = 1200 \text{ J/kg}\cdot\text{K}$ . Table A.6 water ( $T = 300 \text{ K}$ ):  $k = 0.613 \text{ W/m}\cdot\text{K}$ .

**ANALYSIS:** Treating heat transfer between the particle and water as conduction, we may use the shape factor corresponding to Case 1 of Table 4.1 with  $z \rightarrow \infty$ . Hence

$$S = 2\pi D \quad (1)$$

The surface energy balance may be expressed as

$$q = Sk(T - T_\infty) = hA(T - T_\infty) = h\pi D^2(T - T_\infty)$$

where  $h$  is an effective heat transfer coefficient from which

$$h = \frac{Sk}{\pi D^2} = 2 \frac{k}{D} \quad (2)$$

The thermal time constant is

$$\tau_t = \left( \frac{1}{hA_s} \right) (\rho V c_p) \quad (3)$$

Combining Equations (1) through (3) yields

$$\tau_t = \frac{\rho c D^2}{12k} = \frac{999 \text{ kg/m}^3 \times 1200 \text{ J/kg}\cdot\text{K} \times (50 \times 10^{-6} \text{ m})^2}{12 \times 0.613 \text{ W/m}\cdot\text{K}} = 407 \times 10^{-6} \text{ s} <$$

**COMMENTS:** (1) The Biot number is  $Bi = hL_c/k_p = hD/6k_p = k/3k_p = 0.613 \text{ W/m}\cdot\text{K}/(3 \times 1.2 \text{ W/m}\cdot\text{K}) = 0.17$ . Lumped capacitance behavior will not exist in the particle and the analysis must be viewed as approximate. (2) Regardless of whether the lumped capacitance approximation is valid, the thermal time constant is relatively small. Hence an assumption that the particle temperature is the same as that of the surrounding water may be valid.

### PROBLEM 5.18

**KNOWN:** Inner diameter and wall thickness of a spherical, stainless steel vessel. Initial temperature, density, specific heat and heat generation rate of reactants in vessel. Convection conditions at outer surface of vessel.

**FIND:** (a) Temperature of reactants after one hour of reaction time, (b) Effect of convection coefficient on thermal response of reactants.

**SCHEMATIC:**

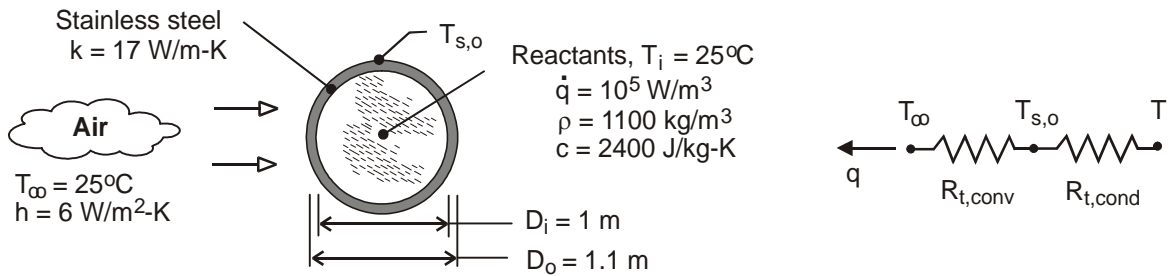

**ASSUMPTIONS:** (1) Temperature of well stirred reactants is uniform at any time and is equal to inner surface temperature of vessel ( $T = T_{s,i}$ ), (2) Thermal capacitance of vessel may be neglected, (3) Negligible radiation exchange with surroundings, (4) Constant properties.

**ANALYSIS:** (a) Transient thermal conditions within the reactor may be determined from Eq. (5.25), which reduces to the following form for  $T_i - T_\infty = 0$ .

$$T = T_\infty + (b/a) [1 - \exp(-at)]$$

where  $a = UA/\rho Vc$  and  $b = \dot{E}_g / \rho Vc = \dot{q} / \rho c$ . From Eq. (3.19) the product of the overall heat transfer coefficient and the surface area is  $UA = (R_{\text{cond}} + R_{\text{conv}})^{-1}$ , where from Eqs. (3.41) and (3.9),

$$R_{t,\text{cond}} = \frac{1}{2\pi k} \left( \frac{1}{D_i} - \frac{1}{D_o} \right) = \frac{1}{2\pi (17 \text{ W/m}\cdot\text{K})} \left( \frac{1}{1.0\text{m}} - \frac{1}{1.1\text{m}} \right) = 8.51 \times 10^{-4} \text{ K/W}$$

$$R_{t,\text{conv}} = \frac{1}{hA_o} = \frac{1}{(6 \text{ W/m}^2 \cdot \text{K}) \pi (1.1\text{m})^2} = 0.0438 \text{ K/W}$$

Hence,  $UA = 22.4 \text{ W/K}$ . It follows that, with  $v = \pi D_i^3 / 6$ ,

$$a = \frac{UA}{\rho Vc} = \frac{6(22.4 \text{ W/K})}{1100 \text{ kg/m}^3 \times \pi (1\text{m})^3 \times 2400 \text{ J/kg}\cdot\text{K}} = 1.620 \times 10^{-5} \text{ s}^{-1}$$

$$b = \frac{\dot{q}}{\rho c} = \frac{10^4 \text{ W/m}^3}{1100 \text{ kg/m}^3 \times 2400 \text{ J/kg}\cdot\text{K}} = 3.788 \times 10^{-3} \text{ K/s}$$

With  $(b/a) = 233.8^\circ\text{C}$  and  $t = 18,000\text{s}$ ,

$$T = 25^\circ\text{C} + 233.8^\circ\text{C} \left[ 1 - \exp\left(-1.62 \times 10^{-5} \text{ s}^{-1} \times 18,000\text{s}\right) \right] = 84.1^\circ\text{C} \quad <$$

Neglecting the thermal capacitance of the vessel wall, the heat rate by conduction through the wall is equal to the heat transfer by convection from the outer surface, and from the thermal circuit, we know that

Continued ...

**PROBLEM 5.18 (Cont.)**

$$\frac{T - T_{s,o}}{T_{s,o} - T_{\infty}} = \frac{R_{t,cond}}{R_{t,conv}} = \frac{8.51 \times 10^{-4} \text{ K/W}}{0.0438 \text{ K/W}} = 0.0194$$

$$T_{s,o} = \frac{T + 0.0194 T_{\infty}}{1.0194} = \frac{84.1^{\circ}\text{C} + 0.0194(25^{\circ}\text{C})}{1.0194} = 83.0^{\circ}\text{C}$$

<

(b) Representative low and high values of  $h$  could correspond to  $2 \text{ W/m}^2 \cdot \text{K}$  and  $100 \text{ W/m}^2 \cdot \text{K}$  for free and forced convection, respectively. Calculations based on Eq. (5.25) yield the following temperature histories.

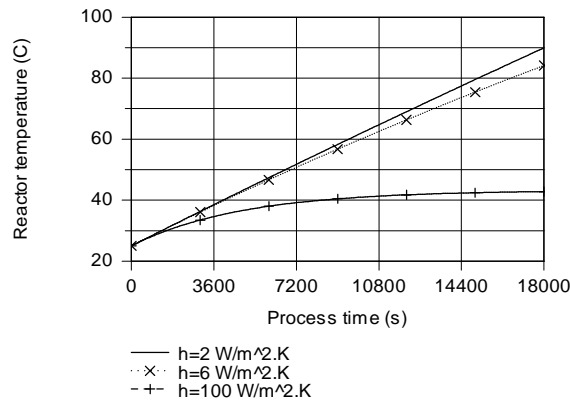

Forced convection is clearly an effective means of reducing the temperature of the reactants and accelerating the approach to steady-state conditions.

**COMMENTS:** The validity of neglecting thermal energy storage effects for the vessel may be assessed by contrasting its thermal capacitance with that of the reactants. Selecting values of  $\rho = 8000 \text{ kg/m}^3$  and  $c = 475 \text{ J/kg} \cdot \text{K}$  for stainless steel from Table A-1, the thermal capacitance of the vessel is  $C_{t,v} = (\rho V c)_{st} = 6.57 \times 10^5 \text{ J/K}$ , where  $V = (\pi/6)(D_o^3 - D_i^3)$ . With  $C_{t,r} = (\rho V c)_r = 2.64 \times 10^6 \text{ J/K}$  for the reactants,  $C_{t,r}/C_{t,v} \approx 4$ . Hence, the capacitance of the vessel is not negligible and should be considered in a more refined analysis of the problem.

## PROBLEM 5.19

**KNOWN:** Volume, density and specific heat of chemical in a stirred reactor. Temperature and convection coefficient associated with saturated steam flowing through submerged coil. Tube diameter and outer convection coefficient of coil. Initial and final temperatures of chemical and time span of heating process.

**FIND:** Required length of submerged tubing. Minimum allowable steam flowrate.

**SCHEMATIC:**

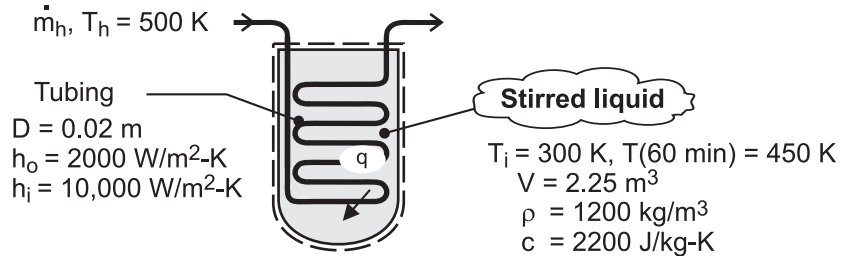

**ASSUMPTIONS:** (1) Constant properties, (2) Negligible heat loss from vessel to surroundings, (3) Chemical is isothermal, (4) Negligible work due to stirring, (5) Negligible thermal energy generation (or absorption) due to chemical reactions associated with the batch process, (6) Negligible tube wall conduction resistance, (7) Negligible kinetic energy, potential energy, and flow work changes for steam.

**ANALYSIS:** Heating of the chemical can be treated as a transient, lumped capacitance problem, wherein heat transfer from the coil is balanced by the increase in thermal energy of the chemical. Hence, conservation of energy yields

$$\frac{dU}{dt} = \rho V c \frac{dT}{dt} = U A_s (T_h - T)$$

Integrating, 
$$\int_{T_i}^T \frac{dT}{T_h - T} = \frac{U A_s}{\rho V c} \int_0^t dt$$

$$-\ln \frac{T_h - T}{T_h - T_i} = \frac{U A_s t}{\rho V c}$$

$$A_s = -\frac{\rho V c}{U t} \ln \frac{T_h - T}{T_h - T_i} \quad (1)$$

$$U = (h_i^{-1} + h_o^{-1})^{-1} = [(1/10,000) + (1/2000)]^{-1} \text{ W/m}^2 \cdot \text{K}$$

$$U = 1670 \text{ W/m}^2 \cdot \text{K}$$

$$A_s = -\frac{(1200 \text{ kg/m}^3)(2.25 \text{ m}^3)(2200 \text{ J/kg} \cdot \text{K})}{(1670 \text{ W/m}^2 \cdot \text{K})(3600 \text{ s})} \ln \frac{500 - 450}{500 - 300} = 1.37 \text{ m}^2$$

$$L = \frac{A_s}{\pi D} = \frac{1.37 \text{ m}^2}{\pi(0.02 \text{ m})} = 21.8 \text{ m} \quad <$$

**COMMENTS:** Eq. (1) could also have been obtained by adapting Eq. (5.5) to the conditions of this problem, with  $T_\infty$  and  $h$  replaced by  $T_h$  and  $U$ , respectively.

### PROBLEM 5.20

**KNOWN:** Electronic device on aluminum, finned heat sink modeled as spatially isothermal object with internal generation and convection from its surface.

**FIND:** (a) Temperature response after device is energized, (b) Temperature rise for prescribed conditions after 5 min.

**SCHEMATIC:**

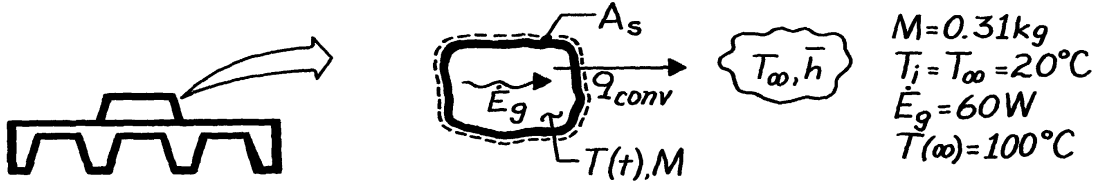

**ASSUMPTIONS:** (1) Spatially isothermal object, (2) Object is primarily aluminum, (3) Initially, object is in equilibrium with surroundings at  $T_\infty$ .

**PROPERTIES:** Table A-1, Aluminum, pure ( $\bar{T} = (20 + 100)^\circ \text{C} / 2 \approx 333 \text{K}$ ):  $c = 918 \text{ J/kg}\cdot\text{K}$ .

**ANALYSIS:** (a) Following the general analysis of Section 5.3, apply the conservation of energy requirement to the object,

$$\dot{E}_{\text{in}} + \dot{E}_g - \dot{E}_{\text{out}} = \dot{E}_{\text{st}} \quad \dot{E}_g - \bar{h}A_s(T - T_\infty) = Mc \frac{dT}{dt} \quad (1)$$

where  $T = T(t)$ . Consider now steady-state conditions, in which case the storage term of Eq. (1) is zero. The temperature of the object will be  $T(\infty)$  such that

$$\dot{E}_g = \bar{h}A_s(T(\infty) - T_\infty). \quad (2)$$

Substituting for  $\dot{E}_g$  using Eq. (2) into Eq. (1), the differential equation is

$$[T(\infty) - T_\infty] - [T - T_\infty] = \frac{Mc}{\bar{h}A_s} \frac{dT}{dt} \quad \text{or} \quad \theta = -\frac{Mc}{\bar{h}A_s} \frac{d\theta}{dt} \quad (3,4)$$

with  $\theta \equiv T - T(\infty)$  and noting that  $d\theta = dT$ . Identifying  $R_t = 1/\bar{h}A_s$  and  $C_t = Mc$ , the differential equation is integrated with proper limits,

$$\frac{1}{R_t C_t} \int_0^t dt = -\int_{\theta_i}^{\theta} \frac{d\theta}{\theta} \quad \text{or} \quad \frac{\theta}{\theta_i} = \exp\left[-\frac{t}{R_t C_t}\right] \quad (5) <$$

where  $\theta_i = \theta(0) = T_i - T(\infty)$  and  $T_i$  is the initial temperature of the object.

(b) Using the information about steady-state conditions and Eq. (2), find first the thermal resistance and capacitance of the system,

$$R_t = \frac{1}{\bar{h}A_s} = \frac{T(\infty) - T_\infty}{\dot{E}_g} = \frac{(100 - 20)^\circ \text{C}}{60 \text{ W}} = 1.33 \text{ K/W} \quad C_t = Mc = 0.31 \text{ kg} \times 918 \text{ J/kg}\cdot\text{K} = 285 \text{ J/K}.$$

Using Eq. (5), the temperature of the system after 5 minutes is

$$\frac{\theta(5\text{min})}{\theta_i} = \frac{T(5\text{min}) - T(\infty)}{T_i - T(\infty)} = \frac{T(5\text{min}) - 100^\circ \text{C}}{(20 - 100)^\circ \text{C}} = \exp\left[-\frac{5 \times 60\text{s}}{1.33 \text{ K/W} \times 285 \text{ J/K}}\right] = 0.453$$

$$T(5\text{min}) = 100^\circ \text{C} + (20 - 100)^\circ \text{C} \times 0.453 = 63.8^\circ \text{C} \quad <$$

**COMMENTS:** Eq. 5.24 may be used directly for Part (b) with  $a = \bar{h}A_s/Mc$  and  $b = \dot{E}_g/Mc$ .

## PROBLEM 5.21

**KNOWN:** Initial length, density and specific heat of self-assembled molecular chains. Time constant of the molecules' vibrational response.

**FIND:** Value of the contact resistance at the metal-molecule interface.

**SCHEMATIC:**

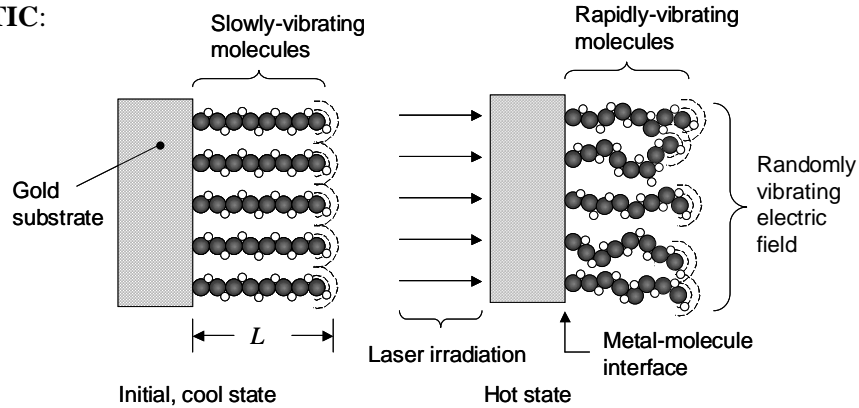

**ASSUMPTIONS:** (1) Molecules lose no thermal energy to surroundings. (2) Lumped capacitance behavior, (3) Constant properties, (4) Vibrational intensity represents temperature at the molecular scale, (5) Cylindrical molecule geometry.

**ANALYSIS:** From Equation 5.7,  $\tau_t = R_{t,c} C_t = R_{t,c}'' C_t / A_c$  where  $C_t = \rho V c_p = \rho A_c L c_p$  is the lumped thermal capacitance and  $R_{t,c}''$  is the thermal contact resistance. Combining the preceding two equations yields

$$R_{t,c}'' = \frac{\tau_t}{\rho L c_p} = \frac{5 \times 10^{-12} \text{ s}}{180 \text{ kg/m}^3 \times 2 \times 10^{-9} \text{ m} \times 3000 \text{ J/kg} \cdot \text{K}} = 4.6 \times 10^{-9} \text{ m}^2 \cdot \text{K/W} \quad <$$

**COMMENTS:** (1) The contact resistance is very small, compared to values typical of larger systems. Nonetheless, the contact resistance may be larger than the conduction resistance within the molecule or thin gold film. (2) The time response is very fast, as expected at these length scales. This suggests that computational speed using such devices will be correspondingly fast. (3) See Z. Wang, J.A. Carter, A. Lagutchev, Y.K. Koh, N.-H. Seong, D.G. Cahill, and D.D. Dlott, "Ultrafast Flash Thermal Conductance of Molecular Chains," *Science*, Vol. 317, pp. 787-790, 2007, for details.



### PROBLEM 5.22

**KNOWN:** Thickness and properties of furnace wall. Thermal resistance of film on surface of wall exposed to furnace gases. Initial wall temperature.

**FIND:** (a) Time required for surface of wall to reach a prescribed temperature, (b) Corresponding value of film surface temperature.

**SCHEMATIC:**

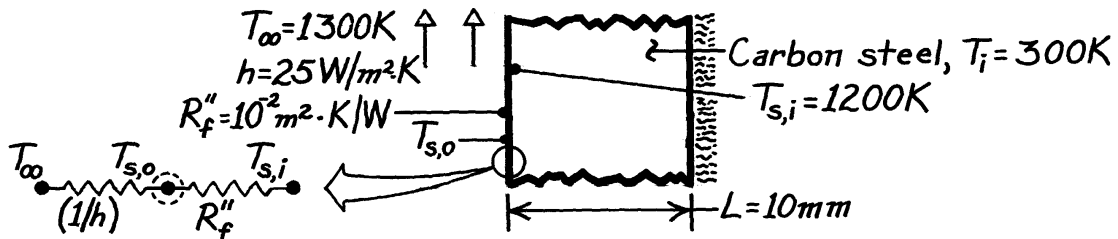

**ASSUMPTIONS:** (1) Constant properties, (2) Negligible film thermal capacitance, (3) Negligible radiation.

**PROPERTIES:** Carbon steel (given):  $\rho = 7850 \text{ kg/m}^3$ ,  $c = 430 \text{ J/kg}\cdot\text{K}$ ,  $k = 60 \text{ W/m}\cdot\text{K}$ .

**ANALYSIS:** The overall coefficient for heat transfer from the surface of the steel to the gas is

$$U = (R''_{\text{tot}})^{-1} = \left( \frac{1}{h} + R_f'' \right)^{-1} = \left( \frac{1}{25 \text{ W/m}^2 \cdot \text{K}} + 10^{-2} \text{ m}^2 \cdot \text{K/W} \right)^{-1} = 20 \text{ W/m}^2 \cdot \text{K}.$$

Hence,

$$\text{Bi} = \frac{UL}{k} = \frac{20 \text{ W/m}^2 \cdot \text{K} \times 0.01 \text{ m}}{60 \text{ W/m}\cdot\text{K}} = 0.0033$$

and the lumped capacitance method can be used.

(a) It follows that

$$\frac{T - T_{\infty}}{T_i - T_{\infty}} = \exp(-t/\tau_t) = \exp(-t/RC) = \exp(-Ut/\rho Lc)$$

$$t = -\frac{\rho Lc}{U} \ln \frac{T - T_{\infty}}{T_i - T_{\infty}} = -\frac{7850 \text{ kg/m}^3 (0.01 \text{ m}) 430 \text{ J/kg}\cdot\text{K}}{20 \text{ W/m}^2 \cdot \text{K}} \ln \frac{1200 - 1300}{300 - 1300}$$

$$t = 3886 \text{ s} = 1.08 \text{ h.} \quad <$$

(b) Performing an energy balance at the outer surface (s,o),

$$h(T_{\infty} - T_{s,o}) = (T_{s,o} - T_{s,i})/R_f''$$

$$T_{s,o} = \frac{hT_{\infty} + T_{s,i}/R_f''}{h + (1/R_f'')} = \frac{25 \text{ W/m}^2 \cdot \text{K} \times 1300 \text{ K} + 1200 \text{ K}/10^{-2} \text{ m}^2 \cdot \text{K/W}}{(25 + 100) \text{ W/m}^2 \cdot \text{K}}$$

$$T_{s,o} = 1220 \text{ K.} \quad <$$

**COMMENTS:** The film increases  $\tau_t$  by increasing  $R_t$  but not  $C_t$ .



### PROBLEM 5.23 (Cont.)

which correspond to increased process rates of 106% and 238%, respectively. Clearly, productivity can be enhanced by increasing the furnace environmental temperature, albeit at the expense of increasing energy utilization and operating costs.

If the annealing process extends from 25°C (298 K) to 600°C (873 K), numerical integration yields the following results for the prescribed furnace temperatures.

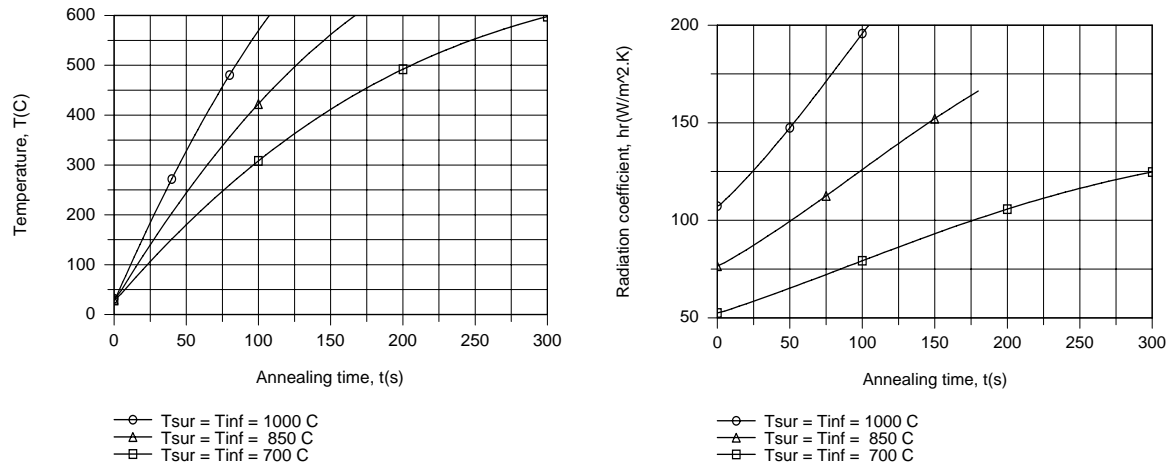

As expected, the heating rate and time, respectively, increase and decrease significantly with increasing  $T_w$ . Although the radiation heat transfer rate decreases with increasing time, the coefficient  $h_r$  increases with  $t$  as the strip temperature approaches  $T_w$ .

**COMMENTS:** To check the validity of the lumped capacitance approach, we calculate the Biot number based on a maximum cumulative coefficient of  $(h + h_r) \approx 300 \text{ W/m}^2 \cdot \text{K}$ . It follows that  $Bi = (h + h_r)(\delta/2)/k = 0.06$  and the assumption is valid.

### PROBLEM 5.24

**KNOWN:** Initial and final temperatures of a niobium sphere. Diameter and properties of the sphere. Temperature of surroundings and/or gas flow, and convection coefficient associated with the flow.

**FIND:** (a) Time required to cool the sphere exclusively by radiation, (b) Time required to cool the sphere exclusively by convection, (c) Combined effects of radiation and convection.

**SCHEMATIC:**

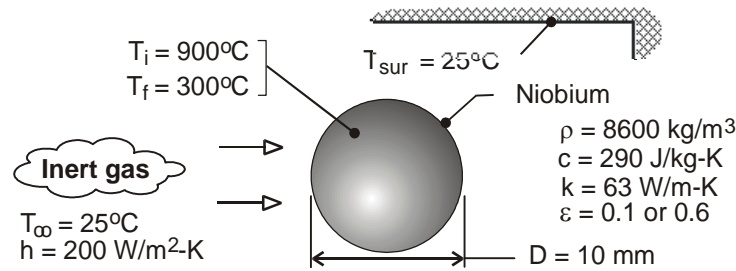

**ASSUMPTIONS:** (1) Uniform temperature at any time, (2) Negligible effect of holding mechanism on heat transfer, (3) Constant properties, (4) Radiation exchange is between a small surface and large surroundings.

**ANALYSIS:** (a) If cooling is exclusively by radiation, the required time is determined from Eq. (5.18). With  $V = \pi D^3/6$ ,  $A_{s,r} = \pi D^2$ , and  $\varepsilon = 0.1$ ,

$$t = \frac{8600 \text{ kg/m}^3 (290 \text{ J/kg} \cdot \text{K}) 0.01 \text{ m}}{24(0.1) 5.67 \times 10^{-8} \text{ W/m}^2 \cdot \text{K}^4 (298 \text{ K})^3} \left\{ \ln \left| \frac{298 + 573}{298 - 573} \right| - \ln \left| \frac{298 + 1173}{298 - 1173} \right| \right. \\ \left. + 2 \left[ \tan^{-1} \left( \frac{573}{298} \right) - \tan^{-1} \left( \frac{1173}{298} \right) \right] \right\}$$

$$t = 6926 \text{ s} \{ 1.153 - 0.519 + 2(1.091 - 1.322) \} = 1190 \text{ s} \quad (\varepsilon = 0.1) \quad <$$

If  $\varepsilon = 0.6$ , cooling is six times faster, in which case,

$$t = 199 \text{ s} \quad (\varepsilon = 0.6) \quad <$$

(b) If cooling is exclusively by convection, Eq. (5.5) yields

$$t = \frac{\rho c D}{6h} \ln \left( \frac{T_i - T_\infty}{T_f - T_\infty} \right) = \frac{8600 \text{ kg/m}^3 (290 \text{ J/kg} \cdot \text{K}) 0.010 \text{ m}}{1200 \text{ W/m}^2 \cdot \text{K}} \ln \left( \frac{875}{275} \right)$$

$$t = 24.1 \text{ s} \quad <$$

(c) With both radiation and convection, the temperature history may be obtained from Eq. (5.15).

$$\rho \left( \pi D^3 / 6 \right) c \frac{dT}{dt} = -\pi D^2 \left[ h(T - T_\infty) + \varepsilon \sigma \left( T^4 - T_{\text{sur}}^4 \right) \right]$$

Integrating numerically from  $T_i = 1173 \text{ K}$  at  $t = 0$  to  $T = 573 \text{ K}$ , we obtain

$$t = 21.0 \text{ s} \quad <$$

Continued ...

### PROBLEM 5.24 (Cont.)

Cooling times corresponding to representative changes in  $\epsilon$  and  $h$  are tabulated as follows

$h(\text{W}/\text{m}^2 \cdot \text{K})$		200	200	20	500
$\epsilon$		0.6	1.0	0.6	0.6
$t(\text{s})$		21.0	19.4	102.8	9.1

For values of  $h$  representative of forced convection, the influence of radiation is secondary, even for a maximum possible emissivity of 1.0. Hence, to accelerate cooling, it is necessary to increase  $h$ . However, if cooling is by natural convection, radiation is significant. For a representative natural convection coefficient of  $h = 20 \text{ W}/\text{m}^2 \cdot \text{K}$ , the radiation flux exceeds the convection flux at the surface of the sphere during early to intermediate stages of the transient.

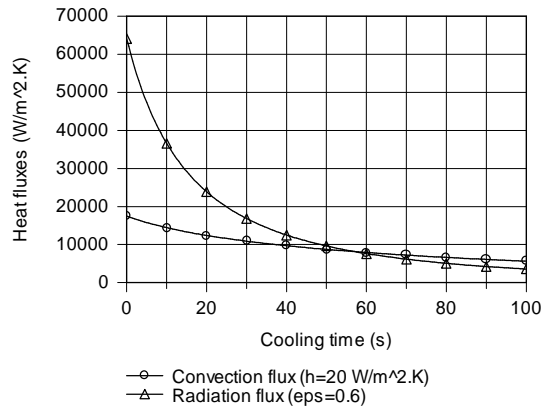

**COMMENTS:** (1) Even for  $h$  as large as  $500 \text{ W}/\text{m}^2 \cdot \text{K}$ ,  $\text{Bi} = h(D/6)/k = 500 \text{ W}/\text{m}^2 \cdot \text{K} (0.01\text{m}/6)/63 \text{ W}/\text{m} \cdot \text{K} = 0.013 < 0.1$  and the lumped capacitance model is appropriate. (2) The largest value of  $h_r$  corresponds to  $T_i = 1173 \text{ K}$ , and for  $\epsilon = 0.6$  Eq. (1.9) yields  $h_r = 0.6 \times 5.67 \times 10^{-8} \text{ W}/\text{m}^2 \cdot \text{K}^4 (1173 + 298)\text{K} (1173^2 + 298^2)\text{K}^2 = 73.3 \text{ W}/\text{m}^2 \cdot \text{K}$ .

## PROBLEM 5.25

**KNOWN:** Diameter and thermophysical properties of alumina particles. Convection conditions associated with a two-step heating process.

**FIND:** (a) Time-in-flight ( $t_{i-f}$ ) required for complete melting, (b) Validity of assuming negligible radiation.

**SCHEMATIC:**

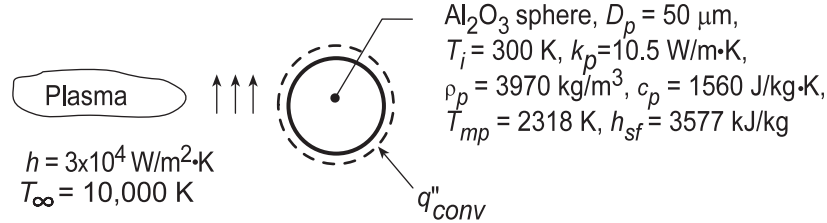

**ASSUMPTIONS:** (1) Particle behaves as a lumped capacitance, (2) Negligible radiation, (3) Constant properties.

**ANALYSIS:** (a) The two-step process involves (i) the time  $t_1$  to heat the particle to its melting point and (ii) the time  $t_2$  required to achieve complete melting. Hence,  $t_{i-f} = t_1 + t_2$ , where from Eq. (5.5),

$$t_1 = \frac{\rho_p V c_p}{h A_s} \ln \frac{\theta_i}{\theta} = \frac{\rho_p D_p c_p}{6h} \ln \frac{T_i - T_\infty}{T_{mp} - T_\infty}$$

$$t_1 = \frac{3970 \text{ kg/m}^3 (50 \times 10^{-6} \text{ m}) 1560 \text{ J/kg} \cdot \text{K}}{6 (30,000 \text{ W/m}^2 \cdot \text{K})} \ln \frac{(300 - 10,000)}{(2318 - 10,000)} = 4 \times 10^{-4} \text{ s}$$

Performing an energy balance for the second step, we obtain

$$\int_{t_1}^{t_1+t_2} q_{conv} dt = \Delta E_{st}$$

where  $q_{conv} = h A_s (T_\infty - T_{mp})$  and  $\Delta E_{st} = \rho_p V h_{sf}$ . Hence,

$$t_2 = \frac{\rho_p D_p}{6h} \frac{h_{sf}}{(T_\infty - T_{mp})} = \frac{3970 \text{ kg/m}^3 (50 \times 10^{-6} \text{ m})}{6 (30,000 \text{ W/m}^2 \cdot \text{K})} \times \frac{3.577 \times 10^6 \text{ J/kg}}{(10,000 - 2318) \text{ K}} = 5 \times 10^{-4} \text{ s}$$

Hence  $t_{i-f} = 9 \times 10^{-4} \text{ s} \approx 1 \text{ ms}$  <

(b) Contrasting the smallest value of the convection heat flux,  $q''_{conv,min} = h(T_\infty - T_{mp}) = 2.3 \times 10^8 \text{ W/m}^2$  to the largest radiation flux,  $q''_{rad,max} = \varepsilon \sigma (T_{mp}^4 - T_{sur}^4) = 6.7 \times 10^5 \text{ W/m}^2$ , with  $\varepsilon = 0.41$  from Table A.11 for aluminum oxide at 1500 K, and  $T_{sur} = 300 \text{ K}$  we conclude that radiation is, in fact, negligible.

**COMMENTS:** (1) Since  $Bi = (hr_p/3)/k \approx 0.02$ , the lumped capacitance assumption is good. (2) In an actual application, the droplet should impact the substrate in a superheated condition ( $T > T_{mp}$ ), which would require a slightly larger  $t_{i-f}$ .

## PROBLEM 5.26

**KNOWN:** Diameter and initial temperature of nanostructured ceramic particle. Plasma temperature and convection heat transfer coefficient. Properties and velocity of particles.

**FIND:** (a) Time-in-flight corresponding to 30% of the particle mass being melted. (b) Time-in-flight corresponding to the particle being 70% melted. (c) Standoff distances between the nozzle and the substrate associated with parts (a) and (b).

**SCHEMATIC:**

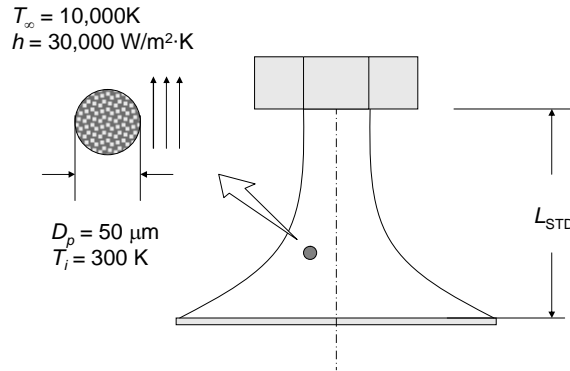

**ASSUMPTIONS:** (1) Constant properties. (2) Negligible radiation.

**PROPERTIES:** Given;  $k = 5 \text{ W/m}\cdot\text{K}$ ,  $\rho = 3800 \text{ kg/m}^3$ ,  $c_p = 1560 \text{ J/kg}\cdot\text{K}$ ,  $h_{sf} = 3577 \text{ kJ/kg}$ ,  $T_{mp} = 2318 \text{ K}$ .

**ANALYSIS:** (a) To determine whether the lumped capacitance assumption is appropriate, the Biot number is calculated as

$$Bi = \frac{h(r_o/3)}{k} = \frac{hD}{6k} = \frac{30,000 \text{ W/m}^2 \cdot \text{K} \times 50 \times 10^{-6} \text{ m}}{6 \times 5 \text{ W/m}\cdot\text{K}} = 0.05$$

Since  $Bi < 0.1$ , the lumped capacitance approximation is valid. The particle heating process can be divided into two stages.

Stage 1: Heating to the melting temperature. The time-of-flight for the first stage is found from Equation 5.5.

$$\begin{aligned} t_1 &= \frac{\rho V c}{h A_s} \ln \frac{\theta_i}{\theta} = \frac{\rho D c}{6h} \ln \frac{T_i - T_\infty}{T_{mp} - T_\infty} \\ &= \frac{3800 \text{ kg/m}^3 \times 50 \times 10^{-6} \text{ m} \times 1560 \text{ J/kg}\cdot\text{K}}{6 \times 30,000 \text{ W/m}^2 \cdot \text{K}} \ln \frac{300 \text{ K} - 10,000 \text{ K}}{2318 \text{ K} - 10,000 \text{ K}} \\ &= 0.00038 \text{ s} \end{aligned}$$

Stage 2: Melting to 30% liquid. The second stage involves heat transfer to the particle which is isothermal at its melting point temperature. Hence

Continued...

**PROBLEM 5.26 (Cont.)**

$$t_{2,0.3} = \frac{\Delta E}{q} = \frac{0.3\rho Vh_{sf}}{hA_s(T_\infty - T_{mp})} = \frac{0.05\rho Dh_{sf}}{h(T_\infty - T_{mp})}$$

$$= \frac{0.05 \times 3800 \text{ kg/m}^3 \times 50 \times 10^{-6} \text{ m} \times 3577 \times 10^3 \text{ J/kg}}{30,000 \text{ W/m}^2 \cdot \text{K} \times (10,000 - 2318) \text{ K}} = 0.00015 \text{ s}$$

Therefore the required time-of-flight is  $t_{\text{tot},0.3} = t_1 + t_{2,0.3} = 0.00038 \text{ s} + 0.00015 \text{ s} = 0.00053 \text{ s}$  <

(b) The calculation for the second stage may be repeated for 70% liquid, yielding  $t_{2,0.7} = 0.00034 \text{ s}$ .

Therefore the required time-of-flight is  $t_{\text{tot},0.7} = t_1 + t_{2,0.7} = 0.00038 \text{ s} + 0.000341 \text{ s} = 0.00072 \text{ s}$  <

(c) The required standoff distances are

$$L_{\text{STD},0.3} = Vt_{\text{tot},0.3} = 35 \text{ m/s} \times 0.00053 \text{ s} = 0.019 \text{ m} = 19 \text{ mm} \quad <$$

$$L_{\text{STD},0.7} = Vt_{\text{tot},0.7} = 35 \text{ m/s} \times 0.00072 \text{ s} = 0.025 \text{ m} = 25 \text{ mm}$$

**COMMENTS:** (1) Assuming the particles to have an emissivity of  $\epsilon_p = 0.4$  and radiation is exchanged with surroundings at an assumed temperature of  $T_{\text{sur}} = 300 \text{ K}$ , the radiation heat transfer coefficient may be found from Equation 1.9 as

$$h_r = \epsilon_p \sigma (T_{\text{mp}} + T_{\text{sur}})(T_{\text{mp}}^2 + T_{\text{sur}}^2) = 0.4 \times 5.67 \times 10^{-8} \frac{\text{W}}{\text{m}^2 \cdot \text{K}^4} (2318 + 300) \text{ K} \times (2318^2 + 300^2) = 320 \text{ W/m}^2 \cdot \text{K}.$$

Hence  $h_r \ll h_{\text{conv}}$  and radiation heat transfer is negligible. (2) To deliver a partially-molten droplet to the substrate, standoff distances on the order of 20 mm need to be maintained. This is a reasonable requirement. (3) See I. Ahmed and T.L. Bergman, "Simulation of Thermal Plasma Spraying of Partially Molten Ceramics: Effect of Carrier Gas on Particle Deposition and Phase Change Phenomena," *ASME Journal of Heat Transfer*, vol. 123, pp. 188-196, 2001, for more information.



### PROBLEM 5.27

**KNOWN:** Dimensions and operating conditions of an integrated circuit.

**FIND:** Steady-state temperature and time to come within 1°C of steady-state.

**SCHEMATIC:**

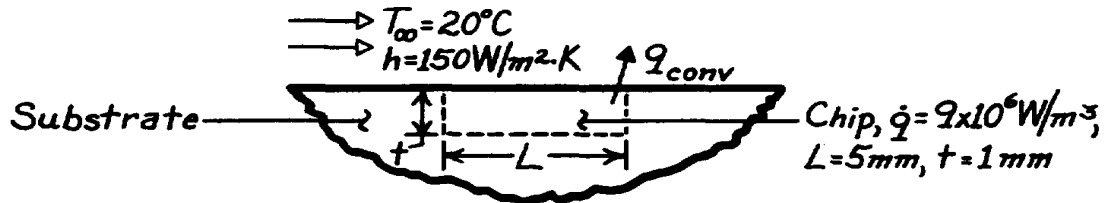

**ASSUMPTIONS:** (1) Constant properties, (2) Negligible heat transfer from chip to substrate.

**PROPERTIES:** Chip material (given):  $\rho = 2000 \text{ kg/m}^3$ ,  $c = 700 \text{ J/kg}\cdot\text{K}$ .

**ANALYSIS:** At steady-state, conservation of energy yields

$$\begin{aligned} -\dot{E}_{\text{out}} + \dot{E}_{\text{g}} &= 0 \\ -h(L^2)(T_f - T_\infty) + \dot{q}(L^2 \cdot t) &= 0 \\ T_f &= T_\infty + \frac{\dot{q}t}{h} \end{aligned}$$

$$T_f = 20^\circ\text{C} + \frac{9 \times 10^6 \text{ W/m}^3 \times 0.001 \text{ m}}{150 \text{ W/m}^2 \cdot \text{K}} = 80^\circ\text{C} \quad <$$

From the general lumped capacitance analysis, Equation 5.15 reduces to

$$\rho(L^2 \cdot t)c \frac{dT}{dt} = \dot{q}(L^2 \cdot t) - h(T - T_\infty)L^2.$$

With

$$\begin{aligned} a &\equiv \frac{h}{\rho tc} = \frac{150 \text{ W/m}^2 \cdot \text{K}}{(2000 \text{ kg/m}^3)(0.001 \text{ m})(700 \text{ J/kg}\cdot\text{K})} = 0.107 \text{ s}^{-1} \\ b &\equiv \frac{\dot{q}}{\rho c} = \frac{9 \times 10^6 \text{ W/m}^3}{(2000 \text{ kg/m}^3)(700 \text{ J/kg}\cdot\text{K})} = 6.429 \text{ K/s}. \end{aligned}$$

From Equation 5.24,

$$\exp(-at) = \frac{T - T_\infty - b/a}{T_i - T_\infty - b/a} = \frac{(79 - 20 - 60) \text{ K}}{(20 - 20 - 60) \text{ K}} = 0.01667$$

$$t = -\frac{\ln(0.01667)}{0.107 \text{ s}^{-1}} = 38.3 \text{ s} \quad <$$

**COMMENTS:** Due to additional heat transfer from the chip to the substrate, the actual values of  $T_f$  and  $t$  are less than those which have been computed.

### PROBLEM 5.28

**KNOWN:** Dimensions and operating conditions of an integrated circuit.

**FIND:** Steady-state temperature and time to come within 1°C of steady-state.

**SCHEMATIC:**

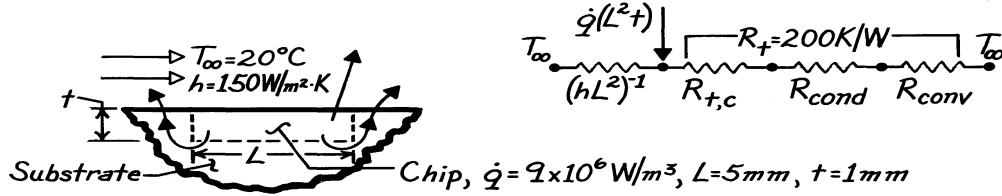

**ASSUMPTIONS:** (1) Constant properties.

**PROPERTIES:** Chip material (given):  $\rho = 2000 \text{ kg/m}^3$ ,  $c_p = 700 \text{ J/kg}\cdot\text{K}$ .

**ANALYSIS:** The direct and indirect paths for heat transfer from the chip to the coolant are in parallel, and the equivalent resistance is

$$R_{\text{equiv}} = \left[ hL^2 + R_t^{-1} \right]^{-1} = \left[ \left( 3.75 \times 10^{-3} + 5 \times 10^{-3} \right) \text{ W/K} \right]^{-1} = 114.3 \text{ K/W}.$$

The corresponding overall heat transfer coefficient is

$$U = \frac{\left( R_{\text{equiv}} \right)^{-1}}{L^2} = \frac{0.00875 \text{ W/K}}{\left( 0.005 \text{ m} \right)^2} = 350 \text{ W/m}^2 \cdot \text{K}.$$

To obtain the steady-state temperature, apply conservation of energy to a control surface about the chip.

$$-\dot{E}_{\text{out}} + \dot{E}_{\text{g}} = 0 \quad -UL^2(T_f - T_{\infty}) + \dot{q}(L^2 \cdot t) = 0$$

$$T_f = T_{\infty} + \frac{\dot{q}t}{U} = 20^\circ\text{C} + \frac{9 \times 10^6 \text{ W/m}^3 \times 0.001 \text{ m}}{350 \text{ W/m}^2 \cdot \text{K}} = 45.7^\circ\text{C}. \quad <$$

From the general lumped capacitance analysis, Equation 5.15 yields

$$\rho(L^2t)c \frac{dT}{dt} = \dot{q}(L^2t) - U(T - T_{\infty})L^2.$$

With

$$a \equiv \frac{U}{\rho tc} = \frac{350 \text{ W/m}^2 \cdot \text{K}}{\left( 2000 \text{ kg/m}^3 \right) \left( 0.001 \text{ m} \right) \left( 700 \text{ J/kg} \cdot \text{K} \right)} = 0.250 \text{ s}^{-1}$$

$$b = \frac{\dot{q}}{\rho c} = \frac{9 \times 10^6 \text{ W/m}^3}{\left( 2000 \text{ kg/m}^3 \right) \left( 700 \text{ J/kg} \cdot \text{K} \right)} = 6.429 \text{ K/s}$$

Equation 5.24 yields

$$\exp(-at) = \frac{T - T_{\infty} - b/a}{T_i - T_{\infty} - b/a} = \frac{(44.7 - 20 - 25.7) \text{ K}}{(20 - 20 - 25.7) \text{ K}} = 0.0389$$

$$t = -\ln(0.0389) / 0.250 \text{ s}^{-1} = 13.0 \text{ s}. \quad <$$

**COMMENTS:** Heat transfer through the substrate is comparable to that associated with direct convection to the coolant.

### PROBLEM 5.29

**KNOWN:** Diameter, resistance and current flow for a wire. Convection coefficient and temperature of surrounding oil.

**FIND:** Steady-state temperature of the wire. Time for the wire temperature to come within 1°C of its steady-state value.

**SCHEMATIC:**

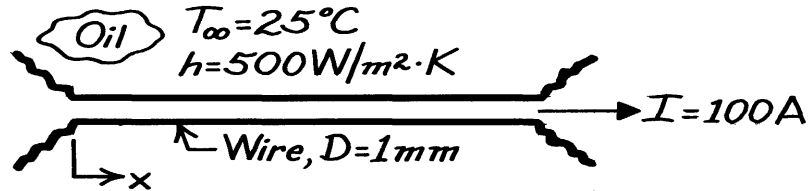

**ASSUMPTIONS:** (1) Constant properties, (2) Wire temperature is independent of  $x$ .

**PROPERTIES:** Wire (given):  $\rho = 8000 \text{ kg/m}^3$ ,  $c_p = 500 \text{ J/kg}\cdot\text{K}$ ,  $k = 20 \text{ W/m}\cdot\text{K}$ ,  $R'_e = 0.01 \Omega/\text{m}$ .

**ANALYSIS:** Since

$$Bi = \frac{h(r_o/2)}{k} = \frac{500 \text{ W/m}^2 \cdot \text{K} (2.5 \times 10^{-4} \text{ m})}{20 \text{ W/m}\cdot\text{K}} = 0.006 < 0.1$$

the lumped capacitance method can be used. The problem has been analyzed in Example 1.4, and without radiation the steady-state temperature is given by

$$\pi Dh(T - T_\infty) = I^2 R'_e.$$

Hence

$$T = T_\infty + \frac{I^2 R'_e}{\pi Dh} = 25^\circ\text{C} + \frac{(100\text{A})^2 0.01\Omega/\text{m}}{\pi (0.001 \text{ m}) 500 \text{ W/m}^2 \cdot \text{K}} = 88.7^\circ\text{C}. \quad <$$

With no radiation, the transient thermal response of the wire is governed by the expression (Example 1.4)

$$\frac{dT}{dt} = \frac{I^2 R'_e}{\rho c_p (\pi D^2 / 4)} - \frac{4h}{\rho c_p D} (T - T_\infty).$$

With  $T = T_1 = 25^\circ\text{C}$  at  $t = 0$ , the solution is

$$\frac{T - T_\infty - (I^2 R'_e / \pi Dh)}{T_1 - T_\infty - (I^2 R'_e / \pi Dh)} = \exp\left(-\frac{4h}{\rho c_p D} t\right).$$

Substituting numerical values, find

$$\frac{87.7 - 25 - 63.7}{25 - 25 - 63.7} = \exp\left(-\frac{4 \times 500 \text{ W/m}^2 \cdot \text{K}}{8000 \text{ kg/m}^3 \times 500 \text{ J/kg}\cdot\text{K} \times 0.001 \text{ m}} t\right)$$

$$t = 8.31\text{s}. \quad <$$

**COMMENTS:** The time to reach steady state increases with increasing  $\rho$ ,  $c_p$  and  $D$  and with decreasing  $h$ .

### PROBLEM 5.30

**KNOWN:** Electrical heater attached to backside of plate while front is exposed to a convection process ( $T_\infty, h$ ); initially plate is at uniform temperature  $T_\infty$  before heater power is switched on.

**FIND:** (a) Expression for temperature of plate as a function of time assuming plate is spacewise isothermal, (b) Approximate time to reach steady-state and  $T(\infty)$  for prescribed  $T_\infty, h$  and  $q_o''$  when wall material is pure copper, (c) Effect of  $h$  on thermal response.

**SCHEMATIC:**

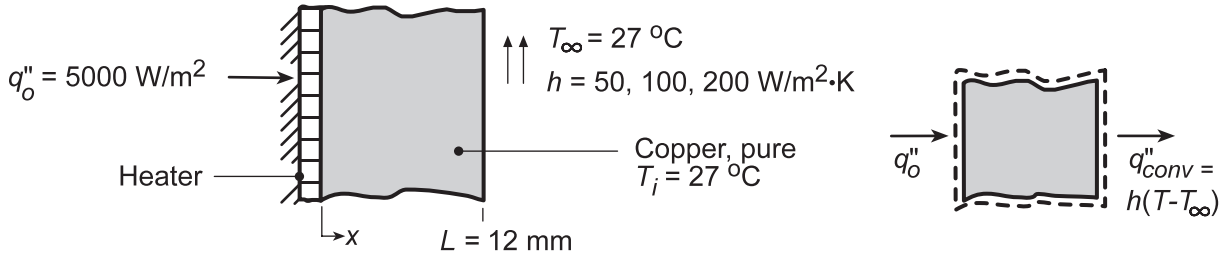

**ASSUMPTIONS:** (1) Plate behaves as lumped capacitance, (2) Negligible loss out backside of heater, (3) Negligible radiation, (4) Constant properties.

**PROPERTIES:** Table A-1, Copper, pure (350 K):  $k = 397 \text{ W/m}\cdot\text{K}$ ,  $c_p = 385 \text{ J/kg}\cdot\text{K}$ ,  $\rho = 8933 \text{ kg/m}^3$ .

**ANALYSIS:** (a) Following the analysis of Section 5.3, the energy conservation requirement for the system is  $\dot{E}_{in} - \dot{E}_{out} = \dot{E}_{st}$  or  $q_o'' - h(T - T_\infty) = \rho L c_p dT/dt$ . Rearranging, and with  $R_t'' = 1/h$  and  $C_t'' = \rho L c_p$ ,

$$T - T_\infty - q_o''/h = -R_t'' \cdot C_t'' dT/dt \quad (1)$$

Defining  $\theta(t) \equiv T - T_\infty - q_o''/h$  with  $d\theta = dT$ , the differential equation is

$$\theta = -R_t'' C_t'' \frac{d\theta}{dt} \quad (2)$$

Separating variables and integrating,

$$\int_{\theta_i}^{\theta} \frac{d\theta}{\theta} = - \int_0^t \frac{dt}{R_t'' C_t''}$$

it follows that

$$\frac{\theta}{\theta_i} = \exp\left(-\frac{t}{R_t'' C_t''}\right) \quad (3) <$$

where  $\theta_i = \theta(0) = T_i - T_\infty - (q_o''/h)$  (4)

(b) For  $h = 50 \text{ W/m}^2 \cdot \text{K}$ , the steady-state temperature can be determined from Eq. (3) with  $t \rightarrow \infty$ ; that is,

$$\theta(\infty) = 0 = T(\infty) - T_\infty - q_o''/h \quad \text{or} \quad T(\infty) = T_\infty + q_o''/h,$$

giving  $T(\infty) = 27^\circ\text{C} + 5000 \text{ W/m}^2 / 50 \text{ W/m}^2 \cdot \text{K} = 127^\circ\text{C}$ . To estimate the time to reach steady-state, first determine the thermal time constant of the system,

$$\tau_t = R_t'' C_t'' = \left(\frac{1}{h}\right) (\rho c_p L) = \left(\frac{1}{50 \text{ W/m}^2 \cdot \text{K}}\right) (8933 \text{ kg/m}^3 \times 385 \text{ J/kg} \cdot \text{K} \times 12 \times 10^{-3} \text{ m}) = 825 \text{ s}$$

Continued...

### PROBLEM 5.30 (Cont.)

When  $t = 3\tau_t = 3 \times 825 \text{ s} = 2475 \text{ s}$ , Eqs. (3) and (4) yield

$$\theta(3\tau_t) = T(3\tau_t) - 27^\circ\text{C} - \frac{5000 \text{ W/m}^2}{50 \text{ W/m}^2 \cdot \text{K}} = e^{-3} \left[ 27^\circ\text{C} - 27^\circ\text{C} - \frac{5000 \text{ W/m}^2}{50 \text{ W/m}^2 \cdot \text{K}} \right]$$

$$T(3\tau_t) = 122^\circ\text{C}$$

<

(c) As shown by the following graphical results, which were generated using the IHT *Lumped Capacitance Model*, the steady-state temperature and the time to reach steady-state both decrease with increasing  $h$ .

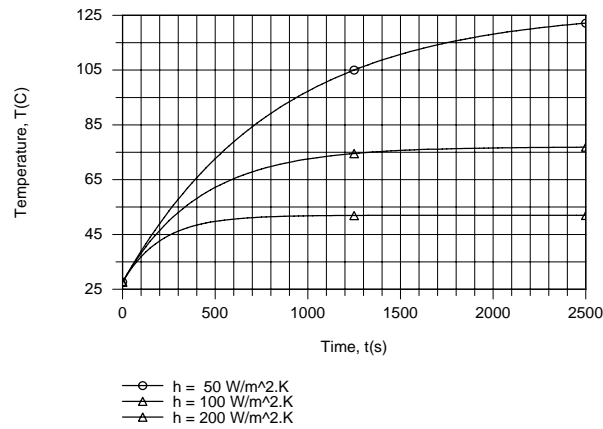

**COMMENTS:** Note that, even for  $h = 200 \text{ W/m}^2 \cdot \text{K}$ ,  $Bi = hL/k \ll 0.1$  and assumption (1) is reasonable.

### PROBLEM 5.31

**KNOWN:** Initial dimensions and temperature of SMA rod, ambient temperature and convection heat transfer coefficient. Properties of SMA.

**FIND:** Thermal response of the rod assuming constant and variable specific heats, time for rod temperature to experience 95% of the maximum temperature change.

**SCHEMATIC:**

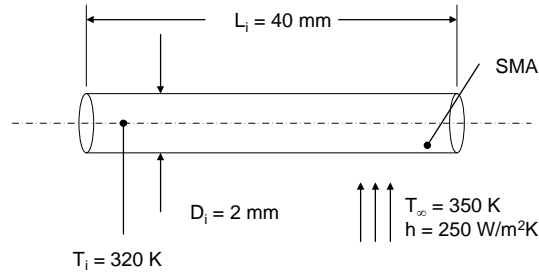

**ASSUMPTIONS:** (1) Lumped capacitance behavior, (2) Effect of change in density and dimensions is negligible, (3) Negligible radiation.

**PROPERTIES:** Given:  $c = 500 \frac{\text{J}}{\text{kg} \cdot \text{K}} + 3630 \text{ J/kg} \cdot \text{K} \times e^{(-0.808\text{K}^{-1} \times |T-336\text{K}|)}$ ,  $\rho = 8900 \text{ kg/m}^3$ ,  $k = 23 \text{ W/m} \cdot \text{K}$ .

**ANALYSIS:** The Biot number associated with the rod (evaluating dimensions at the initial temperature) is  $Bi = h(D_i/4)/k = 250 \text{ W/m}^2 \cdot \text{K} \times 2 \times 10^{-3} \text{ m}/4/23 \text{ W/m} \cdot \text{K} = 0.005 \ll 0.1$ . Therefore, the lumped capacitance approach is valid. Neglecting the change in the surface area as the rod is heated,

$$\frac{dT}{dt} = -\frac{hA_s(T - T_\infty)}{\rho Vc} = -\frac{4h}{\rho D_i c} (T - T_\infty)$$

$$= -\frac{4 \times 250 \text{ W/m}^2 \cdot \text{K} \times (T - T_\infty)}{8900 \text{ kg/m}^3 \times 0.002 \text{ m} \times \left[ 500 \frac{\text{J}}{\text{kg} \cdot \text{K}} + 3630 \text{ J/kg} \cdot \text{K} \times e^{(-0.808\text{K}^{-1} \times |T-336\text{K}|)} \right]}$$

Because of the absolute value function, the preceding expression is most readily integrated numerically to determine  $T(t)$ . Based upon an initial temperature of  $T_i = 320 \text{ K}$ , the following results are found using the IHT code included in the Comments.

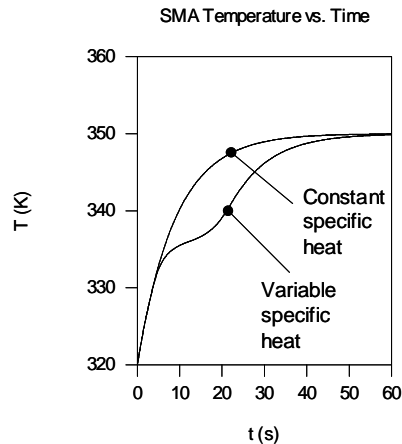

Continued...

### PROBLEM 5.31 (Cont.)

Inspection of the predicted response shows the time needed for the rod to experience 95% of its total temperature change (to  $T_{95} = T_i + 0.95 \times (T_f - T_i) = 320 \text{ K} + 0.95 \times (350 - 320) \text{ K} = 348.5 \text{ K}$ ) is 38.2 s and 27.1 s for the variable and constant specific heat cases, respectively. <

**COMMENTS:** (1) A plot of the specific heat is shown below. The onset of large specific heat values associated with the crystalline transformation slows the thermal response, as evident in the preceding plot. (2) The IHT code is listed below.

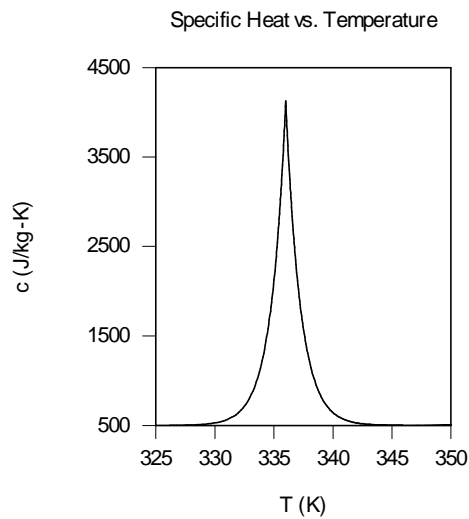

```
// Solid Properties and Geometry
rho = 8900 //kg/m^3
A= pi*D*L //m^2
D= 2/1000 //m
L = 40/1000 //m
V = L*pi*D*D/4 //m^3
cpnot = 500 //J/kgK

//Convective Conditions
Tinf = 350 //K
h = 250 //W/m^2K

//Variable Property Solution
der(Tvp,t) = h*A*(Tinf - Tvp)/rho/cpstar/V
cpstar = cpnot +( 9*10^3)*0.403*exp(-abs(0.808*(Tair-336)))

//Constant Property Solution
der(Tcp,t) = h*A*(Tinf - Tcp)/rho/cpnot/V
```

### PROBLEM 5.32

**KNOWN:** Spherical coal pellet at 25°C is heated by radiation while flowing through a furnace maintained at 1000°C.

**FIND:** Length of tube required to heat pellet to 600°C.

**SCHEMATIC:**

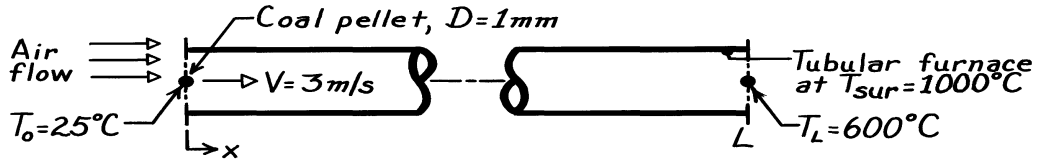

**ASSUMPTIONS:** (1) Pellet is suspended in air flow and subjected to only radiative exchange with furnace, (2) Pellet is small compared to furnace surface area, (3) Coal pellet has emissivity,  $\epsilon = 1$ .

**PROPERTIES:** Table A-3, Coal ( $\bar{T} = (600 + 25)^\circ\text{C}/2 = 585\text{K}$ , however, only 300K data available):  $\rho = 1350 \text{ kg/m}^3$ ,  $c_p = 1260 \text{ J/kg}\cdot\text{K}$ ,  $k = 0.26 \text{ W/m}\cdot\text{K}$ .

**ANALYSIS:** Considering the pellet as spatially isothermal, use the lumped capacitance method of Section 5.3 to find the time required to heat the pellet from  $T_o = 25^\circ\text{C}$  to  $T_L = 600^\circ\text{C}$ . From an energy balance on the pellet  $\dot{E}_{\text{in}} = \dot{E}_{\text{st}}$  where

$$\dot{E}_{\text{in}} = q_{\text{rad}} = \sigma A_s (T_{\text{sur}}^4 - T_s^4) \quad \dot{E}_{\text{st}} = \rho \forall c_p \frac{dT}{dt}$$

giving  $A_s \sigma (T_{\text{sur}}^4 - T_s^4) = \rho \forall c_p \frac{dT}{dt}$ .

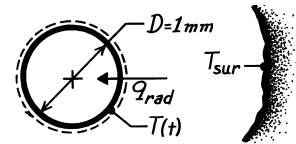

Separating variables and integrating with limits shown, the temperature-time relation becomes

$$\frac{A_s \sigma}{\rho \forall c_p} \int_0^t dt = \int_{T_o}^{T_L} \frac{dT}{T_{\text{sur}}^4 - T^4}$$

The integrals are evaluated in Eq. 5.18 giving

$$t = \frac{\rho \forall c_p}{4 A_s \sigma T_{\text{sur}}^3} \left\{ \ln \left| \frac{T_{\text{sur}} + T}{T_{\text{sur}} - T} \right| - \ln \left| \frac{T_{\text{sur}} + T_i}{T_{\text{sur}} - T_i} \right| + 2 \left[ \tan^{-1} \left[ \frac{T}{T_{\text{sur}}} \right] - \tan^{-1} \left[ \frac{T_i}{T_{\text{sur}}} \right] \right] \right\}$$

Recognizing that  $A_s = \pi D^2$  and  $\forall = \pi D^3/6$  or  $A_s/\forall = 6/D$  and substituting values,

$$t = \frac{1350 \text{ kg/m}^3 (0.001 \text{ m}) 1260 \text{ J/kg}\cdot\text{K}}{24 \times 5.67 \times 10^{-8} \text{ W/m}^2 \cdot \text{K}^4 (1273 \text{ K})^3} \left\{ \ln \frac{1273 + 873}{1273 - 873} - \ln \frac{1273 + 298}{1273 - 298} + 2 \left[ \tan^{-1} \left( \frac{873}{1273} \right) - \tan^{-1} \left( \frac{298}{1273} \right) \right] \right\} = 1.18 \text{ s}$$

Hence,  $L = V \cdot t = 3 \text{ m/s} \times 1.18 \text{ s} = 3.54 \text{ m}$ .

The validity of the lumped capacitance method requires  $Bi = h(\forall/A_s)/k < 0.1$ . Using Eq. (1.9) for  $h = h_r$  and  $\forall/A_s = D/6$ , find that when  $T = 600^\circ\text{C}$ ,  $Bi = 0.19$ ; but when  $T = 25^\circ\text{C}$ ,  $Bi = 0.10$ . At early times, when the pellet is cooler, the assumption is reasonable but becomes less appropriate as the pellet heats.



### PROBLEM 5.33

**KNOWN:** Mass and initial temperature of frozen ground beef. Temperature and convection coefficient of air. Rate of microwave power absorbed in beef.

**FIND:** (a) Time for beef to reach 0°C, (b) Time for beef to be heated from liquid at 0°C to 80°C, and (c) Explain nonuniform heating in microwave and reason for low power setting for thawing.

**SCHEMATIC:**

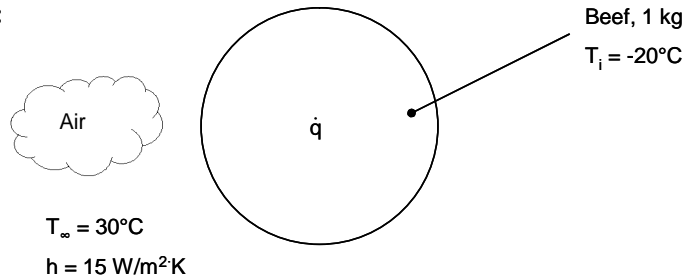

**ASSUMPTIONS:** (1) Beef is nearly isothermal, (2) Beef has properties of water (ice or liquid), (3) Radiation is negligible, (4) Constant properties (different for ice and liquid water).

**PROPERTIES:** Table A.3, Ice ( $\approx 273 \text{ K}$ ):  $\rho = 920 \text{ kg/m}^3$ ,  $c = 2040 \text{ J/kg}\cdot\text{K}$ , Table A.6, Water ( $\approx 315 \text{ K}$ ):  $c = 4179 \text{ J/kg}\cdot\text{K}$ .

**ANALYSIS:** (a) We apply conservation of energy to the beef

$$\begin{aligned} \dot{E}_{\text{in}} + \dot{E}_g &= \dot{E}_{\text{st}} \\ hA_s(T_\infty - T) + \dot{q} &= mc \frac{dT}{dt} \end{aligned} \quad (1)$$

The initial condition is  $T(0) = T_i$ . This differential equation can be solved by defining

$$\theta = T - T_\infty - \frac{\dot{q}}{hA_s}$$

Then Eq.(1) becomes  $\frac{d\theta}{dt} = -\frac{hA_s}{mc}\theta$

Separating variables and integrating,

$$\begin{aligned} \int_{\theta(0)}^{\theta(t)} \frac{d\theta}{\theta} &= -\frac{hA_s}{mc} \int_0^t dt \\ \ln \left[ \frac{\theta(t)}{\theta(0)} \right] &= -\frac{hA_s t}{mc} \\ \ln \left[ \frac{T - T_\infty - \dot{q}/hA_s}{T_i - T_\infty - \dot{q}/hA_s} \right] &= -\frac{hA_s t}{mc} \end{aligned} \quad (2)$$

The heat generation rate is given by  $\dot{q} = 0.03P = 0.03(1000 \text{ W}) = 30 \text{ W}$ . The radius of the sphere can be found from knowledge of the mass and density:

Continued...

**PROBLEM 5.33 (Cont.)**

$$m = \rho V = \rho \frac{4}{3} \pi r_o^3$$

$$r_o = \left( \frac{3 m}{4\pi \rho} \right)^{1/3} = \left( \frac{3}{4\pi} \frac{1 \text{ kg}}{920 \text{ kg/m}^3} \right)^{1/3} = 0.0638 \text{ m}$$

Thus  $A_s = 4\pi r_o^2 = 4\pi(0.0638 \text{ m})^2 = 0.0511 \text{ m}^2$

Substituting numerical values into Eq.(2), we can find the time at which the temperature reaches 0°C:

$$\ln \left[ \frac{0^\circ\text{C} - 30^\circ\text{C} - 30 \text{ W}/(15 \text{ W/m}^2 \cdot \text{K} \times 0.0511 \text{ m}^2)}{-20^\circ\text{C} - 3 \text{ } 0^\circ\text{C} - 30 \text{ W}/(15 \text{ W/m}^2 \cdot \text{K} \times 0.0511 \text{ m}^2)} \right] = - \frac{15 \text{ W/m}^2 \cdot \text{K} \times 0.0511 \text{ m}^2}{1 \text{ kg} \times 2040 \text{ J/kg} \cdot \text{K}} t$$

Thus  $t = 676 \text{ s} = 11.3 \text{ min}$  <

(b) After all the ice is converted to liquid, the absorbed power is  $\dot{q} = 0.95P = 950 \text{ W}$ . The time for the beef to reach 80°C can again be found from Eq.(2):

$$\ln \left[ \frac{80^\circ\text{C} - 30^\circ\text{C} - 950 \text{ W}/(15 \text{ W/m}^2 \cdot \text{K} \times 0.0511 \text{ m}^2)}{0^\circ\text{C} - 3 \text{ } 0^\circ\text{C} - 950 \text{ W}/(15 \text{ W/m}^2 \cdot \text{K} \times 0.0511 \text{ m}^2)} \right] = - \frac{15 \text{ W/m}^2 \cdot \text{K} \times 0.0511 \text{ m}^2}{1 \text{ kg} \times 4179 \text{ J/kg} \cdot \text{K}} t$$

Thus  $t = 355 \text{ s} = 5.9 \text{ min}$  <

(c) Microwave power is more efficiently absorbed in regions of liquid water. Therefore, if food or the microwave irradiation is not homogeneous or uniform, the power will be absorbed nonuniformly, resulting in a nonuniform temperature rise. Thawed regions will absorb more energy per unit volume than frozen regions. If food is of low thermal conductivity, there will be insufficient time for heat conduction to make the temperature more uniform. Use of low power allows more time for conduction to occur.

**COMMENTS:** (1) The time needed to turn the ice at 0°C into liquid water at 0°C was not calculated. The required energy is  $Q = mh_{fg} = 1 \text{ kg} \times 2502 \text{ kJ/kg} = 2502 \text{ kJ}$ . The required time depends on how the fraction of microwave power absorbed changes during the thawing process. The minimum possible time would be  $t_{\min} = 2502 \text{ kJ}/950 \text{ W} = 2600 \text{ s} = 44 \text{ min}$ . Therefore, the time to thaw is significant.

(2) Radiation may not be negligible. It depends on the temperature of the oven walls and the emissivity of the beef. Radiation would contribute to heating the beef.

### PROBLEM 5.34

**KNOWN:** Metal sphere, initially at a uniform temperature  $T_i$ , is suddenly removed from a furnace and suspended in a large room and subjected to a convection process ( $T_\infty, h$ ) and to radiation exchange with surroundings,  $T_{sur}$ .

**FIND:** (a) Time it takes for sphere to cool to some temperature  $T$ , neglecting radiation exchange, (b) Time it takes for sphere to cool to some temperature  $t$ , neglecting convection, (c) Procedure to obtain time required if both convection and radiation are considered, (d) Time to cool an anodized aluminum sphere to 400 K using results of Parts (a), (b) and (c).

**SCHEMATIC:**

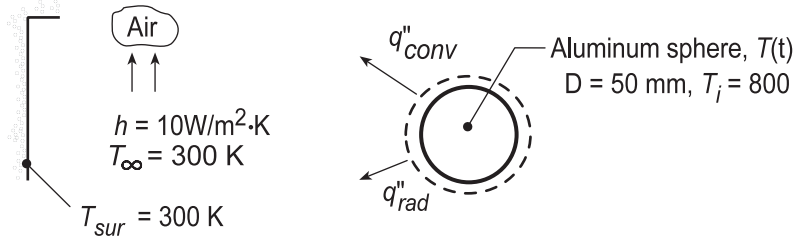

**ASSUMPTIONS:** (1) Sphere is spacewise isothermal, (2) Constant properties, (3) Constant heat transfer convection coefficient, (4) Sphere is small compared to surroundings.

**PROPERTIES:** Table A-1, Aluminum, pure ( $\bar{T} = [800 + 400] \text{ K} / 2 = 600 \text{ K}$ ):  $\rho = 2702 \text{ kg/m}^3$ ,  $c = 1033 \text{ J/kg}\cdot\text{K}$ ,  $k = 231 \text{ W/m}\cdot\text{K}$ ,  $\alpha = k/\rho c = 8.276 \times 10^{-5} \text{ m}^2/\text{s}$ ; Aluminum, anodized finish:  $\varepsilon = 0.75$ , polished surface:  $\varepsilon = 0.1$ .

**ANALYSIS:** (a) Neglecting radiation, the time to cool is predicted by Eq. 5.5,

$$t = \frac{\rho V c}{h A_s} \ln \frac{\theta_i}{\theta} = \frac{\rho D c}{6 h} \ln \frac{T_i - T_\infty}{T - T_\infty} \quad (1) <$$

where  $V/A_s = (\pi D^3/6)/(\pi D^2) = D/6$  for the sphere.

(b) Neglecting convection, the time to cool is predicted by Eq. 5.18,

$$t = \frac{\rho D c}{24 \varepsilon \sigma T_{sur}^3} \left\{ \ln \left| \frac{T_{sur} + T}{T_{sur} - T} \right| - \ln \left| \frac{T_{sur} + T_i}{T_{sur} - T_i} \right| + 2 \left[ \tan^{-1} \left( \frac{T}{T_{sur}} \right) - \tan^{-1} \left( \frac{T_i}{T_{sur}} \right) \right] \right\} \quad (2)$$

where  $V/A_{s,r} = D/6$  for the sphere.

(c) If convection and radiation exchange are considered, the energy balance requirement results in Eq. 5.15 (with  $q_s'' = \dot{E}_g = 0$ ). Hence

$$\frac{dT}{dt} = \frac{6}{\rho D c} \left[ h(T - T_\infty) + \varepsilon \sigma (T^4 - T_{sur}^4) \right] \quad (3) <$$

where  $A_{s(c,r)} = A_s = \pi D^2$  and  $V/A_{s(c,r)} = D/6$ . This relation must be solved numerically in order to evaluate the time-to-cool.

(d) For the aluminum (pure) sphere with an anodized finish and the prescribed conditions, the times to cool from  $T_i = 800 \text{ K}$  to  $T = 400 \text{ K}$  are:

Continued...

### PROBLEM 5.34 (Cont.)

Convection only, Eq. (1)

$$t = \frac{2702 \text{ kg/m}^3 \times 0.050 \text{ m} \times 1033 \text{ J/kg} \cdot \text{K}}{6 \times 10 \text{ W/m}^2 \cdot \text{K}} \ln \frac{800 - 300}{400 - 300} = 3743 \text{ s} = 1.04 \text{ h} \quad <$$

Radiation only, Eq. (2)

$$t = \frac{2702 \text{ kg/m}^3 \times 0.050 \text{ m} \times 1033 \text{ J/kg} \cdot \text{K}}{24 \times 0.75 \times 5.67 \times 10^{-8} \text{ W/m}^2 \cdot \text{K}^4 \times (300 \text{ K})^3} \cdot \left\{ \left( \ln \frac{400 + 300}{400 - 300} - \ln \frac{800 + 300}{800 - 300} \right) + 2 \left[ \tan^{-1} \frac{400}{300} - \tan^{-1} \frac{800}{300} \right] \right\}$$

$$t = 5.065 \times 10^3 \{ 1.946 - 0.789 + 2(0.927 - 1.212) \} = 2973 \text{ s} = 0.826 \text{ h} \quad <$$

Radiation and convection, Eq. (3)

Using the IHT Lumped Capacitance Model, numerical integration yields

$$t \approx 1600 \text{ s} = 0.444 \text{ h}$$

In this case, heat loss by radiation exerts the stronger influence, although the effects of convection are by no means negligible. However, if the surface is polished ( $\epsilon = 0.1$ ), convection clearly dominates. For each surface finish and the three cases, the temperature histories are as follows.

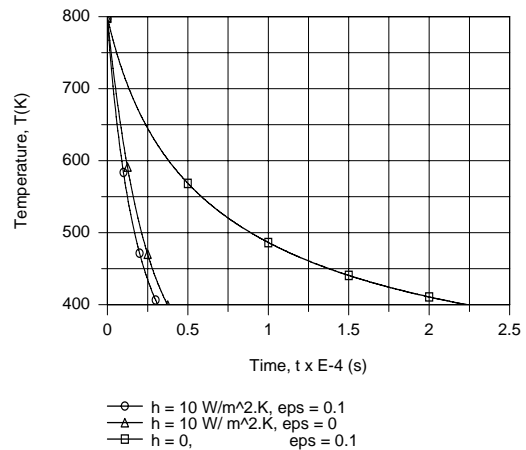
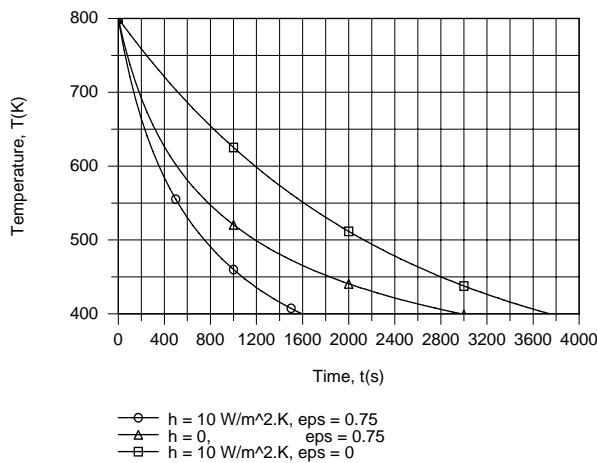

**COMMENTS:** 1. A summary of the analyses shows the relative importance of the various modes of heat loss:

Active Modes	Time required to cool to 400 K (h)	
	$\epsilon = 0.75$	$\epsilon = 0.1$
Convection only	1.040	1.040
Radiation only	0.827	6.194
Both modes	0.444	0.889

2. Note that the spacewise isothermal assumption is justified since  $Be \ll 0.1$ . For the convection-only process,

$$Bi = h(r_o/3)/k = 10 \text{ W/m}^2 \cdot \text{K} (0.025 \text{ m}/3) / 231 \text{ W/m} \cdot \text{K} = 3.6 \times 10^{-4}$$

### PROBLEM 5.35

**KNOWN:** Thickness and initial temperatures of two layers of copper and aluminum. Contact resistance at the interface between the layers, applied heat flux, and convective conditions on the upper surface of the top layer.

**FIND:** (a) Times at which the copper (bottom) and aluminum (top) reach a temperature of  $T_f = 90^\circ\text{C}$ .  
 (b) Times at which the copper (top) and aluminum (bottom) reach a temperature of  $T_f = 90^\circ\text{C}$ .

**SCHEMATIC:**

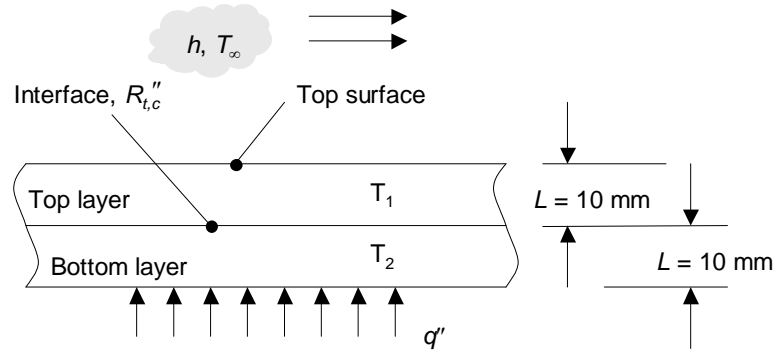

**ASSUMPTIONS:** (1) Lumped capacitance behavior, (2) Constant properties, (3) Negligible radiation.

**PROPERTIES:** Table A.1; copper ( $T = 300 \text{ K}$ ):  $\rho_A = 8933 \text{ kg/m}^3$ ,  $c_A = 385 \text{ J/kg}\cdot\text{K}$ ,  $k_A = 401 \text{ W/m}\cdot\text{K}$ ;  
 aluminum ( $T = 300 \text{ K}$ ):  $\rho_B = 2702 \text{ kg/m}^3$ ,  $c_B = 903 \text{ J/kg}\cdot\text{K}$ ,  $k_B = 237 \text{ W/m}\cdot\text{K}$ .

**ANALYSIS:** (a) For copper on the bottom, a modified form of Eq. 5.15 may be applied to both materials, resulting in

$$\text{Copper: } q_s'' - \frac{1}{R_{t,c}}(T_A - T_B) = \rho_A c_A L_A \frac{dT_A}{dt} \quad (1)$$

$$\text{Aluminum: } \frac{1}{R_{t,c}}(T_A - T_B) - h(T_B - T_\infty) = \rho_B c_B L_B \frac{dT_B}{dt} \quad (2)$$

Equations 1 and 2 are coupled differential equations with the initial conditions  $T_{i,A} = T_{i,B} = 25^\circ\text{C}$ .

Hence, a numerical solution is required, yielding  $t_{f,A} = 34.4 \text{ s}$  and  $t_{f,B} = 44.6 \text{ s}$ . <

(b) For copper on the top, modified Eq. 5.15 is written as

$$\text{Copper: } \frac{1}{R_{t,c}}(T_B - T_A) - h(T_A - T_\infty) = \rho_A c_A L_A \frac{dT_A}{dt}$$

$$\text{Aluminum: } q_s'' - \frac{1}{R_{t,c}}(T_B - T_A) = \rho_B c_B L_B \frac{dT_B}{dt}$$

The numerical solution yields  $t_{f,A} = 44.6 \text{ s}$  and  $t_{f,B} = 30.4 \text{ s}$ . <

Continued...

### PROBLEM 5.35 (Cont.)

**COMMENTS:** (1) For the aluminum on the top, the Biot number associated with the aluminum is  $Bi_B = hL_B/k_B = (40 \text{ W/m}^2\cdot\text{K} \times 10 \times 10^{-3} \text{ m})/237 \text{ W/m}\cdot\text{K} = 0.0017$ . The lumped capacitance approach is valid for the aluminum. For the copper, the contact resistance and the conduction resistance through the top aluminum layer pose thermal resistances in series with the convective resistance. In addition, the thermal conductivity of copper is greater than that of the aluminum, so lumped capacitance behavior is also expected for the copper. For the copper on top, the Biot number for the copper is  $Bi_A = 0.0010$ . Lumped capacitance behavior will also exist for this configuration. (2) The thermal responses for the two cases are shown below. Can you explain the differences?

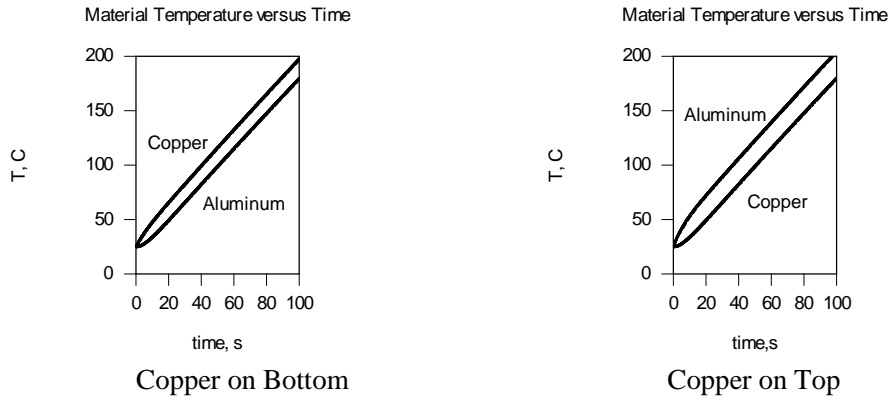

(3) At  $t = 44.6 \text{ s}$ , the temperature of the copper in part (a) is  $T_A(t = 44.6\text{s}) = 107.1^\circ\text{C}$ . At  $t = 44.6 \text{ s}$ , the temperature of the bottom aluminum in part (b) is  $T_B = 113.9^\circ\text{C}$ . Hence, the increase in thermal energy of both materials per unit area during the first 44.6 s of heating for part (a) is  $\Delta E_{st}'' = L_A c_A [T_A(t = 44.6 \text{ s}) - T_i] + L_B c_B [T_B(t = 44.6 \text{ s}) - T_i] = 10 \times 10^{-3} \text{ m} \times 385 \text{ J/kg}\cdot\text{K} \times [107.1 - 25]^\circ\text{C} + 10 \times 10^{-3} \text{ m} \times 903 \text{ J/kg}\cdot\text{K} \times [90 - 25]^\circ\text{C} = 903 \text{ J/m}^2$ . For part (b) the increase in thermal energy is  $\Delta E_{st}'' = 10 \times 10^{-3} \text{ m} \times 385 \text{ J/kg}\cdot\text{K} \times [90 - 25]^\circ\text{C} + 10 \times 10^{-3} \text{ m} \times 903 \text{ J/kg}\cdot\text{K} \times [113.9 - 25]^\circ\text{C} = 1053 \text{ J/m}^2$ . The difference between the two values is due to differences in the cumulative convective losses from the top surface for the two configurations. Why are convective heat losses smaller in part (b) than in part (a)? (4) The IHT Code used to solve Equations 1 and 2 is shown below. A time step of  $\Delta t = 0.1 \text{ s}$  was specified.

```
//Dimensions
LA = 10/1000 //m
LB = 10/1000 //m

//Properties
cA = 385 //Copper specific heat, J/kgK
rhoA = 8933 //Copper density, kg/m^3
cB = 903 //Aluminum specific heat, J/kgK
rhoB = 2702 //Aluminum density, kg/m^3

//Thermal Conditions
Tinf = 25 //Ambient temperature, C
h = 40 //Convection coefficient, W/m^2K
Rcont = 400*10^-6 //Contact resistance, m^2K/W
qflux = 100*10^3 //Heat flux, W/m^2

//Copper on Bottom Case
//Energy Balance on A
//rhoA*LA*cA*Der(TA,t) = qflux - (TA - TB)/Rcont
//Energy Balance on B
//rhoB*LB*cB*Der(TB,t) = (TA - TB)/Rcont - h*(TB - Tinf)

//Copper on Top Case
//Energy Balance on A
rhoA*LA*cA*Der(TA,t) = (TB - TA)/Rcont - h*(TA - Tinf)
//Energy Balance on B
rhoB*LB*cB*Der(TB,t) = qflux - (TB - TA)/Rcont
```

### PROBLEM 5.36

**KNOWN:** Droplet properties, diameter, velocity and initial and final temperatures.

**FIND:** Travel distance and rejected thermal energy.

**SCHEMATIC:**

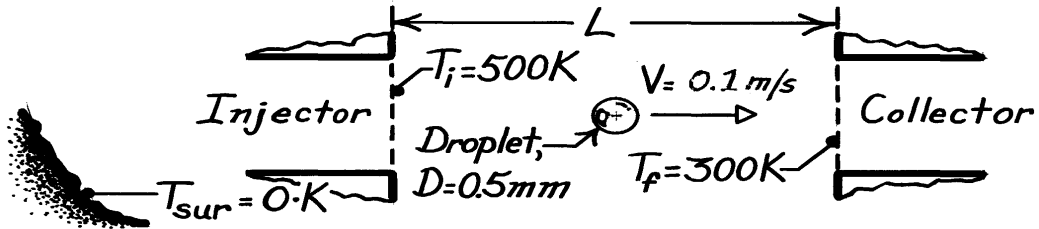

**ASSUMPTIONS:** (1) Constant properties, (2) Negligible radiation from space.

**PROPERTIES:** Droplet (given):  $\rho = 885\text{ kg/m}^3$ ,  $c = 1900\text{ J/kg}\cdot\text{K}$ ,  $k = 0.145\text{ W/m}\cdot\text{K}$ ,  $\varepsilon = 0.95$ .

**ANALYSIS:** To assess the suitability of applying the lumped capacitance method, use Equation 1.9 to obtain the maximum radiation coefficient, which corresponds to  $T = T_i$ .

$$h_r = \varepsilon\sigma T_i^3 = 0.95 \times 5.67 \times 10^{-8}\text{ W/m}^2 \cdot \text{K}^4 (500\text{ K})^3 = 6.73\text{ W/m}^2 \cdot \text{K}.$$

Hence

$$Bi_r = \frac{h_r (r_o/3)}{k} = \frac{(6.73\text{ W/m}^2 \cdot \text{K})(0.25 \times 10^{-3}\text{ m/3})}{0.145\text{ W/m}\cdot\text{K}} = 0.0039$$

and the lumped capacitance method can be used. From Equation 5.19,

$$t = \frac{L}{V} = \frac{\rho c (\pi D^3/6)}{3\varepsilon (\pi D^2)\sigma} \left( \frac{1}{T_f^3} - \frac{1}{T_i^3} \right)$$

$$L = \frac{(0.1\text{ m/s})885\text{ kg/m}^3 (1900\text{ J/kg}\cdot\text{K})0.5 \times 10^{-3}\text{ m}}{18 \times 0.95 \times 5.67 \times 10^{-8}\text{ W/m}^2 \cdot \text{K}^4} \left( \frac{1}{300^3} - \frac{1}{500^3} \right) \frac{1}{\text{K}^3}$$

$$L = 2.52\text{ m.} \quad <$$

The amount of energy rejected by each droplet is equal to the change in its internal energy.

$$E_i - E_f = \rho V c (T_i - T_f) = 885\text{ kg/m}^3 \pi \frac{(5 \times 10^{-4}\text{ m})^3}{6} 1900\text{ J/kg}\cdot\text{K} (200\text{ K})$$

$$E_i - E_f = 0.022\text{ J.} \quad <$$

**COMMENTS:** Because some of the radiation emitted by a droplet will be intercepted by other droplets in the stream, the foregoing analysis overestimates the amount of heat dissipated by radiation to space.

### PROBLEM 5.37

**KNOWN:** Diameters, initial temperature and thermophysical properties of WC and Co in composite particle. Convection coefficient and freestream temperature of plasma gas. Melting point and latent heat of fusion of Co.

**FIND:** Times required to reach melting and to achieve complete melting of Co.

**SCHEMATIC:**

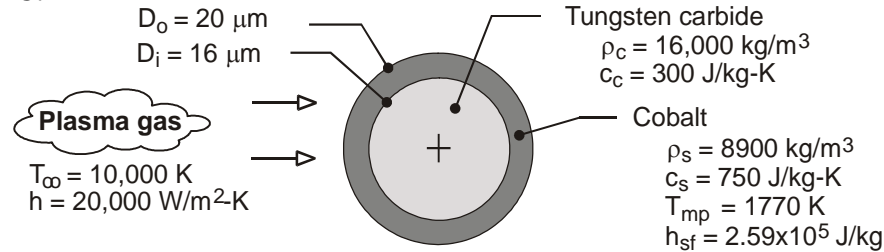

**ASSUMPTIONS:** (1) Particle is isothermal at any instant, (2) Radiation exchange with surroundings is negligible, (3) Negligible contact resistance at interface between WC and Co, (4) Constant properties.

**ANALYSIS:** From Eq. (5.5), the time required to reach the melting point is

$$t_1 = \frac{(\rho V c)_{\text{tot}}}{h \pi D_o^2} \ln \frac{T_i - T_\infty}{T_{\text{mp}} - T_\infty}$$

where the total heat capacity of the composite particle is

$$\begin{aligned} (\rho V c)_{\text{tot}} &= (\rho V c)_c + (\rho V c)_s = 16,000 \text{ kg/m}^3 \left[ \pi (1.6 \times 10^{-5} \text{ m})^3 / 6 \right] 300 \text{ J/kg} \cdot \text{K} \\ &+ 8900 \text{ kg/m}^3 \left\{ \pi / 6 \left[ (2.0 \times 10^{-5} \text{ m})^3 - (1.6 \times 10^{-5} \text{ m})^3 \right] \right\} 750 \text{ J/kg} \cdot \text{K} \\ &= (1.03 \times 10^{-8} + 1.36 \times 10^{-8}) \text{ J/K} = 2.39 \times 10^{-8} \text{ J/K} \end{aligned}$$

$$t_1 = \frac{2.39 \times 10^{-8} \text{ J/K}}{(20,000 \text{ W/m}^2 \cdot \text{K}) \pi (2.0 \times 10^{-5} \text{ m})^2} \ln \frac{(300 - 10,000) \text{ K}}{(1770 - 10,000) \text{ K}} = 1.56 \times 10^{-4} \text{ s} <$$

The time required to melt the Co may be obtained by applying the first law, Eq. (1.12b) to a control surface about the particle. It follows that

$$\begin{aligned} E_{\text{in}} &= h \pi D_o^2 (T_\infty - T_{\text{mp}}) t_2 = \Delta E_{\text{st}} = \rho_s (\pi / 6) (D_o^3 - D_i^3) h_{\text{sf}} \\ t_2 &= \frac{8900 \text{ kg/m}^3 (\pi / 6) \left[ (2 \times 10^{-5} \text{ m})^3 - (1.6 \times 10^{-5} \text{ m})^3 \right] 2.59 \times 10^5 \text{ J/kg}}{(20,000 \text{ W/m}^2 \cdot \text{K}) \pi (2 \times 10^{-5} \text{ m})^2 (10,000 - 1770) \text{ K}} = 2.28 \times 10^{-5} \text{ s} < \end{aligned}$$

**COMMENTS:** (1) The largest value of the radiation coefficient corresponds to  $h_r = \varepsilon \sigma (T_{\text{mp}} + T_{\text{sur}}) (T_{\text{mp}}^2 + T_{\text{sur}}^2)$ . For the maximum possible value of  $\varepsilon = 1$  and  $T_{\text{sur}} = 300 \text{ K}$ ,  $h_r = 378 \text{ W/m}^2 \cdot \text{K} \ll h = 20,000 \text{ W/m}^2 \cdot \text{K}$ . Hence, the assumption of negligible radiation exchange is excellent. (2) Despite the large value of  $h$ , the small values of  $D_o$  and  $D_i$  and the large thermal conductivities ( $\sim 40 \text{ W/m} \cdot \text{K}$  and  $70 \text{ W/m} \cdot \text{K}$  for WC and Co, respectively) render the lumped capacitance approximation a good one. (3) A detailed treatment of plasma heating of a composite powder particle is provided by Demetriou, Lavine and Ghoniem (Proc. 5<sup>th</sup> ASME/JSME Joint Thermal Engineering Conf., March, 1999).



### PROBLEM 5.38

**KNOWN:** Diameter of highly polished aluminum rod. Temperature of rod initially and at two later times. Room air temperature.

**FIND:** Values of constants  $C$  and  $n$  in Equation 5.26. Plot rod temperature vs. time for varying and constant heat transfer coefficients.

**SCHEMATIC:**

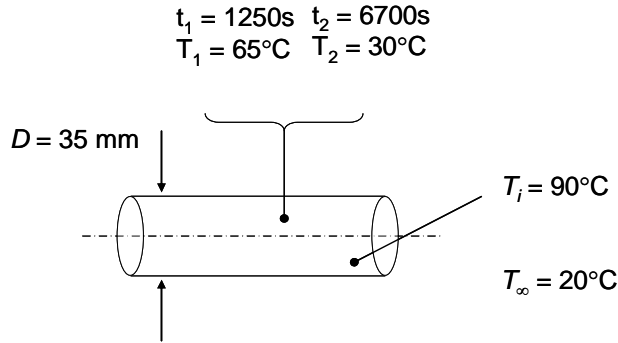

**ASSUMPTIONS:** (1) Constant properties, (2) Radiation negligible because rod is highly polished, (3) Lumped capacitance approximation is valid.

**PROPERTIES:** Table A.1, Aluminum ( $T = 328\text{ K}$ ):  $c = 916\text{ J/kg}\cdot\text{K}$ ,  $\rho = 2702\text{ kg/m}^3$ ,  $k = 238\text{ W/m}\cdot\text{K}$ .

**ANALYSIS:** If the heat transfer coefficient is given by Equation 5.26, then the temperature as a function of time is given by Equation 5.28:

$$\frac{\theta}{\theta_i} = \left[ \frac{nCA_{s,c}\theta_i^n}{\rho Vc} t + 1 \right]^{-1/n} \quad (1)$$

where  $\theta = T - T_\infty$  and  $A_{s,c}$  is the area exposed to convection,  $A_{s,c} = \pi DL$ . Since the rod temperature is known at two different times, Equation (1) can be evaluated at these two times, making it possible to solve for the two unknowns,  $C$  and  $n$ . The two equations are

$$\frac{\theta_1}{\theta_i} = \left[ \frac{nCA_{s,c}\theta_i^n}{\rho Vc} t_1 + 1 \right]^{-1/n} \quad \frac{\theta_2}{\theta_i} = \left[ \frac{nCA_{s,c}\theta_i^n}{\rho Vc} t_2 + 1 \right]^{-1/n} \quad (2a,b)$$

These equations cannot be explicitly solved for  $C$  and  $n$ . They can be numerically solved in this form, using IHT or some other software, or they can be further manipulated to solve for the times:

$$t_1 = \left[ \left( \frac{\theta_1}{\theta_i} \right)^{-n} - 1 \right] \frac{\rho c D}{4n C \theta_i^n} \quad t_2 = \left[ \left( \frac{\theta_2}{\theta_i} \right)^{-n} - 1 \right] \frac{\rho c D}{4n C \theta_i^n} \quad (3a,b)$$

where we have used  $V/A_{s,c} = D/4$ . Taking the ratio of Equations (3a) and (3b) yields

$$\frac{t_2}{t_1} = \frac{\left( \frac{\theta_2}{\theta_i} \right)^{-n} - 1}{\left( \frac{\theta_1}{\theta_i} \right)^{-n} - 1} = \frac{6700\text{ s}}{1250\text{ s}} = \frac{\left( \frac{30^\circ\text{C} - 20^\circ\text{C}}{90^\circ\text{C} - 20^\circ\text{C}} \right)^{-n} - 1}{\left( \frac{65^\circ\text{C} - 20^\circ\text{C}}{90^\circ\text{C} - 20^\circ\text{C}} \right)^{-n} - 1} = 5.36 = \frac{(0.143)^{-n} - 1}{(0.643)^{-n} - 1} \quad (4a,b,c)$$

Continued...

### PROBLEM 5.38 (Cont.)

This can be iteratively or numerical solved for  $n$ , to find  $n = 0.25$ . Then  $C$  can be determined from Equation (3a) or (3b):

$$C = \left[ \left( \frac{\theta_1}{\theta_i} \right)^{-n} - 1 \right] \frac{\rho c D}{4n\theta_i^n t_1} = \left[ \left( \frac{45^\circ\text{C}}{70^\circ\text{C}} \right)^{-0.25} - 1 \right] \frac{2702 \text{ kg/m}^3 \times 916 \text{ J/kg} \cdot \text{K} \times 0.035 \text{ m}}{4 \times 0.25 \times (70^\circ\text{C})^{0.25} \times 1250 \text{ s}} = 2.8 \text{ W/m}^2 \cdot \text{K}^{1.25}$$

$$C = 2.8 \text{ W/m}^2 \cdot \text{K}^{1.25}, n = 0.25$$

<

Now that these constants are known, the validity of the lumped capacitance approximation can be checked. The maximum heat transfer coefficient occurs at the initial time,

$$h = C(T - T_\infty)^n = 2.8 \text{ W/m}^2 \cdot \text{K}^{1.25} [(90 - 20)\text{K}]^{0.25} = 8.1 \text{ W/m}^2 \cdot \text{K}$$

Thus, using the conservative definition,  $Bi = hD/2k = 6 \times 10^{-4}$ . The lumped capacitance approximation is valid.

The heat transfer coefficient corresponding to a rod temperature of  $\bar{T} = (T_i + T_\infty)/2 = 55^\circ\text{C}$  is

$$h = C(T - T_\infty)^n = 2.8 \text{ W/m}^2 \cdot \text{K}^{1.25} [(55 - 20)\text{K}]^{0.25} = 6.8 \text{ W/m}^2 \cdot \text{K}$$

The plot below shows the rod temperature as a function of time using Equation (1) above for variable heat transfer coefficient, as well as the rod temperature assuming the constant value of  $h = 6.8 \text{ W/m}^2 \cdot \text{K}$ , using text Equation 5.6.

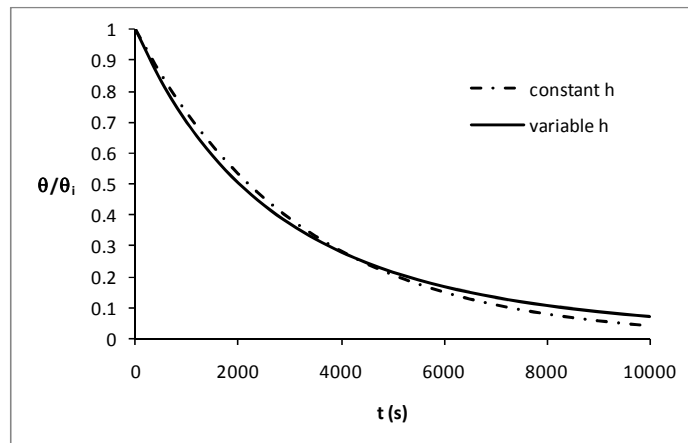

<

**COMMENTS:** (1) Since the heat transfer coefficient is temperature difference-dependent (variable  $h$ ), the initial cooling rates are larger when this dependence is accounted for. As the temperature difference decreases, the variable  $h$  case cools slower relative to the constant  $h$  case. (2) The discrepancy between the variable and constant heat transfer coefficient cases is not large under these conditions. The difference would be greater if  $n$  were larger.

### PROBLEM 5.39

**KNOWN:** Dimensions, initial temperature and thermophysical properties of chip, solder and substrate. Temperature and convection coefficient of heating agent.

**FIND:** (a) Time constants and temperature histories of chip, solder and substrate when heated by an air stream. Time corresponding to maximum stress on a solder ball. (b) Reduction in time associated with using a dielectric liquid to heat the components.

**SCHEMATIC:**

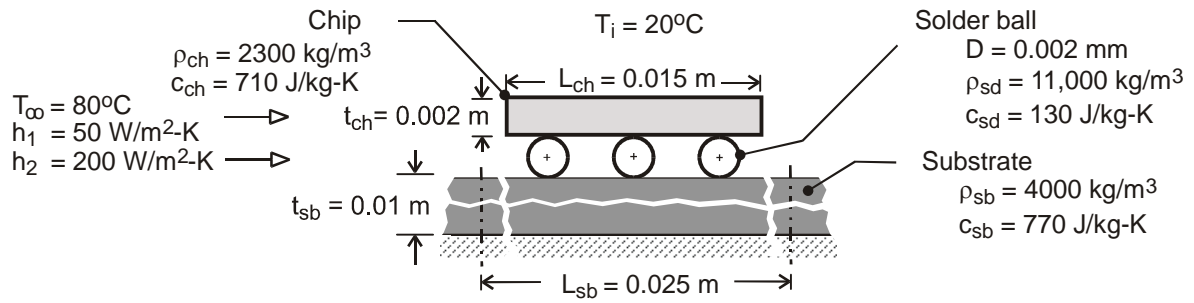

**ASSUMPTIONS:** (1) Lumped capacitance analysis is valid for each component, (2) Negligible heat transfer between components, (3) Negligible reduction in surface area due to contact between components, (4) Negligible radiation for heating by air stream, (5) Uniform convection coefficient among components, (6) Constant properties.

**ANALYSIS:** (a) From Eq. (5.7),  $\tau_t = (\rho Vc)/hA$

$$\text{Chip: } V = (L_{ch}^2) t_{ch} = (0.015\text{ m})^2 (0.002\text{ m}) = 4.50 \times 10^{-7}\text{ m}^3, A_s = (2L_{ch}^2 + 4L_{ch} t_{ch}) \\ = 2(0.015\text{ m})^2 + 4(0.015\text{ m})(0.002\text{ m}) = 5.70 \times 10^{-4}\text{ m}^2$$

$$\tau_t = \frac{2300\text{ kg/m}^3 \times 4.50 \times 10^{-7}\text{ m}^3 \times 710\text{ J/kg}\cdot\text{K}}{50\text{ W/m}^2\cdot\text{K} \times 5.70 \times 10^{-4}\text{ m}^2} = 25.8\text{ s} \quad <$$

$$\text{Solder: } V = \pi D^3 / 6 = \pi (0.002\text{ m})^3 / 6 = 4.19 \times 10^{-9}\text{ m}^3, A_s = \pi D^2 = \pi (0.002\text{ m})^2 = 1.26 \times 10^{-5}\text{ m}^2$$

$$\tau_t = \frac{11,000\text{ kg/m}^3 \times 4.19 \times 10^{-9}\text{ m}^3 \times 130\text{ J/kg}\cdot\text{K}}{50\text{ W/m}^2\cdot\text{K} \times 1.26 \times 10^{-5}\text{ m}^2} = 9.5\text{ s} \quad <$$

$$\text{Substrate: } V = (L_{sb}^2 t_{sb}) = (0.025\text{ m})^2 (0.01\text{ m}) = 6.25 \times 10^{-6}\text{ m}^3, A_s = L_{sb}^2 = (0.025\text{ m})^2 = 6.25 \times 10^{-4}\text{ m}^2$$

$$\tau_t = \frac{4000\text{ kg/m}^3 \times 6.25 \times 10^{-6}\text{ m}^3 \times 770\text{ J/kg}\cdot\text{K}}{50\text{ W/m}^2\cdot\text{K} \times 6.25 \times 10^{-4}\text{ m}^2} = 616.0\text{ s} \quad <$$

Substituting Eq. (5.7) into (5.5) and recognizing that  $(T - T_i)/(T_\infty - T_i) = 1 - (\theta/\theta_i)$ , in which case  $(T - T_i)/(T_\infty - T_i) = 0.99$  yields  $\theta/\theta_i = 0.01$ , it follows that the time required for a component to experience 99% of its maximum possible temperature rise is

$$t_{0.99} = \tau \ln(\theta_i / \theta) = \tau \ln(100) = 4.61 \tau$$

Hence,

$$\text{Chip: } t = 118.9\text{ s}, \quad \text{Solder: } t = 43.8\text{ s}, \quad \text{Substrate: } t = 2840 \quad <$$

Continued ...

### PROBLEM 5.39 (Cont.)

Histories of the three components and temperature differences between a solder ball and its adjoining components are shown below.

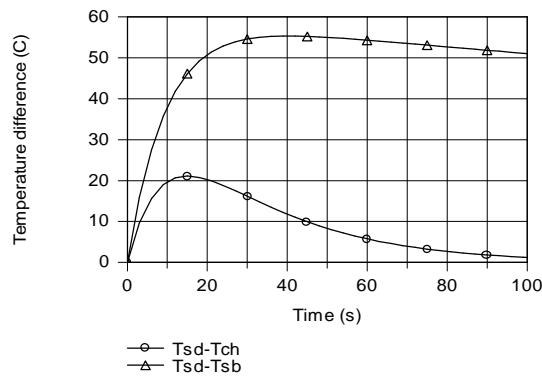
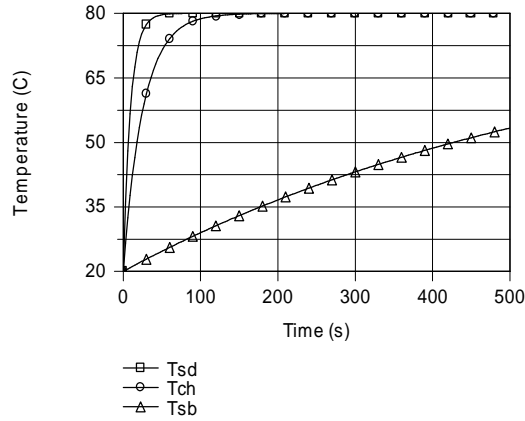

Commensurate with their time constants, the fastest and slowest responses to heating are associated with the solder and substrate, respectively. Accordingly, the largest temperature difference is between these two components, and it achieves a maximum value of 55°C at

$$t(\text{maximum stress}) \approx 40\text{s}$$

<

(b) With the 4-fold increase in  $h$  associated with use of a dielectric liquid to heat the components, the time constants are each reduced by a factor of 4, and the times required to achieve 99% of the maximum temperature rise are

$$\text{Chip: } t = 29.5\text{s}, \quad \text{Solder: } t = 11.0\text{s}, \quad \text{Substrate: } t = 708\text{s}$$

<

The time savings is approximately 75%.

**COMMENTS:** The foregoing analysis provides only a first, albeit useful, approximation to the heating problem. Several of the assumptions are highly approximate, particularly that of a uniform convection coefficient. The coefficient will vary between components, as well as on the surfaces of the components. Also, because the solder balls are flattened, there will be a reduction in surface area exposed to the fluid for each component, as well as heat transfer between components, which reduces differences between time constants for the components.

### PROBLEM 5.40

**KNOWN:** Electrical transformer of approximate cubical shape, 32 mm to a side, dissipates 4.0 W when operating in ambient air at 20°C with a convection coefficient of 10 W/m<sup>2</sup>·K.

**FIND:** (a) Develop a model for estimating the steady-state temperature of the transformer,  $T(\infty)$ , and evaluate  $T(\infty)$ , for the operating conditions, and (b) Develop a model for estimating the temperature-time history of the transformer if initially the temperature is  $T_i = T_\infty$  and suddenly power is applied. Determine the time required to reach within 5°C of its steady-state operating temperature.

**SCHEMATIC:**

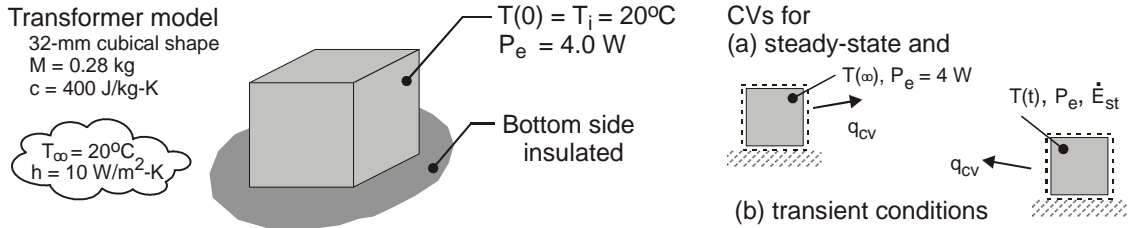

**ASSUMPTIONS:** (1) Transformer is spatially isothermal object, (2) Initially object is in equilibrium with its surroundings, (3) Bottom surface is adiabatic.

**ANALYSIS:** (a) Under steady-state conditions, for the control volume shown in the schematic above, the energy balance is

$$\dot{E}_{in} - \dot{E}_{out} + \dot{E}_{gen} = 0 \quad 0 - q_{cv} + P_e = -h A_s [T(\infty) - T_\infty] + P_e = 0 \quad (1)$$

where  $A_s = 5 \times L^2 = 5 \times 0.032\text{m} \times 0.032\text{m} = 5.12 \times 10^{-3} \text{m}^2$ , find

$$T(\infty) = T_\infty + P_e / h A_s = 20^\circ\text{C} + 4 \text{ W} / (10 \text{ W/m}^2 \cdot \text{K} \times 5.12 \times 10^{-3} \text{m}^2) = 98.1^\circ\text{C} <$$

(b) Under transient conditions, for the control volume shown above, the energy balance is

$$\dot{E}_{in} - \dot{E}_{out} + \dot{E}_{gen} = \dot{E}_{st} \quad 0 - q_{cv} + P_e = Mc \frac{dT}{dt} \quad (2)$$

Substitute from Eq. (1) for  $P_e$ , separate variables, and define the limits of integration.

$$-h [T(t) - T_\infty] + h [T(\infty) - T_\infty] = Mc \frac{dT}{dt}$$

$$-h [T(t) - T(\infty)] = Mc \frac{d}{dt} (T - T(\infty)) \quad \frac{h}{Mc} \int_0^{t_o} dt = -\int_{\theta_i}^{\theta_o} \frac{d\theta}{\theta}$$

where  $\theta = T(t) - T(\infty)$ ;  $\theta_i = T_i - T(\infty) = T_\infty - T(\infty)$ ; and  $\theta_o = T(t_o) - T(\infty)$  with  $t_o$  as the time when  $\theta_o = -5^\circ\text{C}$ . Integrating and rearranging find (see Eq. 5.5),

$$t_o = \frac{Mc}{h A_s} \ln \frac{\theta_i}{\theta_o}$$

$$t_o = \frac{0.28 \text{ kg} \times 400 \text{ J/kg} \cdot \text{K}}{10 \text{ W/m}^2 \cdot \text{K} \times 5.12 \times 10^{-3} \text{m}^2} \ln \frac{(20 - 98.1)^\circ\text{C}}{-5^\circ\text{C}} = 1.67 \text{ hour} <$$

**COMMENTS:** The spacewise isothermal assumption may not be a gross over simplification since most of the material is copper and iron, and the external resistance by free convection is high.

However, by ignoring internal resistance, our estimate for  $t_o$  is optimistic.

### PROBLEM 5.41

**KNOWN:** Mass and exposed surface area of a silicon cantilever, convection heat transfer coefficient, initial and ambient temperatures.

**FIND:** (a) The ohmic heating needed to raise the cantilever temperature from  $T_i = 300 \text{ K}$  to  $T = 1000 \text{ K}$  in  $t_h = 1 \mu\text{s}$ , (b) The time required to cool the cantilever from  $T = 1000 \text{ K}$  to  $T = 400 \text{ K}$ ,  $t_c$  and the thermal processing time ( $t_p = t_h + t_c$ ), (c) The number of bits that can be written onto a  $1 \text{ mm} \times 1 \text{ mm}$  surface area and time needed to write the data for a processing head equipped with  $M$  cantilevers.

**SCHEMATIC:**

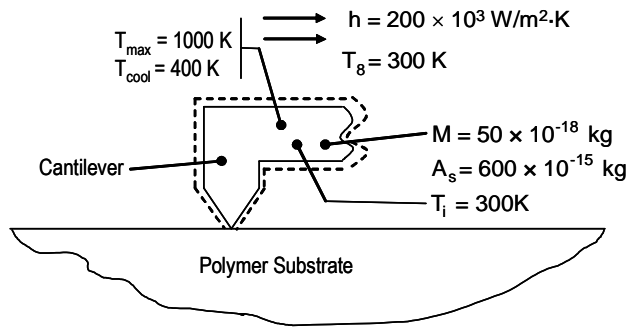

**ASSUMPTIONS:** (1) Lumped capacitance behavior, (2) Negligible radiation heat transfer, (3) Constant properties, (4) Negligible heat transfer to polymer substrate.

**PROPERTIES:** Table A.1, silicon ( $\bar{T} = 650 \text{ K}$ ):  $c_p = 878.5 \text{ J/kg}\cdot\text{K}$ .

**ANALYSIS:**

(a) From Problem 5.20 we note that

$$\frac{\theta}{\theta_i} = \exp\left(-\frac{t}{RC}\right) \quad (1)$$

where  $\theta \equiv T - T(\infty)$  and  $T(\infty)$  is the steady-state temperature corresponding to  $t \rightarrow \infty$ ;

$\theta_i = T_i - T(\infty)$ ,  $R = \frac{1}{hA_s}$ , and  $C = Mc_p$ . For this problem,

$$R = \frac{1}{200 \times 10^3 \text{ W/m}^2 \cdot \text{K} \times 600 \times 10^{-15} \text{ m}^2} = 8.33 \times 10^6 \text{ K/W}$$

$$C = 50 \times 10^{-18} \text{ kg} \times 878.5 \text{ J/kg} \cdot \text{K} = 43.9 \times 10^{-15} \text{ J/K}$$

$$R \times C = 8.33 \times 10^6 \text{ K/W} \times 43.9 \times 10^{-15} \text{ J/K} = 366 \times 10^{-9} \text{ s}$$

Therefore, Equation 1 may be evaluated as

Continued...

**PROBLEM 5.41 (Cont.)**

$$\frac{1000 - T(\infty)}{300 - T(\infty)} = \exp\left(-\frac{1 \times 10^{-6} \text{ s}}{366 \times 10^{-9} \text{ s}}\right) = 0.0651$$

hence,  $T(\infty) = 1049\text{K}$ .

At steady-state, Equation 1.12b yields

$$\begin{aligned} \dot{E}_g &= hA_s(T(\infty) - T_\infty) = 200 \times 10^3 \text{ W/m}^2 \cdot \text{K} \times 600 \times 10^{-15} \text{ m}^2 (1049 - 300) \text{ K} \\ &= 90 \times 10^{-6} \text{ W} = 90 \mu\text{W} \end{aligned} \quad <$$

(b) Equation 5.6 may be used. Hence,

$$\frac{\theta}{\theta_i} = \exp\left[-\left(\frac{hA_s}{Mc}\right)t_c\right] \quad \text{where } \theta = T - T_\infty. \text{ Therefore}$$

$$\frac{400 - 300}{1000 - 300} = 0.143 = \exp\left[-\left(\frac{200 \times 10^3 \text{ W/m}^2 \cdot \text{K} \times 600 \times 10^{-15} \text{ m}^2}{50 \times 10^{-18} \text{ kg} \times 878.5 \text{ J/kg} \cdot \text{K}}\right)t_c\right]$$

$$\text{or } t_c = 0.71 \times 10^{-6} \text{ s} = 0.71 \mu\text{s} \quad <$$

$$\text{and } t_p = t_h + t_c = 1.0 \mu\text{s} + 0.71 \mu\text{s} = 1.71 \mu\text{s} \quad <$$

(c) Each bit occupies  $A_b = 50 \times 10^{-9} \text{ m} \times 50 \times 10^{-9} \text{ m} = 2.5 \times 10^{-15} \text{ m}^2$

Therefore, the number of bits on a  $1 \text{ mm} \times 1 \text{ mm}$  substrate is

$$N = \frac{1 \times 10^{-3} \times 1 \times 10^{-3} \text{ m}^2}{2.5 \times 10^{-15} \text{ m}^2} = 400 \times 10^6 \text{ bits} \quad <$$

The total time needed to write the data ( $t_t$ ) is,

$$t_t = \frac{N \times t_p}{M} = \frac{400 \times 10^6 \text{ bits} \times 1.71 \times 10^{-6} \text{ s/bit}}{100} = 6.84 \text{ s} \quad <$$

**COMMENTS:** (1) Lumped thermal capacitance behavior is an excellent approximation for such a small device (2) Each cantilever writes  $N/M = 400 \times 10^6 \text{ bits}/100 \text{ cantilevers} = 400 \times 10^4 \text{ bits/cantilever}$ . With a separation distance of  $50 \times 10^{-9} \text{ m}$ , the total distance traveled is  $50 \times 10^{-9} \text{ m} \times 400 \times 10^4 = 200 \times 10^{-3} \text{ m} = 200 \text{ mm}$ . If the head travels at  $200 \text{ mm/s}$ , it will take 1 second to move the head, providing a total writing and moving time of  $6.84 \text{ s} + 1 \text{ s} = 7.84 \text{ s}$ . The speed of the process is heat transfer-limited.

## PROBLEM 5.42

**KNOWN:** Ambient conditions, initial water droplet temperature and diameter.

**FIND:** Total time to completely freeze the water droplet for (a) droplet solidification at  $T_f = 0^\circ\text{C}$  and (b) rapid solidification of the droplet at  $T_{f,sc}$ .

**SCHEMATIC:**

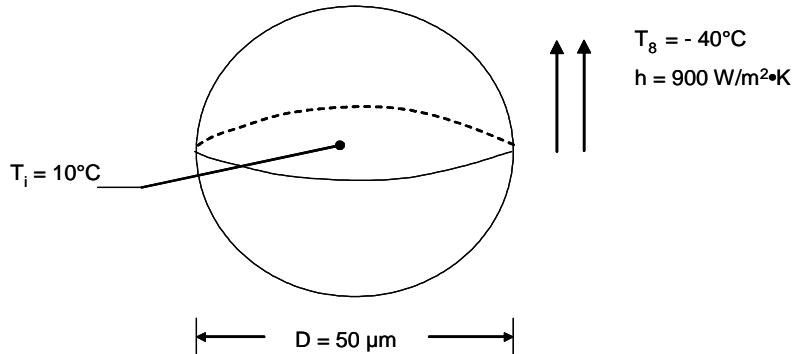

**ASSUMPTIONS:** (1) Isothermal particle, (2) Negligible radiation heat transfer, (3) Constant properties.

**PROPERTIES:** Table A.6, liquid water ( $T = 0^\circ\text{C}$ ):  $c_p = 4217 \text{ J/kg}\cdot\text{K}$ ,  $k = 0.569 \text{ W/m}\cdot\text{K}$ ,  $\rho = 1000 \text{ kg/m}^3$ . Example 1.6:  $h_{sf} = 334 \text{ kJ/kg}$ .

**ANALYSIS:** We begin by evaluating the validity of the lumped capacitance method by determining the value of the Biot number.

$$Bi_i = \frac{hL_c}{k} = \frac{hD/3}{k} = \frac{900 \text{ W/m}^2 \cdot \text{K} \times 50 \times 10^{-6} \text{ m}/3}{0.569 \text{ W/m} \cdot \text{K}} = 0.026 \ll 0.1$$

Hence, the lumped capacitance approach is valid.

Case A: Equilibrium solidification,  $T_f = 0^\circ\text{C}$ .

The solidification process occurs in two steps. The first step involves cooling the drop to  $T_f = 0^\circ\text{C}$  while the drop is completely liquid. Hence, Equation 5.6 is used where

$$A = \pi D^2 = \pi \times (50 \times 10^{-6} \text{ m})^2 = 7.85 \times 10^{-9} \text{ m}^2 \text{ and}$$

$V = 4\pi(D/2)^3/3 = 4 \times \pi \times (50 \times 10^{-6} \text{ m}/2)^3/3 = 65.4 \times 10^{-15} \text{ m}^3$ . Equation 5.6 may be rearranged to yield

$$t_1 = - \frac{\rho V c}{hA} \ln \left[ \frac{T - T_\infty}{T_i - T_\infty} \right] \quad (1)$$

$$= - \frac{1000 \text{ kg/m}^3 \times 65.4 \times 10^{-15} \text{ m}^3 \times 4217 \text{ J/kg}\cdot\text{K}}{900 \text{ W/m}^2 \times 7.85 \times 10^{-9} \text{ m}^2} \times \ln \left[ \frac{0 - (-40^\circ\text{C})}{10^\circ\text{C} - (-40^\circ\text{C})} \right]$$

$$t_1 = 8.7 \times 10^{-3} \text{ s} = 8.7 \text{ ms}$$

Continued...



### PROBLEM 5.42 (Cont.)

The second step involves solidification of the ice, which occurs at  $T_f = 0^\circ\text{C}$ . An energy balance on the droplet yields

$$-E_{\text{out}} = \Delta E_{\text{st}} \quad \text{or} \quad -hA(T_f - T_\infty)t_2 = \rho V h_{\text{sf}}$$

which may be rearranged to provide

$$\begin{aligned} t_2 &= - \frac{\rho V h_{\text{sf}}}{hA(T_f - T_\infty)} \\ &= \frac{1000 \text{ kg/m}^3 \times 65.4 \times 10^{-15} \text{ m}^3 \times 334,000 \text{ J/kg}}{900 \text{ W/m}^2 \times 7.85 \times 10^{-9} \text{ m}^2 \times (0^\circ\text{C} - (-40^\circ\text{C}))} = 77.3 \times 10^{-3} \text{ s} = 77.3 \text{ ms} \end{aligned} \quad (2)$$

The time needed to cool and solidify the particle is

$$t = t_1 + t_2 = 8.7 \text{ ms} + 77.3 \text{ ms} = 86 \text{ ms} \quad <$$

Case B: Rapid solidification at  $T_{f,\text{sc}}$ .

Using the expression given in the problem statement, the liquid droplet is supercooled to a temperature of  $T_{f,\text{sc}}$  prior to freezing.

$$T_{f,\text{sc}} = -28 + 1.87 \ln(50 \times 10^{-6} \text{ m}) = -36.6^\circ\text{C}$$

The solidification process occurs in multiple steps, the first of which is cooling the particle to  $T_{f,\text{sc}} = -36.6^\circ\text{C}$ . Substituting  $T = T_{f,\text{sc}}$  into Equation 1 yields

$$t_1 = 105 \times 10^{-3} \text{ s} = 105 \text{ ms}$$

The second step involves rapid solidification of some or all of the supercooled liquid. An energy balance on the particle yields

$$\dot{E}_{\text{st}} = 0 = \rho V h_{\text{sf}} f = \rho V c (T_f - T_{f,\text{sc}}) \quad (3)$$

where  $f$  is the fraction of the mass in the droplet that is converted to ice. Solving the preceding equation for  $f$  yields

$$f = \frac{c(T_f - T_{f,\text{sc}})}{h_{\text{sf}}} = \frac{4217 \text{ J/kg} \cdot \text{K} \times (0^\circ\text{C} - (-36.6^\circ\text{C}))}{334,000 \text{ J/kg}} = 0.462$$

Hence, immediately after the rapid solidification, the water droplet is approximately 46% ice and 54% liquid. The time required for the rapid solidification is  $t_2 \approx 0 \text{ s}$ .

The third stage of Case B involves the time required to freeze the remaining liquid water,  $t_3$ . Equation 2 is modified accordingly to yield

$$\begin{aligned} t_3 &= - \frac{(1-f)\rho V h_{\text{sf}}}{hA(T_f - T_\infty)} \\ &= - \frac{(1 - 0.462) \times 1000 \text{ kg/m}^3 \times 65.4 \times 10^{-15} \text{ m}^3 \times 334,000 \text{ J/kg}}{900 \text{ W/m}^2 \times 7.85 \times 10^{-9} \text{ m}^2 \times (0^\circ\text{C} - (-40^\circ\text{C}))} = 42 \times 10^{-3} \text{ s} = 42 \text{ ms} \end{aligned}$$

Continued...

### PROBLEM 5.42 (Cont.)

The total time to solidify the particle is

$$t = t_1 + t_2 + t_3 = 105 \text{ ms} + 0 + 42 \text{ s} = 147 \text{ ms}$$

<

The temperature histories associated with Case A and Case B are shown in the sketch below.

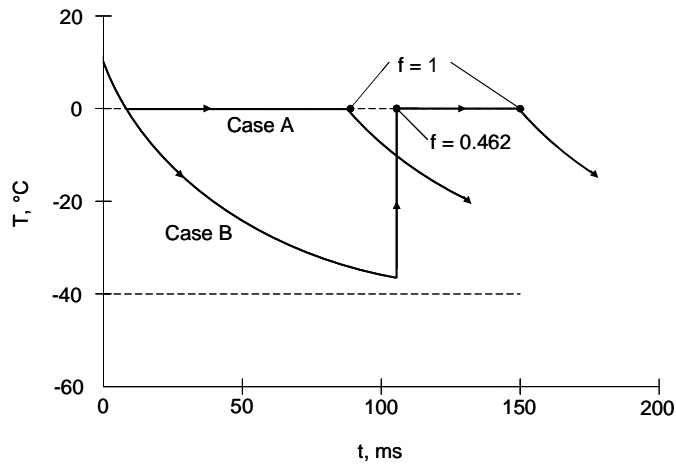

**COMMENTS:** (1) Equation 3 may be derived by assuming a reference temperature of  $T_f = 0 \text{ }^\circ\text{C}$  and a liquid reference state. The energy of the particle prior to the rapid solidification is  $E_1 = \rho V c (T_{f,sc} - T_f)$ . The energy of the particle after the rapid solidification is  $E_2 = -f \rho V h_{sf} + (1 - f) \rho V c (T_f - T_f) = -f \rho V h_{sf}$ . Setting  $E_1 = E_2$  yields Equation 3. (2) The average temperature of the supercooled particle is significantly lower than the average temperature of the particle of Case A. Hence, the rate at which the supercooled particle of Case B is cooled by the cold air is, on average, much less than the particle of Case A. Since both particles ultimately reach the same state (all ice at  $T = 0 \text{ }^\circ\text{C}$ ), it takes longer to completely solidify the supercooled particle. (3) For Case A, the ice particle at  $T = 0 \text{ }^\circ\text{C}$  will be a solid sphere, sometimes referred to as *sleet*. For Case B, the rapid solidification will result in a *snowflake*.

### PROBLEM 5.43

**KNOWN:** Series solution, Eq. 5.42, for transient conduction in a plane wall with convection.

**FIND:** Midplane ( $x^*=0$ ) and surface ( $x^*=1$ ) temperatures  $\theta^*$  for  $Fo=0.1$  and  $1$ , using  $Bi=0.1, 1$  and  $10$  with only the first four eigenvalues. Based upon these results, discuss the validity of the approximate solutions, Eqs. 5.43 and 5.44.

**SCHEMATIC:**

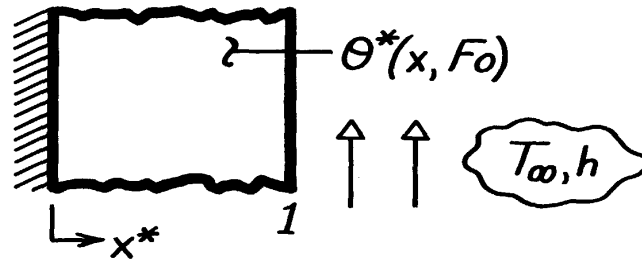

**ASSUMPTIONS:** (1) One-dimensional transient conduction, (2) Constant properties.

**ANALYSIS:** The series solution, Eq. 5.42a, is of the form,

$$\theta^* = \sum_{n=1}^{\infty} C_n \exp(-\zeta_n^2 Fo) \cos(\zeta_n x^*)$$

where the eigenvalues,  $\zeta_n$ , and the constants,  $C_n$ , are from Eqs. 5.39b and 5.39c.

$$\zeta_n \tan \zeta_n = Bi \quad C_n = 4 \sin \zeta_n / (2\zeta_n + \sin(2\zeta_n)).$$

The eigenvalues are tabulated in Appendix B.3; note, however, that  $\zeta_1$  and  $C_1$  are available from Table 5.1. The values of  $\zeta_n$  and  $C_n$  used to evaluate  $\theta^*$  are as follows:

Bi	$\zeta_1$	$C_1$	$\zeta_2$	$C_2$	$\zeta_3$	$C_3$	$\zeta_4$	$C_4$
0.1	0.3111	1.0160	3.1731	-0.0197	6.2991	0.0050	9.4354	-0.0022
1	0.8603	1.1191	3.4256	-0.1517	6.4373	0.0466	9.5293	-0.0217
10	1.4289	1.2620	4.3058	-0.3934	7.2281	0.2104	10.2003	-0.1309

Using  $\zeta_n$  and  $C_n$  values, the terms of  $\theta^*$ , designated as  $\theta_1^*$ ,  $\theta_2^*$ ,  $\theta_3^*$  and  $\theta_4^*$ , are as follows:

$x^*$	Fo=0.1					
	Bi=0.1		Bi=1.0		Bi=10	
	0	1	0	1	0	1
$\theta_1^*$	1.0062	0.9579	1.0393	0.6778	1.0289	0.1455
$\theta_2^*$	-0.0072	0.0072	-0.0469	0.0450	-0.0616	0.0244
$\theta_3^*$	0.0001	0.0001	0.0007	0.0007	0.0011	0.0006
$\theta_4^*$	$-2.99 \times 10^{-7}$	$3.00 \times 10^{-7}$	$2.47 \times 10^{-6}$	$2.46 \times 10^{-7}$	$-3.96 \times 10^{-6}$	$2.83 \times 10^{-6}$
$\theta^*$	0.9991	0.9652	0.9931	0.7235	0.9684	0.1705

Continued ...

**PROBLEM 5.43 (Cont.)**

		Fo=1					
		Bi=0.1		Bi=1.0		Bi=10	
x*		0	1	0	1	0	1
$\theta_1^*$		0.9223	0.8780	0.5339	0.3482	0.1638	0.0232
$\theta_2^*$		$8.35 \times 10^{-7}$	$8.35 \times 10^{-7}$	$-1.22 \times 10^{-5}$	$1.17 \times 10^{-6}$	$3.49 \times 10^{-9}$	$1.38 \times 10^{-9}$
$\theta_3^*$		$7.04 \times 10^{-20}$	-	$4.70 \times 10^{-20}$	-	$4.30 \times 10^{-24}$	-
$\theta_4^*$		$4.77 \times 10^{-42}$	-	$7.93 \times 10^{-42}$	-	$8.52 \times 10^{-47}$	-
$\theta^*$		0.9223	0.8780	0.5339	0.3482	0.1638	0.0232

The tabulated results for  $\theta^* = \theta^*(x^*, Bi, Fo)$  demonstrate that for Fo=1, the first eigenvalue is sufficient to accurately represent the series. However, for Fo=0.1, three eigenvalues are required for accurate representation.

A more detailed analysis would show that a practical criterion for representation of the series solution by one eigenvalue is  $Fo > 0.2$ . For these situations the approximate solutions, Eqs. 5.43 and 5.44, are appropriate. For the midplane,  $x^*=0$ , the first two eigenvalues for Fo=0.2 are:

Bi	Fo=0.2		
	x*=0		
	0.1	1.0	10
$\theta_1^*$	0.9965	0.9651	0.8389
$\theta_2^*$	-0.00226	-0.0145	-0.0096
$\theta^*$	0.9939	0.9506	0.8293
Error,%	+0.26	+1.53	+1.16

The percentage error shown in the last row of the above table is due to the effect of the second term. For Bi = 0.1, neglecting the second term provides an error of 0.26%. For Bi = 1, the error is 1.53%.

Hence we conclude that the approximate series solutions (with only one eigenvalue) provides systematically high results, but by less than 1.5%, for the Biot number range from 0.1 to 10.

### PROBLEM 5.44

**KNOWN:** One-dimensional wall, initially at a uniform temperature,  $T_i$ , is suddenly exposed to a convection process ( $T_\infty, h$ ). For wall #1, the time ( $t_1 = 100\text{s}$ ) required to reach a specified temperature at  $x = L$  is prescribed,  $T(L_1, t_1) = 315^\circ\text{C}$ .

**FIND:** For wall #2 of different thickness and thermal conditions, the time,  $t_2$ , required for  $T(L_2, t_2) = 28^\circ\text{C}$ .

**SCHEMATIC:**

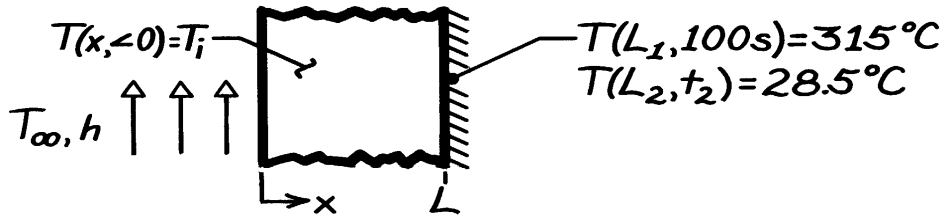

**ASSUMPTIONS:** (1) One-dimensional conduction, (2) Constant properties.

**ANALYSIS:** The properties, thickness and thermal conditions for the two walls are:

Wall	L(m)	$\alpha(\text{m}^2/\text{s})$	k(W/m·K)	$T_i(^\circ\text{C})$	$T_\infty(^\circ\text{C})$	$h(\text{W}/\text{m}^2\cdot\text{K})$
1	0.10	$15 \times 10^{-6}$	50	300	400	200
2	0.40	$25 \times 10^{-6}$	100	30	20	100

The dimensionless functional dependence for the one-dimensional, transient temperature distribution, Eq. 5.38, is

$$\theta^* = \frac{T(x,t) - T_\infty}{T_i - T_\infty} = f(x^*, \text{Bi}, \text{Fo})$$

where

$$x^* = x/L \quad \text{Bi} = hL/k \quad \text{Fo} = \alpha t/L^2.$$

If the parameters  $x^*$ , Bi, and Fo are the same for both walls, then  $\theta_1^* = \theta_2^*$ . Evaluate these parameters:

Wall	$x^*$	Bi	Fo	$\theta^*$
1	1	0.40	0.150	0.85
2	1	0.40	$1.563 \times 10^{-4} t_2$	0.85

where

$$\theta_1^* = \frac{315 - 400}{300 - 400} = 0.85 \quad \theta_2^* = \frac{28.5 - 20}{30 - 20} = 0.85.$$

It follows that

$$\text{Fo}_2 = \text{Fo}_1 \quad 1.563 \times 10^{-4} t_2 = 0.150$$

$$t_2 = 960\text{s}.$$

<

### PROBLEM 5.45

**KNOWN:** Stack or book comprised of 11 metal plates (p) and 10 boards (b) each of 2.36 mm thickness and prescribed thermophysical properties.

**FIND:** Effective thermal conductivity,  $k$ , and effective thermal capacitance,  $(\rho c_p)$ .

**SCHEMATIC:**

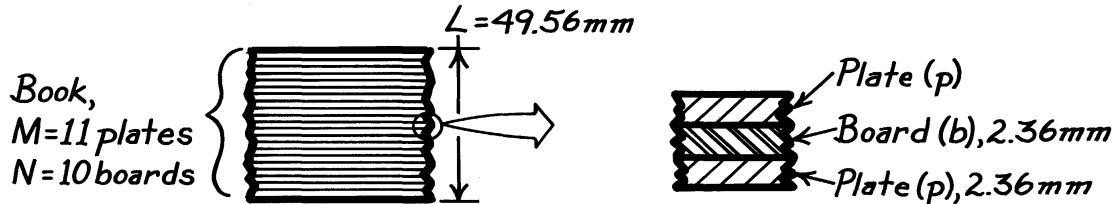

**ASSUMPTIONS:** (1) One-dimensional conduction, (2) Negligible contact resistance between plates and boards.

**PROPERTIES:** Metal plate (p, given):  $\rho_p = 8000 \text{ kg/m}^3$ ,  $c_{p,p} = 480 \text{ J/kg}\cdot\text{K}$ ,  $k_p = 12 \text{ W/m}\cdot\text{K}$ ; Circuit boards (b, given):  $\rho_b = 1000 \text{ kg/m}^3$ ,  $c_{p,b} = 1500 \text{ J/kg}\cdot\text{K}$ ,  $k_b = 0.30 \text{ W/m}\cdot\text{K}$ .

**ANALYSIS:** The thermal resistance of the book is determined as the sum of the resistance of the boards and plates,

$$R''_{\text{tot}} = NR''_b + MR''_p$$

where  $M, N$  are the number of plates and boards in the book, respectively, and  $R''_i = L_i / k_i$  where  $L_i$  and  $k_i$  are the thickness and thermal conductivities, respectively.

$$\begin{aligned} R''_{\text{tot}} &= M(L_p / k_p) + N(L_b / k_b) \\ R''_{\text{tot}} &= 11(0.00236 \text{ m} / 12 \text{ W/m}\cdot\text{K}) + 10(0.00236 \text{ m} / 0.30 \text{ W/m}\cdot\text{K}) \\ R''_{\text{tot}} &= 2.163 \times 10^{-3} + 7.867 \times 10^{-2} = 8.083 \times 10^{-2} \text{ K/W}. \end{aligned}$$

The effective thermal conductivity of the book of thickness  $(10 + 11) 2.36 \text{ mm}$  is

$$k = L / R''_{\text{tot}} = \frac{0.04956 \text{ m}}{8.083 \times 10^{-2} \text{ K/W}} = 0.613 \text{ W/m}\cdot\text{K}. \quad <$$

The thermal capacitance of the stack is

$$\begin{aligned} C''_{\text{tot}} &= M(\rho_p L_p c_p) + N(\rho_b L_b c_b) \\ C''_{\text{tot}} &= 11(8000 \text{ kg/m}^3 \times 0.00236 \text{ m} \times 480 \text{ J/kg}\cdot\text{K}) + 10(1000 \text{ kg/m}^3 \times 0.00236 \text{ m} \times 1500 \text{ J/kg}\cdot\text{K}) \\ C''_{\text{tot}} &= 9.969 \times 10^4 + 3.540 \times 10^4 = 1.35 \times 10^5 \text{ J/m}^2 \cdot \text{K}. \end{aligned}$$

The effective thermal capacitance of the book is

$$(\rho c_p) = C''_{\text{tot}} / L = 1.351 \times 10^5 \text{ J/m}^2 \cdot \text{K} / 0.04956 \text{ m} = 2.726 \times 10^6 \text{ J/m}^3 \cdot \text{K}. \quad <$$

**COMMENTS:** The results of the analysis allow for representing the stack as a homogeneous medium with *effective* properties:  $k = 0.613 \text{ W/m}\cdot\text{K}$  and  $\alpha = (k/\rho c_p) = 2.249 \times 10^{-7} \text{ m}^2/\text{s}$ .

### PROBLEM 5.46

**KNOWN:** Stack of circuit board-pressing plates, initially at a uniform temperature, is subjected by upper/lower platens to a higher temperature.

**FIND:** (a) Elapsed time,  $t_e$ , required for the mid-plane to reach cure temperature when platens are suddenly changed to  $T_s = 190^\circ\text{C}$ , (b) Energy removal from the stack needed to return its temperature to  $T_i$ .

**SCHEMATIC:**

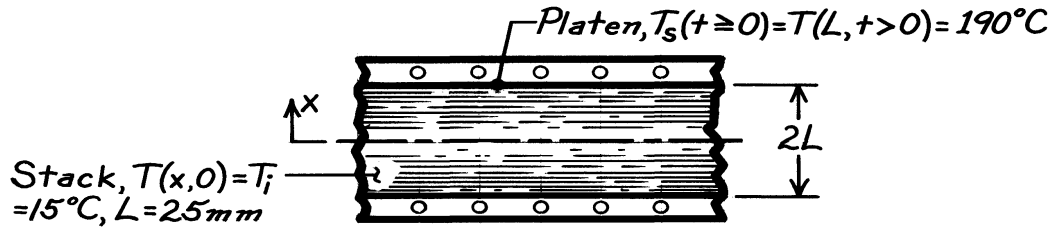

**PROPERTIES:** Stack (given):  $k = 0.613 \text{ W/m}\cdot\text{K}$ ,  $\rho c_p = 2.73 \times 10^6 \text{ J/m}^3 \cdot \text{K}$ ;  $\alpha = k/\rho c_p = 2.245 \times 10^{-7} \text{ m}^2/\text{s}$ .

**ANALYSIS:** (a) Recognize that sudden application of surface temperature corresponds to  $h \rightarrow \infty$ , or  $\text{Bi} \rightarrow \infty$ . With  $T_s = T_\infty$ ,

$$\theta_o^* = \frac{T(0,t) - T_s}{T_i - T_s} = \frac{(170 - 190)^\circ\text{C}}{(15 - 190)^\circ\text{C}} = 0.114.$$

Using Eq. 5.44 with values of  $\zeta_1 = 1.5707$  and  $C_1 = 1.2733$  for  $\text{Bi} \rightarrow \infty$  (Table 5.1), find  $\text{Fo}$

$$\theta_o^* = C_1 \exp(-\zeta_1^2 \text{Fo})$$

$$\text{Fo} = -\frac{1}{\zeta_1^2} \ln(\theta_o^*/C_1) = -\frac{1}{(1.5707)^2} \ln(0.114/1.2733) = 0.977$$

where  $\text{Fo} = \alpha t/L^2$ ,

$$t = \frac{\text{Fo}L^2}{\alpha} = \frac{0.977(25 \times 10^{-3} \text{ m})^2}{2.245 \times 10^{-7} \text{ m}^2/\text{s}} = 2.720 \times 10^3 \text{ s} = 45.3 \text{ min.} \quad <$$

(b) The energy removal is equivalent to the energy gained by the stack per unit area for the time interval  $0 \rightarrow t_e$ . With  $Q_o''$  corresponding to the maximum amount of energy that could be transferred,

$$Q_o'' = \rho c (2L)(T_i - T_\infty) = 2.73 \times 10^6 \text{ J/m}^3 \cdot \text{K} \left( 2 \times 25 \times 10^{-3} \text{ m} \right) (15 - 190) \text{ K} = -2.389 \times 10^7 \text{ J/m}^2.$$

$Q''$  may be determined from Eq. 5.49,

$$\frac{Q''}{Q_o''} = 1 - \frac{\sin \zeta_1}{\zeta_1} \theta_o^* = 1 - \frac{\sin(1.5707 \text{ rad})}{1.5707 \text{ rad}} \times 0.114 = 0.927$$

We conclude that the energy to be removed from the stack per unit area to return it to  $T_i$  is

$$Q'' = 0.927 Q_o'' = 0.927 \times 2.389 \times 10^7 \text{ J/m}^2 = 2.21 \times 10^7 \text{ J/m}^2. \quad <$$

### PROBLEM 5.47

**KNOWN:** One-dimensional convective heating of a plane slab with  $Bi = 1$  for a dimensionless time of  $Fo_1$ .

**FIND:** (a) Sketch of the dimensionless midplane and surface temperatures of the slab as a function of dimensionless time over the range  $0 < Fo_1 < Fo < \infty$ . Relative value of  $Fo_2$ , needed to achieve a steady-state midplane temperature equal to the midplane temperature at  $Fo_1$ . (b) Analytical expression for, and value of  $\Delta Fo = Fo_2 - Fo_1$  for  $Bi = 1$ ,  $Fo_1 > 0.2$ ,  $Fo_2 > 0.2$ . (c) Value of  $\Delta Fo$  for  $Bi = 0.01, 0.1, 10, 100$  and  $\infty$ .

**SCHEMATIC:**

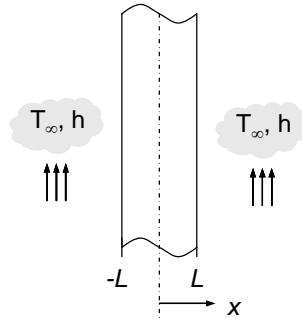

**ASSUMPTIONS:** (1) One-dimensional conduction, (2) Constant properties, (3) Approximate, one-term solutions are valid.

**ANALYSIS:** (a) A sketch of the dimensionless midplane and surface temperatures is shown below. Note that, at  $Fo_1$ , the surface of the slab will be warm (small  $\theta$ ) relative to the midplane since temperature gradients within the slab are significant ( $Bi = 1$ ). At the curtailment of heating ( $Fo_1$ ), the surface temperature cools rapidly while warm temperatures continue to propagate toward the midplane, slowly heating the midplane until a steady-state, isothermal condition is eventually reached.

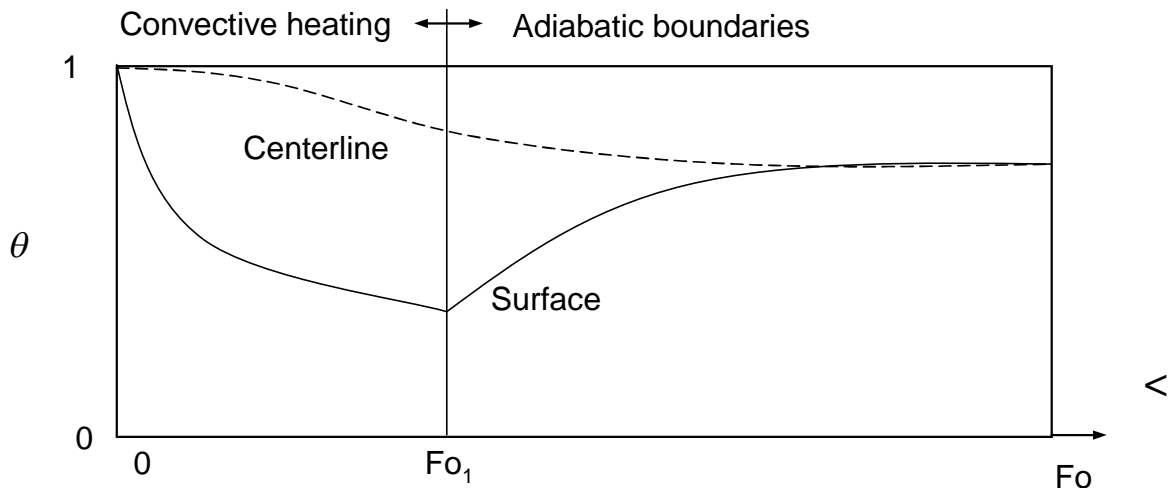

Based on the sketch above, one could achieve a steady-state midplane temperature equal to the midplane temperature at  $Fo_1$  by reducing the duration of convective heating to  $Fo_2$ , as shown in the sketch below.

Continued...



**PROBLEM 5.47 (Cont.)**

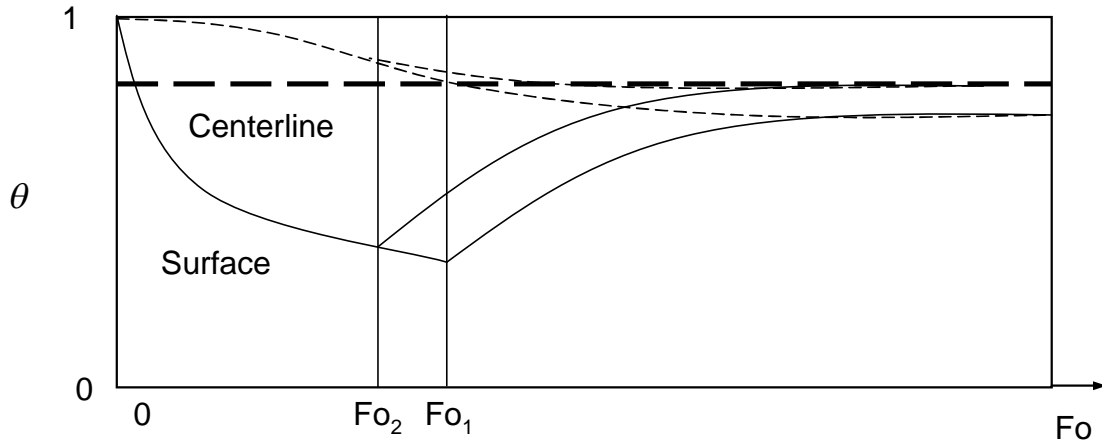

Hence,  $Fo_2 < Fo_1$ . <

(b) Using the approximate solutions of Section 5.5.2, and noting that the steady-state temperature of the slab is uniform and related to the energy transferred to the slab,

$$\theta_o^*(Fo_1) = 1 - \frac{Q}{Q_o}(Fo_2)$$

or,

$$1 - \theta_o^*(Fo_1) = \frac{Q}{Q_o}(Fo_1 + \Delta Fo_1) \quad (1)$$

Substituting Eqs. 5.44 and 5.49 into Eq. (1) yields

$$1 - C_1 \exp(-\zeta_1^2 Fo_1) = 1 - \frac{\sin \zeta_1}{\zeta_1} C_1 \exp[-\zeta_1^2 (Fo_1 + \Delta Fo)]$$

which may be simplified to

$$\Delta Fo = -\frac{1}{\zeta_1^2} \ln \left( \frac{\zeta_1}{\sin \zeta_1} \right) \quad <$$

From Table 5.1,  $\zeta_1 = 0.8603$  rad at  $Bi = 1$ . Hence,

$$\Delta Fo = -\frac{1}{0.8603^2} \ln \left( \frac{0.8603}{\sin 0.8603} \right) = -0.1709 \quad <$$

(c) The expression for  $\Delta Fo$  may be evaluated for a range of  $Bi$ , resulting in the following.

Continued...

**PROBLEM 5.47 (Cont.)**

$Bi$	$\zeta_1$	$\Delta Fo$
0.01	0.0998	-0.1667
0.1	0.3111	-0.1672
1	0.8603	-0.1709
10	1.4289	-0.1847
100	1.5552	-0.1826
$\infty$	1.5708	-0.1830

<

**COMMENTS:** (1) Note that the dimensionless temperature,  $\theta_o^* = C_1 \exp(-\zeta_1^2 Fo)$ , is defined in a manner such that for slab heating, increases in actual temperature correspond to decreases in the dimensionless temperature. (2) The dimensionless time lag,  $\Delta Fo$ , is weakly-dependent on the value of the Biot number and is independent of the heating time. Hence, a general rule-of-thumb is that a time lag of  $\Delta Fo \approx -0.17$  should be specified in order to achieve an ultimate midplane temperature equal to that predicted at  $Fo_1$  for convective heating or cooling. (3) For applications such as materials or food processing, where a certain minimum midplane temperature is desired, assuming that  $Fo_1$  (as determined by Eq. 5.44) is the appropriate processing or cooking time can result in significant over-heating of the material or food, especially at small Fourier numbers. (4) Significant energy and time savings can be realized by reducing the processing or cooking time from  $Fo_1$  to  $Fo_2$ .

## PROBLEM 5.48

**KNOWN:** The chuck of a semiconductor processing tool, initially at a uniform temperature of  $T_i = 100^\circ\text{C}$ , is cooled on its top surface by supply air at  $20^\circ\text{C}$  with a convection coefficient of  $50 \text{ W/m}^2\cdot\text{K}$ .

**FIND:** (a) Time required for the lower surface to reach  $25^\circ\text{C}$ , and (b) Compute and plot the time-to-cool as a function of the convection coefficient for the range  $10 \leq h \leq 2000 \text{ W/m}^2\cdot\text{K}$ ; comment on the effectiveness of the head design as a method for cooling the chuck.

**SCHEMATIC:**

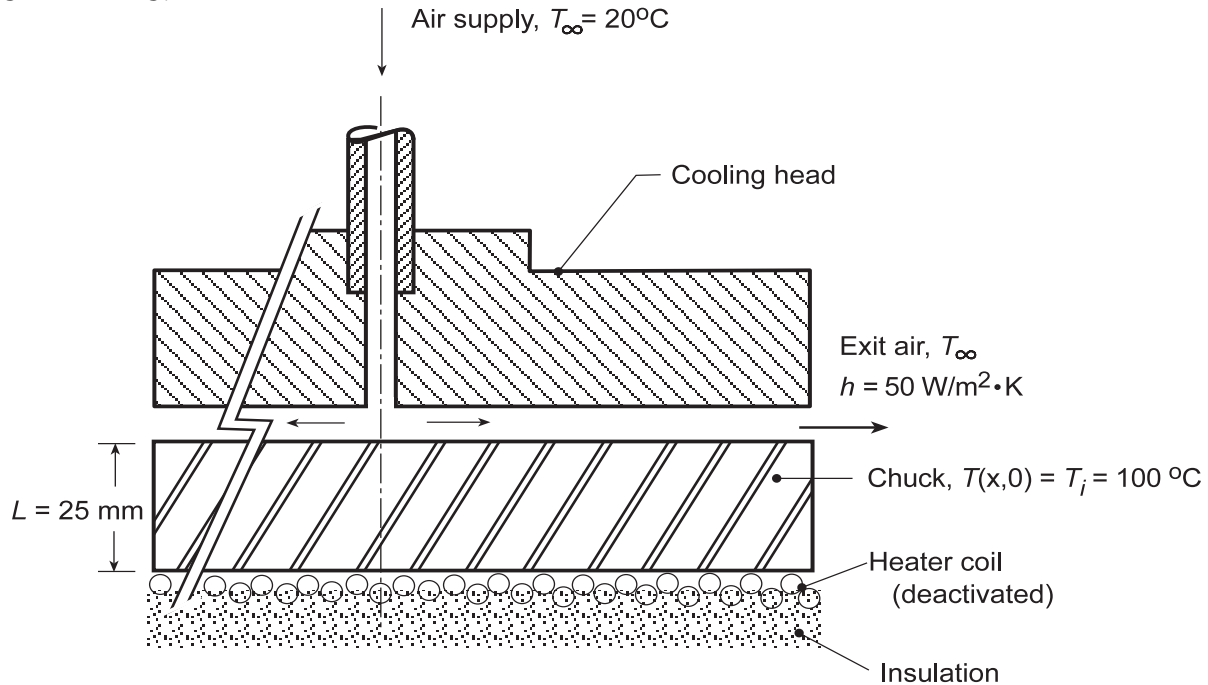

**ASSUMPTIONS:** (1) One-dimensional, transient conduction in the chuck, (2) Lower surface is perfectly insulated, (3) Uniform convection coefficient and air temperature over the upper surface of the chuck, and (4) Constant properties.

**PROPERTIES:** Table A.1, Aluminum alloy 2024 ( $(25 + 100)^\circ\text{C} / 2 = 335 \text{ K}$ ):  $\rho = 2770 \text{ kg/m}^3$ ,  $c_p = 880 \text{ J/kg}\cdot\text{K}$ ,  $k = 179 \text{ W/m}\cdot\text{K}$ .

**ANALYSIS:** (a) The Biot number for the chuck with  $h = 50 \text{ W/m}^2\cdot\text{K}$  is

$$\text{Bi} = \frac{hL}{k} = \frac{50 \text{ W/m}^2 \cdot \text{K} \times 0.025 \text{ m}}{179 \text{ W/m}\cdot\text{K}} = 0.007 \leq 0.1 \quad (1)$$

so that the lumped capacitance method is appropriate. Using Eq. 5.5, with  $V/A_s = L$ ,

$$t = \frac{\rho V c}{h A_s} \ln \frac{\theta_1}{\theta} \quad \theta = T - T_\infty \quad \theta_1 = T_i - T_\infty$$

$$t = \left( 2770 \text{ kg/m}^3 \times 0.025 \text{ m} \times 880 \text{ J/kg}\cdot\text{K} / 50 \text{ W/m}^2 \cdot \text{K} \right) \ln \frac{(100 - 20)^\circ\text{C}}{(25 - 20)^\circ\text{C}}$$

$$t = 3379 \text{ s} = 56.3 \text{ min}$$

<

Continued...

### PROBLEM 5.48 (Cont.)

(b) When  $h = 2000 \text{ W/m}^2\cdot\text{K}$ , using Eq. (1), find  $Bi = 0.28 > 0.1$  so that the series solution, Section 5.5.1, for the plane wall with convection must be used. Using the *IHT Transient Conduction, Plane Wall Model*, the time-to-cool was calculated as a function of the convection coefficient. Free convection cooling condition corresponds to  $h \approx 10 \text{ W/m}^2\cdot\text{K}$  and the time-to-cool is 282 minutes. With the cooling head design, the time-to-cool can be substantially decreased if the convection coefficient can be increased as shown below.

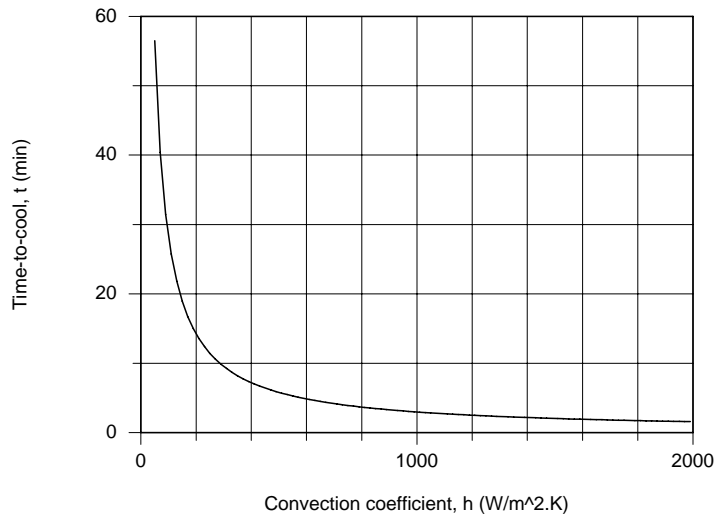

### PROBLEM 5.49

**KNOWN:** Thickness, properties and initial temperature of steel slab. Convection conditions.

**FIND:** Heating time required to achieve a minimum temperature of 550°C in the slab.

**SCHEMATIC:**

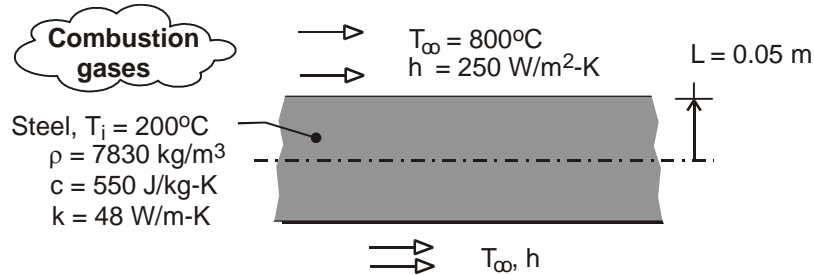

**ASSUMPTIONS:** (1) One-dimensional conduction, (2) Negligible radiation effects, (3) Constant properties.

**ANALYSIS:** With a Biot number of  $hL/k = (250 \text{ W/m}^2\cdot\text{K} \times 0.05\text{m})/48 \text{ W/m}\cdot\text{K} = 0.260$ , a lumped capacitance analysis should not be performed. At any time during heating, the lowest temperature in the slab is at the midplane, and from the one-term approximation to the transient thermal response of a plane wall, Eq. (5.44), we obtain

$$\theta_o^* = \frac{T_o - T_\infty}{T_i - T_\infty} = \frac{(550 - 800)^\circ\text{C}}{(200 - 800)^\circ\text{C}} = 0.417 = C_1 \exp(-\zeta_1^2 \text{Fo})$$

With  $\zeta_1 \approx 0.488 \text{ rad}$  and  $C_1 \approx 1.0396$  from Table 5.1 and  $\alpha = k/\rho c = 1.115 \times 10^{-5} \text{ m}^2/\text{s}$ ,

$$-\zeta_1^2 (\alpha t / L^2) = \ln(0.401) = -0.914$$

$$t = \frac{0.914 L^2}{\zeta_1^2 \alpha} = \frac{0.841 (0.05\text{m})^2}{(0.488)^2 1.115 \times 10^{-5} \text{ m}^2/\text{s}} = 861\text{s} \quad <$$

**COMMENTS:** The surface temperature at  $t = 861\text{s}$  may be obtained from Eq. (5.43b), where

$$\theta^* = \theta_o^* \cos(\zeta_1 x^*) = 0.417 \cos(0.488 \text{ rad}) = 0.368. \text{ Hence, } T(L, 792\text{s}) \equiv T_s = T_\infty + 0.368(T_i - T_\infty)$$

$= 800^\circ\text{C} - 221^\circ\text{C} = 579^\circ\text{C}$ . Assuming a surface emissivity of  $\epsilon = 1$  and surroundings that are at  $T_{\text{sur}} = T_\infty = 800^\circ\text{C}$ , the radiation heat transfer coefficient corresponding to this surface temperature is

$$h_r = \epsilon \sigma (T_s + T_{\text{sur}}) (T_s^2 + T_{\text{sur}}^2) = 205 \text{ W/m}^2 \cdot \text{K}. \text{ Since this value is comparable to the convection}$$

coefficient, radiation is not negligible and the desired heating will occur well before  $t = 861\text{s}$ .

### PROBLEM 5.50

**KNOWN:** Thickness and initial temperature of acrylic sheet.

**FIND:** Time needed to bring the external surface of the acrylic to its softening temperature.

**SCHEMATIC:**

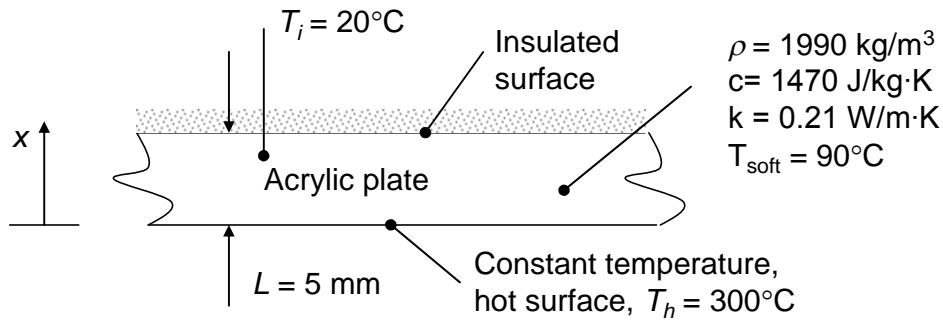

**ASSUMPTIONS:** (1) One-dimensional conduction, (2) Constant properties, (3) One-term approximate solution is valid.

**PROPERTIES:** Acrylic (given):  $\rho = 1990 \text{ kg/m}^3$ ,  $c = 1470 \text{ J/kg}\cdot\text{K}$  and  $k = 0.21 \text{ W/m}\cdot\text{K}$ .

**ANALYSIS:** For the constant temperature boundary condition, the Biot number is  $Bi \rightarrow \infty$ . Hence, from Table 5.1 for the plane wall,  $\zeta_1 = 1.5708$ ,  $C_1 = 1.2733$ . The dimensionless external surface temperature at the time of interest is

$$\theta_o^* = \frac{90^\circ\text{C} - 300^\circ\text{C}}{20^\circ\text{C} - 300^\circ\text{C}} = 0.75 = C_1 \exp(-\zeta_1^2 Fo) = 1.2733 \exp(-1.5708^2 Fo)$$

From which  $Fo = 0.214$ . Hence,

$$t = FoL^2/\alpha = FoL^2\rho c/k = [0.214 \times (0.005 \text{ m})^2 \times 1990 \text{ kg/m}^3 \times 1470 \text{ J/kg}\cdot\text{K}]/0.21 \text{ W/m}\cdot\text{K} = 74 \text{ s} <$$

**COMMENTS:** (1) Since  $Fo = 0.214$  is greater than 0.2, the one-term approximation is valid. (2) A contact resistance would be present at the interface between the acrylic and the substrate. However, as the acrylic softens and deforms locally to make better contact with the substrate, the thermal contact resistance would decrease in value.

### PROBLEM 5.51

**KNOWN:** Thickness, initial temperature and properties of furnace wall. Convection conditions at inner surface.

**FIND:** Time required for outer surface to reach a prescribed temperature. Corresponding temperature distribution in wall and at intermediate times.

**SCHEMATIC:**

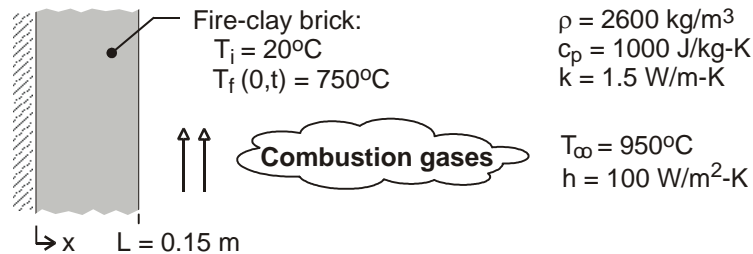

**ASSUMPTIONS:** (1) One-dimensional conduction in a plane wall, (2) Constant properties, (3) Adiabatic outer surface, (4)  $Fo > 0.2$ , (5) Negligible radiation from combustion gases.

**ANALYSIS:** The wall is equivalent to one-half of a wall of thickness  $2L$  with symmetric convection conditions at its two surfaces. With  $Bi = hL/k = 100 \text{ W/m}^2\cdot\text{K} \times 0.15\text{m}/1.5 \text{ W/m}\cdot\text{K} = 10$  and  $Fo > 0.2$ , the one-term approximation, Eq. 5.44 may be used to compute the desired time, where

$\theta_o^* = (T_o - T_\infty)/(T_i - T_\infty) = 0.215$ . From Table 5.1,  $C_1 = 1.262$  and  $\zeta_1 = 1.4289$ . Hence,

$$Fo = -\frac{\ln(\theta_o^*/C_1)}{\zeta_1^2} = -\frac{\ln(0.215/1.262)}{(1.4289)^2} = 0.867$$

$$t = \frac{Fo L^2}{\alpha} = \frac{0.867(0.15\text{m})^2}{(1.5 \text{ W/m}\cdot\text{K} / 2600 \text{ kg/m}^3 \times 1000 \text{ J/kg}\cdot\text{K})} = 33,800 \text{ s} \quad <$$

The corresponding temperature distribution, as well as distributions at  $t = 0, 10,000, \text{ and } 20,000 \text{ s}$  are plotted below

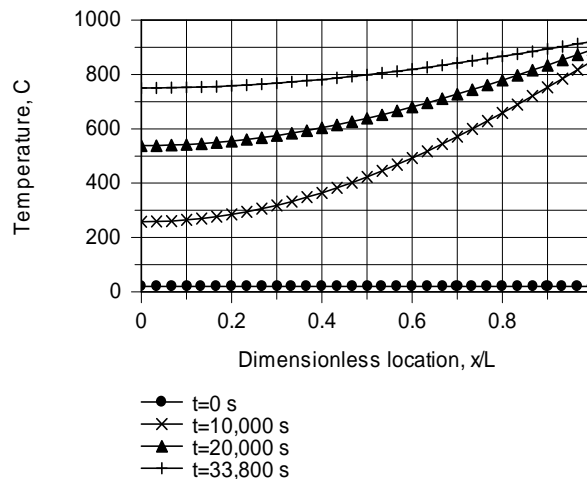

**COMMENTS:** Because  $Bi \gg 1$ , the temperature at the inner surface of the wall increases much more rapidly than at locations within the wall, where temperature gradients are large. The temperature gradients decrease as the wall approaches a steady-state for which there is a uniform temperature of  $950^\circ\text{C}$ .

### PROBLEM 5.52

**KNOWN:** Thickness, initial temperature and properties of steel plate. Convection conditions at both surfaces.

**FIND:** Time required to achieve a minimum temperature.

**SCHEMATIC:**

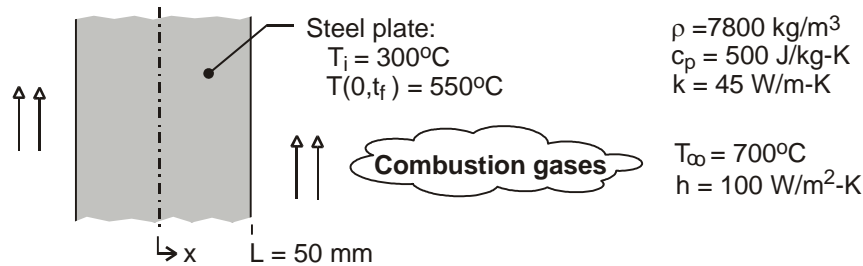

**ASSUMPTIONS:** (1) One-dimensional conduction in plate, (2) Symmetric heating on both sides, (3) Constant properties, (4) Negligible radiation from gases, (5)  $Fo > 0.2$ .

**ANALYSIS:** The smallest temperature exists at the midplane and, with  $Bi = hL/k = 500 \text{ W/m}^2\cdot\text{K} \times 0.050\text{m}/45 \text{ W/m}\cdot\text{K} = 0.556$  and  $Fo > 0.2$ , may be determined from the one-term approximation of Eq. 5.41. From Table 5.1,  $C_1 = 1.076$  and  $\zeta_1 = 0.682$ . Hence, with  $\theta_o^* = (T_o - T_\infty)/(T_i - T_\infty) = 0.375$ ,

$$Fo = -\frac{\ln(\theta_o^*/C_1)}{\zeta_1^2} = -\frac{\ln(0.375/1.076)}{(0.682)^2} = 2.266$$

$$t = \frac{Fo L^2}{\alpha} = \frac{2.266(0.05\text{m})^2}{(45 \text{ W/m}\cdot\text{K}/7800 \text{ kg/m}^3 \times 500 \text{ J/kg}\cdot\text{K})} = 491 \text{ s} \quad <$$

**COMMENTS:** From Eq. 5.43b, the corresponding surface temperature is

$$T_s = T_\infty + (T_i - T_\infty)\theta_o^* \cos(\zeta_1) = 700^\circ\text{C} - 400^\circ\text{C} \times 0.375 \times 0.776 = 584^\circ\text{C}$$

Because  $Bi$  is not much larger than 0.1, temperature gradients in the steel are moderate.



### PROBLEM 5.53

**KNOWN:** Initial temperature of concrete slabs. Air temperature and convection heat transfer coefficient.

**FIND:** Slab thickness required so that  $Q/Q_o = 0.90$  for  $t = 8$  h.

**SCHEMATIC:**

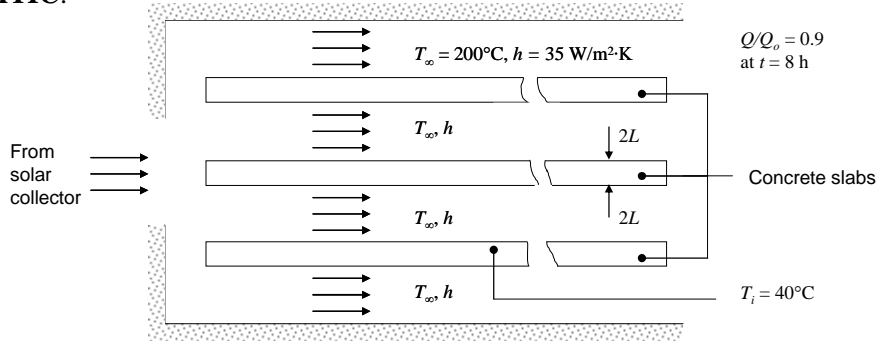

**ASSUMPTIONS:** (1) Properties at 300 K are satisfactory at higher temperature, (2) One-dimensional conduction, (3) Constant convection heat transfer coefficient, (4) Negligible radiation because each concrete slab is surrounded by others at the same temperature.

**PROPERTIES:** Table A.3, Concrete (stone mix) ( $T = 300$  K):  $\rho = 2300$  kg/m<sup>3</sup>,  $c = 880$  J/kg·K,  $k = 1.4$  W/m·K.

**ANALYSIS:** Without knowing the thickness, we cannot determine in advance whether the lumped capacitance approximation is valid. Considering the small thermal conductivity of concrete, we might anticipate that the Biot number will not be small. Considering the long time period, we may anticipate that the Fourier number is large. Therefore, we will begin by using the first-term approximation of the series solution and check its validity later. From Equation 5.49

$$\frac{Q}{Q_o} = 1 - \frac{\sin \zeta_1}{\zeta_1} \theta_o^* = 0.9 \quad (1)$$

where from Equation 5.44

$$\theta_o^* = C_1 \exp(-\zeta_1^2 Fo) \quad (2)$$

In these equations,  $C_1$  and  $\zeta_1$  are functions of  $Bi$ :

$$\zeta_1 \tan \zeta_1 = Bi, \quad C_1 = \frac{4 \sin \zeta_1}{2\zeta_1 + \sin(2\zeta_1)} \quad (3,4)$$

where  $\zeta_1$  is the smallest root of Equation (3). Both  $Bi$  and  $Fo$  are unknown because  $L$  is unknown. They are given by

$$Bi = \frac{hL}{k}, \quad Fo = \frac{\alpha t}{L^2} \quad (5,6)$$

Continued...

### PROBLEM 5.53 (Cont.)

where  $\alpha = k/\rho c = 6.92 \times 10^{-7} \text{ W/m}^2\cdot\text{K}$ . These six simultaneous equations can be solved iteratively. One approach is to guess a value for  $\zeta_1$ , from which  $C_1$  can be calculated from Equation (4). Equation (1) can be used to find the required value of  $\theta_o^*$ . Then Equation (2) can be used to determine  $Fo$  and a new value of  $L$  can be determined from Equation (6). Finally,  $Bi$  can be calculated from Equation (5) and a new value of  $\zeta_1$  can be found from Equation (3). Beginning this approach with a guessed value of  $\zeta_1 = 1$ , the iterations proceed as follows:

Guess:  $\zeta_1 = 1$   
Equation (4):  $C_1 = 1.16$   
Equation (1):  $\theta_o^* = 0.119$   
Equation (2):  $Fo = 2.28$   
Equation (6):  $L = 0.0936 \text{ m}$   
Equation (5):  $Bi = 2.34$   
Equation (3):  $\zeta_1 = 1.1231$

Repeating with the new value of  $\zeta_1$  and iterating until  $L$  converges to two significant digits, we find

$$L = 0.11 \text{ m} \quad \leftarrow$$

with  $Bi = 2.7$ ,  $Fo = 1.7$ . Thus the lumped capacitance approximation is not appropriate, and the first-term approximation is valid.

**COMMENTS:** This hand-solution is time-consuming, especially since Equation (3) must itself be solved iteratively. A much faster approach would be to solve these six equations simultaneously using IHT or other software.

### PROBLEM 5.54

**KNOWN:** Plate of thickness  $2L = 25 \text{ mm}$  at a uniform temperature of  $600^\circ\text{C}$  is removed from a hot pressing operation. Case 1, cooled on both sides; case 2, cooled on one side only.

**FIND:** (a) Calculate and plot on one graph the temperature histories for cases 1 and 2 for a 500-second cooling period; use the *IHT* software; Compare times required for the maximum temperature in the plate to reach  $100^\circ\text{C}$ ; and (b) For both cases, calculate and plot on one graph, the variation with time of the maximum temperature difference in the plate; Comment on the relative magnitudes of the temperature gradients within the plate as a function of time.

**SCHEMATIC:**

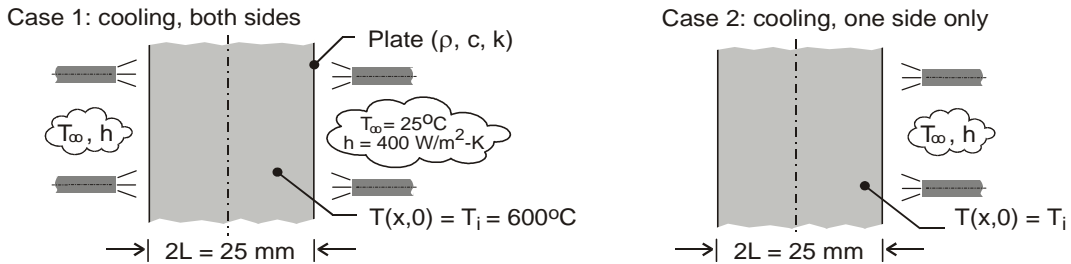

**ASSUMPTIONS:** (1) One-dimensional conduction in the plate, (2) Constant properties, and (3) For case 2, with cooling on one side only, the other side is adiabatic.

**PROPERTIES:** Plate (*given*):  $\rho = 3000 \text{ kg/m}^3$ ,  $c = 750 \text{ J/kg}\cdot\text{K}$ ,  $k = 15 \text{ W/m}\cdot\text{K}$ .

**ANALYSIS:** (a) From *IHT*, call up *Plane Wall, Transient Conduction* from the *Models* menu. For case 1, the plate thickness is 25 mm; for case 2, the plate thickness is 50 mm. The plate center ( $x = 0$ ) temperature histories are shown in the graph below. The times required for the center temperatures to reach  $100^\circ\text{C}$  are

$$t_1 = 164 \text{ s} \qquad t_2 = 367 \text{ s} \qquad <$$

(b) The plot of  $T(0, t) - T(L, t)$ , which represents the maximum temperature difference in the plate during the cooling process, is shown below.

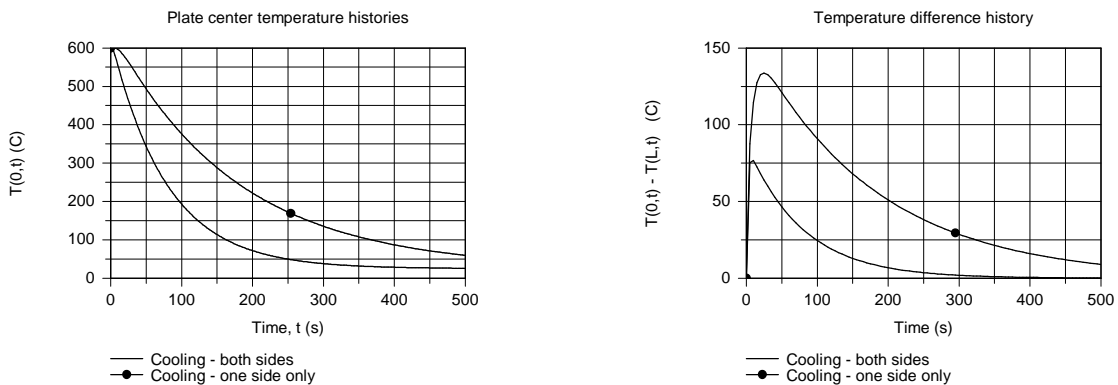

**COMMENTS:** (1) From the plate center-temperature history graph, note that it takes more than twice as long for the maximum temperature to reach  $100^\circ\text{C}$  with cooling on only one side.

(2) From the maximum temperature-difference graph, as expected, cooling from one side creates a larger maximum temperature difference during the cooling process. The effect could cause microstructure differences, which could adversely affect the mechanical properties within the plate.

## PROBLEM 5.55

**KNOWN:** Properties and thickness  $L$  of ceramic coating on rocket nozzle wall. Convection conditions. Initial temperature and maximum allowable wall temperature.

**FIND:** (a) Maximum allowable engine operating time,  $t_{\max}$ , for  $L = 10$  mm, (b) Coating inner and outer surface temperature histories for  $L = 10$  and 40 mm.

**SCHEMATIC:**

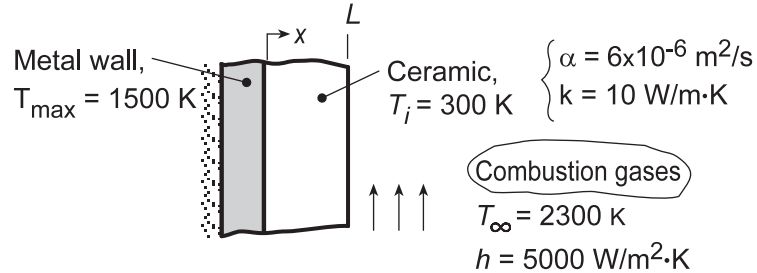

**ASSUMPTIONS:** (1) One-dimensional conduction in a plane wall, (2) Constant properties, (3) Negligible thermal capacitance of metal wall and heat loss through back surface, (4) Negligible contact resistance at wall/ceramic interface, (5) Negligible radiation.

**ANALYSIS:** (a) Subject to assumptions (3) and (4), the maximum wall temperature corresponds to the ceramic temperature at  $x = 0$ . Hence, for the ceramic, we wish to determine the time  $t_{\max}$  at which  $T(0,t) = T_o(t) = 1500$  K. With  $Bi = hL/k = 5000 \text{ W/m}^2\cdot\text{K}(0.01 \text{ m})/10 \text{ W/m}\cdot\text{K} = 5$ , the lumped capacitance method cannot be used. Assuming  $Fo > 0.2$ , obtaining  $\zeta_1 = 1.3138$  and  $C_1 = 1.2402$  from Table 5.1, and evaluating  $\theta_o^* = (T_o - T_\infty)/(T_i - T_\infty) = 0.4$ , Equation 5.44 yields

$$Fo = -\frac{\ln(\theta_o^*/C_1)}{\zeta_1^2} = -\frac{\ln(0.4/1.2402)}{(1.3138)^2} = 0.656$$

confirming the assumption of  $Fo > 0.2$ . Hence,

$$t_{\max} = \frac{Fo(L^2)}{\alpha} = \frac{0.656(0.01\text{m})^2}{6 \times 10^{-6} \text{ m}^2/\text{s}} = 10.9\text{s}$$

(b) Using the IHT *Lumped Capacitance Model for a Plane Wall*, the inner and outer surface temperature histories were computed and are as follows:

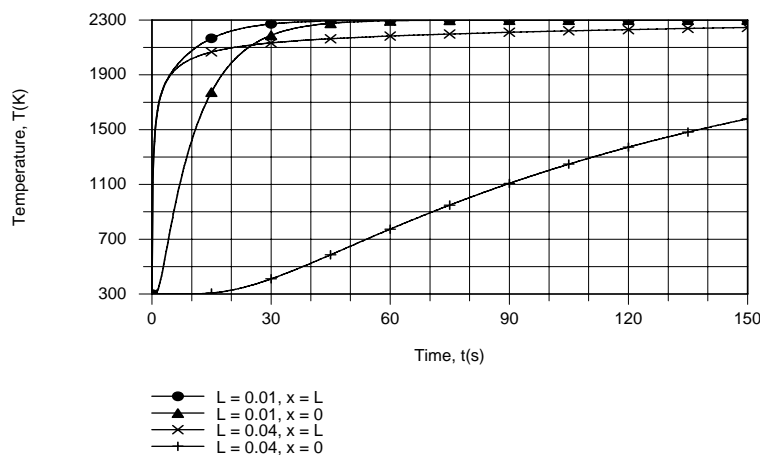

Continued...

### PROBLEM 5.55 (Cont.)

The increase in the inner ( $x = 0$ ) surface temperature lags that of the outer surface, but within  $t \approx 45$ s both temperatures are within a few degrees of the gas temperature for  $L = 0.01$  m. For  $L = 0.04$  m, the increased thermal capacitance of the ceramic slows the approach to steady-state conditions. The thermal response of the inner surface significantly lags that of the outer surface, and it is not until  $t \approx 137$ s that the inner surface reaches 1500 K. At this time there is still a significant temperature difference across the ceramic, with  $T(L, t_{\max}) = 2240$  K.

**COMMENTS:** The allowable engine operating time increases with increasing thermal capacitance of the ceramic and hence with increasing  $L$ .

## PROBLEM 5.56

**KNOWN:** Thickness and initial temperatures of two plates of the same material.

**FIND:** (a) Steady-state dimensionless temperatures of the two plates,  $T_{ss,1}^*$  and  $T_{ss,2}^*$ , as well as the interface temperature,  $T_{int}^*$ , (b) Expression for the effective dimensionless overall heat transfer coefficient for the two-plate system,  $U_{eff,2}^* \equiv q^* / (\bar{T}_2^* - \bar{T}_1^*)$  for  $Fo > 0.2$ .

**SCHEMATIC:**

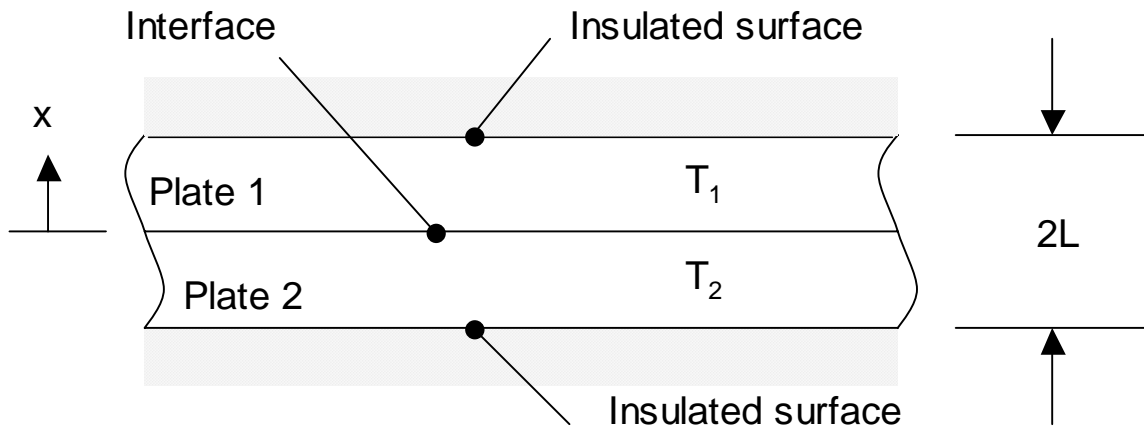

**ASSUMPTIONS:** (1) One-dimensional conduction, (2) Constant properties, (3) Negligible thermal contact resistance.

**ANALYSIS:** (a) Since the two plates are of the same thickness and have the same properties, both plates will reach a steady-state temperature that is the average of  $T_1$  and  $T_2$ . In terms of the dimensionless temperature,  $T^*(Fo) \equiv (T - T_1)/(T_2 - T_1)$ , this implies that  $T_{ss,1}^* = T_{ss,2}^* = 0.5$ . <

Accounting for the symmetry about  $x = 0$ , the dimensionless interface temperature will be  $T_{int}^* = 0.5$  at any time. <

(b) Taking advantage of the geometrical symmetry about  $x = 0$ , we may simplify the problem by analyzing just one of the plates, accounting for one adiabatic surface and a second surface being held at a constant temperature. For the constant temperature boundary condition,  $Bi = hL/k \rightarrow \infty$  and from Table 5.1  $\zeta_1 = \pi/2$ ,  $C_1 = 1.2733$ . Equations 5.44 and 5.49 may be combined to yield

$$\frac{Q}{Q_o} = 1 - \frac{\sin \zeta_1}{\zeta_1} C_1 \exp(-\zeta_1^2 Fo) \quad (1)$$

The spatially-averaged dimensionless temperature for one plate is

Continued...

**PROBLEM 5.56 (Cont.)**

$$\overline{\theta^*} = \frac{1}{V} \int \frac{T(x,t) - T_{\text{int}}}{T_i - T_{\text{int}}} dV$$

where  $T_{\text{int}}$  is the interface temperature. From Eq. 5.46b,  $\overline{\theta^*} = 1 - Q/Q_o$ . (2)

From Eq. (1),

$$\frac{d(Q/Q_o)}{dFo} = q^* = 2C_1 (\sin \zeta_1) \exp(-\zeta_1^2 Fo)$$

and from Eq. (2)

$$\overline{\theta^*} = \frac{C_1 \sin \zeta_1}{\zeta_1} \exp(-\zeta_1^2 Fo)$$

Therefore, for one plate,  $U_{\text{eff},1}^* = \frac{d(Q/Q_o)}{dFo} / \overline{\theta^*} = 2\zeta_1 = \pi$

The dimensionless temperature difference for the two-plate system is  $T_2^* - T_1^* = 2\overline{\theta^*}$ .

Hence, for the two-plate system,  $U_{\text{eff}}^* = U_{\text{eff},2}^*/2 = U_{\text{eff},1}^*/2 = \pi/2$ . <

**COMMENTS:** (1) For this case, the heat transfer rate between the two plates is proportional to the difference in the average temperatures of the plates. If  $Fo < 0.2$ , it may be shown that  $U_{\text{eff}}^*$  is initially infinite and decreases with time. This behavior becomes evident if one considers the situation immediately after the plates make contact when the heat transfer between the plates is very large, but the average plate temperatures have not been affected significantly by the heat transfer in the vicinity of the interface. (2) A proportionality between the dimensionless heat transfer rate and the difference in the average dimensionless plate temperatures also exists at large  $Fo$ , even if the plates are not identical.

### PROBLEM 5.57

**KNOWN:** Initial temperature, thickness and thermal diffusivity of glass plate. Prescribed surface temperature.

**FIND:** (a) Time to achieve 50% reduction in midplane temperature, (b) Maximum temperature gradient at that time.

**SCHEMATIC:**

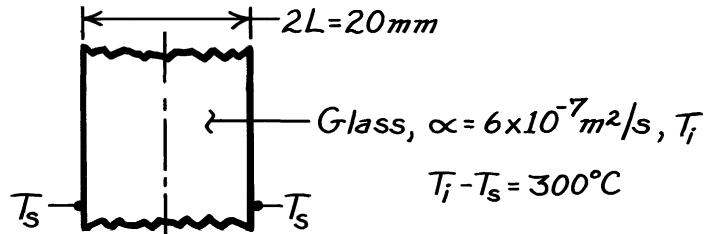

**ASSUMPTIONS:** (1) One-dimensional conduction, (2) Constant properties.

**ANALYSIS:** Prescribed surface temperature is analogous to  $h \rightarrow \infty$  and  $T_\infty = T_s$ . Hence,  $Bi = \infty$ . Assume validity of one-term approximation to series solution for  $T(x,t)$ .

(a) At the midplane,

$$\theta_o^* = \frac{T_o - T_s}{T_i - T_s} = 0.50 = C_1 \exp(-\zeta_1^2 Fo)$$

$$\zeta_1 \tan \zeta_1 = Bi = \infty \rightarrow \zeta_1 = \pi/2.$$

Hence

$$C_1 = \frac{4 \sin \zeta_1}{2\zeta_1 + \sin(2\zeta_1)} = \frac{4}{\pi} = 1.273$$

$$Fo = -\frac{\ln(\theta_o^*/C_1)}{\zeta_1^2} = 0.379$$

$$t = \frac{FoL^2}{\alpha} = \frac{0.379(0.01 \text{ m})^2}{6 \times 10^{-7} \text{ m}^2/\text{s}} = 63 \text{ s.} \quad <$$

(b) With  $\theta^* = C_1 \exp(-\zeta_1^2 Fo) \cos \zeta_1 x^*$

$$\frac{\partial T}{\partial x} = \frac{(T_i - T_s)}{L} \frac{\partial \theta^*}{\partial x^*} = -\frac{(T_i - T_s)}{L} \zeta_1 C_1 \exp(-\zeta_1^2 Fo) \sin \zeta_1 x^*$$

$$\left. \frac{\partial T}{\partial x} \right|_{\max} = \left. \frac{\partial T}{\partial x} \right|_{x^*=1} = -\frac{300^\circ\text{C}}{0.01 \text{ m}} \frac{\pi}{2} 0.5 = -2.36 \times 10^4 \text{ }^\circ\text{C/m.} \quad <$$

**COMMENTS:** Validity of one-term approximation is confirmed by  $Fo > 0.2$ .



## PROBLEM 5.58

**KNOWN:** Thickness and properties of rubber tire. Convection heating conditions. Initial and final midplane temperature.

**FIND:** (a) Time to reach final midplane temperature. (b) Effect of accelerated heating.

**SCHEMATIC:**

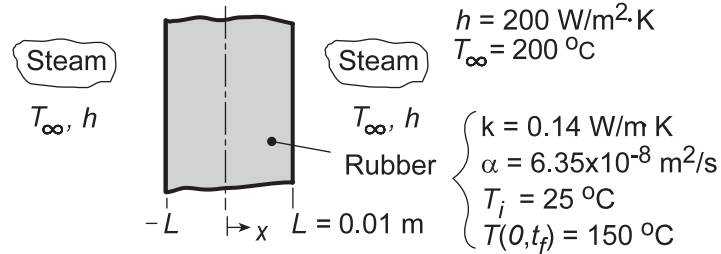

**ASSUMPTIONS:** (1) One-dimensional conduction in a plane wall, (2) Constant properties, (3) Negligible radiation.

**ANALYSIS:** (a) With  $Bi = hL/k = 200 \text{ W/m}^2 \cdot \text{K} (0.01 \text{ m}) / 0.14 \text{ W/m} \cdot \text{K} = 14.3$ , the lumped capacitance method is clearly inappropriate. Assuming  $Fo > 0.2$ , Eq. (5.44) may be used with  $C_1 = 1.265$  and  $\zeta_1 \approx 1.458$  rad from Table 5.1 to obtain

$$\theta_o^* = \frac{T_o - T_\infty}{T_i - T_\infty} = C_1 \exp\left(-\zeta_1^2 Fo\right) = 1.265 \exp(-2.126 Fo)$$

With  $\theta_o^* = (T_o - T_\infty) / (T_i - T_\infty) = (-50) / (-175) = 0.286$ ,  $Fo = -\ln(0.286 / 1.265) / 2.126 = 0.70 = \alpha t_f / L^2$

$$t_f = \frac{0.7(0.01 \text{ m})^2}{6.35 \times 10^{-8} \text{ m}^2/\text{s}} = 1100 \text{ s}$$

<

(b) The desired temperature histories were generated using the IHT *Transient Conduction Model* for a *Plane Wall*, with  $h = 5 \times 10^4 \text{ W/m}^2 \cdot \text{K}$  used to approximate imposition of a surface temperature of  $200^\circ\text{C}$ .

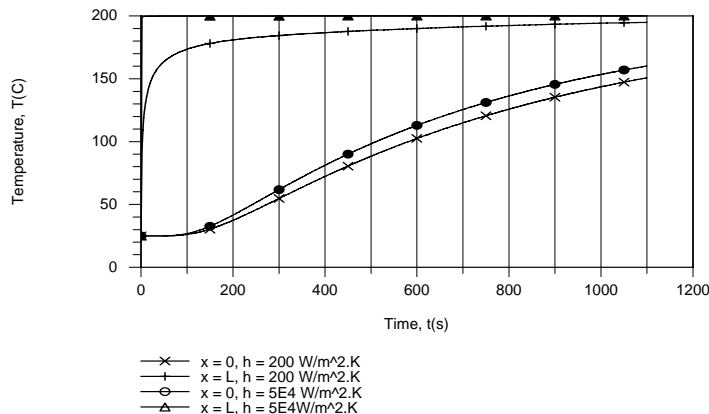

The fact that imposition of a constant surface temperature ( $h \rightarrow \infty$ ) does not significantly accelerate the heating process should not be surprising. For  $h = 200 \text{ W/m}^2 \cdot \text{K}$ , the Biot number is already quite large ( $Bi = 14.3$ ), and limits to the heating rate are principally due to conduction in the rubber and not to convection at the surface. Any increase in  $h$  only serves to reduce what is already a small component of the total thermal resistance.

**COMMENTS:** The heating rate could be accelerated by increasing the steam temperature, but an upper limit would be associated with avoiding thermal damage to the rubber.

### PROBLEM 5.59

**KNOWN:** Thickness, initial temperature and properties of plastic coating. Safe-to-touch temperature. Convection coefficient and air temperature.

**FIND:** Time for surface to reach safe-to-touch temperature. Corresponding temperature at plastic/wood interface.

**SCHEMATIC:**

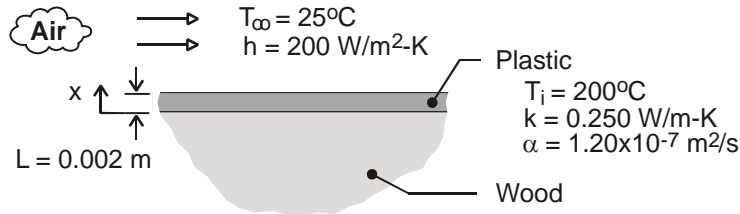

**ASSUMPTIONS:** (1) One-dimensional conduction in coating, (2) Negligible radiation, (3) Constant properties, (4) Negligible heat of reaction, (5) Negligible heat transfer across plastic/wood interface.

**ANALYSIS:** With  $Bi = hL/k = 200 \text{ W/m}^2 \cdot \text{K} \times 0.002\text{m}/0.25 \text{ W/m} \cdot \text{K} = 1.6 > 0.1$ , the lumped capacitance method may not be used. Applying the approximate solution of Eq. 5.43a, with  $C_1 = 1.155$  and  $\zeta_1 = 0.990$  from Table 5.1,

$$\theta_s^* = \frac{T_s - T_\infty}{T_i - T_\infty} = \frac{(42 - 25)^\circ\text{C}}{(200 - 25)^\circ\text{C}} = 0.0971 = C_1 \exp(-\zeta_1^2 Fo) \cos(\zeta_1 x^*) = 1.155 \exp(-0.980 Fo) \cos(0.99)$$

Hence, for  $x^* = 1$ ,

$$Fo = -\ln\left(\frac{0.0971}{1.155 \cos(0.99)}\right) / (0.99)^2 = 1.914$$

$$t = \frac{Fo L^2}{\alpha} = \frac{1.914 (0.002\text{m})^2}{1.20 \times 10^{-7} \text{ m}^2 / \text{s}} = 63.8 \text{ s} \quad <$$

From Eq. 5.44, the corresponding interface temperature is

$$T_o = T_\infty + (T_i - T_\infty) \exp(-\zeta_1^2 Fo) = 25^\circ\text{C} + 175^\circ\text{C} \exp(-0.98 \times 1.914) = 51.8^\circ\text{C} \quad <$$

**COMMENTS:** By neglecting conduction into the wood and radiation from the surface, the cooling time is overpredicted and is therefore a conservative estimate. However, if energy generation due to solidification of polymer were significant, the cooling time would be longer.

## PROBLEM 5.60

**KNOWN:** Long rod with prescribed diameter and properties, initially at a uniform temperature, is heated in a forced convection furnace maintained at 750 K with a convection coefficient of  $h = 1000 \text{ W/m}^2\cdot\text{K}$ .

**FIND:** (a) The corresponding center temperature of the rod,  $T(0, t_0)$ , when the surface temperature  $T(r_0, t_0)$  is measured as 550 K, (b) Effect of  $h$  on centerline temperature history.

**SCHEMATIC:**

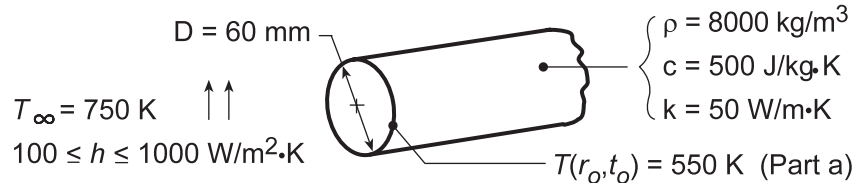

**ASSUMPTIONS:** (1) One-dimensional, radial conduction in rod, (2) Constant properties, (3) Rod, when initially placed in furnace, had a uniform (but unknown) temperature, (4)  $Fo \geq 0.2$ .

**ANALYSIS:** (a) Since the rod was initially at a uniform temperature and  $Fo \geq 0.2$ , the approximate solution for the infinite cylinder is appropriate. From Eq. 5.52b,

$$\theta^*(r^*, Fo) = \theta_o^*(Fo) J_0(\zeta_1 r^*) \quad (1)$$

where, for  $r^* = 1$ , the dimensionless temperatures are, from Eq. 5.34,

$$\theta^*(1, Fo) = \frac{T(r_0, t_0) - T_\infty}{T_i - T_\infty} \quad \theta_o^*(Fo) = \frac{T(0, t_0) - T_\infty}{T_i - T_\infty} \quad (2,3)$$

Combining Eqs. (2) and (3) with Eq. (1) and rearranging,

$$\begin{aligned} \frac{T(r_0, t_0) - T_\infty}{T_i - T_\infty} &= \frac{T(0, t_0) - T_\infty}{T_i - T_\infty} J_0(\zeta_1 \cdot 1) \\ T(0, t_0) &= T_\infty + \frac{1}{J_0(\zeta_1)} [T(r_0, t_0) - T_\infty] \end{aligned} \quad (4)$$

The eigenvalue,  $\zeta_1 = 1.0185 \text{ rad}$ , follows from Table 5.1 for the Biot number

$$Bi = \frac{hr_0}{k} = \frac{1000 \text{ W/m}^2 \cdot \text{K} (0.060 \text{ m}/2)}{50 \text{ W/m} \cdot \text{K}} = 0.60.$$

From Table B-4, with  $\zeta_1 = 1.0185 \text{ rad}$ ,  $J_0(1.0185) = 0.7568$ . Hence, from Eq. (4)

$$T(0, t_0) = 750 \text{ K} + \frac{1}{0.7568} [550 - 750] \text{ K} = 486 \text{ K} \quad <$$

(b) Using the IHT *Transient Conduction Model for a Cylinder*, the following temperature histories were generated.

Continued...

### PROBLEM 5.60 (Cont.)

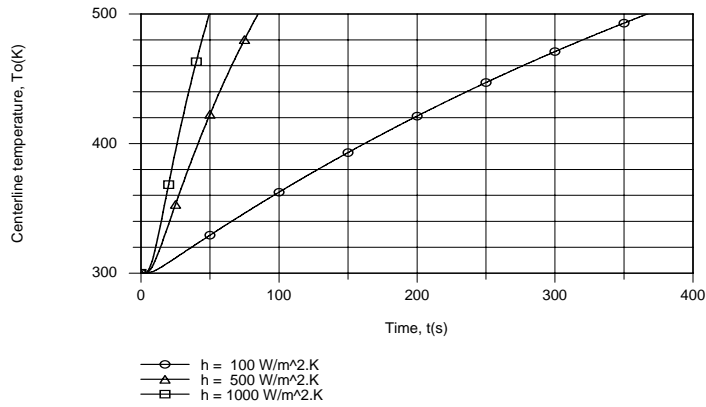

The times required to reach a centerline temperature of 500 K are 367, 85 and 51s, respectively, for  $h = 100, 500$  and  $1000 \text{ W/m}^2\cdot\text{K}$ . The corresponding values of the Biot number are 0.06, 0.30 and 0.60. Hence, even for  $h = 1000 \text{ W/m}^2\cdot\text{K}$ , the convection resistance is not negligible relative to the conduction resistance and significant reductions in the heating time could still be effected by increasing  $h$  to values considerably in excess of  $1000 \text{ W/m}^2\cdot\text{K}$ .

**COMMENTS:** For Part (a), recognize why it is not necessary to know  $T_i$  or the time  $t_0$ . We require that  $Fo \geq 0.2$ , which for this sphere corresponds to  $t \geq 14\text{s}$ . For this situation, the time dependence of the surface and center are the same.

## PROBLEM 5.61

**KNOWN:** A long cylinder, initially at a uniform temperature, is suddenly quenched in a large oil bath.

**FIND:** (a) Time required for the surface to reach 500 K, (b) Effect of convection coefficient on surface temperature history.

**SCHEMATIC:**

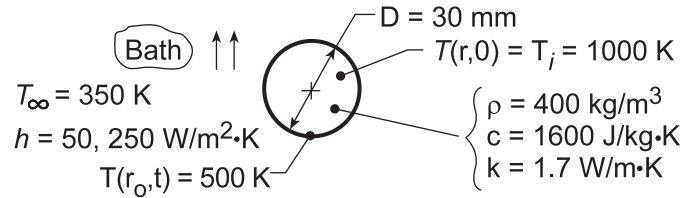

**ASSUMPTIONS:** (1) One-dimensional radial conduction, (2) Constant properties, (3)  $Fo > 0.2$ .

**ANALYSIS:** (a) Check first whether lumped capacitance method is applicable. For  $h = 50 \text{ W/m}^2\cdot\text{K}$ ,

$$Bi_c = \frac{hL_c}{k} = \frac{h(r_o/2)}{k} = \frac{50 \text{ W/m}^2 \cdot \text{K} (0.015 \text{ m}/2)}{1.7 \text{ W/m}\cdot\text{K}} = 0.221.$$

Since  $Bi_c > 0.1$ , method is not suited. Using the approximate series solution for the infinite cylinder,

$$\theta^*(r^*, Fo) = C_1 \exp(-\zeta_1^2 Fo) \times J_0(\zeta_1 r^*) \quad (1)$$

Solving for  $Fo$  and setting  $r^* = 1$ , find

$$Fo = -\frac{1}{\zeta_1^2} \ln \left[ \frac{\theta^*}{C_1 J_0(\zeta_1)} \right]$$

$$\text{where } \theta^* = (1, Fo) = \frac{T(r_o, t_o) - T_\infty}{T_i - T_\infty} = \frac{(500 - 350) \text{ K}}{(1000 - 350) \text{ K}} = 0.231.$$

From Table 5.1, with  $Bi = 0.441$ , find  $\zeta_1 = 0.8882 \text{ rad}$  and  $C_1 = 1.1019$ . From Table B.4, find  $J_0(\zeta_1) = 0.8121$ . Substituting numerical values into Eq. (2),

$$Fo = -\frac{1}{(0.8882)^2} \ln [0.231/1.1019 \times 0.8121] = 1.72.$$

From the definition of the Fourier number,  $Fo = \alpha t / r_o^2$ , and  $\alpha = k / \rho c$ ,

$$t = Fo \frac{r_o^2}{\alpha} = Fo \cdot r_o^2 \frac{\rho c}{k}$$

$$t = 1.72 (0.015 \text{ m})^2 \times 400 \text{ kg/m}^3 \times 1600 \text{ J/kg}\cdot\text{K} / 1.7 \text{ W/m}\cdot\text{K} = 145 \text{ s.} \quad \leftarrow$$

(b) Using the IHT *Transient Conduction Model for a Cylinder*, the following surface temperature histories were obtained.

Continued...

### PROBLEM 5.61 (Cont.)

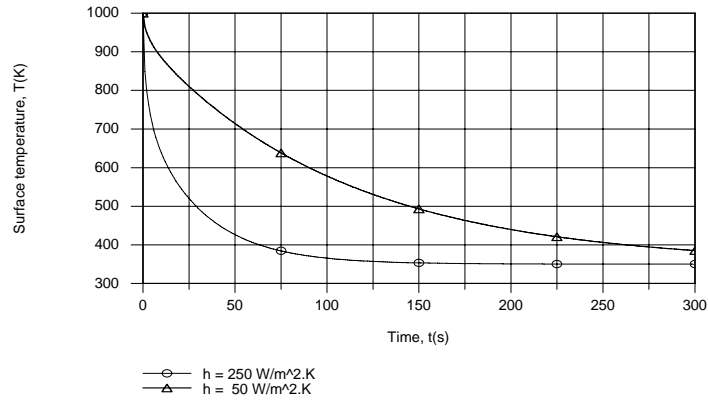

Increasing the convection coefficient by a factor of 5 has a significant effect on the surface temperature, greatly accelerating its approach to the oil temperature. However, even with  $h = 250 \text{ W/m}^2\cdot\text{K}$ ,  $Bi = 1.1$  and the convection resistance remains significant. Hence, in the interest of accelerated cooling, additional benefit could be achieved by further increasing the value of  $h$ .

**COMMENTS:** For Part (a), note that, since  $Fo = 1.72 > 0.2$ , the approximate series solution is appropriate.

### PROBLEM 5.62

**KNOWN:** One-dimensional convective heating of an  $L/r_o = 20$  cylinder with  $Bi = 1$  for a dimensionless time of  $Fo_1$ .

**FIND:** (a) Sketch of the dimensionless centerline and surface temperatures of the cylinder as a function of dimensionless time over the range  $0 < Fo_1 < Fo < \infty$ . Relative value of  $Fo_2$  needed to achieve a steady-state centerline temperature equal to the centerline temperature at  $Fo_1$ . (b) Analytical expression for, and value of  $\Delta Fo = Fo_2 - Fo_1$  for  $Bi = 1$ ,  $Fo_1 > 0.2$ ,  $Fo_2 > 0.2$ . (c) Value of  $\Delta Fo$  for  $Bi = 0.01, 0.1, 10, 100$  and  $\infty$ .

**SCHEMATIC:**

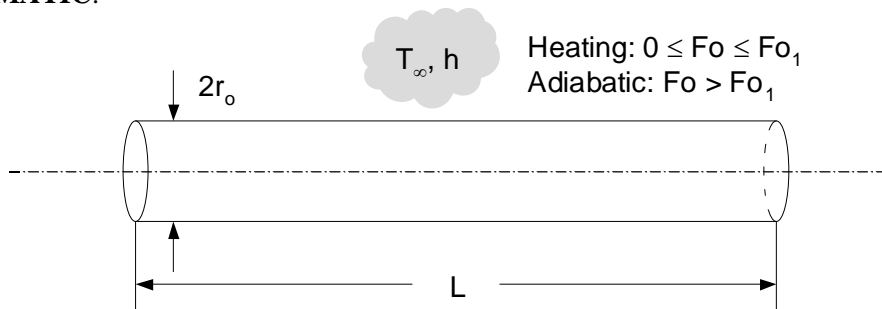

**ASSUMPTIONS:** (1) One-dimensional conduction, (2) Constant properties, (3) Approximate, one-term solutions are valid.

**ANALYSIS:** (a) A sketch of the dimensionless centerline and surface temperatures is shown below. Note that, at  $Fo_1$ , the surface of the cylinder will be warm (smaller  $\theta$ ) relative to the centerline since temperature gradients within the cylinder are significant ( $Bi = 1$ ). At the curtailment of heating ( $Fo_1$ ), the surface temperature cools rapidly while warm temperatures continue to propagate toward the centerline, slowly heating the centerline until a steady-state, isothermal condition is eventually reached.

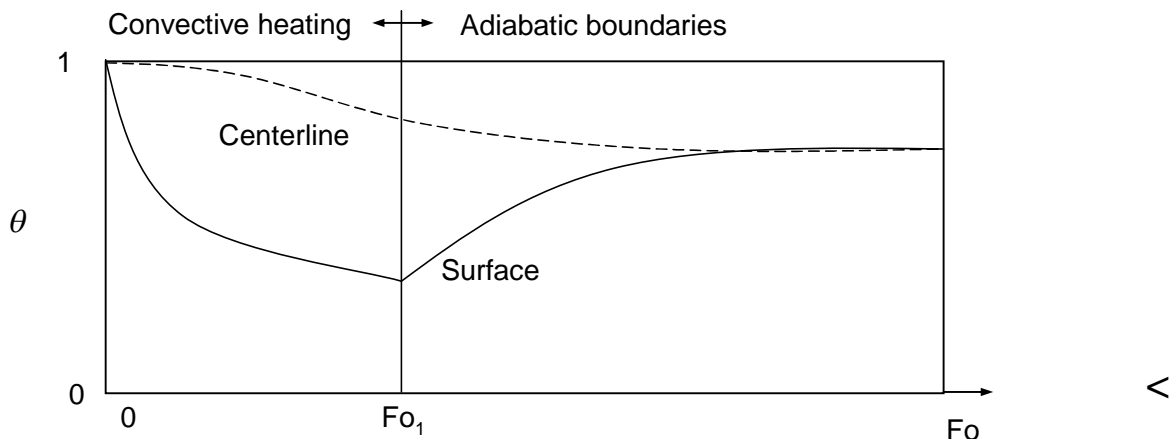

Based on the sketch above, one could achieve a steady-state centerline temperature equal to the centerline temperature at  $Fo_1$  by reducing the duration of convective heating to  $Fo_2$ , as shown in the sketch below.

Continued...

**PROBLEM 5.62 (Cont.)**

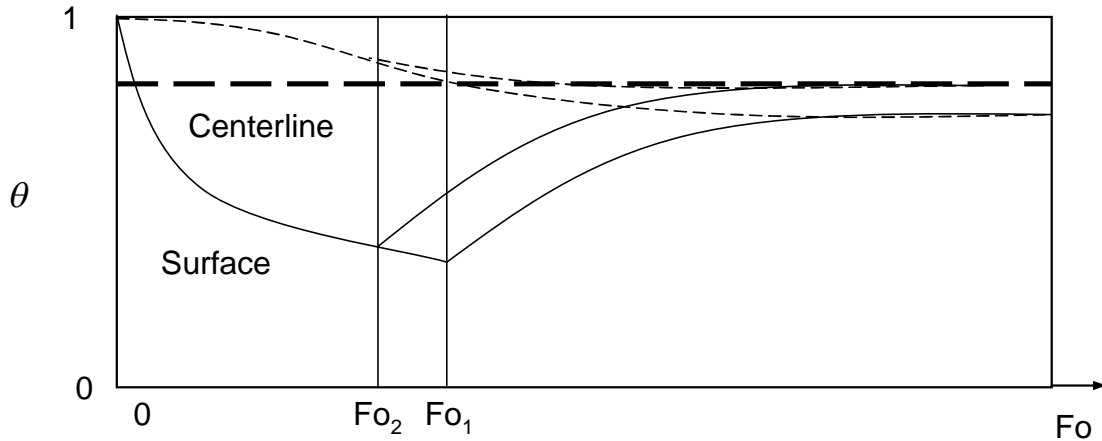

Hence,  $Fo_2 < Fo_1$ . <

(b) Using the approximate solutions of Sections 5.6.2 and 5.6.3, and noting that the steady-state temperature of the cylinder is uniform and related to the energy transferred to the cylinder,

$$\theta_o^*(Fo_1) = 1 - \frac{Q}{Q_o}(Fo_2)$$

or,

$$1 - \theta_o^*(Fo_1) = \frac{Q}{Q_o}(Fo_1 + \Delta Fo_1) \quad (1)$$

Substituting Eqs. 5.52c and 5.54 into Eq. (1) yields

$$1 - C_1 \exp(-\zeta_1^2 Fo_1) = 1 - \frac{2C_1 \exp(-\zeta_1^2 (Fo_1 + \Delta Fo))}{\zeta_1} J_1(\zeta_1)$$

which may be simplified to

$$\Delta Fo = -\frac{1}{\zeta_1^2} \ln\left(\frac{\zeta_1}{2J_1(\zeta_1)}\right) \quad <$$

From Table 5.1,  $\zeta_1 = 1.2558$  rad at  $Bi = 1$ , and from Table B.4,  $J_1(\zeta_1) = 0.512$ . Hence,

$$\Delta Fo = -\frac{1}{1.2558^2} \ln\left(\frac{1.2558}{2J_1(1.2558)}\right) = -\frac{1}{1.2558^2} \ln\left(\frac{1.2558}{2 \times 0.512}\right) = -0.1294 \quad <$$

(c) The expression for  $\Delta Fo$  may be evaluated for a range of  $Bi$ , resulting in the following.

Continued...



### PROBLEM 5.62 (Cont.)

$Bi$	$\zeta_1$	$\Delta Fo$
0.01	0.1412	-0.1250
0.1	0.4417	-0.1255
1	1.2558	-0.1294
10	2.1795	-0.1406
100	2.3809	-0.1447
$\infty$	2.4050	-0.1452

&lt;

**COMMENTS:** (1) Note that the dimensionless temperature,  $\theta_o^* = C_1 \exp(-\zeta_1^2 Fo)$ , is defined in a manner such that for cylinder heating, increases in actual temperature correspond to decreases in the dimensionless temperature. (2) The dimensionless time lag,  $\Delta Fo$ , is weakly-dependent on the value of the Biot number and is independent of the heating time. Hence, a general rule-of-thumb is that a time lag of  $\Delta Fo \approx -0.13$  should be specified in order to achieve an ultimate centerline temperature equal to that predicted at  $Fo_1$  for convective heating or cooling. (3) For applications such as materials or food processing, where a certain minimum centerline temperature is desired, assuming that  $Fo_1$  (as determined by Eq. 5.52c) is the appropriate processing or cooking time can result in significant over-heating of the material or food, especially at small Fourier numbers. (4) Significant energy and time savings can be realized by reducing the processing or cooking time from  $Fo_1$  to  $Fo_2$ .

### PROBLEM 5.63

**KNOWN:** Long pyroceram rod, initially at a uniform temperature of 900 K, and clad with a thin metallic tube giving rise to a thermal contact resistance, is suddenly cooled by convection.

**FIND:** (a) Time required for rod centerline to reach 600 K, (b) Effect of convection coefficient on cooling rate.

**SCHEMATIC:**

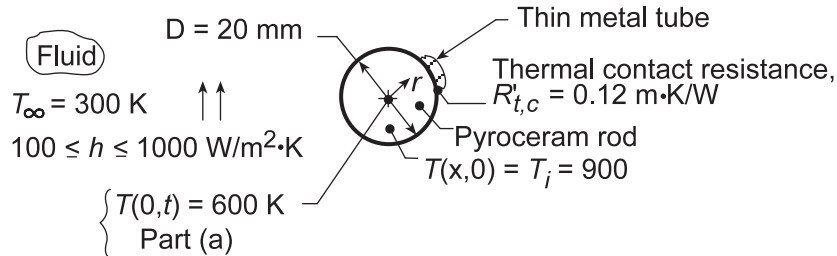

**ASSUMPTIONS:** (1) One-dimensional radial conduction, (2) Thermal resistance and capacitance of metal tube are negligible, (3) Constant properties, (4)  $Fo \geq 0.2$ .

**PROPERTIES:** Table A-2, Pyroceram ( $\bar{T} = (600 + 900)\text{K}/2 = 750 \text{ K}$ ):  $\rho = 2600 \text{ kg/m}^3$ ,  $c = 1100 \text{ J/kg} \cdot \text{K}$ ,  $k = 3.13 \text{ W/m} \cdot \text{K}$ .

**ANALYSIS:** (a) The thermal contact and convection resistances can be combined to give an overall heat transfer coefficient. Note that  $R'_{t,c}$  [m·K/W] is expressed per unit length for the outer surface. Hence, for  $h = 100 \text{ W/m}^2 \cdot \text{K}$ ,

$$U = \frac{1}{1/h + R'_{t,c}(\pi D)} = \frac{1}{1/100 \text{ W/m}^2 \cdot \text{K} + 0.12 \text{ m} \cdot \text{K/W}(\pi \times 0.020 \text{ m})} = 57.0 \text{ W/m}^2 \cdot \text{K}.$$

Using the approximate series solution, Eq. 5.52c, the Fourier number can be expressed as

$$Fo = -\left(1/\zeta_1^2\right) \ln\left(\theta_o^*/C_1\right).$$

From Table 5.1, find  $\zeta_1 = 0.5884 \text{ rad}$  and  $C_1 = 1.0441$  for

$$Bi = Ur_o/k = 57.0 \text{ W/m}^2 \cdot \text{K}(0.020 \text{ m}/2)/3.13 \text{ W/m} \cdot \text{K} = 0.182.$$

The dimensionless temperature is

$$\theta_o^*(0, Fo) = \frac{T(0,t) - T_\infty}{T_i - T_\infty} = \frac{(600 - 300) \text{ K}}{(900 - 300) \text{ K}} = 0.5.$$

Substituting numerical values to find  $Fo$  and then the time  $t$ ,

$$Fo = \frac{-1}{(0.5884)^2} \ln \frac{0.5}{1.0441} = 2.127$$

$$t = Fo \frac{r_o^2}{\alpha} = Fo \cdot r_o^2 \frac{\rho c}{k}$$

$$t = 2.127(0.020 \text{ m}/2)^2 2600 \text{ kg/m}^3 \times 1100 \text{ J/kg} \cdot \text{K} / 3.13 \text{ W/m} \cdot \text{K} = 194 \text{ s}. \quad \leftarrow$$

(b) The following temperature histories were generated using the IHT *Transient conduction Model* for a *Cylinder*.

Continued...

### PROBLEM 5.63 (Cont.)

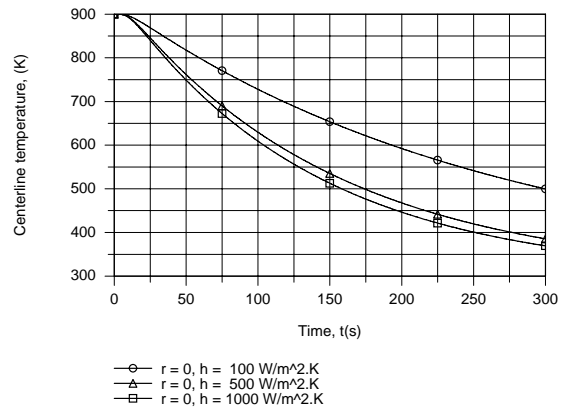
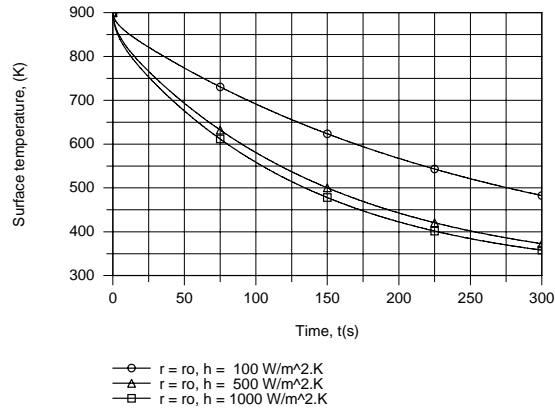

While enhanced cooling is achieved by increasing  $h$  from  $100 \text{ W/m}^2\cdot\text{K}$  to  $500 \text{ W/m}^2\cdot\text{K}$ , there is little benefit associated with increasing  $h$  from  $500 \text{ W/m}^2\cdot\text{K}$  to  $1000 \text{ W/m}^2\cdot\text{K}$ . The reason is that for  $h$  much above  $500 \text{ W/m}^2\cdot\text{K}$ , the contact resistance becomes the dominant contribution to the total resistance between the fluid and the rod, rendering the effect of further reductions in the convection resistance negligible. Note that, for  $h = 100, 500$  and  $1000 \text{ W/m}^2\cdot\text{K}$ , the corresponding values of  $U$  are  $57.0, 104.8$  and  $117.1 \text{ W/m}^2\cdot\text{K}$ , respectively.

**COMMENTS:** For Part (a), note that, since  $Fo = 2.127 > 0.2$ , Assumption (4) is satisfied.

## PROBLEM 5.64

**KNOWN:** Sapphire rod, initially at a uniform temperature of 800 K is suddenly cooled by a convection process; after 35 s, the rod is wrapped in insulation.

**FIND:** Temperature rod reaches after a long time following the insulation wrap.

**SCHEMATIC:**

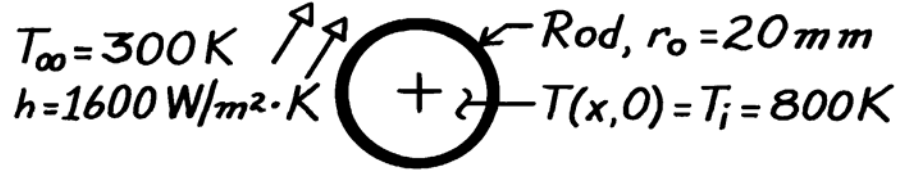

**ASSUMPTIONS:** (1) One-dimensional radial conduction, (2) Constant properties, (3) No heat losses from the rod when insulation is applied.

**PROPERTIES:** Table A-2, Aluminum oxide, sapphire (550K):  $\rho = 3970 \text{ kg/m}^3$ ,  $c = 1068 \text{ J/kg}\cdot\text{K}$ ,  $k = 22.3 \text{ W/m}\cdot\text{K}$ ,  $\alpha = 5.259 \times 10^{-6} \text{ m}^2/\text{s}$ .

**ANALYSIS:** First calculate the Biot number with  $L_c = r_o/2$ ,

$$Bi = \frac{h L_c}{k} = \frac{h (r_o/2)}{k} = \frac{1600 \text{ W/m}^2 \cdot \text{K} (0.020 \text{ m}/2)}{22.3 \text{ W/m}\cdot\text{K}} = 0.72.$$

Since  $Bi > 0.1$ , the rod cannot be approximated as a lumped capacitance system. The temperature distribution during the cooling process,  $0 \leq t \leq 35 \text{ s}$ , and for the time following the application of insulation,  $t > 35 \text{ s}$ , will appear as

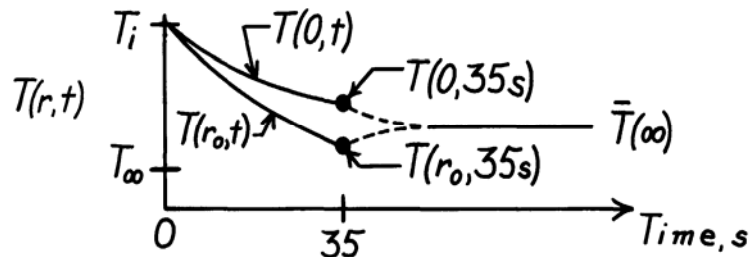

Eventually ( $t \rightarrow \infty$ ), the temperature of the rod will be uniform at  $\bar{T}(\infty)$ .

We begin by determining the energy transferred from the rod at  $t = 35 \text{ s}$ . We have

$$Bi = \frac{hr_o}{k} = \frac{1600 \text{ W/m}^2 \cdot \text{K} \times 0.020 \text{ m}}{22.3 \text{ W/m}\cdot\text{K}} = 1.43$$

$$Fo = \alpha t / r_o^2 = 5.259 \times 10^{-6} \text{ m}^2/\text{s} \times 35 \text{ s} / (0.02 \text{ m})^2 = 0.46$$

Since  $Fo > 0.2$ , we can use the one-term approximation. From Table 5.1,  $\zeta_1 = 1.4036 \text{ rad}$ ,  $C_1 = 1.2636$ . Then from Equation 5.49c,

$$\theta_o^* = C_1 \exp(-\zeta_1^2 Fo) = 1.2636 \exp(-1.4036^2 \times 0.46) = 0.5105$$

and from Equation 5.54

Continued...

**PROBLEM 5.64 (Cont.)**

$$\frac{Q}{Q_0} = 1 - \frac{2\theta_0^*}{\zeta_1} J_1(\zeta_1) = 1 - \frac{2 \times 0.5105}{1.4036} 0.5425 = 0.605$$

where  $J_1(\zeta_1)$  was found from App. B.4. Since the rod is well insulated after  $t = 35$  s, the energy transferred from the rod remains unchanged. To find  $\bar{T}(\infty)$ , write the conservation of energy requirement for the rod on a *time interval* basis,  $E_{\text{in}} - E_{\text{out}} = \Delta E \equiv E_{\text{final}} - E_{\text{initial}}$ . Using the nomenclature of Section 5.5.3 and basing energy relative to  $T_\infty$ , the energy balance becomes

$$-Q = \rho cV(\bar{T}(\infty) - T_\infty) - Q_0$$

where  $Q_0 = \rho cV(T_i - T_\infty)$ . Dividing through by  $Q_0$  and solving for  $\bar{T}(\infty)$ , find

$$\bar{T}(\infty) = T_\infty + (T_i - T_\infty)(1 - Q/Q_0).$$

Hence,

$$\bar{T}(\infty) = 300\text{K} + (800 - 300)\text{K} (1 - 0.408) = 596 \text{ K.}$$

<

### PROBLEM 5.65

**KNOWN:** Dimensions and initial temperature of stone mix concrete beam. Ambient temperature and convection heat transfer coefficient. Properties of aggregate beam.

**FIND:** Centerline temperature after  $t = 6$  hours for each beam.

**SCHEMATIC:**

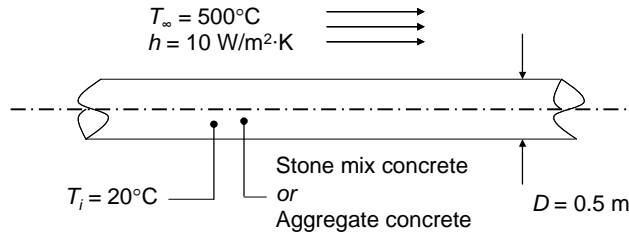

**ASSUMPTIONS:** (1) Constant properties. (2) Negligible radiation. (3) Beam is an infinite cylinder.

**PROPERTIES:** Table A.3: Stone mix concrete;  $k = 1.4 \text{ W/m}\cdot\text{K}$ ,  $\rho = 2300 \text{ kg/m}^3$ ,  $c_p = 880 \text{ J/kg}\cdot\text{K}$ .  
 Problem statement: Aggregate concrete:  $k = 0.789 \text{ W/m}\cdot\text{K}$ ,  $\rho = 1495 \text{ kg/m}^3$ ,  $c_p = 880 \text{ J/kg}\cdot\text{K}$ .

**ANALYSIS:** (a) To determine whether spatial effects are important, the Biot number is calculated in the conservative fashion

$$Bi = \frac{hr_o}{k} = \frac{hD}{2k} = \frac{10 \text{ W/m}^2 \cdot \text{K} \times 0.5 \text{ m}}{2 \times 1.4 \text{ W/m} \cdot \text{K}} = 1.78$$

The dimensionless time is

$$Fo = \frac{\alpha t}{r_o^2} = \frac{4kt}{\rho c D^2} = \frac{4 \times 1.4 \text{ W/m} \cdot \text{K} \times 6 \text{ h} \times 60 \text{ min/h} \times 60 \text{ s/min}}{2300 \text{ kg/m}^3 \times 880 \text{ J/kg} \cdot \text{K} \times (0.5 \text{ m})^2} = 0.24$$

Since  $Bi > 0.1$ , spatial effects are important. Because  $Fo > 0.2$ , the approximate solution of Section 5.6 is valid. From Table 5.1  $\zeta_1 = 1.52$  and  $C_1 = 1.31$ . Therefore,

$$\begin{aligned}
 T &= (T_i - T_\infty) C_1 \exp(-\zeta_1^2 Fo) + T_\infty \\
 &= (20^\circ\text{C} - 500^\circ\text{C}) \times 1.31 \times \exp(-1.52^2 \times 0.24) + 500^\circ\text{C} \\
 &= 139^\circ\text{C} \qquad \qquad \qquad <
 \end{aligned}$$

(b) The preceding calculations may be repeated for the aggregate concrete, yielding

$$Bi = 3.17, Fo = 0.21, \zeta_1 = 1.81, C_1 = 1.43, T = 155^\circ\text{C} \qquad <$$

**COMMENTS:** (1) Because both its thermal conductivity and density are small relative to the stone mix beam, the thermal diffusivity of the aggregate beam is approximately the same as that of the stone mix beam. Hence the Fourier numbers associated with the two materials are approximately equal. (2) Aggregate concrete is often preferred over a more dense concrete for fire protection purposes.

### PROBLEM 5.66

**KNOWN:** Long plastic rod of diameter  $D$  heated uniformly in an oven to  $T_i$  and then allowed to convectively cool in ambient air ( $T_\infty, h$ ) for a 3 minute period. Minimum temperature of rod should not be less than  $200^\circ\text{C}$  and the maximum-minimum temperature within the rod should not exceed  $10^\circ\text{C}$ .

**FIND:** Initial uniform temperature  $T_i$  to which rod should be heated. Whether the  $10^\circ\text{C}$  internal temperature difference is exceeded.

**SCHEMATIC:**

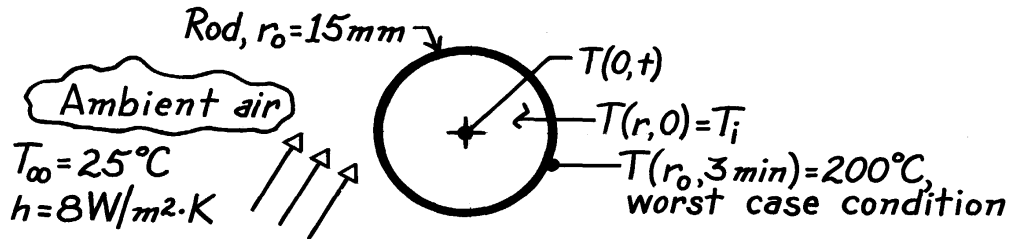

**ASSUMPTIONS:** (1) One-dimensional radial conduction, (2) Constant properties, (3) Uniform and constant convection coefficients.

**PROPERTIES:** Plastic rod (given):  $k = 0.3\text{ W/m}\cdot\text{K}$ ,  $\rho c_p = 1040\text{ kJ/m}^3\cdot\text{K}$ .

**ANALYSIS:** For the worst case condition, the rod cools for 3 minutes and its outer surface is at least  $200^\circ\text{C}$  in order that the subsequent pressing operation will be satisfactory. Hence,

$$\text{Bi} = \frac{hr_o}{k} = \frac{8\text{ W/m}^2\cdot\text{K} \times 0.015\text{ m}}{0.3\text{ W/m}\cdot\text{K}} = 0.40$$

$$\text{Fo} = \frac{\alpha t}{r_o^2} = \frac{k}{\rho c_p} \cdot \frac{t}{r_o^2} = \frac{0.3\text{ W/m}\cdot\text{K}}{1040 \times 10^3\text{ J/m}^3\cdot\text{K}} \times \frac{3 \times 60\text{ s}}{(0.015\text{ m})^2} = 0.2308.$$

Using Eq. 5.52a and  $\zeta_1 = 0.8516$  rad and  $C_1 = 1.0932$  from Table 5.1,

$$\theta^* = \frac{T(r_o, t) - T_\infty}{T_i - T_\infty} = C_1 J_0(\zeta_1 r_o^*) \exp(-\zeta_1^2 \text{Fo}).$$

With  $r_o^* = 1$ , from Table B.4,  $J_0(\zeta_1 \times 1) = J_0(0.8516) = 0.8263$ , giving

$$\frac{200 - 25}{T_i - 25} = 1.0932 \times 0.8263 \exp(-0.8516^2 \times 0.2308) \quad T_i = 254^\circ\text{C}. \quad <$$

At this time (3 minutes) what is the difference between the center and surface temperatures of the rod? From Eq. 5.52b,

$$\frac{\theta^*}{\theta_o} = \frac{T(r_o, t) - T_\infty}{T(0, t) - T_\infty} = \frac{200 - 25}{T(0, t) - 25} = J_0(\zeta_1 r_o^*) = 0.8263$$

which gives  $T(0, t) = 237^\circ\text{C}$ . Hence,

$$\Delta T = T(0, 180\text{ s}) - T(r_o, 180\text{ s}) = (237 - 200)^\circ\text{C} = 37^\circ\text{C}. \quad <$$

Hence, the desired max-min temperature difference sought ( $10^\circ\text{C}$ ) is not achieved.

**COMMENTS:**  $\Delta T$  could be reduced by decreasing the cooling rate; however,  $h$  can not be made much smaller. Two solutions are (a) increase ambient air temperature and (b) non-uniformly heat rod in oven by controlling its residence time.

### PROBLEM 5.67

**KNOWN:** Diameter and initial temperature of roller bearings. Temperature of oil bath and convection coefficient. Final centerline temperature. Number of bearings processed per hour.

**FIND:** Time required to reach centerline temperature. Cooling load.

**SCHEMATIC:**

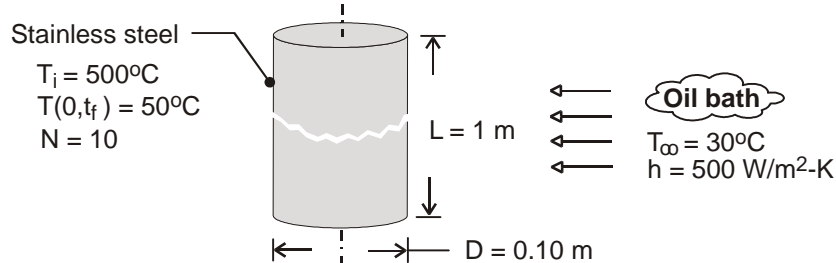

**ASSUMPTIONS:** (1) One-dimensional, radial conduction in rod, (2) Constant properties.

**PROPERTIES:** Table A.1, St. St. 304 ( $\bar{T} = 548 \text{ K}$ ):  $\rho = 7900 \text{ kg/m}^3$ ,  $k = 19.0 \text{ W/m}\cdot\text{K}$ ,  $c_p = 546 \text{ J/kg}\cdot\text{K}$ ,  $\alpha = 4.40 \times 10^{-6} \text{ m}^2/\text{s}$ .

**ANALYSIS:** With  $Bi = h(r_o/2)/k = 0.658$ , the lumped capacitance method can not be used. From the one-term approximation of Eq. 5.52c for the centerline temperature,

$$\theta_o^* = \frac{T_o - T_\infty}{T_i - T_\infty} = \frac{50 - 30}{500 - 30} = 0.0426 = C_1 \exp(-\zeta_1^2 Fo) = 1.1382 \exp[-(0.9287)^2 Fo]$$

where, for  $Bi = hr_o/k = 1.316$ ,  $C_1 = 1.2486$  and  $\zeta_1 = 1.3643$  from Table 5.1.

$$Fo = -\ln(0.0341)/1.86 = 1.82$$

$$t_f = Fo r_o^2 / \alpha = 1.82 (0.05 \text{ m})^2 / 4.40 \times 10^{-6} = 1031 \text{ s} = 17 \text{ min} \quad <$$

From Eqs. 5.47 and 5.54, the energy extracted from a single rod is

$$Q = \rho c V (T_i - T_\infty) \left[ 1 - \frac{2\theta_o^*}{\zeta_1} J_1(\zeta_1) \right]$$

With  $J_1(1.3643) = 0.535$  from Table B.4,

$$Q = 7900 \text{ kg/m}^3 \times 546 \text{ J/kg}\cdot\text{K} \left[ \pi (0.05 \text{ m})^2 1 \text{ m} \right] 470 \text{ K} \left[ 1 - \frac{0.0852 \times 0.535}{1.3643} \right] = 1.54 \times 10^7 \text{ J}$$

The nominal cooling load is

$$\bar{q} = \frac{NQ}{t_f} = \frac{10 \times 1.54 \times 10^7 \text{ J}}{1031 \text{ s}} = 1.49 \times 10^5 \text{ W} = 149 \text{ kW} \quad <$$

**COMMENTS:** For a centerline temperature of  $50^\circ\text{C}$ , Eq. 5.52b yields a surface temperature of

$$T(r_o, t) = T_\infty + (T_i - T_\infty) \theta_o^* J_o(\zeta_1) = 30^\circ\text{C} + 470^\circ\text{C} \times 0.0426 \times 0.586 = 41.7^\circ\text{C}$$



### PROBLEM 5.68

**KNOWN:** Long rods of 40 mm- and 80-mm diameter at a uniform temperature of 400°C in a curing oven, are removed and cooled by forced convection with air at 25°C. The 40-mm diameter rod takes 280 s to reach a *safe-to-handle* temperature of 60°C.

**FIND:** Time it takes for a 80-mm diameter rod to cool to the same safe-to-handle temperature. Comment on the result? Did you anticipate this outcome?

**SCHEMATIC:**

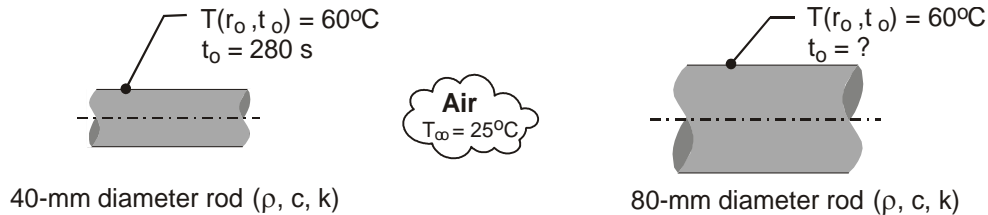

**ASSUMPTIONS:** (1) One-dimensional radial (cylindrical) conduction in the rods, (2) Constant properties, and (3) Convection coefficient same value for both rods.

**PROPERTIES:** Rod (*given*):  $\rho = 2500 \text{ kg/m}^3$ ,  $c = 900 \text{ J/kg}\cdot\text{K}$ ,  $k = 15 \text{ W/m}\cdot\text{K}$ .

**ANALYSIS:** Not knowing the convection coefficient, the Biot number cannot be calculated to determine whether the rods behave as spacewise isothermal objects. Using the relations from Section 5.6, Radial Systems with Convection, for the infinite cylinder, Eq. 5.52, evaluate

$Fo = \alpha t / r_o^2$ , and knowing  $T(r_o, t_o)$ , a trial-and-error solution is required to find  $Bi = h r_o / k$  and hence,  $h$ . Using the *IHT Transient Conduction* model for the *Cylinder*, the following results are readily calculated for the 40-mm rod. With  $t_o = 280 \text{ s}$ ,

$$Fo = 4.667 \qquad Bi = 0.264 \qquad h = 197.7 \text{ W/m}^2 \cdot \text{K}$$

For the 80-mm rod, with the foregoing value for  $h$ , with  $T(r_o, t_o) = 60^\circ\text{C}$ , find

$$Bi = 0.528 \qquad Fo = 2.413 \qquad t_o = 579 \text{ s} \qquad <$$

**COMMENTS:** (1) The time-to-cool,  $t_o$ , for the 80-mm rod is slightly more than twice that for the 40-mm rod. Did you anticipate this result? Did you believe the times would be proportional to the diameter squared?

(2) The simplest approach to explaining the relationship between  $t_o$  and the diameter follows from the lumped capacitance analysis, Eq. 5.13, where for the same  $\theta/\theta_i$ , we expect  $Bi \cdot Fo_o$  to be a constant. That is,

$$\frac{h \cdot r_o}{k} \times \frac{\alpha t_o}{r_o^2} = C$$

yielding  $t_o \sim r_o$  (not  $r_o^2$ ).

### PROBLEM 5.69

**KNOWN:** Initial temperature, density, specific heat and diameter of cylindrical rod. Convection coefficient and temperature of air flow. Time for centerline to reach a prescribed temperature. Dependence of convection coefficient on flow velocity.

**FIND:** (a) Thermal conductivity of material, (b) Effect of velocity and centerline temperature and temperature histories for selected velocities.

**SCHEMATIC:**

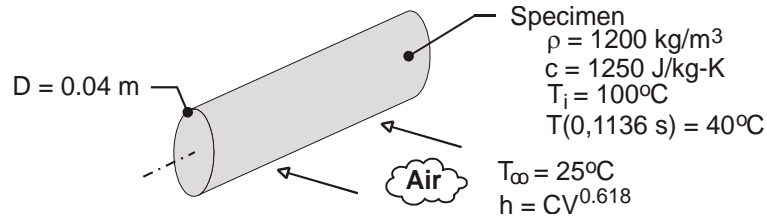

**ASSUMPTIONS:** (1) Lumped capacitance analysis can not be used but one-term approximation for an infinite cylinder is appropriate, (2) One-dimensional conduction in  $r$ , (3) Constant properties, (4) Negligible radiation, (5) Negligible effect of thermocouple hole on conduction.

**ANALYSIS:** (a) With  $\theta_o^* = [T_o(0, 1136 \text{ s}) - T_\infty] / (T_i - T_\infty) = (40 - 25) / (100 - 25) = 0.20$ , Eq. 5.52c yields

$$Fo = \frac{\alpha t}{r_o^2} = \frac{k t}{\rho c_p r_o^2} = \frac{k(1136 \text{ s})}{1200 \text{ kg/m}^3 \times 1250 \text{ J/kg}\cdot\text{K} \times (0.02 \text{ m})^2} = -\ln(0.2 / C_1) / \zeta_1^2 \quad (1)$$

Because  $C_1$  and  $\zeta_1$  depend on  $Bi = hr_o/k$ , a trial-and-error procedure must be used. For example, a value of  $k$  may be assumed and used to calculate  $Bi$ , which may then be used to obtain  $C_1$  and  $\zeta_1$  from Table 5.1. Substituting  $C_1$  and  $\zeta_1$  into Eq. (1),  $k$  may be computed and compared with the assumed value. Iteration continues until satisfactory convergence is obtained, with

$$k \approx 0.30 \text{ W/m}\cdot\text{K}$$

<

and, hence,  $Bi = 3.67$ ,  $C_1 = 1.45$ ,  $\zeta_1 = 1.87$  and  $Fo = 0.568$ . For the above value of  $k$ ,

$-\ln(0.2 / C_1) / \zeta_1^2 = 0.567$ , which equals the Fourier number, as prescribed by Eq. (1).

(b) With  $h = 55 \text{ W/m}^2\cdot\text{K}$  for  $V = 6.8 \text{ m/s}$ ,  $h = CV^{0.618}$  yields a value of  $C = 16.8 \text{ W}\cdot\text{s}^{0.618}/\text{m}^{2.618}\cdot\text{K}$ . The desired variations of the centerline temperature with velocity (for  $t = 1136 \text{ s}$ ) and time (for  $V = 3, 10$  and  $20 \text{ m/s}$ ) are as follows:

Continued .....

### PROBLEM 5.69 (Cont.)

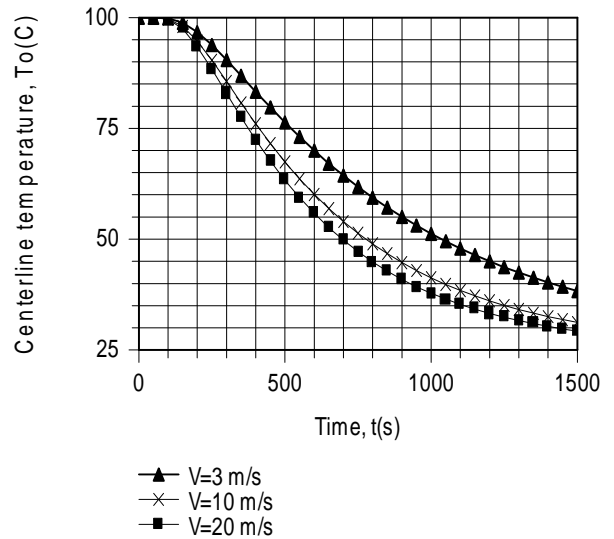
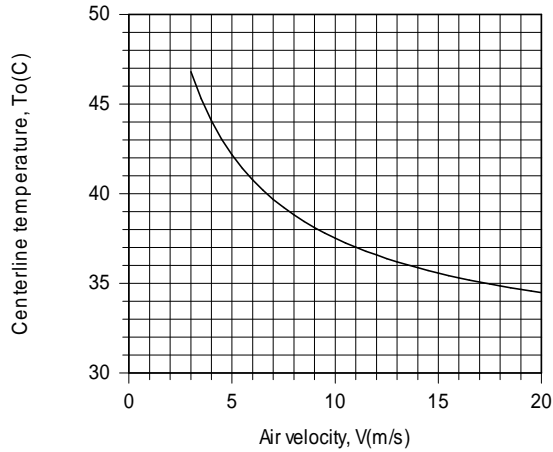

With increasing  $V$  from 3 to 20 m/s,  $h$  increases from 33 to 107  $\text{W/m}^2\cdot\text{K}$ , and the enhanced cooling reduces the centerline temperature at the prescribed time. The accelerated cooling associated with increasing  $V$  is also revealed by the temperature histories, and the time required to achieve thermal equilibrium between the air and the cylinder decreases with increasing  $V$ .

**COMMENTS:** (1) For the smallest value of  $h = 33 \text{ W/m}^2\cdot\text{K}$ ,  $\text{Bi} \equiv h (r_0/2)/k = 1.1 \gg 0.1$ , and use of the lumped capacitance method is clearly inappropriate.

(2) The *IHT* Transient Conduction Model for a cylinder was used to perform the calculations of Part (b). Because the model is based on the exact solution, Eq. 5.50a, it is accurate for values of  $\text{Fo} < 0.2$ , as well as  $\text{Fo} > 0.2$ . Although in principle, the model may be used to calculate the thermal conductivity for the conditions of Part (a), convergence is elusive and may only be achieved if the initial guesses are close to the correct results.

## PROBLEM 5.70

**KNOWN:** Diameter, initial temperature and properties of stainless steel rod. Temperature and convection coefficient of coolant.

**FIND:** Temperature distributions for prescribed convection coefficients and times.

**SCHEMATIC:**

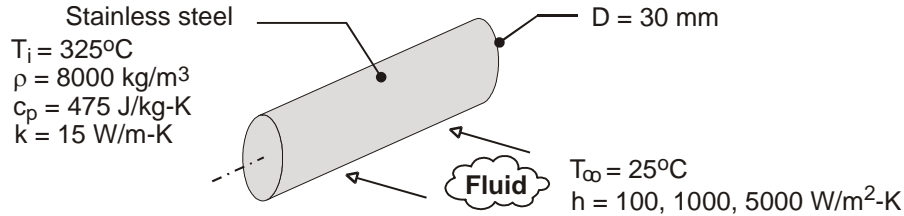

**ASSUMPTIONS:** (1) One-dimensional radial conduction, (2) Constant properties.

**ANALYSIS:** The *IHT* model is based on the exact solution to the heat equation, Eq. 5.50. The results are plotted as follows

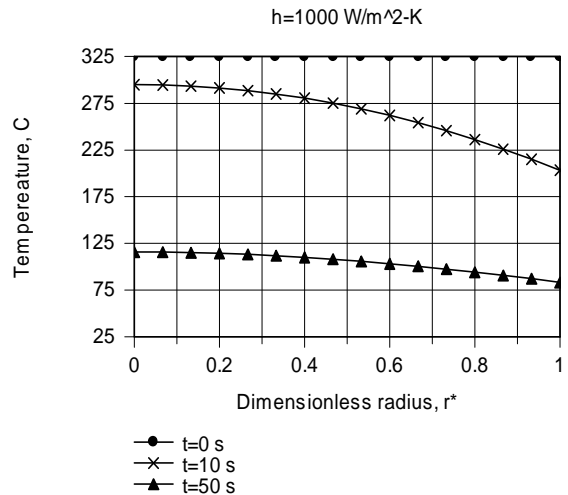
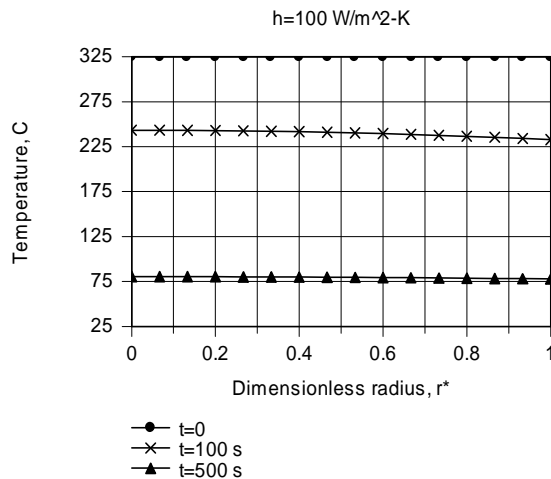

For  $h = 100 \text{ W/m}^2\cdot\text{K}$ ,  $Bi = hr_o/k = 0.1$ , and as expected, the temperature distribution is nearly uniform throughout the rod. For  $h = 1000 \text{ W/m}^2\cdot\text{K}$  ( $Bi = 1$ ), temperature variations within the rod are not negligible. In this case the centerline-to-surface temperature difference is comparable to the surface-to-fluid temperature difference. For  $h = 5000 \text{ W/m}^2\cdot\text{K}$  ( $Bi = 5$ ), temperature variations within the rod are large and  $[T(0,t) - T(r_o,t)]$  is substantially larger than  $[T(r_o,t) - T_\infty]$ .

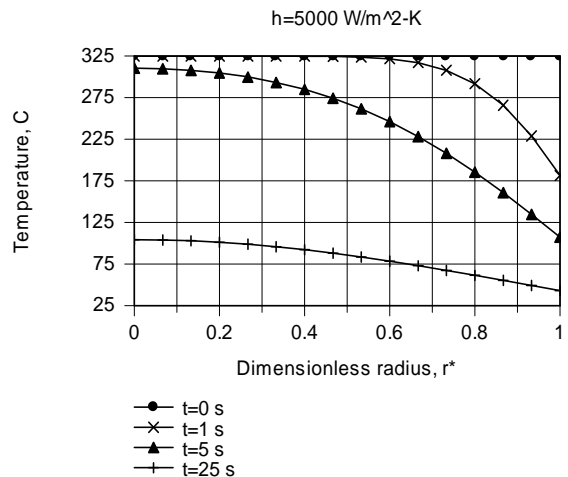

**COMMENTS:** With increasing  $Bi$ , conduction within the rod, and not convection from the surface, becomes the limiting process for heat loss.

### PROBLEM 5.71

**KNOWN:** A ball bearing is suddenly immersed in a molten salt bath; heat treatment to harden occurs at locations with  $T > 1000$  K.

**FIND:** Time required to harden outer layer of 1mm.

**SCHEMATIC:**

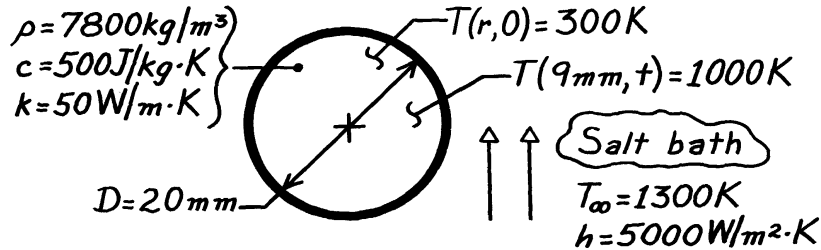

**ASSUMPTIONS:** (1) One-dimensional radial conduction, (2) Constant properties, (3)  $Bi \geq 0.2$ .

**ANALYSIS:** Since any location within the ball whose temperature exceeds 1000 K will be hardened, the problem is to find the time when the location  $r = 9$  mm reaches 1000 K. Then a 1 mm outer layer will be hardened. Begin by finding the Biot number.

$$Bi = \frac{h r_o}{k} = \frac{5000 \text{ W/m}^2 \cdot \text{K} (0.020 \text{ m}/2)}{50 \text{ W/m}\cdot\text{K}} = 1.00.$$

Using the one-term approximate solution for a sphere, find

$$Fo = -\frac{1}{\zeta_1^2} \ln \left[ \theta^* / C_1 \frac{1}{\zeta_1 r^*} \sin(\zeta_1 r^*) \right].$$

From Table 5.1 with  $Bi = 1.00$ , for the sphere find  $\zeta_1 = 1.5708$  rad and  $C_1 = 1.2732$ . With  $r^* = r/r_o = (9 \text{ mm}/10 \text{ mm}) = 0.9$ , substitute numerical values.

$$Fo = \frac{-1}{(1.5708)^2} \ln \left[ \frac{(1000 - 1300) \text{ K}}{(300 - 1300) \text{ K}} / 1.2732 \frac{1}{1.5708 \times 0.9} \sin(1.5708 \times 0.9 \text{ rad}) \right] = 0.441.$$

From the definition of the Fourier number with  $\alpha = k/\rho c$ ,

$$t = Fo \frac{r_o^2}{\alpha} = Fo \cdot r_o^2 \frac{\rho c}{k} = 0.441 \times \left[ \frac{0.020 \text{ m}}{2} \right]^2 7800 \frac{\text{kg}}{\text{m}^3} \times 500 \frac{\text{J}}{\text{kg}\cdot\text{K}} / 50 \text{ W/m}\cdot\text{K} = 3.4 \text{ s.} \quad <$$

**COMMENTS:** (1) Note the very short time required to harden the ball. At this time it can be easily shown the center temperature is  $T(0, 3.4 \text{ s}) = 871$  K.

## PROBLEM 5.72

**KNOWN:** Steel ball bearings at an initial, uniform temperature are to be cooled by convection while passing through a refrigerated chamber; bearings are to be cooled to a temperature such that 70% of the thermal energy is removed.

**FIND:** Residence time of the balls in the 5 m-long chamber and recommended drive velocity for the conveyor.

**SCHEMATIC:**

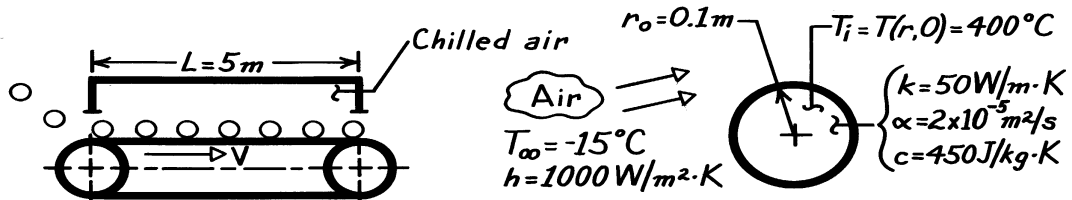

**ASSUMPTIONS:** (1) Negligible conduction between ball and conveyor surface, (2) Negligible radiation exchange with surroundings, (3) Constant properties, (4) Uniform convection coefficient over ball's surface.

**ANALYSIS:** The Biot number for the lumped capacitance analysis is

$$Bi \equiv \frac{hL_c}{k} = \frac{h(r_o/3)}{k} = \frac{1000 \text{ W/m}^2 \cdot \text{K} (0.1\text{m}/3)}{50 \text{ W/m} \cdot \text{K}} = 0.67.$$

Since  $Bi > 0.1$ , lumped capacitance analysis is not appropriate. We assume that the one-term approximation to the exact solution is valid and check later. The Biot number for the exact solution is

$$Bi = \frac{hr_o}{k} = \frac{1000 \text{ W/m}^2 \cdot \text{K} \times 0.1\text{m}}{50 \text{ W/m} \cdot \text{K}} = 2.0,$$

From Table 5.1,  $\zeta_1 = 2.0288$ ,  $C_1 = 1.4793$ . From Equation 5.55, with  $Q/Q_o = 0.70$ , we can solve for  $\theta_o^*$ :

$$\theta_o^* = \left(1 - \frac{Q}{Q_o}\right) \frac{\zeta_1^3}{3[\sin(\zeta_1) - \zeta_1 \cos(\zeta_1)]} = (1 - 0.7) \frac{2.0288^3}{3[\sin(2.0288) - 2.0288 \cos(2.0288)]} = 0.465$$

From Eq. 5.53c, we can solve for  $Fo$ :

$$Fo = -\frac{1}{\zeta_1^2} \ln(\theta_o^*/C_1) = -\frac{1}{2.0288^2} \ln(0.465/1.4793) = 0.281$$

Note that the one-term approximation is indeed valid, since  $Fo > 0.2$ . Then

$$t = Fo \frac{r_o^2}{\alpha} = 0.281 \frac{(0.1 \text{ m})^2}{2 \times 10^{-5} \text{ m}^2/\text{s}} = 140 \text{ s}$$

The velocity of the conveyor is expressed in terms of the length  $L$  and residence time  $t$ . Hence

$$V = \frac{L}{t} = \frac{5 \text{ m}}{140 \text{ s}} = 0.036 \text{ m/s} = 36 \text{ mm/s.} \quad <$$

**COMMENTS:** Referring to Equation 5.10, note that for a sphere, the characteristic length is

$$L_c = V/A_s = \frac{4}{3} \pi r_o^3 / 4\pi r_o^2 = \frac{r_o}{3}.$$

However, when using the exact solution or one-term approximation, note that  $Bi \equiv h r_o/k$ .

### PROBLEM 5.73

**KNOWN:** Glass sphere diameter and bakelite shell thickness. Initial solid temperature, fluid temperature, convection heat transfer coefficient, and heating time.

**FIND:** Center temperature of glass sphere after specified heating time.

**SCHEMATIC:**

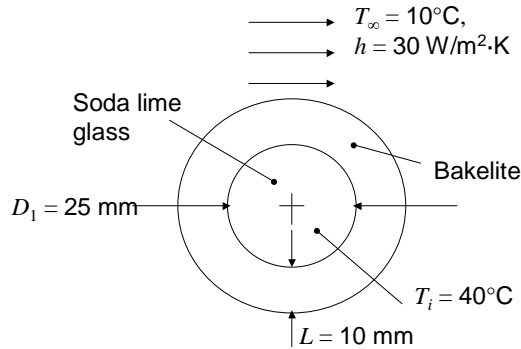

**ASSUMPTIONS:** (1) One-dimensional conduction, (2) Constant properties, (3) Negligible contact resistance.

**PROPERTIES:** Table A.3, soda lime glass ( $T = 25^\circ\text{C}$ ),  $\rho = 2500 \text{ kg/m}^3$ ,  $k = 1.4 \text{ W/m}\cdot\text{K}$ ,  $c_p = 750 \text{ J/kg}\cdot\text{K}$ . Table A.3, bakelite ( $T = 25^\circ\text{C}$ ),  $\rho = 1300 \text{ kg/m}^3$ ,  $k = 1.4 \text{ W/m}\cdot\text{K}$ ,  $c_p = 1465 \text{ J/kg}\cdot\text{K}$ .

**ANALYSIS:** The thermal diffusivities of the bakelite and glass are

$$\alpha_b = \frac{k}{\rho c_p} = \frac{1.4 \text{ W/m}\cdot\text{K}}{1300 \text{ kg/m}^3 \times 1465 \text{ J/kg}\cdot\text{K}} = 735 \times 10^{-9} \text{ m}^2/\text{s}$$

$$\alpha_g = \frac{k}{\rho c_p} = \frac{1.4 \text{ W/m}\cdot\text{K}}{2500 \text{ kg/m}^3 \times 750 \text{ J/kg}\cdot\text{K}} = 747 \times 10^{-9} \text{ m}^2/\text{s}$$

Since  $\alpha_b \approx \alpha_g$ , it is reasonable to assign a uniform thermal diffusivity of  $\alpha = 740 \times 10^{-9} \text{ m}^2/\text{s}$  to the composite sphere. Since  $k_b = k_g$  and the thermal contact resistance between the glass and bakelite is negligible, we may treat the composite sphere as a single sphere of diameter  $D = D_1 + 2L = 25 \text{ mm} + 20 \text{ mm} = 45 \text{ mm}$  with uniform properties. The Biot number for the single sphere is

$$Bi = \frac{h(D/6)}{k} = \frac{30 \text{ W/m}^2 \cdot \text{K} \times (45 \times 10^{-3} \text{ m}/6)}{1.4 \text{ W/m}\cdot\text{K}} = 0.16$$

Therefore the lumped capacitance approximation is not valid. The Fourier number is

$$Fo = \frac{\alpha t}{(D/2)^2} = \frac{740 \times 10^{-9} \text{ m}^2/\text{s} \times 200 \text{ s}}{(45 \times 10^{-3} \text{ m}/2)^2} = 0.291$$

Since  $Fo > 0.2$ , the single term approximation is valid. From Table 5.1 with  $Bi = h(D/2)/k = 30 \text{ W/m}^2 \cdot \text{K} \times (45 \times 10^{-3} \text{ m}/2)/1.4 \text{ W/m}\cdot\text{K} = 0.482$ ,  $\zeta_1 = 1.145$ ,  $C_1 = 1.139$ . Hence

$$\theta_o^* = \frac{T - T_\infty}{T_i - T_\infty} = C_1 \exp(-\zeta_1^2 Fo) = 1.139 \exp(-1.145^2 \times 0.291) = 0.817$$

Continued...

### PROBLEM 5.73 (Cont.)

Therefore,  $T = 0.817 \times (40 - 10^\circ\text{C}) + 10^\circ\text{C} = 34.5^\circ\text{C}$

<

**COMMENTS:** (1) If the thermal diffusivities and thermal conductivities of the bakelite and soda lime glass were of sufficiently different value, or the thermal contact resistance was not negligible, a more detailed analytical or numerical solution would be required. (2) The Biot number used in conjunction with Table 5.1 is based upon the sphere radius.



### PROBLEM 5.74

**KNOWN:** Diameter and initial temperature of ball bearings to be quenched in an oil bath.

**FIND:** (a) Time required for surface to cool to 100°C and the corresponding center temperature, (b) Oil bath cooling requirements.

**SCHEMATIC:**

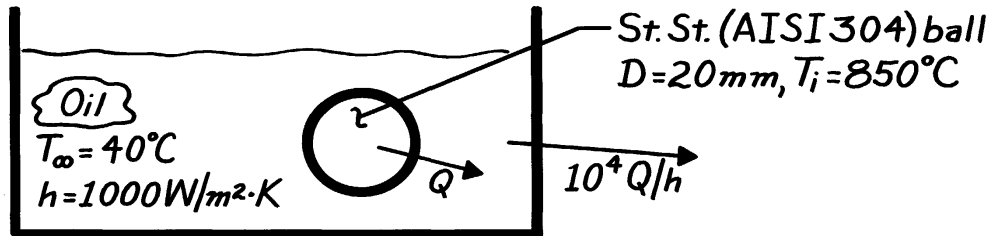

**ASSUMPTIONS:** (1) One-dimensional radial conduction in ball bearings, (2) Constant properties.

**PROPERTIES:** Table A-1, St. St., AISI 304, ( $T \approx 500^\circ\text{C}$ ):  $k = 22.2 \text{ W/m}\cdot\text{K}$ ,  $c_p = 579 \text{ J/kg}\cdot\text{K}$ ,  $\rho = 7900 \text{ kg/m}^3$ ,  $\alpha = 4.85 \times 10^{-6} \text{ m}^2/\text{s}$ .

**ANALYSIS:** (a) To determine whether use of the lumped capacitance method is suitable, first compute

$$Bi = \frac{h(r_o/3)}{k} = \frac{1000 \text{ W/m}^2 \cdot \text{K} (0.010 \text{ m}/3)}{22.2 \text{ W/m}\cdot\text{K}} = 0.15.$$

We conclude that, although the lumped capacitance method could be used as a first approximation, the exact solution should be used in the interest of improving accuracy. We assume that the one-term approximation is valid and check later. Hence, with

$$Bi = \frac{hr_o}{k} = \frac{1000 \text{ W/m}^2 \cdot \text{K} (0.01 \text{ m})}{22.2 \text{ W/m}\cdot\text{K}} = 0.450$$

from Table 5.1,  $\zeta_1 = 1.1092$ ,  $C_1 = 1.1301$ . Then

$$\theta^*(r^* = 1, Fo) = \frac{T(r_o, t) - T_\infty}{T_i - T_\infty} = \frac{100^\circ\text{C} - 40^\circ\text{C}}{850^\circ\text{C} - 40^\circ\text{C}} = 0.0741$$

and Equation 5.53b can be solved for  $\theta_o^*$ :

$$\theta_o^* = \theta^* \zeta_1 r^* / \sin(\zeta_1 r^*) = 0.0741 \times 1.1092 \times 1 / \sin(1.1092) = 0.0918$$

Then Equation 5.53c can be solved for Fo:

$$Fo = -\frac{1}{\zeta_1^2} \ln(\theta_o^* / C_1) = -\frac{1}{1.1092^2} \ln(0.0918 / 1.1301) = 2.04$$

$$t = \frac{r_o^2 Fo}{\alpha} = \frac{(0.01 \text{ m})^2 (2.04)}{4.85 \times 10^{-6} \text{ m}^2/\text{s}} = 42 \text{ s.} \quad <$$

Note that the one-term approximation is accurate, since  $Fo > 0.2$ .

Continued ...

### PROBLEM 5.74 (Cont.)

Also,

$$\theta_o = T_o - T_\infty = 0.0918(T_i - T_\infty) = 0.0918(850 - 40) = 74^\circ\text{C}$$

$$T_o = 114^\circ\text{C}$$

<

(b) Equation 5.55 can be used to calculate the heat loss from a single ball:

$$\frac{Q}{Q_o} = 1 - \frac{3\theta_o^*}{\zeta_1^3} [\sin(\zeta_1) - \zeta_1 \cos(\zeta_1)] = 1 - \frac{3 \times 0.0918}{1.1092^3} [\sin(1.1092) - 1.1092 \cos(1.1092)] = 0.919$$

Hence, from Equation 5.47,

$$Q = 0.919 \rho c_p V (T_i - T_\infty)$$

$$Q = 0.919 \times 7900 \text{ kg/m}^3 \times 579 \text{ J/kg} \cdot \text{K} \times \frac{\pi}{6} (0.02 \text{ m})^3 \times 810^\circ\text{C}$$

$$Q = 1.43 \times 10^4 \text{ J}$$

is the amount of energy transferred from a single ball during the cooling process. Hence, the oil bath cooling rate must be

$$q = 10^4 Q / 3600 \text{ s}$$

$$q = 4 \times 10^4 \text{ W} = 40 \text{ kW.}$$

<

**COMMENTS:** If the lumped capacitance method is used, the cooling time, obtained from Equation 5.5, would be  $t = 39.7 \text{ s}$ , where the ball is assumed to be uniformly cooled to  $100^\circ\text{C}$ . This result, and the fact that  $T_o - T(r_o) = 15^\circ\text{C}$  at the conclusion, suggests that use of the lumped capacitance method would have been reasonable.

## PROBLEM 5.75

**KNOWN:** Sphere quenching in a constant temperature bath.

**FIND:** (a) Plot  $T(0,t)$  and  $T(r_o,t)$  as function of time, (b) Time required for surface to reach 415 K,  $t'$ , (c) Heat flux when  $T(r_o, t') = 415$  K, (d) Energy lost by sphere in cooling to  $T(r_o, t') = 415$  K, (e) Steady-state temperature reached after sphere is insulated at  $t = t'$ , (f) Effect of  $h$  on center and surface temperature histories.

**SCHEMATIC:**

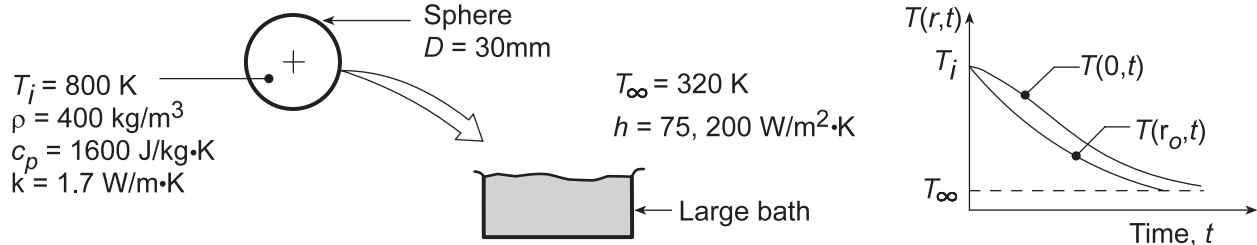

**ASSUMPTIONS:** (1) One-dimensional radial conduction, (2) Constant properties, (3) Uniform initial temperature.

**ANALYSIS:** (a) Calculate Biot number to determine if sphere behaves as spatially isothermal object,

$$Bi = \frac{hL_c}{k} = \frac{h(r_o/3)}{k} = \frac{75 \text{ W/m}^2 \cdot \text{K} (0.015 \text{ m/3})}{1.7 \text{ W/m} \cdot \text{K}} = 0.22.$$

Hence, temperature gradients exist in the sphere and  $T(r,t)$  vs.  $t$  appears as shown above.

(b) The exact solution may be used to find  $t'$  when  $T(r_o, t') = 415$  K. We assume that the one-term approximation is valid and check later. Hence, with

$$Bi = \frac{hr_o}{k} = \frac{75 \text{ W/m}^2 \cdot \text{K} (0.015 \text{ m})}{1.7 \text{ W/m} \cdot \text{K}} = 0.662$$

from Table 5.1,  $\zeta_1 = 1.3188$ ,  $C_1 = 1.1877$ . Then

$$\theta^*(r^* = 1, Fo) = \frac{T(r_o, t) - T_\infty}{T_i - T_\infty} = \frac{415^\circ\text{C} - 320^\circ\text{C}}{800^\circ\text{C} - 320^\circ\text{C}} = 0.1979$$

and Equation 5.53b can be solved for  $\theta_o^*$ :

$$\theta_o^* = \theta^* \zeta_1 r^* / \sin(\zeta_1 r^*) = 0.1979 \times 1.3188 \times 1 / \sin(1.3188) = 0.2695$$

Then Equation 5.53c can be solved for  $Fo$ :

$$Fo = -\frac{1}{\zeta_1^2} \ln\left(\frac{\theta_o^*}{C_1}\right) = -\frac{1}{1.3188^2} \ln(0.2695/1.1877) = 0.853$$

$$t' = Fo \frac{r_o^2}{\alpha} = Fo \cdot \frac{\rho c_p}{k} \cdot r_o^2 = 0.853 \frac{400 \text{ kg/m}^3 \times 1600 \text{ J/kg}\cdot\text{K}}{1.7 \text{ W/m}\cdot\text{K}} \times (0.015 \text{ m})^2 = 72 \text{ s} \quad <$$

Note that the one-term approximation is accurate, since  $Fo > 0.2$ .

Continued...

### PROBLEM 5.75 (Cont.)

(c) The heat flux at the outer surface at time  $t'$  is given by Newton's law of cooling

$$q'' = h [T(r_o, t') - T_\infty] = 75 \text{ W/m}^2 \cdot \text{K} [415 - 320] \text{ K} = 7125 \text{ W/m}^2. \quad \leftarrow$$

The manner in which  $q''$  is calculated indicates that energy is leaving the sphere.

(d) The energy lost by the sphere during the cooling process from  $t = 0$  to  $t'$  can be determined from Equation 5.55:

$$\frac{Q}{Q_o} = 1 - \frac{3\theta_o^*}{\zeta_1^3} [\sin(\zeta_1) - \zeta_1 \cos(\zeta_1)] = 1 - \frac{3 \times 0.2695}{1.3188^3} [\sin(1.3188) - 1.3188 \cos(1.3188)] = 0.775$$

The energy loss by the sphere with  $V = (\pi D^3)/6$  is therefore, from Equation 5.47,

$$Q = 0.775 Q_o = 0.775 \rho \left( \pi D^3 / 6 \right) c_p (T_i - T_\infty)$$

$$Q = 0.775 \times 400 \text{ kg/m}^3 \left( \pi [0.030 \text{ m}]^3 / 6 \right) 1600 \text{ J/kg} \cdot \text{K} (800 - 320) \text{ K} = 3364 \text{ J} \quad \leftarrow$$

(e) If at time  $t'$  the surface of the sphere is perfectly insulated, eventually the temperature of the sphere will be uniform at  $T(\infty)$ . Applying conservation of energy to the sphere over a *time interval*,  $E_{in} - E_{out} = \Delta E \equiv E_{final} - E_{initial}$ . Hence,  $-Q = \rho c V [T(\infty) - T_\infty] - Q_o$ , where  $Q_o \equiv \rho c V [T_i - T_\infty]$ . Dividing by  $Q_o$  and regrouping, we obtain

$$T(\infty) = T_\infty + (1 - Q/Q_o)(T_i - T_\infty) = 320 \text{ K} + (1 - 0.775)(800 - 320) \text{ K} = 428 \text{ K} \quad \leftarrow$$

(f) Using the *IHT Transient Conduction Model for a Sphere*, the following graphical results were generated.

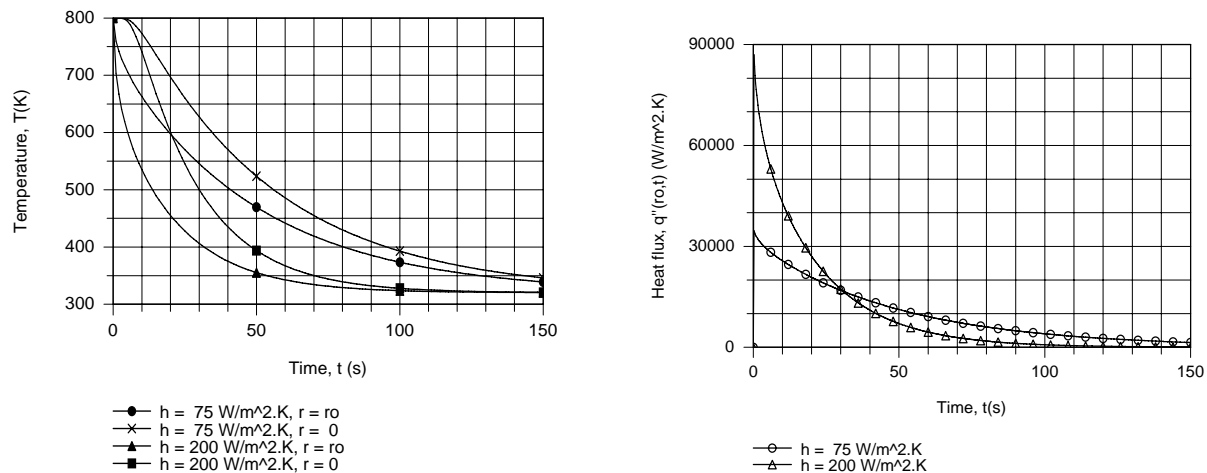

The quenching process is clearly accelerated by increasing  $h$  from 75 to 200 W/m<sup>2</sup>·K and is virtually completed by  $t \approx 100$ s for the larger value of  $h$ . Note that, for both values of  $h$ , the temperature difference  $[T(0, t) - T(r_o, t)]$  decreases with increasing  $t$ . Although the surface heat flux for  $h = 200$  W/m<sup>2</sup>·K is initially larger than that for  $h = 75$  W/m<sup>2</sup>·K, the more rapid decline in  $T(r_o, t)$  causes it to become smaller at  $t \approx 30$ s.

**COMMENTS:** Using the *Transient Conduction/Sphere* model in *IHT* based upon multiple-term series solution, the following results were obtained:  $t' = 72.1$  s;  $Q/Q_o = 0.7745$ , and  $T(\infty) = 428$  K.

### PROBLEM 5.76

**KNOWN:** One-dimensional convective heating of sphere of radius  $r_o$ , with  $Bi = 1$  for a dimensionless time of  $Fo_1$ .

**FIND:** (a) Sketch of the dimensionless center and surface temperatures of the sphere as a function of dimensionless time over the range  $0 < Fo_1 < Fo < \infty$ . Relative value of  $Fo_2$  needed to achieve a steady-state center temperature equal to the center temperature at  $Fo_1$ . (b) Analytical expression for, and value of  $\Delta Fo = Fo_2 - Fo_1$  for  $Bi = 1$ ,  $Fo_1 > 0.2$ ,  $Fo_2 > 0.2$ . (c) Value of  $\Delta Fo$  for  $Bi = 0.01, 0.1, 10, 100$  and  $\infty$ .

**SCHEMATIC:**

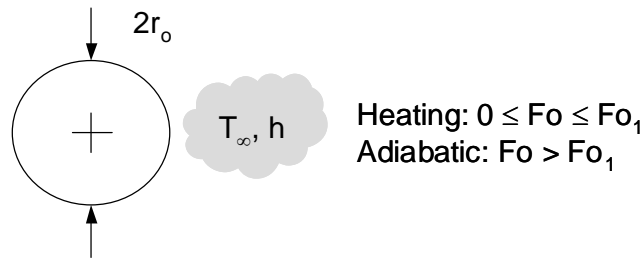

**ASSUMPTIONS:** (1) One-dimensional conduction, (2) Constant properties, (3) Approximate, one-term solutions are valid.

**ANALYSIS:** (a) A sketch of the dimensionless center and surface temperatures is shown below. Note that, at  $Fo_1$ , the surface of the sphere will be warm (smaller  $\theta$ ) relative to its center since temperature gradients within the sphere are significant ( $Bi = 1$ ). At the curtailment of heating ( $Fo_1$ ), the surface temperature cools rapidly while warm temperatures continue to propagate toward the center, slowly heating the center until a steady-state, isothermal condition is eventually reached.

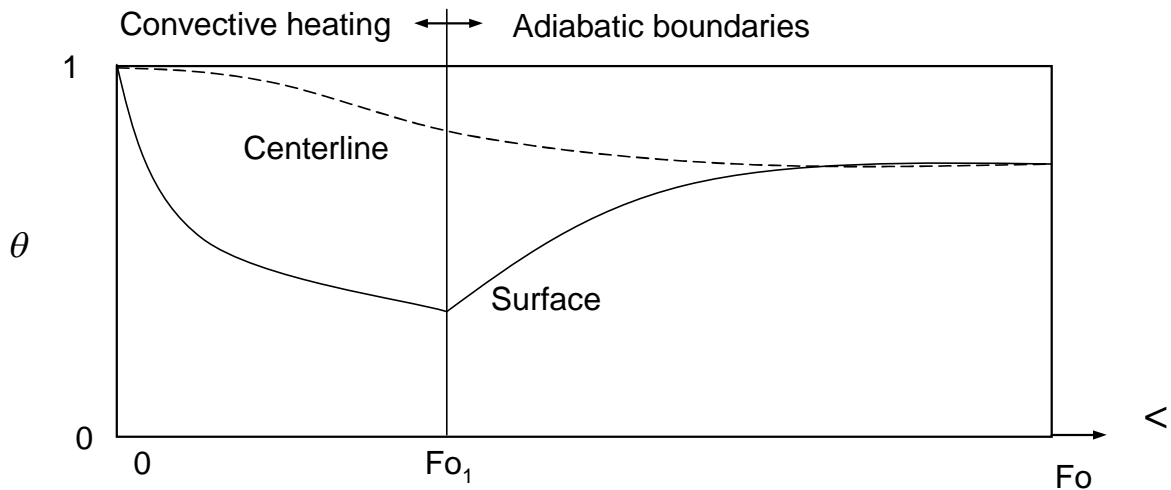

Based on the sketch above, one could achieve a steady-state center temperature equal to the center temperature at  $Fo_1$  by reducing the duration of convective heating to  $Fo_2$ , as shown in the sketch below.

Continued...

**PROBLEM 5.76 (Cont.)**

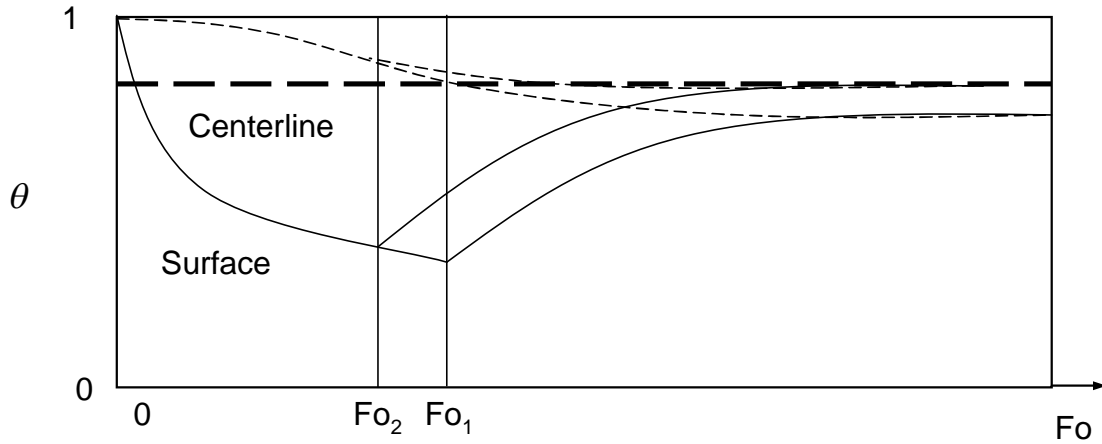

Hence,  $Fo_2 < Fo_1$ . <

(b) Using the approximate solutions of Sections 5.6.2 and 5.6.3, and noting that the steady-state temperature of the sphere is uniform and related to the energy transferred to the sphere,

$$\theta_o^*(Fo_1) = 1 - \frac{Q}{Q_o}(Fo_2)$$

or,

$$1 - \theta_o^*(Fo_1) = \frac{Q}{Q_o}(Fo_1 + \Delta Fo_1) \quad (1)$$

Substituting Eqs. 5.53c and 5.55 into Eq. (1) yields

$$1 - C_1 \exp(-\zeta_1^2 Fo_1) = 1 - \frac{3C_1 \exp(-\zeta_1^2 (Fo_1 + \Delta Fo))}{\zeta_1^3} [\sin(\zeta_1) - \zeta_1 \cos(\zeta_1)]$$

which may be simplified to

$$\Delta Fo = -\frac{1}{\zeta_1^2} \ln \left( \frac{\zeta_1^3}{3[\sin(\zeta_1) - \zeta_1 \cos(\zeta_1)]} \right) \quad <$$

From Table 5.1,  $\zeta_1 = 1.5708$  rad at  $Bi = 1$ . Hence,

$$\Delta Fo = -\frac{1}{1.5708^2} \ln \left( \frac{1.5708^3}{3[\sin(1.5708) - 1.5708 \cos(1.5708)]} \right) = -0.1038 \quad <$$

(c) The expression for  $\Delta Fo$  may be evaluated for a range of  $Bi$ , resulting in the following.

Continued...

**PROBLEM 5.76 (Cont.)**

$Bi$	$\zeta_1$	$\Delta Fo$	<
0.01	0.1730	-0.1000	
0.1	0.5423	-0.1004	
1	1.5708	-0.1038	
10	2.8363	-0.1154	
100	3.1102	-0.1200	
$\infty$	3.1415	-0.1207	

**COMMENTS:** (1) Note that the dimensionless temperature,  $\theta_o^* = C_1 \exp(-\zeta_1^2 Fo)$ , is defined in a manner such that for sphere heating, increases in actual temperature correspond to decreases in the dimensionless temperature. (2) The dimensionless time lag,  $\Delta Fo$ , is weakly-dependent on the value of the Biot number and is independent of the heating time. Hence, a general rule-of-thumb is that a time lag of  $\Delta Fo \approx -0.11$  should be specified in order to achieve an ultimate center temperature equal to that predicted at  $Fo_1$  for convective heating or cooling. (3) For applications such as materials or food processing, where a certain minimum center temperature is desired, assuming that  $Fo_1$  (as determined by Eq. 5.52c) is the appropriate processing or cooking time can result in significant over-heating of the material or food, especially at small Fourier numbers. (4) Significant energy and time savings can be realized by reducing the processing or cooking time from  $Fo_1$  to  $Fo_2$ .

### PROBLEM 5.77

**KNOWN:** Two spheres, A and B, initially at uniform temperatures of 800 K and simultaneously quenched in large, constant temperature baths each maintained at 320 K; properties of the spheres and convection coefficients.

**FIND:** (a) Show in a qualitative manner, on T-t coordinates, temperatures at the center and the outer surface for each sphere; explain features of the curves; (b) Time required for the outer surface of each sphere to reach 415 K, (c) Energy gained by each bath during process of cooling spheres to a surface temperature of 415 K.

**SCHEMATIC:**

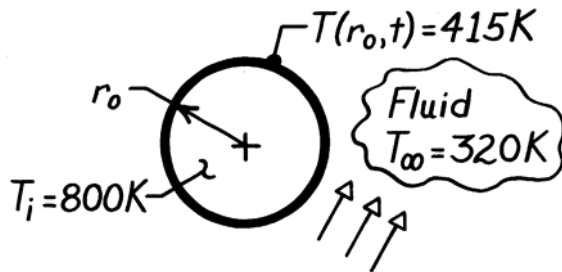

	Sphere A	Sphere B
$r_o$ (mm)	150	15
$\rho$ (kg/m <sup>3</sup> )	1600	400
$c$ (J/kg·K)	400	1600
$k$ (W/m·K)	170	1.7
$h$ (W/m <sup>2</sup> ·K)	5	50

**ASSUMPTIONS:** (1) One-dimensional radial conduction, (2) Uniform properties, (3) Constant convection coefficient.

**ANALYSIS:** (a) From knowledge of the Biot number and the thermal time constant, it is possible to qualitatively represent the temperature distributions. From Equation 5.10, with  $L_c = r_o/3$ , find

$$Bi_A = \frac{5 \text{ W/m}^2 \cdot \text{K} (0.150 \text{ m}/3)}{170 \text{ W/m} \cdot \text{K}} = 1.47 \times 10^{-3}$$

$$Bi = \frac{h(r_o/3)}{k}$$

$$Bi_B = \frac{50 \text{ W/m}^2 \cdot \text{K} (0.015 \text{ m}/3)}{1.7 \text{ W/m} \cdot \text{K}} = 0.147$$

The thermal time constant for a lumped capacitance system from Equation 5.7 is

$$\tau = \left[ \frac{1}{hA_s} \right] (\rho V c) \quad \tau_A = \frac{1600 \text{ kg/m}^3 \times (0.150 \text{ m})^3 \times 400 \text{ J/kg} \cdot \text{K}}{3 \times 5 \text{ W/m}^2 \cdot \text{K}} = 6400 \text{ s}$$

$$\tau = \frac{\rho r_o c}{3h} \quad \tau_B = \frac{400 \text{ kg/m}^3 \times (0.015 \text{ m}) \times 1600 \text{ J/kg} \cdot \text{K}}{3 \times 50 \text{ W/m}^2 \cdot \text{K}} = 64 \text{ s}$$

When  $Bi \ll 0.1$ , the sphere will cool in a spacewise isothermal manner (Sphere A). For sphere B,  $Bi > 0.1$ , hence gradients will be important. Note that the thermal time constant of A is much larger than for B; hence, A will cool much slower. See sketch for these features.

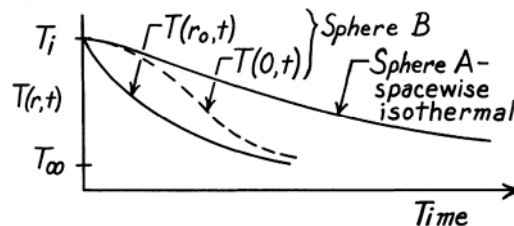

(b) Recognizing that  $Bi_A < 0.1$ , Sphere A can be treated as spacewise isothermal and analyzed using the lumped capacitance method. From Equation 5.6 and 5.7, with  $T = 415 \text{ K}$

$$\frac{\theta}{\theta_1} = \frac{T - T_\infty}{T_i - T_\infty} = \exp(-t/\tau)$$

Continued ...



**PROBLEM 5.77 (Cont.)**

$$t_A = -\tau_A \left[ \ln \frac{T - T_\infty}{T_i - T_\infty} \right] = -6400 \text{ s} \left[ \ln \frac{415 - 320}{800 - 320} \right] = 10,367 \text{ s} = 2.88 \text{ h.} \quad <$$

Note that since the sphere is nearly isothermal, the surface and inner temperatures are approximately the same.

Since  $Bi_B > 0.1$ , *Sphere B* must be treated by the exact method of solution. We assume that the one-term approximation is valid and check later. Hence, with

$$Bi_B = \frac{hr_o}{k} = \frac{50 \text{ W/m}^2 \cdot \text{K} (0.015 \text{ m})}{1.7 \text{ W/m} \cdot \text{K}} = 0.441$$

from Table 5.1,  $\zeta_1 = 1.0992$ ,  $C_1 = 1.1278$ . Then

$$\theta^*(r^* = 1, Fo) = \frac{T(r_o, t) - T_\infty}{T_i - T_\infty} = \frac{415^\circ\text{C} - 320^\circ\text{C}}{800^\circ\text{C} - 320^\circ\text{C}} = 0.1979$$

and Equation 5.53b can be solved for  $\theta_o^*$ :

$$\theta_o^* = \theta^* \zeta_1 r^* / \sin(\zeta_1 r^*) = 0.1979 \times 1.0992 \times 1 / \sin(1.0992) = 0.2442$$

Then Equation 5.53c can be solved for  $Fo$ :

$$Fo = -\frac{1}{\zeta_1^2} \ln(\theta_o^* / C_1) = -\frac{1}{1.0992^2} \ln(0.2442 / 1.1278) = 1.266$$

$$t_B = Fo \frac{r_o^2}{\alpha} = Fo \cdot \frac{\rho c_p}{k} \cdot r_o^2 = 1.266 \frac{400 \text{ kg/m}^3 \times 1600 \text{ J/kg} \cdot \text{K}}{1.7 \text{ W/m} \cdot \text{K}} \times (0.015 \text{ m})^2 = 107 \text{ s} <$$

Note that the one-term approximation is accurate, since  $Fo > 0.2$ .

(c) To determine the energy change by the spheres during the cooling process, apply the conservation of energy requirement on a time interval basis.

*Sphere A:*

$$E_{in} - E_{out} = \Delta E \quad -Q_A = \Delta E = E(t) - E(0).$$

$$Q_A = \rho cV [T(t) - T_i] = 1600 \text{ kg/m}^3 \times 400 \text{ J/kg} \cdot \text{K} \times (4/3)\pi (0.150 \text{ m})^3 [415 - 800] \text{ K}$$

$$Q_A = 3.483 \times 10^6 \text{ J.} \quad <$$

Note that this simple expression is a consequence of the spacewise isothermal behavior.

*Sphere B:*  $E_{in} - E_{out} = \Delta E \quad -Q_B = E(t) - E(0).$

For the nonisothermal sphere, Equation 5.55 can be used to evaluate  $Q_B$ .

$$\frac{Q_B}{Q_o} = 1 - \frac{3\theta_o^*}{\zeta_1^3} [\sin(\zeta_1) - \zeta_1 \cos(\zeta_1)] = 1 - \frac{3 \times 0.2442}{1.0992^3} [\sin(1.0992) - 1.0992 \cos(1.0992)] = 0.784$$

The energy transfer from the sphere during the cooling process, using Equation 5.47, is

$$Q_B = 0.784 Q_o = 0.784 [\rho cV (T_i - T_\infty)]$$

$$Q_B = 0.784 \times 400 \text{ kg/m}^3 \times 1600 \text{ J/kg} \cdot \text{K} (4/3)\pi (0.015 \text{ m})^3 (800 - 320) \text{ K} = 3405 \text{ J} \quad <$$

**COMMENTS:** In summary:

Sphere	$Bi = hr_o/k$	$\tau$ (s)	t(s)	Q(J)
A	$4.41 \times 10^3$	6400	10,370	$3.48 \times 10^6$
B	0.44	64	107	3405

### PROBLEM 5.78

**KNOWN:** Spheres of 40-mm diameter heated to a uniform temperature of 400°C are suddenly removed from an oven and placed in a forced-air bath operating at 25°C with a convection coefficient of 300 W/m<sup>2</sup>·K.

**FIND:** (a) Time the spheres must remain in the bath for 80% of the thermal energy to be removed, and (b) Uniform temperature the spheres will reach when removed from the bath at this condition and placed in a carton that prevents further heat loss.

**SCHEMATIC:**

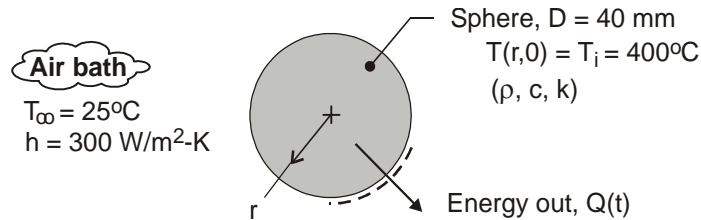

**ASSUMPTIONS:** (1) One-dimensional radial conduction in the spheres, (2) Constant properties, and (3) No heat loss from sphere after removed from the bath and placed into the packing carton.

**PROPERTIES:** Sphere (*given*):  $\rho = 3000 \text{ kg/m}^3$ ,  $c = 850 \text{ J/kg}\cdot\text{K}$ ,  $k = 15 \text{ W/m}\cdot\text{K}$ .

**ANALYSIS:** (a) From Eq. 5.55, the fraction of thermal energy removed during the time interval  $\Delta t = t_0$  is

$$\frac{Q}{Q_0} = 1 - 3\theta_0^* / \zeta_1^3 [\sin(\zeta_1) - \zeta_1 \cos(\zeta_1)] \quad (1)$$

where  $Q/Q_0 = 0.8$ . The Biot number is

$$Bi = hr_0 / k = 300 \text{ W/m}^2 \cdot \text{K} \times 0.020 \text{ m} / 15 \text{ W/m} \cdot \text{K} = 0.40$$

and for the one-term series approximation, from Table 5.1,

$$\zeta_1 = 1.0528 \text{ rad} \quad C_1 = 1.1164 \quad (2)$$

The dimensionless temperature  $\theta_0^*$ , follows from Eq. 5.53b.

$$\theta_0^* = C_1 \exp(-\zeta_1^2 Fo) \quad (3)$$

where  $Fo = \alpha t_0 / r_0^2$ . Substituting Eq. (3) into Eq. (1), solve for  $Fo$  and  $t_0$ .

$$\frac{Q}{Q_0} = 1 - 3 C_1 \exp(-\zeta_1^2 Fo) / \zeta_1^3 [\sin(\zeta_1) - \zeta_1 \cos(\zeta_1)] \quad (4)$$

$$Fo = 1.45 \quad t_0 = 98.6 \text{ s} \quad <$$

(b) Performing an overall energy balance on the sphere during the interval of time  $t_0 \leq t \leq \infty$ ,

$$E_{in} - E_{out} = \Delta E = E_f - E_i = 0 \quad (5)$$

where  $E_i$  represents the thermal energy in the sphere at  $t_0$ ,

$$E_i = (1 - 0.8)Q_0 = (1 - 0.8)\rho cV(T_i - T_\infty) \quad (6)$$

and  $E_f$  represents the thermal energy in the sphere at  $t = \infty$ ,

$$E_f = \rho cV(T_{avg} - T_\infty) \quad (7)$$

Combining the relations, find the average temperature

$$\rho cV[(T_{avg} - T_\infty) - (1 - 0.8)(T_i - T_\infty)] = 0$$

$$T_{avg} = 100^\circ\text{C} \quad <$$

### PROBLEM 5.79

**KNOWN:** Dimensions and initial temperature of spider brain and cephalothorax. Ambient temperature and heat transfer coefficient.

**FIND:** Time required for brain to begin freezing.

**SCHEMATIC:**

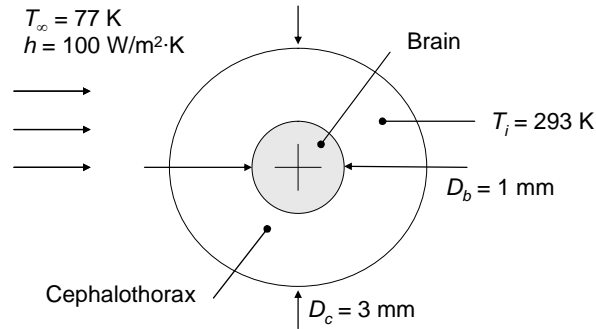

**ASSUMPTIONS:** (1) Constant properties. (2) Negligible effect of ice formation.

**PROPERTIES:** Table A.6, water ( $T = 283 \text{ K}$ ):  $\rho = 1000 \text{ kg/m}^3$ ,  $c = 4193 \text{ J/kg}\cdot\text{K}$ , and  $k = 0.587 \text{ W/m}\cdot\text{K}$ .

**ANALYSIS:** To determine whether spatial effects are important, the Biot number is calculated in the conservative fashion

$$Bi = \frac{hr_o}{k} = \frac{hD_c}{2k} = \frac{100 \text{ W/m}^2 \cdot \text{K} \times 3 \times 10^{-3} \text{ m}}{2 \times 0.587 \text{ W/m} \cdot \text{K}} = 0.25$$

Spatial effects are important and the lumped capacitance approximation is not valid. From Table 5.1  $\zeta_1 = 0.8447$ ,  $C_1 = 1.0737$ . The brain begins to freeze when the temperature at  $D_b = 1 \text{ mm}$  reaches the freezing temperature,  $T = 0^\circ\text{C}$ .

Assuming validity of the approximate solution, Equation 5.53a may be rearranged to yield

$$Fo = -\frac{1}{\zeta_1^2} \ln \left( \frac{\theta^* \zeta_1 r^*}{C_1 \sin(\zeta_1 r^*)} \right)$$

where 
$$\theta^* = \frac{T - T_\infty}{T_i - T_\infty} = \frac{273 \text{ K} - 77 \text{ K}}{293 \text{ K} - 77 \text{ K}} = 0.907 \quad \text{and} \quad r^* = \frac{D_b}{D_c} = \frac{1 \text{ mm}}{3 \text{ mm}} = 1/3$$

Hence

$$Fo = \frac{\alpha t}{(D_c/2)^2} = \frac{1}{0.8447^2} \ln \left( \frac{0.907 \times 0.8447/3}{1.0737 \sin(0.8447/3)} \right) = 0.22$$

Continued...

**PROBLEM 5.79 (Cont.)**

Since  $Fo > 0.2$  the approximate solution is valid and the time required for the brain to begin to freeze is

$$t = \frac{Fo\rho c(D_c/2)^2}{k} = \frac{0.22 \times 1000 \text{ kg/m}^3 \times 4193 \text{ J/kg} \cdot \text{K} \times (3 \times 10^{-3} \text{ m}/2)^2}{0.587 \text{ W/m} \cdot \text{K}} = 3.5 \text{ s} <$$

**COMMENTS:** (1) Solidification of the cephalothorax shell will lengthen the time needed to freeze the spider's brain. (2) The spider's brain begins to freeze 3.5 seconds after being exposed to the liquid nitrogen. It may be the case that the spider no longer remembers the frightening scene in the video when its brain freezes.

### PROBLEM 5.80

**KNOWN:** Diameter, density, specific heat and thermal conductivity of Pyrex spheres in packed bed thermal energy storage system. Convection coefficient and inlet gas temperature.

**FIND:** Time required for sphere to acquire 90% of maximum possible thermal energy and the corresponding center temperature.

**SCHEMATIC:**

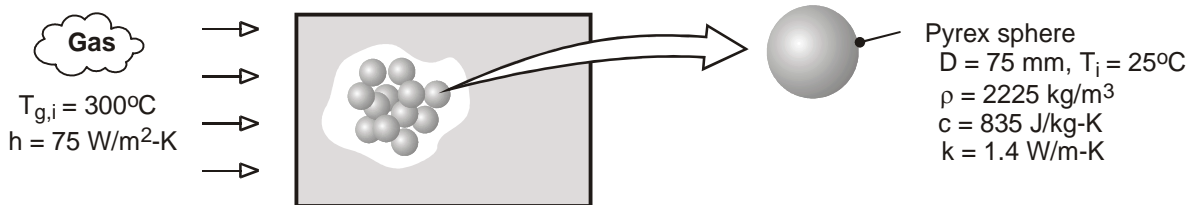

**ASSUMPTIONS:** (1) One-dimensional radial conduction in sphere, (2) Negligible heat transfer to or from a sphere by radiation or conduction due to contact with adjoining spheres, (3) Constant properties.

**ANALYSIS:** With  $Bi \equiv h(r_o/3)/k = 75 \text{ W/m}^2 \cdot \text{K} (0.0125\text{m})/1.4 \text{ W/m} \cdot \text{K} = 0.67$ , the approximate solution for one-dimensional transient conduction in a sphere is used to obtain the desired results. We first use Eq. (5.55) to obtain  $\theta_o^*$ .

$$\theta_o^* = \frac{\zeta_1^3}{3[\sin(\zeta_1) - \zeta_1 \cos(\zeta_1)]} \left(1 - \frac{Q}{Q_o}\right)$$

With  $Bi \equiv hr_o/k = 2.01$ ,  $\zeta_1 \approx 2.03$  and  $C_1 \approx 1.48$  from Table 5.1. Hence,

$$\theta_o^* = \frac{0.1(2.03)^3}{3[0.896 - 2.03(-0.443)]} = \frac{0.837}{5.386} = 0.155$$

The center temperature is therefore

$$T_o = T_{g,i} + 0.155(T_i - T_{g,i}) = 300^\circ\text{C} - 42.7^\circ\text{C} = 257.3^\circ\text{C} \quad <$$

From Eq. (5.53c), the corresponding time is

$$t = -\frac{r_o^2}{\alpha \zeta_1^2} \ln\left(\frac{\theta_o^*}{C_1}\right)$$

where  $\alpha = k / \rho c = 1.4 \text{ W/m} \cdot \text{K} / (2225 \text{ kg/m}^3 \times 835 \text{ J/kg} \cdot \text{K}) = 7.54 \times 10^{-7} \text{ m}^2/\text{s}$ .

$$t = -\frac{(0.0375\text{m})^2 \ln(0.155/1.48)}{7.54 \times 10^{-7} \text{ m}^2/\text{s} (2.03)^2} = 1,020\text{s} \quad <$$

**COMMENTS:** The surface temperature at the time of interest may be obtained from Eq. (5.53b).

With  $r^* = 1$ ,

$$T_s = T_{g,i} + (T_i - T_{g,i}) \frac{\theta_o^* \sin(\zeta_1)}{\zeta_1} = 300^\circ\text{C} - 275^\circ\text{C} \left(\frac{0.155 \times 0.896}{2.03}\right) = 280.9^\circ\text{C} \quad <$$

### PROBLEM 5.81

**KNOWN:** Initial temperature and properties of a solid sphere. Surface temperature after immersion in a fluid of prescribed temperature and convection coefficient.

**FIND:** (a) Time to reach surface temperature, (b) Effect of thermal diffusivity and conductivity on thermal response.

**SCHEMATIC:**

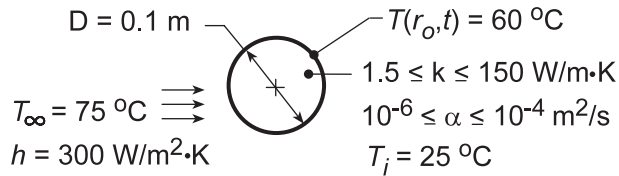

**ASSUMPTIONS:** (1) One-dimensional, radial conduction, (2) Constant properties.

**ANALYSIS:** (a) For  $k = 15 \text{ W/m}\cdot\text{K}$ , the Biot number is

$$Bi = \frac{h(r_o/3)}{k} = \frac{300 \text{ W/m}^2 \cdot \text{K}(0.05 \text{ m}/3)}{15 \text{ W/m}\cdot\text{K}} = 0.333.$$

Hence, the lumped capacitance method cannot be used. From Equation 5.53a,

$$\frac{T - T_\infty}{T_i - T_\infty} = C_1 \exp(-\zeta_1^2 Fo) \frac{\sin(\zeta_1 r^*)}{\zeta_1 r^*}.$$

At the surface,  $r^* = 1$ . From Table 5.1, for  $Bi = 1.0$ ,  $\zeta_1 = 1.5708 \text{ rad}$  and  $C_1 = 1.2732$ . Hence,

$$\frac{60 - 75}{25 - 75} = 0.30 = 1.2732 \exp(-1.5708^2 Fo) \frac{\sin 90^\circ}{1.5708}$$

$$\exp(-2.467Fo) = 0.370$$

$$Fo = \frac{\alpha t}{r_o^2} = 0.403$$

$$t = 0.403 \frac{r_o^2}{\alpha} = 0.403 \frac{(0.05 \text{ m})^2}{10^{-5} \text{ m}^2/\text{s}} = 100\text{s} \quad <$$

(b) Using the IHT *Transient Conduction Model* for a *Sphere* to perform the parametric calculations, the effect of  $\alpha$  is plotted for  $k = 15 \text{ W/m}\cdot\text{K}$ .

Continued...

### PROBLEM 5.81 (Cont.)

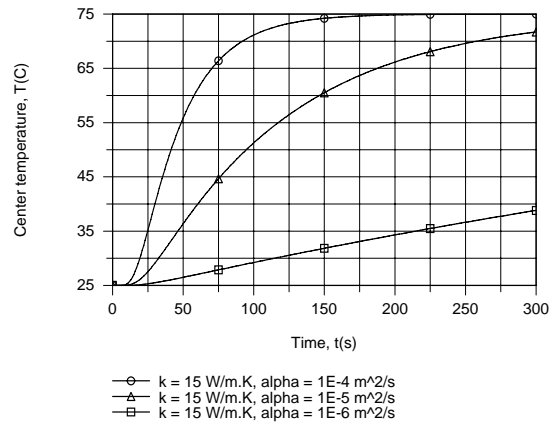
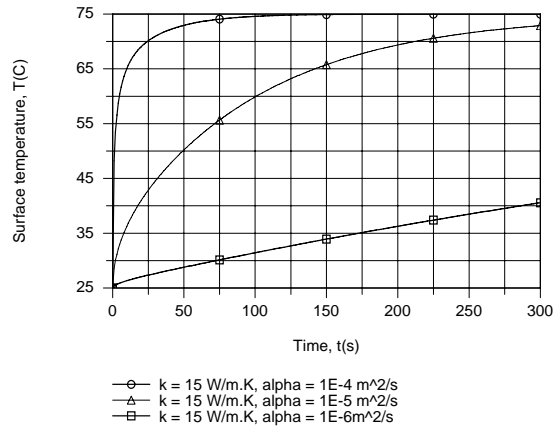

For fixed  $k$  and increasing  $\alpha$ , there is a reduction in the thermal capacity ( $\rho c_p$ ) of the material, and hence the amount of thermal energy which must be added to increase the temperature. With increasing  $\alpha$ , the material therefore responds more quickly to a change in the thermal environment, with the response at the center lagging that of the surface.

The effect of  $k$  is plotted for  $\alpha = 10^{-5} \text{ m}^2/\text{s}$ .

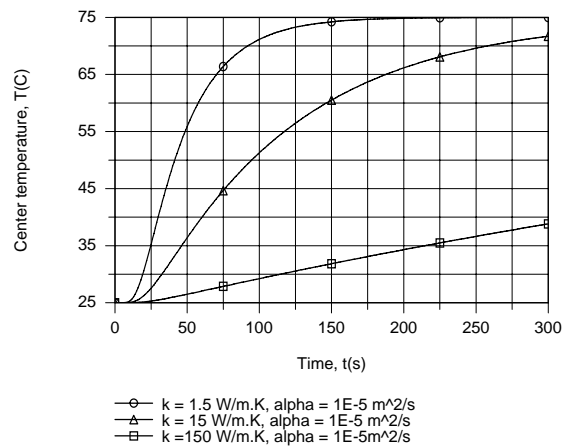
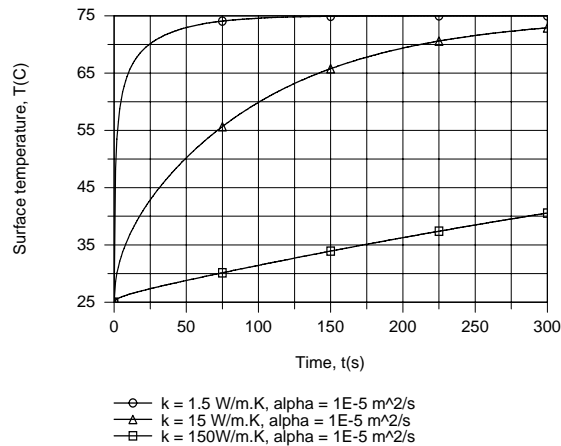

With increasing  $k$  for fixed  $\alpha$ , there is a corresponding increase in  $\rho c_p$ , and the material therefore responds more slowly to a thermal change in its surroundings. The thermal response of the center lags that of the surface, with temperature differences,  $T(r_o, t) - T(0, t)$ , during early stages of solidification increasing with decreasing  $k$ .

**COMMENTS:** Use of this technique to determine  $h$  from measurement of  $T(r_o)$  at a prescribed  $t$  requires an iterative solution of the governing equations.

## PROBLEM 5.82

**KNOWN:** Temperature requirements for cooling the spherical material of Example 5.6 in air and in a water bath.

**FIND:** (a) For step 1, the time required for the center temperature to reach  $T(0,t) = 335^\circ\text{C}$  while cooling in air at  $20^\circ\text{C}$  with  $h = 10 \text{ W/m}^2\cdot\text{K}$ ; find the Biot number; do you expect radial gradients to be appreciable?; compare results with hand calculations in Example 5.6; (b) For step 2, time required for the center temperature to reach  $T(0,t) = 50^\circ\text{C}$  while cooling in water bath at  $20^\circ\text{C}$  with  $h = 6000 \text{ W/m}^2\cdot\text{K}$ ; and (c) For step 2, calculate and plot the temperature history,  $T(x,t)$  vs.  $t$ , for the center and surface of the sphere; explain features; when do you expect the temperature gradients in the sphere to be the largest? Use the IHT Models / Transient Conduction / Sphere model as your solution tool.

**SCHEMATIC:**

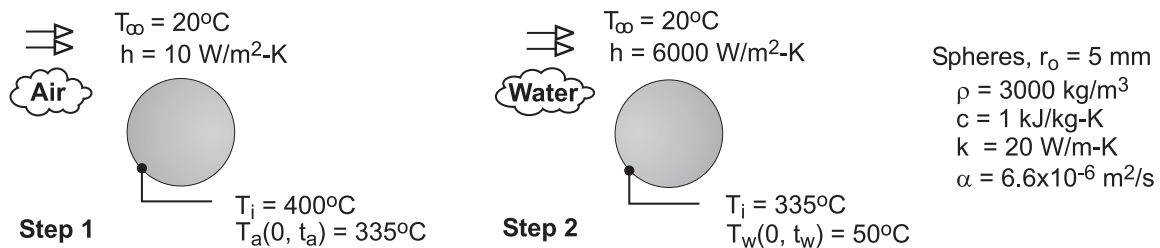

**ASSUMPTIONS:** (1) One-dimensional conduction in the radial direction, (2) Constant properties.

**ANALYSIS:** The IHT model represents the series solution for the sphere providing the temperatures evaluated at  $(r,t)$ . A selected portion of the IHT code used to obtain results is shown in the Comments.

(a) Using the IHT model with step 1 conditions, the time required for  $T(0,t_a) = T_{xt} = 335^\circ\text{C}$  with  $r = 0$  and the Biot number are:

$$t_a = 94.2 \text{ s} \qquad \text{Bi} = 0.0025 \qquad <$$

Radial temperature gradients will not be appreciable since  $\text{Bi} = 0.0025 \ll 0.1$ . The sphere behaves as space-wise isothermal object for the air-cooling process. The result is identical to the lumped-capacitance analysis result of the Text example.

(b) Using the IHT model with step 2 conditions, the time required for  $T(0,t_w) = T_{xt} = 50^\circ\text{C}$  with  $r = 0$  and  $T_i = 335^\circ\text{C}$  is

$$t_w = 3.0 \text{ s} \qquad <$$

Radial temperature gradients will be appreciable, since  $\text{Bi} = 1.5 \gg 0.1$ . The sphere does not behave as a space-wise isothermal object for the water-cooling process.

(c) For the step 2 cooling process, the temperature histories for the center and surface of the sphere are calculated using the IHT model.

Continued ...



## PROBLEM 5.82 (Cont.)

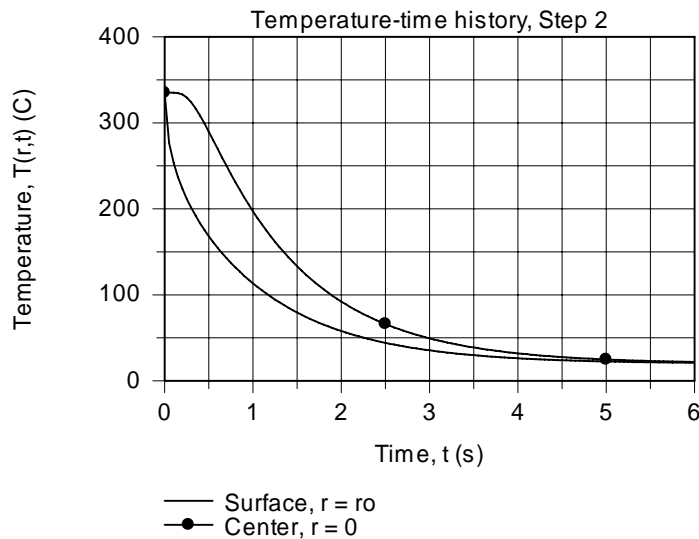

At early times, the difference between the center and surface temperature is appreciable. It is in this time region that thermal stresses will be a maximum, and if large enough, can cause fracture. Within 6 seconds, the sphere has a uniform temperature equal to that of the water bath.

**COMMENTS:** Selected portions of the IHT sphere model codes for steps 1 and 2 are shown below.

```

/* Results, for part (a), step 1, air cooling; clearly negligible gradient
Bi      Fo      t      T_xt      Ti      r      ro
0.0025  25.13   94.22   335      400     0      0.005 */

```

```

// Models | Transient Conduction | Sphere - Step 1, Air cooling
// The temperature distribution T(r,t) is
T_xt = T_xt_trans("Sphere",rstar,Fo,Bi,Ti,Tinf) //
T_xt = 335 // Surface temperature

```

```

/* Results, for part (b), step 2, water cooling; Ti = 335 C
Bi      Fo      t      T_xt      Ti      r      ro
1.5     0.7936  2.976   50        335     0      0.005 */

```

```

// Models | Transient Conduction | Sphere - Step 2, Water cooling
// The temperature distribution T(r,t) is
T_xt = T_xt_trans("Sphere",rstar,Fo,Bi,Ti,Tinf) //
//T_xt = 335 // Surface temperature from Step 1; initial temperature for Step 2
T_xt = 50 // Center temperature, end of Step 2

```

### PROBLEM 5.83

**KNOWN:** Two large blocks of different materials – like copper and concrete – at room temperature, 23°C.

**FIND:** Which block will feel cooler to the touch?

**SCHEMATIC:**

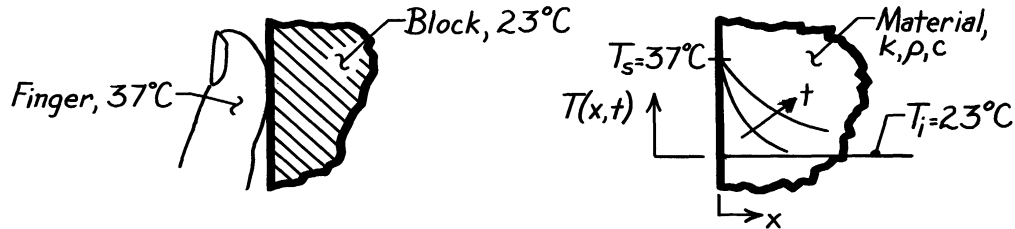

**ASSUMPTIONS:** (1) Blocks can be treated as semi-infinite solid, (2) Hand or finger temperature is 37°C.

**PROPERTIES:** Table A-1, Copper (300K):  $\rho = 8933 \text{ kg/m}^3$ ,  $c = 385 \text{ J/kg}\cdot\text{K}$ ,  $k = 401 \text{ W/m}\cdot\text{K}$ ; Table A-3, Concrete, stone mix (300K):  $\rho = 2300 \text{ kg/m}^3$ ,  $c = 880 \text{ J/kg}\cdot\text{K}$ ,  $k = 1.4 \text{ W/m}\cdot\text{K}$ .

**ANALYSIS:** Considering the block as a semi-infinite solid, the heat transfer situation corresponds to a sudden change in surface temperature, Case 1, Figure 5.7. The sensation of coolness is related to the heat flow from the hand or finger to the block. From Eq. 5.61, the surface heat flux is

$$q_s''(t) = k(T_s - T_i) / (\pi \alpha t)^{1/2} \quad (1)$$

or

$$q_s''(t) \sim (k\rho c)^{1/2} \quad \text{since} \quad \alpha = k/\rho c. \quad (2)$$

Hence for the same temperature difference,  $T_s - T_i$ , and elapsed time, it follows that the heat fluxes for the two materials are related as

$$\frac{q_{s,\text{copper}}''}{q_{s,\text{concrete}}''} = \frac{(k\rho c)_{\text{copper}}^{1/2}}{(k\rho c)_{\text{concrete}}^{1/2}} = \frac{\left[ 401 \frac{\text{W}}{\text{m}\cdot\text{K}} \times 8933 \frac{\text{kg}}{\text{m}^3} \times 385 \frac{\text{J}}{\text{kg}\cdot\text{K}} \right]^{1/2}}{\left[ 1.4 \frac{\text{W}}{\text{m}\cdot\text{K}} \times 2300 \frac{\text{kg}}{\text{m}^3} \times 880 \frac{\text{J}}{\text{kg}\cdot\text{K}} \right]^{1/2}} = 22.1$$

Hence, the heat flux to the copper block is more than 20 times larger than to the concrete block. The *copper* block will therefore feel noticeably cooler than the concrete one.

### PROBLEM 5.84

**KNOWN:** Thickness and properties of plane wall. Convection coefficient.

**FIND:** (a) Nondimensional temperature for six different cases using four methods and (b) Explain the conditions for which the three approximate methods are good approximations of the exact solution.

**SCHEMATIC:**

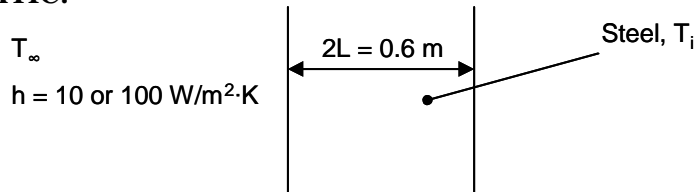

**ASSUMPTIONS:** (1) Constant properties.

**PROPERTIES:** Steel (given):  $k = 30 \text{ W/m}\cdot\text{K}$ ,  $\rho = 7900 \text{ kg/m}^3$ ,  $c = 640 \text{ J/kg}\cdot\text{K}$ .

**ANALYSIS:**

(a) We perform the calculations for  $h = 10 \text{ W/m}^2\cdot\text{K}$ ,  $t = 2.5 \text{ min}$ .

Exact Solution

From Equation 5.42a, evaluated at the surface  $x^* = 1$ ,

$$\theta_s^* = \frac{T_s - T_\infty}{T_i - T_\infty} = \sum_{n=1}^{\infty} C_n \exp(-\zeta_n^2 \text{Fo}) \cos(\zeta_n)$$

For  $t = 2.5 \text{ min}$ ,

$$\begin{aligned} \text{Fo} &= \frac{\alpha t}{L^2} = \frac{k}{\rho c} \frac{t}{L^2} \\ &= \frac{30 \text{ W/m}\cdot\text{K}}{7900 \frac{\text{kg}}{\text{m}^3} \times 640 \frac{\text{J}}{\text{kg}\cdot\text{K}}} \times \frac{(2.5 \times 60) \text{ s}}{(0.3 \text{ m})^2} = 0.0099 \end{aligned}$$

We also calculate  $\text{Bi} = hL/k = 10 \text{ W/m}^2\cdot\text{K} \times 0.3 \text{ m}/30 \text{ W/m}\cdot\text{K} = 0.10$ . The first four values of  $\zeta_n$  are found in Table B.3, and the corresponding values of  $C_n$  can be calculated from Equation 5.39b,  $C_n = 4 \sin \zeta_n / [2\zeta_n + \sin(2\zeta_n)]$ . Then the first four terms in Equation 5.42a can be calculated as well. The results are tabulated below.

n	$\zeta_n$	$C_n$	$C_n \exp(-\zeta_n^2 \text{Fo}) \cos(\zeta_n)$
1	0.3111	1.016	0.9664
2	3.1731	-0.0197	0.0178
3	6.2991	0.0050	0.0034
4	9.4354	-0.0022	<u>0.0009</u>
			$\theta_s^* = 0.989$

Continued...

### PROBLEM 5.84 (Cont.)

We can see that the fourth term is small, so to a good approximation the exact solution can be found by summing the first four terms, as shown in the table. Thus

$$\theta_{s,\text{exact}}^* = 0.989 \quad \leftarrow$$

#### First Term

From the above table,

$$\theta_{s,1\text{-term}}^* = 0.966 \quad \leftarrow$$

#### Lumped Capacitance

From Equation 5.6,

$$\begin{aligned} \theta_{\text{lump}}^* &= \exp\left[-\frac{hA_s}{\rho V c} t\right] = \exp\left[-\frac{ht}{\rho Lc}\right] \\ &= \exp\left[-\frac{10 \text{ W/m}^2 \cdot \text{K} \times (2.5 \times 60) \text{ s}}{7900 \text{ kg/m}^3 \times 0.3 \text{ m} \times 640 \text{ J/kg} \cdot \text{K}}\right] = 0.999 \end{aligned}$$

#### Semi-Infinite Solid

We use Equation 5.63 with  $x$  measured from the surface, that is  $x = 0$ .

$$\begin{aligned} \theta_{s,\text{semi}}^* &= \frac{T_s - T_\infty}{T_i - T_\infty} = 1 - \frac{T_s - T_i}{T_\infty - T_i} \\ &= 1 - \text{erfc}(0) + \exp\left(\frac{h^2 \alpha t}{k^2}\right) \text{erfc}\left(\frac{h\sqrt{\alpha t}}{k}\right) \\ &= 1 - 1 + \exp(\text{Bi}^2 \text{Fo}) \text{erfc}(\text{Bi} \text{Fo}^{1/2}) \\ &= \exp(0.10^2 \times 0.0099) \text{erfc}(0.10 \times (0.0099)^{1/2}) \\ &= 1.0001 \times 0.989 = 0.989 \quad \leftarrow \end{aligned}$$

where the error function was evaluated from Table B.2.

Repeating the calculation for the other five cases, the following table can be compiled:

Method	$Bi = 0.1$			$Bi = 1$		
	$Fo = 0.01$	$Fo = 0.1$	$Fo = 1.0$	$Fo = 0.01$	$Fo = 0.1$	$Fo = 1.0$
Exact	0.99	0.97	0.88	0.90	0.72	0.35
First-term	0.97	0.96	0.88	0.72	0.68	0.35
Lumped	1.00	0.99	0.90	0.99	0.90	0.37
Semi-inf.	0.99	0.97	0.90	0.90	0.72	0.43

(b) (i) The first term solution is a good approximation to the exact solution for  $Fo > 0.2$ . As seen in the above table, for  $Fo = 1.0$ , the first term solution is correct to two significant digits.

Continued...

### **PROBLEM 5.84 (Cont.)**

(ii) The lumped capacitance solution is a good approximation to the exact solution for  $Bi < 0.1$ . In the above table, the lumped capacitance solution is quite accurate for  $Bi = 0.1$ , but not for  $Bi = 1.0$ .

(iii) The semi-infinite solid solution is a good approximation to the exact solution for the smaller values of Fourier, since for small  $t$  or  $\alpha$ , or for large  $L$ , the heat doesn't penetrate through the wall and it can be treated as semi-infinite.

### PROBLEM 5.85

**KNOWN:** Asphalt pavement, initially at 50°C, is suddenly exposed to a rainstorm reducing the surface temperature to 20°C.

**FIND:** Total amount of energy removed ( $\text{J/m}^2$ ) from the pavement for a 30 minute period.

**SCHEMATIC:**

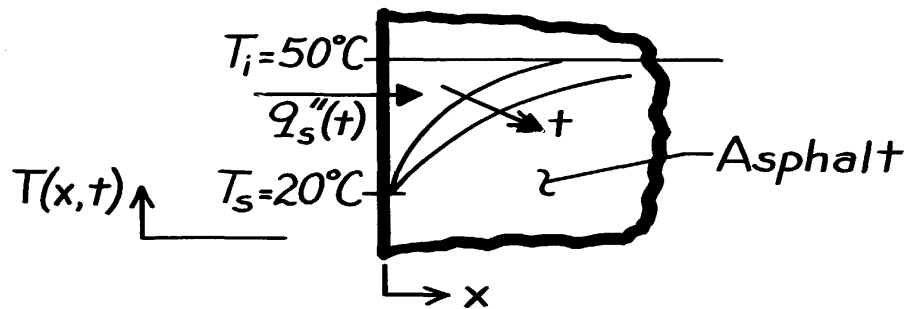

**ASSUMPTIONS:** (1) Asphalt pavement can be treated as a semi-infinite solid, (2) Effect of rainstorm is to suddenly reduce the surface temperature to 20°C and is maintained at that level for the period of interest.

**PROPERTIES:** Table A-3, Asphalt (300K):  $\rho = 2115 \text{ kg/m}^3$ ,  $c = 920 \text{ J/kg}\cdot\text{K}$ ,  $k = 0.062 \text{ W/m}\cdot\text{K}$ .

**ANALYSIS:** This solution corresponds to Case 1, Figure 5.7, and the surface heat flux is given by Eq. 5.61 as

$$q_s''(t) = k(T_s - T_i) / (\pi\alpha t)^{1/2} \quad (1)$$

The energy into the pavement over a period of time is the integral of the surface heat flux expressed as

$$Q'' = \int_0^t q_s''(t) dt. \quad (2)$$

Note that  $q_s''(t)$  is into the solid and, hence,  $Q$  represents energy into the solid. Substituting Eq. (1) for  $q_s''(t)$  into Eq. (2) and integrating find

$$Q'' = k(T_s - T_i) / (\pi\alpha)^{1/2} \int_0^t t^{-1/2} dt = \frac{k(T_s - T_i)}{(\pi\alpha)^{1/2}} \times 2 t^{1/2}. \quad (3)$$

Substituting numerical values into Eq. (3) with

$$\alpha = \frac{k}{\rho c} = \frac{0.062 \text{ W/m}\cdot\text{K}}{2115 \text{ kg/m}^3 \times 920 \text{ J/kg}\cdot\text{K}} = 3.18 \times 10^{-8} \text{ m}^2/\text{s}$$

find that for the 30 minute period,

$$Q'' = \frac{0.062 \text{ W/m}\cdot\text{K} (20 - 50) \text{ K}}{(\pi \times 3.18 \times 10^{-8} \text{ m}^2/\text{s})^{1/2}} \times 2(30 \times 60 \text{ s})^{1/2} = -4.99 \times 10^5 \text{ J/m}^2. \quad <$$

**COMMENTS:** Note that the sign for  $Q''$  is negative implying that energy is removed from the solid.

### PROBLEM 5.86

**KNOWN:** Thermophysical properties and initial temperature of thick steel plate. Temperature of water jets used for convection cooling at one surface.

**FIND:** Time required to cool prescribed interior location to a prescribed temperature.

**SCHEMATIC:**

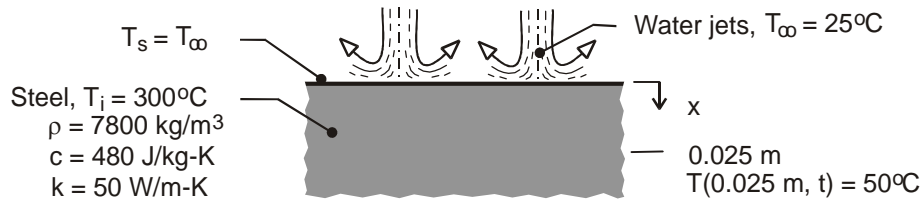

**ASSUMPTIONS:** (1) One-dimensional conduction in slab, (2) Validity of semi-infinite medium approximation, (3) Negligible thermal resistance between water jets and slab surface (\$T\_s = T\_\infty\$), (4) Constant properties.

**ANALYSIS:** The desired cooling time may be obtained from Eq. (5.60). With \$T(0.025\text{m}, t) = 50^\circ\text{C}\$,

$$\frac{T(x, t) - T_s}{T_i - T_s} = \frac{(50 - 25)^\circ\text{C}}{(300 - 25)^\circ\text{C}} = 0.0909 = \text{erf}\left(\frac{x}{2\sqrt{\alpha t}}\right)$$

$$\frac{x}{2\sqrt{\alpha t}} = 0.0807$$

$$t = \frac{x^2}{(0.0807)^2 4\alpha} = \frac{(0.025\text{m})^2}{0.0261(1.34 \times 10^{-5} \text{m}^2/\text{s})} = 1793\text{s} \quad <$$

where \$\alpha = k/\rho c = 50 \text{ W/m}\cdot\text{K}/(7800 \text{ kg/m}^3 \times 480 \text{ J/kg}\cdot\text{K}) = 1.34 \times 10^{-5} \text{ m}^2/\text{s}\$.

**COMMENTS:** (1) Large values of the convection coefficient (\$h \sim 10^4 \text{ W/m}^2\cdot\text{K}\$) are associated with water jet impingement, and it is reasonable to assume that the surface is immediately quenched to the temperature of the water. (2) The surface heat flux may be determined from Eq. (5.61). In principle, the flux is infinite at \$t = 0\$ and decays as \$t^{1/2}\$.

### PROBLEM 5.87

**KNOWN:** Tile-iron, 254 mm to a side, at 150°C is suddenly brought into contact with tile over a subflooring material initially at  $T_i = 25^\circ\text{C}$  with prescribed thermophysical properties. Tile adhesive softens in 2 minutes at 50°C, but deteriorates above 120°C.

**FIND:** (a) Time required to lift a tile after being heated by the tile-iron and whether adhesive temperature exceeds 120°C, (2) How much energy has been removed from the tile-iron during the time it has taken to lift the tile.

**SCHEMATIC:**

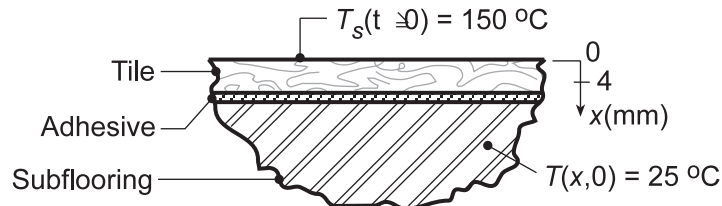

**ASSUMPTIONS:** (1) Tile and subflooring have same thermophysical properties, (2) Thickness of adhesive is negligible compared to that of tile, (3) Tile-subflooring behaves as semi-infinite solid experiencing one-dimensional transient conduction.

**PROPERTIES:** Tile-subflooring (given):  $k = 0.15 \text{ W/m}\cdot\text{K}$ ,  $\rho c_p = 1.5 \times 10^6 \text{ J/m}^3\cdot\text{K}$ ,  $\alpha = k/\rho c_p = 1.00 \times 10^{-7} \text{ m}^2/\text{s}$ .

**ANALYSIS:** (a) The tile-subflooring can be approximated as a semi-infinite solid, initially at a uniform temperature  $T_i = 25^\circ\text{C}$ , experiencing a sudden change in surface temperature  $T_s = T(0,t) = 150^\circ\text{C}$ . This corresponds to Case 1, Figure 5.7. The time required to heat the adhesive ( $x_o = 4 \text{ mm}$ ) to  $50^\circ\text{C}$  follows from Eq. 5.60

$$\frac{T(x_o, t_o) - T_s}{T_i - T_s} = \text{erf} \left( \frac{x_o}{2(\alpha t_o)^{1/2}} \right)$$

$$\frac{50 - 150}{25 - 150} = \text{erf} \left( \frac{0.004 \text{ m}}{2(1.00 \times 10^{-7} \text{ m}^2/\text{s} \times t_o)^{1/2}} \right)$$

$$0.80 = \text{erf} \left( 6.325 t_o^{-1/2} \right)$$

$$t_o = 48.7 \text{ s} = 0.81 \text{ min}$$

using error function values from Table B.2. Since the softening time,  $\Delta t_s$ , for the adhesive is 2 minutes, the time to lift the tile is

$$t_\ell = t_o + \Delta t_s = (0.81 + 2.0) \text{ min} = 2.81 \text{ min} .$$

To determine whether the adhesive temperature has exceeded  $120^\circ\text{C}$ , calculate its temperature at  $t_\ell = 2.81 \text{ min}$ ; that is, find  $T(x_o, t_\ell)$

$$\frac{T(x_o, t_\ell) - 150}{25 - 150} = \text{erf} \left( \frac{0.004 \text{ m}}{2(1.0 \times 10^{-7} \text{ m}^2/\text{s} \times 2.81 \times 60 \text{ s})^{1/2}} \right)$$

Continued...



### PROBLEM 5.87 (Cont.)

$$T(x_o, t_\ell) - 150 = -125 \operatorname{erf}(0.4880) = -125 \times 0.5098$$

$$T(x_o, t_\ell) = 86^\circ\text{C}$$

&lt;

Since  $T(x_o, t_\ell) < 120^\circ\text{C}$ , the adhesive will not deteriorate.

(b) The energy required to heat a tile to the lift-off condition is

$$Q = \int_0^{t_\ell} q_x''(0, t) \cdot A_s dt .$$

Using Eq. 5.61 for the surface heat flux  $q_x''(t) = q_x''(0, t)$ , find

$$Q = \int_0^{t_\ell} \frac{k(T_s - T_i)}{(\pi\alpha)^{1/2}} A_s \frac{dt}{t^{1/2}} = \frac{2k(T_s - T_i)}{(\pi\alpha)^{1/2}} A_s t_\ell^{1/2}$$

$$Q = \frac{2 \times 0.15 \text{ W/m} \cdot \text{K} (150 - 25)^\circ\text{C}}{(\pi \times 1.00 \times 10^{-7} \text{ m}^2/\text{s})^{1/2}} \times (0.254 \text{ m})^2 \times (2.81 \times 60 \text{ s})^{1/2} = 56 \text{ kJ}$$

&lt;

**COMMENTS:** (1) Increasing the tile-iron temperature would decrease the time required to soften the adhesive, but the risk of burning the adhesive increases.

(2) From the energy calculation of part (b) we can estimate the size of an electrical heater, if operating continuously during the 2.81 min period, to maintain the tile-iron at a near constant temperature. The power required is

$$P = Q/t_\ell = 56 \text{ kJ}/2.81 \times 60 \text{ s} = 330 \text{ W} .$$

Of course a much larger electrical heater would be required to initially heat the tile-iron up to the operating temperature in a reasonable period of time.

### PROBLEM 5.88

**KNOWN:** Procedure for measuring convection heat transfer coefficient, which involves melting of a surface coating.

**FIND:** Melting point of coating for prescribed conditions.

**SCHEMATIC:**

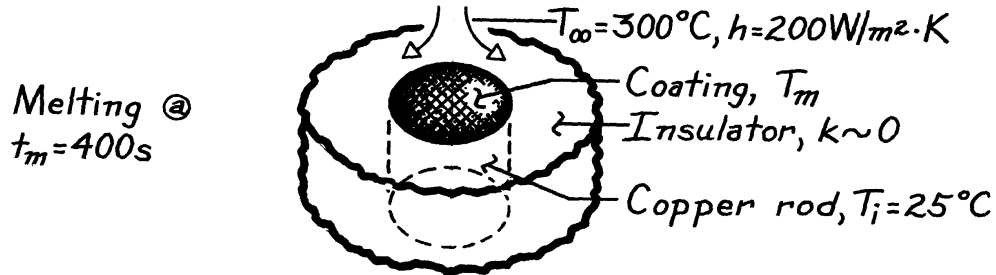

**ASSUMPTIONS:** (1) One-dimensional conduction in solid rod (negligible losses to insulation), (2) Rod approximated as semi-infinite medium, (3) Negligible surface radiation, (4) Constant properties, (5) Negligible thermal resistance of coating.

**PROPERTIES:** Copper rod (Given):  $k = 400\text{ W/m}\cdot\text{K}$ ,  $\alpha = 10^{-4}\text{ m}^2/\text{s}$ .

**ANALYSIS:** Problem corresponds to transient conduction in a semi-infinite solid. Thermal response is given by

$$\frac{T(x,t) - T_i}{T_\infty - T_i} = \text{erfc}\left(\frac{x}{2(\alpha t)^{1/2}}\right) - \left[\exp\left(\frac{hx}{k} + \frac{h^2\alpha t}{k^2}\right)\right] \left[\text{erfc}\left(\frac{x}{2(\alpha t)^{1/2}} + \frac{h(\alpha t)^{1/2}}{k}\right)\right]$$

For  $x = 0$ ,  $\text{erfc}(0) = 1$  and  $T(x,t) = T(0,t) = T_s$ . Hence

$$\frac{T_s - T_i}{T_\infty - T_i} = 1 - \exp\left(\frac{h^2\alpha t}{k^2}\right) \text{erfc}\left(\frac{h(\alpha t)^{1/2}}{k}\right)$$

with

$$\frac{h(\alpha t_m)^{1/2}}{k} = \frac{200\text{ W/m}^2\cdot\text{K} \left(10^{-4}\text{ m}^2/\text{s} \times 400\text{ s}\right)^{1/2}}{400\text{ W/m}\cdot\text{K}} = 0.1$$

$$T_s = T_m = T_i + (T_\infty - T_i) [1 - \exp(0.01) \text{erfc}(0.1)]$$

$$T_s = 25^\circ\text{C} + 275^\circ\text{C} [1 - 1.01 \times 0.888] = 53.5^\circ\text{C} \quad <$$

**COMMENTS:** Use of the procedure to evaluate  $h$  from measurement of  $t_m$  necessitates iterative calculations.

### PROBLEM 5.89

**KNOWN:** Irreversible thermal injury (cell damage) occurs in living tissue maintained at  $T \geq 48^\circ\text{C}$  for a duration  $\Delta t \geq 10\text{s}$ .

**FIND:** (a) Extent of damage for 10 seconds of contact with machinery in the temperature range 50 to  $100^\circ\text{C}$ , (b) Temperature histories at selected locations in tissue ( $x = 0.5, 1, 5\text{ mm}$ ) for a machinery temperature of  $100^\circ\text{C}$ .

**SCHEMATIC:**

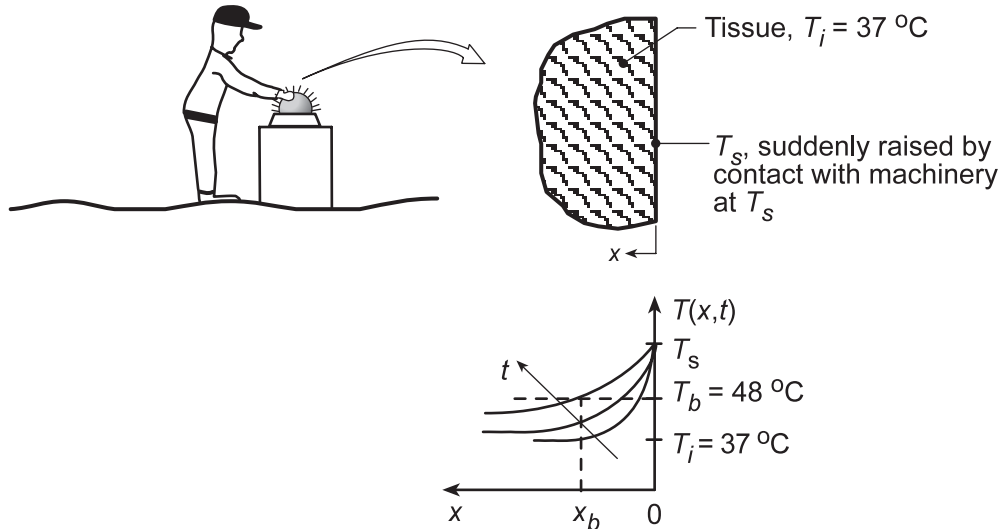

**ASSUMPTIONS:** (1) Portion of worker's body modeled as semi-infinite medium, initially at a uniform temperature,  $37^\circ\text{C}$ , (2) Tissue properties are constant and equivalent to those of water at  $37^\circ\text{C}$ , (3) Negligible contact resistance.

**PROPERTIES:** Table A-6, Water, liquid ( $T = 37^\circ\text{C} = 310\text{ K}$ ):  $\rho = 1/v_f = 993.1\text{ kg/m}^3$ ,  $c = 4178\text{ J/kg}\cdot\text{K}$ ,  $k = 0.628\text{ W/m}\cdot\text{K}$ ,  $\alpha = k/\rho c = 1.513 \times 10^{-7}\text{ m}^2/\text{s}$ .

**ANALYSIS:** (a) For a given surface temperature -- suddenly applied -- the analysis is directed toward finding the skin depth  $x_b$  for which the tissue will be at  $T_b \geq 48^\circ\text{C}$  for more than 10s? From Eq. 5.60,

$$\frac{T(x_b, t) - T_s}{T_i - T_s} = \text{erf} \left[ x_b / 2(\alpha t)^{1/2} \right] = \text{erf} [\eta].$$

For the two values of  $T_s$ , the left-hand side of the equation is

$$T_s = 100^\circ\text{C}: \frac{(48 - 100)^\circ\text{C}}{(37 - 100)^\circ\text{C}} = 0.825 \qquad T_s = 50^\circ\text{C}: \frac{(48 - 50)^\circ\text{C}}{(37 - 50)^\circ\text{C}} = 0.154$$

The burn depth is

$$x_b = [w] 2(\alpha t)^{1/2} = [w] 2 \left( 1.513 \times 10^{-7}\text{ m}^2/\text{s} \times t \right)^{1/2} = 7.779 \times 10^{-4} [w] t^{1/2}.$$

Continued...

### PROBLEM 5.89 (Cont.)

Using Table B.2 to evaluate the error function and letting  $t = 10\text{s}$ , find  $x_b$  as

$$T_s = 100^\circ\text{C}: \quad x_b = 7.779 \times 10^{-4} [0.96](10\text{s})^{1/2} = 2.362 \times 10^{-3} \text{ m} = 2.36 \text{ mm} \quad \angle$$

$$T_s = 50^\circ\text{C}: \quad x_b = 7.779 \times 10^{-4} [0.137](10\text{s})^{1/2} = 3.37 \times 10^{-3} \text{ m} = 0.34 \text{ mm} \quad \angle$$

Recognize that tissue at this depth,  $x_b$ , has not been damaged, but will become so if  $T_s$  is maintained for the next 10s. We conclude that, for  $T_s = 50^\circ\text{C}$ , only superficial damage will occur for a contact period of 20s.

(b) Temperature histories at the prescribed locations are as follows.

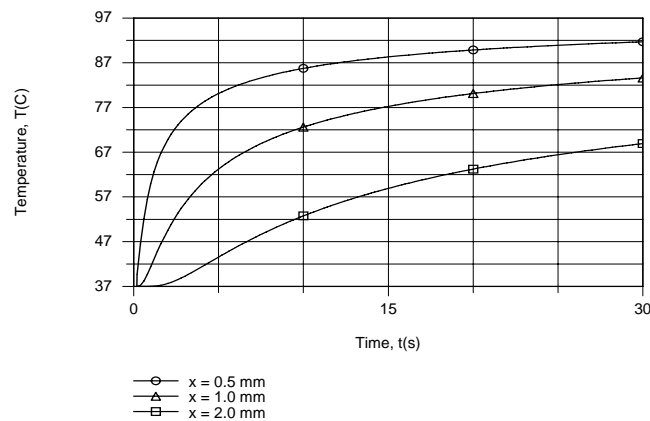

The critical temperature of  $48^\circ\text{C}$  is reached within approximately 1s at  $x = 0.5 \text{ mm}$  and within 7s at  $x = 2 \text{ mm}$ .

**COMMENTS:** Note that the burn depth  $x_b$  increases as  $t^{1/2}$ .

### PROBLEM 5.90

**KNOWN:** Thermocouple location in thick slab. Initial temperature. Thermocouple measurement two minutes after one surface is brought to temperature of boiling water.

**FIND:** Thermal conductivity of slab material.

**SCHEMATIC:**

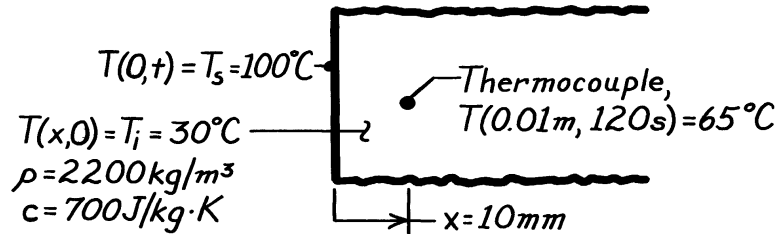

**ASSUMPTIONS:** (1) One-dimensional conduction in  $x$ , (2) Slab is semi-infinite medium, (3) Constant properties.

**PROPERTIES:** Slab material (given):  $\rho = 2200 \text{ kg/m}^3$ ,  $c = 700 \text{ J/kg}\cdot\text{K}$ .

**ANALYSIS:** For the semi-infinite medium from Eq. 5.60,

$$\frac{T(x,t) - T_s}{T_i - T_s} = \text{erf} \left[ \frac{x}{2(\alpha t)^{1/2}} \right]$$

$$\frac{65 - 100}{30 - 100} = \text{erf} \left[ \frac{0.01 \text{ m}}{2(\alpha \times 120 \text{ s})^{1/2}} \right]$$

$$\text{erf} \left[ \frac{0.01 \text{ m}}{2(\alpha \times 120 \text{ s})^{1/2}} \right] = 0.5.$$

From Appendix B, find for erf  $w = 0.5$  that  $w = 0.477$ ; hence,

$$\frac{0.01 \text{ m}}{2(\alpha \times 120 \text{ s})^{1/2}} = 0.477$$

$$(\alpha \times 120)^{1/2} = 0.0105$$

$$\alpha = 9.156 \times 10^{-7} \text{ m}^2/\text{s}.$$

It follows that since  $\alpha = k/\rho c$ ,

$$k = \alpha \rho c$$

$$k = 9.156 \times 10^{-7} \text{ m}^2/\text{s} \times 2200 \text{ kg/m}^3 \times 700 \text{ J/kg}\cdot\text{K}$$

$$k = 1.41 \text{ W/m}\cdot\text{K}.$$

<

## PROBLEM 5.91

**KNOWN:** Very thick plate, initially at a uniform temperature,  $T_i$ , is suddenly exposed to a surface convection cooling process ( $T_\infty, h$ ).

**FIND:** (a) Temperatures at the surface and 45 mm depth after 3 minutes, (b) Effect of thermal diffusivity and conductivity on temperature histories at  $x = 0, 0.045$  m.

**SCHEMATIC:**

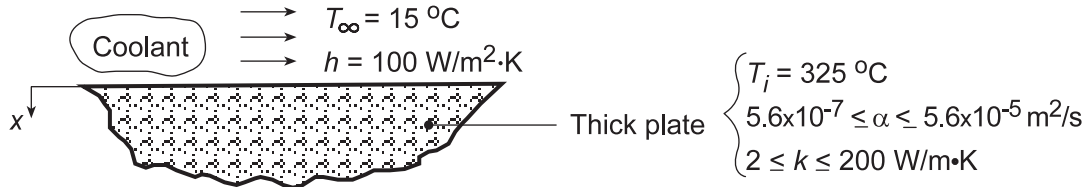

**ASSUMPTIONS:** (1) One-dimensional conduction, (2) Plate approximates semi-infinite medium, (3) Constant properties, (4) Negligible radiation.

**ANALYSIS:** (a) The temperature distribution for a semi-infinite solid with surface convection is given by Eq. 5.63.

$$\frac{T(x, t) - T_i}{T_\infty - T_i} = \text{erfc}\left(\frac{x}{2(\alpha t)^{1/2}}\right) - \left[\exp\left(\frac{hx}{k} + \frac{h^2 \alpha t}{k^2}\right)\right] \left[\text{erfc}\left(\frac{x}{2(\alpha t)^{1/2}} + \frac{h(\alpha t)^{1/2}}{k}\right)\right].$$

At the surface,  $x = 0$ , and for  $t = 3 \text{ min} = 180\text{s}$ ,

$$\begin{aligned} \frac{T(0, 180\text{s}) - 325^\circ\text{C}}{(15 - 325)^\circ\text{C}} &= \text{erfc}(0) - \left[\exp\left(0 + \frac{100^2 \text{ W}^2/\text{m}^4 \text{ K}^2 \times 5.6 \times 10^{-6} \text{ m}^2/\text{s} \times 180\text{s}}{(20 \text{ W/m}\cdot\text{K})^2}\right)\right] \\ &\quad \times \left[\text{erfc}\left(0 + \frac{100 \text{ W/m}^2 \cdot \text{K} (5.6 \times 10^{-6} \text{ m}^2/\text{s} \times 180\text{s})^{1/2}}{20 \text{ W/m}\cdot\text{K}}\right)\right] \\ &= 1 - [\exp(0.02520)] \times [\text{erfc}(0.159)] = 1 - 1.02552 \times (1 - 0.178) \end{aligned}$$

$$T(0, 180\text{s}) = 325^\circ\text{C} - (15 - 325)^\circ\text{C} \cdot (1 - 1.0255 \times 0.822)$$

$$T(0, 180\text{s}) = 325^\circ\text{C} - 49.3^\circ\text{C} = 276^\circ\text{C} . \quad \leftarrow$$

At the depth  $x = 0.045$  m, with  $t = 180\text{s}$ ,

$$\begin{aligned} \frac{T(0.045\text{m}, 180\text{s}) - 325^\circ\text{C}}{(15 - 325)^\circ\text{C}} &= \text{erfc}\left(\frac{0.045 \text{ m}}{2(5.6 \times 10^{-6} \text{ m}^2/\text{s} \times 180\text{s})^{1/2}}\right) - \left[\exp\left(\frac{100 \text{ W/m}^2 \cdot \text{K} \times 0.045 \text{ m}}{20 \text{ W/m}\cdot\text{K}} + 0.02520\right)\right] \\ &\quad \times \left[\text{erfc}\left(\frac{0.045 \text{ m}}{2(5.6 \times 10^{-6} \text{ m}^2/\text{s} \times 180\text{s})^{1/2}} + 0.159\right)\right] \\ &= \text{erfc}(0.7087) + [\exp(0.225 + 0.0252)] \times [\text{erfc}(0.7087 + 0.159)]. \end{aligned}$$

$$T(0.045\text{m}, 180\text{s}) = 325^\circ\text{C} + (15 - 325)^\circ\text{C} [(1 - 0.684) - 1.284(1 - 0.780)] = 315^\circ\text{C} \quad \leftarrow$$

Continued...

## PROBLEM 5.91 (Cont.)

(b) The IHT Transient Conduction Model for a Semi-Infinite Solid was used to generate temperature histories, and for the two locations the effects of varying  $\alpha$  and  $k$  are as follows.

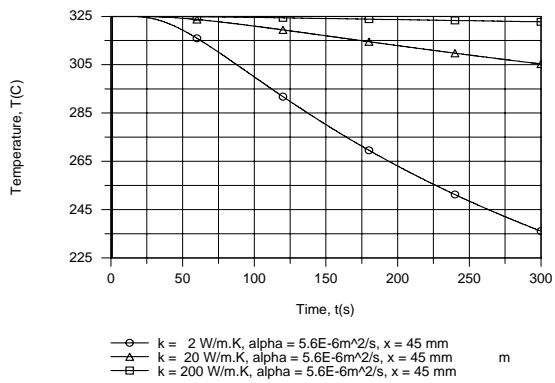
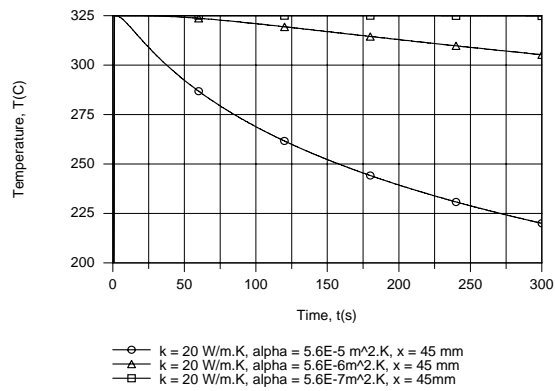
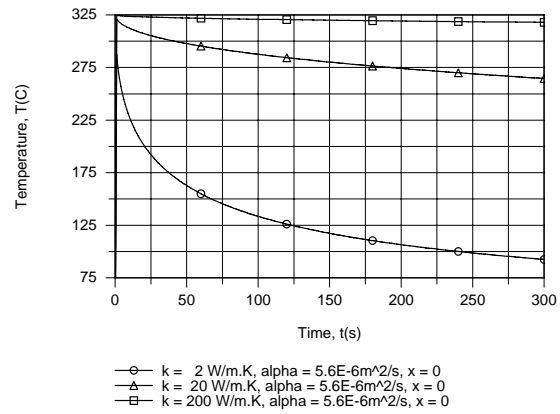
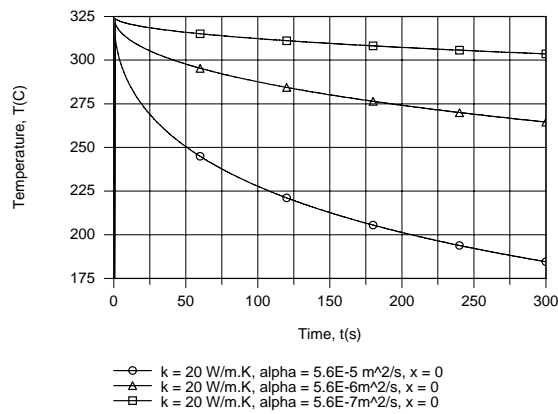

For fixed  $k$ , increasing  $\alpha$  corresponds to a reduction in the thermal capacitance per unit volume ( $\rho c_p$ ) of the material and hence to a more pronounced reduction in temperature at both surface and interior locations. Similarly, for fixed  $\alpha$ , decreasing  $k$  corresponds to a reduction in  $\rho c_p$  and hence to a more pronounced decay in temperature.

**COMMENTS:** In part (a) recognize that Fig. 5.8 could also be used to determine the required temperatures.

## PROBLEM 5.92

**KNOWN:** Thick oak wall, initially at a uniform temperature of 25°C, is suddenly exposed to combustion products at 800°C with a convection coefficient of 20 W/m<sup>2</sup>·K.

**FIND:** (a) Time of exposure required for the surface to reach an ignition temperature of 400°C, (b) Temperature distribution at time t = 325s.

**SCHEMATIC:**

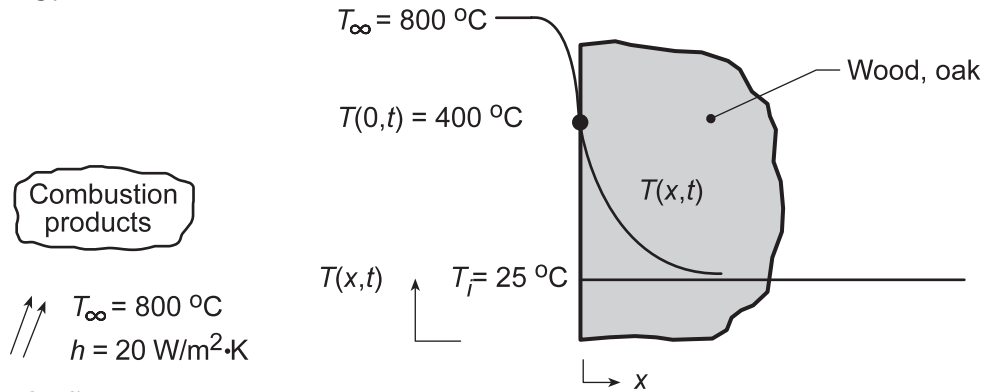

**ASSUMPTIONS:** (1) Oak wall can be treated as semi-infinite solid, (2) One-dimensional conduction, (3) Constant properties, (4) Negligible radiation.

**PROPERTIES:** Table A-3, Oak, cross grain (300 K):  $\rho = 545\text{ kg/m}^3$ ,  $c = 2385\text{ J/kg}\cdot\text{K}$ ,  $k = 0.17\text{ W/m}\cdot\text{K}$ ,  $\alpha = k/\rho c = 0.17\text{ W/m}\cdot\text{K}/545\text{ kg/m}^3 \times 2385\text{ J/kg}\cdot\text{K} = 1.31 \times 10^{-7}\text{ m}^2/\text{s}$ .

**ANALYSIS:** (a) This situation corresponds to Case 3 of Figure 5.7. The temperature distribution is given by Eq. 5.63 or by Figure 5.8. Using the figure with

$$\frac{T(0,t) - T_i}{T_\infty - T_i} = \frac{400 - 25}{800 - 25} = 0.48 \quad \text{and} \quad \frac{x}{2(\alpha t)^{1/2}} = 0$$

we obtain  $h(\alpha t)^{1/2}/k \approx 0.75$ , in which case  $t \approx (0.75k/h\alpha^{1/2})^2$ . Hence,

$$t \approx \left( 0.75 \times 0.17\text{ W/m}\cdot\text{K} / 20\text{ W/m}^2\cdot\text{K} \left( 1.31 \times 10^{-7}\text{ m}^2/\text{s} \right)^{1/2} \right)^2 = 310\text{ s} \quad <$$

(b) Using the IHT *Transient Conduction Model* for a *Semi-infinite Solid*, the following temperature distribution was generated for t = 325s.

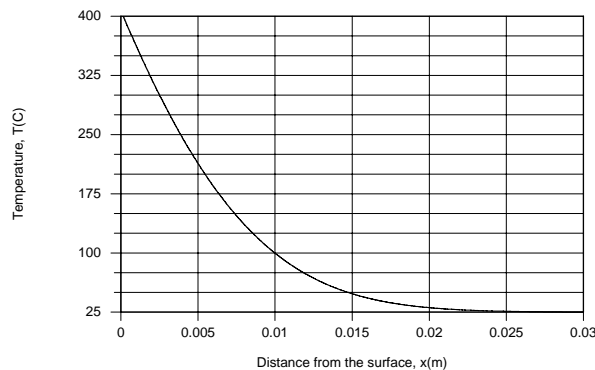

The temperature decay would become more pronounced with decreasing  $\alpha$  (decreasing  $k$ , increasing  $\rho c_p$ ) and in this case the penetration depth of the heating process corresponds to  $x \approx 0.025\text{ m}$  at 325s.

**COMMENTS:** The result of part (a) indicates that, after approximately 5 minutes, the surface of the wall will ignite and combustion will ensue. Once combustion has started, the present model is no longer appropriate.



### PROBLEM 5.93

**KNOWN:** Thickness, initial temperature and thermophysical properties of concrete firewall. Incident radiant flux and duration of radiant heating. Maximum allowable surface temperatures at the end of heating.

**FIND:** If maximum allowable temperatures are exceeded.

**SCHEMATIC:**

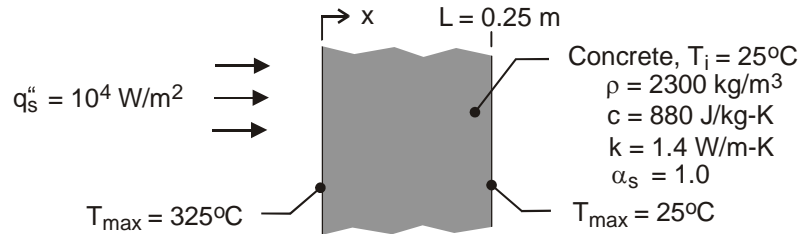

**ASSUMPTIONS:** (1) One-dimensional conduction in wall, (2) Validity of semi-infinite medium approximation, (3) Negligible convection and radiative exchange with the surroundings at the irradiated surface, (4) Negligible heat transfer from the back surface, (5) Constant properties.

**ANALYSIS:** The thermal response of the wall is described by Eq. (5.62)

$$T(x, t) = T_i + \frac{2 q_0'' (\alpha t / \pi)^{1/2}}{k} \exp\left(\frac{-x^2}{4\alpha t}\right) - \frac{q_0'' x}{k} \operatorname{erfc}\left(\frac{x}{2\sqrt{\alpha t}}\right)$$

where,  $\alpha = k / \rho c_p = 6.92 \times 10^{-7} \text{ m}^2 / \text{s}$  and for  $t = 30 \text{ min} = 1800 \text{ s}$ ,  $2q_0'' (\alpha t / \pi)^{1/2} / k = 284.5 \text{ K}$ . Hence, at  $x = 0$ ,

$$T(0, 30 \text{ min}) = 25^\circ\text{C} + 284.5^\circ\text{C} = 309.5^\circ\text{C} < 325^\circ\text{C} \quad <$$

At  $x = 0.25 \text{ m}$ ,  $(-x^2 / 4\alpha t) = -12.54$ ,  $q_0'' x / k = 1,786 \text{ K}$ , and  $x / 2(\alpha t)^{1/2} = 3.54$ . Hence,

$$T(0.25 \text{ m}, 30 \text{ min}) = 25^\circ\text{C} + 284.5^\circ\text{C} (3.58 \times 10^{-6}) - 1786^\circ\text{C} \times (\sim 0) \approx 25^\circ\text{C} \quad <$$

Both requirements are met.

**COMMENTS:** The foregoing analysis is conservative since heat transfer at the irradiated surface due to convection and net radiation exchange with the environment have been neglected. If the emissivity of the surface and the temperature of the surroundings are assumed to be  $\epsilon = 1$  and  $T_{\text{sur}} = 298 \text{ K}$ , radiation exchange at  $T_s = 309.5^\circ\text{C}$  would be  $q_{\text{rad}}'' = \epsilon \sigma (T_s^4 - T_{\text{sur}}^4) = 6,080 \text{ W} / \text{m}^2 \cdot \text{K}$ , which is significant ( $\sim 60\%$  of the prescribed radiation).

### PROBLEM 5.94

**KNOWN:** Initial temperature of copper and glass plates. Initial temperature and properties of finger.

**FIND:** Whether copper or glass feels cooler to touch.

**SCHEMATIC:**

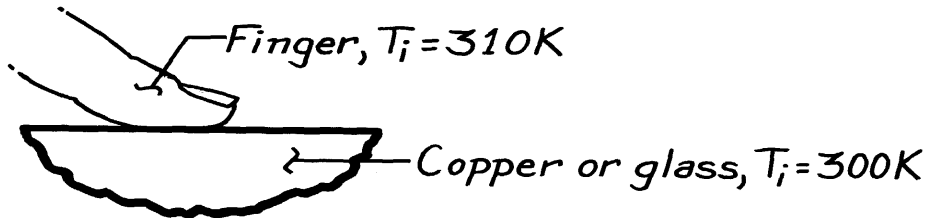

**ASSUMPTIONS:** (1) The finger and the plate behave as semi-infinite solids, (2) Constant properties, (3) Negligible contact resistance.

**PROPERTIES:** Skin (given):  $\rho = 1000 \text{ kg/m}^3$ ,  $c = 4180 \text{ J/kg}\cdot\text{K}$ ,  $k = 0.625 \text{ W/m}\cdot\text{K}$ ; *Table A-1* ( $T = 300\text{K}$ ), Copper:  $\rho = 8933 \text{ kg/m}^3$ ,  $c = 385 \text{ J/kg}\cdot\text{K}$ ,  $k = 401 \text{ W/m}\cdot\text{K}$ ; *Table A-3* ( $T = 300\text{K}$ ), Glass:  $\rho = 2500 \text{ kg/m}^3$ ,  $c = 750 \text{ J/kg}\cdot\text{K}$ ,  $k = 1.4 \text{ W/m}\cdot\text{K}$ .

**ANALYSIS:** Which material feels cooler depends upon the contact temperature  $T_s$  given by Equation 5.66. For the three materials of interest,

$$\begin{aligned} (k\rho c)_{\text{skin}}^{1/2} &= (0.625 \times 1000 \times 4180)^{1/2} = 1,616 \text{ J/m}^2 \cdot \text{K} \cdot \text{s}^{1/2} \\ (k\rho c)_{\text{cu}}^{1/2} &= (401 \times 8933 \times 385)^{1/2} = 37,137 \text{ J/m}^2 \cdot \text{K} \cdot \text{s}^{1/2} \\ (k\rho c)_{\text{glass}}^{1/2} &= (1.4 \times 2500 \times 750)^{1/2} = 1,620 \text{ J/m}^2 \cdot \text{K} \cdot \text{s}^{1/2}. \end{aligned}$$

Since  $(k\rho c)_{\text{cu}}^{1/2} \gg (k\rho c)_{\text{glass}}^{1/2}$ , the copper will feel much cooler to the touch. From Equation 5.66,

$$T_s = \frac{(k\rho c)_A^{1/2} T_{A,i} + (k\rho c)_B^{1/2} T_{B,i}}{(k\rho c)_A^{1/2} + (k\rho c)_B^{1/2}}$$

$$T_{s(\text{cu})} = \frac{1,616(310) + 37,137(300)}{1,616 + 37,137} = 300.4 \text{ K} \quad <$$

$$T_{s(\text{glass})} = \frac{1,616(310) + 1,620(300)}{1,616 + 1,620} = 305.0 \text{ K}. \quad <$$

**COMMENTS:** The extent to which a material's temperature is affected by a change in its thermal environment is inversely proportional to  $(k\rho c)^{1/2}$ . Large  $k$  implies an ability to *spread* the effect by conduction; large  $\rho c$  implies a large capacity for thermal energy *storage*.

### PROBLEM 5.95

**KNOWN:** Initial temperatures, properties, and thickness of two plates, each insulated on one surface.

**FIND:** Temperature on insulated surface of one plate at a prescribed time after they are pressed together.

**SCHEMATIC:**

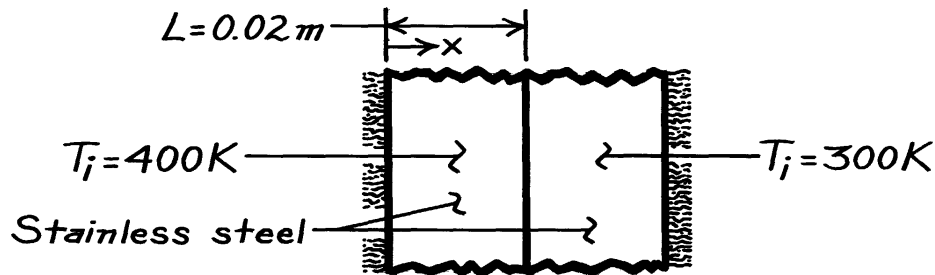

**ASSUMPTIONS:** (1) One-dimensional conduction, (2) Constant properties, (3) Negligible contact resistance.

**PROPERTIES:** Stainless steel (given):  $\rho = 8000 \text{ kg/m}^3$ ,  $c = 500 \text{ J/kg}\cdot\text{K}$ ,  $k = 15 \text{ W/m}\cdot\text{K}$ .

**ANALYSIS:** At the instant that contact is made, the plates behave as semi-infinite slabs and, since the  $(\rho kc)$  product is the same for the two plates, Equation 5.66 yields a surface temperature of

$$T_s = 350 \text{ K}.$$

The interface will remain at this temperature, even after thermal effects penetrate to the insulated surfaces. The transient response of the hot wall may therefore be calculated from Equations 5.43 and 5.44. At the insulated surface ( $x^* = 0$ ), Equation 5.43 yields

$$\frac{T_0 - T_s}{T_i - T_s} = C_1 \exp\left(-\zeta_1^2 Fo\right)$$

where, in principle,  $h \rightarrow \infty$  and  $T_\infty \rightarrow T_s$ . From Equation 5.42c,  $Bi \rightarrow \infty$  yields  $\zeta_1 = 1.5707$ , and from Equation 5.42b

$$C_1 = \frac{4 \sin \zeta_1}{2 \zeta_1 + \sin(2 \zeta_1)} = 1.273$$

Also,

$$Fo = \frac{\alpha t}{L^2} = \frac{3.75 \times 10^{-6} \text{ m}^2/\text{s} (60 \text{ s})}{(0.02 \text{ m})^2} = 0.563.$$

Hence,

$$\frac{T_0 - 350}{400 - 350} = 1.273 \exp\left(-1.5707^2 \times 0.563\right) = 0.318$$

$$T_0 = 365.9 \text{ K}.$$

<

**COMMENTS:** Since  $Fo > 0.2$ , the one-term approximation is appropriate.

## PROBLEM 5.96

**KNOWN:** Thickness and properties of liquid coating deposited on a metal substrate. Initial temperature and properties of substrate.

**FIND:** (a) Expression for time required to completely solidify the liquid, (b) Time required to solidify an alumina coating.

**SCHEMATIC:**

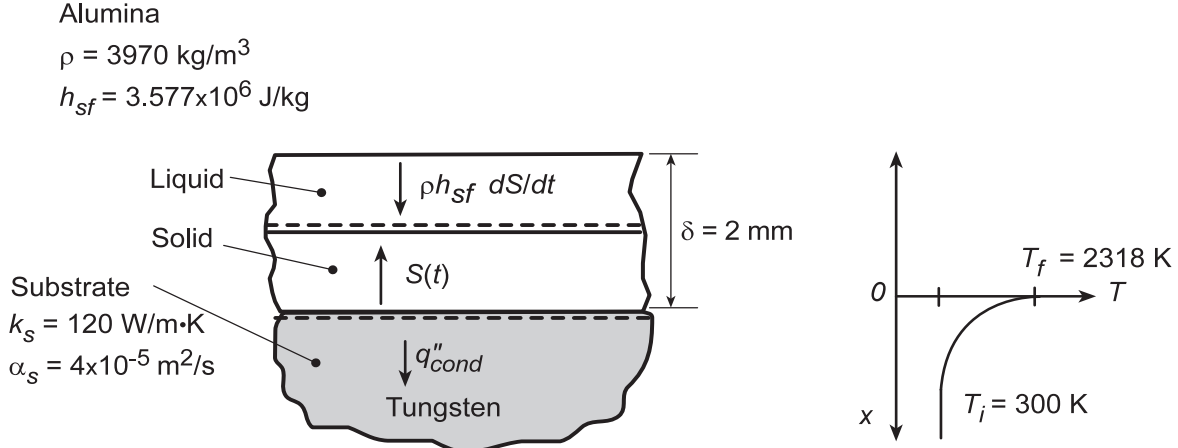

**ASSUMPTIONS:** (1) Substrate may be approximated as a semi-infinite medium in which there is one-dimensional conduction, (2) Solid and liquid alumina layers remain at fusion temperature throughout solidification (negligible resistance to heat transfer by conduction through solid), (3) Negligible contact resistance at the coating/substrate interface, (4) Negligible solidification contraction, (5) Constant properties.

**ANALYSIS:** (a) Performing an energy balance on the solid layer, whose thickness  $S$  increases with  $t$ , the latent heat released at the solid/liquid interface must be balanced by the rate of heat conduction into the solid. Hence, per unit surface area,

$$\rho h_{sf} \frac{dS}{dt} = q''_{cond} \quad \text{where, from Eq. 5.61, } q''_{cond} = k(T_f - T_i) / (\pi \alpha t)^{1/2}. \quad \text{It follows that}$$

$$\rho h_{sf} \frac{dS}{dt} = \frac{k_s (T_f - T_i)}{(\pi \alpha_s t)^{1/2}}$$

$$\int_0^\delta dS = \frac{k_s (T_f - T_i)}{\rho h_{sf} (\pi \alpha_s)^{1/2}} \int_0^t \frac{dt}{t^{1/2}}$$

$$\delta = \frac{2k_s}{(\pi \alpha_s)^{1/2}} \left( \frac{T_f - T_i}{\rho h_{sf}} \right) t^{1/2}$$

$$t = \frac{\pi \alpha_s}{4k_s^2} \left( \frac{\delta \rho h_{sf}}{T_f - T_i} \right)^2 \quad <$$

(b) For the prescribed conditions,

$$t = \frac{\pi (4 \times 10^{-5} \text{ m}^2/\text{s})}{4(120 \text{ W/m}\cdot\text{K})^2} \left( \frac{0.002 \text{ m} \times 3970 \text{ kg/m}^3 \times 3.577 \times 10^6 \text{ J/kg}}{2018 \text{ K}} \right)^2 = 0.43 \quad <$$

**COMMENTS:** If solidification occurs over a short time resulting in a change of the solid's microstructure (relative to slow solidification), it is termed *rapid solidification*. See Problem 5.42.

## PROBLEM 5.97

**KNOWN:** Properties of mold wall and a solidifying metal.

**FIND:** (a) Temperature distribution in mold wall at selected times, (b) Expression for variation of solid layer thickness.

**SCHEMATIC:**

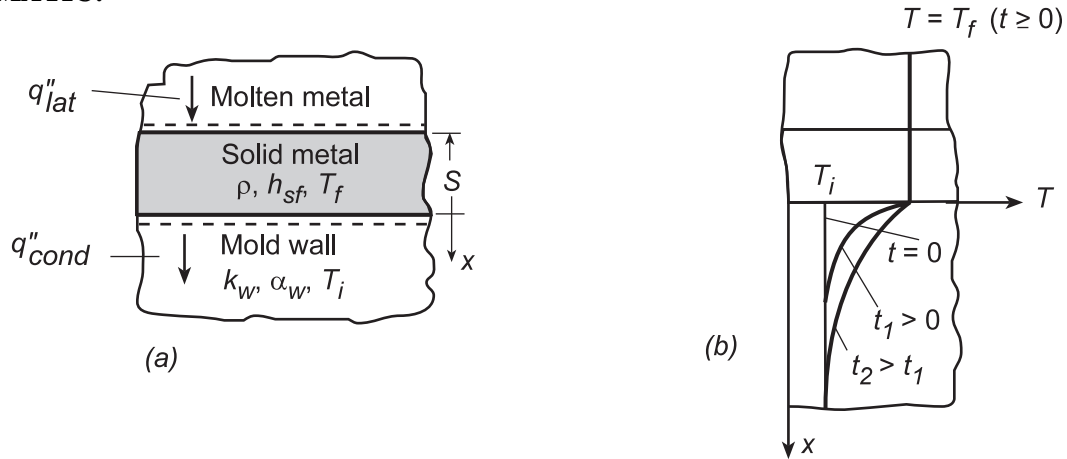

**ASSUMPTIONS:** (1) Mold wall may be approximated as a semi-infinite medium in which there is one-dimensional conduction, (2) Solid and liquid metal layers remain at fusion temperature throughout solidification (negligible resistance to heat transfer by conduction through solid), (3) Negligible contact resistance at mold/metal interface, (4) Constant properties.

**ANALYSIS:** (a) As shown in schematic (b), the temperature remains nearly uniform in the metal (at  $T_f$ ) throughout the process, while both the temperature and temperature penetration increase with time in the mold wall.

(b) Performing an energy balance for a control surface about the solid layer, the latent energy released due to solidification at the solid/liquid interface is balanced by heat conduction into the solid,  $q''_{lat} = q''_{cond}$ , where  $q''_{lat} = \rho h_{sf} dS/dt$  and  $q''_{cond}$  is given by Eq. 5.61. Hence,

$$\rho h_{sf} \frac{dS}{dt} = \frac{k_w (T_f - T_i)}{(\pi \alpha_w t)^{1/2}}$$

$$\int_0^S dS = \frac{k_w (T_f - T_i)}{\rho h_{sf} (\pi \alpha_w)^{1/2}} \int_0^t \frac{dt}{t^{1/2}}$$

$$S = \frac{2k_w (T_f - T_i)}{\rho h_{sf} (\pi \alpha_w)^{1/2}} t^{1/2}$$

**COMMENTS:** The analysis of part (b) would only apply until the temperature field penetrates to the exterior surface of the mold wall, at which point, it may no longer be approximated as a semi-infinite medium.

### PROBLEM 5.98

**KNOWN:** Diameter and initial temperature of two Inconel rods. Amplitude and frequency of motion of upper rod. Coefficient of friction.

**FIND:** Compressive force required to bring rod to melting point in 3 seconds.

**SCHEMATIC:**

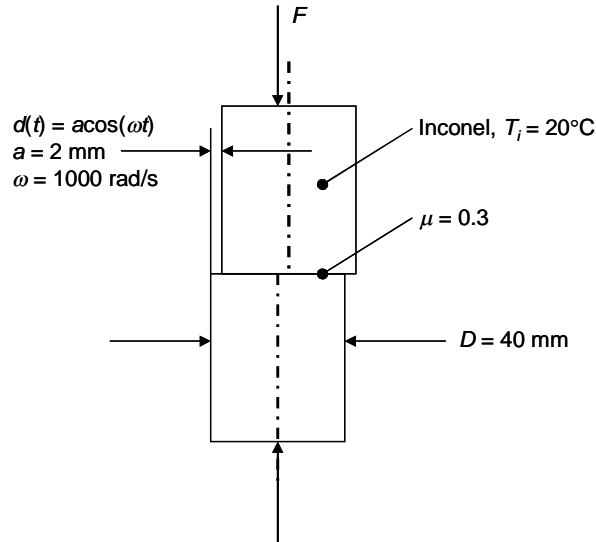

**ASSUMPTIONS:** (1) Negligible heat loss from surfaces of rods, (2) Rods are effectively semi-infinite, (3) Frictional heat generation can be treated as constant in time, (4) Constant properties.

**PROPERTIES:** Table A.1, Inconel X-750:  $T_m = 1665 \text{ K}$ ,  $\bar{T} = (T_i + T_m)/2 = (293 + 1665)/2 = 979 \text{ K}$ ,  $k = 23.6 \text{ W/m}\cdot\text{K}$ ,  $c_p = 618 \text{ J/kg}\cdot\text{K}$ ,  $\rho = 8510 \text{ kg/m}^3$ ,  $\alpha = k/\rho c_p = 4.49 \times 10^{-6} \text{ m}^2/\text{s}$ .

**ANALYSIS:** We begin by expressing the frictional heat flux in terms of the unknown compressive force,  $F_n$ .

$$q'' = -\frac{\vec{F}_t \cdot \vec{V}}{A} = \frac{|\mu F_n V|}{A} = \frac{|\mu F_n|}{A} \frac{dd}{dt} = \frac{|\mu F_n|}{A} a\omega |\sin \omega t|$$

In the above equation, use has been made of the fact that the frictional force always opposes the direction of motion, therefore  $\vec{F}_t \cdot \vec{V} = -|F_t V|$ . The average value of the heat flux is found by integrating over one period of  $|\sin \omega t|$ , namely  $\pi/\omega$ :

$$\bar{q}_s'' = \frac{\omega}{\pi} \int_0^{\pi/\omega} \frac{\mu F_n a \omega}{A} |\sin \omega t| dt = -\frac{1}{\pi} \frac{\mu F_n a \omega}{A} \cos \omega t \Big|_0^{\pi/\omega} = \frac{2\mu F_n a \omega}{\pi A} \quad (1)$$

Continued...

### PROBLEM 5.98 (Cont.)

Note that  $A = \pi D^2/2$ , because heat conducts in both directions. We can find the surface temperature from Eq. 5.62 for the temperature distribution in a semi-infinite solid with uniform surface heat flux. Evaluating that equation at  $x = 0$  yields

$$T_s - T_i = \frac{2\bar{q}_s''(\alpha t/\pi)^{1/2}}{k} \quad (2)$$

With  $T_s$  equal to the melting temperature, we can solve for  $\bar{q}_s''$ :

$$\begin{aligned} \bar{q}_s'' &= \frac{k(T_s - T_i)}{2} \left( \frac{\pi}{\alpha t} \right)^{1/2} \\ &= \frac{23.6 \text{ W/m} \cdot \text{K} (1665 \text{ K} - 293 \text{ K})}{2} \left( \frac{\pi}{4.49 \times 10^{-6} \text{ m}^2/\text{s} \times 3 \text{ s}} \right)^{1/2} \\ &= 7.82 \times 10^6 \text{ W/m}^2 \end{aligned}$$

Then we can solve for  $F_n$  from Eq. (1):

$$F_n = \frac{\bar{q}_s'' \pi A}{2\mu\alpha\omega} = \frac{7.82 \times 10^6 \text{ W/m}^2 \times \pi \times \pi \times (0.04 \text{ m})^2 / 2}{2 \times 0.3 \times 0.002 \text{ m} \times 1000 \text{ rad/s}} = 51.4 \text{ kN} \quad <$$

**Comments:** If the displacement were to be large, the heat transfer would no longer be one-dimensional.

### PROBLEM 5.99

**KNOWN:** Thickness and properties of DVD disk. Laser spot size and power.

**FIND:** Time needed to raise the storage material from 300 K to 1000 K.

**SCHEMATIC:**

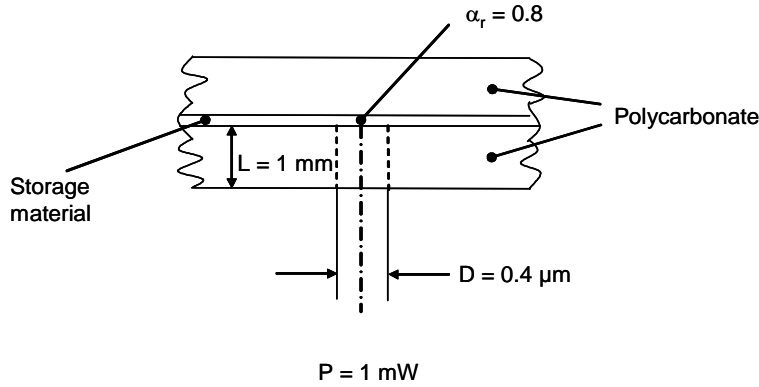

**ASSUMPTIONS:** (1) Negligible contact resistances at the interfaces, (2) Infinite medium, (3) Polycarbonate is transparent to laser irradiation, (4) Polycarbonate is opaque to radiation from the heated spot, (5) Spatially-uniform laser power, (6) Motion of disk does not affect the thermal response, (7) Infinitely thin storage material, (8) Negligible nanoscale heat transfer effects.

**PROPERTIES:** Polycarbonate (given):  $k = 0.21 \text{ W/m}\cdot\text{K}$ ,  $\rho = 1200 \text{ kg/m}^3$ ,  $c_p = 1260 \text{ J/kg}\cdot\text{K}$ .  
Storage material (given):  $\alpha_r = 0.8$

**ANALYSIS:** The heat transferred from the irradiated storage material is

$$q = \alpha_r P \quad (1)$$

From Case 13 of Table 4.1,

$$A_s = \pi D^2/2 \quad (2)$$

From Table 5.2b for  $Fo < 0.2$ ,

$$q^*(Fo) = \frac{q_s'' L_c}{k(T_s - T_i)} = \frac{1}{2} \sqrt{\frac{\pi}{Fo}} + \frac{\pi}{4} \quad (3a)$$

From Table 5.2b for  $Fo \geq 0.2$

$$q^*(Fo) = \frac{q_s'' L_c}{k(T_s - T_i)} = \frac{0.77}{\sqrt{Fo}} + \frac{2\sqrt{2}}{\pi} \quad (3b)$$

where  $L_c = (A_s/4\pi)^{1/2} = D/\sqrt{8}$  ;  $q_s'' = \frac{q}{A_s}$  (4)

and  $Fo = \alpha t/L_c^2 = 8\alpha t/D^2$  (5)

with  $\alpha = k/\rho c = 0.21 \text{ W/m}\cdot\text{K}/(1200 \text{ kg/m}^3 \times 1260 \text{ J/kg}\cdot\text{K}) = 139 \times 10^{-9} \text{ m}^2/\text{s}$ ,

Continued...



**PROBLEM 5.99 (Cont.)**

$$\text{and } \frac{q_s'' L_c}{k(T_s - T_c)} = \frac{2P\alpha_r}{\pi D \sqrt{8k}(T_s - T_i)}$$
$$= \frac{2 \times 1 \times 10^{-3} \text{ W} \times 0.8}{\pi \times 0.4 \times 10^{-6} \times \sqrt{8} \times 0.21 \text{ W/m} \cdot \text{K} \times (1000 - 300) \text{ K}} = 3.0623$$

Equations (3a) and (3b) yield

$$\text{For } Fo < 0.2, Fo = 0.151$$

$$\text{For } Fo \geq 0.2, Fo = 0.127$$

Therefore,  $Fo = 0.151$

<

From Equation (5),

$$t = \frac{FoD^2}{8\alpha} = \frac{0.151 \times (0.4 \times 10^{-6} \text{ m})^2}{8 \times 139 \times 10^{-9} \text{ m}^2/\text{s}} = 21.8 \times 10^{-9} \text{ s} = 21.8 \text{ ns}$$

<

**COMMENTS:** The actual heating rate will be slightly longer due to the finite thickness of the storage medium.

### PROBLEM 5.100

**KNOWN:** Closely-spaced buried tubing, annual temperature variation.

**FIND:** Depth associated with the soil behaving as an infinite medium.

**SCHEMATIC:**

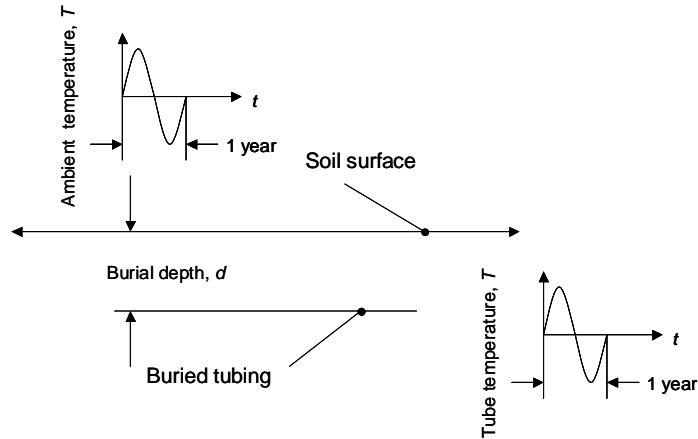

**ASSUMPTIONS:** (1) Periodic conditions, (2) Constant properties, (3) One-dimensional heat transfer (closely-spaced tubing), (4) Diurnal variation in ambient temperature is small relative to its annual variation.

**PROPERTIES:** Table A.3: Soil (300 K):  $\rho = 2050 \text{ kg/m}^3$ ,  $k = 0.52 \text{ W/m}\cdot\text{K}$ ,  $c_p = 1840 \text{ J/kg}\cdot\text{K}$ .

**ANALYSIS:** Since soil heating and cooling is associated with annual changes in both the ambient and buried tubing temperatures, the burial depth,  $d$ , must be larger than twice the penetration depth associated with periodic heating of the soil. Or,

$$d = 2\delta_p = 2 \times 4\sqrt{\alpha/\omega} = 8\sqrt{k/(\rho c_p \omega)}$$

The heating frequency is  $\omega = 2\pi/t_p = 2\pi/(1 \text{ yr} \times 365 \text{ days/yr} \times 24 \text{ h/day} \times 60 \text{ min/h} \times 60 \text{ s/min}) = 200 \times 10^{-9} \text{ s}^{-1}$ . Therefore, the required burial depth is

$$d = 8\sqrt{0.52 \text{ W/m}^2 \cdot \text{K} / (2050 \text{ kg/m}^3 \times 1840 \text{ J/kg} \cdot \text{K} \times 200 \times 10^{-9} \text{ s}^{-1})} = 6.6 \text{ m} \quad <$$

**COMMENTS:** The installation cost increases as the burial depth increases. A tradeoff exists between the installation cost and the attainment of constant soil temperature conditions.

### PROBLEM 5.101

**KNOWN:** Mass and initial temperatures of frozen ground beef. Rate of microwave power absorbed in packaging material.

**FIND:** Time for beef adjacent to packaging to reach 0°C.

**SCHEMATIC:**

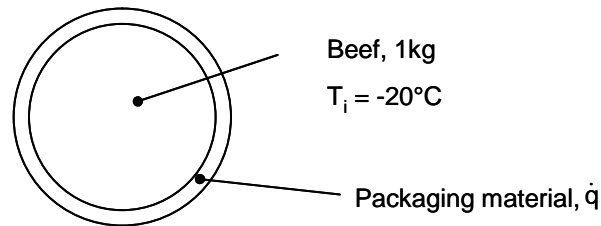

**ASSUMPTIONS:** (1) Beef has properties of ice, (2) Radiation and convection to environment are neglected, (3) Constant properties, (4) Packaging material has negligible heat capacity.

**PROPERTIES:** Table A.3, Ice ( $\approx 273$  K):  $\rho = 920$  kg/m<sup>3</sup>,  $c = 2040$  J/kg·K,  $k = 1.88$  W/m·K.

**ANALYSIS:** Neglecting radiation and convection losses, all the power absorbed in the packaging material conducts into the beef. The surface heat flux is

$$q_s'' = \frac{\dot{q}}{A_s} = \frac{0.5P}{4\pi R^2}$$

The radius of the sphere can be found from knowledge of the mass and density:

$$m = \rho V = \rho \frac{4}{3} \pi r_0^3$$

$$R = \left( \frac{3}{4\pi} \frac{m}{\rho} \right)^{1/3} = \left( \frac{3}{4\pi} \frac{1 \text{ kg}}{920 \text{ kg/m}^3} \right)^{1/3} = 0.0638 \text{ m}$$

Thus

$$q_s'' = \frac{0.5(1000 \text{ W})}{4\pi(0.0638 \text{ m})^2} = 9780 \text{ W/m}^2$$

For a constant surface heat flux, the relationship in Table 5.2b, Interior Cases, sphere, can be used. We begin by calculating  $q^*$  for  $T_s = 0^\circ\text{C}$ .

$$q^* = \frac{q_s'' r_0}{k(T_s - T_i)} = \frac{9780 \text{ W/m}^2 \times 0.0638 \text{ m}}{1.88 \text{ W/m} \cdot \text{K}(0^\circ\text{C} - (-20^\circ\text{C}))} = 16.6$$

We proceed to solve for  $Fo$ . Assuming that  $Fo < 0.2$ , we have

$$q^* \cong \frac{1}{2} \sqrt{\frac{\pi}{Fo}} - \frac{\pi}{4}$$

Continued...

**PROBLEM 5.101 (Cont.)**

$$Fo = \pi \left[ 2(q^* + \frac{\pi}{4}) \right]^{-2} = 0.0026$$

Since this is less than 0.2, our assumption was correct. Finally we can solve for the time:

$$\begin{aligned} t &= Fo r_0^2 / \alpha = Fo r_0^2 \rho c / k \\ &= (0.0026 \times (0.0638 \text{ m})^2 \times 920 \text{ kg/m}^3 \times 2040 \text{ J/kg} \cdot \text{K}) / (1.88 \text{ W/m} \cdot \text{K}) \\ &= 10.6 \text{ s} \end{aligned}$$

<

**COMMENTS:** At the minimum surface temperature of  $-20^\circ\text{C}$ , with  $T_\infty = 30^\circ\text{C}$  and  $h = 15 \text{ W/m}^2 \cdot \text{K}$  from Problem 5.33, the convection heat flux is  $750 \text{ W/m}^2$ , which is less than 8% of the microwave heat flux. The radiation heat flux would likely be less, depending on the temperature of the oven walls.

## PROBLEM 5.102

**KNOWN:** Cylinder with constant surface temperature.

**FIND:** Expression for  $Q/Q_o$  as a function of  $Fo = \alpha t/r_o^2$ .

**SCHEMATIC:**

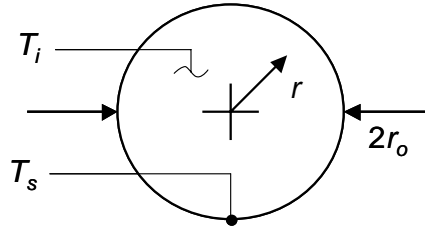

**ASSUMPTIONS:** (1) One-dimensional conduction, (2) Constant properties, (3) Validity of the approximate solution of Table 5.2a.

**ANALYSIS:** From Table 5.2a for  $Fo < 0.2$ ,

$$q_s^* = \frac{\dot{q}_s'' r_o}{k(T_s - T_i)} = \frac{1}{\sqrt{\pi Fo}} - 0.50 - 0.65 Fo \quad ; \quad Fo = \frac{\alpha t}{r_o^2}$$

Substituting the expression for  $Fo$  into the first equation yields

$$q_s'' = \frac{k(T_s - T_i)}{r_o} \left[ \frac{r_o}{\sqrt{\pi \alpha}} t^{-1/2} - 0.50 - 0.65 \frac{\alpha t}{r_o^2} \right]$$

We desire an expression for  $Q/Q_o$ . Hence,

$$\frac{Q}{Q_o} = \frac{Q'}{Q_o'} = \frac{2\pi r_o \int_{t=0}^t q_s'' dt}{\pi r_o^2 \rho c (T_s - T_i)} = \frac{2\alpha}{r_o^2} \int_{t=0}^t \left( \frac{r_o}{\sqrt{\pi \alpha}} t^{-1/2} - 0.50 - 0.65 \frac{\alpha t}{r_o^2} \right) dt$$

or

$$\frac{Q}{Q_o} = \frac{2\alpha t}{r_o^2} \left[ 2 \frac{r_o}{\sqrt{\pi \alpha t}} - 0.50 - 0.325 \frac{\alpha t}{r_o^2} \right]$$

$$= \frac{4}{\sqrt{\pi}} \sqrt{Fo} - Fo - 0.65 Fo^2 \quad \leftarrow$$

**COMMENTS:** (1) A plot of  $Q/Q_o$  versus  $Fo$  is shown below. (2) The exact solution for  $Q/Q_o$  involves many terms that would need to be evaluated in the infinite series expression. (2) See Lavine and Bergman, "Small and Large Time Solutions for Surface Temperature, Surface Heat Flux, and Energy Input in Transient, One-Dimensional Conduction in Simple Geometries," *ASME Journal of Heat Transfer*, Vol 130, pp. 101302-1 to 101302-8, 2008 for details.

Continued...

**PROBLEM 5.102 (Cont.)**

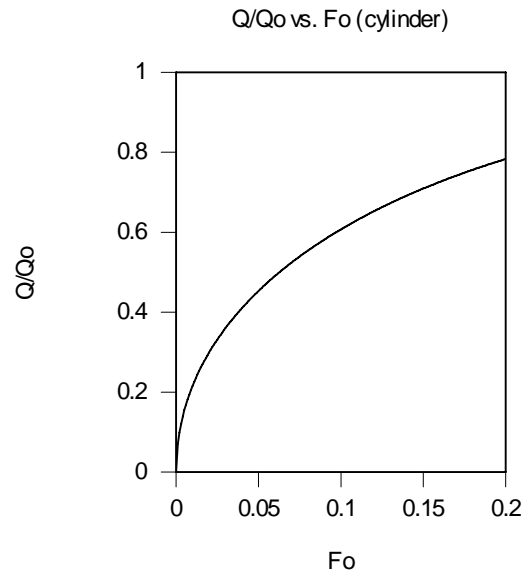

### PROBLEM 5.103

**KNOWN:** Thickness and initial temperature of composite skin. Properties of material when intact and when delaminated. Imposed surface heat flux.

**FIND:** Surface temperature of (a) intact material and (b) delaminated material, after 10 and 100 seconds.

**SCHEMATIC:**

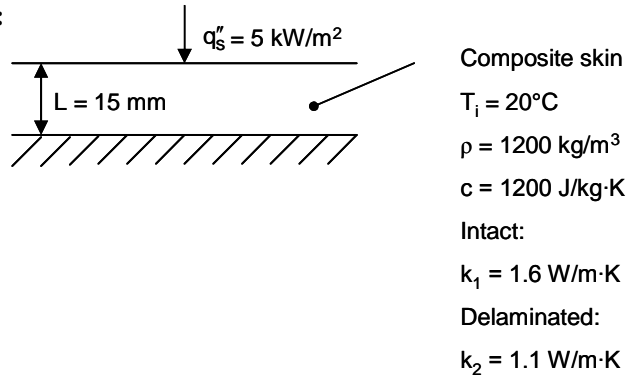

**ASSUMPTIONS:** (1) One-dimensional heat conduction, (2) Bottom surface adiabatic, (3) Constant and uniform properties, (4) Negligible convection and radiation losses.

**ANALYSIS:**

(a) The situation is equivalent to a plane wall of thickness  $2L$  with heat flux at both surfaces. We use Table 5.2b, Interior Cases, Plane Wall of thickness  $2L$ . We first calculate  $Fo$  for the intact case at  $t = 10 \text{ s}$ .

$$\begin{aligned} Fo &= \frac{\alpha t}{L^2} = \frac{k_1 t}{\rho c L^2} \\ &= \frac{1.6 \text{ W/m}\cdot\text{K} \times 10 \text{ s}}{1200 \text{ kg/m}^3 \times 1200 \text{ J/kg}\cdot\text{K} \times (0.015 \text{ m})^2} \\ &= 0.0494 \end{aligned}$$

Since  $Fo < 0.2$ ,

$$q^* \cong \frac{1}{2} \sqrt{\frac{\pi}{Fo}} = \frac{1}{2} \sqrt{\frac{\pi}{0.0494}} = 3.99$$

Thus

$$\begin{aligned} T_{s,1}(10 \text{ s}) &= T_i + q_s'' L / k_1 q^* \\ &= 20^\circ\text{C} + 5000 \text{ W/m}^2 \times 0.015 \text{ m} / (1.6 \text{ W/m}\cdot\text{K} \times 3.99) \\ &= 31.8^\circ\text{C} \end{aligned}$$

<

At  $t = 100 \text{ s}$ ,  $Fo = 0.494 > 0.2$ , thus

$$q^* \cong \left[ Fo + \frac{1}{3} \right]^{-1} = 1.21$$

Continued...

### PROBLEM 5.103 (Cont.)

and

$$\begin{aligned} T_{s,1}(100 \text{ s}) &= T_i + q_s'' L / k_1 q^* \\ &= 20^\circ\text{C} + 5000 \text{ W/m}^2 \times 0.015 \text{ m} / (1.6 \text{ W/m} \cdot \text{K} \times 1.21) \\ &= 58.8^\circ\text{C} \end{aligned} \quad <$$

(b) Repeating the calculations for  $k_2 = 1.1 \text{ W/m} \cdot \text{K}$ , we find

$$\begin{aligned} T_{s,2}(10 \text{ s}) &= 34.2^\circ\text{C} \\ T_{s,2}(100 \text{ s}) &= 65.9^\circ\text{C} \end{aligned} \quad \begin{array}{l} < \\ < \end{array}$$

**COMMENTS:** (1) For  $t = 10 \text{ s}$ , the Fourier number is less than 0.2, and the skin behaves as if it were semi-infinite. However for  $t = 100 \text{ s}$ , the heat has penetrated sufficiently far so that the presence of the insulated bottom surface affects the temperature distribution. The surface temperature is higher than it would be for a semi-infinite solid.

(2) The surface temperatures are sufficiently different for the intact and delaminated cases so that detection is possible. The difference increases with increasing heating time, but if the heating time is too long the elevated temperature will damage the material.

(3) Convection and radiation losses may not be negligible.



## PROBLEM 5.104

**KNOWN:** Plane wall, infinite cylinder and sphere each subjected to a constant surface heat flux.

**FIND:** The ratio of (i) the actual surface temperature minus the initial temperature,  $(T_{s,act} - T_i)$ , to (ii) the value of this temperature difference associated with lumped capacitance behavior,  $(T_{s,lc} - T_i)$ , for each of the three geometries. Criteria associated with  $(T_{s,act} - T_i)/(T_{s,lc} - T_i) \leq 1.1$ .

**SCHEMATIC:**

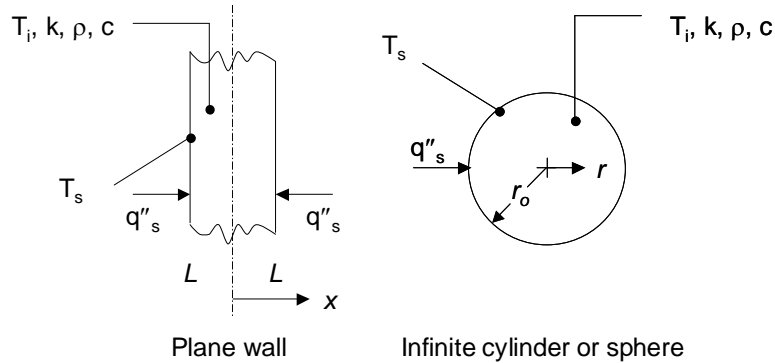

**ASSUMPTIONS:** (1) One-dimensional conduction, (2) Constant properties, (3)  $Fo \geq 0.2$ .

**ANALYSIS:** From Table 5.2b, the approximate solutions for all three geometries may be expressed as

$$\frac{q''_s L_c}{k(T_{s,act} - T_i)} = \left[ a \frac{kt}{\rho c L_c^2} + b \right]^{-1} \quad (1)$$

where  $L_c = L$  for the plane wall, and  $L_c = r_o$  for the infinite cylinder and the sphere. The constants  $a$  and  $b$  have the following values.

Geometry	$L_c$	$a$	$b$
Plane wall	$L$	1	1/3
Infinite cylinder	$r_o$	2	1/4
Sphere	$r_o$	3	1/5

For the lumped-capacitance analysis with constant heat flux, we note that in general,  $q''_s A_s t = \rho c V (T_{s,lc} - T_i)$ . Substituting expressions for the surface area and volume of each of the three geometries results in the general expression,

$$(T_{s,lc} - T_i) = a q''_s t / \rho c L_c \quad (2)$$

where the constant  $a$  is the same as in the table above. Solving Eq. (1) for  $(T_{s,act} - T_i)$  and dividing the resulting expression by Eq. (2) results in

Continued...

**PROBLEM C5.104 (Cont.)**

$$\frac{(T_{s,act} - T_i)}{(T_{s,lc} - T_i)} = \frac{\left[ \frac{q_s'' L_c}{k} \left( a \frac{k}{\rho c L_c^2} t + b \right) \right] \rho c L_c}{a q_s'' t} = \frac{1}{aFo} [aFo + b] = 1 + \frac{b}{aFo} \quad (3)$$

Therefore, for the plane wall,

$$\frac{(T_{s,act} - T_i)}{(T_{s,lc} - T_i)} = 1 + \frac{b}{aFo} = 1 + \frac{1}{3Fo} <$$

for the infinite cylinder,

$$\frac{(T_{s,act} - T_i)}{(T_{s,lc} - T_i)} = 1 + \frac{b}{aFo} = 1 + \frac{1}{8Fo} <$$

for the sphere,

$$\frac{(T_{s,act} - T_i)}{(T_{s,lc} - T_i)} = 1 + \frac{b}{aFo} = 1 + \frac{1}{15Fo} <$$

The preceding equations may be solved for the Fourier number associated with  $(T_{s,act} - T_i)/(T_{s,lc} - T_i) = 1.1$ , yielding critical Fourier numbers,  $Fo_c = 3.33, 1.25$  and  $0.667$  for the plane wall, infinite cylinder, and sphere, respectively. Lumped capacitance behavior is exhibited at dimensionless times greater than  $Fo_c$ .

**COMMENTS:** (1) The calculated values of the Fourier number are each greater than 0.2. Hence, use of the approximate solutions for  $Fo \geq 0.2$  is justified. (2) The dimensionless time at which lumped capacitance behavior is reached varies with the geometry.

### PROBLEM 5.105

**KNOWN:** Energy generation rate within a buried spherical container of known size.

**FIND:** Time needed for the surface of the sphere to come within 10 degrees Celsius of the steady-state temperature.

**SCHEMATIC:**

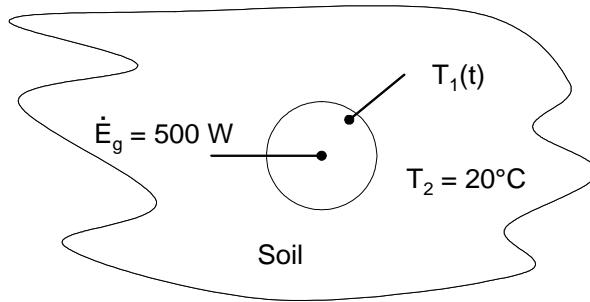

**ASSUMPTIONS:** (1) Infinite medium, (2) Constant properties, (3) Negligible contact resistance between the sphere and the soil.

**PROPERTIES:** Table A.3, soil (300 K):  $k = 0.52 \text{ W/m}\cdot\text{K}$ ,  $\rho = 2050 \text{ kg/m}^3$ ,  $c_p = 1840 \text{ J/kg}\cdot\text{K}$ .

**ANALYSIS:** The steady-state temperature difference may be obtained from case 12 of Table 4.1 with  $L_c = (A_s/4\pi)^{1/2} = (\pi D^2/4\pi)^{1/2} = D/2$

$$q = kA_s(T_{1,ss} - T_2) = 0.52 \text{ W/m}\cdot\text{K} \times \pi \times (2\text{m})^2 \times (T_{1,ss} - T_2) = 500 \text{ W}$$

from which we find

$$T_{1,ss} - T_2 = 76.52^\circ\text{C}$$

Therefore, at the time of interest,  $T_1 - T_2 = 76.52^\circ\text{C} - 10^\circ\text{C} = 66.52^\circ\text{C}$

From Table 5.2b, sphere, exterior case,

$$q^*(\text{Fo}) = \frac{q(D/2)}{\pi D^2 k (T_1 - T_2)} = \frac{1}{\left[1 - \exp(\text{Fo}) \operatorname{erfc}(\text{Fo}^{1/2})\right]}$$

$$\text{or } \frac{1}{\left[1 - \exp(\text{Fo}) \operatorname{erfc}(\text{Fo}^{1/2})\right]} = \frac{500 \text{ W}}{2\pi \times 2 \text{ m} \times 0.52 \text{ W/m}\cdot\text{K} \times 66.52\text{K}} = 1.15$$

Solving for Fo yields  $\text{Fo} = 17.97$ .

Knowing  $\alpha = k/\rho c_p = 0.52 \text{ W/m}\cdot\text{K} / (2050 \text{ kg/m}^3 \times 1840 \text{ J/kg}\cdot\text{K}) = 1.379 \times 10^{-7} \text{ m}^2/\text{s}$

$$t = \frac{\text{Fo} \times (D/2)^2}{\alpha} = \frac{\text{Fo} D^2}{4\alpha} = \frac{17.97 \times (2 \text{ m})^2}{4 \times 1.379 \times 10^{-7} \text{ m}^2/\text{s}}$$

$$t = 1.303 \times 10^8 \text{ s} \times \frac{1 \text{ day}}{24 \text{ h}} \times \frac{1 \text{ h}}{3600 \text{ s}} \times \frac{1 \text{ year}}{365 \text{ days}} = 4.13 \text{ years.} \quad \blacktriangleleft$$

**COMMENTS:** The time to reach the steady-state is significant. In practice, it is often difficult to ascertain when steady-state is achieved due to the slow thermal response time of many systems.

### PROBLEM 5.106

**KNOWN:** Sphere with constant surface temperature.

**FIND:** Expression for  $Q/Q_o$  as a function of  $Fo = \alpha t/r_o^2$ .

**SCHEMATIC:**

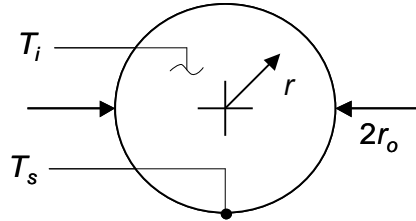

**ASSUMPTIONS:** (1) One-dimensional conduction, (2) Constant properties, (3) Validity of the approximate solution of Table 5.2a.

**ANALYSIS:** From Table 5.2a for  $Fo < 0.2$ ,

$$q_s'' = \frac{q_s'' r_o}{k(T_s - T_i)} = \frac{1}{\sqrt{\pi Fo}} - 1 \quad ; \quad Fo = \frac{\alpha t}{r_o^2}$$

Substituting the expression for  $Fo$  into the first equation yields

$$q_s'' = \frac{k(T_s - T_i)}{r_o} \left[ \frac{r_o}{\sqrt{\pi \alpha}} t^{-1/2} - 1 \right]$$

We desire an expression for  $Q/Q_o$ . Hence,

$$\frac{Q}{Q_o} = \frac{4\pi r_o^2 \int_{t=0}^t q_s'' dt}{(4/3)\pi r_o^3 \rho c (T_s - T_i)} = \frac{3\alpha}{r_o^2} \int_{t=0}^t \left( \frac{r_o}{\sqrt{\pi \alpha}} t^{-1/2} - 1 \right) dt$$

or

$$\frac{Q}{Q_o} = \frac{3\alpha}{r_o^2} \left[ \frac{2r_o}{\sqrt{\pi \alpha}} t^{1/2} - t \right]$$

$$= 3 \left[ \frac{2}{\sqrt{\pi}} \sqrt{Fo} - Fo \right]$$

<

**COMMENTS:** (1) A plot of  $Q/Q_o$  versus  $Fo$  is shown below. (2) The exact solution for  $Q/Q_o$  involves many terms that would need to be evaluated in the infinite series expression.

Continued...

**PROBLEM 5.106 (Cont.)**

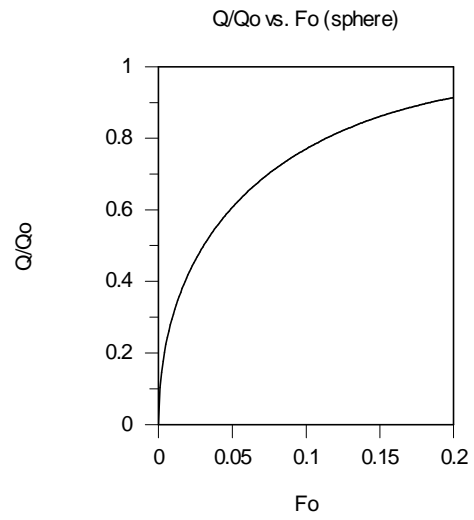

### PROBLEM 5.107

**KNOWN:** Desired minimum temperature response of a  $3\omega$  measurement.

**FIND:** Minimum sample thickness that can be measured.

**ASSUMPTIONS:** (1) Constant properties, (2) Two-dimensional conduction, (3) Semi-infinite medium, (4) Negligible radiation and convection losses from the metal strip and the top surface of the sample.

**PROPERTIES:** (Example 5.10):  $k = 1.11 \text{ W/m}\cdot\text{K}$ ,  $\alpha = 4.37 \times 10^{-7} \text{ m}^2/\text{s}$ .

**ANALYSIS:** Equation 5.74 maybe rearranged to yield

$$\omega = 2 \exp \left[ 2 \left( C_2 - \frac{\Delta T L \pi k}{\Delta q_s} \right) \right]$$
$$\omega = 2 \times \exp \left[ 2 \left( 5.35 - \frac{0.1^\circ\text{C} \times 3.5 \times 10^{-3} \text{ m} \times \pi \times 1.11 \text{ W/m}\cdot\text{K}}{3.5 \times 10^{-3} \text{ W}} \right) \right]$$
$$\omega = 44.2 \times 10^3 \text{ rad/s}$$
$$\alpha = 4.37 \times 10^{-7} \text{ m}^2/\text{s}$$

Therefore

$$\delta_p = \sqrt{\alpha/\omega} = \sqrt{4.37 \times 10^{-7} \text{ m}^2/\text{s} / 44.2 \times 10^3 \text{ rad/s}} = 3.1 \times 10^{-6} \text{ m} = 3.1 \text{ }\mu\text{m}$$

The minimum sample thickness is therefore 3.1  $\mu\text{m}$ . <

**COMMENTS:** (1) To ensure the thickness of the sample is adequate, the actual minimum thickness should be greater than the thermal penetration depth. (2) The sample thickness could be increased further by increasing the amplitude of the heating rate,  $\Delta q_s$ . (3) It is commonly desired to measure very thin samples to discern the effect of the top and bottom boundaries of a *thin film* on the conduction heat transfer rate, as depicted in Figure 2.6. As the film becomes thinner, the experimental uncertainties increase.

### PROBLEM 5.108

**KNOWN:** Stability criterion for the explicit method requires that the coefficient of the  $T_m^p$  term of the one-dimensional, finite-difference equation be zero or positive.

**FIND:** For  $Fo > 1/2$ , the finite-difference equation will predict values of  $T_m^{p+1}$  which violate the Second law of thermodynamics. Consider the prescribed numerical values.

**SCHEMATIC:**

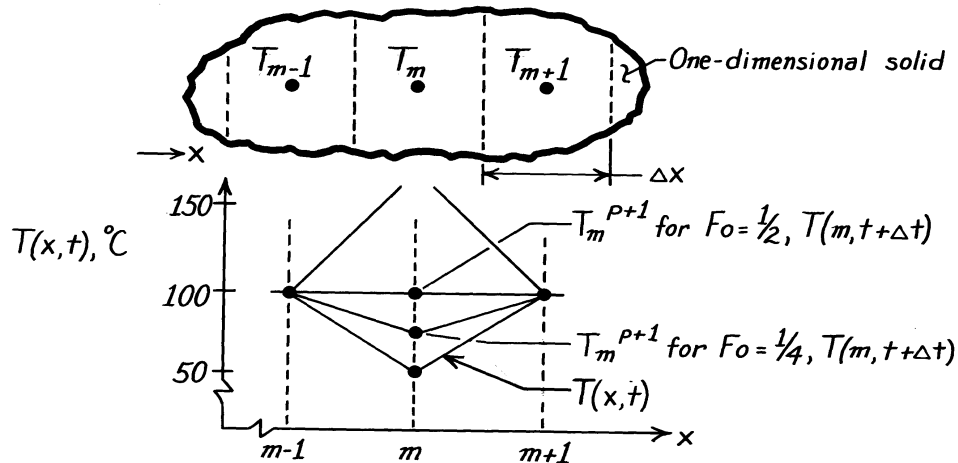

**ASSUMPTIONS:** (1) One-dimensional conduction in  $x$ , (2) Constant properties, (3) No internal heat generation.

**ANALYSIS:** The explicit form of the finite-difference equation, Eq. 5.81, for an interior node is

$$T_m^{p+1} = Fo(T_{m+1}^p + T_{m-1}^p) + (1 - 2Fo)T_m^p.$$

The stability criterion requires that the coefficient of  $T_m^p$  be zero or greater. That is,

$$(1 - 2Fo) \geq 0 \quad \text{or} \quad Fo \leq \frac{1}{2}.$$

For the prescribed temperatures, consider situations for which  $Fo = 1$ ,  $1/2$  and  $1/4$  and calculate  $T_m^{p+1}$ .

$$\begin{aligned} Fo = 1 & \quad T_m^{p+1} = 1(100 + 100)^\circ\text{C} + (1 - 2 \times 1)50^\circ\text{C} = 250^\circ\text{C} \\ Fo = 1/2 & \quad T_m^{p+1} = 1/2(100 + 100)^\circ\text{C} + (1 - 2 \times 1/2)50^\circ\text{C} = 100^\circ\text{C} \\ Fo = 1/4 & \quad T_m^{p+1} = 1/4(100 + 100)^\circ\text{C} + (1 - 2 \times 1/4)50^\circ\text{C} = 75^\circ\text{C}. \end{aligned}$$

Plotting these distributions above, note that when  $Fo = 1$ ,  $T_m^{p+1}$  is greater than  $100^\circ\text{C}$ , while for  $Fo = 1/2$  and  $1/4$ ,  $T_m^{p+1} \leq 100^\circ\text{C}$ . The distribution for  $Fo = 1$  is thermodynamically impossible: heat is flowing into the node during the time period  $\Delta t$ , causing its temperature to rise; yet heat is flowing in the direction of increasing temperature. This is a violation of the Second law. When  $Fo = 1/2$  or  $1/4$ , the node temperature increases during  $\Delta t$ , but the temperature gradients for heat flow are proper. This will be the case when  $Fo \leq 1/2$ , verifying the stability criterion.

### PROBLEM 5.109

**KNOWN:** Thin rod of diameter  $D$ , initially in equilibrium with its surroundings,  $T_{sur}$ , suddenly passes a current  $I$ ; rod is in vacuum enclosure and has prescribed electrical resistivity,  $\rho_e$ , and other thermophysical properties.

**FIND:** Transient, finite-difference equation for node  $m$ .

**SCHEMATIC:**

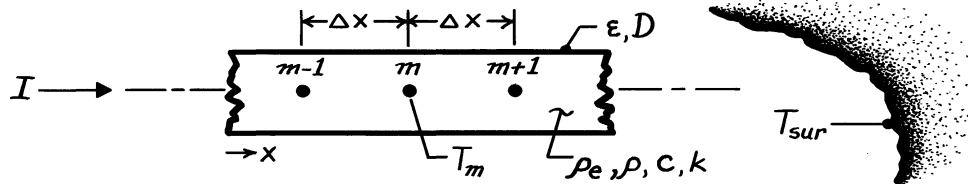

**ASSUMPTIONS:** (1) One-dimensional, transient conduction in rod, (2) Surroundings are much larger than rod, (3) Properties are constant and evaluated at an average temperature, (4) No convection within vacuum enclosure.

**ANALYSIS:** The finite-difference equation is derived from the energy conservation requirement on the control volume,

$A_c \Delta x$ , where  $A_c = \pi D^2 / 4$  and  $P = \pi D$ .

The energy balance has the form

$$\dot{E}_{in} - \dot{E}_{out} + \dot{E}_g = \dot{E}_{st} \quad q_a + q_b - q_{rad} + I^2 R_e = \rho c V \frac{T_m^{p+1} - T_m^p}{\Delta t}$$

where  $\dot{E}_g = I^2 R_e$  and  $R_e = \rho_e \Delta x / A_c$ . Using Fourier's law to express the conduction terms,  $q_a$  and  $q_b$ , and Eq. 1.7 for the radiation exchange term,  $q_{rad}$ , find

$$k A_c \frac{T_{m-1}^p - T_m^p}{\Delta x} + k A_c \frac{T_{m+1}^p - T_m^p}{\Delta x} - \varepsilon P \Delta x \sigma (T_m^{4,p} - T_{sur}^4) + I^2 \frac{\rho_e \Delta x}{A_c} = \rho c A_c \Delta x \frac{T_m^{p+1} - T_m^p}{\Delta t}$$

Divide each term by  $\rho c A_c \Delta x / \Delta t$ , solve for  $T_m^{p+1}$  and regroup to obtain

$$T_m^{p+1} = \frac{k}{\rho c} \cdot \frac{\Delta t}{\Delta x^2} (T_{m-1}^p + T_{m+1}^p) - \left[ 2 \cdot \frac{k}{\rho c} \cdot \frac{\Delta t}{\Delta x^2} - 1 \right] T_m^p - \frac{\varepsilon P \sigma}{A_c} \cdot \frac{\Delta t}{\rho c} (T_m^{4,p} - T_{sur}^4) + \frac{I^2 \rho_e}{A_c^2} \cdot \frac{\Delta t}{\rho c}$$

Recognizing that  $Fo = \alpha \Delta t / \Delta x^2$ , regroup to obtain

$$T_m^{p+1} = Fo (T_{m-1}^p + T_{m+1}^p) + (1 - 2 Fo) T_m^p - \frac{\varepsilon P \sigma \Delta x^2}{k A_c} \cdot Fo (T_m^{4,p} - T_{sur}^4) + \frac{I^2 \rho_e \Delta x^2}{k A_c^2} \cdot Fo$$

The stability criterion is based upon the coefficient of the  $T_m^p$  term written as

$$Fo \leq 1/2$$

<

**COMMENTS:** Note that we have used the forward-difference representation for the time derivative; see Section 5.10.1. This permits convenient treatment of the non-linear radiation exchange term.



### PROBLEM 5.110

**KNOWN:** One-dimensional wall suddenly subjected to uniform volumetric heating and convective surface conditions.

**FIND:** Finite-difference equation for node at the surface,  $x = -L$ .

**SCHEMATIC:**

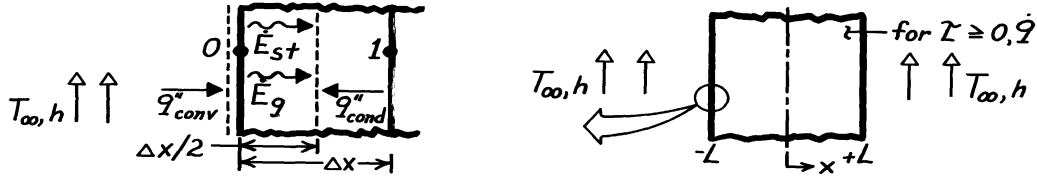

**ASSUMPTIONS:** (1) One-dimensional transient conduction, (2) Constant properties, (3) Uniform  $\dot{q}$ .

**ANALYSIS:** There are two types of finite-difference equations for the *explicit* and *implicit* methods of solution. Using the energy balance approach, both types will be derived.

*Explicit Method.* Perform an energy balance on the surface node shown above,

$$\dot{E}_{\text{in}} - \dot{E}_{\text{out}} + \dot{E}_g = \dot{E}_{\text{st}} \quad q_{\text{conv}} + q_{\text{cond}} + \dot{q}V = \rho cV \frac{T_0^{p+1} - T_0^p}{\Delta t} \quad (1)$$

$$h(1 \cdot 1)(T_\infty - T_0^p) + k(1 \cdot 1) \frac{T_1^p - T_0^p}{\Delta x} + \dot{q} \left[ 1 \cdot 1 \cdot \frac{\Delta x}{2} \right] = \rho c \left[ 1 \cdot 1 \cdot \frac{\Delta x}{2} \right] \frac{T_0^{p+1} - T_0^p}{\Delta t} \quad (2)$$

For the explicit method, the temperatures on the LHS are evaluated at the *previous* time (p). The RHS provides a *forward*-difference approximation to the time derivative. Divide Eq. (2) by  $\rho c \Delta x / 2 \Delta t$  and solve for  $T_0^{p+1}$ .

$$T_0^{p+1} = 2 \frac{h \Delta t}{\rho c \Delta x} (T_\infty - T_0^p) + 2 \frac{k \Delta t}{\rho c \Delta x^2} (T_1^p - T_0^p) + \dot{q} \frac{\Delta t}{\rho c} + T_0^p.$$

Introducing the Fourier and Biot numbers,

$$\text{Fo} \equiv (k/\rho c) \Delta t / \Delta x^2 \quad \text{Bi} \equiv h \Delta x / k$$

$$T_0^{p+1} = 2 \text{Fo} \left[ T_1^p + \text{Bi} \cdot T_\infty + \frac{\dot{q} \Delta x^2}{2k} \right] + (1 - 2 \text{Fo} - 2 \text{Fo} \cdot \text{Bi}) T_0^p. \quad (3)$$

The stability criterion requires that the coefficient of  $T_0^p$  be positive. That is,

$$(1 - 2 \text{Fo} - 2 \text{Fo} \cdot \text{Bi}) \geq 0 \quad \text{or} \quad \text{Fo} \leq 1/2(1 + \text{Bi}). \quad (4) <$$

*Implicit Method.* Begin as above with an energy balance. In Eq. (2), however, the temperatures on the LHS are evaluated at the *new* (p+1) time. The RHS provides a *backward*-difference approximation to the time derivative.

$$h(T_\infty - T_0^{p+1}) + k \frac{T_1^{p+1} - T_0^{p+1}}{\Delta x} + \dot{q} \left[ \frac{\Delta x}{2} \right] = \rho c \left[ \frac{\Delta x}{2} \right] \frac{T_0^{p+1} - T_0^p}{\Delta t} \quad (5)$$

$$(1 + 2 \text{Fo}(\text{Bi} + 1)) T_0^{p+1} - 2 \text{Fo} \cdot T_1^{p+1} = T_0^p + 2 \text{Bi} \cdot \text{Fo} \cdot T_\infty + \text{Fo} \frac{\dot{q} \Delta x^2}{k}. \quad (6) <$$

**COMMENTS:** Compare these results (Eqs. 3, 4 and 6) with the appropriate expression in Table 5.3.

## PROBLEM 5.111

**KNOWN:** Volume of sphere and oil, initial sphere and oil temperatures, convection coefficient, thickness and thermal conductivity of dielectric film coating.

**FIND:** (a) Steady-state sphere temperature of the sphere, (b) explicit expressions for sphere and oil temperatures and stability requirements, (c) Sphere and oil temperatures after one time step for  $\Delta t = 1000, 10,000$  and  $20,000$  s, (d) time needed for the coated sphere to reach  $140^\circ\text{C}$  using an implicit finite difference formulation and solution and graph of thermal response of sphere and oil.

**SCHEMATIC:**

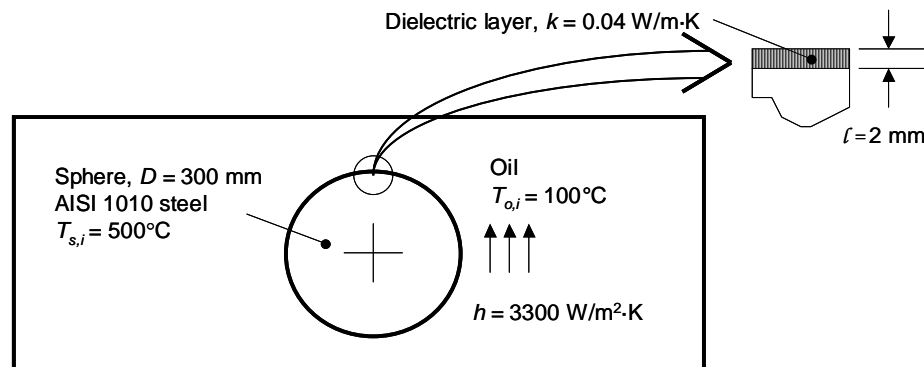

**ASSUMPTIONS:** (1) Dielectric layer has negligible thermal capacitance compared to steel sphere, (2) Constant properties, (3) Negligible contact resistance between dielectric coating and steel, (4) Oil bath is well-stirred, (5) Oil bath is well-insulated.

**PROPERTIES:** Table A-1, AISI 1010 Steel ( $\bar{T} = [500 + 140]^\circ\text{C} / 320^\circ\text{C} \approx 600$  K):  $\rho_s = 7832$  kg/m<sup>3</sup>,  $c_s = 559$  J/kg·K,  $k_s = 48.8$  W/m·K. Table A-5, Engine Oil ( $T = 380$  K):  $\rho_o = 836$  kg/m<sup>3</sup>,  $c_o = 2250$  J/kg·K.

**ANALYSIS:** (a) Let  $U$  be the overall heat transfer coefficient that combines the effects of convection resistance and conduction resistance associated with the dielectric film. That is,  $U = 1/R''$  where  $R'' = l/k_f + 1/h = 0.002\text{m}/0.04$  W/m·K +  $1/3300$  W/m<sup>2</sup>·K =  $0.050 + 0.0003 = 0.0503$  m<sup>2</sup>·K/W. Therefore,  $U = 19.88$  W/m<sup>2</sup>·K. The effective Biot number is

$$Bi_e = \frac{UL_c}{k} = \frac{U(r_o/3)}{k} = \frac{19.88\text{W/m}^2\text{K} \times (0.300\text{m}/6)}{48.8\text{W/m}\cdot\text{K}} = 0.02$$

Since the  $Bi_e < 0.1$ , a lumped capacitance approach is appropriate for the sphere. Similarly, since the oil is well-mixed, a lumped capacitance approach is appropriate for the oil.

The sphere's volume is  $V_s = (4/3)\pi(D/2)^3 = (4/3)\pi(0.300\text{m}/2)^3 = 0.01414\text{m}^3$ . The oil volume is  $V_o = 1$  m<sup>3</sup> -  $0.01414\text{m}^3 = 0.986\text{m}^3$ . Applying energy balances to both the sphere and the oil yields

$$\rho_s c_s V_s (T_{s,i} - T_{ss}) = \rho_o c_o V_o (T_{ss} - T_{o,i}) \quad (1)$$

Continued...

**PROBLEM 5.111 (Cont.)**

where  $T_{ss}$  is the steady-state temperature of both the oil and the sphere. Rearranging Eq. (1) yields

$$T_{ss} = \frac{\rho_s c_s V_s T_{i,s} + \rho_o c_o V_o T_{o,i}}{(\rho_o c_o V_o + \rho_s c_s V_s)}$$

$$= \frac{7832 \text{ kg/m}^3 \times 559 \text{ J/kg} \cdot \text{K} \times 0.01414 \text{ m}^3 \times 500^\circ\text{C} + 836 \text{ kg/m}^3 \times 2250 \text{ J/kg} \cdot \text{K} \times 0.986 \text{ m}^3 \times 100^\circ\text{C}}{(836 \text{ kg/m}^3 + 2250 \text{ J/kg} \cdot \text{K} \times 0.986 \text{ m}^3 + 7832 \text{ kg/m}^3 \times 559 \text{ J/kg} \cdot \text{K} \times 0.01414 \text{ m}^3)}$$

$$= 112.9^\circ\text{C} \quad <$$

(b) Recognizing that the oil temperature varies with time, applying Eqs. 5.2 and 5.77 to the sphere yields

$$T_s^{p+1} = -\frac{UA_s(T_s^p - T_o^p)}{\rho_s c_s V_s} \Delta t + T_s^p \quad (2a)$$

Similarly, applying Eqs. 5.2 and 5.77 to the well-mixed oil leads to the expression

$$T_o^{p+1} = -\frac{UA_s(T_o^p - T_s^p)}{\rho_o c_o V_o} \Delta t + T_o^p \quad (2b)$$

We require the coefficient of  $T^p$  to be positive. Thus,

$$\Delta t < \frac{\rho c V}{UA_s} = 11,000 \text{ s for the steel and } 330,000 \text{ s for the oil.} \quad <$$

(c) Substituting values for the properties, initial temperatures, and volumes into Eqs. (2a) and (2b) for one time step yields the following.

$$T_s^2 = -\frac{19.88 \text{ W/m}^2 \cdot \text{K} \times \pi \times 0.300 \text{ m}^2 \times (500^\circ\text{C} - 100^\circ\text{C})}{7832 \text{ kg/m}^3 \times 559 \text{ J/kg} \cdot \text{K} \times 0.01414 \text{ m}^3} \Delta t + 500^\circ\text{C} = -0.0363^\circ\text{C/s} \times \Delta t + 500^\circ\text{C}$$

$$T_o^2 = -\frac{19.88 \text{ W/m}^2 \cdot \text{K} \times \pi \times 0.300 \text{ m}^2 \times (100^\circ\text{C} - 500^\circ\text{C})}{836 \text{ kg/m}^3 \times 2250 \text{ J/kg} \cdot \text{K} \times 0.986 \text{ m}^3} \Delta t + 100^\circ\text{C} = 1.212 \times 10^{-3}^\circ\text{C/s} \times \Delta t + 100^\circ\text{C}$$

Results for various time steps are:

$\Delta t$ (s)	$T_s^2$ ( $^\circ\text{C}$ )	$T_o^2$ ( $^\circ\text{C}$ )
1000	463.7	101.2
10,000	136.7	112.1
20,000	-226.5	124.2

<

Specification of a time step larger than the stability criterion leads to unrealistic results, as evident in the table above.

Continued...

### PROBLEM 5.111 (Cont.)

(d) Using the *IHT* code listed in the Comments, the following response was found for the sphere and oil temperatures as a function of quench time using a time step of  $\Delta t = 100$ s. The time required for the sphere to reach a temperature of  $140^\circ\text{C}$  is  $28,100 \text{ s} = 7.81 \text{ h}$  <

The time associated with a large oil bath (constant oil temperature) was found in Problem 5.9 using the lumped capacitance method and is  $t = 25,360 \text{ s} = 7.04 \text{ h}$ . <

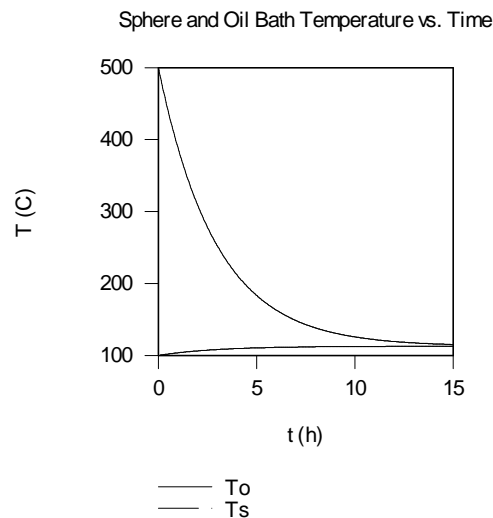

**COMMENTS:** (1) The *IHT* Code is shown below. (2) The bath temperature at 7.81 h is  $112^\circ\text{C}$ , which is nearly equal to the oil's steady-state temperature.

```

rhos = 7832 //kg/m^3
cs = 559 //J/kg-K
Vs = 4*pi*0.15*0.15*0.15/3 //m^3
Tis = 500 //Celsius

rhoo = 836 //kg/m^3
co = 2250 //J/kg-K
Tio = 100 //Celsius
Vo = 1-Vs //m^3

U = 19.88 //W/m^2-K
As = 4*pi*0.15^2 //m^2
thr = t/60/60 //h

Der(Ts,t) = -U*As*(Ts - To)/rhos/cs/Vs
Der(To,t) = -U*As*(To - Ts)/rhoo/co/Vo
    
```

## PROBLEM 5.112

**KNOWN:** Plane wall, initially having a linear, steady-state temperature distribution with boundaries maintained at  $T(0,t) = T_1$  and  $T(L,t) = T_2$ , suddenly experiences a uniform volumetric heat generation due to the electrical current. Boundary conditions  $T_1$  and  $T_2$  remain fixed with time.

**FIND:** (a) On  $T$ - $x$  coordinates, sketch the temperature distributions for the following cases: initial conditions ( $t \leq 0$ ), steady-state conditions ( $t \rightarrow \infty$ ) assuming the maximum temperature exceeds  $T_2$ , and two intermediate times; label important features; (b) For the three-nodal network shown, derive the finite-difference equation using either the implicit or explicit method; (c) With a time increment of  $\Delta t = 5$  s, obtain values of  $T_m$  for the first 45s of elapsed time; determine the corresponding heat fluxes at the boundaries; and (d) Determine the effect of mesh size by repeating the foregoing analysis using grids of 5 and 11 nodal points.

**SCHEMATIC:**

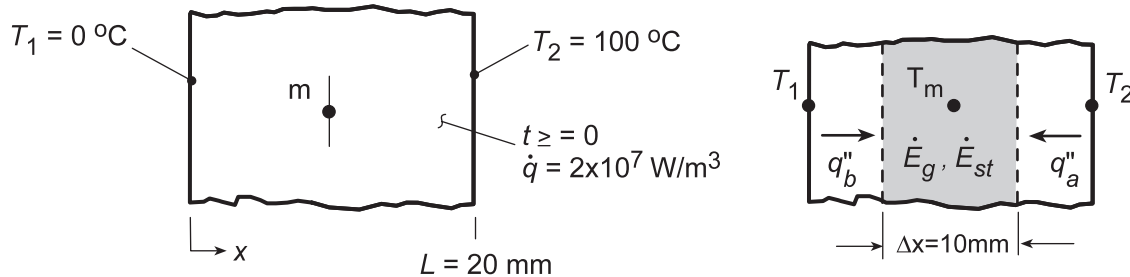

**ASSUMPTIONS:** (1) Two-dimensional, transient conduction, (2) Uniform volumetric heat generation for  $t \geq 0$ , (3) Constant properties.

**PROPERTIES:** Wall (Given):  $\rho = 4000 \text{ kg/m}^3$ ,  $c = 500 \text{ J/kg}\cdot\text{K}$ ,  $k = 10 \text{ W/m}\cdot\text{K}$ .

**ANALYSIS:** (a) The temperature distribution on  $T$ - $x$  coordinates for the requested cases are shown below. Note the following key features: (1) linear initial temperature distribution, (2) non-symmetrical parabolic steady-state temperature distribution, (3) gradient at  $x = L$  is first positive, then zero and becomes negative, and (4) gradient at  $x = 0$  is always positive.

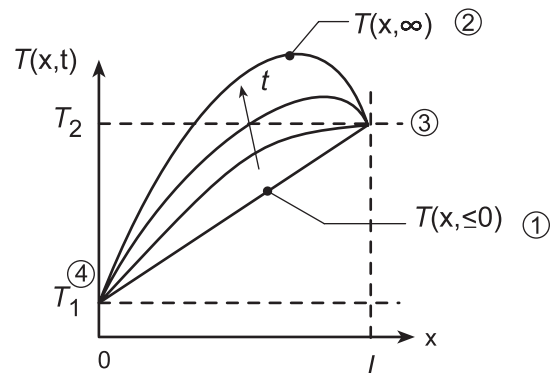

(b) Performing an energy balance on the control volume about node  $m$  above, for unit area, find

$$\dot{E}_{\text{in}} - \dot{E}_{\text{out}} + \dot{E}_g = \dot{E}_{\text{st}}$$

$$k(1) \frac{T_2 - T_m}{\Delta x} + k(1) \frac{T_1 - T_m}{\Delta x} + \dot{q}(1) \Delta x = \rho(1) c \Delta x \frac{T_m^{p+1} - T_m^p}{\Delta t}$$

$$\text{Fo} [T_1 + T_2 - 2T_m] + \frac{\dot{q} \Delta t}{\rho c_p} = T_m^{p+1} - T_m^p$$

For the  $T_m$  term in brackets, use “p” for explicit and “p+1” for implicit form,

$$\text{Explicit: } T_m^{p+1} = \text{Fo} \left( T_1^p + T_2^p \right) + (1 - 2\text{Fo}) T_m^p + \dot{q} \Delta t / \rho c_p \quad (1) <$$

$$\text{Implicit: } T_m^{p+1} = \left[ \text{Fo} \left( T_1^{p+1} + T_2^{p+1} \right) + \dot{q} \Delta t / \rho c_p + T_m^p \right] / (1 + 2\text{Fo}) \quad (2) <$$

Continued...

### PROBLEM 5.112 (Cont.)

(c) With a time increment  $\Delta t = 5\text{ s}$ , the FDEs, Eqs. (1) and (2) become

*Explicit:*  $T_m^{p+1} = 0.5T_m^p + 75$  (3)

*Implicit:*  $T_m^{p+1} = (T_m^p + 75) / 1.5$  (4)

where

$$Fo = \frac{k\Delta t}{\rho c \Delta x^2} = \frac{10 \text{ W/m} \cdot \text{K} \times 5 \text{ s}}{4000 \text{ kg/m}^3 \times 500 \text{ J/kg} \cdot \text{K} (0.010 \text{ m})^2} = 0.25$$

$$\frac{\dot{q}\Delta t}{\rho c} = \frac{2 \times 10^7 \text{ W/m}^3 \times 5 \text{ s}}{4000 \text{ kg/m}^3 \times 500 \text{ J/kg} \cdot \text{K}} = 50 \text{ K}$$

Performing the calculations, the results are tabulated as a function of time,

p	t (s)	T <sub>1</sub> (°C)	T <sub>m</sub> (°C)		T <sub>2</sub> (°C)
			Explicit	Implicit	
0	0	0	50	50	100
1	5	0	100.00	83.33	100
2	10	0	125.00	105.55	100
3	15	0	137.50	120.37	100
4	20	0	143.75	130.25	100
5	25	0	146.88	136.83	100
6	30	0	148.44	141.22	100
7	35	0	149.22	144.15	100
8	40	0	149.61	146.10	100
9	45	0	149.80	147.40	100

<

The heat flux at the boundaries at  $t = 45\text{ s}$  follows from the energy balances on control volumes about the boundary nodes, using the explicit results for  $T_m^p$ ,

*Node 1:*  $\dot{E}_{in} - \dot{E}_{out} + \dot{E}_g = \dot{E}_{st}$

$$q_x''(0, t) + k \frac{T_m^p - T_1}{\Delta x} + \dot{q}(\Delta x/2) = 0$$

$$q_x''(0, t) = -k \left( T_m^p - T_1 \right) / \Delta x - \dot{q}\Delta x/2 \quad (5)$$

$$q_x''(0, 45\text{ s}) = -10 \text{ W/m} \cdot \text{K} (149.8 - 0) \text{ K} / 0.010 \text{ m} - 2 \times 10^7 \text{ W/m}^3 \times 0.010 \text{ m} / 2$$

$$q_x''(0, 45\text{ s}) = -149,800 \text{ W/m}^2 - 100,000 \text{ W/m}^2 = -249,800 \text{ W/m}^2$$

<

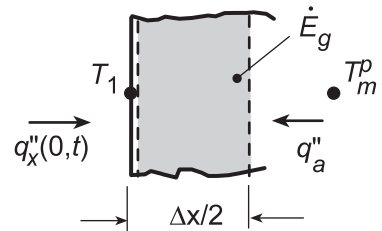

*Node 2:*  $k \frac{T_m^p - T_2}{\Delta x} - q_x''(L, t) + \dot{q}(\Delta x/2) = 0$

$$q_x''(L, t) = k \left( T_m^p - T_2 \right) / \Delta x + \dot{q}\Delta x/2 = 0 \quad (6)$$

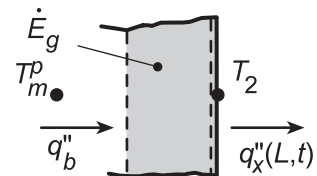

Continued...

### PROBLEM 5.112 (Cont.)

$$q_x''(L, t) = 10 \text{ W/m} \cdot \text{K} (149.80 - 100) \text{ C} / 0.010 \text{ m} + 2 \times 10^7 \text{ W/m}^3 \times 0.010 \text{ m} / 2$$

$$q_x''(L, t) = 49,800 \text{ W/m}^2 + 100,000 \text{ W/m}^2 = +149,800 \text{ W/m}^2 \quad <$$

(d) To determine the effect of mesh size, the above analysis was repeated using grids of 5 and 11 nodal points,  $\Delta x = 5$  and 2 mm, respectively. Using the *IHT Finite-Difference Equation Tool*, the finite-difference equations were obtained and solved for the temperature-time history. Eqs. (5) and (6) were used for the heat flux calculations. The results are tabulated below for  $t = 45\text{s}$ , where  $T_m^P(45\text{s})$  is the center node,

Mesh Size $\Delta x$ (mm)	$T_m^P(45\text{s})$ (°C)	$q_x''(0,45\text{s})$ kW/m <sup>2</sup>	$q_x''(L,45\text{s})$ kW/m <sup>2</sup>
10	149.8	-249.8	+149.8
5	149.3	-249.0	+149.0
2	149.4	-249.1	+149.0

**COMMENTS:** (1) The center temperature and boundary heat fluxes are quite insensitive to mesh size for the condition.

(2) The copy of the IHT workspace for the 5 node grid is shown below.

```
// Mesh size - 5 nodes, deltax = 5 mm
// Nodes a, b(m), and c are interior nodes

// Finite-Difference Equations Tool - nodal
equations
/* Node a: interior node; e and w labeled b and
1. */
rho*cp*der(Ta,t) =
fd_1d_int(Ta,Tb,T1,k,qdot,deltax)
/* Node b: interior node; e and w labeled c and
a. */
rho*cp*der(Tb,t) =
fd_1d_int(Tb,Tc,Ta,k,qdot,deltax)
/* Node c: interior node; e and w labeled 2 and
b. */
rho*cp*der(Tc,t) =
fd_1d_int(Tc,T2,Tb,k,qdot,deltax)

// Assigned Variables:
deltax = 0.005
k = 10
rho = 4000
cp = 500
qdot = 2e7
T1 = 0
T2 = 100

/* Initial Conditions:
Tai = 25
Tbi = 50
Tci = 75 */

/* Data Browser Results - Nodal
temperatures at 45s
Ta      Tb      Tc      t
99.5    149.3    149.5    45 */

// Boundary Heat Fluxes - at t = 45s
q''x0 = - k * (Taa - T1) / deltax - qdot
* deltax / 2
q''xL = k * (Tcc - T2) / deltax + qdot *
deltax / 2
//where Taa = Ta (45s), Tcc =
Tc(45s)
Taa = 99.5
Tcc = 149.5
/* Data Browser results
q''x0      q''xL
-2.49E5    1.49E5 */
```

### PROBLEM 5.113

**KNOWN:** Solid cylinder of plastic material ( $\alpha = 6 \times 10^{-7} \text{ m}^2/\text{s}$ ), initially at uniform temperature of  $T_i = 20^\circ\text{C}$ , insulated at one end ( $T_4$ ), while other end experiences heating causing its temperature  $T_0$  to increase linearly with time at a rate of  $a = 1^\circ\text{C}/\text{s}$ .

**FIND:** (a) Finite-difference equations for the 4 nodes using the explicit method with  $Fo = 1/2$  and (b) Surface temperature  $T_0$  when  $T_4 = 35^\circ\text{C}$ .

**SCHEMATIC:**

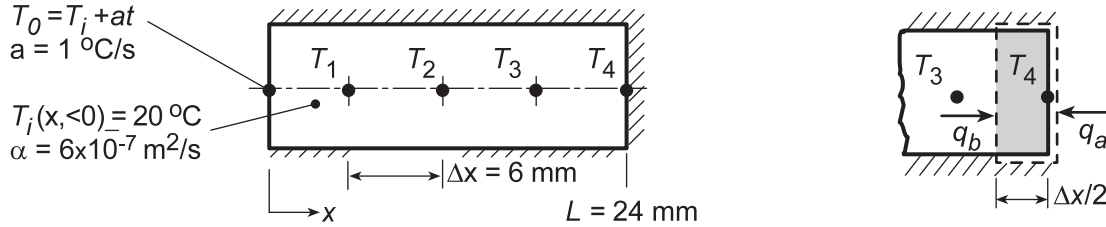

**ASSUMPTIONS:** (1) One-dimensional, transient conduction in cylinder, (2) Constant properties, and (3) Lateral and end surfaces perfectly insulated.

**ANALYSIS:** (a) The finite-difference equations using the *explicit* method for the interior nodes ( $m = 1, 2, 3$ ) follow from Eq. 5.81 with  $Fo = 1/2$ ,

$$T_m^{p+1} = Fo \left( T_{m+1}^p + T_{m-1}^p \right) + (1 - 2Fo) T_m^p = 0.5 \left( T_{m+1}^p + T_{m-1}^p \right) \quad (1)$$

From an energy balance on the control volume node 4 as shown above yields with  $Fo = 1/2$

$$\dot{E}_{in} - \dot{E}_{out} + \dot{E}_g = \dot{E}_{st} \quad q_a + q_b + 0 = \rho c V \left( T_4^{p+1} - T_4^p \right) / \Delta t$$

$$0 + k \left( T_3^p - T_4^p \right) / \Delta x = \rho c \left( \Delta x / 2 \right) \left( T_4^{p+1} - T_4^p \right) / \Delta t$$

$$T_4^{p+1} = 2Fo T_3^p + (1 - 2Fo) T_4^p = T_3^p \quad (2)$$

(b) Performing the calculations, the temperature-time history is tabulated below, where  $T_0 = T_i + a \cdot t$  where  $a = 1^\circ\text{C}/\text{s}$  and  $t = p \cdot \Delta t$  with,

$$Fo = \alpha \Delta t / \Delta x^2 = 0.5 \quad \Delta t = 0.5 (0.006 \text{ m})^2 / 6 \times 10^{-7} \text{ m}^2/\text{s} = 30 \text{ s}$$

p	t (s)	$T_0$ ( $^\circ\text{C}$ )	$T_1$ ( $^\circ\text{C}$ )	$T_2$ ( $^\circ\text{C}$ )	$T_3$ ( $^\circ\text{C}$ )	$T_4$ ( $^\circ\text{C}$ )
0	0	20	20	20	20	20
1	30	50	20	20	20	20
2	60	80	35	20	20	20
3	90	110	50	27.5	20	20
4	120	140	68.75	35	23.75	20
5	150	170	87.5	46.25	27.5	23.75
6	180	200	108.1	57.5	35	27.5
7	210	230	-	-	-	35

When  $T_4(210\text{s}, p = 7) = 35^\circ\text{C}$ , find  $T_0(210\text{s}) = 230^\circ\text{C}$ .





### PROBLEM 5.114

**KNOWN:** Three-dimensional, transient conduction.

**FIND:** Explicit finite difference equation for an interior node, stability criterion.

**SCHEMATIC:**

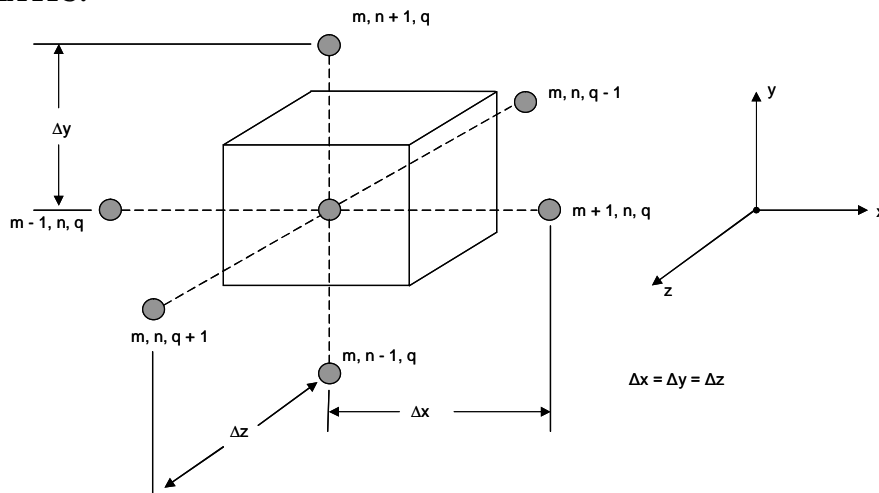

**ASSUMPTIONS:** (1) Constant properties, (2) Equal grid spacing in all three directions, (3) No heat generation.

**ANALYSIS:** We begin with the three-dimensional form of the transient heat equation, Equation 2.19

$$\frac{1}{\alpha} \frac{\partial T}{\partial t} = \frac{\partial^2 T}{\partial x^2} + \frac{\partial^2 T}{\partial y^2} + \frac{\partial^2 T}{\partial z^2}$$

The finite-difference approximation to the time derivative is given by Equation 5.77:

$$\left. \frac{\partial T}{\partial t} \right|_{m,n,q} = \frac{T_{m,n,q}^{p+1} - T_{m,n,q}^p}{\Delta t}$$

The spatial derivatives for the x- and y- directions are given by Equations 4.27 and 4.28, with an extra subscript q. By analogy, the z-direction derivative is approximated as

$$\left. \frac{\partial^2 T}{\partial z^2} \right|_{m,n,q} \approx \frac{T_{m,n,q+1} + T_{m,n,q-1} - 2T_{m,n,q}}{(\Delta z)^2}$$

Evaluating the spatial derivatives at time step p for the explicit method, assuming  $\Delta x = \Delta y = \Delta z$ , yields

Continued...

**PROBLEM 5.114 (Cont.)**

$$\frac{1}{\alpha} \frac{T_{m,n,q}^{p+1} - T_{m,n,q}^p}{\Delta t} = \frac{T_{m+1,n,q}^p + T_{m-1,n,q}^p - 2T_{m,n,q}^p}{(\Delta x)^2} + \frac{T_{m,n+1,q}^p + T_{m,n-1,q}^p - 2T_{m,n,q}^p}{(\Delta x)^2} + \frac{T_{m,n,q+1}^p + T_{m,n,q-1}^p - 2T_{m,n,q}^p}{(\Delta x)^2}$$

Solving for the nodal temperature at time step p+1 results in

$$T_{m,n,q}^{p+1} = Fo(T_{m+1,n,q}^p + T_{m-1,n,q}^p + T_{m,n+1,q}^p + T_{m,n-1,q}^p + T_{m,n,q+1}^p + T_{m,n,q-1}^p) + (1 - 6Fo)T_{m,n,q}^p$$

where  $Fo = \alpha\Delta t/(\Delta x)^2$ . <

The stability criterion is determined by the requirement that the coefficient of  $T_{m,n,q}^p \geq 0$ . Thus <

$$Fo \leq 1/6$$

**COMMENTS:** These results could also have been obtained using the energy balance method applied to a control volume about the interior node.

### PROBLEM 5.115

**KNOWN:** Nodal point located at boundary between two materials A and B.

**FIND:** Two-dimensional explicit, transient finite difference equation.

**SCHEMATIC:**

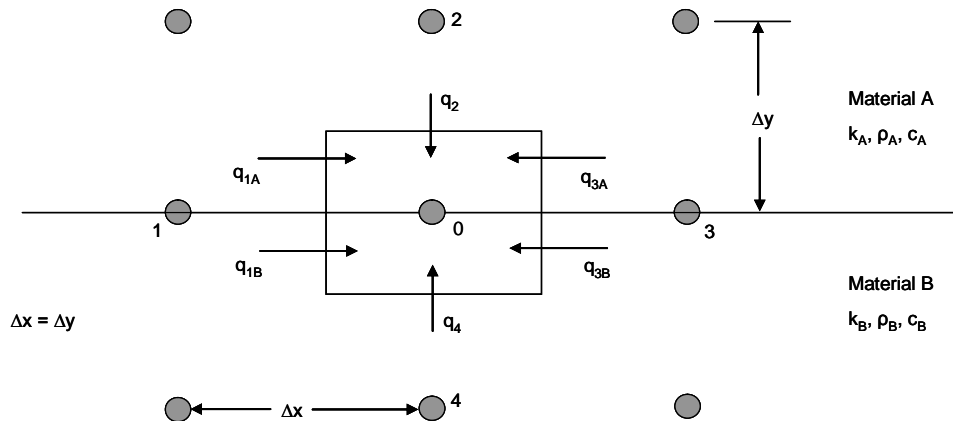

**ASSUMPTIONS:** (1) Two-dimensional conduction, (2) No heat generation, (3) Constant properties (different in each material).

**ANALYSIS:** We perform an energy balance on the control volume around node 0.

$$\dot{E}_{in} = \dot{E}_{st}$$

$$q_{1A} + q_{1B} + q_{3A} + q_{3B} + q_2 + q_4 = \dot{E}_{st,A} + \dot{E}_{st,B}$$

Using  $q_{1A}$  as an example,

$$q_{1A} = k_A \frac{T_1 - T_0}{\Delta x} \frac{\Delta y}{2} w = k_A (T_1 - T_0) w / 2$$

where  $w$  is the depth into the page. The quantities  $q_{1B}$ ,  $q_{3A}$ , and  $q_{3B}$  can be found similarly. Then  $q_2$  is given by

$$q_2 = k_A \frac{T_2 - T_0}{\Delta y} \Delta x w = k_A (T_2 - T_0) w$$

and similarly for  $q_4$ .

The storage term  $\dot{E}_{st,A}$  is given by

$$\dot{E}_{st,A} = \rho_A c_A \Delta x \frac{\Delta y}{2} \frac{T_0^{p+1} - T_0^p}{\Delta t}$$

and similarly for  $\dot{E}_{st,B}$ .

Combining equations yields

Continued....

**PROBLEM 5.115 (Cont.)**

$$k_A \frac{T_1 - T_0}{2} + k_B \frac{T_1 - T_0}{2} + k_A \frac{T_3 - T_0}{2} + k_B \frac{T_3 - T_0}{2} +$$
$$k_A (T_2 - T_0) + k_B (T_4 - T_0) = (\rho_A c_A + \rho_B c_B) \frac{(\Delta x)^2}{2} \frac{T_0^{p+1} - T_0^p}{\Delta t}$$

Rearranging, we find

$$T_0^{p+1} = \frac{(Fo_A + Fo_B)}{2} (T_1^p + T_3^p) + Fo_A T_2^p + Fo_B T_4^p + [1 - 2(Fo_A + Fo_B)] T_0^p \quad <$$

where

$$Fo_A = \frac{2k_A \Delta t}{(\rho_A c_A + \rho_B c_B)(\Delta x)^2}, \quad Fo_B = \frac{2k_B \Delta t}{(\rho_A c_A + \rho_B c_B)(\Delta x)^2}$$

Note, that  $Fo_A \neq \alpha_A \Delta t / (\Delta x)^2$ .

**COMMENTS:** Note that when the material properties are the same for materials A and B, the result agrees with Equation 5.79.

## PROBLEM 5.116

**KNOWN:** A 0.12 m thick wall, with thermal diffusivity  $1.5 \times 10^{-6} \text{ m}^2/\text{s}$ , initially at a uniform temperature of  $85^\circ\text{C}$ , has one face suddenly lowered to  $20^\circ\text{C}$  while the other face is perfectly insulated.

**FIND:** (a) Using the explicit finite-difference method with space and time increments of  $\Delta x = 30 \text{ mm}$  and  $\Delta t = 300 \text{ s}$ , determine the temperature distribution within the wall 45 min after the change in surface temperature; (b) Effect of  $\Delta t$  on temperature histories of the surfaces and midplane.

**SCHEMATIC:**

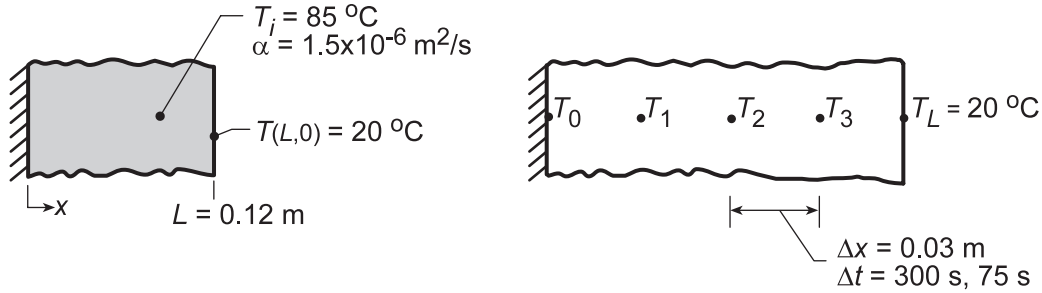

**ASSUMPTIONS:** (1) One-dimensional transient conduction, (2) Constant properties.

**ANALYSIS:** (a) The finite-difference equations for the interior points, nodes 0, 1, 2, and 3, can be determined from Equation 5.81,

$$T_m^{p+1} = \text{Fo} \left( T_{m-1}^p + T_{m+1}^p \right) + (1 - 2\text{Fo}) T_m^p \quad (1)$$

with

$$\text{Fo} = \alpha \Delta t / \Delta x^2 = 1.5 \times 10^{-6} \text{ m}^2/\text{s} \times 300 \text{ s} / (0.03 \text{ m})^2 = 1/2. \quad (2)$$

Note that the stability criterion, Equation 5.82,  $\text{Fo} \leq 1/2$ , is satisfied. Hence, combining Equations (1) and (2),  $T_m^{p+1} = 1/2 \left( T_{m-1}^p + T_{m+1}^p \right)$  for  $m = 0, 1, 2, 3$ . Since the adiabatic plane at  $x = 0$  can be treated as a symmetry plane,  $T_{m-1} = T_{m+1}$  for node 0 ( $m = 0$ ). The finite-difference solution is generated in the table below using  $t = p \cdot \Delta t = 300 p \text{ (s)} = 5 p \text{ (min)}$ .

p	t(min)	$T_0$	$T_1$	$T_2$	$T_3$	$T_L(^{\circ}\text{C})$
0	0	85	85	85	85	20
1		85	85	85	52.5	20
2	10	85	85	68.8	52.5	20
3		85	76.9	68.8	44.4	20
4	20	76.9	76.9	60.7	44.4	20
5		76.9	68.8	60.7	40.4	20
6	30	68.8	68.8	54.6	40.4	20
7		68.8	61.7	54.6	37.3	20
8	40	61.7	61.7	49.5	37.3	20
9	45	61.7	55.6	49.5	34.8	20

<

The temperature distribution can also be determined from the one-term approximation of the exact solution. The insulated surface is equivalent to the midplane of a wall of thickness  $2L$ . Thus,

$$\text{Fo} = \frac{\alpha t}{L^2} = \frac{1.5 \times 10^{-6} \text{ m}^2/\text{s} \times (45 \times 60) \text{ s}}{(0.12 \text{ m})^2} = 0.28 \quad \text{and} \quad \text{Bi} \rightarrow \infty.$$

Continued...

### PROBLEM 5.116 (Cont.)

From Table 5.1,  $\zeta_1 = 1.5707$ ,  $C_1 = 1.2733$ . Then from Equation 5.44,

$$\theta_0^* = C_1 \exp(-\zeta_1^2 Fo) = 1.2733 \exp(-1.5707^2 \times 0.28) = 0.64 \quad \text{or}$$

$$T_0 = T(0, t) = T_\infty + \theta_0^* (T_i - T_\infty) = 20^\circ\text{C} + 0.64(85 - 20)^\circ\text{C} = 61.5^\circ\text{C}.$$

This value shows excellent agreement with  $61.7^\circ\text{C}$  for the finite-difference method.

(b) Using the IHT *Finite-Difference Equation Tool Pad for One-Dimensional Transient Conduction*, temperature histories were computed and results are shown for the insulated surface (T0) and the midplane, as well as for the chilled surface (TL).

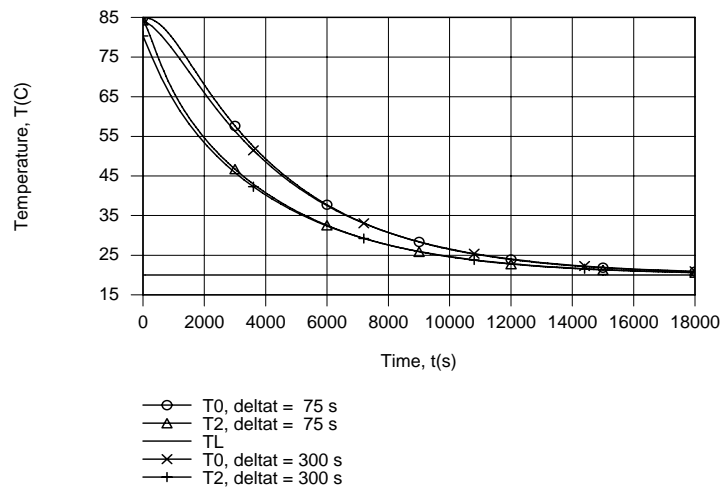

Apart from small differences during early stages of the transient, there is excellent agreement between results obtained for the two time steps. The temperature decay at the insulated surface must, of course, lag that of the midplane.

### PROBLEM 5.117

**KNOWN:** Thickness, initial temperature and thermophysical properties of molded plastic part. Convection conditions at one surface. Other surface insulated.

**FIND:** Surface temperatures after one hour of cooling.

**SCHEMATIC:**

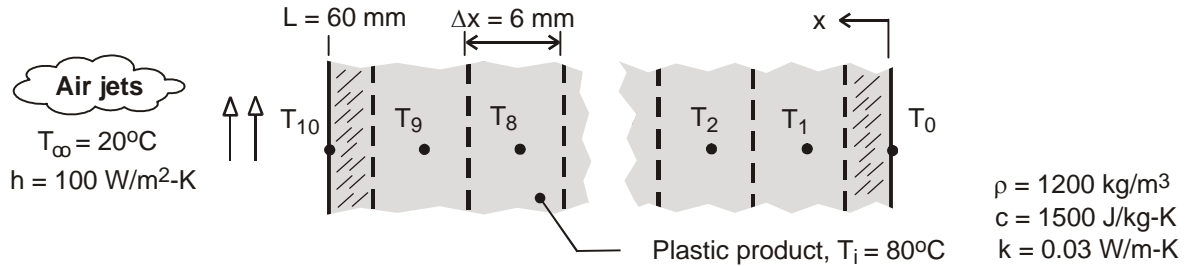

**ASSUMPTIONS:** (1) One-dimensional conduction in product, (2) Negligible radiation, at cooled surface, (3) Negligible heat transfer at insulated surface, (4) Constant properties.

**ANALYSIS:** Adopting the implicit scheme, the finite-difference equation for the cooled surface node is given by Eq. (5.96), from which it follows that

$$(1 + 2Fo + 2FoBi)T_{10}^{p+1} - 2FoT_9^{p+1} = 2FoBiT_\infty + T_{10}^p$$

The general form of the finite-difference equation for any interior node (1 to 9) is given by Eq. (5.97),

$$(1 + 2Fo)T_m^{p+1} - Fo(T_{m-1}^{p+1} + T_{m+1}^{p+1}) = T_m^p$$

The finite-difference equation for the insulated surface node may be obtained by applying the symmetry requirement to Eq. (5.97); that is,  $T_{m+1}^p = T_{m-1}^p$ . Hence,

$$(1 + 2Fo)T_0^{p+1} - 2FoT_1^{p+1} = T_0^p$$

For the prescribed conditions,  $Bi = h\Delta x/k = 100 \text{ W/m}^2 \cdot \text{K} (0.006\text{m})/0.03 \text{ W/m} \cdot \text{K} = 2$ . If the explicit method were used, the most restrictive stability requirement would be given by Eq. (5.87). Hence, for  $Fo(1+Bi) \leq 0.5$ ,  $Fo \leq 0.167$ . With  $Fo = \alpha\Delta t/\Delta x^2$  and  $\alpha = k/\rho c = 1.67 \times 10^{-7} \text{ m}^2/\text{s}$ , the corresponding restriction on the time increment would be  $\Delta t \leq 36\text{s}$ . Although no such restriction applies for the implicit method, a value of  $\Delta t = 30\text{s}$  is chosen, and the set of 11 finite-difference equations is solved using the *Tools* option designated as *Finite-Difference Equations, One-Dimensional, and Transient* from the IHT Toolpad. At  $t = 3600\text{s}$ , the solution yields:

$$T_{10}(3600\text{s}) = 24.1^\circ\text{C} \quad T_0(3600\text{s}) = 71.5^\circ\text{C} \quad <$$

**COMMENTS:** (1) More accurate results may be obtained from the one-term approximation to the exact solution for one-dimensional, transient conduction in a plane wall. With  $Bi = hL/k = 20$ , Table 5.1 yields  $\zeta_1 = 1.496 \text{ rad}$  and  $C_1 = 1.2699$ . With  $Fo = \alpha t/L^2 = 0.167$ , Eq. (5.41) then yields  $T_o = T_\infty + (T_i - T_\infty) C_1 \exp(-\zeta_1^2 Fo) = 72.4^\circ\text{C}$ , and from Eq. (5.43b),  $T_s = T_\infty + (T_i - T_\infty) \cos(\zeta_1) = 24.5^\circ\text{C}$ .

Since the finite-difference results do not change with a reduction in the time step ( $\Delta t < 30\text{s}$ ), the difference between the numerical and analytical results is attributed to the use of a coarse grid. To improve the accuracy of the numerical results, a smaller value of  $\Delta x$  should be used.

Continued ...

### PROBLEM 5.117 (Cont.)

(2) Temperature histories for the front and back surface nodes are as shown.

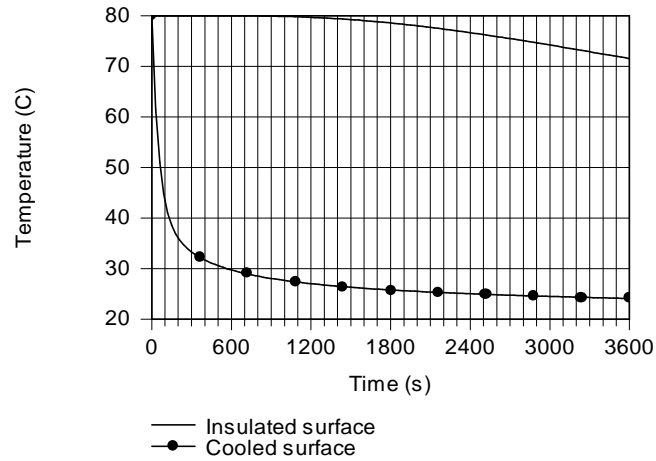

Although the surface temperatures rapidly approaches that of the coolant, there is a significant lag in the thermal response of the back surface. The different responses are attributable to the small value of  $\alpha$  and the large value of  $Bi$ .



## PROBLEM 5.118

**KNOWN:** Thickness and thermal diffusivity of a plane wall. Initial and boundary conditions.

**FIND:** (a) Time required for the left face temperature to reach 50% of its maximum possible temperature reduction and (b) Time required for the left face temperature to recover to a 20% temperature reduction when the right face temperature is returned to its initial value.

**SCHEMATIC:**

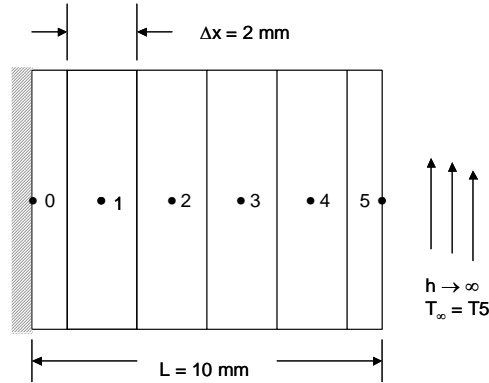

**ASSUMPTIONS:** (1) One-dimensional heat transfer, (2) Constant properties.

**PROPERTIES:** Thermal diffusivity,  $\alpha = 6 \times 10^{-7} \text{ m}^2/\text{s}$  (given).

**ANALYSIS:** Using the *IHT Finite-Difference Equation Tool Pad for One-Dimensional Transient Conduction*, the following temperatures may be computed using the *IHT* code in the Comments section. Note that for this solution, the conditions at the right face have been incorporated by specifying a very large convection coefficient at the right face so that  $T_5 \approx T_\infty$ .

(a) For cooling conditions, the initial temperature is arbitrarily set to unity, and  $T_\infty = T_{s,r} = 0.5$ . If a steady-state solution were achieved, it would correspond to a uniform wall temperature of  $T_{ss} = T_{s,r} = 0.5$ . Hence we seek to determine the time when  $T_0 = (T_i + T_{s,r})/2 = 0.75$ . The following representative results are obtained using a time step of  $\Delta t = 2 \text{ s}$ .

$t(\text{s})$	$T_0$	$T_1$	$T_2$	$T_3$	$T_4$	$T_5$
20	0.952	0.937	0.888	0.798	0.665	0.5
40	0.852	0.835	0.787	0.710	0.611	0.5
60	0.765	0.752	0.714	0.656	0.582	0.5
<u>64</u>	0.750	0.738	0.702	0.647	0.577	0.5

<

(b) For the heating conditions, we set the initial conditions in *IHT* to the temperatures shown at  $t = 64$  in the table above. We set  $T_\infty = 1$  and monitor the transient response of the system. The following representative results are obtained.

$t(\text{s})$	$T_0$	$T_1$	$T_2$	$T_3$	$T_4$	$T_5$
20	0.735	0.741	0.763	0.812	0.893	1.0
40	0.789	0.798	0.826	0.872	0.932	1.0
60	0.840	0.848	0.870	0.906	0.950	1.0
80	0.880	0.886	0.903	0.930	0.963	1.0
<u>94</u>	0.902	0.907	0.921	0.943	0.970	1.0

<

Continued...

## PROBLEM 5.118 (Cont.)

**COMMENTS:** (1) The *IHT* Code for cooling and heating is shown below. (2) Note the thermal response of  $T_0$  after heating ensues at the right face. The value of  $T_0$  continues to decrease for a short time before it begins to increase in value. Does this make sense to you? (3) Part (a) was solved analytically in Problem 5.57 yielding  $t = 63$  s. The numerical and analytical solutions are in agreement to within an uncertainty associated with the time step of  $\Delta t = 2$  s.

```
/* Node 0: surface node (w-orientation); transient conditions; e labeled 1. */
rho * cp * der(T0,t) = fd_1d_sur_w(T0,T1,k,qdot,deltax,Tinf,h1,qfla0)

/* Node 1: interior node; e and w labeled e and 0. */
rho*cp*der(T1,t) = fd_1d_int(T1,T2,T0,k,qdot,deltax)

/* Node 2: interior node; e and w labeled 3 and 1. */
rho*cp*der(T2,t) = fd_1d_int(T2,T3,T1,k,qdot,deltax)

/* Node 3: interior node; e and w labeled 4 and 2. */
rho*cp*der(T3,t) = fd_1d_int(T3,T4,T2,k,qdot,deltax)

/* Node 4: interior node; e and w labeled 4 and 3. */
rho*cp*der(T4,t) = fd_1d_int(T4,T5,T3,k,qdot,deltax)

/* Node 5: surface node (e-orientation); transient conditions; w labeled 4. */
rho * cp * der(T5,t) = fd_1d_sur_e(T5,T4,k,qdot,deltax,Tinf,h2,qfla5)

// Cooling
//Tinf = 0.5           //Initial Conditions are T = 1.0 everywhere.
//Heating             //Initial Conditions are the temperatures at t = 64 s.
Tinf = 1.0

h1 = 0                //Insulated left wall
h2 = 1*10^10          //Right wall at Tinf since h2 is nearly infinite
qfla0 = 0             //Zero applied heat flux at left wall
qfla5 = 0             //Zero applied heat flux at right wall
deltax = 2/1000       //meters
qdot = 0              //W/m^3

// Set k, rho and cp values so that alpha = k/(rho*cp) = 6*10^-7 m2/s

k = 6*10^-7           //W/m-K
rho = 1               //kg
cp = 1                //J/kg-K
```

## PROBLEM 5.119

**KNOWN:** Plane wall, initially at a uniform temperature  $T_o = 25^\circ\text{C}$ , has one surface ( $x = L$ ) suddenly exposed to a convection process with  $T_\infty = 50^\circ\text{C}$  and  $h = 1000 \text{ W/m}^2\cdot\text{K}$ , while the other surface ( $x = 0$ ) is maintained at  $T_o$ . Also, the wall suddenly experiences uniform volumetric heating with  $\dot{q} = 1 \times 10^7 \text{ W/m}^3$ . See also Problem 2.60.

**FIND:** (a) Using spatial and time increments of  $\Delta x = 4 \text{ mm}$  and  $\Delta t = 1 \text{ s}$ , compute and plot the temperature distributions in the wall for the initial condition, the steady-state condition, and two intermediate times, and (b) On  $q_x''$ - $t$  coordinates, plot the heat flux at  $x = 0$  and  $x = L$ . At what elapsed time is there zero heat flux at  $x = L$ ?

**SCHEMATIC:**

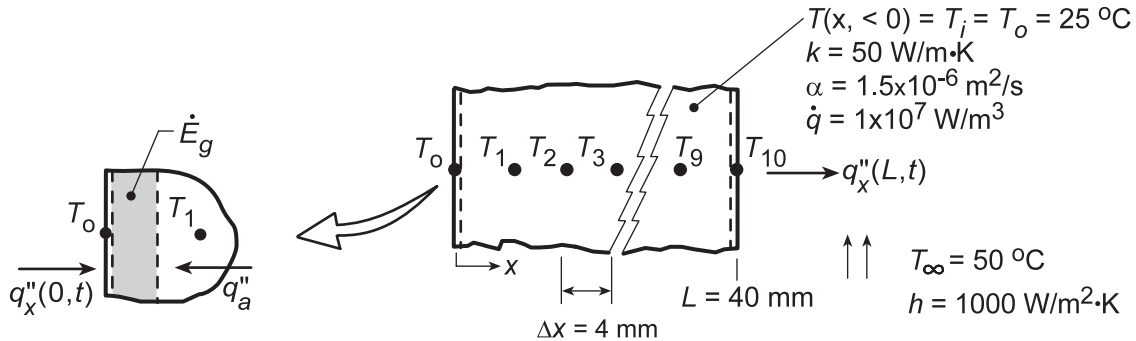

**ASSUMPTIONS:** (1) One-dimensional, transient conduction and (2) Constant properties.

**ANALYSIS:** (a) Using the *IHT Finite-Difference Equations, One-Dimensional, Transient Tool*, the temperature distributions were obtained and plotted below.

(b) The heat flux,  $q_x''(L,t)$ , can be expressed in terms of Newton's law of cooling,

$$q_x''(L,t) = h(T_{10}^p - T_\infty).$$

From the energy balance on the control volume about node 0 shown above,

$$q_x''(0,t) + \dot{E}_g + q_a'' = 0 \quad q_x''(0,t) = -\dot{q}(\Delta x/2) - k(T_1^p - T_o)/\Delta x$$

From knowledge of the temperature distribution, the heat fluxes are computed and plotted.

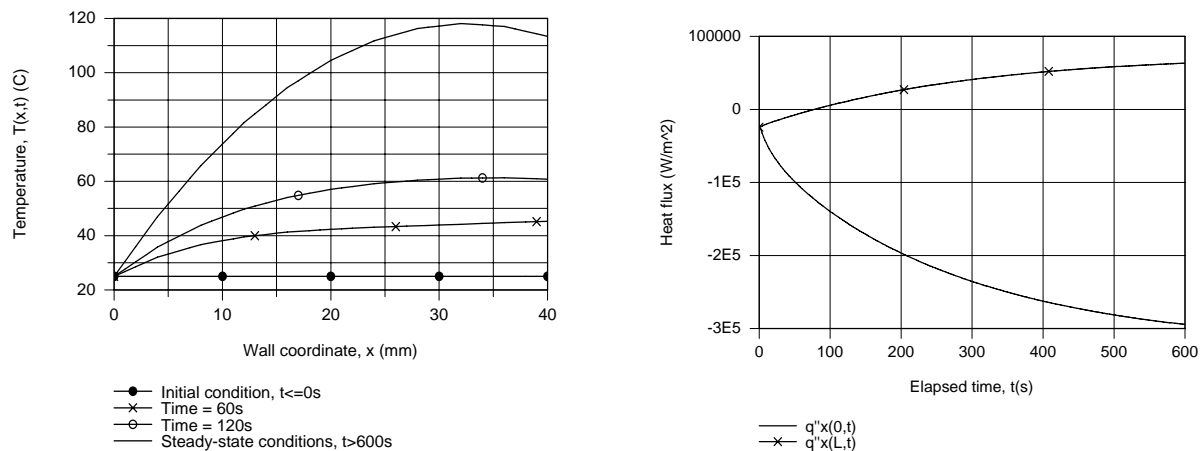

**COMMENTS:** The steady-state analytical solution has the form of Eq. 3.44 where  $C_1 = 6500 \text{ m}^{-1}\cdot\text{C}$  and  $C_2 = 25^\circ\text{C}$ . Find  $q_x''(0, \infty) = -3.25 \times 10^5 \text{ W/m}^2$  and  $q_x''(L, \infty) = +7.5 \times 10^4 \text{ W/m}^2$ . Comparing with the graphical results above, we conclude that steady-state conditions are not reached in 600 s.

### PROBLEM 5.120

**KNOWN:** Fuel element of Example 5.11 is initially at a uniform temperature of  $250^\circ\text{C}$  with no internal generation; suddenly a uniform generation,  $\dot{q} = 10^8 \text{W/m}^3$ , occurs when the element is inserted into the core while the surfaces experience convection ( $T_\infty, h$ ).

**FIND:** Temperature distribution 1.5s after element is inserted into the core.

**SCHEMATIC:**

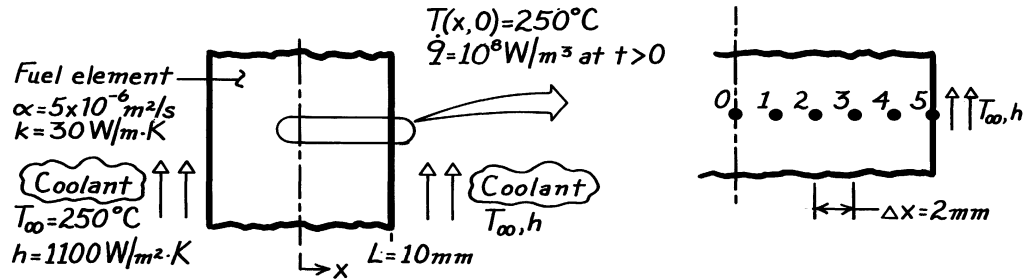

**ASSUMPTIONS:** (1) One-dimensional transient conduction, (2) Constant properties, (3)  $\dot{q} = 0$ , initially; at  $t > 0$ ,  $\dot{q}$  is uniform.

**ANALYSIS:** As suggested, the explicit method with a space increment of 2mm will be used. Using the nodal network of Example 5.11, the same finite-difference equations may be used.

*Interior nodes,  $m = 1, 2, 3, 4$*

$$T_m^{p+1} = \text{Fo} \left[ T_{m-1}^p + T_{m+1}^p + \frac{\dot{q}(\Delta x)^2}{2} \right] + (1 - 2 \text{Fo}) T_m^p. \quad (1)$$

*Midplane node,  $m = 0$*

Same as Eq. (1), but with  $T_{m-1}^p = T_{m+1}^p$ .

*Surface node,  $m = 5$*

$$T_5^{p+1} = 2 \text{Fo} \left[ T_4^p + \text{Bi} \cdot T_\infty + \frac{\dot{q}(\Delta x)^2}{2k} \right] + (1 - 2\text{Fo} - 2\text{Bi} \cdot \text{Fo}) T_5^p. \quad (2)$$

The most restrictive stability criterion is associated with Eq. (2),  $\text{Fo}(1 + \text{Bi}) \leq 1/2$ . Consider the following parameters:

$$\text{Bi} = \frac{h\Delta x}{k} = \frac{1100 \text{W/m}^2 \cdot \text{K} \times (0.002 \text{m})}{30 \text{W/m} \cdot \text{K}} = 0.0733$$

$$\text{Fo} \leq \frac{1/2}{(1 + \text{Bi})} = 0.466$$

$$\Delta t \leq \frac{\text{Fo}(\Delta x)^2}{\alpha} = 0.466 \frac{(0.002 \text{m})^2}{5 \times 10^{-6} \text{m}^2/\text{s}} = 0.373 \text{s}.$$

Continued ...

**PROBLEM 5.120 (Cont.)**

To be well within the stability limit, select  $\Delta t = 0.3s$ , which corresponds to

$$Fo = \frac{\alpha \Delta t}{\Delta x^2} = \frac{5 \times 10^{-6} \text{ m}^2 / \text{s} \times 0.3 \text{ s}}{(0.002 \text{ m})^2} = 0.375$$

$$t = p \Delta t = 0.3p \text{ (s)}.$$

Substituting numerical values with  $\dot{q} = 10^8 \text{ W/m}^3$ , the nodal equations become

$$T_0^{p+1} = 0.375 \left[ 2T_1^p + 10^8 \text{ W/m}^3 (0.002 \text{ m})^2 / 30 \text{ W/m} \cdot \text{K} \right] + (1 - 2 \times 0.375) T_0^p$$

$$T_0^{p+1} = 0.375 \left[ 2T_1^p + 13.33 \right] + 0.25 T_0^p \quad (3)$$

$$T_1^{p+1} = 0.375 \left[ T_0^p + T_2^p + 13.33 \right] + 0.25 T_1^p \quad (4)$$

$$T_2^{p+1} = 0.375 \left[ T_1^p + T_3^p + 13.33 \right] + 0.25 T_2^p \quad (5)$$

$$T_3^{p+1} = 0.375 \left[ T_2^p + T_4^p + 13.33 \right] + 0.25 T_3^p \quad (6)$$

$$T_4^{p+1} = 0.375 \left[ T_3^p + T_5^p + 13.33 \right] + 0.25 T_4^p \quad (7)$$

$$T_5^{p+1} = 2 \times 0.375 \left[ T_4^p + 0.0733 \times 250 + \frac{13.33}{2} \right] + (1 - 2 \times 0.375 - 2 \times 0.0733 \times 0.375) T_5^p$$

$$T_5^{p+1} = 0.750 \left[ T_4^p + 24.99 \right] + 0.195 T_5^p. \quad (8)$$

The initial temperature distribution is  $T_i = 250^\circ\text{C}$  at all nodes. The marching solution, following the procedure of Example 5.11, is represented in the table below.

p	t(s)	T <sub>0</sub>	T <sub>1</sub>	T <sub>2</sub>	T <sub>3</sub>	T <sub>4</sub>	T <sub>5</sub> (°C)
0	0	250	250	250	250	250	250
1	0.3	255.00	255.00	255.00	255.00	255.00	254.99
2	0.6	260.00	260.00	260.00	260.00	260.00	259.72
3	0.9	265.00	265.00	265.00	265.00	264.89	264.39
4	1.2	270.00	270.00	270.00	269.96	269.74	268.97
5	1.5	275.00	275.00	274.98	274.89	274.53	273.50

The desired temperature distribution  $T(x, 1.5s)$ , corresponds to  $p = 5$ .

**COMMENTS:** Note that the nodes near the midplane (0,1) do not feel any effect of the coolant during the first 1.5s time period.

## PROBLEM C5.121

**KNOWN:** Dimensions and properties of acrylic and steel plates. Initial temperatures.

**FIND:** Time needed to bring external surface of the acrylic to its softening temperature. Plot of the average acrylic and steel plate temperatures and acrylic surface temperature for  $0 \leq t \leq 300$  s.

**SCHEMATIC:**

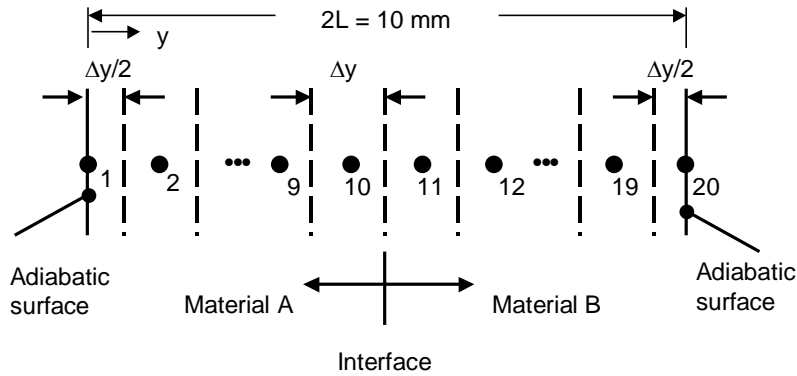

**ASSUMPTIONS:** (1) One-dimensional conduction, (2) Constant properties, (3) Negligible contact resistance.

**PROPERTIES:** Acrylic (given):  $\rho_A = 1990 \text{ kg/m}^3$ ,  $c_A = 1470 \text{ J/kg}\cdot\text{K}$  and  $k_A = 0.21 \text{ W/m}\cdot\text{K}$ . Steel (given):  $\rho_B = 7800 \text{ kg/m}^3$ ,  $c_B = 500 \text{ J/kg}\cdot\text{K}$  and  $k_B = 45 \text{ W/m}\cdot\text{K}$ .

**ANALYSIS:** We begin by writing energy balances on each of the 20 control volumes using the implicit method,

$$\text{Node 1: } \rho_A c_A \frac{\Delta y}{2} \frac{(T_1^{p+1} - T_1^p)}{\Delta t} = \frac{k_A (T_2^{p+1} - T_1^{p+1})}{\Delta y}$$

$$\text{Nodes 2 - 9: } \rho_A c_A \Delta y \frac{(T_n^{p+1} - T_n^p)}{\Delta t} = \frac{k_A (T_{n-1}^{p+1} - T_n^{p+1})}{\Delta y} + \frac{k_A (T_{n+1}^{p+1} - T_n^{p+1})}{\Delta y}$$

$$\text{Node 10: } \rho_A c_A \Delta y \frac{(T_{10}^{p+1} - T_{10}^p)}{\Delta t} = \frac{k_A (T_9^{p+1} - T_{10}^{p+1})}{\Delta y} + \frac{(T_{11}^{p+1} - T_{10}^{p+1})}{R_t''}$$

$$\text{Node 11: } \rho_B c_B \Delta y \frac{(T_{11}^{p+1} - T_{11}^p)}{\Delta t} = \frac{(T_{10}^{p+1} - T_{11}^{p+1})}{R_t''} + \frac{k_B (T_{12}^{p+1} - T_{11}^{p+1})}{\Delta y}$$

$$\text{Nodes 12 - 19: } \rho_B c_B \Delta y \frac{(T_n^{p+1} - T_n^p)}{\Delta t} = \frac{k_B (T_{n-1}^{p+1} - T_n^{p+1})}{\Delta y} + \frac{k_B (T_{n+1}^{p+1} - T_n^{p+1})}{\Delta y}$$

$$\text{Node 20: } \rho_B c_B \frac{\Delta y}{2} \frac{(T_{20}^{p+1} - T_{20}^p)}{\Delta t} = \frac{k_B (T_{19}^{p+1} - T_{20}^{p+1})}{\Delta y}$$

Continued...

**PROBLEM 5.121 (Cont.)**

where 
$$R_t'' = \frac{\Delta y/2}{k_A} + \frac{\Delta y/2}{k_B}$$

Also, note that the average temperature of each material may be written as

$$\bar{T} = \frac{1}{L} \int_{y=0}^L T(y) dy$$

or, in finite difference form,

$$\bar{T}_A = \frac{1}{L_A} \left[ T_1 \frac{\Delta y}{2} + T_2 \Delta y + T_3 \Delta y + T_4 \Delta y + T_5 \Delta y + T_6 \Delta y + T_7 \Delta y + T_8 \Delta y + T_9 \Delta y + T_{10} \Delta y \right]$$

and

$$\bar{T}_B = \frac{1}{L_B} \left[ T_{11} \Delta y + T_{12} \Delta y + T_{13} \Delta y + T_{14} \Delta y + T_{15} \Delta y + T_{16} \Delta y + T_{17} \Delta y + T_{18} \Delta y + T_{19} \Delta y + T_{20} \frac{\Delta y}{2} \right]$$

The preceding equations were solved using IHT code that is listed in the Comments. The spatially-averaged temperatures of the two plates, as well as the external temperature of the acrylic,  $T_1$ , are shown in the plot below. <

From the simulation, we also find that the surface of the acrylic reaches  $T_{\text{soft}} = 90^\circ\text{C}$  at  $t = 87$  s. <

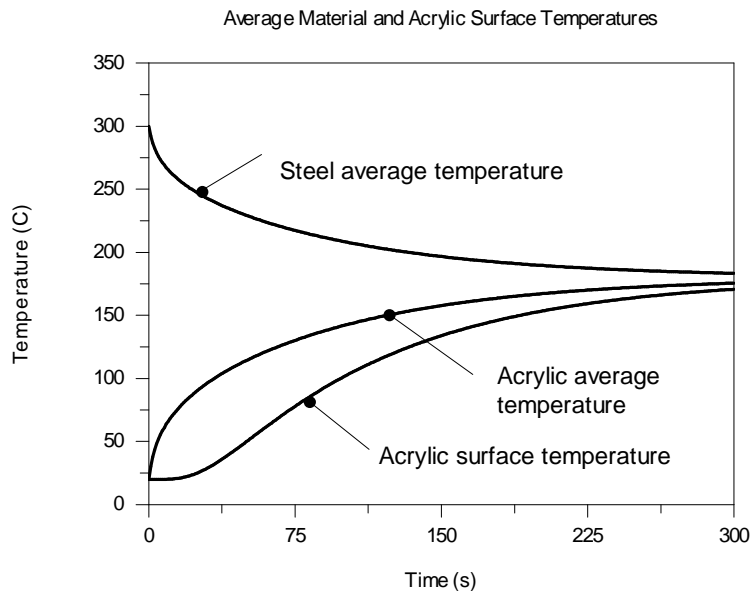

**COMMENTS:** (1) Ultimately, the temperatures of the two plates will reach the same steady-state value. The steady-state temperature may be found by recognizing the energy gained by the acrylic is lost by the steel,  $L_{AC}A(T_{ss} - T_{i,A}) = L_{BC}B(T_{i,B} - T_{ss})$  yielding  $T_{ss} = 180^\circ\text{C}$ , as evident in the plot of the average temperatures. (2) If the surface of the acrylic in contact with the metal is assumed to be of constant temperature and equal to  $300^\circ\text{C}$ , the external surface of the acrylic reaches the softening temperature at  $t = 74$  s. (3) The IHT code is shown on the next page.

Continued...

## PROBLEM 5.121 (Cont.)

//Geometry and Discretization

LA = 0.005 //m  
LB = 0.005 //m

delyA = LA/9.5 //m  
delyB = LB/9.5 //m

//Properties

kA = 0.21 //W/mK  
kB = 45 //W/mK  
cA = 1470 //J/kgK  
cB = 500 //J/kgK  
rhoA = 1990 //kg/m<sup>3</sup>  
rhoB = 7800 //kg/m<sup>3</sup>

//Initial Temperatures

TiA = 20 //C  
TiB = 300 //C

//Interface Resistance

Rt = delyA/kA/2 + delyB/kB/2

//Node 1

$\rho_A c_A \text{delyA}/2 \text{der}(T1,t) = (kA/\text{delyA}) \cdot (T2 - T1)$

//Nodes 2 through 9

$\rho_A c_A \text{delyA} \text{der}(T2,t) = (kA/\text{delyA}) \cdot (T1 - T2) + (kA/\text{delyA}) \cdot (T3 - T2)$   
 $\rho_A c_A \text{delyA} \text{der}(T3,t) = (kA/\text{delyA}) \cdot (T2 - T3) + (kA/\text{delyA}) \cdot (T4 - T3)$   
 $\rho_A c_A \text{delyA} \text{der}(T4,t) = (kA/\text{delyA}) \cdot (T3 - T4) + (kA/\text{delyA}) \cdot (T5 - T4)$   
 $\rho_A c_A \text{delyA} \text{der}(T5,t) = (kA/\text{delyA}) \cdot (T4 - T5) + (kA/\text{delyA}) \cdot (T6 - T5)$   
 $\rho_A c_A \text{delyA} \text{der}(T6,t) = (kA/\text{delyA}) \cdot (T5 - T6) + (kA/\text{delyA}) \cdot (T7 - T6)$   
 $\rho_A c_A \text{delyA} \text{der}(T7,t) = (kA/\text{delyA}) \cdot (T6 - T7) + (kA/\text{delyA}) \cdot (T8 - T7)$   
 $\rho_A c_A \text{delyA} \text{der}(T8,t) = (kA/\text{delyA}) \cdot (T7 - T8) + (kA/\text{delyA}) \cdot (T9 - T8)$   
 $\rho_A c_A \text{delyA} \text{der}(T9,t) = (kA/\text{delyA}) \cdot (T8 - T9) + (kA/\text{delyA}) \cdot (T10 - T9)$

//Node 10

$\rho_A c_A \text{delyA} \text{der}(T10,t) = (kA/\text{delyA}) \cdot (T9 - T10) + (1/Rt) \cdot (T11 - T10)$

//Node 11

$\rho_B c_B \text{delyB} \text{der}(T11,t) = (1/Rt) \cdot (T10 - T11) + (kB/\text{delyB}) \cdot (T12 - T11)$

//Nodes 12 through 19

$\rho_B c_B \text{delyB} \text{der}(T12,t) = (kB/\text{delyB}) \cdot (T11 - T12) + (kB/\text{delyB}) \cdot (T13 - T12)$   
 $\rho_B c_B \text{delyB} \text{der}(T13,t) = (kB/\text{delyB}) \cdot (T12 - T13) + (kB/\text{delyB}) \cdot (T14 - T13)$   
 $\rho_B c_B \text{delyB} \text{der}(T14,t) = (kB/\text{delyB}) \cdot (T13 - T14) + (kB/\text{delyB}) \cdot (T15 - T14)$   
 $\rho_B c_B \text{delyB} \text{der}(T15,t) = (kB/\text{delyB}) \cdot (T14 - T15) + (kB/\text{delyB}) \cdot (T16 - T15)$   
 $\rho_B c_B \text{delyB} \text{der}(T16,t) = (kB/\text{delyB}) \cdot (T15 - T16) + (kB/\text{delyB}) \cdot (T17 - T16)$   
 $\rho_B c_B \text{delyB} \text{der}(T17,t) = (kB/\text{delyB}) \cdot (T16 - T17) + (kB/\text{delyB}) \cdot (T18 - T17)$   
 $\rho_B c_B \text{delyB} \text{der}(T18,t) = (kB/\text{delyB}) \cdot (T17 - T18) + (kB/\text{delyB}) \cdot (T19 - T18)$   
 $\rho_B c_B \text{delyB} \text{der}(T19,t) = (kB/\text{delyB}) \cdot (T18 - T19) + (kB/\text{delyB}) \cdot (T20 - T19)$

//Node 20

$\rho_B c_B (\text{delyB}/2) \text{der}(T20,t) = (kB/\text{delyB}) \cdot (T19 - T20)$

//Average Temperatures

$\text{TavgA} \cdot LA = T1 \cdot \text{delyA}/2 + T2 \cdot \text{delyA} + T3 \cdot \text{delyA} + T4 \cdot \text{delyA} + T5 \cdot \text{delyA} + T6 \cdot \text{delyA} + T7 \cdot \text{delyA} + T8 \cdot \text{delyA} + T9 \cdot \text{delyA} + T10 \cdot \text{delyA}$

$\text{TavgB} \cdot LB = T11 \cdot \text{delyB} + T12 \cdot \text{delyB} + T13 \cdot \text{delyB} + T14 \cdot \text{delyB} + T15 \cdot \text{delyB} + T16 \cdot \text{delyB} + T17 \cdot \text{delyB} + T18 \cdot \text{delyB} + T19 \cdot \text{delyB} + T20 \cdot \text{delyB}/2$

//Steady State Temperature

$LA \cdot c_A \cdot \rho_A \cdot (TiA - Tss) = LB \cdot c_B \cdot \rho_B \cdot (Tss - TiB)$



### PROBLEM 5.122

**KNOWN:** Conditions associated with heat generation in a rectangular fuel element with surface cooling. See Example 5.11.

**FIND:** (a) The temperature distribution 1.5 s after the change in operating power; compare your results with those tabulated in the example, (b) Calculate and plot temperature histories at the mid-plane (00) and surface (05) nodes for  $0 \leq t \leq 400$  s; determine the new steady-state temperatures, and approximately how long it will take to reach the new steady-state condition after the step change in operating power. Use the IHT Tools | *Finite-Difference Equations* | *One-Dimensional* | *Transient* conduction model builder as your solution tool.

**SCHEMATIC:**

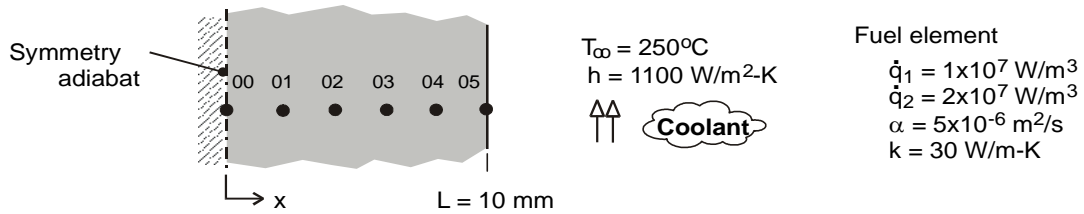

**ASSUMPTIONS:** (1) One dimensional conduction in the x-direction, (2) Uniform generation, and (3) Constant properties.

**ANALYSIS:** The IHT model builder provides the transient finite-difference equations for the implicit method of solution. Selected portions of the IHT code used to obtain the results tabulated below are shown in the Comments.

(a) Using the IHT code, the temperature distribution ( $^{\circ}\text{C}$ ) as a function of time (s) up to 1.5 s after the step power change is obtained from the summarized results copied into the workspace

	t	T00	T01	T02	T03	T04	T05
1	0	357.6	356.9	354.9	351.6	346.9	340.9
2	0.3	358.1	357.4	355.4	352.1	347.4	341.4
3	0.6	358.6	357.9	355.9	352.6	347.9	341.9
4	0.9	359.1	358.4	356.4	353.1	348.4	342.3
5	1.2	359.6	358.9	356.9	353.6	348.9	342.8
6	1.5	360.1	359.4	357.4	354.1	349.3	343.2

(b) Using the code, the mid-plane (00) and surface (05) node temperatures are plotted as a function of time.

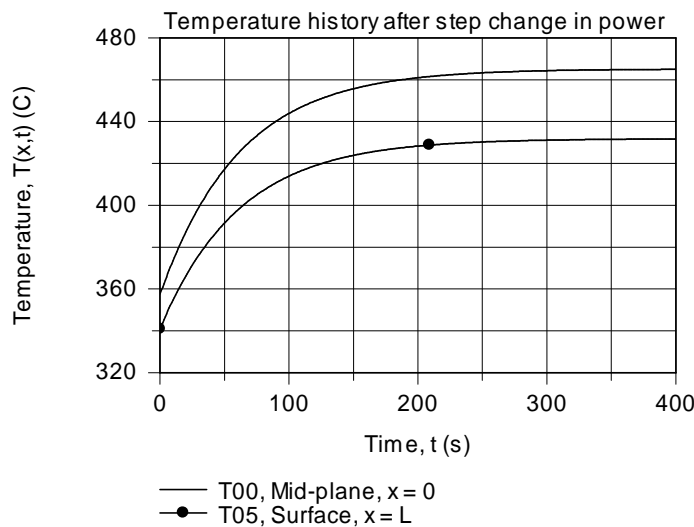

Continued ...

## PROBLEM 5.122 (Cont.)

Note that at  $t \approx 240$  s, the wall has nearly reached the new steady-state condition for which the nodal temperatures ( $^{\circ}\text{C}$ ) were found as:

T00	T01	T02	T03	T04	T05
465	463.7	459.7	453	443.7	431.7

**COMMENTS:** (1) Can you validate the new steady-state nodal temperatures from part (b) by comparison against an analytical solution?

(2) Will using a smaller time increment improve the accuracy of the results? Use your code with  $\Delta t = 0.15$  s to justify your explanation.

(3) Selected portions of the IHT code to obtain the nodal temperature distribution using spatial and time increments of  $\Delta x = 2$  mm and  $\Delta t = 0.3$  s, respectively, are shown below. For the solve-integration step, the initial condition for each of the nodes corresponds to the steady-state temperature distribution with  $\dot{q}_1$ .

```

// Tools | Finite-Difference Equations | One-Dimensional | Transient
/* Node 00: surface node (w-orientation); transient conditions; e labeled 01. */
rho * cp * der(T00,t) = fd_1d_sur_w(T00,T01,k,qdot,deltax,Tinf01,h01,q"a00)
q"a00 = 0 // Applied heat flux, W/m^2; zero flux shown
Tinf01 = 20 // Arbitrary value
h01 = 1e-8 // Causes boundary to behave as adiabatic
/* Node 01: interior node; e and w labeled 02 and 00. */
rho*cp*der(T01,t) = fd_1d_int(T01,T02,T00,k,qdot,deltax)
/* Node 02: interior node; e and w labeled 03 and 01. */
rho*cp*der(T02,t) = fd_1d_int(T02,T03,T01,k,qdot,deltax)
/* Node 03: interior node; e and w labeled 04 and 02. */
rho*cp*der(T03,t) = fd_1d_int(T03,T04,T02,k,qdot,deltax)
/* Node 04: interior node; e and w labeled 05 and 03. */
rho*cp*der(T04,t) = fd_1d_int(T04,T05,T03,k,qdot,deltax)
/* Node 05: surface node (e-orientation); transient conditions; w labeled 04. */
rho * cp * der(T05,t) = fd_1d_sur_e(T05,T04,k,qdot,deltax,Tinf05,h05,q"a05)
q"a05 = 0 // Applied heat flux, W/m^2; zero flux shown
Tinf05 = 250 // Coolant temperature, C
h05 = 1100 // Convection coefficient, W/m^2.K

// Input parameters
qdot = 2e7 // Volumetric rate, W/m^3, step change
deltax = 0.002 // Space increment
k = 30 // Thermophysical properties
alpha = 5e-6
rho = 1000
alpha = k / (rho * cp)

/* Steady-state conditions, with qdot1 = 1e7 W/m^3; initial conditions for step change
T_x = 16.67 * (1 - x^2/L^2) + 340.91 // See text
Seek T_x for x = 0, 2, 4, 6, 8, 10 mm; results used for Ti are
Node T_x
00 357.6
01 356.9
02 354.9
03 351.6
04 346.9
05 340.9 */

```

### PROBLEM 5.123

**KNOWN:** Thickness, initial temperature, speed and thermophysical properties of steel in a thin-slab continuous casting process. Surface convection conditions.

**FIND:** Time required to cool the outer surface to a prescribed temperature. Corresponding value of the midplane temperature and length of cooling section.

**SCHEMATIC:**

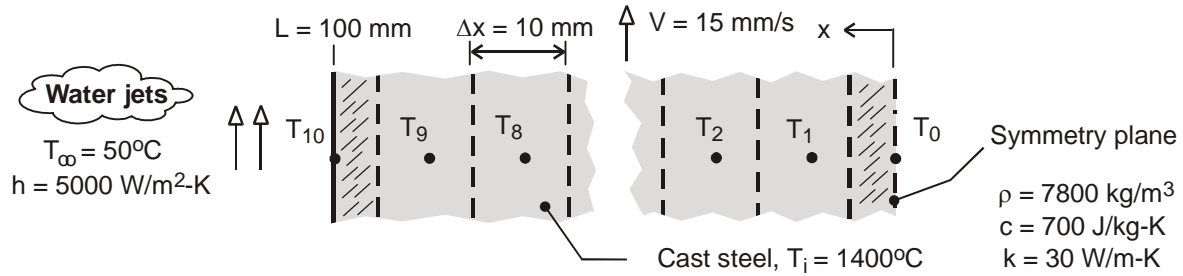

**ASSUMPTIONS:** (1) One-dimensional conduction, (2) Negligible radiation at quenched surfaces, (3) Symmetry about the midplane, (4) Constant properties.

**ANALYSIS:** Adopting the implicit scheme, the finite-difference equation for the cooled surface node is given by Eq. (5.96), from which it follows that

$$(1 + 2Fo + 2FoBi)T_{10}^{p+1} - 2FoT_9^{p+1} = 2FoBiT_{\infty} + T_{10}^p$$

The general form of the finite-difference equation for any interior node (1 to 9) is given by Eq. (5.97),

$$(1 + 2Fo)T_m^{p+1} - Fo(T_{m-1}^{p+1} + T_{m+1}^{p+1}) = T_m^p$$

The finite-difference equation for the midplane node may be obtained by applying the symmetry requirement to Eq. (5.94); that is,  $T_{m+1}^p = T_{m-1}^p$ . Hence,

$$(1 + 2Fo)T_0^{p+1} - 2FoT_1^{p+1} = T_0^p$$

For the prescribed conditions,  $Bi = h\Delta x/k = 5000 \text{ W/m}^2 \cdot \text{K} (0.010\text{m})/30 \text{ W/m} \cdot \text{K} = 1.67$ . If the explicit method were used, the stability requirement would be given by Eq. (5.87). Hence, for  $Fo(1 + Bi) \leq 0.5$ ,  $Fo \leq 0.187$ . With  $Fo = \alpha\Delta t/\Delta x^2$  and  $\alpha = k/\rho c = 5.49 \times 10^{-6} \text{ m}^2/\text{s}$ , the corresponding restriction on the time increment would be  $\Delta t \leq 3.40\text{s}$ . Although no such restriction applies for the implicit method, a value of  $\Delta t = 1\text{s}$  is chosen, and the set of 11 finite-difference equations is solved using the *Tools* option designated as *Finite-Difference Equations, One-Dimensional and Transient* from the IHT Toolpad. For  $T_{10}(t) = 300^\circ\text{C}$ , the solution yields

$$t = 161\text{s}$$

<

Continued ...

### PROBLEM 5.123 (Cont.)

$$T_0(t) = 1364^\circ\text{C}$$

&lt;

With a casting speed of  $V = 15 \text{ mm/s}$ , the length of the cooling section is

$$L_{\text{CS}} = Vt = 0.015 \text{ m/s}(161\text{s}) = 2.42\text{m}$$

&lt;

**COMMENTS:** (1) With  $Fo = \alpha t/L^2 = 0.088 < 0.2$ , the one-term approximation to the exact solution for one-dimensional conduction in a plane wall cannot be used to confirm the foregoing results. However, using the exact solution from the *Models, Transient Conduction, Plane Wall* Option of IHT, values of  $T_0 = 1366^\circ\text{C}$  and  $T_s = 200.7^\circ\text{C}$  are obtained and are in good agreement with the finite-difference predictions. The accuracy of these predictions could still be improved by reducing the value of  $\Delta x$ .

(2) Temperature histories for the surface and midplane nodes are plotted for  $0 < t < 600\text{s}$ .

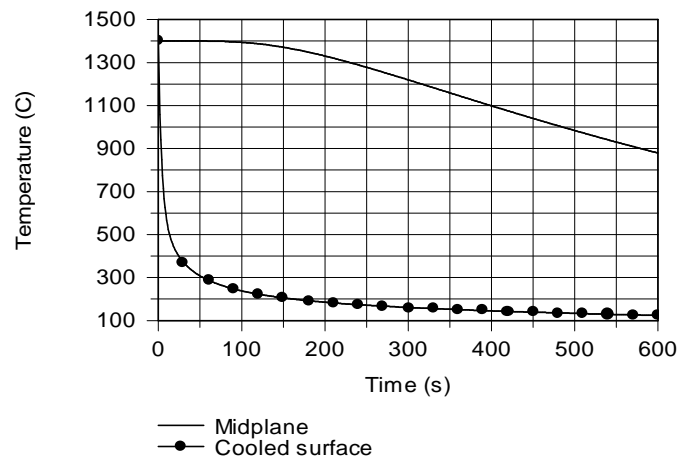

While  $T_{10}(600\text{s}) = 124^\circ\text{C}$ ,  $T_0(600\text{s})$  has only dropped to  $879^\circ\text{C}$ . The much slower thermal response at the midplane is attributable to the small value of  $\alpha$  and the large value of  $Bi = 16.67$ .

### PROBLEM 5.124

**KNOWN:** Thickness and thermal diffusivity of a plane wall. Initial and boundary conditions.

**FIND:** (a) Temperature distribution at  $t = 30$  min using an explicit finite difference technique with a time step of 600 s and a space increment of 30 mm. (b) Temperature distribution at  $t = 30$  min using an implicit finite difference technique with a time step of 600 s and a space increment of 30 mm.

**SCHEMATIC:**

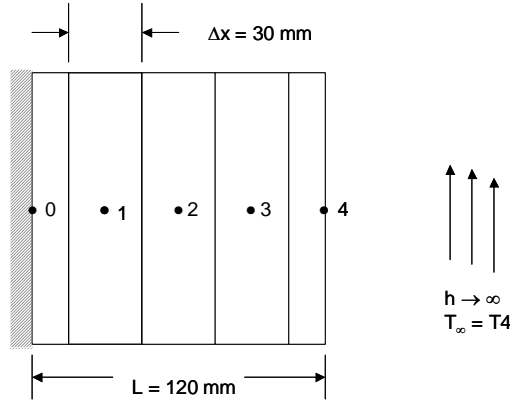

**ASSUMPTIONS:** (1) One-dimensional heat transfer, (2) Constant properties.

**PROPERTIES:** Thermal diffusivity,  $\alpha = 1.5 \times 10^{-6}$  m<sup>2</sup>/s (given).

**ANALYSIS:** (a) The finite-difference equations for the interior points, nodes 0, 1, 2 and 3, can be determined from Eq. 5.81,

$$T_m^{p+1} = Fo(T_{m-1}^p + T_{m+1}^p) + (1 - 2Fo)T_m^p \quad (1)$$

The Fourier number is

$$Fo = \alpha \Delta t / \Delta x^2 = 1.5 \times 10^{-6} \text{ m}^2 / \text{s} \times 600 \text{ s} / (0.03 \text{ m})^2 = 1 \quad (2)$$

Note that the stability criterion of Eq. 5.82 is *not* satisfied. Nonetheless, we will combine Eqs. (1) and (2) to yield

$$T_m^{p+1} = T_{m-1}^p + T_{m+1}^p - T_m^p$$

Since the adiabatic surface at  $x = 0$  can be treated as a symmetry plane, we note that  $T_{m-1} = T_{m+1}$  for node 0. The finite-difference solution is shown in the table below.

$p$	$t$ (min)	$T_0$	$T_1$	$T_2$	$T_3$	$T_4 = T_\infty$ (°C)
0	0	85	85	85	85	20
1	10	85	85	85	20	20
2	20	85	85	20	85	20
3	30	85	20	150	-45	20

<  
Continued...

### PROBLEM 5.124 (Cont.)

(b) Note that for this solution, the conditions at the right face have been incorporated by specifying a very large convection coefficient at the right face so that  $T_4 \approx T_\infty$ . The *IHT* code is shown in the COMMENTS section. The following results were obtained.

$p$	$t$ (min)	$T_0$	$T_1$	$T_2$	$T_3$	$T_4 = T_\infty$ (°C)
0	0	85	85	85	85	20
1	10	82.2	80.9	75.3	60.1	20
2	20	77.3	74.8	66.3	48.8	20
3	30	71.4	68.5	59.1	42.7	20

<

**COMMENTS:** (1) The *IHT* Code for part (b) is shown at the end of the Comments. (2) Note the thermal response of part (a) is unrealistic. This unrealistic result is expected since the stability criterion is not satisfied. (3) Part (b) was repeated with a smaller time step of  $\Delta t = 300$  s yielding the following results. Note that these results differ from those associated with the larger time step. Just because the implicit finite-difference method is inherently *stable*, the solutions may still be dependent upon the time step and, as such, are incorrect.

$p$	$t$ (min)	$T_0$	$T_1$	$T_2$	$T_3$	$T_4 = T_\infty$ (°C)
0	0	85	85	85	85	20
1	10	82.8	81.2	74.8	57.5	20
2	20	77.7	74.8	65.3	46.9	20
3	30	71.3	68.1	58.1	41.4	20

```
/* Node 0: surface node (w-orientation); transient conditions; e labeled 1. */
rho * cp * der(T0,t) = fd_1d_sur_w(T0,T1,k,qdot,deltax,Tinf,h1,qfla0)
```

```
/* Node 1: interior node; e and w labeled e and 0. */
rho*cp*der(T1,t) = fd_1d_int(T1,T2,T0,k,qdot,deltax)
```

```
/* Node 2: interior node; e and w labeled 3 and 1. */
rho*cp*der(T2,t) = fd_1d_int(T2,T3,T1,k,qdot,deltax)
```

```
/* Node 3: interior node; e and w labeled 4 and 2. */
rho*cp*der(T3,t) = fd_1d_int(T3,T4,T2,k,qdot,deltax)
```

```
/* Node 4: surface node (e-orientation); transient conditions; w labeled 3. */
rho * cp * der(T4,t) = fd_1d_sur_e(T4,T3,k,qdot,deltax,Tinf,h2,qfla4)
```

```
Tinf = 20           //Initial Conditions are T = 85 everywhere (C)
h1 = 0             //Insulated left wall
h2 = 1e10          //Right wall at Tinf since h2 is nearly infinite
qfla0 = 0          //Zero applied heat flux at left wall
qfla4 = 0          //Zero applied heat flux at right wall
deltax = 30/1000   //meters
qdot = 0           //W/m^3
```

```
// Set k, rho and cp values so that alpha = 1.5*10^-6 m2/s
k = 1.5e-6         //W/m-K
rho = 1            //kg
cp = 1             //J/kg-K
```

### PROBLEM 5.125

**KNOWN:** Very thick plate, initially at a uniform temperature,  $T_i$ , is suddenly exposed to a convection cooling process ( $T_\infty, h$ ).

**FIND:** Temperatures at the surface and a 45mm depth after 3 minutes using finite-difference method with space and time increments of 15mm and 18s.

**SCHEMATIC:**

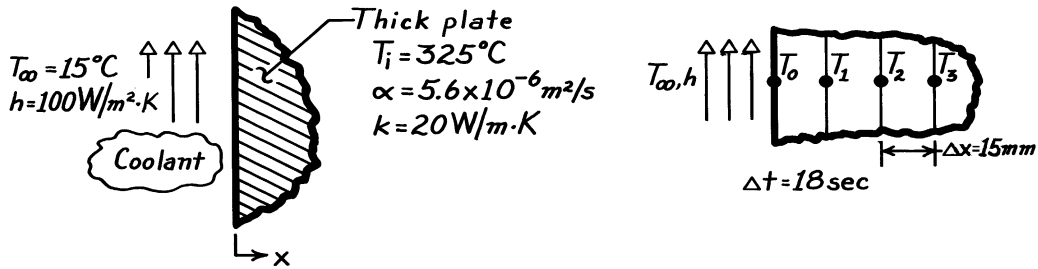

**ASSUMPTIONS:** (1) One-dimensional transient conduction, (2) Plate approximates semi-infinite medium, (3) Constant properties.

**ANALYSIS:** The grid network representing the plate is shown above. The finite-difference equation for node 0 is given by Eq. 5.90 for one-dimensional conditions or Eq. 5.85,

$$T_0^{P+1} = 2 \text{Fo} (T_1^P + \text{Bi} \cdot T_\infty) + (1 - 2 \text{Fo} - 2 \text{Bi} \cdot \text{Fo}) T_0^P. \quad (1)$$

The numerical values of Fo and Bi are

$$\text{Fo} = \frac{\alpha \Delta t}{\Delta x^2} = \frac{5.6 \times 10^{-6} \text{ m}^2 / \text{s} \times 18 \text{ s}}{(0.015 \text{ m})^2} = 0.448$$

$$\text{Bi} = \frac{h \Delta x}{k} = \frac{100 \text{ W/m}^2 \cdot \text{K} \times (15 \times 10^{-3} \text{ m})}{20 \text{ W/m} \cdot \text{K}} = 0.075.$$

Recognizing that  $T_\infty = 15^\circ\text{C}$ , Eq. (1) has the form

$$T_0^{P+1} = 0.0359 T_0^P + 0.897 T_1^P + 1.01. \quad (2)$$

It is important to satisfy the stability criterion,  $\text{Fo} (1 + \text{Bi}) \leq 1/2$ . Substituting values,  $0.448 (1 + 0.075) = 0.482 \leq 1/2$ , and the criterion is satisfied.

The finite-difference equation for the interior nodes,  $m = 1, 2, \dots$ , follows from Eq. 5.78,

$$T_m^{P+1} = \text{Fo} (T_{m+1}^P + T_{m-1}^P) + (1 - 2\text{Fo}) T_m^P. \quad (3)$$

Recognizing that the stability criterion,  $\text{Fo} \leq 1/2$ , is satisfied with  $\text{Fo} = 0.448$ ,

$$T_m^{P+1} = 0.448 (T_{m+1}^P + T_{m-1}^P) + 0.104 T_m^P. \quad (4)$$

Continued ...

**PROBLEM 5.125 (Cont.)**

The time scale is related to  $p$ , the number of steps in the calculation procedure, and  $\Delta t$ , the time increment,

$$t = p\Delta t. \quad (5)$$

The finite-difference calculations can now be performed using Eqs. (2) and (4). The results are tabulated below.

$p$	$t(s)$	$T_0$	$T_1$	$T_2$	$T_3$	$T_4$	$T_5$	$T_6$	$T_7(K)$
0	0	325	325	325	325	325	325	325	325
1	18	304.2	324.7	325	325	325	325	325	325
2	36	303.2	315.3	324.5	325	325	325	325	325
3	54	294.7	313.7	320.3	324.5	325	325	325	325
4	72	293.0	307.8	318.9	322.5	324.5	325	325	325
5	90	287.6	305.8	315.2	321.5	323.5	324.5	325	325
6	108	285.6	301.6	313.5	319.3	322.7	324.0	324.5	325
7	126	281.8	299.5	310.5	317.9	321.4	323.3	324.2	
8	144	279.8	296.2	308.6	315.8	320.4	322.5		
9	162	276.7	294.1	306.0	314.3	319.0			
10	180	274.8	291.3	304.1	312.4				

Hence, find

$$T(0, 180s) = T_0^{10} = 275^\circ\text{C} \quad T(45\text{mm}, 180s) = T_3^{10} = 312^\circ\text{C}. \quad <$$

**COMMENTS:** (1) The above results can be readily checked against the analytical solution represented in Fig. 5.8 (see also Eq. 5.63). For  $x = 0$  and  $t = 180s$ , find

$$\frac{x}{2(\alpha t)^{1/2}} = 0$$

$$\frac{h(\alpha t)^{1/2}}{k} = \frac{100 \text{ W/m}^2 \cdot \text{K} \left( 5.60 \times 10^{-6} \text{ m}^2/\text{s} \times 180\text{s} \right)^{1/2}}{20 \text{ W/m} \cdot \text{K}} = 0.16$$

for which the figure gives

$$\frac{T - T_i}{T_\infty - T_i} = 0.15$$

so that,

$$T(0, 180s) = 0.15(T_\infty - T_i) + T_i = 0.15(15 - 325)^\circ\text{C} + 325^\circ\text{C}$$

$$T(0, 180s) = 278^\circ\text{C}.$$

For  $x = 45\text{mm}$ , the procedure yields  $T(45\text{mm}, 180s) = 316^\circ\text{C}$ . The agreement with the numerical solution is nearly within 1%.



### PROBLEM 5.126

**KNOWN:** Sudden exposure of the surface of a thick slab, initially at a uniform temperature, to convection and to surroundings at a high temperature.

**FIND:** (a) Explicit, finite-difference equation for the surface node in terms of  $Fo$ ,  $Bi$ ,  $Bi_r$ , (b) Stability criterion; whether it is more restrictive than that for an interior node and does it change with time, and (c) Temperature at the surface and at 30mm depth for prescribed conditions after 1 minute exposure.

**SCHEMATIC:**

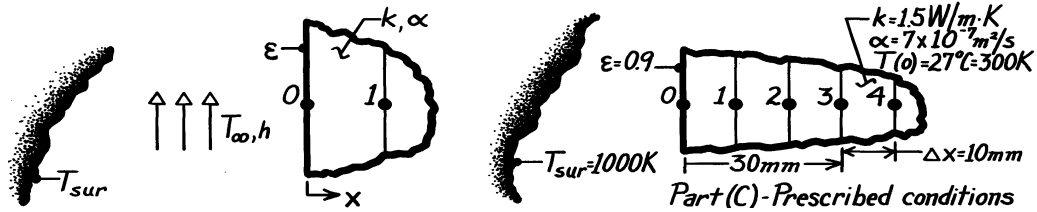

**ASSUMPTIONS:** (1) One-dimensional transient conduction, (2) Thick slab may be approximated as semi-infinite medium, (3) Constant properties, (4) Radiation exchange is between small surface and large surroundings.

**ANALYSIS:** (a) The explicit form of the FDE for the surface node may be obtained by applying an energy balance to a control volume about the node.

$$\begin{aligned} \dot{E}_{in}'' - \dot{E}_{out}'' &= q_{conv}'' + q_{rad}'' + q_{cond}'' = \dot{E}_{st}'' \\ h(T_{\infty} - T_0^p) + h_r(T_{sur} - T_0^p) + k \cdot 1 \cdot \frac{T_1^p - T_0^p}{\Delta x} \\ &= \rho c \left[ \frac{\Delta x}{2} \cdot 1 \right] \frac{T_0^{p+1} - T_0^p}{\Delta t} \quad (1) \end{aligned}$$

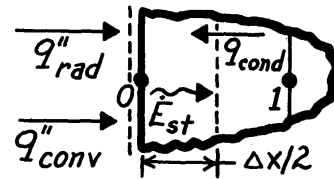

where the radiation process has been linearized, Eq. 1.9.

$$h_r = h_r^p(T_0^p, T_{sur}) = \varepsilon \sigma (T_0^p + T_{sur}) \left( \left[ T_0^p \right]^2 + T_{sur}^2 \right) \quad (2)$$

Divide Eq. (1) by  $\rho c \Delta x / 2 \Delta t$  and regroup using these definitions to obtain the FDE:

$$Fo \equiv (k/\rho c) \Delta t / \Delta x^2 \quad Bi \equiv h \Delta x / k \quad Bi_r \equiv h_r \Delta x / k \quad (3,4,5)$$

$$T_0^{p+1} = 2Fo \left( Bi \cdot T_{\infty} + Bi_r \cdot T_{sur} + T_1^p \right) + (1 - 2Bi \cdot Fo - 2Bi_r \cdot Fo - 2Fo) T_0^p \quad (6) <$$

(b) The stability criterion for Eq. (6) requires that the coefficient of  $T_0^p$  be positive.

$$1 - 2Fo(Bi + Bi_r + 1) \geq 0 \quad \text{or} \quad Fo \leq 1/2(Bi + Bi_r + 1) \quad (7) <$$

The stability criterion for an interior node, Eq. 5.82, is  $Fo \leq 1/2$ . Since  $Bi + Bi_r > 0$ , the stability criterion of the surface node is more restrictive. Note that  $Bi_r$  is not constant but depends upon  $h_r$  which increases with increasing  $T_0^p$  (time). Hence, the restriction on  $Fo$  increases with increasing  $T_0^p$  (time).

Continued ...

**PROBLEM 5.126 (Cont.)**

(c) Consider the prescribed conditions with negligible convection ( $Bi = 0$ ). The FDEs for the thick slab are:

$$\text{Surface } (0) \quad T_0^{p+1} = 2Fo \left( Bi \cdot Fo + Bi_r \cdot T_{sur} + T_1^p \right) + (1 - 2Bi \cdot Fo - 2Bi_r \cdot Fo - 2Fo) T_0^p \quad (8)$$

$$\text{Interior } (m \geq 1) \quad T_m^{p+1} = Fo \left( T_{m+1}^p + T_{m-1}^p \right) + (1 - 2Fo) T_m^p \quad (9,5,7,3)$$

The stability criterion from Eq. (7) with  $Bi = 0$  is,

$$Fo \leq 1/2(1 + Bi_r) \quad (10)$$

To proceed with the explicit, marching solution, we need to select a value of  $\Delta t$  ( $Fo$ ) that will satisfy the stability criterion. A few trial calculations are helpful. A value of  $\Delta t = 15s$  provides  $Fo = 0.105$ , and using Eqs. (2) and (5),  $h_r(300K, 1000K) = 72.3 \text{ W/m}^2 \cdot K$  and  $Bi_r = 0.482$ . From the stability criterion, Eq. (10), find  $Fo \leq 0.337$ . With increasing  $T_0^p$ ,  $h_r$  and  $Bi_r$  increase:  $h_r(800K, 1000K) = 150.6 \text{ W/m}^2 \cdot K$ ,  $Bi_r = 1.004$  and  $Fo \leq 0.249$ . Hence, if  $T_0^p < 800K$ ,  $\Delta t = 15s$  or  $Fo = 0.105$  satisfies the stability criterion.

Using  $\Delta t = 15s$  or  $Fo = 0.105$  with the FDEs, Eqs. (8) and (9), the results of the solution are tabulated below. Note how  $h_r^p$  and  $Bi_r^p$  are evaluated at each time increment. Note that  $t = p \cdot \Delta t$ , where  $\Delta t = 15s$ .

p	t(s)	$T_0 / h_r^p / Bi_r$	T1(K)	T2	T3	T4	....
0	0	300 72.3 0.482	300	300	300	300	
1	15	370.867 79.577 0.5305	300	300	300	300	
2	30	426.079 85.984 0.5733	307.441	300	300	300	
3	45	470.256 91.619 0.6108	319.117	300.781	300	300	
4	60	502.289	333.061	302.624	300.082	300	

After 60s ( $p = 4$ ),  $T_0(0, 1 \text{ min}) = 502.3K$  and  $T_3(30mm, 1 \text{ min}) = 300.1K$ . <

**COMMENTS:** (1) The form of the FDE representing the surface node agrees with Eq. 5.90 if this equation is reduced to one-dimension.

(2) We should recognize that the  $\Delta t = 15s$  time increment represents a coarse step. To improve the accuracy of the solution, a smaller  $\Delta t$  should be chosen.

### PROBLEM 5.127

**KNOWN:** One-dimensional convective heating and cooling of a plane slab with  $Bi_1 = 10$  (for Heating Phase 1, beginning at  $Fo = 0$  and ending at  $Fo = Fo_1 = 0.1$ ),  $Bi_2 = 1$  (for Cooling Phase 2, beginning at  $Fo = Fo_1$ ).

**FIND:** (a) Dimensionless form of the heat equation, initial and boundary conditions for Phase 1, (b) Dimensionless form of the heat equation, initial and boundary conditions for Phase 2, (c) Finite difference solution for  $\theta_0^*(x^* = 1, Fo)$ ,  $\theta_0^*(x^* = 0, Fo)$  and  $\theta_0^*(x^* = 0.5, Fo)$  for  $Fo_1 = 0.1$  over the range  $0 \leq Fo \leq 0.5$  using  $\Delta x^* = 0.1$  and  $\Delta Fo = 0.001$ , (d) Value of and time associated with the minimum dimensionless temperature at the midplane of the wall.

**SCHEMATIC:**

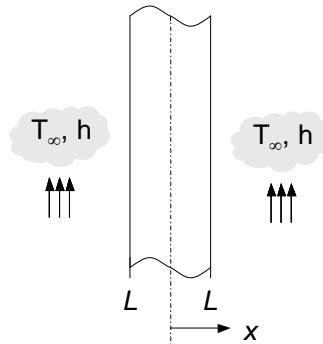

**ASSUMPTIONS:** (1) One-dimensional conduction, (2) Constant properties.

**ANALYSIS:** (a) The dimensionless forms of the heat equation, initial and boundary conditions for Phase 1 are given by Eqs. 5.37 through 5.40,

$$\frac{\partial^2 \theta^*}{\partial x^{*2}} = \frac{\partial \theta^*}{\partial Fo} \quad ; \quad \theta^*(x^*, 0) = 1 \quad ; \quad \left. \frac{\partial \theta^*}{\partial x^*} \right|_{x^*=0} = 0 \quad ; \quad \left. \frac{\partial \theta^*}{\partial x^*} \right|_{x^*=1} = -Bi_1 \theta^*(1, Fo) \quad <$$

where  $\theta^* = (T - T_{\infty,1}) / (T_i - T_{\infty,1})$ ,  $x^* = x/L$ ,  $Fo = \alpha t / L^2$  and  $Bi_1 = h_1 L / k$ .

(b) For cooling (Phase 2), the dimensionless form of the heat equation and the boundary condition at  $x^* = 0$  are unchanged from part (a). However, the initial condition for Phase 2 is the temperature distribution that exists at the conclusion of Phase 1,  $\theta^*(x^*, Fo = Fo_1)$  and the boundary condition at  $x^* = 1$  is derived beginning with the energy balance at the  $x^* = 1$  control surface, <

$$-k \left. \frac{\partial T}{\partial x} \right|_{x=L} = h_2 [T(L, t) - T_{\infty,2}] = h_2 [T(L, t) - T_i]$$

Substituting the expressions  $T = \theta^*(T_i - T_{\infty,1}) + T_{\infty,1}$  and  $x = x^* L$  into the preceding equation yields

$$-k \frac{\partial [T_{\infty,1} + \theta^*(T_i - T_{\infty,1})]}{\partial (x^* L)} = h_2 [T_{\infty,1} + \theta^*(T_i - T_{\infty,1}) - T_i]$$

which may be simplified to

Continued...

**PROBLEM 5.127 (Cont.)**

$$\begin{aligned} \frac{\partial \theta^*}{\partial x^*} &= -\frac{h_2 L}{k(T_i - T_{\infty,1})} \left[ (T_{\infty,1} - T_i) + \theta^* (T_i - T_{\infty,1}) \right] \\ &= -\frac{h_2 L}{k} [\theta^* - 1] = Bi_2 [1 - \theta^*] \end{aligned}$$

<

(c) The dimensionless form of the energy equation, based upon the discretization shown below, was solved using IHT software. The IHT code is included in the comments.

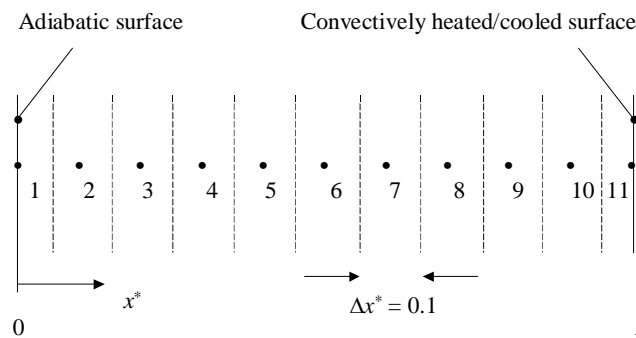

The thermal response is shown in the graph below.

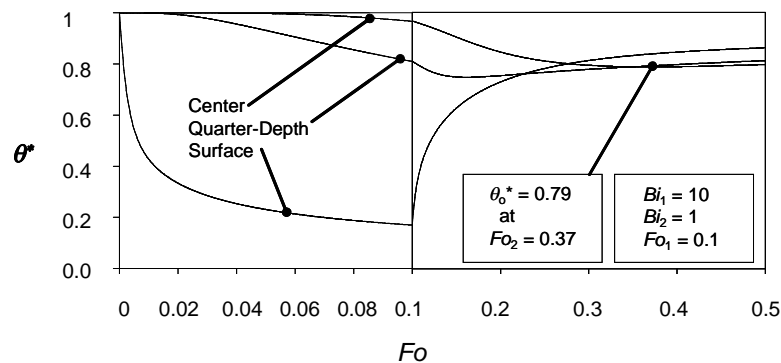

Note that the surface heats quickly in Phase 1 ( $\theta^*$  decreases rapidly) while the center midplane temperature changes only slightly over the heating time. The quarter plane (or quarter depth) temperature increases at an intermediate rate during heating. During cooling (Phase 2), the surface cools rapidly, but, as noted during heating, it takes some time for inner regions of the wall to begin changing in temperature in response to the new boundary conditions. Warm temperatures in the inner regions of the wall continue to propagate to the midplane, increasing its temperature until a maximum temperature is reached. The cooling response is slower than the heating response since  $Bi_2 < Bi_1$ . Ultimately (not shown), the entire wall will return to its initial temperature of  $\theta^* = 1$ .

(d) The minimum dimensionless temperature at the midplane may be determined by inspecting the predictions of the finite difference model. The minimum midplane temperature is  $\theta^* = 0.79$ , and occurs at  $Fo = Fo_2 = 0.37$ , as shown in the figure of part (c).

Continued...

## PROBLEM 5.127 (Cont.)

**COMMENTS:** (1) The IHT code used in part (c) is listed below.

```
// Boundary Conditions.

Bi1 = 10
Bi2 = 1

//Initial Conditions.

//Initial Conditions for Phase 1 Heating

// Set all initial dimensionless temperatures to thN = 1 for N = 1 //through 11 in IHT solver.

//Initial Conditions for Phase 2 Cooling

//Set the initial conditions (at Fo = Fo1 = 0.1) equal to the predicted //temperatures from Phase
//1 Heating simulation at Fo1 = 0.1.

//Control volume size.

dx = 0.1

//Node 1 is at the midplane.
//Node 11 is at the surface.
//Write energy balances for Nodes 1 through 10.

//Node 1
(th2 - th1)/dx = (dx/2)*der(th1,Fo)

//Node 2
(th1 - th2)/dx + (th3 - th2)/dx = (dx)*der(th2,Fo)

//Node 3
(th2 - th3)/dx + (th4 - th3)/dx = (dx)*der(th3,Fo)

//Node 4
(th3 - th4)/dx + (th5 - th4)/dx = (dx)*der(th4,Fo)

//Node 5
(th4 - th5)/dx + (th6 - th5)/dx = (dx)*der(th5,Fo)

//Node 6
(th5 - th6)/dx + (th7 - th6)/dx = (dx)*der(th6,Fo)

//Node 7
(th6 - th7)/dx + (th8 - th7)/dx = (dx)*der(th7,Fo)

//Node 8
(th7 - th8)/dx + (th9 - th8)/dx = (dx)*der(th8,Fo)

//Node 9
(th8 - th9)/dx + (th10 - th9)/dx = (dx)*der(th9,Fo)

//Node 10
(th9 - th10)/dx + (th11 - th10)/dx = (dx)*der(th10,Fo)

//Energy balance for Node 11 for Phase 1 Heating.
//Enable in Phase 1. Disable in Phase 2.

(th10 - th11)/dx - Bi1*th11 = (dx/2)*der(th11,Fo)

//Energy balance for Node 11 for Phase 2 Cooling.
//Disable for Phase 1. Enable for Phase 2.

((th10 - th11)/dx - Bi2*(th11 - 1) = (dx/2)*der(th11,Fo)
```

Continued...

### PROBLEM 5.127 (Cont.)

- (2) If one is interested in determining the maximum midplane temperature in response to heating, recognize that this maximum value does not occur at the moment heating is stopped. In this problem, the increase in the midplane temperature from the onset of heating to the curtailment of heating is  $\Delta\theta^*(x^* = 0, Fo_1 = 0.1) = 0.033$  whereas the maximum change in the midplane temperature is  $\Delta\theta^*(x^* = 0, Fo_2 = 0.37) = 0.212$  which is 6 times larger than the increase at  $Fo_1$ . Furthermore, maximum midplane temperatures are reached long after heating is stopped and cooling begins ( $Fo_2/Fo_1 = 3.7$ ). (3) The effects illustrated in this problem, specifically the continued heating of inner regions of the wall and the long time delay before maximum wall temperatures are reached after heating has stopped and cooling has begun, are important in many applications including materials processing, food processing and thermal sterilization, and structural response (building collapse) to fire long after the fire is extinguished. (4) See Bergman, "Extreme Midplane Wall Temperatures due to Sequential Heating and Cooling, *ASME Journal of Heat Transfer*, vol. 130, pp. 094503-1 to 094503-4, 2008 for more information.

### PROBLEM 5.128

**KNOWN:** Thick slab of copper, initially at a uniform temperature, is suddenly exposed to a constant net radiant flux at one surface. See Example 5.12.

**FIND:** (a) The nodal temperatures at nodes 00 and 04 at  $t = 120$  s; that is,  $T_{00}(0, 120 \text{ s})$  and  $T_{04}(0.15 \text{ m}, 120 \text{ s})$ ; compare results with those given by the exact solution in Comment 1; will a time increment of 0.12 s provide more accurate results?; and, (b) Plot the temperature histories for  $x = 0, 150$  and  $600$  mm, and explain key features of your results. Use the *IHT Tools / Finite-Difference Equations / One-Dimensional / Transient* conduction model builder to obtain the implicit form of the FDEs for the interior nodes. Use space and time increments of 37.5 mm and 1.2 s, respectively, for a 17-node network. For the surface node 00, use the FDE derived in Section 2 of the Example.

**SCHEMATIC:**

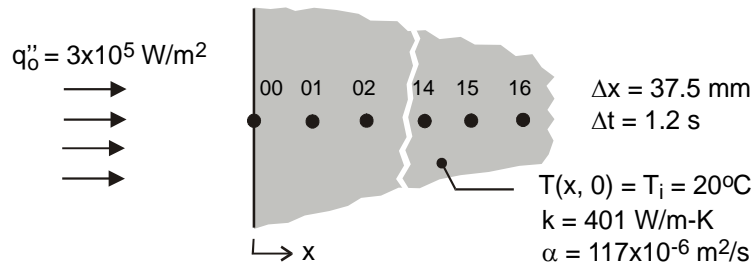

**ASSUMPTIONS:** (1) One-dimensional conduction in the  $x$ -direction, (2) Slab of thickness 600 mm approximates a semi-infinite medium, and (3) Constant properties.

**ANALYSIS:** The IHT model builder provides the implicit-method FDEs for the interior nodes, 01 – 15. The  $+x$  boundary condition for the node-16 control volume is assumed adiabatic. The FDE for the surface node 00 exposed to the net radiant flux was derived in the Example analysis. Selected portions of the IHT code used to obtain the following results are shown in the Comments.

(a) The 00 and 04 nodal temperatures for  $t = 120$  s are tabulated below using a time increment of  $\Delta t = 1.2$  s and 0.12 s, and compared with the results given from the exact analytical solution, Eq. 5.62.

Node	FDE results ( $^{\circ}\text{C}$ )		Analytical result ( $^{\circ}\text{C}$ )
	$\Delta t = 1.2 \text{ s}$	$\Delta t = 0.12 \text{ s}$	
00	119.3	119.4	Eq. 5.59 120.0
04	45.09	45.10	45.4

The numerical FDE-based results with the different time increments agree quite closely with one another. At the surface, the numerical results are nearly  $1^{\circ}\text{C}$  less than the result from the exact analytical solution. This difference represents an error of  $-1\%$  ( $-1^{\circ}\text{C} / (120 - 20)^{\circ}\text{C} \times 100$ ). At the  $x = 150$  mm location, the difference is about  $-0.4^{\circ}\text{C}$ , representing an error of  $-1.5\%$ . For this situation, the smaller time increment (0.12 s) did not provide improved accuracy. To improve the accuracy of the numerical model, it would be necessary to reduce the space increment, in addition to using the smaller time increment.

(b) The temperature histories for  $x = 0, 150$  and  $600$  mm (nodes 00, 04, and 16) for the range  $0 \leq t \leq 150$  s are as follows.

Continued ...

## PROBLEM 5.128 (Cont.)

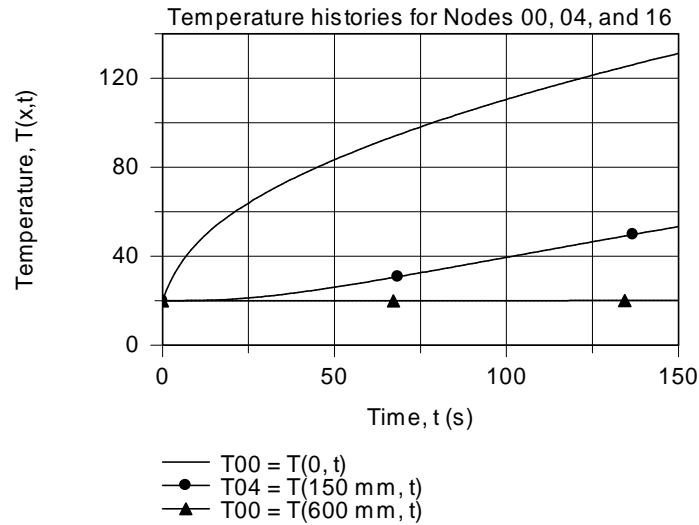

As expected, the surface temperature,  $T00 = T(0, t)$ , increases markedly at early times. As thermal penetration increases with increasing time, the temperature at the location  $x = 150$  mm,  $T04 = T(150$  mm,  $t)$ , begins to increase after about 20 s. Note, however, the temperature at the location  $x = 600$  mm,  $T16 = T(600$  mm,  $t)$ , does not change significantly within the 150 s duration of the applied surface heat flux. Our assumption of treating the  $+x$  boundary of the node 16 control volume as adiabatic is justified. A copper plate of 600-mm thickness is a good approximation to a semi-infinite medium at times less than 150 s.

**COMMENTS:** Selected portions of the *IHT* code with the nodal equations to obtain the temperature distribution are shown below. Note how the FDE for node 00 is written in terms of an energy balance using the  $der(T, t)$  function. The FDE for node 16 assumes that the “east” boundary is adiabatic.

```
// Finite-difference equation, node 00; from Examples solution derivation; implicit method
q''o + k * (T01 - T00) / deltax = rho * (deltax / 2) * cp * der (T00,t)
```

```
// Finite-difference equations, interior nodes 01-15; from Tools
```

```
/* Node 01: interior node; e and w labeled 02 and 00. */
rho*cp*der(T01,t) = fd_1d_int(T01,T02,T00,k,qdot,deltax)
rho*cp*der(T02,t) = fd_1d_int(T02,T03,T01,k,qdot,deltax)
.....
rho*cp*der(T14,t) = fd_1d_int(T14,T15,T13,k,qdot,deltax)
rho*cp*der(T15,t) = fd_1d_int(T15,T16,T14,k,qdot,deltax)
```

```
// Finite-difference equation node 16; from Tools, adiabatic surface
```

```
/* Node 16: surface node (e-orientation); transient conditions; w labeled 15. */
rho * cp * der(T16,t) = fd_1d_sur_e(T16,T15,k,qdot,deltax,Tinf16,h16,q''a16)
q''a16 = 0 // Applied heat flux, W/m^2; zero flux shown
Tinf16 = 20 // Arbitrary value
h16 = 1e-8 // Causes boundary to behave as adiabatic
```



### PROBLEM 5.129

**KNOWN:** Plane wall of thickness  $2L$ , initially at a uniform temperature, is suddenly subjected to convection heat transfer.

**FIND:** The mid-plane,  $T(0,t)$ , and surface,  $T(L,t)$ , temperatures at  $t = 50, 100, 200$  and  $500$  s, using the following methods: (a) the one-term series solution; determine also the Biot number; (b) the lumped capacitance solution; and (c) the two- and 5-node finite-difference numerical solutions. Prepare a table summarizing the results and comment on the relative differences of the predicted temperatures.

**SCHEMATIC:**

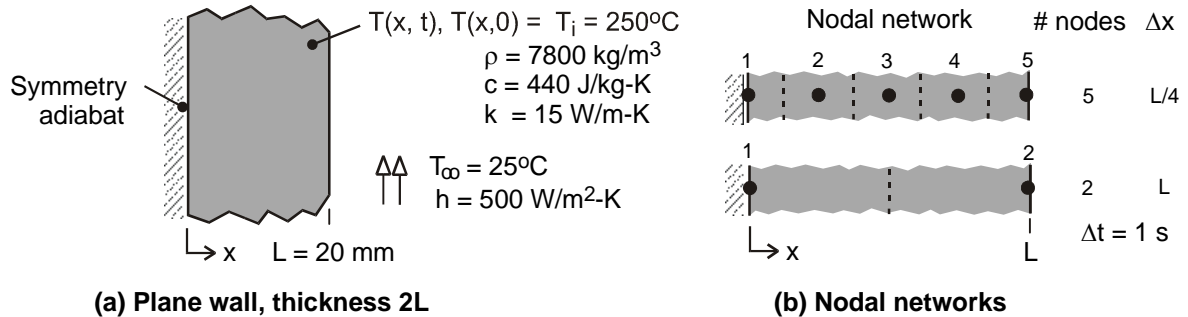

**ASSUMPTIONS:** (1) One-dimensional conduction in the  $x$ -direction, and (2) Constant properties.

**ANALYSIS:** (a) The results are tabulated below for the mid-plane and surface temperatures using the one-term approximation to the series solution, Eq. 5.43 and 5.44. The Biot number for the heat transfer process is

$$Bi = h L / k = 500 \text{ W/m}^2 \cdot \text{K} \times 0.020 \text{ m} / 15 \text{ W/m} \cdot \text{K} = 0.67$$

Since  $Bi \gg 0.1$ , we expect an appreciable temperature difference between the mid-plane and surface, as the tabulated results indicate.

(b) The results are tabulated below for the wall temperatures using the lumped capacitance method (LCM) of solution, Eq. 5.6. The LCM neglects the internal conduction resistance and since  $Bi = 0.67 \gg 0.1$ , we expect this method to predict systematically lower temperatures (faster cooling) at the midplane compared to the one-term approximation.

Solution method/Time(s)	50	100	200	500
<b>Mid-plane, <math>T(0,t)</math> (°C)</b>				
One-term, Eqs. 5.43, 5.44	207.1	160.5	99.97	37.70
Lumped capacitance	181.7	133.9	77.69	30.97
2-node FDE	210.6	163.5	100.5	37.17
5-node FDE	207.5	160.9	100.2	37.77
<b>Surface, <math>T(L,t)</math> (°C)</b>				
One-term, Eqs. 5.43, 5.44	160.1	125.4	80.56	34.41
Lumped capacitance	181.7	133.9	77.69	30.97
2-node FDE	163.7	125.2	79.40	33.77
5-node FDE	160.2	125.6	80.67	34.45

(c) The 2- and 5-node nodal networks representing the wall are shown in the schematic above. The implicit form of the finite-difference equations for the mid-plane, interior (if present) and surface nodes can be derived from energy balances on the nodal control volumes. The time-rate of change of the temperature is expressed in terms of the *IHT* integral intrinsic function,  $der(T,t)$ .

Continued ...

## PROBLEM 5.129 (Cont.)

Mid-plane node

$$k(T_2 - T_1) / \Delta x = \rho c (\Delta x / 2) \cdot \text{der}(T_1, t)$$

Interior node (5-node network)

$$k(T_1 - T_2) / \Delta x + k(T_3 - T_2) / \Delta x = \rho c \Delta x \cdot \text{der}(T_2, t)$$

Surface node (shown for 5-node network)

$$k(T_4 - T_5) / \Delta x + h(T_{\text{inf}} - T_5) = \rho c (\Delta x / 2) \cdot \text{der}(T_5, t)$$

With appropriate values for  $\Delta x$ , the foregoing FDEs were entered into the *IHT* workspace and solved for the temperature distributions as a function of time over the range  $0 \leq t \leq 500$  s using an integration time step of 1 s. Selected portions of the *IHT* codes for each of the models are shown in the Comments. The results of the analysis are summarized in the foregoing table.

**COMMENTS:** (1) Referring to the table above, we can make the following observations about the relative differences and similarities of the estimated temperatures: (a) The one-term series model estimates are the most reliable, and can serve as the benchmark for the other model results; (b) The LCM model over estimates the rate of cooling, and poorly predicts temperatures since the model neglects the effect of internal resistance and  $Bi = 0.67 \gg 0.1$ ; (c) The 5-node model results are in excellent agreement with those from the one-term series solution; we can infer that the chosen space and time increments are sufficiently small to provide accurate results; and (d) The 2-node model under estimates the rate of cooling for early times when the time-rate of change is high; but for late times, the agreement is improved.

(2) See the *Solver / Intrinsic Functions* section of *IHT/Help* or the *IHT Examples* menu (Example 5.3) for guidance on using the  $\text{der}(T, t)$  function.

(3) Selected portions of the *IHT* code for the 2-node network model are shown below.

```
// Writing the finite-difference equations – 2-node model
// Node 1
k * (T2 - T1) / deltax = rho * cp * (deltax / 2) * der(T1,t)
// Node 2
k * (T1 - T2) / deltax + h * (Tinf - T2) = rho * cp * (deltax / 2) * der(T2,t)

// Input parameters
L = 0.020
deltax = L
rho = 7800 // density, kg/m^3
cp = 440 // specific heat, J/kg.K
k = 15 // thermal conductivity, W/m.K
h = 500 // convection coefficient, W/m^2.K
Tinf = 25 // fluid temperature, K
```

(4) Selected portions of the *IHT* code for the 5-node network model are shown below.

```
// Writing the finite-difference equations – 5-node model
// Node 1 - midplane
k * (T2 - T1) / deltax = rho * cp * (deltax / 2) * der(T1,t)
// Interior nodes
k * (T1 - T2) / deltax + k * (T3 - T2) / deltax = rho * cp * deltax * der(T2,t)
k * (T2 - T3) / deltax + k * (T4 - T3) / deltax = rho * cp * deltax * der(T3,t)
k * (T3 - T4) / deltax + k * (T5 - T4) / deltax = rho * cp * deltax * der(T4,t)
// Node5 - surface
k * (T4 - T5) / deltax + h * (Tinf - T5) = rho * cp * (deltax / 2) * der(T5,t)

// Input parameters
L = 0.020
deltax = L / 4
.....
.....
```

### PROBLEM 5.130

**KNOWN:** Dimensions and properties of a steel-reinforced concrete pillar. Initial, ambient and surroundings temperatures. Values of convection heat transfer coefficient and contact resistance.

**FIND:** (a) Temperature of the exposed concrete surface and the center of the steel plate at  $t = 10,000$  s without contact resistance, maximum and minimum concrete and steel temperatures for  $0 \leq t \leq 10,000$  s, (b) same as (a) but with contact resistance, (c) critical times associated with maximum steel temperatures, value of the maximum steel temperature, for cases with and without thermal contact resistance, after the fire is extinguished.

**SCHEMATIC:**

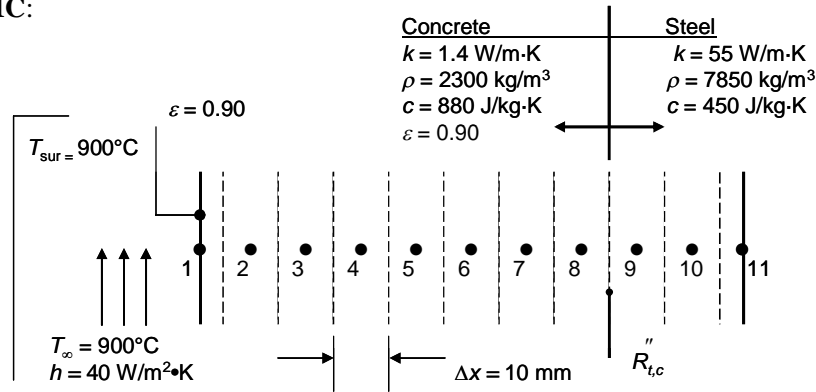

**ASSUMPTIONS:** (1) One-dimensional conduction, (2) Constant properties.

**ANALYSIS:** We begin by writing energy balances on each of the 11 control volumes, taking advantage of the symmetry of the problem,

$$\text{Node 1: } \rho_c c_c \frac{\Delta x}{2} \frac{(T_1^{p+1} - T_1^p)}{\Delta t} = (h + h_r)(T_\infty - T_1^{p+1}) + \frac{k_c(T_2^{p+1} - T_1^{p+1})}{\Delta x}$$

$$\text{where } h_r = \varepsilon \sigma (T_{\text{sur}} + T_1^{p+1}) \left( T_{\text{sur}}^2 + [T_1^{p+1}]^2 \right) \text{ and } T_{\text{sur}} = T_\infty.$$

$$\text{Nodes 2 - 7: } \rho_c c_c \Delta x \frac{(T_i^{p+1} - T_i^p)}{\Delta t} = \frac{k_c(T_{i-1}^{p+1} - T_i^{p+1})}{\Delta x} + \frac{k_c(T_{i+1}^{p+1} - T_i^{p+1})}{\Delta x}$$

$$\text{Node 8: } \rho_c c_c \Delta x \frac{(T_8^{p+1} - T_8^p)}{\Delta t} = \frac{(T_9^{p+1} - T_8^{p+1})}{R''_{\text{tot}}} + \frac{k_c(T_7^{p+1} - T_8^{p+1})}{\Delta x}$$

$$\text{where } R''_{\text{tot}} = \frac{\Delta x/2}{k_c} + \frac{\Delta x/2}{k_s} + R''_{t,c}$$

$$\text{Node 9: } \rho_s c_s \Delta x \frac{(T_9^{p+1} - T_9^p)}{\Delta t} = \frac{(T_8^{p+1} - T_9^{p+1})}{R''_{\text{tot}}} + \frac{k_s(T_{10}^{p+1} - T_9^{p+1})}{\Delta x}$$

Continued...

**PROBLEM 5.130 (Cont.)**

Node 10: 
$$\rho_s c_s \Delta x \frac{(T_{10}^{p+1} - T_{10}^p)}{\Delta t} = \frac{k_s (T_9^{p+1} - T_{10}^{p+1})}{\Delta x} + \frac{k_s (T_{11}^{p+1} - T_{10}^{p+1})}{\Delta x}$$

Node 11: 
$$\rho_s c_s \frac{\Delta x}{2} \frac{(T_{11}^{p+1} - T_{11}^p)}{\Delta t} = \frac{k_s (T_{10}^{p+1} - T_{11}^{p+1})}{\Delta x}$$

IHT is used to solve the equations; the IHT code is included in the Comments. Note that the expression  $(T_i^{p+1} - T_i^p)/\Delta t$  in the preceding equations is expressed as  $\text{der}(T_i, t)$  in the IHT code.

(a) Solving the finite difference equations without the contact resistance results in the following values at  $t = 10,000$  s.

$$T_1 = 1155 \text{ K} = 882^\circ\text{C}, T_{11} = 867 \text{ K} = 594^\circ\text{C}$$

<

**Min. & Max. Concrete & Steel Temperatures**

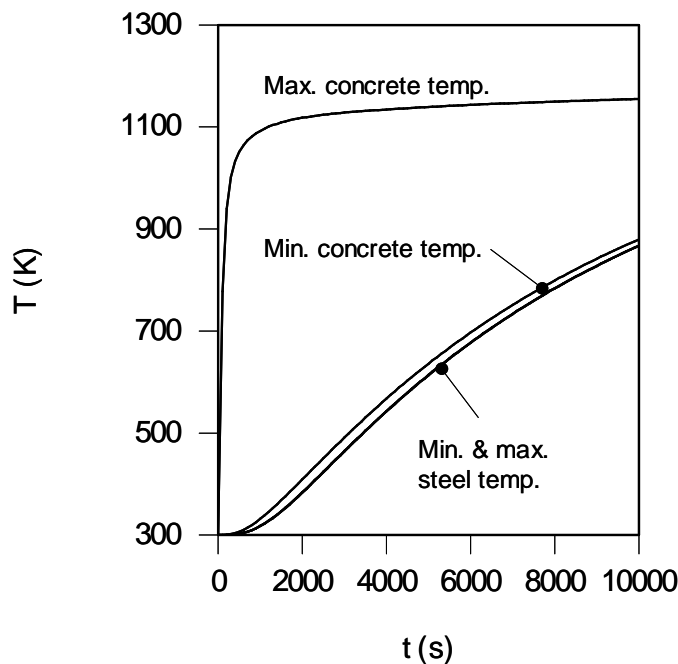

Due to the high thermal conductivity of the steel, the steel is of nearly uniform temperature, with local values varying to within one degree Celsius at any time. There is a large temperature difference between the minimum and maximum concrete temperatures.

(b) Including the contact resistance value of  $R''_{t,c} = 0.20 \text{ m}^2 \cdot \text{K}/\text{W}$  yields, at  $t = 10,000$  s,

$$T_1 = 1162 \text{ K} = 889^\circ\text{C}, T_{11} = 504 \text{ K} = 231^\circ\text{C}$$

<

Continued...

**PROBLEM 5.130 (Cont.)**

Min. & Max. Concrete & Steel Temperatures

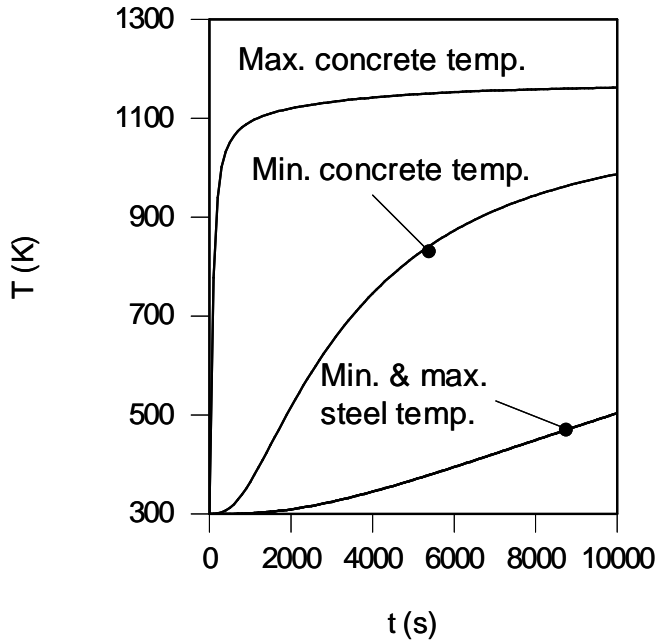

Again, due to the high thermal conductivity of the steel, the steel is isothermal to within one degree Celsius at any time. There is a large temperature difference between the minimum and maximum concrete temperatures. The temperature difference across the contact resistance is significant resulting in much lower steel temperatures than in part (a).

(c) Using the nodal temperatures at  $t = 10,000$ s as initial values, the simulation is repeated with  $T_\infty = T_{sur} = 300$ K, yielding the following results without and with the thermal contact resistance, respectively. The critical times are  $t_{crit,wo} = 11,100$ s with  $T_{steel, max, w} = 890.6$ K =  $617.5^\circ$ C and  $t_{crit,w} = 16,000$ s with  $T_{steel, max, w} = 578.7$ K =  $305.7^\circ$ C with the contact resistance. <

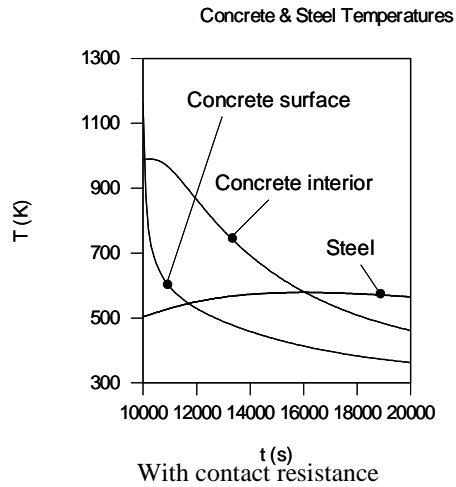
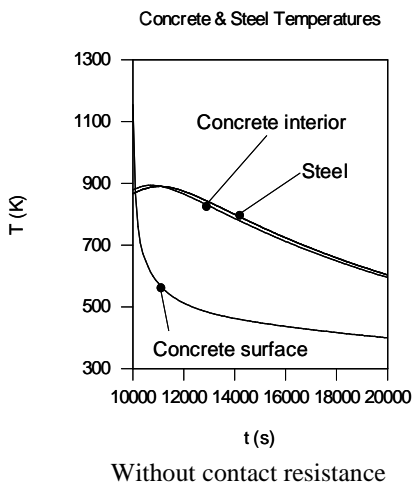

Continued...

## PROBLEM 5.130 (Cont.)

**COMMENTS:** (1) The IHT code for parts (a) and (b) is shown below.

```
//Convection and radiation parameters
hc = 40 //W/m^2K
eps = 0.90
sigma=5.67e-8 //W/m^2K^4

//Geometrical parameters
deltax = 0.010

//Ambient and surroundings temperature
Tinf = 900 + 273 //K

//Concrete properties
kc = 1.4 //W/mK
rhoc = 2300 //kg/m^3
cpc = 880 //J/kgK

//Steel properties
ks = 55 //W/mK
rhos = 7850 //kg/m^3
cps = 450 //J/kgK

//Contact resistance
R"cont = 0.2 //m^2K/W

//Nodal Equations
//Node 1
rhoc*cpc*(deltax/2)*der(T1,t) = h*(Tinf - T1)+(kc/deltax)*(T2 - T1)
h = hc + sigma*eps*(T1 + Tinf)*(T1^2 + Tinf^2)

//Node 2
rhoc*cpc*deltax*der(T2,t) = (kc/deltax)*(T1 - T2) + (kc/deltax)*(T3 - T2)

//Node 3
rhoc*cpc*deltax*der(T3,t) = (kc/deltax)*(T2 - T3) + (kc/deltax)*(T4 - T3)

//Node 4
rhoc*cpc*deltax*der(T4,t) = (kc/deltax)*(T3 - T4) + (kc/deltax)*(T5 - T4)

//Node 5
rhoc*cpc*deltax*der(T5,t) = (kc/deltax)*(T4 - T5) + (kc/deltax)*(T6 - T5)

//Node 6
rhoc*cpc*deltax*der(T6,t) = (kc/deltax)*(T5 - T6) + (kc/deltax)*(T7 - T6)

//Node 7
rhoc*cpc*deltax*der(T7,t) = (kc/deltax)*(T6 - T7) + (kc/deltax)*(T8 - T7)
```

Continued...

### PROBLEM 5.130 (Cont.)

```

//Node 8
rho*cpc*deltax*der(T8,t) = (kc/deltax)*(T7 - T8) + (T9 - T8)/Rtot
Rtot = deltax/2/kc + deltax/2/ks + R"cont

//Node 9
rho*cps*deltax*der(T9,t) = (T8 - T9)/Rtot + (ks/deltax)*(T10 - T9)

//Node 10
rho*cps*deltax*der(T10,t) = (ks/deltax)*(T9 - T10) + (ks/deltax)*(T11 - T10)

//Node 11
rho*cps*(deltax/2)*der(T11,t) =(ks/deltax)*(T10 - T11)

```

(2). The influence of the thermal contact resistance is significant in terms of both the maximum steel temperatures, as well as the critical time at which the maximum steel temperatures occur. (3) With or without the contact resistance, the maximum steel temperatures occur well after the fire is extinguished, as warm temperatures stored within the concrete slowly propagate into the steel plate. Firefighters need to be very cautious entering the building after the fire is extinguished, since structural failure may occur many hours after the fire is extinguished. (3) The minimum concrete temperature is actually equal to the maximum steel temperature in part (a). The difference between the two quantities, evident in the plot, would decrease as the spatial resolution of the simulation is increased. (5) Nodal temperatures (K) at  $t = 10,000$  s are as follows.

Node	1	2	3	4	5	6	7	8	9	10	11
<i>Without Contact Resistance</i>											
	1155	1108	1063	1019	979	941	908	879	867.4	867.0	866.9
<i>With Contact Resistance</i>											
	1162	1133	1105	1078	1052	1028	1007	987	503.9	503.7	503.6

### PROBLEM 5.131

**KNOWN:** Plastic film on metal strip initially at 25°C is heated by a laser (85,000 W/m<sup>2</sup> for Δt<sub>on</sub> = 10 s), to cure adhesive; convection conditions for ambient air at 25°C with coefficient of 100 W/m<sup>2</sup>·K.

**FIND:** Temperature histories at center and film edge, T(0,t) and T(x<sub>1</sub>,t), for 0 ≤ t ≤ 30 s, using an implicit, finite-difference method with Δx = 4mm and Δt = 1 s; determine whether adhesive is cured (T<sub>c</sub> ≥ 90°C for Δt<sub>c</sub> = 10s) and whether the degradation temperature of 200°C is exceeded.

**SCHEMATIC:**

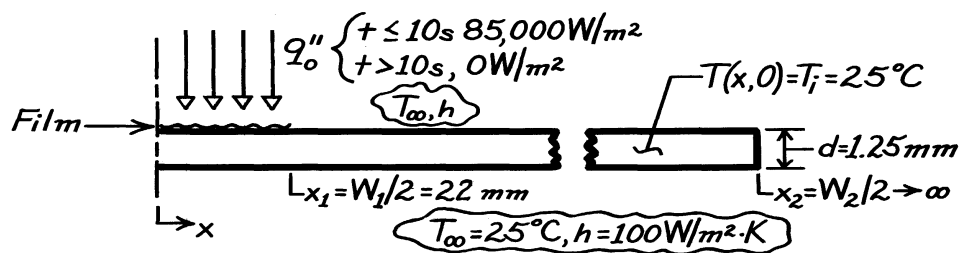

**ASSUMPTIONS:** (1) One-dimensional conduction, (2) Constant properties, (3) Uniform convection coefficient on upper and lower surfaces, (4) Thermal resistance and mass of plastic film are negligible, (5) All incident laser flux is absorbed.

**PROPERTIES:** Metal strip (given): ρ = 7850 kg/m<sup>3</sup>, c<sub>p</sub> = 435 J/kg·K, k = 60 W/m·K, α = k/ρc<sub>p</sub> = 1.757 × 10<sup>-5</sup> m<sup>2</sup>/s.

**ANALYSIS:** (a) Using a space increment of Δx = 4mm, set up the nodal network shown below. Note that the film half-length is 22mm (rather than 20mm as in Problem 3.115).

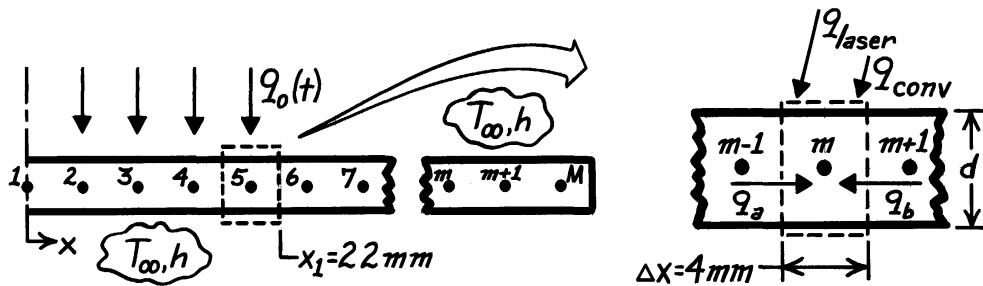

Consider the general control volume and use the conservation of energy requirement to obtain the finite-difference equation.

$$\dot{E}_{\text{in}} - \dot{E}_{\text{out}} = \dot{E}_{\text{st}}$$

$$q_a + q_b + q_{\text{laser}} + q_{\text{conv}} = Mc_p \frac{T_m^{p+1} - T_m^p}{\Delta t}$$

Continued ...



**PROBLEM 5.131 (Cont.)**

$$k(d \cdot 1) \frac{T_{m-1}^{p+1} - T_m^{p+1}}{\Delta x} + k(d \cdot 1) \frac{T_{m+1}^{p+1} - T_m^{p+1}}{\Delta x} + q_o''(\Delta x \cdot 1) + 2h(\Delta x \cdot 1)(T_\infty - T_m^{p+1}) = \rho(\Delta x \cdot d \cdot 1)c_p \frac{T_m^{p+1} - T_m^p}{\Delta t}$$

$$T_m^p = (1 + 2Fo + 2Fo \cdot Bi) T_m^{p+1} - Fo(T_{m+1}^{p+1} + T_{m-1}^{p+1}) - 2Fo \cdot Bi \cdot T_\infty - Fo \cdot Q \quad (1)$$

where

$$Fo = \frac{\alpha \Delta t}{\Delta x^2} = \frac{1.757 \times 10^{-5} \text{ m}^2 / \text{s} \times 1 \text{ s}}{(0.004 \text{ m})^2} = 1.098 \quad (2)$$

$$Bi = \frac{h(\Delta x^2 / d)}{k} = \frac{100 \text{ W/m}^2 \cdot \text{K} (0.004^2 / 0.00125) \text{ m}}{60 \text{ W/m} \cdot \text{K}} = 0.0213 \quad (3)$$

$$Q = \frac{q_o''(\Delta x^2 / d)}{k} = \frac{85,000 \text{ W/m}^2 (0.004^2 / 0.00125) \text{ m}}{60 \text{ W/m} \cdot \text{K}} = 18.133. \quad (4)$$

The results of the matrix inversion numerical method of solution ( $\Delta x = 4\text{mm}$ ,  $\Delta t = 1\text{s}$ ) are shown below. The temperature histories for the center ( $m = 1$ ) and film edge ( $m = 5$ ) nodes,  $T(0,t)$  and  $T(x_1,t)$ , respectively, permit determining whether the adhesive has cured ( $T \geq 90^\circ\text{C}$  for 10 s).

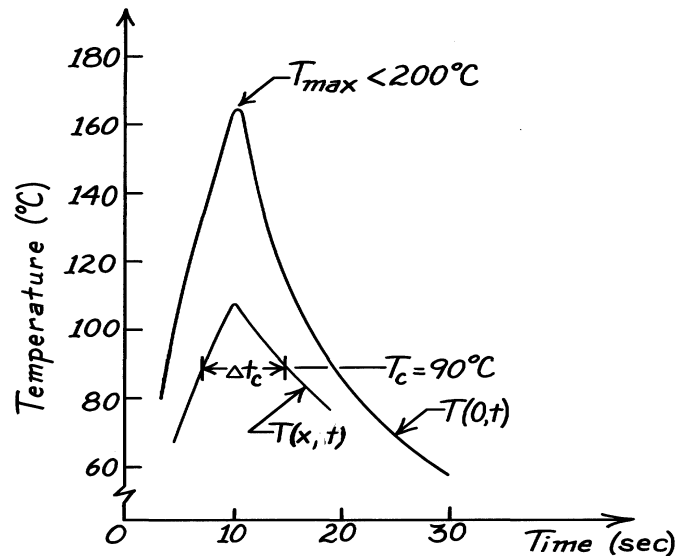

Certainly the center region,  $T(0,t)$ , is fully cured and furthermore, the degradation temperature ( $200^\circ\text{C}$ ) has not been exceeded. From the  $T(x_1,t)$  distribution, note that  $\Delta t_c \approx 8$  sec, which is 20% less than the 10 s interval sought. Hence, the laser exposure (now 10 s) should be slightly increased and quite likely, the maximum temperature will not exceed  $200^\circ\text{C}$ .

### PROBLEM 5.132

**KNOWN:** Insulated rod of prescribed length and diameter, with one end in a fixture at 200°C, reaches a uniform temperature. Suddenly the insulating sleeve is removed and the rod is subjected to a convection process.

**FIND:** (a) Time required for the mid-length of the rod to reach 100°C, (b) Temperature history  $T(x,t \leq t_1)$ , where  $t_1$  is time at which the midlength reaches 50°C. Temperature distribution at 0, 200s, 400s and  $t_1$ .

**SCHEMATIC:**

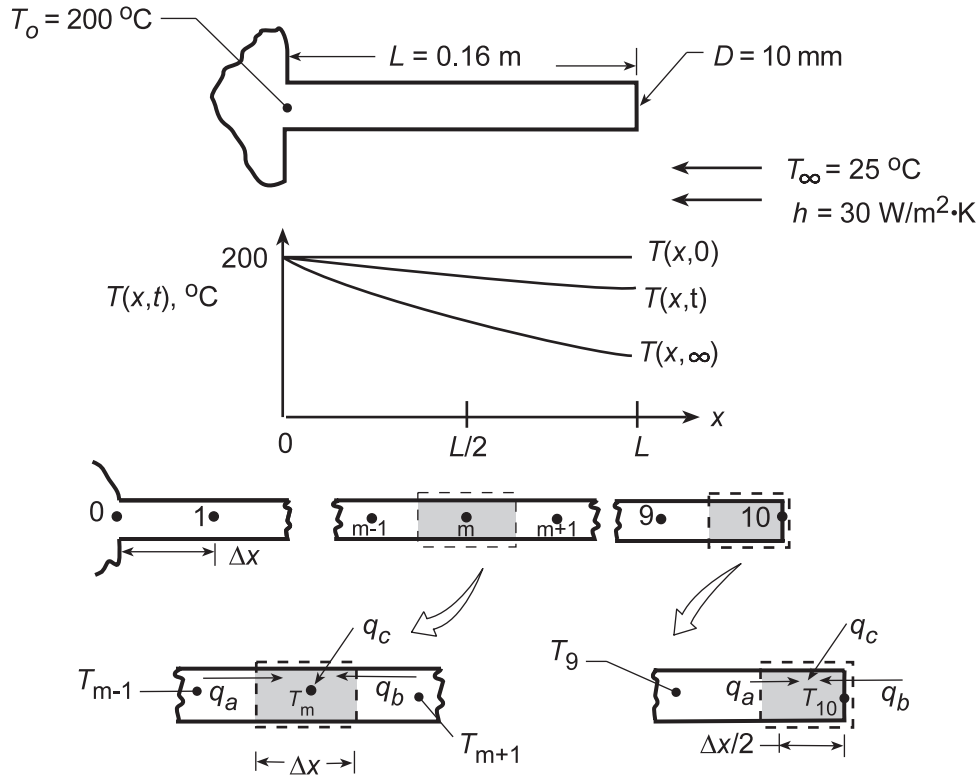

**ASSUMPTIONS:** (1) One-dimensional transient conduction in rod, (2) Uniform  $h$  along rod and at end, (3) Negligible radiation exchange between rod and surroundings, (4) Constant properties.

**ANALYSIS:** (a) Choosing  $\Delta x = 0.016 \text{ m}$ , the finite-difference equations for the interior and end nodes are obtained.

*Interior Point, m:*

$$q_a + q_b + q_c = \rho \cdot A_c \Delta x \cdot c_p \cdot \frac{T_m^{p+1} - T_m^p}{\Delta t}$$

$$k \cdot A_c \frac{T_{m-1}^p - T_m^p}{\Delta x} + k A_c \frac{T_{m+1}^p - T_m^p}{\Delta x} + h P \Delta x (T_\infty - T_m^p) = \rho A_c \Delta x c_p \frac{T_m^{p+1} - T_m^p}{\Delta t}$$

Regrouping,

$$T_m^{p+1} = T_m^p (1 - 2Fo - Bi \cdot Fo) + Fo (T_{m-1}^p + T_{m+1}^p) + Bi \cdot Fo T_\infty \quad (1)$$

where

$$Fo = \frac{\alpha \Delta t}{\Delta x^2} \quad (2)$$

$$Bi = h \left[ \frac{\Delta x^2}{(A_c/P)} \right] / k. \quad (3)$$

From Eq. (1), recognize that the stability of the numerical solution will be assured when the first term on the RHS is positive; that is

Continued...

**PROBLEM 5.132 (Cont.)**

$$(1 - 2Fo - Bi \cdot Fo) \geq 0 \quad \text{or} \quad Fo \leq 1/(2 + Bi). \quad (4)$$

*Nodal Point 1:* Consider Eq. (1) for the special case that  $T_{m-1}^P = T_o$ , which is independent of time.

Hence,

$$T_1^{P+1} = T_1^P (1 - 2Fo - Bi \cdot Fo) + Fo(T_o + T_2^P) + Bi \cdot Fo T_\infty. \quad (5)$$

*End Nodal Point 10:*  $q_a + q_b + q_c = \rho \cdot A_c \frac{\Delta x}{2} \cdot c_p \frac{T_{10}^{P+1} - T_{10}^P}{\Delta t}$

$$k \cdot A_c \frac{T_9^P - T_{10}^P}{\Delta x} + hA_c (T_\infty - T_{10}^P) + hP \frac{\Delta x}{2} (T_\infty - T_{10}^P) = \rho A_c \frac{\Delta x}{2} c_p \frac{T_{10}^{P+1} - T_{10}^P}{\Delta t}$$

Regrouping,  $T_{10}^{P+1} = T_{10}^P (1 - 2Fo - 2N \cdot Fo - Bi \cdot Fo) + 2FoT_9^P + T_\infty (2N \cdot Fo + Bi \cdot Fo)$  (6)

where  $N = h\Delta x/k$ . (7)

The stability criterion is  $Fo \leq 1/2(1 + N + Bi/2)$ . (8)

With the finite-difference equations established, we can now proceed with the numerical solution.

Having already specified  $\Delta x = 0.016$  m, Bi can now be evaluated. Noting that  $A_c = \pi D^2/4$  and  $P = \pi D$ , giving  $A_c/P = D/4$ , Eq. (3) yields

$$Bi = 30 \text{ W/m}^2 \cdot \text{K} \left[ \frac{(0.016 \text{ m})^2}{\frac{0.010 \text{ m}}{4}} \right] / 14.8 \text{ W/m} \cdot \text{K} = 0.208 \quad (9)$$

From the stability criteria, Eqs. (4) and (8), for the finite-difference equations, it is recognized that Eq. (8) requires the greater value of Fo. Hence

$$Fo = \frac{1}{2} \left( 1 + 0.0324 + \frac{0.208}{2} \right) = 0.440 \quad (10)$$

where from Eq. (7),  $N = \frac{30 \text{ W/m}^2 \cdot \text{K} \times 0.016 \text{ m}}{14.8 \text{ W/m} \cdot \text{K}} = 0.0324$ . (11)

From the definition of Fo, Eq. (2), we obtain the time increment

$$\Delta t = \frac{Fo(\Delta x)^2}{\alpha} = 0.440(0.016 \text{ m})^2 / 3.63 \times 10^{-6} \text{ m}^2/\text{s} = 31.1 \text{ s} \quad (12)$$

and the time relation is  $t = p\Delta t = 31.1t$ . (13)

Using the numerical values for Fo, Bi and N, the finite-difference equations can now be written (°C).

*Nodal Point m* ( $2 \leq m \leq 9$ ):

$$T_m^{P+1} = T_m^P (1 - 2 \times 0.440 - 0.208 \times 0.440) + 0.440(T_{m-1}^P + T_{m+1}^P) + 0.208 \times 0.440 \times 25$$

$$T_m^{P+1} = 0.029T_m^P + 0.440(T_{m-1}^P + T_{m+1}^P) + 2.3 \quad (14)$$

*Nodal Point 1:*

$$T_1^{P+1} = 0.029T_1^P + 0.440(200 + T_2^P) + 2.3 = 0.029T_1^P + 0.440T_2^P + 90.3 \quad (15)$$

*Nodal Point 10:*

$$T_{10}^{P+1} = 0 \times T_{10}^P + 2 \times 0.440T_9^P + 25(2 \times 0.0324 \times 0.440 + 0.208 \times 0.440) = 0.880T_9^P + 3.0 \quad (16)$$

Continued...

### PROBLEM 5.132 (Cont.)

Using finite-difference equations (14-16) with Eq. (13), the calculations may be performed to obtain

p	t(s)	T <sub>1</sub>	T <sub>2</sub>	T <sub>3</sub>	T <sub>4</sub>	T <sub>5</sub>	T <sub>6</sub>	T <sub>7</sub>	T <sub>8</sub>	T <sub>9</sub>	T <sub>10</sub> (°C)
0	0	200	200	200	200	200	200	200	200	200	200
1	31.1	184.1	181.8	181.8	181.8	181.8	181.8	181.8	181.8	181.8	179.0
2	62.2	175.6	166.3	165.3	165.3	165.3	165.3	165.3	165.3	164.0	163.0
3	93.3	168.6	154.8	150.7	150.7	150.7	150.7	150.7	149.7	149.2	147.3
4	124.4	163.3	145.0	138.8	137.0	137.0	137.0	136.5	136.3	135.0	134.3
5	155.5	158.8	137.1	128.1	125.3	124.5	124.3	124.2	123.4	123.0	121.8
6	186.6	155.2	130.2	119.2	114.8	113.4	113.0	112.6	112.3	111.5	111.2
7	217.7	152.1	124.5	111.3	105.7	103.5	102.9	102.4			
8	248.8	145.1	119.5	104.5	97.6	94.8					

Using linear interpolation between rows 7 and 8, we obtain  $T(L/2, 230s) = T_5 \approx 100^\circ\text{C}$ . <

(b) Using the option concerning *Finite-Difference Equations for One-Dimensional Transient Conduction in Extended Surfaces* from the IHT Toolpad, the desired temperature histories were computed for  $0 \leq t \leq t_1 = 930s$ . A *Lookup Table* involving data for  $T(x)$  at  $t = 0, 200, 400$  and  $930s$  was created.

t(s)/x(mm)	0	16	32	48	64	80	96	112	128	144	160
0	200	200	200	200	200	200	200	200	200	200	200
200	200	157.8	136.7	127.0	122.7	121.0	120.2	119.6	118.6	117.1	114.7
400	200	146.2	114.9	97.32	87.7	82.57	79.8	78.14	76.87	75.6	74.13
930	200	138.1	99.23	74.98	59.94	50.67	44.99	41.53	39.44	38.2	37.55

and the *LOOKUPVAL2* interpolating function was used with the *Explore* and *Graph* feature of IHT to create the desired plot.

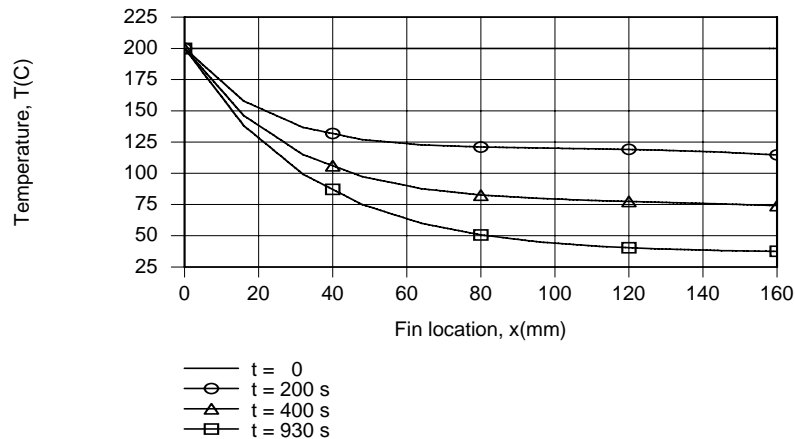

Temperatures decrease with increasing  $x$  and  $t$ , and except for early times ( $t < 200s$ ) and locations in proximity to the fin tip, the magnitude of the temperature gradient,  $|dT/dx|$ , decreases with increasing  $x$ . The slight increase in  $|dT/dx|$  observed for  $t = 200s$  and  $x \rightarrow 160$  mm is attributable to significant heat loss from the fin tip.

**COMMENTS:** The steady-state condition may be obtained by extending the finite-difference calculations in time to  $t \approx 2650s$  or from Eq. 3.75.

### PROBLEM 5.133

**KNOWN:** Tantalum rod initially at a uniform temperature, 300K, is suddenly subjected to a current flow of 80A; surroundings (vacuum enclosure) and electrodes maintained at 300K.

**FIND:** (a) Estimate time required for mid-length to reach 1000K, (b) Determine the steady-state temperature distribution and estimate how long it will take to reach steady-state. Use a finite-difference method with a space increment of 10mm.

**SCHEMATIC:**



**ASSUMPTIONS:** (1) One-dimensional, transient conduction in rod, (2) Surroundings are much larger than rod, (3) Properties are constant and evaluated at an average temperature.

**PROPERTIES:** Table A-1, Tantalum ( $\bar{T} = (300+1000)\text{K}/2 = 650\text{K}$ ):  $\rho = 16,600\text{ kg/m}^3$ ,  $c = 147\text{ J/kg}\cdot\text{K}$ ,  $k = 58.8\text{ W/m}\cdot\text{K}$ , and  $\alpha = k/\rho c = 58.8\text{ W/m}\cdot\text{K}/16,600\text{ kg/m}^3 \times 147\text{ J/kg}\cdot\text{K} = 2.410 \times 10^{-5}\text{ m}^2/\text{s}$ .

**ANALYSIS:** The finite-difference equation is

$$T_m^{p+1} = \text{Fo} \left( T_{m-1}^p + T_{m+1}^p \right) + (1 - 2\text{Fo}) T_m^p - \frac{\varepsilon P \sigma \Delta x^2}{k A_c} \text{Fo} \left( T_m^{4,p} - T_{\text{sur}}^4 \right) + \frac{I^2 \rho_e \Delta x^2}{k A_c^2} \cdot \text{Fo} \quad (1)$$

where  $\text{Fo} = \alpha \Delta t / \Delta x^2$        $A_c = \pi D^2 / 4$        $P = \pi D$ . (2,3,4)

From the stability criterion, let  $\text{Fo} = 1/2$  and numerically evaluate terms of Eq. (1).

$$T_m^{p+1} = \frac{1}{2} \left( T_{m-1}^p + T_{m+1}^p \right) - \frac{0.1 \times 5.67 \times 10^{-8}\text{ W/m}^2 \cdot \text{K}^4 \times (0.01\text{m})^2 \cdot 4}{58.8\text{ W/m} \cdot \text{K} \times (0.003\text{m})} \cdot \frac{1}{2} \left( T_m^{4,p} - [300\text{K}]^4 \right) + \frac{(80\text{A})^2 \times 95 \times 10^{-8}\text{ Ohm} \cdot \text{m} \times (0.01\text{m})^2}{58.8\text{ W/m} \cdot \text{K} \left( \pi [0.003\text{m}]^2 / 4 \right)^2} \cdot \frac{1}{2}$$

$$T_m^{p+1} = \frac{1}{2} \left( T_{m-1}^p + T_{m+1}^p \right) - 6.4285 \times 10^{-12} T_m^{4,p} + 103.53. \quad (5)$$

Note that this form applies to nodes 0 through 5. For node 0,  $T_{m-1} = T_{m+1} = T_1$ . Since  $\text{Fo} = 1/2$ , using Eq. (2), find that

$$\Delta t = \Delta x^2 \text{Fo} / \alpha = (0.01\text{m})^2 \times 1/2 / 2.410 \times 10^{-5}\text{ m}^2/\text{s} = 2.07\text{s}. \quad (6)$$

Hence,  $t = p \Delta t = 2.07p$ . (7)

Continued ...

**PROBLEM 5.133 (Cont.)**

(a) To estimate the time required for the mid-length to reach 1000K, that is  $T_0 = 1000\text{K}$ , perform the forward-marching solution beginning with  $T_i = 300\text{K}$  at  $p = 0$ . The solution, as tabulated below, utilizes Eq. (5) for successive values of  $p$ . Elapsed time is determined by Eq. (7).

P	t(s)	$T_0$	$T_1$	$T_2$	$T_3$	$T_4$	$T_5$	$T_6(^{\circ}\text{C})$
0	0	300	300	300	300	300	300	300
1		403.5	403.5	403.5	403.5	403.5	403.5	300
2		506.9	506.9	506.9	506.9	506.9	455.1	300
3		610.0	610.0	610.0	610.0	584.1	506.7	300
4		712.6	712.6	712.6	699.7	661.1	545.2	300
5	10.4	814.5	814.5	808.0	788.8	724.7	583.5	300
6		915.2	911.9	902.4	867.4	787.9	615.1	300
7		1010.9	1007.9	988.9	945.0	842.3	646.6	300
8		1104.7	1096.8	1073.8	1014.0	896.1	673.6	300
9		1190.9	1183.5	1150.4	1081.7	943.2	700.3	300
10	20.7	1274.1	1261.6	1224.9	1141.5	989.4	723.6	300
11		1348.2	1336.7	1290.6	1199.8	1029.9	746.5	300
12		1419.7	1402.4	1353.9	1250.5	1069.4	766.5	300
13		1479.8	1465.5	1408.4	1299.8	1103.6	786.0	300
14		1542.6	1538.2	1460.9	1341.2	1136.9	802.9	300
15	31.1	1605.3	1569.3	1514.0	1381.6	1164.8	819.3	300

Note that, at  $p \approx 6.9$  or  $t = 6.9 \times 2.07 = 14.3\text{s}$ , the mid-point temperature is  $T_0 \approx 1000\text{K}$ . <

(b) The steady-state temperature distribution can be obtained by continuing the marching solution until only small changes in  $T_m$  are noted. From the table above, note that at  $p = 15$  or  $t = 31\text{s}$ , the temperature distribution is still changing with time. It is likely that at least 15 more calculation sets are required to see whether steady-state is being approached.

**COMMENTS:** (1) This problem should be solved with a computer rather than a hand-calculator. For such a situation, it would be appropriate to decrease the spatial increment in order to obtain better estimates of the temperature distribution.

(2) If the rod were very long, the steady-state temperature distribution would be very flat at the mid-length  $x = 0$ . Performing an energy balance on the small control volume shown to the right, find

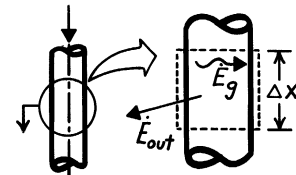

$$\dot{E}_g - \dot{E}_{out} = 0$$

$$I^2 \frac{\rho_e \Delta x}{A_c} - \epsilon \sigma P \Delta x (T_0^4 - T_{sur}^4) = 0.$$

Substituting numerical values, find  $T_0 = 2003\text{K}$ . It is unlikely that the present rod would ever reach this steady-state, maximum temperature. That is, the effect of conduction along the rod will cause the center temperature to be less than this value.

### PROBLEM 5.134

**KNOWN:** Support rod spanning a channel whose walls are maintained at  $T_b = 300$  K. Suddenly the rod is exposed to cross flow of hot gases with  $T_\infty = 600$  K and  $h = 75$  W/m<sup>2</sup>·K. After the rod reaches steady-state conditions, the hot gas flow is terminated and the rod cools by free convection and radiation exchange with surroundings.

**FIND:** (a) Compute and plot the midspan temperature as a function of elapsed heating time; compare the steady-state temperature distribution with results from an analytical model of the rod and (b) Compute the midspan temperature as a function of elapsed cooling time and determine the time required for the rod to reach the safe-to-touch temperature of 315 K.

**SCHEMATIC:**

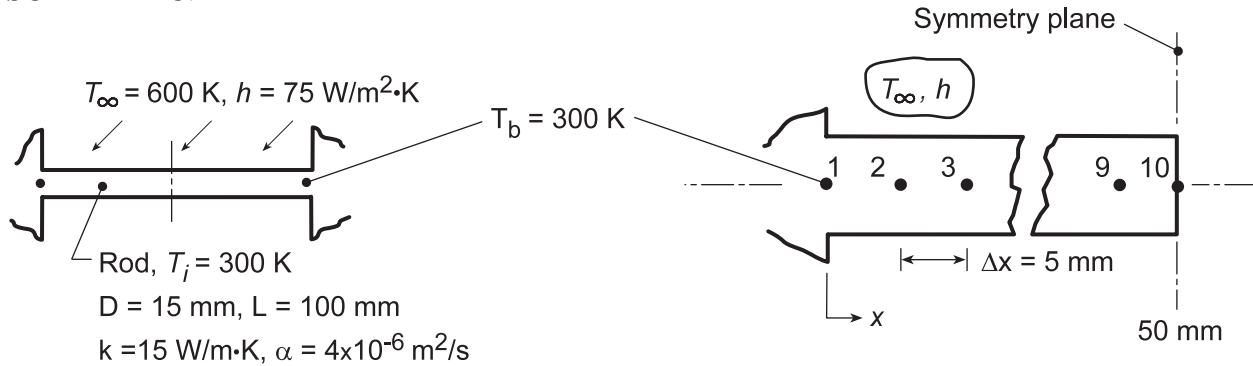

**ASSUMPTIONS:** (1) One-dimensional, transient conduction in rod, (2) Constant properties, (3) During heating process, uniform convection coefficient over rod, (4) During cooling process, free convection coefficient is of the form  $h = C\Delta T^n$  where  $C = 4.4$  W/m<sup>2</sup>·K<sup>1.188</sup> and  $n = 0.188$ , and (5) During cooling process, surroundings are large with respect to the rod.

**ANALYSIS:** (a) The finite-difference equations for the 10-node mesh shown above can be obtained using the *IHT Finite-Difference Equation, One-Dimensional, Transient Extended Surfaces Tool*. The temperature-time history for the midspan position  $T_{10}$  is shown in the plot below. The steady-state temperature distribution for the rod can be determined from Eq. 3.80, Case B, Table 3.4. This case is treated in the *IHT Extended Surfaces Model, Temperature Distribution and Heat Rate, Rectangular Pin Fin*, for the adiabatic tip condition. The following table compares the steady-state temperature distributions for the numerical and analytical methods.

Method	Temperatures (K) vs. Position $x$ (mm)					
	0	10	20	30	40	50
Analytical	300	386.1	443.4	479.5	499.4	505.8
Numerical	300	386.0	443.2	479.3	499.2	505.6

The comparison is excellent indicating that the nodal mesh is sufficiently fine to obtain precise results.

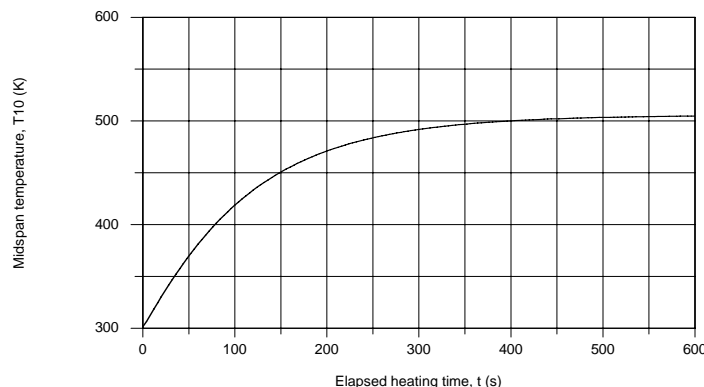

Continued...

### PROBLEM 5.134 (Cont.)

(b) The same finite-difference approach can be used to model the cooling process. In using the IHT tool, the following procedure was used: (1) Set up the FDEs with the convection coefficient expressed as  $h_m = h_{fc,m} + h_{r,m}$ , the sum of the free convection and linearized radiation coefficients based upon nodal temperature  $T_m$ .

$$h_{fc,m} = C(T_m^p - T_\infty)$$

$$h_{r,m} = \varepsilon\sigma(T_m^p + T_{sur})\left(\left(T_m^p\right)^2 + T_{sur}^2\right)$$

(2) For the initial solve, set  $h_{fc,m} = h_{r,m} = 5 \text{ W/m}^2\cdot\text{K}$  and solve, (3) Using the solved results as the Initial Guesses for the next solve, allow  $h_{fc,m}$  and  $h_{r,m}$  to be unknowns. The temperature-time history for the midspan during the cooling process is shown in the plot below. The time to reach the safe-to-touch temperature,  $T_{10}^p = 315 \text{ K}$ , is

$$t = 550 \text{ s}$$

<

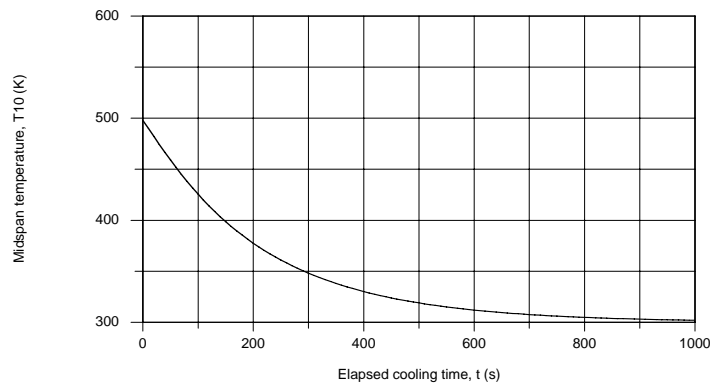



### PROBLEM 5.135

**KNOWN:** Thin metallic foil of thickness,  $w$ , whose edges are thermally coupled to a sink at temperature,  $T_{\text{sink}}$ , initially at a uniform temperature  $T_i = T_{\text{sink}}$ , is suddenly exposed on the top surface to an ion beam heat flux,  $q_s''$ , and experiences radiation exchange with the vacuum enclosure walls at  $T_{\text{sur}}$ . Consider also the situation when the foil is operating under steady-state conditions when suddenly the ion beam is deactivated.

**FIND:** (a) Compute and plot the midspan temperature-time history during the *heating* process; determine the elapsed time that this point on the foil reaches a temperature within 1 K of the steady-state value, and (b) Compute and plot the midspan temperature-time history during the *cooling* process from steady-state operation; determine the elapsed time that this point on the foil reaches the *safe-to-touch* temperature of 315 K.

**SCHEMATIC:**

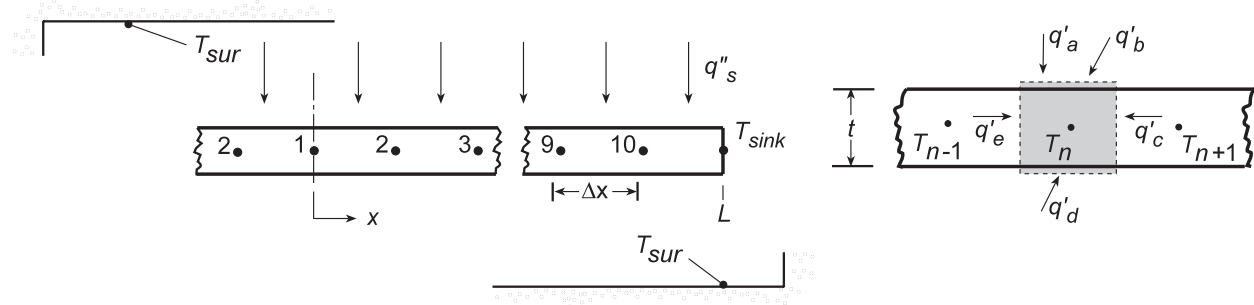

**ASSUMPTIONS:** (1) One-dimensional, transient conduction in the foil, (2) Constant properties, (3) Upper and lower surfaces of foil experience radiation exchange with the large surroundings, (4) Ion beam incident on upper surface only, (4) Foil is of unit width normal to the page.

**ANALYSIS:** (a) The finite-difference equations for the 10-node mesh shown above can be obtained using the *IHT Finite-Difference Equation, One-Dimensional, Transient, Extended Surfaces Tool*. In formulating the energy-balance functions, the following steps were taken: (1) the FDE function coefficient  $h$  must be identified for each node, e.g.,  $h_1$  and (2) coefficient can be represented by the linearized radiation coefficient, e.g.,  $h_1 = \epsilon\sigma(T_1 + T_{\text{sur}})(T_1^2 + T_{\text{sur}}^2)$ , (3) set  $q_a'' = q_s''/2$  since the ion beam is incident on only the top surface of the foil, and (4) when solving, the initial condition corresponds to  $T_i = 300$  K for each node. The temperature-time history of the midspan position is shown below. The time to reach within 1 K of the steady-state temperature (374.1 K) is

$$T_{10}(t_h) = 373 \text{ K} \quad t_h = 136 \text{ s} \quad \leftarrow$$

(b) The same IHT workspace may be used to obtain the temperature-time history for the cooling process by taking these steps: (1) set  $q_s'' = 0$ , (2) specify the initial conditions as the steady-state temperature (K) distribution tabulated below,

$T_1$	$T_2$	$T_3$	$T_4$	$T_5$	$T_6$	$T_7$	$T_8$	$T_9$	$T_{10}$
374.1	374.0	373.5	372.5	370.9	368.2	363.7	356.6	345.3	327.4

(3) when performing the integration of the independent time variable, set the start value as 200 s and (4) save the results for the heating process in Data Set A. The temperature-time history for the heating and cooling processes can be made using Data Browser results from the Working and A Data Sets. The time required for the midspan to reach the *safe-to-touch* temperature is

$$T_{10}(t_c) = 315 \text{ K} \quad t_c = 73 \text{ s} \quad \leftarrow$$

Continued...

## PROBLEM 5.135 (Cont.)

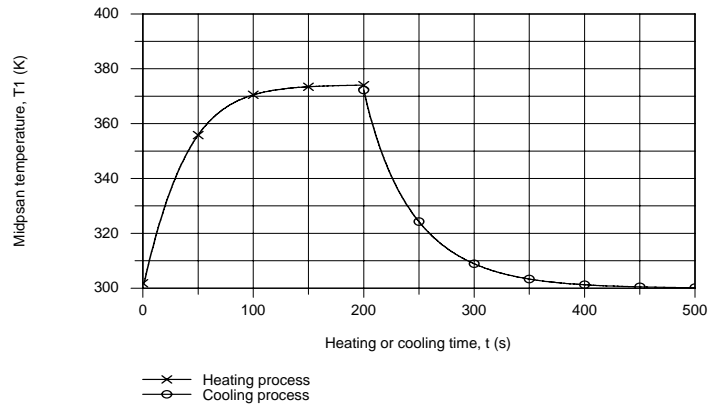

**COMMENTS:** The IHT workspace using the Finite-Difference Equations Tool to determine the temperature-time distributions is shown below. Some of the lines of code were omitted to save space on the page.

### // Finite Difference Equations Tool: One-Dimensional, Transient, Extended Surface

/\* Node 1: extended surface interior node; transient conditions; e and w labeled 2 and 2. \*/

$\rho * cp * \text{der}(T1,t) = \text{fd\_1d\_xsur\_i}(T1,T2,T2,k,\text{qdot},Ac,P,\text{deltax},Tinf, h1,q''a)$

$q''a1 = q''s / 2$  // Applied heat flux, W/m<sup>2</sup>; on the upper surface only

$h1 = \text{eps} * \text{sigma} * (T1 + Tsur) * (T1^2 + Tsur^2)$

$\text{sigma} = 5.67\text{e-}8$  // Boltzmann constant, W/m<sup>2</sup>.K<sup>4</sup>

/\* Node 2: extended surface interior node; transient conditions; e and w labeled 3 and 1. \*/

$\rho * cp * \text{der}(T2,t) = \text{fd\_1d\_xsur\_i}(T2,T3,T3,T1,k,\text{qdot},Ac,P,\text{deltax},Tinf, h2,q''a2)$

$q''a2 = 0$  // Applied heat flux, W/m<sup>2</sup>; zero flux shown

$h2 = \text{eps} * \text{sigma} * (T2 + Tsur) * (T2^2 + Tsur^2)$

.....

.....

/\* Node 10: extended surface interior node; transient conditions; e and w labeled sk and 9. \*/

$\rho * cp * \text{der}(T10,t) = \text{fd\_1d\_xsur\_i}(T10,Tsk,T9,T9,k,\text{qdot},Ac,P,\text{deltax},Tinf, h10,q''a)$

$q''a10 = 0$  // Applied heat flux, W/m<sup>2</sup>; zero flux shown

$h10 = \text{eps} * \text{sigma} * (T10 + Tsur) * (T10^2 + Tsur^2)$

### // Assigned variables

$\text{deltax} = L / 10$  // Spatial increment, m

$Ac = w * 1$  // Cross-sectional area, m<sup>2</sup>

$P = 2 * 1$  // Perimeter, m

$L = 0.150$  // Overall length, m

$w = 0.00025$  // Foil thickness, m

$\text{eps} = 0.45$  // Foil emissivity

$Tinf = Tsur$  // Fluid temperature, K

$Tsur = 300$  // Surroundings temperature, K

$k = 40$  // Foil thermal conductivity

$Tsk = 300$  // Sink temperature, K

$q''s = 600$  // Ion beam heat flux, W/m<sup>2</sup>; for heating process

$q''s = 0$  // Ion beam heat flux, W/m<sup>2</sup>; for cooling process

$\text{qdot} = 0$  // Foil volumetric generation rate, W/m<sup>3</sup>

$\alpha = 3\text{e-}5$  // Thermal diffusivity, m<sup>2</sup>/s

$\rho = 1000$  // Density, kg.m<sup>3</sup>; arbitrary value

$\alpha = k / (\rho * cp)$  // Definition

### PROBLEM 5.136

**KNOWN:** Stack or book of steel plates (sp) and circuit boards (b) subjected to a prescribed platen heating schedule  $T_p(t)$ . See Problem 5.46 for other details of the book.

**FIND:** (a) Using the implicit numerical method with  $\Delta x = 2.36\text{mm}$  and  $\Delta t = 60\text{s}$ , find the mid-plane temperature  $T(0,t)$  of the book and determine whether curing will occur ( $> 170^\circ\text{C}$  for 5 minutes), (b) Determine how long it will take  $T(0,t)$  to reach  $37^\circ\text{C}$  following reduction of the platen temperature to  $15^\circ\text{C}$  (at  $t = 50$  minutes), (c) Validate code by using a sudden change of platen temperature from  $15$  to  $190^\circ\text{C}$  and compare with the solution of Problem 5.38.

**SCHEMATIC:**

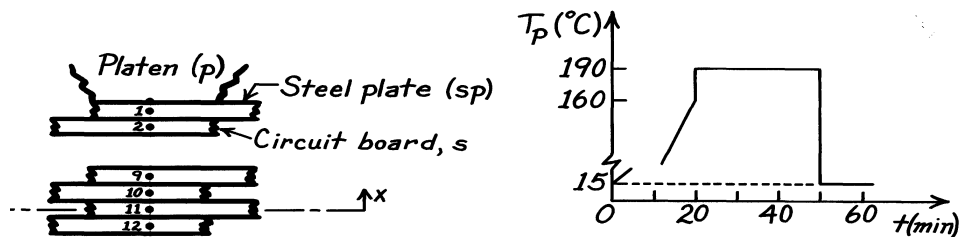

**ASSUMPTIONS:** (1) One-dimensional conduction, (2) Negligible contact resistance between plates, boards and platens.

**PROPERTIES:** Steel plates (sp, given):  $\rho_{sp} = 8000 \text{ kg/m}^3$ ,  $c_{p,sp} = 480 \text{ J/kg}\cdot\text{K}$ ,  $k_{sp} = 12 \text{ W/m}\cdot\text{K}$ ; Circuit boards (b, given):  $\rho_b = 1000 \text{ kg/m}^3$ ,  $c_{p,b} = 1500 \text{ J/kg}\cdot\text{K}$ ,  $k_b = 0.30 \text{ W/m}\cdot\text{K}$ .

**ANALYSIS:** (a) Using the suggested space increment  $\Delta x = 2.36\text{mm}$ , the model grid spacing treating the steel plates (sp) and circuit boards (b) as discrete elements, we need to derive the nodal equations for the interior nodes (2-11) and the node next to the platen (1). Begin by defining appropriate control volumes and apply the conservation of energy requirement.

*Effective thermal conductivity,  $k_e$ :* Consider an adjacent steel plate-board arrangement. The thermal resistance between the nodes  $i$  and  $j$  is

$$R_{ij}'' = \frac{\Delta x}{k_e} = \frac{\Delta x/2}{k_b} + \frac{\Delta x/2}{k_{sp}}$$

$$k_e = \frac{2}{1/k_b + 1/k_{sp}} = \frac{2}{1/0.3 + 1/12} \text{ W/m}\cdot\text{K}$$

$$k_e = 0.585 \text{ W/m}\cdot\text{K}$$

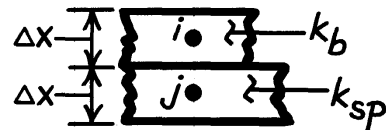

*Odd-numbered nodes,  $3 \leq m \leq 11$  - steel plates (sp):* Treat as interior nodes using Eq. 5.97 with

$$\alpha_{sp} = \frac{k_e}{\rho_{sp} c_{sp}} = \frac{0.585 \text{ W/m}\cdot\text{K}}{8000 \text{ kg/m}^3 \times 480 \text{ J/kg}\cdot\text{K}} = 1.523 \times 10^{-7} \text{ m}^2/\text{s}$$

$$Fo_m = \frac{\alpha_{sp} \Delta t}{\Delta x^2} = \frac{1.523 \times 10^{-7} \text{ m}^2/\text{s} \times 60\text{s}}{(0.00236 \text{ m})^2} = 1.641$$

Continued ...

**PROBLEM 5.136 (Cont.)**

to obtain, with  $m$  as odd-numbered,

$$(1 + 2Fo_m)T_m^{p+1} - Fo_m(T_{m-1}^{p+1} + T_{m+1}^{p+1}) = T_m^p \quad (1)$$

*Even-numbered nodes,  $2 \leq n \leq 10$  - circuit boards (b):* Using Eq. 5.97 and evaluating  $\alpha_b$  and  $Fo_n$

$$\alpha_b = \frac{k_e}{\rho_b c_b} = 3.900 \times 10^{-7} \text{ m}^2/\text{s} \quad Fo_n = 4.201$$

$$(1 + 2Fo_n)T_n^{p+1} - Fo_n(T_{n-1}^{p+1} + T_{n+1}^{p+1}) = T_n^p \quad (2)$$

*Plate next to platen,  $n = 1$  - steel plate (sp):* The finite-difference equation for the plate node ( $n = 1$ ) next to the platen follows from a control volume analysis.

$$\dot{E}_{in} - \dot{E}_{out} = \dot{E}_{st}$$

$$q_a'' + q_b'' = \rho_{sp} \Delta x c_{sp} \frac{T_1^{p+1} - T_1^p}{\Delta t}$$

where

$$q_a'' = k_{sp} \frac{T_p(t) - T_1^{p+1}}{\Delta x/2} \quad q_b'' = k_e \frac{T_2^{p+1} - T_1^{p+1}}{\Delta x}$$

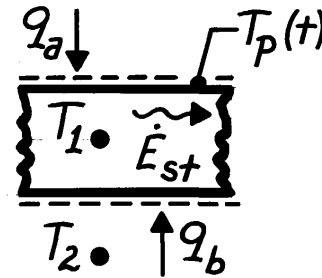

and  $T_p(t) = T_p(p)$  is the platen temperature which is

changed with time according to the heating schedule. Regrouping find,

$$\left( 1 + Fo_m \left( 1 + \frac{2k_{sp}}{k_e} \right) \right) T_1^{p+1} - Fo_m T_2^{p+1} - \frac{2k_{sp}}{k_e} Fo_m T_p(p) = T_1^p \quad (3)$$

where  $2k_{sp}/k_e = 2 \times 12 \text{ W/m}\cdot\text{K} / 0.585 \text{ W/m}\cdot\text{K} = 41.03$ .

Using the nodal Eqs. (1)-(3), an inversion method of solution was effected and the temperature distributions are shown on the following page.

*Temperature distributions - discussion:* As expected, the temperatures of the nodes near the center of the book considerably lag those nearer the platen. The criterion for cure is  $T \geq 170^\circ\text{C} = 443 \text{ K}$  for  $\Delta t_c = 5 \text{ min} = 300 \text{ sec}$ . From the temperature distributions, note that node 10 just reaches 443 K after 50 minutes and will not be cured. It appears that the region about node 5 will be cured.

(b) The time required for the book to reach  $37^\circ\text{C} = 310 \text{ K}$  can likewise be seen from the temperature distribution results. The plates/boards nearest the platen will cool to the safe handling temperature with  $1000 \text{ s} = 16 \text{ min}$ , but those near the center of the stack will require in excess of  $2000 \text{ s} = 32 \text{ min}$ .

Continued ...

**PROBLEM 5.136 (Cont.)**

(c) It is important when validating computer codes to have the program work a “problem” which has an exact analytical solution. You should select the problem such that all features of the code are tested.

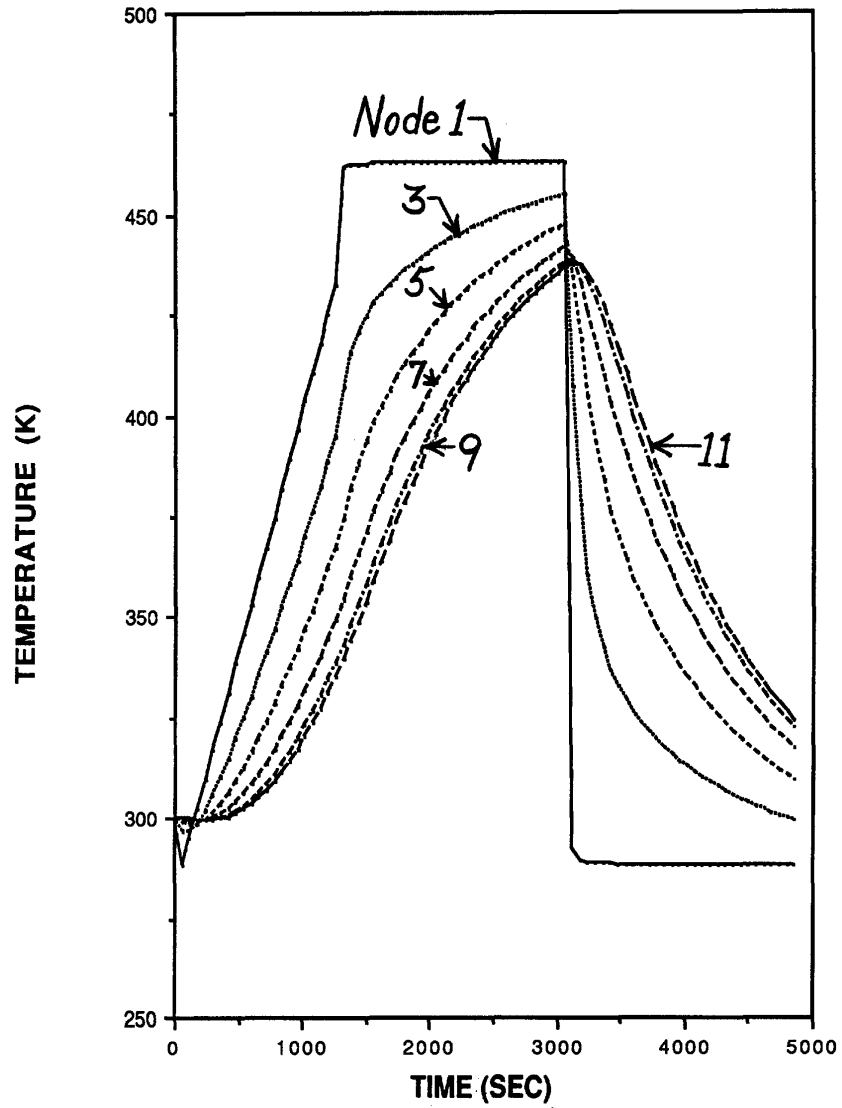

### PROBLEM 5.137

**KNOWN:** Thin, circular-disc subjected to induction heating causing a uniform heat generation in a prescribed region; upper surface exposed to convection process.

**FIND:** (a) Transient finite-difference equation for a node in the region subjected to induction heating, (b) Sketch the steady-state temperature distribution on T-r coordinates; identify important features.

**SCHEMATIC:**

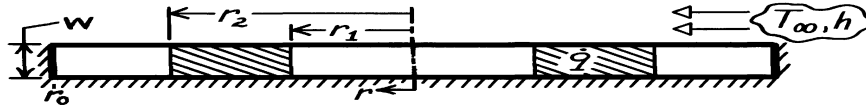

**ASSUMPTIONS:** (1) Thickness  $w \ll r_0$ , such that conduction is one-dimensional in r-direction, (2) In prescribed region,  $\dot{q}$  is uniform, (3) Bottom surface of disc is insulated, (4) Constant properties.

**ANALYSIS:** (a) Consider the nodal point arrangement for the region subjected to induction heating. The size of the control volume is  $V = 2\pi r_m \cdot \Delta r \cdot w$ . The energy conservation requirement for the node m has the form

$$\dot{E}_{in} - \dot{E}_{out} + \dot{E}_g = \dot{E}_{st}$$

with  $q_a + q_b + q_{conv} + \dot{q}V = \dot{E}_{st}$ .

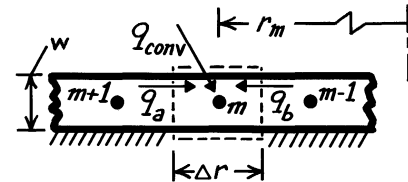

Recognizing that  $q_a$  and  $q_b$  are conduction terms and  $q_{conv}$  is the convection process,

$$k \left[ 2\pi \left[ r_m - \frac{\Delta r}{2} \right] w \right] \frac{T_{m-1}^p - T_m^p}{\Delta r} + k \left[ 2\pi \left[ r_m + \frac{\Delta r}{2} \right] w \right] \frac{T_{m+1}^p - T_m^p}{\Delta r} + h [2\pi r_m \cdot \Delta r] (T_\infty - T_m^p) + \dot{q} [2\pi r_m \cdot \Delta r \cdot w] = \rho c_p [2\pi r_m \cdot \Delta r \cdot w] \frac{T_m^{p+1} - T_m^p}{\Delta t}$$

Upon regrouping, the finite-difference equation has the form,

$$T_m^{p+1} = Fo \left[ \left[ 1 - \frac{\Delta r}{2r_m} \right] T_{m-1}^p + \left[ 1 + \frac{\Delta r}{2r_m} \right] T_{m+1}^p + Bi \left[ \frac{\Delta r}{w} \right] T_\infty + \frac{\dot{q}\Delta r^2}{k} \right] + \left[ 1 - 2Fo - Bi \cdot Fo \left[ \frac{\Delta r}{w} \right] \right] T_m^p \quad <$$

where  $Fo = \alpha\Delta t/\Delta r^2$        $Bi = h\Delta r/k$ .

(b) The steady-state temperature distribution has these features:

1. Zero gradient at  $r = 0, r_0$
2. No discontinuity at  $r_1, r_2$
3.  $T_{max}$  occurs in region  $r_1 < r < r_2$

Note also, distribution will not be linear anywhere; distribution is not parabolic in  $r_1 < r < r_2$  region.

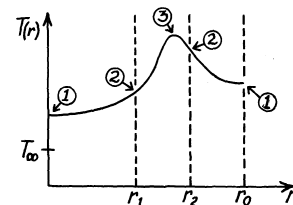

### PROBLEM 5.138

**KNOWN:** An electrical cable experiencing uniform volumetric generation; the lower half is well insulated while the upper half experiences convection.

**FIND:** (a) Explicit, finite-difference equations for an interior node  $(m,n)$ , the center node  $(0,0)$ , and an outer surface node  $(M,n)$  for the convective and insulated boundaries, and (b) Stability criterion for each FDE; identify the most restrictive criterion.

**SCHEMATIC:**

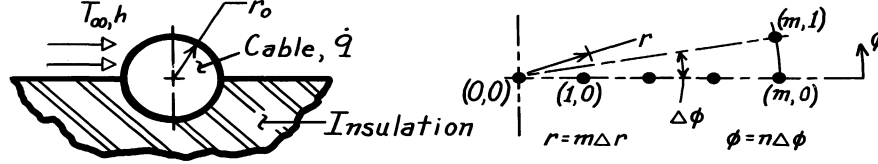

**ASSUMPTIONS:** (1) Two-dimensional  $(r,\phi)$ , transient conduction, (2) Constant properties, (3) Uniform  $\dot{q}$ .

**ANALYSIS:** The explicit, finite-difference equations may be obtained by applying energy balances to appropriate control volumes about the node of interest. Note the coordinate system defined above where  $(r,\phi) \rightarrow (m\Delta r, n\Delta\phi)$ . The stability criterion is determined from the coefficient associated with the node of interest.

*Interior Node  $(m,n)$ .* The control volume for an interior node is

$$V = r_m \Delta\phi \cdot \Delta r \cdot \ell$$

(with  $r_m = m\Delta r$ ,  $\ell = 1$ ) where  $\ell$  is the length normal to the page. The conservation of energy requirement is

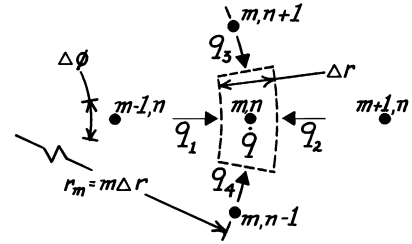
$$\dot{E}_{in} - \dot{E}_{out} + \dot{E}_g = \dot{E}_{st}$$

$$(q_1 + q_2)_r + (q_3 + q_4)_\theta + \dot{q}V = \rho cV \frac{T_{m,n}^{p+1} - T_{m,n}^p}{\Delta t}$$

$$k \cdot \left[ m - \frac{1}{2} \right] \Delta r \cdot \Delta\phi \cdot \frac{T_{m-1,n}^p - T_{m,n}^p}{\Delta r} + k \cdot \left[ m + \frac{1}{2} \right] \Delta r \cdot \Delta\phi \cdot \frac{T_{m+1,n}^p - T_{m,n}^p}{\Delta r} + k \cdot \Delta r \cdot \frac{T_{m,n+1}^p - T_{m,n}^p}{(m\Delta r)\Delta\phi}$$

$$+ k \cdot \Delta r \cdot \frac{T_{m,n-1}^p - T_{m,n}^p}{(m\Delta r)\Delta\phi} + \dot{q}(m\Delta r \cdot \Delta\phi) \cdot \Delta r = \rho c(m\Delta r \cdot \Delta\phi) \cdot \Delta r \cdot \frac{T_{m,n}^{p+1} - T_{m,n}^p}{\Delta t} \quad (1)$$

Define the Fourier number as

$$Fo = \frac{k}{\rho c} \cdot \frac{\Delta t}{\Delta r^2} = \frac{\alpha \Delta t}{\Delta r^2} \quad (2)$$

and then regroup the terms of Eq. (1) to obtain the FDE,

$$T_{m,n}^{p+1} = Fo \left\{ \frac{m-1/2}{m} T_{m-1,n}^p + \frac{m+1/2}{m} T_{m+1,n}^p + \frac{1}{(m\Delta\phi)^2} (T_{m,n+1}^p + T_{m,n-1}^p) + \frac{\dot{q}}{k} \Delta r^2 \right\}$$

$$+ \left\{ -Fo \left[ 2 + \frac{2}{(m\Delta\phi)^2} \right] + 1 \right\} T_{m,n}^p. \quad (3) <$$

Continued ...

**PROBLEM 5.138 (Cont.)**

The stability criterion requires that the last term on the right-hand side in braces be positive. That is, the coefficient of  $T_{m,n}^p$  must be positive and the stability criterion is

$$Fo \leq 1/2 \left[ 1 + 1/(m\Delta\phi)^2 \right] \quad (4)$$

Note that, for  $m \gg 1/2$  and  $(m\Delta\phi)^2 \gg 1$ , the FDE takes the form of a 1-D cartesian system. *Center Node (0,0)*. For the control volume,

$V = \pi (\Delta r/2)^2 \cdot 1$ . The energy balance is

$\dot{E}'_{in} - \dot{E}'_{out} + \dot{E}'_g = \dot{E}'_{st}$  where  $\dot{E}'_{in} = \sum q'_n$ .

$$\begin{aligned} \sum_{n=0}^N k \cdot \left[ \frac{\Delta r}{2} \Delta\phi \right] \cdot \frac{T_{1,n}^p - T_o^p}{\Delta r} + \dot{q} \pi \left[ \frac{\Delta r}{2} \right]^2 \\ = \rho c \cdot \pi \left[ \frac{\Delta r}{2} \right]^2 \frac{T_o^{p+1} - T_o^p}{\Delta t} \end{aligned} \quad (5)$$

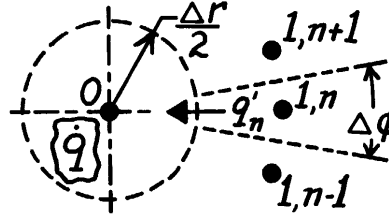

where  $N = (2\pi/\Delta\phi) - 1$ , the total number of  $q_n$ . Using the definition of  $Fo$ , find

$$T_o^{p+1} = 4Fo \left\{ \frac{1}{N+1} \sum_{n=0}^N T_{1,n}^p + \frac{\dot{q}}{4k} \Delta r^2 \right\} + (1 - 4Fo) T_o^p < \quad (7)$$

By inspection, the stability criterion is  $Fo \leq 1/4$ .

*Surface Nodes (M,n)*. The control volume

for the surface node is  $V = (M - 1/4)\Delta r \Delta\phi \cdot \Delta r/2 \cdot 1$ .

From the energy balance,

$\dot{E}'_{in} - \dot{E}'_{out} + \dot{E}'_g = (q'_1 + q'_2)_r + (q'_3 + q'_4)_\phi + \dot{q}V = \dot{E}'_{st}$

$$\begin{aligned} k \cdot (M - 1/2) \Delta r \cdot \Delta\phi \frac{T_{M-1,n}^p - T_{M,n}^p}{\Delta r} + h (M\Delta r \cdot \Delta\phi) (T_\infty - T_{M,n}^p) + k \cdot \frac{\Delta r}{2} \cdot \frac{T_{M,n+1}^p - T_{M,n}^p}{(M\Delta r) \Delta\phi} \\ + k \cdot \frac{\Delta r}{2} \cdot \frac{T_{M,n-1}^p - T_{M,n}^p}{(M\Delta r) \Delta\phi} + \dot{q} \left[ (M - 1/4) \Delta r \cdot \Delta\phi \cdot \frac{\Delta r}{2} \right] = \rho c \left[ (M - 1/4) \Delta r \cdot \Delta\phi \cdot \frac{\Delta r}{2} \right] \frac{T_{M,n}^{p+1} - T_{M,n}^p}{\Delta t} \end{aligned}$$

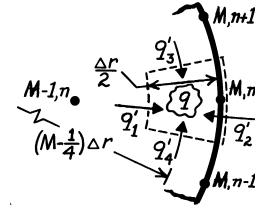

Regrouping and using the definitions for  $Fo = \alpha\Delta t/\Delta r^2$  and  $Bi = h\Delta r/k$ ,

$$\begin{aligned} T_{m,n}^{p+1} = Fo \left\{ 2 \frac{M-1/2}{M-1/4} T_{M-1,n}^p + \frac{1}{(M-1/4)M(\Delta\phi)^2} (T_{M,n+1}^p - T_{M,n-1}^p) + 2Bi \cdot T_\infty + \frac{\dot{q}}{k} \Delta r^2 \right\} \\ + \left\{ 1 - 2Fo \left[ \frac{M-1/2}{M-1/4} + Bi \cdot \frac{M}{M-1/4} + \frac{1}{(M-1/4)M(\Delta\phi)^2} \right] \right\} T_{M,n}^p \quad (8) < \end{aligned}$$

The stability criterion is 
$$Fo \leq \frac{1}{2 \left[ \frac{M-1/2}{M-1/4} + Bi \frac{M}{M-1/4} + \frac{1}{(M-1/4)M(\Delta\phi)^2} \right]} \quad (9)$$

To determine which stability criterion is most restrictive, compare Eqs. (4), (7) and (9). The most restrictive (lowest  $Fo$ ) has the largest denominator. For small values of  $m$ , it is not evident whether Eq. (7) is more restrictive than Eq. (4); Eq. (4) depends upon magnitude of  $\Delta\phi$ . Likewise, it is not clear whether Eq. (9) will be more or less restrictive than Eq. (7). Numerical values must be substituted.



### PROBLEM 5.139

**KNOWN:** Initial temperature distribution in two bars that are to be soldered together; interface contact resistance.

**FIND:** (a) Explicit FDE for  $T_{4,2}$  in terms of  $Fo$  and  $Bi = \Delta x/k R''_{t,c}$ ; stability criterion, (b)  $T_{4,2}$  one time step after contact is made if  $Fo = 0.01$  and value of  $\Delta t$ ; whether the stability criterion is satisfied.

**SCHEMATIC:**

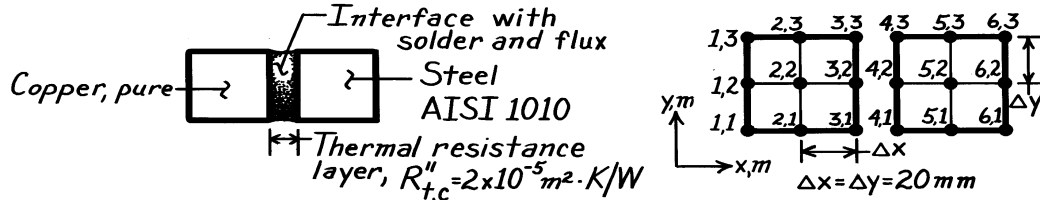

**PROPERTIES:** Table A-1, Steel, AISI 1010 (1000K):  $k = 31.3 \text{ W/m}\cdot\text{K}$ ,  $c = 1168 \text{ J/kg}\cdot\text{K}$ ,  $\rho = 7832 \text{ kg/m}^3$ .

**ASSUMPTIONS:** (1) Two-dimensional transient conduction, (2) Constant properties, (3) Interfacial solder layer has negligible thickness.

**ANALYSIS:** (a) From an energy balance on the control volume  $V = (\Delta x/2) \cdot \Delta y \cdot 1$ .

$$\dot{E}_{in} - \dot{E}_{out} + \dot{E}_g = \dot{E}_{st}$$

$$q_a + q_b + q_c + q_d = \rho c V \frac{T_{4,2}^{p+1} - T_{4,2}^p}{\Delta t}$$

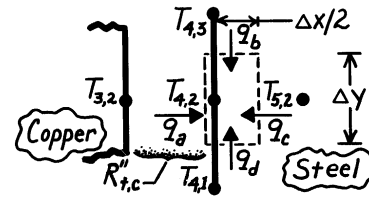

Note that  $q_a = (\Delta T/R''_{t,c}) A_c$  while the remaining  $q_i$  are conduction terms,

$$\frac{1}{R''_{t,c}} (T_{3,2}^p - T_{4,2}^p) \Delta y + k (\Delta x/2) \frac{(T_{4,3}^p - T_{4,2}^p)}{\Delta y} + k (\Delta y) \frac{(T_{5,2}^p - T_{4,2}^p)}{\Delta x} + k (\Delta x/2) \frac{(T_{4,1}^p - T_{4,2}^p)}{\Delta y} = \rho c [(\Delta x/2) \cdot \Delta y] \frac{T_{4,2}^{p+1} - T_{4,2}^p}{\Delta t}$$

Defining  $Fo \equiv (k/\rho c) \Delta t/\Delta x^2$  and  $Bi_c \equiv \Delta y/R''_{t,c} k$ , regroup to obtain

$$T_{4,2}^{p+1} = Fo (T_{4,3}^p + 2T_{5,2}^p + T_{4,1}^p + 2Bi_c T_{3,2}^p) + (1 - 4Fo - 2FoBi_c) T_{4,2}^p \quad <$$

The stability criterion requires the coefficient of the  $T_{4,2}^p$  term be zero or positive,

$$(1 - 4Fo - 2FoBi_c) \geq 0 \quad \text{or} \quad Fo \leq 1/(4 + 2Bi_c) \quad <$$

(b) For  $Fo = 0.01$  and  $Bi = 0.020\text{m}/(2 \times 10^{-5}\text{m}^2 \cdot \text{K/W} \times 31.3\text{W/m}\cdot\text{K}) = 31.95$ ,

$$T_{4,2}^{p+1} = 0.01(1000 + 2 \times 900 + 1000 + 2 \times 31.95 \times 700)\text{K} + (1 - 4 \times 0.01 - 2 \times 0.01 \times 31.95)1000\text{K}$$

$$T_{4,2}^{p+1} = 485.30\text{K} + 321.00\text{K} = 806.3\text{K} \quad <$$

With  $Fo = 0.01$ , the time step is

$$\Delta t = Fo \Delta x^2 (\rho c/k) = 0.01(0.020\text{m})^2 (7832\text{kg/m}^3 \times 1168\text{J/kg}\cdot\text{K}/31.3\text{W/m}\cdot\text{K}) = 1.17\text{s} \quad <$$

With  $Bi = 31.95$  and  $Fo = 0.01$ , the stability criterion,  $Fo \leq 0.015$ , is satisfied. <

### PROBLEM 5.140

**KNOWN:** Flue of square cross-section, initially at a uniform temperature is suddenly exposed to hot flue gases. See Problem 4.92.

**FIND:** Temperature distribution in the wall 5, 10, 50 and 100 hours after introduction of gases using the *implicit* finite-difference method.

**SCHEMATIC:**

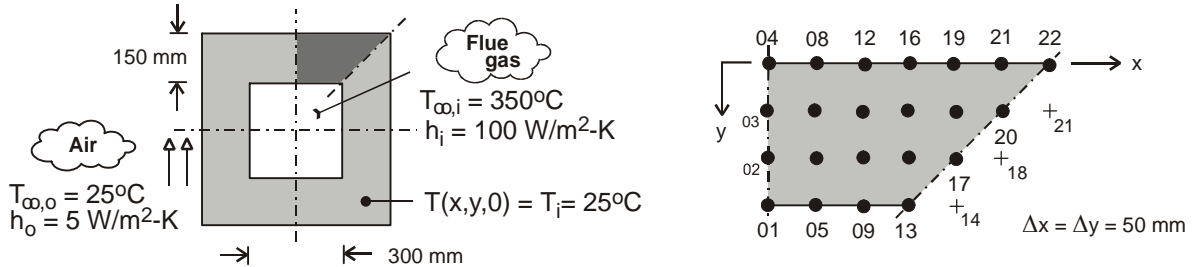

**ASSUMPTIONS:** (1) Two-dimensional transient conduction, (2) Constant properties.

**PROPERTIES:** Flue (given):  $k = 0.85 \text{ W/m}\cdot\text{K}$ ,  $\alpha = 5.5 \times 10^{-7} \text{ m}^2/\text{s}$ .

**ANALYSIS:** The network representing the flue cross-sectional area is shown with  $\Delta x = \Delta y = 50 \text{ mm}$ . Initially all nodes are at  $T_i = 25^\circ\text{C}$  when suddenly the interior and exterior surfaces are exposed to convection processes,  $(T_{\infty,i}, h_i)$  and  $(T_{\infty,o}, h_o)$ , respectively. Referring to the network above, note that there are four types of nodes: interior (02, 03, 06, 07, 10, 11, 14, 15, 17, 18, 20); plane surfaces with convection (interior – 01, 05, 09); interior corner with convection (13), plane surfaces with convection (exterior – 04, 08, 12, 16, 19, 21); and, exterior corner with convection. The system of finite-difference equations representing the network is obtained using *IHT|Tools|Finite-difference equations|Two-dimensional|Transient*. The *IHT* code is shown in Comment 2 and the results for  $t = 5, 10, 50$  and  $100$  hour are tabulated below.

$$\text{Node 17} \quad (1 + 4\text{Fo})T_{17}^{p+1} - \text{Fo}(T_{18}^{p+1} + T_{14}^{p+1} + T_{18}^{p+1} + T_{14}^{p+1}) = T_{17}^p$$

$$\text{Node 13} \quad \left[ 1 + 4\text{Fo} \left[ 1 + \frac{1}{3}\text{Bi}_i \right] \right] T_{13}^{p+1} - \frac{2}{3}\text{Fo}(2T_{14}^{p+1} + T_9 + 2T_{14}^{p+1} + T_9^{p+1}) = T_{13}^p + \frac{4}{3}\text{Bi}_i \cdot \text{Fo} \cdot T_{\infty,i}$$

$$\text{Node 12} \quad (1 + 2\text{Fo}(2 + \text{Bi}_o))T_{12}^{p+1} - \text{Fo}(2T_{11}^{p+1} + T_{16}^{p+1} + T_8^{p+1}) = T_{12}^p + 2\text{Bi}_o \cdot \text{Fo} \cdot T_{\infty,o}$$

$$\text{Node 22} \quad (1 + 4\text{Fo}(1 + \text{Bi}_o))T_{22}^{p+1} - 2\text{Fo}(T_{21}^{p+1} + T_{21}^{p+1}) = T_{22}^p + 4\text{Bi}_o \cdot \text{Fo} \cdot T_{\infty,o}$$

Numerical values for the relevant parameters are:

$$\text{Fo} = \frac{\alpha \Delta t}{\Delta x^2} = \frac{5.5 \times 10^{-6} \text{ m}^2/\text{s} \times 3600 \text{ s}}{(0.050 \text{ m})^2} = 7.92000$$

$$\text{Bi}_o = \frac{h_o \Delta x}{k} = \frac{5 \text{ W/m}^2 \cdot \text{K} \times 0.050 \text{ m}}{0.85 \text{ W/m}\cdot\text{K}} = 0.29412$$

$$\text{Bi}_i = \frac{h_i \Delta x}{k} = \frac{100 \text{ W/m}^2 \cdot \text{K} \times 0.050 \text{ m}}{0.85 \text{ W/m}\cdot\text{K}} = 5.88235$$

The system of FDEs can be represented in matrix notation,  $[A][T] = [C]$ . The coefficient matrix  $[A]$  and terms for the right-hand side matrix  $[C]$  are given on the following page.

Continued ...

**PROBLEM 5.140 (Cont.)**

<i>The coefficient matrix [A]</i>																						<i>RHS matrix [C]</i>	
	1	2	3	4	5	6	7	8	9	10	11	12	13	14	15	16	17	18	19	20	21	22	
1	E	2	0	0	2	0	0	0	0	0	0	0	0	0	0	0	0	0	0	0	0	0	$-0.12626T_1^* - 7331.1765$
2	1	F	1	0	0	2	0	0	0	0	0	0	0	0	0	0	0	0	0	0	0	0	$-0.12626T_2^*$
3	0	1	F	1	0	0	2	0	0	0	0	0	0	0	0	0	0	0	0	0	0	0	$-0.12626T_3^*$
4	0	0	2	G	0	0	0	2	0	0	0	0	0	0	0	0	0	0	0	0	0	0	$-0.12626T_4^* - 175.38235$
5	1	0	0	0	E	2	0	0	1	0	0	0	0	0	0	0	0	0	0	0	0	0	$-0.12626T_5^* - 7331.1765$
6	0	1	0	0	1	F	1	0	0	1	0	0	0	0	0	0	0	0	0	0	0	0	$-0.12626T_6^*$
7	0	0	1	0	0	1	F	1	0	0	1	0	0	0	0	0	0	0	0	0	0	0	$-0.12626T_7^*$
8	0	0	0	1	0	0	2	G	0	0	1	0	0	0	0	0	0	0	0	0	0	0	$-0.12626T_8^* - 175.37235$
9	0	0	0	0	1	0	0	0	E	2	0	0	1	0	0	0	0	0	0	0	0	0	$-0.12626T_9^* - 7331.1765$
10	0	0	0	0	0	1	0	0	1	F	1	0	0	1	0	0	0	0	0	0	0	0	$-0.12626T_{10}^*$
11	0	0	0	0	0	0	1	0	0	1	F	1	0	0	1	0	0	0	0	0	0	0	$-0.12626T_{11}^*$
12	0	0	0	0	0	0	0	1	0	0	2	G	0	0	1	0	0	0	0	0	0	0	$-0.12626T_{12}^* - 175.38235$
13	0	0	0	0	0	0	0	0	4	0	0	0	H	8	0	0	0	0	0	0	0	0	$-0.37879T_{13}^* - 14,658.824$
14	0	0	0	0	0	0	0	0	0	1	0	0	1	F	1	0	1	0	0	0	0	0	$-0.12626T_{14}^*$
15	0	0	0	0	0	0	0	0	0	0	1	0	0	1	F	1	0	1	0	0	0	0	$-0.12626T_{15}^*$
16	0	0	0	0	0	0	0	0	0	0	0	1	0	0	2	G	0	0	1	0	0	0	$-0.12626T_{16}^* - 175.38235$
17	0	0	0	0	0	0	0	0	0	0	0	0	0	2	0	0	F	2	0	0	0	0	$-0.12626T_{17}^*$
18	0	0	0	0	0	0	0	0	0	0	0	0	0	0	1	0	1	F	1	1	0	0	$-0.12626T_{18}^*$
19	0	0	0	0	0	0	0	0	0	0	0	0	0	0	0	1	0	2	G	0	1	0	$-0.12626T_{19}^* - 175.38235$
20	0	0	0	0	0	0	0	0	0	0	0	0	0	0	0	0	0	2	0	F	2	0	$-0.12626T_{20}^*$
21	0	0	0	0	0	0	0	0	0	0	0	0	0	0	0	0	0	0	1	2	G	1	$-0.12626T_{21}^* - 175.38235$
22	0	0	0	0	0	0	0	0	0	0	0	0	0	0	0	0	0	0	0	0	4	K	$-0.12626T_{22}^* - 350.76471$

E = -15.89096    F = -4.12626    G = -4.71450    H = -35.90819    K = -5.30274

For this problem a stock computer program was used to obtain the solution matrix [T]. The initial temperature distribution was  $T_m^0 = 298K$ . The results are tabulated below.

Node/time (h)	T(m,n) (C)				
	0	5	10	50	100
T01	25	335.00	338.90	340.20	340.20
T02	25	248.00	274.30	282.90	282.90
T03	25	179.50	217.40	229.80	229.80
T04	25	135.80	170.30	181.60	181.60
T05	25	334.50	338.50	339.90	339.90
T06	25	245.30	271.90	280.80	280.80
T07	25	176.50	214.60	227.30	227.30
T08	25	133.40	168.00	179.50	179.50
T09	25	332.20	336.60	338.20	338.20
T10	25	235.40	263.40	273.20	273.20
T11	25	166.40	205.40	219.00	219.00
T12	25	125.40	160.40	172.70	172.70
T13	25	316.40	324.30	327.30	327.30
T14	25	211.00	243.00	254.90	254.90
T15	25	146.90	187.60	202.90	202.90
T16	25	110.90	146.70	160.20	160.20
T17	25	159.80	200.50	216.20	216.20
T18	25	117.40	160.50	177.50	177.50
T19	25	90.97	127.40	141.80	141.80
T20	25	90.62	132.20	149.00	149.00
T21	25	72.43	106.70	120.60	120.60
T22	25	59.47	87.37	98.89	98.89

**COMMENTS:** (1) Note that the steady-state condition is reached by  $t = 5$  hours; this can be seen by comparing the distributions for  $t = 50$  and  $100$  hours. Within 10 hours, the flue is within a few degrees of the steady-state condition.

Continued ...

### PROBLEM 5.140 (Cont.)

(2) The *IHT* code for performing the numerical solution is shown in its entirety below. Use has been made of symmetry in writing the FDEs. The tabulated results above were obtained by copying from the *IHT Browser* and pasting the desired columns into EXCEL.

```

// From Tools/Finite-difference equations/Two-dimensional/Transient
// Interior surface nodes, 01, 05, 09, 13
/* Node 01: plane surface node, s-orientation; e, w, n labeled 05, 05, 02 . */
rho * cp * der(T01,t) = fd_2d_psur_s(T01,T05,T05,T02,k,qdot,deltax,deltay,Tinfi,hi,q''a)
q''a = 0 // Applied heat flux, W/m^2; zero flux shown
qdot = 0
rho * cp * der(T05,t) = fd_2d_psur_s(T05,T09,T01,T06,k,qdot,deltax,deltay,Tinfi,hi,q''a)
rho * cp * der(T09,t) = fd_2d_psur_s(T09,T13,T05,T10,k,qdot,deltax,deltay,Tinfi,hi,q''a)
/* Node 13: internal corner node, w-s orientation; e, w, n, s labeled 14, 09, 14, 09. */
rho * cp * der(T13,t) = fd_2d_ic_ws(T13,T14,T09,T14,T09,k,qdot,deltax,deltay,Tinfi,hi,q''a)

// Interior nodes, 02, 03, 06, 07, 10, 11, 14, 15, 18, 20
/* Node 02: interior node; e, w, n, s labeled 06, 06, 03, 01. */
rho * cp * der(T02,t) = fd_2d_int(T02,T06,T06,T03,T01,k,qdot,deltax,deltay)
rho * cp * der(T03,t) = fd_2d_int(T03,T07,T07,T04,T02,k,qdot,deltax,deltay)
rho * cp * der(T06,t) = fd_2d_int(T06,T10,T02,T07,T05,k,qdot,deltax,deltay)
rho * cp * der(T07,t) = fd_2d_int(T07,T11,T03,T08,T06,k,qdot,deltax,deltay)
rho * cp * der(T10,t) = fd_2d_int(T10,T14,T06,T11,T09,k,qdot,deltax,deltay)
rho * cp * der(T11,t) = fd_2d_int(T11,T15,T07,T12,T10,k,qdot,deltax,deltay)
rho * cp * der(T14,t) = fd_2d_int(T14,T17,T10,T15,T13,k,qdot,deltax,deltay)
rho * cp * der(T15,t) = fd_2d_int(T15,T18,T11,T16,T14,k,qdot,deltax,deltay)
rho * cp * der(T17,t) = fd_2d_int(T17,T18,T14,T18,T14,k,qdot,deltax,deltay)
rho * cp * der(T18,t) = fd_2d_int(T18,T20,T15,T19,T17,k,qdot,deltax,deltay)
rho * cp * der(T20,t) = fd_2d_int(T20,T21,T18,T21,T18,k,qdot,deltax,deltay)

// Exterior surface nodes, 04, 08, 12, 16, 19, 21, 22
/* Node 04: plane surface node, n-orientation; e, w, s labeled 08, 08, 03. */
rho * cp * der(T04,t) = fd_2d_psur_n(T04,T08,T08,T03,k,qdot,deltax,deltay,Tinfo,ho,q''a)
rho * cp * der(T08,t) = fd_2d_psur_n(T08,T12,T04,T07,k,qdot,deltax,deltay,Tinfo,ho,q''a)
rho * cp * der(T12,t) = fd_2d_psur_n(T12,T16,T08,T11,k,qdot,deltax,deltay,Tinfo,ho,q''a)
rho * cp * der(T16,t) = fd_2d_psur_n(T16,T19,T12,T15,k,qdot,deltax,deltay,Tinfo,ho,q''a)
rho * cp * der(T19,t) = fd_2d_psur_n(T19,T21,T16,T18,k,qdot,deltax,deltay,Tinfo,ho,q''a)
rho * cp * der(T21,t) = fd_2d_psur_n(T21,T22,T19,T20,k,qdot,deltax,deltay,Tinfo,ho,q''a)
/* Node 22: external corner node, e-n orientation; w, s labeled 21, 21. */
rho * cp * der(T22,t) = fd_2d_ec_en(T22,T21,T21,k,qdot,deltax,deltay,Tinfo,ho,q''a)

// Input variables
deltax = 0.050
deltay = 0.050
Tinfi = 350
hi = 100
Tinfo = 25
ho = 5
k = 0.85
alpha = 5.55e-7
alpha = k / (rho * cp)
rho = 1000 // arbitrary value

```

(3) The results for  $t = 50$  hour, representing the steady-state condition, are shown below, arranged according to the coordinate system.

x/y (mm)	T <sub>mn</sub> (C)						
	0	50	100	150	200	250	300
0	181.60	179.50	172.70	160.20	141.80	120.60	98.89
50	229.80	227.30	219.00	202.90	177.50	149.00	
100	282.90	280.80	273.20	172.70	216.20		
150	340.20	339.90	338.20	327.30			

In Problem 4.92, the temperature distribution was determined using the FDEs written for steady-state conditions, but with a finer network,  $\Delta x = \Delta y = 25$  mm. By comparison, the results for the coarser network are slightly higher, within a fraction of  $1^\circ\text{C}$ , along the mid-section of the flue, but notably higher in the vicinity of inner corner. (For example, node 13 is  $2.6^\circ\text{C}$  higher with the coarser mesh.)



**PROBLEM 5.141 (Cont.)**

Divide by  $k$ , use the following definitions, and regroup to obtain the finite-difference equations.

$$N \equiv h\Delta x/k = 100 \text{ W/m}^2 \cdot \text{K} \times 0.006\text{m}/2 \text{ W/m} \cdot \text{K} = 0.3000 \quad (1)$$

$$Fo \equiv (k/\rho c) \Delta t/\Delta x \cdot \Delta y = \alpha \Delta t/\Delta x \cdot \Delta y =$$

$$1.5 \times 10^{-6} \text{ m}^2 / \text{s} \times 1\text{s} / (0.006 \times 0.002) \text{ m}^2 = 0.1250 \quad (2)$$

$$\begin{aligned} \frac{1}{2} \left[ \frac{\Delta y}{\Delta x} \right] \left( T_1^{p+1} - T_2^{p+1} \right) + N \left( T_\infty - T_2^{p+1} \right) + \frac{1}{2} \left[ \frac{\Delta y}{\Delta x} \right] \left( T_3^{p+1} - T_2^{p+1} \right) \\ + \left[ \frac{\Delta x}{\Delta y} \right] \left( T_5^{p+1} - T_2^{p+1} \right) = \frac{1}{2Fo} \left( T_2^{p+1} - T_2^p \right) \\ \frac{1}{2} \left[ \frac{\Delta y}{\Delta x} \right] T_1^{p+1} - \left[ \left[ \frac{\Delta x}{\Delta y} \right] + N + \left[ \frac{\Delta y}{\Delta x} \right] + \frac{1}{2Fo} \right] T_2^{p+1} + \frac{1}{2} \left[ \frac{\Delta x}{\Delta y} \right] T_3^{p+1} \\ + \left[ \frac{\Delta x}{\Delta y} \right] T_5^{p+1} = -NT_\infty - \frac{1}{2Fo} T_2^p. \end{aligned} \quad (3)$$

Substituting numerical values for  $Fo$  and  $N$ , and using  $T_\infty = 30^\circ\text{C}$  and  $\Delta x/\Delta y = 3$ , find

$$0.16667T_1^{p+1} - 7.63333T_2^{p+1} + 0.16667T_3^{p+1} + 3.00000T_5^{p+1} = 9.0000 - 4.0000T_2^p. \quad (4)$$

By inspection and use of Eq. (3), the FDEs for Nodes 1 and 3 can be inferred.

*Interior Node 7.* From an energy balance on the prescribed control volume with  $\Delta x/\Delta y = 3$ ,

$$\dot{E}'_{in} + \dot{E}'_g = \dot{E}'_{st}$$

where  $\dot{E}'_g = 2q'_{ht}$  and  $\dot{E}'_{in}$  represents the

conduction terms  $-q'_a + q'_b + q'_c + q'_d$ ,

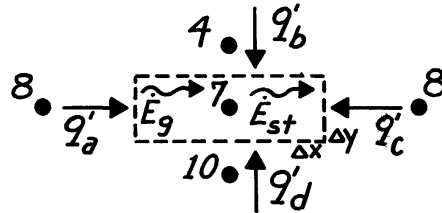

$$\begin{aligned} k\Delta y \frac{T_8^{p+1} - T_7^{p+1}}{\Delta x} + k\Delta x \frac{T_4^{p+1} - T_7^{p+1}}{\Delta y} + k\Delta y \frac{T_8^{p+1} - T_7^{p+1}}{\Delta x} \\ + k\Delta x \frac{T_{10}^{p+1} - T_7^{p+1}}{\Delta y} + 2q'_{ht} = \rho c (\Delta x \cdot \Delta y) \frac{T_7^{p+1} - T_7^p}{\Delta t}. \end{aligned}$$

Using the definition of  $Fo$ , Eq. (2), and regrouping, find

$$\begin{aligned} \frac{1}{2} \left[ \frac{\Delta x}{\Delta y} \right] T_4^{p+1} - \left[ \left[ \frac{\Delta x}{\Delta y} \right] + \left[ \frac{\Delta y}{\Delta x} \right] + \frac{1}{2Fo} \right] T_7^{p+1} \\ + \left[ \frac{\Delta y}{\Delta x} \right] T_8^{p+1} + \frac{1}{2} \left[ \frac{\Delta x}{\Delta y} \right] T_{10}^{p+1} = -\frac{q'_{ht}}{k} - \frac{1}{2Fo} T_7^p \end{aligned} \quad (5)$$

$$1.50000T_4^{p+1} - 7.33333T_7^{p+1} + 0.33333T_8^{p+1} + 1.50000T_{10}^{p+1} = -12.5000 - 4.0000T_7^p. \quad (6)$$

Continued ...

**PROBLEM 5.141 (Cont.)**

Recognizing the form of Eq. (5), it is a simple matter to infer the FDE for the remaining interior points for which  $\dot{q}_{ht} = 0$ . In matrix notation  $[A][T] = [C]$ , the coefficient matrix  $[A]$  and RHS matrix  $[C]$  are:

THE COEFFICIENT MATRIX, [A]											[C]		
-7.633330	0.333330	0	3.000000	0	0	0	0	0	0	0	0	-4.0T <sub>1</sub> <sup>o</sup> - 9.0	
0.166670	-7.633330	0.166670	0	3.000000	0	0	0	0	0	0	0	-4.0T <sub>2</sub> <sup>o</sup> - 9.0	
0	0.333330	-7.633330	0	0	3.000000	0	0	0	0	0	0	-4.0T <sub>3</sub> <sup>o</sup> - 9.0	
1.500000	0	0	-7.333330	0.333330	0	1.500000	0	0	0	0	0	-4.0T <sub>4</sub> <sup>o</sup>	
0	3.000000	0	0.333330	-14.666670	0.333330	0	3.000000	0	0	0	0	-8.0T <sub>5</sub> <sup>o</sup>	
0	0	1.500000	0	0.333330	-7.333330	0	0	1.500000	0	0	0	-4.0T <sub>6</sub> <sup>o</sup>	
0	0	0	1.500000	0	0	-7.333330	0.333330	0	1.500000	0	0	-4.0T <sub>7</sub> <sup>o</sup> - 12.5	
0	0	0	0	3.000000	0	0.333330	-14.666670	0.333330	0	3.000000	0	-8.0T <sub>8</sub> <sup>o</sup>	
0	0	0	0	0	1.500000	0	0.333330	-7.333330	0	0	1.500000	-4.0T <sub>9</sub> <sup>o</sup>	
0	0	0	0	0	0	3.000000	0	0	-7.333330	0.333330	0	-4.0T <sub>10</sub> <sup>o</sup>	
0	0	0	0	0	0	0	0	3.000000	0	0.166670	-7.333330	0.166670	-4.0T <sub>11</sub> <sup>o</sup>
0	0	0	0	0	0	0	0	0	3.000000	0	0.333330	-7.333330	-4.0T <sub>12</sub> <sup>o</sup>

Recall that the problem asks for the time required to reach 95% of the difference for steady-state conditions. This provides information on approximately how long it takes for the plate to come to a steady operating condition. If you worked Problem 4.86, you know the steady-state temperature distribution. Then you can proceed to find the

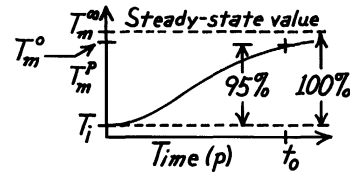

$T_m^P$  values with increasing time until the *first* node reaches the required limit. We should not expect the nodes to reach their limit at the same time.

Not knowing the steady-state temperature distribution, use the implicit FDE in matrix form above to step through time  $\rightarrow \infty$  to the steady-state solution; that is, proceed to  $p \rightarrow 10, 20, \dots, 100$  until the solution matrix  $[T]$  does not change. The results of the analysis are tabulated below. Column 1 labeled  $T_m(\infty)$  is the steady-state distribution. Column 2,  $T_m(95\%)$ , is the 95% limit being sought as per the graph directly above. The third column is the temperature distribution at  $t = t_o = 248s$ ,  $T_m(248s)$ ; at this elapsed time, Node 1 has reached its limit. Can you explain why this node was the first to reach this limit? Which nodes will be the last to reach their limits?

$T_m(\infty)$	$T_m(95\%)$	$T_m(248s)$	<
55.80	54.51	54.51	
49.93	48.93	48.64	
47.67	46.78	46.38	
59.03	57.58	57.64	
51.72	50.63	50.32	
49.19	48.23	47.79	
63.89	62.20	62.42	
52.98	51.83	51.52	
50.14	49.13	48.68	
62.84	61.20	61.35	
53.35	52.18	51.86	
50.46	49.43	48.98	

## PROBLEM 5.142

**KNOWN:** Conditions associated with heat generation in a rectangular fuel element with surface cooling. See Example 5.11.

**FIND:** (a) The temperature distribution 1.5 s after the change in the operating power; compare results with those tabulated in the Example, and (b) Plot the temperature histories at the midplane,  $x = 0$ , and the surface,  $x = L$ , for  $0 \leq t \leq 400$  s; determine the new steady-state temperatures, and approximately how long it takes to reach this condition. Use the finite-element software *FEHT* as your solution tool.

**SCHEMATIC:**

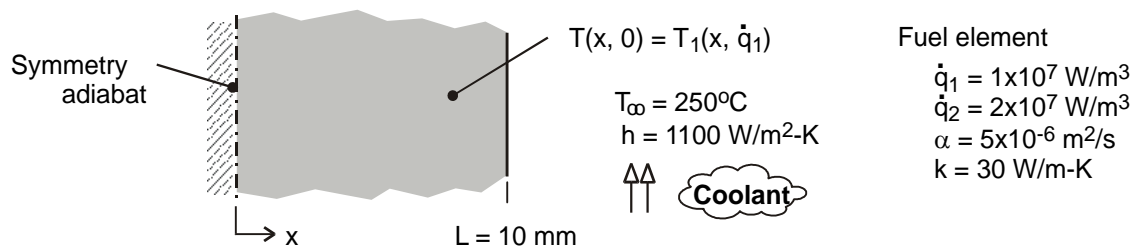

**ASSUMPTIONS:** (1) One-dimensional conduction in the  $x$ -direction, (2) Uniform generation, (3) Constant properties.

**ANALYSIS:** Using *FEHT*, an outline of the fuel element is drawn of thickness 10 mm in the  $x$ -direction and arbitrary length in the  $y$ -direction. The boundary conditions are specified as follows: on the  $y$ -planes and the  $x = 0$  plane, treat as adiabatic; on the  $x = 10$  mm plane, specify the convection option. Specify the material properties and the internal generation with  $\dot{q}_1$ . In the *Setup* menu, click on *Steady-state*, and then *Run* to obtain the temperature distribution corresponding to the initial temperature distribution,  $T_1(x, 0) = T(x, \dot{q}_1)$ , before the change in operating power to  $\dot{q}_2$ .

Next, in the *Setup* menu, click on *Transient*; in the *Specify / Internal Generation* box, change the value to  $\dot{q}_2$ ; and in the *Run* command, click on *Continue* (not *Calculate*).

(a) The temperature distribution 1.5 s after the change in operating power from the *FEHT* analysis and from the *FDE* analysis in the Example are tabulated below.

$x/L$	0	0.2	0.4	0.6	0.8	1.0
$T(x/L, 1.5 \text{ s})$						
FEHT ( $^{\circ}\text{C}$ )	360.1	359.4	357.4	354.1	349.3	343.2
FDE ( $^{\circ}\text{C}$ )	360.08	359.41	357.41	354.07	349.37	343.27

The mesh spacing for the *FEHT* analysis was 0.5 mm and the time increment was 0.005 s. For the *FDE* analyses, the spatial and time increments were 2 mm and 0.3 s. The agreement between the results from the two numerical methods is within 0.1 $^{\circ}\text{C}$ .

(b) Using the *FEHT* code, the temperature histories at the mid-plane ( $x = 0$ ) and the surface ( $x = L$ ) are plotted as a function of time.

Continued ...



## PROBLEM 5.142 (Cont.)

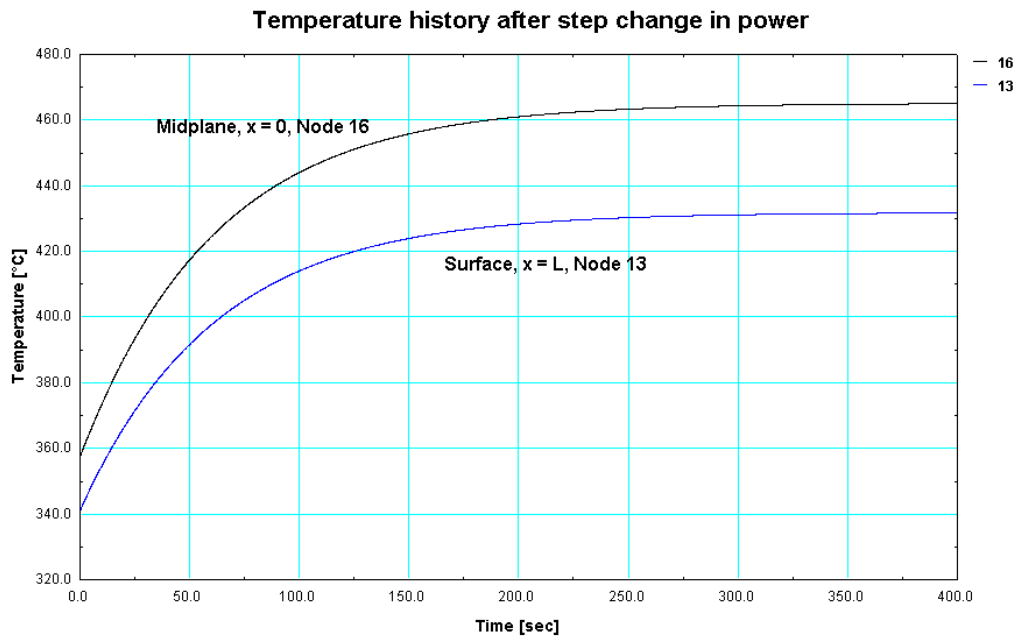

From the distribution, the steady-state condition (based upon 98% change) is approached in 215 s. The steady-state temperature distributions after the step change in power from the FEHT and FDE analysis in the Example are tabulated below. The agreement between the results from the two numerical methods is within 0.1°C

x/L	0	0.2	0.4	0.6	0.8	1.0
T(x/L, ∞)						
FEHT (°C)	465.0	463.7	459.6	453.0	443.6	431.7
FDE (°C)	465.15	463.82	459.82	453.15	443.82	431.82

**COMMENTS:** (1) For background information on the *Continue* option, see the *Run* menu in the *FEHT Help* section. Using the *Run/Calculate* command, the steady-state temperature distribution was determined for the  $\dot{q}_1$  operating power. Using the *Run/Continue* command (after re-setting the generation to  $\dot{q}_2$  and clicking on *Setup / Transient*), this steady-state distribution automatically becomes the initial temperature distribution for the  $\dot{q}_2$  operating power. This feature allows for conveniently prescribing a non-uniform initial temperature distribution for a transient analysis (rather than specifying values on a node-by-node basis).

(2) Use the *View | Tabular Output* command to obtain nodal temperatures to the maximum number of significant figures resulting from the analysis.

(3) Can you validate the new steady-state nodal temperatures from part (b) (with  $\dot{q}_2$ ,  $t \rightarrow \infty$ ) by comparison against an analytical solution?

### PROBLEM 5.143

**KNOWN:** Thick slab of copper as treated in Example 5.12, initially at a uniform temperature, is suddenly exposed to large surroundings at 1000°C (instead of a net radiant flux).

**FIND:** (a) The temperatures  $T(0, 120 \text{ s})$  and  $T(0.15 \text{ m}, 120 \text{ s})$  using the finite-element software *FEHT* for a surface emissivity of 0.94 and (b) Plot the temperature histories for  $x = 0, 150$  and  $600 \text{ mm}$ , and explain key features of your results.

**SCHEMATIC:**

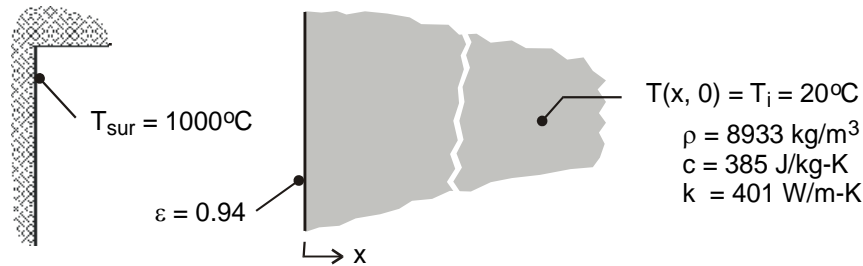

**ASSUMPTIONS:** (1) One-dimensional conduction in the  $x$ -direction, (2) Slab of thickness 600 mm approximates a semi-infinite medium, (3) Slab is small object in large, isothermal surroundings.

**ANALYSIS:** (a) Using *FEHT*, an outline of the slab is drawn of thickness 600 mm in the  $x$ -direction and arbitrary length in the  $y$ -direction. Click on *Setup | Temperatures in K*, to enter all temperatures in kelvins. The boundary conditions are specified as follows: on the  $y$ -planes and the  $x = 600 \text{ mm}$  plane, treat as adiabatic; on the surface  $(0, y)$ , select the convection coefficient option, enter the linearized radiation coefficient after Eq. 1.9 written as

$$0.94 * 5.67e-8 * (T + 1273) * (T^2 + 1273^2)$$

and enter the surroundings temperature, 1273 K, in the fluid temperature box. See the Comments for a view of the input screen. From *View/Temperatures*, find the results:

$$T(0, 120 \text{ s}) = 339 \text{ K} = 66^\circ\text{C} \quad T(150 \text{ mm}, 120 \text{ s}) = 305 \text{ K} = 32^\circ\text{C} \quad <$$

(b) Using the *View | Temperatures* command, the temperature histories for  $x = 0, 150$  and  $600 \text{ mm}$  (10 mm mesh, Nodes 18, 23 and 15, respectively) are plotted. As expected, the surface temperature increases markedly at early times. As thermal penetration increases with increasing time, the temperature at the location  $x = 150 \text{ mm}$  begins to increase after about 30 s. Note, however, that the temperature at the location  $x = 600 \text{ mm}$  does not change significantly within the 150 s exposure to the hot surroundings. Our assumption of treating the boundary at the  $x = 600 \text{ mm}$  plane as adiabatic is justified. A copper plate of 600 mm is a good approximation to a semi-infinite medium at times less than 150 s.

Continued ...

## PROBLEM 5.143 (Cont.)

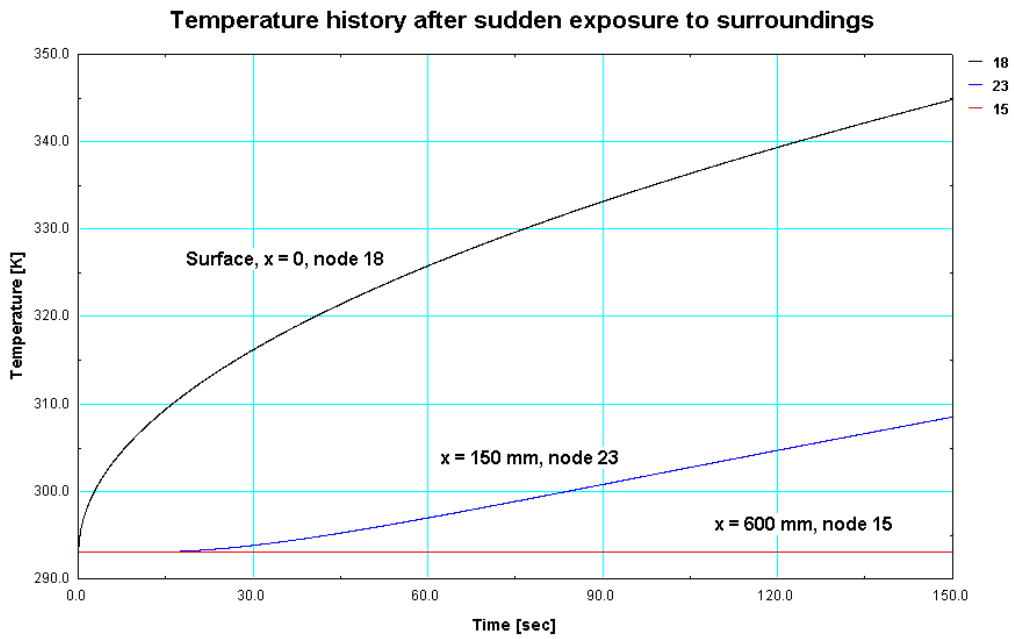

**COMMENTS:** The annotated *Input* screen shows the outline of the slab, the boundary conditions, and the triangular mesh before using the *Reduce-mesh* option.

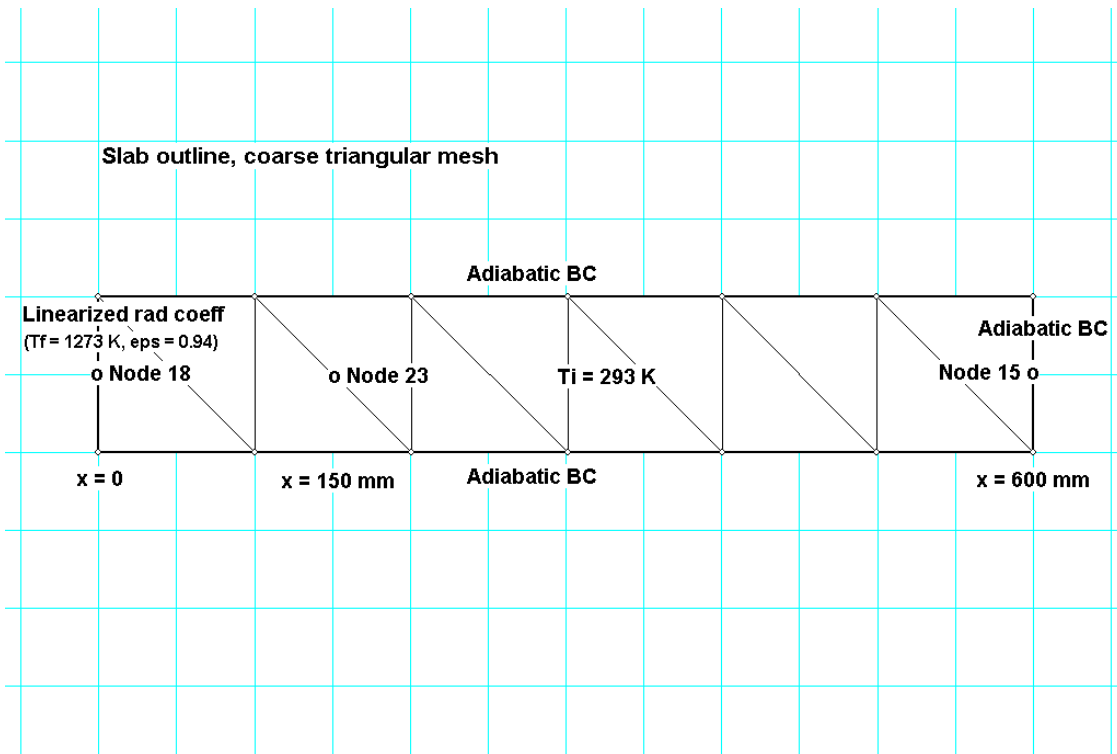

## PPROBLEM 5.144

**KNOWN:** Electric heater sandwiched between two thick plates whose surfaces experience convection. Case 2 corresponds to steady-state operation with a loss of coolant on the  $x = -L$  surface. Suddenly, a second loss of coolant condition occurs on the  $x = +L$  surface, but the heater remains energized for the next 15 minutes. Case 3 corresponds to the eventual steady-state condition following the second loss of coolant event. See Problem 2.53.

**FIND:** Calculate and plot the temperature time histories at the plate locations  $x = 0, \pm L$  during the transient period between steady-state distributions for Case 2 and Case 3 using the finite-element approach with *FEHT* and the finite-difference method of solution with *IHT* ( $\Delta x = 5 \text{ mm}$  and  $\Delta t = 1 \text{ s}$ ).

**SCHEMATIC:**

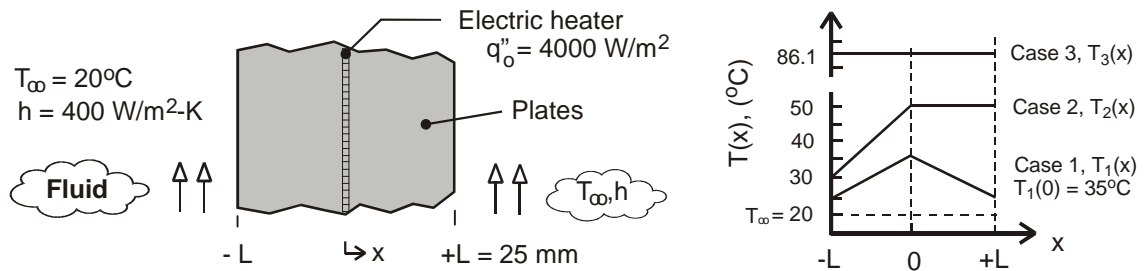

**ASSUMPTIONS:** (1) One-dimensional conduction, (2) Constant properties, (3) Heater has negligible thickness, and (4) Negligible thermal resistance between the heater surfaces and the plates.

**PROPERTIES:** Plate material (*given*);  $\rho = 2500 \text{ kg/m}^3$ ,  $c = 700 \text{ J/kg}\cdot\text{K}$ ,  $k = 5 \text{ W/m}\cdot\text{K}$ .

**ANALYSIS:** The temperature distribution for Case 2 shown in the above graph represents the initial condition for the period of time following the second loss of coolant event. The boundary conditions at  $x = \pm L$  are adiabatic, and the heater flux is maintained at  $\dot{q}_0'' = 4000 \text{ W/m}^2$  for  $0 \leq t \leq 15 \text{ min}$ .

Using *FEHT*, the heater is represented as a plate of thickness  $L_h = 0.5 \text{ mm}$  with very low thermal capacitance ( $\rho = 1 \text{ kg/m}$  and  $c = 1 \text{ J/kg}\cdot\text{K}$ ), very high thermal conductivity ( $k = 10,000 \text{ W/m}\cdot\text{K}$ ), and a uniform volumetric generation rate of  $\dot{q} = \dot{q}_0'' / L_h = 4000 \text{ W/m}^2 / 0.0005 \text{ m} = 8.0 \times 10^6 \text{ W/m}^3$  for  $0 \leq t \leq 900 \text{ s}$ . In the *Specify | Generation* box, the generation was prescribed by the *lookup file* (see *FEHT Help*): 'hfvst',1,2,Time. This *Notepad* file is comprised of four lines, with the values on each line separated by a single tab space:

```

0      8e6
900    8e6
901    0
5000   0
    
```

The temperature-time histories are shown in the graph below for the surfaces  $x = -L$  (lowest curve, 13) and  $x = +L$  (19) and the center point  $x = 0$  (highest curve, 14). The center point experiences the maximum temperature of  $89^\circ\text{C}$  at the time the heater is deactivated,  $t = 900 \text{ s}$ .

Continued ...

### PROBLEM 5.144 (Cont.)

For the finite-difference method of solution, the nodal arrangement for the system is shown below. The *IHT* model builder *Tools | Finite-Difference Equations | One Dimensional* can be used to obtain the FDEs for the internal nodes (02-04, 07-10) and the adiabatic boundary nodes (01, 11).

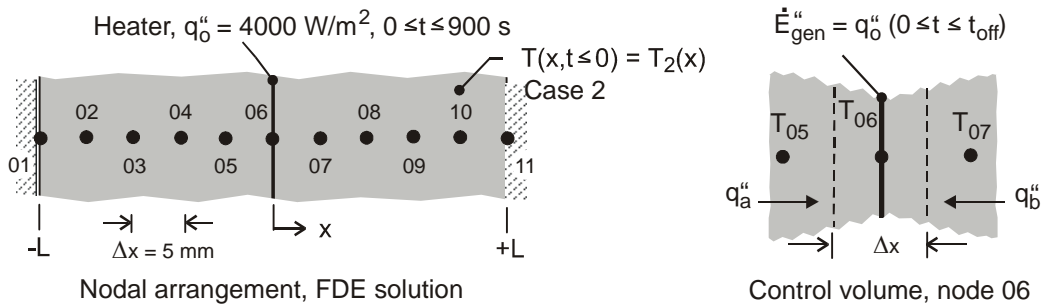
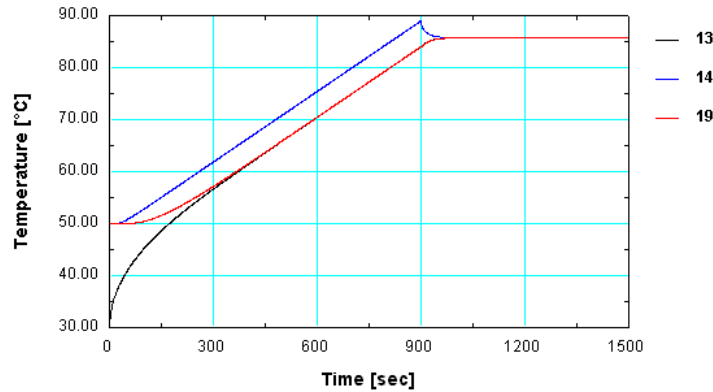

For the heater-plate interface node 06, the FDE for the implicit method is derived from an energy balance on the control volume shown in the schematic above.

$$\begin{aligned} \dot{E}_{in}'' - \dot{E}_{out}'' + \dot{E}_{gen}'' &= \dot{E}_{st}'' \\ q_a'' + q_b'' + q_o'' &= \dot{E}_{st}'' \\ k \frac{T_{05}^{p+1} - T_{06}^{p+1}}{\Delta x} + k \frac{T_{07}^{p+1} - T_{06}^{p+1}}{\Delta x} + q_o'' &= \rho c \Delta x \frac{T_{06}^{p+1} - T_{06}^p}{\Delta t} \end{aligned}$$

The *IHT* code representing selected nodes is shown below for the adiabatic boundary node 01, interior node 02, and the heater-plates interface node 06. Note how the foregoing derived finite-difference equation in implicit form is written in the *IHT Workspace*. Note also the use of a *Lookup Table* for representing the heater flux vs. time.

Continued ...

## PROBLEM 5.144 (Cont.)

```

// Finite-difference equations from Tools, Nodes 01, 02
/* Node 01: surface node (w-orientation); transient conditions; e labeled 02. */
rho * cp * der(T01,t) = fd_1d_sur_w(T01,T02,k,qdot,deltax,Tinf01,h01,q"a01)
q"a01 = 0           // Applied heat flux, W/m^2; zero flux shown
qdot = 0           // No internal generation
Tinf01 = 20        // Arbitrary value
h01 = 1e-6         // Causes boundary to behave as adiabatic

/* Node 02: interior node; e and w labeled 03 and 01. */
rho*cp*der(T02,t) = fd_1d_int(T02,T03,T01,k,qdot,deltax)

// Finite-difference equation from energy balance on CV, Node 06
k * (T05 - T06) / deltax + k * (T07 - T06) / deltax + q"h = rho * cp * deltax * der(T06,t)
q"h = LOOKUPVAL(qhvt,1,t,2) // Heater flux, W/m^2; specified by Lookup Table

/* See HELP (Solver, Lookup Tables). The Look-up table file name "qhvt" contains
0      4000
900    4000
900.5  0
5000   0      */

```

The temperature-time histories using the *IHT* code for the plate locations  $x = 0, \pm L$  are shown in the graphs below. We chose to show expanded presentations of the histories at early times, just after the second loss of coolant event,  $t = 0$ , and around the time the heater is deactivated,  $t = 900$  s.

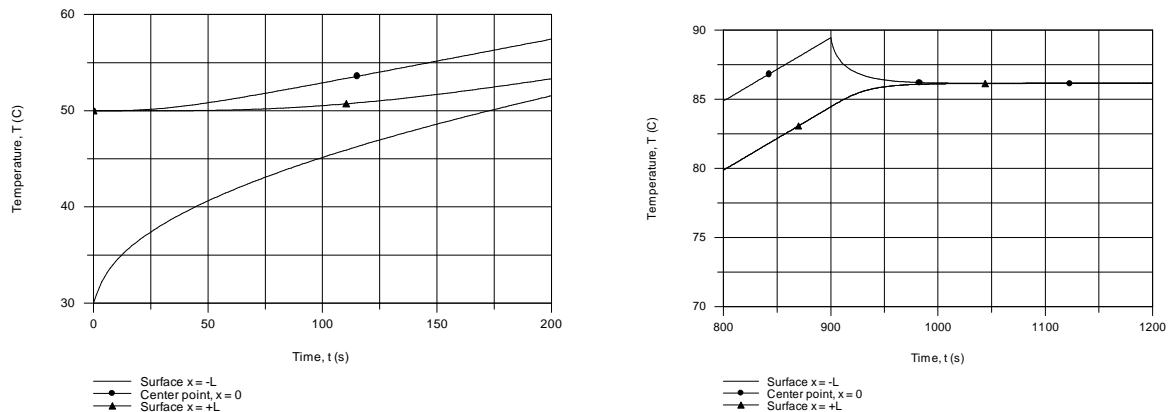

COMMENTS: (1) The maximum temperature during the transient period is at the center point and occurs at the instant the heater is deactivated,  $T(0, 900\text{s}) = 89^\circ\text{C}$ . After 300 s, note that the two surface temperatures are nearly the same, and never rise above the final steady-state temperature.

(2) Both the FEHT and IHT methods of solution give identical results. Their steady-state solutions agree with the result of an energy balance on a time interval basis yielding  $T_{ss} = 86.1^\circ\text{C}$ .

### PROBLEM 5.145

**KNOWN:** Reaction and composite clutch plates, initially at a uniform temperature,  $T_i = 40^\circ\text{C}$ , are subjected to the frictional-heat flux shown in the engagement energy curve,  $q_f''$  vs.  $t$ .

**FIND:** (a) On T-t coordinates, sketch the temperature histories at the mid-plane of the reaction plate, at the interface between the clutch pair, and at the mid-plane of the composite plate; identify key features; (b) Perform an energy balance on the clutch pair over a time interval basis and calculate the steady-state temperature resulting from a clutch engagement; (c) Obtain the temperature histories using the finite-element approach with *FEHT* and the finite-difference method of solution with *IHT* ( $\Delta x = 0.1$  mm and  $\Delta t = 1$  ms). Calculate and plot the frictional heat fluxes to the reaction and composite plates,  $q_{rp}''$  and  $q_{cp}''$ , respectively, as a function of time. Comment on the features of the temperature and frictional-heat flux histories.

**SCHEMATIC:**

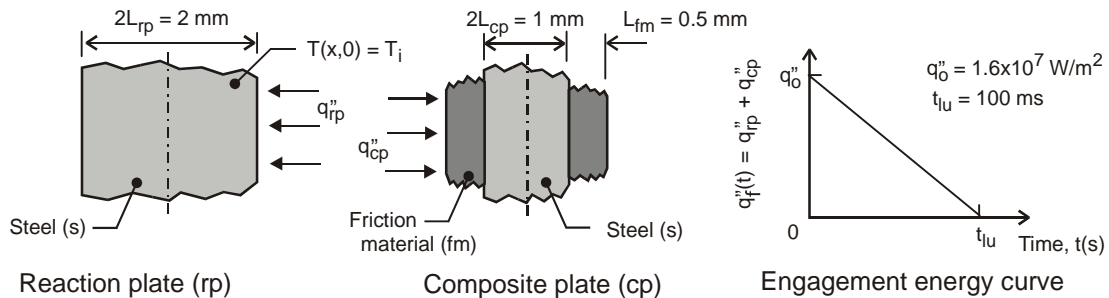

**ASSUMPTIONS:** (1) One-dimensional conduction, (2) Negligible heat transfer to the surroundings.

**PROPERTIES:** Steel,  $\rho_s = 7800$  kg/m<sup>3</sup>,  $c_s = 500$  J/kg·K,  $k_s = 40$  W/m·K; Friction material,  $\rho_{fm} = 1150$  kg/m<sup>3</sup>,  $c_{fm} = 1650$  J/kg·K, and  $k_{fm} = 4$  W/m·K.

**ANALYSIS:** (a) The temperature histories for specified locations in the system are sketched on T-t coordinates below.

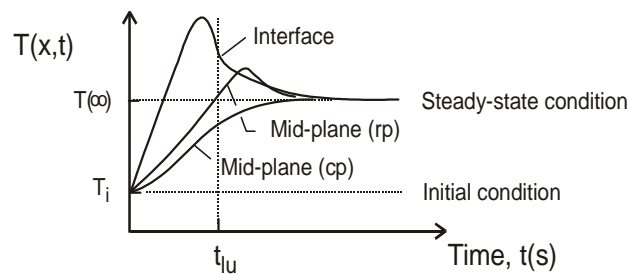

Initially, the temperature at all locations is uniform at  $T_i$ . Since there is negligible heat transfer to the surroundings, eventually the system will reach a uniform, steady-state temperature  $T(\infty)$ . During the engagement period, the interface temperature increases much more rapidly than at the mid-planes of the reaction (rp) and composite (cp) plates. The interface temperature should be the maximum within the system and could occur before lock-up,  $t = t_{lu}$ .

Continued ...

### PROBLEM 5.145 (Cont.)

(b) To determine the steady-state temperature following the engagement period, apply the conservation of energy requirement on the clutch pair on a time-interval basis, Eq. 1.12b.

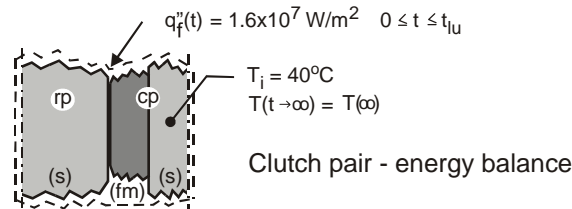

The final and initial states correspond to uniform temperatures of  $T(\infty)$  and  $T_i$ , respectively. The energy input is determined from the engagement energy curve,  $q_f''$  vs.  $t$ .

$$E_{in}'' - E_{out}'' + E_{gen}'' = \Delta E_{st}'' \quad E_{in}'' = E_{out}'' = 0$$

$$\int_0^{t_{lu}} q_f''(t) dt = E_f'' - E_i'' = \left[ \rho_s c_s (L_{rp}/2 + L_{cp}/2) + \rho_{fm} c_{fm} L_{fm} \right] (T_f - T_i)$$

Substituting numerical values, with  $T_i = 40^\circ\text{C}$  and  $T_f = T(\infty)$ .

$$0.5 q_0'' t_{lu} = \left[ \rho_s c_s (L_{rp}/2 + L_{cp}/2) + \rho_{fm} c_{fm} L_{fm} \right] (T(\infty) - T_i)$$

$$0.5 \times 1.6 \times 10^7 \text{ W/m}^2 \times 0.100 \text{ s} = \left[ 7800 \text{ kg/m}^3 \times 500 \text{ J/kg} \cdot \text{K} (0.001 + 0.0005) \text{ m} + 1150 \text{ kg/m}^3 \times 1650 \text{ J/kg} \cdot \text{K} \times 0.0005 \text{ m} \right] (T(\infty) - 40)^\circ\text{C}$$

$$T(\infty) = 158^\circ\text{C}$$

<

(c) *Finite-element method of solution, FEHT.* The clutch pair is comprised of the reaction plate (1 mm), an interface region (0.1 mm), and the composite plate (cp) as shown below.

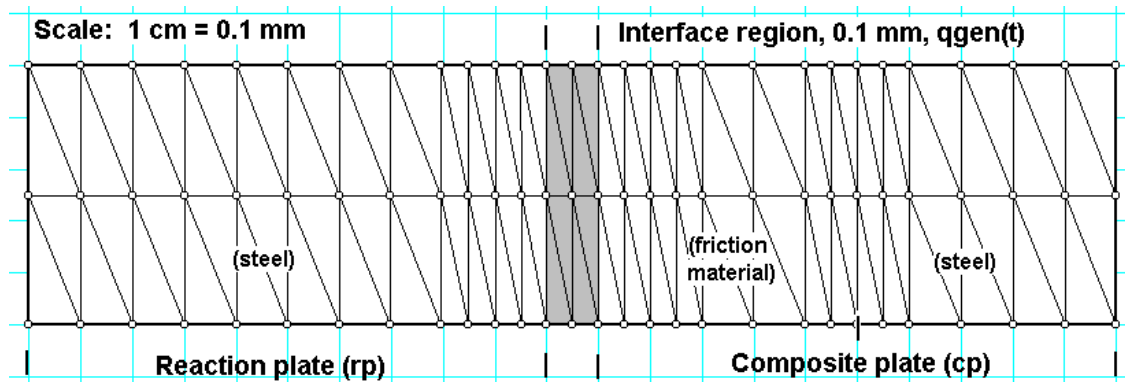

Continued ...



### PROBLEM 5.145 (Cont.)

The external boundaries of the system are made adiabatic. The interface region provides the means to represent the frictional heat flux, specified with negligible thermal resistance and capacitance. The generation rate is prescribed as

$$\dot{q} = 1.6 \times 10^{11} (1 - \text{Time}/0.1) \text{ W/m}^3 \quad 0 \leq \text{Time} \leq t_{lu}$$

where the first coefficient is evaluated as  $q''_0 / 0.1 \times 10^{-3} \text{ m}$  and the 0.1 mm parameter is the thickness of the region. Using the *Run* command, the integration is performed from 0 to 0.1 s with a time step of  $1 \times 10^{-6} \text{ s}$ . Then, using the *Specify/Generation* command, the generation rate is set to zero and the *Run/Continue* command is executed. The temperature history is shown below.

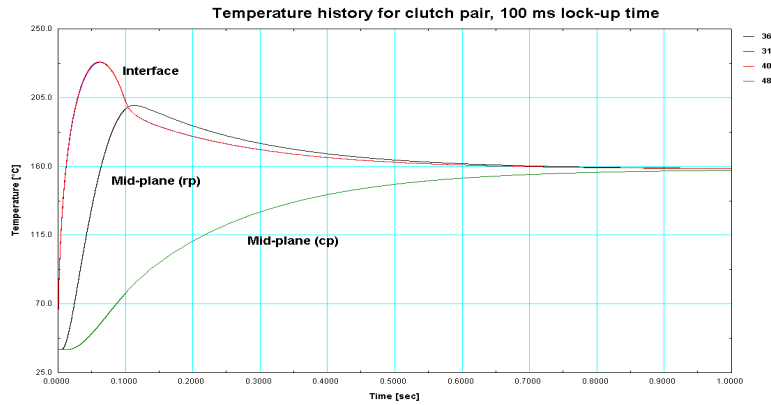

(c) *Finite-difference method of solution, IHT.* The nodal arrangement for the clutch pair is shown below with  $\Delta x = 0.1 \text{ mm}$  and  $\Delta t = 1 \text{ ms}$ . Nodes 02-10, 13-16 and 18-21 are interior nodes, and their finite-difference equations (FDE) can be called into the *Workspace* using *Tools/Finite Difference Equations/One-Dimensional/Transient*. Nodes 01 and 22 represent the mid-planes for the reaction and composite plates, respectively, with adiabatic boundaries. The FDE for node 17 is derived from an energy balance on its control volume (CV) considering different properties in each half of the CV. The FDE for node 11 and 12 are likewise derived using energy balances on their CVs. At the interface, the following conditions must be satisfied

$$T_{11} = T_{12} \quad q''_f = q''_{rp} + q''_{cp}$$

The frictional heat flux is represented by a *Lookup Table*, which along with the FDEs, are shown in the *IHT* code listed in Comment 2.

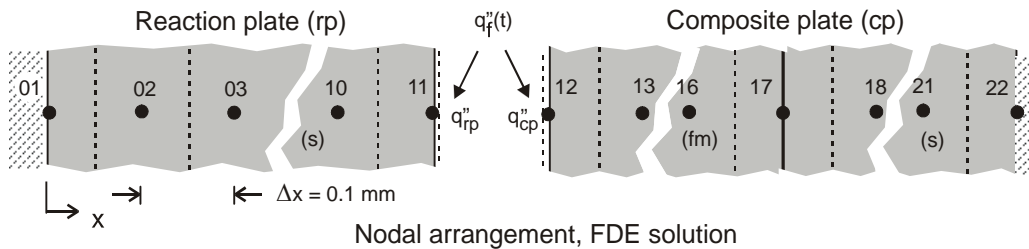

Continued ...

## PROBLEM 5.145 (Cont.)

The temperature and heat flux histories are plotted below. The steady-state temperature was found as 156.5° C, which is in reasonable agreement with the energy balance result from part (a).

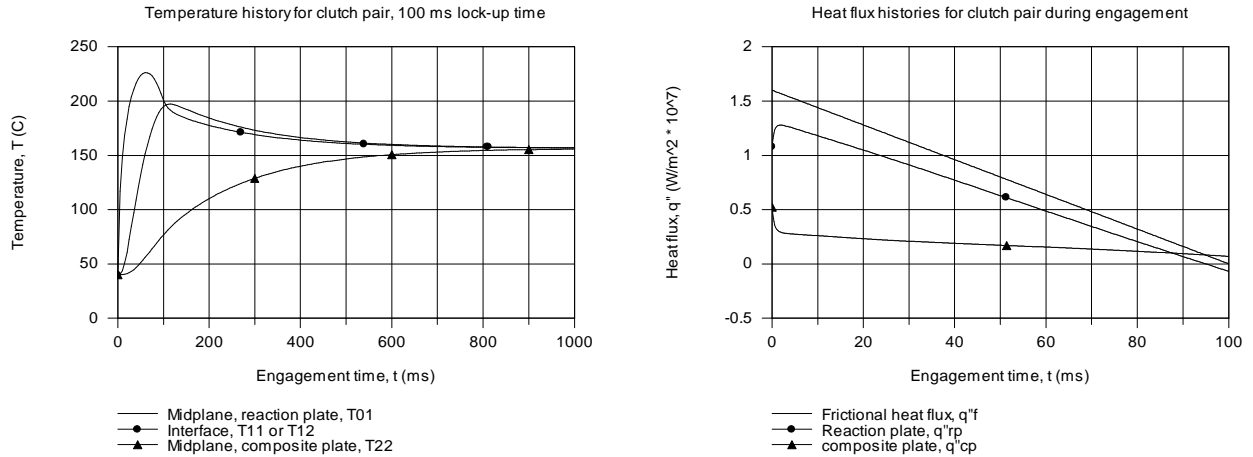

**COMMENTS:** (1) The temperature histories resulting from the FEHT and IHT based solutions are in agreement. The interface temperature peaks near 225°C after 75 ms, and begins dropping toward the steady-state condition. The mid-plane of the reaction plate peaks around 100 ms, nearly reaching 200°C. The temperature of the mid-plane of the composite plate increases slowly toward the steady-state condition.

(2) The calculated temperature-time histories for the clutch pair display similar features as expected from our initial sketches on T vs. t coordinates, part a. The maximum temperature for the composite is very high, subjecting the bonded frictional material to high thermal stresses as well as accelerating deterioration. For the reaction steel plate, the temperatures are moderate, but there is a significant gradient that could give rise to thermal stresses and hence, warping. Note that for the composite plate, the steel section is nearly isothermal and is less likely to experience warping.

(2) The *IHT* code representing the FDE for the 22 nodes and the frictional heat flux relation is shown below. Note use of the *Lookup Table* for representing the frictional heat flux vs. time boundary condition for nodes 11 and 12.

```
// Nodal equations, reaction plate (steel)
/* Node 01: surface node (w-orientation); transient conditions; e labeled 02. */
rho_s * cps * der(T01,t) = fd_1d_sur_w(T01,T02,ks,qdot,deltax,Tinf01,h01,q''a01)
q''a01 = 0 // Applied heat flux, W/m^2; zero flux shown
Tinf01 = 40 // Arbitrary value
h01 = 1e-5 // Causes boundary to behave as adiabatic
qdot = 0
/* Node 02: interior node; e and w labeled 03 and 01. */
rho_s*cps*der(T02,t) = fd_1d_int(T02,T03,T01,ks,qdot,deltax)
.....
/* Node 10: interior node; e and w labeled 11 and 09. */
rho_s*cps*der(T10,t) = fd_1d_int(T10,T11,T09,ks,qdot,deltax)
/* Node 11: From an energy on the CV about node 11 */
ks * (T10 - T11) / deltax + q''rp = rho_s * cps * deltax / 2 * der(T11,t)
```

Continued ...

## PROBLEM 5.145 (Cont.)

### // Friction-surface interface conditions

```
T11 = T12
q"f = LOOKUPVAL(HFVST16,1,t,2) // Applied heat flux, W/m^2; specified by Lookup Table
/* See HELP (Solver, Lookup Tables). The look-up table, file name "HFVST16" contains
      0      16e6
      0.1    0
      100    0      */
q"rp + q"cp = q"f // Frictional heat flux
```

### // Nodal equations - composite plate

```
// Frictional material, nodes 12-16
/* Node 12: From an energy on the CV about node 12 */
kfm * (T13 - T12) / deltax + q"cp = rhofm * cpfm * deltax / 2 * der(T12,t)
/* Node 13: interior node; e and w labeled 08 and 06. */
rhofm*cpfm*der(T13,t) = fd_1d_int(T13,T14,T12,kfm,qdot,deltax)
.....
/* Node 16: interior node; e and w labeled 11 and 09. */
rhofm*cpfm*der(T16,t) = fd_1d_int(T16,T17,T15,kfm,qdot,deltax)
// Interface between friction material and steel, node 17
/* Node 17: From an energy on the CV about node 17 */
kfm * (T16 - T17) / deltax + ks * (T18 - T17) / deltax = RHS
RHS = ( (rhofm * cpfm * deltax / 2) + (rhos * cps * deltax / 2) ) * der(T17,t)
// Steel, nodes 18-22
/* Node 18: interior node; e and w labeled 03 and 01. */
rhos*cps*der(T18,t) = fd_1d_int(T18,T19,T17,ks,qdot,deltax)
.....
/* Node 22: interior node; e and w labeled 21 and 21. Symmetry condition. */
rhos*cps*der(T22,t) = fd_1d_int(T22,T21,T21,ks,qdot,deltax)
// qdot = 0
```

### // Input variables

```
// Ti = 40 // Initial temperature; entered during Solve
deltax = 0.0001
rhos = 7800 // Steel properties
cps = 500
ks = 40
rhofm = 1150 //Friction material properties
cpfm = 1650
kfm = 4
```

### // Conversions, to facilitate graphing

```
t_ms = t * 1000
qf_7 = q"f / 1e7
qrp_7 = q"rp / 1e7
qcp_7 = q"cp / 1e7
```

### PROBLEM 5.146

**KNOWN:** A process mixture at 200°C flows at a rate of 207 kg/min onto a 1-m wide conveyor belt traveling with a velocity of 36 m/min. The underside of the belt is cooled by a water spray.

**FIND:** The surface temperature of the mixture at the end of the conveyor belt,  $T_{e,s}$ , using (a) *IHT* for writing and solving the FDEs, and (b) *FEHT*. Validate your numerical codes against an appropriate analytical method of solution.

**SCHEMATIC:**

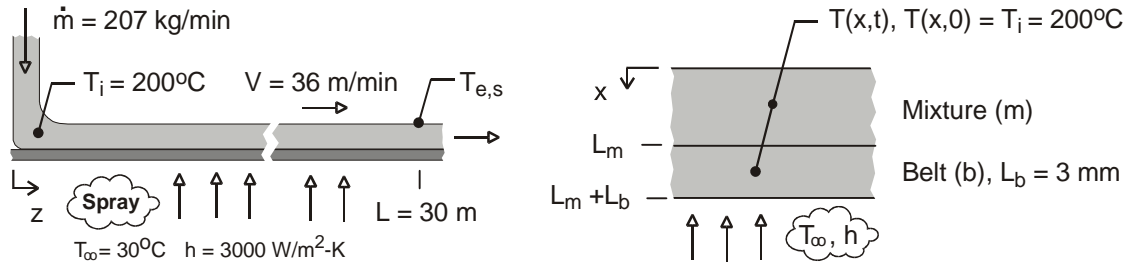

**ASSUMPTIONS:** (1) One-dimensional conduction in the  $x$ -direction at any  $z$ -location, (2) Negligible heat transfer from mixture upper surface to ambient air, and (3) Constant properties.

**PROPERTIES:** Process mixture (m),  $\rho_m = 960 \text{ kg/m}^3$ ,  $c_m = 1700 \text{ J/kg}\cdot\text{K}$ , and  $k_m = 1.5 \text{ W/m}\cdot\text{K}$ ; Conveyor belt (b),  $\rho_b = 8000 \text{ kg/m}^3$ ,  $c_b = 460 \text{ J/kg}\cdot\text{K}$ , and  $k_b = 15 \text{ W/m}\cdot\text{K}$ .

**ANALYSIS:** From the conservation of mass requirement, the thickness of the mixture on the conveyor belt can be determined.

$$\dot{m} = \rho_m A_c V \quad \text{where} \quad A_c = W L_m$$

$$207 \text{ kg/min} \times 1 \text{ min}/60 \text{ s} = 960 \text{ kg/m}^3 \times 1 \text{ m} \times L_m \times 36 \text{ m/min} \times 1 \text{ min}/60 \text{ s}$$

$$L_m = 0.0060 \text{ m} = 6 \text{ mm}$$

The time that the mixture is in contact with the steel conveyor belt, referred to as the residence time, is

$$t_{\text{res}} = L_c / V = 30 \text{ m} / (36 \text{ m/min} \times 1 \text{ min}/60 \text{ s}) = 50 \text{ s}$$

The composite system comprised of the belt,  $L_b = 3 \text{ mm}$ , and mixture,  $L_m = 6 \text{ mm}$ , as represented in the schematic above, is initially at a uniform temperature  $T(x,0) = T_i = 200^\circ\text{C}$  while at location  $z = 0$ , and suddenly is exposed to convection cooling ( $T_\infty, h$ ). We will calculate the mixture upper surface temperature after 50 s,  $T(0, t_{\text{res}}) = T_{e,s}$ .

(a) The nodal arrangement for the composite system is shown in the schematic below. The *IHT* model builder *Tools/Finite-Difference Equations/Transient* can be used to obtain the FDEs for nodes 01-12 and 14-19.

Continued ...

**PROBLEM 5.146 (Cont.)**

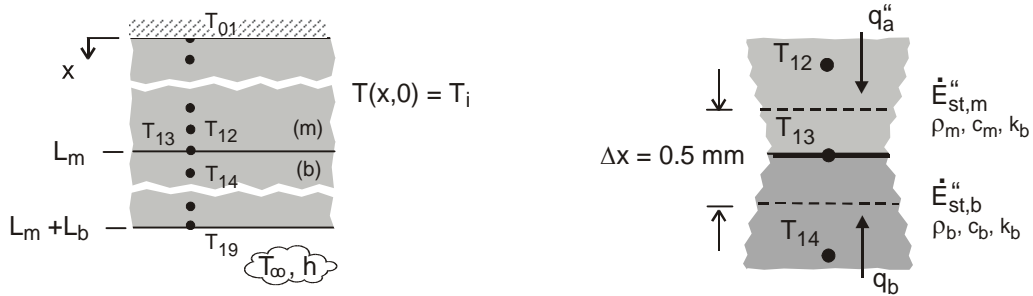

For the mixture-belt interface node 13, the FDE for the implicit method is derived from an energy balance on the control volume about the node as shown above.

$$\dot{E}_{\text{in}}'' - \dot{E}_{\text{out}}'' = \dot{E}_{\text{st}}''$$

$$q_a'' + q_b'' = \dot{E}_{\text{st},m}'' + \dot{E}_{\text{st},b}''$$

$$k_m \frac{T_{12}^{p+1} - T_{13}^{p+1}}{\Delta x} + k_b \frac{T_{14}^{p+1} - T_{13}^{p+1}}{\Delta x} = (\rho_m c_m + \rho_b c_b) (\Delta x / 2) \frac{T_{13}^{p+1} - T_{13}^p}{\Delta t}$$

*IHT* code representing selected FDEs, nodes 01, 02, 13 and 19, is shown in Comment 4 below ( $\Delta x = 0.5 \text{ mm}$ ,  $\Delta t = 0.1 \text{ s}$ ). Note how the FDE for node 13 derived above is written in the *Workspace*. From the analysis, find

$$T_{e,s} = T(0, 50s) = 54.8^\circ\text{C} \quad <$$

(b) Using *FEHT*, the composite system is drawn and the material properties, boundary conditions, and initial temperature are specified. The screen representing the system is shown below in Comment 5 with annotations on key features. From the analysis, find

$$T_{e,s} = T(0, 50s) = 54.7^\circ\text{C} \quad <$$

**COMMENTS:** (1) Both numerical methods, *IHT* and *FEHT*, yielded the same result,  $55^\circ\text{C}$ . For the safety of plant personnel working in the area of the conveyor exit, the mixture exit temperature should be lower, like  $43^\circ\text{C}$ .

(2) By giving both regions of the composite the same properties, the analytical solution for the plane wall with convection, Section 5.5, Eq. 5.43, can be used to validate the *IHT* and *FEHT* codes. Using the *IHT Models/Transient Conduction/Plane Wall* for a 9-mm thickness wall with mixture thermophysical properties, we calculated the temperatures after 50 s for three locations:  $T(0, 50s) = 91.4^\circ\text{C}$ ;  $T(6 \text{ mm}, 50s) = 63.6^\circ\text{C}$ ; and  $T(3 \text{ mm}, 50s) = 91.4^\circ\text{C}$ . The results from the *IHT* and *FEHT* codes agreed exactly.

(3) In view of the high heat removal rate on the belt lower surface, it is reasonable to assume that negligible heat loss is occurring by convection on the top surface of the mixture.

Continued ...

## PROBLEM 5.146 (Cont.)

(4) The *IHT* code representing selected FDEs, nodes 01, 02, 13 and 19, is shown below. The FDE for node 13 was derived from an energy balance, while the others are written from the *Tools* pad.

```

// Finite difference equations from Tools, Nodes 01 -12 (mixture) and 14-19 (belt)
/* Node 01: surface node (w-orientation); transient conditions; e labeled 02. */
rhom * cm * der(T01,t) = fd_1d_sur_w(T01,T02,km,qdot,deltax,Tinf01,h01,q'a01)
q'a01 = 0 // Applied heat flux, W/m^2; zero flux shown
qdot = 0
Tinf01 = 20 // Arbitrary value
h01 = 1e-6 // Causes boundary to behave as adiabatic

/* Node 02: interior node; e and w labeled 03 and 01. */
rhom*cm*der(T02,t) = fd_1d_int(T02,T03,T01,km,qdot,deltax)

/* Node 19: surface node (e-orientation); transient conditions; w labeled 18. */
rhob * cb * der(T19,t) = fd_1d_sur_e(T19,T18,kb,qdot,deltax,Tinf19,h19,q'a19)
q'a19 = 0 // Applied heat flux, W/m^2; zero flux shown
Tinf19 = 30
h19 = 3000

// Finite-difference equation from energy balance on CV, Node 13
km*(T12 - T13)/deltax + kb*(T14 - T13)/deltax = (rhom*cm + rhob*cb) *(deltax/2)*der(T13,t)

```

(5) The screen from the *FEHT* analysis is shown below. It is important to use small time steps in the integration at early times. Use the *View/Temperatures* command to find the temperature of the mixture surface at  $t_{\text{res}} = 50$  s.

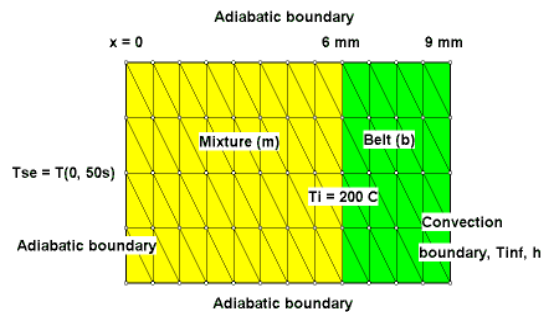

### PROBLEM 5.147

**KNOWN:** Stainless steel cylinder, 80-mm diameter by 60-mm length, initially at 600 K, suddenly quenched in an oil bath at 300 K with  $h = 500 \text{ W/m}^2 \cdot \text{K}$ . Use the ready-to-solve model in the *Examples* menu of *FEHT* to obtain the following solutions.

**FIND:** (a) Calculate the temperatures  $T(r, x, t)$  after 3 min: at the cylinder center,  $T(0, 0, 3 \text{ min})$ , at the center of a circular face,  $T(0, L, 3 \text{ min})$ , and at the midheight of the side,  $T(r_o, 0, 3 \text{ min})$ ; compare your results with those in the example; (b) Calculate and plot temperature histories at the cylinder center,  $T(0, 0, t)$ , the mid-height of the side,  $T(r_o, 0, t)$ , for  $0 \leq t \leq 10 \text{ min}$ ; use the *View/Temperature vs. Time* command; comment on the gradients and what effect they might have on phase transformations and thermal stresses; (c) Using the results for the total integration time of 10 min, use the *View/Temperature Contours* command; describe the major features of the cooling process shown in this display; create and display a 10-isotherm temperature distribution for  $t = 3 \text{ min}$ ; and (d) For the locations of part (a), calculate the temperatures after 3 min if the convection coefficient is doubled ( $h = 1000 \text{ W/m}^2 \cdot \text{K}$ ); for these two conditions, determine how long the cylinder needs to remain in the oil bath to achieve a safe-to touch surface temperature of 316 K. Tabulate and comment on the results of your analysis.

#### SCHEMATIC:

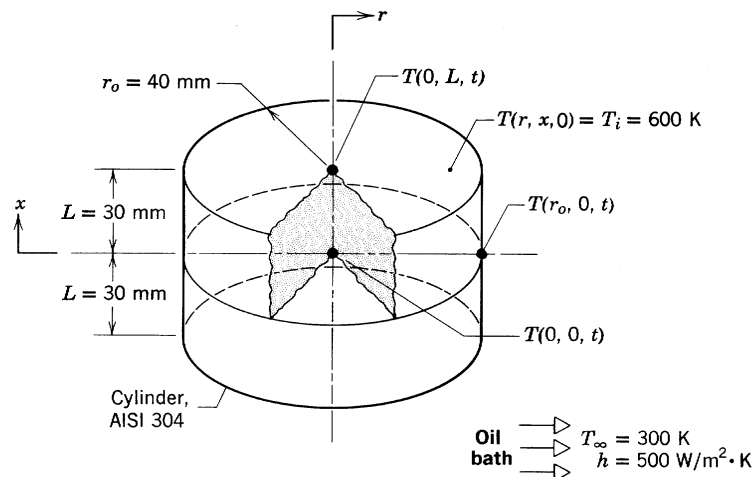

**ASSUMPTIONS:** (1) Two-dimensional conduction in  $r$ - and  $x$ -coordinates, (2) Constant properties.

**PROPERTIES:** Stainless steel:  $\rho = 7900 \text{ kg/m}^3$ ,  $c = 526 \text{ J/kg} \cdot \text{K}$ ,  $k = 17.4 \text{ W/m} \cdot \text{K}$ .

**ANALYSIS:** (a) The *FEHT ready-to-solve* model is accessed through the *Examples* menu and the annotated *Input* page is shown below. The following steps were used to obtain the solution: (1) Use the *Draw/Reduce Mesh* command three times to create the 512-element mesh; (2) In *Run*, click on *Check*, (3) In *Run*, press *Calculate* and hit *OK* to initiate the solver; and (4) Go to the *View* menu, select *Tabular Output* and read the nodal temperatures 4, 1, and 3 at  $t = t_o = 180 \text{ s}$ . The tabulated results below include those from the  $n$ -term series solution used in the *IHT* software.

Continued ...

### PROBLEM 5.147 (Cont.)

$(r, x, t_0)$	FEHT node	$T(r, x, t_0)$ (K) <i>FEHT</i>	$T(r, x, t_0)$ (K) 1-term series	$T(r, x, t_0)$ (K) n-term series
0, 0, $t_0$	4	402.7	405	402.7
0, L, $t_0$	1	368.7	372	370.5
$r_0$ , 0, $t_0$	3	362.5	365	362.4

The *FEHT* results are in excellent agreement with the *IHT* n-term series solutions for the  $x = 0$  plane nodes (4,3), except for the  $x = L$  plane node (1).

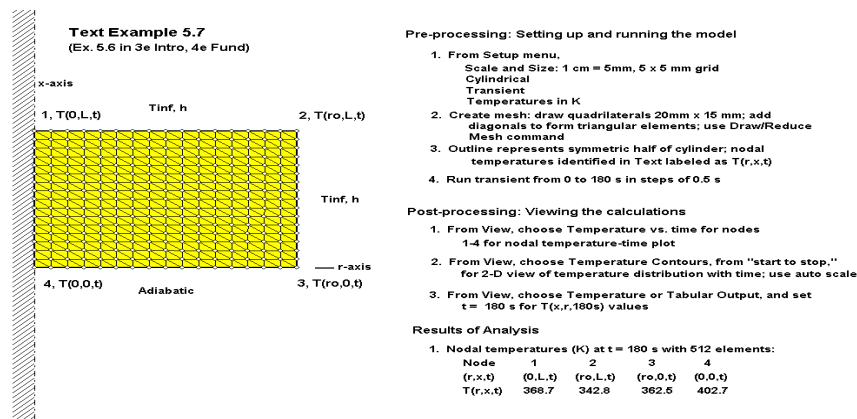

(b) Using the *View Temperature vs. Time* command, the temperature histories for nodes 4, 1, and 3 are plotted in the graph shown below. There is very small temperature difference between the locations on the surface, (node 1; 0, L) and (node 3;  $r_0$ , 0). But, the temperature difference between these surface locations and the cylinder center (node 4; 0, 0) is large at early times. Such differences wherein locations cool at considerably different rates could cause variations in microstructure and hence, mechanical properties, as well as induce thermal stresses.

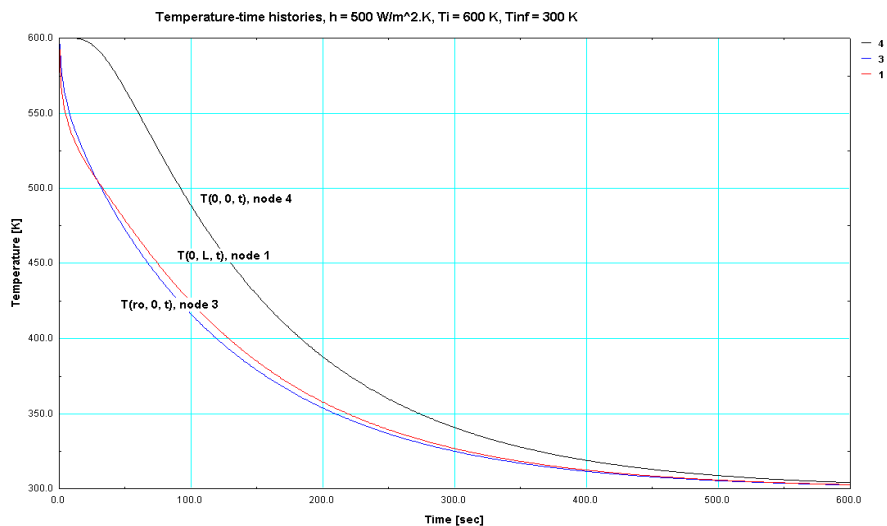

Continued ...



### PROBLEM 5.147 (Cont.)

(c) Use the *View|Temperature Contours* command with the shaded band option for the isotherm contours. Selecting the *From Start to Stop* time option, see the display of the contours as the cylinder cools during the quench process. The “movie” shows that cooling initiates at the corner  $(r_o, L, t)$  and the isotherms quickly become circular and travel toward the center  $(0, 0, t)$ . The 10-isotherm distribution for  $t = 3$  min is shown below.

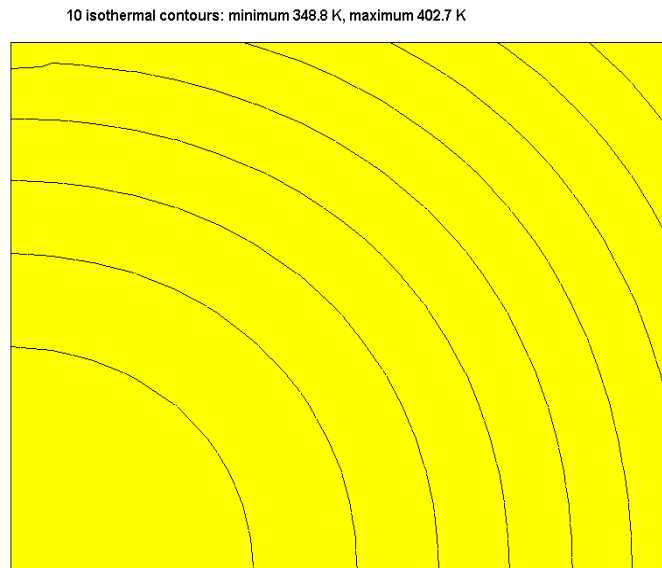

(d) Using the *FEHT* model with convection coefficients of  $500$  and  $1000 \text{ W/m}^2 \cdot \text{K}$ , the temperatures at  $t = t_o = 180$  s for the three locations of part (a) are tabulated below.

	$h = 500 \text{ W/m}^2 \cdot \text{K}$	$h = 1000 \text{ W/m}^2 \cdot \text{K}$
$T(0, 0, t_o), \text{ K}$	402.7	352.8
$T(0, L, t_o), \text{ K}$	368.7	325.8
$T(r_o, 0, t_o), \text{ K}$	362.5	322.1

Note that the effect of doubling the convection coefficient is to reduce the temperature at these locations by about  $40^\circ\text{C}$ . The time the cylinder needs to remain in the oil bath to achieve the *safe-to-touch* surface temperature of  $316 \text{ K}$  can be determined by examining the temperature history of the location (node1;  $0, L$ ). For the two convection conditions, the results are tabulated below. Doubling the coefficient reduces the cooling process time by  $40\%$ .

$T(0, L, t_o)$	$h (\text{W/m}^2 \cdot \text{K})$	$t_o (\text{s})$
316	500	370
316	1000	219

## PROBLEM 5.148

**KNOWN:** Cubic-shaped furnace, with prescribed operating temperature and convection heat transfer on the exterior surfaces.

**FIND:** Time required for the furnace to cool to a safe working temperature corresponding to an inner wall temperature of 35°C considering convection cooling on (a) the exterior surfaces and (b) on both the exterior and interior surfaces.

**SCHEMATIC:**

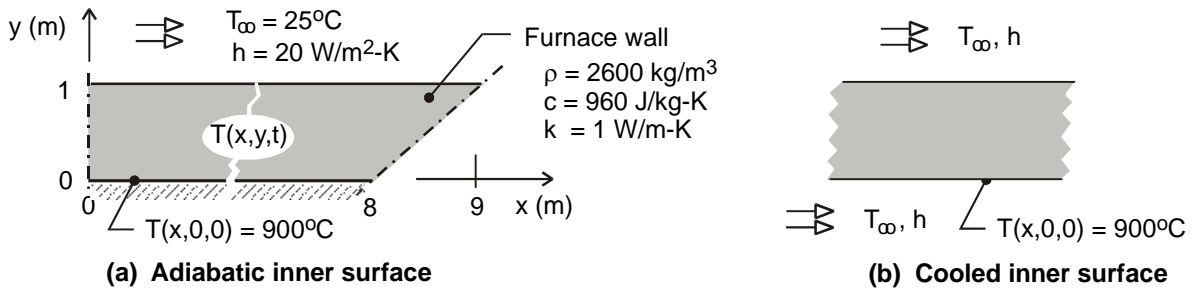

**ASSUMPTIONS:** (1) Two-dimensional conduction through the furnace walls and (2) Constant properties.

**ANALYSIS:** Assuming two-dimensional conduction through the walls and taking advantage of symmetry for the cubical shape, the analysis considers the quarter section shown in the schematic above. For part (a), with no cooling on the interior during the cool-down process, the inner surface boundary condition is adiabatic. For part (b), with cooling on both the exterior and interior, the boundary conditions are prescribed by the convection process. The boundaries through the centerline of the wall and the diagonal through the corner are symmetry planes and considered as adiabatic. We have chosen to use the finite-element software *FEHT* as the solution tool.

Using *FEHT*, an outline of the symmetrical wall section is drawn, and the material properties are specified. To determine the initial conditions for the cool-down process, we will first find the temperature distribution for steady-state operation. As such, specify the boundary condition for the inner surface as a constant temperature of 900°C; the other boundaries are as earlier described. In the *Setup* menu, click on *Steady-State*, and then *Run* to obtain the steady-state temperature distribution. This distribution represents the initial temperature distribution,  $T_i(x, y, 0)$ , for the wall at the onset of the cool-down process.

Next, in the *Setup* menu, click on *Transient*; for the nodes on the inner surface, in the *Specify / Boundary Conditions* menu, deselect the *Temperature* box (900°C) and set the *Flux* box to zero for the adiabatic condition (part (a)); and, in the *Run* command, click on *Continue* (not *Calculate*). Be sure to change the integration time scale from *seconds* to *hours*.

Because of the high ratio of wall section width (nearly 8.5 m) to the thickness (1 m), the conduction heat transfer through the section is nearly one-dimensional. We chose the x,y-section 1 m to the right of the centerline (1 m, y) as the location for examining the temperature-time history, and determining the cool-down time for the inner surface to reach the safe working temperature of 35°C.

Continued ...

**PROBLEM 5.148 (Cont.)**

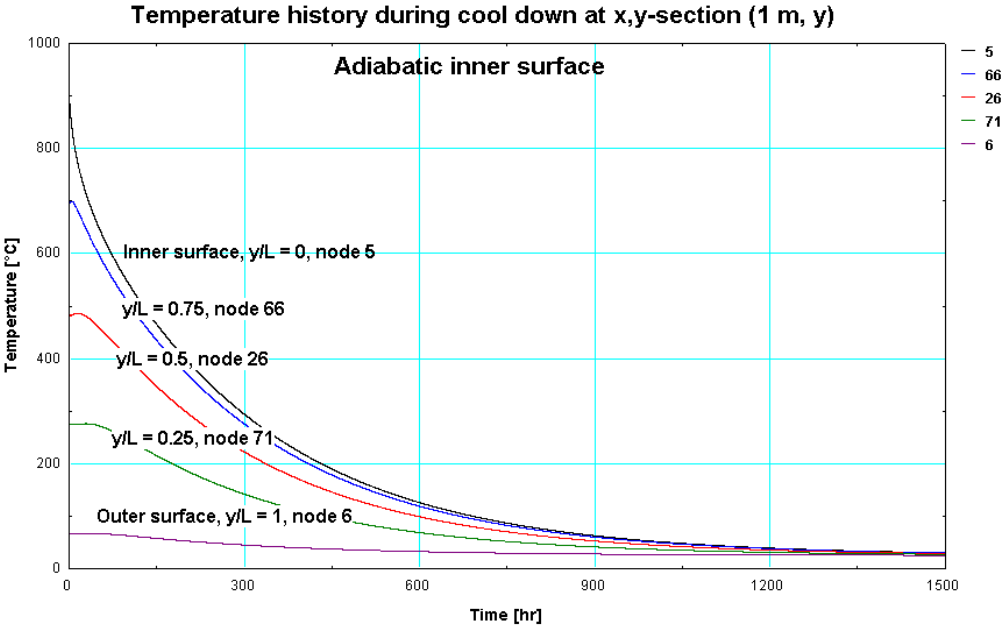

Time-to-cool, Part (a), Adiabatic inner surface. From the above temperature history, the cool-down time,  $t_a$ , corresponds to the condition when  $T_a(1\text{ m}, 0, t_a) = 35^\circ\text{C}$ . As seen from the history, this location is the last to cool. From the View / Tabular Output, find that

$$t_a = 1306\text{ h} = 54\text{ days}$$

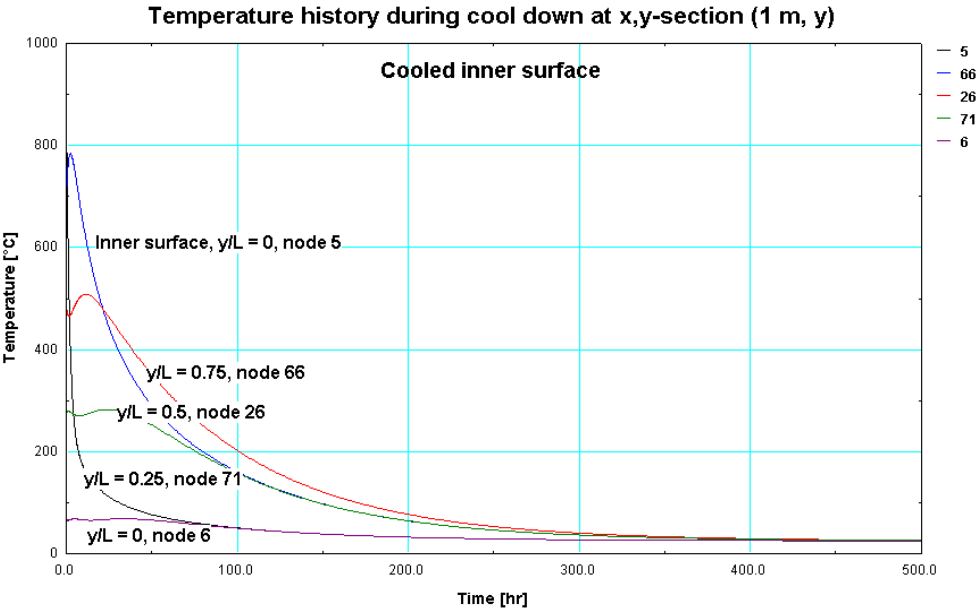

Continued ...

### PROBLEM 5.148 (Cont.)

*Time-to-cool, Part (b), Cooled inner surface.* From the above temperature history, note that the center portion of the wall, and not the inner surface, is the last to cool. The inner surface cools to 35°C in approximately 175 h or 7 days. However, if the cooling process on the inner surface were discontinued, its temperature would increase and eventually exceed the desired safe working temperature. To assure the safe condition will be met, estimate the cool down time as,  $t_b$ , corresponding to the condition when  $T_b(1 \text{ m}, 0.75 \text{ m}, t_b) = 35^\circ\text{C}$ . From the *View / Tabular Output*, find that

$$t_b = 311 \text{ h} = 13 \text{ days}$$

<

**COMMENTS:** (1) Assuming the furnace can be approximated by a two-dimensional symmetrical section greatly simplifies our analysis by not having to deal with three-dimensional corner effects. We justify this assumption on the basis that the corners represent a much shorter heat path than the straight wall section. Considering corner effects would reduce the cool-down time estimates; hence, our analysis provides a conservative estimate.

(2) For background information on the *Continue* option, see the *Run* menu in the *FEHT Help* section. Using the *Run | Calculate* command, the steady-state temperature distribution was determined for the normal operating condition of the furnace. Using the *Run | Continue* command (after clicking on *Setup / Transient*), this steady-state distribution automatically becomes the initial temperature distribution for the cool-down transient process. This feature allows for conveniently prescribing a non-uniform initial temperature distribution for a transient analysis (rather than specifying values on a node-by-node basis).

## PROBLEM 6.1

**KNOWN:** Temperature distribution at  $x_2$  in laminar thermal boundary layer.

**FIND:** (a) Whether plate is being heated or cooled, (b) Temperature distributions at two other  $x$  locations. Locations of largest and smallest heat fluxes, (c) Temperature distribution at  $x_2$  for lower and higher free stream velocities. Which velocity condition causes the largest heat flux.

**SCHEMATIC:**

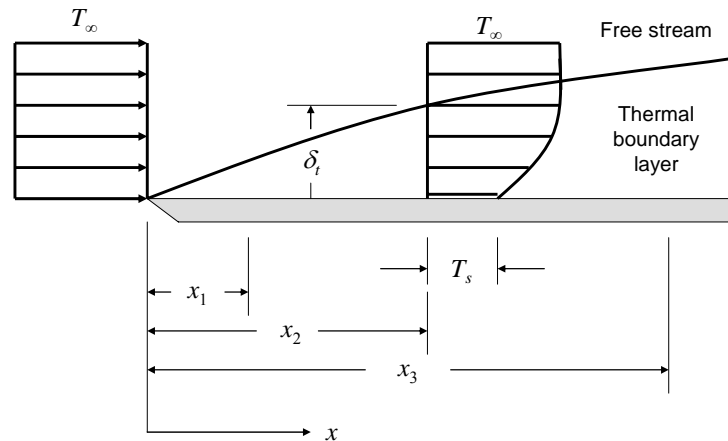

**ASSUMPTIONS:** (1) Steady-state conditions, (2) Laminar, incompressible flow.

**ANALYSIS:** (a) Since the sketch indicates that the free stream temperature is greater than the surface temperature, the plate is being heated by the fluid. This is consistent with the fact that the surface heat flux in the positive  $y$ -direction is given by Eq. 6.3:

$$q_s'' = -k_f \left. \frac{\partial T}{\partial y} \right|_{y=0}$$

From the sketch, the temperature gradient is positive, therefore the heat flux is negative. The heat transfer is in the negative  $y$ -direction, the plate is being heated by the fluid. <

(b) At every location in the boundary layer, the temperature must vary from  $T_s$  at the surface to  $T_\infty$  in the free stream. This change must occur within the thermal boundary layer thickness, as shown in the sketch below.

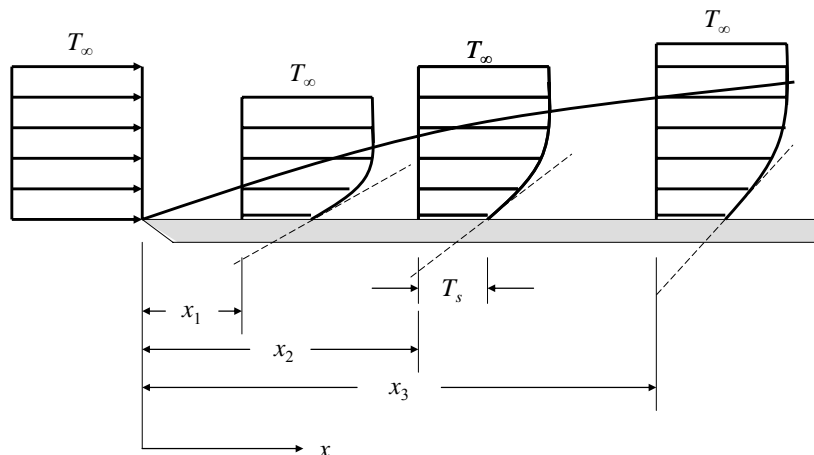

Continued...

### PROBLEM 6.1 (Cont.)

The magnitude of the heat flux is proportional to the temperature gradient at the surface,  $\partial T / \partial y|_{y=0}$ , which is shown schematically as a dashed line. The temperature gradient is steeper (larger) at  $x_1$  where the thermal boundary layer is thinner and less steep (smaller) at  $x_3$  where the thermal boundary layer is thicker. Therefore, the magnitude of the local heat flux is largest at  $x_1$  and smallest at  $x_3$ . <

(c) As the free stream velocity increases the boundary layer becomes thinner. Sketches for a low and high free stream velocity are shown below.

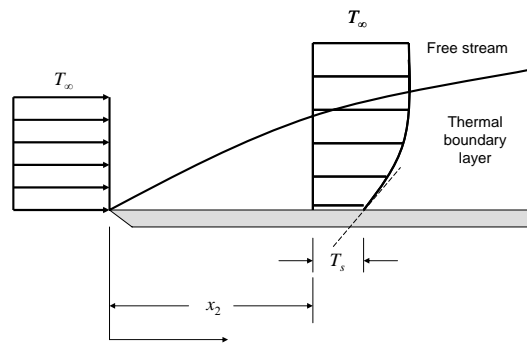

Low freestream velocity case.

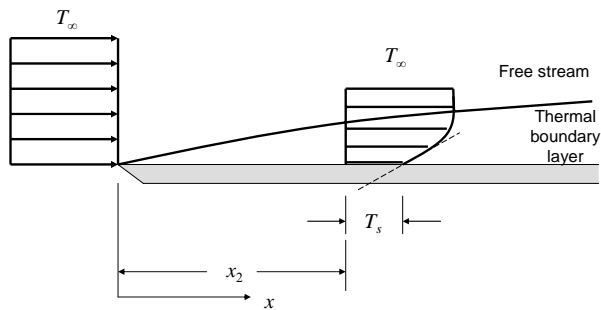

High freestream velocity case.

The temperature gradient, shown as the dashed line, is steeper for the higher free stream velocity case. Therefore the higher free stream velocity case has the higher convective heat flux. <

**COMMENTS:** It is important to understand how the temperature gradient at the surface varies as the thickness of the boundary layer changes.

## PROBLEM 6.2

**KNOWN:** Form of the velocity and temperature profiles for flow over a surface.

**FIND:** Expressions for the friction and convection coefficients.

**SCHEMATIC:**

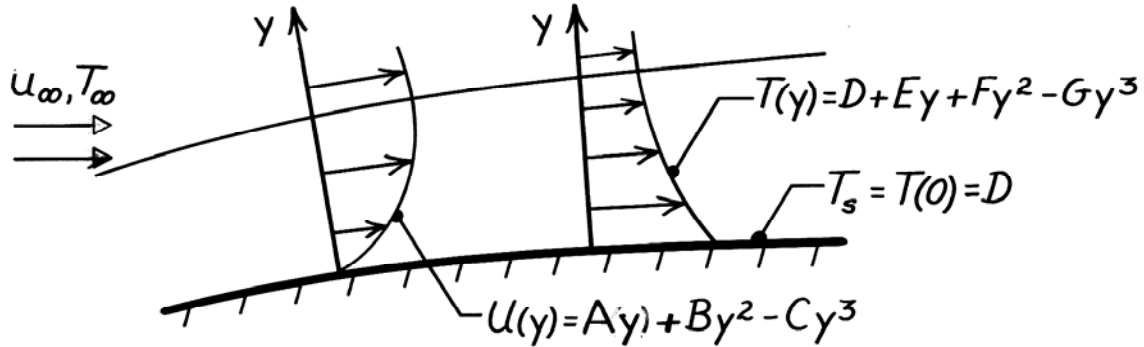

**ANALYSIS:** The shear stress at the wall is

$$\tau_s = \mu \left. \frac{\partial u}{\partial y} \right|_{y=0} = \mu \left[ A + 2By - 3Cy^2 \right]_{y=0} = A\mu.$$

Hence, the friction coefficient has the form,

$$C_f = \frac{\tau_s}{\rho u_\infty^2 / 2} = \frac{2A\mu}{\rho u_\infty^2}$$

$$C_f = \frac{2A\nu}{u_\infty^2}.$$

<

The convection coefficient is

$$h = \frac{-k_f (\partial T / \partial y)_{y=0}}{T_s - T_\infty} = \frac{-k_f [E + 2Fy - 3Gy^2]_{y=0}}{D - T_\infty}$$

$$h = \frac{-k_f E}{D - T_\infty}.$$

<

**COMMENTS:** It is a simple matter to obtain the important surface parameters from knowledge of the corresponding boundary layer profiles. However, it is rarely a simple matter to determine the form of the profile.

### PROBLEM 6.3

**KNOWN:** Boundary layer temperature distribution.

**FIND:** Surface heat flux.

**SCHEMATIC:**

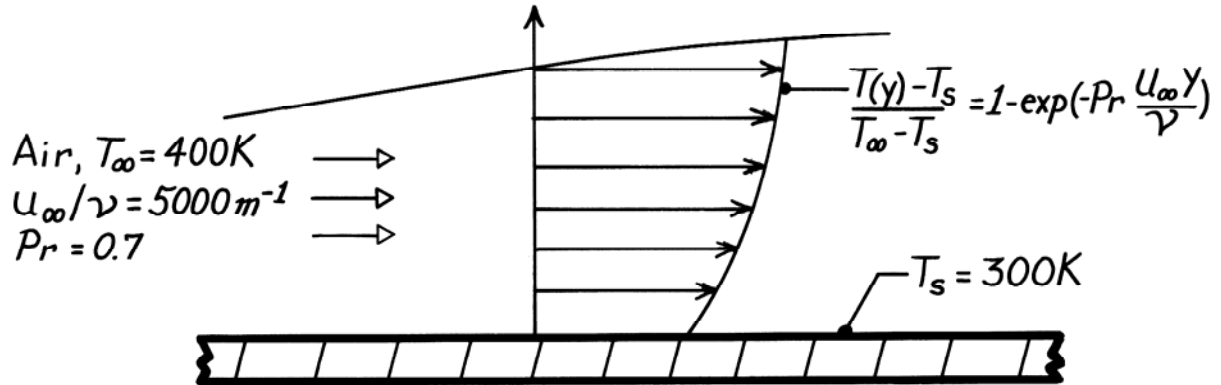

**PROPERTIES:** Table A-4, Air ( $T_s = 300\text{K}$ ):  $k = 0.0263\text{ W/m}\cdot\text{K}$ .

**ANALYSIS:** Applying Fourier's law at  $y = 0$ , the heat flux is

$$q_s'' = -k \left. \frac{\partial T}{\partial y} \right|_{y=0} = -k(T_\infty - T_s) \left[ Pr \frac{U_\infty}{\nu} \right] \exp\left[ -Pr \frac{U_\infty y}{\nu} \right] \Big|_{y=0}$$

$$q_s'' = -k(T_\infty - T_s) Pr \frac{U_\infty}{\nu}$$

$$q_s'' = -0.0263\text{ W/m}\cdot\text{K} (100\text{K}) 0.7 \times 5000\text{ 1/m}$$

$$q_s'' = -9205\text{ W/m}^2$$

<

**COMMENTS:** (1) Negative flux implies convection heat transfer to the surface.

(2) Note use of  $k$  at  $T_s$  to evaluate  $q_s''$  from Fourier's law.



### PROBLEM 6.4

**KNOWN:** Surface temperatures of a steel wall and temperature of water flowing over the wall.

**FIND:** (a) Convection coefficient, (b) Temperature gradient in wall and in water at wall surface.

**SCHEMATIC:**

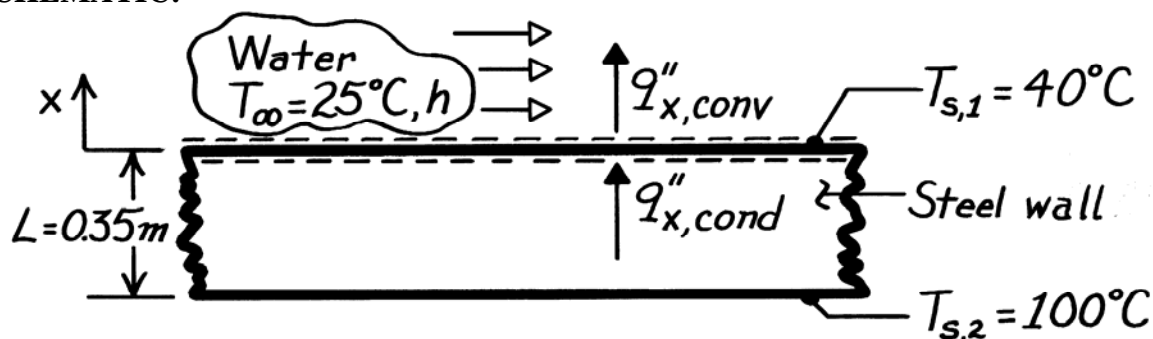

**ASSUMPTIONS:** (1) Steady-state conditions, (2) One-dimensional heat transfer in  $x$ , (3) Constant properties.

**PROPERTIES:** Table A-1, Steel Type AISI 1010 ( $70^\circ\text{C} = 343\text{K}$ ),  $k_s = 61.7 \text{ W/m}\cdot\text{K}$ ; Table A-6, Water ( $32.5^\circ\text{C} = 305\text{K}$ ),  $k_f = 0.62 \text{ W/m}\cdot\text{K}$ .

**ANALYSIS:** (a) Applying an energy balance to the control surface at  $x = 0$ , it follows that

$$q''_{x,\text{cond}} - q''_{x,\text{conv}} = 0$$

and using the appropriate rate equations,

$$k_s \frac{T_{s,2} - T_{s,1}}{L} = h(T_{s,1} - T_\infty).$$

Hence,

$$h = \frac{k_s}{L} \frac{T_{s,2} - T_{s,1}}{T_{s,1} - T_\infty} = \frac{61.7 \text{ W/m}\cdot\text{K}}{0.35\text{m}} \frac{60^\circ\text{C}}{15^\circ\text{C}} = 705 \text{ W/m}^2 \cdot \text{K}. \quad <$$

(b) The gradient in the wall at the surface is

$$\left(\frac{dT}{dx}\right)_s = -\frac{T_{s,2} - T_{s,1}}{L} = -\frac{60^\circ\text{C}}{0.35\text{m}} = -171.4^\circ\text{C/m}.$$

In the water at  $x = 0$ , the definition of  $h$  gives

$$\left(\frac{dT}{dx}\right)_{f,x=0} = -\frac{h}{k_f} (T_{s,1} - T_\infty)$$

$$\left(\frac{dT}{dx}\right)_{f,x=0} = -\frac{705 \text{ W/m}^2 \cdot \text{K}}{0.62 \text{ W/m}\cdot\text{K}} (15^\circ\text{C}) = -17,056^\circ\text{C/m}. \quad <$$

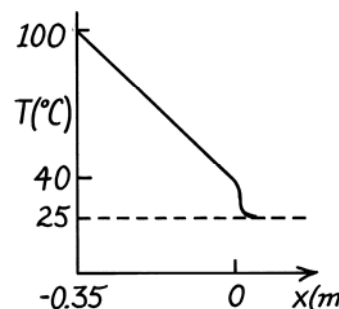

**COMMENTS:** Note the relative magnitudes of the gradients. Why is there such a large difference?

### PROBLEM 6.5

**KNOWN:** Variation of  $h_x$  with  $x$  for laminar flow over a flat plate.

**FIND:** Ratio of average coefficient,  $\bar{h}_x$ , to local coefficient,  $h_x$ , at  $x$ .

**SCHEMATIC:**

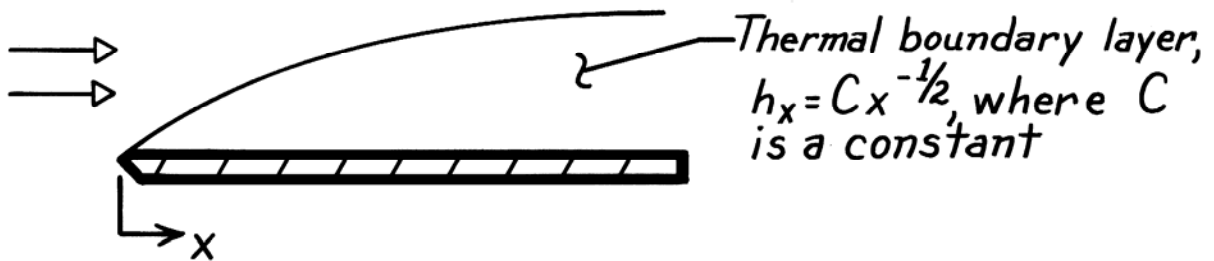

**ANALYSIS:** The average value of  $h_x$  between 0 and  $x$  is

$$\begin{aligned}\bar{h}_x &= \frac{1}{x} \int_0^x h_x dx = \frac{C}{x} \int_0^x x^{-1/2} dx \\ \bar{h}_x &= \frac{C}{x} 2x^{1/2} = 2Cx^{-1/2} \\ \bar{h}_x &= 2h_x.\end{aligned}$$

Hence,  $\frac{\bar{h}_x}{h_x} = 2.$

<

**COMMENTS:** Both the local and average coefficients decrease with increasing distance  $x$  from the leading edge, as shown in the sketch below.

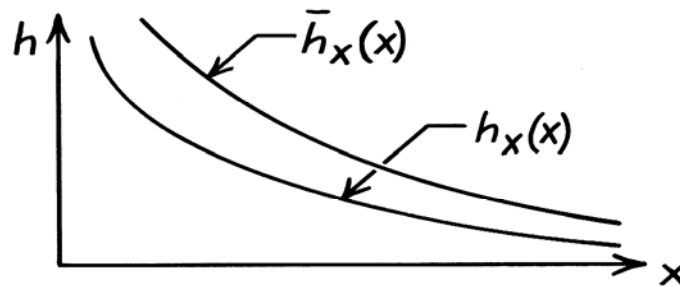

## PROBLEM 6.6

**KNOWN:** Variation of local heat transfer coefficient with  $x$ . Length of plate.

**FIND:** Ratio of heat transfer coefficients for flow oriented in short and long directions.

**SCHEMATIC:**

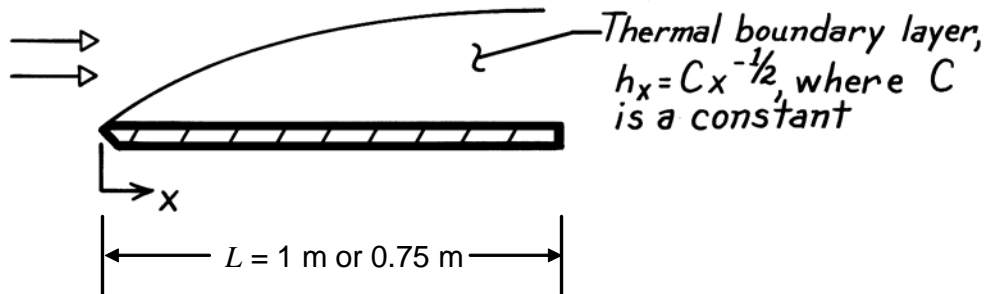

**ASSUMPTIONS:** (1) Steady-state conditions, (2) Laminar flow, (3) Incompressible flow.

**ANALYSIS:** The local heat transfer coefficient varies with  $x$  according to

$$h_x = Cx^{-1/2}$$

The average heat transfer coefficient over the entire plate is given by Eq. 6.14:

$$\bar{h}_L = \frac{1}{L} \int_0^L h_x dx = \frac{1}{L} \int_0^L Cx^{-1/2} dx = 2CL^{-1/2}$$

Therefore the ratio of average heat transfer coefficients for the two different flow orientations is

$$\frac{\bar{h}_{L,1}}{\bar{h}_{L,2}} = \left( \frac{L_2}{L_1} \right)^{1/2}$$

The average heat transfer coefficient is larger when the flow is oriented in the short direction because local heat transfer coefficients are largest near the leading edge. Therefore the heat transfer rate will be larger when flow is oriented in the short direction. <

**COMMENTS:** Many engineering devices that are affected by, or utilize convection heat transfer in their operation incorporate short sections of surfaces in order to take advantage of the high local heat transfer coefficients that exist near the leading edges of such surfaces.

### PROBLEM 6.7

**KNOWN:** Distribution of local convection coefficient for obstructed parallel flow over a flat plate.

**FIND:** Average heat transfer coefficient and ratio of average to local at the trailing edge.

**SCHEMATIC:**

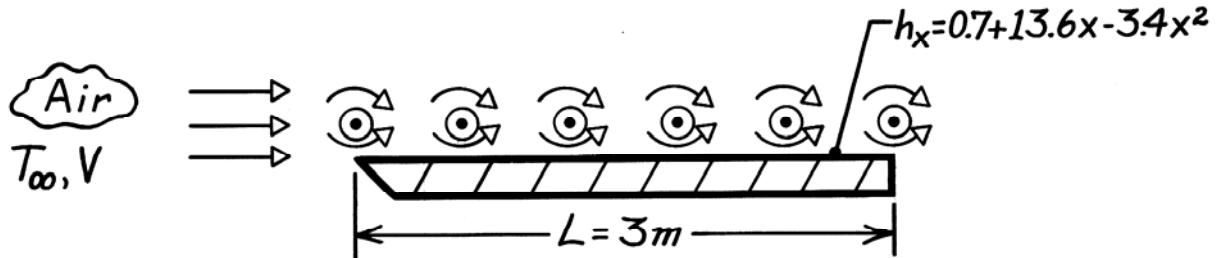

**ANALYSIS:** The average convection coefficient is

$$\bar{h}_L = \frac{1}{L} \int_0^L h_x dx = \frac{1}{L} \int_0^L (0.7 + 13.6x - 3.4x^2) dx$$
$$\bar{h}_L = \frac{1}{L} (0.7L + 6.8L^2 - 1.13L^3) = 0.7 + 6.8L - 1.13L^2$$

$$\bar{h}_L = 0.7 + 6.8(3) - 1.13(9) = 10.9 \text{ W/m}^2 \cdot \text{K}. \quad <$$

The local coefficient at  $x = 3\text{ m}$  is

$$h_L = 0.7 + 13.6(3) - 3.4(9) = 10.9 \text{ W/m}^2 \cdot \text{K}.$$

Hence,

$$\bar{h}_L / h_L = 1.0. \quad <$$

**COMMENTS:** The result  $\bar{h}_L / h_L = 1.0$  is unique to  $x = 3\text{ m}$  and is a consequence of the existence of a maximum for  $h_x(x)$ . The maximum occurs at  $x = 2\text{ m}$ , where

$$(dh_x / dx) = 0 \text{ and } (d^2h_x / dx^2 < 0.)$$

### PROBLEM 6.8

**KNOWN:** Variation of local convection coefficient with  $x$  for free convection from a vertical heated plate.

**FIND:** Ratio of average to local convection coefficient.

**SCHEMATIC:**

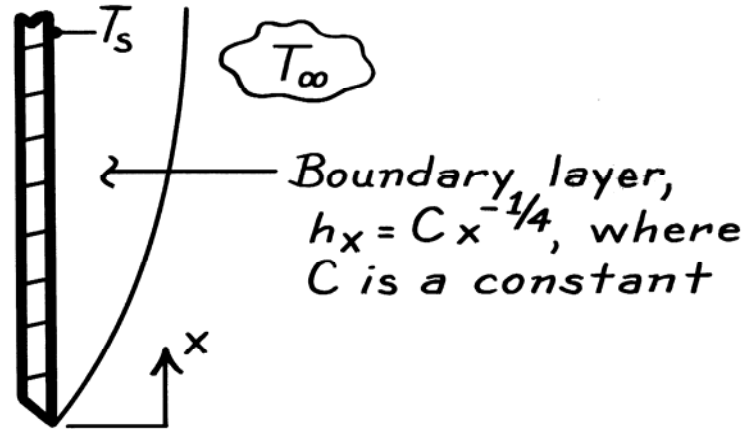

**ANALYSIS:** The average coefficient from 0 to  $x$  is

$$\bar{h}_x = \frac{1}{x} \int_0^x h_x dx = \frac{C}{x} \int_0^x x^{-1/4} dx$$

$$\bar{h}_x = \frac{4}{3} \frac{C}{x} x^{3/4} = \frac{4}{3} C x^{-1/4} = \frac{4}{3} h_x.$$

Hence, 
$$\frac{\bar{h}_x}{h_x} = \frac{4}{3}.$$

The variations with distance of the local and average convection coefficients are shown in the sketch.

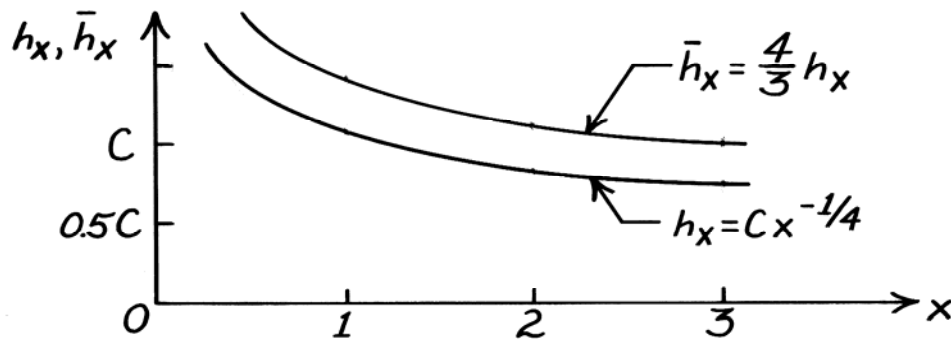

**COMMENTS:** Note that  $\bar{h}_x / h_x = 4/3$  is independent of  $x$ . Hence the average coefficient for an entire plate of length  $L$  is  $\bar{h}_L = \frac{4}{3} h_L$ , where  $h_L$  is the local coefficient at  $x = L$ . Note also that the average *exceeds* the local. Why?

## PROBLEM 6.9

**KNOWN:** Expression for the local heat transfer coefficient of a circular, hot gas jet at  $T_\infty$  directed normal to a circular plate at  $T_s$  of radius  $r_o$ .

**FIND:** Heat transfer rate to the plate by convection.

**SCHEMATIC:**

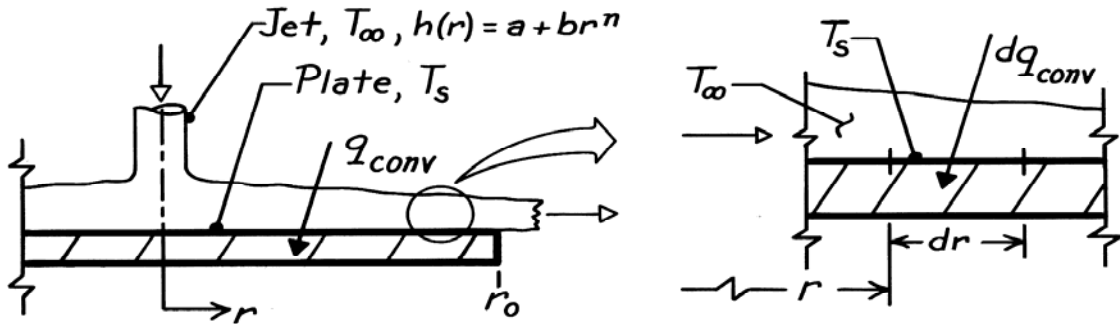

**ASSUMPTIONS:** (1) Steady-state conditions, (2) Flow is axisymmetric about the plate, (3) For  $h(r)$ ,  $a$  and  $b$  are constants and  $n \neq -2$ .

**ANALYSIS:** The convective heat transfer rate to the plate follows from Newton's law of cooling

$$q_{\text{conv}} = \int_A dq_{\text{conv}} = \int_A h(r) \cdot dA \cdot (T_\infty - T_s).$$

The local heat transfer coefficient is known to have the form,

$$h(r) = a + br^n$$

and the differential area on the plate surface is

$$dA = 2\pi r dr.$$

Hence, the heat rate is

$$\begin{aligned} q_{\text{conv}} &= \int_0^{r_o} (a + br^n) \cdot 2\pi r dr \cdot (T_\infty - T_s) \\ q_{\text{conv}} &= 2\pi (T_\infty - T_s) \left[ \frac{a}{2} r^2 + \frac{b}{n+2} r^{n+2} \right]_0^{r_o} \\ q_{\text{conv}} &= 2\pi \left[ \frac{a}{2} r_o^2 + \frac{b}{n+2} r_o^{n+2} \right] (T_\infty - T_s). \end{aligned}$$

<

**COMMENTS:** Note the importance of the requirement,  $n \neq -2$ . Typically, the radius of the jet is much smaller than that of the plate.

## PROBLEM 6.10

**KNOWN:** Expression for face-averaged Nusselt numbers on a cylinder of rectangular cross section. Dimensions of the cylinder.

**FIND:** Average heat transfer coefficient over the entire cylinder. Plausible explanation for variations in the face-averaged heat transfer coefficients.

**SCHEMATIC:**

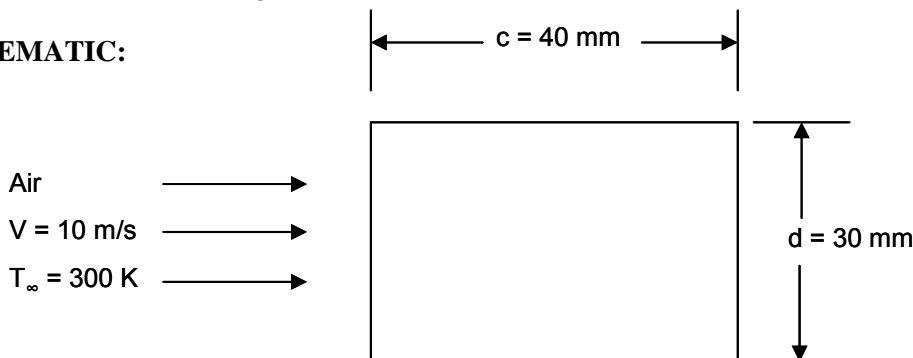

**ASSUMPTIONS:** (1) Steady-state conditions, (2) Constant properties.

**PROPERTIES:** Table A.4, air (300 K):  $k = 0.0263 \text{ W/m}\cdot\text{K}$ ,  $\nu = 1.589 \times 10^{-5} \text{ m}^2/\text{s}$ ,  $\text{Pr} = 0.707$ .

**ANALYSIS:**

For the square cylinder,  $c/d = 40 \text{ mm}/30 \text{ mm} = 1.33$

$$\text{Re}_d = \frac{Vd}{\nu} = \frac{10 \text{ m/s} \times 30 \times 10^{-3} \text{ m}}{1.589 \times 10^{-5} \text{ m}^2/\text{s}} = 18,880$$

Therefore, for the front face  $C = 0.674$ ,  $m = 1/2$ . For the sides,  $C = 0.107$ ,  $m = 2/3$  while for the back  $C = 0.153$ ,  $m = 2/3$ .

Front face:

$$\text{Nu}_{d,f} = 0.674 \times 18,880^{1/2} \times 0.707^{1/3} = 82.44$$

$$\bar{h}_f = \frac{k\text{Nu}_d}{d} = \frac{0.0263 \text{ W/m}\cdot\text{K} \times 82.44}{30 \times 10^{-3} \text{ m}} = 72.27 \text{ W/m}^2 \cdot \text{K}$$

Side faces:

$$\text{Nu}_{d,s} = 0.107 \times 18,880^{2/3} \times 0.707^{1/3} = 67.36$$

$$\bar{h}_s = \frac{k\text{Nu}_{d,s}}{d} = \frac{0.0263 \text{ W/m}\cdot\text{K} \times 67.36}{30 \times 10^{-3} \text{ m}} = 59.05 \text{ W/m}^2 \cdot \text{K}$$

Back face:

$$\text{Nu}_{d,b} = 0.153 \times 18,880^{2/3} \times 0.707^{1/3} = 96.43$$

$$\bar{h}_b = \frac{k\text{Nu}_{d,b}}{d} = \frac{0.0263 \text{ W/m}\cdot\text{K} \times 96.43}{30 \times 10^{-3} \text{ m}} = 84.54 \text{ W/m}^2 \cdot \text{K}$$

Continued...

### PROBLEM 6.10 (Cont.)

For the entire square cylinder of unit length,

$$\bar{h} = \frac{\bar{h}_f A_f + 2\bar{h}_s A_s + \bar{h}_b A_b}{A_f + 2A_s + A_b}$$
$$\bar{h} = \frac{\left( 72.27 \text{ W/m}^2 \cdot \text{K} \times 30 \times 10^{-3} \text{ m} + 2 \times 59.05 \text{ W/m}^2 \cdot \text{K} \times 40 \times 10^{-3} \text{ m} \right) + 84.54 \text{ W/m}^2 \cdot \text{K} \times 30 \times 10^{-3} \text{ m}}{(2 \times 30 \times 10^{-3} \text{ m} + 2 \times 40 \times 10^{-3} \text{ m})}$$

$$\bar{h} = 67.35 \text{ W/m}^2 \cdot \text{K}$$

<

The face-averaged heat transfer coefficients are largest on the back face and smallest on the side faces. Plausible explanations for the variations of the face-averaged heat transfer coefficients are complex fluid flow patterns including vortex shedding on the back face and development of relatively thick boundary layers along the sides.

**COMMENT:** See S.Y. Yoo, J.H. Park, C.H. Chung and M.K. Chung, Journal of Heat Transfer, Vol. 125, pp. 1163-1169, 2003 for details.



## PROBLEM 6.11

**KNOWN:** Variation of local heat transfer coefficient around a circular collector tube.

**FIND:** (a) Estimate the average heat transfer coefficient, (b) Case with highest collector efficiency.

**SCHEMATIC:**

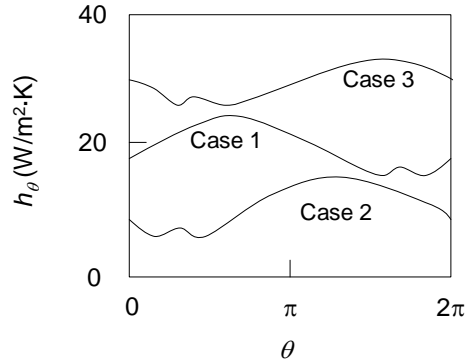

**ASSUMPTIONS:** Solar irradiation is independent of the reflector orientation.

**ANALYSIS:** (a) From Eq. 6.13,

$$\bar{h} = \frac{1}{A_s} \int_{A_s} h dA_s = \frac{1}{\pi DL} \int_{\theta=0}^{2\pi} h_{\theta} (D/2) L d\theta = \frac{1}{2\pi} \int_{\theta=0}^{2\pi} h_{\theta} d\theta$$

where  $L$  is the collector tube length. Hence, the average heat transfer coefficient may be estimated as the average value of the local heat transfer coefficient. Approximate values of the average heat transfer coefficient are shown in the sketch below.

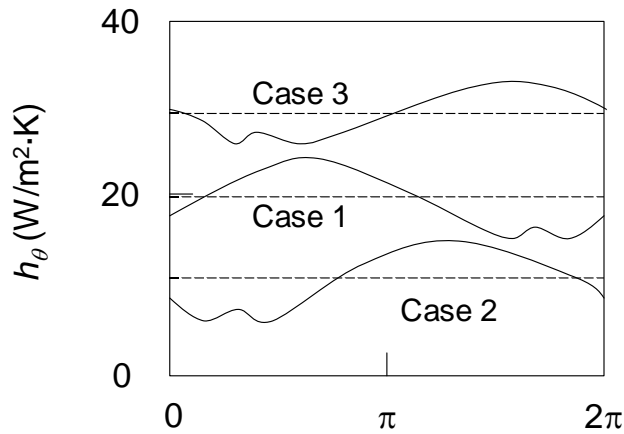

For Case 1,  $\bar{h} \approx 20 \text{ W/m}^2\cdot\text{K}$ ; for Case 2,  $\bar{h} \approx 10 \text{ W/m}^2\cdot\text{K}$ , for Case 3,  $\bar{h} \approx 30 \text{ W/m}^2\cdot\text{K}$  <

(b) The collector tube will be hotter than the ambient air. Hence, convective losses from the collector tube will diminish the overall collector efficiency. Therefore, Case 2 will have the highest collector efficiency. <

**COMMENTS:** (1) For case 2, the parabolic reflector partially “shields” the collector tube from the wind, resulting in reduced heat transfer coefficients. The flow adjacent to the tube also experiences a change in direction for case 2, with a large recirculation pattern established behind the reflector. (2) None of the cases experiences symmetrical flow over the collector tube, as would be expected without the reflector in place. (3) See Naeni and Yaghoubi, “Analysis of Wind Flow Around a Parabolic Collector (2) Heat Transfer from Receiver Tube,” *Renewable Energy*, Vol. 32, pp. 1259 – 1272, 2007, for additional discussion.

## PROBLEM 6.12

**KNOWN:** Temperature distribution in boundary layer for air flow over a flat plate.

**FIND:** Variation of local convection coefficient along the plate and value of average coefficient.

**SCHEMATIC:**

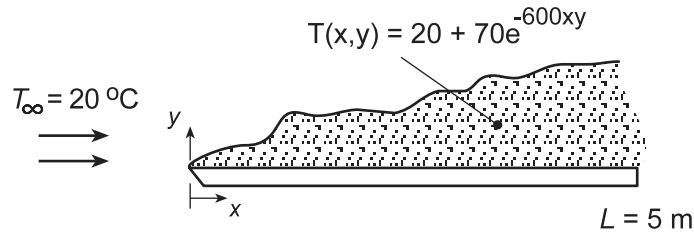

**ANALYSIS:** From Eq. 6.5,

$$h = -\frac{k \partial T / \partial y|_{y=0}}{(T_s - T_\infty)} = +\frac{k(70 \times 600x)}{(T_s - T_\infty)}$$

where  $T_s = T(x, 0) = 90^\circ\text{C}$ . Evaluating  $k$  at the arithmetic mean of the freestream and surface temperatures,  $\bar{T} = (20 + 90)^\circ\text{C}/2 = 55^\circ\text{C} = 328\text{ K}$ , Table A.4 yields  $k = 0.0284\text{ W/m}\cdot\text{K}$ . Hence, with  $T_s - T_\infty = 70^\circ\text{C} = 70\text{ K}$ ,

$$h = \frac{0.0284\text{ W/m}\cdot\text{K}(42,000x)\text{ K/m}}{70\text{ K}} = 17x \left( \text{W/m}^2\cdot\text{K} \right) \quad <$$

and the convection coefficient increases linearly with  $x$ .

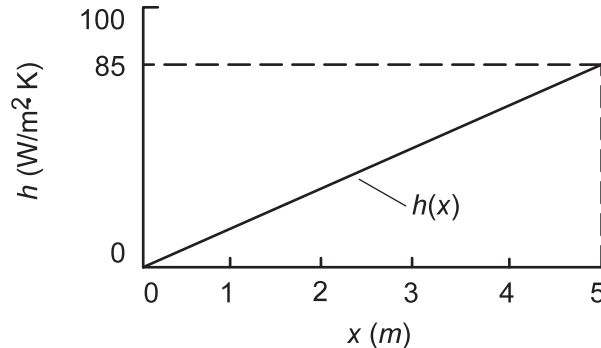

The average coefficient over the range  $0 \leq x \leq 5\text{ m}$  is

$$\bar{h} = \frac{1}{L} \int_0^L h dx = \frac{17}{5} \int_0^5 x dx = \frac{17}{5} \frac{x^2}{2} \Big|_0^5 = 42.5\text{ W/m}^2\cdot\text{K} \quad <$$

### PROBLEM 6.13

**KNOWN:** Variation of local convection coefficient with distance  $x$  from a heated plate with a uniform temperature  $T_s$ .

**FIND:** (a) An expression for the average coefficient  $\bar{h}_{12}$  for the section of length  $(x_2 - x_1)$  in terms of  $C$ ,  $x_1$  and  $x_2$ , and (b) An expression for  $\bar{h}_{12}$  in terms of  $x_1$  and  $x_2$ , and the average coefficients  $\bar{h}_1$  and  $\bar{h}_2$ , corresponding to lengths  $x_1$  and  $x_2$ , respectively.

**SCHEMATIC:**

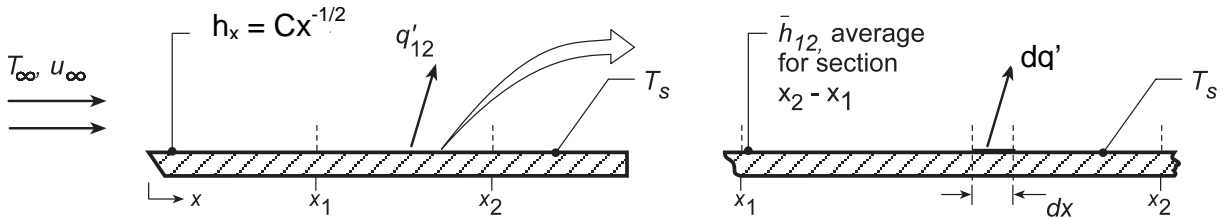

**ASSUMPTIONS:** (1) Laminar flow over a plate with uniform surface temperature,  $T_s$ , and (2) Spatial variation of local coefficient is of the form  $h_x = Cx^{-1/2}$ , where  $C$  is a constant.

**ANALYSIS:** (a) The heat transfer rate per unit width from a longitudinal section,  $x_2 - x_1$ , can be expressed as

$$q'_{12} = \bar{h}_{12} (x_2 - x_1) (T_s - T_\infty) \quad (1)$$

where  $\bar{h}_{12}$  is the average coefficient for the section of length  $(x_2 - x_1)$ . The heat rate can also be written in terms of the local coefficient, Eq. (6.11), as

$$q'_{12} = \int_{x_1}^{x_2} h_x dx (T_s - T_\infty) = (T_s - T_\infty) \int_{x_1}^{x_2} h_x dx \quad (2)$$

Combining Eq. (1) and (2),

$$\bar{h}_{12} = \frac{1}{(x_2 - x_1)} \int_{x_1}^{x_2} h_x dx \quad (3)$$

and substituting for the form of the local coefficient,  $h_x = Cx^{-1/2}$ , find that

$$\bar{h}_{12} = \frac{1}{(x_2 - x_1)} \int_{x_1}^{x_2} Cx^{-1/2} dx = \frac{C}{x_2 - x_1} \left[ \frac{x^{1/2}}{1/2} \right]_{x_1}^{x_2} = 2C \frac{x_2^{1/2} - x_1^{1/2}}{x_2 - x_1} \quad (4)$$

(b) The heat rate, given as Eq. (1), can also be expressed as

$$q'_{12} = \bar{h}_2 x_2 (T_s - T_\infty) - \bar{h}_1 x_1 (T_s - T_\infty) \quad (5)$$

which is the difference between the heat rate for the plate over the section  $(0 - x_2)$  and over the section  $(0 - x_1)$ . Combining Eqs. (1) and (5), find,

$$\bar{h}_{12} = \frac{\bar{h}_2 x_2 - \bar{h}_1 x_1}{x_2 - x_1} \quad (6)$$

**COMMENTS:** (1) Note that, from Eq. 6.6,

$$\bar{h}_x = \frac{1}{x} \int_0^x h_x dx = \frac{1}{x} \int_0^x Cx^{-1/2} dx = 2Cx^{-1/2} \quad (7)$$

or  $\bar{h}_x = 2h_x$ . Substituting Eq. (7) into Eq. (6), see that the result is the same as Eq. (4).

### PROBLEM 6.14

**KNOWN:** Radial distribution of local convection coefficient for flow normal to a circular disk.

**FIND:** Expression for average Nusselt number.

**SCHEMATIC:**

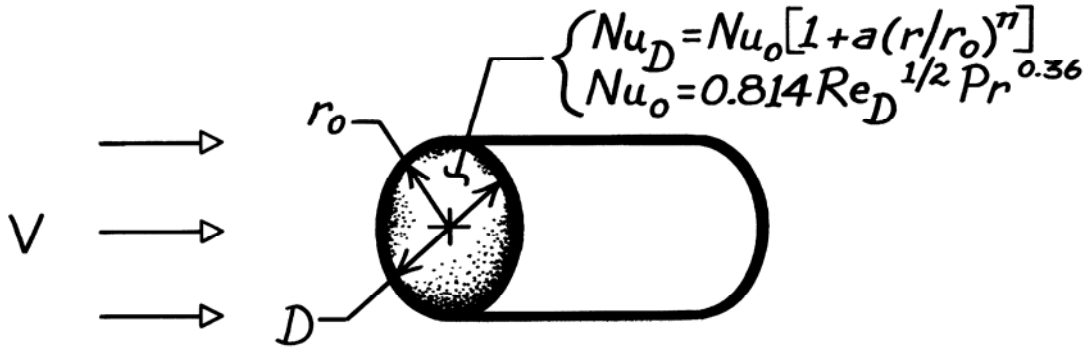

**ASSUMPTIONS:** Constant properties.

**ANALYSIS:** The average convection coefficient is

$$\begin{aligned}\bar{h} &= \frac{1}{A_s} \int_{A_s} h dA_s \\ \bar{h} &= \frac{1}{\pi r_o^2} \int_0^{r_o} \frac{k}{D} \text{Nu}_o \left[ 1 + a \left( \frac{r}{r_o} \right)^n \right] 2\pi r dr \\ \bar{h} &= \frac{k \text{Nu}_o}{r_o^3} \left[ \frac{r^2}{2} + \frac{a r^{n+2}}{(n+2)r_o^n} \right]_0^{r_o}\end{aligned}$$

where  $\text{Nu}_o$  is the Nusselt number at the stagnation point ( $r = 0$ ). Hence,

$$\begin{aligned}\overline{\text{Nu}}_D &= \frac{\bar{h}D}{k} = 2\text{Nu}_o \left[ \frac{(r/r_o)^2}{2} + \frac{a}{(n+2)} \left( \frac{r}{r_o} \right)^{n+2} \right]_0^{r_o} \\ \overline{\text{Nu}}_D &= \text{Nu}_o \left[ 1 + \frac{2a}{(n+2)} \right] \\ \overline{\text{Nu}}_D &= \left[ 1 + \frac{2a}{(n+2)} \right] 0.814 \text{Re}_D^{1/2} \text{Pr}^{0.36}.\end{aligned}$$

**COMMENTS:** The increase in  $h(r)$  with  $r$  may be explained in terms of the sharp turn which the boundary layer flow must make around the edge of the disk. The boundary layer accelerates and its thickness decreases as it makes the turn, causing the local convection coefficient to increase.

## PROBLEM 6.15

**KNOWN:** Convection correlation and temperature of an impinging air jet. Dimensions and initial temperature of a heated copper disk. Properties of the air and copper.

**FIND:** Effect of jet velocity on temperature decay of disk following jet impingement.

**SCHEMATIC:**

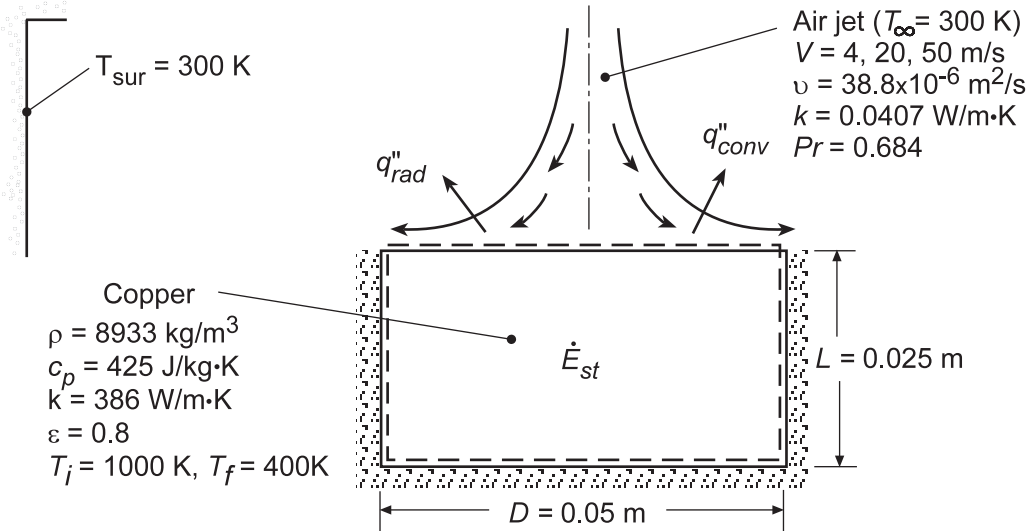

**ASSUMPTIONS:** (1) Validity of lumped capacitance analysis, (2) Negligible heat transfer from sides and bottom of disk, (3) Constant properties.

**ANALYSIS:** Performing an energy balance on the disk, it follows that

$\dot{E}_{st} = \rho V c \, dT/dt = -A_s (q''_{conv} + q''_{rad})$ . Hence, with  $V = A_s L$ ,

$$\frac{dT}{dt} = - \frac{\bar{h}(T - T_{\infty}) + h_r(T - T_{sur})}{\rho c L}$$

where,  $h_r = \epsilon \sigma (T + T_{sur})(T^2 + T_{sur}^2)$  and, from the solution to Problem 6.14,

$$\bar{h} = \frac{k}{D} \overline{Nu}_D = \frac{k}{D} \left( 1 + \frac{2a}{n+2} \right) 0.814 Re_D^{1/2} Pr^{0.36}$$

With  $a = 0.30$  and  $n = 2$ , it follows that

$$\bar{h} = (k/D) 0.936 Re_D^{1/2} Pr^{0.36}$$

where  $Re_D = VD/\nu$ . Using the *Lumped Capacitance Model* of IHT, the following temperature histories were determined.

Continued ...

### PROBLEM 6.15 (Cont.)

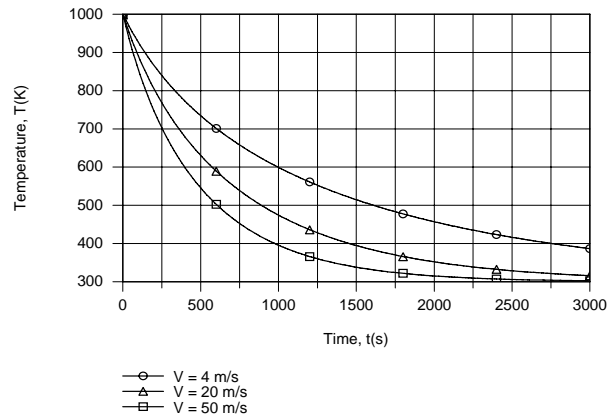

The temperature decay becomes more pronounced with increasing  $V$ , and a final temperature of 400 K is reached at  $t = 2760$ , 1455 and 976s for  $V = 4$ , 20 and 50 m/s, respectively.

**COMMENTS:** The maximum Biot number,  $Bi = (\bar{h} + h_r)L/k_{Cu}$ , is associated with  $V = 50$  m/s (maximum  $\bar{h}$  of  $169 \text{ W/m}^2\cdot\text{K}$ ) and  $t = 0$  (maximum  $h_r$  of  $64 \text{ W/m}^2\cdot\text{K}$ ), in which case the maximum Biot number is  $Bi = (233 \text{ W/m}^2\cdot\text{K})(0.025 \text{ m})/(386 \text{ W/m}\cdot\text{K}) = 0.015 < 0.1$ . Hence, the lumped capacitance approximation is valid.

## PROBLEM 6.16

**KNOWN:** Local convection coefficient on rotating disk. Radius and surface temperature of disk. Temperature of stagnant air.

**FIND:** Local heat flux and total heat rate. Nature of boundary layer.

**SCHEMATIC:**

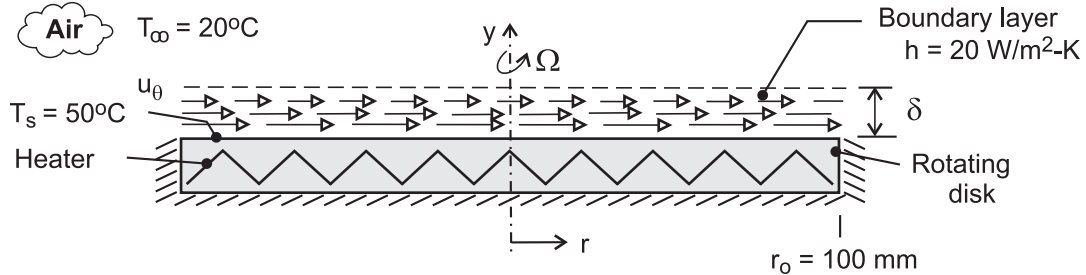

**ASSUMPTIONS:** (1) Negligible heat transfer from back surface and edge of disk.

**ANALYSIS:** If the local convection coefficient is independent of radius, the local heat flux at every point on the disk is

$$q'' = h(T_s - T_\infty) = 20 \text{ W/m}^2 \cdot \text{K} (50 - 20)^\circ\text{C} = 600 \text{ W/m}^2 \quad <$$

Since  $h$  is independent of location,  $\bar{h} = h = 20 \text{ W/m}^2 \cdot \text{K}$  and the total power requirement is

$$P_{\text{elec}} = q = \bar{h}A_s(T_s - T_\infty) = \bar{h}\pi r_o^2(T_s - T_\infty)$$

$$P_{\text{elec}} = (20 \text{ W/m}^2 \cdot \text{K})\pi(0.1\text{m})^2(50 - 20)^\circ\text{C} = 18.9 \text{ W} \quad <$$

If the convection coefficient is independent of radius, the boundary layer must be of uniform thickness  $\delta$ . Within the boundary layer, air flow is principally in the circumferential direction. The circumferential velocity component  $u_\theta$  corresponds to the rotational velocity of the disk at the surface ( $y = 0$ ) and increases with increasing  $r$  ( $u_\theta = \Omega r$ ). The velocity decreases with increasing distance  $y$  from the surface, approaching zero at the outer edge of the boundary layer ( $y \rightarrow \delta$ ).

## PROBLEM 6.17

**KNOWN:** Dimensions and temperatures of rotating and stationary disks, air gap spacing between disks, rotational speed. Correlation for the local Nusselt number.

**FIND:** Value of the average Nusselt number, total heat flux from the disk's top surface, total power requirement. Comment on the nature of the flow between the disks.

**SCHEMATIC:**

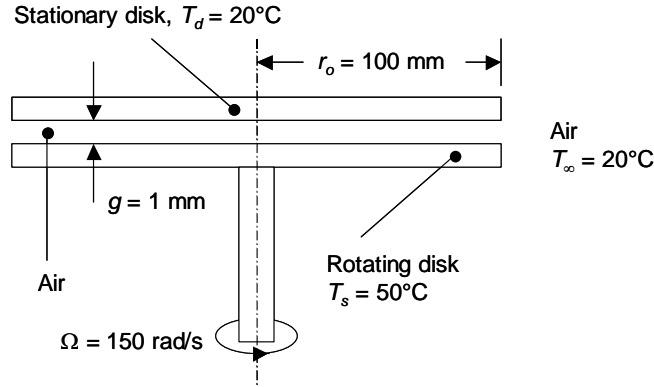

**ASSUMPTIONS:** (1) Steady-state conditions, (2) Constant properties, (3) Negligible viscous dissipation.

**PROPERTIES:** Table A-4, air ( $\bar{T} = (50^\circ\text{C} + 20^\circ\text{C})/2 = 35^\circ\text{C} \approx 308\text{K}$ ):  $\nu = 16.69 \times 10^{-6} \text{ m}^2/\text{s}$ ,  $k = 0.0269 \text{ W/m}\cdot\text{K}$ .

**ANALYSIS:** From the problem statement,  $Nu_r = \frac{h(r)r}{k} = 70(1 + e^{-140G}) Re_{r_o}^{-0.456} Re_r^{0.478}$ .

Since  $Re_r = \Omega r^2 / \nu$ , the local heat transfer coefficient is

$$h(r) = k \left[ 70(1 + e^{-140G}) \left( \frac{\Omega r_o^2}{\nu} \right)^{-0.456} \left( \frac{\Omega}{\nu} \right)^{0.478} \right] r^{-0.044}$$

The average heat transfer coefficient may be evaluated from

$$\bar{h} = \frac{1}{A_s} \int_{A_s} h(r) dA_s = \frac{2\pi k}{\pi r_o^2} \left[ 70(1 + e^{-140G}) \left( \frac{\Omega r_o^2}{\nu} \right)^{-0.456} \left( \frac{\Omega}{\nu} \right)^{0.478} \right] \int_0^{r_o} r \times r^{-0.044} dr$$

or

$$\bar{h} = \frac{1.022k}{r_o^2} \left[ 70(1 + e^{-140G}) \left( \frac{\Omega r_o^2}{\nu} \right)^{-0.456} \left( \frac{\Omega}{\nu} \right)^{0.478} \right] r_o^{1.956}$$

Continued...



### PROBLEM 6.17 (Cont.)

Substituting values,

$$\bar{h} = \frac{1.022 \times 0.0269 \text{ W/m} \cdot \text{K}}{(0.100 \text{ m})^2} \times \left[ 70 \left( 1 + e^{-140 \times 0.01} \right) \left( \frac{150 \text{ rad/s} \times (0.100 \text{ m})^2}{16.69 \times 10^{-6} \text{ m}^2/\text{s}} \right)^{-0.456} \left( \frac{150 \text{ rad/s}}{16.69 \times 10^{-6} \text{ m}^2/\text{s}} \right)^{0.478} \right] (0.100 \text{ m})^{1.956}$$

or

$$\bar{h} = 30.8 \text{ W/m}^2 \cdot \text{K} \quad <$$

The average Nusselt number is

$$\overline{Nu}_D = \bar{h}D/k = 30.8 \text{ W/m}^2 \cdot \text{K} \times 0.200 \text{ m} / 0.0269 \text{ W/m} \cdot \text{K} = 229 \quad <$$

The heat flux from the top surface of the disk is

$$q'' = \bar{h}(T_s - T_d) = 30.8 \text{ W/m}^2 \cdot \text{K} \times (50 - 20)^\circ\text{C} = 924 \text{ W/m}^2 \quad <$$

Therefore, the total electric power requirement is

$$P = q'' A_s = q'' \pi r_o^2 = 924 \text{ W/m}^2 \times \pi \times (0.100 \text{ m})^2 = 29 \text{ W} \quad <$$

Note that if only conduction were occurring between the two disks, the heat flux would be

$$q'' = (k/g)(T_s - T_d) = (0.0269 \text{ W/m} \cdot \text{K} / 0.001 \text{ m}) \times (50 - 20)^\circ\text{C} = 807 \text{ W/m}^2.$$

The conduction heat flux is slightly less than the calculated quantity with rotation, suggesting that advection in the cross-gap direction is small, and that heat transfer between the disks is dominated by conduction. The laminar flow between the disks is characterized by very small velocities in the cross-gap direction.

**COMMENTS:** (1) The slight increase in heat transfer rate is due to edge effects where air can exit or enter the space between the disks, and enhance heat transfer between the disks by mixing. (2) The Reynolds number is  $Re_r = \Omega r_o^2 / \nu = 150 \text{ rad/s} \times (0.100 \text{ m})^2 / 16.69 \times 10^{-6} \text{ m}^2/\text{s} = 90,000$ . Transition to turbulent flow begins at a Reynolds number of approximately 180,000 for this configuration. (3) See Pelle and Harmand, "Heat Transfer Measurements in an Opened Rotor-Stator System Air-Gap," *Experimental Thermal and Fluid Science*, Vol. 31, pp. 165 – 180, 2007, for more information.

## PROBLEM 6.18

**KNOWN:** Air flow over a flat plate of known length, location of transition from laminar to turbulent flow, value of the critical Reynolds number.

**FIND:** (a) Free stream velocity with properties evaluated at  $T = 350$  K, (b) Expression for the average convection coefficient,  $\bar{h}_{\text{lam}}(x)$ , as a function of the distance  $x$  from the leading edge in the laminar region, (c) Expression for the average convection coefficient  $\bar{h}_{\text{turb}}(x)$ , as a function of the distance  $x$  from the leading edge in the turbulent region, (d) Compute and plot the local and average convection coefficients over the entire plate length.

**SCHEMATIC:**

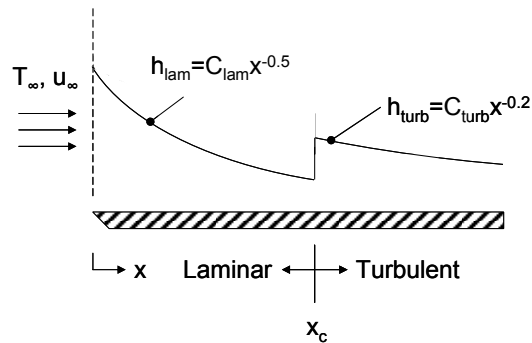

**ASSUMPTIONS:** (1) Steady-state conditions, (2) Constant properties.

**PROPERTIES:** Table A.4, air ( $T = 350$  K):  $k = 0.030$  W/m-K,  $\nu = 20.92 \times 10^{-6}$  m<sup>2</sup>/s,  $Pr = 0.700$ .

**ANALYSIS:**

(a) Using air properties evaluated at 350 K with  $x_c = 0.5$  m,

$$Re_{x,c} = \frac{u_{\infty} x_c}{\nu} = 5 \times 10^5$$

$$u_{\infty} = 5 \times 10^5 \nu / x_c = 5 \times 10^5 \times 20.92 \times 10^{-6} \text{ m}^2/\text{s} / 0.5 \text{ m} = 20.9 \text{ m/s} \quad <$$

(b) From Eq. 6.13, the average coefficient in the laminar region,  $0 \leq x \leq x_c$ , is

$$\bar{h}_{\text{lam}}(x) = \frac{1}{x} \int_0^x h_{\text{lam}}(x) dx = \frac{1}{x} C_{\text{lam}} \int_0^x x^{-0.5} dx = \frac{1}{x} C_{\text{lam}} x^{0.5} = 2 C_{\text{lam}} x^{-0.5} = 2 h_{\text{lam}}(x) \quad (1) \quad <$$

(c) The average coefficient in the turbulent region,  $x_c \leq x \leq L$ , is

$$\bar{h}_{\text{turb}}(x) = \frac{1}{x} \left[ \int_0^{x_c} h_{\text{lam}}(x) dx + \int_{x_c}^x h_{\text{turb}}(x) dx \right] = \left[ C_{\text{lam}} \frac{x^{0.5}}{0.5} \Big|_0^{x_c} + C_{\text{turb}} \frac{x^{0.8}}{0.8} \Big|_{x_c}^x \right]$$

Continued...

**PROBLEM 6.18 (Cont.)**

$$\bar{h}_{\text{turb}}(x) = \frac{1}{x} \left[ 2C_{\text{lam}}x_c^{0.5} + 1.25C_{\text{turb}} \left( x^{0.8} - x_c^{0.8} \right) \right] \quad (2) <$$

(d) The local and average coefficients, Eqs. (1) and (2) are plotted below as a function of  $x$  for the range  $0 \leq x \leq L$ .

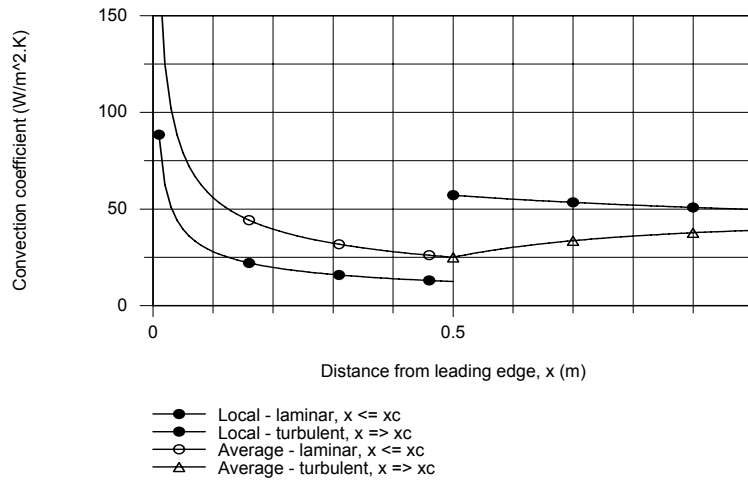

### PROBLEM 6.19

**KNOWN:** Air speed and temperature in a wind tunnel.

**FIND:** (a) Minimum plate length to achieve a Reynolds number of  $10^8$ , (b) Distance from leading edge at which transition would occur.

**SCHEMATIC:**

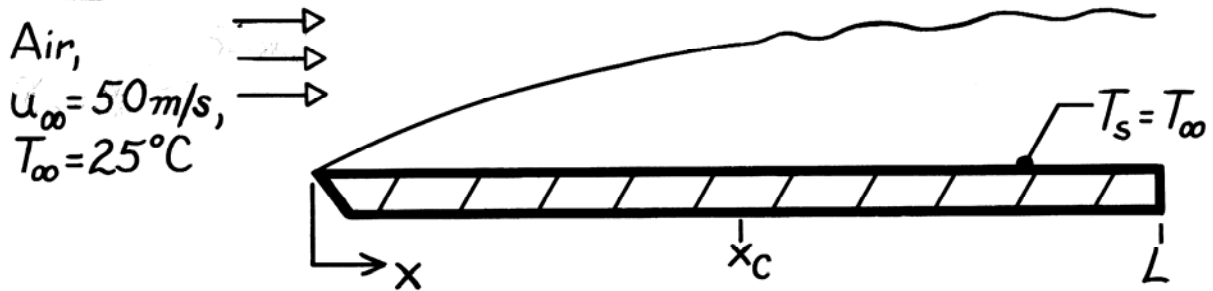

**ASSUMPTIONS:** (1) Isothermal conditions,  $T_s = T_\infty$ .

**PROPERTIES:** Table A-4, Air ( $25^\circ\text{C} = 298\text{K}$ ):  $\nu = 15.71 \times 10^{-6} \text{ m}^2/\text{s}$ .

**ANALYSIS:** (a) The Reynolds number is

$$\text{Re}_x = \frac{\rho u_\infty x}{\mu} = \frac{u_\infty x}{\nu}$$

To achieve a Reynolds number of  $1 \times 10^8$ , the minimum plate length is then

$$L_{\min} = \frac{\text{Re}_x \nu}{u_\infty} = \frac{1 \times 10^8 (15.71 \times 10^{-6} \text{ m}^2/\text{s})}{50 \text{ m/s}}$$

$$L_{\min} = 31.4 \text{ m.} \quad <$$

(b) For a transition Reynolds number of  $5 \times 10^5$

$$x_c = \frac{\text{Re}_{x,c} \nu}{u_\infty} = \frac{5 \times 10^5 (15.71 \times 10^{-6} \text{ m}^2/\text{s})}{50 \text{ m/s}}$$

$$x_c = 0.157 \text{ m.} \quad <$$

**COMMENTS:** Note that

$$\frac{x_c}{L} = \frac{\text{Re}_{x,c}}{\text{Re}_L}$$

This expression may be used to quickly establish the location of transition from knowledge of  $\text{Re}_{x,c}$  and  $\text{Re}_L$ .

## PROBLEM 6.20

**KNOWN:** Flat plate in parallel flow, free stream velocity, expressions for the local heat transfer coefficient under laminar and fully turbulent conditions. Water temperature of 300K.

**FIND:** Plate length for which the average heat transfer coefficient is the same for laminar and turbulent flow conditions.

**SCHEMATIC:**

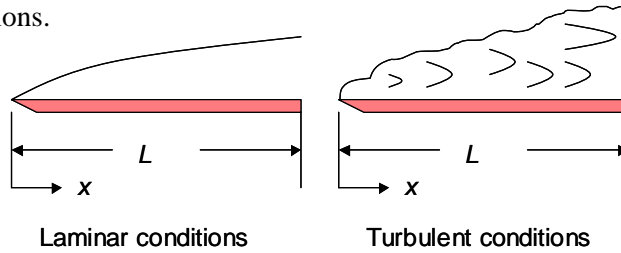

**ASSUMPTIONS:** (1) Steady-state conditions, (2) Negligible viscous dissipation.

**ANALYSIS:** For laminar conditions and turbulent conditions,

$$\bar{h}_{\text{lam}} = \frac{1}{L} \int_0^L h_{\text{lam}} dx = 2C_{\text{lam}} L^{-0.5} \quad ; \quad \bar{h}_{\text{turb}} = \frac{1}{L} \int_0^L h_{\text{turb}} dx = 1.25C_{\text{turb}} L^{-0.2}$$

or

$$\frac{\bar{h}_{\text{lam}}}{\bar{h}_{\text{turb}}} = 1 = \frac{2 \times 395 \text{ W/m}^{1.5} \cdot \text{K}}{1.25 \times 2330 \text{ W/m}^{1.8} \cdot \text{K}} L^{-0.30} = (0.271 \text{ m}^{0.30}) L^{-0.30}$$

or

$$L = (0.271 \text{ m}^{0.30})^{3.3333} = 0.0128 \text{ m} = 12.8 \text{ mm} \quad <$$

**COMMENTS:** (1) A plot of the local laminar and turbulent convection coefficient distributions is shown. The areas under the two curves are identical, reflecting the fact

that  $\frac{\bar{h}_{\text{lam}}}{\bar{h}_{\text{turb}}} = 1$ . (2) A plate shorter than  $L =$

12.8 mm is predicted to provide higher average coefficients under laminar flow conditions, as opposed to when turbulent conditions exist. However, this result may not be reliable because experimental measurement of local heat transfer coefficients is difficult, and the expressions of Example 6.4 may not be of sufficient accuracy to apply to such a short plate. (3) The plate is much shorter than the transition length,  $x_c = 0.43 \text{ m}$ , that was calculated in Example 6.4. Hence, the laminar case is not subjected to a transition to turbulent flow.

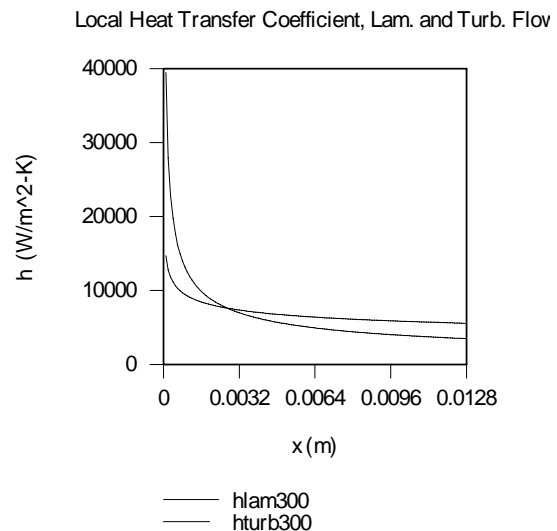

## PROBLEM 6.21

**KNOWN:** Transition Reynolds number. Velocity and temperature of atmospheric air, engine oil, and mercury flow over a flat plate.

**FIND:** Distance from leading edge at which transition occurs for each fluid.

**SCHEMATIC:**

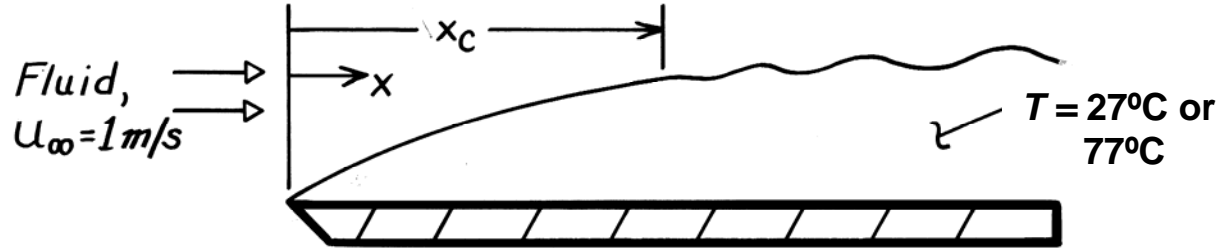

**ASSUMPTIONS:** Transition Reynolds number is  $Re_{x,c} = 5 \times 10^5$ .

**PROPERTIES:** For the fluids at  $T = 300 \text{ K}$  and  $350 \text{ K}$ :

<i>Fluid</i>	<i>Table</i>	$\nu (\text{m}^2/\text{s})$	
		$T = 300 \text{ K}$	$T = 350 \text{ K}$
Air (1 atm)	A-4	$15.89 \times 10^{-6}$	$20.92 \times 10^{-6}$
Engine Oil	A-5	$550 \times 10^{-6}$	$41.7 \times 10^{-6}$
Mercury	A-5	$0.1125 \times 10^{-6}$	$0.0976 \times 10^{-6}$

**ANALYSIS:** The point of transition is

$$x_c = Re_{x,c} \frac{\nu}{u_\infty} = \frac{5 \times 10^5}{1 \text{ m/s}} \nu.$$

Substituting appropriate viscosities, find

<i>Fluid</i>	$x_c (\text{m})$		<
	$T = 300 \text{ K}$	$T = 350 \text{ K}$	
Air	7.95	10.5	
Oil	275	20.9	
Mercury	0.056	0.049	

**COMMENTS:** (1) Note the great disparity in transition length for the different fluids. Due to the effect which viscous forces have on attenuating the instabilities which bring about transition, the distance required to achieve transition increases with increasing  $\nu$ . (2) Note the temperature-dependence of the transition length, in particular for engine oil. (3) As shown in Example 6.4, the variation of the transition location can have a significant effect on the average heat transfer coefficient associated with convection to or from the plate.

## PROBLEM 6.22

**KNOWN:** Pressure dependence of the dynamic viscosity, thermal conductivity and specific heat.

**FIND:** (a) Variation of the kinematic viscosity and thermal diffusivity with pressure for an incompressible liquid and an ideal gas, (b) Value of the thermal diffusivity of air at 350 K for pressures of 1, 5 and 10 atm, (c) Location where transition occurs for air flow over a flat plate with  $T_\infty = 350$  K,  $p = 1, 5$  and 10 atm, and  $u_\infty = 2$  m/s.

**ASSUMPTIONS:** (1) Steady-state conditions, (2) Constant properties, (3) Transition at  $Re_{x,c} = 5 \times 10^5$ , (4) Ideal gas behavior.

**PROPERTIES:** Table A.4, air (350 K):  $\mu = 208.2 \times 10^{-7}$  N·s/m<sup>2</sup>,  $k = 0.030$  W/m·K,  $c_p = 1009$  J/kg·K,  $\rho = 0.995$  kg/m<sup>3</sup>.

### ANALYSIS:

(a) For an ideal gas

$$p = \rho RT \text{ or } \rho = p/RT \quad (1)$$

while for an incompressible liquid,  $\rho = \text{constant}$  (2)

The kinematic viscosity is  $v = \mu/\rho$  (3)

Therefore, for an ideal gas

$$v = \mu RT/p \text{ or } v \propto p^{-1} \quad (4) <$$

and for an incompressible liquid

$$v = \mu/\rho \text{ or } v \text{ is independent of pressure.} \quad <$$

The thermal diffusivity is

$$\alpha = k/\rho c$$

Therefore, for an ideal gas,

$$\alpha = kRT/pc \text{ or } \alpha \propto p^{-1} \quad (6) <$$

For an incompressible liquid  $\alpha = k/\rho c$  or  $\alpha$  is independent of pressure <

(b) For  $T = 350$  K,  $p = 1$  atm, the thermal diffusivity of air is

$$\alpha = \frac{0.030 \text{ W/m} \cdot \text{K}}{0.995 \text{ kg/m}^3 \times 1009 \text{ J/kg} \cdot \text{K}} = 29.9 \times 10^{-6} \text{ m}^2/\text{s} \quad <$$

Using Equation 6, at  $p = 5$  atm,

Continued...

### PROBLEM 6.22 ( Cont.)

$$\alpha = 29.9 \times 10^{-6} \text{ m}^2/\text{s}/5 = 5.98 \times 10^{-6} \text{ m}^2/\text{s} \quad <$$

At  $p = 10 \text{ atm}$ ,

$$\alpha = 29.9 \times 10^{-6} \text{ m}^2/\text{s}/10 = 2.99 \times 10^{-6} \text{ m}^2/\text{s} \quad <$$

(c) For transition over a flat plate,

$$\text{Re}_{x,c} = \frac{x_c u_\infty}{\nu} = 5 \times 10^5$$

Therefore

$$x_c = 5 \times 10^5 (\nu/u_\infty)$$

For  $T_\infty = 350 \text{ K}$ ,  $p = 1 \text{ atm}$ ,

$$\nu = \mu/\rho = 208.2 \times 10^{-7} \text{ N}\cdot\text{s}/\text{m}^2 / 0.995 \text{ kg}/\text{m}^3 = 20.92 \times 10^{-6} \text{ m}^2/\text{s}$$

Using Equation 4, at  $p = 5 \text{ atm}$

$$\nu = 20.92 \times 10^{-6} \text{ m}^2/\text{s}/5 = 4.18 \times 10^{-6} \text{ m}^2/\text{s}$$

At  $p = 10 \text{ atm}$ ,

$$\nu = 20.92 \times 10^{-6} \text{ m}^2/\text{s}/10 = 2.09 \times 10^{-6} \text{ m}^2/\text{s}$$

Therefore, at  $p = 1 \text{ atm}$

$$x_c = 5 \times 10^5 \times 20.92 \times 10^{-6} \text{ m}^2/\text{s}/(2\text{m}/\text{s}) = 5.23 \text{ m} \quad <$$

At  $p = 5 \text{ atm}$ ,

$$x_c = 5 \times 10^5 \times 4.18 \times 10^{-6} \text{ m}^2/\text{s}/(2\text{m}/\text{s}) = 1.05 \text{ m} \quad <$$

At  $p = 10 \text{ atm}$

$$x_c = 5 \times 10^5 \times 2.09 \times 10^{-6} \text{ m}^2/\text{s}/(2\text{m}/\text{s}) = 0.523 \text{ m} \quad <$$

**COMMENT:** Note the strong dependence of the transition length upon the pressure for the gas (the transition length is independent of pressure for the incompressible liquid).



## PROBLEM 6.23

**KNOWN:** Velocity of water flowing over a flat plate. Length of plate. Variation of local convection coefficient with  $x$ . Water temperature.

**FIND:** Average convection coefficient for roughness applied over the range  $0 \leq x_r \leq L$ .

**SCHEMATIC:**

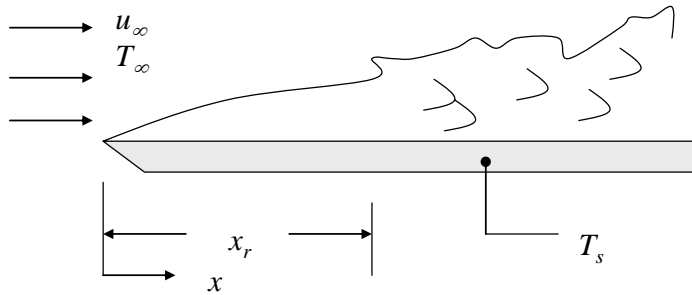

**ASSUMPTIONS:** (1) Steady-state conditions, (2) Constant properties, (3) Transition occurs at a critical Reynolds number of  $5 \times 10^5$  for the smooth plate, (4) Incompressible flow.

**PROPERTIES:** Table A.6, Water ( $T = 300$  K):  $\rho = \nu_f^{-1} = 997$  kg/m<sup>3</sup>,  $\mu = 855 \times 10^{-6}$  N·s/m<sup>2</sup>.

**ANALYSIS:** For roughness applied over the range  $0 \leq x_r \leq x_c = 0.43$  m, transition occurs at  $x_r$ . From Eq. 6.14,

$$\begin{aligned} \bar{h} &= \frac{1}{L} \int_0^L h dx = \frac{1}{L} \left[ \int_0^{x_r} h_{\text{lam}} dx + \int_{x_r}^L h_{\text{turb}} dx \right] = \frac{1}{L} \left[ \frac{C_{\text{lam}}}{0.5} x^{0.5} \Big|_0^{x_r} + \frac{C_{\text{turb}}}{0.8} x^{0.8} \Big|_{x_r}^L \right] \\ &= \frac{1}{L} \left[ \frac{C_{\text{lam}}}{0.5} x_r^{0.5} + \frac{C_{\text{turb}}}{0.8} (L^{0.8} - x_r^{0.8}) \right] = \frac{1}{0.6 \text{ m}} \left[ \frac{395 \text{ W/m}^{1.5} \cdot \text{K}}{0.5} x_r^{0.5} + \frac{2330 \text{ W/m}^{1.8} \cdot \text{K}}{0.8} ((0.6 \text{ m})^{0.8} - x_r^{0.8}) \right] \\ &= \frac{1}{0.6 \text{ m}} \left[ \frac{395 \text{ W/m}^{1.5} \cdot \text{K}}{0.5} x_r^{0.5} + \frac{2330 \text{ W/m}^{1.8} \cdot \text{K}}{0.8} ((0.6 \text{ m})^{0.8} - x_r^{0.8}) \right] \\ &= 1317 \text{ W/m}^{2.5} \cdot \text{K} \times x_r^{0.5} + 3226 \text{ W/m}^2 \cdot \text{K} - 4854 \text{ W/m}^{2.8} \cdot \text{K} \times x_r^{0.8} \end{aligned}$$

Roughness applied over the range  $x_r > 0.43$  has no effect on the transition since the transition occurs at  $x_c = 0.43$  m for the smooth plate. That is,  $\bar{h} = 1620$  W/m<sup>2</sup> · K.

This result is plotted below for  $0 \leq x_r \leq 0.6$  m.

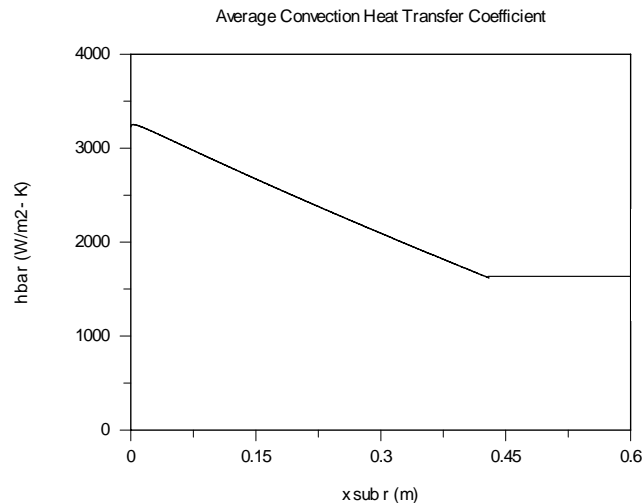

Continued...

### PROBLEM 6.23 (Cont.)

The maximum value of  $\bar{h}$  exists when transition occurs very close to the leading edge of the plate, at  $x_r = 0.003$  m. It does not occur exactly at the leading edge because the laminar heat transfer coefficient equation yields a slightly higher value than the turbulent heat transfer coefficient equation very near  $x = 0$ . <

The minimum value of  $\bar{h}$  exists when  $x_r > x_c = 0.43$  m. <

**COMMENTS:** (1) Turbulent heat transfer coefficients are usually (but not always) larger than laminar heat transfer coefficients. Therefore, tripping the transition to turbulence at or near the leading edge results in enhanced heat transfer. (2) The conclusion that the laminar heat transfer coefficient is slightly higher than the turbulent heat transfer coefficient very near  $x = 0$  may not be accurate. Turbulent heat transfer coefficient measurements are usually not performed very close to the leading edge since, in most cases, turbulence develops further downstream. (3) Adding roughness at  $x$  locations downstream of where the transition to turbulence would normally occur has no influence on the transition or the average heat transfer rate.

## PROBLEM 6.24

**KNOWN:** Nondimensional form of the  $x$ -direction velocity boundary layer equation and boundary conditions, expressions for  $x^*$ ,  $y^*$ ,  $u^*$  and  $v^*$ . Laminar, incompressible flow.

**FIND:** Expressions for (a) the velocity boundary conditions and (b)  $x$ -momentum equation in dimensional form.

**SCHEMATIC:**

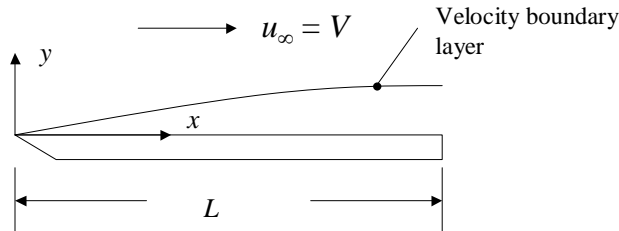

**ASSUMPTIONS:** (1) Steady-state conditions, (2) Constant properties.

**ANALYSIS:** (a) From Equation 6.38, the boundary conditions in nondimensional form are

$$u^*(x^*, 0) = 0 \quad (1)$$

$$v^*(x^*, 0) = 0 \quad (2)$$

$$u^*(x^*, \infty) = \frac{u_\infty(x^*)}{V} \quad (3)$$

Substituting  $u^* = \frac{u}{V}$  from Equation 6.32 and  $x^* = \frac{x}{L}$  from Equation 6.31 into Equation (1) yields

$$\frac{u}{V}(x/L, 0) = 0. \text{ After multiplying both sides of the resultant equation by } V, \text{ we have } u(x/L, y=0) = 0.$$

Hence, the  $x$ -component of the fluid velocity at any  $x$  location along the surface is zero. <

Substituting  $v^* = v/V$  from Equation 6.32 and  $x^* = \frac{x}{L}$  from Equation 6.31 into Equation (2)

$$\text{yields } \frac{v}{V}(x/L, 0) = 0. \text{ After multiplying both sides of the equation by } V, \text{ we have } v(x/L, y=0) = 0.$$

Hence, the  $y$ -component of the fluid velocity at any  $x$  location along the surface is zero. <

The preceding two results are the familiar *zero velocity boundary conditions* that exist at an impenetrable, stationary surface.

Substituting  $u^* = \frac{u}{V}$  from Equation 6.32 and  $x^* = \frac{x}{L}$  from Equation 6.31 into Equation (3) yields

$$\frac{u}{V}(x/L, \infty) = \frac{u_\infty(x/L)}{V} = \frac{V}{V} = 1. \text{ After multiplying both sides of the resultant equation by } V, \text{ we have}$$

$$u(x/L, y \rightarrow \infty) = V = u_\infty. \text{ Hence, the } x\text{-component of the velocity at any } x \text{ location outside of the}$$

boundary layer is equal to the free stream value. <

Continued...

**PROBLEM 6.24 (Cont.)**

(b) Note that  $\frac{\partial u^*}{\partial x^*} = \frac{\partial(u/V)}{\partial(x/L)} = \frac{L}{V} \frac{\partial u}{\partial x}$ . Likewise,  $\frac{\partial u^*}{\partial y^*} = \frac{\partial(u/V)}{\partial(y/L)} = \frac{L}{V} \frac{\partial u}{\partial y}$  and

$\frac{\partial^2 u^*}{\partial y^{*2}} = \frac{\partial}{\partial y^*} \left( \frac{\partial u^*}{\partial y^*} \right) = \frac{\partial}{\partial(y/L)} \left( \frac{L}{V} \frac{\partial u}{\partial y} \right) = \frac{L^2}{V} \frac{\partial^2 u}{\partial y^2}$ . Also, from the definition of  $p^*$ , we note that

$-\frac{\partial p^*}{\partial x^*} = -\frac{\partial(p_\infty / \rho V^2)}{\partial(x/L)} = -\frac{L}{\rho V^2} \frac{\partial p_\infty}{\partial x} = 0$ . Substituting the preceding expressions, along with the

definition of the Reynolds number,  $Re_L = \rho VL / \mu = VL / \nu$  into Equation 6.35 yields

$\frac{u}{V} \frac{L}{V} \frac{\partial u}{\partial x} + \frac{\nu}{V} \frac{L}{V} \frac{\partial u}{\partial y} = 0 + \frac{\nu}{VL} \frac{L^2}{V} \frac{\partial^2 u}{\partial y^2}$ . Multiplying both sides of the preceding equation by  $\frac{V^2}{L}$  gives

$u \frac{\partial u}{\partial x} + \nu \frac{\partial u}{\partial y} = \nu \frac{\partial^2 u}{\partial y^2}$  which is identical to Equation 6.28 for the case where  $\frac{dp_\infty}{dx} = 0$ . <

**COMMENTS:** (1) Equations 6.35 and 6.38 are nondimensional forms of Equations 6.28 and the no-slip boundary conditions. When converted to their nondimensional forms, the equations explicitly illustrate the importance of the Reynolds number in describing the velocity boundary layer. (2) For a flat plate subject to parallel flow, the Reynolds number is usually expressed as  $Re_L = u_\infty L / \nu$ , since  $u_\infty = V$ .

## PROBLEM 6.25

**KNOWN:** Nondimensional form of the thermal boundary layer equation and boundary conditions, expressions for  $x^*$ ,  $y^*$ ,  $u^*$ ,  $v^*$  and  $T^*$ . Laminar, incompressible flow with negligible viscous dissipation.

**FIND:** Expressions for (a) the thermal boundary conditions and (b) energy equation in dimensional form.

**SCHEMATIC:**

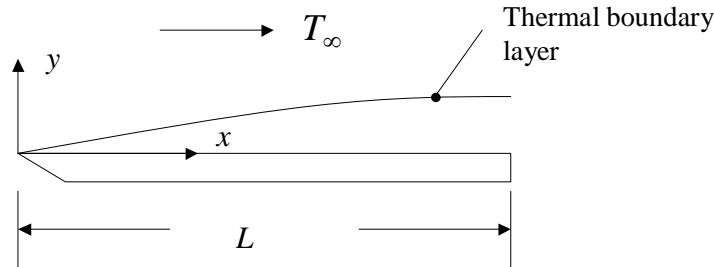

**ASSUMPTIONS:** (1) Steady-state conditions, (2) Constant properties.

**ANALYSIS:** (a) From Equation 6.39, the thermal boundary conditions in nondimensional form are

$$T^*(x^*, 0) = 0 \quad (1)$$

$$T^*(x^*, \infty) = 1 \quad (2)$$

Substituting  $T^* = \frac{T - T_s}{T_\infty - T_s}$  from Equation 6.33 and  $x^* = \frac{x}{L}$  from Equation 6.31 into Equation (1) yields

$\frac{T(x/L, 0) - T_s}{T_\infty - T_s} = 0$ . After multiplying both sides of the resultant equation by  $T_\infty - T_s$ , we have

$T(x/L, y = 0) = T_s$ . Hence, the fluid temperature at any  $x$  location along the surface is  $T_s$ . <

Substituting  $T^* = \frac{T - T_s}{T_\infty - T_s}$  from Equation 6.33 and  $x^* = \frac{x}{L}$  from Equation 6.31 into Equation (2)

yields  $\frac{T(x/L, y \rightarrow \infty) - T_s}{T_\infty - T_s} = 1$ . After multiplying both sides of the equation by  $T_\infty - T_s$ , we

have  $T(x/L, y \rightarrow \infty) = T_\infty$ . Hence, the fluid temperature at any  $x$  location outside of the boundary layer is equal to the free stream value. <

(b) Note that  $\frac{\partial T^*}{\partial x^*} = \frac{\partial \left( \frac{T - T_s}{T_\infty - T_s} \right)}{\partial (x/L)} = \frac{L}{T_\infty - T_s} \frac{\partial T}{\partial x}$ . Likewise,  $\frac{\partial T^*}{\partial y^*} = \frac{\partial \left( \frac{T - T_s}{T_\infty - T_s} \right)}{\partial (y/L)} = \frac{L}{T_\infty - T_s} \frac{\partial T}{\partial y}$ .

Also, note that  $\frac{\partial^2 T^*}{\partial y^{*2}} = \frac{\partial}{\partial y^*} \left( \frac{\partial T^*}{\partial y^*} \right) = \frac{L}{T_\infty - T_s} \frac{\partial}{\partial (y/L)} \frac{\partial T}{\partial y} = \frac{L^2}{T_\infty - T_s} \frac{\partial^2 T}{\partial y^2}$ . Substituting the

preceding expressions, along with  $x^* = x/L$ ,  $y^* = y/L$ ,  $Re_L = \frac{VL}{\nu}$  and  $Pr = \frac{\nu}{\alpha}$  into Equation 6.36

Continued...

### PROBLEM 6.25 (Cont.)

yields  $\frac{u}{V} \frac{L}{(T_\infty - T_s)} \frac{\partial T}{\partial x} + \frac{v}{V} \frac{L}{(T_\infty - T_s)} \frac{\partial T}{\partial y} = \frac{v}{VL} \frac{\alpha}{\nu} \frac{L^2}{(T_\infty - T_s)} \frac{\partial^2 T}{\partial y^2}$ . Multiplying both sides by  $\frac{V(T_\infty - T_s)}{L}$  gives  $u \frac{\partial T}{\partial x} + v \frac{\partial T}{\partial y} = \alpha \frac{\partial^2 T}{\partial y^2}$  which is identical to Equation 6.29 when viscous dissipation is negligible. <

**COMMENTS:** (1) Equations 6.36 and 6.39 are nondimensional forms of Equations 6.29 and the boundary conditions. When converted to their nondimensional forms, the resulting equations explicitly illustrate the importance of the Reynolds and Prandtl numbers in describing the thermal boundary layer. (2) For a flat plate subject to parallel flow, the Reynolds number is usually expressed as  $Re_L = \rho u_\infty L / \mu$ , or  $u_\infty L / \nu$  since  $u_\infty = V$ .

## PROBLEM 6.26

**KNOWN:** Critical Reynolds number for a cylinder in cross flow. Critical Mach number.

**FIND:** Critical cylinder diameter below which, if the flow of air at atmospheric pressure and temperature is turbulent, compressibility effects may be important.

**SCHEMATIC:**

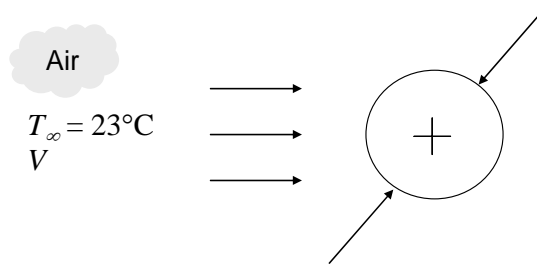

**ASSUMPTIONS:** (1) Steady-state conditions. (2) Air behaves as an ideal gas.

**PROPERTIES:** Table A.4, air ( $T = 300$  K):  $\mathcal{M} = 28.97$  kg/kmol,  $c_p = 1.007$  kJ/kg·K,  $\mu = 184.6 \times 10^{-7}$  N·s/m<sup>2</sup>.

**ANALYSIS:** The density of an ideal gas may be found from the equation of state,

$$\rho = \frac{p}{RT}$$

and the speed of sound for an ideal gas is  $a = \sqrt{\gamma RT}$ .

From the definition of the Mach number, the air velocity may be expressed as

$$V = Ma \cdot a$$

Substituting the preceding equations into the definition of the Reynolds number yields

$$Re_D = \frac{VD}{\nu} = \frac{VD\rho}{\mu} = \frac{Ma\sqrt{\gamma RT}Dp}{\mu RT} D = \frac{Ma}{\mu} \sqrt{\frac{\gamma}{RT}} Dp$$

Letting  $Re = Re_c$  and  $Ma = Ma_c$ , the preceding equation can be rearranged to write an expression for the critical cylinder diameter,

$$D_c = \frac{Re_c}{Ma_c} \sqrt{\frac{RT}{\gamma}} \frac{\mu}{p}$$

Before evaluating the critical cylinder diameter, we note that the gas constant for air is

Continued...

### PROBLEM 6.26 (Cont.)

$$R = \frac{\mathcal{R}}{\mathcal{M}} = \frac{8315 \text{ J/kmol} \cdot \text{K}}{28.97 \text{ kg/kmol}} = 287 \text{ J/kg} \cdot \text{K}$$

and the specific heat at constant volume,  $c_v$ , is

$$c_v = c_p - R = 1007 \text{ J/kg} \cdot \text{K} - 287 \text{ J/kg} \cdot \text{K} = 720 \text{ J/kg} \cdot \text{K}$$

Therefore, the ratio of specific heats for air is

$$\gamma = \frac{c_p}{c_v} = \frac{1007 \text{ J/kg} \cdot \text{K}}{720 \text{ J/kg} \cdot \text{K}} = 1.399$$

For the conditions of the problem, the critical cylinder diameter is

$$D_c = \frac{Re_c}{Ma_c} \sqrt{\frac{RT}{\gamma}} \frac{\mu}{p} = \frac{2 \times 10^5}{0.3} \sqrt{\frac{287 \text{ J/kg} \cdot \text{K} \times 300 \text{ K}}{1.399}} \times \frac{184.6 \times 10^{-7} \text{ N} \cdot \text{s/m}^2}{1.0133 \times 10^5 \text{ N/m}^2} = 0.030 \text{ m} = 30 \text{ mm} <$$

**COMMENTS:** (1) The expression for the critical Reynolds number ( $Re_{D,c} = 2 \times 10^5$ ) is plotted using *log-log* scales in the figure below. Laminar flow occurs to the left of the sloped line, while turbulent flow occurs to the right of the sloped line. The velocity associated with the critical Mach number is identified by the horizontal line that separates regions of incompressible flow (below the horizontal line) and compressible flow (above the horizontal line). From this plot, it is evident that below the critical cylinder diameter,  $D_c$ , if the flow is turbulent, compressibility effects may be important. If the flow is laminar, the flow may or may not be compressible. In general, turbulent flow is difficult to achieve in situations involving small length scales.

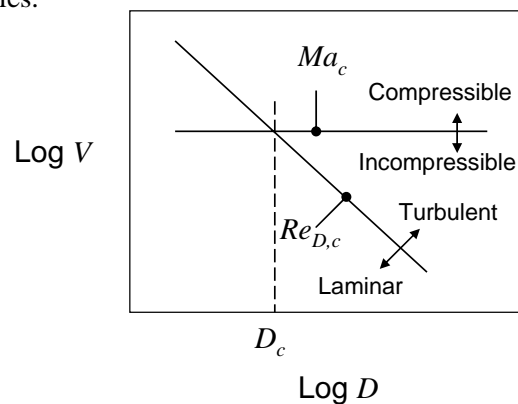

(2) The value of the critical Reynolds number is geometry-dependent. Care must be taken to apply the correct value of the critical Reynolds number in any calculation involving convection heat transfer.



### PROBLEM 6.27

**KNOWN:** Characteristic length, surface temperature and average heat flux for an object placed in an airstream of prescribed temperature and velocity.

**FIND:** Average convection coefficient if characteristic length of object is increased by a factor of five and air velocity is decreased by a factor of five.

**SCHEMATIC:**

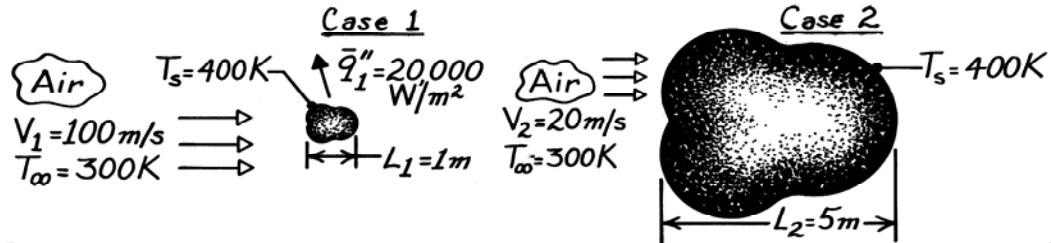

**ASSUMPTIONS:** (1) Steady-state conditions, (2) Constant properties.

**ANALYSIS:** For a particular geometry,

$$\overline{Nu}_L = f(\text{Re}_L, \text{Pr}).$$

The Reynolds numbers for each case are

$$\text{Case 1:} \quad \text{Re}_{L,1} = \frac{V_1 L_1}{\nu_1} = \frac{(100 \text{ m/s}) 1 \text{ m}}{\nu_1} = \frac{100 \text{ m}^2/\text{s}}{\nu_1}$$

$$\text{Case 2:} \quad \text{Re}_{L,2} = \frac{V_2 L_2}{\nu_2} = \frac{(20 \text{ m/s}) 5 \text{ m}}{\nu_2} = \frac{100 \text{ m}^2/\text{s}}{\nu_2}.$$

Hence, with  $\nu_1 = \nu_2$ ,  $\text{Re}_{L,1} = \text{Re}_{L,2}$ . Since  $\text{Pr}_1 = \text{Pr}_2$ , it follows that

$$\overline{Nu}_{L,2} = \overline{Nu}_{L,1}.$$

Hence,

$$\begin{aligned} \overline{h}_2 L_2 / k_2 &= \overline{h}_1 L_1 / k_1 \\ \overline{h}_2 &= \overline{h}_1 \frac{L_1}{L_2} = 0.2 \overline{h}_1. \end{aligned}$$

For *Case 1*, using the rate equation, the convection coefficient is

$$\begin{aligned} q_1 &= \overline{h}_1 A_1 (T_s - T_\infty)_1 \\ \overline{h}_1 &= \frac{(q_1 / A_1)}{(T_s - T_\infty)_1} = \frac{q_1''}{(T_s - T_\infty)_1} = \frac{20,000 \text{ W/m}^2}{(400 - 300) \text{ K}} = 200 \text{ W/m}^2 \cdot \text{K}. \end{aligned}$$

Hence, it follows that for *Case 2*

$$\overline{h}_2 = 0.2 \times 200 \text{ W/m}^2 \cdot \text{K} = 40 \text{ W/m}^2 \cdot \text{K}. \quad <$$

**COMMENTS:** If  $\text{Re}_{L,2}$  were *not* equal to  $\text{Re}_{L,1}$ , it would be necessary to know the specific form of  $f(\text{Re}_L, \text{Pr})$  before  $\overline{h}_2$  could be determined.

## PROBLEM 6.28

**KNOWN:** Heat transfer rate from a turbine blade for prescribed operating conditions.

**FIND:** Heat transfer rate from a larger blade operating under different conditions.

**SCHEMATIC:**

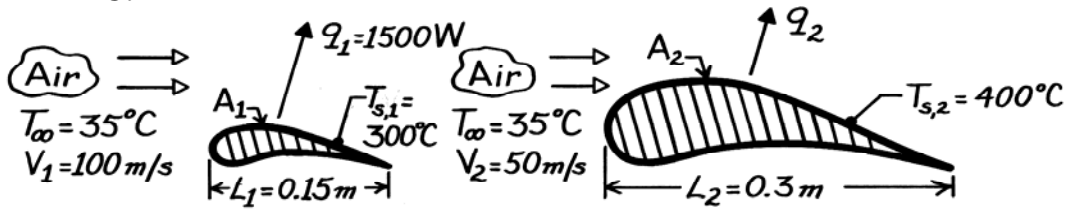

**ASSUMPTIONS:** (1) Steady-state conditions, (2) Constant properties, (3) Surface area  $A$  is directly proportional to characteristic length  $L$ , (4) Negligible radiation, (5) Blade shapes are geometrically similar.

**ANALYSIS:** For a prescribed geometry,

$$\overline{Nu} = \frac{\bar{h}L}{k} = f(\text{Re}_L, \text{Pr}).$$

The Reynolds numbers for the blades are

$$\text{Re}_{L,1} = (V_1 L_1 / \nu) = 15 / \nu \quad \text{Re}_{L,2} = (V_2 L_2 / \nu) = 15 / \nu.$$

Hence, with constant properties,  $\text{Re}_{L,1} = \text{Re}_{L,2}$ . Also,  $\text{Pr}_1 = \text{Pr}_2$ . Therefore,

$$\begin{aligned} \overline{Nu}_2 &= \overline{Nu}_1 \\ (\bar{h}_2 L_2 / k) &= (\bar{h}_1 L_1 / k) \\ \bar{h}_2 &= \frac{L_1}{L_2} \bar{h}_1 = \frac{L_1}{L_2} \frac{q_1}{A_1 (T_{s,1} - T_\infty)}. \end{aligned}$$

Hence, the heat rate for the *second blade* is

$$\begin{aligned} q_2 &= \bar{h}_2 A_2 (T_{s,2} - T_\infty) = \frac{L_1}{L_2} \frac{A_2}{A_1} \frac{(T_{s,2} - T_\infty)}{(T_{s,1} - T_\infty)} q_1 \\ q_2 &= \frac{T_{s,2} - T_\infty}{T_{s,1} - T_\infty} q_1 = \frac{(400 - 35)}{(300 - 35)} (1500 \text{ W}) \end{aligned}$$

$$q_2 = 2066 \text{ W.} \quad <$$

**COMMENTS:** The slight variation of  $\nu$  from Case 1 to Case 2 would cause  $\text{Re}_{L,2}$  to differ from  $\text{Re}_{L,1}$ . However, for the prescribed conditions, this non-constant property effect is small.

### PROBLEM 6.29

**KNOWN:** Experimental measurements of the heat transfer coefficient for a square bar in cross flow.

**FIND:** (a)  $\bar{h}$  for the condition when  $L = 1\text{m}$  and  $V = 15\text{m/s}$ , (b)  $\bar{h}$  for the condition when  $L = 1\text{m}$  and  $V = 30\text{m/s}$ , (c) Effect of defining a side as the characteristic length.

**SCHEMATIC:**

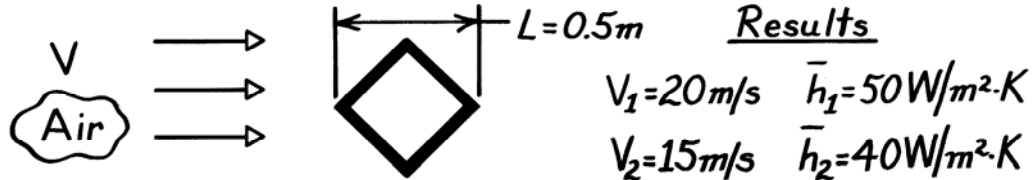

**ASSUMPTIONS:** (1) Functional form  $\bar{Nu} = CRe^m Pr^n$  applies with  $C$ ,  $m$ ,  $n$  being constants, (2) Constant properties.

**ANALYSIS:** (a) For the experiments and the condition  $L = 1\text{m}$  and  $V = 15\text{m/s}$ , it follows that  $Pr$  as well as  $C$ ,  $m$ , and  $n$  are constants. Hence

$$\bar{h}L \propto (VL)^m.$$

Using the experimental results, find  $m$ . Substituting values

$$\frac{\bar{h}_1 L_1}{\bar{h}_2 L_2} = \left[ \frac{V_1 L_1}{V_2 L_2} \right]^m \quad \frac{50 \times 0.5}{40 \times 0.5} = \left[ \frac{20 \times 0.5}{15 \times 0.5} \right]^m$$

giving  $m = 0.782$ . It follows then for  $L = 1\text{m}$  and  $V = 15\text{m/s}$ ,

$$\bar{h} = \bar{h}_1 \frac{L_1}{L} \left[ \frac{V \cdot L}{V_1 \cdot L_1} \right]^m = 50 \frac{\text{W}}{\text{m}^2 \cdot \text{K}} \times \frac{0.5}{1.0} \left[ \frac{15 \times 1.0}{20 \times 0.5} \right]^{0.782} = 34.3 \text{W/m}^2 \cdot \text{K}. \quad <$$

(b) For the condition  $L = 1\text{m}$  and  $V = 30\text{m/s}$ , find

$$\bar{h} = \bar{h}_1 \frac{L_1}{L} \left[ \frac{V \cdot L}{V_1 \cdot L_1} \right]^m = 50 \frac{\text{W}}{\text{m}^2 \cdot \text{K}} \times \frac{0.5}{1.0} \left[ \frac{30 \times 1.0}{20 \times 0.5} \right]^{0.782} = 59.0 \text{W/m}^2 \cdot \text{K}. \quad <$$

(c) If the characteristic length were chosen as a side rather than the diagonal, the value of  $C$  would change. However, the coefficients  $m$  and  $n$  would not change.

**COMMENTS:** The foregoing Nusselt number relation is used frequently in heat transfer analysis, providing appropriate scaling for the effects of length, velocity, and fluid properties on the heat transfer coefficient.

### PROBLEM 6.30

**KNOWN:** Form of the Nusselt number correlation for forced convection and fluid properties.

**FIND:** Expression for figure of merit  $F_F$  and values for air, water and a dielectric liquid.

**PROPERTIES:** Prescribed. Air:  $k = 0.026 \text{ W/m}\cdot\text{K}$ ,  $\nu = 1.6 \times 10^{-5} \text{ m}^2/\text{s}$ ,  $\text{Pr} = 0.71$ . Water:  $k = 0.600 \text{ W/m}\cdot\text{K}$ ,  $\nu = 10^{-6} \text{ m}^2/\text{s}$ ,  $\text{Pr} = 5.0$ . Dielectric liquid:  $k = 0.064 \text{ W/m}\cdot\text{K}$ ,  $\nu = 10^{-6} \text{ m}^2/\text{s}$ ,  $\text{Pr} = 25$

**ANALYSIS:** With  $\text{Nu}_L \sim \text{Re}_L^m \text{Pr}^n$ , the convection coefficient may be expressed as

$$h \sim \frac{k}{L} \left( \frac{VL}{\nu} \right)^m \text{Pr}^n \sim \frac{V^m}{L^{1-m}} \left( \frac{k \text{Pr}^n}{\nu^m} \right)$$

The figure of merit is therefore

$$F_F = \frac{k \text{Pr}^n}{\nu^m} \quad <$$

and for the three fluids, with  $m = 0.80$  and  $n = 0.33$ ,

$$F_F \left( \text{W} \cdot \text{s}^{0.8} / \text{m}^{2.6} \cdot \text{K} \right) \quad \begin{array}{ccc} \text{Air} & \text{Water} & \text{Dielectric} \\ \hline 167 & 64,400 & 11,700 \end{array} \quad <$$

Water is clearly the superior heat transfer fluid, while air is the least effective.

**COMMENTS:** The figure of merit indicates that heat transfer is enhanced by fluids of large  $k$ , large  $\text{Pr}$  and small  $\nu$ .

### PROBLEM 6.31

**KNOWN:** Form of the Nusselt number correlation for forced convection and fluid properties. Properties of xenon and He-Xe mixture. Temperature and pressure. Expression for specific heat for monatomic gases.

**FIND:** Figures of merit for air, pure helium, pure xenon, and He-Xe mixture containing 0.75 mole fraction of helium.

**PROPERTIES:** Table A-4, Air (300 K):  $k = 0.0263 \text{ W/m}\cdot\text{K}$ ,  $\nu = 15.89 \times 10^{-6} \text{ m}^2/\text{s}$ ,  $\text{Pr} = 0.707$ . Table A-4, Helium (300 K):  $k = 0.152 \text{ W/m}\cdot\text{K}$ ,  $\nu = 122 \times 10^{-6} \text{ m}^2/\text{s}$ ,  $\text{Pr} = 0.680$ . Pure xenon (given):  $k = 0.006 \text{ W/m}\cdot\text{K}$ ,  $\mu = 24.14 \times 10^{-6} \text{ N}\cdot\text{s/m}^2$ . He-Xe mixture (given):  $k = 0.0713 \text{ W/m}\cdot\text{K}$ ,  $\mu = 25.95 \times 10^{-6} \text{ N}\cdot\text{s/m}^2$ .

**ANALYSIS:** With  $\text{Nu}_L \sim \text{Re}_L^m \text{Pr}^n$ , the convection coefficient may be expressed as

$$h \sim \frac{k}{L} \left( \frac{VL}{\nu} \right)^m \text{Pr}^n \sim \frac{V^m}{L^{1-m}} \left( \frac{k \text{Pr}^n}{\nu^m} \right)$$

The figure of merit is therefore

$$F_F = \frac{k \text{Pr}^n}{\nu^m} \quad (1)$$

For xenon and the He-Xe mixture, we must find the density and specific heat. Proceeding for pure xenon:

$$\rho = \frac{P\mathcal{M}}{\mathfrak{R}T} = \frac{1 \text{ atm} \times 131.29 \text{ kg/kmol}}{8.205 \times 10^{-2} \text{ m}^3 \cdot \text{atm/kmol} \cdot \text{K} \times 300 \text{ K}} = 5.33 \text{ kg/m}^3$$

$$c_p = \frac{5}{2} \frac{\mathfrak{R}}{\mathcal{M}} = \frac{5}{2} \frac{8.315 \times 10^3 \text{ J/kmol} \cdot \text{K}}{131.29 \text{ kg/kmol}} = 158 \text{ J/kg}$$

Thus  $\nu = \mu/\rho = 24.14 \times 10^{-6} \text{ N}\cdot\text{s/m}^2 / 5.33 \text{ kg/m}^3 = 4.53 \times 10^{-6} \text{ m}^2/\text{s}$  and  $\text{Pr} = \mu c_p/k = 24.14 \times 10^{-6} \text{ N}\cdot\text{s/m}^2 \times 158 \text{ J/kg} / 0.006 \text{ W/m}\cdot\text{K} = 0.636$ .

For the He-Xe mixture, the molecular weight of the mixture can be found from

$$\mathcal{M}_{\text{mix}} = 0.75 \text{ kmol He/kmol} \times 4.0 \text{ kg/kmol He} + 0.25 \text{ kmol Xe/kmol} \times 131.29 \text{ kg/kmol Xe} = 35.82 \text{ kg/kmol}$$

from which we can calculate  $\rho = 1.46 \text{ kg/m}^3$ ,  $c_p = 580 \text{ J/kg}\cdot\text{K}$ ,  $\nu = \mu/\rho = 25.95 \times 10^{-6} \text{ N}\cdot\text{s/m}^2 / 1.46 \text{ kg/m}^3 = 1.78 \times 10^{-5} \text{ m}^2/\text{s}$ , and  $\text{Pr} = \mu c_p/k = 25.95 \times 10^{-6} \text{ N}\cdot\text{s/m}^2 \times 580 \text{ J/kg} / 0.0713 \text{ W/m}\cdot\text{K} = 0.211$ .

Finally, for the four fluids, with  $m = 0.85$  and  $n = 0.33$ , we can calculate the figure of merit from Equation (1):

	$F_F \text{ (W}\cdot\text{s}^{0.85}/\text{m}^{2.7}\cdot\text{K)}$	<
Air	281	
Helium	284	
Xenon	180	
He-Xe	465	

**COMMENTS:** The effectiveness of the He-Xe mixture is much higher than that of pure He, pure Xe, or air. By blending He and Xe, the high thermal conductivity of helium and the high density of xenon are both exploited in a manner that leads to a high figure of merit.

### PROBLEM 6.32

**KNOWN:** Local Nusselt number correlation for flow over a roughened surface.

**FIND:** Ratio of average heat transfer coefficient to local coefficient.

**SCHEMATIC:**

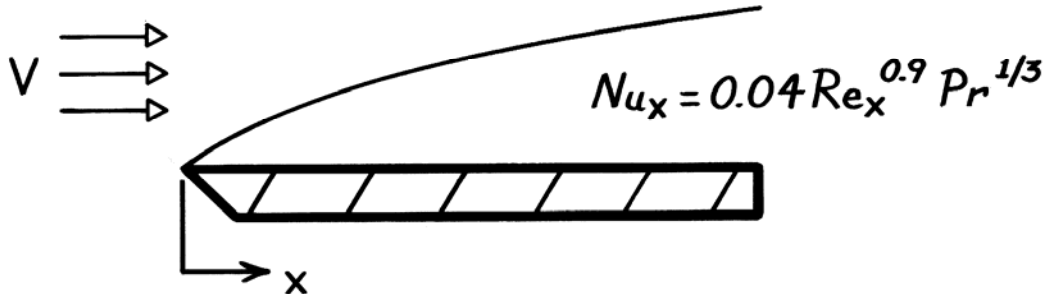

**ANALYSIS:** The local convection coefficient is obtained from the prescribed correlation,

$$h_x = Nu_x \frac{k}{x} = 0.04 \frac{k}{x} Re_x^{0.9} Pr^{1/3}$$

$$h_x = 0.04 k \left[ \frac{V}{\nu} \right]^{0.9} Pr^{1/3} \frac{x^{0.9}}{x} \equiv C_1 x^{-0.1}.$$

To determine the average heat transfer coefficient for the length zero to  $x$ ,

$$\bar{h}_x \equiv \frac{1}{x} \int_0^x h_x dx = \frac{1}{x} C_1 \int_0^x x^{-0.1} dx$$

$$\bar{h}_x = \frac{C_1 x^{0.9}}{x \cdot 0.9} = 1.11 C_1 x^{-0.1}.$$

Hence, the ratio of the average to local coefficient is

$$\frac{\bar{h}_x}{h_x} = \frac{1.11 C_1 x^{-0.1}}{C_1 x^{-0.1}} = 1.11.$$

<

**COMMENTS:** Note that  $\bar{Nu}_x / Nu_x$  is also equal to 1.11. Note, however, that

$$\bar{Nu}_x \neq \frac{1}{x} \int_0^x Nu_x dx.$$

### PROBLEM 6.33

**KNOWN:** Freestream velocity and average convection heat transfer associated with fluid flow over a surface of prescribed characteristic length.

**FIND:** Values of  $\overline{Nu}_L$ ,  $Re_L$ ,  $Pr$ ,  $\overline{j}_H$  for (a) air, (b) engine oil, (c) mercury, (d) water.

**SCHEMATIC:**

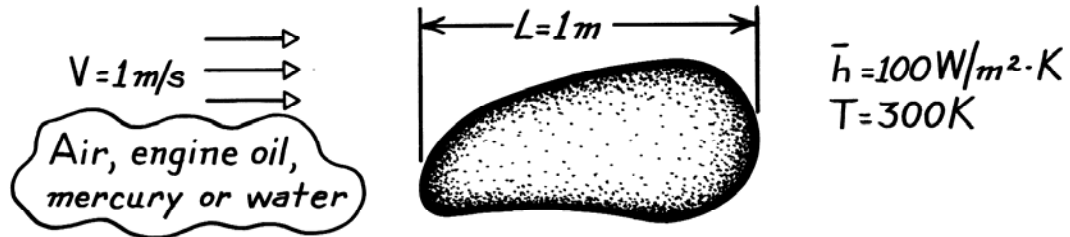

**PROPERTIES:** For the fluids at 300K:

Fluid	Table	$\nu(\text{m}^2/\text{s})$	$k(\text{W}/\text{m}\cdot\text{K})$	$\alpha(\text{m}^2/\text{s})$	Pr
Air	A.4	$15.89 \times 10^{-6}$	0.0263	$22.5 \times 10^{-7}$	0.71
Engine Oil	A.5	$550 \times 10^{-6}$	0.145	$0.859 \times 10^{-7}$	6400
Mercury	A.5	$0.113 \times 10^{-6}$	8.54	$45.30 \times 10^{-7}$	0.025
Water	A.6	$0.858 \times 10^{-6}$	0.613	$1.47 \times 10^{-7}$	5.83

**ANALYSIS:** The appropriate relations required are

$$\overline{Nu}_L = \frac{\overline{h}L}{k} \quad Re_L = \frac{VL}{\nu} \quad Pr = \frac{\nu}{\alpha} \quad \overline{j}_H = \overline{St}Pr^{2/3} \quad \overline{St} = \frac{\overline{Nu}_L}{Re_L Pr}$$

Fluid	$\overline{Nu}_L$	$Re_L$	Pr	$\overline{j}_H$	<
Air	3802	$6.29 \times 10^4$	0.71	0.068	
Engine Oil	690	$1.82 \times 10^3$	6403	0.0204	
Mercury	11.7	$8.85 \times 10^6$	0.025	$4.52 \times 10^{-6}$	
Water	163	$1.17 \times 10^6$	5.84	$7.74 \times 10^{-5}$	

**COMMENTS:** Note the wide range of Pr associated with the fluids.

## PROBLEM 6.34

**KNOWN:** Base fluid (water) and nanofluid properties. Fixed surface and ambient temperatures, fixed characteristic velocity. Fixed geometry. Form of Nusselt number correlation.

**FIND:** (a) Prandtl numbers of the base fluid and nanofluid. (b) Ratio of Reynolds numbers of the two fluids and ratio of Nusselt numbers necessary to provide the same convection heat transfer coefficients. (c) Whether the base fluid can provide greater convection heat transfer rates than the nanofluid.

**SCHEMATIC:**

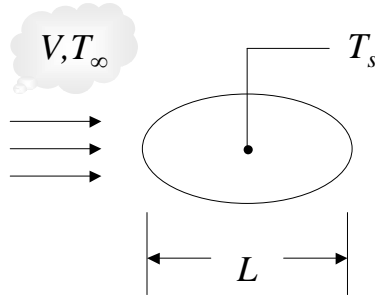

**ASSUMPTIONS:** (1) Steady-state conditions, (2) Constant properties, (3) Negligible viscous dissipation.

**PROPERTIES:** Table A.6 ( $T = 300 \text{ K}$ ): Water;  $k_{bf} = 0.613 \text{ W/m}\cdot\text{K}$ ,  $\rho_{bf} = 997 \text{ kg/m}^3$ ,  $c_{p,bf} = 4.179 \text{ kJ/kg}\cdot\text{K}$ ,  $\mu_{bf} = 855 \times 10^{-6} \text{ N}\cdot\text{s/m}^2$ . Example 2.2: Nanofluid,  $k_{nf} = 0.705 \text{ W/m}\cdot\text{K}$ ,  $\rho_{nf} = 1146 \text{ kg/m}^3$ ,  $c_{p,nf} = 3.587 \text{ kJ/kg}\cdot\text{K}$ ,  $\mu_{nf} = 962 \times 10^{-6} \text{ N}\cdot\text{s/m}^2$ .

**ANALYSIS:** (a) The Prandtl numbers for the water and nanofluid are:

$$Pr_{bf} = \frac{\mu_{bf} c_{p,bf}}{k_{bf}} = \frac{855 \times 10^{-6} \text{ N}\cdot\text{s/m}^2 \times 4179 \text{ J/kg}\cdot\text{K}}{0.613 \text{ W/m}\cdot\text{K}} = 5.83 \quad <$$

$$Pr_{nf} = \frac{\mu_{nf} c_{p,nf}}{k_{nf}} = \frac{962 \times 10^{-6} \text{ N}\cdot\text{s/m}^2 \times 3587 \text{ J/kg}\cdot\text{K}}{0.705 \text{ W/m}\cdot\text{K}} = 4.89 \quad <$$

(b) For a given velocity and characteristic length,

$$\frac{Re_{nf}}{Re_{bf}} = \frac{\rho_{nf} \mu_{bf}}{\rho_{bf} \mu_{nf}} = \frac{1146 \text{ kg/m}^3 \times 855 \times 10^{-6} \text{ N}\cdot\text{s/m}^2}{997 \text{ kg/m}^3 \times 962 \times 10^{-6} \text{ N}\cdot\text{s/m}^2} = 1.022 \quad <$$

For the same convection heat transfer coefficients,

$$\frac{\bar{h}_{nf}}{\bar{h}_{bf}} = 1 = \frac{\bar{Nu}_{nf} k_{nf} L_{bf}}{\bar{Nu}_{bf} k_{bf} L_{nf}} \quad \text{or} \quad \frac{\bar{Nu}_{nf}}{\bar{Nu}_{bf}} = \frac{k_{bf}}{k_{nf}} = \frac{0.613 \text{ W/m}\cdot\text{K}}{0.705 \text{ W/m}\cdot\text{K}} = 0.870 \quad <$$

(c) For the base fluid to have a greater convection heat transfer rate would require  $\bar{h}_{bf} > \bar{h}_{nf}$ , or

$\bar{Nu}_{bf} > \frac{1}{0.870} \bar{Nu}_{nf}$ . Using the relationship provided in the problem statement,

$C Re_{bf}^m Pr_{bf}^{1/3} > \frac{C}{0.870} Re_{nf}^n Pr_{nf}^{1/3}$  which may be rearranged to yield

Continued...



### PROBLEM 6.34 (Cont.)

$$\left(\frac{Re_{nf}}{Re_{bf}}\right)^m < 0.870 \left(\frac{Pr_{bf}}{Pr_{nf}}\right)^{1/3} = 0.870 \left(\frac{5.83}{4.92}\right)^{1/3} = 0.921$$

Since  $(Re_{nf}/Re_{bf}) > 1$  and  $m > 1$ , the equation cannot be satisfied. Therefore we conclude that the base fluid would not provide greater convection heat transfer rates than the nanofluid as long as  $m$  is positive. <

**COMMENTS:** (1) The conclusion regarding the relative efficacy of the nanofluid to the base fluid is valid only for situations involving unconstrained boundary layers. (2) For internal flow situations, such as will be discussed in Chapter 8, one cannot draw a general conclusion that the nanofluid would outperform the base fluid. In fact, in common instances, the base fluid would outperform the nanofluid.

**PROBLEM 6.35**

**KNOWN:** Variation of  $h_x$  with  $x$  for flow over a flat plate.

**FIND:** Ratio of average Nusselt number for the entire plate to the local Nusselt number at  $x = L$ .

**SCHEMATIC:**

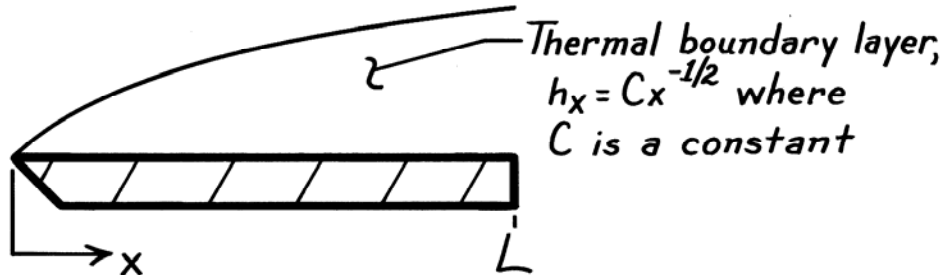

**ANALYSIS:** The expressions for the local and average Nusselt numbers are

$$Nu_L = \frac{h_L L}{k} = \frac{(CL^{-1/2})L}{k} = \frac{CL^{1/2}}{k}$$

$$\overline{Nu}_L = \frac{\overline{h}_L L}{k}$$

where

$$\overline{h}_L = \frac{1}{L} \int_0^L h_x dx = \frac{C}{L} \int_0^L x^{-1/2} dx = \frac{2C}{L} L^{1/2} = 2 CL^{-1/2}.$$

Hence,

$$\overline{Nu}_L = \frac{2 CL^{-1/2} (L)}{k} = \frac{2 CL^{1/2}}{k}$$

and

$$\frac{\overline{Nu}_L}{Nu_L} = 2.$$

**COMMENTS:** Note the manner in which  $\overline{Nu}_L$  is defined in terms of  $\overline{h}_L$ . Also note that

$$\overline{Nu}_L \neq \frac{1}{L} \int_0^L Nu_x dx.$$

### PROBLEM 6.36

**KNOWN:** Laminar boundary layer flow of air at 20°C and 1 atm having  $\delta_t = 1.13 \delta$ .

**FIND:** Ratio  $\delta / \delta_t$  when fluid is ethylene glycol for same conditions.

**SCHEMATIC:**

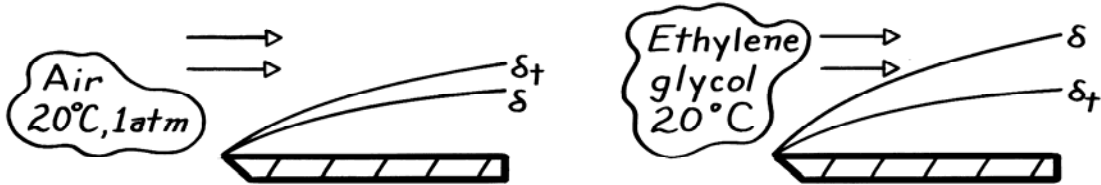

**ASSUMPTIONS:** (1) Laminar flow.

**PROPERTIES:** Table A-4, Air (293K, 1 atm):  $Pr = 0.709$ ; Table A-5, Ethylene glycol (293K):  $Pr = 211$ .

**ANALYSIS:** The Prandtl number strongly influences relative growth of the velocity,  $\delta$ , and thermal,  $\delta_t$ , boundary layers. For laminar flow, the approximate relationship is given by

$$Pr^n \approx \frac{\delta}{\delta_t}$$

where  $n$  is a positive coefficient. Substituting the values for air

$$(0.709)^n = \frac{1}{1.13}$$

find that  $n = 0.355$ . Hence, for ethylene glycol it follows that

$$\frac{\delta}{\delta_t} = Pr^{0.355} = 211^{0.355} = 6.69.$$

<

**COMMENTS:** (1) For laminar flow, generally we find  $n = 0.33$ . In which case,  $\delta / \delta_t = 5.85$ .

(2) Recognize the physical importance of  $\nu > \alpha$ , which gives large values of the Prandtl number, and causes  $\delta > \delta_t$ .

### PROBLEM 6.37

**KNOWN:** Air, water, engine oil or mercury at 300K in laminar, parallel flow over a flat plate.

**FIND:** Sketch of velocity and thermal boundary layer thickness.

**ASSUMPTIONS:** (1) Laminar flow.

**PROPERTIES:** For the fluids at 300K:

Fluid	Table	Pr
Air	A.4	0.71
Water	A.6	5.83
Engine Oil	A.5	6400
Mercury	A.5	0.025

**ANALYSIS:** For laminar, boundary layer flow over a flat plate.

$$\frac{\delta}{\delta_t} \sim Pr^n$$

where  $n > 0$ . Hence, the boundary layers appear as shown below.

Air:

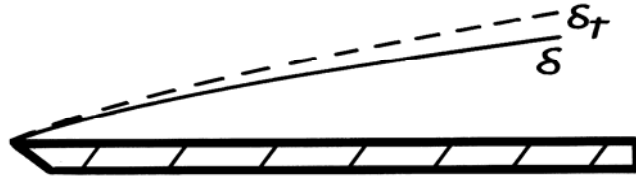

Water:

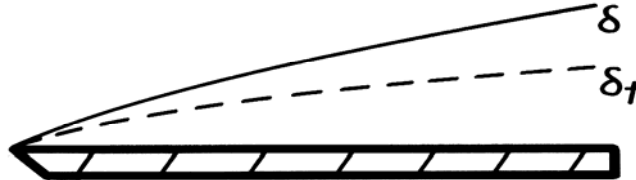

Engine Oil:

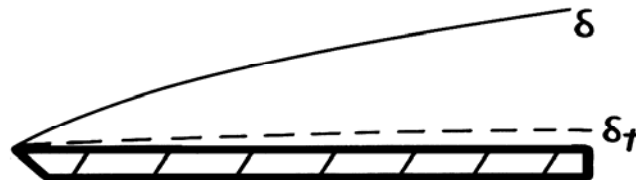

Mercury:

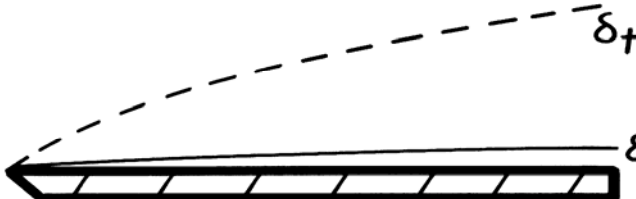

**COMMENTS:** Although Pr strongly influences relative boundary layer development in laminar flow, its influence is weak for turbulent flow.

### PROBLEM 6.38

**KNOWN:** Flow over a flat plate. Velocity and temperature of two fluids. Variation of boundary layer thickness with  $x$  for laminar flow.

**FIND:** (a) Location where transition to turbulence occurs for each fluid, (b) Plot of velocity boundary layer thickness for  $0 \leq x \leq x_c$  for each fluid, (c) Plot of thermal boundary layer thickness over the same range. Which fluid has the largest local temperature gradient at the surface, Nusselt number, and heat transfer coefficient.

**SCHEMATIC:**

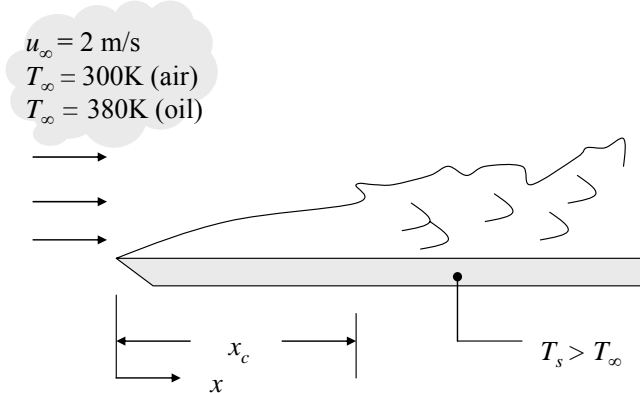

**ASSUMPTIONS:** (1) Steady-state conditions, (2) Incompressible flow, (3) Transition occurs at a critical Reynolds number of  $5 \times 10^5$ .

**PROPERTIES:** Table A.4, Air ( $T = 300 \text{ K}$ ):  $\nu = 15.89 \times 10^{-6} \text{ m}^2/\text{s}$ ,  $k = 0.0263 \text{ W/m}\cdot\text{K}$ ,  $Pr = 0.707$ .  
Table A.5, Engine Oil ( $T = 380 \text{ K}$ ):  $\nu = 16.9 \times 10^{-6} \text{ m}^2/\text{s}$ ,  $k = 0.136 \text{ W/m}\cdot\text{K}$ ,  $Pr = 233$ .

**ANALYSIS:** (a) Transition occurs at  $Re_{x,c} = u_\infty x / \nu = 5 \times 10^5$ . Therefore, for air

$$x_c = 5 \times 10^5 \frac{\nu}{u_\infty} = 5 \times 10^5 \frac{15.89 \times 10^{-6} \text{ m}^2/\text{s}}{2 \text{ m/s}} = 4.0 \text{ m} \quad <$$

The value for engine oil is 4.2 m. <

(b) The velocity boundary layer thickness is given by  $\frac{\delta}{x} = \frac{5}{\sqrt{Re_x}}$ . Thus, for air

$$\delta = \frac{5x}{\sqrt{Re_x}} = 5\sqrt{x\nu/u_\infty} = 5\sqrt{\frac{15.89 \times 10^{-6} \text{ m}^2/\text{s} \times x}{2 \text{ m/s}}} = 0.0141x^{1/2} \quad <$$

where  $x$  and  $\delta$  are expressed in meters. The corresponding result for engine oil is  $\delta = 0.0145x^{1/2}$ . <

These results are plotted below.

Continued...

### PROBLEM 6.38 (Cont.)

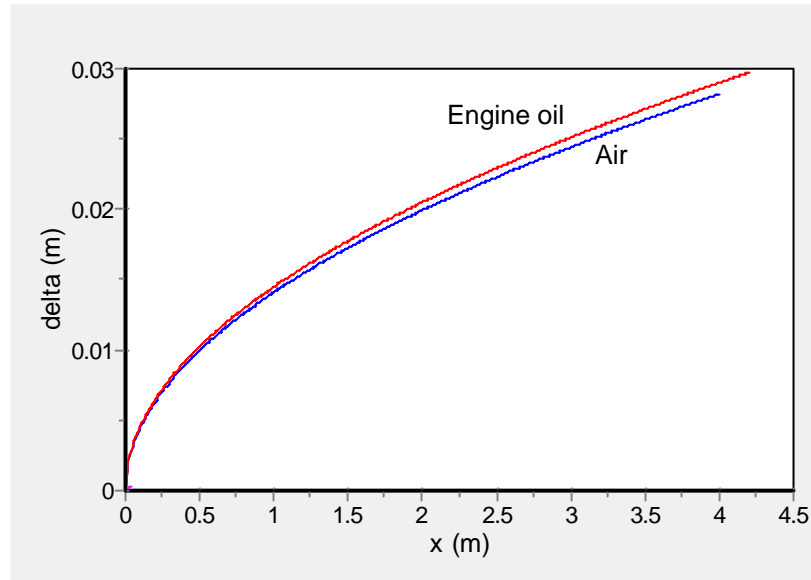

&lt;

(c) From Eq. 6.55 with  $n = 1/3$ ,  $\delta_i = \delta Pr^{-1/3}$ . Thus, for air

$$\delta_i = \delta Pr^{-1/3} = 0.0141x^{1/2} \times (0.707)^{-1/3} = 0.0158x^{1/2}$$

&lt;

Similarly for engine oil  $\delta_i = 0.00586x^{1/2}$ .

&lt;

The results for the two fluids are shown below.

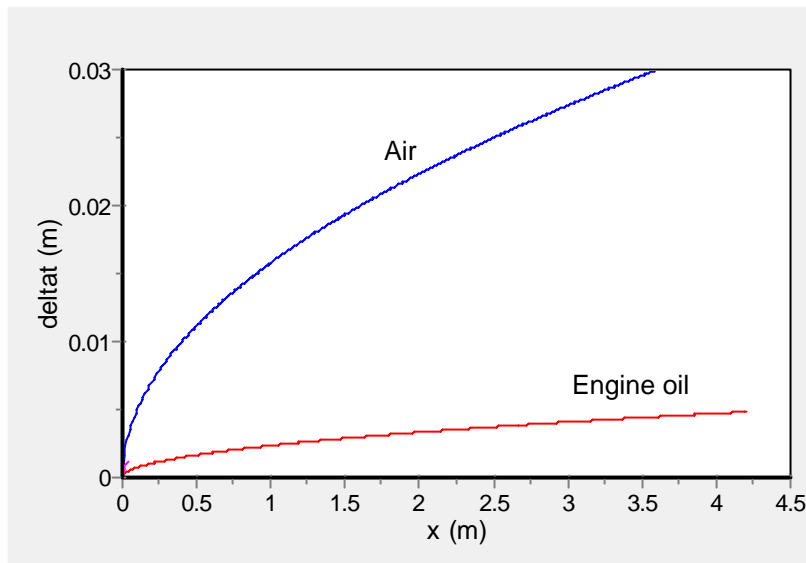

&lt;

Continued...

### PROBLEM 6.38 (Cont.)

The two fluids are subjected to the same temperature difference between the surface and the free stream. Since the thermal boundary layer thickness is the distance over which the temperature varies from the surface temperature to the free stream temperature, the fluid with the smaller value of  $\delta_t$  must have a larger temperature gradient,  $-\partial T/\partial y|_{y=0}$ .

Therefore, engine oil has the larger temperature gradient at the surface. <

The local Nusselt number is given by  $Nu = hx/k$ , where  $h$  is defined in Equation 6.5. Therefore,

$$Nu = \frac{-\partial T / \partial y|_{y=0}}{T_s - T_\infty} x$$

At a given  $x$  location, since  $T_s - T_\infty$  is the same for both fluids, the fluid with the larger temperature gradient has the larger local Nusselt number.

Engine oil has the larger local Nusselt number. <

The heat transfer coefficient is given by Equation 6.5:

$$h = \frac{-k_f \partial T / \partial y|_{y=0}}{T_s - T_\infty}$$

Since engine oil has a larger temperature gradient *and* a larger thermal conductivity, it is associated with a larger heat transfer coefficient. <

**COMMENTS:** (1) Since the kinematic viscosity of the two fluids is nearly the same, their local Reynolds numbers, transition locations, and velocity boundary layer thicknesses are comparable. (2) The much higher Prandtl number of the engine oil results in a much thinner thermal boundary layer and consequently a larger temperature gradient at the surface and higher heat transfer coefficient.

### PROBLEM 6.39

**KNOWN:** Expression for the local heat transfer coefficient of air at prescribed velocity and temperature flowing over electronic elements on a circuit board and heat dissipation rate for a  $4 \times 4$  mm chip located 120mm from the leading edge.

**FIND:** Surface temperature of the chip surface,  $T_s$ .

**SCHEMATIC:**

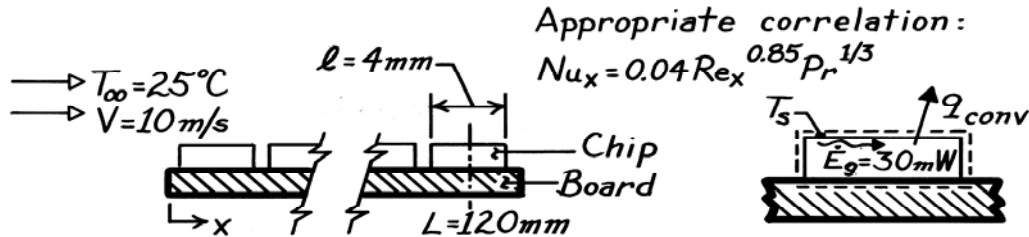

**ASSUMPTIONS:** (1) Steady-state conditions, (2) Power dissipated within chip is lost by convection across the upper surface only, (3) Chip surface is isothermal, (4) The average heat transfer coefficient for the chip surface is equivalent to the local value at  $x = L$ , (5) Negligible radiation.

**PROPERTIES:** Table A-4, Air (assume  $T_s = 45^\circ\text{C}$ ,  $T_f = (45 + 25)/2 = 35^\circ\text{C} = 308\text{K}$ , 1atm):  $\nu = 16.69 \times 10^{-6} \text{ m}^2/\text{s}$ ,  $k = 26.9 \times 10^{-3} \text{ W/m}\cdot\text{K}$ ,  $\text{Pr} = 0.703$ .

**ANALYSIS:** From an energy balance on the chip (see above),

$$q_{\text{conv}} = \dot{E}_g = 30\text{W}. \quad (1)$$

Newton's law of cooling for the upper chip surface can be written as

$$T_s = T_\infty + q_{\text{conv}} / \bar{h} A_{\text{chip}} \quad (2)$$

where  $A_{\text{chip}} = \ell^2$ . Assume that the *average* heat transfer coefficient ( $\bar{h}$ ) over the chip surface is equivalent to the *local* coefficient evaluated at  $x = L$ . That is,  $\bar{h}_{\text{chip}} \approx h_x(L)$  where the local coefficient can be evaluated from the special correlation for this situation,

$$\text{Nu}_x = \frac{h_x x}{k} = 0.04 \left[ \frac{Vx}{\nu} \right]^{0.85} \text{Pr}^{1/3}$$

and substituting numerical values with  $x = L$ , find

$$h_x = 0.04 \frac{k}{L} \left[ \frac{VL}{\nu} \right]^{0.85} \text{Pr}^{1/3}$$

$$h_x = 0.04 \left[ \frac{0.0269 \text{ W/m}\cdot\text{K}}{0.120 \text{ m}} \right] \left[ \frac{10 \text{ m/s} \times 0.120 \text{ m}}{16.69 \times 10^{-6} \text{ m}^2/\text{s}} \right]^{0.85} (0.703)^{1/3} = 107 \text{ W/m}^2 \cdot \text{K}.$$

The surface temperature of the chip is from Eq. (2),

$$T_s = 25^\circ\text{C} + 30 \times 10^{-3} \text{ W} / \left[ 107 \text{ W/m}^2 \cdot \text{K} \times (0.004\text{m})^2 \right] = 42.5^\circ\text{C}. \quad <$$

**COMMENTS:** (1) Note that the estimated value for  $T_f$  used to evaluate the air properties was reasonable. (2) Alternatively, we could have evaluated  $\bar{h}_{\text{chip}}$  by performing the integration of the local value,  $h(x)$ .



## PROBLEM 6.40

**KNOWN:** Expression for the local heat transfer coefficient of air at prescribed velocity and temperature flowing over electronic elements on a circuit board and heat dissipation rate for a 4 × 4 mm chip located 120 mm from the leading edge. Atmospheric pressure in Mexico City.

**FIND:** (a) Surface temperature of chip, (b) Air velocity required for chip temperature to be the same at sea level.

**SCHEMATIC:**

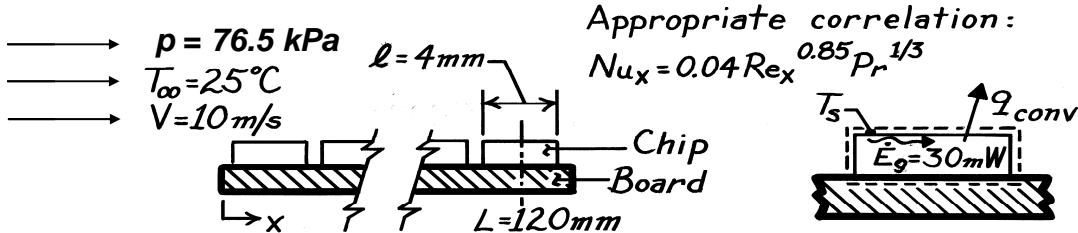

**ASSUMPTIONS:** (1) Steady-state conditions, (2) Power dissipated in chip is lost by convection across the upper surface only, (3) Chip surface is isothermal, (4) The average heat transfer coefficient for the chip surface is equivalent to the local value at  $x = L$ , (5) Negligible radiation, (6) Ideal gas behavior.

**PROPERTIES:** Table A.4, air ( $p = 1 \text{ atm}$ , assume  $T_s = 45 \text{ }^\circ\text{C}$ ,  $T_f = (45 \text{ }^\circ\text{C} + 25 \text{ }^\circ\text{C})/2 = 35 \text{ }^\circ\text{C}$ ):  $k = 0.0269 \text{ W/m}\cdot\text{K}$ ,  $\nu = 16.69 \times 10^{-6} \text{ m}^2/\text{s}$ ,  $Pr = 0.706$ .

**ANALYSIS:**

(a) From an energy balance on the chip (see above),

$$q_{\text{conv}} = \dot{E}_g = 30 \text{ W.} \quad (1)$$

Newton's law of cooling for the upper chip surface can be written as

$$T_s = T_\infty + q_{\text{conv}} / \bar{h} A_{\text{chip}} \quad (2)$$

where  $A_{\text{chip}} = \ell^2$ . From Assumption 4,  $\bar{h}_{\text{chip}} \approx h_x(L)$  where the local coefficient can be evaluated from the correlation provided in Problem 6.35.

$$Nu_x = \frac{h_x x}{k} = 0.04 \left[ \frac{Vx}{\nu} \right]^{0.85} Pr^{1/3} \quad (3)$$

The kinematic viscosity is

$$\nu = \frac{\mu}{\rho} \quad (4)$$

while for an ideal gas,

$$\rho = \frac{p}{RT} \quad (5)$$

Combining Equations 4 and 5 yields

$$\nu \propto p^{-1} \quad (6)$$

Continued...

### PROBLEM 6.40 (Cont.)

The Prandtl number is

$$Pr = \frac{\nu}{\alpha} = \frac{\mu\rho c}{\rho k} = \frac{\mu c}{k} \quad (7)$$

which is independent of pressure.

Therefore, at sea level ( $p = 1 \text{ atm}$ )

$$k = 0.0269 \text{ W/m}\cdot\text{K}, \quad \nu = 16.69 \times 10^{-6} \text{ m}^2/\text{s}, \quad Pr = 0.706$$

$$h_x = 0.04 \frac{k}{L} \left[ \frac{VL}{\nu} \right]^{0.85} Pr^{1/3}$$

$$h_x = 0.04 \left[ \frac{0.0269 \text{ W/m}\cdot\text{K}}{0.120 \text{ m}} \right] \left[ \frac{10 \text{ m/s} \times 0.120 \text{ m}}{16.69 \times 10^{-6} \text{ m}^2/\text{s}} \right]^{0.85} (0.706)^{1/3} = 107 \text{ W/m}^2 \cdot \text{K}$$

$$T_s = 25^\circ\text{C} + 30 \times 10^{-3} \text{ W} / \left[ 107 \text{ W/m}^2 \cdot \text{K} \times (0.004 \text{ m})^2 \right] = 42.5^\circ\text{C}$$

In Mexico City ( $p = 76.5 \text{ kPa}$ )

$$\nu = 16.69 \times 10^{-6} \text{ m}^2/\text{s} \times \left[ \frac{101.3 \text{ kPa}}{76.5 \text{ kPa}} \right] = 22.10 \times 10^{-6} \text{ m}^2/\text{s}$$

$$k = 0.0269 \text{ W/m}\cdot\text{K}, \quad Pr = 0.706$$

$$h_x = 0.04 \left[ \frac{0.0269 \text{ W/m}\cdot\text{K}}{0.120 \text{ m}} \right] \left[ \frac{10 \text{ m/s} \times 0.120 \text{ m}}{22.10 \times 10^{-6} \text{ m}^2/\text{s}} \right]^{0.85} (0.706)^{1/3} = 84.5 \text{ W/m}^2 \cdot \text{K}$$

$$T_s = 25^\circ\text{C} + 30 \times 10^{-3} \text{ W} / \left[ 84.5 \text{ W/m}^2 \cdot \text{K} \times (0.004 \text{ m})^2 \right] = 47.2^\circ\text{C} \quad <$$

(b) For the same chip temperature, it is required that  $h_x = 107 \text{ W/m}^2\cdot\text{K}$ . Therefore

$$h_x = 107 \text{ W/m}^2 \cdot \text{K} = 0.04 \left[ \frac{0.0269 \text{ W/m}\cdot\text{K}}{0.120 \text{ m}} \right] \left[ \frac{V \times 0.120 \text{ m}}{22.10 \times 10^{-6} \text{ m}^2/\text{s}} \right]^{0.85} (0.706)^{1/3}$$

From which we may find  $V = 13.2 \text{ m/s}$  <

**COMMENTS:** (1) In Part (a), the chip surface temperature increased from  $42.4^\circ\text{C}$  to  $47.2^\circ\text{C}$ . This is considered to be significant and the electronics packaging engineer needs to consider the effect of large changes in atmospheric pressure on the efficacy of the electronics cooling scheme. (2) Careful consideration needs to be given to the effect changes in the atmospheric pressure on the kinematic viscosity and, in turn, on changes in transition lengths which might affect local convective heat transfer coefficients.

## PROBLEM 6.41

**KNOWN:** Location and dimensions of computer chip on a circuit board. Form of the convection correlation. Maximum allowable chip temperature and surface emissivity. Temperature of cooling air and surroundings.

**FIND:** Effect of air velocity on maximum power dissipation, first without and then with consideration of radiation effects.

**SCHEMATIC:**

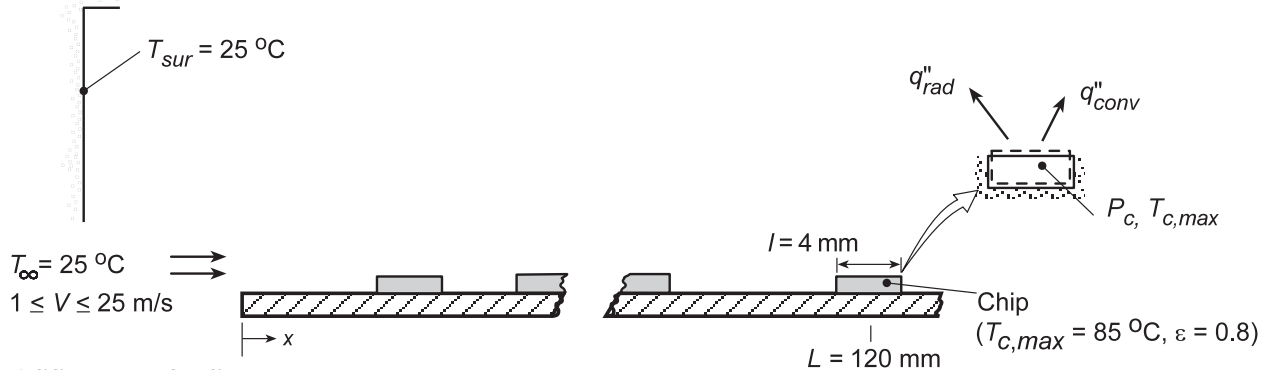

**ASSUMPTIONS:** (1) Steady-state, (2) Negligible temperature variations in chip, (3) Heat transfer exclusively from the top surface of the chip, (4) The local heat transfer coefficient at  $x = L$  provides a good approximation to the average heat transfer coefficient for the chip surface.

**PROPERTIES:** Table A.4, air ( $\bar{T} = (T_\infty + T_c)/2 = 328 \text{ K}$ ):  $\nu = 18.71 \times 10^{-6} \text{ m}^2/\text{s}$ ,  $k = 0.0284 \text{ W/m}\cdot\text{K}$ ,  $\text{Pr} = 0.703$ .

**ANALYSIS:** Performing an energy balance for a control surface about the chip, we obtain  $P_c = q_{\text{conv}} + q_{\text{rad}}$ , where  $q_{\text{conv}} = \bar{h}A_s(T_c - T_\infty)$ ,  $q_{\text{rad}} = h_r A_s(T_c - T_{\text{sur}})$ , and  $h_r = \varepsilon\sigma(T_c + T_{\text{sur}})(T_c^2 + T_{\text{sur}}^2)$ . With  $\bar{h} \approx h_L$ , the convection coefficient may be determined from the correlation provided in Problem 6.39 ( $\text{Nu}_L = 0.04 \text{ Re}_L^{0.85} \text{ Pr}^{1/3}$ ). Hence,

$$P_c = \ell^2 \left[ 0.04(k/L) \text{Re}_L^{0.85} \text{Pr}^{1/3} (T_c - T_\infty) + \varepsilon\sigma(T_c + T_{\text{sur}})(T_c^2 + T_{\text{sur}}^2)(T_c - T_{\text{sur}}) \right]$$

where  $\text{Re}_L = VL/\nu$ . Computing the right side of this expression for  $\varepsilon = 0$  and  $\varepsilon = 0.85$ , we obtain the following results.

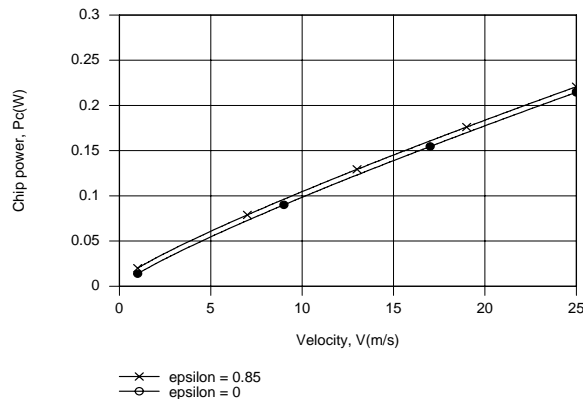

Since  $h_L$  increases as  $V^{0.85}$ , the chip power must increase with  $V$  in the same manner. Radiation exchange increases  $P_c$  by a fixed, but small (6 mW) amount. While  $h_L$  varies from 14.5 to 223  $\text{W/m}^2\cdot\text{K}$  over the prescribed velocity range,  $h_r = 6.5 \text{ W/m}^2\cdot\text{K}$  is a constant, independent of  $V$ .

**COMMENTS:** Alternatively,  $\bar{h}$  could have been evaluated by integrating  $h_x$  over the range  $118 \leq x \leq 122 \text{ mm}$  to obtain the appropriate average. However, the value would be extremely close to  $h_{x=L}$ .

### PROBLEM 6.42

**KNOWN:** Form of Nusselt number for flow of air or a dielectric liquid over components of a circuit card.

**FIND:** Ratios of time constants associated with intermittent heating and cooling. Fluid that provides faster thermal response.

**PROPERTIES:** Prescribed. Air:  $k = 0.026 \text{ W/m}\cdot\text{K}$ ,  $\nu = 2 \times 10^{-5} \text{ m}^2/\text{s}$ ,  $\text{Pr} = 0.71$ . Dielectric liquid:  $k = 0.064 \text{ W/m}\cdot\text{K}$ ,  $\nu = 10^{-6} \text{ m}^2/\text{s}$ ,  $\text{Pr} = 25$ .

**ANALYSIS:** From Eq. 5.7, the thermal time constant is

$$\tau_t = \frac{\rho \nabla c}{\bar{h} A_s}$$

Since the only variable that changes with the fluid is the convection coefficient, where

$$\bar{h} = \frac{k}{L} \overline{\text{Nu}}_L = \frac{k}{L} C \text{Re}_L^m \text{Pr}^n = \frac{k}{L} C \left( \frac{VL}{\nu} \right)^m \text{Pr}^n$$

the desired ratio reduces to

$$\frac{\tau_{t,\text{air(a)}}}{\tau_{t,\text{dielectric(d)}}} = \frac{\bar{h}_d}{\bar{h}_a} = \frac{k_d}{k_a} \left( \frac{\nu_a}{\nu_d} \right)^m \left( \frac{\text{Pr}_d}{\text{Pr}_a} \right)^n$$

$$\frac{\tau_{t,a}}{\tau_{t,d}} = \frac{0.064}{0.026} \left( \frac{2 \times 10^{-5}}{10^{-6}} \right)^{0.8} \left( \frac{25}{0.71} \right)^{0.33} = 88.6$$

Since its time constant is nearly two orders of magnitude smaller than that of the air, the dielectric liquid is clearly the fluid of choice. <

**COMMENTS:** The accelerated testing procedure suggested by this problem is commonly used to test the durability of electronic packages.

### PROBLEM 6.43

**KNOWN:** Ambient, interior and dewpoint temperatures. Vehicle speed and dimensions of windshield. Heat transfer correlation for external flow.

**FIND:** Minimum value of convection coefficient needed to prevent condensation on interior surface of windshield.

**SCHEMATIC:**

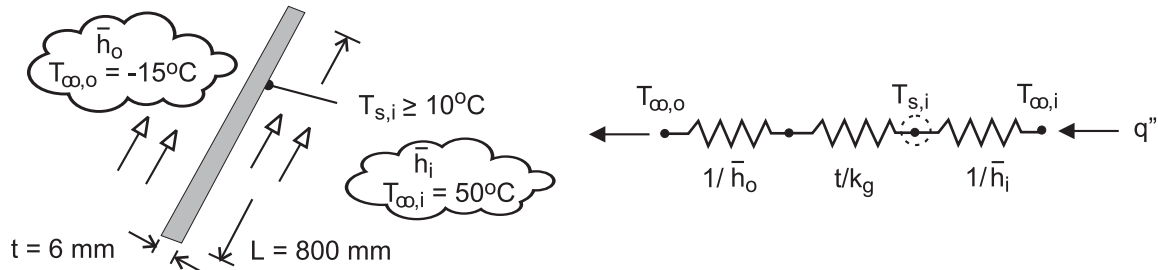

**ASSUMPTIONS:** (1) Steady-state, (2) One-dimensional heat transfer, (3) Constant properties.

**PROPERTIES:** Table A-3, glass:  $k_g = 1.4 \text{ W/m}\cdot\text{K}$ . Prescribed, air:  $k = 0.023 \text{ W/m}\cdot\text{K}$ ,  $\nu = 12.5 \times 10^{-6} \text{ m}^2/\text{s}$ ,  $\text{Pr} = 0.70$ .

**ANALYSIS:** From the prescribed thermal circuit, conservation of energy yields

$$\frac{T_{\infty,i} - T_{s,i}}{1/\bar{h}_i} = \frac{T_{s,i} - T_{\infty,o}}{t/k_g + 1/\bar{h}_o}$$

where  $\bar{h}_o$  may be obtained from the correlation

$$\text{Nu}_L = \frac{\bar{h}_o L}{k} = 0.030 \text{Re}_L^{0.8} \text{Pr}^{1/3}$$

With  $V = (70 \text{ mph} \times 1585 \text{ m/mile})/3600 \text{ s/h} = 30.8 \text{ m/s}$ ,  $\text{Re}_D = (30.8 \text{ m/s} \times 0.800 \text{ m})/12.5 \times 10^{-6} \text{ m}^2/\text{s} = 1.97 \times 10^6$  and

$$\bar{h}_o = \frac{0.023 \text{ W/m}\cdot\text{K}}{0.800 \text{ m}} 0.030 (1.97 \times 10^6)^{0.8} (0.70)^{1/3} = 83.1 \text{ W/m}^2 \cdot \text{K}$$

From the energy balance, with  $T_{s,i} = T_{\text{dp}} = 10^\circ\text{C}$

$$\bar{h}_i = \frac{(T_{s,i} - T_{\infty,o})}{(T_{\infty,i} - T_{s,i})} \left( \frac{t}{k_g} + \frac{1}{\bar{h}_o} \right)^{-1}$$

$$\bar{h}_i = \frac{(10 + 15)^\circ\text{C}}{(50 - 10)^\circ\text{C}} \left( \frac{0.006 \text{ m}}{1.4 \text{ W/m}\cdot\text{K}} + \frac{1}{83.1 \text{ W/m}^2 \cdot \text{K}} \right)^{-1}$$

$$\bar{h}_i = 38.3 \text{ W/m}^2 \cdot \text{K} \quad \leftarrow$$

**COMMENTS:** The output of the fan in the automobile's heater/defroster system must maintain a velocity for flow over the inner surface that is large enough to provide the foregoing value of  $\bar{h}_i$ . In addition, the output of the heater must be sufficient to maintain the prescribed value of  $T_{\infty,i}$  at this velocity.

## PROBLEM 6.44

**KNOWN:** Characteristic length of a microscale chemical detector, free stream velocity and temperature, hydrogen wind tunnel pressure and free stream velocity.

**FIND:** Model length scale and hydrogen temperature needed for similarity.

**SCHEMATIC:**

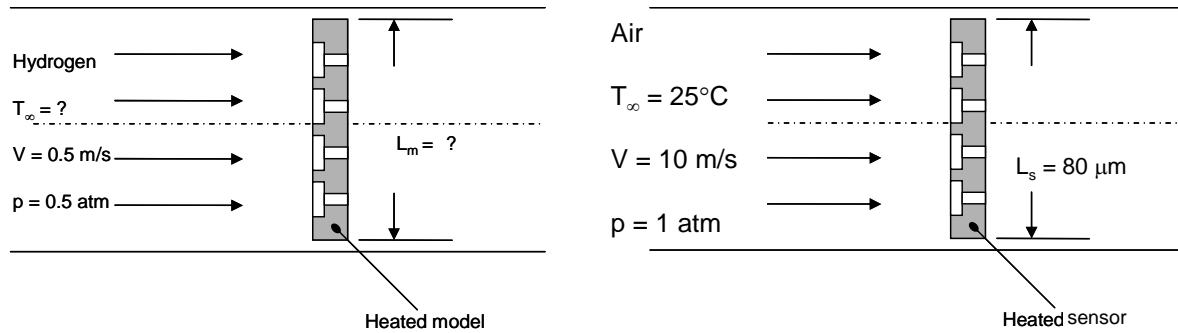

**ASSUMPTIONS:** (1) Steady-state conditions, (2) Constant properties, (3) Negligible microscale or nanoscale effects, (4) Ideal gas behavior.

**PROPERTIES:** Table A.4, air ( $T = 25^\circ\text{C}$ ):  $Pr_s = 0.707$ ,  $\nu_s = 15.71 \times 10^{-6} \text{ m}^2/\text{s}$ , hydrogen (250 K)  $Pr = 0.707$ ,  $\nu = 81.4 \times 10^{-6} \text{ m}^2/\text{s}$ .

**ANALYSIS:** For similarity we require  $Re_m = Re_s$  and  $Pr_m = Pr_s$ . For the sensor,

$$Re_s = \frac{V_s L_s}{\nu_s} = \frac{10 \text{ m/s} \times 80 \times 10^{-6} \text{ m}}{1.571 \times 10^{-5} \text{ m}^2/\text{s}} = 50.93$$

$$Pr_s = 0.707$$

For the model,  $Pr_m = Pr_s = 0.707$ .

From Table A.4, we note  $Pr_s = 0.707$ ,  $\nu = 81.4 \times 10^{-6} \text{ m}^2/\text{s}$  at  $T_\infty = 250 \text{ K}$  and  $p = 1 \text{ atm}$ . <

The value of the Prandtl number is independent of pressure for an ideal gas. The kinematic viscosity is pressure-dependent. Hence,

$$\nu(\text{at } 0.5 \text{ atm}) = \frac{\mu}{\rho(\text{at } 0.5 \text{ atm})} = \frac{\mu}{\rho(\text{at } 1.0 \text{ atm})} \times \frac{\rho(\text{at } 1.0 \text{ atm})}{\rho(\text{at } 0.5 \text{ atm})}$$

For an ideal gas,

$$\nu(\text{at } 0.5 \text{ atm}) = \nu(\text{at } 1.0 \text{ atm}) \times \frac{1.0 \text{ atm}}{0.5 \text{ atm}} = 2\nu(\text{at } 1.0 \text{ atm})$$

Therefore,

$$\nu_m = 81.4 \times 10^{-6} \text{ m}^2/\text{s} \times 2 = 163 \times 10^{-6} \text{ m}^2/\text{s}$$

For similarity,

Continued...

### PROBLEM 6.44 (Cont.)

$$\text{Re}_m = \text{Re}_s = 50.93 = \frac{V_m L_m}{\nu_m} = \frac{0.5 \text{ m/s} \times L_m}{163 \times 10^{-6} \text{ m}^2/\text{s}}$$

or  $L_m = 16.6 \times 10^{-3} \text{ m} = 16.6 \text{ mm}$

<

**COMMENTS:** (1) From Section 2.2.1, we know that the mean free path of air at room conditions is approximately 80 nm. Since  $L_s$  is three orders of magnitude greater than the mean free path, the air may be treated as a continuum. (2) Hydrogen can leak from enclosures easily. By keeping the wind tunnel pressure below atmospheric, we avoid possible leakage of flammable hydrogen into the lab. Also, if leaks occur, air must enter the wind tunnel. It is much easier to seal against air leaks than hydrogen leaks. (3)  $\text{Pr}_m = 0.707$  at 100 K also. However, the operation of the hydrogen wind tunnel at such a low temperature would be much more difficult than at 250 K.

### PROBLEM 6.45

**KNOWN:** Drag force and air flow conditions associated with a flat plate.

**FIND:** Rate of heat transfer from the plate.

**SCHEMATIC:**

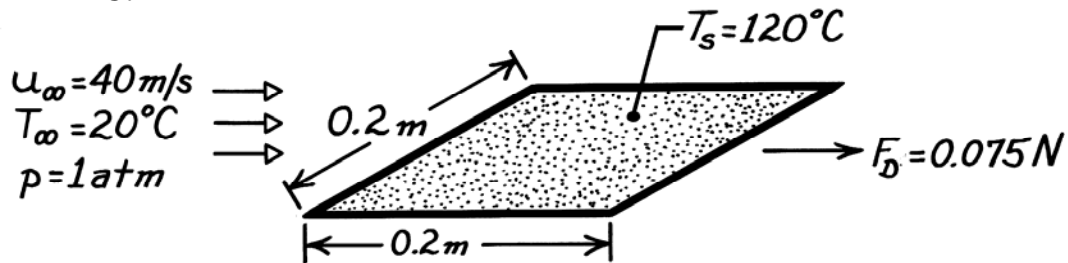

**ASSUMPTIONS:** (1) Chilton-Colburn analogy is applicable.

**PROPERTIES:** Table A-4, Air ( $70^\circ\text{C}$ , 1 atm):  $\rho = 1.018 \text{ kg/m}^3$ ,  $c_p = 1009 \text{ J/kg}\cdot\text{K}$ ,  $\text{Pr} = 0.70$ ,  $\nu = 20.22 \times 10^{-6} \text{ m}^2/\text{s}$ .

**ANALYSIS:** The rate of heat transfer from the plate is

$$q = 2\bar{h}(L^2) (T_s - T_\infty)$$

where  $\bar{h}$  may be obtained from the Chilton-Colburn analogy,

$$\begin{aligned} \frac{\bar{h}}{2} &= \frac{\bar{C}_f}{2} = \text{St} \text{Pr}^{2/3} = \frac{\bar{h}}{\rho u_\infty c_p} \text{Pr}^{2/3} \\ \frac{\bar{C}_f}{2} &= \frac{1}{2} \frac{\bar{\tau}_s}{\rho u_\infty^2 / 2} = \frac{1}{2} \frac{(0.075 \text{ N/2}) / (0.2 \text{ m})^2}{1.018 \text{ kg/m}^3 (40 \text{ m/s})^2 / 2} = 5.76 \times 10^{-4}. \end{aligned}$$

Hence,

$$\begin{aligned} \bar{h} &= \frac{\bar{C}_f}{2} \rho u_\infty c_p \text{Pr}^{-2/3} \\ \bar{h} &= 5.76 \times 10^{-4} (1.018 \text{ kg/m}^3) 40 \text{ m/s} (1009 \text{ J/kg}\cdot\text{K}) (0.70)^{-2/3} \\ \bar{h} &= 30 \text{ W/m}^2 \cdot \text{K}. \end{aligned}$$

The heat rate is

$$q = 2(30 \text{ W/m}^2 \cdot \text{K}) (0.2 \text{ m})^2 (120 - 20)^\circ\text{C}$$

$$q = 240 \text{ W}. \quad <$$

**COMMENTS:** Although the flow is laminar over the entire surface ( $\text{Re}_L = u_\infty L / \nu = 40 \text{ m/s} \times 0.2 \text{ m} / 20.22 \times 10^{-6} \text{ m}^2/\text{s} = 4.0 \times 10^5$ ), the pressure gradient is zero and the Chilton-Colburn analogy is applicable to *average*, as well as *local*, surface conditions. Note that the only contribution to the drag force is made by the surface shear stress.



### PROBLEM 6.46

**KNOWN:** Air flow conditions and drag force associated with a heater of prescribed surface temperature and area.

**FIND:** Required heater power.

**SCHEMATIC:**

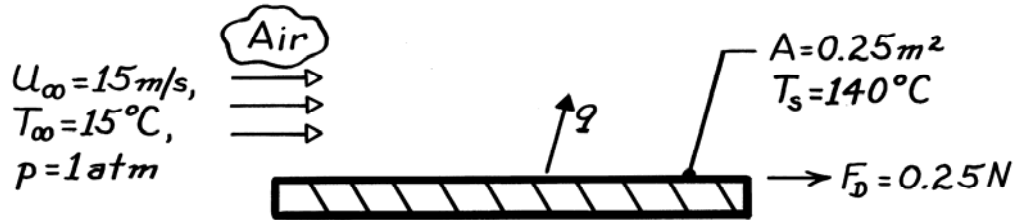

**ASSUMPTIONS:** (1) Steady-state conditions, (2) Reynolds analogy is applicable, (3) Bottom surface is adiabatic.

**PROPERTIES:** Table A-4, Air (\$T\_f = 350\text{K}\$, 1 atm): \$\rho = 0.995 \text{ kg/m}^3\$, \$c\_p = 1009 \text{ J/kg}\cdot\text{K}\$, \$\text{Pr} = 0.700\$.

**ANALYSIS:** The average shear stress and friction coefficient are

$$\bar{\tau}_s = \frac{F_D}{A} = \frac{0.25 \text{ N}}{0.25 \text{ m}^2} = 1 \text{ N/m}^2$$

$$\bar{C}_f = \frac{\bar{\tau}_s}{\rho u_\infty^2 / 2} = \frac{1 \text{ N/m}^2}{0.995 \text{ kg/m}^3 (15 \text{ m/s})^2 / 2} = 8.93 \times 10^{-3}$$

From the Reynolds analogy,

$$\bar{St} = \frac{\bar{h}}{\rho u_\infty c_p} = \frac{\bar{C}_f}{2} \text{Pr}^{-2/3}$$

Solving for \$\bar{h}\$ and substituting numerical values, find

$$\bar{h} = 0.995 \text{ kg/m}^3 (15 \text{ m/s}) 1009 \text{ J/kg}\cdot\text{K} \left( \frac{8.93 \times 10^{-3}}{2} \right) (0.7)^{-2/3}$$

$$\bar{h} = 85 \text{ W/m}^2 \cdot \text{K}$$

Hence, the heat rate is

$$q = \bar{h} A (T_s - T_\infty) = 85 \text{ W/m}^2 \cdot \text{K} \left( 0.25 \text{ m}^2 \right) (140 - 15)^\circ\text{C}$$

$$q = 2.66 \text{ kW}$$

<

**COMMENTS:** Due to bottom heat losses, which have been assumed negligible, the actual power requirement would exceed 2.66 kW.

### PROBLEM 6.47

**KNOWN:** Velocity of water flowing over a flat plate. Length and width of plate. Variation of local convection coefficient with  $x$  for  $T = 300$  K and  $T = 350$  K. Locations of turbulence transition.

**FIND:** Drag force for both water temperatures.

**SCHEMATIC:**

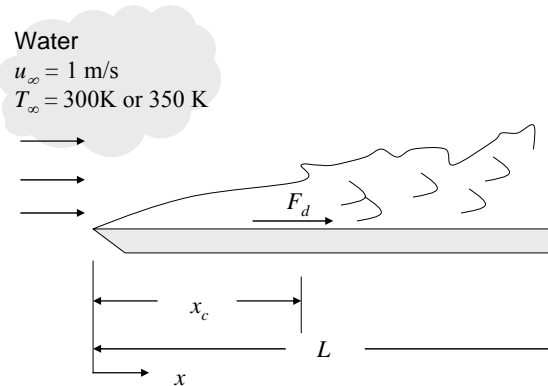

**ASSUMPTIONS:** (1) Steady-state conditions, (2) Transition occurs at a critical Reynolds number of  $5 \times 10^5$ , (3) Incompressible flow.

**PROPERTIES:** Table A.6, Water ( $T = 300$  K):  $\mu = 855 \times 10^{-6}$  N·s/m<sup>2</sup>,  $k = 0.613$  W/m·K. Water ( $T = 350$  K):  $\mu = 365 \times 10^{-6}$  N·s/m<sup>2</sup>,  $k = 0.668$  W/m·K.

**ANALYSIS:** According to the Reynolds analogy, Eq. 6.66

$$C_f \frac{Re_L}{2} = Nu$$

This relationship holds for the local values of  $C_f$  and  $Nu$ . The local shear stress can be expressed as

$$\tau_s = C_f \frac{\rho u_\infty^2}{2} = \frac{Nu}{Re_L} \rho u_\infty^2 = \frac{hx}{k} \frac{\rho u_\infty \nu}{L} = \frac{\mu u_\infty}{kL} hx = Bhx$$

where  $B = \mu u_\infty / kL$ . Therefore,  $\tau_{s,lam} = BC_{lam} x^{0.5}$  and  $\tau_{s,turb} = BC_{turb} x^{0.8}$ . Now the drag force can be found:

$$F_d = \int_0^L \tau_s dx \cdot W = \left[ \int_0^{x_c} BC_{lam} x^{0.5} dx + \int_{x_c}^L BC_{turb} x^{0.8} dx \right] W = BW \left[ C_{lam} \frac{x_c^{1.5}}{1.5} + C_{turb} \left( \frac{L^{1.8}}{1.8} - \frac{x_c^{1.8}}{1.8} \right) \right]$$

At  $T = 300$  K,

$$F_d = \frac{855 \times 10^{-6} \text{ N} \cdot \text{s} / \text{m}^2 \times 1 \text{ m} / \text{s}}{0.613 \text{ W} / \text{m} \cdot \text{K} \times 0.6 \text{ m}} \times 1 \text{ m} \\ \times \left[ 395 \text{ W} / \text{m}^{1.5} \cdot \text{K} \times \frac{(0.43 \text{ m})^{1.5}}{1.5} + 2330 \text{ W} / \text{m}^{1.8} \cdot \text{K} \left( \frac{(0.6 \text{ m})^{1.8}}{1.8} - \frac{(0.43 \text{ m})^{1.8}}{1.8} \right) \right]$$

$$F_d = 0.714 \text{ N}$$

<

Continued...

### PROBLEM 6.47 (Cont.)

Similarly, at  $T = 350$  K with  $C_{\text{lam}} = 477 \text{ W/m}^{1.5}\cdot\text{K}$ ,  $C_{\text{turb}} = 3600 \text{ W/m}^{1.8}\cdot\text{K}$  and  $x_c = 0.19$  m,

$$F_d = 0.659 \text{ N}$$

<

**COMMENTS:** (1) Even though transition to turbulence occurs earlier for the  $T = 350$  K case, the net effect of the much smaller viscosity is a reduction in the drag force. (2) It would be incorrect to apply Reynolds' analogy, Eq. 6.66, directly to the average values of  $C_f$  and  $Nu$  because of the presence of  $x$  in the definition of the Nusselt number. Applying Eq. 6.66 directly to the average values would result in the incorrect values  $F_d = 1.36$  and  $1.22$  N for the 300 K and 350 K cases, respectively.

### PROBLEM 6.48

**KNOWN:** Heat transfer correlation associated with parallel flow over a rough flat plate. Velocity and temperature of air flow over the plate.

**FIND:** Surface shear stress 1 m from the leading edge.

**SCHEMATIC:**

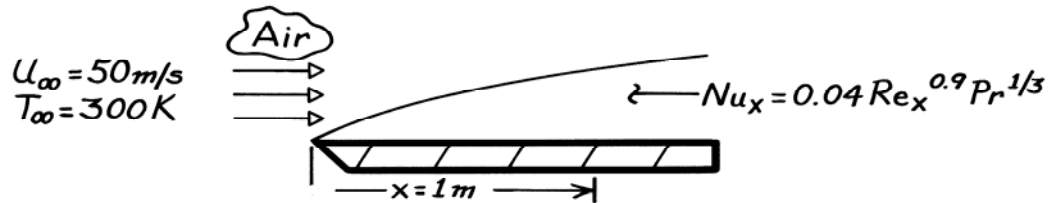

**ASSUMPTIONS:** (1) Modified Reynolds analogy is applicable, (2) Constant properties.

**PROPERTIES:** Table A-4, Air (300K, 1atm):  $\nu = 15.89 \times 10^{-6} \text{ m}^2/\text{s}$ ,  $\text{Pr} = 0.71$ ,  $\rho = 1.16 \text{ kg/m}^3$ .

**ANALYSIS:** Applying the Chilton-Colburn analogy

$$\frac{C_f}{2} = \text{St}_x \text{Pr}^{2/3} = \frac{\text{Nu}_x}{\text{Re}_x \text{Pr}} \text{Pr}^{2/3} = \frac{0.04 \text{Re}_x^{0.9} \text{Pr}^{1/3}}{\text{Re}_x \text{Pr}} \text{Pr}^{2/3}$$

$$\frac{C_f}{2} = 0.04 \text{Re}_x^{-0.1}$$

where

$$\text{Re}_x = \frac{u_\infty x}{\nu} = \frac{50 \text{ m/s} \times 1 \text{ m}}{15.89 \times 10^{-6} \text{ m}^2/\text{s}} = 3.15 \times 10^6.$$

Hence, the friction coefficient is

$$C_f = 0.08 \left( 3.15 \times 10^6 \right)^{-0.1} = 0.0179 = \tau_s / \left( \rho u_\infty^2 / 2 \right)$$

and the surface shear stress is

$$\tau_s = C_f \left( \rho u_\infty^2 / 2 \right) = 0.0179 \times 1.16 \text{ kg/m}^3 (50 \text{ m/s})^2 / 2$$

$$\tau_s = 25.96 \text{ kg/m} \cdot \text{s}^2 = 25.96 \text{ N/m}^2.$$

**COMMENTS:** Note that turbulent flow will exist at the designated location.

### PROBLEM 6.49

**KNOWN:** Dimensions and temperature of a thin, rough plate. Velocity of air flow parallel to plate (at an angle of 45° to a side). Heat transfer rate from plate to air.

**FIND:** Drag force on plate.

**SCHEMATIC:**

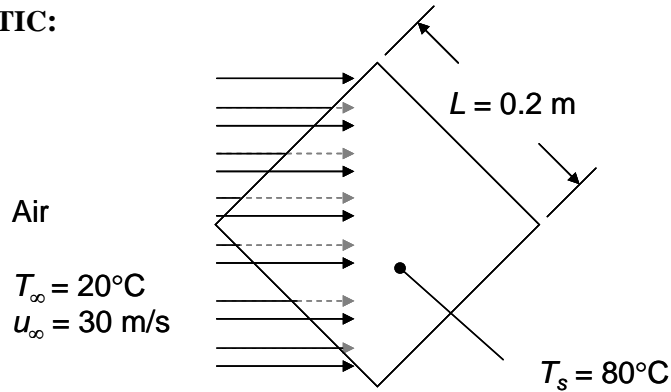

**ASSUMPTIONS:** (1) The modified Reynolds analogy holds, (2) Constant properties.

**PROPERTIES:** Table A-4, Air (50°C = 323 K):  $c_p = 1008 \text{ J/kg}\cdot\text{K}$ ,  $Pr = 0.704$ .

**ANALYSIS:** The modified Reynolds analogy, Equation 6.70, combined with the definition of the Stanton number, Equation 6.67, yields

$$C_f/2 = (Nu/Re)Pr^{-1/3} \quad (1)$$

The drag force is related to the friction coefficient according to

$$F_D = \tau_s A_s = C_f \cdot \rho u_\infty^2 A_s / 2 \quad (2)$$

Combining Equations (1) and (2)

$$F_D = \frac{Nu}{Re} Pr^{-1/3} \rho u_\infty^2 A_s$$

Substituting the definitions of Nu and Re, we find

$$F_D = \frac{h L_c}{k} \frac{v}{u_\infty L_c} Pr^{-1/3} \rho u_\infty^2 A_s = \frac{h}{c_p} \frac{v}{\alpha} Pr^{-1/3} u_\infty A_s = \frac{h}{c_p} Pr^{2/3} u_\infty A_s$$

Where  $L_c$  is a characteristic length used to define Nu and Re. With  $h A_s = q / \Delta T$  we have

$$F_D = \frac{q u_\infty Pr^{2/3}}{c_p \Delta T} = \frac{2000 \text{ W} \times 30 \text{ m/s} \times (0.704)^{2/3}}{1008 \text{ J/kg}\cdot\text{K} \times 60 \text{ K}} = 0.785 \text{ N} \quad \leftarrow$$

**COMMENTS:** (1) Heat transfer or friction coefficient correlations for this simple configuration apparently do not exist. (2) Experiments to measure the drag force would be relatively simple to implement and measured drag forces could be used to determine the heat transfer coefficients using the Reynolds analogy. (3) The solution demonstrates advantages associated with working the problem symbolically and only introducing numbers at the end. First, the length scale in Nu and Re did not have to be defined because it cancelled out. Second, the properties  $k$ ,  $v$ , and  $\rho$  also cancelled out.

## PROBLEM 6.50

**KNOWN:** Nominal operating conditions of aircraft and characteristic length and average friction coefficient of wing.

**FIND:** Average heat flux needed to maintain prescribed surface temperature of wing.

**SCHEMATIC:**

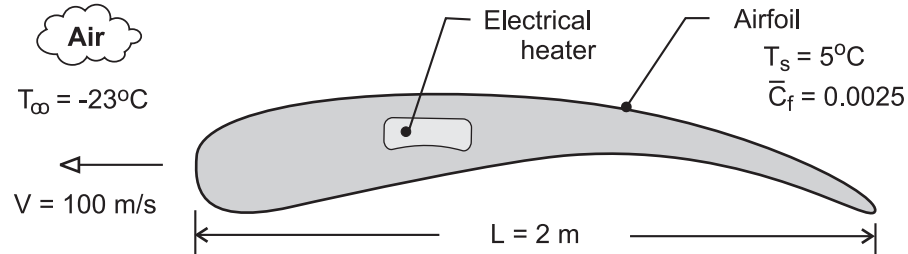

**ASSUMPTIONS:** (1) Applicability of modified Reynolds analogy, (2) Constant properties.

**PROPERTIES:** Prescribed, Air:  $\nu = 16.3 \times 10^{-6}\text{ m}^2/\text{s}$ ,  $k = 0.022\text{ W/m}\cdot\text{K}$ ,  $\text{Pr} = 0.72$ .

**ANALYSIS:** The average heat flux that must be maintained over the surface of the air foil is  $\bar{q}'' = \bar{h}(T_s - T_\infty)$ , where the average convection coefficient may be obtained from the modified Reynolds analogy.

$$\frac{\bar{C}_f}{2} = \text{St Pr}^{2/3} = \frac{\bar{\text{Nu}}_L}{\text{Re}_L \text{Pr}} \text{Pr}^{2/3} = \frac{\bar{\text{Nu}}_L}{\text{Re}_L \text{Pr}^{1/3}}$$

Hence, with  $\text{Re}_L = VL/\nu = 100\text{ m/s}(2\text{ m})/16.3 \times 10^{-6}\text{ m}^2/\text{s} = 1.23 \times 10^7$ ,

$$\bar{\text{Nu}}_L = \frac{0.0025}{2} (1.23 \times 10^7) (0.72)^{1/3} = 13,780$$

$$\bar{h} = \frac{k}{L} \bar{\text{Nu}}_L = \frac{0.022\text{ W/m}\cdot\text{K}}{2\text{ m}} (13,780) = 152\text{ W/m}^2\cdot\text{K}$$

$$\bar{q}'' = 152\text{ W/m}^2\cdot\text{K} [5 - (-23)]^\circ\text{C} = 4260\text{ W/m}^2$$

<

**COMMENTS:** If the flow is turbulent over the entire airfoil, the modified Reynolds analogy provides a good measure of the relationship between surface friction and heat transfer. The relation becomes more approximate with increasing laminar boundary layer development on the surface and increasing values of the magnitude of the pressure gradient.

## PROBLEM 6.51

**KNOWN:** Average frictional shear stress of  $\bar{\tau}_s = 0.0625 \text{ N/m}^2$  on upper surface of circuit board with densely packed integrated circuits (ICs)

**FIND:** Allowable power dissipation from the upper surface of the board if the average surface temperature of the ICs must not exceed a rise of  $25^\circ\text{C}$  above ambient air temperature.

**SCHEMATIC:**

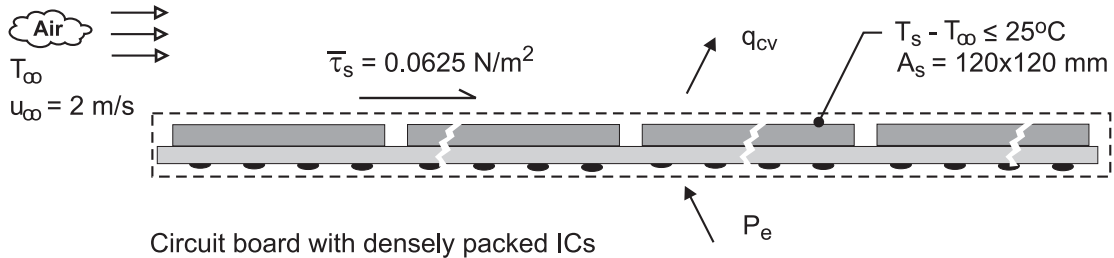

**ASSUMPTIONS:** (1) Steady-state conditions, (2) The modified Reynolds analogy is applicable, (3) Negligible heat transfer from bottom side of the circuit board, and (4) Thermophysical properties required for the analysis evaluated at  $300 \text{ K}$ ,

**PROPERTIES:** Table A-4, Air ( $T_f = 300 \text{ K}$ ,  $1 \text{ atm}$ ):  $\rho = 1.161 \text{ kg/m}^3$ ,  $c_p = 1007 \text{ J/kg}\cdot\text{K}$ ,  $\text{Pr} = 0.707$ .

**ANALYSIS:** The power dissipation from the circuit board can be calculated from the convection rate equation assuming an excess temperature  $(T_s - T_\infty) = 25^\circ\text{C}$ .

$$q = \bar{h} A_s (T_s - T_\infty) \quad (1)$$

The average convection coefficient can be estimated from the Reynolds analogy and the measured average frictional shear stress  $\bar{\tau}_s$ .

$$\frac{\bar{C}_f}{2} = \bar{\text{St}} \text{Pr}^{2/3} \quad \bar{C}_f = \frac{\bar{\tau}_s}{\rho V^2 / 2} \quad \bar{\text{St}} = \frac{\bar{h}}{\rho V c_p} \quad (2,3,4)$$

With  $V = u_\infty$  and substituting numerical values, find  $\bar{h}$ .

$$\frac{\bar{\tau}_s}{\rho V^2} = \frac{\bar{h}}{\rho V c_p} \text{Pr}^{2/3}$$

$$\bar{h} = \frac{\bar{\tau}_s c_p}{V} \text{Pr}^{-2/3}$$

$$\bar{h} = \frac{0.0625 \text{ N/m}^2 \times 1007 \text{ J/kg}\cdot\text{K}}{2 \text{ m/s}} (0.707)^{-2/3} = 39.7 \text{ W/m}^2 \cdot \text{K}$$

Substituting this result into Eq. (1), the allowable power dissipation is

$$q = 39.7 \text{ W/m}^2 \cdot \text{K} \times (0.120 \times 0.120) \text{ m}^2 \times 25 \text{ K} = 14.3 \text{ W} \quad <$$

**COMMENTS:** For this analysis using the modified or Chilton-Colburn analogy, we found  $C_f = 0.0269$  and  $\text{St} = 0.0170$ . Using the Reynolds analogy, the results are slightly different with

$\bar{h} = 31.5 \text{ W/m}^2 \cdot \text{K}$  and  $q = 11.3 \text{ W}$ .

## PROBLEM 6.52

**KNOWN:** Evaporation rate of water from a lake.

**FIND:** The convection mass transfer coefficient,  $\bar{h}_m$ .

**SCHEMATIC:**

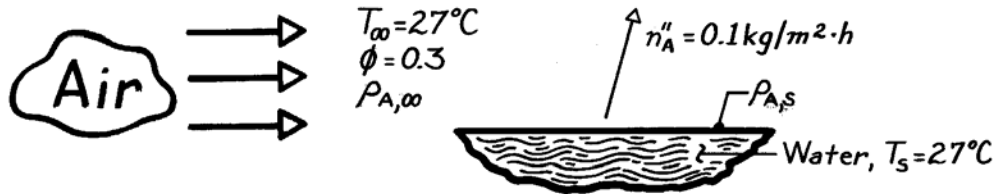

**ASSUMPTIONS:** (1) Equilibrium at water vapor-liquid surface, (2) Isothermal conditions, (3) Perfect gas behavior of water vapor, (4) Air at standard atmospheric pressure.

**PROPERTIES:** Table A-6, Saturated water vapor (300K):  $p_{A,\text{sat}} = 0.03531 \text{ bar}$ ,  $\rho_{A,\text{sat}} = 1/v_g = 0.02556 \text{ kg/m}^3$ .

**ANALYSIS:** The convection mass transfer (evaporation) rate equation can be written in the form

$$\bar{h}_m = \frac{n_A''}{(\rho_{A,s} - \rho_{A,\infty})}$$

where

$$\rho_{A,s} = \rho_{A,\text{sat}}$$

the saturation density at the temperature of the water and

$$\rho_{A,\infty} = \phi \rho_{A,\text{sat}}$$

which follows from the definition of the relative humidity,  $\phi = p_A/p_{A,\text{sat}}$  and perfect gas behavior. Hence,

$$\bar{h}_m = \frac{n_A''}{\rho_{A,\text{sat}}(1-\phi)}$$

and substituting numerical values, find

$$\bar{h}_m = \frac{0.1 \text{ kg/m}^2 \cdot \text{h} \times 1/3600 \text{ s/h}}{0.02556 \text{ kg/m}^3 (1-0.3)} = 1.55 \times 10^{-3} \text{ m/s.} \quad <$$

**COMMENTS:** (1) From knowledge of  $p_{A,\text{sat}}$ , the perfect gas law could be used to obtain the saturation density.

$$\rho_{A,\text{sat}} = \frac{p_{A,\text{sat}} \mathcal{M}_A}{\mathcal{R}T} = \frac{0.03531 \text{ bar} \times 18 \text{ kg/kmol}}{8.314 \times 10^{-2} \text{ m}^3 \cdot \text{bar/kmol} \cdot \text{K} (300\text{K})} = 0.02548 \text{ kg/m}^3.$$

This value is within 0.3% of that obtained from Table A-6.

(2) Note that psychrometric charts could also be used to obtain  $\rho_{A,\text{sat}}$  and  $\rho_{A,\infty}$ .



### PROBLEM 6.53

**KNOWN:** Evaporation rate from pan of water of prescribed diameter. Water temperature. Air temperature and relative humidity.

**FIND:** (a) Convection mass transfer coefficient, (b) Evaporation rate for increased relative humidity, (c) Evaporation rate for increased temperature.

**SCHEMATIC:**

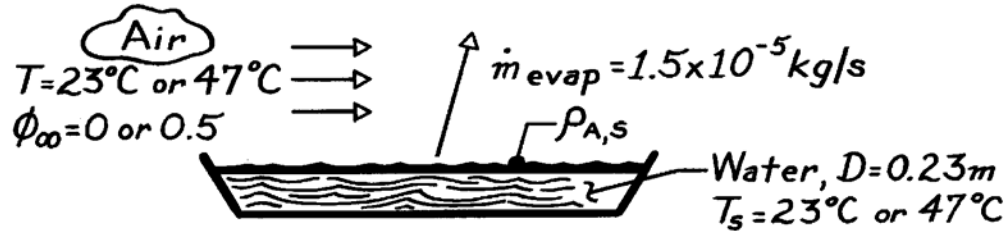

**ASSUMPTIONS:** (1) Water vapor is saturated at liquid interface and may be approximated as a perfect gas.

**PROPERTIES:** Table A-6, Saturated water vapor ( $T_s = 296\text{K}$ ):  $\rho_{A,\text{sat}} = v_g^{-1} = (49.4 \text{ m}^3/\text{kg})^{-1} = 0.0202 \text{ kg/m}^3$ ; ( $T_s = 320 \text{ K}$ ):  $\rho_{A,\text{sat}} = v_g^{-1} = (13.98 \text{ m}^3/\text{kg})^{-1} = 0.0715 \text{ kg/m}^3$ .

**ANALYSIS:** (a) Since evaporation is a convection mass transfer process, the rate equation has the form  $\dot{m}_{\text{evap}} = \bar{h}_m A (\rho_{A,s} - \rho_{A,\infty})$  and the mass transfer coefficient is

$$\bar{h}_m = \frac{\dot{m}_{\text{evap}}}{(\pi D^2/4)(\rho_{A,s} - \rho_{A,\infty})} = \frac{1.5 \times 10^{-5} \text{ kg/s}}{(\pi/4)(0.23 \text{ m})^2 0.0202 \text{ kg/m}^3} = 0.0179 \text{ m/s} <$$

with  $T_s = T_\infty = 23^\circ\text{C}$  and  $\phi_\infty = 0$ .

(b) If the relative humidity of the ambient air is increased to 50%, the ratio of the evaporation rates is

$$\frac{\dot{m}_{\text{evap}}(\phi_\infty = 0.5)}{\dot{m}_{\text{evap}}(\phi_\infty = 0)} = \frac{\bar{h}_m A [\rho_{A,s}(T_s) - \phi_\infty \rho_{A,s}(T_\infty)]}{\bar{h}_m A \rho_{A,s}(T_s)} = 1 - \phi_\infty \frac{\rho_{A,s}(T_\infty)}{\rho_{A,s}(T_s)}.$$

$$\text{Hence, } \dot{m}_{\text{evap}}(\phi_\infty = 0.5) = 1.5 \times 10^{-5} \text{ kg/s} \left[ 1 - 0.5 \frac{0.0202 \text{ kg/m}^3}{0.0202 \text{ kg/m}^3} \right] = 0.75 \times 10^{-5} \text{ kg/s}.$$

(c) If the temperature of the ambient air is increased from  $23^\circ\text{C}$  to  $47^\circ\text{C}$ , with  $\phi_\infty = 0$  for both cases, the ratio of the evaporation rates is

$$\frac{\dot{m}_{\text{evap}}(T_s = T_\infty = 47^\circ\text{C})}{\dot{m}_{\text{evap}}(T_s = T_\infty = 23^\circ\text{C})} = \frac{\bar{h}_m A \rho_{A,s}(47^\circ\text{C})}{\bar{h}_m A \rho_{A,s}(23^\circ\text{C})} = \frac{\rho_{A,s}(47^\circ\text{C})}{\rho_{A,s}(23^\circ\text{C})}.$$

$$\text{Hence, } \dot{m}_{\text{evap}}(T_s = T_\infty = 47^\circ\text{C}) = 1.5 \times 10^{-5} \text{ kg/s} \frac{0.0715 \text{ kg/m}^3}{0.0202 \text{ kg/m}^3} = 5.31 \times 10^{-5} \text{ kg/s} <$$

**COMMENTS:** Note the highly nonlinear dependence of the evaporation rate on the water temperature. For a  $24^\circ\text{C}$  rise in  $T_s$ ,  $\dot{m}_{\text{evap}}$  increases by 350%.

### PROBLEM 6.54

**KNOWN:** Water temperature and air temperature and relative humidity. Surface recession rate.

**FIND:** Mass evaporation rate per unit area. Convection mass transfer coefficient.

**SCHEMATIC:**

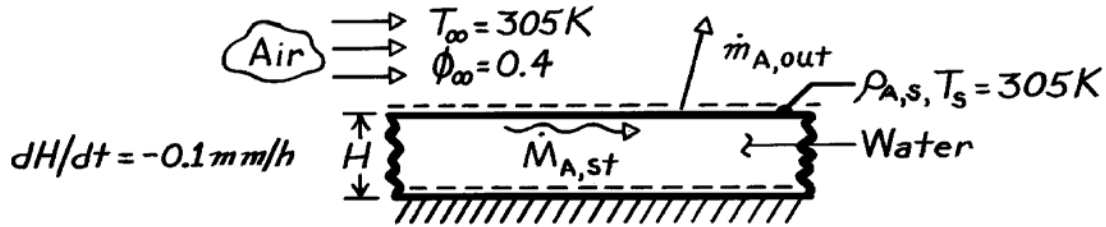

**ASSUMPTIONS:** (1) Water vapor may be approximated as a perfect gas, (2) No water inflow; outflow is only due to evaporation.

**PROPERTIES:** Table A-6, Saturated water: Vapor (305K),  $\rho_g = v_g^{-1} = 0.0336\text{ kg/m}^3$ ; Liquid (305K),  $\rho_f = v_f^{-1} = 995\text{ kg/m}^3$ .

**ANALYSIS:** Applying conservation of species to a control volume about the water,

$$-\dot{M}_{A,out} = \dot{M}_{A,st}$$

$$-\dot{m}''_{\text{evap}} A = \frac{d}{dt}(\rho_f V) = \frac{d}{dt}(\rho_f AH) = \rho_f A \frac{dH}{dt}.$$

Substituting numerical values, find

$$\dot{m}''_{\text{evap}} = -\rho_f \frac{dH}{dt} = -995\text{ kg/m}^3 (-10^{-4}\text{ m/h}) (1/3600\text{ s/h})$$

$$\dot{m}''_{\text{evap}} = 2.76 \times 10^{-5}\text{ kg/s} \cdot \text{m}^2. \quad <$$

Because evaporation is a convection mass transfer process, it also follows that

$$\dot{m}''_{\text{evap}} = n''_A$$

or in terms of the rate equation,

$$\dot{m}''_{\text{evap}} = h_m (\rho_{A,s} - \rho_{A,\infty}) = h_m [\rho_{A,\text{sat}}(T_s) - \phi_\infty \rho_{A,\text{sat}}(T_\infty)]$$

$$\dot{m}''_{\text{evap}} = h_m \rho_{A,\text{sat}}(305\text{ K}) (1 - \phi_\infty),$$

and solving for the convection mass transfer coefficient,

$$h_m = \frac{\dot{m}''_{\text{evap}}}{\rho_{A,\text{sat}}(305\text{ K}) (1 - \phi_\infty)} = \frac{2.76 \times 10^{-5}\text{ kg/s} \cdot \text{m}^2}{0.0336\text{ kg/m}^3 (1 - 0.4)}$$

$$h_m = 1.37 \times 10^{-3}\text{ m/s}. \quad <$$

**COMMENTS:** Conservation of species has been applied in exactly the same way as a conservation of energy. Note the sign convention.

### PROBLEM 6.55

**KNOWN:** CO<sub>2</sub> concentration in air and at the surface of a green leaf. Convection mass transfer coefficient.

**FIND:** Rate of photosynthesis per unit area of leaf.

**SCHEMATIC:**

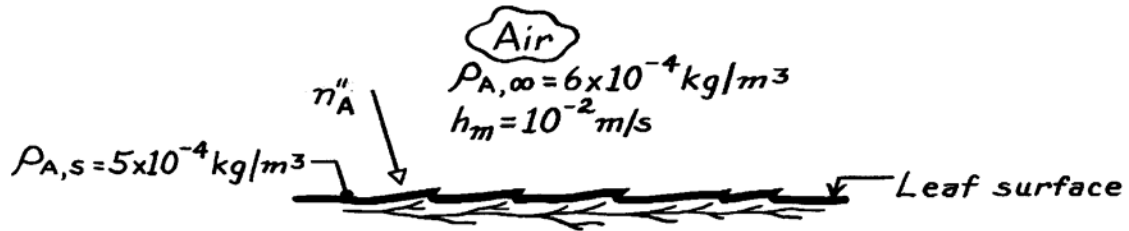

**ANALYSIS:** Assuming that the CO<sub>2</sub> (species A) is consumed as a reactant in photosynthesis at the same rate that it is transferred across the atmospheric boundary layer, the rate of photosynthesis per unit leaf surface area is given by the rate equation,

$$n''_A = h_m (\rho_{A,\infty} - \rho_{A,s}).$$

Substituting numerical values, find

$$n''_A = 10^{-2} \text{ m/s} (6 \times 10^{-4} - 5 \times 10^{-4}) \text{ kg/m}^3$$

$$n''_A = 10^{-6} \text{ kg/s} \cdot \text{m}^2. \quad <$$

**COMMENTS:** (1) It is recognized that CO<sub>2</sub> transport is from the air to the leaf, and  $(\rho_{A,s} - \rho_{A,\infty})$  in the rate equation has been replaced by  $(\rho_{A,\infty} - \rho_{A,s})$ .

(2) The atmospheric concentration of CO<sub>2</sub> is known to be increasing by approximately 0.3% per year. This increase in  $\rho_{A,\infty}$  will have the effect of increasing the photosynthesis rate and hence plant biomass production.

### PROBLEM 6.56

**KNOWN:** Species concentration profile,  $C_A(y)$ , in a boundary layer at a particular location for flow over a surface.

**FIND:** Expression for the mass transfer coefficient,  $h_m$ , in terms of the profile constants,  $C_{A,\infty}$  and  $D_{AB}$ . Expression for the molar convection flux,  $N_A''$ .

**SCHEMATIC:**

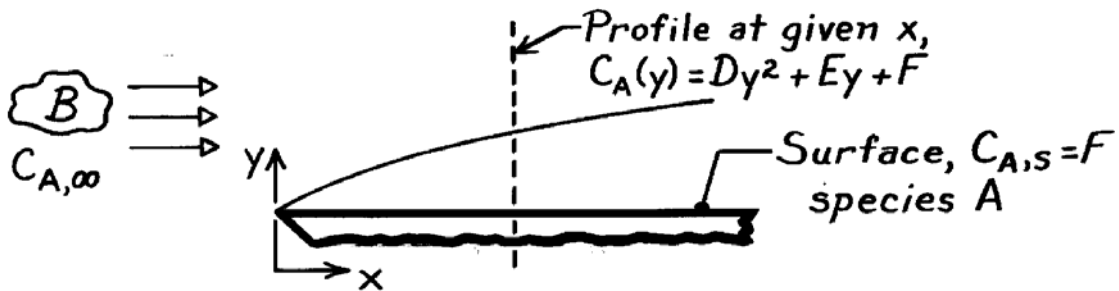

**ASSUMPTIONS:** (1) Parameters  $D$ ,  $E$ , and  $F$  are constants at any location  $x$ , (2)  $D_{AB}$ , the mass diffusion coefficient of  $A$  through  $B$ , is known.

**ANALYSIS:** The convection mass transfer coefficient is defined in terms of the concentration gradient at the wall,

$$h_m(x) = -D_{AB} \left. \frac{\partial C_A / \partial y}{(C_{A,s} - C_{A,\infty})} \right|_{y=0}$$

The gradient at the surface follows from the profile,  $C_A(y)$ ,

$$\left. \frac{\partial C_A}{\partial y} \right|_{y=0} = \left. \frac{\partial}{\partial y} (Dy^2 + Ey + F) \right|_{y=0} = +E$$

Hence,

$$h_m(x) = -\frac{D_{AB}E}{(C_{A,s} - C_{A,\infty})} = \frac{-D_{AB}E}{(F - C_{A,\infty})} \quad <$$

The molar flux follows from the rate equation,

$$N_A'' = h_m (C_{A,s} - C_{A,\infty}) = \frac{-D_{AB}E}{(C_{A,s} - C_{A,\infty})} \cdot (C_{A,s} - C_{A,\infty})$$

$$N_A'' = -D_{AB}E \quad <$$

**COMMENTS:** It is important to recognize that the influence of species  $B$  is present in the property  $D_{AB}$ . Otherwise, all the parameters relate to species  $A$ .

### PROBLEM 6.57

**KNOWN:** Cross flow of gas X over object with prescribed characteristic length L, Reynolds number, and average heat transfer coefficient. Thermophysical properties of gas X, liquid Y, and vapor Y.

**FIND:** Average mass transfer coefficient for same object when impregnated with liquid Y and subjected to same flow conditions.

**SCHEMATIC:**

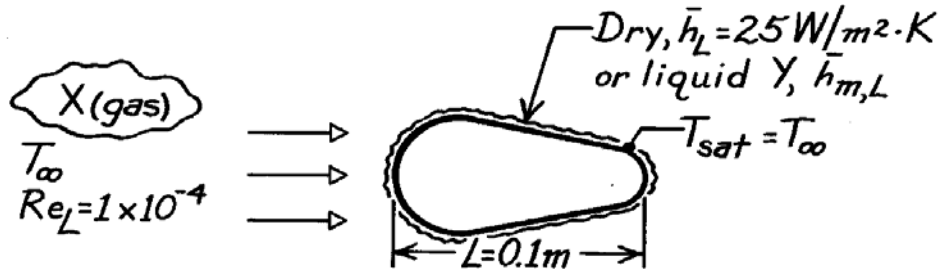

**ASSUMPTIONS:** (1) Heat and mass transfer analogy is applicable, (2) Vapor Y behaves as perfect gas

<b>PROPERTIES:</b>	(Given)	$\nu$ (m <sup>2</sup> /s)	$k$ (W/m·K)	$\alpha$ (m <sup>2</sup> /s)
Gas X		$21 \times 10^{-6}$	0.030	$29 \times 10^{-6}$
Liquid Y		$3.75 \times 10^{-7}$	0.665	$1.65 \times 10^{-7}$
Vapor Y		$4.25 \times 10^{-5}$	0.023	$4.55 \times 10^{-5}$
Mixture of gas X - vapor Y:			$Sc = 0.72$	

**ANALYSIS:** The heat-mass transfer analogy may be written as

$$\overline{Nu}_L = \frac{\bar{h}_L L}{k} = f(Re_L, Pr) \quad \overline{Sh}_L = \frac{\bar{h}_{m,L} L}{D_{AB}} = f(Re_L, Sc)$$

The flow conditions are the same for both situations. Check values of Pr and Sc. For Pr, the properties are those for gas X (B).

$$Pr = \frac{\nu_B}{\alpha_B} = \frac{21 \times 10^{-6} \text{ m}^2/\text{s}}{29 \times 10^{-6} \text{ m}^2/\text{s}} = 0.72$$

while  $Sc = 0.72$  for the gas X (B) - vapor Y (A) mixture. It follows for this situation

$$\overline{Nu}_L = \frac{\bar{h}_L L}{k} = \overline{Sh}_L = \frac{\bar{h}_{m,L} L}{D_{AB}} \quad \text{or} \quad \bar{h}_{m,L} = \bar{h}_L \frac{D_{AB}}{k}$$

Recognizing that

$$D_{AB} = \nu_B / Sc = 21.6 \times 10^{-6} \text{ m}^2/\text{s} / (0.72) = 30.0 \times 10^{-6} \text{ m}^2/\text{s}$$

and substituting numerical values, find

$$\bar{h}_{m,L} = 25 \text{ W/m}^2 \cdot \text{K} \times \frac{30.0 \times 10^{-6} \text{ m}^2/\text{s}}{0.030 \text{ W/m} \cdot \text{K}} = 0.0250 \text{ m/s.} \quad <$$

**COMMENTS:** Note that none of the thermophysical properties of liquid or vapor Y are required for the solution. Only the gas X properties and the Schmidt number (gas X - vapor Y) are required.

### PROBLEM 6.58

**KNOWN:** Free stream velocity and average convection mass transfer coefficient for fluid flow over a surface of prescribed characteristic length.

**FIND:** Values of  $\overline{Sh}_L$ ,  $Re_L$ ,  $Sc$  and  $\overline{j}_m$  for (a) air flow over water, (b) air flow over naphthalene, and (c) warm glycerol over ice.

**SCHEMATIC:**

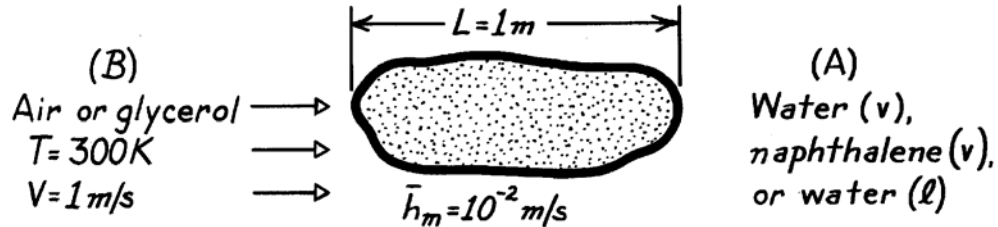

**PROPERTIES:** For the fluids at 300K:

Table	Fluid(s)	$\nu(m^2/s) \times 10^{-6}$	$D_{AB}(m^2/s)$
A-4	Air	15.89	-
A-5	Glycerin	634	-
A-8	Water vapor - Air	-	$0.26 \times 10^{-4}$
A-8	Naphthalene - Air	-	$0.62 \times 10^{-5}$
A-8	Water - Glycerol	-	$0.94 \times 10^{-9}$

**ANALYSIS:** (a) *Water (vapor) - Air:*

$$\overline{Sh}_L = \frac{\overline{h}_m L}{D_{AB}} = \frac{(0.01 \text{ m/s}) 1 \text{ m}}{0.26 \times 10^{-4} \text{ m}^2/\text{s}} = 385$$

$$Re_L = \frac{VL}{\nu} = \frac{(1 \text{ m/s}) 1 \text{ m}}{15.89 \times 10^{-6} \text{ m}^2/\text{s}} = 6.29 \times 10^4$$

$$Sc = \frac{\nu}{D_{AB}} = \frac{0.16 \times 10^{-6} \text{ m}^2/\text{s}}{0.26 \times 10^{-6} \text{ m}^2/\text{s}} = 0.62$$

$$\overline{j}_m = St_m Sc^{2/3} = \frac{\overline{h}_m}{V} Sc^{2/3} = \frac{0.01 \text{ m/s}}{1 \text{ m/s}} (0.62)^{2/3} = 0.0073. \quad <$$

(b) *Naphthalene (vapor) - Air:*

$$\overline{Sh}_L = 1613 \quad Re_L = 6.29 \times 10^4 \quad Sc = 2.56 \quad \overline{j}_m = 0.0187. \quad <$$

(c) *Water (liquid) - Glycerol:*

$$\overline{Sh}_L = 1.06 \times 10^7 \quad Re_L = 1577 \quad Sc = 6.74 \times 10^5 \quad \overline{j}_m = 76.9. \quad <$$

**COMMENTS:** Note the association of  $\nu$  with the freestream fluid B.

### PROBLEM 6.59

**KNOWN:** Characteristic length, surface temperature, average heat flux and airstream conditions associated with an object of irregular shape.

**FIND:** Whether similar behavior exists for alternative conditions, and average convection coefficient for similar cases.

#### SCHEMATIC:

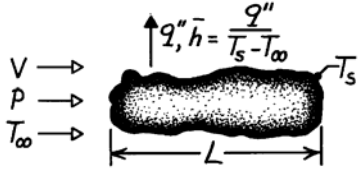

	Case: 1	2	3	4	5
L, m	1	2	2	2	2
V, m/s	100	50	50	50	250
p, atm	1	1	0.2	1	0.2
T <sub>∞</sub> , K	275	275	275	300	300
T <sub>s</sub> , K	325	325	325	300	300

$q''$ , W/m <sup>2</sup>	12,000	-	-	-	-
$\bar{h}$ , W/m <sup>2</sup> · K	240	-	-	-	-
$D_{AB} \times 10^{+4}$ , m <sup>2</sup> /s	-	-	-	1.12	1.12

**ASSUMPTIONS:** (1) Heat and mass transfer analogy is applicable; that is,  $f(Re_L, Pr) = f(Re_L, Sc)$ , see Eqs. 6.50 and 6.54.

**PROPERTIES:** Table A-4, Air (300K, 1 atm):  $\nu_1 = 15.89 \times 10^{-6} \text{ m}^2/\text{s}$ ,  $Pr_1 = 0.71$ ,  $k_1 = 0.0263 \text{ W/m} \cdot \text{K}$ .

**ANALYSIS:** For Case 1,  $h = q''/(T_s - T_\infty) = 12,000 \text{ W/m}^2/50 \text{ K} = 240 \text{ W/m}^2 \cdot \text{K}$ .

$Re_{L,1} = V_1 L_1 / \nu_1 = (100 \text{ m/s} \times 1\text{m}) / 15.89 \times 10^{-6} \text{ m}^2/\text{s} = 6.29 \times 10^6$  and  $Pr_1 = 0.71$ .

Case 2:  $Re_{L,2} = \frac{V_2 L_2}{\nu_2} = \frac{50 \text{ m/s} \times 2\text{m}}{15.89 \times 10^{-6} \text{ m}^2/\text{s}} = 6.29 \times 10^6$ ,  $Pr_2 = 0.71$ .

From Eq. 6.50 it follows that Case 2 is analogous to Case 1. Hence  $\overline{Nu}_2 = \overline{Nu}_1$  and

$$\bar{h}_2 = \frac{\bar{h}_1 L_1}{k_1} \frac{k_2}{L_2} = \bar{h}_1 \frac{L_1}{L_2} = 240 \frac{\text{W}}{\text{m}^2 \cdot \text{K}} \frac{1\text{m}}{2\text{m}} = 120 \text{ W/m}^2 \cdot \text{K}. \quad <$$

Case 3: With  $p = 0.2 \text{ atm}$ ,  $\nu_3 = 79.45 \times 10^{-6} \text{ m}^2/\text{s}$  and  $Re_{L,3} = \frac{V_3 L_3}{\nu_3} = \frac{50 \text{ m/s} \times 2\text{m}}{79.45 \times 10^{-6} \text{ m}^2/\text{s}} = 1.26 \times 10^6$ ,  $Pr_3 = 0.71$ .

Since  $Re_{L,3} \neq Re_{L,1}$ , Case 3 is not analogous to Case 1. <

Case 4:  $Re_{L,4} = Re_{L,1}$ ,  $Sc_4 = \frac{\nu_4}{D_{AB,4}} = \frac{15.89 \times 10^{-6} \text{ m}^2/\text{s}}{1.12 \times 10^{-4} \text{ m}^2/\text{s}} = 0.142 \neq Pr_1$ .

Hence, Case 4 is not analogous to Case 1. <

Case 5:  $Re_{L,5} = \frac{V_5 L_5}{\nu_5} = \frac{250 \text{ m/s} \times 2\text{m}}{79.45 \times 10^{-6} \text{ m}^2/\text{s}} = 6.29 \times 10^6 = Re_{L,1}$

$$Sc_5 = \frac{\nu_5}{D_{AB,5}} = \frac{79.45 \times 10^{-6} \text{ m}^2/\text{s}}{1.12 \times 10^{-4} \text{ m}^2/\text{s}} = 0.71 = Pr_1.$$

Hence, conditions are analogous to Case 1, and with  $\overline{Sh}_5 = \overline{Nu}_1$ ,

$$h_{m,5} = h_1 \frac{L_1}{L_5} \frac{D_{AB,5}}{k_1} = 240 \frac{\text{W}}{\text{m}^2 \cdot \text{K}} \times \frac{1\text{m}}{2\text{m}} \times \frac{1.12 \times 10^{-4} \text{ m}^2/\text{s}}{0.0263 \text{ W/m} \cdot \text{K}} = 0.51 \text{ m/s}. \quad <$$

**COMMENTS:** Note that  $Pr$ ,  $k$  and  $Sc$  are independent of pressure, while  $\nu$  and  $D_{AB}$  vary inversely with pressure.

### PROBLEM 6.60

**KNOWN:** Surface temperature and heat loss from a runner's body on a cool, spring day. Surface temperature and ambient air-conditions for a warm summer day.

**FIND:** (a) Water loss on summer day, (b) Total heat loss on summer day.

**SCHEMATIC:**

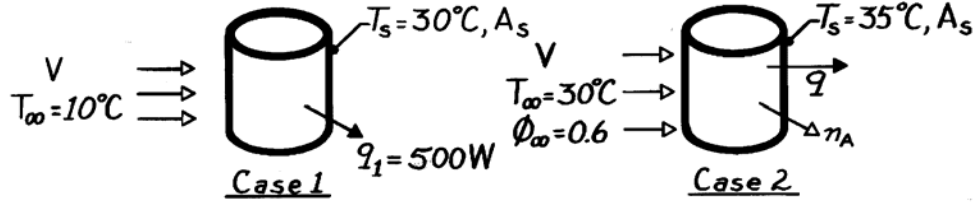

**ASSUMPTIONS:** (1) Heat and mass transfer analogy is applicable. Hence, from Eqs. 6.50 and 6.54,  $f(Re_L, Pr)$  is of same form as  $f(Re_L, Sc)$ , (2) Negligible surface evaporation for Case 1, (3) Constant properties, (4) Water vapor is saturated for Case 2 surface and may be approximated as a perfect gas.

**PROPERTIES:** Air (given):  $\nu = 1.6 \times 10^{-5} \text{ m}^2/\text{s}$ ,  $k = 0.026 \text{ W/m}\cdot\text{K}$ ,  $Pr = 0.70$ ; Water vapor - air (given):  $D_{AB} = 2.3 \times 10^{-5} \text{ m}^2/\text{s}$ ; Table A-6, Saturated water vapor ( $T_\infty = 303\text{K}$ ):

$$\rho_{A,\text{sat}} = \nu_g^{-1} = 0.030 \text{ kg/m}^3; \quad (T_s = 308\text{K}): \rho_{A,\text{sat}} = \nu_g^{-1} = 0.039 \text{ kg/m}^3, \quad h_{fg} = 2419 \text{ kJ/kg.}$$

**ANALYSIS:** (a) With  $Re_{L,2} = Re_{L,1}$  and  $Sc = \nu/D_{AB} = 1.6 \times 10^{-5} \text{ m}^2/\text{s} / 2.3 \times 10^{-5} \text{ m}^2/\text{s} = 0.70 = Pr$ , it follows that  $\overline{Sh}_L = \overline{Nu}_L$ . Hence

$$\begin{aligned} \overline{h}_m L / D_{AB} &= \overline{h} L / k \\ \overline{h}_m &= \overline{h} \frac{D_{AB}}{k} = \frac{q_1}{A_s (T_s - T_\infty)_1} \frac{D_{AB}}{k} = \frac{500 \text{ W}}{A_s (20\text{K})} \frac{2.3 \times 10^{-5} \text{ m}^2/\text{s}}{0.026 \text{ W/m}\cdot\text{K}} = \left[ \frac{0.0221}{A_s} \right] \text{ m/s.} \end{aligned}$$

Hence, from the rate equation, with  $A_s$  as the wetted surface

$$n_A = \overline{h}_m A_s (\rho_{A,s} - \rho_{A,\infty}) = \left[ \frac{0.0221}{A_s} \right] \frac{\text{m}}{\text{s}} A_s \left[ \rho_{A,\text{sat}}(T_{s,2}) - \phi_\infty \rho_{A,\text{sat}}(T_{\infty,2}) \right]$$

$$n_A = 0.0221 \text{ m}^3/\text{s} (0.039 - 0.6 \times 0.030) \text{ kg/m}^3 = 4.64 \times 10^{-4} \text{ kg/s.} \quad <$$

(b) The total heat loss for Case 2 is comprised of sensible and latent contributions, where

$$q_2 = q_{\text{sen}} + q_{\text{lat}} = \overline{h} A_s (T_{s,2} - T_{\infty,2}) + n_A h_{fg}.$$

Hence, with  $\overline{h} A_s = q_1 / (T_{s,1} - T_{\infty,1}) = 25 \text{ W/K}$ ,

$$q_2 = 25 \text{ W/K} (35 - 30)^\circ \text{C} + 4.64 \times 10^{-4} \text{ kg/s} \times 2.419 \times 10^6 \text{ J/kg}$$

$$q_2 = 125 \text{ W} + 1122 \text{ W} = 1247 \text{ W.} \quad <$$

**COMMENTS:** Note the significance of the evaporative cooling effect.



## PROBLEM 6.61

**KNOWN:** Heat transfer results for an irregularly shaped object.

**FIND:** (a) The concentration,  $C_A$ , and partial pressure,  $p_A$ , of vapor in an airstream for a drying process of an object of similar shape, (b) Average mass transfer flux,  $n''_A$  ( $\text{kg/s} \cdot \text{m}^2$ ).

**SCHEMATIC:**

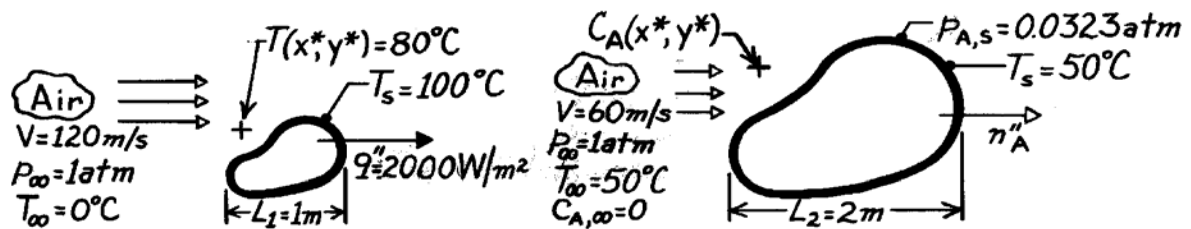

Case 1: Heat Transfer

Case 2: Mass Transfer

**ASSUMPTIONS:** (1) Heat-mass transfer analogy applies, (b) Perfect gas behavior.

**PROPERTIES:** Table A-4, Air (323K, 1 atm):  $\nu = 18.20 \times 10^{-6} \text{ m}^2/\text{s}$ ,  $\text{Pr} = 0.703$ ,  $k = 28.0 \times 10^{-3} \text{ W/m} \cdot \text{K}$ ; Plastic vapor (given):  $\mathcal{M}_A = 82 \text{ kg/kmol}$ ,  $p_{\text{sat}}(50^\circ\text{C}) = 0.0323 \text{ atm}$ ,  $D_{AB} = 2.6 \times 10^{-5} \text{ m}^2/\text{s}$ .

**ANALYSIS:** (a) Calculate Reynolds numbers

$$\text{Re}_1 = \frac{V_1 L_1}{\nu} = \frac{120 \text{ m/s} \times 1 \text{ m}}{18.2 \times 10^{-6} \text{ m}^2/\text{s}} = 6.59 \times 10^6$$

$$\text{Re}_2 = \frac{60 \text{ m/s} \times 2 \text{ m}}{18.2 \times 10^{-6} \text{ m}^2/\text{s}} = 6.59 \times 10^6.$$

Note that

$$\text{Pr}_1 = 0.703 \quad \text{Sc}_2 = \frac{\nu}{D_{AB}} = \frac{18.2 \times 10^{-6} \text{ m}^2/\text{s}}{2.6 \times 10^{-5} \text{ m}^2/\text{s}} = 0.700.$$

Since  $\text{Re}_1 = \text{Re}_2$  and  $\text{Pr}_1 = \text{Sc}_2$ , the dimensionless solutions to the energy and species equations are identical. That is, from Eqs. 6.47 and 6.51,

$$T^*(x^*, y^*) = C_A^*(x^*, y^*)$$

$$\frac{T - T_s}{T_\infty - T_s} = \frac{C_A - C_{A,s}}{C_{A,\infty} - C_{A,s}} \quad (1)$$

where  $T^*$  and  $C_A^*$  are defined by Eqs. 6.33 and 6.34, respectively. Now, determine

$$C_{A,s} = \frac{p_{A,\text{sat}}}{\mathcal{R}T} = \left( 0.0323 \text{ atm} / 8.205 \times 10^{-2} \text{ m}^3 \cdot \text{atm/kmol} \cdot \text{K} \times (273 + 50) \text{ K} \right)$$

$$C_{A,s} = 1.219 \times 10^{-3} \text{ kmol/kg}.$$

Continued ...

**PROBLEM 6.61 (Cont.)**

Substituting numerical values in Eq. (1),

$$C_A = C_{A,s} + (C_{A,\infty} - C_{A,s}) \frac{T - T_s}{T_\infty - T_s}$$

$$C_A = 1.219 \times 10^{-3} \text{ kmol/m}^3 + (0 - 1.219 \times 10^{-3}) \text{ kmol/m}^3 \frac{(80 - 100)^\circ \text{C}}{(0 - 100)^\circ \text{C}}$$

$$C_A = 0.975 \times 10^{-3} \text{ kmol/m}^3. \quad <$$

The vapor pressure is then

$$p_A = C_A \mathcal{R}T = 0.0258 \text{ atm.} \quad <$$

(b) For case 1,  $q'' = 2000 \text{ W/m}^2$ . The rate equations are

$$q'' = \bar{h}(T_s - T_\infty) \quad (2)$$

$$n''_A = \bar{h}_m(C_{A,s} - C_{A,\infty})\mathcal{M}_A. \quad (3)$$

From the analogy

$$\overline{\text{Nu}}_L = \overline{\text{Sh}}_L \quad \rightarrow \quad \frac{\bar{h}L_1}{k} = \frac{\bar{h}_m L_2}{D_{AB}} \quad \text{or} \quad \frac{\bar{h}}{\bar{h}_m} = \frac{L_2}{L_1} \frac{k}{D_{AB}}. \quad (4)$$

Combining Eqs. (2) - (4),

$$n''_A = q'' \frac{\bar{h}_m}{\bar{h}} \frac{(C_{A,s} - C_{A,\infty})\mathcal{M}_A}{(T_s - T_\infty)} = q'' \frac{L_1 D_{AB}}{L_2 k} \frac{(C_{A,s} - C_{A,\infty})\mathcal{M}_A}{(T_s - T_\infty)}$$

which numerically gives

$$n''_A = 2000 \text{ W/m}^2 \frac{1\text{m} (2.6 \times 10^{-5} \text{ m}^2/\text{s})}{2\text{m} (28 \times 10^{-3} \text{ W/m} \cdot \text{K})} \frac{(1.219 \times 10^{-3} - 0) \text{ kmol/m}^3 (82 \text{ kg/kmol})}{(100 - 0) \text{ K}}$$

$$n''_A = 9.28 \times 10^{-4} \text{ kg/s} \cdot \text{m}^2. \quad <$$

**COMMENTS:** Recognize that the analogy between heat and mass transfer applies when the conservation equations and boundary conditions are of the same form.

### PROBLEM 6.62

**KNOWN:** Convection heat transfer correlation for flow over a contoured surface.

**FIND:** (a) Evaporation rate from a water film on the surface, (b) Steady-state film temperature.

**SCHEMATIC:**

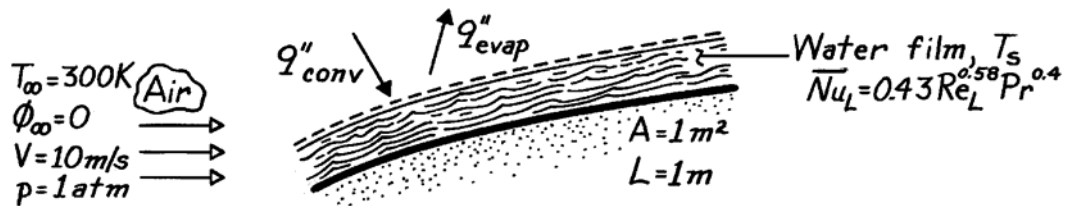

**ASSUMPTIONS:** (1) Steady-state conditions, (b) Constant properties, (c) Negligible radiation, (d) Heat and mass transfer analogy is applicable.

**PROPERTIES:** Table A-4, Air (300K, 1 atm):  $k = 0.0263 \text{ W/m}\cdot\text{K}$ ,  $\nu = 15.89 \times 10^{-6} \text{ m}^2/\text{s}$ ,  $\text{Pr} = 0.707$ ; Table A-6, Water ( $T_s \approx 280\text{K}$ ):  $v_g = 130.4 \text{ m}^3/\text{kg}$ ,  $h_{fg} = 2485 \text{ kJ/kg}$ ; Table A-8, Water-air ( $T \approx 298\text{K}$ ):  $D_{AB} = 0.26 \times 10^{-4} \text{ m}^2/\text{s}$ .

**ANALYSIS:** (a) The mass evaporation rate is

$$\dot{m}_{\text{evap}} = n_A = \bar{h}_m A \left[ \rho_{A,\text{sat}}(T_s) - \phi_{\infty} \rho_{A,\text{sat}}(T_{\infty}) \right] = \bar{h}_m A \rho_{A,\text{sat}}(T_s).$$

From the heat and mass transfer analogy:  $\bar{\text{Sh}}_L = 0.43 \text{Re}_L^{0.58} \text{Sc}^{0.4}$

$$\text{Re}_L = \frac{VL}{\nu} = \frac{(10 \text{ m/s}) 1 \text{ m}}{15.89 \times 10^{-6} \text{ m}^2/\text{s}} = 6.29 \times 10^5 \quad \text{Sc} = \frac{\nu}{D_{AB}} = \frac{15.89 \times 10^{-6} \text{ m}^2/\text{s}}{26 \times 10^{-6} \text{ m}^2/\text{s}} = 0.61$$

$$\bar{\text{Sh}}_L = 0.43 \left( 6.29 \times 10^5 \right)^{0.58} (0.61)^{0.4} = 814$$

$$\bar{h}_m = \frac{D_{AB}}{L} \bar{\text{Sh}}_L = \frac{0.26 \times 10^{-4} \text{ m}^2/\text{s}}{1 \text{ m}} (814) = 0.0212 \text{ m/s}$$

$$\rho_{A,\text{sat}}(T_s) = v_g(T_s)^{-1} = 0.0077 \text{ kg/m}^3.$$

$$\text{Hence, } \dot{m}_{\text{evap}} = 0.0212 \text{ m/s} \times 1 \text{ m}^2 \times 0.0077 \text{ kg/m}^3 = 1.63 \times 10^{-4} \text{ kg/s.} \quad <$$

(b) From a surface energy balance,  $q''_{\text{conv}} = q''_{\text{evap}}$ , or

$$\bar{h}_L (T_{\infty} - T_s) = \dot{m}_{\text{evap}}'' h_{fg} \quad T_s = T_{\infty} - \frac{(\dot{m}_{\text{evap}}'' h_{fg})}{\bar{h}_L}.$$

$$\text{With } \bar{\text{Nu}}_L = 0.43 \left( 6.29 \times 10^5 \right)^{0.58} (0.707)^{0.4} = 864$$

$$\bar{h}_L = \frac{k}{L} \bar{\text{Nu}}_L = \frac{0.0263 \text{ W/m}\cdot\text{K}}{1 \text{ m}} 864 = 22.7 \text{ W/m}^2 \cdot \text{K}.$$

$$\text{Hence, } T_s = 300\text{K} - \frac{1.63 \times 10^{-4} \text{ kg/s} \cdot \text{m}^2 (2.485 \times 10^6 \text{ J/kg})}{22.7 \text{ W/m}^2 \cdot \text{K}} = 282.2\text{K.} \quad <$$

**COMMENTS:** The saturated vapor density,  $\rho_{A,\text{sat}}$ , is strongly temperature dependent, and if the initial guess of  $T_s$  needed for its evaluation differed from the above result by more than a few degrees, the density would have to be evaluated at the new temperature and the calculations repeated.

### PROBLEM 6.63

**KNOWN:** Dimensions of rectangular naphthalene rod. Velocity and temperature of air flow. Molecular weight and saturation pressure of naphthalene.

**FIND:** Mass loss after 30 minutes.

**SCHEMATIC:**

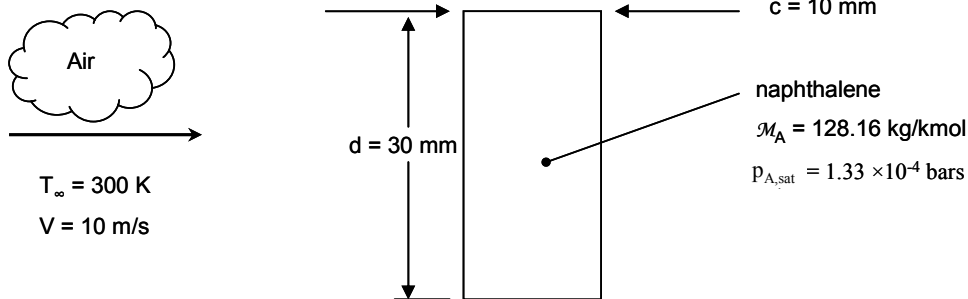

**ASSUMPTIONS:** (1) Constant properties, (2) Mass loss is small, so dimensions remain unchanged, (3) Viscosity of air-naphthalene mixture is approximately that of air.

**PROPERTIES:** Table A-4, Air (300 K):  $\nu = 15.89 \times 10^{-6} \text{ m}^2/\text{s}$ . Table A-8, Naphthalene in air, (300 K):  $D_{AB} = 0.62 \times 10^{-5} \text{ m}^2/\text{s}$ ,  $Sc = \nu/D_{AB} = 2.56$ .

**ANALYSIS:** We will use the heat and mass transfer analogy, with the Nusselt number correlation known from Problem 6.10 to be of the form

$$Nu_d = CRe_d^m Pr^{1/3}$$

Then invoking Equation 6.59,

$$Sh_d = CRe_d^m Sc^{1/3} = h_m d / D_{AB}$$

Now  $Re_d = Vd/\nu = 10 \text{ m/s} \times 0.03 \text{ m} / 15.89 \times 10^{-6} \text{ m}^2/\text{s} = 18,880$ . We find the values of  $C$  and  $m$  from Problem 6.10 with  $c/d = 0.33$ , for the front, sides, and back of the rod:

	$C$	$m$	$Sh_d$	$h_m(\text{m/s})$
front	0.674	1/2	126.7	0.0262
sides	0.153	2/3	148.5	0.0307
back	0.174	2/3	168.8	0.0349

The average mass transfer coefficient is

$$\begin{aligned} \bar{h}_m &= (h_{m,\text{front}}d + 2h_{m,\text{side}}c + h_{m,\text{back}}d)/(2d + 2c) \\ &= \frac{0.0262 \text{ m/s} \times 0.03 \text{ m} + 2 \times 0.0307 \text{ m/s} \times 0.01 \text{ m} + 0.0349 \text{ m/s} \times 0.03 \text{ m}}{2 \times 0.03 \text{ m} + 2 \times 0.01 \text{ m}} \\ &= 0.0306 \text{ m/s} \end{aligned}$$

Then the mass loss can be found from

$$\Delta m = n_A \Delta t = \bar{h}_m A_{\text{tot}} (\rho_{A,s} - \rho_{A,\infty}) \Delta t$$

Continued...

### PROBLEM 6.63 (Cont.)

Here  $\rho_{A,\infty} = 0$  and  $\rho_{A,s}$  can be found from the saturation pressure, using the ideal gas law:

$$\begin{aligned}\rho_{A,s} &= \frac{P_{A,\text{sat}}}{R_1 T_s} = \frac{P_{A,\text{sat}} \mathcal{M}_A}{\mathcal{R} T_s} \\ &= \frac{1.33 \times 10^{-4} \text{ bar} \times 128.16 \text{ kg/kmol}}{8.314 \times 10^{-2} \text{ m}^3 \cdot \text{bar/kmol} \cdot \text{K} \times 300 \text{ K}} \\ &= 6.83 \times 10^{-4} \text{ kg/m}^3\end{aligned}$$

Thus, finally,

$$\begin{aligned}\Delta m &= 0.0306 \text{ m/s} \times (2 \times 0.03 \text{ m} + 2 \times 0.01 \text{ m}) \times 0.5 \text{ m} \\ &\quad \times (6.83 \times 10^{-4} - 0) \text{ kg/m}^3 \times 30 \text{ min} \times 60 \text{ s/min} \\ &= 1.50 \times 10^{-3} \text{ kg}\end{aligned}$$

<

**COMMENTS:** The average depth of surface recession is given by  $\delta = \overline{h}_m (\rho_{A,s} - \rho_{A,\infty}) \Delta t / \rho_{A,\text{sol}}$  where  $\rho_{A,\text{sol}}$  is the density of solid naphthalene,  $\rho_{A,\text{sol}} = 1025 \text{ kg/m}^3$ . Thus  $\delta = 37 \text{ } \mu\text{m}$  and the assumption that the dimensions remain unchanged is good.

## PROBLEM 6.64

**KNOWN:** Surface area and temperature of a coated turbine blade. Temperature and pressure of air flow over the blade. Molecular weight and saturation vapor pressure of the naphthalene coating. Duration of air flow and corresponding mass loss of naphthalene due to sublimation.

**FIND:** Average convection heat transfer coefficient.

**SCHEMATIC:**

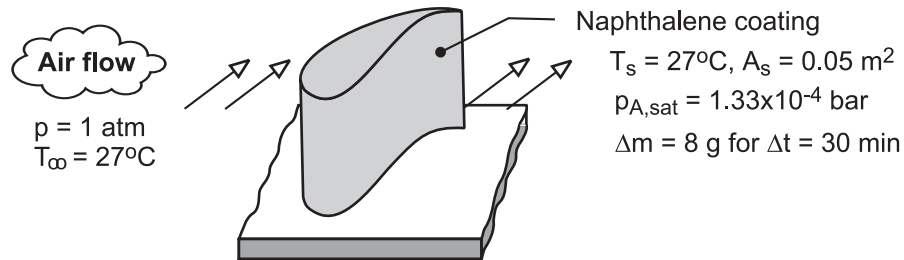

**ASSUMPTIONS:** (1) Applicability of heat and mass transfer analogy, (2) Negligible change in  $A_s$  due to mass loss, (3) Naphthalene vapor behaves as an ideal gas, (4) Solid/vapor equilibrium at surface of coating, (5) Negligible vapor density in freestream of air flow.

**PROPERTIES:** Table A-4, Air ( $T = 300\text{K}$ ):  $\rho = 1.161 \text{ kg/m}^3$ ,  $c_p = 1007 \text{ J/kg}\cdot\text{K}$ ,  $\alpha = 22.5 \times 10^{-6} \text{ m}^2/\text{s}$ . Table A-8, Naphthalene vapor/air ( $T = 300\text{K}$ ):  $D_{AB} = 0.62 \times 10^{-5} \text{ m}^2/\text{s}$ .

**ANALYSIS:** From the rate equation for convection mass transfer, the average convection mass transfer coefficient may be expressed as

$$\bar{h}_m = \frac{n_A}{A_s (\rho_{A,s} - \rho_{A,\infty})} = \frac{\Delta m / \Delta t}{A_s \rho_{A,s}}$$

where

$$\rho_{A,s} = \rho_{A,\text{sat}}(T_s) = \frac{M_A p_{A,\text{sat}}}{\mathcal{R} T_s} = \frac{(128.16 \text{ kg/kmol}) 1.33 \times 10^{-4} \text{ bar}}{0.08314 \text{ m}^3 \cdot \text{bar/kmol} \cdot \text{K} (300\text{K})} = 6.83 \times 10^{-4} \text{ kg/m}^3$$

Hence,

$$\bar{h}_m = \frac{0.008 \text{ kg} / (30 \text{ min} \times 60 \text{ s/min})}{0.05 \text{ m}^2 (6.83 \times 10^{-4} \text{ kg/m}^3)} = 0.13 \text{ m/s}$$

Using the heat and mass transfer analogy with  $n = 1/3$ , we then obtain

$$\begin{aligned} \bar{h} &= \bar{h}_m \rho c_p \text{Le}^{2/3} = \bar{h}_m \rho c_p \left( \frac{\alpha}{D_{AB}} \right)^{2/3} = 0.130 \text{ m/s} (1.161 \text{ kg/m}^3) \times \\ & 1007 \text{ J/kg} \cdot \text{K} \left( 22.5 \times 10^{-6} / 0.62 \times 10^{-5} \right)^{2/3} = 359 \text{ W/m}^2 \cdot \text{K} \end{aligned} \quad <$$

**COMMENTS:** The naphthalene sublimation technique has been used extensively to determine convection coefficients associated with complex flows and geometries.

## PROBLEM 6.65

**KNOWN:** Half-scale naphthalene model of human head. Velocity and temperature of air flow while skiing. Temperature of air in wind tunnel. Depth of recession after 120 min for three locations. Density of solid naphthalene.

**FIND:** (a) Required wind tunnel velocity, (b) Heat transfer coefficients for full-scale head in skiing conditions, (c) Explain if uncovered regions would have same heat transfer coefficient when headgear is in place.

**SCHEMATIC:**

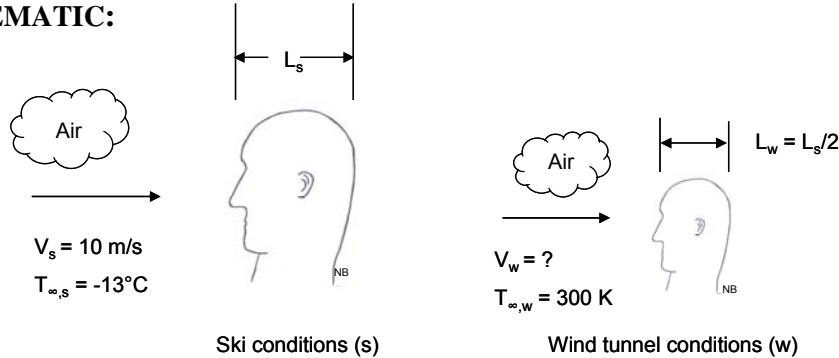

**ASSUMPTIONS:** (1) Constant properties, (2) Pr and Sc are raised to the one-third power in the heat and mass transfer correlations, (3) The properties of the air-naphthalene mixture are approximately those of air, (4) Properties can be evaluated at  $T_\infty$  under the skiing conditions.

**PROPERTIES:** Table A-4, Air ( $-13^\circ\text{C} = 260\text{ K}$ ):  $\nu = 12.33 \times 10^{-6}\text{ m}^2/\text{s}$ ,  $k = 23.1 \times 10^{-3}\text{ W/m}\cdot\text{K}$ . Air (300 K):  $\rho = 1.161\text{ kg/m}^3$ ,  $c_p = 1007\text{ J/kg}\cdot\text{K}$ ,  $\nu = 15.89 \times 10^{-6}\text{ m}^2/\text{s}$ ,  $k = 26.3 \times 10^{-3}\text{ W/m}\cdot\text{K}$ ,  $\alpha = 22.5 \times 10^{-6}\text{ m}^2/\text{s}$ . Table A-8, Naphthalene in air, (300 K):  $D_{AB} = 0.62 \times 10^{-5}\text{ m}^2/\text{s}$ .

**ANALYSIS:** (a) In order for the results of the wind tunnel test to be directly applicable to the skiing conditions, the Reynolds numbers must be the same:

$$\text{Re}_s = \text{Re}_w \quad V_s L_s / \nu_s = V_w L_w / \nu_w$$

$$V_w = V_s \frac{L_s}{L_w} \frac{\nu_w}{\nu_s} = 10\text{ m/s} \times 2 \times \frac{15.89 \times 10^{-6}\text{ m}^2/\text{s}}{12.33 \times 10^{-6}\text{ m}^2/\text{s}} = 25.8\text{ m/s} \quad <$$

(b) The mass flux and mass transfer coefficient can be found from knowledge of the recession depth:

$$n''_A = \rho_{A,\text{sol}} \delta / \Delta t$$

$$h_m = n''_A / (\rho_{A,s} - \rho_{A,\infty}) = \rho_{A,\text{sol}} \delta / (\rho_{A,s} - \rho_{A,\infty}) \Delta t$$

where  $\rho_{A,\infty} = 0$  and  $\rho_{A,s}$  can be found from the saturation pressure and molecular weight (see Problem 6.63) using the ideal gas law.

$$\rho_{A,s} = \frac{\rho_{A,\text{sat}} \mathcal{M}_A}{\mathcal{R} T_s} = \frac{1.33 \times 10^{-4}\text{ bars} \times 128.16\text{ kg/kmol}}{8.314 \times 10^{-2}\text{ m}^3 \cdot \text{bar/kmol} \cdot \text{K} \times 300\text{ K}} = 6.83 \times 10^{-4}\text{ kg/m}^3 \quad <$$

Continued...

### PROBLEM 6.65 (Cont.)

Thus, with  $\delta_1 = 0.1$  mm,

$$h_{m,1} = 1025 \text{ kg/m}^3 \times 10^{-4} \text{ m} / (6.83 \times 10^{-4} \text{ kg/m}^3 \times 120 \text{ min} \times 60 \text{ s/min}) = 2.08 \times 10^{-2} \text{ m/s}$$

Similarly for the other two locations,

$$h_{m,2} = 6.67 \times 10^{-2} \text{ m/s}, \quad h_{m,3} = 1.33 \times 10^{-1} \text{ m/s}$$

The heat transfer coefficients can then be found from the heat and mass transfer analogy as stated in Equation 6.60.

$$h = h_m \rho c_p Le^{1-n}$$

where  $n = 1/3$  and

$$Le = \alpha / D_{AB} = (22.5 \times 10^{-6} \text{ m}^2/\text{s}) / (0.62 \times 10^{-5} \text{ m}^2/\text{s}) = 3.63$$

Thus at location 1,

$$h_1 = 2.08 \times 10^{-2} \text{ m/s} \times 1.161 \text{ kg/m}^3 \times 1007 \text{ J/kg} \cdot \text{K} \times (3.63)^{2/3} = 57.4 \text{ W/m}^2 \cdot \text{K}$$

And for the other two locations,

$$h_2 = 184 \text{ W/m}^2 \cdot \text{K}, \quad h_3 = 368 \text{ W/m}^2 \cdot \text{K}$$

These values are for the half-scale model. Since the Reynolds number is the same in the wind tunnel as in the skiing conditions, the local Nusselt numbers are also the same (see Equation 6.49), thus

$$\begin{aligned} Nu_s &= Nu_w & h_s L_s / k_s &= h_w L_w / k_w \\ h_s &= h_w \frac{L_w}{L_s} \frac{k_s}{k_w} = h_w \times 1/2 \times \frac{23.1 \times 10^{-3} \text{ W/m} \cdot \text{K}}{26.3 \times 10^{-3} \text{ W/m} \cdot \text{K}} \end{aligned}$$

Thus

$$h_{s1} = h_{w1} \times 0.439 = 57.4 \text{ W/m}^2 \cdot \text{K} \times 0.439 = 25.2 \text{ W/m}^2 \cdot \text{K} \quad <$$

And similarly

$$h_{s,2} = 80.8 \text{ W/m}^2 \cdot \text{K}, \quad h_{s,3} = 162 \text{ W/m}^2 \cdot \text{K} \quad <$$

(c) When the headgear is in place, it will change the geometry of the surface and therefore change the heat transfer coefficients. The regions that are left uncovered will be recessed relative to the rest of the surface. This will probably reduce the local velocity near the surface slightly and reduce the local heat transfer coefficient.

COMMENTS: (1) The properties should be evaluated at the *film temperature*,  $T_f = (T_s + T_\infty)/2$ . In the wind tunnel the conditions are isothermal, but in the ski conditions they are not. However the surface temperature is unknown and cannot be found without a more complex analysis of heat transfer in the body and the headgear (when present). (2) Heat loss is not the only consideration when designing winter clothing. Comfort is also important and exposed areas could be uncomfortably cold, even though areas with small heat transfer coefficients will be warmer than those with larger coefficients.



## PROBLEM 6.66

**KNOWN:** Mass transfer experimental results on a half-sized model representing an engine strut.

**FIND:** (a) The coefficients  $C$  and  $m$  of the correlation  $\overline{Sh}_L = C Re_L^m Sc^{1/3}$  for the mass transfer results, (b) Average heat transfer coefficient,  $\bar{h}$ , for the full-sized strut with prescribed operating conditions, (c) Change in total heat rate if characteristic length  $L_H$  is doubled.

**SCHEMATIC:**

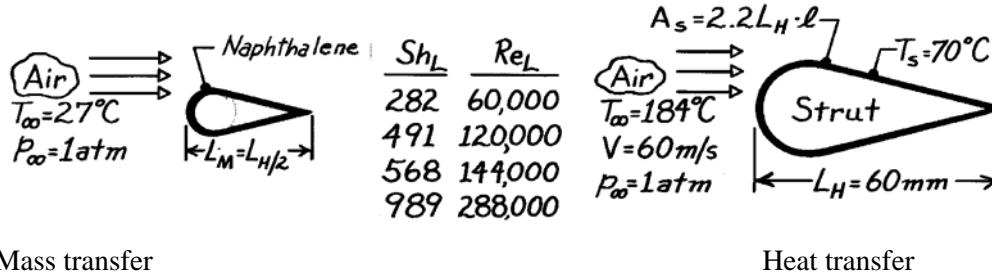

Mass transfer

Heat transfer

**ASSUMPTIONS:** Analogy exists between heat and mass transfer.

**PROPERTIES:** Table A-4, Air ( $\bar{T} = (T_\infty + T_s)/2 = 400\text{K}$ , 1 atm):  $\nu = 26.41 \times 10^{-6} \text{ m}^2/\text{s}$ ,  $k = 0.0338 \text{ W/m}\cdot\text{K}$ ,  $Pr = 0.690$ ; ( $\bar{T} = 300\text{K}$ ):  $\nu_B = 15.89 \times 10^{-6} \text{ m}^2/\text{s}$ ; Table A-8, Naphthalene-air (300K, 1 atm):  $D_{AB} = 0.62 \times 10^{-5} \text{ m}^2/\text{s}$ ,  $Sc = \nu_B/D_{AB} = 15.89 \times 10^{-6} \text{ m}^2/\text{s} / 0.62 \times 10^{-5} \text{ m}^2/\text{s} = 2.56$ .

**ANALYSIS:** (a) The correlation for the mass transfer experimental results is of the form  $\overline{Sh}_L = C Re_L^m Sc^{1/3}$ . The constants  $C, m$  may be evaluated from two data sets of  $\overline{Sh}_L$  and  $Re_L$ ; choosing the middle sets (2,3):

$$\frac{(\overline{Sh}_L)_2}{(\overline{Sh}_L)_3} = \frac{(Re_L)_2^m}{(Re_L)_3^m} \quad \text{or} \quad m = \frac{\log [(\overline{Sh}_L)_2 / (\overline{Sh}_L)_3]}{\log [(Re_L)_2 / (Re_L)_3]} = \frac{\log [491/568]}{\log [120,000/144,000]} = 0.80. \quad <$$

$$\text{Then, using set 2, find } C = \frac{(\overline{Sh}_L)_2}{(Re_L)_2^m Sc^{1/3}} = \frac{491}{(120,000)^{0.8} 2.56^{1/3}} = 0.031. \quad <$$

(b) For the heat transfer analysis of the strut, the correlation will be of the form  $\overline{Nu}_L = \bar{h}_L \cdot L_H / k = 0.031 Re_L^{0.8} Pr^{1/3}$  where  $Re_L = V L_H / \nu$  and the constants  $C, m$  were determined in Part (a). Substituting numerical values,

$$\bar{h}_L = \overline{Nu}_L \cdot \frac{k}{L_H} = 0.031 \left[ \frac{60 \text{ m/s} \times 0.06 \text{ m}}{26.41 \times 10^{-6} \text{ m}^2/\text{s}} \right]^{0.8} 0.690^{1/3} \frac{0.0338 \text{ W/m}\cdot\text{K}}{0.06 \text{ m}} = 198 \text{ W/m}^2 \cdot \text{K}. \quad <$$

(c) The total heat rate for the strut of characteristic length  $L_H$  is  $q = \bar{h} A_s (T_s - T_\infty)$ , where  $A_s = 2.2 L_H l$  and

$$\bar{h} \sim \overline{Nu}_L \cdot L_H^{-1} \sim Re_L^{0.8} \cdot L_H^{-1} \sim L_H^{0.8} \cdot L_H^{-1} \sim L_H^{-0.2} \quad A_s \sim L_H$$

Hence,  $q \sim \bar{h} \cdot A_s \sim (L_H^{-0.2}) (L_H) \sim L_H^{0.8}$ . If the characteristic length were doubled, the heat rate

would be increased by a factor of  $(2)^{0.8} = 1.74$ . <

### PROBLEM 6.67

**KNOWN:** Boundary layer temperature distribution for flow of dry air over water film.

**FIND:** Evaporative mass flux and whether net energy transfer is to or from the water.

**SCHEMATIC:**

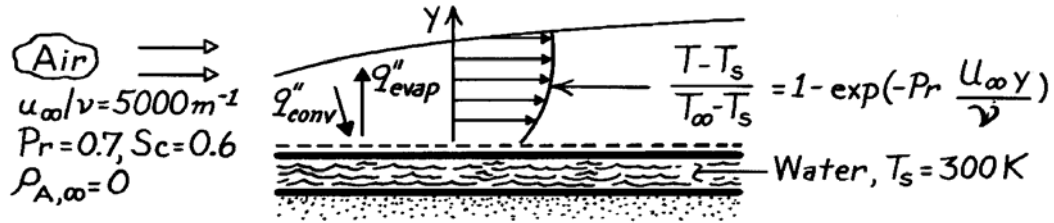

**ASSUMPTIONS:** (1) Heat and mass transfer analogy is applicable, (2) Water is well insulated from below.

**PROPERTIES:** Table A-4, Air ( $T_s = 300\text{K}$ , 1 atm):  $k = 0.0263\text{ W/m}\cdot\text{K}$ ; Table A-6, Water vapor ( $T_s = 300\text{K}$ ):  $\rho_{A,s} = v_g^{-1} = 0.0256\text{ kg/m}^3$ ,  $h_{fg} = 2.438 \times 10^6\text{ J/kg}$ ; Table A-8, Air-water vapor ( $T_s = 300\text{K}$ ):  $D_{AB} = 0.26 \times 10^{-4}\text{ m}^2/\text{s}$ .

**ANALYSIS:** From the heat and mass transfer analogy,

$$\frac{\rho_A - \rho_{A,s}}{\rho_{A,\infty} - \rho_{A,s}} = 1 - \exp\left[-Sc \frac{u_\infty y}{\nu}\right].$$

Using Fick's law at the surface ( $y = 0$ ), the species flux is

$$n''_A = -D_{AB} \left. \frac{\partial \rho_A}{\partial y} \right|_{y=0} = +\rho_{A,s} D_{AB} Sc \frac{u_\infty}{\nu}$$

$$n''_A = 0.0256\text{ kg/m}^3 \times 0.26 \times 10^{-4}\text{ m}^2/\text{s} \times (0.6) 5000\text{ m}^{-1} = 2.00 \times 10^{-3}\text{ kg/s}\cdot\text{m}^2.$$

The net heat flux to the water has the form

$$q''_{\text{net}} = q''_{\text{conv}} - q''_{\text{evap}} = +k \left. \frac{\partial T}{\partial y} \right|_{y=0} - n''_A h_{fg} = k(T_\infty - T_s) Pr \frac{u_\infty}{\nu} - n''_A h_{fg}$$

and substituting numerical values, find

$$q''_{\text{net}} = 0.0263 \frac{\text{W}}{\text{m}\cdot\text{K}} (100\text{K}) 0.7 \times 5000\text{ m}^{-1} - 2 \times 10^{-3} \frac{\text{kg}}{\text{s}\cdot\text{m}^2} \times 2.438 \times 10^6\text{ J/kg}$$

$$q''_{\text{net}} = 9205\text{ W/m}^2 - 4876\text{ W/m}^2 = 4329\text{ W/m}^2.$$

Since  $q''_{\text{net}} > 0$ , the net heat transfer is to the water. <

**COMMENTS:** Note use of properties ( $D_{AB}$  and  $k$ ) evaluated at  $T_s$  to determine surface fluxes.

### PROBLEM 6.68

**KNOWN:** Distribution of local convection heat transfer coefficient for obstructed flow over a flat plate with surface and air temperatures of 310K and 290K, respectively.

**FIND:** Average convection mass transfer coefficient.

**SCHEMATIC:**

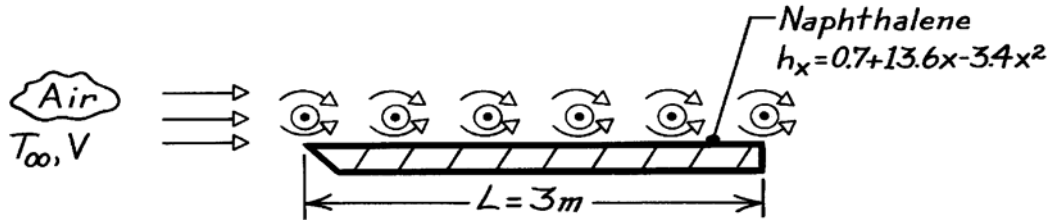

**ASSUMPTIONS:** Heat and mass transfer analogy is applicable.

**PROPERTIES:** Table A-4, Air ( $T_f = (T_s + T_\infty)/2 = (310 + 290)\text{ K}/2 = 300\text{ K}$ , 1 atm):

$k = 0.0263\text{ W/m}\cdot\text{K}$ ,  $\nu = 15.89 \times 10^{-6}\text{ m}^2/\text{s}$ ,  $\text{Pr} = 0.707$ . Table A-8, Air-naphthalene (300K, 1 atm):  $D_{AB} = 0.62 \times 10^{-5}\text{ m}^2/\text{s}$ ,  $\text{Sc} = \nu/D_{AB} = 2.56$ .

**ANALYSIS:** The average heat transfer coefficient is

$$\bar{h}_L = \frac{1}{L} \int_0^L h_x dx = \frac{1}{L} \int_0^L (0.7 + 13.6x - 3.4x^2) dx$$

$$\bar{h}_L = 0.7 + 6.8L - 1.13L^2 = 10.9\text{ W/m}^2 \cdot \text{K}$$

Applying the heat and mass transfer analogy with  $n = 1/3$ , Equation 6.59 yields

$$\frac{\overline{\text{Nu}}_L}{\text{Pr}^{1/3}} = \frac{\overline{\text{Sh}}_L}{\text{Sc}^{1/3}}$$

Hence,

$$\frac{\bar{h}_{m,L} L}{D_{AB}} = \frac{\bar{h}_L L}{k} \frac{\text{Sc}^{1/3}}{\text{Pr}^{1/3}}$$

$$\bar{h}_{m,L} = \bar{h}_L \frac{D_{AB}}{k} \frac{\text{Sc}^{1/3}}{\text{Pr}^{1/3}} = 10.9\text{ W/m}^2 \cdot \text{K} \frac{0.62 \times 10^{-5}\text{ m}^2/\text{s}}{0.0263\text{ W/m}\cdot\text{K}} \left( \frac{2.56}{0.707} \right)^{1/3}$$

$$\bar{h}_{m,L} = 0.00395\text{ m/s}$$

<

**COMMENTS:** The naphthalene sublimation method provides a useful tool for determining local convection coefficients.

### PROBLEM 6.69

**KNOWN:** Radial distribution of local Sherwood number for uniform flow normal to a circular disk.

**FIND:** (a) Expression for average Nusselt number. (b) Heat rate for prescribed conditions.

**SCHEMATIC:**

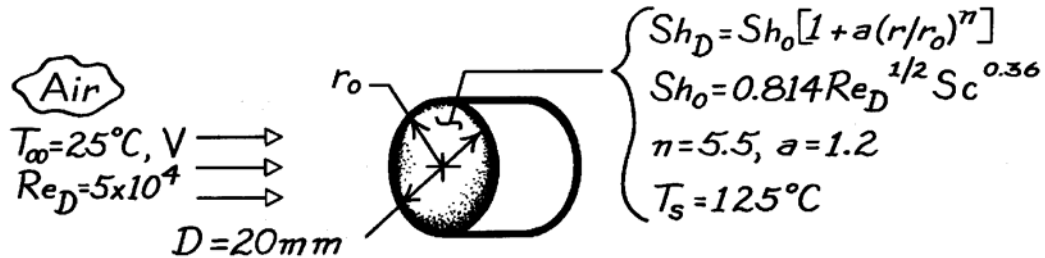

**ASSUMPTIONS:** (1) Constant properties, (2) Applicability of heat and mass transfer analogy.

**PROPERTIES:** Table A-4, Air ( $\bar{T} = 75^\circ\text{C} = 348\text{ K}$ ):  $k = 0.0299\text{ W/m}\cdot\text{K}$ ,  $\text{Pr} = 0.70$ .

**ANALYSIS:** (a) From the heat and mass transfer analogy, Equation 6.57,

$$\frac{\overline{\text{Nu}}_D}{\text{Pr}^{0.36}} = \frac{\overline{\text{Sh}}_D}{\text{Sc}^{0.36}}$$

where

$$\begin{aligned} \overline{\text{Sh}}_D &= \frac{1}{A_s} \int_{A_s} \text{Sh}_D(r) dA_s = \frac{\text{Sh}_0}{\pi r_0^2} 2\pi \int_0^{r_0} [1 + a(r/r_0)^n] r dr \\ \overline{\text{Sh}}_D &= \frac{2\text{Sh}_0}{r_0^2} \left[ \frac{r^2}{2} + \frac{a r^{n+2}}{(n+2)r_0^n} \right]_0^{r_0} = \text{Sh}_0 [1 + 2a/(n+2)] \end{aligned}$$

Hence,

$$\overline{\text{Nu}}_D = 0.814 [1 + 2a/(n+2)] \text{Re}_D^{1/2} \text{Pr}^{0.36} \quad <$$

(b) The heat rate for these conditions is

$$\begin{aligned} q &= \bar{h}A(T_s - T_\infty) = 0.814 [1 + 2a/(n+2)] \frac{k}{D} \text{Re}_D^{1/2} \text{Pr}^{0.36} \left( \frac{\pi D^2}{4} \right) (T_s - T_\infty) \\ q &= 0.814 (1 + 2.4/7.5) 0.0299\text{ W/m}\cdot\text{K} (\pi 0.02\text{ m}/4) (5 \times 10^4)^{1/2} (0.7)^{0.36} (100^\circ\text{C}) \\ q &= 9.92\text{ W} \quad < \end{aligned}$$

**COMMENTS:** The increase in  $h(r)$  with  $r$  may be explained in terms of the sharp turn which the boundary layer flow must make around the edge of the disk. The boundary layer accelerates and its thickness decreases as it makes the turn, causing the local convection coefficient to increase.

### PROBLEM 6.70

**KNOWN:** Convection heat transfer correlation for wetted surface of a sand grouse. Initial water content of surface. Velocity of bird and ambient air conditions.

**FIND:** Flight distance for depletion of 50% of initial water content.

**SCHEMATIC:**

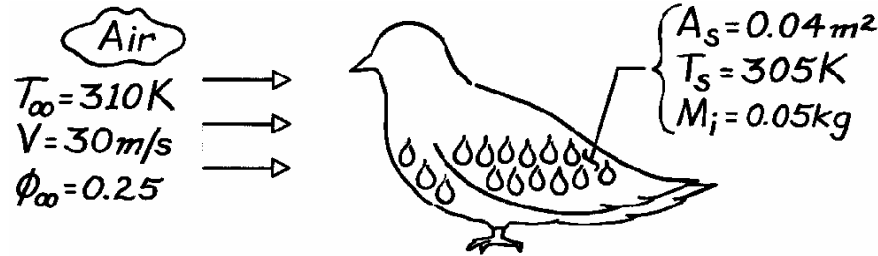

**ASSUMPTIONS:** (1) Steady-state conditions, (2) Vapor behaves as a perfect gas, (3) Constant properties, (4) Applicability of heat and mass transfer analogy.

**PROPERTIES:** Air (given):  $\nu = 16.7 \times 10^{-6} \text{ m}^2/\text{s}$ ; Air-water vapor (given):

$D_{AB} = 0.26 \times 10^{-4} \text{ m}^2/\text{s}$ ; Table A-6, Water vapor ( $T_s = 305 \text{ K}$ ):  $\nu_g = 29.74 \text{ m}^3/\text{kg}$ ; ( $T_s = 310 \text{ K}$ ),  $\nu_g = 22.93 \text{ m}^3/\text{kg}$ .

**ANALYSIS:** The maximum flight distance is

$$X_{\max} = V t_{\max}$$

where the time to deplete 50% of the initial water content  $\Delta M$  is

$$t_{\max} = \frac{\Delta M}{\dot{m}_{\text{evap}}} = \frac{\Delta M}{\bar{h}_m A_s (\rho_{A,s} - \rho_{A,\infty})}$$

The mass transfer coefficient is

$$\begin{aligned} \bar{h}_m &= \overline{\text{Sh}}_L \frac{D_{AB}}{L} = 0.034 \text{Re}_L^{4/5} \text{Sc}^{1/3} \frac{D_{AB}}{L} \\ \text{Sc} &= \nu/D_{AB} = 0.642, \quad L = (A_s)^{1/2} = 0.2 \text{ m} \\ \text{Re}_L &= \frac{VL}{\nu} = \frac{30 \text{ m/s} \times 0.2 \text{ m}}{16.7 \times 10^{-6} \text{ m}^2/\text{s}} = 3.59 \times 10^5 \\ \bar{h}_m &= 0.034 (3.59 \times 10^5)^{4/5} (0.642)^{1/3} (0.26 \times 10^{-4} \text{ m}^2/\text{s}/0.2 \text{ m}) = 0.106 \text{ m/s}. \end{aligned}$$

Hence,

$$t_{\max} = \frac{0.025 \text{ kg}}{0.106 \text{ m/s} (0.04 \text{ m}^2) \left[ (29.74)^{-1} - 0.25(22.93)^{-1} \right] \text{ kg/m}^3} = 259 \text{ s}$$

$$X_{\max} = 30 \text{ m/s} (259 \text{ s}) = 7785 \text{ m} = 7.78 \text{ km}. \quad <$$

**COMMENTS:** Evaporative heat loss is balanced by convection heat transfer from air.

Hence,  $T_s < T_\infty$ .

## PROBLEM 6.71

**KNOWN:** Water-soaked paper towel experiences simultaneous heat and mass transfer while subjected to parallel flow of air, irradiation from a radiant lamp bank, and radiation exchange with surroundings. Average convection coefficient estimated as  $\bar{h} = 28.7 \text{ W/m}^2 \cdot \text{K}$ .

**FIND:** (a) Rate at which water evaporates from the towel,  $n_A$  (kg/s), and (b) The net rate of radiation transfer,  $q_{\text{rad}}$  (W), to the towel. Determine the irradiation  $G$  ( $\text{W/m}^2$ ).

**SCHEMATIC:**

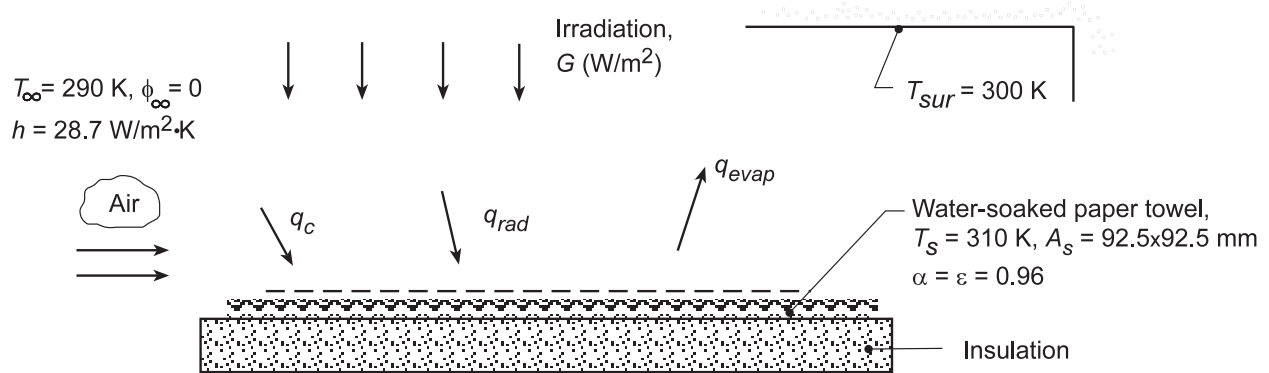

**ASSUMPTIONS:** (1) Steady-state conditions, (2) Vapor behaves as an ideal gas, (3) Constant properties, (4) Towel experiences radiation exchange with the large surroundings as well as irradiation from the lamps, (5) Negligible heat transfer from the bottom side of the towel, and (6) Applicability of the heat-mass transfer analogy.

**PROPERTIES:** Table A.4, Air ( $T_f = 300 \text{ K}$ ):  $\rho = 1.1614 \text{ kg/m}^3$ ,  $c_p = 1007 \text{ J/kg} \cdot \text{K}$ ,  $\alpha = 22.5 \times 10^{-6} \text{ m}^2/\text{s}$ ; Table A.6, Water (310 K):  $\rho_{A,s} = \rho_g = 1/v_g = 1/22.93 = 0.0436 \text{ kg/m}^3$ ,  $h_{fg} = 2414 \text{ kJ/kg}$ . Table A.8, Water-Air ( $T \approx 300 \text{ K}$ ):  $D_{AB} = 0.26 \times 10^{-4} \text{ m}^2/\text{s}$ .

**ANALYSIS:** (a) The evaporation rate from the towel is

$$n_A = \bar{h}_m A_s (\rho_{A,s} - \rho_{A,\infty})$$

where  $\bar{h}_m$  can be determined from the heat-mass transfer analogy, Eq. 6.60, with  $n = 1/3$ ,

$$\frac{h}{\bar{h}_m} = \rho c_p \text{Le}^{2/3} = \rho c_p \left( \frac{\alpha}{D_{AB}} \right)^{2/3} = 1.1614 \text{ kg/m}^3 \times 1007 \text{ J/kg} \cdot \text{K} \cdot \text{K} \left( \frac{22.5 \times 10^{-6}}{0.26 \times 10^{-4}} \right)^{2/3} = 1476 \text{ J/m}^3 \cdot \text{K}$$

$$\bar{h}_m = 28.7 \text{ W/m}^2 \cdot \text{K} / 1476 \text{ J/m}^3 \cdot \text{K} = 0.0194 \text{ m/s}$$

The evaporation rate is

$$n_A = 0.0194 \text{ m/s} \times (0.0925 \times 0.0925) \text{ m}^2 (0.0436 - 0) \text{ kg/m}^3 = 7.25 \times 10^{-6} \text{ kg/s} \quad <$$

(b) Performing an energy balance on the towel considering processes of evaporation, convection and radiation, find

$$\dot{E}_{\text{in}} - \dot{E}_{\text{out}} = q_{\text{conv}} - q_{\text{evap}} + q_{\text{rad}} = 0$$

$$\bar{h} A_s (T_{\infty} - T_s) - n_A h_{fg} + q_{\text{rad}} = 0$$

$$q_{\text{rad}} = 7.25 \times 10^{-6} \text{ kg/s} \times 2414 \times 10^3 \text{ J/kg} - 28.7 \text{ W/m}^2 (0.0925 \text{ m})^2 (290 - 310) \text{ K}$$

$$q_{\text{rad}} = 17.5 \text{ W} + 4.91 \text{ W} = 22.4 \text{ W} \quad <$$

Continued...

### PROBLEM 6.71 (Cont.)

The net radiation heat transfer to the towel is comprised of the absorbed irradiation and the net exchange between the surroundings and the towel,

$$q_{\text{rad}} = \alpha G A_s + \varepsilon A_s \sigma (T_{\text{sur}}^4 - T_s^4)$$

$$22.4 \text{ W} = 0.96 G (0.0925 \text{ m})^2 + 0.96 \times (0.0925 \text{ m})^2 5.67 \times 10^{-8} \text{ W/m}^2 \cdot \text{K}^4 (300^4 - 310^4) \text{ K}^4$$

Solving, find the irradiation from the lamps,

$$G = 2791 \text{ W/m}^2.$$

<

**COMMENTS:** (1) From the energy balance in Part (b), note that the heat rate by convection is considerably smaller than that by evaporation.

(2) As we'll learn in Chapter 12, the lamp irradiation found in Part (c) is approximately 2 times that of solar irradiation to the earth's surface.

## PROBLEM 6.72

**KNOWN:** Thin layer of water on concrete surface experiences evaporation, convection with ambient air, and radiation exchange with the sky. Average convection coefficient estimated as  $\bar{h} = 53 \text{ W/m}^2\cdot\text{K}$ .

**FIND:** (a) Heat fluxes associated with convection,  $q''_{\text{conv}}$ , evaporation,  $q''_{\text{evap}}$ , and radiation exchange with the sky,  $q''_{\text{rad}}$ , (b) Use results to explain why the concrete is wet instead of dry, and (c) Direction of heat flow and the heat flux by conduction into or out of the concrete.

**SCHEMATIC:**

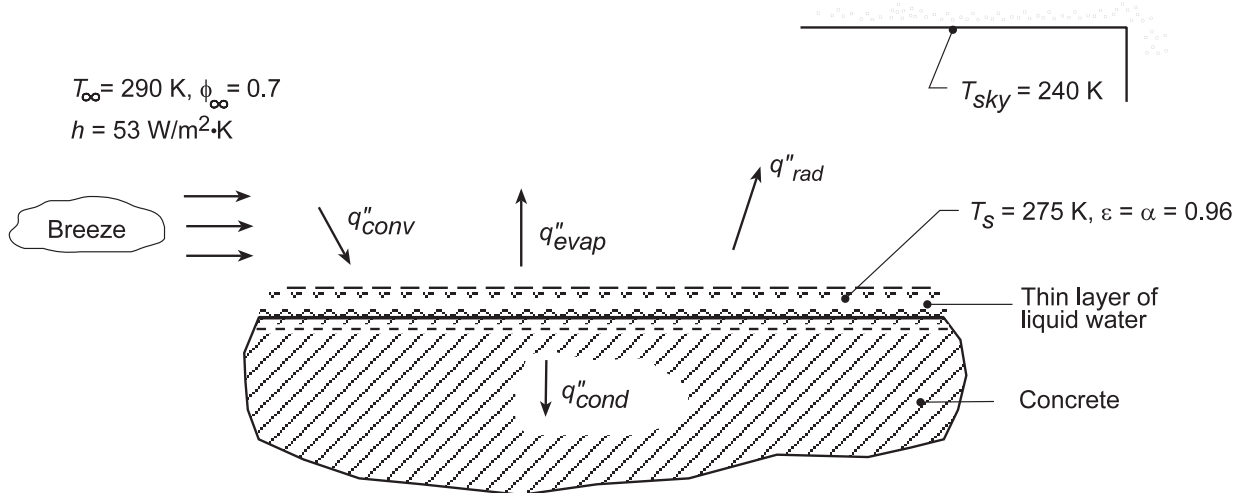

**ASSUMPTIONS:** (1) Steady-state conditions, (2) Vapor behaves as an ideal gas, (3) Constant properties, (4) Water surface is small compared to large, isothermal surroundings (sky), and (4) Applicability of the heat-mass transfer analogy.

**PROPERTIES:** Table A.4, Air ( $T_f = (T_{\infty} + T_s)/2 = 282.5 \text{ K}$ ):  $\rho = 1.243 \text{ kg/m}^3$ ,  $c_p = 1007 \text{ J/kg}\cdot\text{K}$ ,  $\alpha = 2.019 \times 10^5 \text{ m}^2/\text{s}$ ; Table A.8, Water-air ( $T_f = 282.5 \text{ K}$ ):  $D_{AB} = 0.26 \times 10^{-4} \text{ m}^2/\text{s} (282.5/298)^{3/2} = 0.24 \times 10^{-4} \text{ m}^2/\text{s}$ ; Table A.6, Water ( $T_s = 275 \text{ K}$ ):  $\rho_{A,s} = \rho_g = 1/v_g = 1/181.7 = 0.0055 \text{ kg/m}^3$ ,  $h_{fg} = 2497 \text{ kJ/kg}$ ; Table A.6, Water ( $T_{\infty} = 290 \text{ K}$ ):  $\rho_{A,\infty} = 1/69.7 = 0.0143 \text{ kg/m}^3$ .

**ANALYSIS:** (a) The heat fluxes associated with the processes shown on the schematic are

*Convection:*

$$q''_{\text{conv}} = \bar{h}(T_{\infty} - T_s) = 53 \text{ W/m}^2 \cdot \text{K} (290 - 275) \text{ K} = +795 \text{ W/m}^2 \quad <$$

*Radiation Exchange:*

$$q''_{\text{rad}} = \epsilon\sigma(T_s^4 - T_{\text{sky}}^4) = 0.96 \times 5.76 \times 10^{-8} \text{ W/m}^2 \cdot \text{K}^4 (275^4 - 240^4) \text{ K}^4 = +131 \text{ W/m}^2 \quad <$$

*Evaporation:*

$$q''_{\text{evap}} = n''_A h_{fg} = -2.255 \times 10^{-4} \text{ kg/s} \cdot \text{m}^2 \times 2497 \times 10^3 \text{ J/kg} = -563.1 \text{ W/m}^2 \quad <$$

where the evaporation rate from the surface is

$$n''_A = \bar{h}_m(\rho_{A,s} - \rho_{A,\infty}) = 0.050 \text{ m/s} (0.0055 - 0.7 \times 0.0143) \text{ kg/m}^3 = -2.255 \times 10^{-4} \text{ kg/s} \cdot \text{m}^2$$

Continued...



### PROBLEM 6.72 (Cont.)

and where the mass transfer coefficient is evaluated from the heat-mass transfer analogy, Eq. 6.60, with  $n = 1/3$ ,

$$\frac{\bar{h}}{\bar{h}_m} = \rho c_p Le^{2/3} = \rho c_p \left( \frac{\alpha}{D_{AB}} \right)^{2/3} = 1.243 \text{ kg/m}^3 \times 1007 \text{ J/kg} \cdot \text{K} \left( \frac{2.019 \times 10^{-5}}{0.26 \times 10^{-4}} \right)^{2/3}$$

$$\frac{\bar{h}}{\bar{h}_m} = 1058 \text{ J/m}^3 \cdot \text{K}$$

$$\bar{h}_m = 53 \text{ W/m}^2 \cdot \text{K} / 1058 \text{ J/m}^3 \cdot \text{K} = 0.050 \text{ m/s}$$

(b) From the foregoing evaporation calculations, note that water vapor from the air is condensing on the liquid water layer. That is, vapor is being transported to the surface, explaining why the concrete surface is wet, even without rain.

(c) From an overall energy balance on the water film considering conduction in the concrete as shown in the schematic,

$$\dot{E}_{\text{in}} - \dot{E}_{\text{out}} = 0$$

$$q''_{\text{conv}} - q''_{\text{evap}} - q''_{\text{rad}} - q''_{\text{cond}} = 0$$

$$q''_{\text{cond}} = q''_{\text{conv}} - q''_{\text{evap}} - q''_{\text{rad}}$$

$$q''_{\text{cond}} = 1795 \text{ W/m}^2 - (-563.1 \text{ W/m}^2) - (+131 \text{ W/m}^2) = 1227 \text{ W/m}^2 \quad <$$

The heat flux by conduction is *into* the concrete.

### PROBLEM 6.73

**KNOWN:** Heater power required to maintain wetted (water) plate at 27°C, and average convection coefficient for specified dry air temperature, case (a).

**FIND:** Heater power required to maintain the plate at 37°C for the same dry air temperature if the convection coefficients remain unchanged, case (b).

**SCHEMATIC:**

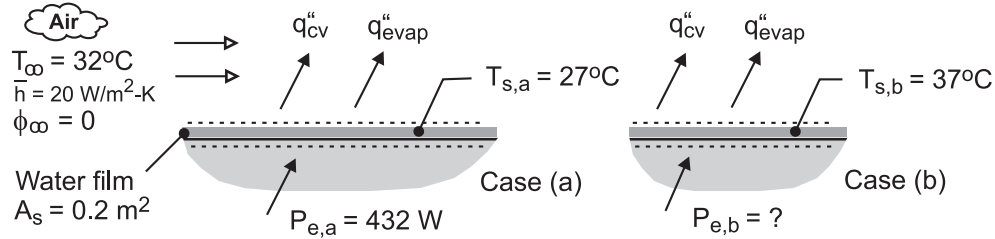

**ASSUMPTIONS:** (1) Steady-state conditions, (2) Convection coefficients unchanged for different plate temperatures, (3) Air stream is dry at atmospheric pressure, and (4) Negligible heat transfer from the bottom side of the plate.

**PROPERTIES:** Table A-6, Water ( $T_{s,a} = 27^\circ\text{C} = 300\text{ K}$ ):  $\rho_{A,s} = 1/v_g = 0.02556\text{ kg/m}^3$ ,  $h_{fg} = 2.438 \times 10^6\text{ J/kg}$ ; Water ( $T_{s,b} = 37^\circ\text{C} = 310\text{ K}$ ):  $\rho_{A,s} = 1/v_g = 0.04361\text{ kg/m}^3$ ,  $h_{fg} = 2.414 \times 10^6\text{ J/kg}$ .

**ANALYSIS:** For case (a) with  $T_s = 27^\circ\text{C}$  and  $P_e = 432\text{ W}$ , perform an energy balance on the plate to determine the mass transfer coefficient  $h_m$ .

$$\dot{E}_{in} - \dot{E}_{out} = 0$$

$$P_{e,a} - (q''_{evap} + q''_{cv})A_s = 0$$

Substituting the rate equations and appropriate properties,

$$P_{e,a} - \left[ \bar{h}_m (\rho_{A,s} - \rho_{A,\infty}) h_{fg} + \bar{h} (T_{s,a} - T_\infty) \right] A_s = 0$$

$$432\text{ W} - \left[ \bar{h}_m (0.02556\text{ kg/m}^3 - 0) \times 2.438 \times 10^6\text{ J/kg} + 20\text{ W/m}^2 \cdot \text{K} (27 - 32)\text{ K} \right] \times 0.2\text{ m}^2 = 0$$

where  $\rho_{A,s}$  and  $h_{fg}$  are evaluated at  $T_s = 27^\circ\text{C} = 300\text{ K}$ . Find,

$$\bar{h}_m = 0.0363\text{ m/s}$$

For case (b), with  $T_s = 37^\circ\text{C}$  and the same values for  $\bar{h}$  and  $\bar{h}_m$ , perform an energy balance to determine the heater power required to maintain this condition.

$$P_{e,b} - \left[ \bar{h}_m (\rho_{A,s} - 0) h_{fg} + \bar{h} (T_{s,b} - T_\infty) \right] A_s = 0$$

$$P_{e,b} - \left[ 0.0363\text{ m/s} (0.04361 - 0)\text{ kg/m}^3 \times 2.414 \times 10^6\text{ J/kg} + 20\text{ W/m}^2 \cdot \text{K} (37 - 32)\text{ K} \right] \times 0.2\text{ m}^2 = 0$$

$$P_{e,b} = 784\text{ W}$$

where  $\rho_{A,a}$  and  $h_{fg}$  are evaluated at  $T_s = 37^\circ\text{C} = 310\text{ K}$ .

<

## PROBLEM 6.74

**KNOWN:** Dry air at 32°C flows over a wetted plate of width 1 m maintained at a surface temperature of 27°C by an embedded heater supplying 432 W.

**FIND:** (a) The evaporation rate of water from the plate,  $n_A$  (kg/h) and (b) The plate temperature  $T_s$  when all the water is evaporated, but the heater power remains the same.

**SCHEMATIC:**

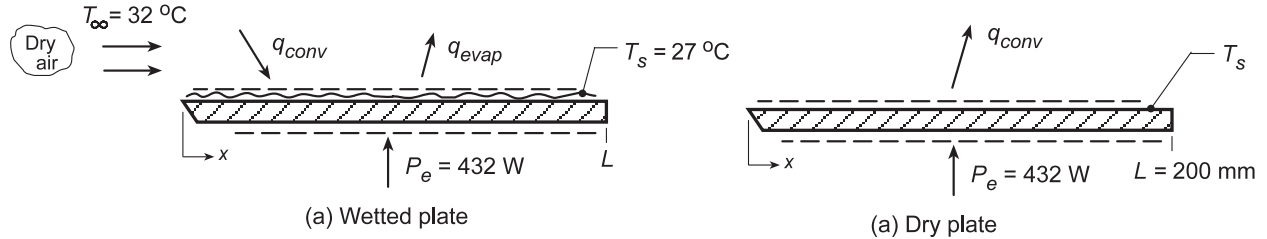

**ASSUMPTIONS:** (1) Steady-state conditions, (2) Vapor behaves as an ideal gas, (3) Constant properties, and (4) Applicability of the heat-mass transfer analogy.

**PROPERTIES:** Table A.4, Air ( $T_f = (32 + 27)^\circ\text{C}/2 = 302.5$  K):  $\rho = 1.153$  kg/m<sup>3</sup>,  $c_p = 1007$  J/kg·K,  $\alpha = 2.287 \times 10^{-5}$  m<sup>2</sup>/s; Table A.8, Water-air ( $T_f \approx 300$  K):  $D_{AB} = 0.26 \times 10^{-4}$  m<sup>2</sup>/s; Table A.6, Water ( $T_s = 27^\circ\text{C} = 300$  K):  $\rho_{A,s} = 1/v_g = 1/39.13 = 0.0256$  kg/m<sup>3</sup>,  $h_{fg} = 2438$  kJ/kg.

**ANALYSIS:** (a) Perform an energy balance on the wetted plate to obtain the evaporation rate,  $n_A$ .

$$\begin{aligned} \dot{E}_{\text{in}} - \dot{E}_{\text{out}} &= 0 & P_e + q_{\text{conv}} - q_{\text{evap}} &= 0 \\ P_e + \bar{h}A_s(T_\infty - T_s) - n_A h_{fg} &= 0 \end{aligned} \quad (1)$$

In order to find  $\bar{h}$ , invoke the heat-mass transfer analogy, Eq. (6.60) with  $n = 1/3$ ,

$$\frac{\bar{h}}{\bar{h}_m} = \rho c_p L e^{2/3} = \rho c_p \left( \frac{\alpha}{D_{AB}} \right)^{2/3} = 1.153 \text{ kg/m}^3 \times 1007 \text{ J/kg} \cdot \text{K} \left( \frac{2.287 \times 10^{-5}}{0.26 \times 10^{-4}} \right)^{2/3} = 1066 \text{ J/m}^3 \cdot \text{K} \quad (2)$$

The evaporation rate equation

$$n_A = \bar{h}_m A_s (\rho_{A,s} - \rho_{A,\infty})$$

Substituting Eqs. (2) and (3) into Eq. (1), find  $\bar{h}_m$

$$\begin{aligned} P_e + (1066 \text{ J/m}^3 \cdot \text{K} \bar{h}_m) A_s (T_\infty - T_s) - \bar{h}_m A_s (\rho_{A,s} - \rho_{A,\infty}) h_{fg} &= 0 \quad (4) \\ 432 \text{ W} + [1066 \text{ J/m}^3 \cdot \text{K} (32 - 27) \text{ K} - (0.0256 - 0) \text{ kg/m}^3 \times 2438 \times 10^3 \text{ J/kg}] (0.200 \times 1) \text{ m}^2 \cdot \bar{h}_m &= 0 \\ 432 + [5330 - 62,413] \times 0.20 \bar{h}_m &= 0 \\ \bar{h}_m &= 0.0378 \text{ m/s} \end{aligned}$$

Using Eq. (3), find

$$n_A = 0.0378 \text{ m/s} (0.200 \times 1) \text{ m}^2 (0.0256 - 0) \text{ kg/m}^3 = 1.94 \times 10^{-4} \text{ kg/s} = 0.70 \text{ kg/h} \quad <$$

(b) When the plate is dry, all the power must be removed by convection,

$$P_e = q_{\text{conv}} = \bar{h} A_s (T_s - T_\infty)$$

Assuming  $\bar{h}$  is the same as for conditions with the wetted plate,

$$T_s = T_\infty + P_e / (\bar{h} A_s) = T_\infty + P_e / (1066 \bar{h}_m) A_s$$

$$T_s = 32^\circ\text{C} + 432 \text{ W} / (1066 \times 0.0378 \text{ W/m}^2 \cdot \text{K} \times 0.200 \text{ m}^2) = 85.6^\circ\text{C} \quad <$$

### PROBLEM 6.75

**KNOWN:** Surface temperature of a 20-mm diameter sphere is 32°C when dissipating 2.51 W in a dry air stream at 22°C.

**FIND:** Power required by the imbedded heater to maintain the sphere at 32°C if its outer surface has a thin porous covering saturated with water for the same dry air temperature.

**SCHEMATIC:**

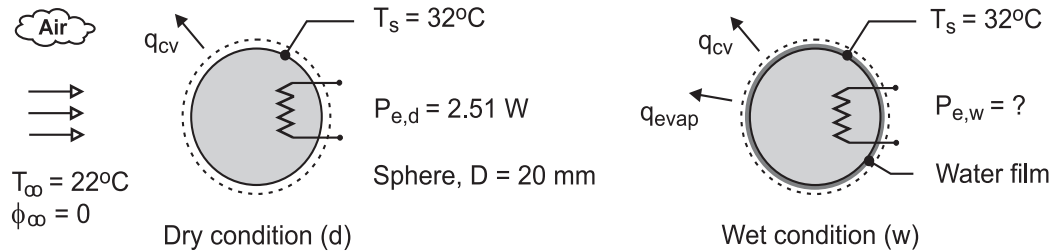

**ASSUMPTIONS:** (1) Steady-state conditions, (2) Heat and mass transfer analogy is applicable, (3) Heat transfer convection coefficient is the same for the dry and wet condition, and (3) Properties of air and the diffusion coefficient of the air-water vapor mixture evaluated at 300 K.

**PROPERTIES:** Table A-4, Air (300 K, 1 atm):  $\rho = 1.1614 \text{ kg/m}^3$ ,  $c_p = 1007 \text{ J/kg}\cdot\text{K}$ ,  $\alpha = 22.5 \times 10^{-6} \text{ m}^2/\text{s}$ ; Table A-8, Water-air mixture (300 K, 1 atm):  $D_{A-B} = 0.26 \times 10^{-4} \text{ m}^2/\text{s}$ ; Table A-4, Water (305 K, 1 atm):  $\rho_{A,s} = 1/v_g = 0.03362 \text{ kg/m}^3$ ,  $h_{fg} = 2.426 \times 10^6 \text{ J/kg}$ .

**ANALYSIS:** For the *dry case* (d), perform an energy balance on the sphere and calculate the heat transfer convection coefficient.

$$\dot{E}_{\text{in}} - \dot{E}_{\text{out}} = P_{e,d} - q_{cv} = 0 \quad P_{e,d} - \bar{h} A_s (T_s - T_\infty) = 0$$

$$2.51 \text{ W} - \bar{h} \pi (0.020 \text{ m})^2 \times (32 - 22) \text{ K} = 0 \quad \bar{h} = 200 \text{ W/m}^2 \cdot \text{K}$$

Use the heat-mass analogy, Eq. (6.60) with  $n = 1/3$ , to determine  $\bar{h}_m$ .

$$\frac{\bar{h}}{\bar{h}_m} = \rho c_p \left( \frac{\alpha}{D_{AB}} \right)^{2/3}$$

$$\frac{200 \text{ W/m}^2 \cdot \text{K}}{\bar{h}_m} = 1.1614 \text{ kg/m}^3 \times 1007 \text{ J/kg} \cdot \text{K} \left( \frac{22.5 \times 10^{-6} \text{ m}^2/\text{s}}{0.26 \times 10^{-4} \text{ m}^2/\text{s}} \right)^{2/3}$$

$$\bar{h}_m = 0.188 \text{ m/s}$$

For the *wet case* (w), perform an energy balance on the wetted sphere using values for  $\bar{h}$  and  $\bar{h}_m$  to determine the power required to maintain the same surface temperature.

$$\dot{E}_{\text{in}} - \dot{E}_{\text{out}} = P_{e,w} - q_{cv} - q_{\text{evap}} = 0$$

$$P_{e,w} - \left[ \bar{h} (T_s - T_\infty) + \bar{h}_m (\rho_{A,s} - \rho_{A,\infty}) h_{fg} \right] A_s = 0$$

$$P_{e,w} - \left[ 200 \text{ W/m}^2 \cdot \text{K} (32 - 22) \text{ K} + \right.$$

$$\left. 0.188 \text{ m/s} (0.03362 - 0) \text{ kg/m}^3 \times 2.426 \times 10^6 \text{ J/kg} \right] \pi (0.020 \text{ m})^2 = 0$$

$$P_{e,w} = 21.8 \text{ W}$$

<

**COMMENTS:** Note that  $\rho_{A,s}$  and  $h_{fg}$  for the mass transfer rate equation are evaluated at  $T_s = 32^\circ\text{C} = 305 \text{ K}$ , not 300 K. The effect of evaporation is to require nearly 8.5 times more power to maintain the same surface temperature.

### PROBLEM 6.76

**KNOWN:** Operating temperature, ambient air conditions and make-up water requirements for a hot tub.

**FIND:** Heater power required to maintain prescribed conditions.

**SCHEMATIC:**

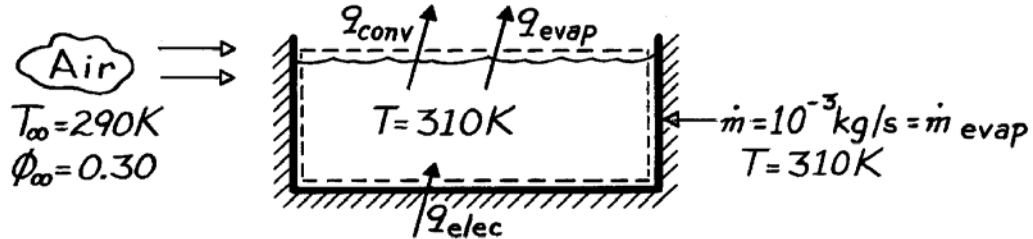

**ASSUMPTIONS:** (1) Side wall and bottom are adiabatic, (2) Heat and mass transfer analogy is applicable.

**PROPERTIES:** Table A-4, Air ( $\bar{T} = 300\text{K}$ , 1 atm):  $\rho = 1.161\text{ kg/m}^3$ ,  $c_p = 1007\text{ J/kg}\cdot\text{K}$ ,  $\alpha = 22.5 \times 10^{-6}\text{ m}^2/\text{s}$ ; Table A-6, Sat. water vapor ( $T = 310\text{K}$ ):  $h_{fg} = 2414\text{ kJ/kg}$ ,  $\rho_{A,sat}(T) = 1/v_g = (22.93\text{ m}^3/\text{kg})^{-1} = 0.0436\text{ kg/m}^3$ ; ( $T_\infty = 290\text{K}$ ):  $\rho_{A,sat}(T_\infty) = 1/v_g = (69.7\text{ m}^3/\text{kg})^{-1} = 0.0143\text{ kg/m}^3$ ; Table A-8, Air-water vapor (298K):  $D_{AB} = 26 \times 10^{-6}\text{ m}^2/\text{s}$ .

**ANALYSIS:** Applying an energy balance to the control volume,

$$q_{elec} = q_{conv} + q_{evap} = \bar{h} A (T - T_\infty) + \dot{m}_{evap} h_{fg}(T).$$

Obtain  $\bar{h} A$  from Eq. 6.60 with  $n = 1/3$ ,

$$\frac{\bar{h}}{h_m} = \frac{\bar{h}_A}{h_{m,A}} = \rho c_p Le^{2/3}$$

$$\bar{h} A = \bar{h}_m A \rho c_p Le^{2/3} = \frac{\dot{m}_{evap}}{\rho_{A,sat}(T) - \phi_\infty \rho_{A,sat}(T_\infty)} \rho c_p Le^{2/3}.$$

Substituting numerical values,

$$Le = \alpha/D_{AB} = (22.5 \times 10^{-6}\text{ m}^2/\text{s}) / 26 \times 10^{-6}\text{ m}^2/\text{s} = 0.865$$

$$\bar{h}_m A = \frac{10^{-3}\text{ kg/s}}{[0.0436 - 0.3 \times 0.0143]\text{ kg/m}^3} \cdot 1.161 \frac{\text{kg}}{\text{m}^3} \times 1007 \frac{\text{J}}{\text{kg}\cdot\text{K}} (0.865)^{2/3}$$

$$\bar{h}_m A = 27.0\text{ W/K}.$$

Hence, the required heater power is

$$q_{elec} = 27.0\text{ W/K} (310 - 290)\text{ K} + 10^{-3}\text{ kg/s} \times 2414\text{ kJ/kg} \times 1000\text{ J/kJ}$$

$$q_{elec} = (540 + 2414)\text{ W} = 2954\text{ W}.$$

**COMMENTS:** The evaporative heat loss is dominant.

<

### PROBLEM 6.77

**KNOWN:** Water freezing under conditions for which the air temperature exceeds 0°C.

**FIND:** (a) Lowest air temperature,  $T_\infty$ , before freezing occurs, neglecting evaporation, (b) The mass transfer coefficient,  $h_m$ , for the evaporation process, (c) Lowest air temperature,  $T_\infty$ , before freezing occurs, including evaporation.

**SCHEMATIC:**

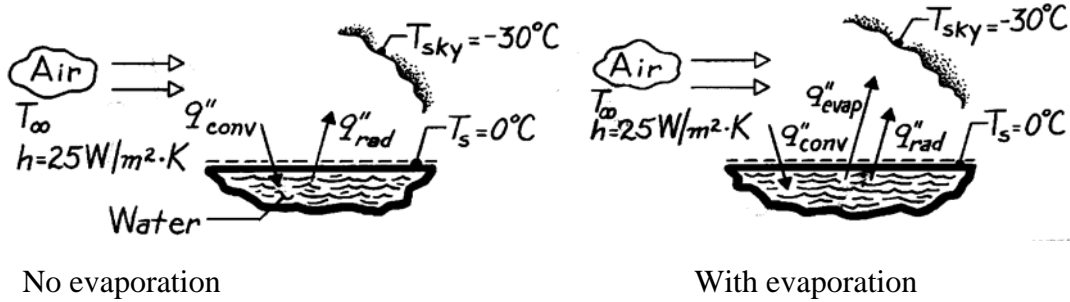

**ASSUMPTIONS:** (1) Steady-state conditions, (2) Water insulated from ground, (3) Water surface has  $\epsilon = 1$ , (4) Heat-mass transfer analogy applies, (5) Ambient air is dry.

**PROPERTIES:** Table A-4, Air ( $T_f \approx 2.5^\circ\text{C} \approx 276\text{K}$ , 1 atm):  $\rho = 1.2734 \text{ kg/m}^3$ ,  $c_p = 1006 \text{ J/kg}\cdot\text{K}$ ,  $\alpha = 19.3 \times 10^{-6} \text{ m}^2/\text{s}$ ; Table A-6, Water vapor (273.15K):  $h_{fg} = 2502 \text{ kJ/kg}$ ,  $\rho_g = 1/v_g = 4.847 \times 10^{-3} \text{ kg/m}^3$ ; Table A-8, Water vapor - air (298K):  $D_{AB} = 0.26 \times 10^{-4} \text{ m}^2/\text{s}$ .

**ANALYSIS:** (a) Neglecting evaporation and performing an energy balance,

$$q''_{\text{conv}} - q''_{\text{rad}} = 0$$

$$h(T_\infty - T_s) - \epsilon\sigma(T_s^4 - T_{\text{sky}}^4) = 0 \quad \text{or} \quad T_\infty = T_s + (\epsilon\sigma/h)(T_s^4 - T_{\text{sky}}^4)$$

$$T_\infty = 0^\circ\text{C} + \frac{1 \times 5.667 \times 10^{-8} \text{ W/m}^2 \cdot \text{K}^4}{25 \text{ W/m}^2 \cdot \text{K}} \left[ (0 + 273)^4 - (-30 + 273)^4 \right] = 4.69^\circ\text{C}. \quad <$$

(b) Invoking the heat-mass transfer analogy in the form of Eq. 6.60 with  $n = 1/3$ ,

$$\frac{h}{h_m} = \rho c_p \text{Le}^{2/3} \quad \text{or} \quad h_m = h/\rho c_p \text{Le}^{2/3} \quad \text{where} \quad \text{Le} = \alpha/D_{AB}$$

$$h_m = (25 \text{ W/m}^2 \cdot \text{K}) / 1.273 \text{ kg/m}^3 (1006 \text{ J/kg} \cdot \text{K}) \left[ \frac{19.3 \times 10^{-6} \text{ m}^2/\text{s}}{0.26 \times 10^{-4} \text{ m}^2/\text{s}} \right]^{2/3} = 0.0238 \text{ m/s}. \quad <$$

(c) Including evaporation effects and performing an energy balance gives  $q''_{\text{conv}} - q''_{\text{rad}} - q''_{\text{evap}} = 0$

where  $q''_{\text{evap}} = \dot{m}'' h_{fg} = h_m(\rho_{A,s} - \rho_{A,\infty})h_{fg}$ ,  $\rho_{A,s} = \rho_g$  and  $\rho_{A,\infty} = 0$ . Hence,

$$T_\infty = T_s + (\epsilon\sigma/h)(T_s^4 - T_{\text{sky}}^4) + (h_m/h)(\rho_g - 0)h_{fg}$$

$$T_\infty = 4.69^\circ\text{C} + \frac{0.0238 \text{ m/s}}{25 \text{ W/m}^2 \cdot \text{K}} \times 4.847 \times 10^{-3} \text{ kg/m}^3 \times 2.502 \times 10^6 \text{ J/kg}$$

$$T_\infty = 4.69^\circ\text{C} + 11.5^\circ\text{C} = 16.2^\circ\text{C}. \quad <$$

### PROBLEM 6.78

**KNOWN:** Wet-bulb and dry-bulb temperature for water vapor-air mixture.

**FIND:** (a) Partial pressure,  $p_A$ , and relative humidity,  $\phi$ , using Carrier's equation, (b)  $p_A$  and  $\phi$  using psychrometric chart, (c) Difference between air stream,  $T_\infty$ , and wet bulb temperatures based upon evaporative cooling considerations.

**SCHEMATIC:**

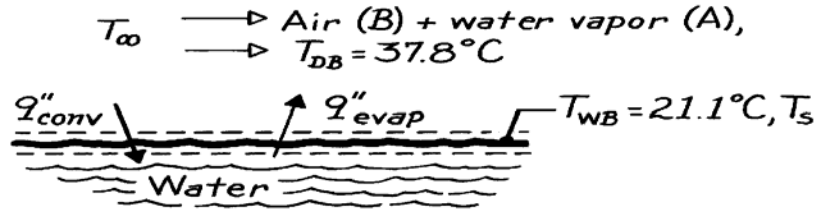

**ASSUMPTIONS:** (1) Evaporative cooling occurs at interface, (2) Heat-mass transfer analogy applies, (3) Species A and B are perfect gases.

**PROPERTIES:** Table A-6, Water vapor:  $p_{A,\text{sat}}(21.1^\circ\text{C}) = 0.02512 \text{ bar}$ ,  $p_{A,\text{sat}}(37.8^\circ\text{C}) = 0.06603 \text{ bar}$ ,  $h_{fg}(21.1^\circ\text{C}) = 2451 \text{ kJ/kg}$ ; Table A-4, Air ( $T_{\text{am}} = [T_{\text{WB}} + T_{\text{DB}}]/2 \cong 300\text{K}$ , 1 atm):  $\alpha = 22.5 \times 10^{-6} \text{ m}^2/\text{s}$ ,  $c_p = 1007 \text{ J/kg}\cdot\text{K}$ ,  $\rho = 1.15 \text{ kg/m}^3$ ; Table A-8, Air-water vapor (298K):  $D_{AB} = 0.26 \times 10^{-4} \text{ m}^2/\text{s}$ .

**ANALYSIS:** (a) Carrier's equation has the form

$$p_v = p_{\text{gw}} - \frac{(p - p_{\text{gw}})(T_{\text{DB}} - T_{\text{WB}})}{1810 - T_{\text{WB}}}$$

where  $p_v$  = partial pressure of vapor in air stream, bar

$p_{\text{gw}}$  = sat. pressure at  $T_{\text{WB}} = 21.1^\circ\text{C}$ , 0.02512 bar

$p$  = total pressure of mixture, 1.033 bar

$T_{\text{DB}}$  = dry bulb temperature,  $37.8^\circ\text{C}$

$T_{\text{WB}}$  = wet bulb temperature,  $21.1^\circ\text{C}$ .

Hence,

$$p_v = 0.02512 \text{ bar} - \frac{(1.033 - 0.02512) \text{ bar} \times (37.8 - 21.1)^\circ\text{C}}{1810 - (21.1 + 273.1) \text{ K}} = 0.0142 \text{ bar.}$$

The relative humidity,  $\phi$ , is then

$$\phi \equiv \frac{p_A}{p_{A,\text{sat}}} = \frac{p_v}{p_A(37.8^\circ\text{C})} = \frac{0.0142 \text{ bar}}{0.06603 \text{ bar}} = 0.214. \quad <$$

(b) Using a psychrometric chart

$$\left. \begin{array}{l} T_{\text{WB}} = 21.1^\circ\text{C} = 70^\circ\text{F} \\ T_{\text{DB}} = 37.8^\circ\text{C} = 100^\circ\text{F} \end{array} \right\} \phi \approx 0.225 \quad <$$

$$p_v = \phi p_{\text{sat}} = 0.225 \times 0.06603 \text{ bar} = 0.0149 \text{ bar.} \quad <$$

Continued ...

**PROBLEM 6.78 (Cont.)**

(c) An application of the heat-mass transfer analogy is the process of evaporative cooling which occurs when air flows over water. The change in temperature is estimated by Eq. 6.65.

$$T_{\infty} - T_s = \frac{\mathcal{M}_A h_{fg}}{\mathcal{R} \rho c_p L e^{2/3}} \left[ \frac{p_{A,sat}(T_s)}{T_s} - \frac{p_{A,\infty}}{T_{\infty}} \right]$$

or

$$(37.8 - 21.1)\text{K} = \frac{(18\text{kg/kmol} \times 2451 \times 10^3 \text{J/kg})}{8.314 \times 10^{-2} \text{m}^3 \text{bar/kmol} \cdot \text{K} \times 1.16 \text{kg/m}^3 \times 1007 \text{J/kg} \cdot \text{K} \times \left( \frac{22.5 \times 10^{-6} \text{m}^2/\text{s}}{0.26 \times 10^{-4} \text{m}^2/\text{s}} \right)^{2/3}} \times \left[ \frac{0.02512 \text{bar}}{(273 + 21.1)\text{K}} + \frac{p_{A,\infty}}{(273 + 37.8)\text{K}} \right]$$

Thus,  $p_{A,\infty} = 0.016 \text{ bar}$

and

$$\phi = p_A/p_{A,sat} = p_v/p_{A,sat} = 0.016 \text{ bar}/0.06603 \text{ bar} = 0.242 \quad <$$

**COMMENTS:** The following table compares results from the two calculation methods.

	<i>Carrier's Eq.</i>	<i>Psychrometric Chart</i>
$p_v$ (bar)	0.0142	0.016
$\phi$	0.214	0.242

$$\% \text{ Difference: } \frac{0.242 - 0.214}{0.214} \times 100 = 13.1\%$$



## PROBLEM 6.79

**KNOWN:** Initial temperature and droplet diameter of water mist. Expression for Nusselt number. Temperature and relative humidity of air stream.

**FIND:** (a) Initial convection heat transfer rate, evaporative heat loss rate, and rate of change of droplet temperature, (b) Steady-state droplet temperature.

**SCHEMATIC:**

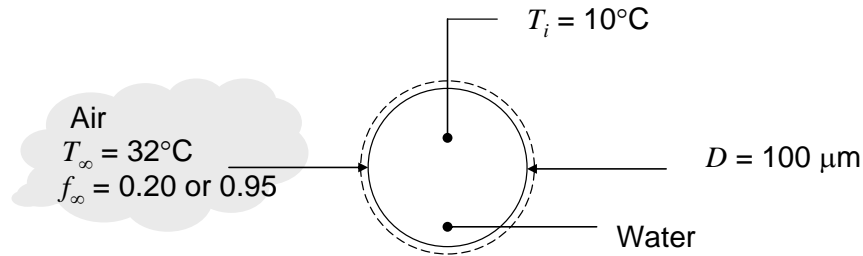

**ASSUMPTIONS:** (1) The properties of the air-water vapor mixture can be approximated by pure air properties, (2) Air properties and  $D_{AB}$  evaluated at  $T_{am} = (T_s + T_\infty)/2$ .

**PROPERTIES:** Table A-4, Air ( $T = 294$  K):  $k = 0.0258$  W/m·K; Table A-8, H<sub>2</sub>O in Air ( $T = 294$  K):  $D_{AB} = 0.26 \times 10^{-4}$  m<sup>2</sup>/s  $(294/298)^{3/2} = 0.255 \times 10^{-4}$  m<sup>2</sup>/s; Table A-6, Water ( $T = 283$  K):  $\rho_{A,sat}(T_s) = 1/111.8$  m<sup>3</sup>/kg = 0.00894 kg/m<sup>3</sup>,  $h_{fg} = 2478$  kJ/kg,  $\rho_w = 1000$  kg/m<sup>3</sup>,  $c_{p,w} = 4193$  J/kg·K; ( $T = 305$  K):  $\rho_{A,sat}(T_\infty) = 1/29.74$  m<sup>3</sup>/kg = 0.0336 kg/m<sup>3</sup>.

**ANALYSIS:** (a) The convection heat transfer coefficient is

$$\bar{h} = \overline{Nu}_{Dk} / D = 2k / D = 2 \times 0.0258 \text{ W/m} \cdot \text{K} / 100 \times 10^{-6} \text{ m} = 516 \text{ W/m}^2 \cdot \text{K}$$

At the initial time, when the droplet temperature is  $T_i = 10^\circ\text{C}$ , the convection heat transfer rate to the droplet is given by

$$q_{\text{conv}} = \bar{h}A_s(T_\infty - T_i) = 516 \text{ W/m}^2 \cdot \text{K} \times \pi(100 \times 10^{-6} \text{ m})^2 \times (32 - 10)^\circ\text{C} = 357 \times 10^{-6} \text{ W} \quad <$$

Referring to Eq. 6.59, since  $Nu$  is independent of  $Pr$ ,  $n = 0$ , and we have

$$Nu = Sh = 2 \quad \text{or} \quad \bar{h}_m = 2D_{AB} / D = 2 \times 0.255 \times 10^{-4} \text{ m}^2/\text{s} / 100 \times 10^{-6} \text{ m} = 0.510 \text{ m/s}$$

Thus the rate of evaporative heat loss can be expressed as

$$q_{\text{evap}} = \dot{m}_{\text{evap}} h_{fg} = \bar{h}_m A_s (\rho_{A,s} - \rho_{A,\infty}) h_{fg}$$

For  $\phi_\infty = 0.20$ ,  $\rho_{A,\infty} = \phi_\infty \rho_{A,sat}(T_\infty) = 0.2 \times 0.0336 \text{ kg/m}^3 = 0.00672 \text{ kg/m}^3$ . Thus,

$$\begin{aligned} q_{\text{evap}} &= \dot{m}_{\text{evap}} h_{fg} = \bar{h}_m A_s (\rho_{A,s} - \rho_{A,\infty}) h_{fg} \\ &= 0.510 \text{ m/s} \times \pi(100 \times 10^{-6} \text{ m})^2 \times (0.00894 - 0.00672) \text{ kg/m}^3 \times 2478 \times 10^3 \text{ J/kg} \\ &= 88.1 \times 10^{-6} \text{ W} \end{aligned} \quad <$$

Continued...

### PROBLEM 6.79 (Cont.)

Similarly, for  $\phi_\infty = 0.95$ ,  $\rho_{A,\infty} = \phi_\infty \rho_{A,\text{sat}}(T_\infty) = 0.95 \times 0.0336 \text{ kg/m}^3 = 0.0319 \text{ kg/m}^3$

$$q_{\text{evap}} = -912 \times 10^{-6} \text{ W} \quad <$$

The rate of change of temperature of the droplet can be found from an energy balance on the droplet:

$$(\rho c_p V)_w \frac{dT}{dt} = q_{\text{conv}} - q_{\text{evap}}$$

For  $\phi_\infty = 0.20$ ,

$$\frac{dT}{dt} = \frac{q_{\text{conv}} - q_{\text{evap}}}{(\rho c_p V)_w} = \frac{(357 - 88.1) \times 10^{-6} \text{ W}}{1000 \text{ kg/m}^3 \times 4193 \text{ J/kg} \cdot \text{K} \times \pi \times (100 \times 10^{-6} \text{ m})^3 / 6} = 122 \text{ K/s} <$$

And for  $\phi_\infty = 0.95$ ,

$$\frac{dT}{dt} = \frac{q_{\text{conv}} - q_{\text{evap}}}{(\rho c_p V)_w} = \frac{(357 + 912) \times 10^{-6} \text{ W}}{1000 \text{ kg/m}^3 \times 4193 \text{ J/kg} \cdot \text{K} \times \pi \times (100 \times 10^{-6} \text{ m})^3 / 6} = 578 \text{ K/s} <$$

For  $\phi_\infty = 0.20$ , the evaporative heat loss is positive; the droplet is evaporating. Convection from the warm air is warming the droplet, while evaporation is cooling it. The net effect is to warm the droplet. For  $\phi_\infty = 0.95$ , the evaporative heat loss is negative; water from the humid environment is condensing on the droplet. Both convection and condensation cause warming of the droplet, so the rate of temperature increase is higher in this case. Eventually, the droplet will become warm enough so that condensation ceases and evaporation will begin. <

(b) At steady-state, an energy balance requires  $q_{\text{conv}} = q_{\text{evap}}$ . Eq. 6.64 applies, with  $\bar{h}_m / \bar{h} = D_{AB} / k$ . Thus, the following implicit equation must be solved for  $T_s$ :

$$T_\infty - T_s = h_{fg} \frac{D_{AB}}{k} [\rho_{A,\text{sat}}(T_s) - \rho_{A,\infty}]$$

where the properties  $D_{AB}$  and  $k$  should be evaluated at  $T_{\text{am}} = (T_s + T_\infty)/2$ , and  $h_{fg}$  should be evaluated at  $T_s$ . This equation is most easily solved in IHT, which yields

$$T_s = 289 \text{ K for } \phi_\infty = 0.20 \quad <$$

$$T_s = 304 \text{ K for } \phi_\infty = 0.95 \quad <$$

**COMMENTS:** (1) As expected, the steady-state droplet temperature is lower for the low humidity conditions. (2) The steady-state temperature does not depend on the droplet diameter because the areas for convection and evaporation are the same and the heat and mass transfer coefficients have the same dependence on diameter. (3) Based on the initial rate of temperature increase, it appears that the droplet will take less than 1 s to reach its steady-state temperature. A complete analysis of the transient problem shows that the steady-state temperature is reached in approximately 0.17 and 0.15 s for the  $\phi_\infty = 0.20$  and 0.95 cases, respectively. In this time period, the change in diameter of the droplet is less than 1% in both cases. Of course, the droplet will eventually evaporate.

## PROBLEM 6.80

**KNOWN:** Wet and dry bulb temperatures.

**FIND:** Relative humidity of air.

**SCHEMATIC:**

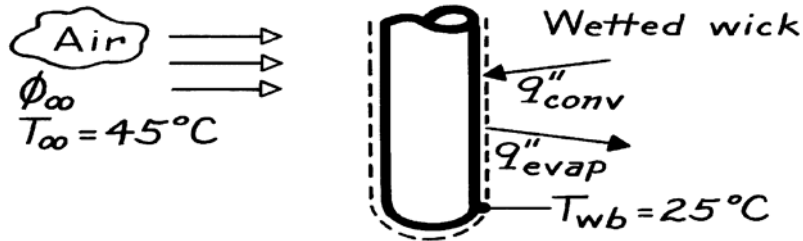

**ASSUMPTIONS:** (1) Perfect gas behavior for vapor, (2) Steady-state conditions, (3) Negligible radiation, (4) Negligible conduction along thermometer.

**PROPERTIES:** Table A-4, Air (308K, 1 atm):  $\rho = 1.135 \text{ kg/m}^3$ ,  $c_p = 1007 \text{ J/kg}\cdot\text{K}$ ,  $\alpha = 23.7 \times 10^{-6} \text{ m}^2/\text{s}$ ; Table A-6, Saturated water vapor (298K):  $v_g = 44.25 \text{ m}^3/\text{kg}$ ,  $h_{fg} = 2443 \text{ kJ/kg}$ ; (318K):  $v_g = 15.52 \text{ m}^3/\text{kg}$ ; Table A-8, Air-vapor (1 atm, 298K):  $D_{AB} = 0.26 \times 10^{-4} \text{ m}^2/\text{s}$ ,  $D_{AB}$  (308K) =  $0.26 \times 10^{-4} \text{ m}^2/\text{s} \times (308/298)^{3/2} = 0.27 \times 10^{-4} \text{ m}^2/\text{s}$ ,  $Le = \alpha/D_{AB} = 0.88$ .

**ANALYSIS:** From an energy balance on the wick, Eq. 6.64 follows from Eq. 6.61. Dividing Eq. 6.64 by  $\rho_{A,\text{sat}}(T_\infty)$ ,

$$\frac{T_\infty - T_s}{\rho_{A,\text{sat}}(T_\infty)} = h_{fg} \left[ \frac{h_m}{h} \right] \left[ \frac{\rho_{A,\text{sat}}(T_s)}{\rho_{A,\text{sat}}(T_\infty)} - \frac{\rho_{A,\infty}}{\rho_{A,\text{sat}}(T_\infty)} \right].$$

With  $[\rho_{A,\infty} / \rho_{A,\text{sat}}(T_\infty)] \approx \phi_\infty$  for a perfect gas and  $h/h_m$  given by Eq. 6.60,

$$\phi_\infty = \frac{\rho_{A,\text{sat}}(T_s)}{\rho_{A,\text{sat}}(T_\infty)} - \frac{\rho c_p Le^{2/3}}{\rho_{A,\text{sat}}(T_\infty) h_{fg}} (T_\infty - T_s).$$

Using the property values, evaluate

$$\frac{\rho_{A,\text{sat}}(T_s)}{\rho_{A,\text{sat}}(T_\infty)} = \frac{v_g(T_\infty)}{v_g(T_s)} = \frac{15.52}{44.25} = 0.351$$

$$\rho_{A,\text{sat}}(T_\infty) = (15.52 \text{ m}^3/\text{kg})^{-1} = 0.064 \text{ kg/m}^3.$$

Hence,

$$\phi_\infty = 0.351 - \frac{1.135 \text{ kg/m}^3 (1007 \text{ J/kg}\cdot\text{K})(0.88)^{2/3}}{0.064 \text{ kg/m}^3 (2.443 \times 10^6 \text{ J/kg})} (45 - 25) \text{ K}$$

$$\phi_\infty = 0.351 - 0.133 = 0.218.$$

<

**COMMENTS:** Note that latent heat must be evaluated at the surface temperature (evaporation occurs at the surface).

## PROBLEM 6.81

**KNOWN:** Heat transfer correlation for a contoured surface heated from below while experiencing air flow across it. Flow conditions and steady-state temperature when surface experiences evaporation from a thin water film.

**FIND:** (a) Heat transfer coefficient and convection heat rate, (b) Mass transfer coefficient and evaporation rate (kg/h) of the water, (c) Rate at which heat must be supplied to surface for these conditions.

**SCHEMATIC:**

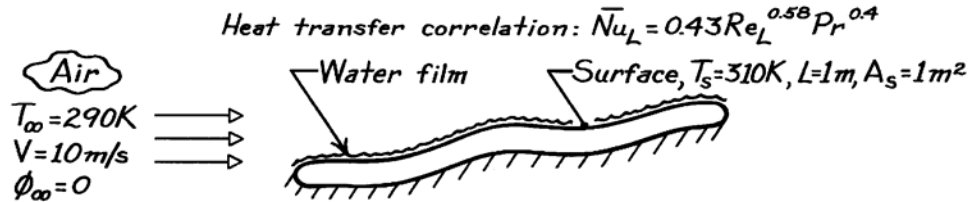

**ASSUMPTIONS:** (1) Steady-state conditions, (2) Heat-mass transfer analogy applies, (3) Correlation requires properties evaluated at  $T_f = (T_s + T_\infty)/2$ .

**PROPERTIES:** Table A-4, Air ( $T_f = (T_s + T_\infty)/2 = (290 + 310)K/2 = 300$  K, 1 atm):  $\nu = 15.89 \times 10^{-6} \text{ m}^2/\text{s}$ ,  $k = 0.0263 \text{ W/m}\cdot\text{K}$ ,  $Pr = 0.707$ ; Table A-8, Air-water mixture (300 K, 1 atm):  $D_{AB} = 0.26 \times 10^{-4} \text{ m}^2/\text{s}$ ; Table A-6, Sat. water ( $T_s = 310$  K):  $\rho_{A,\text{sat}} = 1/v_g = 1/22.93 \text{ m}^3/\text{kg} = 0.04361 \text{ kg/m}^3$ ,  $h_{fg} = 2414 \text{ kJ/kg}$ .

**ANALYSIS:** (a) To characterize the flow, evaluate  $Re_L$  at  $T_f$

$$Re_L = \frac{VL}{\nu} = \frac{10 \text{ m/s} \times 1 \text{ m}}{15.89 \times 10^{-6} \text{ m}^2/\text{s}} = 6.293 \times 10^5$$

and substituting into the prescribed correlation for this surface, find

$$\overline{Nu}_L = 0.43 \left( 6.293 \times 10^5 \right)^{0.58} (0.707)^{0.4} = 864.1$$

$$\overline{h}_L = \frac{\overline{Nu}_L \cdot k}{L} = \frac{864.1 \times 0.0263 \text{ W/m}\cdot\text{K}}{1 \text{ m}} = 22.7 \text{ W/m}^2 \cdot \text{K} \quad <$$

Hence, the convection heat rate is

$$q_{\text{conv}} = \overline{h}_L A_s (T_s - T_\infty)$$

$$q_{\text{conv}} = 22.7 \text{ W/m}^2 \cdot \text{K} \times 1 \text{ m}^2 (310 - 290) \text{ K} = 454 \text{ W} \quad <$$

(b) Invoking the heat-mass transfer analogy

$$\overline{Sh}_L = \frac{\overline{h}_m L}{D_{AB}} = 0.43 Re_L^{0.58} Sc^{0.4}$$

where

$$Sc = \frac{\nu}{D_{AB}} = \frac{15.89 \times 10^{-6} \text{ m}^2/\text{s}}{0.26 \times 10^{-4} \text{ m}^2/\text{s}} = 0.611$$

and  $\nu$  is evaluated at  $T_f$ . Substituting numerical values, find

Continued ...

**PROBLEM 6.81 (Cont.)**

$$\overline{Sh}_L = 0.43 \left( 6.293 \times 10^5 \right)^{0.58} (0.611)^{0.4} = 815.2$$

$$\overline{h}_m = \frac{\overline{Sh}_L \cdot D_{AB}}{L} = \frac{815.2 \times 0.26 \times 10^{-4} \text{ m}^2/\text{s}}{1 \text{ m}} = 2.12 \times 10^{-2} \text{ m/s.} \quad <$$

The evaporation rate, with  $\rho_{A,s} = \rho_{A,\text{sat}}(T_s)$ , is

$$\begin{aligned} \dot{m} &= \overline{h}_m A_s (\rho_{A,s} - \rho_{A,\infty}) \\ \dot{m} &= 2.12 \times 10^{-2} \text{ m/s} \times 1 \text{ m}^2 (0.04361 - 0) \text{ kg/m}^3 \end{aligned}$$

$$\dot{m} = 9.243 \times 10^{-4} \text{ kg/s} = 3.32 \text{ kg/h.} \quad <$$

(c) The rate at which heat must be supplied to the plate to maintain these conditions follows from an energy balance.

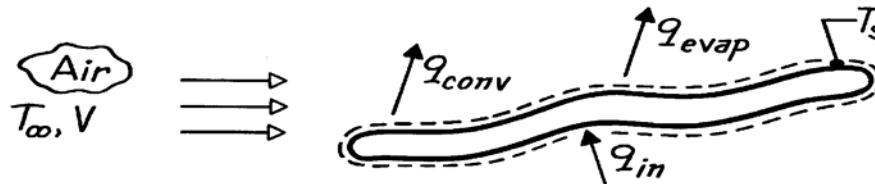

$$\begin{aligned} \dot{E}_{\text{in}} - \dot{E}_{\text{out}} &= 0 \\ q_{\text{in}} - q_{\text{conv}} - q_{\text{evap}} &= 0 \end{aligned}$$

where  $q_{\text{in}}$  is the heat supplied to sustain the losses by convection and evaporation.

$$\begin{aligned} q_{\text{in}} &= q_{\text{conv}} + q_{\text{evap}} \\ q_{\text{in}} &= \overline{h}_L A_s (T_s - T_{\infty}) + \dot{m} h_{fg} \\ q_{\text{in}} &= 454 \text{ W} + 9.243 \times 10^{-4} \text{ kg/s} \times 2414 \times 10^3 \text{ J/kg} \end{aligned}$$

$$q_{\text{in}} = (254 + 2231) \text{ W} = 2685 \text{ W.} \quad <$$

**COMMENTS:** Note that the loss from the surface by evaporation is nearly 5 times that due to convection.

## PROBLEM 6.82

**KNOWN:** Thickness, temperature and evaporative flux of a water layer. Temperature of air flow and surroundings.

**FIND:** (a) Convection mass transfer coefficient and time to completely evaporate the water, (b) Convection heat transfer coefficient, (c) Heater power requirement per surface area, (d) Temperature of dry surface if heater power is maintained.

**SCHEMATIC:**

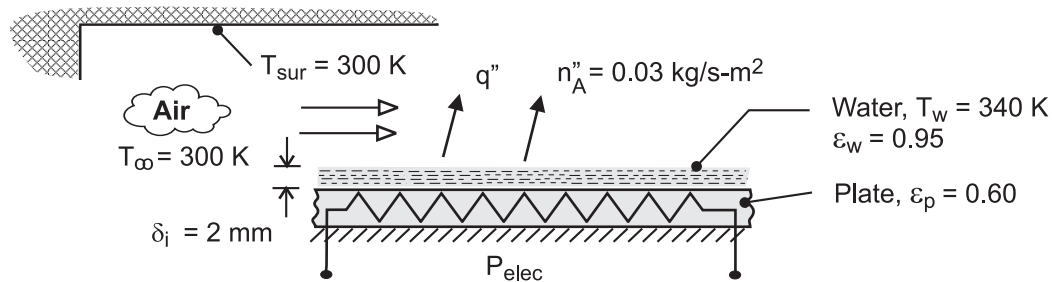

**ASSUMPTIONS:** (1) Steady-state, (2) Applicability of heat and mass transfer analogy with  $n = 1/3$ , (3) Radiation exchange at surface of water may be approximated as exchange between a small surface and large surroundings, (4) Air is dry ( $\rho_{A,\infty} = 0$ ), (5) Negligible heat transfer from unwetted surface of the plate.

**PROPERTIES:** Table A-6, Water ( $T_w = 340\text{K}$ ):  $\rho_f = 979 \text{ kg/m}^3$ ,  $\rho_{A,\text{sat}} = v_g^{-1} = 0.174 \text{ kg/m}^3$ ,  $h_{fg} = 2342 \text{ kJ/kg}$ . Prescribed, Air:  $\rho = 1.08 \text{ kg/m}^3$ ,  $c_p = 1008 \text{ J/kg}\cdot\text{K}$ ,  $k = 0.028 \text{ W/m}\cdot\text{K}$ . Vapor/Air:  $D_{AB} = 0.29 \times 10^{-4} \text{ m}^2/\text{s}$ . Water:  $\epsilon_w = 0.95$ . Plate:  $\epsilon_p = 0.60$ .

**ANALYSIS:** (a) The convection mass transfer coefficient may be determined from the rate equation  $n''_A = h_m (\rho_{A,s} - \rho_{A,\infty})$ , where  $\rho_{A,s} = \rho_{A,\text{sat}}(T_w)$  and  $\rho_{A,\infty} = 0$ . Hence,

$$h_m = \frac{n''_A}{\rho_{A,\text{sat}}} = \frac{0.03 \text{ kg/s}\cdot\text{m}^2}{0.174 \text{ kg/m}^3} = 0.172 \text{ m/s} \quad <$$

The time required to completely evaporate the water is obtained from a mass balance of the form  $-n''_A = \rho_f d\delta/dt$ , in which case

$$\rho_f \int_{\delta_i}^0 d\delta = -n''_A \int_0^t dt$$

$$t = \frac{\rho_f \delta_i}{n''_A} = \frac{979 \text{ kg/m}^3 (0.002 \text{ m})}{0.03 \text{ kg/s}\cdot\text{m}^2} = 65.3 \text{ s} \quad <$$

(b) With  $n = 1/3$  and  $Le = \alpha/D_{AB} = k/\rho c_p D_{AB} = 0.028 \text{ W/m}\cdot\text{K}/(1.08 \text{ kg/m}^3 \times 1008 \text{ J/kg}\cdot\text{K} \times 0.29 \times 10^{-4} \text{ m}^2/\text{s}) = 0.887$ , the heat and mass transfer analogy yields

$$h = \frac{k h_m}{D_{AB} Le^{1/3}} = \frac{0.028 \text{ W/m}\cdot\text{K} (0.172 \text{ m/s})}{0.29 \times 10^{-4} \text{ m}^2/\text{s} (0.887)^{1/3}} = 173 \text{ W/m}^2\cdot\text{K} \quad <$$

The electrical power requirement per unit area corresponds to the rate of heat loss from the water. Hence,

Continued ...

**PROBLEM 6.82 (Cont.)**

$$P''_{\text{elec}} = q''_{\text{evap}} + q''_{\text{conv}} + q''_{\text{rad}} = n''_A h_{fg} + h(T_w - T_\infty) + \varepsilon_w \sigma (T_w^4 - T_{\text{sur}}^4)$$

$$P''_{\text{elec}} = 0.03 \text{ kg/s} \cdot \text{m}^2 \left( 2.342 \times 10^6 \text{ J/kg} \right) + 173 \text{ W/m}^2 \cdot \text{K} (40\text{K}) + 0.95 \times 5.67 \times 10^{-8} \text{ W/m}^2 \cdot \text{K}^4 \left( 340^4 - 300^4 \right)$$

$$P''_{\text{elec}} = 70,260 \text{ W/m}^2 + 6920 \text{ W/m}^2 + 284 \text{ W/m}^2 = 77,464 \text{ W/m}^2 \quad <$$

(c) After complete evaporation, the steady-state temperature of the plate is determined from the requirement that

$$P''_{\text{elec}} = h(T_p - T_\infty) + \varepsilon_p \sigma (T_p^4 - T_{\text{sur}}^4)$$

$$77,464 \text{ W/m}^2 = 173 \text{ W/m}^2 \cdot \text{K} (T_p - 300) + 0.60 \times 5.67 \times 10^{-8} \text{ W/m}^2 \cdot \text{K}^4 (T_p^4 - 300^4)$$

$$T_p = 702\text{K} = 429^\circ\text{C} \quad <$$

**COMMENTS:** The evaporative heat flux is the dominant contributor to heat transfer from the water layer, with convection of sensible energy being an order of magnitude smaller and radiation exchange being negligible. Without evaporation (a dry surface), convection dominates and is approximately an order of magnitude larger than radiation.

### PROBLEM 6.83

**KNOWN:** Heater power required to maintain water film at prescribed temperature in dry ambient air and evaporation rate.

**FIND:** (a) Average mass transfer convection coefficient  $\bar{h}_m$ , (b) Average heat transfer convection coefficient  $\bar{h}$ , (c) Whether values of  $\bar{h}_m$  and  $\bar{h}$  satisfy the heat-mass analogy, and (d) Effect on evaporation rate and disc temperature if relative humidity of the ambient air were increased from 0 to 0.5 but with heater power maintained at the same value.

**SCHEMATIC:**

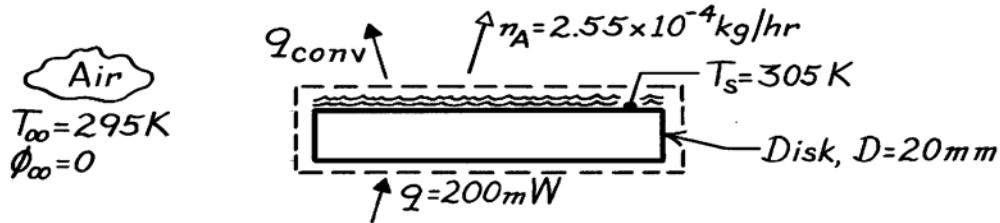

**ASSUMPTIONS:** (1) Water film and disc are at same temperature; (2) Mass and heat transfer coefficient are independent of ambient air relative humidity, (3) Constant properties.

**PROPERTIES:** Table A-6, Saturated water (305 K):  $v_g = 29.74 \text{ m}^3/\text{kg}$ ,  $h_{fg} = 2426 \times 10^3 \text{ J/kg}$ ; Table A-4, Air ( $\bar{T} = 300 \text{ K}$ , 1 atm):  $k = 0.0263 \text{ W/m}\cdot\text{K}$ ,  $\alpha = 22.5 \times 10^{-6} \text{ m}^2/\text{s}$ , Table A-8, Air-water vapor (300 K, 1 atm):  $D_{AB} = 0.26 \times 10^{-4} \text{ m}^2/\text{s}$ .

**ANALYSIS:** (a) Using the mass transfer convection rate equation,

$$n_A = \bar{h}_m A_s (\rho_{A,s} - \rho_{A,\infty}) = \bar{h}_m A_s \rho_{A,\text{sat}} (1 - \phi_\infty)$$

and evaluating  $\rho_{A,s} = \rho_{A,\text{sat}}(305 \text{ K}) = 1/v_g(305 \text{ K})$  with  $\phi_\infty \sim \rho_{A,\infty} = 0$ , find

$$\bar{h}_m = \frac{n_A}{A_s (\rho_{A,s} - \rho_{A,\infty})}$$

$$\bar{h}_m = \frac{2.55 \times 10^{-4} \text{ kg/hr} / (3600 \text{ s/hr})}{\left( \pi (0.020 \text{ m})^2 / 4 \right) (1/29.74 - 0) \text{ kg/m}^3} = 6.71 \times 10^{-3} \text{ m/s.} \quad <$$

(b) Perform an overall energy balance on the disc,

$$q = q_{\text{conv}} + q_{\text{evap}} = \bar{h} A_s (T_s - T_\infty) + n_A h_{fg}$$

and substituting numerical values with  $h_{fg}$  evaluated at  $T_s$ , find  $\bar{h}$ :

$$200 \times 10^{-3} \text{ W} = \bar{h} \pi (0.020 \text{ m})^2 / 4 (305 - 295) \text{ K} + 7.083 \times 10^{-8} \text{ kg/s} \times 2426 \times 10^3 \text{ J/kg}$$

$$\bar{h} = 8.97 \text{ W/m}^2 \cdot \text{K.} \quad <$$

Continued ...



**PROBLEM 6.83 (Cont.)**

(c) The heat-mass transfer analogy, Eq. 6.67, requires that

$$\frac{\bar{h}}{h_m} \stackrel{?}{=} \frac{k}{D_{AB}} \left( \frac{D_{AB}}{\alpha} \right)^{1/3}.$$

Evaluating  $k$  and  $D_{AB}$  at  $\bar{T} = (T_s + T_\infty)/2 = 300 \text{ K}$  and substituting numerical values,

$$\frac{8.97 \text{ W/m}^2 \cdot \text{K}}{6.71 \times 10^{-3} \text{ m/s}} = 1337 \neq \frac{0.0263 \text{ W/m} \cdot \text{K}}{0.26 \times 10^{-4} \text{ m}^2/\text{s}} \left( \frac{0.26 \times 10^{-4} \text{ m}^2/\text{s}}{22.5 \times 10^{-6} \text{ m}^2/\text{s}} \right)^{1/3} = 1061$$

Since the equality is not satisfied, we conclude that, for this situation, the analogy is only approximately met ( $\approx 30\%$ ).

(d) If  $\phi_\infty = 0.5$  instead of 0.0 and  $q$  is unchanged,  $n_A$  will decrease by nearly a factor of two, as will  $n_A h_{fg} = q_{\text{evap}}$ . Hence, since  $q_{\text{conv}}$  must increase and  $\bar{h}$  remains nearly constant,  $T_s - T_\infty$  must increase. Hence,  $T_s$  will increase.

**COMMENTS:** Note that in part (d), with an increase in  $T_s$ ,  $h_{fg}$  decreases, but only slightly, and  $\rho_{A,\text{sat}}$  increases. From a trial-and-error solution assuming constant values for  $\bar{h}_m$  and  $h$ , the disc temperature is 315 K for  $\phi_\infty = 0.5$ .

### PROBLEM 6.84

**KNOWN:** Power-time history required to completely evaporate a droplet of fixed diameter maintained at 37°C.

**FIND:** (a) Average mass transfer convection coefficient when droplet, heater and dry ambient air are at 37°C and (b) Energy required to evaporate droplet if the dry ambient air temperature is 27°C.

**SCHEMATIC:**

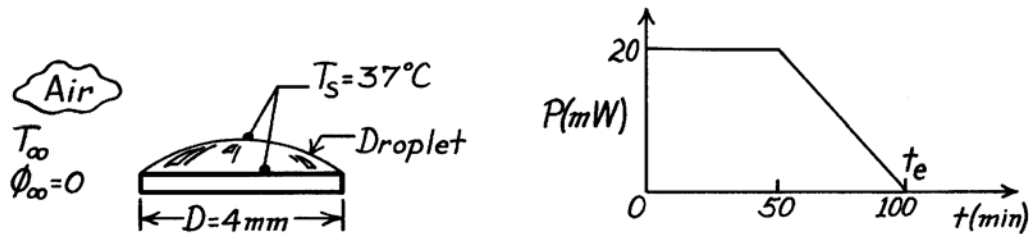

**ASSUMPTIONS:** (1) Wetted surface area of droplet is of fixed diameter  $D$ , (2) Heat-mass transfer analogy is applicable, (3) Heater controlled to operate at constant temperature,  $T_s = 37^\circ\text{C}$ , (4) Mass of droplet same for part (a) and (b), (5) Mass transfer coefficients for parts (a) and (b) are the same.

**PROPERTIES:** Table A-6, Saturated water ( $37^\circ\text{C} = 310\text{ K}$ ):  $h_{fg} = 2414\text{ kJ/kg}$ ,  $\rho_{A,\text{sat}} = 1/v_g = 1/22.93 = 0.04361\text{ kg/m}^3$ ; Table A-8, Air-water vapor ( $T_s = 37^\circ\text{C} = 310\text{ K}$ , 1 atm):  $D_{AB} = 0.26 \times 10^{-6}\text{ m}^2/\text{s} (310/298)^{3/2} = 0.276 \times 10^{-6}\text{ m}^2/\text{s}$ ; Table A-4, Air ( $\bar{T} = (27 + 37)^\circ\text{C}/2 = 305\text{ K}$ , 1 atm):  $\rho = 1.1448\text{ kg/m}^3$ ,  $c_p = 1008\text{ J/kg}\cdot\text{K}$ ,  $\nu = 16.39 \times 10^{-6}\text{ m}^2/\text{s}$ ,  $\text{Pr} = 0.706$ .

**ANALYSIS:** (a) For the isothermal conditions ( $37^\circ\text{C}$ ), the electrical energy  $Q$  required to evaporate the droplet during the interval of time  $\Delta t = t_e$  follows from the area under the  $P$ - $t$  curve above,

$$Q = \int_0^{t_e} P dt = \left[ 20 \times 10^{-3}\text{ W} \times (50 \times 60)\text{ s} + 0.5 \times 20 \times 10^{-3}\text{ W} (100 - 50) \times 60\text{ s} \right]$$

$$Q = 90\text{ J.}$$

From an overall energy balance during the interval of time  $\Delta t = t_e$ , the mass loss due to evaporation is

$$Q = M h_{fg} \quad \text{or} \quad M = Q/h_{fg}$$

$$M = 90\text{ J} / 2414 \times 10^3\text{ J/kg} = 3.728 \times 10^{-5}\text{ kg.}$$

To obtain the average mass transfer coefficient, write the rate equation for an interval of time  $\Delta t = t_e$ ,

$$M = \dot{m} \cdot t_e = \bar{h}_m A_s (\rho_{A,s} - \rho_{A,\infty}) \cdot t_e = \bar{h}_m A_s \rho_{A,s} (1 - \phi_\infty) \cdot t_e$$

Substituting numerical values with  $\phi_\infty = 0$ , find

$$3.278 \times 10^{-5}\text{ kg} = \bar{h}_m \left( \pi (0.004\text{ m})^2 / 4 \right) 0.04361\text{ kg/m}^3 \times (100 \times 60)\text{ s}$$

Continued ...

**PROBLEM 6.84 (Cont.)**

$$\bar{h}_m = 0.0113 \text{ m/s.} \quad <$$

(b) The energy required to evaporate the droplet of mass  $M = 3.728 \times 10^{-5} \text{ kg}$  follows from an overall energy balance,

$$Q = Mh_{fg} + \bar{h}A_s(T_s - T_\infty)$$

where  $\bar{h}$  is obtained from the heat-mass transfer analogy, Eq. 6.60, using  $n = 1/3$ ,

$$\frac{\bar{h}}{h_m} = \frac{k}{D_{AB}Le^n} = \rho c_p Le^{2/3}$$

where

$$Sc = \frac{\nu}{D_{AB}} = \frac{16.39 \times 10^{-6} \text{ m}^2/\text{s}}{0.276 \times 10^{-4} \text{ m}^2/\text{s}} = 0.594$$
$$Le = \frac{Sc}{Pr} = \frac{0.594}{0.706} = 0.841.$$

Hence,

$$\bar{h} = 0.0113 \text{ m/s} \times 1.1448 \text{ kg/m}^3 \times 1008 \text{ J/kg} \cdot \text{K} (0.841)^{2/3} = 11.62 \text{ W/m}^2 \cdot \text{K}.$$

and the energy requirement is

$$Q = 3.728 \times 10^{-5} \text{ kg} \times 2414 \text{ kJ/kg} + 11.62 \text{ W/m}^2 \cdot \text{K} \left( \pi (0.004 \text{ m})^2 / 4 \right) (37 - 27)^\circ \text{C}$$

$$Q = (90.00 + 0.00145) \text{ J} = 90 \text{ J.} \quad <$$

The energy required to meet the convection heat loss is very small compared to that required to sustain the evaporative loss.

## PROBLEM 6.85

**KNOWN:** Initial plate temperature  $T_p(0)$  and saturated air temperature ( $T_\infty$ ) in a dishwasher at the start of the dry cycle. Thermal mass per unit area of the plate  $Mc/A_s = 1600 \text{ J/m}^2 \cdot \text{K}$ .

**FIND:** (a) Differential equation to predict plate temperature as a function of time during the dry cycle and (b) Rate of change in plate temperature at the start of the dry cycle assuming the average convection heat transfer coefficient is  $3.5 \text{ W/m}^2 \cdot \text{K}$ .

**SCHEMATIC:**

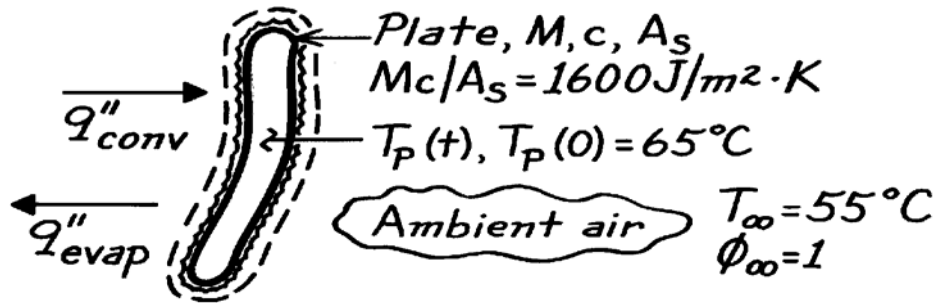

**ASSUMPTIONS:** (1) Plate is spacewise isothermal, (2) Negligible thermal resistance of water film on plate, (3) Heat-mass transfer analogy applies.

**PROPERTIES:** Table A-4, Air ( $\bar{T} = (55 + 65)^\circ\text{C}/2 = 333 \text{ K}$ , 1 atm):  $\rho = 1.0516 \text{ kg/m}^3$ ,  $c_p = 1008 \text{ J/kg} \cdot \text{K}$ ,  $Pr = 0.703$ ,  $\nu = 19.24 \times 10^{-6} \text{ m}^2/\text{s}$ ; Table A-6, Saturated water vapor, ( $T_s = 65^\circ\text{C} = 338 \text{ K}$ ):  $\rho_{A,s} = 1/v_g = 0.1592 \text{ kg/m}^3$ ,  $h_{fg} = 2347 \text{ kJ/kg}$ ; ( $T_s = 55^\circ\text{C} = 328 \text{ K}$ ):  $\rho_{A,\infty} = 1/v_g = 0.1029 \text{ kg/m}^3$ ; Table A-8, Air-water vapor ( $T_s = 65^\circ\text{C} = 338 \text{ K}$ , 1 atm):  $D_{AB} = 0.26 \times 10^{-4} \text{ m}^2/\text{s}$  ( $338/298$ ) $^{3/2} = 0.314 \times 10^{-4} \text{ m}^2/\text{s}$ .

**ANALYSIS:** (a) Perform an energy balance on a rate basis on the plate,

$$\dot{E}_{\text{in}} - \dot{E}_{\text{out}} = \dot{E}_{\text{st}} \quad q''_{\text{conv}} - q''_{\text{evap}} = (Mc/A_s)(dT_p/dt).$$

Using the rate equations for the heat and mass transfer fluxes, find

$$\bar{h}[T_\infty - T_p(t)] - \bar{h}_m[\rho_{A,s}(T_s) - \rho_{A,\infty}(T_\infty)]h_{fg} = (Mc/A_s)(dT/dt). \quad <$$

(b) To evaluate the change in plate temperature at  $t = 0$ , the start of the drying process when  $T_p(0) = 65^\circ\text{C}$  and  $T_\infty = 55^\circ\text{C}$ , evaluate  $\bar{h}_m$  from knowledge of  $\bar{h} = 3.5 \text{ W/m}^2 \cdot \text{K}$  using the heat-mass transfer analogy, Eq. 6.60, with  $n = 1/3$ ,

$$\frac{\bar{h}}{\bar{h}_m} = \rho c_p Le^{2/3} = \rho c_p \left( \frac{Sc}{Pr} \right)^{2/3} = \rho c_p \left( \frac{\nu/D_{AB}}{Pr} \right)^{2/3}$$

and evaluating thermophysical properties at their appropriate temperatures, find

$$\frac{3.5 \text{ W/m}^2 \cdot \text{K}}{\bar{h}_m} = 1.0516 \text{ kg/m}^3 \times 1008 \text{ J/kg} \cdot \text{K} \left( \frac{19.24 \times 10^{-6} \text{ m}^2/\text{s} / 0.314 \times 10^{-4} \text{ m}^2/\text{s}}{0.703} \right)^{2/3} \quad \bar{h}_m = 3.619 \times 10^{-3} \text{ m/s}.$$

Substituting numerical values into the conservation expression of part (a), find

$$3.5 \text{ W/m}^2 \cdot \text{K} (55 - 65)^\circ\text{C} - 3.619 \times 10^{-3} \text{ m/s} (0.1592 - 0.1029) \text{ kg/m}^3 \times 2347 \times 10^3 \text{ J/kg} = 1600 \text{ J/m}^2 \cdot \text{K} (dT_p/dt)$$

$$dT_p/dt = -[35.0 + 478.2] \text{ W/m}^2 \cdot \text{K} / 1600 \text{ J/m}^2 \cdot \text{K} = -0.32 \text{ K/s}. \quad <$$

**COMMENTS:** This rate of temperature change will not be sustained for long, since, as the plate cools, the rate of evaporation (which dominates the cooling process) will diminish.

## PROBLEM 7.1

**KNOWN:** Temperature and velocity of fluids in parallel flow over a flat plate.

**FIND:** (a) Velocity and thermal boundary layer thicknesses at a prescribed distance from the leading edge, and (b) For each fluid plot the boundary layer thicknesses as a function of distance.

**SCHEMATIC:**

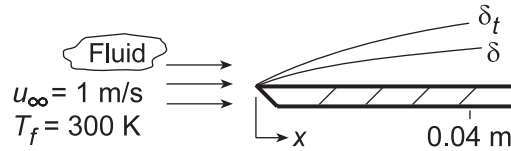

**ASSUMPTIONS:** (1) Transition Reynolds number is  $5 \times 10^5$ .

**PROPERTIES:** Table A.4, Air (300 K, 1 atm):  $\nu = 15.89 \times 10^{-6} \text{ m}^2/\text{s}$ ,  $\text{Pr} = 0.707$ ; Table A.6, Water (300 K):  $\nu = \mu/\rho = 855 \times 10^{-6} \text{ N}\cdot\text{s}/\text{m}^2/997 \text{ kg}/\text{m}^3 = 0.858 \times 10^{-6} \text{ m}^2/\text{s}$ ,  $\text{Pr} = 5.83$ ; Table A.5, Engine Oil (300 K):  $\nu = 550 \times 10^{-6} \text{ m}^2/\text{s}$ ,  $\text{Pr} = 6400$ ; Table A.5, Mercury (300 K):  $\nu = 0.113 \times 10^{-6} \text{ m}^2/\text{s}$ ,  $\text{Pr} = 0.0248$ .

**ANALYSIS:** (a) If the flow is laminar, the following expressions may be used to compute  $\delta$  and  $\delta_t$ , respectively,

$$\delta = \frac{5x}{\text{Re}_x^{1/2}} \quad \delta_t = \frac{\delta}{\text{Pr}^{1/3}}$$

where

$$\text{Re}_x = \frac{u_\infty x}{\nu} = \frac{1 \text{ m/s}(0.04 \text{ m})}{\nu} = \frac{0.04 \text{ m}^2/\text{s}}{\nu}$$

Fluid	$\text{Re}_x$	$\delta$ (mm)	$\delta_t$ (mm)	<
Air	2517	3.99	4.48	
Water	$4.66 \times 10^4$	0.93	0.52	
Oil	72.7	23.5	1.27	
Mercury	$3.54 \times 10^5$	0.34	1.17	

(b) Using IHT with the foregoing equations, the boundary layer thicknesses are plotted as a function of distance from the leading edge,  $x$ .

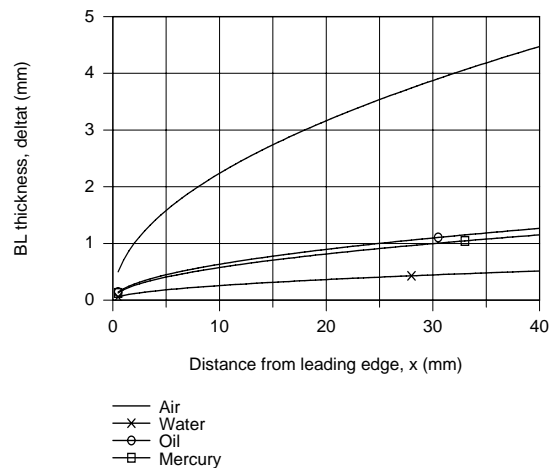
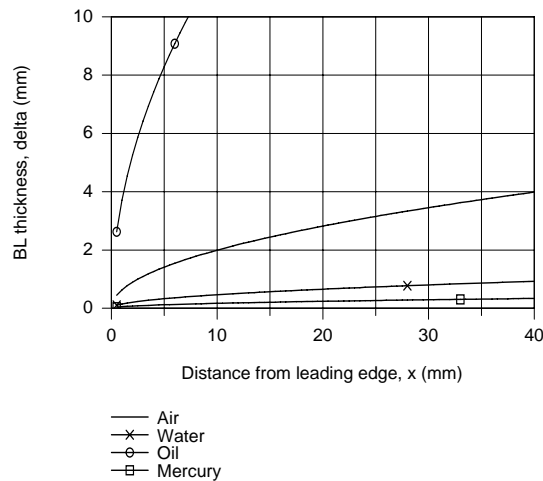

**COMMENTS:** (1) Note that  $\delta \approx \delta_t$  for air,  $\delta > \delta_t$  for water,  $\delta \gg \delta_t$  for oil, and  $\delta < \delta_t$  for mercury. As expected, the boundary layer thicknesses increase with increasing distance from the leading edge.

(2) The value of  $\delta_t$  for mercury should be viewed as a rough approximation since the expression for  $\delta/\delta_t$  was derived subject to the approximation that  $\text{Pr} > 0.6$ .

## PROBLEM 7.2

**KNOWN:** Temperature and velocity of engine oil. Temperature and length of flat plate.

**FIND:** (a) Velocity and thermal boundary layer thickness at trailing edge, (b) Heat flux and surface shear stress at trailing edge, (c) Total drag force and heat transfer per unit plate width, and (d) Plot the boundary layer thickness and local values of the shear stress, convection coefficient, and heat flux as a function of  $x$  for  $0 \leq x \leq 1$  m.

**SCHEMATIC:**

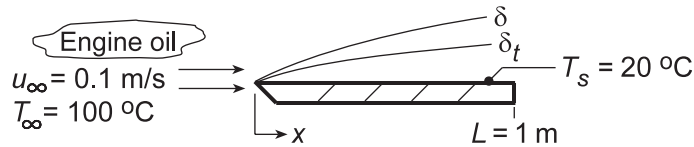

**ASSUMPTIONS:** (1) Critical Reynolds number is  $5 \times 10^5$ , (2) Flow over top and bottom surfaces.

**PROPERTIES:** Table A.5, Engine Oil ( $T_f = 333$  K):  $\rho = 864$  kg/m<sup>3</sup>,  $\nu = 86.1 \times 10^{-6}$  m<sup>2</sup>/s,  $k = 0.140$  W/m·K,  $Pr = 1081$ .

**ANALYSIS:** (a) Calculate the Reynolds number to determine nature of the flow,

$$Re_L = \frac{u_\infty L}{\nu} = \frac{0.1 \text{ m/s} \times 1 \text{ m}}{86.1 \times 10^{-6} \text{ m}^2/\text{s}} = 1161$$

Hence the flow is laminar at  $x = L$ . From Eqs. 7.19 and 7.24,

$$\delta = 5L Re_L^{-1/2} = 5(1 \text{ m})(1161)^{-1/2} = 0.147 \text{ m} \quad <$$

$$\delta_t = \delta Pr^{-1/3} = 0.147 \text{ m}(1081)^{-1/3} = 0.0143 \text{ m} \quad <$$

(b) The local convection coefficient, Eq. 7.23, and heat flux at  $x = L$  are

$$h_L = \frac{k}{L} 0.332 Re_L^{1/2} Pr^{1/3} = \frac{0.140 \text{ W/m} \cdot \text{K}}{1 \text{ m}} 0.332 (1161)^{1/2} (1081)^{1/3} = 16.25 \text{ W/m}^2 \cdot \text{K}$$

$$q''_x = h_L (T_s - T_\infty) = 16.25 \text{ W/m}^2 \cdot \text{K} (20 - 100)^\circ \text{C} = -1300 \text{ W/m}^2 \quad <$$

Also, the local shear stress is, from Eq. 7.20,

$$\tau_{s,L} = \frac{\rho u_\infty^2}{2} 0.664 Re_L^{-1/2} = \frac{864 \text{ kg/m}^3}{2} (0.1 \text{ m/s})^2 0.664 (1161)^{-1/2}$$

$$\tau_{s,L} = 0.0842 \text{ kg/m} \cdot \text{s}^2 = 0.0842 \text{ N/m}^2 \quad <$$

(c) With the drag force per unit width given by  $D' = 2L \bar{\tau}_{s,L}$  where the factor of 2 is included to account for both sides of the plate, it follows from Eq. 7.29 that

$$D' = 2L \left( \frac{\rho u_\infty^2}{2} \right) 1.328 Re_L^{-1/2} = (1 \text{ m}) 864 \text{ kg/m}^3 (0.1 \text{ m/s})^2 1.328 (1161)^{-1/2} = 0.337 \text{ N/m} \quad <$$

For laminar flow, the average value  $\bar{h}_L$  over the distance 0 to  $L$  is twice the local value,  $h_L$ ,

$$\bar{h}_L = 2h_L = 32.5 \text{ W/m}^2 \cdot \text{K}$$

The total heat transfer rate per unit width of the plate is

$$q' = 2L \bar{h}_L (T_s - T_\infty) = 2(1 \text{ m}) 32.5 \text{ W/m}^2 \cdot \text{K} (20 - 100)^\circ \text{C} = -5200 \text{ W/m} \quad <$$

Continued...

## PROBLEM 7.2 (Cont.)

(c) Using IHT with the foregoing equations, the boundary layer thickness, and local values of the convection coefficient and heat flux were calculated and plotted as a function of  $x$ .

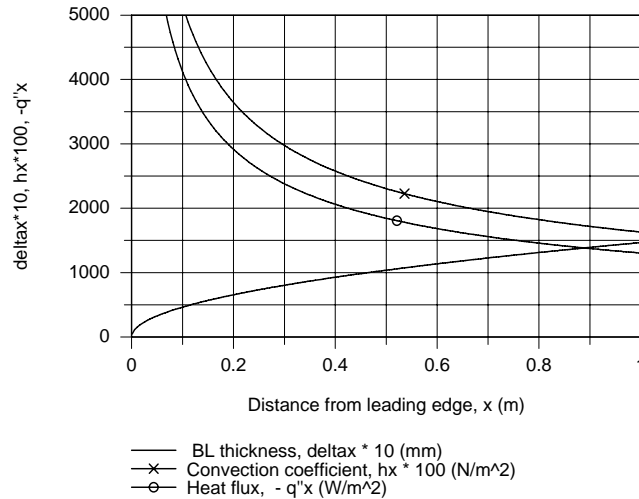

**COMMENTS:** (1) Note that since  $Pr \gg 1$ ,  $\delta \gg \delta_t$ . That is, for the high Prandtl liquids, the velocity boundary layer will be much thicker than the thermal boundary layer.

(2) A copy of the *IHT Workspace* used to generate the above plot is shown below.

```

// Boundary layer thickness, delta
delta = 5 * x * Rex ^-0.5
delta_mm = delta * 1000
delta_plot = delta_mm * 10      // Scaling parameter for convenience in plotting

// Convection coefficient and heat flux, q''x
q''x = hx * (Ts - Tinf)
Nux = 0.332 * Rex^0.5 * Pr^(1/3)
Nux = hx * x / k
hx_plot = 100 * hx              // Scaling parameter for convenience in plotting
q''x_plot = (-1) * q''x        // Scaling parameter for convenience in plotting

// Reynolds number
Rex = uinf * x / nu

// Properties Tool: Engine oil
// Engine Oil property functions : From Table A.5
// Units: T(K)
rho = rho_T("Engine Oil",Tf)    // Density, kg/m^3
cp = cp_T("Engine Oil",Tf)     // Specific heat, J/kg-K
nu = nu_T("Engine Oil",Tf)     // Kinematic viscosity, m^2/s
k = k_T("Engine Oil",Tf)       // Thermal conductivity, W/m-K
Pr = Pr_T("Engine Oil",Tf)     // Prandtl number

// Assigned variables
Tf = (Ts + Tinf) / 2            // Film temperature, K
Tinf = 100 + 273                // Freestream temperature, K
Ts = 20 + 273                  // Surface temperature, K
uinf = 0.1                      // Freestream velocity, m/s
x = 1                          // Plate length, m

```

### PROBLEM 7.3

**KNOWN:** Velocity and temperature of air in parallel flow over a flat plate.

**FIND:** (a) Velocity boundary layer thickness at selected stations. Distance at which boundary layers merge for plates separated by  $H = 3$  mm. (b) Surface shear stress and  $v(\delta)$  at selected stations.

**SCHEMATIC:**

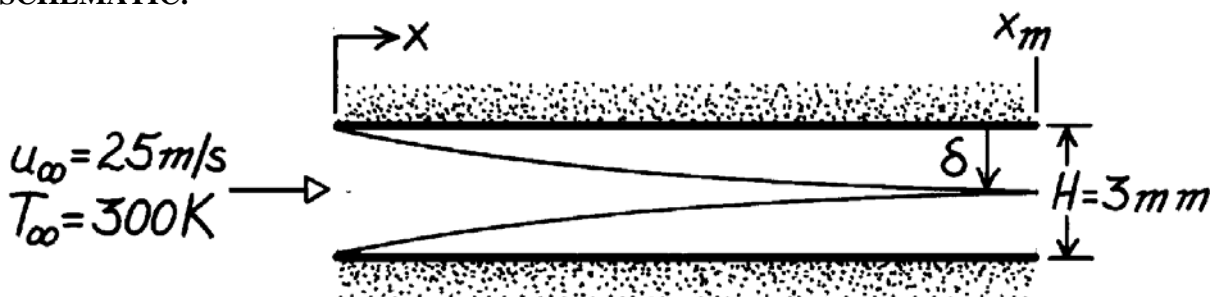

**ASSUMPTIONS:** (1) Steady flow, (2) Boundary layer approximations are valid, (3) Flow is laminar.

**PROPERTIES:** Table A-4, Air (300 K, 1 atm):  $\rho = 1.161 \text{ kg/m}^3$ ,  $\nu = 15.89 \times 10^{-6} \text{ m}^2/\text{s}$ .

**ANALYSIS:** (a) For laminar flow,

$$\delta = \frac{5x}{\text{Re}_x^{1/2}} = \frac{5}{(u_\infty/\nu)^{1/2}} x^{1/2} = \frac{5x^{1/2}}{(25 \text{ m/s}/15.89 \times 10^{-6} \text{ m}^2/\text{s})^{1/2}} = 3.99 \times 10^{-3} x^{1/2}.$$

$x$ (m)	0.001	0.01	0.1
$\delta$ (mm)	0.126	0.399	1.262

Boundary layer merger occurs at  $x = x_m$  when  $\delta = 1.5$  mm. Hence

$$x_m^{1/2} = \frac{0.0015 \text{ m}}{3.99 \times 10^{-3} \text{ m}^{1/2}} = 0.376 \text{ m}^{1/2} \quad x_m = 141 \text{ mm.} \quad <$$

(b) The shear stress is

$$\tau_{s,x} = 0.664 \frac{\rho u_\infty^2 / 2}{\text{Re}_x^{1/2}} = 0.664 \frac{\rho u_\infty^2 / 2}{(u_\infty/\nu)^{1/2} x^{1/2}} = \frac{0.664 \times 1.161 \text{ kg/m}^3 (25 \text{ m/s})^2 / 2}{(25 \text{ m/s}/15.89 \times 10^{-6} \text{ m}^2/\text{s})^{1/2} x^{1/2}} = \frac{0.192}{x^{1/2}} \left( \text{N/m}^2 \right).$$

$x$ (m)	0.001	0.01	0.1
$\tau_{s,x}$ ( $\text{N/m}^2$ )	6.07	1.92	0.61

The velocity distribution in the boundary layer is  $v = (1/2) (\nu u_\infty / x)^{1/2} (\eta df/d\eta - f)$ . At  $y = \delta$ ,  $\eta \approx 5.0$ ,  $f \approx 3.24$ ,  $df/d\eta \approx 0.991$ .

$$v = \frac{0.5}{x^{1/2}} \left( 15.89 \times 10^{-6} \text{ m}^2/\text{s} \times 25 \text{ m/s} \right)^{1/2} (5.0 \times 0.991 - 3.24) = \left( 0.0167 / x^{1/2} \right) \text{ m/s.}$$

$x$ (m)	0.001	0.01	0.1
$v$ (m/s)	0.528	0.167	0.053

**COMMENTS:** (1)  $v \ll u_\infty$  and  $\delta \ll x$  are consistent with BL approximations. Note,  $v \rightarrow \infty$  as  $x \rightarrow 0$  and approximations breakdown very close to the leading edge. (2) Since  $\text{Re}_{x_m} = 2.22 \times 10^5$ , laminar BL model is valid. (3) Above expressions are approximations for flow between parallel plates, since  $du_\infty/dx > 0$  and  $dp/dx < 0$ .



## PROBLEM 7.4

**KNOWN:** Liquid metal in parallel flow over a flat plate.

**FIND:** An expression for the local Nusselt number.

**SCHEMATIC:**

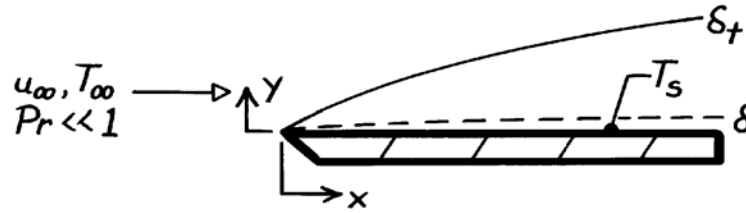

**ASSUMPTIONS:** (1) Steady, incompressible flow, (2)  $\delta \ll \delta_t$ , hence  $u(y) \approx u_\infty$ , (3) Boundary layer approximations are valid, (4) Constant properties.

**ANALYSIS:** The boundary layer energy equation is

$$u \frac{\partial T}{\partial x} + v \frac{\partial T}{\partial y} = \alpha \frac{\partial^2 T}{\partial y^2}.$$

Assuming  $u(y) = u_\infty$ , it follows that  $v = 0$  and the energy equation becomes

$$u_\infty \frac{\partial T}{\partial x} = \alpha \frac{\partial^2 T}{\partial y^2} \quad \text{or} \quad \frac{\partial T}{\partial x} = \frac{\alpha}{u_\infty} \frac{\partial^2 T}{\partial y^2}.$$

*Boundary Conditions:*  $T(x,0) = T_s$ ,  $T(x,\infty) = T_\infty$ .

*Initial Condition:*  $T(0,y) = T_\infty$ .

The differential equation is analogous to that for transient one-dimensional conduction in a plane wall, and the conditions are analogous to those of Fig. 5.7, Case (1). Hence the solution is given by Eqs.

5.60 and 5.61. Substituting  $y$  for  $x$ ,  $x$  for  $t$ ,  $T_\infty$  for  $T_i$ , and  $\alpha/u_\infty$  for  $\alpha$ , the boundary layer temperature and the surface heat flux become

$$\frac{T(x,y) - T_s}{T_\infty - T_s} = \text{erf} \left[ \frac{y}{2(\alpha x/u_\infty)^{1/2}} \right]$$

$$q_s'' = \frac{k(T_s - T_\infty)}{(\pi \alpha x/u_\infty)^{1/2}}.$$

Hence, with 
$$\text{Nu}_x \equiv \frac{h x}{k} = \frac{q_s'' x}{(T_s - T_\infty) k}$$

find 
$$\text{Nu}_x = \frac{x}{(\pi \alpha x/u_\infty)^{1/2}} = \frac{(x u_\infty)^{1/2}}{\pi^{1/2} (k/\rho c_p)^{1/2}} = \frac{1}{\pi^{1/2}} \left[ \frac{\rho u_\infty x}{\mu} \cdot \frac{c_p \mu}{k} \right]^{1/2}$$

$$\text{Nu}_x = 0.564 (\text{Re}_x \text{Pr})^{1/2} = 0.564 \text{Pe}^{1/2} \quad <$$

where  $\text{Pe} = \text{Re} \cdot \text{Pr}$  is the Peclet number.

**COMMENTS:** Because  $k$  is very large, axial conduction effects may not be negligible. That is, the  $\alpha \frac{\partial^2 T}{\partial x^2}$  term of the energy equation may be important.

## PROBLEM 7.5

**KNOWN:** Form of velocity profile for flow over a flat plate.

**FIND:** (a) Expression for profile in terms of  $u_\infty$  and  $\delta$ , (b) Expression for  $\delta(x)$ , (c) Expression for  $C_{f,x}$ .

**SCHEMATIC:**

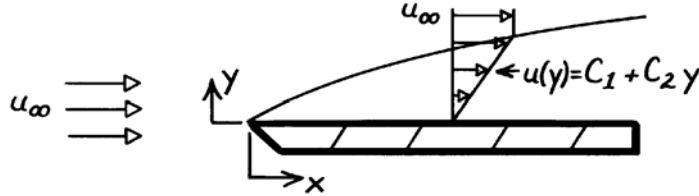

**ASSUMPTIONS:** (1) Steady state conditions, (2) Constant properties, (3) Incompressible flow, (4) Boundary layer approximations are valid.

**ANALYSIS:** (a) From the boundary conditions

$$u(x, 0) = 0 \rightarrow C_1 = 0 \quad \text{and} \quad u(x, \delta) = u_\infty \rightarrow C_2 = u_\infty / \delta.$$

Hence,  $u = u_\infty (y/\delta)$ . <

(b) From the momentum integral equation for a flat plate

$$\begin{aligned} \frac{d}{dx} \int_0^\delta (u_\infty - u) u \, dy &= \tau_s / \rho \\ u_\infty^2 \frac{d}{dx} \int_0^\delta \left(1 - \frac{u}{u_\infty}\right) \frac{u}{u_\infty} \, dy &= \left. \frac{\mu}{\rho} \frac{\partial u}{\partial y} \right|_{y=0} = \frac{\nu u_\infty}{\delta} \\ u_\infty^2 \frac{d}{dx} \int_0^\delta \left(1 - \frac{y}{\delta}\right) \frac{y}{\delta} \, dy &= \frac{\nu u_\infty}{\delta} \\ u_\infty^2 \frac{d}{dx} \left[ \left( \frac{y^2}{2\delta} - \frac{y^3}{3\delta^2} \right) \Big|_0^\delta \right] &= \frac{\mu u_\infty}{\delta} \quad \text{or} \quad \frac{u_\infty}{6} \frac{d\delta}{dx} = \frac{\nu}{\delta}. \end{aligned}$$

Separating and integrating, find

$$\int_0^\delta \delta \, d\delta = \frac{6\nu}{u_\infty} \int_0^x dx \quad \delta = \left( \frac{12 \nu x}{u_\infty} \right)^{1/2} = 3.46 x \left( \frac{\nu}{u_\infty x} \right)^{1/2} = 3.46 x \text{Re}_x^{-1/2}. \quad <$$

(c) The shear stress at the wall is

$$\tau_s = \left. \mu \frac{\partial u}{\partial y} \right|_{y=0} = \mu \frac{u_\infty}{\delta} = \frac{\mu u_\infty}{3.46 x} \text{Re}_x^{1/2}$$

and the friction coefficient is

$$C_{f,x} = \frac{\tau_s}{\rho u_\infty^2 / 2} = \frac{\mu}{\rho u_\infty x} \frac{2}{3.46} \text{Re}_x^{1/2} = 0.578 \text{Re}_x^{-1/2}. \quad <$$

**COMMENTS:** The foregoing results underpredict those associated with the exact solution  $(\delta = 4.96 x \text{Re}_x^{-1/2}, C_{f,x} = 0.664 \text{Re}_x^{-1/2})$  and the cubic profile  $(\delta = 4.64 x \text{Re}_x^{-1/2}, C_{f,x} = 0.646 \text{Re}_x^{-1/2})$ .

### PROBLEM 7.6

**KNOWN:** Velocity and temperature profiles and shear stress-boundary layer thickness relation for turbulent flow over a flat plate.

**FIND:** (a) Expressions for hydrodynamic boundary layer thickness and average friction coefficient, (b) Expressions for local and average Nusselt numbers.

**SCHEMATIC:**

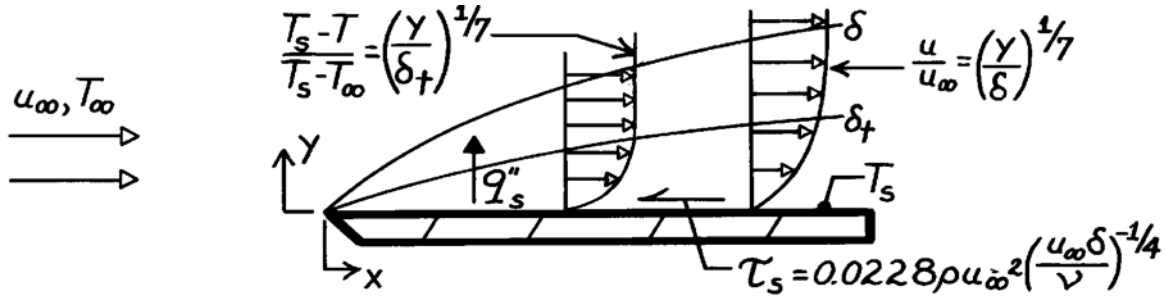

**ASSUMPTIONS:** (1) Steady flow, (2) Constant properties, (3) Fully turbulent boundary layer, (4) Incompressible flow, (5) Isothermal plate, (6) Negligible viscous dissipation, (7)  $\delta \approx \delta_t$ .

**ANALYSIS:** (a) The momentum integral equation is

$$\rho u_\infty^2 \frac{d}{dx} \int_0^\delta \left(1 - \frac{u}{u_\infty}\right) \frac{u}{u_\infty} dy = \tau_s.$$

Substituting the expression for the wall shear stress

$$\rho u_\infty^2 \frac{d}{dx} \int_0^\delta \left[1 - \left(\frac{y}{\delta}\right)^{1/7}\right] \left(\frac{y}{\delta}\right)^{1/7} dy = 0.0228 \rho u_\infty^2 \left(\frac{u_\infty \delta}{\nu}\right)^{-1/4}$$

$$\frac{d}{dx} \int_0^\delta \left[\left(\frac{y}{\delta}\right)^{1/7} - \left(\frac{y}{\delta}\right)^{2/7}\right] dy = \frac{d}{dx} \left[\frac{7}{8} \frac{y^{8/7}}{\delta^{1/7}} - \frac{7}{9} \frac{y^{9/7}}{\delta^{2/7}}\right] \Big|_0^\delta$$

$$\frac{d}{dx} \left(\frac{7}{8} \delta - \frac{7}{9} \delta\right) = 0.0228 \left(\frac{u_\infty \delta}{\nu}\right)^{-1/4}$$

$$\frac{7}{72} \frac{d\delta}{dx} = 0.0228 \left(\frac{\nu}{u_\infty}\right)^{1/4} \delta^{-1/4} \quad \frac{7}{72} \int_0^\delta \delta^{1/4} d\delta = 0.0228 \left(\frac{\nu}{u_\infty}\right)^{1/4} \int_0^x dx$$

$$\frac{7}{72} \times \frac{4}{5} \delta^{5/4} = 0.0228 \left(\frac{\nu}{u_\infty}\right)^{1/4} x, \quad \delta = 0.376 \left(\frac{\nu}{u_\infty}\right)^{1/5} x^{4/5}, \quad \frac{\delta}{x} = 0.376 \text{Re}_x^{-1/5}. <$$

Knowing  $\delta$ , it follows

$$\tau_s = 0.0228 \rho u_\infty^2 \left(\frac{u_\infty}{\nu}\right)^{-1/4} \left[0.376 x \text{Re}_x^{-1/5}\right]^{-1/4}$$

$$C_{f,x} = \frac{\tau_s}{\rho u_\infty^2 / 2} = 0.0456 \left[0.376 \frac{u_\infty}{\nu} \left(\frac{u_\infty}{\nu}\right)^{-1/5} x x^{-1/5}\right]^{-1/4} = 0.0582 \text{Re}_x^{-1/5}.$$

Continued ...

### PROBLEM 7.6 (Cont.)

The average friction coefficient is then

$$\bar{C}_{f,x} = \frac{1}{x} \int_0^x C_{f,x} dx = \frac{1}{x} 0.0582 \left( \frac{u_\infty}{\nu} \right)^{-1/5} \int_0^x x^{-1/5} dx$$

$$\bar{C}_{f,x} = \frac{1}{x} 0.0582 \left( \frac{u_\infty}{\nu} \right)^{-1/5} x^{4/5} \left( \frac{5}{4} \right) = 0.073 \text{Re}_x^{-1/5}. \quad <$$

(b) The energy integral equation for turbulent flow is

$$\frac{d}{dx} \int_0^{\delta_t} u(T_\infty - T) dy = \frac{q_s''}{\rho c_p} = -\frac{h}{\rho c_p} (T_s - T_\infty).$$

Hence,

$$u_\infty \frac{d}{dx} \int_0^{\delta_t} \frac{u}{u_\infty} \frac{T - T_\infty}{T_s - T_\infty} dy = u_\infty \frac{d}{dx} \int_0^{\delta_t} (y/\delta)^{1/7} \left[ 1 - (y/\delta_t)^{1/7} \right] dy = \frac{h}{\rho c_p}$$

$$u_\infty \frac{d}{dx} \left[ \frac{7}{8} \frac{\delta_t^{8/7}}{\delta^{1/7}} - \frac{7}{9} \frac{\delta_t^{8/7}}{\delta^{1/7}} \right] = \frac{h}{\rho c_p}$$

or, with  $\xi \equiv \delta_t / \delta$ ,

$$u_\infty \frac{d}{dx} \left[ \frac{7}{8} \delta \xi^{8/7} - \frac{7}{9} \delta \xi^{8/7} \right] = \frac{h}{\rho c_p} \quad u_\infty \frac{d}{dx} \left[ \frac{7}{72} \delta \xi^{8/7} \right] = \frac{h}{\rho c_p}.$$

Hence, with  $\xi \approx 1$  and  $\delta/x = 0.376 \text{Re}_x^{-1/5}$ ,

$$\frac{7}{72} u_\infty (0.376) \left( \frac{u_\infty}{\nu} \right)^{-1/5} \frac{d(x^{4/5})}{dx} = \frac{h}{\rho c_p}$$

$$h = 0.0292 \rho c_p u_\infty \text{Re}_x^{-1/5} = 0.0292 \frac{k}{x} \frac{\nu}{\alpha} \frac{u_\infty x}{\nu} \text{Re}_x^{-1/5}$$

$$\text{Nu}_x = \frac{hx}{k} = 0.0292 \text{Re}_x^{4/5} \text{Pr}. \quad <$$

Hence,

$$\bar{h}_x = \frac{1}{x} \int_0^x h dx = \frac{0.0292 \text{Pr}}{x} k \left( \frac{u_\infty}{\nu} \right)^{4/5} \int_0^x x^{-1/5} dx = 0.0292 \frac{k}{x} \text{Pr} \left( \frac{u_\infty x}{\nu} \right)^{4/5} \frac{5}{4}$$

$$\bar{\text{Nu}}_x = \frac{\bar{h}_x x}{k} = 0.037 \text{Re}_x^{4/5} \text{Pr}. \quad <$$

**COMMENTS:** (1) The foregoing results are in excellent agreement with empirical correlations, except that use of  $\text{Pr}^{1/3}$  instead of  $\text{Pr}$ , would be more appropriate. This result arose because of the assumption  $\delta \approx \delta_t$ , which is only valid for  $\text{Pr} \approx 1$ .

(2) Note that the 1/7 profile breaks down at the surface. For example,

$$\left. \frac{\partial(u/u_\infty)}{\partial y} \right)_{y=0} = \frac{1}{7} \delta^{-1/7} y^{-6/7} = \infty$$

or  $\tau_s = \infty$ . Despite this unrealistic characteristic of the profile, its use with integral methods provides excellent results.

## PROBLEM 7.7

**KNOWN:** Parallel flow over a flat plate and two locations representing a short span  $x_1$  to  $x_2$  where  $(x_2 - x_1) \ll L$ .

**FIND:** Three different expressions for the average heat transfer coefficient over the short span  $x_1$  to  $x_2$ ,  $\bar{h}_{1-2}$ .

**SCHEMATIC:**

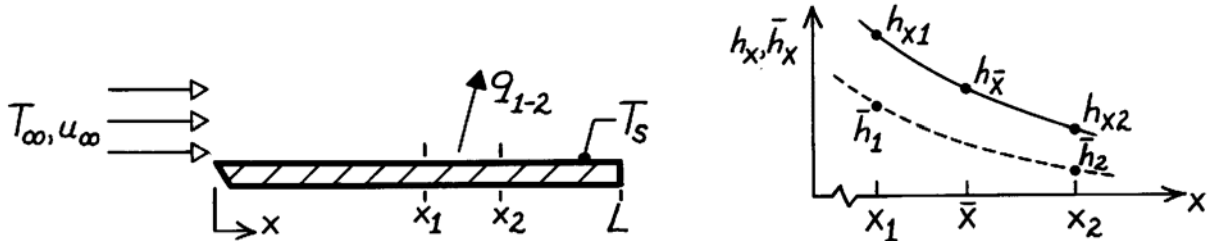

**ASSUMPTIONS:** (1) Parallel flow over a flat plate.

**ANALYSIS:** The heat rate per unit width for the span can be written as

$$q'_{1-2} = \bar{h}_{1-2} (x_2 - x_1) (T_s - T_\infty) \quad (1)$$

where  $\bar{h}_{1-2}$  is the average heat transfer coefficient over the span and can be evaluated in either of the following three ways:

(a) *Local coefficient at  $\bar{x} = (x_1 + x_2)/2$ .* If the span is very short, it is reasonable to assume that

$$\bar{h}_{1-2} \approx h_{\bar{x}} \quad (2)$$

where  $h_{\bar{x}}$  is the local convection coefficient at the mid-point of the span.

(b) *Local coefficients at  $x_1$  and  $x_2$ .* If the span is very short it is reasonable to assume that  $\bar{h}_{1-2}$  is the average of the local values at the ends of the span,

$$\bar{h}_{1-2} \approx [h_{x1} + h_{x2}] / 2. \quad (3)$$

(c) *Average coefficients for  $x_1$  and  $x_2$ .* The heat rate for the span can also be written as

$$q'_{1-2} = q'_{0-2} - q'_{0-1} \quad (4)$$

where the rate  $q'_{0-x}$  denotes the heat rate for the plate over the distance from 0 to  $x$ . In terms of heat transfer coefficients, find

$$\begin{aligned} \bar{h}_{1-2} \cdot (x_2 - x_1) &= \bar{h}_2 \cdot x_2 - \bar{h}_1 \cdot x_1 \\ \bar{h}_{1-2} &= \bar{h}_2 \frac{x_2}{x_2 - x_1} - \bar{h}_1 \frac{x_1}{x_2 - x_1} \end{aligned} \quad (5)$$

where  $\bar{h}_1$  and  $\bar{h}_2$  are the average coefficients from 0 to  $x_1$  and  $x_2$ , respectively.

**COMMENTS:** Eqs. (2) and (3) are approximate and work better when the span is small and the flow is turbulent rather than laminar ( $h_x \sim x^{-0.2}$  vs  $h_x \sim x^{-0.5}$ ). Of course, we require that  $x_c < x_1, x_2$  or  $x_c > x_1, x_2$ ; that is, the approximations are inappropriate around the transition region. Eq. (5) is an exact relationship, which applies under any conditions.

## PROBLEM 7.8

**KNOWN:** Flat plate comprised of rectangular modules of surface temperature  $T_s$ , thickness  $a$  and length  $b$  cooled by air at  $25^\circ\text{C}$  and a velocity of  $30\text{ m/s}$ . Prescribed thermophysical properties of the module material.

**FIND:** (a) Required power generation for the module positioned  $700\text{ mm}$  from the leading edge of the plate and (b) Maximum temperature in this module.

**SCHEMATIC:**

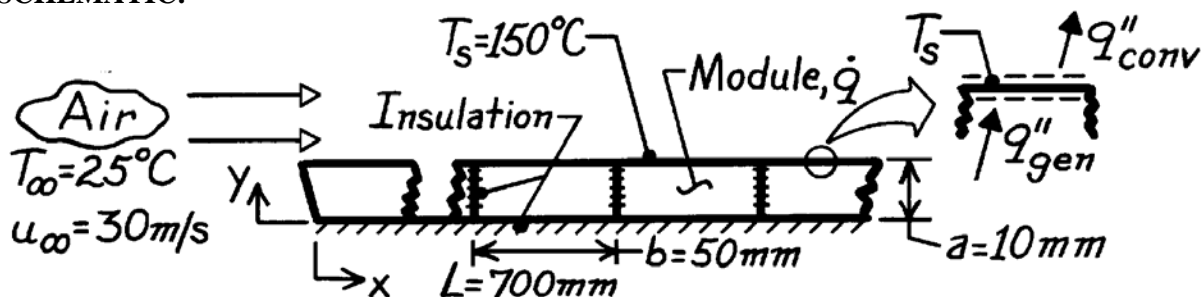

**ASSUMPTIONS:** (1) Laminar flow at leading edge of plate, (2) Transition Reynolds number of  $5 \times 10^5$ , (3) Heat transfer is one-dimensional in  $y$ -direction within each module, (4)  $\dot{q}$  is uniform within module, (5) Negligible radiation heat transfer.

**PROPERTIES:** Module material (given):  $k = 5.2\text{ W/m}\cdot\text{K}$ ,  $c_p = 320\text{ J/kg}\cdot\text{K}$ ,  $\rho = 2300\text{ kg/m}^3$ ; Table A-4, Air ( $\bar{T}_f = (T_s + T_\infty)/2 = 360\text{ K}$ ,  $1\text{ atm}$ ):  $k = 0.0308\text{ W/m}\cdot\text{K}$ ,  $\nu = 22.02 \times 10^{-6}\text{ m}^2/\text{s}$ ,  $\text{Pr} = 0.698$ .

**ANALYSIS:** (a) The module power generation follows from an energy balance on the module surface,

$$q''_{\text{conv}} = q''_{\text{gen}}$$

$$\bar{h}(T_s - T_\infty) = \dot{q} \cdot a \quad \text{or} \quad \dot{q} = \frac{\bar{h}(T_s - T_\infty)}{a}.$$

To select a convection correlation for estimating  $\bar{h}$ , first find the Reynolds numbers at  $x = L$ .

$$\text{Re}_L = \frac{u_\infty L}{\nu} = \frac{30\text{ m/s} \times 0.70\text{ m}}{22.02 \times 10^{-6}\text{ m}^2/\text{s}} = 9.537 \times 10^5.$$

Since the flow is turbulent over the module, the approximation  $\bar{h} \approx h_x(L + b/2)$  is appropriate, with

$$\text{Re}_{L+b/2} = \frac{30\text{ m/s} \times (0.700 + 0.050/2)\text{ m}}{22.02 \times 10^{-6}\text{ m}^2/\text{s}} = 9.877 \times 10^5.$$

Using the turbulent flow correlation with  $x = L + b/2 = 0.725\text{ m}$ ,

$$\text{Nu}_x = \frac{h_x x}{k} = 0.0296 \text{Re}_x^{4/5} \text{Pr}^{1/3}$$

$$\text{Nu}_x = 0.0296 (9.877 \times 10^5)^{4/5} (0.698)^{1/3} = 1640$$

$$\bar{h} \approx h_x = \frac{\text{Nu}_x k}{x} = \frac{1640 \times 0.0308\text{ W/m}\cdot\text{K}}{0.725} = 69.7\text{ W/m}^2 \cdot \text{K}.$$

Continued ...

**PROBLEM 7.8 (Cont.)**

Hence,

$$\dot{q} = \frac{69.7 \text{ W/m}^2 \cdot \text{K} (150 - 25) \text{ K}}{0.010 \text{ m}} = 8.713 \times 10^5 \text{ W/m}^3. \quad <$$

(b) The maximum temperature within the module occurs at the surface next to the insulation ( $y = 0$ ). For one-dimensional conduction with thermal energy generation, use Eq. 3.42 to obtain

$$T(0) = \frac{\dot{q}a^2}{2k} + T_s = \frac{8.713 \times 10^5 \text{ W/m}^3 \times (0.010 \text{ m})^2}{2 \times 5.2 \text{ W/m} \cdot \text{K}} + 150^\circ \text{C} = 158.4^\circ \text{C}. \quad <$$

**COMMENTS:** An alternative approach for estimating the average heat transfer coefficient for the module follows from the relation

$$q_{\text{module}} = q_{0 \rightarrow L+b} - q_{0 \rightarrow L}$$

$$\bar{h} \cdot b = \bar{h}_{L+b} \cdot (L+b) - \bar{h}_L \cdot L \quad \text{or} \quad \bar{h} = \bar{h}_{L+b} \frac{L+b}{b} - \bar{h}_L \frac{L}{b}.$$

Recognizing that laminar and turbulent flow conditions exist, the appropriate correlation is

$$\overline{\text{Nu}}_x = \left( 0.037 \text{Re}_x^{4/5} - 871 \right) \text{Pr}^{1/3}$$

With  $x = L + b$  and  $x = L$ , find

$$\bar{h}_{L+b} = 54.79 \text{ W/m}^2 \cdot \text{K} \quad \text{and} \quad \bar{h}_L = 53.73 \text{ W/m}^2 \cdot \text{K}.$$

Hence,

$$\bar{h} = \left[ 54.79 \frac{0.750}{0.050} - 53.73 \frac{0.700}{0.05} \right] \text{ W/m}^2 \cdot \text{K} = 69.7 \text{ W/m}^2 \cdot \text{K}.$$

which is in excellent agreement with the approximate result employed in part (a).

## PROBLEM 7.9

**KNOWN:** Dimensions and surface temperature of electrically heated strips. Temperature and velocity of air in parallel flow.

**FIND:** (a) Rate of convection heat transfer from first, fifth and tenth strips as well as from all the strips, (b) For air velocities of 2, 5 and 10 m/s, determine the convection heat rates for all the locations of part (a), and (c) Repeat the calculations of part (b), but under conditions for which the flow is fully turbulent over the entire array of strips.

**SCHEMATIC:**

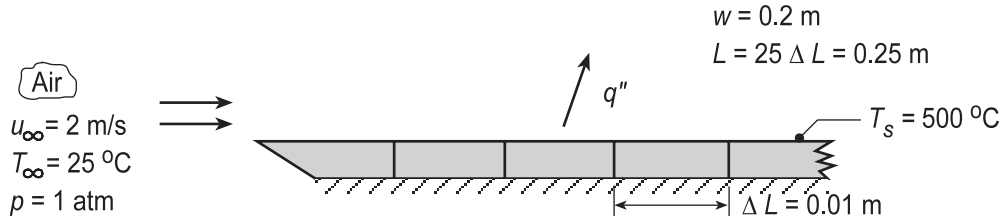

**ASSUMPTIONS:** (1) Top surface is smooth, (2) Bottom surface is adiabatic, (3) Critical Reynolds number is  $5 \times 10^5$ , (4) Negligible radiation.

**PROPERTIES:** Table A.4, Air ( $T_f = 535$  K, 1 atm):  $\nu = 43.54 \times 10^{-6}$  m<sup>2</sup>/s,  $k = 0.0429$  W/m·K,  $Pr = 0.683$ .

**ANALYSIS:** (a) The location of transition is determined from

$$x_c = 5 \times 10^5 \frac{\nu}{u_\infty} = 5 \times 10^5 \frac{43.54 \times 10^{-6} \text{ m}^2/\text{s}}{2 \text{ m/s}} = 10.9 \text{ m}$$

Since  $x_c \gg L = 0.25$  m, the air flow is laminar over the entire heater. For the *first* strip,  $q_1 = \bar{h}_1 (\Delta L \times w)(T_s - T_\infty)$  where  $\bar{h}_1$  is obtained from

$$\bar{h}_1 = \frac{k}{\Delta L} 0.664 \text{Re}_x^{1/2} \text{Pr}^{1/3}$$

$$\bar{h}_1 = \frac{0.0429 \text{ W/m} \cdot \text{K}}{0.01 \text{ m}} \times 0.664 \left( \frac{2 \text{ m/s} \times 0.01 \text{ m}}{43.54 \times 10^{-6} \text{ m}^2/\text{s}} \right)^{1/2} (0.683)^{1/3} = 53.8 \text{ W/m}^2 \cdot \text{K}$$

$$q_1 = 53.8 \text{ W/m}^2 \cdot \text{K} (0.01 \text{ m} \times 0.2 \text{ m}) (500 - 25)^\circ \text{C} = 51.1 \text{ W} \quad <$$

For the *fifth* strip,  $q_5 = q_{0-5} - q_{0-4}$ ,

$$q_5 = h_{0-5} (5\Delta L \times w)(T_s - T_\infty) - \bar{h}_{0-4} (4\Delta L \times w)(T_s - T_\infty)$$

$$q_5 = (5\bar{h}_{0-5} - 4\bar{h}_{0-4})(\Delta L \times w)(T_s - T_\infty)$$

Hence, with  $x_5 = 5\Delta L = 0.05$  m and  $x_4 = 4\Delta L = 0.04$  m, it follows that  $\bar{h}_{0-5} = 24.1$  W/m<sup>2</sup>·K and  $\bar{h}_{0-4} = 26.9$  W/m<sup>2</sup>·K and

$$q_5 = (5 \times 24.1 - 4 \times 26.9) \text{ W/m}^2 \cdot \text{K} (0.01 \times 0.2) \text{ m}^2 (500 - 25) \text{ K} = 12.2 \text{ W} \quad <$$

Similarly, where  $\bar{h}_{0-10} = 17.00$  W/m<sup>2</sup>·K and  $\bar{h}_{0-9} = 17.92$  W/m<sup>2</sup>·K.

$$q_{10} = (10\bar{h}_{0-10} - 9\bar{h}_{0-9})(\Delta L \times w)(T_s - T_\infty)$$

$$q_{10} = (10 \times 17.00 - 9 \times 17.92) \text{ W/m}^2 \cdot \text{K} (0.01 \times 0.2) \text{ m}^2 (500 - 25) \text{ K} = 8.3 \text{ W} \quad <$$

Continued...



### PROBLEM 7.9 (Cont.)

For the entire heater,

$$\bar{h}_{0-25} = \frac{k}{L} 0.664 \text{Re}_L^{1/2} \text{Pr}^{1/3} = \frac{0.0429}{0.25} \times 0.664 \left( \frac{2 \times 0.25}{43.54 \times 10^{-6}} \right)^{1/2} (0.683)^{1/3} = 10.75 \text{ W/m}^2 \cdot \text{K}$$

and the heat rate over all 25 strips is

$$q_{0-25} = \bar{h}_{0-25} (L \times w) (T_s - T_\infty) = 10.75 \text{ W/m}^2 \cdot \text{K} (0.25 \times 0.2) \text{ m}^2 (500 - 25)^\circ \text{C} = 255.3 \text{ W} <$$

(b,c) Using the *IHT Correlations Tool, External Flow*, for *Laminar or Mixed Flow Conditions*, and following the same method of solution as above, the heat rates for the first, fifth, tenth and all the strips were calculated for air velocities of 2, 5 and 10 m/s. To evaluate the heat rates for fully turbulent conditions, the analysis was performed setting  $\text{Re}_{x,c} = 1 \times 10^6$ . The results are tabulated below.

Flow conditions	$u_\infty$ (m/s)	$q_1$ (W)	$q_5$ (W)	$q_{10}$ (W)	$q_{0-25}$ (W)
Laminar	2	51.1	12.1	8.3	256
	5	80.9	19.1	13.1	404
	10	114	27.0	18.6	572
Fully turbulent	2	17.9	10.6	9.1	235
	5	37.3	22.1	19.0	490
	10	64.9	38.5	33.1	853

**COMMENTS:** (1) An alternative approach to evaluating the heat loss from a single strip, for example, strip 5, would take the form  $q_5 = \bar{h}_5 (\Delta L \times w) (T_s - T_\infty)$ , where  $h_5 \approx h_{x=4.5\Delta L}$  or  $\bar{h}_5 \approx (h_{x=5\Delta L} + h_{x=4\Delta L})/2$ .

(2) From the tabulated results, note that for both flow conditions, the heat rate for each strip and the entire heater, increases with increasing air velocity. For both flow conditions and for any specified velocity, the strip heat rates decrease with increasing distance from the leading edge.

(3) To more fully appreciate the effects due to laminar vs. turbulent flow conditions and air velocity, it is useful to examine the local coefficient as a function of distance from the leading edge. How would you use the results plotted below to explain heat rate behavior evident in the summary table above?

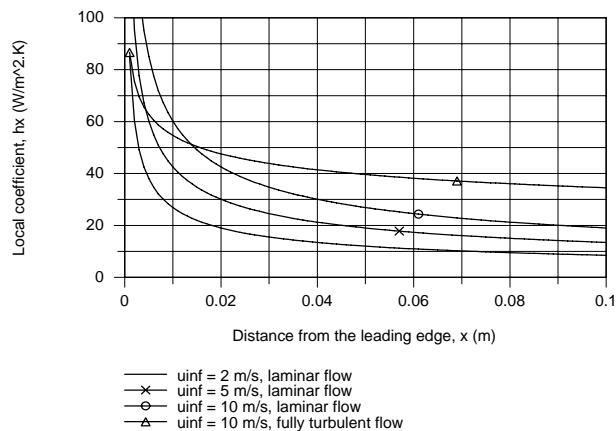

### PROBLEM 7.10

**KNOWN:** Speed and temperature of atmospheric air flowing over a flat plate of prescribed length and temperature.

**FIND:** Rate of heat transfer corresponding to  $Re_{x,c} = 10^5$ ,  $5 \times 10^5$  and  $10^6$ .

**SCHEMATIC:**

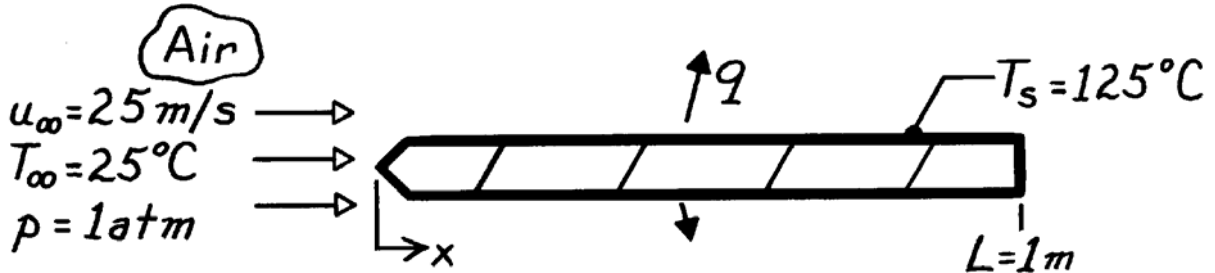

**ASSUMPTIONS:** (1) Flow over top and bottom surfaces.

**PROPERTIES:** Table A-4, Air ( $T_f = 348\text{K}$ , 1 atm):  $\rho = 1.00\text{ kg/m}^3$ ,  $\nu = 20.72 \times 10^{-6}\text{ m}^2/\text{s}$ ,  $k = 0.0299\text{ W/m}\cdot\text{K}$ ,  $Pr = 0.700$ .

**ANALYSIS:** With

$$Re_L = \frac{u_\infty L}{\nu} = \frac{25\text{ m/s} \times 1\text{ m}}{20.72 \times 10^{-6}\text{ m}^2/\text{s}} = 1.21 \times 10^6$$

the flow becomes turbulent for each of the three values of  $Re_{x,c}$ . Hence,

$$\overline{Nu}_L = \left(0.037 Re_L^{4/5} - A\right) Pr^{1/3}$$

$$A = 0.037 Re_{x,c}^{4/5} - 0.664 Re_{x,c}^{1/2}$$

$Re_{x,c}$	$10^5$	$5 \times 10^5$	$10^6$
A	160	871	1671
$\overline{Nu}_L$	2267	1635	926
$\overline{h}_L$ ( $\text{W/m}^2 \cdot \text{K}$ )	67.8	48.9	27.7
$q'$ ( $\text{W/m}$ )	13,560	9780	5530

where  $q' = 2 \overline{h}_L L (T_s - T_\infty)$  is the total heat loss per unit width of plate.

**COMMENTS:** Note that  $\overline{h}_L$  decreases with increasing  $Re_{x,c}$ , as more of the surface becomes covered with a laminar boundary layer.

## PROBLEM 7.11

**KNOWN:** Length of isothermal flat plate in parallel flow,  $L$ .

**FIND:** Expression for the average heat transfer coefficients for  $N$  plates each of length  $L_N = L/N$  to the average coefficient for the single plate.

**SCHEMATIC:**

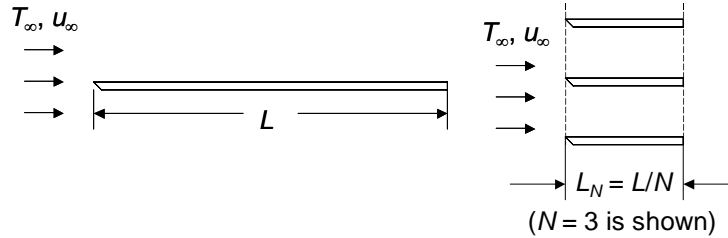

**ASSUMPTIONS:** (1) Laminar flow, (2) Constant properties.

**ANALYSIS:** For the single plate, Equation 7.30 applies

$$\overline{Nu}_L = \frac{\bar{h}_{L,1} L}{k} = 0.664 Re_L^{1/2} Pr^{1/3} \quad \text{or} \quad \bar{h}_{L,1} = (k/L) 0.664 Re_L^{1/2} Pr^{1/3} \quad (1)$$

For the multiple plates,

$$\overline{Nu}_{L,N} = \frac{\bar{h}_{L,N} L_N}{k} = 0.664 Re_{L_N}^{1/2} Pr^{1/3} \quad \text{where} \quad L_N = L/N \quad \text{and} \quad Re_{L_N} = Re_L/N \quad (2a, b, c)$$

Combining Equations 2a, 2b and 2c yields

$$\bar{h}_{L,N} = \frac{kN}{L} 0.664 (Re_L/N)^{1/2} Pr^{1/3} \quad (3)$$

Dividing Equation 3 by Equation 1 yields

$$\bar{h}_{L,N} / \bar{h}_{L,1} = N^{1/2} \quad <$$

**COMMENTS:** (1) By breaking the single plate into shorter segments, the average boundary layer thickness is reduced, resulting in an increase of the average heat transfer coefficient. This is an effective strategy for heat transfer *enhancement*. (2) If the boundary layer over the single plate is not completely laminar, breaking it into shorter segments may or may not result in an increase in the average heat transfer coefficient since the turbulent section of the boundary layer over the single plate may be eliminated. (3) The relationship for completely turbulent flow is  $\bar{h}_{L,N} / \bar{h}_L = N^{1/5}$ , revealing less sensitivity to the plate length than for laminar conditions.

## PROBLEM 7.12

**KNOWN:** Length of isothermal flat plate in parallel flow,  $L$ .

**FIND:** Expression for the average heat transfer coefficients for  $N$  plates each of length  $L_N = L/N$  to the average heat transfer coefficient for the single plate.

**SCHEMATIC:**

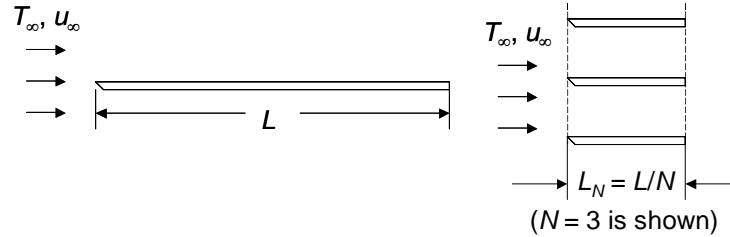

**ASSUMPTIONS:** (1) Turbulent flow, (2) Constant properties.

**ANALYSIS:** Since  $Re_{x,c} = 0$ , Equation 7.39 yields  $A = 0$ . Therefore, for the single plate,

$$\overline{Nu}_L = \frac{\bar{h}_{L,1}L}{k} = 0.036Re_L^{4/5}Pr^{1/3} \quad \text{or} \quad \bar{h}_{L,1} = (k/L)0.036Re_L^{4/5}Pr^{1/3} \quad (1)$$

For the multiple plates,

$$\overline{Nu}_{L,N} = \frac{\bar{h}_{L,N}L_N}{k} = 0.037Re_{L_N}^{4/5}Pr^{1/3} \quad \text{where} \quad L_N = L/N \quad \text{and} \quad Re_{L_N} = Re_L/N \quad (2a, b, c)$$

Combining Equations 2a, 2b and 2c yields

$$\bar{h}_{L,N} = \frac{kN}{L}0.037(Re_L/N)^{4/5}Pr^{1/3} \quad (3)$$

Dividing Equation 3 by Equation 1 yields

$$\bar{h}_{L,N} / \bar{h}_{L,1} = N^{1/5} \quad <$$

**COMMENTS:** (1) By breaking the single plate into shorter segments, the average boundary layer thickness is reduced, resulting in a slight increase of the average heat transfer coefficient. Hence, breaking the plate into shorter lengths results in modest heat transfer *enhancement*. (2) The relationship for laminar flow is  $\bar{h}_{L,N} / \bar{h}_L = N^{1/2}$ , revealing more sensitivity to the plate length for laminar conditions.

### PROBLEM 7.13

**KNOWN:** Dimensions and surface temperatures of a flat plate. Velocity and temperature of air and water flow parallel to the plate.

**FIND:** (a) Average convective heat transfer coefficient, convective heat transfer rate, and drag force when  $L = 2$  m,  $w = 2$  m. (b) Average convective heat transfer coefficient, convective heat transfer rate, and drag force when  $L = 0.1$  m,  $w = 0.1$  m.

**SCHEMATIC:**

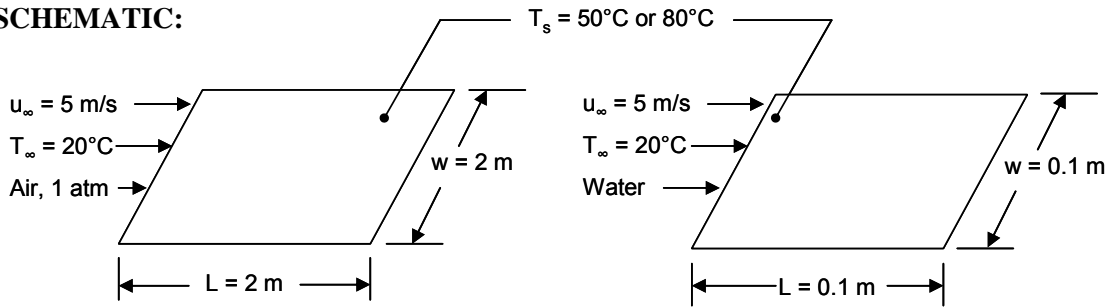

(a) Air

(b) Water

**ASSUMPTIONS:** (1) Steady-state conditions, (2) Boundary layer assumptions are valid, (3) Constant properties, (4) Transition Reynolds number is  $5 \times 10^5$ .

**PROPERTIES:** Using *IHT*, Air ( $p = 1$  atm,  $T_f = 35^\circ\text{C} = 308$  K):  $Pr = 0.706$ ,  $k = 26.9 \times 10^{-3}$  W/m·K,  $\nu = 1.669 \times 10^{-5}$  m<sup>2</sup>/s,  $\rho = 1.135$  kg/m<sup>3</sup>. Air ( $p = 1$  atm,  $T_f = 50^\circ\text{C} = 323$  K):  $Pr = 0.704$ ,  $k = 28.0 \times 10^{-3}$  W/m·K,  $\nu = 1.82 \times 10^{-5}$  m<sup>2</sup>/s,  $\rho = 1.085$  kg/m<sup>3</sup>. Water ( $T_f = 308$  K):  $Pr = 4.85$ ,  $k = 0.625$  W/m·K,  $\nu = 7.291 \times 10^{-7}$  m<sup>2</sup>/s,  $\rho = 994$  kg/m<sup>3</sup>. Water ( $T_f = 323$  K):  $Pr = 3.56$ ,  $k = 0.643$  W/m·K,  $\nu = 5.543 \times 10^{-7}$  m<sup>2</sup>/s,  $\rho = 988$  kg/m<sup>3</sup>.

**ANALYSIS:**

(a) We begin by calculating the Reynolds numbers for the two different surface temperatures:

$$Re_{L1} = \frac{u_\infty L}{\nu_1} = \frac{5 \text{ m/s} \times 2 \text{ m}}{1.669 \times 10^{-5} \text{ m}^2/\text{s}} = 5.99 \times 10^5$$

$$Re_{L2} = \frac{u_\infty L}{\nu_2} = \frac{5 \text{ m/s} \times 2 \text{ m}}{1.82 \times 10^{-5} \text{ m}^2/\text{s}} = 5.49 \times 10^5$$

Therefore, in both cases the flow is turbulent at the end of the plate and the conditions in the boundary layer are “mixed.”

The average drag coefficient can be calculated from Equation 7.40. For the first case,

$$\begin{aligned} \bar{C}_{f,L1} &= 0.074 Re_{L1}^{-1/5} - 1742 Re_{L1}^{-1} \\ &= 0.074(5.99 \times 10^5)^{-1/5} - 1742(5.99 \times 10^5)^{-1} = 2.27 \times 10^{-3} \end{aligned}$$

Then

$$\begin{aligned} F_{D1} &= \bar{C}_{f,L1} \frac{1}{2} \rho u_\infty^2 A_s \\ &= 2.27 \times 10^{-3} \times \frac{1}{2} \times 1.135 \text{ kg/m}^3 \times (5 \text{ m/s})^2 \times 8 \text{ m}^2 = 0.257 \text{ N} \\ &= 0.257 \text{ N} \end{aligned}$$

<

Continued...

### PROBLEM 7.13 (Cont.)

The average Nusselt number is calculated from Equation 7.38, with  $A = 871$  for a transition Reynolds number of  $5 \times 10^5$ .

$$\begin{aligned}\overline{Nu}_{L1} &= (0.037 Re_L^{4/5} - 871) Pr^{1/3} \\ &= \left[ 0.037(5.99 \times 10^5)^{4/5} - 871 \right] (0.706)^{1/3} = 604.\end{aligned}$$

Then

$$\overline{h}_{L1} = \overline{Nu}_{L1} k / L = 604 \times 26.9 \times 10^{-3} \text{ W/m} \cdot \text{K} / 2 \text{ m} = 8.13 \text{ W/m}^2 \cdot \text{K} \quad <$$

and

$$q_1 = \overline{h}_{L1} A_s (T_s - T_\infty) = 8.13 \text{ W/m}^2 \cdot \text{K} \times 8 \text{ m}^2 \times (50^\circ\text{C} - 20^\circ\text{C}) = 1950 \text{ W} \quad <$$

Similarly for  $T_s = 80^\circ\text{C}$  we find

$$F_{D2} = 0.227 \text{ N}, \quad \overline{h}_{L2} = 7.16 \text{ W/m}^2 \cdot \text{K}, \quad q_2 = 3440 \text{ W} \quad <$$

(b) Repeating the calculations for water

$$Re_{L1} = \frac{u_\infty L}{\nu} = \frac{5 \text{ m/s} \times 0.1 \text{ m}}{7.291 \times 10^{-7} \text{ m}^2/\text{s}} = 6.86 \times 10^5$$

$$Re_{L2} = 9.02 \times 10^5$$

The flow is turbulent at the end of the plate in both cases.

$$\overline{C}_{f,L1} = 0.074(6.86 \times 10^5)^{-1/5} - 1742(6.86 \times 10^5)^{-1} = 2.49 \times 10^{-3}$$

$$F_{D1} = 2.49 \times 10^{-3} \times 1/2 \times 994 \text{ kg/m}^3 \times (5 \text{ m/s})^2 \times 0.02 \text{ m}^2 = 0.620 \text{ N} \quad <$$

$$\overline{Nu}_L = \left[ 0.037(6.86 \times 10^5)^{4/5} - 871 \right] (4.85)^{1/3} = 1450$$

$$\overline{h}_{L1} = 1450 \times 0.625 \text{ W/m} \cdot \text{K} / 0.1 \text{ m} = 9050 \text{ W/m}^2 \cdot \text{K} \quad <$$

$$q_1 = 9050 \text{ W/m}^2 \cdot \text{K} \times 0.02 \text{ m}^2 \times (50^\circ\text{C} - 20^\circ\text{C}) = 5430 \text{ W} \quad <$$

For the higher surface temperature,

$$F_{D2} = 0.700 \text{ N}, \quad \overline{h}_{L2} = 12,600 \text{ W/m}^2 \cdot \text{K}, \quad q_2 = 15,100 \text{ W} \quad <$$

**COMMENTS:** (1) For air, kinematic viscosity increases with increasing temperature. This decreases the Reynolds number which causes the transition to turbulence to move downstream, thereby decreasing the drag force and average heat transfer coefficient. The heat transfer rate increases for the higher surface temperature, however, because of the greater temperature difference between the surface and air. (2) For water, kinematic viscosity decreases with increasing temperature, causing the opposite trends as for air. The heat transfer rate increases dramatically for the higher surface temperature because of the increases in both the heat transfer coefficient and temperature difference. (3) Even though the water flows over a plate that is 400 times smaller, the drag force and heat transfer rate are larger than for air because of the smaller viscosity and greater density, thermal conductivity, and Prandtl number. The discrepancy is particularly great for the heat transfer rate. (4) The problem highlights the importance of carefully accounting for the temperature dependence of thermal properties.

## PROBLEM 7.14

**KNOWN:** Velocity and temperature of water in parallel flow over a flat plate of 1-m length.

**FIND:** (a) Calculate and plot the variation of the local convection coefficient,  $h_x(x)$ , with distance for flow conditions corresponding to transition Reynolds numbers of  $5 \times 10^5$ ,  $3 \times 10^5$  and 0 (fully turbulent), (b) Plot the variation of the average convection coefficient,  $\bar{h}_x(x)$ , for the three flow conditions of part (a), and (c) Determine the average convection coefficients for the entire plate,  $\bar{h}_L$ , for the three flow conditions of part (a).

**SCHEMATIC:**

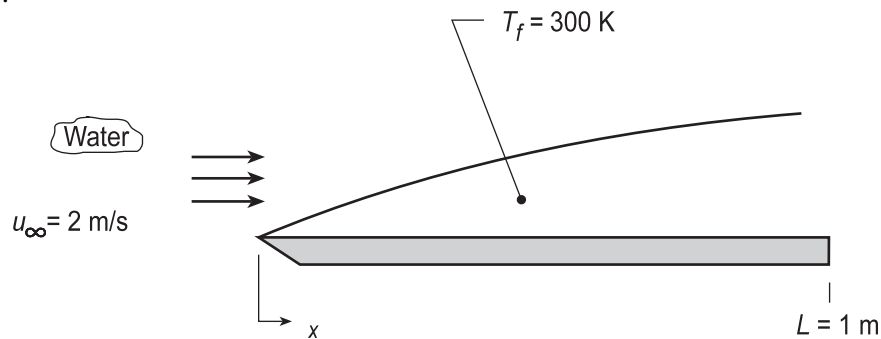

**ASSUMPTIONS:** (1) Steady-state conditions, (2) Constant surface temperature, and (3) Critical Reynolds depends upon prescribed flow conditions.

**PROPERTIES:** Table A.6, Water (300 K):  $\rho = 997 \text{ kg/m}^3$ ,  $\mu = 855 \times 10^{-6} \text{ N}\cdot\text{s/m}^2$ ,  $\nu = \mu/\rho = 0.858 \times 10^{-6} \text{ m}^2/\text{s}$ ,  $k = 0.613 \text{ W/m}\cdot\text{K}$ ,  $\text{Pr} = 583$ .

**ANALYSIS:** (a) The Reynolds number for the plate ( $L = 1 \text{ m}$ ) is

$$\text{Re}_L = \frac{u_\infty L}{\nu} = \frac{2 \text{ m/s} \times 1 \text{ m}}{0.858 \times 10^{-6} \text{ m}^2/\text{s}} = 2.33 \times 10^6.$$

and the boundary layer is mixed with  $\text{Re}_{x,c} = 5 \times 10^5$ ,

$$x_c = L \left( \text{Re}_{x,c} / \text{Re}_L \right) = 1 \text{ m} \frac{5 \times 10^5}{2.33 \times 10^6} = 0.215 \text{ m}$$

Using the *IHT Correlation Tool, External Flow, Local coefficients for Laminar or Turbulent Flow*,  $h_x(x)$  was evaluated and plotted with critical Reynolds numbers of  $5 \times 10^5$ ,  $3.0 \times 10^5$  and 0 (fully turbulent). Note the location of the laminar-turbulent transition for the first two flow conditions.

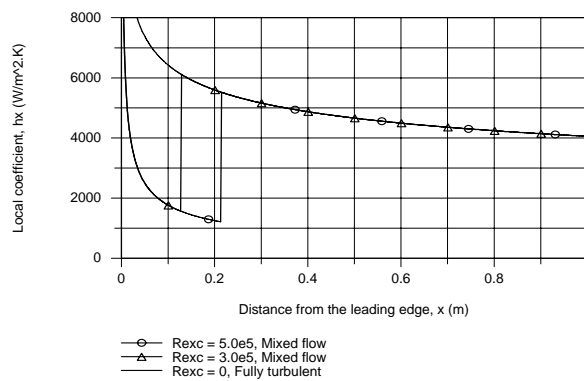

Continued...

## PROBLEM 7.14 (Cont.)

(b) Using the *IHT Correlation Tool, External Flow, Average coefficient for Laminar or Mixed Flow*,  $\bar{h}_x(x)$  was evaluated and plotted for the three flow conditions. Note that the change in  $\bar{h}_x(x)$  at the critical length,  $x_c$ , is rather gradual, compared to the abrupt change for the local coefficient,  $h_x(x)$ .

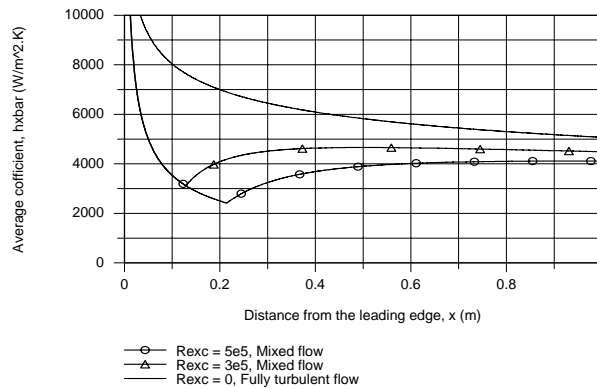

(c) The average convection coefficients for the plate can be determined from the above plot since  $\bar{h}_L = \bar{h}_x(L)$ . The values for the three flow conditions are

$$\bar{h}_L = 4110, 4490 \text{ and } 5072 \text{ W/m}^2 \cdot \text{K}$$

**COMMENTS:** A copy of the *IHT Workspace* used to generate the above plot is shown below.

**/\* Method of Solution:** Use the Correlation Tools, External Flow, Flat Plate, for (i) Local, laminar or turbulent flow and (ii) Average, laminar or mixed flow, to evaluate the local and average convection coefficients as a function of position on the plate. In each of these tools, the value of the critical Reynolds number,  $R_{ex,c}$ , can be set corresponding to the special flow conditions. \*/

**// Correlation Tool: External Flow, Plate Plate, Local, laminar or turbulent flow.**

$Nu_x = Nu_{x,EF\_FP\_LT}(Re_x, Re_{x,c}, Pr)$  // Eq 7.23,36

$Nu_x = h_x * x / k$

$Re_x = u_{inf} * x / \nu$

$Re_{x,c} = 1e-10$

// Evaluate properties at the film temperature,  $T_f$ .

//  $T_f = (T_{inf} + T_s) / 2$

/\* Correlation description: Parallel external flow (EF) over a flat plate (FP), local coefficient; laminar flow (L) for  $Re_x < Re_{x,c}$ , Eq 7.23; turbulent flow (T) for  $Re_x > Re_{x,c}$ , Eq 7.36;  $0.6 \leq Pr \leq 60$ . See Table 7.9. \*/

**// Correlation Tool: External Flow, Plate Plate, Average, laminar or mixed flow.**

$Nu_{Lbar} = Nu_{Lbar,EF\_FP\_LM}(Re_x, Re_{x,c}, Pr)$  // Eq 7.30, 7.38, 7.39

$Nu_{Lbar} = h_{Lbar} * x / k$

// Changed variable from L to x

//  $Re_L = u_{inf} * x / \nu$

//  $Re_{x,c} = 5.0E5$

/\* Correlation description: Parallel external flow (EF) over a flat plate (FP), average coefficient; laminar (L) if  $Re_L < Re_{x,c}$ , Eq 7.30; mixed (M) if  $Re_L > Re_{x,c}$ , Eq 7.38 and 7.39;  $0.6 \leq Pr \leq 60$ . See Table 7.9. \*/

**// Properties Tool - Water:**

// Water property functions :T dependence, From Table A.6

// Units: T(K), p(bars);

$x_f = 0$

// Quality (0=sat liquid or 1=sat vapor); "x" is used as spatial coordinate

$p = psat\_T(\text{"Water"}, T_f)$

// Saturation pressure, bar

$\nu = \nu_{Tx}(\text{"Water"}, T_f, x)$

// Kinematic viscosity, m<sup>2</sup>/s

$k = k_{Tx}(\text{"Water"}, T_f, x)$

// Thermal conductivity, W/m·K

$Pr = Pr_{Tx}(\text{"Water"}, T_f, x)$

// Prandtl number

**// Assigned Variables:**

$x = 1$

// Distance from leading edge;  $0 \leq x \leq 1$  m

$u_{inf} = 2$

// Freestream velocity, m/s

$T_f = 300$

// Film temperature, K



### PROBLEM 7.15

**KNOWN:** Two plates of length  $L$  and  $2L$  experience parallel flow with a critical Reynolds number of  $5 \times 10^5$ .

**FIND:** Reynolds numbers for which the total heat transfer rate is independent of orientation.

**SCHEMATIC:**

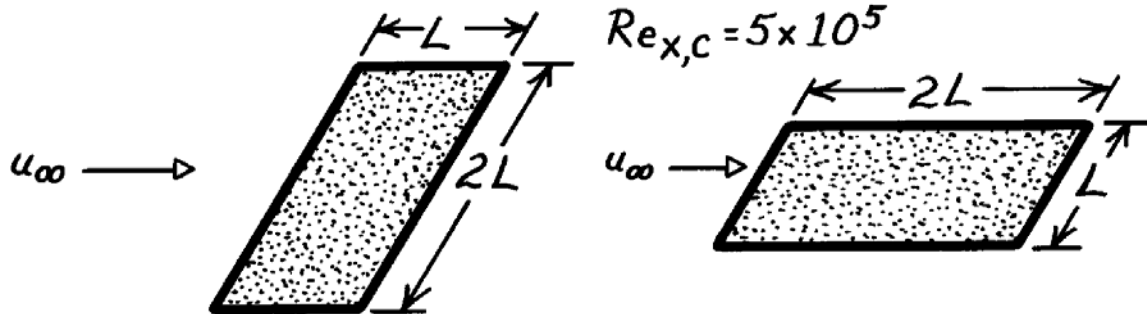

**ASSUMPTIONS:** (1) Plate temperatures and flow conditions are equivalent.

**ANALYSIS:** The total heat transfer rate would be the same ( $q_L = q_{2L}$ ), if the convection coefficients were equal,  $\bar{h}_L = \bar{h}_{2L}$ . Conditions for which such an equality is possible may be inferred from a sketch of  $\bar{h}_L$  versus  $Re_L$ .

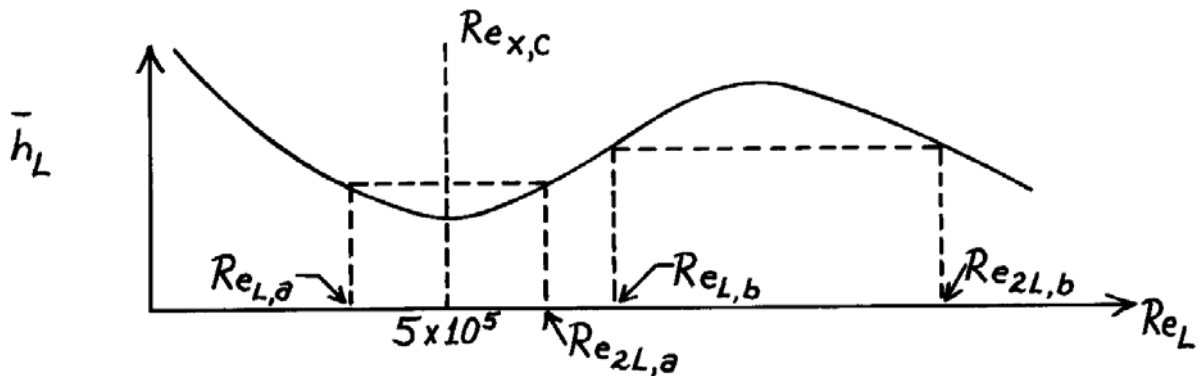

For laminar flow ( $Re_L < Re_{x,c}$ ),  $\bar{h}_L \propto L^{-1/2}$ , and for mixed laminar and turbulent flow ( $Re_L > Re_{x,c}$ ),  $\bar{h}_L = C_1 L^{-1/5} - C_2 L^{-1}$ . Hence  $\bar{h}_L$  varies with  $Re_L$  as shown, and two possibilities are suggested.

*Case (a):* Laminar flow exists on the shorter plate, while mixed flow conditions exist on the longer plate.

*Case (b):* Mixed boundary layer conditions exist on both plates.

In both cases, it is required that

$$\bar{h}_L = \bar{h}_{2L} \quad \text{and} \quad Re_{2L} = 2 Re_L.$$

Continued ...

### PROBLEM 7.15 (Cont.)

Case (a): From expressions for  $\bar{h}_L$  in laminar and mixed flow

$$0.664 \frac{k}{L} \text{Re}_L^{1/2} \text{Pr}^{1/3} = \frac{k}{2L} (0.037 \text{Re}_{2L}^{4/5} - 871) \text{Pr}^{1/3}$$
$$0.664 \text{Re}_L^{1/2} = 0.032 \text{Re}_L^{4/5} - 435.$$

Since  $\text{Re}_L < 5 \times 10^5$  and  $\text{Re}_{2L} = 2 \text{Re}_L > 5 \times 10^5$ , the required value of  $\text{Re}_L$  may be narrowed to the range

$$2.5 \times 10^5 < \text{Re}_L < 5 \times 10^5.$$

From a trial-and-error solution, it follows that

$$\text{Re}_L \approx 3.2 \times 10^5. \quad <$$

Case (b): For mixed flow on both plates

$$\frac{k}{L} (0.037 \text{Re}_L^{4/5} - 871) \text{Pr}^{1/3} = \frac{k}{2L} (0.037 \text{Re}_{2L}^{4/5} - 871) \text{Pr}^{1/3}$$

or

$$0.037 \text{Re}_L^{4/5} - 871 = 0.032 \text{Re}_L^{4/5} - 435$$
$$0.005 \text{Re}_L^{4/5} = 436$$

$$\text{Re}_L \approx 1.50 \times 10^6. \quad <$$

**COMMENTS:** (1) Note that it is impossible to satisfy the requirement that  $\bar{h}_L = \bar{h}_{2L}$  if  $\text{Re}_L < 0.25 \times 10^5$  (laminar flow for both plates).

(2) The results are independent of the nature of the fluid.

## PROBLEM 7.16

**KNOWN:** Dimensions of and heat generation rate in thin membrane. Velocity and temperature of air flow parallel to membrane. Air streams above and below membrane are in same, opposite, or orthogonal directions.

**FIND:** (a) Minimum and maximum local membrane temperatures. Flow configuration that minimizes the membrane temperature. (b) Plot the surface temperature distribution for flow in the same and opposite directions. Find configuration that minimizes spatial temperature gradients.

**SCHEMATIC:**

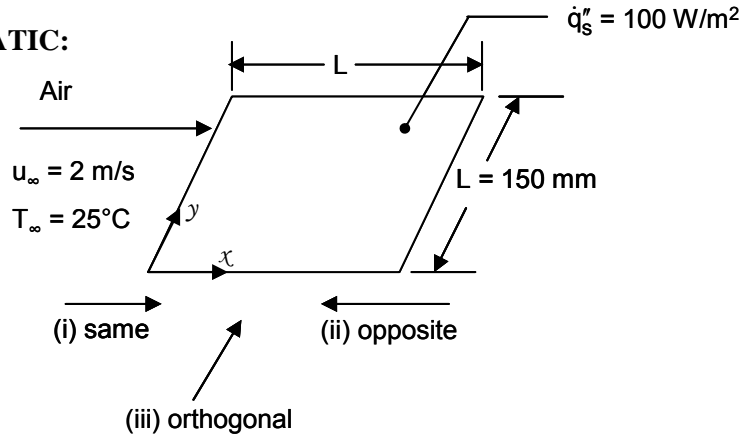

**ASSUMPTIONS:** (1) Steady-state conditions, (2) Boundary layer assumptions hold, (3) Constant properties, (4) Solutions are bounded by constant surface temperature and constant heat flux cases for the opposite and orthogonal flow configurations.

**PROPERTIES:** Table A-4, Air ( $T_f \approx 323$  K):  $\nu = 18.20 \times 10^{-6} \text{ m}^2/\text{s}$ ,  $k = 0.0280 \text{ W/m}\cdot\text{K}$ ,  $\text{Pr} = 0.704$ .

**ANALYSIS:**

(a) We begin by calculating the Reynolds number

$$\text{Re}_L = \frac{u_\infty L}{\nu} = \frac{2 \text{ m/s} \times 0.15 \text{ m}}{18.20 \times 10^{-6} \text{ m}^2/\text{s}} = 1.65 \times 10^4$$

Therefore, the flow is laminar.

(a) Top and bottom flows in same direction.

By symmetry, the heat flux from the membrane to the air is  $50 \text{ W/m}^2$  everywhere for the top and bottom air flows. Since the heat flux is uniform, the local Nusselt number is given by Equation 7.45,

$$\text{Nu}_x = 0.453 \text{Re}_x^{1/2} \text{Pr}^{1/3}$$

Thus  $h_x = c_q x^{-1/2}$

where

$$\begin{aligned} c_q &= 0.453(u_\infty/\nu)^{1/2} \text{Pr}^{1/3} k \\ &= 0.453(2 \text{ m/s}/18.2 \times 10^{-6} \text{ m}^2/\text{s})^{1/2} \times (0.704)^{1/3} \times 0.028 \text{ W/m}\cdot\text{K} = 3.74 \text{ W/m}^{3/2} \cdot \text{K} \end{aligned}$$

Then  $q_s'' = h_x(T_s - T_\infty)$  and  $T_s - T_\infty = \frac{q_s''}{h_x} = \frac{q_s''}{c_q} x^{1/2}$  (1)

Continued...

### PROBLEM 7.16 (Cont.)

Clearly the minimum temperature occurs at  $x = 0$  and is

$$T_{\min} = T_{\infty} = 25^{\circ}\text{C} \quad <$$

The maximum temperature occurs at  $x = L$  and is

$$T_{\max} = 25^{\circ}\text{C} + 50 \text{ W/m}^2 \times (0.15 \text{ m})^{1/2} / 3.74 \text{ W/m}^{3/2} \cdot \text{K} = 30.2^{\circ}\text{C} \quad <$$

(ii) Top and bottom flows in opposite direction.

The heat flux entering each of the top and bottom flows will no longer be uniform. Near  $x = 0$ , where the top flow first encounters the plate, the heat transfer coefficient on the top surface is theoretically infinite, and all the generated heat will enter the top flow. The opposite situation will occur at  $x = L$ .

We bound the solution by considering Nusselt number correlations for uniform surface temperature and uniform surface heat flux, Equations 7.23 and 7.45. In both cases, the heat transfer coefficient varies as  $x^{-1/2}$ , where  $x$  is the distance from the leading edge, thus for the top and bottom,

$$h_{x,t} = cx^{-1/2}, \quad h_{x,b} = c(L-x)^{-1/2}$$

And all of the generated heat is removed by the top and bottom flows:

$$\dot{q}'' = (h_{x,t} + h_{x,b})(T_s - T_{\infty})$$

$$\text{Thus } T_s - T_{\infty} = \frac{\dot{q}''}{h_{x,t} + h_{x,b}} = \frac{\dot{q}''}{c[x^{-1/2} + (L-x)^{-1/2}]} \quad (2)$$

The minimum temperature occurs at  $x = 0$  or  $x = L$ , and is

$$T_{\min} = T_{\infty} = 25^{\circ}\text{C} \quad <$$

The maximum temperature occurs where the denominator is minimum:

$$\frac{d}{dx} [x^{-1/2} + (L-x)^{-1/2}] = 0$$

$$-\frac{1}{2}x^{-3/2} + \frac{1}{2}(L-x)^{-3/2} = 0$$

$$x = L - x$$

$$x = L/2$$

At that location

$$T_{\max} = T_{\infty} + \frac{\dot{q}''}{c2(L/2)^{-1/2}}$$

For uniform surface temperature,

$$c_T = 0.332(u_{\infty}/\nu)^{1/2} \text{Pr}^{1/3} k$$

$$= 0.332(2 \text{ m/s}/18.2 \times 10^{-6} \text{ m}^2/\text{s})^{1/2} \times (0.704)^{1/3} \times 0.0280 \text{ W/m} \cdot \text{K} = 2.74 \text{ W/m}^{3/2} \cdot \text{K}$$

$$\text{And } T_{\max} = 25^{\circ}\text{C} + \frac{100 \text{ W/m}^2}{2.74 \text{ W/m}^{3/2} \cdot \text{K} \times 2 \times (0.15 \text{ m}/2)^{-1/2}} = 30.0^{\circ}\text{C}$$

Continued...

### PROBLEM 7.16 (Cont.)

For uniform surface heat flux, we previously found  $c_q = 3.74 \text{ W/m}^{3/2}\cdot\text{K}$ , thus,  $T_{\max} = 28.7^\circ\text{C}$ .

Therefore, for the opposite flow case,  $28.7^\circ\text{C} \leq T_{\max} \leq 30.0^\circ\text{C}$

(iii) Top and bottom flows in orthogonal directions.

Here the heat transfer coefficients are given by

$$h_{x,t} = cx^{-1/2}, \quad h_{y,b} = cy^{-1/2}$$

And  $\dot{q}'' = c(x^{-1/2} + y^{-1/2})(T_s - T_\infty)$

$$\text{So } T_s - T_\infty = \frac{\dot{q}''}{c(x^{-1/2} + y^{-1/2})}$$

The temperature will be minimum along  $x = 0$  or  $y = 0$ , where

$$T_{\min} = T_\infty = 25^\circ\text{C}$$

The temperature will be maximum along  $x = y = L$ , where

$$T_{\max} = T_\infty + \frac{\dot{q}''}{c \cdot 2 L^{-1/2}}$$

The values of  $c$  are the same as previously, therefore we find  $30.2^\circ\text{C} \leq T_{\max} \leq 32.1^\circ\text{C}$

The surface temperature is minimized when the air streams are in opposite directions, because a small heat transfer coefficient on the top is paired with a large heat transfer coefficient on the bottom, and vice versa.

(b) *IHT* was used to plot Equation (1) and (2) for  $c = c_T$  or  $c_q$ . The result is shown below.

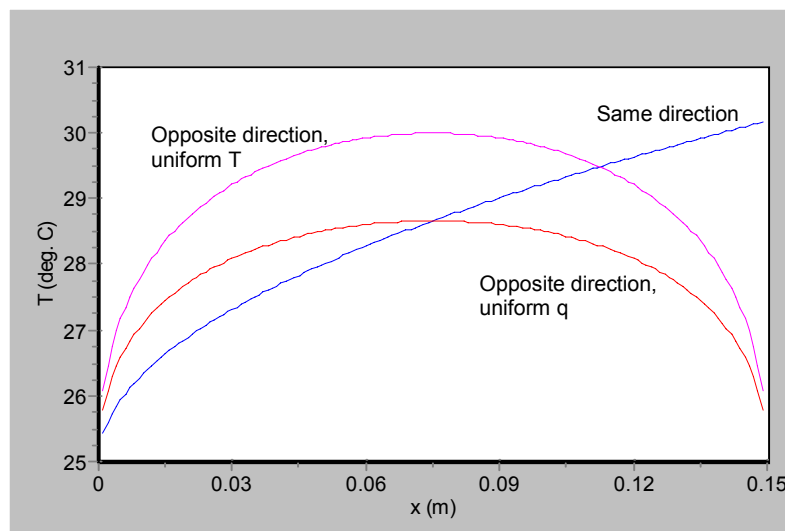

The spatial temperature gradients are somewhat less for the opposite flow case.

**COMMENTS:** To correctly treat the convective heat transfer would require a coupled numerical solution of the thermal energy equation for both boundary layers simultaneously.

### PROBLEM 7.17

**KNOWN:** Temperature, pressure and Reynolds number for air flow over a flat plate of uniform surface temperature.

**FIND:** (a) Rate of heat transfer from the plate, (b) Rate of heat transfer if air velocity is doubled and pressure is increased to 10 atm.

**SCHEMATIC:**

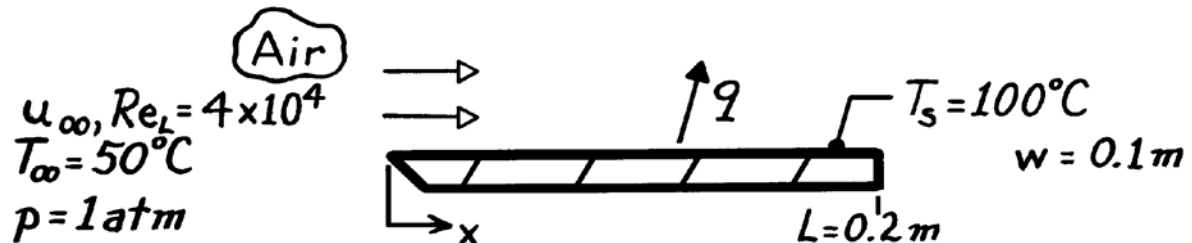

**ASSUMPTIONS:** (1) Steady-state conditions, (2) Uniform surface temperature, (3) Negligible radiation, (4)  $Re_{x_c} = 5 \times 10^5$ .

**PROPERTIES:** Table A-4, Air ( $T_f = 348\text{K}$ , 1 atm):  $k = 0.0299 \text{ W/m}\cdot\text{K}$ ,  $Pr = 0.70$ .

**ANALYSIS:** (a) The heat rate is

$$q = \bar{h}_L (w \times L) (T_s - T_\infty).$$

Since the flow is laminar over the entire plate for  $Re_L = 4 \times 10^4$ , it follows that

$$\overline{Nu}_L = \frac{\bar{h}_L L}{k} = 0.664 Re_L^{1/2} Pr^{1/3} = 0.664 (40,000)^{1/2} (0.70)^{1/3} = 117.9.$$

Hence 
$$\bar{h}_L = 117.9 \frac{k}{L} = 117.9 \frac{0.0299 \text{ W/m}\cdot\text{K}}{0.2 \text{ m}} = 17.6 \text{ W/m}^2 \cdot \text{K}$$

and 
$$q = 17.6 \frac{\text{W}}{\text{m}^2 \cdot \text{K}} (0.1 \text{ m} \times 0.2 \text{ m}) (100 - 50)^\circ \text{C} = 17.6 \text{ W.} \quad <$$

(b) With  $p_2 = 10 p_1$ , it follows that  $\rho_2 = 10 \rho_1$  and  $v_2 = v_1/10$ . Hence

$$Re_{L,2} = \left( \frac{u_\infty L}{\nu} \right)_2 = 2 \times 10 \left( \frac{u_\infty L}{\nu} \right)_1 = 20 Re_{L,1} = 8 \times 10^5$$

and mixed boundary layer conditions exist on the plate. Hence

$$\overline{Nu}_L = \frac{\bar{h}_L L}{k} = \left( 0.037 Re_L^{4/5} - 871 \right) Pr^{1/3} = \left[ 0.037 \times (8 \times 10^5)^{4/5} - 871 \right] (0.70)^{1/3}$$

$$\overline{Nu}_L = 961.$$

Hence, 
$$\bar{h}_L = 961 \frac{0.0299 \text{ W/m}\cdot\text{K}}{0.2 \text{ m}} = 143.6 \text{ W/m}^2 \cdot \text{K}$$

$$q = 143.6 \frac{\text{W}}{\text{m}^2 \cdot \text{K}} (0.1 \text{ m} \times 0.2 \text{ m}) (100 - 50)^\circ \text{C} = 143.6 \text{ W.} \quad <$$

**COMMENTS:** Note that, in calculating  $Re_{L,2}$ , ideal gas behavior has been assumed. It has also been assumed that  $k$ ,  $\mu$  and  $Pr$  are independent of pressure over the range considered.

## PROBLEM 7.18

**KNOWN:** Solar cell material dimensions and properties, solar-to-electrical conversion efficiency dependence on silicon temperature, solar irradiation and location where the irradiation is absorbed, air velocity and temperature.

**FIND:** (a) Electrical power produced and silicon temperature for a  $L = 1$  m long,  $w = 0.1$  m wide solar cell with  $G = 700$   $\text{W/m}^2$  with tripped boundary layer, (b) Same as Part (a) but with  $L = 0.1$  m,  $w = 1$  m, (c) Plot of the electrical power produced and the silicon temperature for air velocities in the range  $0 \leq u_m \leq 10$  m/s for the  $L = 0.1$  m configuration.

**SCHEMATIC:**

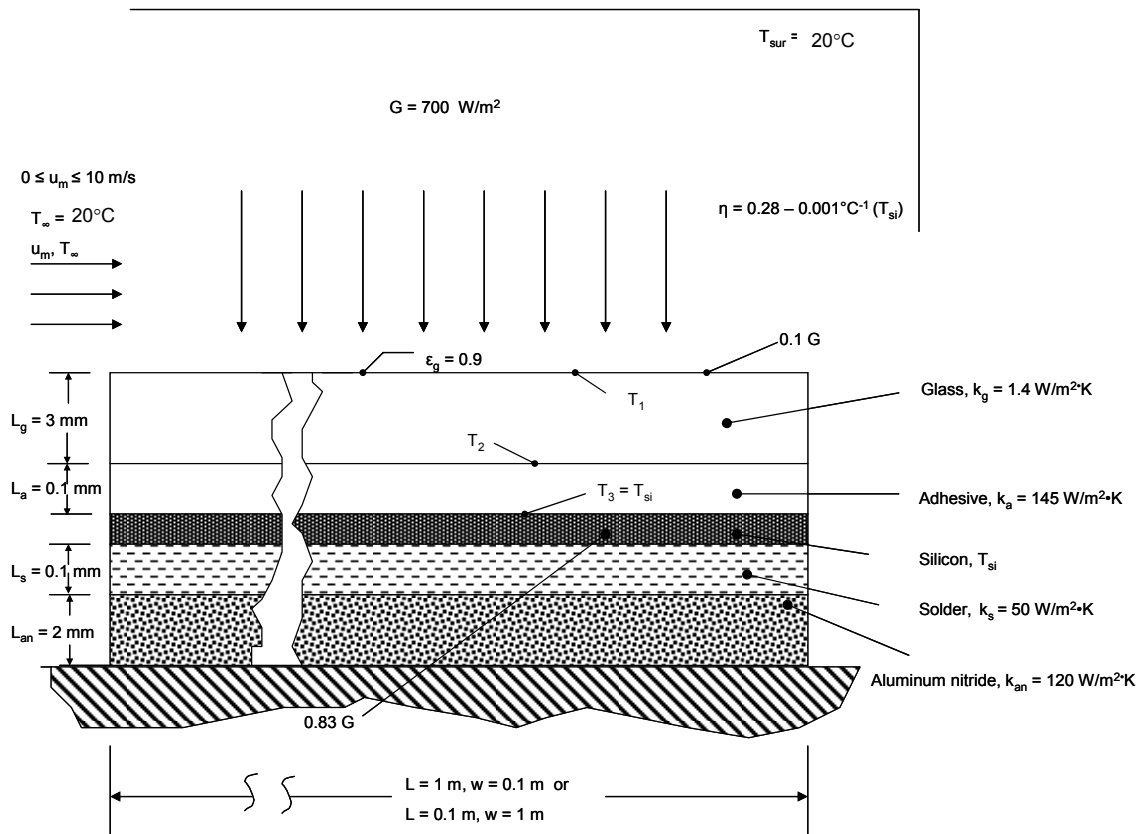

**ASSUMPTIONS:** (1) Steady-state conditions, (2) Constant properties, (3) One-dimensional heat transfer, (4) Tripped and turbulent boundary layer, (5) Large surroundings, (6) Negligible contact resistances.

**PROPERTIES:** Table A.4, air (assume  $T_f = 308$  K,  $p = 1$  atm):  $k = 0.0269$   $\text{W/m}\cdot\text{K}$ ,  $\nu = 1.669 \times 10^{-5}$   $\text{m}^2/\text{s}$ ,  $\text{Pr} = 0.706$ .

**ANALYSIS:**

(a) We begin by drawing the thermal circuit for the problem, recognizing that there is no heat transfer downward from the thin silicon layer.

Continued...

**PROBLEM 7.18 (Cont.)**

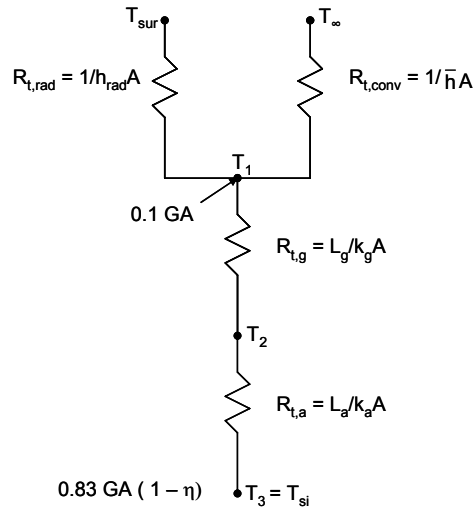

The thermal resistances are

$$R_{t,g} = L_g/k_gA = 3 \times 10^{-3} \text{ m}/(1.4 \text{ W/m} \cdot \text{K} \times 1 \text{ m} \times 0.1 \text{ m}) = 21.43 \times 10^{-3} \text{ K/W}$$

$$R_{t,a} = L_a/k_aA = 0.1 \times 10^{-3} \text{ m}/(145 \text{ W/m} \cdot \text{K} \times 1 \text{ m} \times 0.1 \text{ m}) = 6.897 \times 10^{-6} \text{ K/W}$$

$$h_{\text{rad}} = \varepsilon_g \sigma (T_1 + T_{\text{sur}})(T_1^2 + T_{\text{sur}}^2)$$

$$R_{t,\text{rad}} = \frac{1}{0.9 \times 5.67 \times 10^{-8} \text{ W/m}^2 \cdot \text{K}^4 \times (T_1 + 295 \text{ K}) \times (T_1^2 + (295 \text{ K})^2) \times 1 \text{ m} \times 0.1 \text{ m}} \quad (1)$$

For the tripped boundary layer,

$$\text{Re}_L = \frac{u_m L}{\nu} = \frac{4 \text{ m/s} \times 1 \text{ m}}{1.669 \times 10^{-5} \text{ m}^2/\text{s}} = 239.7 \times 10^3$$

From Equation 7.38

$$\overline{\text{Nu}}_L = 0.037 \text{Re}_L^{4/5} \text{Pr}^{1/3} = 0.037 \times [239.7 \times 10^3]^{0.8} \times 0.706^{1/3} = 662.8$$

$$\bar{h} = \overline{\text{Nu}}_L k/L = 662.8 \times 0.0269 \text{ W/m} \cdot \text{K}/1 \text{ m} = 17.82 \text{ W/m}^2 \cdot \text{K}$$

$$R_{t,\text{conv}} = 1/\bar{h}A = \frac{1}{17.82 \text{ W/m}^2 \cdot \text{K} \times 1 \text{ m} \times 0.1 \text{ m}} = 561.2 \times 10^{-3} \text{ K/W}$$

From the thermal circuit,

$$0.83 \text{ GA} (1 - \eta) = (T_3 - T_1)/(R_{t,g} + R_{t,a}) \quad \text{or} \quad T_3 - T_1 = (R_{t,g} + R_{t,a}) 0.83 \text{ GA} (1 - \eta)$$

$$T_3 - T_1 = (21.43 \times 10^{-3} \text{ K/W} + 6.897 \times 10^{-6} \text{ K/W}) \times 0.83 \times 700 \text{ W/m}^2 \times 1 \text{ m} \times 0.1 \text{ m} \times (1 - \eta)$$

$$T_3 - T_1 = 1.245(1 - \eta) \quad (2)$$

We also note from the thermal circuit,

Continued...



**PROBLEM 7.18 (Cont.)**

$$0.83GA(1 - \eta) + 0.1G = (T_1 - T_{\text{sur}})/R_{t,\text{rad}} + (T_1 - T_{\infty})/R_{t,\text{conv}}$$

Since  $T_{\infty} = T_{\text{sur}}$

$$0.83GA(1 - \eta) + 0.1G = (T_1 - T_{\text{sur}}) \left[ \frac{1}{R_{t,\text{rad}}} + \frac{1}{R_{t,\text{conv}}} \right]$$

$$T_1 - T_{\text{sur}} = \frac{0.83GA(1 - \eta) + 0.1GA}{\left[ \frac{1}{R_{t,\text{rad}}} + \frac{1}{R_{t,\text{conv}}} \right]}$$

$$T_1 - T_{\text{sur}} = \frac{0.83 \times 700 \text{ W/m}^2 \times 1 \text{ m} \times 0.1 \text{ m} \times (1 - \eta) + 0.1 \times 700 \text{ W/m}^2 \times 1 \text{ m} \times 0.1 \text{ m}}{\left[ \frac{1}{R_{t,\text{rad}}} + 1.7819 \text{ W/K} \right]}$$

$$T_1 - T_{\text{sur}} = \frac{58.1 \text{ W} (1 - \eta) + 7 \text{ W}}{\left[ \frac{1}{R_{t,\text{rad}}} + 1.7819 \text{ W/K} \right]} \quad (3)$$

$$\text{where } \eta = 0.28 - 0.001^\circ\text{C}^{-1} \times (T_3 - 273)^\circ\text{C} \quad (4)$$

Equations (1) – (4) may be solved simultaneously to yield

$$\eta = 0.2353, T_3 = T_{\text{si}} = 44.7^\circ\text{C}, T_1 = 43.7^\circ\text{C}, R_{t,\text{rad}} = 1.71 \text{ K/W} \quad <$$

$$\text{The electric power is } P = 0.83GA\eta = 0.83 \times 700 \text{ W/m}^2 \times 1 \text{ m} \times 0.1 \text{ m} \times 0.2353 = 13.67 \text{ W} \quad <$$

(b) For the tripped boundary layer

$$\text{Re}_L = \frac{u_m L}{\nu} = \frac{4/\text{ms} \times 0.1 \text{ m}}{1.669 \times 10^{-5} \text{ m}^2/\text{s}} = 239.7 \times 10^2$$

From Equation 7.38

$$\overline{\text{Nu}}_L = 0.037 \text{Re}^{4/5} \text{Pr}^{1/3} = 0.037 \times \left[ 239.7 \times 10^2 \right]^{0.8} \times 0.706^{1/3} = 105$$

$$\bar{h} = \overline{\text{Nu}}_L k/L = 105 \times 0.0269 \text{ W/m} \cdot \text{K} / 1 \text{ m} = 28.25 \text{ W/m}^2 \cdot \text{K}$$

$$R_{t,\text{conv}} = 1/\bar{h}A = \frac{1}{28.25 \text{ W/m}^2 \cdot \text{K} \times 1 \text{ m} \times 0.1 \text{ m}} = 354.0 \times 10^{-3} \text{ K/W}$$

Proceeding as in Part (a) we find

$$\eta = 0.242, T_3 = T_{\text{si}} = 38.0^\circ\text{C}, T_1 = 37.1^\circ\text{C}, R_{t,\text{rad}} = 1.768 \text{ K/W}, P = 14.06 \text{ W} \quad <$$

(c) Solving Equations 1 through 4 over the velocity range  $0 \leq u_m \leq 10 \text{ m/s}$  yields the following behavior

Continued...

### PROBLEM 7.18 (Cont.)

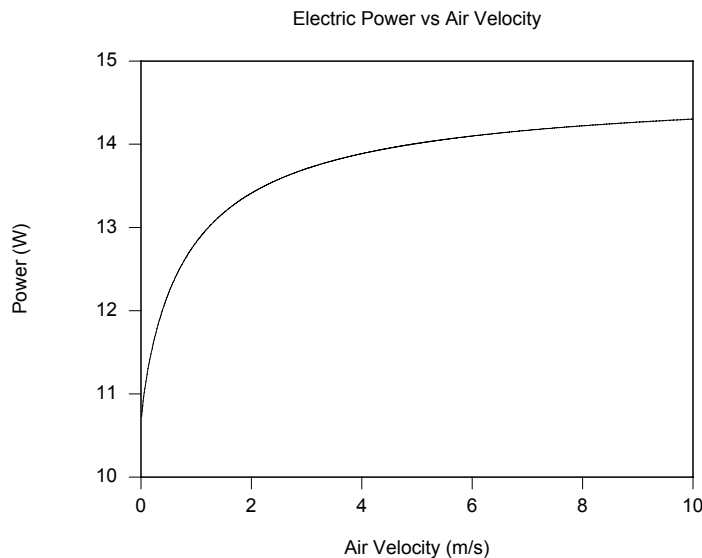
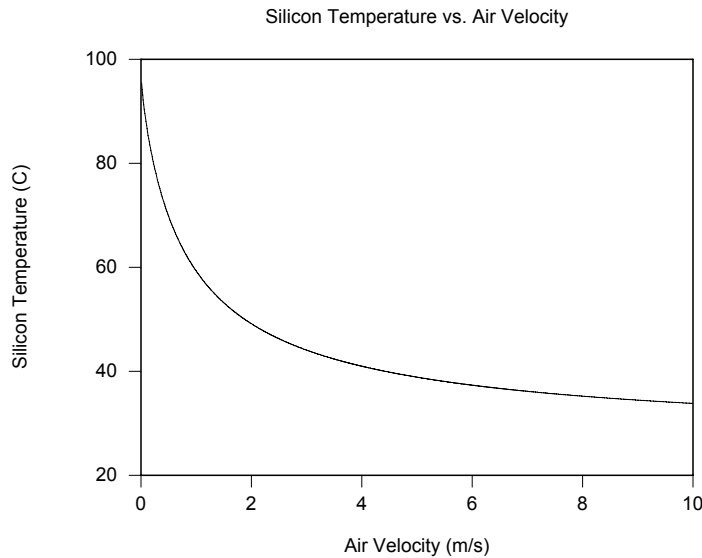

**COMMENTS:** (1) Changing the orientation of the solar panel to the  $L = 0.1$  m configuration reduces the temperature of the silicon semiconductor significantly. The influence of the orientation on the electric power would be more pronounced for warmer air temperatures. (2) Decreasing the air velocity results in significantly diminished power output. At very low cross flow velocities, natural convection would become significant and would lead to slightly improved power output relative to that predicted here. (3) Film temperatures for Parts (a) and (b) are  $31.9$  °C and  $28.6$  °C, respectively. The assumed value of the film temperature is good.

## PROBLEM 7.19

**KNOWN:** Dimensions of a photovoltaic cell, cooling air velocity and temperature, size of concentrating lens, photovoltaic construction and properties.

**FIND:** (a) The electric power output and silicon temperature of a system consisting of a 400 mm × 400 mm concentrating lens and a 100 mm × 100 mm photovoltaic cell, (b) Variation of the electric power output and silicon temperature for 100 mm ≤  $L_{\text{lens}}$  ≤ 600 mm.

**SCHEMATIC:**

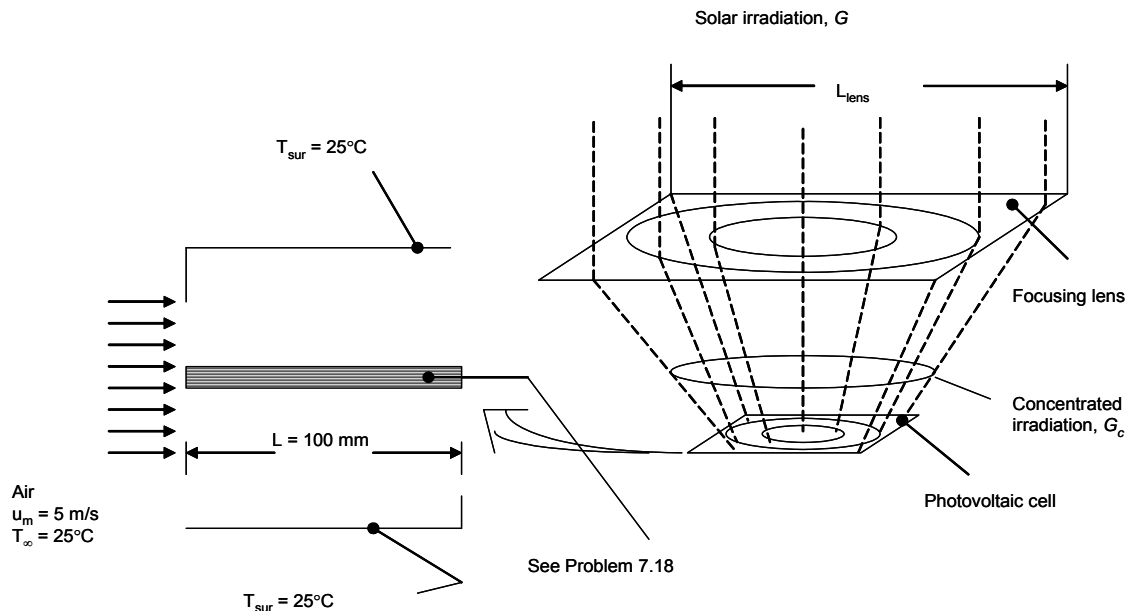

**ASSUMPTIONS:** (1) Steady-state conditions, (2) Constant properties, (3) One-dimensional heat transfer, (4) Tripped and turbulent boundary layer, (5) Large surroundings, (6) Negligible contact resistances.

**PROPERTIES:** Given, Glass:  $k_g = 1.4 \text{ W/m}\cdot\text{K}$ ,  $\varepsilon_g = 0.90$ , Adhesive:  $k_a = 145 \text{ W/m}\cdot\text{K}$ , Solder,  $k_s = 50 \text{ W/m}\cdot\text{K}$ , Aluminum nitride:  $k_{an} = 120 \text{ W/m}\cdot\text{K}$ , Table A.4, air (assume  $T_f = 70^\circ\text{C}$ ):  $k = 0.02948 \text{ W/m}\cdot\text{K}$ ,  $\nu = 2.022 \times 10^{-5} \text{ m}^2/\text{s}$ ,  $\text{Pr} = 0.701$ .

**ANALYSIS:**

(a) We begin by drawing the thermal circuit,

Continued...

**PROBLEM 7.19 (Cont.)**

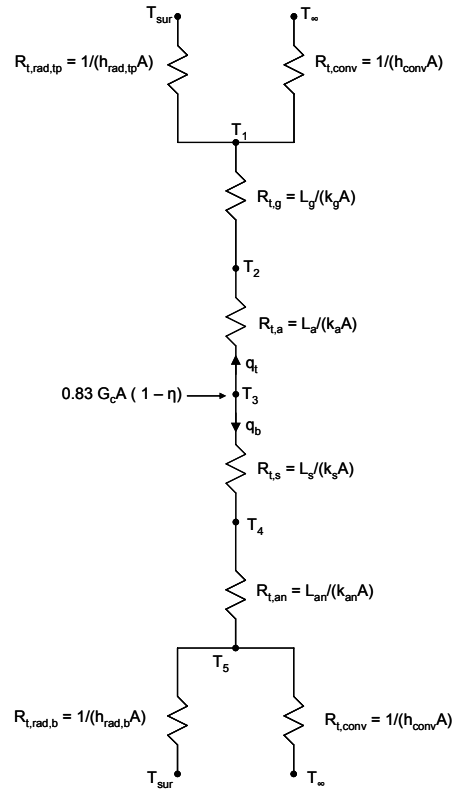

The thermal resistances are

$$R_{t,g} = L_g / (k_g A) = 3 \times 10^{-3} \text{ m} / (1.4 \text{ W/m} \cdot \text{K} \times 0.1 \text{ m} \times 0.1 \text{ m}) = 0.2143 \text{ K/W}$$

$$R_{t,a} = L_a / (k_a A) = 0.1 \times 10^{-3} \text{ m} / (145 \text{ W/m} \cdot \text{K} \times 0.1 \text{ m} \times 0.1 \text{ m}) = 6.897 \times 10^{-5} \text{ K/W}$$

$$R_{t,s} = L_s / (k_s A) = 0.1 \times 10^{-3} \text{ m} / (50 \text{ W/m} \cdot \text{K} \times 0.1 \text{ m} \times 0.1 \text{ m}) = 200 \times 10^{-6} \text{ K/W}$$

$$R_{t,an} = L_{an} / (k_{an} A) = 2 \times 10^{-3} \text{ m} / (120 \text{ W/m} \cdot \text{K} \times 0.1 \text{ m} \times 0.1 \text{ m}) = 1.67 \times 10^{-3} \text{ K/W}$$

$$h_{\text{rad,tp}} = \epsilon_g \sigma (T_1 + T_{\text{sur}})(T_1^2 + T_{\text{sur}}^2)$$

$$R_{t,\text{rad,tp}} = \frac{1}{0.9 \times 5.67 \times 10^{-8} \text{ W/m}^2 \cdot \text{K}^4 \times (T_1 + 298 \text{ K}) \times (T_1^2 + (298 \text{ K})^2)} \quad (1)$$

$$h_{\text{rad,b}} = \epsilon_b \sigma (T_5 + T_{\text{sur}})(T_5^2 + T_{\text{sur}}^2)$$

$$R_{t,\text{rad,b}} = \frac{1}{0.95 \times 5.67 \times 10^{-8} \text{ W/m}^2 \cdot \text{K}^4 \times (T_5 + 298 \text{ K}) \times (T_5^2 + (298 \text{ K})^2)} \quad (2)$$

For the top and bottom tripped boundary layers,

$$\text{Re}_L = \frac{u_\infty L}{\nu} = \frac{5 \text{ m/s} \times 0.1 \text{ m}}{2.022 \times 10^{-5} \text{ m}^2/\text{s}} = 24.73 \times 10^3$$

From Equation 7.38

Continued...

**PROBLEM 7.19 (Cont.)**

$$\overline{Nu}_L = 0.037Re_L^{4/5}Pr^{1/3} = 0.037 \times [24.73 \times 10^3]^{0.8} \times 0.701^{1/3} = 107.5$$

$$\bar{h} = \overline{Nu}_L k/L = \frac{107.5 \times 0.02948 \text{ W/m} \cdot \text{K}}{0.1 \text{ m}} = 31.69 \text{ W/m}^2 \cdot \text{K}$$

$$R_{t,conv} = 1/\bar{h}A = \frac{1}{(31.69 \text{ W/m}^2 \cdot \text{K} \times 0.1 \text{ m} \times 0.1 \text{ m})} = 3.155 \text{ K/W}$$

From the thermal circuit,

$$\begin{aligned} 0.83G_c A (1 - \eta) &= 0.83G (L_{\text{lens}}/L)^2 A (1 - \eta) = q_t + q_b \\ 0.83 \times 700 \text{ W/m}^2 \times 4^2 \times 0.1 \text{ m} \times 0.1 \text{ m} \times (1 - \eta) &= q_t + q_b \\ 9296 \text{ W} &= (q_t + q_b)/(1 - \eta) \end{aligned} \quad (3)$$

where

$$q_t = (T_3 - T_1)/(R_{t,a} + R_{t,g}) = (T_3 - T_1)/0.2144 \text{ K/W} \quad (4)$$

and

$$\begin{aligned} q_b &= (T_1 - T_{\text{sur}})/R_{t,rad,tp} + (T_1 - T_{\infty})/R_{t,conv} \\ &= (T_1 - 298 \text{ K})/R_{t,rad,tp} + (T_1 - 298 \text{ K})/3.155 \text{ K/W} \end{aligned} \quad (5)$$

Likewise

$$q_b = (T_3 - T_5)/(R_{t,s} + R_{t,an}) = (T_3 - T_5)/1.87 \times 10^{-3} \text{ K/W} \quad (6)$$

and

$$\begin{aligned} q_b &= (T_5 - T_{\text{sur}})/R_{t,rad,b} + (T_5 - T_{\infty})/R_{t,conv} \\ &= (T_5 - 298 \text{ K})/R_{t,rad,b} + (T_5 - 298 \text{ K})/3.155 \text{ K/W} \end{aligned} \quad (7)$$

The solar-to-electrical conversion efficiency is

$$\eta = 0.28 - 0.001^\circ\text{C}^{-1} \times (T_3 - 273)^\circ\text{C} \quad (8)$$

Equations (1) through (8) may be solved simultaneously to yield

$$\begin{aligned} T_{si} = T_3 - 273 &= 125.9^\circ\text{C}, \eta = 0.1541, T_1 = 390.9 \text{ K}, T_5 = 398.8 \text{ K}, \\ R_{t,rad,tp} &= 11.78 \text{ K/W}, R_{t,rad,b} = 10.75 \text{ K/W}, q_t = 37.32 \text{ W}, q_b = 41.32 \text{ W}. \end{aligned}$$

The electric power produced is

$$\begin{aligned} P &= 0.83G (L_{\text{lens}}/L)^2 A \eta \\ &= 0.83 \times 700 \text{ W/m}^2 \times 4^2 \times 0.1 \text{ m} \times 0.1 \text{ m} \times 0.1541 = 14.33 \text{ W} \end{aligned}$$

<  
Continued...

### PROBLEM 7.19 (Cont.)

(b) The *IHT* Software may be used to investigate the sensitivity of the silicon temperature and the electric power produced in response to the concentrating lense size. Results are shown below. <

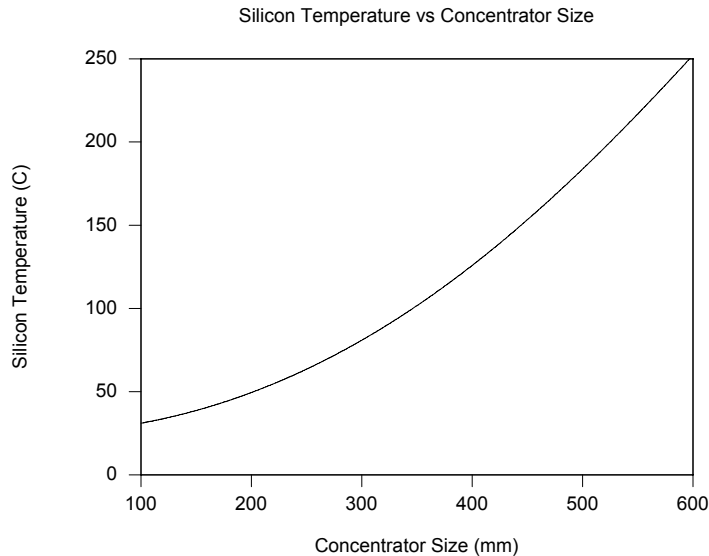
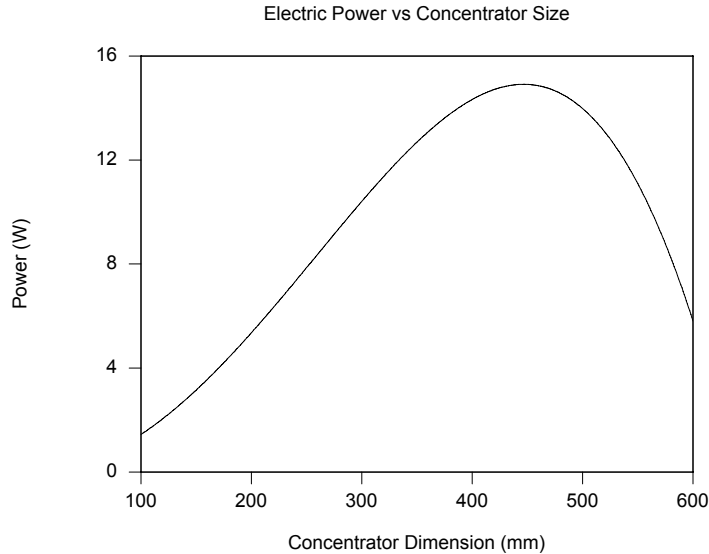

**COMMENTS:** (1) The electric power output is highly sensitive to the size of the concentrating lens. The concentrated irradiation continually increases as the concentrator is made larger until, eventually, the silicon temperature becomes very high and the solar-to-electrical conversion efficiency becomes small. (2) The electric power could be increased if heat sinks and/or liquid cooling could be applied to the solar cell, keeping the silicon temperature low and the conversion efficiency relatively high. (3) The assumed film temperature is a good estimate since  $T_{f,fp} = 71.4$  °C and  $T_{f,bot} = 75.4$  °C.

## PROBLEM 7.20

**KNOWN:** Material properties, inner surface temperature and dimensions of roof of refrigerated truck compartment. Truck speed and ambient temperature. Solar irradiation.

**FIND:** (a) Outer surface temperature of roof and rate of heat transfer to compartment, (b) Effect of changing radiative properties of outer surface, (c) Effect of eliminating insulation.

**SCHEMATIC:**

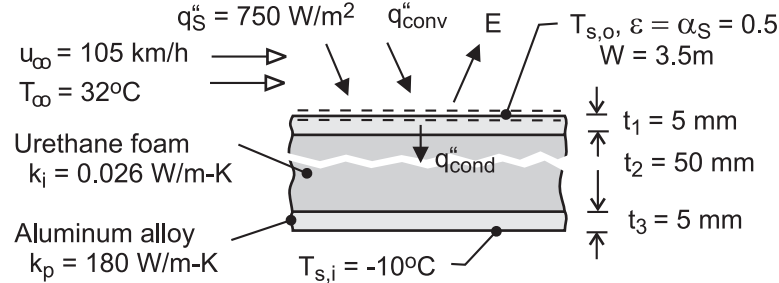

**ASSUMPTIONS:** (1) Negligible irradiation from the sky, (2) Turbulent flow over entire outer surface, (3) Average convection coefficient may be used to estimate average surface temperature, (4) Constant properties.

**PROPERTIES:** Table A-4, air ( $p = 1 \text{ atm}$ ,  $T_f \approx 300\text{K}$ ):  $\nu = 15.89 \times 10^{-6} \text{ m}^2/\text{s}$ ,  $k = 0.0263 \text{ W/m}\cdot\text{K}$ ,  $\text{Pr} = 0.707$ .

**ANALYSIS:** (a) From an energy balance for the outer surface,

$$\alpha_S G_S + q_{\text{conv}}'' - E = q_{\text{cond}}'' = \frac{T_{s,o} - T_{s,i}}{R_{\text{tot}}''}$$

$$\alpha_S G_S + \bar{h}(T_{\infty} - T_{s,o}) - \varepsilon \sigma T_{s,o}^4 = \frac{T_{s,o} - T_{s,i}}{2R_p'' + R_i''}$$

where  $R_p'' = (t_1/k_p) = 2.78 \times 10^{-5} \text{ m}^2 \cdot \text{K}/\text{W}$ ,  $R_i'' = (t_2/k_i) = 1.923 \text{ m}^2 \cdot \text{K}/\text{W}$ , and with  $\text{Re}_L = u_{\infty} L / \nu = 29.2 \text{ m/s} \times 10 \text{ m} / 15.89 \times 10^{-6} \text{ m}^2/\text{s} = 1.84 \times 10^7$ ,

$$\bar{h} = \frac{k}{L} 0.037 \text{Re}_L^{4/5} \text{Pr}^{1/3} = \frac{0.0263 \text{ W/m}\cdot\text{K}}{10 \text{ m}} 0.037 (1.84 \times 10^7)^{4/5} (0.707)^{1/3} = 56.2 \text{ W/m}^2 \cdot \text{K}$$

Hence,

$$0.5 \left( 750 \text{ W/m}^2 \cdot \text{K} \right) + 56.2 \text{ W/m}^2 \cdot \text{K} (305 - T_{s,o}) - 0.5 \times 5.67 \times 10^{-8} \text{ W/m}^2 \cdot \text{K}^4 T_{s,o}^4 = \frac{T_{s,o} - 263\text{K}}{\left( 5.56 \times 10^{-5} + 1.923 \right) \text{ m}^2 \cdot \text{K}/\text{W}}$$

Solving, we obtain

$$T_{s,o} = 306.8\text{K} = 33.8^\circ\text{C} \quad <$$

Hence, the heat load is

$$q = (W \cdot L) q_{\text{cond}}'' = (3.5 \text{ m} \times 10 \text{ m}) \frac{(33.8 + 10)^\circ\text{C}}{1.923 \text{ m}^2 \cdot \text{K}/\text{W}} = 797 \text{ W} \quad <$$

(b) With the special surface finish ( $\alpha_S = 0.15$ ,  $\varepsilon = 0.8$ ),

Continued ...

**PROBLEM 7.20 (Cont.)**

$$T_{s,o} = 300.1\text{K} = 27.1^\circ\text{C} \quad <$$

$$q = 675.3\text{W} \quad <$$

(c) Without the insulation ( $t_2 = 0$ ) and with  $\alpha_s = \varepsilon = 0.5$ ,

$$T_{s,o} = 263.1\text{K} = -9.9^\circ\text{C} \quad <$$

$$q = 90,630\text{W} \quad <$$

**COMMENTS:** (1) Use of the special surface finish reduces the solar input, while increasing radiation emission from the surface. The cumulative effect is to reduce the heat load by 15%. (2) The thermal resistance of the aluminum panels is negligible, and without the insulation, the heat load is *enormous*.

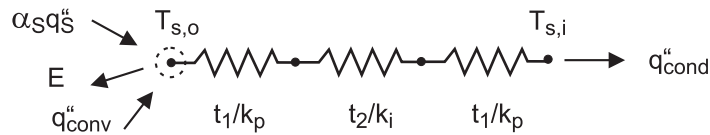



### PROBLEM 7.21

**KNOWN:** Surface characteristics of a flat plate in an air stream.

**FIND:** Orientation which minimizes convection heat transfer.

**SCHEMATIC:**

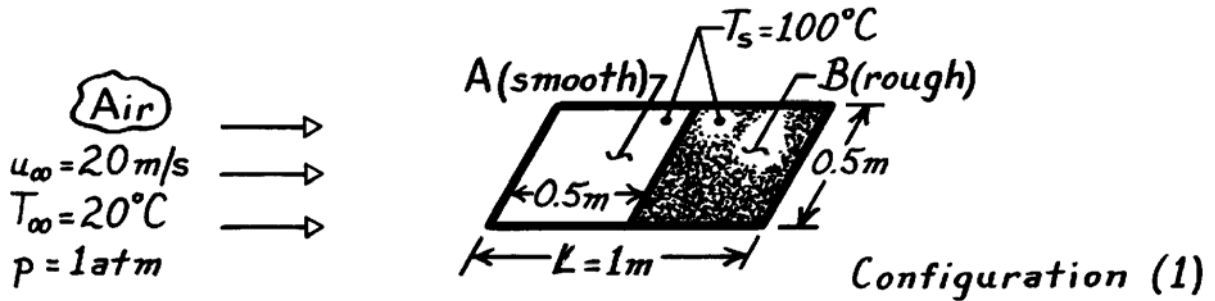

**ASSUMPTIONS:** (1) Surface B is sufficiently rough to trip the boundary layer when in the upstream position (Configuration 2).

**PROPERTIES:** Table A-4, Air ( $T_f = 333\text{ K}$ , 1 atm):  $\nu = 19.2 \times 10^{-6}\text{ m}^2/\text{s}$ ,  $k = 28.7 \times 10^{-3}\text{ W/m}\cdot\text{K}$ ,  $\text{Pr} = 0.7$ .

**ANALYSIS:** Since Configuration (2) results in a turbulent boundary layer over the entire surface, the lowest heat transfer is associated with Configuration (1). Find

$$\text{Re}_L = \frac{u_\infty L}{\nu} = \frac{20\text{ m/s} \times 1\text{ m}}{19.2 \times 10^{-6}\text{ m}^2/\text{s}} = 1.04 \times 10^6.$$

Hence in Configuration (1), transition will occur just before the rough surface ( $x_c = 0.48\text{ m}$ ). Note that

$$\begin{aligned} \overline{\text{Nu}}_{L,1} &= \left[ 0.037 \left( 1.04 \times 10^6 \right)^{4/5} - 871 \right] 0.7^{1/3} = 1366 \\ \overline{\text{Nu}}_{L,2} &= 0.037 \left( 1.04 \times 10^6 \right)^{4/5} (0.7)^{1/3} = 2139 > \overline{\text{Nu}}_{L,1}. \end{aligned}$$

For Configuration (1):

$$\frac{\overline{h}_{L,1} L}{k} = \overline{\text{Nu}}_{L,1} = 1366.$$

Hence

$$\overline{h}_{L,1} = 1366 \left( 28.7 \times 10^{-3}\text{ W/m}\cdot\text{K} \right) / 1\text{ m} = 39.2\text{ W/m}^2 \cdot \text{K}$$

and

$$q_1 = \overline{h}_{L,1} A (T_s - T_\infty) = 39.2\text{ W/m}^2 \cdot \text{K} (0.5\text{ m} \times 1\text{ m}) (100 - 20)\text{ K}$$

$$q_1 = 1568\text{ W}.$$

<

## PROBLEM 7.22

**KNOWN:** Dimensions and orientation of a flat plate placed in atmospheric airstream, airstream velocity and temperature, plate temperature.

**FIND:** The average convection coefficient for the entire surface.

**SCHEMATIC:**

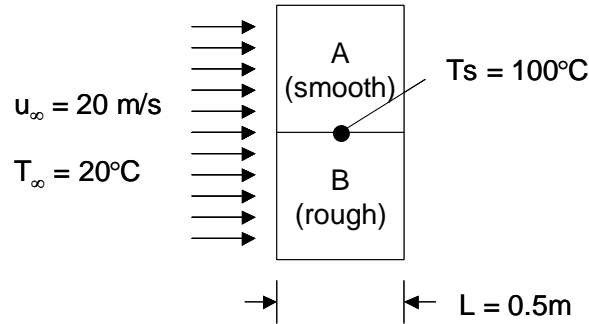

**ASSUMPTIONS:** (1) Steady-state conditions, (2) Constant properties, (3) Boundary layer on rough plate is tripped at leading edge, (4) Transition occurs at  $Re_{x,c} = 500,000$ .

**PROPERTIES:** Table A.4, air ( $T_f = 60^\circ\text{C} = 333\text{K}$ ,  $p = 1\text{ atm}$ ):  $\nu = 19.24 \times 10^{-6}\text{ m}^2/\text{s}$ ,  $Pr = 0.702$ ,  $k = 0.0288\text{ W/m}\cdot\text{K}$ .

**ANALYSIS:** For both the smooth and rough sections of the plate,

$$Re_L = \frac{u_\infty L}{\nu} = \frac{20\text{ m/s} \times 0.5\text{ m}}{19.24 \times 10^{-6}\text{ m}^2/\text{s}} = 520,000$$

Therefore, flow over portion A of the plate is nearly all laminar except near the trailing edge.

For portion A, Eq. 7.38 yields

$$\bar{h}_A = \frac{k}{L} \left[ 0.037 Re_L^{4/5} - 871 \right] Pr^{1/3} = \frac{0.0288\text{ W/m}\cdot\text{K}}{0.5\text{ m}} \left[ 0.037 \times 520,000^{4/5} - 871 \right] 0.702^{1/3} = 26.2\text{ W/m}^2 \cdot \text{K}$$

For portion B, Eq. 7.38 yields

$$\bar{h}_B = \frac{k}{L} \left[ 0.037 Re_L^{4/5} \right] Pr^{1/3} = \frac{0.0288\text{ W/m}\cdot\text{K}}{0.5\text{ m}} \left[ 0.037 \times 520,000^{4/5} \right] 0.702^{1/3} = 70.8\text{ W/m}^2 \cdot \text{K}$$

Therefore, for the entire plate consisting of half portion A and half portion B,

$$\bar{h} = \frac{\bar{h}_A + \bar{h}_B}{2} = 48.5\text{ W/m}^2 \cdot \text{K} \quad <$$

**COMMENTS:** (1) The value of the average coefficient for orientations 1 and 2 of Problem 7.21 are  $\bar{h}_1 = 39.2\text{ W/m}^2 \cdot \text{K}$  and  $\bar{h}_2 = 61.4\text{ W/m}^2 \cdot \text{K}$ , respectively. The average heat transfer coefficient found here is approximately midway between the values associated with the other two orientations. This is coincidental, since the nature of the flow is very different for the three different orientations. (2) In reality, boundary layer development *cannot* proceed on the smooth and rough parts of the plate independent of the other part of the plate, as implied in the solution above. Rather, there will be an intermediate region that will be characterized by complex flow and heat transfer phenomena. The solution should be viewed as a first approximation of actual heat transfer conditions.

### PROBLEM 7.23

**KNOWN:** Design of an anemometer comprised of a thin metallic strip supported by stiff rods serving as electrodes for passage of heating current. Fine-wire thermocouple on trailing edge of strip.

**FIND:** (a) Relationship between electrical power dissipation per unit width of the strip in the transverse direction,  $P'$  (mW/mm), and airstream velocity  $u_\infty$  when maintained at constant strip temperature,  $T_s$ ; show the relationship graphically; (b) The uncertainty in the airstream velocity if the accuracy with which the strip temperature can be measured and maintained constant is  $\pm 0.2^\circ\text{C}$ ; (c) Relationship between strip temperature and airstream velocity  $u_\infty$  when the strip is provided with a constant power,  $P' = 30$  mW/mm; show the relationship graphically. Also, find the uncertainty in the airstream velocity if the accuracy with which the strip temperature can be measured is  $\pm 0.2^\circ\text{C}$ ; (d) Compare features associated with each of the operating modes.

**SCHEMATIC:**

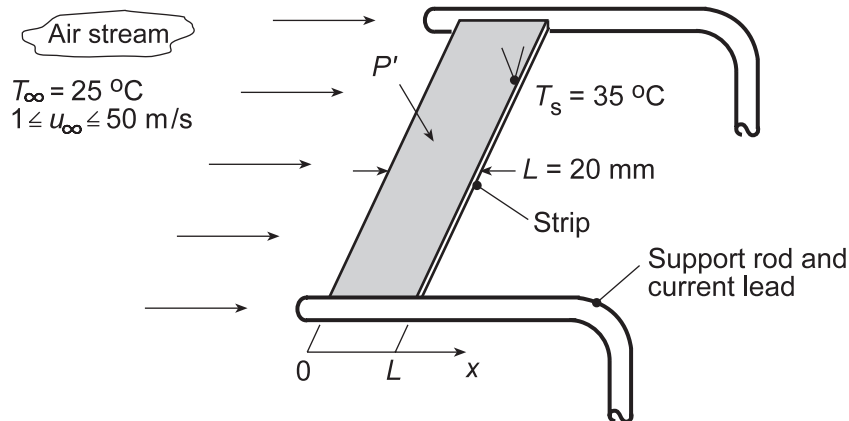

**ASSUMPTIONS:** (1) Steady-state conditions, (2) Constant properties, (3) Strip has uniform temperature in the midspan region of the strip, (4) Negligible conduction in the transverse direction in the midspan region, and (5) Airstream over strip approximates parallel flow over two sides of a smooth flat plate.

**ANALYSIS:** (a) In the midspan region of uniform temperature  $T_s$  with no conduction in the transverse direction, all the dissipated electrical power is transferred by convection to the airstream,

$$P' = 2\bar{h}_L L (T_s - T_\infty) \quad (1)$$

where  $P'$  is the power per unit width (transverse direction). Using the *IHT Correlation Tool for External Flow-Flat Plate* the power as a function of airstream velocity was determined and is plotted below. The IHT tool uses the flat plate correlation, Eq. 7.30 since the flow is laminar over this velocity range.

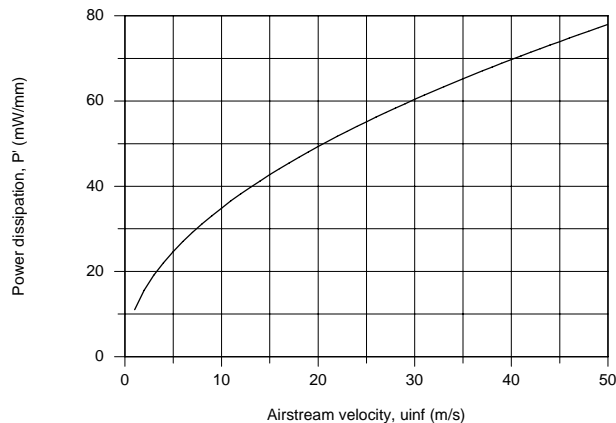

Continued...

### PROBLEM 7.23 (Cont.)

(b) By differentiation of Eq. (1), the relative uncertainties of the convection coefficient and strip temperature are, assuming the power remains constant,

$$\frac{\Delta \bar{h}_L}{\bar{h}} = - \frac{\Delta T_s}{T_s - T_\infty} \quad (2)$$

Since the flow was laminar for the range of airstream velocities, Eq. 7.30,

$$\bar{h}_L \sim u_\infty^{1/2} \quad \text{or} \quad \frac{\Delta \bar{h}_L}{\bar{h}_L} = 0.5 \frac{\Delta u_\infty}{u_\infty} \quad (3)$$

Hence, the relative uncertainty in the air velocity due to uncertainty in  $T_s$ ,  $\Delta T_s = \pm 0.2^\circ \text{C}$

$$\frac{\Delta u_\infty}{u_\infty} = 2 \frac{\Delta T_s}{T_s - T_\infty} = 2 \frac{\pm 0.2^\circ \text{C}}{(35 - 25)^\circ \text{C}} = \pm 4\% \quad (4) \leftarrow$$

(c) Using the IHT workspace setting  $P' = 30 \text{ mW/mm}$ , the strip temperature  $T_s$  as a function of the airstream velocity was determined and plotted. Note that the slope of the  $T_s$  vs.  $u_\infty$  curve is steep for low velocities and relatively flat for high velocities. That is, the technique is more sensitive at lower velocities. Using Eq. (4), but with  $T_s$  dependent upon  $u_\infty$ , the relative uncertainty in  $u_\infty$  can be determined.

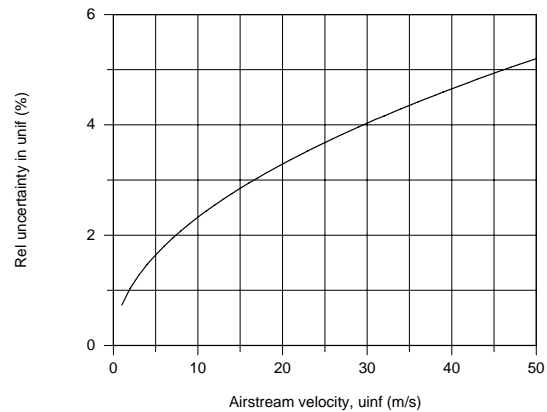
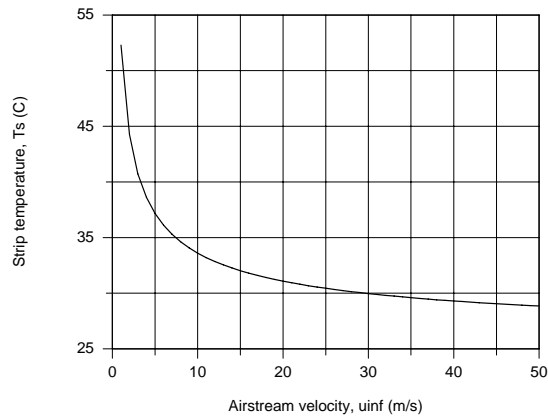

(d) For the constant power mode of operation, part (a), the uncertainty in  $u_\infty$  due to uncertainty in temperature measurement was found as 4%, independent of the magnitude  $u_\infty$ . For the constant-temperature mode of operation, the uncertainty in  $u_\infty$  is less than 4% for velocities less than 30 m/s, with a value of 1% around 2 m/s. However, in the upper velocity range, the error increases to 5%.

## PROBLEM 7.24

**KNOWN:** Plate dimensions and initial temperature. Velocity and temperature of air in parallel flow over plates.

**FIND:** Initial rate of heat transfer from plate. Rate of change of plate temperature.

**SCHEMATIC:**

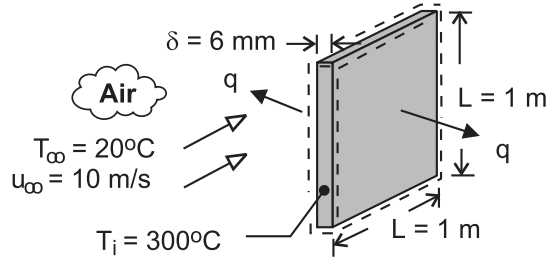

**ASSUMPTIONS:** (1) Negligible radiation, (2) Negligible effect of conveyor velocity on boundary layer development, (3) Plates are isothermal, (4) Negligible heat transfer from sides of plate, (5)

$Re_{x,c} = 5 \times 10^5$ , (6) Constant properties.

**PROPERTIES:** Table A-1, AISI 1010 steel (573K):  $k_p = 49.2 \text{ W/m}\cdot\text{K}$ ,  $c = 549 \text{ J/kg}\cdot\text{K}$ ,  $\rho = 7832 \text{ kg/m}^3$ . Table A-4, Air ( $p = 1 \text{ atm}$ ,  $T_f = 433\text{K}$ ):  $\nu = 30.4 \times 10^{-6} \text{ m}^2/\text{s}$ ,  $k = 0.0361 \text{ W/m}\cdot\text{K}$ ,  $Pr = 0.688$ .

**ANALYSIS:** The initial rate of heat transfer from a plate is

$$q = 2 \bar{h} A_s (T_i - T_\infty) = 2 \bar{h} L^2 (T_i - T_\infty)$$

With  $Re_L = u_\infty L / \nu = 10 \text{ m/s} \times 1 \text{ m} / 30.4 \times 10^{-6} \text{ m}^2/\text{s} = 3.29 \times 10^5$ , flow is laminar over the entire surface and

$$\overline{Nu}_L = 0.664 Re_L^{1/2} Pr^{1/3} = 0.664 (3.29 \times 10^5)^{1/2} (0.688)^{1/3} = 336$$

$$\bar{h} = (k/L) \overline{Nu}_L = (0.0361 \text{ W/m}\cdot\text{K} / 1 \text{ m}) 336 = 12.1 \text{ W/m}^2 \cdot \text{K}$$

Hence,

$$q = 2 \times 12.1 \text{ W/m}^2 \cdot \text{K} (1 \text{ m})^2 (300 - 20)^\circ\text{C} = 6780 \text{ W} \quad <$$

Performing an energy balance at an instant of time for a control surface about the plate,  $-\dot{E}_{\text{out}} = \dot{E}_{\text{st}}$ , we obtain,

$$\rho \delta L^2 c \left. \frac{dT}{dt} \right|_i = -\bar{h} 2L^2 (T_i - T_\infty)$$

$$\left. \frac{dT}{dt} \right|_i = -\frac{2(12.1 \text{ W/m}^2 \cdot \text{K})(300 - 20)^\circ\text{C}}{7832 \text{ kg/m}^3 \times 0.006 \text{ m} \times 549 \text{ J/kg}\cdot\text{K}} = -0.26^\circ\text{C/s} \quad <$$

**COMMENTS:** (1) With  $Bi = \bar{h}(\delta/2)/k_p = 7.4 \times 10^{-4}$ , use of the lumped capacitance method is appropriate. (2) Despite the large plate temperature and the small convection coefficient, if adjoining plates are in close proximity, radiation exchange with the surroundings will be small and the assumption of negligible radiation is justifiable.

## PROBLEM 7.25

**KNOWN:** Prevailing wind with prescribed speed blows past ten window panels, each of 1-m length, on a penthouse tower.

**FIND:** (a) Average convection coefficient for the first, third and tenth window panels when the wind speed is 5 m/s; evaluate thermophysical properties at 300 K, but determine suitability when ambient air temperature is in the range  $-15 \leq T_\infty \leq 38^\circ\text{C}$ ; (b) Compute and plot the average coefficients for the same panels with wind speeds for the range  $5 \leq u_\infty \leq 100$  km/h; explain features and relative magnitudes.

**SCHEMATIC:**

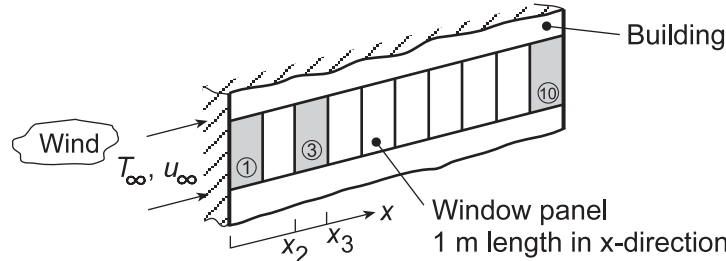

**ASSUMPTIONS:** (1) Steady-state conditions, (2) Constant properties, (3) Wind over panels approximates parallel flow over a smooth flat plate, and (4) Transition Reynolds number is  $Re_{x,c} = 5 \times 10^5$ .

**PROPERTIES:** Table A.4, Air ( $T_f = 300$  K, 1 atm):  $\nu = 15.89 \times 10^{-6}$  m<sup>2</sup>/s,  $k = 26.3 \times 10^{-3}$  W/m·K,  $Pr = 0.707$ .

**ANALYSIS:** (a) The average convection coefficients for the first, third and tenth panels are

$$\bar{h}_1 \quad \bar{h}_{2-3} = \frac{\bar{h}_3 x_3 - \bar{h}_2 x_2}{x_3 - x_2} \quad \bar{h}_{9-10} = \frac{\bar{h}_{10} x_{10} - \bar{h}_9 x_9}{x_{10} - x_9} \quad (1,2,3)$$

where  $\bar{h}_2 = \bar{h}_2(x_2)$ , etc. If  $Re_{x,c} = 5 \times 10^5$ , with properties evaluated at  $T_f = 300$  K, transition occurs at

$$x_c = \frac{\nu}{u_\infty} Re_{x,c} = \frac{15.89 \times 10^{-6} \text{ m}^2/\text{s}}{5 \text{ m/s}} \times 5 \times 10^5 = 1.59 \text{ m}$$

The flow over the first panel is laminar, and  $\bar{h}_1$  can be estimated using Eq. (7.30).

$$\overline{Nu}_{x1} = \frac{\bar{h}_1 x_1}{k} = 0.664 Re_x^{1/2} Pr^{1/3}$$

$$\bar{h}_1 = (0.0263 \text{ W/m} \cdot \text{K} \times 0.664/\text{lm}) \left( 5 \text{ m/s} \times 1\text{m} / 15.89 \times 10^{-6} \text{ m}^2/\text{s} \right)^{1/2} (0.707)^{1/3} = 8.73 \text{ W/m}^2 \cdot \text{K} <$$

The flow over the third and tenth panels is mixed, and  $\bar{h}_2$ ,  $\bar{h}_3$ ,  $\bar{h}_9$  and  $\bar{h}_{10}$  can be estimated using Eq. (7.41). For the third panel with  $x_3 = 3$  m and  $x_2 = 2$  m,

$$\overline{Nu}_{x3} = \frac{\bar{h}_3 x_3}{k} = \left( 0.037 Re_x^{4/5} - 871 \right) Pr^{1/3}$$

$$\bar{h}_3 = (0.0263 \text{ W/m} \cdot \text{K}/3\text{m}) \times \left[ 0.037 \left( 5 \text{ m/s} \times 3\text{m} / 15.89 \times 10^{-6} \text{ m}^2/\text{s} \right)^{4/5} - 871 \right] (0.707)^{1/3} = 10.6 \text{ W/m}^2 \cdot \text{K}$$

Continued...

**PROBLEM 7.25 (Cont.)**

$$\bar{h}_2 = (0.0263 \text{ W/m} \cdot \text{K}/2\text{m}) \times \left[ 0.037 \left( 5 \text{ m/s} \times 2\text{m} / 15.89 \times 10^{-6} \text{ m}^2/\text{s} \right)^{4/5} - 871 \right] (0.707)^{1/3} = 8.68 \text{ W/m}^2 \cdot \text{K}$$

From Eq. (2),

$$\bar{h}_{2-3} = \frac{10.61 \text{ W/m}^2 \cdot \text{K} \times 3\text{m} - 8.68 \text{ W/m}^2 \cdot \text{K} \times 2\text{m}}{(3-2)\text{m}} = 14.5 \text{ W/m}^2 \cdot \text{K} \quad <$$

Following the same procedure for the tenth panel, find  $\bar{h}_{10} = 11.64 \text{ W/m}^2 \cdot \text{K}$  and  $\bar{h}_9 = 11.71 \text{ W/m}^2 \cdot \text{K}$ , and

$$\bar{h}_{9-10} = 11.1 \text{ W/m}^2 \cdot \text{K} \quad <$$

Assuming that the window panel temperature will always be close to room temperature,  $T_s = 23^\circ\text{C} = 296 \text{ K}$ . If  $T_\infty$  ranges from  $-15$  to  $38^\circ\text{C}$ , the film temperature,  $T_f = (T_s + T_\infty)/2$ , will vary from  $275$  to  $310 \text{ K}$ . We'll explore the effect of  $T_f$  subsequently.

(b) Using the *IHT Tool, Correlations, External Flow, Flat Plate*, results were obtained for the average coefficients  $\bar{h}$ . Using Eqs. (2) and (3), average coefficients for the panels as a function of wind speed were computed and plotted.

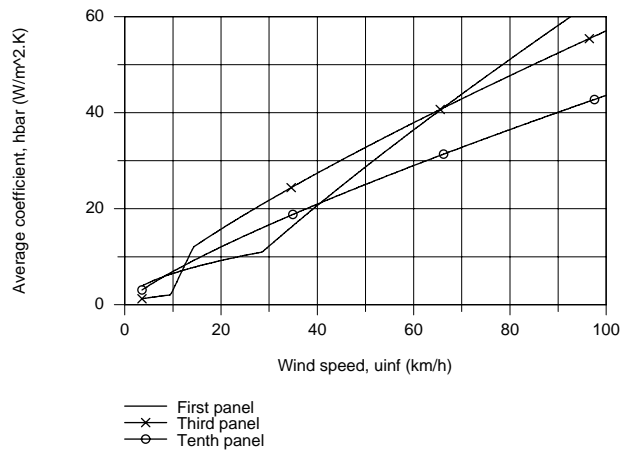

**COMMENTS:** (1) The behavior of the panel average coefficients as a function of wind speed can be explained from the behavior of the local coefficient as a function of distance for difference velocities as plotted below.

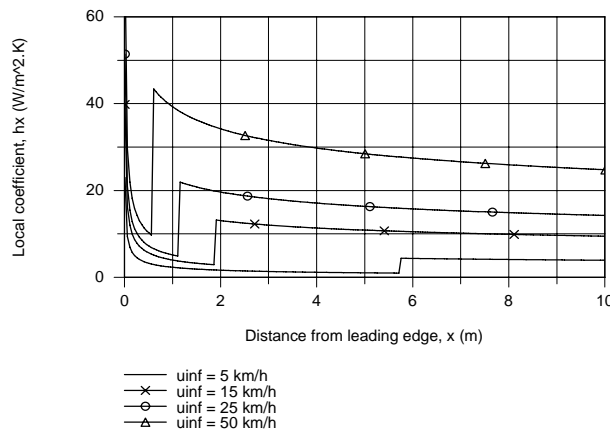

Continued...

### PROBLEM 7.25 (Cont.)

For low wind speeds, transition occurs near the mid-panel, making  $\bar{h}_1$  and  $\bar{h}_{9-10}$  nearly equal and very high because of leading-edge and turbulence effects, respectively. As the wind speed increases, transition occurs closer to the leading edge. Notice how  $\bar{h}_{2-3}$  increases rather abruptly, subsequently becoming greater than  $\bar{h}_{9-10}$ . The abrupt increase in  $\bar{h}_1$  around 30 km/h is a consequence of transition occurring with  $x < 1$  m.

(2) Using the IHT code developed for the foregoing analysis with  $u_\infty = 5$  m/s, the effect of  $T_f$  is tabulated below

$T_f$ (K)	275	300	310
$\bar{h}_1$ (W/m <sup>2</sup> ·K)	8.72	8.73	8.70
$\bar{h}_{2-3}$ (W/m <sup>2</sup> ·K)	15.1	14.5	14.2
$\bar{h}_{9-10}$ (W/m <sup>2</sup> ·K)	11.6	11.1	10.8

The overall effect of  $T_f$  on estimates for the average panel coefficient is slight, less than 5%.



## PROBLEM 7.26

**KNOWN:** Length and surface temperature of a rectangular fin.

**FIND:** (a) Heat removal per unit width,  $q'$ , when air at a prescribed temperature and velocity is in parallel, turbulent flow over the fin, and (b) Calculate and plot  $q'$  for motorcycle speeds ranging from 10 to 100 km/h.

**SCHEMATIC:**

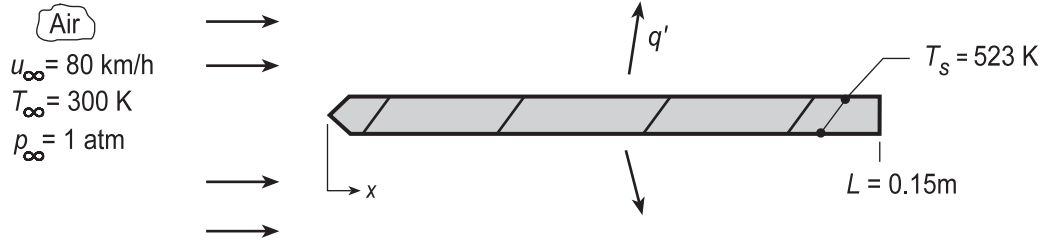

**ASSUMPTIONS:** (1) Steady-state conditions, (2) Negligible radiation, (3) Turbulent flow over entire surface.

**PROPERTIES:** Table A.4, Air (412 K, 1 atm):  $\nu = 27.85 \times 10^{-6} \text{ m}^2/\text{s}$ ,  $k = 0.0346 \text{ W/m}\cdot\text{K}$ ,  $\text{Pr} = 0.69$ .

**ANALYSIS:** (a) The heat loss per unit width is

$$q' = 2 \times [\bar{h}_L L (T_s - T_\infty)]$$

where  $\bar{h}$  is obtained from the correlation, Eq. 7.38 but with turbulent flow over the entire surface,

$$\overline{\text{Nu}}_L = 0.037 \text{Re}_L^{4/5} \text{Pr}^{1/3} = 0.037 \left[ \frac{80 \text{ km/h} \times 1000 \text{ m/km} \times 1/3600 \text{ h/s} \times 0.15 \text{ m}}{27.85 \times 10^{-6} \text{ m}^2/\text{s}} \right]^{4/5} (0.69)^{1/3} = 378$$

Hence,

$$\bar{h}_L = \frac{k}{L} \overline{\text{Nu}}_L = \frac{0.0346 \text{ W/m}\cdot\text{K}}{0.15 \text{ m}} 378 = 87 \text{ W/m}^2 \cdot \text{K}$$

$$q' = 2 \times [87 \text{ W/m}^2 \cdot \text{K} \times 0.15 \text{ m} (523 - 300) \text{ K}] = 5826 \text{ W/m}.$$

<

(b) Using the foregoing equations in the IHT Workspace,  $q'$  as a function of speed was calculated and is plotted as shown.

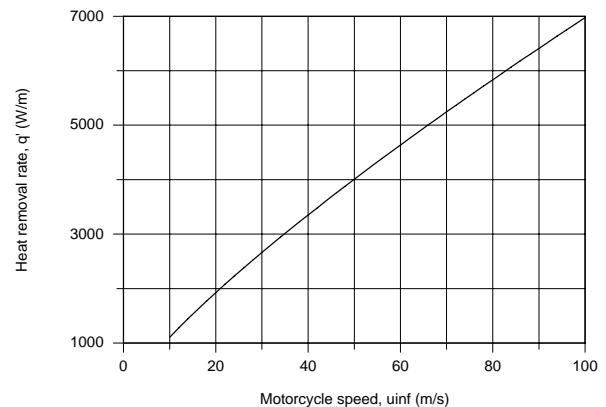

**COMMENTS:** (1) Radiation emission from the fin is not negligible. With an assumed emissivity of  $\varepsilon = 1$ , the rate of emission per unit width at 80 km/h would be  $q' = (\sigma T_s^4) 2L = 1273 \text{ W/m}$ . If the fin received negligible radiation from its surroundings, its loss by radiation would then be approximately 20% of that by convection.

(2) From the correlation and heat rate expression, it follows that  $q' \sim u_\infty^{4/5}$ . That is,  $q'$  vs.  $u_\infty$  is nearly linear as evident from the above plot.

## PROBLEM 7.27

**KNOWN:** Wall of a metal building experiences a 10 mph (4.47 m/s) breeze with air temperature of 90°F (32.2°C) and solar insolation of 400 W/m<sup>2</sup>. The length of the wall in the wind direction is 10 m and the emissivity is 0.93.

**FIND:** Estimate the average wall temperature.

**SCHEMATIC:**

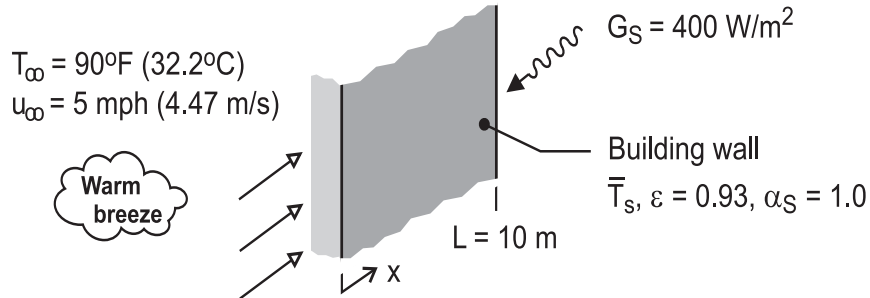

**ASSUMPTIONS:** (1) Steady-state conditions, (2) The solar absorptivity of the wall is unity, (3) Sky irradiation is negligible, (4) Wall is isothermal at the average temperature  $T_s$ , (5) Flow is fully turbulent over the wall, and (6) Negligible heat transfer into the building.

**PROPERTIES:** Table A-4, Air (assume  $T_f = 305$  K, 1 atm):  $\nu = 16.27 \times 10^{-6}$  m<sup>2</sup>/s,  $k = 0.02658$  W/m·K,  $Pr = 0.707$ .

**ANALYSIS:** Perform an energy balance on the wall surface considering convection, absorbed irradiation and emission. On a per unit width basis,

$$\begin{aligned} \dot{E}'_{in} - \dot{E}'_{out} &= 0 \\ -q'_{cv} + (\alpha_S G_S - E_s)L &= 0 \\ -\bar{h}_L L (T_s - T_\infty) + (\alpha_S G_S - \epsilon \sigma T_s^4)L &= 0 \end{aligned} \quad (1)$$

The average convection coefficient is estimated using Eq. 7.41 assuming fully turbulent flow over the length of the wall in the direction of the breeze.

$$\overline{Nu}_L = \frac{\bar{h}_L L}{k} = 0.037 Re_L^{4/5} Pr^{1/3} \quad (2)$$

$$Re_L = u_\infty L / \nu = 4.47 \text{ m/s} \times 10 \text{ m} / 16.27 \times 10^{-6} \text{ m}^2/\text{s} = 2.748 \times 10^6$$

$$\bar{h}_L = (0.02658 \text{ W/m} \cdot \text{K} / 10 \text{ m}) \times 0.037 \left( 2.748 \times 10^6 \right)^{4/5} (0.707)^{1/3} = 12.4 \text{ W/m}^2 \cdot \text{K}$$

Substituting numerical values into Eq. (1), find  $T_s$ .

$$\begin{aligned} -12.4 \text{ W/m}^2 \times 10 \text{ m} [T_s - (32.2 + 273)] \text{ K} \\ + \left[ 1.0 \times 400 \text{ W/m}^2 - 0.93 \times 5.67 \times 10^{-8} \text{ W/m}^2 \cdot \text{K}^4 T_s^4 \right] \times 10 \text{ m} = 0 \end{aligned}$$

$$T_s = 302.2 \text{ K} = 29^\circ\text{C} \quad <$$

**COMMENTS:** (1) The properties for the correlation should be evaluated at  $T_f = (T_s + T_\infty)/2 = 304$  K. The assumption of 305 K was reasonable.

(2) Is the heat transfer by the emission process significant? Would application of a low emissive coating be effective in reducing the wall temperature, assuming  $\alpha_S$  remained unchanged? Or, should a low solar absorbing coating be considered?

## PROBLEM 7.28

**KNOWN:** Velocity, initial temperature, and dimensions of aluminum strip on a production line. Velocity and temperature of air in counter flow over top surface of strip.

**FIND:** (a) Differential equation governing temperature distribution along the strip and expression for outlet temperature, (b) Value of outlet temperature for prescribed conditions.

**SCHEMATIC:**

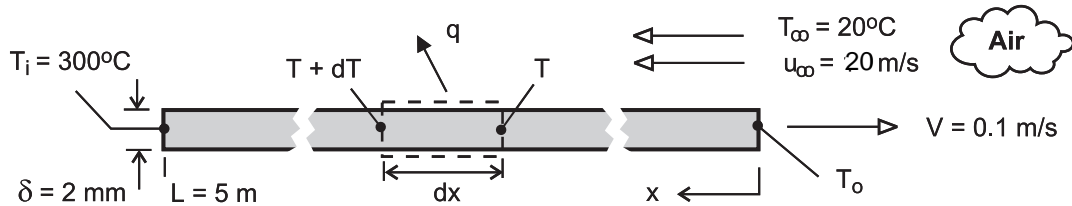

**ASSUMPTIONS:** (1) Negligible variation of sheet temperature across its thickness, (2) Negligible effect of conduction along length ( $x$ ) of sheet, (3) Negligible radiation, (4) Turbulent flow over entire top surface, (5) Negligible effect of sheet velocity on boundary layer development, (6) Negligible heat transfer from bottom surface and sides, (7) Constant properties.

**PROPERTIES:** Table A-1, Aluminum, 2024-T6 ( $\bar{T}_{AL} \approx 500\text{K}$ ):  $\rho = 2770\text{ kg/m}^3$ ,  $c_p = 983\text{ J/kg}\cdot\text{K}$ ,  $k = 186\text{ W/m}\cdot\text{K}$ . Table A-4, Air ( $p = 1\text{ atm}$ ,  $T_f \approx 400\text{K}$ ):  $\nu = 26.4 \times 10^{-6}\text{ m}^2/\text{s}$ ,  $k = 0.0338\text{ W/m}\cdot\text{K}$ ,  $Pr = 0.69$

**ANALYSIS:** (a) Applying conservation of energy to a stationary control surface, through which the sheet moves, steady-state conditions exist and  $\dot{E}_{in} - \dot{E}_{out} = 0$ . Hence, with *inflow* due to *advection* and *outflow* due to *advection* and *convection*,

$$\begin{aligned} \rho V A_c c_p (T + dT) - \rho V A_c c_p T - dq &= 0 \\ + \rho V \delta W c_p dT - h_x (dx \cdot W) (T - T_\infty) &= 0 \\ \frac{dT}{dx} &= + \frac{h_x}{\rho V \delta c_p} (T - T_\infty) \end{aligned} \quad (1) <$$

Alternatively, if the control surface is fixed to the sheet, conditions are transient and the energy balance is of the form,  $-\dot{E}_{out} = \dot{E}_{st}$ , or

$$\begin{aligned} -h_x (dx \cdot W) (T - T_\infty) &= \rho (dx \cdot W \cdot \delta) c_p \frac{dT}{dt} \\ \frac{dT}{dt} &= - \frac{h_x}{\rho \delta c_p} (T - T_\infty) \end{aligned}$$

Dividing the left- and right-hand sides of the equation by  $dx/dt$  and  $dx/dt = -V$ , respectively, equation (1) is obtained. The equation may be integrated from  $x = 0$  to  $x = L$  to obtain

$$\int_{T_o}^{T_i} \frac{dT}{T - T_\infty} = \frac{L}{\rho V \delta c_p} \left[ \frac{1}{L} \int_0^L h_x dx \right]$$

Continued ...

**PROBLEM 7.28 (Cont.)**

where  $h_x = (k/x)0.0296 \text{Re}_x^{4/5} \text{Pr}^{1/3}$  and the bracketed term on the right-hand side of the equation reduces to  $\bar{h}_L = (k/L)0.037 \text{Re}_L^{4/5} \text{Pr}^{1/3}$ .

Hence,

$$\ln\left(\frac{T_i - T_\infty}{T_o - T_\infty}\right) = \frac{L \bar{h}_L}{\rho V \delta c_p}$$

$$\frac{T_o - T_\infty}{T_i - T_\infty} = \exp\left(-\frac{L \bar{h}_L}{\rho V \delta c_p}\right) \quad <$$

(b) For the prescribed conditions,  $\text{Re}_L \approx u_\infty L / \nu = 20 \text{ m/s} \times 5 \text{ m} / 26.4 \times 10^{-6} \text{ m}^2/\text{s} = 3.79 \times 10^6$  and

$$\bar{h}_L = \left(\frac{0.0338 \text{ W/m}\cdot\text{K}}{5 \text{ m}}\right) 0.037 \left(3.79 \times 10^6\right)^{4/5} (0.69)^{1/3} = 40.5 \text{ W/m}^2 \cdot \text{K}$$

$$T_o = 20^\circ\text{C} + (280^\circ\text{C}) \exp\left(-\frac{5 \text{ m} \times 40.5 \text{ W/m}^2 \cdot \text{K}}{2770 \text{ kg/m}^3 \times 0.1 \text{ m/s} \times 0.002 \text{ m} \times 983 \text{ J/kg}\cdot\text{K}}\right) = 213^\circ\text{C} \quad <$$

**COMMENTS:** (1) With  $T_o = 213^\circ\text{C}$ ,  $\bar{T}_{\text{Al}} = 530\text{K}$  and  $T_f = 411\text{K}$  are close to values used to determine the material properties, and iteration is not needed. (2) For a representative emissivity of  $\varepsilon = 0.2$  and  $T_{\text{sur}} = T_\infty$ , the maximum value of the radiation coefficient is

$h_r = \varepsilon \sigma (T_i + T_{\text{sur}})(T_i^2 + T_{\text{sur}}^2) = 4.1 \text{ W/m}^2 \cdot \text{K} \ll \bar{h}_L$ . Hence, the assumption of negligible radiation is appropriate.

## PROBLEM 7.29

**KNOWN:** Dimensions of aluminum heat sink. Temperature and velocity of coolant (water) flow through the heat sink. Power dissipation of electronic package attached to the heat sink.

**FIND:** Base temperature of heat sink.

**SCHEMATIC:**

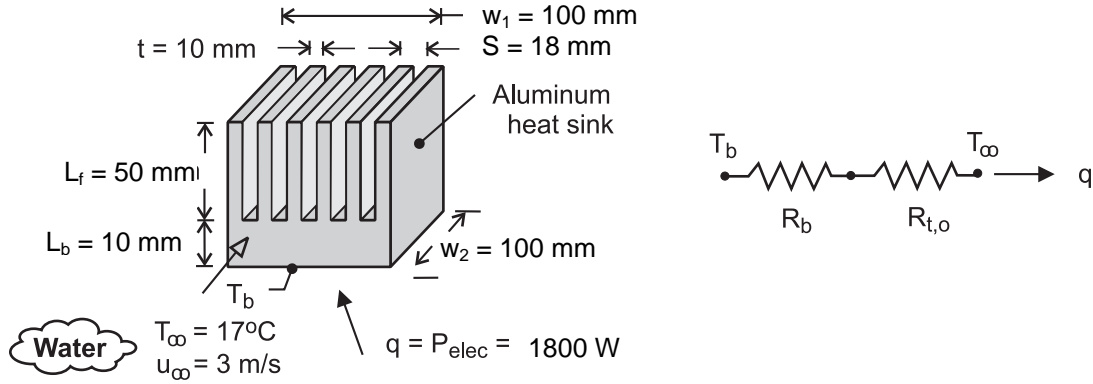

**ASSUMPTIONS:** (1) Average convection coefficient associated with flow over fin surfaces may be approximated as that for a flat plate in parallel flow, (2) All of the electric power is dissipated by the heat sink, (3) Transition Reynolds number of  $Re_{x,c} = 5 \times 10^5$ , (4) Constant properties. (5) Water temperature is nearly constant as it flows through the array.

**PROPERTIES:** Given. Aluminum:  $k_{hs} = 180 \text{ W/m}\cdot\text{K}$ . Water:  $k_w = 0.62 \text{ W/m}\cdot\text{K}$ ,  $\nu = 7.73 \times 10^{-7} \text{ m}^2/\text{s}$ ,  $Pr = 5.2$ .

**ANALYSIS:** From the thermal circuit,

$$q = P_{elec} = \frac{T_b - T_{\infty}}{R_b + R_{t,o}}$$

where  $R_b = L_b / k_{hs} (w_1 \times w_2) = 0.01 \text{ m} / 180 \text{ W/m}\cdot\text{K} (0.10 \text{ m})^2 = 5.56 \times 10^{-3} \text{ K/W}$  and, from Eqs. 3.107 and 3.108,

$$R_{t,o} = \left\{ \bar{h} A_t \left[ 1 - \frac{NA_f}{A_t} (1 - \eta_f) \right] \right\}^{-1}$$

The fin and total surface area of the array are  $A_f = 2w_2 (L_f + t/2) = 0.2 \text{ m} (0.055 \text{ m}) = 0.011 \text{ m}^2$  and  $A_t = NA_f + A_b = NA_f + (N-1)(S-t)w_2 = 6(0.011 \text{ m}^2) + 5(0.008 \text{ m})0.1 \text{ m} = (0.066 + 0.004) = 0.070 \text{ m}^2$ .

With  $Re_{w_2} = u_{\infty} w_2 / \nu = 3 \text{ m/s} \times 0.10 \text{ m} / 7.73 \times 10^{-7} \text{ m}^2/\text{s} = 3.88 \times 10^5$ , laminar flow may be assumed over the entire surface. Hence

$$\bar{h} = \left( \frac{k_w}{w_2} \right) 0.664 Re_{w_2}^{1/2} Pr^{1/3} = \left( \frac{0.62 \text{ W/m}\cdot\text{K}}{0.10 \text{ m}} \right) 0.664 (3.88 \times 10^5)^{1/2} (5.2)^{1/3} = 4443 \text{ W/m}^2 \cdot \text{K}$$

With  $m = (2\bar{h}/k_{hs}t)^{1/2} = (2 \times 4443 \text{ W/m}^2 \cdot \text{K} / 180 \text{ W/m}\cdot\text{K} \times 0.01 \text{ m})^{1/2} = 70.3 \text{ m}^{-1}$ ,  $mL_c = 70.3 \text{ m}^{-1} (0.055 \text{ m}) = 3.86$  and  $\tanh mL_c = 0.9991$ , Eq. 3.94 yields

$$\eta_f = \frac{\tanh mL_c}{mL_c} = \frac{0.9991}{3.86} = 0.259$$

Continued ...

### PROBLEM 7.29 (Cont.)

Hence,

$$R_{t,o} = \left\{ 4443 \text{ W/m}^2 \cdot \text{K} \times 0.070 \text{ m}^2 \left[ 1 - \frac{0.066 \text{ m}^2}{0.070 \text{ m}^2} (1 - 0.259) \right] \right\}^{-1} = 0.0107 \text{ K/W} \quad <$$

and

$$T_b = T_\infty + P_{\text{elec}} (R_b + R_{t,o}) = 17^\circ\text{C} + 1800 \text{ W} (5.56 \times 10^{-3} + 0.0107) \text{ K/W} = 46.2^\circ\text{C} \quad <$$

**COMMENTS:** (1) The boundary layer thickness at the trailing edge of the fin is

$\delta = 5w_2 / (\text{Re}_{w_2})^{1/2} = 0.80 \text{ mm} \ll (S - t)$ . Hence, the assumption of parallel flow over a flat plate is reasonable. (2) If a finned heat sink is not employed and heat transfer is simply by convection from the  $w_2 \times w_2$  base surface, the corresponding convection resistance would be  $0.0225 \text{ K/W}$ , which is only twice the resistance associated with the fin array. The small enhancement by the array is attributable to the large value of  $\bar{h}$  and the correspondingly small value of  $\eta_f$ . Were a fluid such as air or a dielectric liquid used as the coolant, the much smaller thermal conductivity would yield a smaller  $\bar{h}$ , a larger  $\eta_f$  and hence a larger effectiveness for the array. (3) The water outlet temperature may be calculated based the energy balance,  $q = \dot{m} c_p (T_{m,o} - T_{m,i})$  or  $T_{m,o} = 17^\circ\text{C} + 1800 \text{ W} / (5 \times 0.008 \text{ m} \times 0.05 \text{ m} \times 3 \text{ m/s} \times 995 \text{ kg/m}^3 \times 4178 \text{ J/kg}\cdot\text{K}) = 17.07^\circ\text{C}$  where there are  $N = 5$  channels. (The density and specific heat are evaluated at  $\text{Pr} = 5.2$ .) The assumption of constant water mean temperature is excellent. (4) If the increase in the water temperature was significant, an approach described in Chapter 11 would be needed to analyze the problem. See Problem 11.90.

### PROBLEM 7.30

**KNOWN:** Dimensions of a photovoltaic cell, material and dimensions of a finned heat sink, solar irradiation and dimensions of concentrating lens, velocity and temperature of dielectric liquid.

**FIND:** (a) Electric power produced and silicon temperature for a square concentrating lens with the heat sink in place, (b) Electric power and silicon temperature without the heat sink, (c) Electric power and silicon temperature for  $100 \text{ mm} \leq L_{\text{lens}} \leq 3000 \text{ mm}$ .

**SCHEMATIC:**

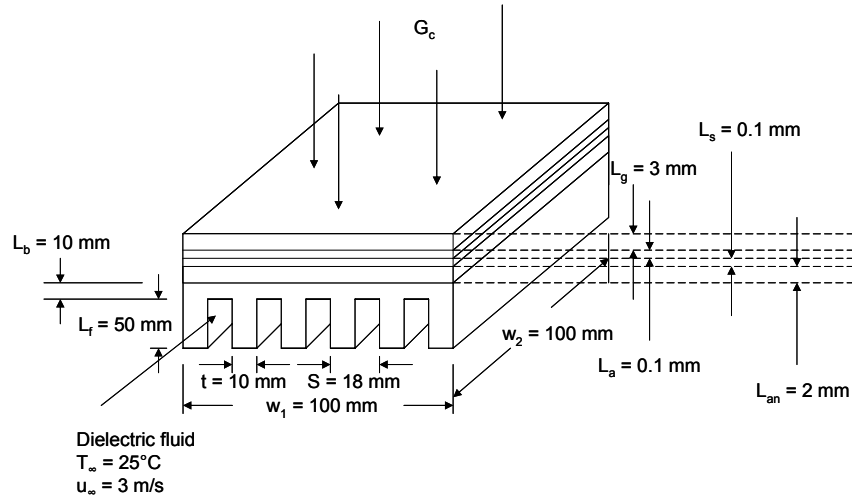

**ASSUMPTIONS:** (1) Steady-state conditions, (2) Constant properties, (3) One-dimensional heat transfer, (4) Average convection coefficient associated with flow over fin surfaces may be approximated as that for a flat plate in parallel flow, (5) Transition Reynolds number of  $Re_{x,c} = 5 \times 10^5$ , (6) Negligible convection off of the top of the solar cell, (7), No radiation to or through the dielectric liquid, (8) Negligible increase in dielectric fluid temperature as it flows through the array.

**PROPERTIES:** Given: Aluminum:  $k_{hs} = 180 \text{ W/m}\cdot\text{K}$ , Dielectric liquid:  $k_d = 0.064 \text{ W/m}\cdot\text{K}$ ,  $\nu = 10^{-6} \text{ m}^2/\text{s}$ ,  $\rho = 1400 \text{ kg/m}^3$ ,  $c_p = 1300 \text{ J/kg}\cdot\text{K}$ ,  $Pr = 25$ , Glass:  $k_g = 1.4 \text{ W/m}\cdot\text{K}$ , Adhesive:  $k_a = 145 \text{ W/m}\cdot\text{K}$ , Solder:  $k_s = 50 \text{ W/m}\cdot\text{K}$ , Aluminum Nitride:  $k_{an} = 120 \text{ W/m}\cdot\text{K}$ .

**ANALYSIS:** (a) The base resistance is

$$R_b = L_b/k_{hs}(w_1 \times w_2) = \frac{0.01\text{m}}{180 \text{ W/m}\cdot\text{K}(0.10\text{m})^2} = 5.56 \times 10^{-3} \text{ K/W}$$

and, from Equations 3.107 and 3.108

$$R_{t,o} = \left\{ \bar{h}A_t \left[ 1 - \frac{NA_f}{A_t}(1 - \eta_f) \right] \right\}^{-1}$$

The fin and total surface areas of the array are

$$A_f = 2w_2(L_f + t/2) = 0.20\text{m} \times (0.055\text{m}) = 0.0110 \text{ m}^2 \text{ and}$$

$$A_t = NA_f + A_b = NA_f + (N - 1)(S - t)w_2$$

$$= 6(0.0110 \text{ m}^2) + 5(0.008 \text{ m})(0.100 \text{ m}) = 0.0660 \text{ m}^2 + 0.0040 \text{ m}^2 = 0.071 \text{ m}^2$$

Continued...

### PROBLEM 7.30 (Cont.)

with  $Re_{w_2} = u_\infty w_2 / \nu = 3 \text{ m/s} \times 0.10 \text{ m} / 10^{-6} \text{ m}^2/\text{s} = 3.00 \times 10^5$ , laminar flow may be assumed over the entire surface. Hence

$$\begin{aligned} \bar{h} &= \left( \frac{k_w}{w_2} \right) 0.664 Re_{w_2}^{1/2} Pr^{1/3} \\ &= \left( \frac{0.064 \text{ W/m} \cdot \text{K}}{0.10 \text{ m}} \right) 0.664 (3.00 \times 10^5)^{1/2} (25)^{1/3} = 681 \text{ W/m}^2 \cdot \text{K} \end{aligned}$$

with  $m = (2\bar{h}/k_{hs}t)^{1/2} = \left[ 362 \text{ W/m}^2 / (180 \text{ W/m} \cdot \text{K} \times 0.01 \text{ m}) \right]^{1/2} = 27.50 \text{ m}^{-1}$   
 $mL_c = 27.50 \text{ m}^{-1} (0.055 \text{ m}) = 1.51$  and  $\tanh mL_c = 0.907$  Equation 3.94 yields  
 $\eta_f = \frac{\tanh mL_c}{mL_c} = \frac{0.907}{1.51} = 0.600$

Hence,

$$R_{t,o} = \left\{ 681 \text{ W/m}^2 \cdot \text{K} \times 0.070 \text{ m}^2 \left[ 1 - \frac{0.066 \text{ m}^2}{0.070 \text{ m}^2} (0.400) \right] \right\}^{-1} = 33.70 \times 10^{-3} \text{ K/W}$$

The conduction resistances are

$$R_{t,g} = \frac{L_g}{k_g A} = 3 \times 10^{-3} \text{ m} / (1.4 \text{ W/m} \cdot \text{K} \times 0.1 \text{ m} \times 0.1 \text{ m}) = 0.2143 \text{ K/W}$$

$$R_{t,a} = \frac{L_a}{k_a A} = 0.1 \times 10^{-3} \text{ m} / (145 \text{ W/m} \cdot \text{K} \times 0.1 \text{ m} \times 0.1 \text{ m}) = 6.897 \times 10^{-5} \text{ K/W}$$

$$R_{t,s} = \frac{L_s}{k_s A} = 0.1 \times 10^{-3} \text{ m} / (50 \text{ W/m} \cdot \text{K} \times 0.1 \text{ m} \times 0.1 \text{ m}) = 200 \times 10^{-6} \text{ K/W}$$

$$R_{t,an} = \frac{L_{an}}{k_{an} A} = 2 \times 10^{-3} \text{ m} / (120 \text{ W/m} \cdot \text{K} \times 0.1 \text{ m} \times 0.1 \text{ m}) = 1.67 \times 10^{-3} \text{ K/W}$$

$$R_{t,c} = \frac{R''_{t,c}}{A} = 0.5 \times 10^{-4} \text{ m}^2 \cdot \text{K/W} / (0.1 \text{ m} \times 0.1 \text{ m}) = 5.0 \times 10^{-3} \text{ K/W}$$

$$h_{\text{rad,top}} = \varepsilon_g \sigma (T_1 + T_{\text{sur}})(T_1^2 + T_{\text{sur}}^2)$$

$$R_{t,\text{rad,top}} = 1 / 0.9 \times 5.67 \times 10^{-8} \text{ W/m}^2 \cdot \text{K}^4 \times (T_1 + 298 \text{ K}) \times (T_1^2 + (298 \text{ K})^2) \quad (1)$$

The thermal circuit is

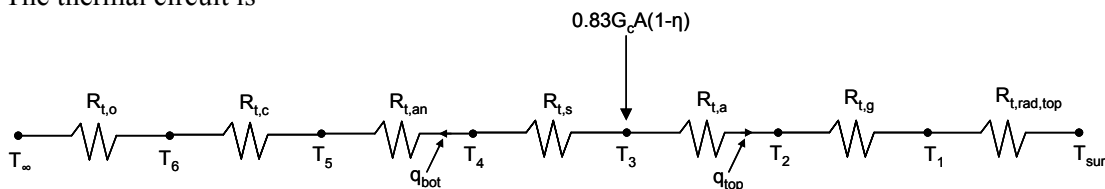

Continued...



### PROBLEM 7.30 (Cont.)

where  $G_c = G(L_{\text{lens}}/w_1)^2$

From the thermal circuit,

$$\begin{aligned} 0.83G (L_{\text{lens}}/w_1)^2 (w_1 \times w_2)(1 - \eta) &= q_{\text{top}} + q_{\text{bot}} \\ 0.83 \times 700 \text{ W/m}^2 (4)^2 (0.1 \text{ m} \times 0.1 \text{ m})(1 - \eta) &= q_{\text{top}} - q_{\text{bot}} \\ 92.96 \text{ W}(1 - \eta) &= q_{\text{top}} + q_{\text{bot}} \end{aligned} \quad (2)$$

$$\begin{aligned} q_{\text{top}} &= (T_3 - T_{\text{sur}}) / (R_{t,a} + R_{t,g} + R_{t,\text{rad,top}}) \\ &= (T_{\text{si}} - 298 \text{ K}) / \left( 6.897 \times 10^{-5} \text{ K/W} + 0.2143 \text{ K/W} + R_{t,\text{rad,top}} \right) \\ &= (T_{\text{si}} - 298 \text{ K}) / (0.2143 \text{ K/W} + R_{t,\text{rad,top}}) \end{aligned} \quad (3)$$

$$\begin{aligned} q_{\text{bot}} &= (T_3 - T_{\infty}) / (R_{t,o} + R_{t,c} + R_{t,\text{an}} + R_{t,s}) \\ &= (T_{\text{si}} - 298 \text{ K}) / \left( 33.70 \times 10^{-3} \text{ K/W} + 5.0 \times 10^{-3} \text{ K/W} + 1.67 \times 10^{-3} \text{ K/W} + 0.20 \times 10^{-3} \text{ K/W} \right) \\ &= (T_{\text{si}} - 298 \text{ K}) / (40.57 \times 10^{-3} \text{ K/W}) \end{aligned} \quad (4)$$

From the problem statement

$$\eta = 0.28 - 0.001^\circ\text{C}^{-1}(T_{\text{si}} - 273)^\circ\text{C} \quad (5)$$

Solving Equations (1) through (5) simultaneously yields

$$T_{\text{si}} = 28.2^\circ\text{C}, \quad \eta = 0.252 \quad <$$

The electric power is

$$P = 0.83G(L_{\text{lens}}/w_1)^2(w_1 \times w_2)(\eta) \quad (6)$$

$$P = 0.83 \times 700 \text{ W/m}^2 (4)^2 (0.1 \text{ m} \times 0.1 \text{ m})(0.252) = 23.4 \text{ W} \quad <$$

(b) Substituting  $L_{\text{lens}} = 1500 \text{ mm}$  in Equations 2 and 6 yields

$$T_{\text{si}} = 72.6^\circ\text{C}, \quad P = 271 \text{ W} \quad <$$

with the heat sink in place. For no heat sink we also substitute

$$R_{t,c} = 0 \text{ and } R_{t,o} = R_{t,\text{conv}} = 1/\bar{h}w_1^2 = 1/681 \text{ W/m}^2\cdot\text{K}(0.1\text{m})^2 = 146.8 \times 10^{-3} \text{ K/W}$$

into Equation 4 and solving Equations (1) through (5) simultaneously yields

Continued...

### PROBLEM 7.30 (Cont.)

$T_{si} = 200^\circ\text{C}$ ,  $P = 105\text{ W}$



(c) The variation of the silicon temperature and electric power with the heat sink in place is shown in the accompanying graphs.

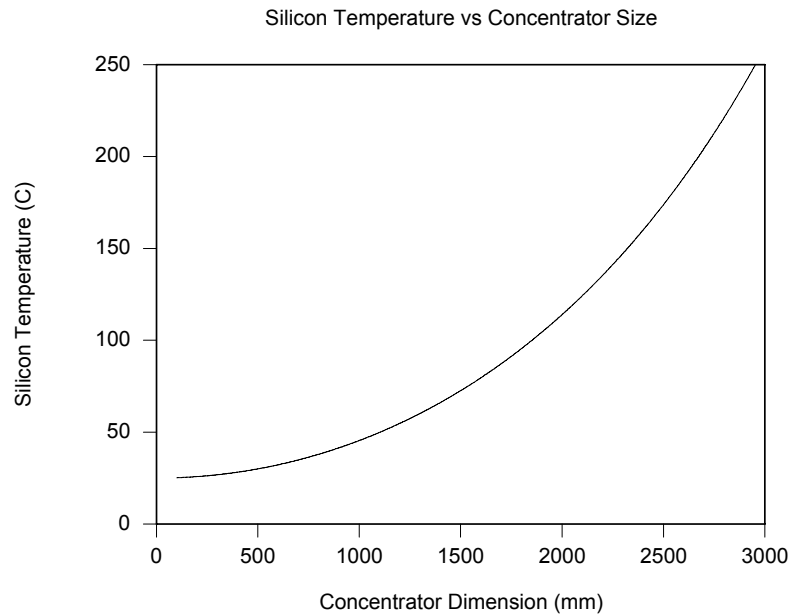
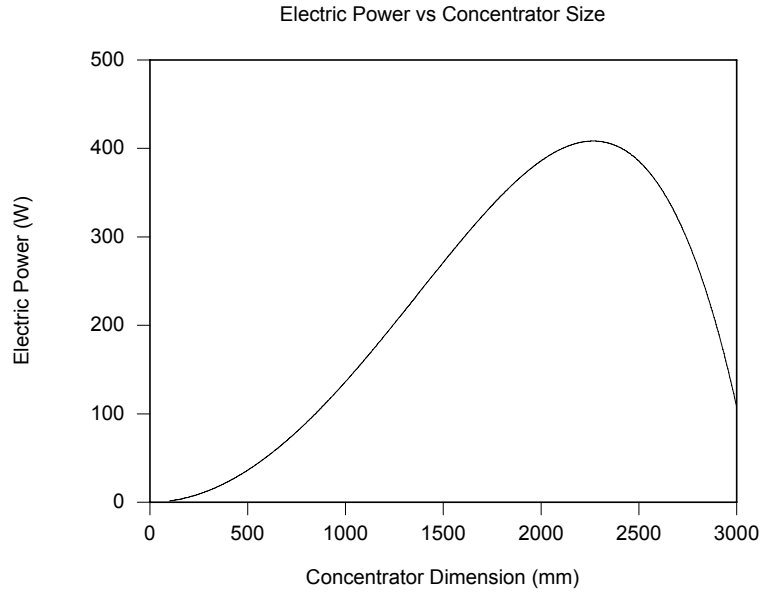

Continued...

### PROBLEM 7.30 (Cont.)

**COMMENTS:** (1) In Problem 7.19, we see that, for air cooling and  $L_{\text{lens}} = 400 \text{ mm}$ ,  $T_{\text{si}} = 126 \text{ }^\circ\text{C}$ ,  $P = 14.3 \text{ W}$ . Use of liquid cooling increases the electrical power output to  $23.4 \text{ W}$ , or 64 percent. In Problem 7.19 we see the maximum power output to be about  $15 \text{ W}$ . With liquid cooling and the heat sink, maximum power output increases to about  $420 \text{ W}$ , or 2800%. (2) The electric power is highly sensitive to the size of the concentrator. Initially, the power output increases as the concentrated irradiation increases, but as the silicon temperature increases the efficiency drops, driving the power output down. (3) The boundary layer thickness at the trailing edge of the fin is  $\delta = 5w_2/\text{Re}_{w_2}^{1/2} = 0.91 \text{ mm} \ll (S - t)$ . Also, since  $\text{Pr} > 1$ ,  $\delta_t < \delta$ . Hence, the assumption of parallel flow over a flat plate is reasonable. (4) The dielectric fluid outlet temperature may be calculated based the energy balance,  $q_{\text{bot}} = (T_{\text{si}} - 298 \text{ K})/(40.57 \times 10^{-3} \text{ K/W}) = 79 \text{ W} = \dot{m} c_p (T_{m,o} - T_{m,i})$  or  $T_{m,o} = 25^\circ\text{C} + 79 \text{ W}/(5 \times 0.008\text{m} \times 0.05\text{m} \times 3 \text{ m/s} \times 1400 \text{ kg/m}^3 \times 1300 \text{ J/kg}\cdot\text{K}) = 25.007^\circ\text{C}$  where there are  $N = 5$  channels. The assumption of constant dielectric mean temperature is excellent. (5) If the increase in the dielectric fluid temperature was significant, an approach described in Chapter 11 would be needed to analyze the problem. (6) Solar irradiation values can be nearly  $1100 \text{ W/m}^2$  in clear environments. How do you think the maximum electric power will change when the solar irradiation is increased? You may want to re-work the solution to the problem to find the surprising result.

### PROBLEM 7.31

**KNOWN:** Velocity, initial temperature, properties and dimensions of steel strip on a production line. Velocity and temperature of air in cross flow over top and bottom surfaces of strip. Temperature of surroundings.

**FIND:** (a) Differential equation governing temperature distribution along the strip, (b) Exact solution for negligible radiation and corresponding value of outlet temperature for prescribed conditions, (c) Effect of radiation on outlet temperature, and parametric effect of sheet velocity on temperature distribution.

**SCHEMATIC:**

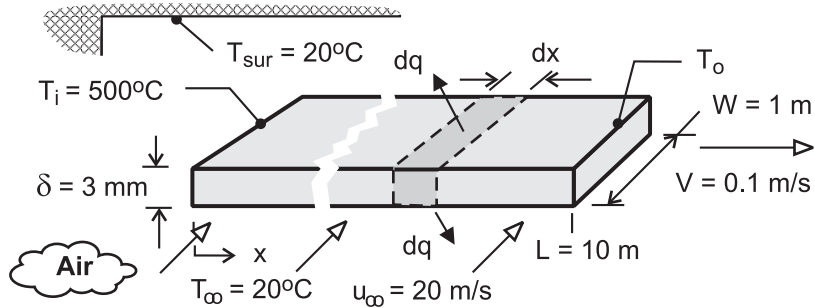

**ASSUMPTIONS:** (1) Negligible variation of sheet temperature across its width and thickness, (2) Negligible effect of conduction along length ( $x$ ) of sheet, (3) Constant properties, (4) Radiation exchange between small surface (both sides of sheet) and large surroundings, (5) Turbulent flow over top and bottom surfaces of sheet, (6) Motion of sheet has a negligible effect on the convection coefficient, ( $V \ll u_\infty$ ), (7) Negligible heat transfer from sides of sheet.

**PROPERTIES:** Prescribed. Steel:  $\rho = 7850 \text{ kg/m}^3$ ,  $c_p = 620 \text{ J/kg} \cdot \text{K}$ ,  $\varepsilon = 0.70$ . Air:  $k = 0.044 \text{ W/m} \cdot \text{K}$ ,  $\nu = 4.5 \times 10^{-5} \text{ m}^2/\text{s}$ ,  $\text{Pr} = 0.68$ .

**ANALYSIS:** (a) Applying conservation of energy to a stationary differential control surface, through which the sheet passes, conditions are steady and  $\dot{E}_{\text{in}} - \dot{E}_{\text{out}} = 0$ . Hence, with *inflow* due to *advection* and *outflow* due to *advection, convection* and *radiation*

$$\begin{aligned} \rho V A_c c_p T - \rho V A_c c_p (T + dT) - 2 dq &= 0 \\ -\rho V \delta W c_p dT - 2(W dx) \left[ \bar{h}_W (T - T_\infty) + \varepsilon \sigma (T^4 - T_{\text{sur}}^4) \right] &= 0 \\ \frac{dT}{dx} &= -\frac{2}{\rho V \delta c_p} \left[ \bar{h}_W (T - T_\infty) + \varepsilon \sigma (T^4 - T_{\text{sur}}^4) \right] \end{aligned} \quad (1) <$$

Alternatively, if the control surface is fixed to the sheet, conditions are transient and the energy balance is of the form,  $-\dot{E}_{\text{out}} = \dot{E}_{\text{st}}$ , or

$$\begin{aligned} -2(W dx) \left[ \bar{h}_W (T - T_\infty) + \varepsilon \sigma (T^4 - T_{\text{sur}}^4) \right] &= \rho (W \delta dx) c_p \frac{dT}{dt} \\ \frac{dT}{dt} &= -\frac{2}{\rho \delta c_p} \left[ \bar{h}_W (T - T_\infty) + \varepsilon \sigma (T^4 - T_{\text{sur}}^4) \right] \end{aligned}$$

Dividing the left- and right-hand sides of the equation by  $dx/dt$  and  $V = dx/dt$ , respectively, Eq. (1) is obtained.

(b) Neglecting radiation, separating variables and integrating, Eq. (1) becomes

$$\int_{T_i}^T \frac{dT}{T - T_\infty} = -\frac{2 \bar{h}_W}{\rho V \delta c_p} \int_0^x dx$$

Continued ...

**PROBLEM 7.31 (Cont.)**

$$\ln\left(\frac{T - T_\infty}{T_i - T_\infty}\right) = -\frac{2\bar{h}_W x}{\rho V \delta c_p}$$

$$T = T_\infty + (T_i - T_\infty) \exp\left(-\frac{2\bar{h}_W x}{\rho V \delta c_p}\right) \quad (2) <$$

With  $Re_W = u_\infty W / \nu = 20 \text{ m/s} \times 1\text{m} / 4 \times 10^{-5} \text{ m}^2/\text{s} = 5 \times 10^5$ , the correlation for turbulent flow over a flat plate yields

$$\overline{Nu}_W = 0.037 Re_W^{4/5} Pr^{1/3} = 0.037 (5 \times 10^5)^{4/5} (0.68)^{1/3} = 1179$$

$$\bar{h}_W = \frac{k}{W} \overline{Nu}_W = \frac{0.044 \text{ W/m} \cdot \text{K}}{1\text{m}} 1179 = 51.9 \text{ W/m}^2 \cdot \text{K}$$

Hence, applying Eq. (2) at  $x = L = 10\text{m}$ ,

$$T_o = 20^\circ\text{C} + (480^\circ\text{C}) \exp\left(-\frac{2 \times 51.9 \text{ W/m}^2 \cdot \text{K} \times 10\text{m}}{7850 \text{ kg/m}^3 \times 0.1 \text{ m/s} \times 0.003 \text{ m} \times 620 \text{ J/kg} \cdot \text{K}}\right) = 256^\circ\text{C} <$$

(c) Using the DER function of IHT, Eq. (1) may be numerically integrated from  $x = 0$  to  $x = L = 10\text{m}$  to obtain

$$T_o = 210^\circ\text{C} <$$

Contrasting this result with that of Part (b), it is clear that radiation makes a discernable contribution to cooling of the sheet. IHT was also used to determine the effect of the sheet velocity on the temperature distribution.

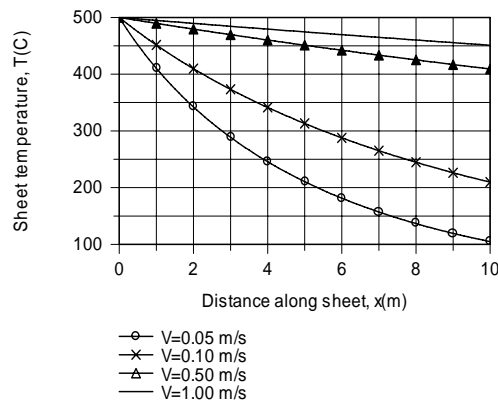

The sheet velocity has a significant influence on the temperature distribution. The temperature decay decreases with increasing  $V$  due to the increasing effect of advection on energy transfer in the  $x$  direction.

**COMMENTS:** (1) A critical parameter in the production process is the *coiling temperature*, that is, the temperature at which the wire may be safely coiled for subsequent storage or shipment. The larger the production rate ( $V$ ), the longer the cooling distance needed to achieve a desired coiling temperature. (2) Cooling may be enhanced by increasing the cross stream velocity  $u_\infty$ .

### PROBLEM 7.32

**KNOWN:** Length, thickness, speed and temperature of steel strip.

**FIND:** Rate of change of strip temperature 1 m from leading edge and at trailing edge. Location of minimum cooling rate.

**SCHEMATIC:**

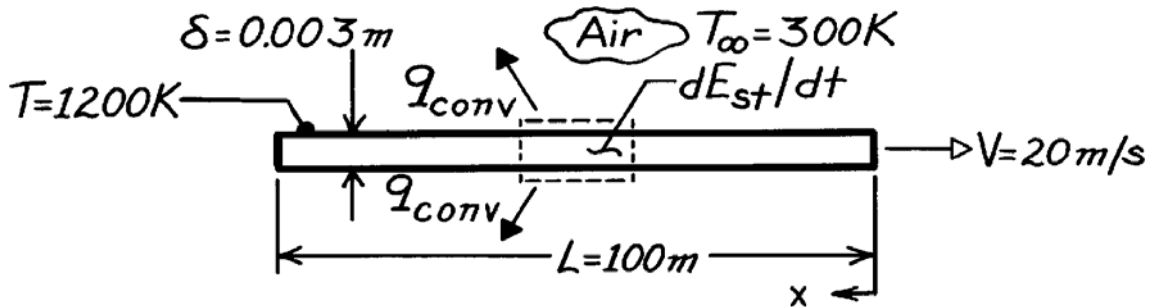

**ASSUMPTIONS:** (1) Constant properties, (2) Negligible radiation, (3) Negligible longitudinal conduction in strip, (4) Critical Reynolds number is  $5 \times 10^5$ .

**PROPERTIES:** Steel (given):  $\rho = 7900 \text{ kg/m}^3$ ,  $c_p = 640 \text{ J/kg}\cdot\text{K}$ . Table A-4, Air ( $\bar{T} = 750\text{K}$ , 1 atm):  $\nu = 76.4 \times 10^{-6} \text{ m}^2/\text{s}$ ,  $k = 0.0549 \text{ W/m}\cdot\text{K}$ ,  $\text{Pr} = 0.702$ .

**ANALYSIS:** Performing an energy balance for a control mass of unit surface area  $A_s$  riding with the strip,

$$-\dot{E}_{\text{out}} = dE_{\text{st}}/dt$$

$$-2h_x A_s (T - T_\infty) = \rho \delta A_s c_p (dT/dt)$$

$$dT/dt = \frac{-2h_x (T - T_\infty)}{\rho \delta c_p} = -\frac{2(900\text{K})h_x}{7900 \text{ kg/m}^3 (0.003 \text{ m}) 640 \text{ J/kg}\cdot\text{K}} = -0.119h_x \text{ (K/s)}.$$

$$\text{At } x = 1 \text{ m, } \text{Re}_x = \frac{Vx}{\nu} = \frac{20 \text{ m/s}(1\text{m})}{76.4 \times 10^{-6} \text{ m}^2/\text{s}} = 2.62 \times 10^5 < \text{Re}_{x,c}. \text{ Hence,}$$

$$h_x = (k/x) 0.332 \text{Re}_x^{1/2} \text{Pr}^{1/3} = \frac{0.0549 \text{ W/m}\cdot\text{K}}{1 \text{ m}} (0.332) (2.62 \times 10^5)^{1/2} (0.702)^{1/3} = 8.29 \text{ W/m}^2 \cdot \text{K}$$

$$\text{and at } x = 1 \text{ m, } dT/dt = -0.987 \text{ K/s.} \quad <$$

At the trailing edge,  $\text{Re}_x = 2.62 \times 10^7 > \text{Re}_{x,c}$ . Hence

$$h_x = (k/x) 0.0296 \text{Re}_x^{4/5} \text{Pr}^{1/3} = \frac{0.0549 \text{ W/m}\cdot\text{K}}{100 \text{ m}} (0.0296) (2.62 \times 10^7)^{4/5} (0.702)^{1/3} = 12.4 \text{ W/m}^2 \cdot \text{K}$$

$$\text{and at } x = 100 \text{ m, } dT/dt = -1.47 \text{ K/s.} \quad <$$

The minimum cooling rate occurs just before transition; hence, for  $\text{Re}_{x,c} = 5 \times 10^5$

$$x_c = 5 \times 10^5 (\nu/V) = \frac{5 \times 10^5 \times 76.4 \times 10^{-6} \text{ m}^2/\text{s}}{20 \text{ m/s}} = 1.91 \text{ m} \quad <$$

**COMMENTS:** The cooling rates are very low and would remain low even if radiation were considered. For this reason, hot strip metals are quenched by water and not by air.

### PROBLEM 7.33

**KNOWN:** Thin metallic strip with thermocouple at trailing edge is used as an anemometer. Laminar flow.

**FIND:** (a) Calibration equations for constant surface temperature and constant heat flux conditions. (b) Percentage error in using the wrong calibration. (c) Location of thermocouple for which calibration is insensitive to thermal boundary condition.

**SCHEMATIC:**

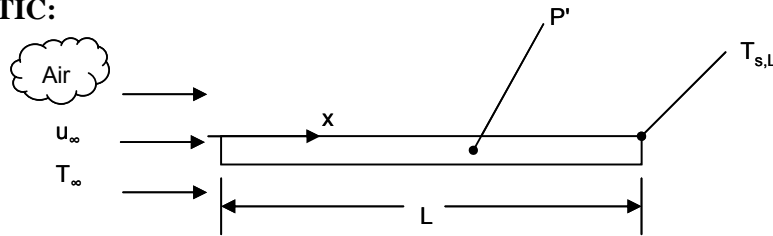

**ASSUMPTIONS:** (1) Steady-state conditions, (2) Boundary layer assumptions hold, (3) Laminar flow, (4) Constant properties.

**ANALYSIS:**

(a) For constant surface temperature

$$\overline{Nu}_L = 0.664 Re_L^{1/2} Pr^{1/3}$$

Therefore

$$\overline{h}_L = 0.664 Re_L^{1/2} Pr^{1/3} k/L$$

and 
$$P' = 2\overline{h}_L L (T_s - T_\infty) = 2 (0.664) \left(\frac{u_\infty L}{\nu}\right)^{1/2} Pr^{1/3} (T_s - T_\infty)$$

Solving for  $u_\infty$ , the calibration for constant  $T_s$  is:

$$u_\infty = \left\{ P' / \left[ 2 (0.664) Pr^{1/3} k (T_s - T_\infty) \right] \right\}^2 \left( \frac{\nu}{L} \right) \quad (1) <$$

For constant heat flux, we consider the local heat transfer coefficient at the end of the strip.

$$Nu_L = 0.453 Re_L^{1/2} Pr^{1/3}$$

$$h_L = 0.453 Re_L^{1/2} Pr^{1/3} k/L$$

Accounting for heat loss from both surfaces,

$$P' = 2q_s''L$$

The uniform heat flux can be related to the conditions at  $x = L$ :

$$q_s'' = h_L (T_{s,L} - T_\infty)$$

Thus

$$P' = 2h_L L (T_{s,L} - T_\infty) = 2 (0.453) \left(\frac{u_\infty L}{\nu}\right)^{1/2} Pr^{1/3} k (T_{s,L} - T_\infty)$$

Continued...

### PROBLEM 7.33 (Cont.)

Solving for  $u_\infty$ , the calibration for constant  $q_s''$  is:

$$u_\infty = \left\{ P' / \left[ 2 (0.453) \text{Pr}^{1/3} k (T_{s,L} - T_\infty) \right] \right\}^2 \left( \frac{\nu}{L} \right) \quad (2) <$$

(b) Since the true situation is uniform heat flux, the true velocity is found from Equation (2). However the predicted velocity is incorrectly calculated from Equation (1). Thus

$$\frac{u_{\infty, \text{pred.}}}{u_{\infty, \text{true}}} = \left( \frac{0.453}{0.664} \right)^2 = 0.47 \quad <$$

The velocity is underpredicted by more than half, or 53%.

(c) For constant surface heat flux, the local surface temperature is given by

$$T_{s,q}(x) - T_\infty = q_s'' / h_x = \frac{P'/2L}{0.453 \text{Re}_x^{1/2} \text{Pr}^{1/3} k/x}$$

where the  $q$  subscript on  $T_s$  indicates that it is for the constant heat flux case. This should be equal to the surface temperature for the constant  $T_s$  case, namely

$$T_{s,T} - T_\infty = P'/2L \bar{h}_L = \frac{P'/2L}{0.664 \text{Re}_L^{1/2} \text{Pr}^{1/3} k/L}$$

Equating  $T_{s,q}$  and  $T_{s,T}$  and solving for  $x$  yields

$$\begin{aligned} 0.453x^{-1/2} &= 0.664L^{-1/2} \\ (x/L) &= \left( \frac{0.453}{0.664} \right)^2 = 0.47 \quad < \end{aligned}$$

Thus, if the thermocouple is placed approximately at the midpoint of the strip it will be insensitive to the type of thermal boundary condition experienced by the strip.



## PROBLEM 7.34

**KNOWN:** Dimensions of flat plate in parallel flow. Plate and fluid temperatures, fluid velocities.

**FIND:** Average heat transfer coefficient, convection heat transfer rate, drag force for (a) water flowing at a velocity of 0.5 m/s, (b) nanofluid of Example 2.2 at a velocity of 0.5 m/s, (c) water at a velocity of 2.5 m/s, (d) nanofluid at a velocity of 2.5 m/s.

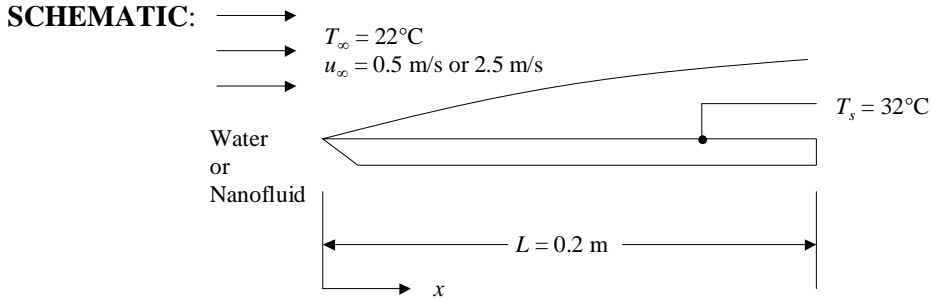

**ASSUMPTIONS:** (1) Steady-state conditions, (2) Constant properties,  $Re_{x,c} = 5 \times 10^5$ .

**PROPERTIES:** Table A.4, water (300 K):  $\rho_{bf} = 997 \text{ kg/m}^3$ ,  $\nu_{bf} = 857 \times 10^{-9} \text{ m}^2/\text{s}$ ,  $k_{bf} = 0.613 \text{ W/m}\cdot\text{K}$ ,  $Pr_{bf} = 5.83$ . Example 2.2, nanofluid (300 K):  $\rho_{nf} = 1146 \text{ kg/m}^3$ ,  $\mu_{nf} = 962 \times 10^{-6} \text{ m}^2/\text{s}$ ,  $\nu_{nf} = \mu_{nf}/\rho_{nf} = 839 \times 10^{-9} \text{ m}^2/\text{s}$ ,  $k_{nf} = 0.705 \text{ W/m}\cdot\text{K}$ ,  $\alpha_{nf} = 171 \times 10^{-9} \text{ m}^2/\text{s}$ ,  $Pr_{nf} = \nu_{nf}/\alpha_{nf} = 4.91$ .

**ANALYSIS:** (a) For water flowing over the plate at  $u_m = 0.5 \text{ m/s}$ ,

$$Re_L = \frac{u_\infty L}{\nu_{bf}} = \frac{0.5 \text{ m/s} \times 0.2 \text{ m}}{857 \times 10^{-9} \text{ m}^2/\text{s}} = 117 \times 10^3$$

Since  $Re_L < Re_{x,c}$  the flow is laminar and Eq. 7.30 yields

$$\bar{h}_L = \frac{k_{bf}}{L} \left[ 0.664 Re_L^{1/2} \right] Pr_{bf}^{1/3} = \frac{0.613 \text{ W/m}\cdot\text{K}}{0.2 \text{ m}} \left[ 0.664 \times 117,000^{1/2} \right] 5.83^{1/3} = 1253 \text{ W/m}^2\cdot\text{K} \quad <$$

and the convection heat transfer rate from the top of the plate is

$$q = wL\bar{h}_L(T_s - T_\infty) = 1 \text{ m} \times 0.2 \text{ m} \times 1253 \text{ W/m}^2\cdot\text{K} \cdot \text{K} \times (32 - 22)^\circ\text{C} = 2500 \text{ W} = 2.51 \text{ kW} \quad <$$

The drag force on the plate is

$$\begin{aligned} F &= \bar{\tau}_{s,L} wL = \frac{\bar{C}_f \rho_{bf} u_\infty^2}{2} wL \\ &= \frac{1.328 \rho_{bf} u_\infty^2}{2\sqrt{Re_L}} wL = \frac{1.328 \times 997 \text{ kg/m}^3 \times (0.5 \text{ m/s})^2}{2\sqrt{117 \times 10^3}} \times 1 \text{ m} \times 0.2 \text{ m} \\ &= 0.097 \text{ N} \quad < \end{aligned}$$

where Equation 7.29 has been used to determine the average friction coefficient.

Continued...

### PROBLEM 7.34 (Cont.)

(b) For the nanofluid flowing over the plate at  $u_m = 0.5$  m/s,

$$Re_L = \frac{u_\infty L}{\nu_{nf}} = \frac{0.5 \text{ m/s} \times 0.2 \text{ m}}{839 \times 10^{-9} \text{ m}^2/\text{s}} = 119 \times 10^3$$

The flow is laminar and Eq. 7.30 yields

$$\bar{h}_L = \frac{k_{nf}}{L} \left[ 0.664 Re_L^{1/2} \right] Pr_{nf}^{1/3} = \frac{0.705 \text{ W/m} \cdot \text{K}}{0.2 \text{ m}} \left[ 0.664 \times 119,000^{1/2} \right] 4.91^{1/3} = 1372 \text{ W/m}^2 \cdot \text{K} \quad <$$

and the convection heat transfer rate from the top of the plate is

$$q = wL\bar{h}_L(T_s - T_\infty) = 1 \text{ m} \times 0.2 \text{ m} \times 1372 \text{ W/m}^2 \cdot \text{K} (32 - 22)^\circ\text{C} = 2740 \text{ W} = 2.74 \text{ kW} \quad <$$

The drag force on the plate is

$$\begin{aligned} F &= \bar{\tau}_{s,L} wL = \frac{\bar{C}_f \rho_{nf} u_\infty^2}{2} wL \\ &= \frac{1.328 \rho_{nf} u_\infty^2}{2\sqrt{Re_L}} wL = \frac{1.328 \times 1146 \text{ kg/m}^3 \times (0.5 \text{ m/s})^2}{2\sqrt{119 \times 10^3}} \times 1 \text{ m} \times 0.2 \text{ m} \\ &= 0.110 \text{ N} \end{aligned} \quad <$$

(c) For water flowing over the plate at  $u_m = 2.5$  m/s,

$$Re_L = \frac{u_\infty L}{\nu_{bf}} = \frac{2.5 \text{ m/s} \times 0.2 \text{ m}}{857 \times 10^{-9} \text{ m}^2/\text{s}} = 5.83 \times 10^5$$

Therefore, the flow at the end of the plate is turbulent and Eq. 7.30 yields

$$\begin{aligned} \bar{h}_L &= \frac{k_{bf}}{L} \left[ 0.037 Re_L^{4/5} - 871 \right] Pr_{bf}^{1/3} \\ &= \frac{0.613 \text{ W/m} \cdot \text{K}}{0.2 \text{ m}} \left[ 0.037 (5.83 \times 10^5)^{4/5} - 871 \right] 5.83^{1/3} = 3562 \text{ W/m}^2 \cdot \text{K} \end{aligned} \quad <$$

and the convection heat transfer rate from the top of the plate is

$$q = wL\bar{h}_L(T_s - T_\infty) = 1 \text{ m} \times 0.2 \text{ m} \times 3562 \text{ W/m}^2 \cdot \text{K} (32 - 22)^\circ\text{C} = 7120 \text{ W} = 7.12 \text{ kW} \quad <$$

The drag force on the plate is

Continued...

### PROBLEM 7.34 (Cont.)

$$\begin{aligned} F &= \bar{\tau}_{s,L} wL = \bar{C}_f \frac{\rho_{\text{bf}} u_{\infty}^2}{2} wL \\ &= \left( 0.074 Re_L^{-1/5} - \frac{2 \times 871}{Re_L} \right) \frac{\rho_{\text{bf}} u_{\infty}^2}{2} wL \\ &= \left( 0.074 \times (5.83 \times 10^5)^{-1/5} - \frac{2 \times 871}{5.83 \times 10^5} \right) \frac{997 \text{ kg/m}^3 \times (2.5 \text{ m})^2}{2} \times 1 \text{ m} \times 0.2 \text{ m} \\ &= 1.379 \text{ N} \end{aligned} \quad <$$

where Equation 7.40 has been used to determine the average friction coefficient.

(d) For the nanofluid flowing over the plate at  $u_m = 2.5 \text{ m/s}$ ,  $Re_L = 5.96 \times 10^5$ ,  $\bar{h}_L = 4024 \text{ W/m}^2 \cdot \text{K}$ ,  $q = 8050 \text{ W} = 8.05 \text{ kW}$ , and  $F = 1.615 \text{ N}$ . <

**COMMENTS:** (1) The convection heat transfer rate is greater for the nanofluid than for the base fluid (water). For the laminar case, the nanofluid convection heat transfer rate is 9.5% larger when the nanofluid is used. For the turbulent flow case the convection heat transfer rate is 13% higher for the nanofluid. The higher efficacy of the nanofluid in the turbulent flow case is associated with its larger Reynolds number,  $Re_{L,\text{nf}} > Re_{L,\text{bf}}$ . Hence more of the plate experiences turbulent flow when the nanofluid is used. (2) The drag force is always greater when the nanofluid is used. For the laminar flow case, the drag force is 13.6% larger when the nanofluid is used, while for the turbulent flow case the drag force associated with the nanofluid is 17.1% larger than for the base fluid. Larger drag forces are expected due to the larger viscosity associated with the nanofluid. (c) For many cases involving nanofluids, a tradeoff exists between potentially increasing the heat transfer rates, but at a cost of experiencing larger friction losses.

### PROBLEM 7.35

**KNOWN:** Operating power of electrical components attached to one side of copper plate. Contact resistance. Velocity and temperature of water flow on opposite side.

**FIND:** (a) Plate temperature, (b) Component temperature.

**SCHEMATIC:**

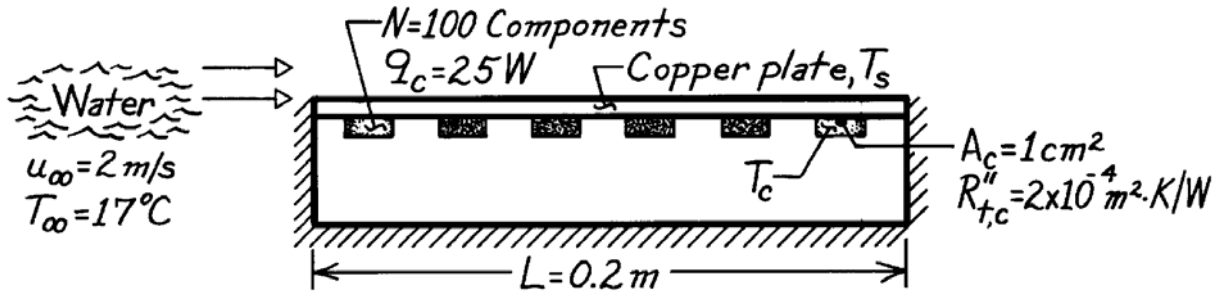

**ASSUMPTIONS:** (1) Steady-state conditions, (2) Constant properties, (3) Negligible heat loss from sides and bottom, (4) Turbulent flow throughout.

**PROPERTIES:** Water (given):  $\nu = 0.96 \times 10^{-6} \text{ m}^2/\text{s}$ ,  $k = 0.620 \text{ W/m}\cdot\text{K}$ ,  $\text{Pr} = 5.2$ .

**ANALYSIS:** (a) From the convection rate equation,

$$T_s = T_\infty + q/\bar{h}A$$

where  $q = Nq_c = 2500 \text{ W}$  and  $A = L^2 = 0.04 \text{ m}^2$ . The convection coefficient is given by the turbulent flow correlation

$$\bar{h} = \overline{\text{Nu}}_L (k/L) = 0.037 \text{Re}_L^{4/5} \text{Pr}^{1/3} (k/L)$$

where

$$\text{Re}_L = (u_\infty L / \nu) = (2 \text{ m/s} \times 0.2 \text{ m}) / 0.96 \times 10^{-6} \text{ m}^2/\text{s} = 4.17 \times 10^5$$

and hence

$$\bar{h} = 0.037 \left( 4.17 \times 10^5 \right)^{4/5} (5.2)^{1/3} (0.62 \text{ W/m}\cdot\text{K} / 0.2 \text{ m}) = 6228 \text{ W/m}^2 \cdot \text{K}.$$

The plate temperature is then

$$T_s = 17^\circ\text{C} + 2500 \text{ W} / \left( 6228 \text{ W/m}^2 \cdot \text{K} \right) (0.20 \text{ m})^2 = 27^\circ\text{C}. \quad <$$

(b) For an individual component, a rate equation involving the component's contact resistance can be used to find its temperature,

$$q_c = (T_c - T_s) / R_{t,c} = (T_c - T_s) / (R''_{t,c} / A_c)$$

$$T_c = T_s + q_c R''_{t,c} / A_c = 27^\circ\text{C} + 25 \text{ W} \left( 2 \times 10^{-4} \text{ m}^2 \cdot \text{K/W} \right) / 10^{-4} \text{ m}^2$$

$$T_c = 77^\circ\text{C}. \quad <$$

**COMMENTS:** With  $\text{Re}_L = 4.17 \times 10^5$ , the boundary layer would be laminar over the entire plate without the boundary layer trip, causing  $T_s$  and  $T_c$  to be appreciably larger.

### PROBLEM 7.36

**KNOWN:** Air at 27°C with velocity of 10 m/s flows turbulently over a series of electronic devices, each having dimensions of 4 mm × 4 mm and dissipating 40 mW.

**FIND:** (a) Surface temperature  $T_s$  of the fourth device located 15 mm from the leading edge, (b) Compute and plot the surface temperatures of the first four devices for the range  $5 \leq u_\infty \leq 15$  m/s, and (c) Minimum free stream velocity  $u_\infty$  if the surface temperature of the hottest device is not to exceed 80°C.

**SCHEMATIC:**

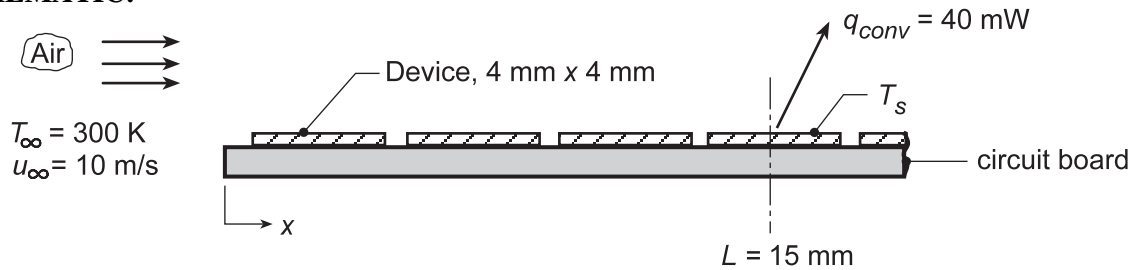

**ASSUMPTIONS:** (1) Turbulent flow, (2) Heat from devices leaving through top surface by convection only, (3) Device surface is isothermal, and (4) The average coefficient for the devices is equal to the local value at the mid position, i.e.  $\bar{h}_4 = h_x(L)$ .

**PROPERTIES:** Table A.4, Air (assume  $T_s = 330$  K,  $\bar{T} = (T_s + T_\infty)/2 = 315$  K, 1 atm):  $k = 0.0274$  W/m·K,  $\nu = 17.40 \times 10^{-6}$  m<sup>2</sup>/s,  $\alpha = 24.7 \times 10^{-6}$  m<sup>2</sup>/s,  $Pr = 0.705$ .

**ANALYSIS:** (a) From Newton's law of cooling,

$$T_s = T_\infty + q_{conv} / \bar{h}_4 A_s \quad (1)$$

where  $\bar{h}_4$  is the average heat transfer coefficient over the 4th device. Since flow is turbulent, it is reasonable and convenient to assume that

$$\bar{h}_4 = h_x(L = 15 \text{ mm}). \quad (2)$$

To estimate  $h_x$ , use the turbulent correlation evaluating thermophysical properties at  $\bar{T}_f = 315$  K (assume  $T_s = 330$  K),

$$Nu_x = 0.0296 Re_x^{4/5} Pr^{1/3}$$

where

$$Re_x = \frac{u_\infty L}{\nu} = \frac{10 \text{ m/s} \times 0.015 \text{ m}}{17.4 \times 10^{-6} \text{ m}^2/\text{s}} = 8621$$

giving

$$Nu_x = \frac{h_x L}{k} = 0.0296 (8621)^{4/5} (0.705)^{1/3} = 37.1$$

$$\bar{h}_4 = h_x = \frac{Nu_x k}{L} = \frac{37.1 \times 0.0274 \text{ W/m} \cdot \text{K}}{0.015 \text{ m}} = 67.8 \text{ W/m}^2 \cdot \text{K}$$

Hence, with  $A_s = 4 \text{ mm} \times 4 \text{ mm}$ , the surface temperature is

$$T_s = 300 \text{ K} + \frac{40 \times 10^{-3} \text{ W}}{67.8 \text{ W/m}^2 \cdot \text{K} \times (4 \times 10^{-3} \text{ m})^2} = 337 \text{ K} = 64^\circ \text{C}. \quad <$$

Continued...

### PROBLEM 7.36 (Cont.)

(b) The surface temperature for each of the four devices ( $i = 1, 2, 3, 4$ ) follows from Eq. (1),

$$T_{s,i} = T_{\infty} + q_{\text{conv}} / \bar{h}_i A_s \quad (3)$$

For devices 2, 3 and 4,  $\bar{h}_i$  is evaluated as the local coefficient at the mid-positions, Eq. (2),  $x_2 = 6.5$  mm,  $x_3 = 10.75$  mm and  $x_4 = 15$  mm. For device 1,  $\bar{h}_1$  is the average value 0 to  $x_1$ , where evaluated  $x_1 = L_1 = 4.25$  mm. Using Eq. (3) in the *IHT Workspace* along with the *Correlations Tool, External Flow, Local Coefficient for Laminar or Turbulent Flow*, the surface temperatures  $T_{s,i}$  are determined as a function of the free stream velocity.

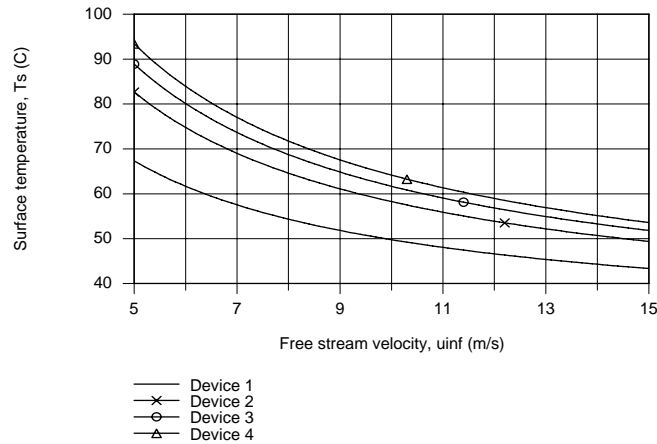

(c) Using the *Explore* option on the *Plot Window* associated with the IHT code of part (b), the minimum free stream velocity of

$$u_{\infty} = 6.6 \text{ m/s}$$

<

will maintain device 4, the hottest of the devices, at a temperature  $T_{s,4} = 80^{\circ}\text{C}$ .

**COMMENTS:** (1) Note that the thermophysical properties were evaluated at a reasonable assumed film temperature in part (a).

(2) From the  $T_{s,i}$  vs.  $u_{\infty}$  plots, note that, as expected, the surface temperatures of the devices increase with distance from the leading edge.

## PROBLEM 7.37

**KNOWN:** Length of isothermal flat plate in parallel flow,  $L$ .

**FIND:** Expression for the Reynolds number associated with the location of a trip wire to maximize heat transfer,  $Re_{x,c,opt}$ .

**SCHEMATIC:**

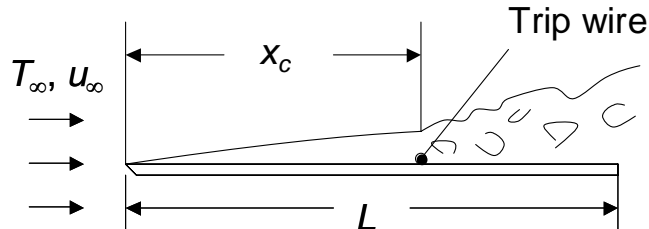

**ASSUMPTIONS:** (1) Constant properties.

**ANALYSIS:** From Equations 7.38 and 7.39

$$\overline{Nu}_L = \left(0.037 Re_L^{4/5} - A\right) Pr^{1/3} \quad \text{where} \quad A = 0.037 Re_{x,c}^{4/5} - 0.664 Re_{x,c}^{1/2} \quad (1a, b)$$

To maximize the average Nusselt number, it is necessary to minimize the value of  $A$ . Taking the derivative of  $A$  with respect to  $Re_{x,c}$  results in

$$\frac{dA}{dRe_{x,c}} = 0.037 \left(\frac{4}{5}\right) (Re_{x,c})^{-1/5} - 0.664 \left(\frac{1}{2}\right) (Re_{x,c})^{-1/2}$$

Setting  $dA/dRe_{x,c}$  equal to zero yields

$$Re_{x,c,opt}^{-1/5} Re_{x,c,opt}^{1/2} = \frac{0.664(1/2)}{0.037(4/5)} = 11.216$$

or  $Re_{x,c,opt} = 11.216^{(1/0.3)} = 3158$  <

**COMMENTS:** Substituting  $Re_{x,c,opt} = 3158$  into Equation 1b yields  $A_{opt} = -14$ . Since  $A = 0$  corresponds to tripping the boundary layer at the leading edge of the plate, and  $A = 871$  corresponds to a critical Reynolds number of  $Re_{x,c} = 5 \times 10^5$ , we know that placing the trip wire at an  $x$  location corresponding to  $Re_{x,c,opt} = 3158$  must maximize heat transfer from the plate (as opposed to minimizing heat transfer from the plate).

### PROBLEM 7.38

**KNOWN:** Convection correlation for irregular surface due to electronic elements mounted on a circuit board experiencing forced air cooling with prescribed temperature and velocity

**FIND:** Surface temperature when heat dissipation rate is 30 mW for chip of prescribed area located a specific distance from the leading edge.

**SCHEMATIC:**

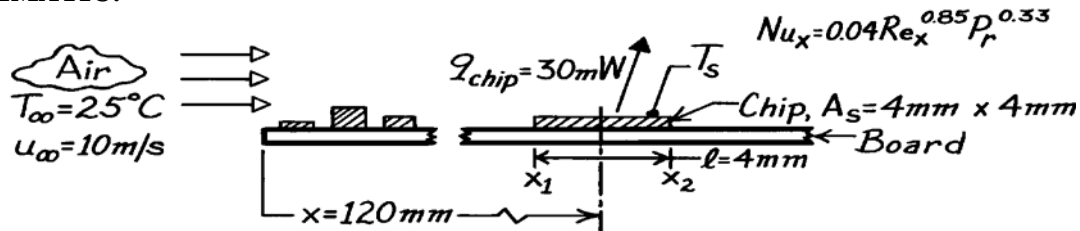

**ASSUMPTIONS:** (1) Situation approximates parallel flow over a flat plate with prescribed correlation, (2) Heat rate is from top surface of chip.

**PROPERTIES:** Table A-4, Air (assume  $T_s \approx 45^\circ\text{C}$ , then  $\bar{T} = (45 + 25)^\circ\text{C}/2 \approx 310\text{ K}$ , 1 atm):  $k = 0.027\text{ W/m}\cdot\text{K}$ ,  $\nu = 16.90 \times 10^{-6}\text{ m}^2/\text{s}$ ,  $\text{Pr} = 0.706$ .

**ANALYSIS:** For the chip upper surface, the heat rate is

$$q_{\text{chip}} = \bar{h}_{\text{chip}} A_s (T_s - T_\infty) \quad \text{or} \quad T_s = T_\infty + q_{\text{chip}} / \bar{h}_{\text{chip}} A_s$$

Assuming the average convection coefficient over the chip length to be equal to the local value at the center of the chip ( $x = x_0$ ),  $\bar{h}_{\text{chip}} \approx h_x(x_0)$ , where

$$\text{Nu}_x = 0.04 \text{Re}_x^{0.85} \text{Pr}^{0.33}$$

$$\text{Nu}_x = 0.04 \left( 10\text{ m/s} \times 0.120\text{ m} / 16.90 \times 10^{-6}\text{ m}^2/\text{s} \right)^{0.85} (0.706)^{0.33} = 473.4$$

$$h_x = \frac{\text{Nu}_x k}{x_0} = \frac{473.4 \times 0.027\text{ W/m}\cdot\text{K}}{0.120\text{ m}} = 107\text{ W/m}^2 \cdot \text{K}$$

Hence,

$$T_s = 25^\circ\text{C} + 30 \times 10^{-3}\text{ W} / 107\text{ W/m}^2 \cdot \text{K} \times \left( 4 \times 10^{-3}\text{ m} \right)^2 = (25 + 17.5)^\circ\text{C} = 42.5^\circ\text{C}. <$$

**COMMENTS:** (1) Note that the assumed value of  $\bar{T}$  used to evaluate the thermophysical properties was reasonable. (2) We could have evaluated  $\bar{h}_{\text{chip}}$  by two other approaches. In one case the average coefficient is approximated as the arithmetic mean of local values at the leading and trailing edges of the chip.

$$\bar{h}_{\text{chip}} \approx [h_{x2}(x_2) + h_{x1}(x_1)] / 2 = 107\text{ W/m}^2 \cdot \text{K}.$$

The exact approach is of the form

$$\bar{h}_{\text{chip}} \cdot \ell = \bar{h}_{x2} \cdot x_2 - \bar{h}_{x1} \cdot x_1$$

Recognizing that  $h_x \sim x^{-0.15}$ , it follows that

$$\bar{h}_x = \frac{1}{x} \int_0^x h_x \cdot dx = 1.176 h_x$$

and  $\bar{h}_{\text{chip}} = 108\text{ W/m}^2 \cdot \text{K}$ . Why do results for the two approximate methods and the exact method compare so favorably?



### PROBLEM 7.39

**KNOWN:** Air at atmospheric pressure and a temperature of 25°C in parallel flow at a velocity of 5 m/s over a 1-m long flat plate with a uniform heat flux of 1250 W/m<sup>2</sup>.

**FIND:** (a) Plate surface temperature,  $T_s(L)$ , and local convection coefficient,  $h_x(L)$ , at the trailing edge,  $x = L$ , (b) Average temperature of the plate surface,  $\bar{T}_s$ , (c) Plot the variation of the plate surface temperature,  $T_s(x)$ , and the convection coefficient,  $h_x(x)$ , with distance on the same graph; explain key features of these distributions.

**SCHEMATIC:**

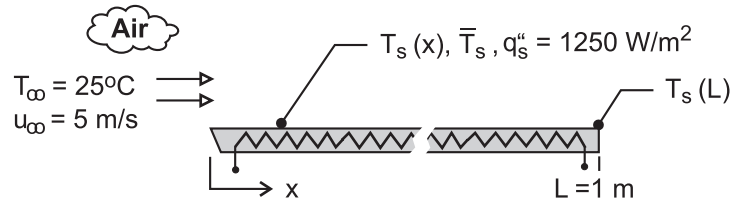

**ASSUMPTIONS:** (1) Steady-state conditions, (2) Flow is fully turbulent, and (3) Constant properties.

**PROPERTIES:** Table A-4, Air (assume  $T_f = 325$  K, 1 atm):  $\nu = 18.76 \times 10^{-6}$  m<sup>2</sup>/s;  $k = 0.0284$  W/m·K;  $Pr = 0.703$ .

**ANALYSIS:** (a) At the trailing edge,  $x = L$ , the convection rate equation is

$$q_s'' = q_{cv}'' = h_x(L) [T_s(L) - T_\infty] \quad (1)$$

where the local convection coefficient, assuming turbulent flow, follows from Eq. 7.46.

$$Nu_x = \frac{h_x x}{k} = 0.0308 Re_x^{4/5} Pr^{1/3} \quad (2)$$

With  $x = L = 1$  m, find

$$Re_x = u_\infty L / \nu = 5 \text{ m/s} \times 1 \text{ m} / 18.76 \times 10^{-6} \text{ m}^2/\text{s} = 2.67 \times 10^5$$

$$h_x(L) = (0.0284 \text{ W/m} \cdot \text{K} / 1 \text{ m}) \times 0.0308 \left( 2.67 \times 10^5 \right)^{4/5} (0.703)^{1/3} = 17.1 \text{ W/m}^2 \cdot \text{K}$$

Substituting numerical values into Eq. (1),

$$T_s(L) = 25^\circ\text{C} + 1250 \text{ W/m}^2 / 17.1 \text{ W/m}^2 \cdot \text{K} = 98.3^\circ\text{C} \quad <$$

(b) The average surface temperature  $\bar{T}_s$  follows from the expression

$$\bar{T}_s - T_\infty = \frac{1}{L} \int_0^L (T_s - T_\infty) dx = \frac{q_s''}{L} \int_0^L \frac{x}{k Nu_x} dx \quad (3)$$

where  $Nu_x$  is given by Eq. (2). Using the *Integral* function in *IHT* as described in Comment (3) find

$$\bar{T}_s = 86.1^\circ\text{C}. \quad <$$

(c) The variation of the plate surface temperature  $T_s(x)$  and convection coefficient,  $h_x(x)$ , shown in the graph are calculated using Eqs. (1) and (2).

Continued ...

### PROBLEM 7.39 (Cont.)

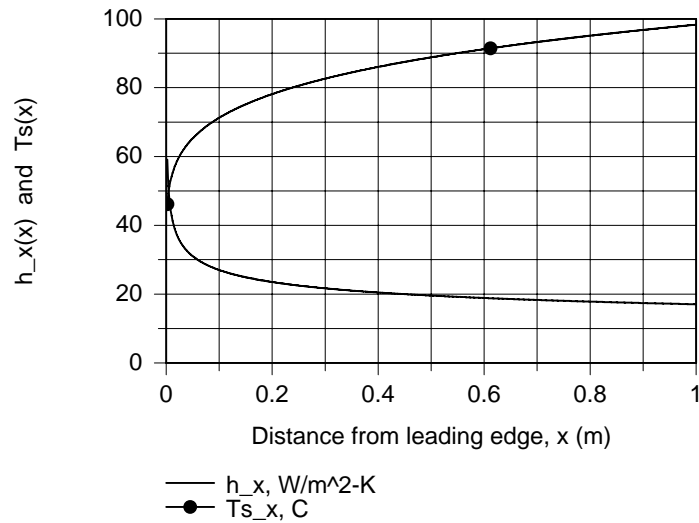

**COMMENTS:** (1) The properties for the correlation should be evaluated at  $T_f = (\bar{T}_s + T_\infty)/2$ .

From the foregoing analyses,  $T_f = (86.1 + 25)^\circ/2 = 55.5^\circ\text{C} = 329\text{ K}$ . Hence, the assumed value of 325 K was reasonable.

(2) The IHT code, excluding the input variables and air property functions, used to evaluate the integral of Eq. (3) and generate the graphs in part (c) is shown below.

```
/* Programming note: when using the INTEGRAL function, the value of the independent variable
must not be specified as an input variable. If done so, this error message will appear:
"Redefinition of a constant variable." */
```

```
// Turbulent flow correlation, Eq. 7.45, local values
```

```
Nu_x = 0.0308 * Re_x^0.8 * Pr^0.333
```

```
Nu_x = h_x * x / k
```

```
Re_x = uinf * x / nu
```

```
// Plate temperatures
```

```
// Local
```

```
Ts_x = Tinf + q"s / h_x
```

```
// Average
```

```
Ts_avg - Tinf = q"s / L * INTEGRAL (y,x)
```

```
delT_avg = Ts_avg - Tinf
```

```
y = x / (k * Nu_x)
```

## PROBLEM 7.40

**KNOWN:** Experimental apparatus providing nearly uniform airstream over a flat *test plate*. Temperature history of the pre-heated plate for airstream velocities of 3 and 9 m/s were fitted to a fourth-order polynomial.

**FIND:** (a) Convection coefficient for the two cases assuming the plate behaves as a spacewise isothermal object and (b) Coefficients C and m for a correlation of the form  $\overline{Nu}_L = C Re^m Pr^{1/3}$ ; compare result with a standard-plate correlation and comment on the goodness of the comparison; explain any differences.

**SCHEMATIC:**

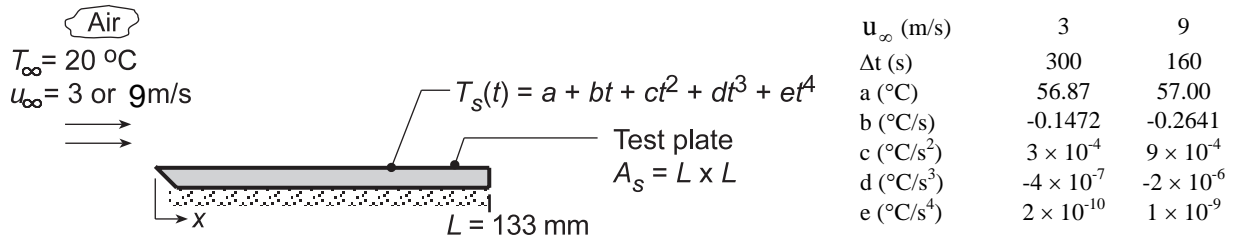

**ASSUMPTIONS:** (1) Airstream over the *test plate* approximates parallel flow over a flat plate, (2) Plate is spacewise isothermal, (3) Negligible radiation exchange between plate and surroundings, (4) Constant properties, and (5) Negligible heat loss from the bottom surface or edges of the test plate.

**PROPERTIES:** Table A.4, Air ( $T_f = (T_s + T_\infty)/2 \approx 310$  K, 1 atm):  $k_a = 0.0269$  W/m·K,  $\nu = 1.669 \times 10^{-5}$  m<sup>2</sup>/s,  $Pr = 0.706$ . Test plate (Given):  $\rho = 2770$  kg/m<sup>3</sup>,  $c_p = 875$  J/kg·K,  $k = 177$  W/m·K.

**ANALYSIS:** (a) Using the lumped-capacitance method, the energy balance on the plate is

$$-\bar{h}_L A_s [T_s(t) - T_\infty] = \rho V c_p \frac{dT}{dt} \quad (1)$$

and the average convection coefficient can be determined from the temperature history,  $T_s(t)$ ,

$$\bar{h}_L = \frac{\rho V c_p}{A_s} \frac{(dT/dt)}{T_s(t) - T_\infty} \quad (2)$$

where the temperature-time derivative is

$$\frac{dT_s}{dt} = b + 2ct + 3dt^2 + 4et^3 \quad (3)$$

The temperature time history plotted below shows the experimental behavior of the observed data.

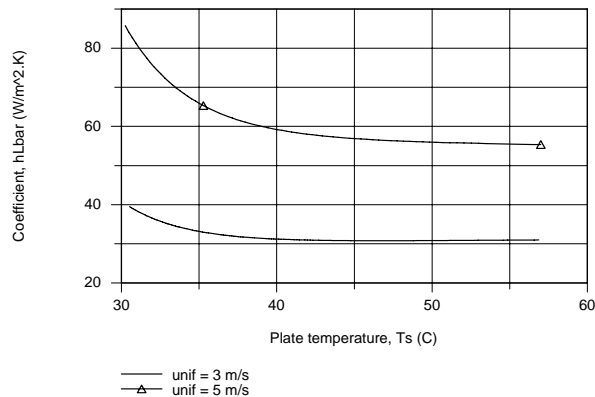

Continued...

### PROBLEM 7.40 (Cont.)

Consider now the integrated form of the energy balance, Eq. (5.6), expressed as

$$\ln \frac{T_s(t) - T_\infty}{T_i - T_\infty} = - \left( \frac{\bar{h}_L A_s}{\rho V c} \right) t \quad (4)$$

If we were to plot the LHS vs  $t$ , the slope of the curve would be proportional to  $\bar{h}_L$ . Using IHT, plots were generated of  $\bar{h}_L$  vs.  $T_s$ , Eq. (1), and  $\ln \left[ (T_s(t) - T_\infty) / (T_i - T_\infty) \right]$  vs.  $t$ , Eq. (4). From the latter plot, recognize that the regions where the slope is constant corresponds to early times ( $\leq 100$ s when  $u_\infty = 3$  m/s and  $\leq 50$ s when  $u_\infty = 5$  m/s).

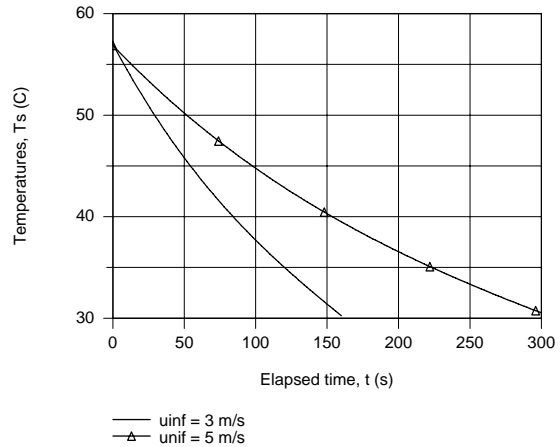
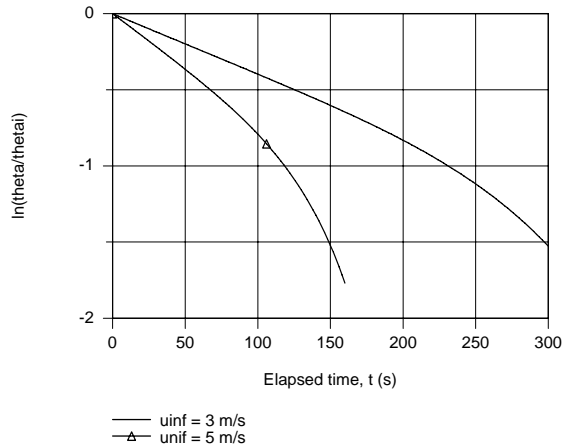

Selecting two elapsed times at which to evaluate  $\bar{h}_L$ , the following results were obtained

$u_\infty$ (m/s)	$t$ (s)	$T_s(t)$ , ( $^\circ\text{C}$ )	$\bar{h}_L$ ( $\text{W}/\text{m}^2 \cdot \text{K}$ )	$\overline{\text{Nu}}_L$	$\text{Re}_L$
3	100	44.77	30.81	152.4	$2.39 \times 10^4$
9	50	45.80	56.7	280.4	$7.17 \times 10^4$

where the dimensionless parameters are evaluated as

$$\overline{\text{Nu}}_L = \frac{\bar{h}_L L}{k_a} \quad \text{Re}_L = \frac{u_\infty L}{\nu} \quad (5,6)$$

where  $k_a$ ,  $\nu$  are thermophysical properties of the airstream.

(b) Using the above pairs of  $\overline{\text{Nu}}_L$  and  $\text{Re}_L$ ,  $C$  and  $m$  in the correlation can be evaluated,

$$\overline{\text{Nu}}_L = C \text{Re}_L^m \text{Pr}^{1/3} \quad (7)$$

$$152.4 = C(2.39 \times 10^4)^m (0.706)^{1/3}$$

$$280.4 = C(7.17 \times 10^4)^m (0.706)^{1/3}$$

Solving, find

$$C = 0.633 \quad m = 0.555 \quad (8,9) <$$

Continued...

### PROBLEM 7.40 (Cont.)

The plot below compares the experimental correlation ( $C = 0.633$ ,  $m = 0.555$ ) with those for laminar flow ( $C = 0.664$ ,  $m = 0.5$ ) and fully turbulent flow ( $C = 0.037$ ,  $m = 0.8$ ). The experimental correlation yields  $\overline{Nu}_L$  values which are 25% higher than for the correlation. The most likely explanation for this unexpected trend is that the airstream reaching the plate is not parallel, but with a slight impingement effect and/or the flow is very highly turbulent at the leading edge.

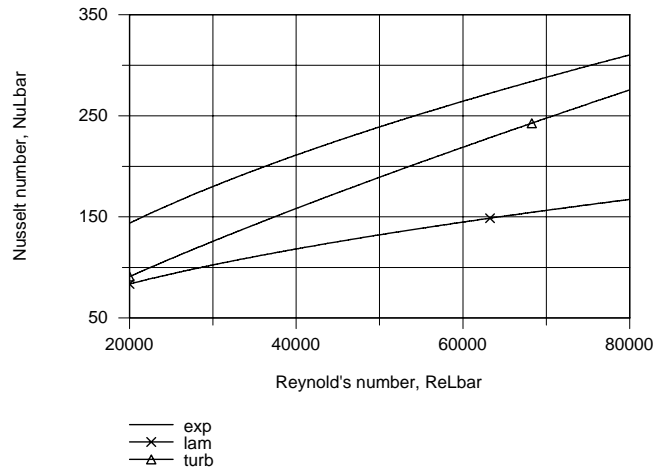

**COMMENTS:** (1) A more extensive analysis of the experimental observations would involve determining  $\overline{Nu}_L$  for the full range of elapsed time (rather than at two selected times) and using a fitting routine to determine values for  $C$  and  $m$ .

## PROBLEM 7.41

**KNOWN:** Conditions for airflow over isothermal plate with optional unheated starting length.

**FIND:** (a) local coefficient,  $h_x$ , at leading and trailing edges with and without an unheated starting length,  $\xi = 1$  m.

**SCHEMATIC:**

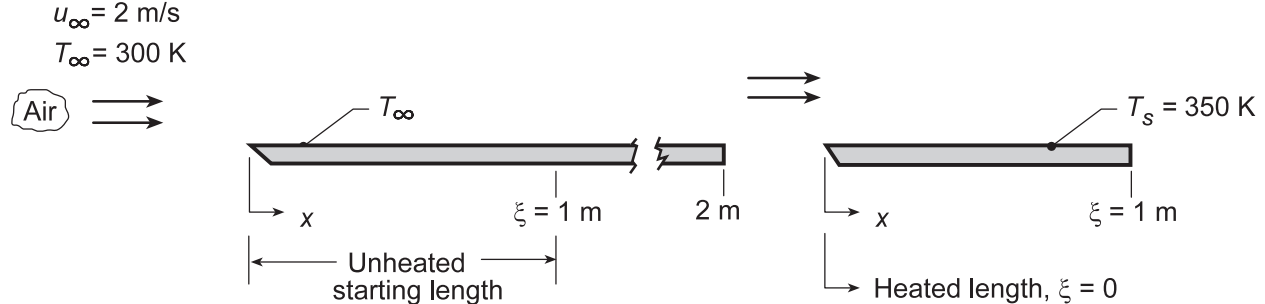

**PROPERTIES:** Table A.4, Air ( $T_f = 325$  K, 1 atm):  $\nu = 18.4 \times 10^{-6}$  m<sup>2</sup>/s, Pr = 0.703,  $k = 0.0282$  W/m·K.

**ANALYSIS:** (a) The Reynolds number at  $\xi = 1$  m is

$$Re_\xi = \frac{u_\infty \xi}{\nu} = \frac{2 \text{ m/s} \times 1 \text{ m}}{18.4 \times 10^{-6} \text{ m}^2/\text{s}} = 1.087 \times 10^5$$

If  $Re_{x,c} = 5 \times 10^5$ , flow is laminar over the entire plate (with or without the starting length). In general,

$$Nu_x = \frac{0.332 Re_x^{1/2} Pr^{1/3}}{\left[1 - (\xi/x)^{3/4}\right]^{1/3}} \quad (1)$$

$$h_x = \frac{(0.332k Pr^{1/3}) Re_x^{1/2}}{x \left[1 - (\xi/x)^{3/4}\right]^{1/3}} = 0.00832 \text{ W/m} \cdot \text{K} \frac{Re_x^{1/2}}{x \left[1 - (\xi/x)^{3/4}\right]^{1/3}}$$

*With Unheated Starting Length:* Leading edge ( $x = 1$  m):  $Re_x = Re_\xi$ ,  $\xi/x = 1$ ,  $h_x = \infty$  <

Trailing Edge ( $x = 2$  m):  $Re_x = 2 Re_\xi = 2.17 \times 10^5$ ,  $\xi/x = 0.5$

$$h_x = 0.00832 \text{ W/m} \cdot \text{K} \frac{(2.17 \times 10^5)^{1/2}}{2 \text{ m} \left[1 - (0.5)^{3/4}\right]^{1/3}} = 2.61 \text{ W/m}^2 \cdot \text{K} \quad <$$

*Without Unheated Starting Length:* Leading edge ( $x = 0$ ):  $h_x = \infty$  <

Trailing edge ( $x = 1$  m):  $Re_x = 1.087 \times 10^5$

$$h_x = 0.00832 \text{ W/m} \cdot \text{K} \frac{(1.087 \times 10^5)^{1/2}}{1 \text{ m}} = 2.74 \text{ W/m}^2 \cdot \text{K} \quad <$$

(b) The average convection coefficient  $\bar{h}_L$  for the two cases in the schematic are, from Eq. 6.14,

Continued...

### PROBLEM 7.41 (Cont.)

$$\bar{h}_L = \frac{1}{L} \int_0^L h_x(x) dx \quad (2)$$

where L is the x location at the end of the heated section. Substituting Eq. (1) into Eq. (2) and numerically integrating, the results are tabulated below:

$\xi$ (m)	$h_x(L)$ (W/m <sup>2</sup> ·K)	$\bar{h}_L$ (W/m <sup>2</sup> ·K)
0	2.74	5.41
1	2.61	4.22

(c) The variation of the local convection coefficient over the plate, with and without the unheated starting length, using Eq. (1) is shown below. The abscissa is  $x - \xi$ .

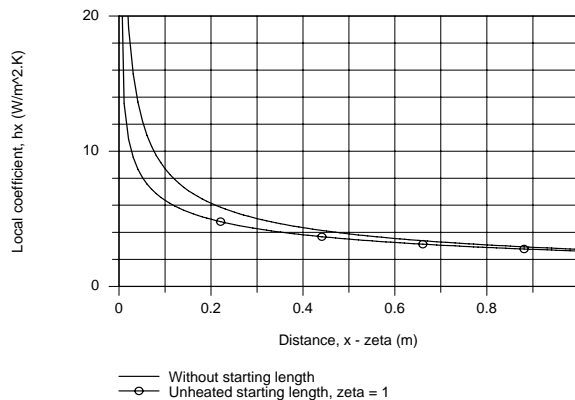

**COMMENTS:** (1) When the velocity and thermal boundary layers grow simultaneously (*without starting length*), we expect the local and average coefficients to be larger than when the velocity boundary layer is thicker (*with starting length*).

(2) When  $\xi = 0$ ,  $\bar{h}_L = 2h_L$ , when  $\xi = 1$ ,  $\bar{h}_L < 2h_L$ . From Eq. (7.44),  $\bar{h}_L = 4.25 \text{ W/m}^2 \cdot \text{K}$ .

(3) The numerical integration of Eq. (2) was performed using the INTEGRAL (f,x) operation in IHT as shown in the Workspace below.

**// Average Coefficient:**

```
hbarL = 1 / (L - zeta) * INTEGRAL (hx,x)
```

**// Local Coefficient With Unheated Starting Length:**

```
hx = (k / x) * 0.332 * Rex^0.5 * Pr^0.3333 / (1 - (zeta / x)^(3/4))^(1/3)
Rex = uinf * x / nu
```

**// Properties Tool - Air:**

```
// Air property functions : From Table A.4
// Units: T(K); 1 atm pressure
nu = nu_T("Air",Tf) // Kinematic viscosity, m^2/s
k = k_T("Air",Tf) // Thermal conductivity, W/m-K
Pr = Pr_T("Air",Tf) // Prandtl number
Tf = 325 // Film temperature, K
```

**// Assigned Variables:**

```
uinf = 2 // Airstream velocity, m/s
x = 1 // Distance from leading edge, m
L = 2 // Full length of plate, m
zeta = 1 // Starting length, m
xzeta = x - zeta // Difference
```

## PROBLEM 7.42

**KNOWN:** Dimensions of thin fuel cell in parallel flow. Ambient and surroundings temperatures, fuel cell emissivity, desired fuel cell operating temperature. Fuel cell thermal generation rate.

**FIND:** Minimum velocity needed to sustain desired fuel cell temperature.

**SCHEMATIC:**

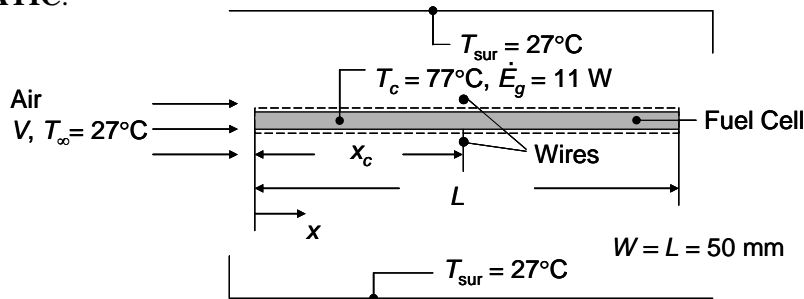

**ASSUMPTIONS:** (1) Steady-state conditions, (2) Negligible temperature variations inside the fuel cell, (3) Large surroundings, (4) Insulated fuel cell edges, (5) Negligible energy entering or leaving the fuel cell due to gas or liquid flows, (6), Constant properties, (7) Isothermal fuel cell, (8) Trip wire causes laminar-to-turbulent transition.

**PROPERTIES:** Table A.4, air ( $T_f = (77^\circ\text{C} + 27^\circ\text{C})/2 = 52^\circ\text{C} = 325\text{K}$ ,  $p = 1\text{ atm}$ ):  $\nu = 18.4 \times 10^{-6}\text{ m}^2/\text{s}$ ,  $Pr = 0.704$ ,  $k = 0.0282\text{ W/m}\cdot\text{K}$ .

**ANALYSIS:** An energy balance on the control volume yields  $\dot{E}_g = q_{\text{rad}} + q_{\text{cv}}$  or

$$\begin{aligned} q_{\text{cv}} &= \dot{E}_g - 2LW\varepsilon\sigma(T_c^4 - T_{\text{sur}}^4) \\ &= 11\text{W} - 2 \times (50 \times 10^{-3}\text{m})^2 \times 0.85 \times 5.67 \times 10^{-8}\text{W/m}^2 \cdot \text{K}^4 \times \left[ (273 + 77\text{K})^4 - (273 + 27\text{K})^4 \right] \\ &= 9.34\text{W} \end{aligned}$$

Applying Newton's law of cooling yields

$$\bar{h} = \frac{q_{\text{cv}}}{2LW(T_c - T_\infty)} = \frac{9.34\text{W}}{2 \times (50 \times 10^{-3}\text{m})^2 \times (77 - 27)^\circ\text{C}} = 37.4\text{W/m}^2 \cdot \text{K}$$

Since the flow may transition at the location of the trip wire, Eqs. (7.38) and (7.39) may be applied, yielding

$$\bar{h} = \frac{0.0282\text{W/m}\cdot\text{K}}{0.050\text{m}} \left( 0.037Re_L^{4/5} - 0.037Re_{x,c}^{4/5} + 0.664Re_{x,c}^{1/2} \right) 0.704^{1/3} = 37.4\text{W/m}^2 \cdot \text{K}$$

where  $Re_L = VL/\nu = V \times 0.050\text{m}/18.4 \times 10^{-6}\text{m}^2/\text{s}$  and  $Re_{x,c} = Vx_c/\nu = Vx_c/18.4 \times 10^{-6}\text{m}^2/\text{s}$

The preceding three equations may be solved for the free stream velocity,  $V$ , for various trip wire locations,  $x_c$ . The results are shown in the following graph. From the graph, we note that the minimum air velocity is approximately  $V_{\text{min}} = 3.84\text{ m/s}$  with a trip wire location of  $x_c = 15\text{ mm}$ .

<  
Continued...



### PROBLEM 7.42 (Cont.)

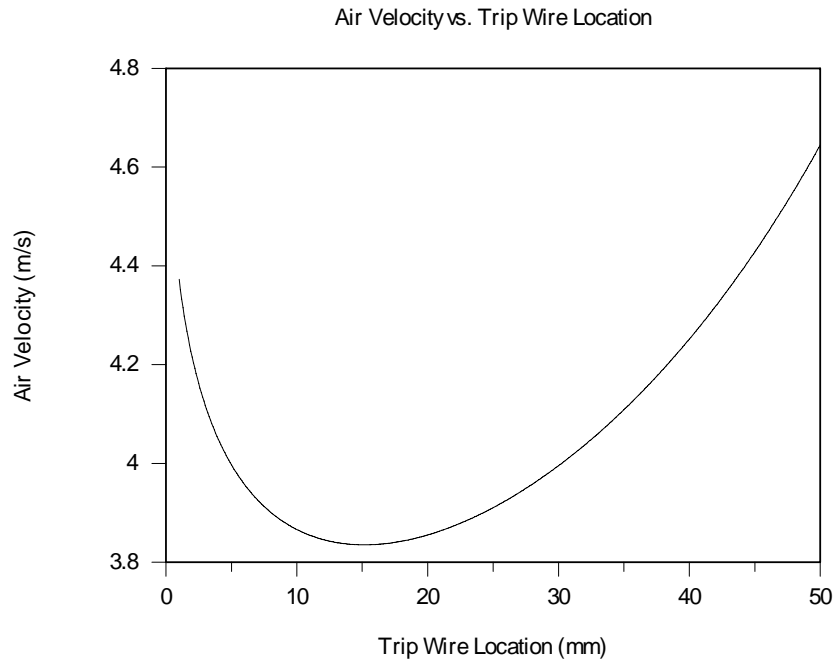

**COMMENTS:** (1) The optimal trip wire location takes advantage of the very high local Nusselt numbers associated with very thin laminar boundary layers near the leading edge of the fuel cell. Once the local Nusselt numbers within the laminar section begin to decrease, the flow is tripped to take advantage of the increased local Nusselt numbers of turbulent boundary layers. Hence, an optimum trip wire location exists. (2) The *maximum* Reynolds number based upon the fuel cell length and a maximum velocity of approximately  $V_{\max} = 4.65 \text{ m/s}$  is  $Re_{\max,L} = 4.65 \text{ m/s} \times 0.050 \text{ m} / 18.4 \times 10^{-6} \text{ m}^2/\text{s} = 12,630$ . This is far below the typical transition Reynolds number of 500,000, and the flow will be laminar if it is not tripped into a turbulent condition. (3) The reduction in the air velocity associated with placement of the trip wires is significant and will result in substantially reduced power requirements to operate the cooling fan.

### PROBLEM 7.43

**KNOWN:** Cover plate dimensions and temperature for flat plate solar collector. Air flow conditions.

**FIND:** (a) Heat loss with simultaneous velocity and thermal boundary layer development, (b) Heat loss with unheated starting length.

**SCHEMATIC:**

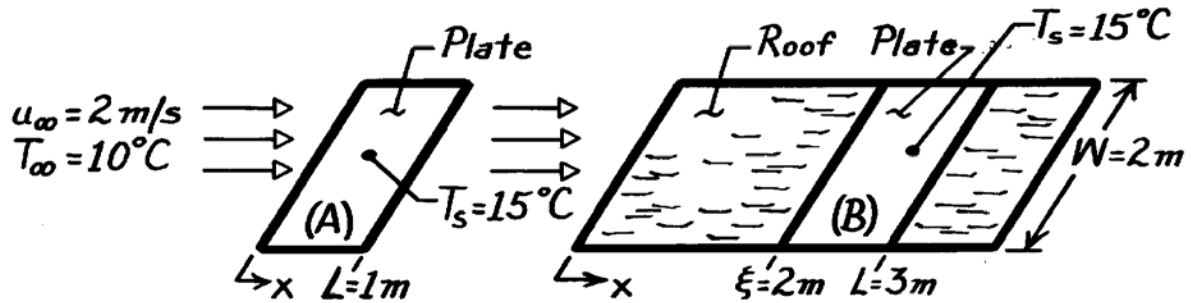

**ASSUMPTIONS:** (1) Steady-state conditions, (2) Negligible radiation, (3) Boundary layer is not disturbed by roof-plate interface, (4)  $Re_{x,c} = 5 \times 10^5$ .

**PROPERTIES:** Table A-4, Air ( $T_f = 285.5\text{K}$ , 1 atm):  $\nu = 14.6 \times 10^{-6} \text{ m}^2/\text{s}$ ,  $k = 0.0251 \text{ W/m}\cdot\text{K}$ ,  $Pr = 0.71$ .

**ANALYSIS:** (a) The Reynolds number for the plate of  $L = 1\text{ m}$  is

$$Re_L = \frac{u_\infty L}{\nu} = \frac{2 \text{ m/s} \times 1 \text{ m}}{14.6 \times 10^{-6} \text{ m}^2/\text{s}} = 1.37 \times 10^5 < Re_{x,c}$$

For laminar flow

$$\overline{Nu}_L = 0.664 Re_L^{1/2} Pr^{1/3} = 0.664 (1.37 \times 10^5)^{1/2} (0.71)^{1/3} = 219.2$$

$$q = \frac{k}{L} \overline{Nu}_L A_s (T_s - T_\infty) = \frac{0.0251 \text{ W/m}\cdot\text{K}}{1 \text{ m}} 219.2 (2 \text{ m}^2) 5^\circ\text{C} = 55 \text{ W.} \quad <$$

(b) The Reynolds number for the roof and collector of length  $L = 3\text{ m}$  is

$$Re_L = \frac{2 \text{ m/s} \times 3 \text{ m}}{14.6 \times 10^{-6} \text{ m}^2/\text{s}} = 4.11 \times 10^5 < Re_{x,c}$$

Hence, laminar boundary layer conditions exist throughout and the heat rate is

$$q = \int_{\xi}^L q'' dA = (T_s - T_\infty) 0.332 \left( \frac{u_\infty}{\nu} \right)^{1/2} Pr^{1/3} kW \int_{\xi}^L \frac{x^{-1/2} dx}{\left[ 1 - (\xi/x)^{3/4} \right]^{1/3}}$$

$$q = (5^\circ\text{C}) 0.332 \left( \frac{2 \text{ m/s}}{14.6 \times 10^{-6} \text{ m}^2/\text{s}} \right)^{1/2} (0.71)^{1/3} 0.0251 \frac{\text{W}}{\text{m}\cdot\text{K}} 2 \text{ m} \int_{\xi}^L \frac{x^{-1/2} dx}{\left[ 1 - (\xi/x)^{3/4} \right]^{1/3}}$$

Using a numerical technique to evaluate the integral,

$$q = 27.50 \int_2^3 \frac{x^{-1/2} dx}{\left[ 1 - (2.0/x)^{3/4} \right]^{1/3}} = 27.50 \times 1.417 = 39 \text{ W} \quad <$$

**COMMENTS:** Values of  $\bar{h}$  with and without the unheated starting length are 3.9 and 5.5  $\text{W/m}^2\cdot\text{K}$ . Prior development of the velocity boundary layer decreases  $\bar{h}$ .

### PROBLEM 7.44

**KNOWN:** Surface dimensions for an array of 10 silicon chips. Maximum allowable chip temperature. Air flow conditions.

**FIND:** Maximum allowable chip electrical power (a) without and (b) with a turbulence promoter at the leading edge.

**SCHEMATIC:**

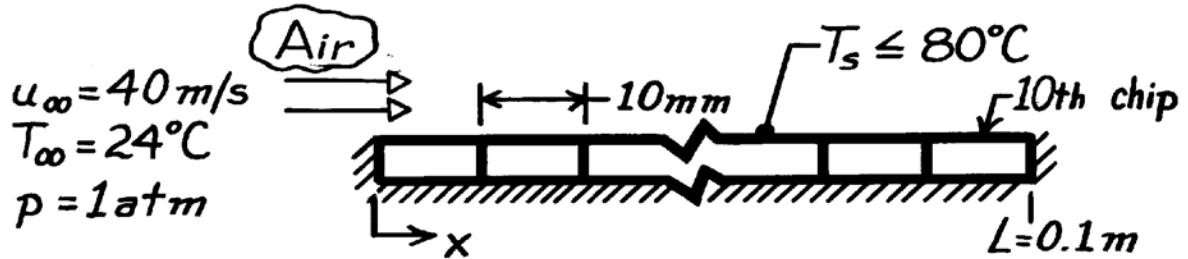

**ASSUMPTIONS:** (1) Steady-state conditions, (2) Film temperature of 52°C, (3) Negligible radiation, (4) Negligible heat loss through insulation, (5) Uniform heat flux at chip interface with air, (6)

$$Re_{x,c} = 5 \times 10^5.$$

**PROPERTIES:** Table A-4, Air ( $T_f = 325\text{K}$ , 1 atm):  $\nu = 18.4 \times 10^{-6} \text{ m}^2/\text{s}$ ,  $k = 0.0282 \text{ W/m}\cdot\text{K}$ ,  $Pr = 0.703$ .

**ANALYSIS:**  $Re_L = u_\infty L / \nu = 40 \text{ m/s} \times 0.1 \text{ m} / 18.4 \times 10^{-6} \text{ m}^2/\text{s} = 2.174 \times 10^5$ . Hence, flow is laminar over all chips without the promoter.

(a) For *laminar flow*, the minimum  $h_x$  exists on the last chip. Approximating the average coefficient for Chip 10 as the local coefficient at  $x = 95 \text{ mm}$ ,  $\bar{h}_{10} = h_x = 0.095 \text{ m}$ .

$$\bar{h}_{10} = 0.453 \frac{k}{x} Re_x^{1/2} Pr^{1/3}$$

$$Re_x = \frac{u_\infty x}{\nu} = \frac{40 \text{ m/s} \times 0.095 \text{ m}}{18.4 \times 10^{-6} \text{ m}^2/\text{s}} = 2.065 \times 10^5$$

$$\bar{h}_{10} = 0.453 \frac{0.0282 \text{ W/m}\cdot\text{K}}{0.095} \left(2.065 \times 10^5\right)^{1/2} (0.703)^{1/3} = 54.3 \text{ W/m}^2 \cdot \text{K}$$

$$q_{10} = \bar{h}_{10} A (T_s - T_\infty) = 54.3 \frac{\text{W}}{\text{m}^2 \cdot \text{K}} (0.01 \text{ m})^2 (80 - 24)^\circ \text{C} = 0.30 \text{ W}.$$

Hence, if all chips are to dissipate the same power and  $T_s$  is not to exceed 80°C.

$$q_{\max} = 0.30 \text{ W}. \quad <$$

(b) For *turbulent flow*,

$$\bar{h}_{10} = 0.0308 \frac{k}{x} Re_x^{4/5} Pr^{1/3} = 0.0308 \frac{0.0282 \text{ W/m}\cdot\text{K}}{0.095 \text{ m}} \left(2.065 \times 10^5\right)^{4/5} (0.703)^{1/3} = 145 \text{ W/m}^2 \cdot \text{K}$$

$$q_{10} = \bar{h}_{10} A (T_s - T_\infty) = 145 \frac{\text{W}}{\text{m}^2 \cdot \text{K}} (0.01 \text{ m})^2 (80 - 24)^\circ \text{C} = 0.81 \text{ W}.$$

Hence,  $q_{\max} = 0.81 \text{ W}.$  <

**COMMENTS:** It is far better to orient array normal to the air flow. Since  $\bar{h}_1 > \bar{h}_{10}$ , more heat could be dissipated per chip, and the same heat could be dissipated from each chip.

### PROBLEM 7.45

**KNOWN:** Dimensions and maximum allowable temperature of a silicon chip. Air flow conditions.

**FIND:** Maximum allowable power with or without unheated starting length.

**SCHEMATIC:**

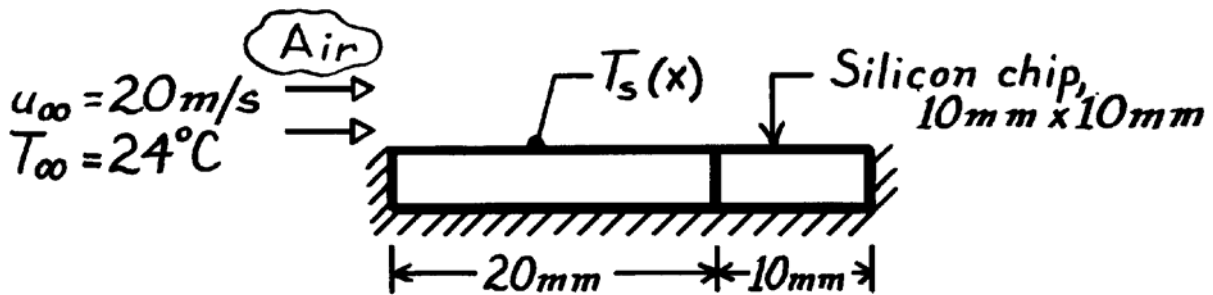

**ASSUMPTIONS:** (1) Steady-state conditions, (2)  $T_f = 52^\circ\text{C}$ , (3) Negligible radiation, (4) Negligible heat loss through insulation, (5) Uniform heat flux at chip-air interface, (6)  $\text{Re}_{x,c} = 5 \times 10^5$ .

**PROPERTIES:** Table A-4, Air ( $T_f = 325\text{K}$ , 1 atm):  $\nu = 18.41 \times 10^{-6} \text{ m}^2/\text{s}$ ,  $k = 0.0282 \text{ W/m}\cdot\text{K}$ ,  $\text{Pr} = 0.703$ .

**ANALYSIS:** For uniform heat flux, maximum  $T_s$  corresponds to minimum  $h_x$ . Without unheated starting length,

$$\text{Re}_L = \frac{u_\infty L}{\nu} = \frac{20 \text{ m/s} \times 0.01 \text{ m}}{18.41 \times 10^{-6} \text{ m}^2/\text{s}} = 10,864.$$

With the unheated starting length,  $L = 0.03 \text{ m}$ ,  $\text{Re}_L = 32,591$ . Hence, the flow is laminar in both cases and the minimum  $h_x$  occurs at the trailing edge ( $x = L$ ).

Without unheated starting length,

$$h_L = \frac{k}{L} 0.453 \text{Re}_L^{1/2} \text{Pr}^{1/3} = \frac{0.0282 \text{ W/m}\cdot\text{K}}{0.01 \text{ m}} 0.453 (10,864)^{1/2} (0.703)^{1/3}$$

$$h_L = 118 \text{ W/m}^2 \cdot \text{K}$$

$$q''(L) = h_L (T_s - T_\infty) = 118 \text{ W/m}^2 \cdot \text{K} (80 - 24)^\circ\text{C} = 6630 \text{ W/m}^2$$

$$q_{\max} = A_s q'' = (10^{-2} \text{ m})^2 6630 \text{ W/m}^2 = 0.66 \text{ W.} \quad <$$

With the unheated starting length,

$$h_L = \frac{k}{L} 0.453 \frac{\text{Re}_L^{1/2} \text{Pr}^{1/3}}{\left[1 - (\xi/L)^{3/4}\right]^{1/3}} = \frac{0.0282 \text{ W/m}\cdot\text{K}}{0.03 \text{ m}} 0.453 \frac{(32,591)^{1/2} (0.703)^{1/3}}{\left[1 - (0.02/0.03)^{3/4}\right]^{1/3}}$$

$$h_L = 107 \text{ W/m}^2 \cdot \text{K}$$

$$q''(L) = h_L (T_s - T_\infty) = 107 \text{ W/m}^2 \cdot \text{K} (80 - 24)^\circ\text{C} = 6013 \text{ W/m}^2$$

$$q_{\max} = A_s q'' = 10^{-4} \text{ m}^2 \times 6013 \text{ W/m}^2 = 0.60 \text{ W.} \quad <$$

**COMMENTS:** Prior velocity boundary layer development on the unheated starting section decreases  $h_x$ , although the effect diminishes with increasing  $x$ .

## PROBLEM 7.46

**KNOWN:** Cylinder diameter and surface temperature. Temperature and velocity of fluids in cross flow.

**FIND:** (a) Rate of heat transfer per unit length for the fluids: atmospheric air and saturated water, and engine oil, for velocity  $V = 5$  m/s, using the Churchill-Bernstein correlation, and (b) Compute and plot  $q'$  as a function of the fluid velocity  $0.5 \leq V \leq 10$  m/s.

**SCHEMATIC:**

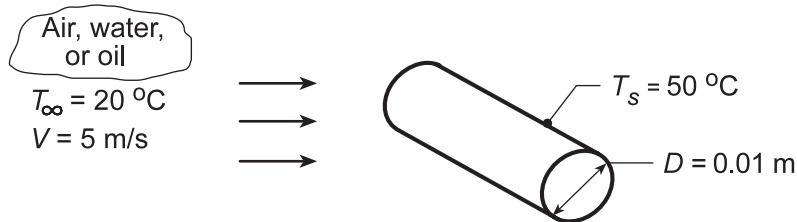

**ASSUMPTIONS:** (1) Steady-state conditions, (2) Uniform cylinder surface temperature.

**PROPERTIES:** Table A.4, Air ( $T_f = 308$  K, 1 atm):  $\nu = 16.69 \times 10^{-6}$  m<sup>2</sup>/s,  $k = 0.0269$  W/m·K,  $Pr = 0.706$ ; Table A.6, Saturated Water ( $T_f = 308$  K):  $\rho = 994$  kg/m<sup>3</sup>,  $\mu = 725 \times 10^{-6}$  N·s/m<sup>2</sup>,  $k = 0.625$  W/m·K,  $Pr = 4.85$ ; Table A.5, Engine Oil ( $T_f = 308$  K):  $\nu = 340 \times 10^{-6}$  m<sup>2</sup>/s,  $k = 0.145$  W/m·K,  $Pr = 4000$ .

**ANALYSIS:** (a) For each fluid, calculate the Reynolds number and use the Churchill-Bernstein correlation, Eq. 7.54,

$$\overline{Nu}_D = \frac{\bar{h}D}{k} = 0.3 + \frac{0.62 Re_D^{1/2} Pr^{1/3}}{\left[1 + (0.4/Pr)^{2/3}\right]^{1/4}} \left[1 + \left(\frac{Re_D}{282,000}\right)^{5/8}\right]^{4/5}$$

*Fluid: Atmospheric Air*

$$Re_D = \frac{VD}{\nu} = \frac{(5 \text{ m/s})0.01 \text{ m}}{16.69 \times 10^{-6} \text{ m}^2/\text{s}} = 2996$$

$$\overline{Nu}_D = 0.3 + \frac{0.62(2996)^{1/2} (0.706)^{1/3}}{\left[1 + (0.4/0.706)^{2/3}\right]^{1/4}} \left[1 + \left(\frac{2996}{282,000}\right)^{5/8}\right]^{4/5} = 28.1$$

$$\bar{h} = \frac{k}{D} \overline{Nu}_D = \frac{0.0269 \text{ W/m}\cdot\text{K}}{0.01 \text{ m}} 28.1 = 75.5 \text{ W/m}^2 \cdot \text{K}$$

$$q' = \bar{h}\pi D(T_s - T_\infty) = 75.5 \text{ W/m}^2 \cdot \text{K} \pi (0.01 \text{ m})(50 - 20)^\circ \text{C} = 71.1 \text{ W/m} \quad <$$

*Fluid: Saturated Water*

$$Re_D = \frac{VD}{\nu} = \frac{(5 \text{ m/s})0.01 \text{ m}}{725 \times 10^{-6} \text{ N}\cdot\text{s/m}^2 / 994 \text{ kg/m}^3} = 68,552$$

$$\overline{Nu}_D = 0.3 + \frac{0.62(68,552)^{1/2} (4.85)^{1/3}}{\left[1 + (0.4/4.85)^{2/3}\right]^{1/4}} \left[1 + \left(\frac{68,552}{282,000}\right)^{5/8}\right]^{4/5} = 347$$

Continued...

**PROBLEM 7.46 (Cont.)**

$$\bar{h} = \frac{k}{D} \overline{\text{Nu}}_D = \frac{0.625 \text{ W/m} \cdot \text{K}}{0.01 \text{ m}} 347 = 21,690 \text{ W/m}^2 \cdot \text{K} \quad q' = 20,438 \text{ W/m} \quad <$$

Fluid: Engine Oil

$$\text{Re}_D = \frac{VD}{\nu} = \frac{(5 \text{ m/s})0.01 \text{ m}}{340 \times 10^{-6} \text{ m}^2/\text{s}} = 147$$

$$\overline{\text{Nu}}_D = 0.3 + \frac{0.62(147)^{1/2} (4000)^{1/3}}{\left[1 + (0.4/4000)^{2/3}\right]^{1/4}} \left[1 + \left(\frac{147}{282,000}\right)^{5/8}\right]^{4/5} = 120$$

$$\bar{h} = \frac{k}{D} \overline{\text{Nu}}_D = \frac{0.145 \text{ W/m} \cdot \text{K}}{0.01 \text{ m}} 120 = 1740 \text{ W/m}^2 \cdot \text{K} \quad q' = 1639 \text{ W/m} \quad <$$

(b) Using the *IHT Correlations Tool, External Flow, Cylinder*, along with the *Properties Tool* for each of the fluids, the heat rates,  $q'$ , were calculated for the range  $0.5 \leq V \leq 10 \text{ m/s}$ . Note the  $q'$  scale multipliers for the air and oil fluids which permit easy comparison of the three curves.

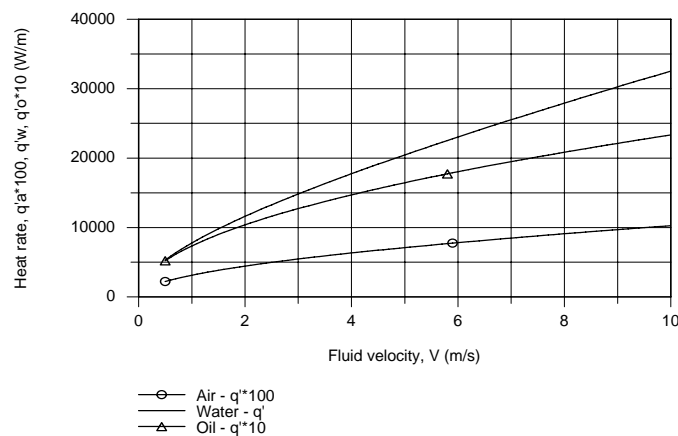

**COMMENTS:** (1) Note the inapplicability of the Zukauskas relation, Eq. 7.53, since  $\text{Pr}_{\text{oil}} > 500$ .

(2) In the plot above, recognize that the heat rate for the water is more than 10 times that with oil and 300 times that with air. How do changes in the velocity affect the heat rates for each of the fluids?

### PROBLEM 7.47

**KNOWN:** Conditions associated with air in cross flow over a pipe.

**FIND:** (a) Drag force per unit length of pipe, (b) Heat transfer per unit length of pipe.

**SCHEMATIC:**

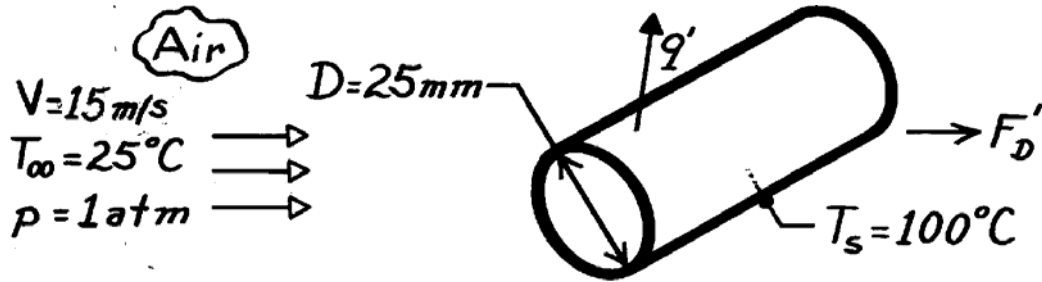

**ASSUMPTIONS:** (1) Steady-state conditions, (2) Uniform cylinder surface temperature, (3) Negligible radiation effects.

**PROPERTIES:** Table A-4, Air ( $T_f = 335 \text{ K}$ , 1 atm):  $\nu = 19.31 \times 10^{-6} \text{ m}^2/\text{s}$ ,  $\rho = 1.048 \text{ kg/m}^3$ ,  $k = 0.0288 \text{ W/m}\cdot\text{K}$ ,  $\text{Pr} = 0.702$ .

**ANALYSIS:** (a) From the definition of the drag coefficient with  $A_f = DL$ , find

$$F_D = C_D A_f \frac{\rho V^2}{2}$$

$$F_D' = C_D D \frac{\rho V^2}{2}$$

With

$$\text{Re}_D = \frac{VD}{\nu} = \frac{15 \text{ m/s} \times (0.025 \text{ m})}{19.31 \times 10^{-6} \text{ m}^2/\text{s}} = 1.942 \times 10^4$$

from Fig. 7.9,  $C_D \approx 1.1$ . Hence

$$F_D = 1.1(0.025 \text{ m}) 1.048 \text{ kg/m}^3 (15 \text{ m/s})^2 / 2 = 3.24 \text{ N/m.} \quad <$$

(b) Using Hilpert's relation, with  $C = 0.193$  and  $m = 0.618$  from Table 7.2,

$$\bar{h} = \frac{k}{D} C \text{Re}_D^m \text{Pr}^{1/3} = \frac{0.0288 \text{ W/m}\cdot\text{K}}{0.025 \text{ m}} \times 0.193 (1.942 \times 10^4)^{0.618} (0.702)^{1/3}$$

$$\bar{h} = 88 \text{ W/m}^2 \cdot \text{K}.$$

Hence, the heat rate per unit length is

$$q' = \bar{h}(\pi D) (T_s - T_\infty) = 88 \text{ W/m}^2 \cdot \text{K} (\pi \times 0.025 \text{ m}) (100 - 25)^\circ\text{C} = 520 \text{ W/m.} \quad <$$

**COMMENTS:** Using the Zukauskas correlation and evaluating properties at  $T_\infty$  ( $\nu = 15.71 \times 10^{-6} \text{ m}^2/\text{s}$ ,  $k = 0.0261 \text{ W/m}\cdot\text{K}$ ,  $\text{Pr} = 0.707$ ), but with  $\text{Pr}_s = 0.695$  at  $T_s$ ,

$$\bar{h} = \frac{0.0261}{0.025} 0.26 \left( \frac{15 \times 0.025}{15.71 \times 10^{-6}} \right)^{0.6} (0.707)^{0.37} (0.707/0.695)^{1/4} = 102 \text{ W/m}^2 \cdot \text{K}.$$

This result agrees with that obtained from Hilpert's relation to within the uncertainty normally associated with convection correlations.

## PROBLEM 7.48

**KNOWN:** Dimensions of a vertical copper tube experiencing crossflow. Air velocity and temperature, water temperature inside the tube.

**FIND:** (a) The heat loss per unit mass from the water (W/kg) when the pipe is full. (b) The heat loss from the water (W/kg) when the pipe is half full.

**SCHEMATIC:**

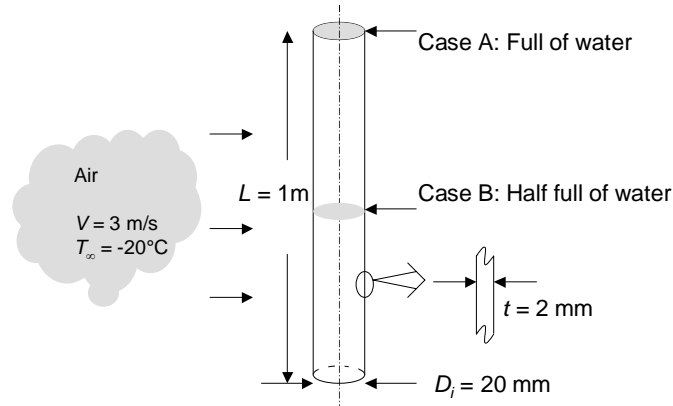

**ASSUMPTIONS:** (1) Steady-state conditions, (2) Constant properties, (3) Tube behaves as an infinite fin, (4) Water is well-mixed, (5) One-dimensional heat transfer, (6) Inside copper wall temperature at water temperature, (7) Negligible heat transfer to/from the gas above the liquid water, (8) Negligible radiation.

**PROPERTIES:** Table A.4, air assumed: ( $T_f = (0^\circ\text{C} - 20^\circ\text{C})/2 = -10^\circ\text{C} \approx 263\text{K}$ ,  $p = 1\text{ atm}$ ):  $\nu = 12.6 \times 10^{-6}\text{ m}^2/\text{s}$ ,  $Pr = 0.717$ ,  $k = 0.0233\text{ W/m}\cdot\text{K}$ . Table A.1, copper: ( $T = 300\text{ K}$ ):  $k_{\text{CU}} = 401\text{ W/m}\cdot\text{K}$ . Table A.6, water ( $T = 273\text{ K}$ ),  $\rho = 1000\text{ kg/m}^3$ .

**ANALYSIS:** For either case, the average convection coefficient about the tube must be evaluated. The Reynolds number, based upon the outer diameter  $D_o = 20\text{ mm} + 4\text{ mm} = 24\text{ mm}$  is  $Re_D = VD_o/\nu = 3\text{ m/s} \times 24 \times 10^{-3}\text{ m}/12.6 \times 10^{-6}\text{ m}^2/\text{s} = 5714$ . Using Eq. 7.54, the average heat transfer coefficient about the exterior of the tube is

$$h = \frac{0.0233\text{ W/m}\cdot\text{K}}{24 \times 10^{-3}\text{ m}} \left\{ 0.3 + \frac{0.62(5714^{1/2})0.717^{1/3}}{\left[1 + (0.4/0.717)^{2/3}\right]^{1/4}} \left[ 1 + \left(\frac{5714}{282,000}\right)^{5/8} \right]^{4/5} \right\} = 38.56\text{ W/m}^2\cdot\text{K}$$

(a) From Eq. 3.34 heat loss from the water is

$$q = 1\text{ m} \times \frac{(0 - (-20)^\circ\text{C})}{\frac{\ln(24/20)}{2\pi \times 401\text{ W/m}\cdot\text{K}} + \frac{1}{\pi \times 24 \times 10^{-3}\text{ m} \times 38.56\text{ W/m}^2\cdot\text{K}}} = 58\text{ W}$$

while the mass of water is  $M = \pi(D_i^2/4)L\rho = \pi \times (20 \times 10^{-3}\text{ m})^2/4 \times 1\text{ m} \times 1000\text{ kg/m}^3 = 0.314\text{ kg}$ . Hence, the heat loss per unit mass of water is

$$q_M = q/M = 58\text{ W}/0.314\text{ kg} = 185\text{ W/kg.} \quad \leftarrow$$

Continued...



### PROBLEM 7.48 (Cont.)

(b) When the tube is half full, the upper half of the tube will act as a fin. The total heat loss per unit mass will be  $q_M = q_{M1} + q_{M2}$  where  $q_{M1}$  is the radial heat loss that is the same as in part (a) and  $q_{M2}$  is the heat loss to the upper half of the copper tubing, which serves as a fin. From part (a)  $q_{M1} = 185$  W/kg. Assuming an infinite fin and recognizing that the cross-sectional area is associated with the inner and outer diameters of the tubing,

$$\begin{aligned} q_{M2} &= \sqrt{hPkA_c} \theta_b / M \\ &= \sqrt{38.56 \text{ W/m}^2 \cdot \text{K} \times \pi \times 24 \times 10^{-3} \text{ m} \times 401 \text{ W/m} \cdot \text{K} \times \pi \left( (24 \times 10^{-3} \text{ m})^2 - (20 \times 10^{-3} \text{ m})^2 \right) / 4} \\ &\quad \times (0 - (-20))^\circ\text{C} / 0.157 \text{ kg} \\ &= 51.3 \text{ W/kg} \end{aligned}$$

Therefore,  $q_M = 185 \text{ W/kg} + 51.3 \text{ W/kg} = 236 \text{ W/kg}$  <

**COMMENTS:** (1) The fin effect is significant, and the water in the half-full tube will freeze before the water in the full tube. (2) The temperature distribution in the copper tubing above the water level in the half-full tubing is  $\theta/\theta_b = \exp^{-mx}$  where  $x$  is a local coordinate with origin at the water level. For this problem,

$$\begin{aligned} m &= \sqrt{hP/kA_c} = \sqrt{4hD_o/k(D_o^2 - D_i^2)} \\ &= \sqrt{4 \times 38.56 \text{ W/m}^2 \cdot \text{K} \times 24 \times 10^{-3} \text{ m} / 401 \text{ W/m} \cdot \text{K} \left( (24 \times 10^{-3} \text{ m})^2 - (20 \times 10^{-3} \text{ m})^2 \right)} = 7.24 \text{ m}^{-1}. \end{aligned}$$

Therefore, over a 0.5 m length above the water surface for part (b), the temperature decreases to  $T(x = 0.5 \text{ m}) = -20^\circ\text{C} + (20^\circ\text{C})\exp(-7.24 \text{ m}^{-1} \times 0.5 \text{ m}) = -19.5^\circ\text{C}$ . The assumption of an infinitely long fin is reasonable.

### PROBLEM 7.49

**KNOWN:** Initial temperature, power dissipation, diameter, and properties of heating element. Velocity and temperature of air in cross flow.

**FIND:** (a) Steady-state temperature, (b) Time to come within 10°C of steady-state temperature.

**SCHEMATIC:**

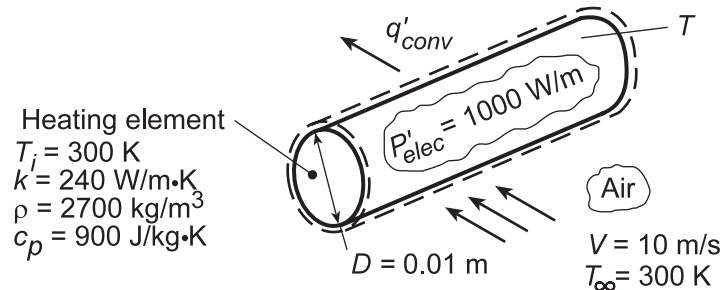

**ASSUMPTIONS:** (1) Uniform heater temperature, (2) Negligible radiation.

**PROPERTIES:** Table A.4, air (assume  $T_f \approx 450$  K):  $\nu = 32.39 \times 10^{-6} \text{ m}^2/\text{s}$ ,  $k = 0.0373 \text{ W/m}\cdot\text{K}$ ,  $\text{Pr} = 0.686$ .

**ANALYSIS:** (a) Performing an energy balance for steady-state conditions, we obtain

$$q'_{\text{conv}} = \bar{h}(\pi D)(T - T_{\infty}) = P'_{\text{elec}} = 1000 \text{ W/m}$$

With

$$\text{Re}_D = \frac{VD}{\nu} = \frac{(10 \text{ m/s})0.01 \text{ m}}{32.39 \times 10^{-6} \text{ m}^2/\text{s}} = 3,087$$

the Churchill and Bernstein correlation, Eq. 7.54, yields

$$\bar{\text{Nu}}_D = 0.3 + \frac{0.62 \text{Re}_D^{1/2} \text{Pr}^{1/3}}{\left[1 + (0.4/\text{Pr})^{2/3}\right]^{1/4}} \left[1 + \left(\frac{\text{Re}_D}{282,000}\right)^{5/8}\right]^{4/5}$$

$$\bar{\text{Nu}}_D = 0.3 + \frac{0.62(3087)^{1/2} (0.686)^{1/3}}{\left[1 + (0.4/0.686)^{2/3}\right]^{1/4}} \left[1 + \left(\frac{3087}{282,000}\right)^{5/8}\right]^{4/5} = 28.2$$

$$\bar{h} = \frac{k}{D} \bar{\text{Nu}}_D = \frac{0.0373 \text{ W/m}\cdot\text{K}}{0.010 \text{ m}} 28.2 = 105.2 \text{ W/m}^2 \cdot \text{K}$$

Hence, the steady-state temperature is

$$T = T_{\infty} + \frac{P'_{\text{elec}}}{\pi D \bar{h}} = 300 \text{ K} + \frac{1000 \text{ W/m}}{\pi(0.01 \text{ m})105.2 \text{ W/m}^2 \cdot \text{K}} = 603 \text{ K} \quad <$$

(b) With  $\text{Bi} = \bar{h}r_0/k = 105.2 \text{ W/m}^2 \cdot \text{K}(0.005 \text{ m})/240 \text{ W/m}\cdot\text{K} = 0.0022$ , a lumped capacitance analysis may be performed. The time response of the heater is given by Eq. 5.25, which, for  $T_i = T_{\infty}$ , reduces to

$$T = T_{\infty} + (b/a)[1 - \exp(-at)]$$

Continued...

### PROBLEM 7.49 (Cont.)

where  $a = 4\bar{h}/D\rho c_p = (4 \times 105.2 \text{ W/m}^2 \cdot \text{K}) / (0.01 \text{ m} \times 2700 \text{ kg/m}^3 \times 900 \text{ J/kg} \cdot \text{K}) = 0.0173 \text{ s}^{-1}$  and  $b/a = P'_{\text{elec}}/\pi D\bar{h} = 1000 \text{ W/m} / \pi (0.01 \text{ m} \times 105.2 \text{ W/m}^2 \cdot \text{K}) = 302.6 \text{ K}$ . Hence,

$$[1 - \exp(-0.0173t)] = \frac{(593 - 300)\text{K}}{302.6\text{K}} = 0.968$$

$$t \approx 200\text{s}$$

&lt;

**COMMENTS:** (1) For  $T = 603 \text{ K}$  and a representative emissivity of  $\varepsilon = 0.8$ , net radiation exchange between the heater and surroundings at  $T_{\text{sur}} = T_{\infty} = 300 \text{ K}$  would be  $q'_{\text{rad}} = \varepsilon\sigma(\pi D)(T^4 - T_{\text{sur}}^4) = 0.8 \times 5.67 \times 10^{-8} \text{ W/m}^2 \cdot \text{K}^4 (\pi \times 0.01 \text{ m})(603^4 - 300^4)\text{K}^4 = 177 \text{ W/m}$ . Hence, although small, radiation exchange is not negligible. The effects of radiation are considered in Problem 7.50.

(2) The assumed value of  $T_f$  is very close to the actual value, rendering the selected air properties accurate.

## PROBLEM 7.50

**KNOWN:** Initial temperature, power dissipation, diameter, and properties of a heating element. Velocity and temperature of air in cross flow. Temperature of surroundings.

**FIND:** (a) Steady-state temperature, (b) Time to come within 10°C of steady-state temperature, (c) Variation of power dissipation required to maintain a fixed heater temperature of 275°C over a range of velocities.

**SCHEMATIC:**

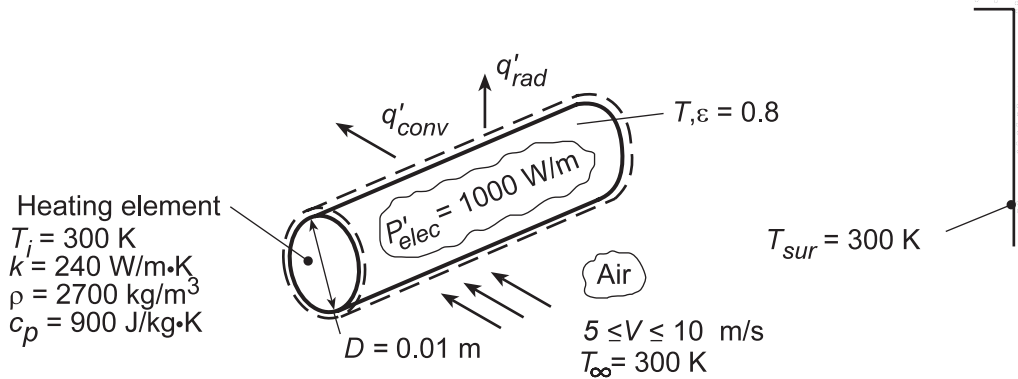

**ASSUMPTIONS:** Uniform heater surface temperature.

**ANALYSIS:** (a) Performing an energy balance for steady-state conditions, we obtain

$$q'_{conv} + q'_{rad} = P'_{elec}$$

$$\bar{h}(\pi D)(T - T_{\infty}) + \varepsilon\sigma(\pi D)(T^4 - T_{sur}^4) = P'_{elec}$$

$$(\pi \times 0.01 \text{ m}) \left[ \bar{h}(T - 300) \text{ K} + 0.8(5.67 \times 10^{-8} \text{ W/m}^2 \cdot \text{K}^4)(T^4 - 300^4) \text{ K}^4 \right] = 1000 \text{ W/m}$$

Using the *IHT Energy Balance Model* for an *Isothermal Solid Cylinder* with the *Correlations Tool Pad* for a *Cylinder in Crossflow* and the *Properties Tool Pad* for *Air*, we obtain

$$T = 562.4 \text{ K} \quad \leftarrow$$

where  $\bar{h} = 105.4 \text{ W/m}^2 \cdot \text{K}$ ,  $h_r = 15.9 \text{ W/m}^2 \cdot \text{K}$ ,  $q'_{conv} = 868.8 \text{ W/m}$ , and  $q'_{rad} = 131.2 \text{ W/m}$ .

(b) With  $Bi = (\bar{h} + h_r)r_0/k = (121.3 \text{ W/m}^2 \cdot \text{K})0.005 \text{ m}/240 \text{ W/m} \cdot \text{K} = 0.0025$ , the transient behavior may be analyzed using the lumped capacitance method. Using the *IHT Lumped Capacitance Model* to perform the numerical integration, the following temperature histories were obtained.

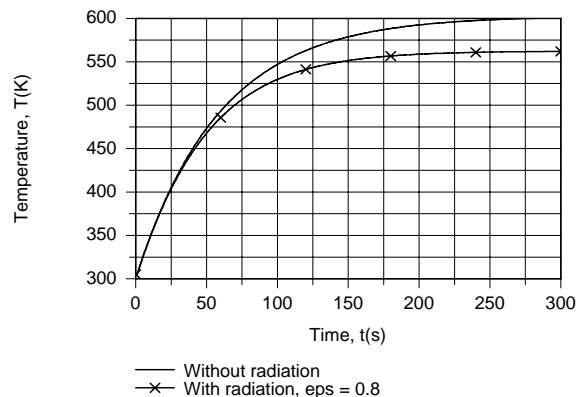

Continued...

### PROBLEM 7.50 (Cont.)

The agreement between predictions with and without radiation for  $t < 50$ s implies negligible radiation. However, as the heater temperature increases with time, radiation becomes significant, yielding a reduced heater temperature. Steady-state temperatures correspond to 562.4 K and 602.8 K, with and without radiation, respectively. The time required for the heater to reach 552.4 K (with radiation) is  $t \approx 155$ s.

(c) If the heater temperature is to be maintained at a fixed value in the face of velocity excursions, provision must be made for adjusting the heater power. Using the *Explore* and *Graph* options of IHT with the model of part (a), the following results were obtained.

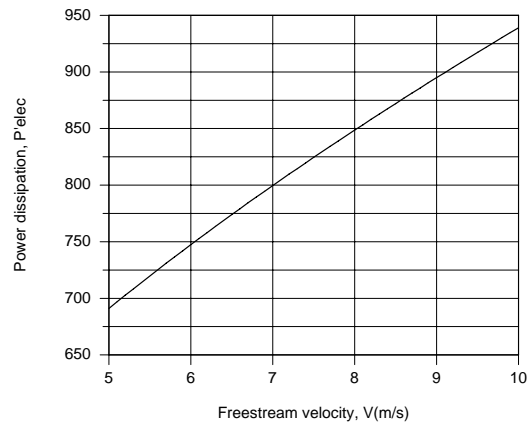

For  $T = 275^\circ\text{C} = 548$  K, the controller would compensate for velocity reductions from 10 to 5 m/s by reducing the power from approximately 935 to 690 W/m.

**COMMENTS:** Although convection heat transfer substantially exceeds radiation heat transfer, radiation is not negligible and should be included in the analysis. If it is neglected,  $T = 603$  K would be predicted for  $P'_{\text{elec}} = 1000$  W/m, in contrast to 562 K from the results of part (a).

## PROBLEM 7.51

**KNOWN:** Geometry and dimensions of three pin fins. Velocity and temperature of air in cross flow.

**FIND:** Which fin has the largest heat transfer rate.

**SCHEMATIC:**

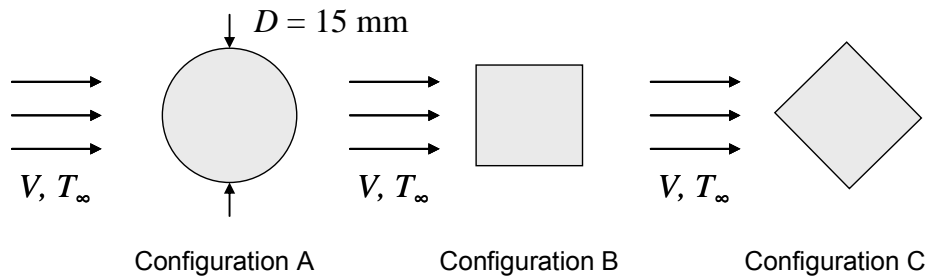

$V = 10 \text{ m/s}$  for all cases

**ASSUMPTIONS:** (1) Steady-state, (2) Constant properties, (3) Fins can be treated as infinitely long, (4) Presence of fin base doesn't affect heat transfer coefficients.

**PROPERTIES:** Table A-4 Air ( $T = 350 \text{ K}$ ):  $\nu_a = 20.92 \times 10^{-6} \text{ m}^2/\text{s}$

**ANALYSIS:** For infinitely long fins, the fin heat transfer rate is given by Equation 3.85:

$$q_f = \sqrt{hPkA_c} \theta_b$$

In every case, the heat transfer coefficient is found from a correlation of the form,  $\overline{Nu}_D = CRe_D^m Pr^{1/3}$ , thus

$$q_f = \sqrt{\frac{k_a}{D} CRe_D^m Pr_a^{1/3} PkA_c} \theta_b$$

where subscript  $a$  refers to air properties. Since each fin has the same cross-sectional area, the parameters that vary from one configuration to another are  $D$ ,  $C$ ,  $Re_D$ ,  $m$ , and  $P$ . Thus, it is sufficient to examine the combination parameter  $CRe_D^m P / D$  to determine which fin has the largest heat transfer rate.

The cross-sectional area of the circular cylinder is  $A_c = \pi D^2/4$ . Thus the dimension of the square,  $D_s$ , is  $D_s = A_c^{1/2} = \pi^{1/2} D / 2 = \pi^{1/2} (15 \text{ mm}) / 2 = 13.3 \text{ mm}$ . The dimension of the diamond is the same, however  $D_d$  is defined differently. Referring to Table 7.3,  $D_d = 2^{1/2} D_s = 2^{1/2} (13.3 \text{ mm}) = 18.8 \text{ mm}$ . The perimeters are  $P_c = \pi D = 47.1 \text{ mm}$  for the circular cylinder and  $P_s = P_d = 4D_s = 53.2 \text{ mm}$  for both the square and diamond configurations.

The Reynolds number can be calculated from  $Re = VD/\nu_a$ , then  $C$  and  $m$  can be found from Tables 7.2 and 7.3 for the different configurations. The results are tabulated below for all three configurations. A line has been included to represent the heat transfer coefficient, which is proportional to  $CRe_D^m / D$ .

Continued...

### PROBLEM 7.51 (Cont.)

	Configuration A (circular)	Configuration B (square)	Configuration C (diamond)
$D$ (mm)	15	13.3	18.8
$P$ (mm)	47.1	53.2	53.2
$Re_D = VD/\nu_a$	7,170	6,358	8,987
$C$	0.193	0.158	0.304
$m$	0.618	0.66	0.59
$Cre_D^m / D$ ( $m^{-1}$ ) $\sim h$	3106	3846	3478
$Cre_D^m P / D \sim q_f$	146	205	185

For fins of equal mass, the square fin configuration has the largest heat transfer rate.

<

**COMMENTS:** (1) For the same cross-sectional area, the square and diamond configurations have larger perimeters than the circular cylinder, which contributes to the larger heat transfer rate. (2) For the same cross-sectional area, the square and diamond configurations have larger heat transfer coefficients, which also contributes to the larger heat transfer rates.

## PROBLEM 7.52

**KNOWN:** Pin fin of 10 mm diameter dissipates 30 W by forced convection in cross-flow of air with  $Re_D = 4000$ .

**FIND:** Fin heat rate if diameter is doubled while all conditions remain the same.

**SCHEMATIC:**

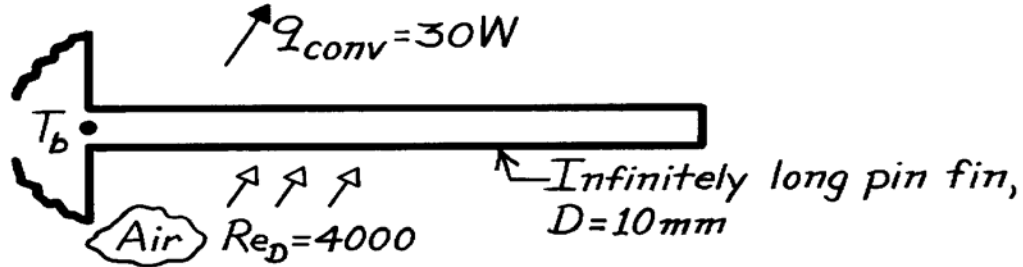

**ASSUMPTIONS:** (1) Pin behaves as infinitely long fin, (2) Conditions of flow, as well as base and air temperatures, remain the same for both situations, (3) Negligible radiation heat transfer.

**ANALYSIS:** For an infinitely long pin fin, the fin heat rate is

$$q_f = q_{conv} = (\bar{h} P k A_c)^{1/2} \theta_b$$

where  $P = \pi D$  and  $A_c = \pi D^2/4$ . Hence,

$$q_{conv} \sim (\bar{h} \cdot D \cdot D^2)^{1/2}.$$

For forced convection cross-flow over a cylinder, an appropriate correlation for estimating the dependence of  $\bar{h}$  on the diameter is

$$\overline{Nu}_D = \frac{\bar{h} D}{k} = C Re_D^m Pr^{1/3} = C \left( \frac{VD}{\nu} \right)^m Pr^{1/3}.$$

From Table 7.2 for  $Re_D = 4000$ , find  $m = 0.466$  and

$$\bar{h} \sim D^{-1} (D)^{0.466} = D^{-0.534}.$$

It follows that

$$q_{conv} \sim (D^{-0.534} \cdot D \cdot D^2)^{1/2} = D^{1.23}.$$

Hence, with  $q_1 \rightarrow D_1$  (10 mm) and  $q_2 \rightarrow D_2$  (20 mm), find

$$q_2 = q_1 \left( \frac{D_2}{D_1} \right)^{1.23} = 30 \text{ W} \left( \frac{20}{10} \right)^{1.23} = 70.4 \text{ W.} \quad <$$

**COMMENTS:** The effect of doubling the diameter, with all other conditions remaining the same, is to increase the fin heat rate by a factor of 2.35. The effect is nearly linear, with enhancements due to the increase in surface and cross-sectional areas ( $D^{1.5}$ ) exceeding the attenuation due to a decrease in the heat transfer coefficient ( $D^{-0.267}$ ). Note that, with increasing Reynolds number, the exponent  $m$  increases and there is greater heat transfer enhancement due to increasing the diameter.



## PROBLEM 7.53

**KNOWN:** Pin fin installed on a surface with prescribed heat rate and temperature.

**FIND:** (a) Maximum heat removal rate possible, (b) Length of the fin, (c) Effectiveness,  $\varepsilon_f$ , (d) Percentage increase in heat rate from surface due to fin.

**SCHEMATIC:**

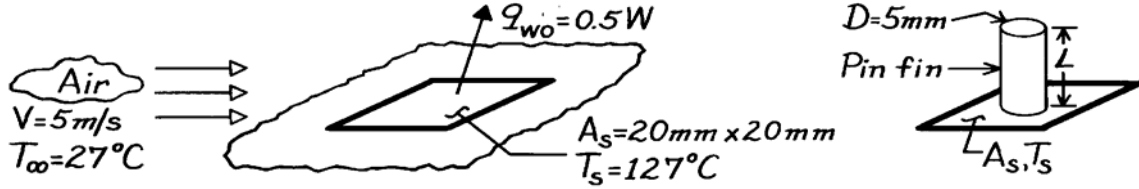

**ASSUMPTIONS:** (1) Steady-state conditions, (2) Conditions over  $A_s$  are uniform for both situations, (3) Conditions over fin length are uniform, (4) Flow over pin fin approximates cross-flow.

**PROPERTIES:** Table A-4, Air ( $T_f = (T_\infty + T_s)/2 = (27 + 127)^\circ\text{C}/2 = 350\text{ K}$ ):  $\nu = 20.92 \times 10^{-6}\text{ m}^2/\text{s}$ ,  $k = 30.0 \times 10^{-3}\text{ W/m}\cdot\text{K}$ ,  $\text{Pr} = 0.700$ . Table A-1, SS AISI304 ( $\bar{T} = T_f = 350\text{ K}$ ):  $k = 15.8\text{ W/m}\cdot\text{K}$ .

**ANALYSIS:** (a) Maximum heat rate from fin occurs when fin is infinitely long,

$$q_f = M = (\bar{h}PkA_c)^{1/2} \theta_b \quad (1)$$

from Eq. 3.85. Estimate convection heat transfer coefficient for cross-flow over cylinder,

$$\text{Re}_D = \frac{VD}{\nu} = 5\text{ m/s} \times 0.005\text{ m} / 20.92 \times 10^{-6}\text{ m}^2/\text{s} = 1195.$$

Using the Hilpert correlation, Eq. 7.52, with Table 7.2, find

$$\bar{h} = \frac{k}{D} \text{CRe}_D^m \text{Pr} = (0.030\text{ W/m}\cdot\text{K} / 0.005\text{ m}) 0.683 (1195)^{0.466} (0.700)^{1/3} = 98.9\text{ W/m}^2\cdot\text{K}$$

From Eq. (1), with  $P = \pi D$ ,  $A_c = \pi D^2/4$ , and  $\theta_b = T_s - T_\infty$ , find

$$q_f = \left( 98.9\text{ W/m}^2\cdot\text{K} \times \pi (0.005\text{ m}) \times 15.8\text{ W/m}\cdot\text{K} \times \pi (0.005\text{ m})^2 / 4 \right)^{1/2} (127 - 27)\text{ K} = 2.20\text{ W}. <$$

(b) From Example 3.9,  $L \approx L_\infty = 2.65(kA_c/hP)^{1/2}$ . Hence,

$$L \approx L_\infty = 2.65 \left[ 15.8\text{ W/m}\cdot\text{K} \times \pi (0.005\text{ m})^2 / 4 / 98.9\text{ W/m}^2\cdot\text{K} \times \pi (0.005\text{ m}) \right]^{1/2} = 37.4\text{ mm}. <$$

(c) From Eq. 3.86, with  $h_s$  used for the base area  $A_s$ , the effectiveness is

$$\varepsilon_f = \frac{q_f}{h_s A_{c,b} \theta_b} = \frac{q_f}{q_{w0}} \frac{A_s}{A_{c,b}} = \frac{2.2\text{ W}}{0.5\text{ W}} \cdot \frac{(0.020 \times 0.020)\text{ m}^2}{\pi (0.005\text{ m})^2 / 4} = 89.6 <$$

where  $h_s = q_{w0} / A_s \theta_b$ .

(d) The percentage increase in heat rate with the installed fin (w) is

$$\frac{q_w - q_{w0}}{q_{w0}} \times 100 = \left( \left[ q_f + h_s \left( A_s - \pi D^2 / 4 \right) (T_s - T_\infty) \right] - q_{w0} \right) \times 100 / q_{w0}$$

$$\Delta q/q = \left\{ \left[ 2.2\text{ W} + 12.5\text{ W/m}^2\cdot\text{K} \left( [0.02\text{ m}]^2 - (\pi/4)(0.005\text{ m})^2 \right) 100\text{ K} - 0.5\text{ W} \right] \times 100 / 0.5\text{ W} \right\}$$

$$\Delta q/q = 435\%. <$$

## PROBLEM 7.54

**KNOWN:** Dimensions of chip and pin fin. Chip temperature. Free stream velocity and temperature of air coolant.

**FIND:** (a) Average pin convection coefficient, (b) Pin heat transfer rate, (c) Total heat rate, (d) Effect of velocity and pin diameter on total heat rate.

**SCHEMATIC:**

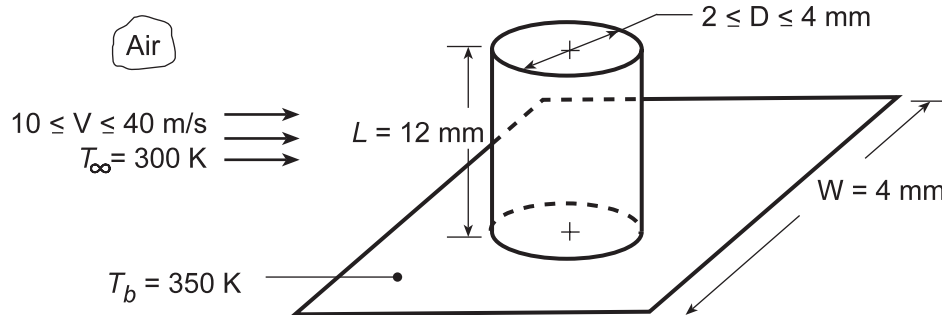

**ASSUMPTIONS:** (1) Steady-state conditions, (2) One-dimensional conduction in pin, (3) Constant properties, (4) Convection coefficients on pin surface (tip and side) and chip surface correspond to single cylinder in cross flow, (5) Negligible radiation.

**PROPERTIES:** Table A.1, Copper (350 K):  $k = 399 \text{ W/m}\cdot\text{K}$ ; Table A.4, Air ( $T_f \approx 325 \text{ K}$ , 1 atm):  $\nu = 18.41 \times 10^{-6} \text{ m}^2/\text{s}$ ,  $k = 0.0282 \text{ W/m}\cdot\text{K}$ ,  $\text{Pr} = 0.704$ .

**ANALYSIS:** (a) With  $V = 10 \text{ m/s}$  and  $D = 0.002 \text{ m}$ ,

$$\text{Re}_D = \frac{VD}{\nu} = \frac{10 \text{ m/s} \times 0.002 \text{ m}}{18.41 \times 10^{-6} \text{ m}^2/\text{s}} = 1087$$

Using the Churchill and Bernstein correlations, Eq. (7.54),

$$\overline{\text{Nu}}_D = 0.3 + \frac{0.62 \text{Re}_D^{1/2} \text{Pr}^{1/3}}{\left[1 + (0.4/\text{Pr})^{2/3}\right]^{1/4}} \left[1 + \left(\frac{\text{Re}_D}{282,000}\right)^{5/8}\right]^{4/5} = 16.7$$

$$\bar{h} = (\overline{\text{Nu}}_D k / D) = (16.7 \times 0.0282 \text{ W/m}\cdot\text{K} / 0.002 \text{ m}) = 235 \text{ W/m}^2 \cdot \text{K} \quad <$$

(b) For the fin with tip convection and

$$M = \left(\bar{h} \pi D k \pi D^2 / 4\right)^{1/2} \theta_b = (\pi/2) \left[235 \text{ W/m}^2 \cdot \text{K} (0.002 \text{ m})^3 399 \text{ W/m}\cdot\text{K}\right]^{1/2} 50 \text{ K} = 2.15 \text{ W}$$

$$m = (\bar{h} P / k A_c)^{1/2} = \left(4 \times 235 \text{ W/m}^2 \cdot \text{K} / 399 \text{ W/m}\cdot\text{K} \times 0.002 \text{ m}\right)^{1/2} = 34.3 \text{ m}^{-1}$$

$$mL = 34.3 \text{ m}^{-1} (0.012 \text{ m}) = 0.412$$

$$(\bar{h} / mk) = \left(235 \text{ W/m}^2 \cdot \text{K} / 34.3 \text{ m}^{-1} \times 399 \text{ W/m}\cdot\text{K}\right) = 0.0172.$$

The fin heat rate is

$$q_f = M \frac{\sinh mL + (\bar{h} / mk) \cosh mL}{\cosh mL + (\bar{h} / mk) \sinh mL} = 0.868 \text{ W} \quad <$$

Continued...

### PROBLEM 7.54 (Cont.)

(c) The total heat rate is that from the base and through the fin,

$$q = q_b + q_f = \bar{h} \left( W^2 - \pi D^2 / 4 \right) \theta_b + q_f = (0.151 + 0.868) W = 1.019 W .$$

<

(d) Using the IHT Extended Surface Model for a Pin Fin with the Correlations Tool Pad for a Cylinder in crossflow and Properties Tool Pad for Air, the following results were generated.

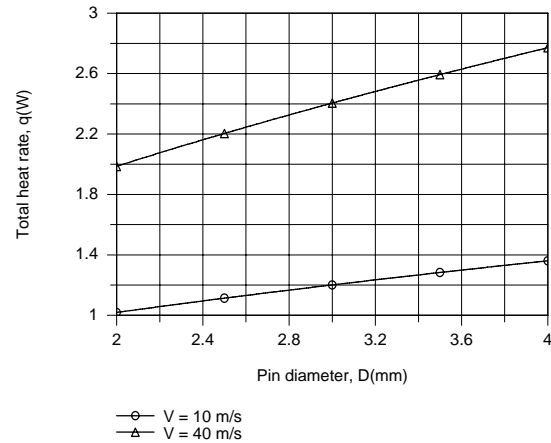
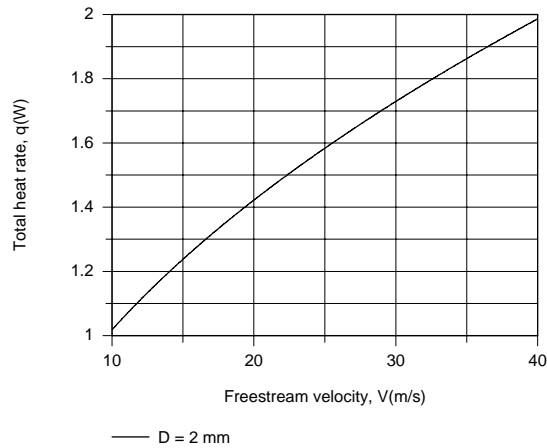

Clearly, there is significant benefit associated with increasing  $V$  which increases the convection coefficient and the total heat rate. Although the convection coefficient decreases with increasing  $D$ , the increase in the total heat transfer surface area is sufficient to yield an increase in  $q$  with increasing  $D$ . The maximum heat rate is  $q = 2.77 \text{ W}$  for  $V = 40 \text{ m/s}$  and  $D = 4 \text{ mm}$ .

**COMMENTS:** Radiation effects should be negligible, although tip and base convection coefficients will differ from those calculated in parts (a) and (d).

## PROBLEM 7.55

**KNOWN:** Diameter, resistivity, thermal conductivity and emissivity of Nichrome wire. Electrical current. Temperature of air flow and surroundings. Velocity of air flow.

**FIND:** (a) Surface and centerline temperatures of the wire, (b) Effect of flow velocity and electric current on temperatures.

**SCHEMATIC:**

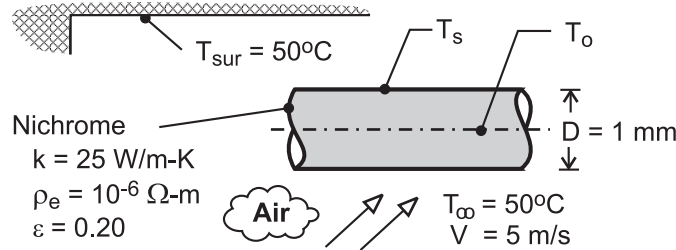

**ASSUMPTIONS:** (1) Steady-state, (2) Radiation exchange with large surroundings, (3) Constant Nichrome properties, (4) Uniform surface temperature.

**PROPERTIES:** Prescribed, Nichrome:  $k = 25 \text{ W/m}\cdot\text{K}$ ,  $\rho_e = 10^{-6} \Omega\cdot\text{m}$ ,  $\varepsilon = 0.2$ . *Table A-4*, air ( $T_f \approx 800\text{K}$ :  $k_a = 0.057 \text{ W/m}\cdot\text{K}$ ,  $\nu = 8.5 \times 10^{-5} \text{ m}^2/\text{s}$ ,  $\text{Pr} = 0.71$ ).

**ANALYSIS:** (a) The surface temperature may be obtained from Eq. 3.60, with  $\bar{h} = \bar{h}_c + h_r$  and

$$\dot{q} = I^2 R_e / \forall = I^2 \rho_e / A_c^2 = I^2 \rho_e / (\pi D^2 / 4)^2 = 1.013 \times 10^9 \text{ W/m}^3.$$

$$T_s = T_\infty + \frac{\dot{q}(D/2)}{2(\bar{h}_c + h_r)} \quad (1)$$

The convection coefficient is obtained from the Churchill and Bernstein correlation

$$\bar{h}_c = \frac{k_a}{D} \left\{ 0.3 + \frac{0.62 \text{Re}_D^{1/2} \text{Pr}^{1/3}}{\left[1 + (0.4/\text{Pr})^{2/3}\right]^{1/4}} \left[1 + \left(\frac{\text{Re}_D}{282,000}\right)^{5/8}\right]^{4/5} \right\} = 230 \text{ W/m}^2 \cdot \text{K}$$

where  $\text{Re}_D = VD/\nu = 58.8$ , and the radiation coefficient is obtained from Eq. 1.9

$$h_r = \varepsilon \sigma (T_s + T_{\text{sur}}) (T_s^2 + T_{\text{sur}}^2) \quad (2)$$

From an iterative solution of Eqs. (1) and (2), we obtain

$$T_s \approx 1285\text{K} = 1012^\circ\text{C} \quad <$$

From Eq. 3.58, the centerline temperature is

$$T_o = \frac{\dot{q}(D/2)^2}{4k} + T_s = \frac{1.013 \times 10^9 \text{ W/m}^3 (0.0005\text{m})^2}{100 \text{ W/m}\cdot\text{K}} + 1012^\circ\text{C} \approx 1014^\circ\text{C} \quad <$$

The centerline temperature is only approximately  $2^\circ\text{C}$  larger than the surface temperature, and the wire may be assumed to be isothermal.

Continued ...

### PROBLEM 7.55 (Cont.)

(b) Over the range  $1 \leq V < 100$  m/s for  $I = 25$  A,  $\bar{h}_c$  varies from approximately  $114 \text{ W/m}^2 \cdot \text{K}$  to  $1050 \text{ W/m}^2 \cdot \text{K}$ , while  $h_r$  varies from approximately  $69 \text{ W/m}^2 \cdot \text{K}$  to  $4 \text{ W/m}^2 \cdot \text{K}$ . The effect on the surface temperature is shown below.

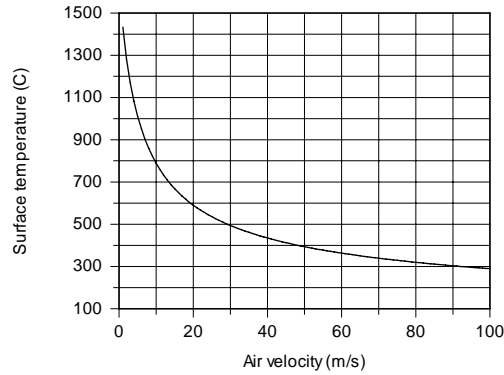

Maximum and minimum values of  $T_s = 1433^\circ\text{C}$  and  $T_s = 290^\circ\text{C}$  are associated with the smallest and largest velocities respectively, while the difference between the centerline and surface temperatures remains at  $(T_o - T_s) \approx 2^\circ\text{C}$ .

For  $V = 5$  m/s, the effect on  $T_s$  of varying the current over the range from 1 to 30 A is shown below.

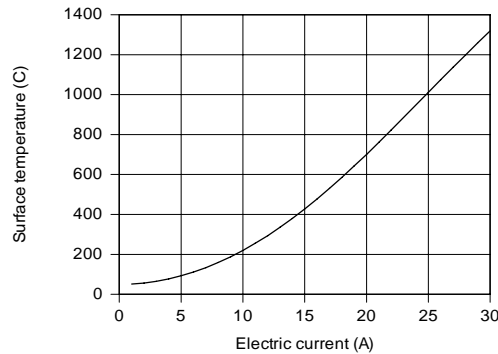

From a value of  $T_s \approx 52^\circ\text{C}$  at 1 A,  $T_s$  increases to  $1320^\circ\text{C}$  at 30 A. Over this range the temperature difference  $(T_o - T_s)$  increases from approximately  $0.01^\circ\text{C}$  to  $3^\circ\text{C}$ .

**COMMENTS:** (1) The radiation coefficient for the conditions of Part (a) is  $h_r = 32 \text{ W/m}^2 \cdot \text{K}$ , which is approximately 1/8 of the total coefficient  $\bar{h}$ . Hence, except for small values of  $V$  less than approximately 5 m/s, radiation is negligible compared with convection. (2) The small wire diameter and large thermal conductivity are responsible for maintaining nearly isothermal conditions within the wire. (3) The calculations of Part (b) were performed using the IHT solver with the function  $T_f = T_{\text{fluid\_avg}}(T_s, T_{\text{inf}})$  used to account for the effect of temperature on the air properties.

## PROBLEM 7.56

**KNOWN:** Diameter, thickness and thermal conductivity of steel pipe. Temperature of water flow in pipe. Temperature and velocity of air in cross flow over pipe. Cost of producing hot water.

**FIND:** (a) Cost of daily heat loss from an uninsulated pipe, (b) Savings associated with insulating the pipe.

**SCHEMATIC:**

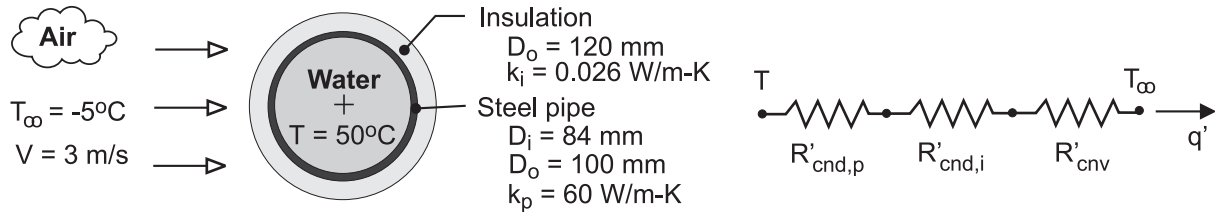

**ASSUMPTIONS:** (1) Steady-state, (2) Negligible convection resistance for water flow, (3) Negligible contact resistance between insulation and pipe, (4) Negligible radiation.

**PROPERTIES:** Table A-4, air ( $p = 1 \text{ atm}$ ,  $T_f \approx 300 \text{ K}$ ):  $k_a = 0.0263 \text{ W/m}\cdot\text{K}$ .

$$\nu = 15.89 \times 10^{-6} \text{ m}^2/\text{s}, \text{ Pr} = 0.707.$$

**ANALYSIS:** (a) With  $\text{Re}_D = VD_o/\nu = 3 \text{ m/s} \times 0.1 \text{ m} / 15.89 \times 10^{-6} \text{ m}^2/\text{s} = 18,880$ , application of the Churchill-Bernstein correlation yields

$$\overline{\text{Nu}}_D = 0.3 + \frac{0.62(18,880)^{1/2} (0.707)^{1/3}}{\left[1 + (0.4/0.707)^{2/3}\right]^{1/4}} \left[1 + \left(\frac{18,880}{282,000}\right)^{5/8}\right]^{4/5} = 76.6$$

$$\bar{h} = \frac{k_a}{D_o} \overline{\text{Nu}}_D = \frac{0.0263 \text{ W/m}\cdot\text{K}}{0.1 \text{ m}} 76.6 = 20.1 \text{ W/m}^2\cdot\text{K}$$

Without the insulation, the total thermal resistance and heat loss per length of pipe are then

$$\begin{aligned} R'_{\text{tot}(\text{wo})} &= \frac{\ln(D_o/D_i)}{2\pi k_p} + \frac{1}{\pi D_o \bar{h}} = \frac{\ln(100/84)}{2\pi \times 60 \text{ W/m}\cdot\text{K}} + \frac{1}{\pi (0.1 \text{ m}) 20.1 \text{ W/m}^2\cdot\text{K}} \\ &= (4.63 \times 10^{-4} + 0.158) \text{ m}\cdot\text{K/W} = 0.159 \text{ m}\cdot\text{K/W} \end{aligned}$$

$$q'_{\text{wo}} = \frac{T - T_\infty}{R'_{\text{tot}(\text{wo})}} = \frac{55^\circ\text{C}}{0.159 \text{ m}\cdot\text{K/W}} = 346 \text{ W/m} = 0.346 \text{ kW/m}$$

The corresponding daily energy loss is

$$Q'_{\text{wo}} = 0.346 \text{ kW/m} \times 24 \text{ h/d} = 8.3 \text{ kW}\cdot\text{h/m}\cdot\text{d}$$

and the associated cost is

$$C'_{\text{wo}} = (8.3 \text{ kW}\cdot\text{h/m}\cdot\text{d})(\$0.05/\text{kW}\cdot\text{h}) = \$0.415/\text{m}\cdot\text{d}$$

<

(b) The conduction resistance of the insulation is

Continued ...

**PROBLEM 7.56 (Cont.)**

$$R'_{\text{cnd}} = \frac{\ln(D_o/D_i)}{2\pi k_i} = \frac{\ln(120/100)}{2\pi(0.026 \text{ W/m}\cdot\text{K})} = 1.116 \text{ m}\cdot\text{K/W}$$

Using the Churchill-Bernstein correlation with an outside diameter of  $D_o = 0.12\text{m}$ ,  $Re_D = 22,660$ ,  $\overline{Nu}_D = 83.9$  and  $\overline{h} = 18.4 \text{ W/m}^2\cdot\text{K}$ . The convection resistance is then

$$R'_{\text{cnv}} = \frac{1}{\pi D_o \overline{h}} = \frac{1}{\pi(0.12\text{m})18.4 \text{ W/m}^2\cdot\text{K}} = 0.144 \text{ m}\cdot\text{K/W}$$

and the total resistance is

$$R'_{\text{tot}(w)} = \left(4.63 \times 10^{-4} + 1.116 + 0.144\right) \text{ m}\cdot\text{K/W} = 1.261 \text{ m}\cdot\text{K/W}$$

The heat loss and cost are then

$$q'_w = \frac{T - T_\infty}{R'_{\text{tot}(w)}} = \frac{55^\circ\text{C}}{1.261 \text{ m}\cdot\text{K/W}} = 43.6 \text{ W/m} = 0.0436 \text{ kW/m}$$

$$C'_w = 0.0436 \text{ kW/m} \times 24 \text{ h/d} \times \$0.05/\text{kW}\cdot\text{h} = \$0.052/\text{m}\cdot\text{d}$$

The daily savings is then

$$S' = C'_{w0} - C'_w = \$0.363/\text{m}\cdot\text{d} \quad \leftarrow$$

**COMMENTS:** (1) The savings are significant, and the pipe should be insulated. (2) Assuming a negligible temperature drop across the pipe wall, a pipe emissivity of  $\epsilon_p = 0.6$  and surroundings at  $T_{\text{sur}} = 268\text{K}$ , the radiation coefficient associated with the uninsulated pipe is  $h_r = \epsilon\sigma(T + T_{\text{sur}})(T^2 + T_{\text{sur}}^2) = 0.6 \times 5.67 \times 10^{-8} \text{ W/m}^2\cdot\text{K}^4 (591\text{K}) (323^2 + 268^2) \text{ K}^2 = 3.5 \text{ W/m}^2\cdot\text{K}$ . Accordingly, radiation increases the heat loss estimate of Part (a) by approximately 17%.

## PROBLEM 7.57

**KNOWN:** Dimension and initial temperature of long aluminum rods of square cross-section. Velocity and temperature of air in cross flow. Rod emissivity and surroundings temperature.

**FIND:** Which orientation of the rod relative to the cross flow should be used to minimize the time needed for the rods to reach a temperature of 60°C. Required cooling time for preferred configuration.

**SCHEMATIC:**

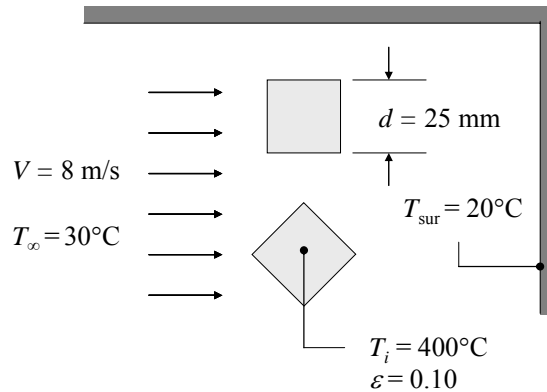

**ASSUMPTIONS:** (1) Constant properties.

**PROPERTIES:** Table A-4, Air ( $T = 400$  K):  $\nu = 26.41 \times 10^{-6} \text{ m}^2/\text{s}$ ,  $k = 0.0338 \text{ W/m}\cdot\text{K}$ ,  $Pr = 0.690$ .  
Table A-1, Pure aluminum ( $T = 500$  K):  $\rho_s = 2702 \text{ kg/m}^3$ ,  $c_{p,s} = 991 \text{ J/kg}\cdot\text{K}$ ,  $k_s = 235 \text{ W/m}\cdot\text{K}$ .

**ANALYSIS:** The heat transfer coefficient can be calculated from Equation 7.52, with the dimension  $D$  defined differently for the two configurations, as shown in Table 7.3. When the air flows perpendicular to a face of the rod,

$D = d = 0.025 \text{ m}$ ,  $Re_D = VD/\nu = 8 \text{ m/s} \times 0.025 \text{ m}/26.41 \times 10^{-6} \text{ m}^2/\text{s} = 7573$ , and from Table 7.3,  $C = 0.158$  and  $m = 0.66$ . Thus,

$$\bar{h} = \frac{k}{D} C Re_D^m Pr^{1/3} = \frac{0.0338 \text{ W/m}\cdot\text{K}}{0.025 \text{ m}} 0.158 (7573)^{0.66} (0.69)^{1/3} = 68.6 \text{ W/m}^2 \cdot \text{K}$$

When the rod is rotated so that it presents an edge to the flow,  $D = 2^{1/2}d = 2^{1/2} \times 0.025 \text{ m} = 0.0354 \text{ m}$ ,  $Re_D = VD/\nu = 8 \text{ m/s} \times 0.0354 \text{ m}/26.41 \times 10^{-6} \text{ m}^2/\text{s} = 10,710$ , and from Table 7.3,  $C = 0.304$  and  $m = 0.59$ . Thus,

$$\bar{h} = \frac{k}{D} C Re_D^m Pr^{1/3} = \frac{0.0338 \text{ W/m}\cdot\text{K}}{0.0354 \text{ m}} 0.304 (10,710)^{0.59} (0.69)^{1/3} = 61.2 \text{ W/m}^2 \cdot \text{K}$$

Radiation will affect both rods in the same way, therefore the rod with the larger value of convection heat transfer coefficient will cool faster. The rod should be oriented with a face perpendicular to the flow in order to minimize the cooling time. <

The importance of radiation can be estimated by calculating the radiation heat flux at the initial time,  $q_{\text{rad}}'' = \epsilon \sigma (T_s^4 - T_{\text{sur}}^4) = 0.1 \times 5.67 \times 10^{-8} \text{ W/m}^2 \cdot \text{K}^4 \times [(673 \text{ K})^4 - (293 \text{ K})^4] = 1120 \text{ W/m}^2$ . The initial convection heat transfer flux is  $q_{\text{conv}}'' = \bar{h} (T_s - T_{\infty}) = 68.6 \text{ W/m}^2 \cdot \text{K} \times (400^\circ\text{C} - 30^\circ\text{C}) = 25,380 \text{ W/m}^2$ . Since the radiation heat transfer rate is only around 4% initially, and will decrease in relative importance with time, radiation can be neglected in a calculation of the cooling time.

Continued...



### PROBLEM 7.57 (Cont.)

The cooling process can be modeled using the lumped capacitance approximation, provided the Biot number is small. Using a characteristic length of  $L = V/A_s = d/4 = 0.00625$  m, the Biot number is

$$Bi = \frac{\bar{h}L}{k} = \frac{68.6 \text{ W/m}^2 \cdot \text{K} \times 0.00625 \text{ m}}{235 \text{ W/m} \cdot \text{K}} = 0.0018$$

Therefore, the lumped capacitance approximation is valid and the cooling time is given by Equation 5.5,

$$t = \frac{\rho Vc}{hA_s} \ln \frac{\theta_i}{\theta} = \frac{\rho dc}{4\bar{h}} \ln \frac{T_i - T_\infty}{T - T_\infty} = \frac{2702 \text{ kg/m}^3 \times 0.025 \text{ m} \times 991 \text{ J/kg} \cdot \text{K}}{4 \times 68.6 \text{ W/m}^2 \cdot \text{K}} \ln \left( \frac{400 - 30}{60 - 30} \right) = 613 \text{ s} <$$

**COMMENTS:** *IHT* was used to solve this problem including the effect of radiation. The required cooling time, including radiation, is 601 s. Inclusion of radiation has a minor effect on the cooling time, as expected.

### PROBLEM 7.58

**KNOWN:** Temperature and heat dissipation in a wire of diameter  $D$ .

**FIND:** (a) Expression for flow velocity over wire, (b) Velocity of airstream for prescribed conditions.

**SCHEMATIC:**

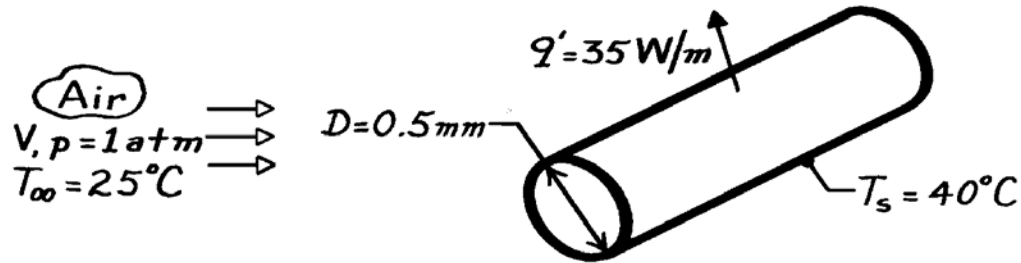

**ASSUMPTIONS:** (1) Steady-state conditions, (2) Uniform wire temperature, (3) Negligible radiation.

**PROPERTIES:** Table A-4, Air ( $T_\infty = 298 \text{ K}$ , 1 atm):  $\nu = 15.8 \times 10^{-6} \text{ m}^2/\text{s}$ ,  $k = 0.0262 \text{ W/m}\cdot\text{K}$ ,  $\text{Pr} = 0.71$ ; ( $T_s = 313 \text{ K}$ , 1 atm):  $\text{Pr} = 0.705$ .

**ANALYSIS:** (a) The rate of heat transfer per unit cylinder length is

$$q' = (q/L) = \bar{h}(\pi D) (T_s - T_\infty)$$

where, from the Zhukauskas relation, with  $\text{Pr} \approx \text{Pr}_s$ ,

$$\bar{h} = \frac{k}{D} C \text{Re}_D^m \text{Pr}^n = \frac{k}{D} C \left( \frac{VD}{\nu} \right)^m \text{Pr}^n$$

Hence,

$$V = \left[ \frac{q'}{(k/D) C \text{Pr}^n (\pi D) (T_s - T_\infty)} \right]^{1/m} \left( \frac{\nu}{D} \right). \quad <$$

(b) Assuming ( $10^3 < \text{Re}_D < 2 \times 10^5$ ),  $C = 0.26$ ,  $m = 0.6$  from Table 7.4. Hence,

$$V = \left[ \frac{35 \text{ W/m}}{0.0262 \text{ W/m}\cdot\text{K} \times 0.26 (0.71)^{0.37} \pi (40 - 25)^\circ\text{C}} \right]^{1/0.6} \left( \frac{15.8 \times 10^{-6} \text{ m}^2/\text{s}}{5 \times 10^{-4} \text{ m}} \right)$$

$$V = 97 \text{ m/s}. \quad <$$

To verify the assumption of the Reynolds number range, calculate

$$\text{Re}_D = \frac{VD}{\nu} = \frac{97 \text{ m/s} (5 \times 10^{-4} \text{ m})}{15.8 \times 10^{-6} \text{ m}^2/\text{s}} = 3074.$$

Hence the assumption was correct.

**COMMENTS:** The major uncertainty associated with using this method to determine  $V$  is that associated with use of the correlation for  $\bar{\text{Nu}}_D$ .

## PROBLEM 7.59

**KNOWN:** Platinum wire maintained at a constant temperature in an airstream to be used for determining air velocity changes.

**FIND:** (a) Relationship between fractional changes in current to maintain constant wire temperature and fractional changes in air velocity and (b) Current required when air velocity is 10 m/s.

**SCHEMATIC:**

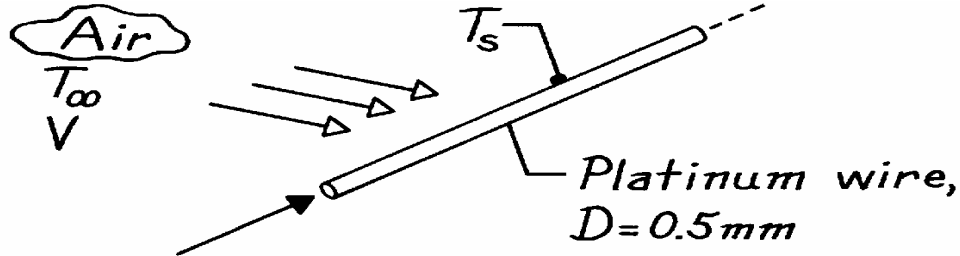

**ASSUMPTIONS:** (1) Steady-state conditions, (2) Cross-flow of air on wire with  $40 < Re_D < 1000$ , (3) Radiation effects negligible, (4) Wire is isothermal.

**PROPERTIES:** Platinum wire (given): Electrical resistivity,  $\rho_e = 17.1 \times 10^{-5}$  Ohm-m; *Table A-4*, Air ( $T_\infty = 27^\circ\text{C} = 300$  K, 1 atm):  $\nu = 15.89 \times 10^{-6}$  m<sup>2</sup>/s,  $k = 0.0263$  W/m-K,  $Pr = 0.707$ ; ( $T_s = 77^\circ\text{C} = 350$  K, 1 atm):  $Pr_s = 0.700$ .

**ANALYSIS:** (a) From an energy balance on a unit length of the platinum wire,

$$q'_{\text{elec}} - q'_{\text{conv}} = I^2 R'_e - \bar{h}P(T_s - T_\infty) = 0 \quad (1)$$

where the electrical resistance per unit length is  $R'_e = \rho_e / A_c$ ,  $P = \pi D$ , and  $A_c = \pi D^2 / 4$ . Hence,

$$I = \left[ \frac{\bar{h}P A_c}{\rho_e} (T_s - T_\infty) \right]^{1/2} = \left[ \frac{\pi^2 \bar{h} D^3}{4 \rho_e} (T_s - T_\infty) \right]^{1/2} \quad (2)$$

For the range  $40 < Re_D < 1000$ , using the Zhukauskas correlation for cross-flow over a cylinder with  $C = 0.51$  and  $m = 0.5$ ,

$$\overline{Nu}_D = \frac{\bar{h}D}{k} = 0.51 Re_D^{0.5} Pr^{0.37} \left( \frac{Pr}{Pr_s} \right)^{1/4} = 0.51 \left( \frac{VD}{\nu} \right)^{0.5} Pr^{0.37} \left( \frac{Pr}{Pr_s} \right)^{1/4} \quad (3)$$

note that  $\bar{h} \sim V^{0.5}$ , which, when substituted into Eq. (2) yields

$$I \sim \bar{h}^{1/2} = \left( V^{0.5} \right)^{1/2} = V^{1/4}.$$

Differentiating the proportionality and dividing the result by the proportionality, it follows that

$$\frac{\Delta I}{I} \approx \frac{1}{4} \frac{\Delta V}{V}. \quad (4) \quad <$$

(b) For air at  $T_\infty = 27^\circ\text{C}$  and  $V = 10$  m/s, the current required to maintain the wire of  $D = 0.5$  mm at  $T_s = 77^\circ\text{C}$  follows from Eq. (2) with  $\bar{h}$  evaluated by Eq. (3)

Continued ...

**PROBLEM 7.59 (Cont.)**

$$\bar{h} = \frac{0.0263 \text{ W/m} \cdot \text{K}}{0.0005 \text{ m}} \times 0.51 \left( \frac{10 \text{ m/s} \times 0.0005 \text{ m}}{15.89 \times 10^{-6} \text{ m}^2/\text{s}} \right)^{0.5} (0.707)^{0.37} \left( \frac{0.707}{0.700} \right)^{1/4}$$
$$\bar{h} = 420 \text{ W/m}^2 \cdot \text{K}$$

where  $\text{Re}_D = 315$ . Hence the required current is

$$I = \left[ \frac{\pi^2 \times 420 \text{ W/m}^2 \cdot \text{K} (0.0005 \text{ m})^3}{4 \times 17.1 \times 10^{-5} \Omega \cdot \text{m}} (77 - 27) \text{ K} \right]^{1/2} = 195 \text{ mA}. \quad (5)$$

**COMMENTS:** (1) To measure 1% fractional velocity change, a 0.25% fractional change in current must be measured according to Eq. (4). From Eq. (5), this implies that  $\Delta I = 0.0025I = 0.0025 \times 195 \text{ mA} = 488 \mu\text{A}$ . An electronic circuit with such measurement sensitivity requires care in its design.

(2) Instruments built on this principle to measure air velocities are called *hot-wire anemometers*. Generally, the wire diameters are much smaller (3 to 30  $\mu\text{m}$  vs 500  $\mu\text{m}$  of this problem) in order to have faster response times.

(3) What effect would the presence of radiation exchange between the wire and its surroundings have?

## PROBLEM 7.60

**KNOWN:** Hot film sensor on a quartz rod maintained at  $T_s = 50^\circ\text{C}$ .

**FIND:** (a) Compute and plot the convection coefficient as a function of velocity for water,  $0.5 \leq V_w \leq 5$  m/s, and air,  $1 \leq V_a \leq 20$  m/s with  $T_\infty = 20^\circ\text{C}$  and (b) Suitability of using the hot film sensor for the two fluids based upon Biot number considerations.

**SCHEMATIC:**

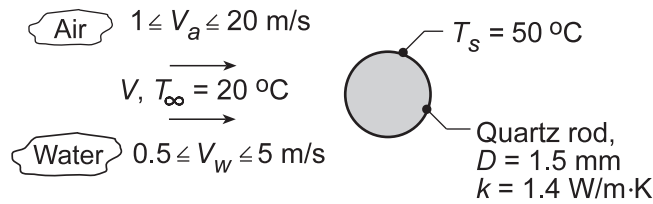

**ASSUMPTIONS:** (1) Cross-flow over a smooth cylinder, (2) Steady-state conditions, (3) Uniform surface temperature.

**PROPERTIES:** Table A.6, Water ( $T_f = 308$  K, sat liquid); Table A.4, Air ( $T_f = 308$  K, 1 atm).

**ANALYSIS:** (a) Using the *IHT Tool, Correlations, Cylinder*, along with the *Properties Tool* for Air and Water, results were obtained for the convection coefficients as a function of velocity.

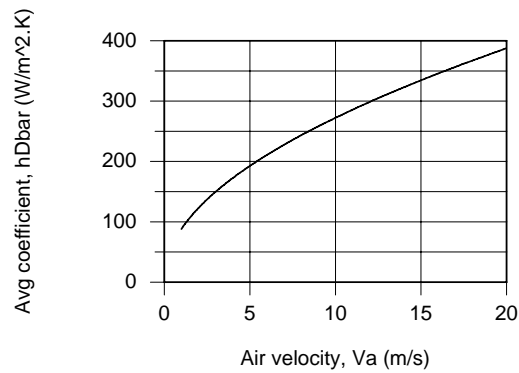
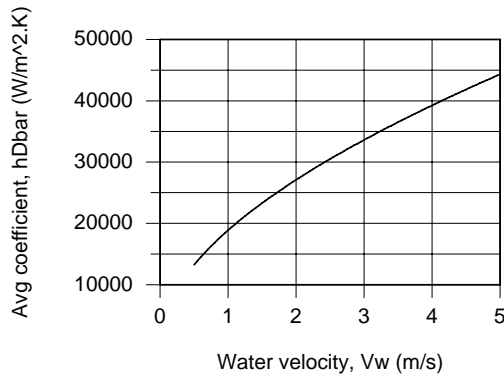

(b) The Biot number,  $hD/2k$ , is the ratio of the internal to external thermal resistances. When  $Bi \gg 1$ , the thin film is thermally coupled well to the fluid. When  $Bi \leq 1$ , significant power from the heater is dissipated axially by conduction in the rod. The Biot numbers for the fluids as a function of velocity are shown below.

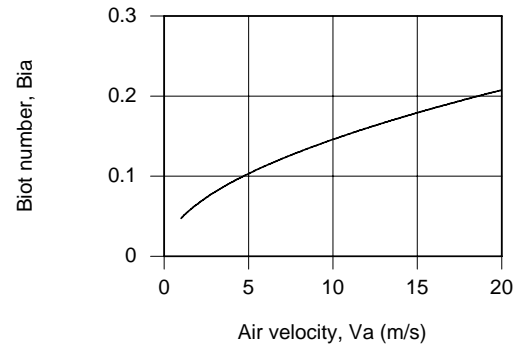
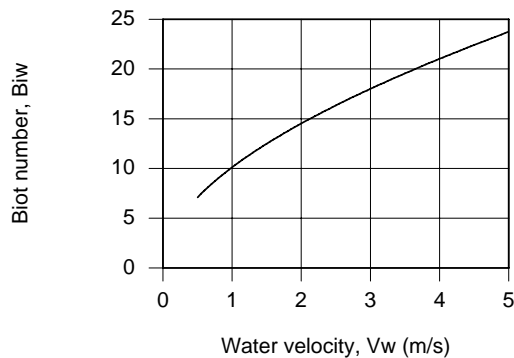

We conclude that the sensor is well suited for use with water, but not so for use with air.

Continued...

## PROBLEM 7.60 (Cont.)

**COMMENTS:** A copy of the IHT workspace developed to generate the above plots is shown below.

**// Problem 7.60**

**// Correlation Tool: External Flow, Cylinder**

/\* Correlation description: External cross flow (EF) over cylinder (CY), average coefficient,  $ReD^*Pr > 0.2$ , Churchill-Bernstein correlation, Eq 7.57. See Table 7.7. \*/

**// Air flow (a)**

$Nu_{Dbar} = Nu_{D\_bar\_EF\_CY}(ReDa, Pra)$  // Eq 7.54

$Nu_{Dbar} = h_{Dbar} * D / k_a$

$ReDa = Va * D / \nu_a$

// Evaluate properties at the film temperature,  $T_{fa}$ .

$T_f = (T_{inf} + T_s) / 2$

$Bi_a = h_{Dbar} * D / (2 * k)$  // Biot number

**// Properties Tool: Air**

// Air property functions : From Table A.4

// Units: T(K); 1 atm pressure

$\nu_a = \nu_{T}(\text{"Air"}, T_f)$  // Kinematic viscosity,  $m^2/s$

$k_a = k_{T}(\text{"Air"}, T_f)$  // Thermal conductivity, W/m-K

$Pra = Pr_{T}(\text{"Air"}, T_f)$  // Prandtl number

**// Water flow (w)**

$Nu_{Dbarw} = Nu_{D\_bar\_EF\_CY}(ReDw, Prw)$  // Eq 7.54

$Nu_{Dbarw} = h_{Dbarw} * D / k_w$

$ReDw = Vw * D / \nu_w$

// Evaluate properties at the film temperature,  $T_{fw}$ .

//  $T_{fw} = (T_{infw} + T_{sw}) / 2$

$Bi_w = h_{Dbarw} * D / (2 * k)$  // Biot number

**// Properties Tool: Water**

// Water property functions : T dependence, From Table A.6

// Units: T(K), p(bars); x = quality (0=sat liquid or 1=sat vapor)

$xf = 0$

$\nu_w = \nu_{Tx}(\text{"Water"}, T_f, xf)$  // Kinematic viscosity,  $m^2/s$

$k_w = k_{Tx}(\text{"Water"}, T_f, xf)$  // Thermal conductivity, W/m-K

$Prw = Pr_{Tx}(\text{"Water"}, T_f, xf)$  // Prandtl number

**// Assigned Variables:**

$Va = 1$  // Air velocity, m/s; range 1 to 20 m/s

$Vw = 0.5$  // Water velocity, m/s; range 0.5 to 5 m/s

$k = 1.4$  // Thermal conductivity, W/m.K; quartz rod

$D = 0.0015$  // Diameter, m

$T_s = 30 + 273$  // Surface temperature, K

$T_{inf} = 20 + 273$  // Fluid temperature, K

**/\* Solve, Explore and Graph:** After solving, separate Explore sweeps for  $1 \leq Va \leq 20$  and  $0.5 \leq Vw \leq 5$  m/s were performed saving results in different Data Sets. Four separate plot windows were generated. \*/

## PROBLEM 7.61

**KNOWN:** Diameter, temperature and heat flux of a hot-film sensor. Fluid temperature. Thickness and thermal conductivity of deposit.

**FIND:** (a) Fluid velocity, (b) Heat flux if sensor is coated by a deposit.

**SCHEMATIC:**

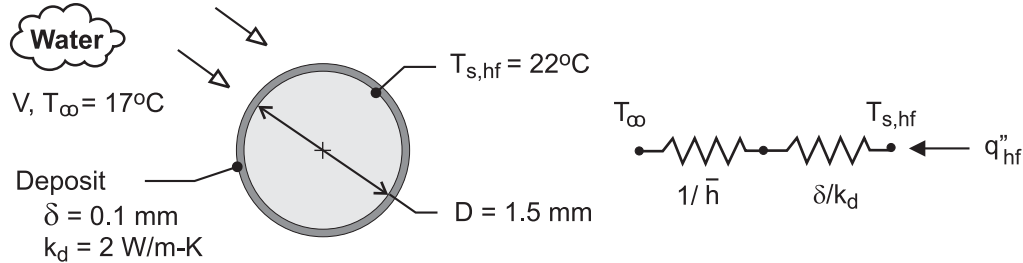

**ASSUMPTIONS:** (1) Steady-state, (2) Constant properties, (3) Thickness of hot film sensor is negligible, (4) Applicability of Churchill-Bernstein correlation for uniform surface heat flux, (5)  $Re_D \ll 282,000$ , (6) Deposit may be approximated as a plane layer.

**PROPERTIES:** Table A-6, water ( $T_f = 292.5\text{K}$ ):  $k = 0.602\text{ W/m}\cdot\text{K}$ ,  $\nu = 1.02 \times 10^{-6}\text{ m}^2/\text{s}$ ,  $Pr = 7.09$ .

**ANALYSIS:** (a) With  $Re_D \ll 282,000$  and  $\bar{h} = q''_{hf} / (T_{s,hf} - T_\infty)$ , Eq. (7.54) reduces to

$$\overline{Nu}_D = \frac{q''_{hf} D}{k(T_{s,hf} - T_\infty)} \approx 0.3 + \frac{0.62 Re_D^{1/2} Pr^{1/3}}{\left[1 + (0.4/Pr)^{2/3}\right]^{1/4}} \quad (1)$$

Substituting for  $D$ ,  $(T_{s,hf} - T_\infty)$ ,  $k$  and  $Pr$ ,

$$4.98 \times 10^{-4} q''_{hf} \approx 0.3 + 1.15 Re_D^{1/2}$$

or, with  $Re_D^{1/2} = (D/\nu)^{1/2} V^{1/2} = 38.3 V^{1/2}$ ,

$$4.98 \times 10^{-4} q''_{hf} \approx 0.3 + 44.1 V^{1/2} \quad (2)$$

Substituting for  $q''_{hf}$ ,

$$V = 0.20\text{ m/s} \quad <$$

(b) For a fixed value of  $T_{s,hf}$ , the thermal resistance of the deposit reduces  $q''_{hf}$ . From the thermal circuit.

$$q''_{hf} = \frac{T_{s,hf} - T_\infty}{(1/\bar{h}) + (\delta/k_d)}$$

Using Eq. (1) to evaluate  $\bar{h}$ ,

Continued ...

**PROBLEM 7.61 (Cont.)**

$$\bar{h} \approx \frac{k}{(D + \delta)} \left\{ 0.3 + \frac{0.62 \text{Re}_D^{1/2} \text{Pr}^{1/3}}{\left[ 1 + (0.4/\text{Pr})^{2/3} \right]^{1/4}} \right\}$$

where, with  $V = 0.20$  m/s,  $\text{Re}_D = V(D + \delta)/\nu = 314$ , we obtain

$$\bar{h} \approx \frac{0.602 \text{ W/m} \cdot \text{K}}{0.0016 \text{ m}} \{20.7\} = 7,780 \text{ W/m}^2 \cdot \text{K}$$

Hence, 
$$q''_{\text{hf}} = \frac{5^\circ\text{C}}{\left( 1.285 \times 10^{-4} + 0.5 \times 10^{-4} \right) \text{ m}^2 \cdot \text{K/W}} = 2.80 \times 10^4 \text{ W/m}^2 <$$

With the foregoing heat flux applied to the sensor and use of the model for Part (a), the sensor would indicate a velocity predicted from Eq. (2), or

$$V = \left[ \left( 4.98 \times 10^{-4} \times 2.80 \times 10^4 - 0.3 \right) / 44.1 \right]^2 = 0.096 \text{ m/s}$$

The error in the velocity measurement is therefore

$$\% \text{ Error} \equiv \frac{V_{(a)} - V_{(b)}}{V_{(a)}} (100\%) = \frac{0.20 - 0.096}{0.20} \times 100 = 52\% <$$

**COMMENTS:** (1) The accuracy of the hot-film sensor is strongly influenced by the deposit, and in any such application it is important to maintain a clean surface. (2) The Reynolds numbers are much less than 282,000 and assumption 5 is valid.



## PROBLEM 7.62

**KNOWN:** Dimensions of a flat plate in parallel flow. Plate and air temperatures and air velocity. Dimensions of a horizontal cylinder.

**FIND:** Convective heat loss from top and bottom of the flat plate and from the cylinder.

**SCHEMATIC:**

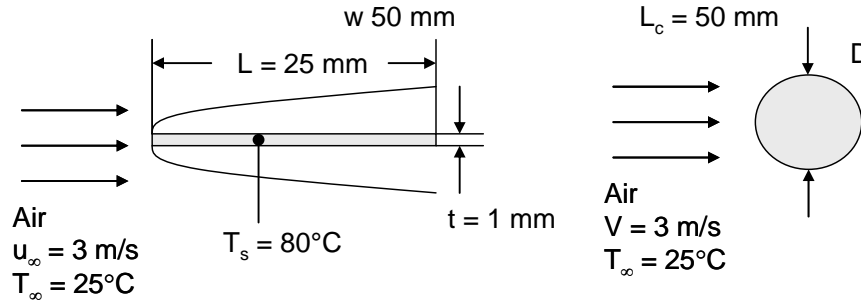

**ASSUMPTIONS:** (1) Steady-state conditions, (2) Constant properties.

**PROPERTIES:** Table A.4, air ( $T_f = (80^\circ\text{C} + 25^\circ\text{C})/2 = 52.5^\circ\text{C} \approx 325\text{K}$ ,  $p = 1\text{ atm}$ ):  $\nu = 18.4 \times 10^{-6}\text{ m}^2/\text{s}$ ,  $Pr = 0.704$ ,  $k = 0.0282\text{ W/m}\cdot\text{K}$ .

**ANALYSIS:** For the plate,

$$Re_L = \frac{u_\infty L}{\nu} = \frac{3\text{ m/s} \times 25 \times 10^{-3}\text{ m}}{18.4 \times 10^{-6}\text{ m}^2/\text{s}} = 4076$$

Therefore, the flow is laminar and Eq. 7.30 yields

$$\bar{h} = \frac{k}{L} \left[ 0.664 Re_L^{1/2} \right] Pr^{1/3} = \frac{0.0282\text{ W/m}\cdot\text{K}}{25 \times 10^{-3}\text{ m}} \left[ 0.664 \times 4076^{1/2} \right] 0.704^{1/3} = 42.5\text{ W/m}^2 \cdot \text{K}$$

and the convective heat transfer rate from the top and bottom of the flat plate is

$$q = 2wLh(T_s - T_\infty) = 2 \times 50 \times 10^{-3}\text{ m} \times 25 \times 10^{-3}\text{ m} \times 42.5\text{ W/m}^2 \cdot \text{K} (80 - 25)^\circ\text{C} = 5.84\text{ W} \quad \leftarrow$$

For the cylinder,  $D = \sqrt{\frac{4}{\pi} tL} = \sqrt{\frac{4}{\pi} \times 1 \times 10^{-3}\text{ m} \times 25 \times 10^{-3}\text{ m}} = 0.00564\text{ m} = 5.64\text{ mm}$  and

$$Re_D = \frac{VD}{\nu} = \frac{3\text{ m/s} \times 5.64 \times 10^{-3}\text{ m}}{18.4 \times 10^{-6}\text{ m}^2/\text{s}} = 920$$

Equation 7.54 yields

$$\begin{aligned} \bar{Nu}_D &= 0.3 + \frac{0.62 Re_D^{1/2} Pr^{1/3}}{\left[ 1 + (0.4/Pr)^{2/3} \right]^{1/4}} \left[ 1 + \left( \frac{Re_D}{282,000} \right)^{5/8} \right]^{4/5} \\ &= 0.3 + \frac{0.62 \times 920^{1/2} \times 0.704^{1/3}}{\left[ 1 + (0.4/0.704)^{2/3} \right]^{1/4}} \left[ 1 + \left( \frac{920}{282,000} \right)^{5/8} \right]^{4/5} = 15.3 \end{aligned}$$

Continued...

### PROBLEM 7.62 (Cont.)

and 
$$\bar{h} = \frac{\overline{Nu_D} k}{D} = \frac{15.3 \times 0.0282 \text{ W/m} \cdot \text{K}}{5.64 \times 10^{-3} \text{ m}} = 76.5 \text{ W/m}^2 \cdot \text{K}$$

Therefore, the heat transfer rate from the cylinder is,

$$q = \pi D L_c \bar{h} (T_s - T_\infty) = \pi \times 5.64 \times 10^{-3} \text{ m} \times 50 \times 10^{-3} \text{ m} \times 76.52 \text{ W/m}^2 \cdot \text{K} (80 - 25)^\circ \text{C} = 3.73 \text{ W} \quad <$$

**COMMENTS:** (1) The heat transfer coefficient associated with the cylinder is 80% greater than that associated with the flat plate. However, for the same volume, the exposed surface area of the cylinder is 65% smaller than that of the flat plate, resulting in an overall smaller heat transfer rate for the cylinder. (2) A trial-and-error solution reveals that a larger cylinder of diameter  $D = 13.6$  mm is necessary to transfer the same amount of energy by convection as the flat plate.

## PROBLEM 7.63

**KNOWN:** Dimensions of a rectangular fin in parallel flow. Circular pin fin of same cross-sectional area.

**FIND:** (a) Fin heat transfer rate for both fins. (b) Diameter of cylindrical fin needed to produce the same fin heat transfer rate as for the rectangular fin.

**SCHEMATIC:**

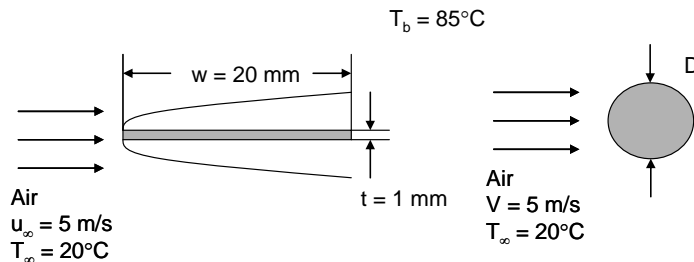

Cross-sectional views of the rectangular fin (left) and the cylindrical fin (right).  $T_b = 85^\circ\text{C}$ .

**ASSUMPTIONS:** (1) Steady-state conditions, (2) Constant properties, (3) Infinite fins, (4) Uniform heat transfer coefficients, equal to the average values.

**PROPERTIES:** Table A.4, air ( $T_f = (85^\circ\text{C} + 20^\circ\text{C})/2 = 52.5^\circ\text{C} \approx 325\text{K}$ ,  $p = 1\text{ atm}$ ):  $\nu = 18.4 \times 10^{-6}\text{ m}^2/\text{s}$ ,  $Pr = 0.704$ ,  $k = 0.0282\text{ W/m}\cdot\text{K}$ .

**ANALYSIS:** (a) For the rectangular fin,

$$Re_w = \frac{u_\infty w}{\nu} = \frac{5\text{ m/s} \times 20 \times 10^{-3}\text{ m}}{18.4 \times 10^{-6}\text{ m}^2/\text{s}} = 5435$$

Therefore, the flow is laminar and Eq. 7.30 yields

$$\bar{h} = \frac{k}{w} \left[ 0.664 Re_w^{1/2} \right] Pr^{1/3} = \frac{0.0282\text{ W/m}\cdot\text{K}}{20 \times 10^{-3}\text{ m}} \left[ 0.664 \times 5435^{1/2} \right] 0.704^{1/3} = 61.4\text{ W/m}^2 \cdot \text{K}$$

The periphery of the fin is  $P = 2(w + t) = 2 \times (20 \times 10^{-3}\text{ m} + 1 \times 10^{-3}\text{ m}) = 42 \times 10^{-3}\text{ m}$  and the cross-sectional area is  $A_c = wt = 20 \times 10^{-3}\text{ m} \times 1 \times 10^{-3}\text{ m} = 20 \times 10^{-6}\text{ m}^2$ . Evaluating the fin parameter  $M$  yields

$$M = \sqrt{hPkA_c} \theta_b = \sqrt{61.4\text{ W/m}^2 \cdot \text{K} \times 42 \times 10^{-3}\text{ m} \times 237\text{ W/m}\cdot\text{K} \times 20 \times 10^{-6}\text{ m}^2} \times (85 - 20)^\circ\text{C} = 7.19\text{ W}$$

For an infinite fin,

$$q_f = M = 7.19\text{ W} \quad \leftarrow$$

For the cylindrical fin,  $D = \sqrt{\frac{4}{\pi} tw} = \sqrt{\frac{4}{\pi} \times 1 \times 10^{-3}\text{ m} \times 20 \times 10^{-3}\text{ m}} = 0.00505\text{ m} = 5.05\text{ mm}$  and

$$Re_D = \frac{VD}{\nu} = \frac{5\text{ m/s} \times 5.05 \times 10^{-3}\text{ m}}{18.4 \times 10^{-6}\text{ m}^2/\text{s}} = 1372$$

Continued...

### PROBLEM 7.63 (Cont.)

Equation 7.54 yields

$$\begin{aligned}\overline{Nu}_D &= 0.3 + \frac{0.62 Re_D^{1/2} Pr^{1/3}}{\left[1 + (0.4/Pr)^{2/3}\right]^{1/4}} \left[1 + \left(\frac{Re_D}{282,000}\right)^{5/8}\right]^{4/5} \\ &= 0.3 + \frac{0.62 \times 1372^{1/2} \times 0.704^{1/3}}{\left[1 + (0.4/0.704)^{2/3}\right]^{1/4}} \left[1 + \left(\frac{1372}{282,000}\right)^{5/8}\right]^{4/5} = 18.7\end{aligned}$$

and 
$$\bar{h} = \frac{\overline{Nu}_D k}{D} = \frac{18.7 \times 0.0282 \text{ W/m} \cdot \text{K}}{5.05 \times 10^{-3} \text{ m}} = 104.4 \text{ W/m}^2 \cdot \text{K}$$

The periphery of the fin is  $P = \pi D = \pi \times 5.05 \times 10^{-3} \text{ m} = 15.9 \times 10^{-3} \text{ m}$  and the cross-sectional area is  $A_c = 20 \times 10^{-6} \text{ m}^2$ . Evaluating the fin parameter  $M$  yields

$$M = \sqrt{h P k A_c} \theta_b = \sqrt{104.4 \text{ W/m}^2 \cdot \text{K} \times 15.9 \times 10^{-3} \text{ m} \times 237 \text{ W/m} \cdot \text{K} \times 20 \times 10^{-6} \text{ m}^2} \times (85 - 20)^\circ\text{C} = 5.77 \text{ W}$$

For an infinite fin,

$$q_f = M = 5.77 \text{ W} \quad <$$

The rectangular fin heat rate is 25% greater than that of the cylindrical fin. <

(b) A trial-and-error solution shows that a cylinder diameter of  $D = 6.02 \text{ mm}$  is necessary to transfer the same amount of heat as the rectangular fin. <

**COMMENTS:** (1) The Reynolds number and heat transfer coefficient associated with part (b) are 1636 and  $96.0 \text{ W/m}^2 \cdot \text{K}$ , respectively. (2) The ratio of the mass of the cylinder in part (b) to that of the cylinder in part (a) is  $r = (D_b^2 / D_a^2) = (6.02 / 5.05)^2 = 1.42$ . Good thermal design, such as use of the rectangular fin rather than the cylindrical fin, can help conserve both natural resources and energy that is used to produce the aluminum.

## PROBLEM 7.64

**KNOWN:** Temperature sensor of 12.5 mm diameter experiences cross-flow of water at 80°C and velocity,  $0.005 < V < 0.20$  m/s. Sensor temperature may vary over the range  $20 < T_s < 80^\circ\text{C}$ .

**FIND:** Expression for convection heat transfer coefficient as a function of  $T_s$  and  $V$ .

**SCHEMATIC:**

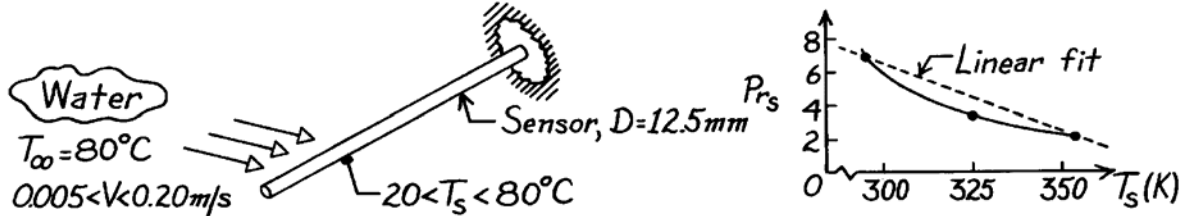

**ASSUMPTIONS:** (1) Steady-state conditions, (2) Sensor-water flow approximates a cylinder in cross-flow, (3) Prandtl number varies linearly with temperature over the range of interest.

**PROPERTIES:** Table A-6, Sat. water ( $T_\infty = 80^\circ\text{C} = 353$  K):  $k = 0.670$  W/m·K,  $\nu = \mu v_f = 352 \times 10^{-6}$  N·s/m<sup>2</sup>  $\times 1.029 \times 10^{-3}$  m<sup>3</sup>/kg =  $3.621 \times 10^{-7}$  m<sup>2</sup>/s;  $Pr_s$  values for  $20 \leq T_s \leq 80^\circ\text{C}$ :

T (K)	293	300	325	350	353
Pr	7.00	5.83	3.42	2.29	2.20

**ANALYSIS:** Using the Zhukauskus correlation for the range  $40 < Re_D < 4000$  with  $C = 0.51$  and  $m = 0.5$ ,

$$\overline{Nu}_D = \frac{\bar{h}D}{k} = 0.51 Re_D^{0.5} Pr^{0.37} \left( \frac{Pr}{Pr_s} \right)^{1/4}$$

with  $Re_D = VD/\nu$ , the thermophysical properties of interest are  $k$ ,  $\nu$  and  $Pr$ , which are evaluated at  $T_\infty = 80^\circ\text{C}$ , and  $Pr_s$  which varies markedly with  $T_s$  for the range  $20 < T_s < 80^\circ\text{C}$ . Assuming  $Pr_s$  to vary linearly with  $T_s$  and using the extreme values to find the relation,

$$Pr_s = 7.00 + \frac{(2.20 - 7.00)}{(353 - 293) \text{ K}} (T_s - 293) \text{ K} = 7.00 - 0.0800(T_s - 293)$$

where the units of  $T_s$  are [K]. Substituting numerical values, find

$$\bar{h}(T_s) = \frac{0.670 \text{ W/m}\cdot\text{K}}{0.0125 \text{ m}} 0.51 \left( \frac{V \times 0.0125 \text{ m}}{3.621 \times 10^{-7} \text{ m}^2/\text{s}} \right)^{0.5} (2.20)^{0.37} \left( \frac{2.20}{7.00 - 0.080(T_s - 293)} \right)^{1/4}$$

$$\bar{h}(T_s) = 6800V^{0.5} [3.182 - 0.0364(T_s - 293)]^{-1/4} \quad <$$

**COMMENTS:** (1) From the  $Pr_s$  vs  $T_s$  graph above, a linear fit is seen to be poor for this temperature range. However, because the  $Pr_s$  dependence is to the  $1/4$  power, the discrepancy may be acceptable.

## PROBLEM 7.65

**KNOWN:** Diameter, electrical resistance and current for a high tension line. Velocity and temperature of ambient air.

**FIND:** (a) Surface and (b) Centerline temperatures of the wire, (c) Effect of air velocity on surface temperature.

**SCHEMATIC:**

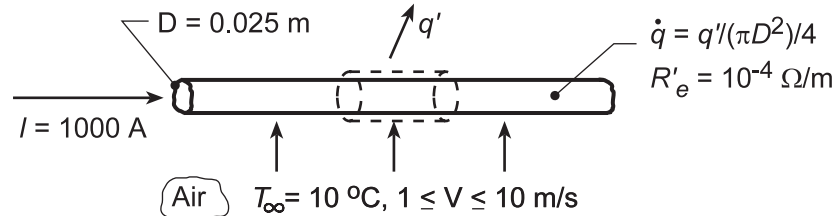

**ASSUMPTIONS:** (1) Steady-state conditions, (2) Constant properties, (3) One-dimensional radial conduction.

**PROPERTIES:** Table A.4, Air ( $T_f \approx 300$  K, 1 atm):  $\nu = 15.89 \times 10^{-6}$  m<sup>2</sup>/s,  $k = 0.0263$  W/m·K,  $Pr = 0.707$ ; Table A.1, Copper ( $T \approx 300$  K):  $k = 400$  W/m·K.

**ANALYSIS:** (a) Applying conservation of energy to a control volume of unit length,

$$\dot{E}'_g = I^2 R'_e = q' = \bar{h} \pi D (T_s - T_\infty)$$

With

$$Re_D = \frac{VD}{\nu} = \frac{10 \text{ m/s}(0.025 \text{ m})}{15.89 \times 10^{-6} \text{ m}^2/\text{s}} = 15,733$$

the Churchill and Bernstein correlation, yields

$$\overline{Nu}_D = 0.3 + \frac{0.62 Re_D^{1/2} Pr^{1/3}}{\left[1 + (0.4/Pr)^{2/3}\right]^{1/4}} \left[1 + \left(\frac{Re_D}{282,000}\right)^{5/8}\right]^{4/5} = 69.0$$

Hence,

$$\bar{h} = \overline{Nu}_D \frac{k}{D} = 69.0 \frac{0.0263 \text{ W/m} \cdot \text{K}}{0.025 \text{ m}} = 72.6 \text{ W/m}^2 \cdot \text{K}$$

and

$$T_s = T_\infty + \frac{I^2 R'_e}{\bar{h} \pi D} = 10^\circ \text{C} + \frac{(1000 \text{ A})^2 10^{-4} \Omega/\text{m}}{(72.6 \text{ W/m}^2 \cdot \text{K}) \pi (0.025 \text{ m})} = 10^\circ \text{C} + 17.6^\circ \text{C} = 27.6^\circ \text{C} \quad <$$

(b) With  $\dot{q} = \dot{E}'_g / (\pi D^2 / 4) = 4(1000 \text{ A})^2 (10^{-4} \Omega/\text{m}) / \pi (0.025 \text{ m})^2 = 2.04 \times 10^5 \text{ W/m}^3$ , Equation 3.58 yields

$$T(0) = \frac{\dot{q} r_0^2}{4k} + T_s = \frac{2.041 \times 10^5 \text{ W/m}^3 (0.0125 \text{ m})^2}{1600 \text{ W/m} \cdot \text{K}} + 27.6^\circ \text{C} = 0.02^\circ \text{C} + 27.6^\circ \text{C} \approx 27.6^\circ \text{C} \quad <$$

Continued...

### PROBLEM 7.65 (Cont.)

(c) The effect of  $V$  on the surface temperature was determined using the *Correlations and Properties* Tool Pads of IHT.

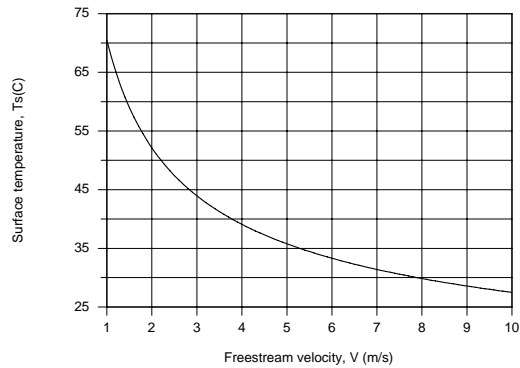

The effect is significant, with a surface temperature of  $T_s \approx 70^\circ\text{C}$  corresponding to  $V = 1$  m/s. For velocities of 1 and 10 m/s, respectively, convection coefficients are 21.1 and 72.8  $\text{W/m}^2\cdot\text{K}$  and film temperatures are 313.2 and 291.7 K.

**COMMENTS:** The small values of  $\dot{q}$  and  $r_o$  and the large value of  $k$  render the wire approximately isothermal.

## PROBLEM 7.66

**KNOWN:** Aluminum transmission line with a diameter of 20 mm having an electrical resistance of  $R' = 2.636 \times 10^{-4}$  ohm/m carrying a current of 700 A subjected to severe cross winds. To reduce potential fire hazard when adjacent lines make contact and spark, insulation is to be applied.

**FIND:** (a) The bare conductor temperature when the air temperature is  $20^\circ\text{C}$  and the line is subjected to cross flow with a velocity of 10 m/s; (b) The conductor temperature for the same conditions, but with an insulation covering of 2 mm thickness and thermal conductivity of  $0.15 \text{ W/m}\cdot\text{K}$ ; and (c) Plot the conductor temperatures of the bare and insulated conductors for wind velocities in the range of 2 to 20 m/s. Comment on the features of the curves and the effect that wind velocity has on the conductor operating temperatures.

**SCHEMATIC:**

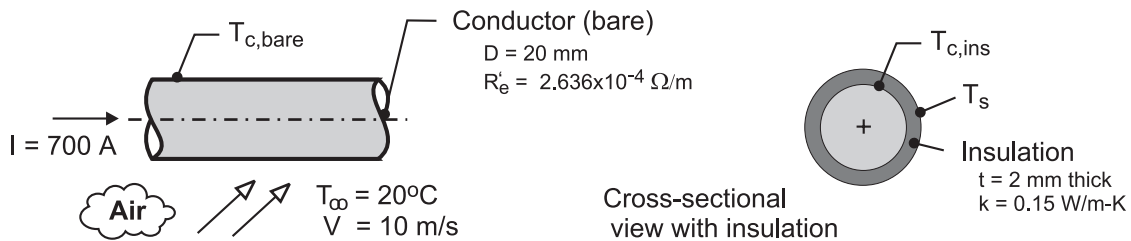

**ASSUMPTIONS:** (1) Steady-state conditions, (2) Uniform surface temperatures, (3) Negligible solar irradiation and radiation exchange, and (4) Constant properties.

**PROPERTIES:** Table A-4, Air ( $T_f = (T_s + T_\infty)/2$ , 1 atm): evaluated using the *IHT Properties* library with a *Correlation* function; see Comment 2.

**ANALYSIS:** (a) For the *bare* conductor the energy balance per unit length is

$$\begin{aligned} \dot{E}'_{\text{in}} - \dot{E}'_{\text{out}} + \dot{E}'_{\text{gen}} &= 0 \\ 0 - q'_{\text{cv}} + \dot{q} A_c &= 0 \end{aligned} \quad (1)$$

where the cross-sectional area of the conductor is  $A_c = \pi D^2/4$  and the generation rate is

$$\dot{q} = I^2 R'_e / A_c = (700 \text{ A})^2 \times 2.636 \times 10^{-4} \Omega / \text{m} / \left( \pi (0.020 \text{ m})^2 / 4 \right) \quad (2)$$

$$\dot{q} = 4.111 \times 10^5 \text{ W/m}^3$$

The convection rate equation can be expressed as

$$q'_{\text{cv}} = (T_{\text{c,bare}} - T_\infty) / R'_t \quad R'_t = 1 / (\bar{h}_D \times \pi D) \quad (3,4)$$

and the convection coefficient is estimated using the Churchill-Bernstein correlation, Eq. 7.54, with  $\text{Re}_D = VD/\nu$ ,

$$\overline{\text{Nu}}_L = \frac{\bar{h}_D D}{k} = 0.3 + \frac{0.62 \text{Re}_D^{1/2} \text{Pr}^{1/3}}{\left[ 1 + (0.4/\text{Pr})^{2/3} \right]^{1/4}} \left[ 1 + \left( \frac{\text{Re}_D}{282,000} \right)^{5/8} \right]^{4/5} \quad (4)$$

(b) For the conductor *with insulation* thickness  $t = 2$  mm, the energy balance per unit length is

$$\begin{aligned} \dot{E}'_{\text{in}} - \dot{E}'_{\text{out}} + \dot{E}'_{\text{gen}} &= 0 \\ 0 - (T_{\text{c,ins}} - T_\infty) / R'_t + I^2 R'_e / A_c &= 0 \end{aligned} \quad (5)$$

Continued ...



### PROBLEM 7.66 (Cont.)

where  $R'_t$  is the sum of the insulation conduction and convection process thermal resistances,

$$R'_t = \ln[(D+2t)/D]/(2\pi k) + 1/[\bar{h}_{D+2t}\pi(D+2t)] \quad (6)$$

The results of the analysis using *IHT* are tabulated below.

Condition	V (m/s)	D (mm)	Re <sub>D</sub>	$\bar{Nu}_D$	$\bar{h}_D$ (W/m <sup>2</sup> ·K)	R' <sub>t</sub> (m·K/W)	T <sub>c</sub> (°C)
bare	10	20	$1.214 \times 10^4$	59.6	79.6	0.1998	45.8
insulated	10	24	$1.468 \times 10^4$	66.3	73.6	0.3736	68.3

(c) Using the *IHT* code with the foregoing relations, the conductor temperatures  $T_{c,base}$  and  $T_{c,ins}$  for the bare and insulated conditions are calculated and plotted for the wind velocity range of 2 to 20 m/s.

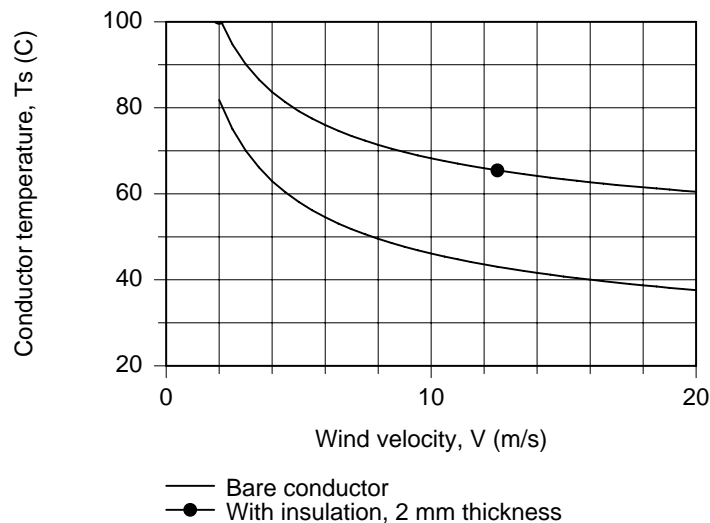

**COMMENTS:** (1) The effect of the 2-mm thickness insulation is to increase the conductor operating temperature by  $(68.3 - 46.1)^\circ\text{C} = 22^\circ\text{C}$ . While we didn't account for an increase in the electrical resistivity with increasing temperature, the adverse effect is to increase the  $I^2R$  loss, which represents a loss of revenue to the power provider. From the graph, note that the conductor temperature increases markedly with decreasing wind velocity, and the effect of insulation is still around  $+20^\circ\text{C}$ .

(2) Because of the tediousness of hand calculations required in using the convection correlation without fore-knowledge of  $T_f$  at which to evaluate properties, we used the *IHT Correlation* function treating  $T_f$  as one of the unknowns in the system of equations. Salient portions of the *IHT* code and property values are provided below.

Continued ...

## PROBLEM 7.66 (Cont.)

### // Forced convection, cross flow, cylinder

NuDbar = NuD\_bar\_EF\_CY(ReD,Pr) // Eq 7.54

NuDbar = hDbar \* Do / k

ReD = V \* Do / nu // Outer diameter; bare or with insulation

// Evaluate properties at the film temperature, Tf.

Tf = Tfluid\_avg (Tinf,Ts) // Ts is the outer surface temperature

/\* Correlation description: External cross flow (EF) over cylinder (CY), average coefficient, ReD\*Pr>0.2, Churchill-Bernstein correlation, Eq 7.54. See Table 7.9. \*/

### // Air property functions : From Table A.4

// Units: T(K); 1 atm pressure

nu = nu\_T("Air",Tf) // Kinematic viscosity, m<sup>2</sup>/s

k = k\_T("Air",Tf) // Thermal conductivity, W/m·K

Pr = Pr\_T("Air",Tf) // Prandtl number

(3) Is the temperature gradient within the conductor significant?

### PROBLEM 7.67

**KNOWN:** Velocities and temperatures of two air streams separated by a wall. Dimensions of an aluminum pin fin inserted through the wall. Distance it extends into the upper fluid.

**FIND:** (a) Heat transfer rate between the fluids via the pin fin, when it extends 50 mm into the upper fluid. (b) Heat transfer rate as a function of the distance it extends into the upper fluid.

**SCHEMATIC:**

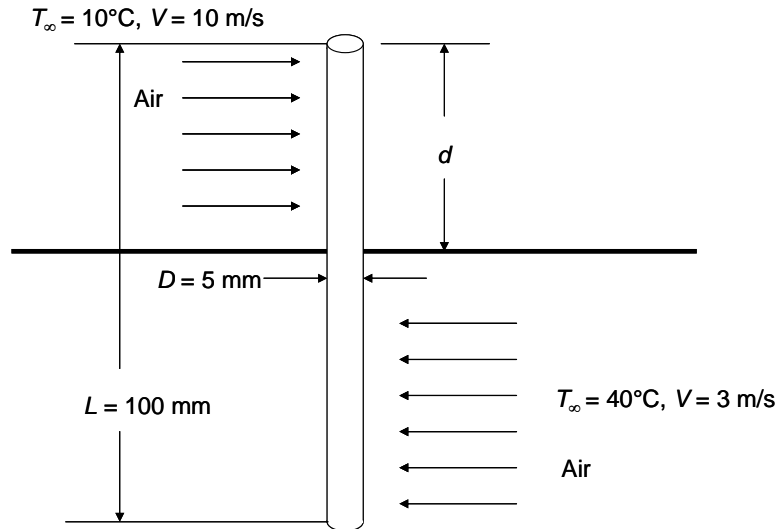

**ASSUMPTIONS:** (1) Velocity is uniform – decreased velocity near wall can be neglected, (2) For the purpose of evaluating properties, the fin temperature is equal to the average of the two fluid temperatures,  $T_s = 25^\circ\text{C}$ .

**PROPERTIES:** Table A-4, Air 1 ( $T_{f1} = 17.5^\circ\text{C} \cong 290.5 \text{ K}$ ):  $\nu_1 = 1.504 \times 10^{-5} \text{ m}^2/\text{s}$ ,  $k_1 = 0.02554 \text{ W/m}\cdot\text{K}$ ,  $\text{Pr}_1 = 0.710$ . Air 2 ( $T_{f2} = 32.5^\circ\text{C} \cong 305.5 \text{ K}$ ):  $\nu_2 = 1.644 \times 10^{-5} \text{ m}^2/\text{s}$ ,  $k_2 = 0.02671 \text{ W/m}\cdot\text{K}$ ,  $\text{Pr}_2 = 0.706$ . Table A-1, Aluminum 2024 ( $T_s = 25^\circ\text{C} \approx 300 \text{ K}$ ):  $k = 177 \text{ W/m}\cdot\text{K}$ .

**ANALYSIS:**

(a) The heat transfer coefficients between the air and the fin are analyzed as flow past a cylinder using the Churchill-Bernstein correlation:

$$\text{Re}_{D1} = \frac{V_1 D}{\nu_1} = \frac{10 \text{ m/s} \times 0.005 \text{ m}}{1.504 \times 10^{-5} \text{ m}^2/\text{s}} = 3320$$

$$\text{Re}_{D2} = \frac{V_2 D}{\nu_2} = \frac{3 \text{ m/s} \times 0.005 \text{ m}}{1.644 \times 10^{-5} \text{ m}^2/\text{s}} = 912.$$

From Equation 7.54,

$$\text{Nu}_{D1} = 0.3 + \frac{0.62 \text{Re}_{D1}^{1/2} \text{Pr}_1^{1/3}}{\left[1 + (0.4/\text{Pr}_1)^{2/3}\right]^{1/4}} \left[1 + \left(\frac{\text{Re}_{D1}}{282,000}\right)^{5/8}\right]^{4/5}$$

$$= 0.3 + \frac{0.62 \times (3320)^{1/2} \times (0.710)^{1/3}}{\left[1 + (0.4/0.710)^{2/3}\right]^{1/4}} \left[1 + \left(\frac{3320}{282,000}\right)^{5/8}\right]^{4/5} = 29.7$$

and 
$$h_1 = \frac{\text{Nu}_{D1} k_1}{D} = \frac{29.7 \times 0.02554 \text{ W/m}\cdot\text{K}}{0.005 \text{ m}} = 152 \text{ W/m}^2 \cdot \text{K}$$

Continued...

### PROBLEM 7.67 (Cont.)

Similarly,  $Nu_{D2} = 15.3$ ,  $h_2 = 81.5 \text{ W/m}^2\cdot\text{K}$ .

Next we analyze heat transfer along the rod as if it were two fins joined at their base – the location where the fin passes through the wall. Thus, using the corrected fin length approach, Equation 3.88,

$$\begin{aligned} q_1 &= M_1 \tanh m_1 L_{c1} \\ q_2 &= M_2 \tanh m_2 L_{c2} \end{aligned}$$

where

$$\begin{aligned} M_i &= \sqrt{h_i P k A_c} \theta_{bi} = \sqrt{h_i D k} \frac{\pi D}{2} (T_b - T_{\infty i}) \\ m_i &= \sqrt{h_i P / k A_c} = 2\sqrt{h_i / k D} \end{aligned}$$

and  $L_{ci} = L_i + D/4$ . In this expression,  $L_1 = d$  and  $L_2 = L - d$ . Finally, since heat leaving one rod enters the other,

$$\begin{aligned} q_1 &= -q_2 \\ \sqrt{h_1 D k} \frac{\pi D}{2} (T_b - T_{\infty 1}) \tanh m_1 L_{c1} &= -\sqrt{h_2 D k} \frac{\pi D}{2} (T_b - T_{\infty 2}) \tanh m_2 L_{c2} \end{aligned}$$

Solving for  $T_b$ :

$$T_b = \frac{\sqrt{h_1} T_{\infty 1} \tanh(m_1 L_{c1}) + \sqrt{h_2} T_{\infty 2} \tanh(m_2 L_{c2})}{\sqrt{h_1} \tanh(m_1 L_{c1}) + \sqrt{h_2} \tanh(m_2 L_{c2})} \quad (1)$$

We calculate

$$m_1 = 2\sqrt{h_1 / k D} = 2\sqrt{152 \text{ W/m}^2 \cdot \text{K} / (177 \text{ W/m} \cdot \text{K} \times 0.005 \text{ m})} = 26.2 \text{ m}^{-1}$$

and similarly,  $m_2 = 19.2 \text{ m}^{-1}$ . Also,  $L_{c1} = L_{c2} = d + D/4 = 0.05 \text{ m} + 0.005 \text{ m}/4 = 0.05125 \text{ m}$ .

Thus

$$\begin{aligned} T_b &= \frac{\left[ \sqrt{152 \text{ W/m}^2 \cdot \text{K}} \times 10^\circ\text{C} \times \tanh(26.2 \text{ m}^{-1} \times 0.05125 \text{ m}) \right. \\ &\quad \left. + \sqrt{81.5 \text{ W/m}^2 \cdot \text{K}} \times 40^\circ\text{C} \times \tanh(19.2 \text{ m}^{-1} \times 0.05125 \text{ m}) \right]}{\left[ \sqrt{152 \text{ W/m}^2 \cdot \text{K}} \times \tanh(26.2 \text{ m}^{-1} \times 0.05125 \text{ m}) \right. \\ &\quad \left. + \sqrt{81.5 \text{ W/m}^2 \cdot \text{K}} \times \tanh(19.2 \text{ m}^{-1} \times 0.05125 \text{ m}) \right]} = 21.6^\circ\text{C} \end{aligned}$$

Finally

$$\begin{aligned} q &= q_1 = -q_2 = \sqrt{h_1 D k} \frac{\pi D}{2} (T_b - T_{\infty 1}) \tanh(m_1 L_{c1}) \quad (2) \\ &= \sqrt{152 \text{ W/m}^2 \cdot \text{K} \times 0.005 \text{ m} \times 177 \text{ W/m} \cdot \text{K}} \times \frac{\pi(0.005 \text{ m})}{2} \\ &\quad \times (21.6^\circ\text{C} - 10^\circ\text{C}) \tanh(26.2 \text{ m}^{-1} \times 0.05125 \text{ m}) \\ &= 0.924 \text{ W} \end{aligned}$$

<  
Continued...

### PROBLEM 7.67 (Cont.)

(b) With  $L_{c1} = d + D/4$  and  $L_{c2} = L - d + D/4$ , we vary  $d$  in the range  $0 \leq d \leq 0.1$  m and solve Equations (1) and (2). The results for  $q$  are plotted below.

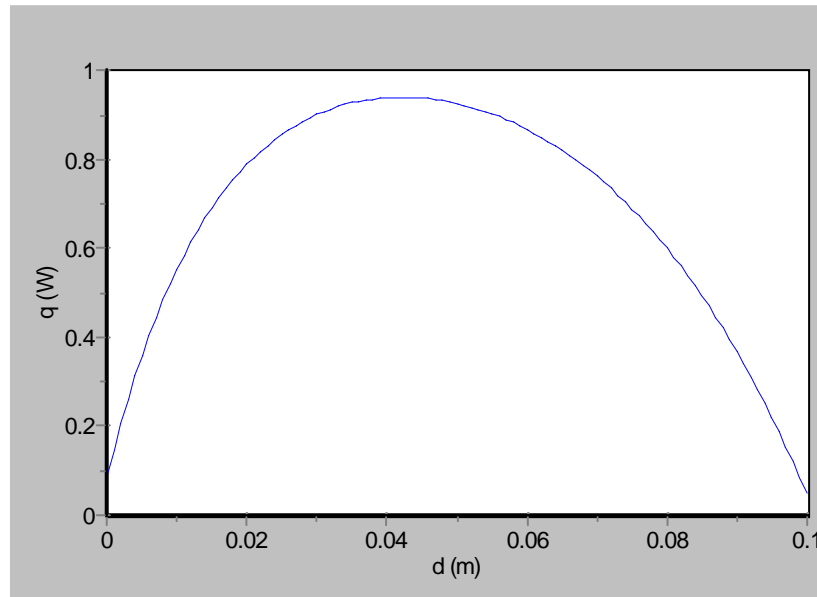

We see that there is an optimal insertion distance,  $d \cong 40$  mm. A longer fin length ( $\approx 60$  mm) is needed in fluid 2 to compensate for its smaller heat transfer coefficient.

COMMENTS: It is of interest to compare the heat transfer between the two fluids via the fin to the heat transfer through the wall. In Chapter 8 we will see how to calculate heat transfer coefficients for flow in a channel. Assuming that the channel widths are both approximately 50 mm, the heat transfer coefficients between the fluid and the wall are roughly  $40 \text{ W/m}^2\cdot\text{K}$  and  $10 \text{ W/m}^2\cdot\text{K}$  for the faster and slower streams, respectively. Then  $q'' = \frac{T_2 - T_1}{1/h_1 + 1/h_2} \cong 240 \text{ W/m}^2$ . A wall area of  $4 \times 10^{-3} \text{ m}^2$ , for example a 60 mm-square area, would be required to transfer the same amount of heat as the fin (in part a), 0.924 W.

## PROBLEM 7.68

**KNOWN:** Diameter and surface temperature of an uninsulated steam pipe. Velocity and temperature of air in cross flow.

**FIND:** (a) Heat loss per unit length, (b) Effect of insulation thickness on heat loss.

**SCHEMATIC:**

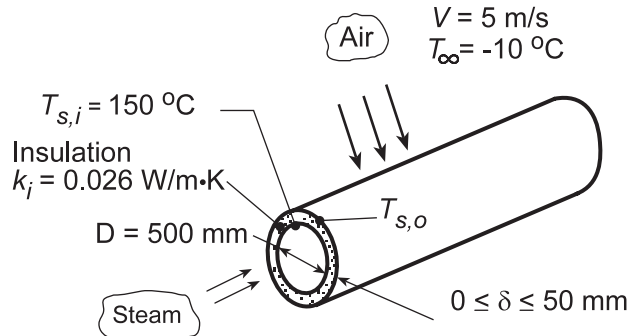

**ASSUMPTIONS:** (1) Steady-state conditions, (2) Uniform surface temperature, (3) Negligible radiation.

**PROPERTIES:** Table A.4, Air ( $T_f \approx 350$  K, 1 atm):  $\nu = 20.9 \times 10^{-6}$  m<sup>2</sup>/s,  $k = 0.030$  W/m·K,  $Pr = 0.70$ .

**ANALYSIS:** (a) Without the insulation, the heat loss per unit length is

$$q' = \bar{h} \pi D (T_{s,i} - T_{\infty})$$

where  $\bar{h}$  may be obtained from the Churchill-Bernstein relation. With

$$Re_D = \frac{VD}{\nu} = \frac{5 \text{ m/s} \times 0.5 \text{ m}}{20.9 \times 10^{-6} \text{ m}^2/\text{s}} = 1.196 \times 10^5$$

$$\overline{Nu}_D = 0.3 + \frac{0.62 Re_D^{1/2} Pr^{1/3}}{\left[1 + (0.4/Pr)^{2/3}\right]^{1/4}} \left[1 + \left(\frac{Re_D}{282,000}\right)^{5/8}\right]^{4/5} = 242$$

$$\bar{h} = \overline{Nu}_D \frac{k}{D} = 242 \frac{0.030 \text{ W/m} \cdot \text{K}}{0.5 \text{ m}} = 14.5 \text{ W/m}^2 \cdot \text{K}$$

The heat rate is then

$$q' = 14.5 \text{ W/m}^2 \cdot \text{K} \pi (0.5 \text{ m}) (150 - (-10))^\circ \text{C} = 3644 \text{ W/m}.$$

<

(b) With the insulation, the heat loss may be expressed as

$$q' = U_i \pi D (T_{s,i} - T_{\infty})$$

where, from Eq. 3.36,

$$U_i = \left[ \frac{(D/2)}{k_i} \ln \bar{r} + \frac{1}{\bar{r}h} \right]^{-1}$$

and  $\bar{r} \equiv (D/2 + \delta)/(D/2)$ . The outer diameter,  $D_o = D + 2\delta$ , as well as the film temperature,  $T_f = (T_{s,o} + T_{\infty})/2$ , must now be used to evaluate the convection coefficient, where

Continued...

### PROBLEM 7.68 (Cont.)

$$\frac{T_{s,i} - T_{s,o}}{T_{s,i} - T_{\infty}} = \frac{R'_{\text{cond}}}{R'_{\text{tot}}} = \frac{(\ln \bar{r})/k_i}{(\ln \bar{r})/k_i + 1/(D/2)\bar{h}}$$

Using the IHT *Correlations and Properties* Tool Pads to evaluate  $\bar{h}$ , the following results were obtained.

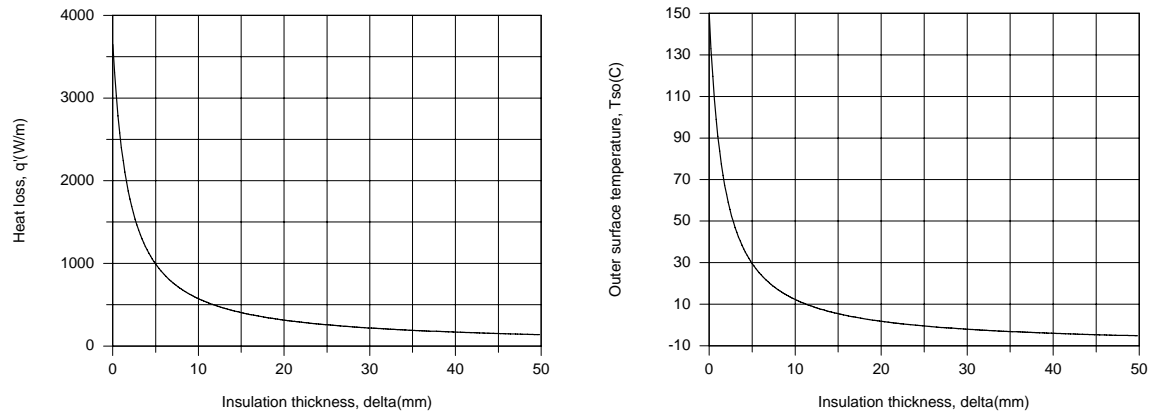

The insulation is extremely effective, with a thickness of only 10 mm yielding a 7-fold reduction in heat loss and decreasing the outer surface temperature from 150 to 10°C. For  $\delta = 50$  mm,  $U_i = 0.56 \text{ W/m}^2 \cdot \text{K}$ ,  $q' = 140 \text{ W/m}$  and  $T_{s,o} = -5.2^\circ\text{C}$ .

**COMMENTS:** The dominant contribution to the total thermal resistance is made by the insulation.

### PROBLEM 7.69

**KNOWN:** Dimensions and thermal conductivity of a thermocouple well. Temperatures at well tip and base. Air velocity.

**FIND:** Air temperature.

**SCHEMATIC:**

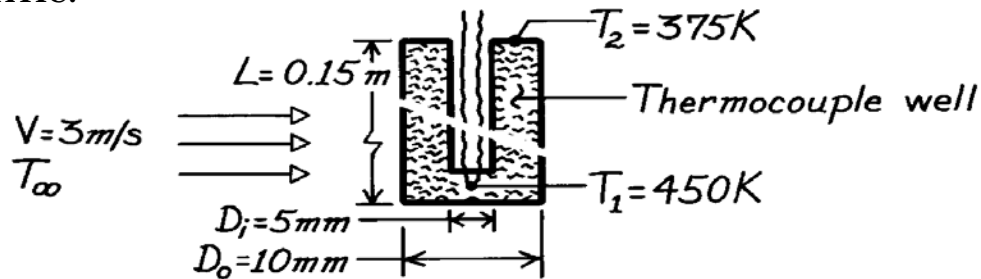

**ASSUMPTIONS:** (1) Steady-state conditions, (2) Constant properties, (3) One-dimensional conduction along well, (4) Uniform convection coefficient, (5) Negligible radiation.

**PROPERTIES:** Steel (given):  $k = 35 \text{ W/m}\cdot\text{K}$ ; Air (given):  $\rho = 0.774 \text{ kg/m}^3$ ,  $\mu = 251 \times 10^{-7} \text{ N}\cdot\text{s/m}^2$ ,  $k = 0.0373 \text{ W/m}\cdot\text{K}$ ,  $Pr = 0.686$ .

**ANALYSIS:** Applying Equation 3.75 at the well tip ( $x = L$ ), where  $T = T_1$ ,

$$\frac{T_1 - T_\infty}{T_2 - T_\infty} = \left[ \cosh mL + (\bar{h}/mk) \sinh mL \right]^{-1}$$

$$m = (\bar{h}P/kA_c)^{1/2} \quad P = \pi D_o = \pi(0.010 \text{ m}) = 0.0314 \text{ m}$$

$$A_c = (\pi/4)(D_o^2 - D_i^2) = (\pi/4)(0.010^2 - 0.005^2) \text{ m}^2 = 5.89 \times 10^{-5} \text{ m}^2.$$

$$\text{With } Re_D = \frac{\rho V D}{\mu} = \frac{0.774 \text{ kg/m}^3 (3 \text{ m/s}) 0.01 \text{ m}}{251 \times 10^{-7} \text{ N}\cdot\text{s/m}^2} = 925$$

$C = 0.51$ ,  $m = 0.5$ ,  $n = 0.37$  and the Zhukauskas correlation yields

$$\overline{Nu}_D = 0.51 Re_D^{0.5} Pr^{0.37} (Pr/Pr_s)^{1/4} \approx 0.51 (925)^{0.5} (0.686)^{0.37} \times 1 = 13.5$$

$$\bar{h} = \overline{Nu}_D \frac{k}{D_o} = 13.5 \frac{0.0373 \text{ W/m}\cdot\text{K}}{0.01 \text{ m}} = 50.4 \text{ W/m}^2 \cdot \text{K}.$$

Hence

$$m = \left[ \frac{(50.4 \text{ W/m}^2 \cdot \text{K}) 0.0314 \text{ m}}{(35 \text{ W/m}\cdot\text{K}) 5.89 \times 10^{-5} \text{ m}^2} \right]^{1/2} = 27.7 \text{ m}^{-1} \quad mL = (27.7 \text{ m}^{-1}) 0.15 \text{ m} = 4.15.$$

With

$$(\bar{h}/mk) = (50.4 \text{ W/m}^2 \cdot \text{K}) / (27.7 \text{ m}^{-1}) (35 \text{ W/m}\cdot\text{K}) = 0.0519$$

$$\text{find } \frac{T_1 - T_\infty}{T_2 - T_\infty} = [31.9 + (0.0519) 31.8]^{-1} = 0.0298 \quad T_\infty = 452.2 \text{ K.} \quad <$$

**COMMENTS:** Heat conduction along the wall to the base at 375 K is balanced by convection from the air.



## PROBLEM 7.70

**KNOWN:** Mercury-in-glass thermometer mounted on duct wall used to measure air temperature.

**FIND:** (a) Relationship for the immersion error,  $\Delta T_i = T(L) - T_\infty$  as a function of air velocity, thermometer diameter and length, (b) Length of insertion if  $\Delta T_i$  is not to exceed  $0.25^\circ\text{C}$  when the air velocity is 10 m/s, (c) For the length of part (b), calculate and plot  $\Delta T_i$  as a function of air velocity for 2 to 20 m/s, and (d) For a given insertion length, will  $\Delta T_i$  increase or decrease with thermometer diameter increase; is  $\Delta T_i$  more sensitive to diameter or velocity changes?

**SCHEMATIC:**

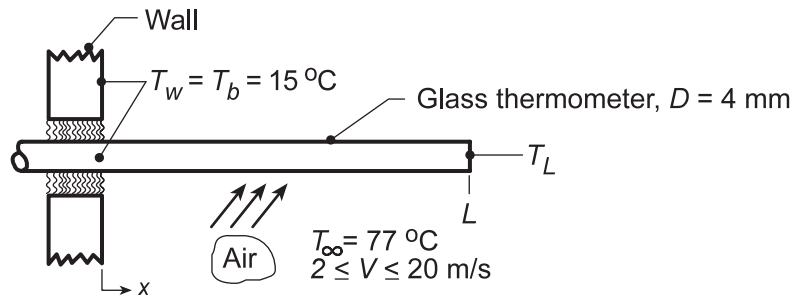

**ASSUMPTIONS:** (1) Steady-state conditions, (2) Thermometer approximates a one-dimensional (glass) fin with an *adiabatic* tip, (3) Convection coefficient is uniform over length of thermometer.

**PROPERTIES:** Table A.3, Glass (300 K):  $k_g = 1.4 \text{ W/m}\cdot\text{K}$ ; Table A.4, Air ( $T_f = (15 + 77)^\circ\text{C}/2 \approx 320 \text{ K}$ , 1 atm):  $k = 0.0278 \text{ W/m}\cdot\text{K}$ ,  $\nu = 17.90 \times 10^{-6} \text{ m}^2/\text{s}$ ,  $\text{Pr} = 0.704$ .

**ANALYSIS:** (a) From the analysis of a one-dimensional fin, see Table 3.4,

$$\frac{T_L - T_\infty}{T_b - T_\infty} = \frac{1}{\cosh(mL)} \quad m^2 = \frac{\bar{h}P}{k_g A_c} = \frac{4\bar{h}}{k_g D} \quad (1)$$

where  $P = \pi D$  and  $A_c = \pi D^2/4$ . Hence, the immersion error is

$$\Delta T_i = T(L) - T_\infty = (T_b - T_\infty) / \cosh(mL). \quad (2)$$

Using the Hilpert correlation for the circular cylinder in cross flow,

$$\bar{h} = \frac{k}{D} C \text{Re}_D^m \text{Pr}^{1/3} = \frac{k}{D} C \left( \frac{VD}{\nu} \right)^m \text{Pr}^{1/3} = \frac{k \text{Pr}^{1/3}}{\nu^m} \cdot C \cdot V^m \cdot D^{m-1} \quad (3)$$

$$\bar{h} = N \cdot V^m \cdot D^{m-1} \quad \text{where} \quad N = \frac{k \text{Pr}^{1/3}}{\nu^m} C \quad (4,5)$$

Substituting into Eq. (2), the immersion error is

$$\Delta T_i(V, D, L) = (T_b - T_\infty) / \cosh \left\{ \left[ \left( 4/k_g \right) N \cdot V^m \cdot D^{m-2} \right]^{1/2} L \right\} \quad (6) <$$

where  $k_g$  is the thermal conductivity of the glass thermometer.

(b) When the air velocity is 10 m/s, find

$$\text{Re}_D = \frac{VD}{\nu} = \frac{10 \text{ m/s} \times 0.004 \text{ m}}{17.9 \times 10^{-6} \text{ m}^2/\text{s}^2} = 2235$$

Continued...

### PROBLEM 7.70 (Cont.)

with  $C = 0.683$  and  $m = 0.466$  from Table 7.2 for the range  $40 < Re_D < 4000$ . From Eqs. (5) and (6),

$$N = \frac{0.0278 \text{ W/m} \cdot \text{K} (0.704)^{1/3}}{(17.9 \times 10^{-6} \text{ m/s}^2)^{0.466}} \times 0.683 = 2.753$$

$$\Delta T_i = (15 - 77) \text{ K} / \cosh \left\{ \left[ \frac{4}{1.4 \text{ W/m} \cdot \text{K}} \times 2.753 (10 \text{ m/s})^{0.466} (0.004 \text{ m})^{0.466-2} \right]^{1/2} L \right\}$$

and when  $\Delta T_i = -0.25^\circ\text{C}$ , find

$$L = 18.7 \text{ mm} \quad \leftarrow$$

(c) For the air velocity range 2 to 20 m/s, find  $447 \leq Re_D \leq 4470$  for which the previous values of  $C$  and  $m$  of the Hilpert correlation are appropriate. Hence, the immersion error for an insertion length of  $L = 18.7$  mm, part (b), find

$$\Delta T_i = (15 - 77) \text{ K} / \cosh \left\{ \left[ \frac{4}{1.4 \text{ W/m} \cdot \text{K}} \times 2.753 \times V^{0.466} (0.004 \text{ m}) - 1.534 \right]^{1/2} 0.0187 \right\}$$

$$\Delta T_i = -62^\circ\text{C} / \cosh \left( 3.629 V^{0.233} \right) \quad \leftarrow$$

where the units of  $V$  are [m/s]. Entering the above equation into the IHT Workspace the plot shown below was generated.

V(m/s)	$\Delta T_i$ ( $^\circ\text{C}$ )
2	-1.74
5	-0.63
10	-0.25
15	-0.14
20	-0.08

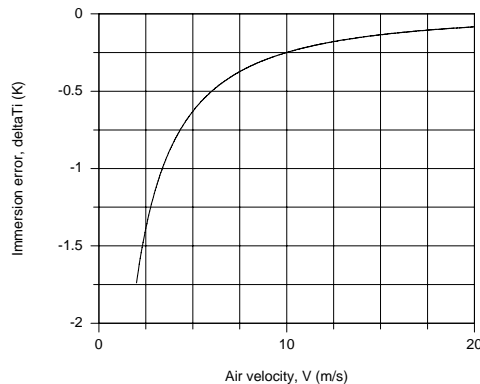

(d) For a given insertion length, the immersion error will *increase* if the diameter of the thermometer were *increased*. This follows from Eq. (6) written as

$$\Delta T_i \sim 1 / \cosh \left( A \cdot D^{(m-2)/2} \right) \quad (7)$$

where  $A$  is a constant depending on variables other than  $D$ . For a given insertion length and air velocity, from Eq. (6)

$$\Delta T_i \sim 1 / \cosh \left( B \cdot V^{m/2} \right) \quad (8)$$

where  $B$  is a constant. From Eq. (7) we see  $\Delta T_i$  relates to change in *diameter* as  $D^{-0.767}$  and to change in *velocity* as  $V^{0.233}$ . That is, to reduce the immersion error decrease  $D$  and increase  $V$  (both cause  $\bar{h}$  to increase!). Based upon the exponents of each parameter, however, diameter change is the more influential.

## PROBLEM 7.71

**KNOWN:** Long coated plastic, 20-mm diameter rod, initially at a uniform temperature of  $T_i = 25^\circ\text{C}$ , is suddenly exposed to the cross-flow of air at  $T_\infty = 350^\circ\text{C}$  and  $V = 50\text{ m/s}$ .

**FIND:** (a) Time for the surface of the rod to reach  $175^\circ\text{C}$ , the temperature above which the special coating cures, and (b) Compute and plot the time-to-reach  $175^\circ\text{C}$  as a function of air velocity for  $5 \leq V \leq 50\text{ m/s}$ .

**SCHEMATIC:**

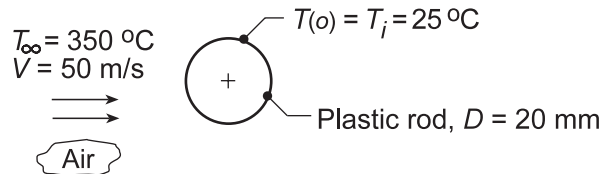

**ASSUMPTIONS:** (a) One-dimensional, transient conduction in the rod, (2) Constant properties, and (3) Evaluate thermophysical properties at  $T_f = [(T_s + T_i)/2 + T_\infty]/2 = [(175 + 25)/2 + 350]^\circ\text{C}/2 = 225^\circ\text{C} = 500\text{ K}$ .

**PROPERTIES:** Rod (Given):  $\rho = 2200\text{ kg/m}^3$ ,  $c = 800\text{ J/kg}\cdot\text{K}$ ,  $k = 1\text{ W/m}\cdot\text{K}$ ,  $\alpha = k/\rho c = 5.68 \times 10^{-7}\text{ m}^2/\text{s}$ ; Table A.4, Air ( $T_f \approx 500\text{ K}$ , 1 atm):  $\nu = 38.79 \times 10^{-6}\text{ m}^2/\text{s}$ ,  $k = 0.0407\text{ W/m}\cdot\text{K}$ ,  $\text{Pr} = 0.684$ .

**ANALYSIS:** (a) To determine whether the lumped capacitance method is valid, determine the Biot number

$$\text{Bi}_{lc} = \frac{\bar{h}(r_o/2)}{k} \quad (1)$$

The convection coefficient can be estimated using the Churchill-Bernstein correlation, Eq. 7.54,

$$\overline{\text{Nu}}_D = \frac{\bar{h}D}{k} = 0.3 + \frac{0.62 \text{Re}_D^{1/2} \text{Pr}^{1/3}}{\left[1 + (0.4/\text{Pr})^{2/3}\right]^{1/4}} \left[1 + \left(\frac{\text{Re}_D}{282,000}\right)^{5/8}\right]^{4/5}$$

$$\text{Re}_D = \frac{VD}{\nu} = 50\text{ m/s} \times 0.020\text{ m} / 38.79 \times 10^{-6}\text{ m}^2/\text{s} = 25,780$$

$$\bar{h} = \frac{0.0407\text{ W/m}\cdot\text{K}}{0.020\text{ m}} \left\{ 0.3 + \frac{0.62(25,780)^{1/2} (0.684)^{1/3}}{\left[1 + (0.4/0.684)^{2/3}\right]^{1/4}} \left[1 + \left(\frac{25,780}{282,000}\right)^{5/8}\right]^{4/5} \right\} = 184\text{ W/m}^2\cdot\text{K} \quad (2)$$

Substituting for  $\bar{h}$  from Eq. (2) into Eq. (1), find

$$\text{Bi}_{lc} = 184\text{ W/m}^2\cdot\text{K} (0.010\text{ m}/2) / 1\text{ W/m}\cdot\text{K} = 0.92 \quad \gg 0.1$$

Hence, the lumped capacitance method is inappropriate. Using the one-term series approximation, Eqs. 5.52 with Table 5.1,

$$\theta^* = C_1 \exp(-\zeta_1^2 \text{Fo}) J_0(\zeta_1 r^*) \quad r^* = r/r_o = 1$$

$$\theta^* = \frac{T(r_o, t) - T_\infty}{T_i - T_\infty} = \frac{(175 - 350)^\circ\text{C}}{(25 - 350)^\circ\text{C}} = 0.54$$

$$\text{Bi} = \bar{h}r_o/k = 1.84 \quad \zeta_1 = 1.546\text{ rad} \quad C_1 = 1.318$$

Continued...

**PROBLEM 7.71 (Cont.)**

$$0.54 = 1.318 \exp[-(1.546 \text{ rad})^2 \text{Fo}] J_0(1.546 \times 1)$$

Using Table B.4 to evaluate  $J_0(1.546) = 0.4859$ , find  $\text{Fo} = 0.0725$  where

$$\text{Fo} = \frac{\alpha t_o}{r_o^2} = \frac{5.68 \times 10^{-7} \text{ m}^2/\text{s} \times t_o}{(0.010 \text{ m})^2} = 5.68 \times 10^{-3} t_o \quad (6)$$

$$t_o = 12.8 \text{ s}$$

<

(b) Using the *IHT Model, Transient Conduction, Cylinder*, and the *Tool, Correlations, External Flow, Cylinder*, results for the time-to-reach a surface temperature of 175°C as a function of air velocity  $V$  are plotted below.

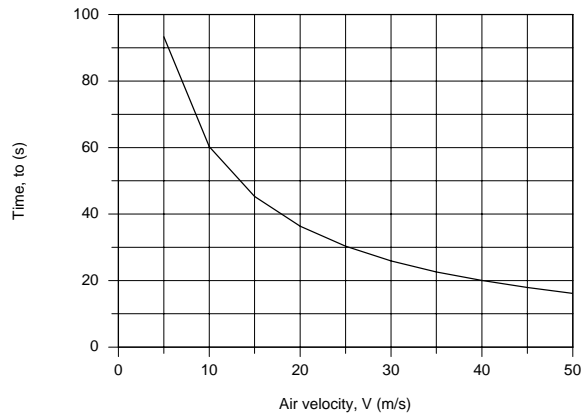

**COMMENTS:** (1) Using the *IHT Tool, Correlations, External Flow, Cylinder*, the effect of the film temperature  $T_f$  on the estimated convection coefficient with  $V = 50 \text{ m/s}$  can be readily evaluated.

$T_f$ (K)	460	500	623
$\bar{h}$ ( $\text{W}/\text{m}^2 \cdot \text{K}$ )	187	184	176

At early times,  $\bar{h} = 184 \text{ W}/\text{m}^2 \cdot \text{K}$  is a good estimate, while as the cylinder temperature approaches the airstream temperature, the effect starts to be noticeable (10% decrease).

(2) The IHT analysis performed for part (b) was developed in two parts. Using a known value for  $\bar{h}$ , the *Transient Conduction, Cylinder Model* was tested. Separately, the *Correlation Tools* was assembled and tested. Then, the two files were merged to give the workspace for determining the time-to-reach 175°C as a function of velocity  $V$ .

## PROBLEM 7.72

**KNOWN:** Velocity, diameter, initial temperature and properties of extruded wire. Temperature and velocity of air. Temperature of surroundings.

**FIND:** (a) Differential equation for temperature distribution  $T(x)$ , (b) Exact solution for negligible radiation and corresponding value of temperature at prescribed length of wire, (c) Effect of radiation on temperature of wire at prescribed length. Effect of wire velocity and emissivity on temperature distribution.

**SCHEMATIC:**

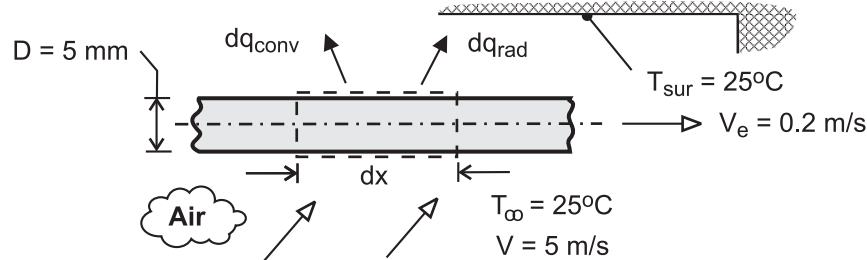

**ASSUMPTIONS:** (1) Negligible variation of wire temperature in radial direction, (2) Negligible effect of axial conduction along the wire, (3) Constant properties, (4) Radiation exchange between small surface and large enclosure, (5) Motion of wire has a negligible effect on the convection coefficient ( $V_e \ll V$ ).

**PROPERTIES:** Prescribed. Copper:  $\rho = 8900 \text{ kg/m}^3$ ,  $c_p = 400 \text{ J/kg} \cdot \text{K}$ ,  $\varepsilon = 0.55$ . Air:  
 $k = 0.037 \text{ W/m} \cdot \text{K}$ ,  $\nu = 3 \times 10^{-5} \text{ m}^2/\text{s}$ ,  $\text{Pr} = 0.69$ .

**ANALYSIS:** (a) Applying conservation of energy to a stationary control surface, through which the wire moves, steady-state conditions exist and  $\dot{E}_{\text{in}} - \dot{E}_{\text{out}} = 0$ . Hence, with *inflow* due to *advection* and *outflow* due to *advection*, *convection* and *radiation*,

$$\begin{aligned} \rho V_e A_c c_p T - \rho V_e A_c c_p (T + dT) - dq_{\text{conv}} - dq_{\text{rad}} &= 0 \\ -\rho V_e \left( \pi D^2 / 4 \right) c_p dT - \pi D dx \left[ \bar{h} (T - T_\infty) + \varepsilon \sigma (T^4 - T_{\text{sur}}^4) \right] &= 0 \\ \frac{dT}{dx} = -\frac{4}{\rho V_e D c_p} \left[ \bar{h} (T - T_\infty) + \varepsilon \sigma (T^4 - T_{\text{sur}}^4) \right] &\quad (1) \end{aligned}$$

Alternatively, if the control surface is fixed to the wire, conditions are transient and the energy balance is of the form,  $-\dot{E}_{\text{out}} = \dot{E}_{\text{st}}$ , or

$$\begin{aligned} -\pi D dx \left[ \bar{h} (T - T_\infty) + \varepsilon \sigma (T^4 - T_{\text{sur}}^4) \right] &= \rho \left( \frac{\pi D^2}{4} dx \right) c_p \frac{dT}{dt} \\ \frac{dT}{dt} = -\frac{4}{\rho D c_p} \left[ \bar{h} (T - T_\infty) + \varepsilon \sigma (T^4 - T_{\text{sur}}^4) \right] &\end{aligned}$$

Dividing the left- and right-hand sides of the equation by  $dx/dt$  and  $V_e = dx/dt$ , respectively, Eq. (1) is obtained.

(b) Neglecting radiation, separating variables and integrating, Eq. (1) becomes

$$\int_{T_1}^T \frac{dT}{T - T_\infty} = -\frac{4\bar{h}}{\rho V_e D c_p} \int_0^x dx$$

Continued ...

**PROBLEM 7.72 (Cont.)**

$$\ln\left(\frac{T - T_\infty}{T_i - T_\infty}\right) = -\frac{4\bar{h}x}{\rho V_e D c_p}$$

$$T = T_\infty + (T_i - T_\infty) \exp\left(-\frac{4\bar{h}x}{\rho V_e D c_p}\right) \quad (2) \quad <$$

With  $Re_D = VD/\nu = 5 \text{ m/s} \times 0.005 \text{ m} / 3 \times 10^{-5} \text{ m}^2/\text{s} = 833$ , the Churchill-Bernstein correlation yields

$$\overline{Nu}_D = 0.3 + \frac{0.62(833)^{1/2} (0.69)^{1/3}}{\left[1 + (0.4/0.69)^{2/3}\right]^{1/4}} \left[1 + \left(\frac{833}{282,000}\right)^{5/8}\right]^{4/5} = 14.4$$

$$\bar{h} = \frac{k}{D} \overline{Nu}_D = \frac{0.037 \text{ W/m}\cdot\text{K}}{0.005 \text{ m}} 14.4 = 107 \text{ W/m}^2 \cdot \text{K}$$

Hence, applying Eq. (2) at  $x = L$ ,

$$T_o = 25^\circ\text{C} + (575^\circ\text{C}) \exp\left(-\frac{4 \times 107 \text{ W/m}^2 \cdot \text{K} \times 5 \text{ m}}{8900 \text{ kg/m}^3 \times 0.2 \text{ m/s} \times 0.005 \text{ m} \times 400 \text{ J/kg}\cdot\text{K}}\right)$$

$$T_o = 340^\circ\text{C} \quad <$$

(c) Using the DER function of IHT, Eq. (1) may be numerically integrated from  $x = 0$  to  $x = L = 5.0 \text{ m}$  to obtain

$$T_o = 309^\circ\text{C} \quad <$$

Hence, radiation makes a discernable contribution to cooling of the wire. IHT was also used to obtain the following distributions.

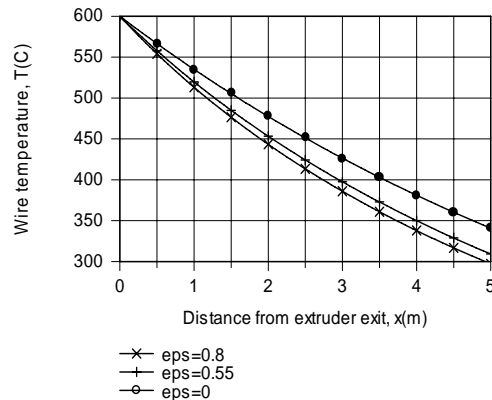
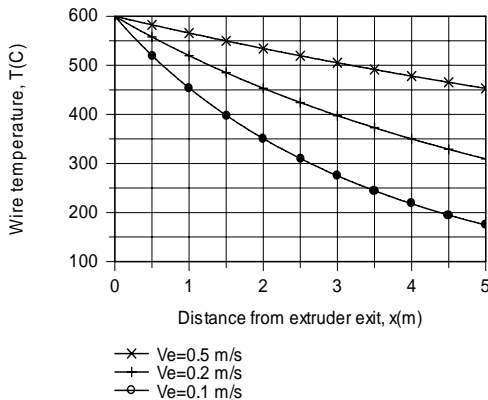

The speed with which the wire is drawn from the extruder has a significant influence on the temperature distribution. The temperature decay decreases with increasing  $V_e$  due to the increasing effect of advection on energy transfer in the  $x$  direction. The effect of the surface emissivity is less pronounced, although, as expected, the temperature decay becomes more pronounced with increasing  $\epsilon$ .

**COMMENTS:** (1) A critical parameter in wire extrusion processes is the *coiling temperature*, that is, the temperature at which the wire may be safely coiled for subsequent storage or shipment. The larger the production rate ( $V_e$ ), the longer the cooling distance needed to achieve a desired coiling temperature. (2) Cooling may be enhanced by increasing the cross-flow velocity, and the specific effect of  $V$  may also be explored.

### PROBLEM 7.73

**KNOWN:** Experimental apparatus comprised of a flat plate subjected to an airstream in parallel flow. Electrical patch heater on backside dissipates 15.5 W for all conditions. Pin fins fabricated from brass with prescribed diameter and length can be firmly attached to the plate. Fin tip and base temperatures observed for five different configurations (N, number of fins).

**FIND:** (a) The thermal resistance between the plate and airstream for the five configurations, (b) Model of the plate-fin system using appropriate convection correlations to predict the thermal resistances for the five configurations; compare predictions and observations; explain differences, and (b) Predict thermal resistances when the airstream velocity is doubled.

**SCHEMATIC:**

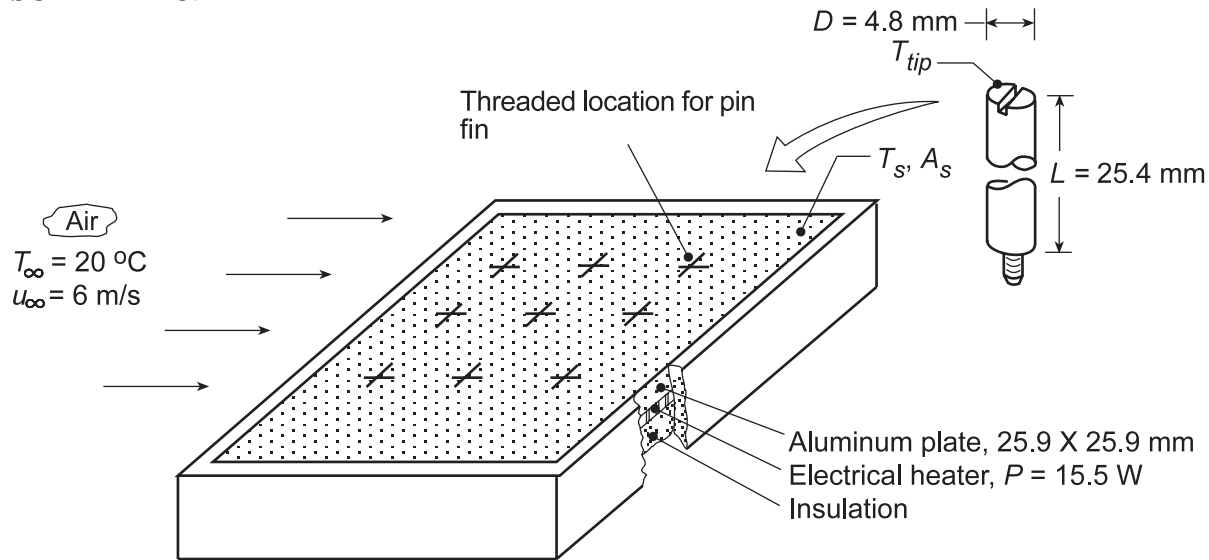

Experimental observations:	N	$T_{tip}$ (°C)	$T_s$ (°C)
	0	--	70.2
	1	40.6	67.4
	2	39.5	64.7
	5	36.4	57.4
	8	34.2	52.1

**ASSUMPTIONS:** (1) Steady-state conditions, (2) Negligible effect of flow interactions between pins, (3) Negligible radiation exchange with surroundings, (4) All heater power is transferred to airstream, and (5) Constant properties.

**PROPERTIES:** *Table A.4*, Air ( $T_f = 310$  K, 1 atm):  $k = 0.0270$  W/m·K,  $\nu = 1.69 \times 10^{-5}$  m<sup>2</sup>/s, Pr = 0.706; *Table A.1*, Brass ( $T = 300$  K):  $k = 110$  W/m·K.

**ANALYSIS:** (a) The thermal resistance between the plate and the airstream is defined as

$$R_{tot} = \frac{T_s - T_\infty}{q} \quad (1)$$

The heat rate is 15.5 W for all configurations and using  $T_s$  values from the above table with  $T_\infty = 20^\circ\text{C}$ , find

Continued...

**PROBLEM 7.73 (Cont.)**

N	0	1	2	5	8
R <sub>tot</sub> (K/W)	3.24	3.06	2.88	2.41	2.07

<

(b) The thermal resistance of the plate-fin system can be expressed as

$$R_{\text{tot}} = [1/R_{\text{base}} + N/R_{\text{fin}}]^{-1} \quad (2)$$

where the thermal resistance of the exposed portion of the base, A<sub>b</sub>, is

$$R_{\text{base}} = \frac{1}{\bar{h}_b A_b} \quad (3)$$

$$A_b = A_s - N A_c \quad (4)$$

where A<sub>c</sub> is the cross-sectional area of a fin and A<sub>s</sub> is the plate surface area. Approximating the airstream over the plate as parallel flow over a plate, use the *IHT Correlation Tool, External Flow, Flat Plate* assuming the flow is turbulent by the leading edge, to find

$$\bar{h}_b = 51 \text{ W/m}^2 \cdot \text{K}.$$

From the experimental observation with no fins (N = 0), the convection coefficient was measured as

$$\bar{h}_{b,\text{exp}} = \frac{q}{A_s (T_s - T_\infty)} = \frac{15.5 \text{ W}}{(0.0259 \text{ m})^2 (70.2 - 20)^\circ \text{C}} = 460 \text{ W/m}^2 \cdot \text{K}$$

Since the predicted coefficient is nearly an order of magnitude lower, we chose to use the experimental value in our subsequent analyses to predict overall system thermal resistance.

Approximating the airstream over a pin fin as cross-flow over a cylinder, use the *IHT Correlation Tool, External Flow, Cylinder* to find

$$\bar{h}_{\text{fin}} = 118 \text{ W/m}^2 \cdot \text{K}.$$

Using the *IHT Extended Surface Model for the Rectangular Pin Fin (Temperature Distribution and Heat Rate)* with a convection tip condition, the following fin thermal resistance was found as

$$R_{\text{fin}} = 25.4 \text{ K/W}$$

Using the foregoing values for R<sub>fin</sub> and  $\bar{h}_b$ , the thermal resistances of the plate-fin system are tabulated below.

N	0	1	2	4	8
R <sub>base</sub> (K/W)	3.241	3.331	3.426	3.746	4.133
R <sub>fin</sub> (K/W)	--	25.4	12.7	5.08	3.18
R <sub>tot</sub> (K/W)	3.24	2.95	2.70	2.16	1.80

<

By comparison with the experimental results of part (a), note that we assured agreement for the N = 0 condition by using the measured rather than estimated (correlation) convection coefficient. The predicted thermal resistances are systematically lower than the experimental values, with the worst case (N = 8) being 13% lower.

Continued...



### PROBLEM 7.73 (Cont.)

(c) The effect of doubling the velocity, from  $u_\infty = 6$  to  $12$  m/s, will cause the fin convection coefficient to increase from  $\bar{h}_{\text{fin}} = 118$  to  $169$  W/m<sup>2</sup>·K. For the base convection coefficient, we'll assume the flow is fully turbulent so that  $\bar{h} \sim (u_\infty)^{0.8}$  according to Eq. 7.38, hence

$$\bar{h}_b(12 \text{ m/s}) = \bar{h}_b(6 \text{ m/s}) \left( \frac{12}{6} \right)^{0.8} = 460 \text{ W/m}^2 \cdot \text{K} (2)^{0.8} = 800 \text{ W/m}^2 \cdot \text{K}$$

Using the same procedure as above, find

N	0	1	2	4	8
$R_{\text{base}}$ (K/W)	1.863	1.915	1.970	2.154	2.376
$R_{\text{fin}}$ (K/W)	--	18.96	9.480	4.740	2.370
$R_{\text{tot}}$ (K/W)	1.86	1.74	1.63	1.48	1.19

The effect of doubling the airstream velocity is to reduce the thermal resistance by approximately 35%.

### PROBLEM 7.74

**KNOWN:** Temperature and velocity of air flow over a sphere of prescribed surface temperature and diameter.

**FIND:** (a) Drag force, (b) Heat transfer rate with air velocity of 25 m/s; and (c) Compute and plot the heat rate as a function of air velocity for the range  $1 \leq V \leq 25$  m/s.

**SCHEMATIC:**

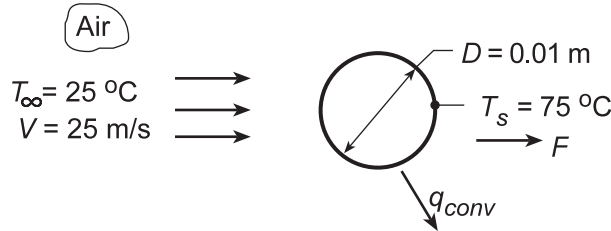

**ASSUMPTIONS:** (1) Steady-state conditions, (2) Uniform surface temperature, (3) Negligible radiation exchange with surroundings.

**PROPERTIES:** Table A.4, Air ( $T_\infty = 298$  K, 1 atm):  $\mu = 184 \times 10^{-7}$  N·s/m<sup>2</sup>;  $\nu = 15.71 \times 10^{-6}$  m<sup>2</sup>/s,  $k = 0.0261$  W/m·K,  $Pr = 0.71$ ; ( $T_s = 348$  K):  $\mu = 208 \times 10^{-7}$  N·s/m<sup>2</sup>; ( $T_f = 323$  K):  $\nu = 18.2 \times 10^{-6}$  m<sup>2</sup>/s,  $\rho = 1.085$  kg/m<sup>3</sup>.

**ANALYSIS:** (a) Working with properties evaluated at  $T_f$

$$Re_D = \frac{VD}{\nu} = \frac{25 \text{ m/s}(0.01 \text{ m})}{18.2 \times 10^{-6} \text{ m}^2/\text{s}} = 1.37 \times 10^4$$

and from Fig. 7.9, find  $C_D \approx 0.4$ . Hence

$$F_D = C_D \left( \pi D^2 / 4 \right) \left( \rho V^2 / 2 \right) = 0.4 (\pi / 4) (0.01 \text{ m})^2 1.085 \text{ kg/m}^3 (25 \text{ m/s})^2 / 2 = 0.011 \text{ N} <$$

(b) With

$$Re_D = \frac{VD}{\nu} = \frac{25 \text{ m/s}(0.01 \text{ m})}{15.71 \times 10^{-6} \text{ m}^2/\text{s}} = 1.59 \times 10^4$$

it follows from the Whitaker relation that

$$\begin{aligned} \overline{Nu}_D &= 2 + \left[ 0.4 Re_D^{1/2} + 0.06 Re_D^{2/3} \right] Pr^{0.4} \left( \frac{\mu}{\mu_s} \right)^{1/4} \\ \overline{Nu}_D &= 2 + \left[ 0.4 (1.59 \times 10^4)^{1/2} + 0.06 (1.59 \times 10^4)^{2/3} \right] (0.71)^{0.4} \left( \frac{184}{208} \right)^{1/4} = 76.7 \end{aligned}$$

Hence, the convection coefficient and convection heat rate are

$$\bar{h} = \overline{Nu}_D \frac{k}{D} = 76.7 \frac{0.0261 \text{ W/m} \cdot \text{K}}{0.01 \text{ m}} = 200 \text{ W/m}^2 \cdot \text{K}$$

$$q = \bar{h} \pi D^2 (T_s - T_\infty) = 200 \text{ W/m}^2 \cdot \text{K} \times \pi (0.01 \text{ m})^2 (75 - 25)^\circ \text{C} = 3.14 \text{ W} <$$

Continued...

## PROBLEM 7.74 (Cont.)

(c) Using the *IHT Correlation Tool, External Flow, Sphere*, the average coefficient and heat rate were calculated and are plotted below.

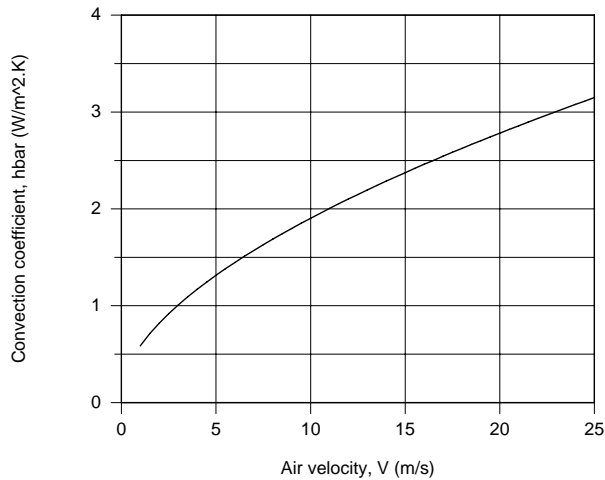

**COMMENTS:** (1) A copy of the IHT Workspace used to generate the above plot is shown below.

**// Correlation Tool - External Flow, Sphere:**

NuDbar = NuL\_bar\_EF\_SP(ReD,Pr,mu,mus) // Eq 7.56

NuDbar = hbar \* D / k

ReD = V \* D / nu

/\* Evaluate properties at Tinf and the surface temperature, Ts. \*/

/\* Correlation description: External flow (EF) over a sphere (SP), average coefficient,  $3.5 < \text{ReD} < 7.6 \times 10^4$ ,  $0.71 < \text{Pr} < 380$ ,  $1.0 < (\mu/\mu_s) < 3.2$ , Whitaker correlation, Eq 7.56. See Table 7.7. \*/

**// Properties Tool - Air:**

// Air property functions : From Table A.4

// Units: T(K); 1 atm pressure

mu = mu\_T("Air",Tinf) // Viscosity, N·s/m<sup>2</sup>

mus = mu\_T("Air",Ts) // Viscosity, N·s/m<sup>2</sup>

nu = nu\_T("Air",Tinf) // Kinematic viscosity, m<sup>2</sup>/s

k = k\_T("Air",Tinf) // Thermal conductivity, W/m·K

Pr = Pr\_T("Air",Tinf) // Prandtl number

**// Heat Rate Equation:**

q = hbar \* pi \* D<sup>2</sup> \* (Ts - Tinf)

**// Assigned Variables:**

D = 0.01 // Sphere diameter, m

Ts = 75 + 273 // Surface temperature, K

V = 25 // Airstream velocity, m/s

Tinf = 25 + 273 // Airstream temperature, K

## PROBLEM 7.75

**KNOWN:** Sphere with a diameter of 20 mm and a surface temperature of 60°C that is immersed in a fluid at a temperature of 30°C with a velocity of 2.5 m/s.

**FIND:** The drag force and the heat rate when the fluid is (a) water and (b) air at atmospheric pressure. Explain why the results for the two fluids are so different.

**SCHEMATIC:**

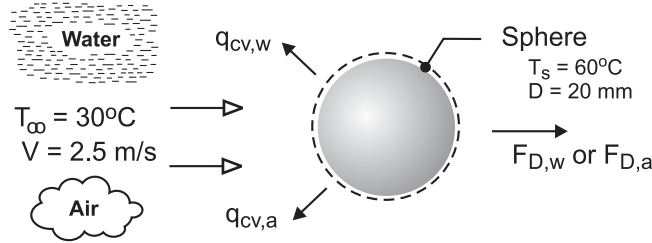

**ASSUMPTIONS:** (1) Flow over a smooth sphere, (2) Constant properties.

**PROPERTIES:** Table A-6, Water ( $T_\infty = 30^\circ\text{C} = 303\text{ K}$ ):  $\mu = 8.034 \times 10^{-4}\text{ N}\cdot\text{s}/\text{m}^2$ ,  $\nu = 8.068 \times 10^{-7}\text{ m}^2/\text{s}$ ,  $k = 0.6172\text{ W}/\text{m}\cdot\text{K}$ ,  $\text{Pr} = 5.45$ ; Water ( $T_s = 333\text{ K}$ ):  $\mu_s = 4.674 \times 10^{-4}\text{ N}\cdot\text{s}/\text{m}^2$ ; Table A-4, Air ( $T_\infty = 30^\circ\text{C} = 303\text{ K}$ , 1 atm):  $\mu = 1.86 \times 10^{-5}\text{ N}\cdot\text{s}/\text{m}^2$ ,  $\nu = 1.619 \times 10^{-5}\text{ m}^2/\text{s}$ ,  $k = 0.0265\text{ W}/\text{m}\cdot\text{K}$ ,  $\text{Pr} = 0.707$ ; Air ( $T_\infty = 333\text{ K}$ ):  $\mu_s = 2.002 \times 10^{-5}\text{ N}\cdot\text{s}/\text{m}^2$ .

**ANALYSIS:** The drag force,  $F_D$ , for the sphere is determined from the drag coefficient, Eq. 7.50,

$$C_D = \frac{F_D}{A_f \left( \rho V^2 / 2 \right)}$$

where  $A_f = \pi D^2 / 4$  is the frontal area.  $C_D$  is a function of the Reynolds number  $\text{Re}_D = VD / \nu$  as represented in Figure 7.9. For the convection rate equation,

$$q = \bar{h}_D A_s (T_s - T_\infty)$$

where  $A_s = \pi D^2$  is the surface area and the convection coefficient is estimated using the Whitaker correlation, Eq. 7.56,

$$\bar{\text{Nu}}_D = 2 + \left[ 0.4 \text{Re}_D^{1/2} + 0.06 \text{Re}_D^{2/3} \right] \text{Pr}^{0.4} (\mu / \mu_s)^{1/4}$$

where all properties except  $\mu_s$  are evaluated at  $T_\infty$ . For convenience we will evaluate properties required for the drag force at  $T_\infty$ . The results of the analyses for the two fluids are tabulated below.

Fluid	$\text{Re}_D$	$C_D$	$F_D$ (N)	$\bar{\text{Nu}}_D$	$\bar{h}_D$ ( $\text{W}/\text{m}^2 \cdot \text{K}$ )	$q$ (W)
water	$6.198 \times 10^4$	0.5	0.489	439	13,540	510
air	$3.088 \times 10^3$	0.4	$0.452 \times 10^{-3}$	31.9	42.3	1.59

The frontal and surface areas, respectively, are  $A_f = 3.142 \times 10^{-4}\text{ m}^2$  and  $A_s = 1.257 \times 10^{-3}\text{ m}^2$ .

**COMMENTS:** The Reynolds number is the ratio of inertia to viscous forces. We associate higher viscous shear and heat transfer with larger Reynolds numbers. The drag force also depends upon the fluid density, which further explains why  $F_D$  for water is much larger, by a factor of 1000, than for air.

$\text{Nu}_D$  is dependent upon  $\text{Re}_D^n$  where  $n$  is  $1/2$  to  $2/3$ , and represents the dimensionless temperature gradient at the surface. Since the thermal conductivity of water is nearly 20 times that of air, we expect a significant difference between  $\bar{h}_D$  and  $q$  for the two fluids.

## PROBLEM 7.76

**KNOWN:** Diameter, properties and initial temperature of niobium sphere. Velocity and temperature of nitrogen. Temperature of surroundings.

**FIND:** (a) Time for sphere to cool to prescribed temperature if radiation is neglected, (b) Cooling time if radiation is considered. Effect of flow velocity.

**SCHEMATIC:**

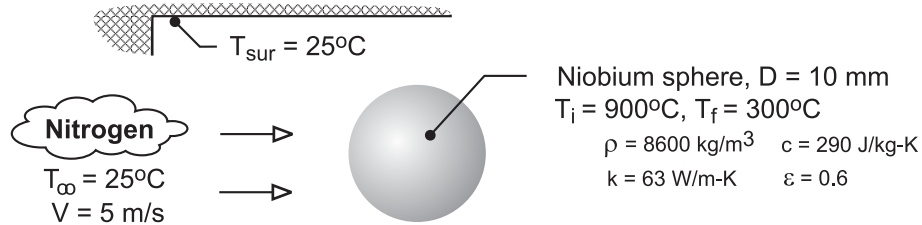

**ASSUMPTIONS:** (1) Lumped capacitance method is valid, (2) Constant properties, (3) Radiation exchange with large surroundings.

**PROPERTIES:** Table A-4, nitrogen ( $T_\infty = 298\text{K}$ ):  $\mu = 177 \times 10^{-7} \text{ N}\cdot\text{s}/\text{m}^2$ ,  $\nu = 15.7 \times 10^{-6} \text{ m}^2/\text{s}$ ,  $k = 0.0257 \text{ W}/\text{m}\cdot\text{K}$ ,  $\text{Pr} = 0.716$ . Table A-4, nitrogen ( $\bar{T}_s = 873\text{K}$ ):  $\mu_s = 368 \times 10^{-7} \text{ N}\cdot\text{s}/\text{m}^2$ .

**ANALYSIS:** (a) Neglecting radiation, the cooling time may be determined from Eq. (5.5),

$$t = \frac{\rho(\pi D^3/6)c}{\bar{h}\pi D^2} \ln \frac{\theta_i}{\theta} = \frac{\rho c D}{6\bar{h}} \ln \frac{T_i - T_\infty}{T_f - T_\infty}$$

The convection coefficient is obtained from the Whitaker correlation with  $\text{Re}_D = \text{VD}/\nu$   
 $= 5 \text{ m}/\text{s} \times 0.01 \text{ m} / 15.7 \times 10^{-6} \text{ m}^2/\text{s} = 3185$ . Hence,

$$\bar{\text{Nu}}_D = (\bar{h}D/k) = 2 + \left( 0.4 \text{Re}_D^{1/2} + 0.06 \text{Re}_D^{2/3} \right) \text{Pr}^{0.4} (\mu/\mu_s)^{1/4}$$

$$\bar{h} = \frac{0.0257 \text{ W}/\text{m}\cdot\text{K}}{0.01 \text{ m}} \left\{ 2 + \left[ 0.4(3185)^{1/2} + 0.06(3185)^{2/3} \right] (0.716)^{0.4} \left( \frac{177}{368} \right)^{0.25} \right\} = 71.8 \text{ W}/\text{m}^2\cdot\text{K}$$

$$t = \frac{8600 \text{ kg}/\text{m}^3 \times 290 \text{ J}/\text{kg}\cdot\text{K} \times 0.01 \text{ m}}{6 \times 71.8 \text{ W}/\text{m}^2\cdot\text{K}} \ln \frac{(900 - 25)}{(300 - 25)} = 67 \text{ s} \quad <$$

(b) If the effect of radiation is considered, the cooling time can be obtained by integrating Eq. (5.15).

With  $A_s/V = \pi D^2 / (\pi D^3/6) = 6/D$ , the appropriate form of the equation is

$$\frac{dT}{dt} = -\frac{6}{\rho c D} \left[ \bar{h}(T - T_\infty) + \varepsilon \sigma (T^4 - T_{\text{sur}}^4) \right]$$

Using the DER function of IHT to integrate this equation over the limits from  $T_i = 1173 \text{ K}$  to  $T_f = 573 \text{ K}$ , we obtain

$$t = 48 \text{ s} \quad <$$

Continued ...

### PROBLEM 7.76 (Cont.)

For  $V = 1.0$  and  $25.0$  m/s, the cooling times are  $t \approx 80$  and  $24$  s, respectively. Temperature histories for the three velocities are shown below.

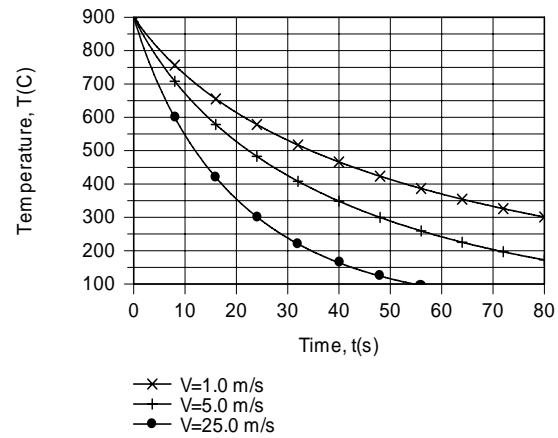

**COMMENTS:** The cooling time is significantly affected by the flow velocity.

## PROBLEM 7.77

**KNOWN:** An underwater instrument pod having a spherical shape with a diameter of 85 mm dissipating 300 W.

**FIND:** Estimate the surface temperature of the pod for these conditions: (a) when submersed in a bay where the water temperature is 15°C and the current is 1 m/s, and (b) after being hauled out of the water *without deactivating the power* and suspended in the ambient where the air temperature is 15°C and the wind speed is 3 m/s.

**SCHEMATIC:**

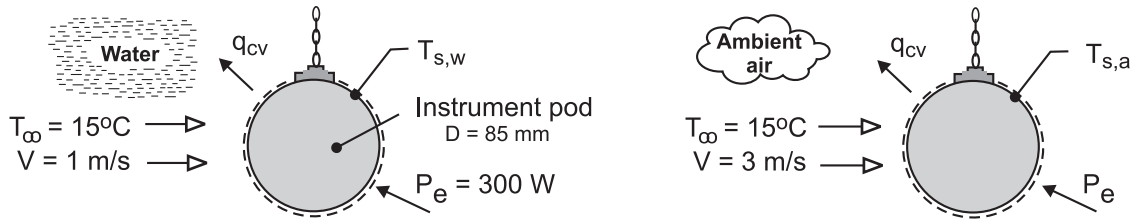

**ASSUMPTIONS:** (1) Steady-state conditions, (2) Flow over a smooth sphere, (3) Uniform surface temperatures, (4) Negligible radiation heat transfer for air (a) condition, and (5) Constant properties.

**PROPERTIES:** Table A-6, Water ( $T_\infty = 15^\circ\text{C} = 288\text{ K}$ ):  $\mu = 0.001053\text{ N}\cdot\text{s}/\text{m}^2$ ,  $\nu = 1.139 \times 10^{-6}\text{ m}^2/\text{s}$ ,  $k = 0.5948\text{ W}/\text{m}\cdot\text{K}$ ,  $\text{Pr} = 8.06$ ; Table A-4, Air ( $T_\infty = 288\text{ K}$ , 1 atm):  $\mu = 1.788 \times 10^{-5}\text{ N}\cdot\text{s}/\text{m}^2$ ,  $\nu = 1.482 \times 10^{-5}\text{ m}^2/\text{s}$ ,  $k = 0.02534\text{ W}/\text{m}\cdot\text{K}$ ,  $\text{Pr} = 0.710$ ; Air ( $T_s = 945\text{ K}$ ):  $\mu_s = 4.099 \times 10^{-5}\text{ N}\cdot\text{s}/\text{m}^2$ .

**ANALYSIS:** The energy balance for the submersed-in-water (w) and suspended-in-air (a) conditions are represented in the schematics above and have the form

$$\dot{E}_{\text{in}} - \dot{E}_{\text{out}} + \dot{E}_{\text{gen}} = -q_{\text{cv}} + P_e = 0 \quad (1)$$

$$-\bar{h}_D A_s (T_s - T_\infty) + P_e = 0$$

where  $A_s = \pi D^2$  and  $\bar{h}_D$  is estimated using the Whitaker correlation, Eq. 7.56,

$$\bar{\text{Nu}}_D = 2 + \left[ 0.4 \text{Re}_D^{1/2} + 0.06 \text{Re}_D^{2/3} \right] \text{Pr}^{0.4} (\mu/\mu_s)^{1/4} \quad (2)$$

where all properties except  $\mu_s$  are evaluated at  $T_\infty$ . The results are tabulated below.

Condition	$\text{Re}_D$	$\bar{\text{Nu}}_D$	$\bar{h}_D$ ( $\text{W}/\text{m}^2\cdot\text{K}$ )	$T_s$ ( $^\circ\text{C}$ )
(w) water	$7.465 \times 10^4$	499	3491	18.8
(a) air	$1.72 \times 10^4$	67.5	20.1	672

**COMMENTS:** (1) While submersed and dissipating 300 W, the pod is safely operating at a temperature slightly above that of the water. When hauled from the water and suspended in air, the pod temperature increases to a destruction temperature (672°C). The pod gets smoked!

(2) The assumption that  $\mu/\mu_s \approx 1$  is appropriate for the water (w) condition. For the air (a) condition,  $\mu/\mu_s = 0.436$  and the final term of the correlation is significant. Recognize that radiation exchange with the surroundings for the air condition should be considered for an improved estimate.

Continued ...

## PROBLEM 7.77 (Cont.)

(3) Why such a difference in  $T_s$  for the water (w) and air (a) conditions? From the results table note that the  $Re_D$ ,  $Nu_D$ , and  $\bar{h}_D$  are, respectively, 4x, 7x and 170x times larger for water compared to air. Water, because of its thermophysical properties which drive the magnitude of  $\bar{h}_D$ , is a much better coolant than air for similar flow conditions.

**/\* Comment:** Because  $T_s$  is much larger than  $T_{inf}$  for the in-air operation, the ratio of  $\mu / \mu_s$  exceeds the limits for the correlation. Hence, a warning message comes with the IHT solution. \*/

### **/\* Results - operation in air**

As	NuDbar	Pr	ReD	Tinf	Ts	Ts_C	hbar	k	mu
	mus	nu	D	Pelec	Tinf_C	V			
0.0227	67.5	0.7101	1.72E4	288	944.8	671.8	20.12	0.02534	1.786E-5
	4.099E-5	1.482E-5	0.085	300	15	3			

### **// Correlation, sphere**

$Nu_{Dbar} = Nu_{L\_bar\_EF\_SP}(Re_D, Pr, \mu, \mu_s)$  // Eq 7.56

$Nu_{Dbar} = \bar{h} * D / k$

$Re_D = V * D / \nu$

/\* All properties except  $\mu_s$  are evaluated at  $T_{inf}$ . \*/

/\* Correlation description: External flow (EF) over a sphere (SP), average coefficient,  $3.5 < Re_D < 7.6 \times 10^4$ ,  $0.71 < Pr < 380$ ,  $1.0 < (\mu / \mu_s) < 3.2$ , Whitaker correlation, Eq 7.56. See Table 7.9. \*/

### **// Energy balance**

$Pe_{lec} - \bar{h} * As * (T_s - T_{inf}) = 0$

$As = \pi * D^2$

### **// Input variables**

$D = 0.085$

$V = 1.0$  // Water current

$V = 3$  // Wind speed

$T_{inf\_C} = 15$

$Pe_{lec} = 300$

### **// Conversions**

$T_{inf} = T_{inf\_C} + 273$

$T_s = T_{s\_C} + 273$

### **// Air property functions : From Table A.4**

// Units: T(K); 1 atm pressure

$\mu = \mu_T(\text{"Air"}, T_{inf})$  // Viscosity, N·s/m<sup>2</sup>

$\mu_s = \mu_T(\text{"Air"}, T_s)$  // Viscosity, N·s/m<sup>2</sup>

//  $\mu_s = \mu$

$\nu = \nu_T(\text{"Air"}, T_{inf})$  // Kinematic viscosity, m<sup>2</sup>/s

$k = k_T(\text{"Air"}, T_{inf})$  // Thermal conductivity, W/m·K

$Pr = Pr_T(\text{"Air"}, T_{inf})$  // Prandtl number



## PROBLEM 7.78

**KNOWN:** Method to manufacture small diameter lead solder balls. Properties of  $D = 130 \mu\text{m}$  diameter particles ejected into nitrogen gas at  $V = 2 \text{ m/s}$ . Nitrogen temperature and pressure, initial particle temperature. Piezoelectric device oscillation frequency.

**FIND:** (a) Terminal velocity of the droplets and distance traveled when a droplet completely solidifies, (b) Separation distance between droplets and pot size needed to produce solder balls continuously for one week.

**SCHEMATIC:**

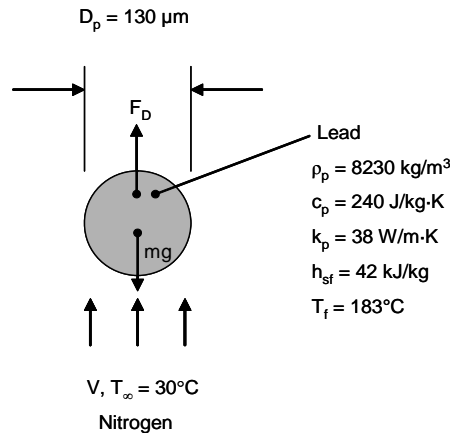

**ASSUMPTIONS:** (1) Negligible radiation heat transfer, (2) lumped capacitance thermal response.

**PROPERTIES:** Table A.4, Nitrogen: ( $T_f \approx (T_i + T_\infty)/2 = (225^\circ\text{C} + 30^\circ\text{C})/2 = 127.5^\circ\text{C} \approx 400 \text{ K}$ ):  $\rho = 0.8425 \text{ kg/m}^3$ ,  $\nu = 26.16 \times 10^{-6} \text{ m}^2/\text{s}$ . ( $\bar{T}_s = (225^\circ\text{C} + 183^\circ\text{C})/2 = 205^\circ\text{C} = 477 \text{ K}$ ):  $\mu_s = 248 \times 10^{-7} \text{ N}\cdot\text{s/m}^2$ . ( $T_\infty = 30^\circ\text{C} = 303 \text{ K}$ ):  $\rho = 1.1233 \text{ kg/m}^3$ ,  $\nu = 15.86 \times 10^{-6} \text{ m}^2/\text{s}$ ,  $k = 0.0259 \text{ W/m}\cdot\text{K}$ ,  $\mu = 178 \times 10^{-7} \text{ N}\cdot\text{s/m}^2$ ,  $\text{Pr} = 0.716$ .

**ANALYSIS:**

(a) A force balance on the particle yields

$$F_D = mg = \pi(D_p/2)^2 C_D \rho_f V^2/2 = \frac{4}{3} \pi (D_p/2)^3 \rho_p g$$

Which may be rearranged to yield

$$C_D = \frac{4}{3} D_p (\rho_p / \rho_f) g / V^2$$

$$C_D = \frac{4}{3} \times 130 \times 10^{-6} \text{ m} \times (8230/0.8425) \times 9.8 \text{ m/s}^2 / V^2$$

$$C_D = (16.59 \text{ m}^2 / \text{s}^2) / V^2 \tag{1}$$

and

Continued...

### PROBLEM 7.78 (Cont.)

$$\text{Re}_D = \frac{VD_p}{\nu} = V \times 130 \times 10^{-6} \text{ m} / 26.16 \times 10^{-6} \text{ m}^2/\text{s}$$

$$\text{Re}_D = (4.97 \text{ s/m}) \times V \quad (2)$$

Equations 1 and 2 may be solved for  $C_D$  and  $\text{Re}_D$  for any value of  $V$ . The resulting values of  $C_D$  and  $\text{Re}_D$  must be consistent with the results of Figure 7.9.

A trial-and-error solution yields  $V = 2.03 \text{ m/s}$ ,  $C_D = 4.03$ ,  $\text{Re}_D = 10.09$  from solution of Equations 1 and 2. From Figure 7.9, at  $\text{Re}_D = 10$ ,  $C_D = 4$ . Therefore  $V \approx 2 \text{ m/s}$ . <

We note that the terminal velocity is identical to the injection velocity. Hence, the particles travel at constant velocity. The particle cooling process occurs in two steps.

Step One: Particle cooling to  $T_f = 183^\circ\text{C}$ .

With nitrogen properties evaluated at  $T_\infty = 30^\circ\text{C}$ , the Reynolds number is

$$\text{Re}_D = \frac{2 \text{ m/s} \times 130 \times 10^{-6} \text{ m}}{15.86 \times 10^{-6} \text{ m}^2/\text{s}} = 16.39$$

The Whitaker correlation yields

$$\overline{\text{Nu}}_D = 2 + \left[ 0.4\sqrt{16.39} + 0.06 \times 16.39^{2/3} \right] \times 0.716^{0.4} \times \left( \frac{178}{248} \right)^{1/4} = 3.62$$

Therefore

$$\overline{h}_D = \overline{\text{Nu}}_D k / D_p = 3.62 \times 0.0259 \text{ W/m} \cdot \text{K} / 130 \times 10^{-6} \text{ m} = 721 \text{ W/m}^2 \cdot \text{K}$$

Using Equation 5.6 with  $A_s = 4\pi(D/2)^2 = 4 \times \pi \times (130 \times 10^{-6} \text{ m}/2)^2 = 53.1 \times 10^{-9} \text{ m}^2$ ,

$$\forall = (4/3) \pi (D/2)^3 = (4/3) \times \pi \times (130 \times 10^{-6} \text{ m}/2)^3 = 1.15 \times 10^{-12} \text{ m}^3,$$

$$\frac{T - T_\infty}{T_i - T_\infty} = \frac{183 - 30}{225 - 30} = 0.785 = \exp \left[ - \left( \frac{721 \text{ W/m}^2 \cdot \text{K} \times 53.1 \times 10^{-9} \text{ m}^2}{8230 \text{ kg/m}^3 \times 1.15 \times 10^{-12} \text{ m}^3 \times 240 \text{ J/kg} \cdot \text{K}} \right) \times t_1 \right]$$

from which

$$t_1 = 14.3 \times 10^{-3} \text{ s}$$

Step Two: Particle solidification at  $T_f = 183^\circ\text{C}$ .

An energy balance on the particle during solidification yields

$$\dot{E}_{\text{st}} + \dot{E}_{\text{out}} = 0$$

or

$$-\forall \rho_p h_{\text{sf}} - h A_s (T_f - T_\infty) t_2$$

or

$$t_2 = \frac{1.15 \times 10^{-12} \text{ m}^3 \times 8230 \text{ kg/m}^3 \times 42,000 \text{ J/kg}}{721 \text{ W/m}^2 \cdot \text{K} \times 53.1 \times 10^{-9} \text{ m}^2 \times (183 - 30)^\circ\text{C}} = 67.6 \times 10^{-3} \text{ s}$$

Therefore, the time to completely solidify is

Continued...

### PROBLEM 7.78 (Cont.)

$$T = t_1 + t_2 = 14.3 \times 10^{-3} \text{ s} + 67.6 \times 10^{-3} \text{ s} = 82 \times 10^{-3} \text{ s}$$

and the distance traveled is  $L = 2 \text{ m/s} \times 0.082 \text{ s} = 0.163 \text{ m}$

&lt;

(b) The distance that one particle travels is

$$L = (2 \text{ m/s}) / (1800 \text{ s}^{-1}) = 1.11 \text{ mm}$$

&lt;

The required pot size for one week of operation is

$$\forall_{\text{pot}} = 1.15 \times 10^{-12} \text{ m}^3/\text{particle} \times 1800 \text{ particles/s} \times 7 \text{ days} \times 24 \text{ h/day} \times 3600 \text{ s/h}$$

$$\forall_{\text{pot}} = 1.25 \times 10^{-3} \text{ m}^3$$

&lt;

**COMMENTS:** (1) The Biot number associated with the cooling of the particle is  $Bi = h(D_p/6)/k_p = 721 \text{ W/m}^2 \cdot \text{K} \times (130 \times 10^{-6} \text{ m/s}) / (38 \text{ W/m} \cdot \text{K}) = 0.0004 \ll 0.1$ . Therefore, the lumped capacitance assumption is valid. (2) The maximum possible radiation heat transfer coefficient is associated with the initial particle temperature and an emissivity of unity. Assuming a surroundings temperature of  $30^\circ\text{C} = 303 \text{ K}$ , we find a radiation heat transfer coefficient of  $h_r = 5.67 \times 10^{-8} \text{ W/m}^2 \cdot \text{K}^4 \times (498 + 303) \text{ K} \times (498^2 + 303^2) \text{ K}^2 = 15 \text{ W/m}^2 \cdot \text{K}$ . Therefore, radiation heat transfer is negligible. (3) The terminal velocity of the very small spherical particle is relatively low. This is because the surface area to weight ratio of a sphere is inversely proportional to the sphere diameter. As the sphere becomes small, drag forces become relatively large at relatively low velocities.

## PROBLEM 7.79

**KNOWN:** A spherical workpiece of pure copper with a diameter of 15 mm and emissivity of 0.5 is suspended in a large furnace with walls at a uniform temperature of 600°C. The air flow over the workpiece has a temperature of 900°C with a velocity of 7.5 m/s.

**FIND:** (a) The steady-state temperature of the workpiece; (b) Estimate the time required for the workpiece to reach within 5°C of the steady-state temperature if its initial, uniform temperature is 25°C; (c) Estimate the steady-state temperature of the workpiece if the air velocity is doubled with all other conditions remaining the same; also, determine the time required for the workpiece to reach within 5°C of this value. Plot on the same graph the workpiece temperature histories for the two air velocity conditions.

**SCHEMATIC:**

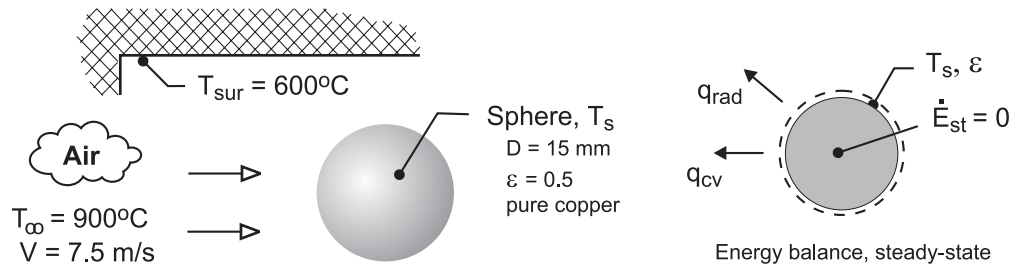

**ASSUMPTIONS:** (1) Flow over a smooth sphere, (2) Sphere behaves as spacewise isothermal object; lumped capacitance method is valid, (3) Sphere is small object in large, isothermal surroundings, and (4) Constant properties.

**PROPERTIES:** Table A-4, Air ( $T_\infty = 1173$  K, 1 atm):  $\mu = 4.665 \times 10^{-5}$  N·s/m<sup>2</sup>,  $\nu = 0.0001572$  m<sup>2</sup>/s,  $k = 0.075$  W/m·K,  $Pr = 0.728$ ; Air ( $T_s = 1010$  K, 1 atm):  $\mu_s = 4.268 \times 10^{-5}$  N·s/m<sup>2</sup>.

**ANALYSIS:** (a) The steady-state temperature is determined from the energy balance on the sphere as represented in the schematic above.

$$\begin{aligned} \dot{E}_{\text{in}} - \dot{E}_{\text{out}} + \dot{E}_{\text{gen}} &= 0 & -q_{\text{cv}} - q_{\text{rad}} + 0 &= 0 \\ -\bar{h}_D A_s (T_s - T_\infty) - \varepsilon A_s \sigma (T_s^4 - T_{\text{sur}}^4) &= 0 \end{aligned} \quad (1)$$

where  $A_s = \pi D^2/4$ . The convection coefficient can be estimated using the Whitaker correlation, Eq. 7.56, where all properties except  $\mu_s$  are evaluated at  $T_\infty$ . Assume  $T_s = 737^\circ\text{C} = 1010$  K to evaluate  $\mu_s$ .

$$\bar{Nu}_D = 2 + \left[ 0.4 Re_D^{1/2} + 0.06 Re_D^{2/3} \right] Pr^{0.4} (\mu/\mu_s)^{1/4} \quad (2)$$

See the table below for results of the correlation calculations. From the energy balance, canceling out  $A_s$ , with numerical values, find  $T_s$ .

$$-79.8 \text{ W/m}^2 \cdot \text{K} (T_s - 1173) \text{ K} - 0.5 \times 5.67 \times 10^{-8} \text{ W/m}^2 \cdot \text{K}^4 (T_s^4 - 873^4) \text{ K}^4 = 0$$

$$T_s = 1010 \text{ K} = 737^\circ\text{C}. \quad \leftarrow$$

(b) The time required for the sphere initially at  $T_i = 25^\circ\text{C}$  to reach within 5°C of the steady-state temperature can be determined from the energy balance for the transient condition.

Continued ...

**PROBLEM 7.79 (Cont.)**

$$\dot{E}_{\text{in}} - \dot{E}_{\text{out}} + \dot{E}_{\text{gen}} = \dot{E}_{\text{st}}$$

$$-\bar{h}_D A_s (T_s - T_\infty) - \varepsilon A_s \sigma (T_s^4 - T_{\text{sur}}^4) = \rho c \left( \pi D^3 / 6 \right) \frac{dT}{dt} \quad (3)$$

Recognize that  $\bar{h}_D$  is not constant, but depends upon  $T_s(t)$ . Using *IHT* to perform the integration, evaluate  $\bar{h}_D$ , and provide pure copper properties  $\rho$  and  $c$  as a function of  $T_s$ , the time  $t_o$  for  $T(t_o) = (737 - 5)^\circ\text{C} = 732^\circ\text{C}$  is

$$t_o = 274 \text{ s} \quad \leftarrow$$

See Comments 1 and 2 for details on the *IHT* calculation method.

(c) Use Eq. (1) and (2) to find the steady-state temperature when the air velocity is doubled,  $V = 2 \times 7.5 \text{ m/s} = 15 \text{ m/s}$ . The results are tabulated below along with those from part (a).

Part	V (m/s)	Re <sub>D</sub>	$\bar{\text{Nu}}_D$	$\bar{h}_D$ (W/m <sup>2</sup> ·K)	T <sub>s</sub> (°C)
a	7.5	715.6	15.96	79.8	737
b	15	1431	22.42	112.1	760

As expected, increasing the air velocity will cause the sphere temperature to increase toward  $T_\infty$ . Note that  $\bar{h}_D$  increases by a factor of 1.4 as the air velocity is doubled. From correlation Eq. (2) note that  $\bar{h}_D$  is approximately proportional to  $V^n$  where  $n$  is in the range 1/2 to 2/3. Using the *IHT* code for the lumped capacitance analysis, the time for  $T(t_o) = (760 - 5)^\circ\text{C} = 755^\circ\text{C}$  is

$$t_o = 230 \text{ s} \quad \leftarrow$$

The temperature histories for the two air velocity conditions are calculated using the foregoing transient analyses in the *IHT* workspace.

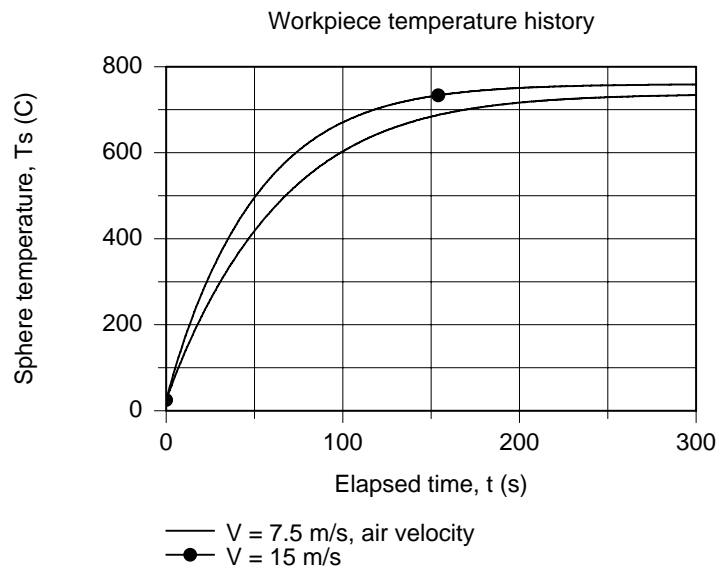

Continued ...

## PROBLEM 7.79 (Cont.)

**COMMENTS:** (1) The portion of the *IHT* code for performing the energy balance and evaluating the convection correlation function using the properties function follows.

```
// Convection correlation, sphere
NuDbar = NuL_bar_EF_SP(ReD,Pr,mu,mus) // Eq 7.56
NuDbar = hbar * D / k
ReD = V * D / nu
/* All properties except mus are evaluated at Tinf. */
/* Correlation description: External flow (EF) over a sphere (SP), average coefficient,
3.5<ReD<7.6x10^4, 0.71<Pr<380, 1.0<(mu/mus)<3.2, Whitaker correlation, Eq 7.56. See Table 7.9. */

// Energy balance, steady-state temperature
-hbar * As * (Ts - Tinf) - eps * sigma * (Ts^4 - Tsur^4) * As = 0
As = pi * D^2
sigma = 5.67e-8

// Air property functions : From Table A.4
// Units: T(K); 1 atm pressure
mu = mu_T("Air",Tinf) // Viscosity, N-s/m^2
mus = mu_T("Air",Ts) // Viscosity, N-s/m^2
nu = nu_T("Air",Tinf) // Kinematic viscosity, m^2/s
k = k_T("Air",Tinf) // Thermal conductivity, W/m-K
Pr = Pr_T("Air",Tinf) // Prandtl number

// Input variables
D = 0.015
eps = 0.5
V = 7.5
Tinf = 900 + 273
Tsur = 600 + 273
```

(2) Two modifications can be made to the code above to perform the lumped capacitance method for the transient analysis: (a) include the storage term in the energy balance and (b) provide the properties function for copper. The initial condition,  $T_i = 288$  K, is entered as the initial condition when the solver performs the integration.

```
// Energy balance, steady-state; equilibrium temperature
-hbar * As * (Ts - Tinf) - eps * sigma * (Ts^4 - Tfur^4) * As = M * ccu * der(Ts,t)
As = pi * D^2
sigma = 5.67e-8
M = rhocu * pi * D^3 / 6

// Copper (pure) property functions : From Table A.1
// Units: T(K)
rhocu = rho_300K("Copper") // Density, kg/m^3
kcu = k_T("Copper",Ts) // Thermal conductivity, W/m-K
ccu = cp_T("Copper",Ts) // Specific heat, J/kg-K
```

(3) Show that the lumped capacitance method is valid for this application.

### PROBLEM 7.80

**KNOWN:** Diameter and initial and final temperatures of copper spheres quenched in a water bath.

**FIND:** (a) Terminal velocity in the bath, (b) Tank height.

**SCHEMATIC:**

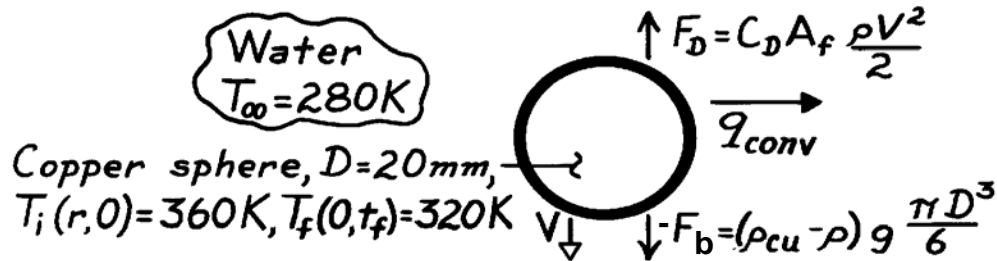

**ASSUMPTIONS:** (1) Sphere descends at terminal velocity, (2) Uniform, but time varying surface, temperature.

**PROPERTIES:** Table A-1, Copper (350K):  $\rho = 8933 \text{ kg/m}^3$ ,  $k = 398 \text{ W/m}\cdot\text{K}$ ,  $c_p = 387 \text{ J/kg}\cdot\text{K}$ ;  
 Table A-6, Water ( $T_\infty = 280 \text{ K}$ ):  $\rho = 1000 \text{ kg/m}^3$ ,  $\mu = 1422 \times 10^{-6} \text{ N}\cdot\text{s/m}^2$ ,  $k = 0.582 \text{ W/m}\cdot\text{K}$ ,  $\text{Pr} = 10.26$ ; ( $T_s \approx 340 \text{ K}$ ):  $\mu_s = 420 \times 10^{-5} \text{ N}\cdot\text{s/m}^2$ .

**ANALYSIS:** A force balance gives  $C_D \left( \frac{\pi D^2}{4} \right) \rho V^2 / 2 = (\rho_{cu} - \rho) g \pi D^3 / 6$ ,

$$C_D V^2 = \frac{4D}{3} \frac{\rho_{cu} - \rho}{\rho} g = \frac{4 \times 0.02 \text{ m}}{3} \cdot \frac{8933 - 1000}{1000} 9.8 \text{ m/s}^2 = 2.07 \text{ m}^2/\text{s}^2.$$

An iterative solution is needed, where  $C_D$  is obtained from Figure 7.9 with  $\text{Re}_D = VD/\nu = 0.02 \text{ m} / (1.42 \times 10^{-6} \text{ m}^2/\text{s}) = 14,085$ . Convergence is achieved with

$$V \approx 2.1 \text{ m/s} \quad <$$

for which  $\text{Re}_D = 29,580$  and  $C_D \approx 0.46$ . Using the Whitaker expression

$$\overline{\text{Nu}}_D = 2 + \left( 0.4 \times 29,850^{1/2} + 0.06 \times 29,850^{2/3} \right) (10.26)^{0.4} (1422/420)^{1/4} = 439$$

$$\bar{h} = \overline{\text{Nu}}_D k/D = 439 \times 0.582 \text{ W/m}\cdot\text{K} / 0.02 \text{ m} = 12,775 \text{ W/m}^2 \cdot \text{K}.$$

To determine applicability of lumped capacitance method, find  $\text{Bi} = \bar{h}(r_o/3)/k_{cu} = 12,775$

$\text{W/m}^2 \cdot \text{K} (0.01 \text{ m}/3) / 398 \text{ W/m}\cdot\text{K} = 0.11$ . Applicability is marginal. Using Eq. 5.53c,

$\theta_o^* = C_1 \exp(-\xi_1^2 \text{Fo})$  and from Table 5.1 at  $\text{Bi}_i = \bar{h} r_o/k = 0.32$ ,  $C_1 = 1.0937$ ,  $\xi_1 = 0.9472$ . Substituting into the preceding equation yields

$$0.5 = 1.0937 \exp(-0.9472^2 \text{Fo}) \text{ from which}$$

$$\text{Fo} = 0.87 = \alpha t_f / r_o^2$$

With  $\alpha_{cu} = k/\rho c_p = 398 \text{ W/m}\cdot\text{K} / (8933 \text{ kg/m}^3) (387 \text{ J/kg}\cdot\text{K}) = 1.15 \times 10^{-4} \text{ m}^2/\text{s}$ , find

$$t_f = 0.87 (0.01 \text{ m})^2 / 1.15 \times 10^{-4} \text{ m}^2/\text{s} = 0.76 \text{ s}.$$

Required tank height is

$$H = t_f \cdot V = 0.76 \text{ s} \times 2.1 \text{ m/s} = 1.6 \text{ m}. \quad <$$

**COMMENTS:** Note that the terminal velocity is not reached immediately. Reduced  $V$  implies reduced  $\bar{h}$  and increased  $t_f$ . The Fourier number,  $\text{Fo}$ , is greater than 0.2. Hence, use of Eq. 5.53c is justified.

### PROBLEM 7.81

**KNOWN:** Diameter and initial and final temperatures of copper spheres quenched in an oil bath.

**FIND:** (a) Terminal velocity in bath, (b) Bath height.

**SCHEMATIC:**

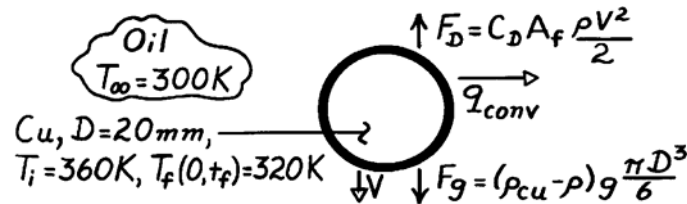

**ASSUMPTIONS:** (1) Sphere descends at terminal velocity, (2) Uniform, but time varying, surface temperature.

**PROPERTIES:** Table A-1, Copper (350K):  $\rho_{\text{Cu}} = 8933 \text{ kg/m}^3$ ,  $k = 398 \text{ W/m}\cdot\text{K}$ ,  $c_p = 387 \text{ J/kg}\cdot\text{K}$ ;  
Table A-5, Oil ( $T_\infty = 300\text{K}$ ):  $\rho = 884 \text{ kg/m}^3$ ,  $\mu = 0.486 \text{ N}\cdot\text{s/m}^2$ ,  $k = 0.145 \text{ W/m}\cdot\text{K}$ ,  $\text{Pr} = 6400$ ; ( $T_s \approx 340\text{K}$ ):  $\mu = 0.0531 \text{ N}\cdot\text{s/m}^2$ .

**ANALYSIS:** (a) Force balance gives  $C_D (\pi D^2 / 4) \rho V^2 / 2 = (\rho_{\text{Cu}} - \rho) g \pi D^3 / 6$ ,

$$C_D V^2 = \frac{4D}{3} \frac{\rho_{\text{Cu}} - \rho}{\rho} g = \frac{4 \times 0.02 \text{ m}}{3} \frac{8933 - 884}{884} 9.8 \frac{\text{m}}{\text{s}^2} = 2.38 \text{ m}^2 / \text{s}^2.$$

An iterative solution is needed, where  $C_D$  is obtained from Fig. 7.9 with

$$\text{Re}_D = \frac{VD}{\nu} = \frac{0.02 \text{ m} (V)}{(0.486/884) \text{ m}^2 / \text{s}} = 36.4 V (\text{m/s}).$$

Convergence is achieved for  $V \approx 1.1 \text{ m/s}$  <

for which  $\text{Re}_D = 40$  and  $C_D \approx 1.97$ . Using the Whitaker expression

$$\begin{aligned} \overline{\text{Nu}}_D &= 2 + \left( 0.4 \text{Re}_D^{1/2} + 0.06 \text{Re}_D^{2/3} \right) \text{Pr}^{0.4} (\mu / \mu_s)^{1/4} \\ \overline{\text{Nu}}_D &= 2 + \left( 0.4 \times 40^{1/2} + 0.06 \times 40^{2/3} \right) (6400)^{0.4} (0.486 / 0.0531)^{1/4} = 189.2 \\ \bar{h} &= \overline{\text{Nu}}_D k / D = 189.2 \times 0.145 / 0.02 = 1357 \text{ W/m}^2 \cdot \text{K}. \end{aligned}$$

To determine applicability of the lumped capacitance method, find  $\text{Bi} = \bar{h} (r_o / 3) / k_{\text{Cu}} =$

$1357 \text{ W/m}^2 \cdot \text{K} (0.01 \text{ m} / 3) / 398 \text{ W/m}\cdot\text{K} = 0.011$ . Hence lumped capacitance method can be used; from Eq. 5.5,

$$\begin{aligned} t_f &= \frac{(\rho c)_{\text{Cu}} \pi D^3 / 6}{\bar{h} \pi D^2} \ln \frac{T_i - T_\infty}{T_f - T_\infty} \\ t_f &= \frac{8933 \text{ kg/m}^3 \times 387 \text{ J/kg}\cdot\text{K} \times 0.02 \text{ m}}{1357 \text{ W/m}^2 \cdot \text{K}} \ln \frac{60}{20} = 9.33 \text{ s}. \end{aligned}$$

Required tank height is  $H = t_f \cdot V = 9.33 \text{ s} \times 1.1 \text{ m/s} = 10.3 \text{ m}$ . <

**COMMENTS:** (1) Whitaker correlation has been used well beyond its limits ( $\text{Pr} \gg 380$ ). Hence estimate of  $\bar{h}$  is uncertain. (2) Since terminal velocity is not reached immediately,

$\bar{h} < 1357 \text{ W/m}^2 \cdot \text{K}$  and  $t_f > 9.33 \text{ s}$ .



## PROBLEM 7.82

**KNOWN:** Velocity of plasma jet and initial particle velocity in a plasma spray coating process.  
Distance from particle injection to impact.

**FIND:** (a) Particle velocity and distance of travel as a function of time. Time-in-flight and particle impact velocity, (b) Convection heat transfer coefficient and time required to heat particle to melting point and to subsequently melt it.

**SCHEMATIC:**

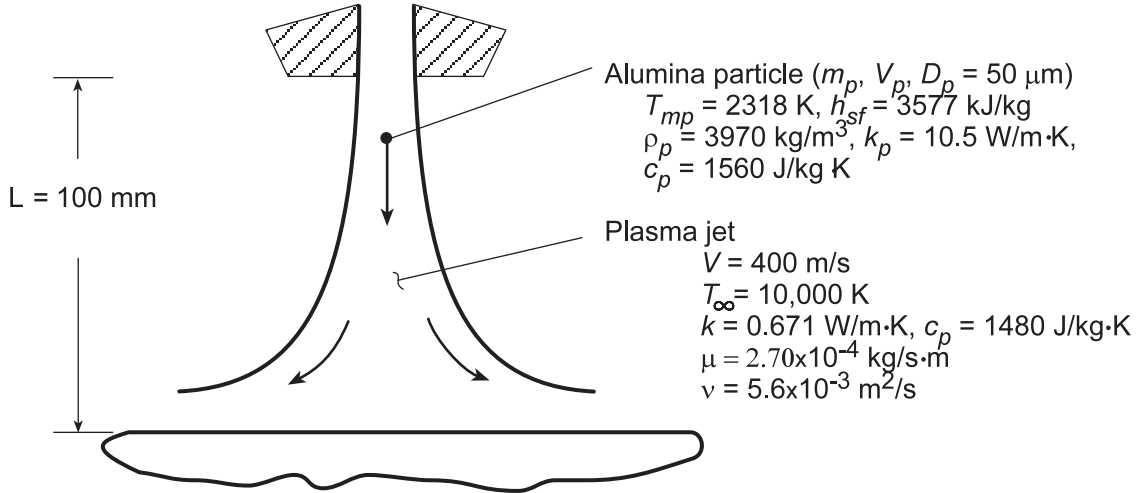

**ASSUMPTIONS:** (1) Applicability of Stokes' law, (2) Constant particle and plasma properties, (3) Negligible influence of viscosity ratio in Whitaker correlation, (4) Negligible radiation effects, (5) Validity of lumped capacitance approximation.

**ANALYSIS:** (a) From Eqs. 7.50 and 7.55,

$$C_D \equiv \frac{F_D}{A_f (\rho \bar{V}^2 / 2)} = \frac{24}{\text{Re}_D} = \frac{24}{\rho \bar{V} D_p / \mu}$$

where  $\bar{V} \equiv V - V_p$  is the relative velocity and  $A_f = \pi D_p^2 / 4$ . Hence, the drag force on the particle is

$$F_D = 3\pi\mu D_p \bar{V} = m_p (dV_p / dt) = -m_p (d\bar{V} / dt)$$

Separating variables and integrating from the nozzle exit, where  $V_p = 0$ ,  $\bar{V} = V$  and  $t = 0$ ,

$$\int_V \frac{d\bar{V}}{\bar{V}} = -\frac{3\pi\mu D_p}{m_p} \int_0^t dt$$

$$\ln \frac{\bar{V}}{V} = -\frac{3\pi\mu D_p t}{m_p}$$

$$\bar{V} = V \exp(-3\pi\mu D_p t / m_p) = V - V_p$$

Hence,

$$V_p(t) = V \left[ 1 - \exp(-3\pi\mu D_p t / m_p) \right]$$

With  $V_p = dx_p / dt$ , it follows that

$$\int_0^L dx_p = \int_0^{t_f} V \left[ 1 - \exp(-3\pi\mu D_p t / m_p) \right] dt$$

Continued... <

**PROBLEM 7.82 (Cont.)**

$$L = Vt_f - \frac{Vm_p}{3\pi\mu D_p} \left[ 1 - \exp(-3\pi\mu D_p t_f / m_p) \right] \quad <$$

Substituting the prescribed values of  $D_p$ ,  $L$ ,  $V$  and the material properties, the foregoing equations yield

$$V_p = 166.7 \text{ m/s} \quad t_f = 0.0011 \text{ s} \quad <$$

(b) Assuming an average value of  $\bar{V} = 315 \text{ m/s}$ , the Reynolds number is

$$Re_D = \frac{315 \text{ m/s} \times 50 \times 10^{-6} \text{ m}}{5.6 \times 10^{-3} \text{ m}^2/\text{s}} = 2.81$$

From the Whitaker correlation,

$$\bar{Nu}_D = 2 + \left( 0.4 Re_D^{1/2} + 0.06 Re_D^{2/3} \right) Pr^{0.4}$$

$$\bar{Nu}_D = 2 + \left( 0.4 \times 2.81^{1/2} + 0.06 \times 2.81^{2/3} \right) (0.60)^{0.4} = 2.64$$

$$\bar{h} = 2.64 k / D_p = 2.64 (0.671 \text{ W/m} \cdot \text{K}) / 50 \times 10^{-6} \text{ m} = 35,400 \text{ W/m}^2 \cdot \text{K} \quad <$$

The two-step melting process involves (i) the time  $t_1$  to heat the particle to its melting point and (ii) the time  $t_2$  required to achieve complete melting. Hence,  $t_m = t_1 + t_2$ , where from Eq. 5.5,

$$t_1 = \frac{\rho_p D_p c_p}{6\bar{h}} \ln \frac{T_i - T_\infty}{T_{mp} - T_\infty}$$

$$t_1 = \frac{3970 \text{ kg/m}^3 (50 \times 10^{-6} \text{ m}) 1560 \text{ J/kg} \cdot \text{K}}{6 (35,400 \text{ W/m}^2 \cdot \text{K})} \ln \frac{(300 - 10,000)}{(2318 - 10,000)} = 3.4 \times 10^{-4} \text{ s}$$

Performing an energy balance for the second step, we obtain

$$\int_{t_1}^{t_m} q_{conv} dt = \Delta E_{st} = \rho_p \forall h_{sf}$$

Hence,

$$t_2 = \frac{\rho_p D_p}{6\bar{h}} \frac{h_{sf}}{(T_\infty - T_{mp})} = \frac{3970 \text{ kg/m}^3 (50 \times 10^{-6} \text{ m})}{6 (35,400 \text{ W/m}^2 \cdot \text{K})} \times \frac{3.577 \times 10^6 \text{ J/kg}}{(10,000 - 2318) \text{ K}} = 4.4 \times 10^{-4} \text{ s}$$

Hence,

$$t_m = (3.4 \times 10^{-4} + 4.4 \times 10^{-4}) \text{ s} = 7.8 \times 10^{-4} \text{ s} \quad <$$

and the prescribed value of  $L$  is sufficient to insure complete melting before impact.

**COMMENTS:** (1) Since  $Bi = (\bar{h} r_p / 3) / k_p \approx 0.03$ , use of the lumped capacitance approach is appropriate.

(2) With  $Re_D = 2.81$ , conditions are slightly outside the ranges associated with Stokes' law.

### PROBLEM 7.83

**KNOWN:** Diameter, velocity, initial temperature and melting point of molten aluminum droplets. Temperature of helium atmosphere.

**FIND:** Maximum allowable separation between droplet injector and substrate.

**SCHEMATIC:**

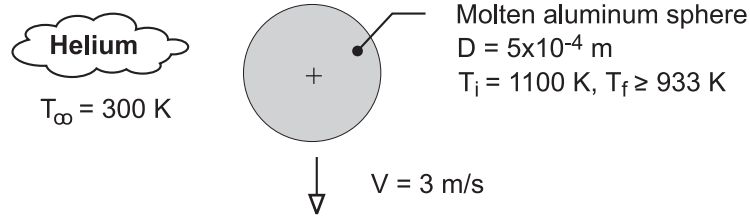

**ASSUMPTIONS:** (1) Lumped capacitance approximation is valid, (2) Constant properties, (3) Negligible radiation.

**PROPERTIES:** Table A-4, Helium ( $T_\infty = 300 \text{ K}$ ):  $\nu = 122 \times 10^{-6} \text{ m}^2/\text{s}$ ,  $\mu = 199 \times 10^{-7} \text{ N}\cdot\text{s}/\text{m}^2$ ,  $k = 0.152 \text{ W}/\text{m}\cdot\text{K}$ ,  $\text{Pr} = 0.68$ . Helium ( $T_s \approx 1000 \text{ K}$ ):  $\mu_s = 446 \times 10^{-7} \text{ N}\cdot\text{s}/\text{m}^2$ . Given, Aluminum:  $\rho = 2500 \text{ kg}/\text{m}^3$ ,  $c = 1200 \text{ J}/\text{kg}\cdot\text{K}$ ,  $k = 200 \text{ W}/\text{m}\cdot\text{K}$ .

**ANALYSIS:** With  $\text{Re}_D = VD/\nu = 3 \text{ m/s} (5 \times 10^{-4} \text{ m}) / 122 \times 10^{-6} \text{ m}^2/\text{s} = 12.3$ , the Whitaker correlation yields

$$\bar{h} = \frac{k}{D} \left[ 2 + \left( 0.4 \text{Re}_D^{1/2} + 0.06 \text{Re}_D^{2/3} \right) \text{Pr}^{0.4} \left( \mu / \mu_s \right)^{1/4} \right]$$

$$\bar{h} = \frac{0.152 \text{ W}/\text{m}\cdot\text{K}}{0.0005 \text{ m}} \left\{ 2 + \left[ 0.4 (12.3)^{1/2} + 0.06 (12.3)^{2/3} \right] (0.68)^{0.4} \left( \frac{199}{446} \right)^{1/4} \right\} = 975 \text{ W}/\text{m}^2 \cdot \text{K}$$

The *time-of-flight* for the droplet to cool from 1100K to 933K may be obtained from Eq. 5.5.

$$t = \frac{\rho \forall c}{\bar{h} A_s} \ln \frac{\theta_i}{\theta} = \frac{\rho c D}{6 \bar{h}} \ln \frac{T_i - T_\infty}{T_f - T_\infty}$$

$$t = \frac{(2500 \text{ kg}/\text{m}^3) 1200 \text{ J}/\text{kg}\cdot\text{K} (0.0005 \text{ m})}{6 \times 975 \text{ W}/\text{m}^2 \cdot \text{K}} \ln \left( \frac{800}{633} \right) = 0.06 \text{ s}$$

The maximum separation is therefore

$$L = V \times t = 3 \text{ m/s} \times 0.06 \text{ s} = 0.18 \text{ m} = 180 \text{ mm} \quad \leftarrow$$

**COMMENTS:** (1) With  $\text{Bi} = \bar{h} (D/6) / k = 4 \times 10^{-4}$ , the lumped capacitance approximation is excellent. (2) With the surroundings assumed to be at  $T_{\text{sur}} = T_\infty$  and a representative emissivity of  $\varepsilon = 0.1$  for molten aluminum,  $h_r \leq \varepsilon \sigma (T_i + T_\infty) (T_i^2 + T_\infty^2) \approx 10 \text{ W}/\text{m}^2 \cdot \text{K} \ll \bar{h} = 975 \text{ W}/\text{m}^2 \cdot \text{K}$ . Hence, radiation is, in fact, negligible. (3) Note that, for liquid metals especially, surfaces can quickly become oxidized. The oxidation layer restricts surface motion and the droplet can behave like a solid sphere. Thus we have used the Whitaker correlation in lieu of the Ranz-Marshall correlation.

## PROBLEM 7.84

**KNOWN:** Method to manufacture small diameter droplets. Properties of  $D = 75 \mu\text{m}$  diameter particles ejected into air. Air temperature and pressure, initial particle temperature. Desired temperature of drop upon impact of a substrate.

**FIND:** (a) Terminal velocity of the droplets, (b) Separation distance between droplet injection location and substrate so that the droplets impact the substrate at  $T_2 = 120^\circ\text{C}$ .

**SCHEMATIC:**

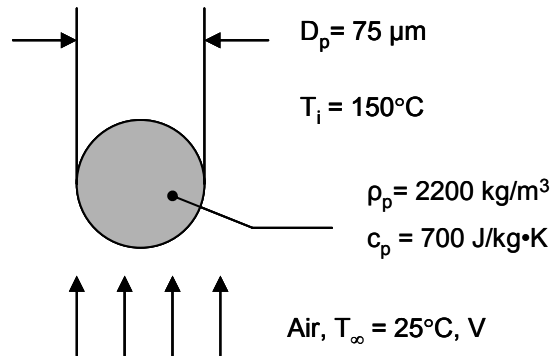

**ASSUMPTIONS:** (1) Negligible radiation heat transfer, (2) lumped capacitance thermal response, (3) Negligible microscale heat transfer effects.

**PROPERTIES:** Table A.4, air: ( $T_f \approx [(T_i + T_2)/2 + T_\infty]/2 = [(150^\circ\text{C} + 120^\circ\text{C})/2 + 25^\circ\text{C}]/2 = 80^\circ\text{C} \approx 353\text{ K}$ ):  $\rho = 0.9876\text{ kg/m}^3$ ,  $\nu = 21.25 \times 10^{-6}\text{ m}^2/\text{s}$ ,  $k = 0.03023\text{ W/m}\cdot\text{K}$ ,  $\text{Pr} = 0.6994$ . ( $\bar{T}_s = (150^\circ\text{C} + 120^\circ\text{C})/2 = 135^\circ\text{C} = 408\text{ K}$ ):  $\mu_s = 2.334 \times 10^{-5}\text{ N}\cdot\text{s/m}^2$ . ( $T_\infty = 25^\circ\text{C} = 298\text{ K}$ ):  $\nu = 15.71 \times 10^{-6}\text{ m}^2/\text{s}$ ,  $k = 0.02614\text{ W/m}\cdot\text{K}$ ,  $\mu = 1.836 \times 10^{-5}\text{ N}\cdot\text{s/m}^2$ ,  $\text{Pr} = 0.7075$ .

**ANALYSIS:**

(a) A force balance on the particle yields

$$\forall \rho_p g = C_D A_f (\rho V^2 / 2) \quad (1)$$

where  $\forall = \frac{4}{3} \pi (D_p/2)^3 = \frac{4}{3} \times \pi \times (75 \times 10^{-6}\text{ m}/2)^3 = 220.9 \times 10^{-15}\text{ m}^3$

$$A_f = \pi (D_p/2)^2 = \pi \times (75 \times 10^{-6}\text{ m}/2)^2 = 4.42 \times 10^{-9}\text{ m}^2$$

We also know

$$\text{Re}_D = \frac{V D_p}{\nu} = \frac{V \times 75 \times 10^{-6}\text{ m}}{21.25 \times 10^{-6}\text{ m}^2/\text{s}} = 3.53(\text{s/m}) \times V \quad (2)$$

The correct velocity will yield values of  $C_D$  and  $\text{Re}_D$  that are consistent with Figure 7.9. A trial-and-error solution yields (using properties at  $\bar{T}_f$ )

$$V \approx 0.30\text{ m/s}, \text{Re}_D = 1.06, C_D = 24.2 \quad (C_D \text{ from Figure 7.8} \approx 25) \quad <$$

(b) Using the Whitaker correlation with properties evaluated at  $T_\infty$ ,

$$\text{Re}_D = 0.3\text{ m/s} \times 75 \times 10^{-6}\text{ m} / 1.571 \times 10^{-5}\text{ m}^2/\text{s} = 1.43$$

Therefore,

Continued...

### PROBLEM 7.84 (Cont.)

$$\overline{\text{Nu}}_D = 2 + \left[ 0.4\sqrt{1.43} + 0.06 \times 1.43^{2/3} \right] \times 0.7075^{0.4} \times \left( \frac{1.836}{2.334} \right)^{1/4} = 2.45$$

$$\bar{h}_D = \overline{\text{Nu}}_D k / D_p = 2.45 \times 0.02614 \text{ W/m} \cdot \text{K} / 75 \times 10^{-6} \text{ m} = 854 \text{ W/m}^2 \cdot \text{K}$$

Using Equation 5.6 with  $A_s = 4 \times \pi \times (75 \times 10^{-6} \text{ m}/2)^2 = 17.7 \times 10^{-9} \text{ m}^2$ ,

$$\frac{T_2 - T_\infty}{T_1 - T_\infty} = \frac{120 - 25}{150 - 25} = 0.76 = \exp \left[ - \left( \frac{854 \text{ W/m}^2 \cdot \text{K} \times 17.7 \times 10^{-9} \text{ m}^2}{2200 \text{ kg/m}^3 \times 220.9 \times 10^{-15} \text{ m}^3 \times 700 \text{ J/kg} \cdot \text{K}} \right) \times t \right]$$

yielding  $t = 6.20 \times 10^{-3} \text{ s} = 6.2 \text{ ms}$ . The separation distance,  $L$ , is therefore

$$L = 0.30 \text{ m/s} \times 6.2 \times 10^{-3} \text{ s} = 1.86 \times 10^{-3} \text{ m} = 1.86 \text{ mm}$$

<

**COMMENTS:** (1) The maximum possible radiation heat transfer coefficient is associated with the initial particle temperature and an emissivity of unity. Assuming a surroundings temperature of  $25^\circ\text{C} = 298 \text{ K}$ , we find a radiation heat transfer coefficient of  $h_r = 5.67 \times 10^{-8} \text{ W/m}^2 \cdot \text{K}^4 \times (423 + 298) \text{ K} \times (423^2 + 298^2) \text{ K}^2 = 11 \text{ W/m}^2 \cdot \text{K}$ . Therefore, radiation heat transfer is negligible. (2) The terminal velocity of the very small spherical particle is very low. This is because the surface area to weight ratio of a sphere is inversely proportional to the sphere diameter. As the sphere becomes small, drag forces become relatively large at relatively low velocities. (3) The Whitaker correlation has been extrapolated outside of its recommended range of application. However, we know that the limiting value of the average Nusselt number is two. (4) The sphere is very small and the density of the sphere is relatively low. The lumped capacitance assumption is likely to be valid.

## PROBLEM 7.85

**KNOWN:** Velocity and temperature of combustion gases. Diameter and emissivity of thermocouple junction. Combustor temperature.

**FIND:** (a) Time to achieve 98% of maximum thermocouple temperature rise, (b) Steady-state thermocouple temperature, (c) Effect of gas velocity and thermocouple emissivity on measurement error.

**SCHEMATIC:**

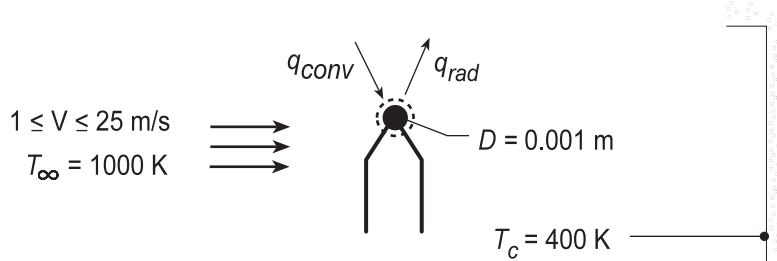

**ASSUMPTIONS:** (1) Validity of lumped capacitance analysis, (2) Constant properties, (3) Negligible conduction through lead wires, (4) Radiation exchange between small surface and a large enclosure (parts b and c).

**PROPERTIES:** Thermocouple (given):  $0.1 \leq \varepsilon \leq 1.0$ ,  $k = 100 \text{ W/m}\cdot\text{K}$ ,  $c = 385 \text{ J/kg}\cdot\text{K}$ ,  $\rho = 8920 \text{ kg/m}^3$ ; Gases (given):  $k = 0.05 \text{ W/m}\cdot\text{K}$ ,  $\nu = 50 \times 10^{-6} \text{ m}^2/\text{s}$ ,  $\text{Pr} = 0.69$ .

**ANALYSIS:** (a) If the lumped capacitance analysis may be used, it follows from Equation 5.5 that

$$t = \frac{\rho V c}{h A_s} \ln \frac{T_i - T_\infty}{T - T_\infty} = \frac{D \rho c}{6 h} \ln(50).$$

Neglecting the viscosity ratio correlation for variable property effects, use of  $V = 5 \text{ m/s}$  with the Whitaker correlation yields

$$\overline{\text{Nu}}_D = (\overline{h}D/k) = 2 + \left(0.4 \text{Re}_D^{1/2} + 0.06 \text{Re}_D^{2/3}\right) \text{Pr}^{0.4} \quad \text{Re}_D = \frac{VD}{\nu} = \frac{5 \text{ m/s}(0.001 \text{ m})}{50 \times 10^{-6} \text{ m}^2/\text{s}} = 100$$

$$\overline{h} = \frac{0.05 \text{ W/m}\cdot\text{K}}{0.001 \text{ m}} \left[ 2 + \left(0.4(100)^{1/2} + 0.06(100)^{2/3}\right) (0.69)^{0.4} \right] = 328 \text{ W/m}^2 \cdot \text{K}$$

Since  $\text{Bi} = \overline{h}(r_o/3)/k = 5.5 \times 10^{-4}$ , the lumped capacitance method may be used. Hence,

$$t = \frac{0.001 \text{ m} \left(8920 \text{ kg/m}^3\right) 385 \text{ J/kg}\cdot\text{K}}{6 \times 328 \text{ W/m}^2 \cdot \text{K}} \ln(50) = 6.83 \text{ s} \quad \leftarrow$$

(b) Performing an energy balance on the junction and evaluating radiation exchange,  $q_{\text{conv}} = q_{\text{rad}}$ . Hence, with  $\varepsilon = 0.5$ ,

$$\overline{h} A_s (T_\infty - T) = \varepsilon A_s \sigma (T^4 - T_c^4)$$

$$(1000 - T) \text{ K} = \frac{0.5 \times 5.67 \times 10^{-8} \text{ W/m}^2 \cdot \text{K}^4}{328 \text{ W/m}^2 \cdot \text{K}} \left[ T^4 - (400)^4 \right] \text{ K}^4.$$

$$T = 936 \text{ K} \quad \leftarrow$$

(c) Using the *IHT First Law Model for a Solid Sphere* with the appropriate *Correlation* for external flow from the Tool Pad, parametric calculations were performed to determine the effects of  $V$  and  $\varepsilon_g$ , and the following results were obtained.

Continued...

### PROBLEM 7.85 (Cont.)

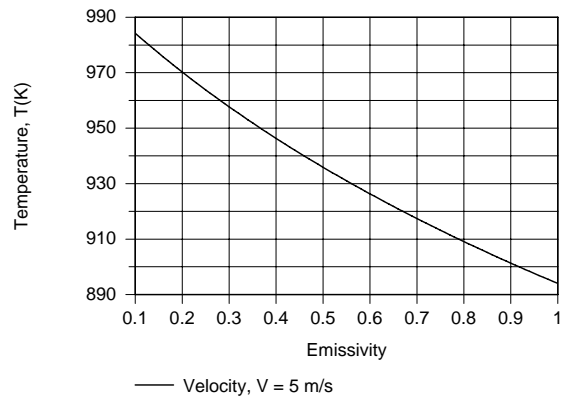
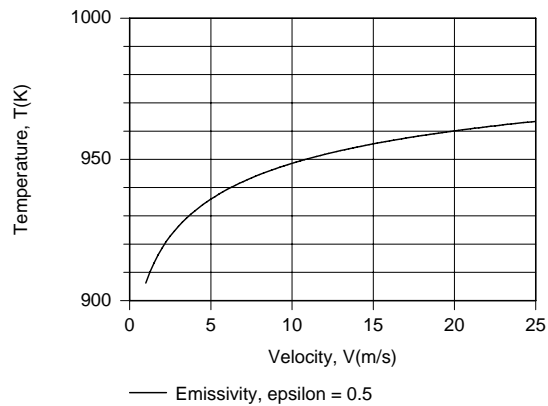

Since the temperature recorded by the thermocouple junction increases with increasing  $V$  and decreasing  $\epsilon$ , the measurement error,  $T_\infty - T$ , decreases with increasing  $V$  and decreasing  $\epsilon$ . The error is due to net radiative transfer from the junction (which depresses  $T$ ) and hence should decrease with decreasing  $\epsilon$ . For a prescribed heat loss, the temperature difference ( $T_\infty - T$ ) decreases with decreasing convection resistance, and hence with increasing  $h(V)$ .

**COMMENTS:** To infer the actual gas temperature (1000 K) from the measured result (936 K), correction would have to be made for radiation exchange with the cold surroundings.

## PROBLEM 7.86

**KNOWN:** Diameter, emissivity and temperature of a thermocouple junction exposed to hot gases flowing through a duct of prescribed surface temperature.

**FIND:** (a) Relative magnitudes of gas and thermocouple temperatures if the duct surface temperature is less than the gas temperature, (b) Gas temperature for prescribed conditions, (c) Effect of Velocity and emissivity on measurement error.

**SCHEMATIC:**

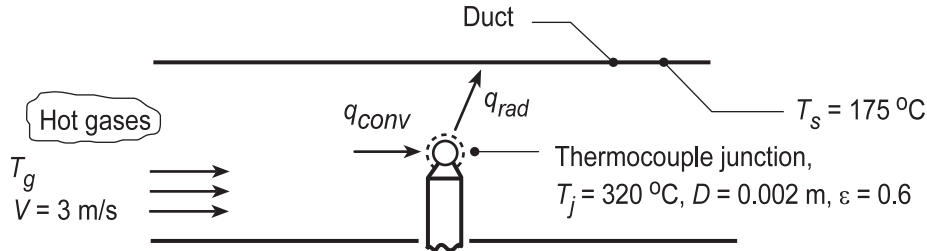

**ASSUMPTIONS:** (1) Steady-state conditions, (2) Junction is diffuse-gray, (3) Duct forms a large enclosure about the junction, (4) Negligible heat transfer by conduction through the thermocouple leads, (5) Gas properties are those of atmospheric air.

**PROPERTIES:** Table A-4, Air ( $T_g \approx 650$  K, 1 atm):  $\nu = 60.21 \times 10^{-6} \text{ m}^2/\text{s}$ ,  $k = 0.0497 \text{ W/m}\cdot\text{K}$ ,  $\text{Pr} = 0.690$ ,  $\mu = 322.5 \times 10^{-7} \text{ N}\cdot\text{s}/\text{m}^2$ ; Air ( $T_j = 593$  K, 1 atm):  $\mu = 304 \times 10^{-7} \text{ N}\cdot\text{s}/\text{m}^2$ .

**ANALYSIS:** (a) From an energy balance on the thermocouple junction,  $q_{\text{conv}} = q_{\text{rad}}$ . Hence,

$$\bar{h}A(T_g - T_j) = \varepsilon\sigma A(T_j^4 - T_s^4) \quad \text{or} \quad T_g - T_j = \frac{\varepsilon}{h}\sigma(T_j^4 - T_s^4).$$

If  $T_s < T_j$ , it follows that  $T_j < T_g$ . <

(b) Neglecting the variable property correction,  $(\mu/\mu_s)^{1/4} = (322.5/304)^{1/4} = 1.01 \approx 1.00$ , and using

$$\text{Re}_D = \frac{VD}{\nu} = \frac{3 \text{ m/s}(0.002 \text{ m})}{60.21 \times 10^{-6} \text{ m}^2/\text{s}} = 100$$

the Whitaker correlation for a sphere gives

$$\bar{h} = \frac{0.0497 \text{ W/m}\cdot\text{K}}{0.002 \text{ m}} \left\{ 2 + \left[ 0.4(100)^{1/2} + 0.06(100)^{2/3} \right] (0.69)^{0.4} \right\} = 163 \text{ W/m}^2 \cdot \text{K}.$$

Hence

$$(T_g - 593 \text{ K}) = \frac{0.6}{163 \text{ W/m}^2 \cdot \text{K}} 5.67 \times 10^{-8} \text{ W/m}^2 \cdot \text{K}^4 \left[ (593 \text{ K})^4 - (448 \text{ K})^4 \right] = 17 \text{ K}$$

$$T_g = 610 \text{ K} = 337^\circ\text{C}. \quad \text{<}$$

(c) With  $T_g$  fixed at 610 K, the IHT *First Law* Model was used with the *Correlations* and *Properties* Tool Pads to compute the measurement error as a function of  $V$  and  $\varepsilon$ .

Continued...



### PROBLEM 7.86 (Cont.)

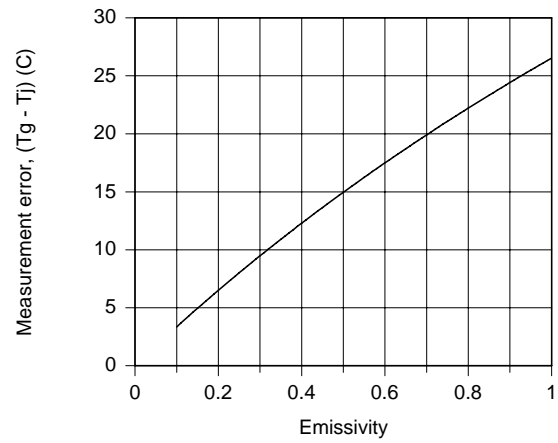
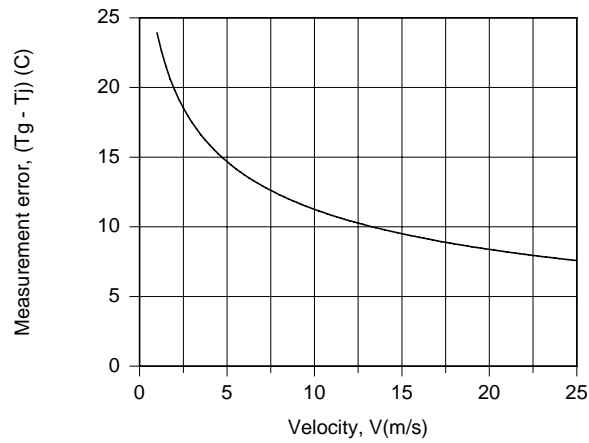

Since the convection resistance decreases with increasing  $V$ , the junction temperature will approach the gas temperature and the measurement error will decrease. Since the depression in the junction temperature is due to radiation losses from the junction to the duct wall, a reduction in  $\epsilon$  will reduce the measurement error.

**COMMENTS:** In part (b), calculations could be improved by evaluating properties at 610 K (instead of 650 K).

### PROBLEM 7.87

**KNOWN:** Diameter and emissivity of a thermocouple junction exposed to hot gases of prescribed velocity and temperature flowing through a duct of prescribed surface temperature.

**FIND:** (a) Thermocouple reading for gas at atmospheric pressure, (b) Thermocouple reading when gas pressure is doubled.

**SCHEMATIC:**

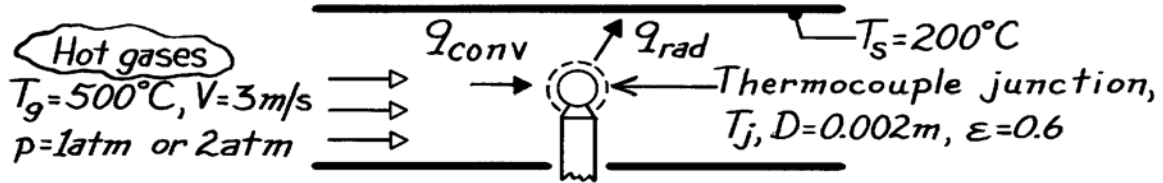

**ASSUMPTIONS:** (1) Steady-state conditions, (2) Junction is diffuse-gray, (3) Duct forms a large enclosure about junction, (4) Negligible heat loss by conduction through thermocouple leads, (5) Gas properties are those of air, (6) Perfect gas behavior.

**PROPERTIES:** Table A-4, Air ( $T_g = 773\text{ K}$ , 1 atm):  $\nu = 80.5 \times 10^{-6}\text{ m}^2/\text{s}$ ,  $k = 0.0561\text{ W/m}\cdot\text{K}$ ,  $\text{Pr} = 0.705$ .

**ANALYSIS:** (a) Performing an energy balance on the junction

$$q_{\text{conv}} = q_{\text{rad}}$$

$(g \rightarrow j) \quad (j \rightarrow s)$

$$\bar{h}A(T_g - T_j) = \epsilon\sigma A(T_j^4 - T_s^4).$$

Neglecting the variable property correction,  $(\mu/\mu_s)^{1/4}$ , and using

$$\text{Re}_D = \frac{VD}{\nu} = \frac{3\text{ m/s} \times 0.002\text{ m}}{80.5 \times 10^{-6}\text{ m}^2/\text{s}} = 74.5$$

the Whitaker correlation for a sphere gives,

$$\bar{h} = \frac{0.0561\text{ W/m}\cdot\text{K}}{0.002\text{ m}} \left\{ 2 + \left[ 0.4(74.5)^{1/2} + 0.06(74.5)^{2/3} \right] (0.705)^{0.4} \right\} = 166\text{ W/m}^2\cdot\text{K}.$$

$$166(773 - T_j) = 0.6 \times 5.67 \times 10^{-8} \left[ T_j^4 - (473)^4 \right]$$

and from a trial-and-error solution,

$$T_j \approx 726\text{ K.} \quad <$$

(b) Assuming all properties other than  $\nu$  to remain constant with a change in pressure,  $\uparrow p$  by 2 will  $\downarrow \nu$  by 2 and hence  $\uparrow \text{Re}_D$  by 2, giving  $\text{Re}_D = 149$ . Hence

$$\bar{h} = \frac{0.0561}{0.002} \left\{ 2 + \left[ 0.4(149)^{1/2} + 0.06(149)^{2/3} \right] (0.705)^{0.4} \right\} = 216\text{ W/m}^2\cdot\text{K}.$$

$$216(773 - T_j) = 0.6 \times 5.67 \times 10^{-8} \left[ T_j^4 - (473)^4 \right]$$

and from a trial-and-error solution

$$T_j \approx 735\text{ K.} \quad <$$

**COMMENTS:** The thermocouple error will  $\downarrow$  with  $\uparrow h$ , which  $\uparrow$  with  $\uparrow p$ .

## PROBLEM 7.88

**KNOWN:** Initial temperature, dimensions and properties of chip and solder connectors. Velocity, temperature and properties of liquid.

**FIND:** (a) Ratio of time constants (chip-to-solder), (b) Chip-to-solder temperature difference after 0.25s of heating.

**SCHEMATIC:**

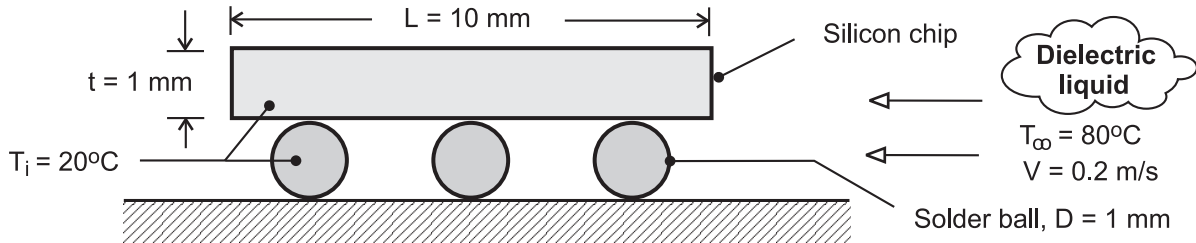

**ASSUMPTIONS:** (1) Solder balls and chips are spatially isothermal, (2) Negligible heat transfer from sides of chip, (3) Top and bottom surfaces of chip act as flat plates in turbulent parallel flow, (4) Heat transfer from solder balls may be approximated as that from an isolated sphere, (5) Constant properties.

**PROPERTIES:** Given. Dielectric liquid:  $k = 0.064 \text{ W/m}\cdot\text{K}$ ,  $\nu = 10^{-6} \text{ m}^2/\text{s}$ ,  $\text{Pr} = 25$ ; Silicon chip:  $k = 150 \text{ W/m}\cdot\text{K}$ ,  $\rho = 2300 \text{ kg/m}^3$ ,  $c_p = 700 \text{ J/kg}\cdot\text{K}$ ; Solder ball:  $k = 40 \text{ W/m}\cdot\text{K}$ ,  $\rho = 10,000 \text{ kg/m}^3$ ,  $c_p = 150 \text{ J/kg}\cdot\text{K}$ .

**ANALYSIS:** (a) From Eq. 5.7, the thermal time constant is  $\tau_t = (\rho \nabla c / \bar{h} A_s)$ . Hence,

$$\frac{\tau_{t,\text{ch}}}{\tau_{t,\text{sld}}} = \frac{(\rho c)_{\text{ch}} (L^2 t)}{2 \bar{h}_{\text{ch}} L^2} \frac{\bar{h}_{\text{sld}} (\pi D^2)}{(\rho c)_{\text{sld}} (\pi D^3 / 6)} = 3 \frac{t}{D} \frac{(\rho c)_{\text{ch}} \bar{h}_{\text{sld}}}{(\rho c)_{\text{sld}} \bar{h}_{\text{ch}}}$$

The convection coefficient for the chip may be obtained from Eq. 7.38 with  $A = 0$ , with  $\text{Re}_L = VL/\nu = 0.2 \text{ m/s} \times 0.01 \text{ m} / 10^{-6} \text{ m}^2/\text{s} = 2000$ .

$$\bar{h}_{\text{ch}} = \frac{0.064 \text{ W/m}\cdot\text{K}}{0.01 \text{ m}} (0.037) (2000)^{4/5} (25)^{1/3} = 302 \text{ W/m}^2\cdot\text{K}$$

The convection coefficient for the solder may be obtained from Eq. 7.56, with  $\text{Re}_D = VD/\nu = 0.2 \text{ m/s} \times 0.001 \text{ m} / 10^{-6} \text{ m}^2/\text{s} = 200$ . Neglecting the effect of the viscosity ratio,

$$\bar{h}_{\text{sld}} = \frac{0.064 \text{ W/m}\cdot\text{K}}{0.001 \text{ m}} \left\{ 2 + \left[ 0.4 (200)^{1/2} + 0.06 (200)^{2/3} \right] (25)^{0.4} \right\} = 1916 \text{ W/m}^2\cdot\text{K}$$

Hence, 
$$\frac{\tau_{t,\text{ch}}}{\tau_{t,\text{sld}}} = 3 \left( \frac{2300 \text{ kg/m}^3 \times 700 \text{ J/kg}\cdot\text{K}}{10,000 \text{ kg/m}^3 \times 150 \text{ J/kg}\cdot\text{K}} \right) \frac{1916 \text{ W/m}^2\cdot\text{K}}{302 \text{ W/m}^2\cdot\text{K}} = 20.4 <$$

Hence, the solder responds much more quickly to the convective heating.

(b) From Eq. 5.6, the chip-to-solder temperature difference may be expressed as

Continued ...

**PROBLEM 7.88 (Cont.)**

$$T_{\text{ch}} - T_{\text{sld}} = (T_i - T_\infty) \left\{ \exp \left[ - \left( \frac{2\bar{h}}{\rho c t} \right)_{\text{ch}} t \right] - \exp \left[ - \left( \frac{6\bar{h}}{\rho c D} \right)_{\text{sld}} t \right] \right\}$$

$$T_{\text{ch}} - T_{\text{sld}} = 60^\circ\text{C} \left\{ \exp \left[ - \frac{604 \text{ W/m}^2 \cdot \text{K}}{1610 \text{ J/m}^2 \cdot \text{K}} 0.25 \text{ s} \right] - \exp \left[ - \frac{11,496 \text{ W/m}^2 \cdot \text{K}}{1500 \text{ J/m}^2 \cdot \text{K}} 0.25 \text{ s} \right] \right\}$$

$$T_{\text{ch}} - T_{\text{sld}} = 60^\circ\text{C} \{0.910 - 0.147\} = 45.8^\circ\text{C} \quad <$$

**COMMENTS:** (1) The foregoing process is used to subject soldered chip connections (a major reliability issue) to rapid and intense thermal stresses. (2) Some heat transfer by conduction will occur between the chip and solder balls, thereby reducing the temperature difference and thermal stress. (3) Constriction of flow between the chip and substrate will reduce  $\bar{h}_{\text{sld}}$ , as well as  $\bar{h}_{\text{ch}}$  at the lower surface of the chip, relative to values predicted by the correlations. The corresponding time constants would be increased accordingly. (4) With  $\text{Bi}_{\text{ch}} = \bar{h}_{\text{ch}} (t/2) / k_{\text{chip}} = 0.001 \ll 1$  and  $\text{Bi}_{\text{sld}} = \bar{h}_{\text{sld}} (D/6) / k_{\text{sld}} = 0.008 \ll 1$ , the lumped capacitance analysis is appropriate for both components.

### PROBLEM 7.89

**KNOWN:** Conditions associated with Example 7.7, but with reduced longitudinal and transverse pitches.

**FIND:** (a) Air side convection coefficient, (b) Tube bundle pressure drop, (c) Heat rate.

**SCHEMATIC:**

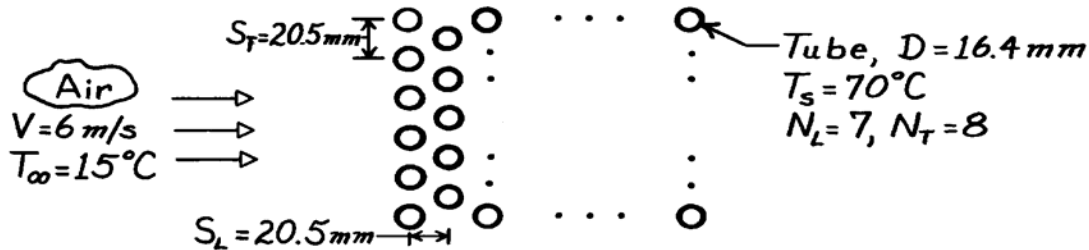

**ASSUMPTIONS:** (1) Steady-state conditions, (2) Uniform tube surface temperature, (3) Negligible radiation and incompressible flow.

**PROPERTIES:** Table A-4, Atmospheric air ( $T_\infty = 288$  K):  $\rho = 1.217$  kg/m<sup>3</sup>,  $\nu = 14.82 \times 10^{-6}$  m<sup>2</sup>/s,  $k = 0.0253$  W/m·K,  $Pr = 0.71$ ,  $c_p = 100.7$  J/kg·K; ( $T_s = 343$  K):  $Pr = 0.701$ .

**ANALYSIS:** (a) From the tube pitches, find

$$S_D = \left[ S_L^2 + (S_T/2)^2 \right]^{1/2} = \left[ (20.5)^2 + (10.25)^2 \right]^{1/2} = 22.91 \text{ mm}$$

$$(S_T + D)/2 = (20.5 + 16.4)/2 = 18.45 \text{ mm.}$$

Hence, the maximum velocity occurs on the transverse plane, and

$$V_{\max} = \frac{S_T}{S_T - D} V = \frac{20.5 \text{ mm}}{(20.5 - 16.4) \text{ mm}} 6 \text{ m/s} = 30 \text{ m/s.}$$

With 
$$Re_{D,\max} = \frac{V_{\max} D}{\nu} = \frac{30 \text{ m/s} (0.0164 \text{ m})}{14.82 \times 10^{-6} \text{ m}^2/\text{s}} = 3.32 \times 10^4$$

and  $(S_T/S_L) = 1 < 2$ , it follows from Table 7.5 that

$$C_1 = 0.35 \quad m = 0.60.$$

Hence, from the Zukauskas correlation and Table 7.6 ( $C_2 = 0.95$ ),

$$\overline{Nu}_D = (0.95) 0.35 Re_{D,\max}^{0.6} Pr^{0.36} (Pr/Pr_s)^{1/4}$$

$$\overline{Nu}_D = (0.95) 0.35 (3.32 \times 10^4)^{0.6} (0.71)^{0.36} (0.71/0.701)^{1/4} = 152$$

$$\bar{h} = \overline{Nu}_D \frac{k}{D} = 152 \times \frac{0.0253 \text{ W/m} \cdot \text{K}}{0.0164 \text{ m}} = 234 \text{ W/m}^2 \cdot \text{K.} \quad <$$

(b) From the Zukauskas relation

$$\Delta p = N_L \chi \left( \frac{\rho V_{\max}^2}{2} \right) f.$$

With  $Re_{D,\max} = 3.32 \times 10^4$ ,  $P_T = (S_T/D) = 1.25$  and  $(P_T/P_L) = 1$ , it follows from Fig. 7.15 that  $\chi \approx 1.02$  and  $f \approx 0.38$ .

Continued ...

### PROBLEM 7.89 (Cont.)

Hence

$$\Delta p = 7 \times 1.02 \frac{1.217 \text{ kg/m}^3 (30 \text{ m/s})^2}{2} 0.38 = 1490 \text{ N/m}^2$$

$$\Delta p = 0.0149 \text{ bar.}$$

<

(c) The air outlet temperature is obtained from

$$T_s - T_o = (T_s - T_i) \exp\left(-\frac{\pi D N \bar{h}}{\rho V N_t S_t c_p}\right)$$

$$T_s - T_o = 55^\circ \text{C} \exp\left(\frac{-\pi (0.0164 \text{ m}) 56 (234 \text{ W/m}^2 \cdot \text{K})}{1.217 \text{ kg/m}^3 \times 6 \text{ m/s} \times 8 \times 0.0205 \text{ m} \times 1007 \text{ J/kg} \cdot \text{K}}\right)$$

$$T_s - T_o = 31.4^\circ \text{C}$$

$$T_o = 38.5^\circ \text{C.}$$

<

The log mean temperature difference is

$$\Delta T_{\ell m} = \frac{\Delta T_i - \Delta T_o}{\ln(\Delta T_i / \Delta T_o)} = \frac{(55 - 31.4)^\circ \text{C}}{\ln(55/31.4)} = 42.1^\circ \text{C}$$

$$q' = N \bar{h} \pi D \Delta T_{\ell m} = 56 (234 \text{ W/m}^2 \cdot \text{K}) \pi (0.0164 \text{ m}) 42.1^\circ \text{C}$$

$$q' = 28.4 \text{ kW/m.}$$

<

**COMMENTS:** Making the tube bank more compact has the desired effect of increasing the convection coefficient and therefore the heat transfer rate. However, it has the adverse effect of increasing the pressure drop and hence the fan power requirement. Note that the convection coefficient increases by a factor of  $(234/135.6) = 1.73$ , while the pressure drop increases by a factor of  $(1490/246) = 6.1$ . This disparity is a consequence of the fact that  $\bar{h} \sim V_{\max}^{0.6}$ , while  $\Delta p \sim V_{\max}^2$ .

Hence any increase in  $V_{\max}$ , which would result from a more closely spaced arrangement, would more adversely affect  $\Delta p$  than favorably affect  $\bar{h}$ .

### PROBLEM 7.90

**KNOWN:** Surface temperature and geometry of a tube bank. Velocity and temperature of air in cross flow.

**FIND:** (a) Total heat transfer, (b) Air flow pressure drop.

**SCHEMATIC:**

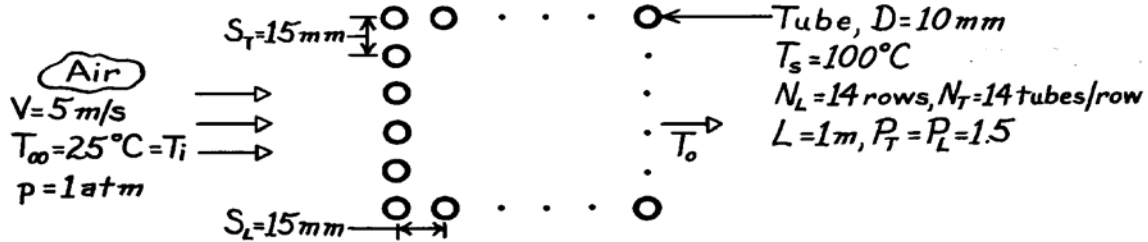

**ASSUMPTIONS:** (1) Steady-state conditions, (2) Negligible radiation and incompressible flow, (3) Uniform surface temperature.

**PROPERTIES:** Table A-4, Atmospheric air ( $T_\infty = 298$  K):  $\nu = 15.8 \times 10^{-6} \text{ m}^2/\text{s}$ ,  $k = 0.0263 \text{ W/m}\cdot\text{K}$ ,  $\text{Pr} = 0.707$ ,  $c_p = 1007 \text{ J/kg}\cdot\text{K}$ ,  $\rho = 1.17 \text{ kg/m}^3$ ; ( $T_s = 373$  K):  $\text{Pr} = 0.695$ .

**ANALYSIS:** (a) The total heat transfer rate is

$$q = \bar{h} N \pi D L \frac{(T_s - T_i) - (T_s - T_o)}{\ln[(T_s - T_i)/(T_s - T_o)]} = \bar{h} N \pi D L \Delta T_{\ell m}$$

$$\text{With } V_{\max} = \frac{S_T}{S_T - D} V = \frac{15 \text{ mm}}{5 \text{ mm}} 5 \text{ m/s} = 15 \text{ m/s}, \text{Re}_{D, \max} = \frac{15 \text{ m/s}(0.01 \text{ m})}{15.8 \times 10^{-6} \text{ m}^2/\text{s}} = 9494. \quad \text{Tables 7.5}$$

and 7.6 give  $C_1 = 0.27$ ,  $m = 0.63$  and  $C_2 \approx 0.99$ . Hence, from the Zukauskas correlation

$$\bar{\text{Nu}}_D = 0.99 \times 0.27 (9494)^{0.63} (0.707)^{0.36} (0.707/0.695)^{1/4} = 75.9$$

$$\bar{h} = \bar{\text{Nu}}_D k/D = 75.9 \times 0.0263 \text{ W/m}\cdot\text{K}/0.01 \text{ m} = 200 \text{ W/m}^2 \cdot \text{K}$$

$$T_s - T_o = (T_s - T_i) \exp\left(-\frac{\pi D N \bar{h}}{\rho V N_T S_T c_p}\right) = 75^\circ\text{C} \exp\left(-\frac{\pi \times 0.01 \text{ m} \times 196 \times 200 \text{ W/m}^2 \cdot \text{K}}{1.17 \text{ kg/m}^3 \times 5 \text{ m/s} \times 14 \times 0.015 \text{ m} \times 1007 \text{ J/kg}\cdot\text{K}}\right)$$

$$T_s - T_o = 27.7^\circ\text{C}.$$

Hence

$$q = 200 \text{ W/m}^2 \cdot \text{K} \times 196 \pi (0.01 \text{ m}) 1 \text{ m} \frac{75^\circ\text{C} - 27.7^\circ\text{C}}{\ln(75/27.7)} = 58.5 \text{ kW}. \quad <$$

(b) With  $\text{Re}_{D, \max} = 9494$ ,  $(P_T - 1)/(P_L - 1) = 1$ , Fig. 7.14 yields  $f \approx 0.32$  and  $\chi = 1$ . Hence,

$$\Delta p = N \chi \left( \rho V_{\max}^2 / 2 \right) f = 14 \times 1 \left( \frac{1.17 \text{ kg/m}^3 (15 \text{ m/s})^2}{2} \right) 0.32$$

$$\Delta p = 590 \text{ N/m}^2 = 5.9 \times 10^{-3} \text{ bar}.$$

**COMMENTS:** The heat transfer rate would have been substantially overestimated (93.3 kW) if the inlet temperature difference ( $T_s - T_i$ ) had been used in lieu of the log-mean temperature difference.

## PROBLEM 7.91

**KNOWN:** Surface temperature and geometry of a tube bank. Inlet velocity and inlet and outlet temperatures of air in cross flow over the tubes.

**FIND:** Number of tube rows needed to achieve the prescribed outlet temperature and corresponding pressure drop of air.

**SCHEMATIC:**

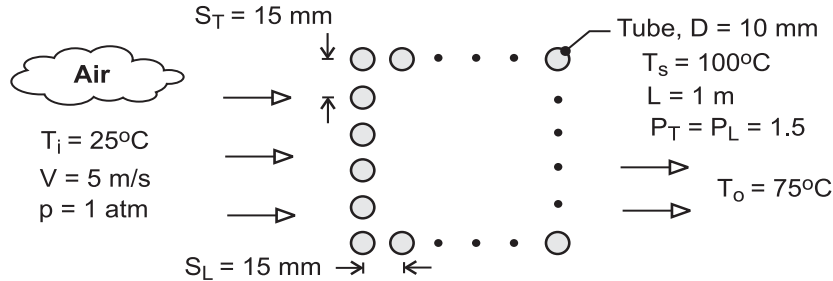

**ASSUMPTIONS:** (1) Steady-state, (2) Negligible temperature drop across tube wall and uniform outer surface temperature, (3) Constant properties, (4)  $C_2 \approx 1$ , (5) Negligible radiation and incompressible flow.

**PROPERTIES:** Table A-4, Atmospheric air. ( $\bar{T} = (T_i + T_o)/2 = 323\text{K}$ ):  $\rho = 1.085\text{ kg/m}^3$ ,

$c_p = 1007\text{ J/kg}\cdot\text{K}$ ,  $\nu = 18.2 \times 10^{-6}\text{ m}^2/\text{s}$ ,  $k = 0.028\text{ W/m}\cdot\text{K}$ ,  $Pr = 0.707$ ; ( $T_i = 298\text{K}$ ):  $\rho = 1.17\text{ kg/m}^3$ ; ( $T_s = 373\text{K}$ ):  $Pr_s = 0.695$ .

**ANALYSIS:** The temperature difference ( $T_s - T$ ) decreases exponentially in the flow direction, and at the outlet

$$\frac{T_s - T_o}{T_s - T_i} = \exp\left(-\frac{\pi D N_L \bar{h}}{\rho V S_T c_p}\right)$$

where  $N_L = N/N_T$ . Hence,

$$N_L = -\frac{\rho V S_T c_p}{\pi D \bar{h}} \ln\left(\frac{T_s - T_o}{T_s - T_i}\right) \quad (1)$$

With  $V_{\max} = [S_T / (S_T - D)]V = 15\text{ m/s}$ ,  $Re_{D,\max} = V_{\max} D / \nu = 8240$ . Hence, with  $S_T / S_L = 1 > 0.7$ ,  $C_1 = 0.27$  and  $m = 0.63$  from Table 7.5, and the Zukauskas correlation yields

$$\overline{Nu}_D = C_1 C_2 Re_{D,\max}^m Pr^{0.36} \left(\frac{Pr}{Pr_s}\right)^{1/4} = 0.27 \times 1 (8240)^{0.63} (0.707)^{0.36} (0.707/0.695)^{1/4} = 70.1$$

$$\bar{h} = \frac{k}{D} \overline{Nu}_D = \frac{0.028\text{ W/m}\cdot\text{K}}{0.01\text{ m}} 70.1 = 196.3\text{ W/m}^2\cdot\text{K}$$

Hence,

$$N_L = -\frac{1.17\text{ kg/m}^3 (5\text{ m/s}) 0.015\text{ m} (1007\text{ J/kg}\cdot\text{K})}{\pi (0.01\text{ m}) 196.3\text{ W/m}^2\cdot\text{K}} \ln\left(\frac{25}{75}\right) = 15.7$$

and 16 tube rows should be used

$$N_L = 16$$

<

With  $Re_{D,\max} = 8240$ ,  $P_L = 1.5$  and  $(P_T - 1)/(P_L - 1) = 1$ ,  $f \approx 0.35$  and  $\chi = 1$  from Fig. 7.14. Hence,

$$\Delta p \approx N_L \chi \left(\frac{\rho V_{\max}^2}{2}\right) f = 16 \left[\frac{1.085\text{ kg/m}^3 \times (15\text{ m/s})^2}{2}\right] 0.35 = 684\text{ N/m}^2 \quad <$$

**COMMENTS:** (1) With  $C_2 = 0.99$  for  $N_L = 16$  from Table 7.8, assumption 4 is appropriate. (2) Note use of the density evaluated at  $T_i = 298\text{K}$  in Eq. (1).



## PROBLEM 7.92

**KNOWN:** Geometry, surface temperature, and air flow conditions associated with a tube bank.

**FIND:** Rate of heat transfer per unit length.

**SCHEMATIC:**

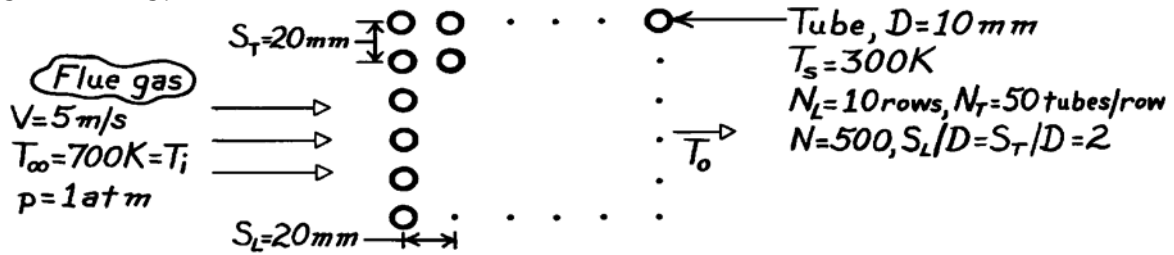

**ASSUMPTIONS:** (1) Steady-state conditions, (2) Negligible radiation effects and incompressible flow, (3) Gas properties are approximately those of air.

**PROPERTIES:** Table A-4, Air (300K, 1 atm):  $Pr = 0.707$ ; Table A-4, Air (700K, 1 atm):  $\nu = 68.1 \times 10^{-6} \text{ m}^2/\text{s}$ ,  $k = 0.0524 \text{ W/m}\cdot\text{K}$ ,  $Pr = 0.695$ ,  $\rho = 0.498 \text{ kg/m}^3$ ,  $c_p = 1075 \text{ J/kg}\cdot\text{K}$ .

**ANALYSIS:** The rate of heat transfer per unit length of tubes is

$$q' = \bar{h}N\pi D \Delta T_{\ell m} = \bar{h}N\pi D \frac{(T_s - T_i) - (T_s - T_o)}{\ln[(T_s - T_i)/(T_s - T_o)]}$$

$$\text{With } V_{\max} = \frac{S_T}{S_T - D} V = \frac{20}{10} 5 \text{ m/s} = 10 \text{ m/s}, \text{Re}_{D,\max} = \frac{V_{\max} D}{\nu} = \frac{10 \text{ m/s} \times 0.01 \text{ m}}{68.1 \times 10^{-6} \text{ m}^2/\text{s}} = 1468.$$

Tables 7.5 and 7.6 give  $C_1 = 0.27$ ,  $m = 0.63$  and  $C_2 = 0.97$ . Hence from the Zukauskas correlation,

$$\overline{Nu}_D = C_1 C_2 \text{Re}_{D,\max}^m Pr^{0.36} (Pr/Pr_s)^{1/4} = 0.26(1468)^{0.63} (0.695)^{0.36} (0.695/0.707)^{1/4}$$

$$\overline{Nu}_D = 22.4 \quad \bar{h} = \frac{k}{D} \overline{Nu}_D = 0.0524 \text{ W/m}\cdot\text{K} \times 22.4/0.01 \text{ m} = 117 \text{ W/m}^2 \cdot \text{K}.$$

Hence,

$$(T_s - T_o) = (T_s - T_i) \exp\left(-\frac{\pi DN \bar{h}}{\rho V N_T S_T c_p}\right) = -400 \text{ K} \exp\left(-\frac{\pi \times 0.01 \text{ m} \times 500 \times 117 \text{ W/m}^2 \cdot \text{K}}{0.498 \text{ kg/m}^3 (5 \text{ m/s}) 50 (0.02 \text{ m}) 1075 \text{ J/kg}\cdot\text{K}}\right)$$

$$T_s - T_o = -201.3 \text{ K}$$

and the heat rate is

$$q' = \left(117 \text{ W/m}^2 \cdot \text{K}\right) 500 \pi (0.01 \text{ m}) \frac{(-400 + 201.3) \text{ K}}{\ln[(-400)/(-201.3)]} = -532 \text{ kW/m} \quad <$$

**COMMENTS:** (1) There is a significant decrease in the gas temperature as it passes through the tube bank. Hence, the heat rate would have been substantially overestimated (- 768 kW) if the inlet temperature difference had been used in lieu of the log-mean temperature difference. (2) The negative sign implies heat transfer to the water. (3) If the temperature of the water increases substantially, the assumption of uniform  $T_s$  becomes poor. The extent to which the water temperature increases depends on the water flow rate.

## PROBLEM 7.93

**KNOWN:** An air duct heater consists of an aligned arrangement of electrical heating elements with  $S_L = S_T = 24$  mm,  $N_L = 3$  and  $N_T = 4$ . Atmospheric air with an upstream velocity of 12 m/s and temperature of 25°C moves in cross flow over the elements with a diameter of 12 mm and length of 250 mm maintained at a surface temperature of 350°C.

**FIND:** (a) The total heat transfer to the air and the temperature of the air leaving the duct heater, (b) The pressure drop across the element bank and the fan power requirement, (c) Compare the average convection coefficient obtained in part (a) with the value for an isolated (single) element; explain the relative difference between the results; (d) What effect would increasing the longitudinal and transverse pitches to 30 mm have on the exit temperature of the air, the total heat rate, and the pressure drop?

**SCHEMATIC:**

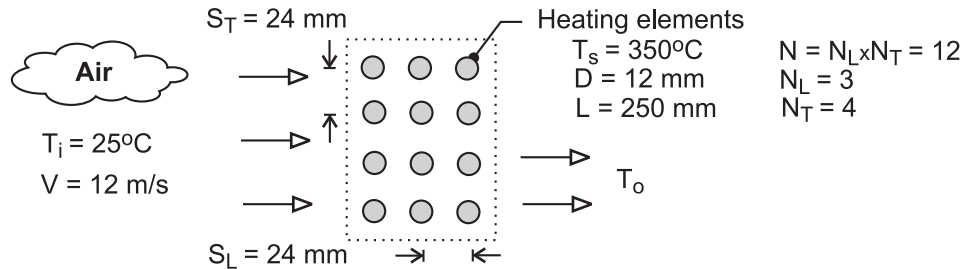

**ASSUMPTIONS:** (1) Steady-state conditions, (2) Negligible radiation effects, (3) Negligible effect of change in air temperature across tube bank on air properties.

**PROPERTIES:** Table A-4, Air ( $T_i = 298$ , 1 atm):  $\rho = 1.171$  kg/m<sup>3</sup>,  $c_p = 1007$  J/kg·K; Air ( $T_m = (T_i + T_o)/2 = 309$  K, 1 atm):  $\rho = 1.130$  kg/m<sup>3</sup>,  $c_p = 1007$  J/kg·K,  $\mu = 1.89 \times 10^{-5}$  N·s/m<sup>2</sup>,  $k = 0.02699$  W/m·K,  $Pr = 0.7057$ ; Air ( $T_s = 623$  K, 1 atm):  $Pr_s = 0.687$ ; Air ( $T_f = (T_i + T_o)/2 = 461$  K, 1 atm):  $\nu = 3.373 \times 10^{-5}$  m<sup>2</sup>/s,  $k = 0.03801$  W/m·K,  $Pr = 0.686$ .

**ANALYSIS:** (a) The total heat transfer to the air is determined from the rate equation

$$q = N(\bar{h}_D \pi D \Delta T_{\ell m}) \quad (1)$$

where the log mean temperature difference is

$$\Delta T_{\ell m} = \frac{T_s - T_i}{T_s - T_o} \ln \frac{(T_s - T_i)}{(T_s - T_o)} \quad (2)$$

and from the overall energy balance,

$$\frac{T_s - T_o}{T_s - T_i} = \exp\left(\frac{\pi D N \bar{h}_D}{\rho V N_T S_T c_p}\right) \quad (3)$$

The properties  $\rho$  and  $c_p$  in Eq. (3) are evaluated at the inlet temperature  $T_i$ . The average convection coefficient using the Zukauskus correlation,

$$\overline{Nu}_D = \frac{\bar{h}_D}{k} = C Re_{D,\max}^m Pr^{0.36} (Pr/Pr_s)^{1/4} \quad (4)$$

where  $C_1 = 0.27$ ,  $m = 0.63$  are determined from Table 7.5 for the *aligned* configuration with  $S_T/S_L = 1 > 0.7$  and  $10^3 < Re_{D,\max} \leq 10^5$ . All properties except  $Pr_s$  are evaluated at the arithmetic mean temperature  $T_m = (T_i + T_o)/2$ . The maximum Reynolds number is

Continued ...

**PROBLEM 7.93 (Cont.)**

$$\text{Re}_{D,\max} = \rho V_{\max} D / \mu \quad (5)$$

where for the *aligned* arrangement, the maximum velocity occurs at the transverse plane

$$V_{\max} = \frac{S_T}{S_T - D} V \quad (6)$$

The results of the analyses for  $S_T = S_L = 24 \text{ mm}$  are tabulated below.

$V_{\max}$ (m/s)	$\text{Re}_{D,\max}$	$\overline{\text{Nu}}_D$	$\overline{h}_D$ (W/m <sup>2</sup> ·K)	$\Delta T_{\ell m}$ (°C)	$q$ (W)	$T_o$ (°C)
24	1.723×10 <sup>4</sup>	96.2	216	314	7671	47.6

<

(b) The pressure drop across the tube bundle is

$$\Delta p = N_L \chi \left( \rho V_{\max}^2 / 2 \right) f \quad (7)$$

where the friction factor,  $f$ , and correction factor,  $\chi$ , are determined from Fig. 7.14 using  $\text{Re}_{D,\max} = 1.723 \times 10^4$ ,

$$f = 0.2 \quad \chi = 1$$

Substituting numerical values,

$$\Delta p = 3 \times 1 \left[ 1.171 \text{ kg/m}^3 \times (24 \text{ m/s})^2 / 2 \right] \times 0.2$$

$$\Delta p = 195 \text{ N/m}^2 \quad <$$

The fan power requirement is

$$P = \dot{V} \Delta p = V N_T S_T L \Delta p \quad (8)$$

$$P = 12 \text{ m/s} \times 4 \times 0.024 \text{ m} \times 0.250 \text{ m} \times 195 \text{ N/m}^2$$

$$P = 56 \text{ W} \quad <$$

where  $\dot{V}$  is the volumetric flow rate. For this calculation,  $\rho$  in Eq. (7) was evaluated at  $T_m$ .

(c) For a single element in cross flow, the average convection coefficient can be estimated using the Churchill-Bernstein correlation,

$$\overline{\text{Nu}}_D = \frac{\overline{h}_D D}{k} = 0.3 + \frac{0.62 \text{ Re}_D^{1/2} \text{ Pr}^{1/3}}{\left[ 1 + (0.4/\text{Pr})^{2/3} \right]^{1/4}} \left[ 1 + \left( \frac{\text{Re}_D}{282,000} \right)^{5/8} \right]^{4/5} \quad (9)$$

where all properties are evaluated at the film temperature,  $T_f = (T_i + T_o)/2$ . The results of the calculations are

$$\text{Re}_{D,1} = 4269 \quad \overline{\text{Nu}}_{D,1} = 33.4 \quad \overline{h}_{D,1} = 106 \text{ W/m}^2 \cdot \text{K} \quad <$$

Continued ...

### PROBLEM 7.93 (Cont.)

For the isolated element,  $\bar{h}_{D,1} = 106 \text{ W/m}^2 \cdot \text{K}$ , compared to the average value for the array,  $\bar{h}_D = 216 \text{ W/m}^2 \cdot \text{K}$ . Because the first row of the array acts as a turbulence grid, the heat transfer coefficient for the second and third rows will be larger than for the first row. Here, the array value is twice that for the isolated element.

(d) The effect of increasing the longitudinal and transverse pitches to 30 mm, should be to reduce the outlet temperature, heat rate, and pressure drop. The effect can be explained by recognizing that the maximum Reynolds number will be decreased, which in turn will result in lower values for the convection coefficient and pressure drop. Repeating the calculations of part (a) for  $S_L = S_T = 30 \text{ mm}$ , find

$V_{\max}$ (m/s)	$Re_{D,\max}$	$\overline{Nu}_D$	$\bar{h}_D$ (W/m <sup>2</sup> ·K)	$\Delta T_{\ell m}$ (°C)	$q$ (W)	$T_o$ (°C)
12	$1.46 \times 10^4$	86.7	193	317	6925	41.3

and part (b) for the pressure drop and fan power, find

$$f = 0.18 \qquad \chi = 1 \qquad \Delta p = 122 \text{ N/m}^2 \qquad P = 44 \text{ W}$$

## PROBLEM 7.94

**KNOWN:** Surface temperature and geometry of a tube bank. Velocity and temperature of air in cross-flow.

**FIND:** (a) Air outlet temperature, (b) Pressure drop and fan power requirements.

**SCHEMATIC:**

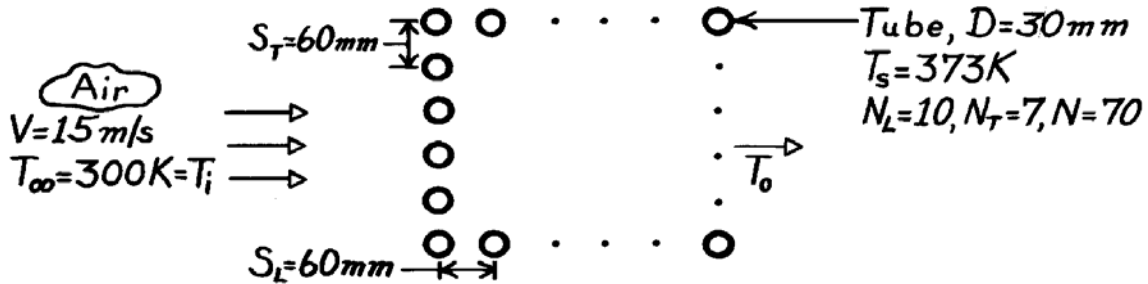

**ASSUMPTIONS:** (1) Steady-state conditions, (2) Negligible radiation, (3) Air pressure is approximately one atmosphere, (4) Uniform surface temperature.

**PROPERTIES:** Table A-4, Air (300 K, 1 atm):  $\rho = 1.1614 \text{ kg/m}^3$ ,  $c_p = 1007 \text{ J/kg}\cdot\text{K}$ ,  $\nu = 15.89 \times 10^{-6} \text{ m}^2/\text{s}$ ,  $k = 0.0263 \text{ W/m}\cdot\text{K}$ ,  $\text{Pr} = 0.707$ ; (373K):  $\text{Pr} = 0.695$ .

**ANALYSIS:** (a) The air temperature increases exponentially, with

$$T_o = T_s - (T_s - T_i) \exp\left(-\frac{\pi D N \bar{h}}{\rho V N_T S_T c_p}\right).$$

$$\text{With } V_{\max} = \frac{S_T}{S_T - D} V = \frac{60}{30} 15 \frac{\text{m}}{\text{s}} = 30 \frac{\text{m}}{\text{s}}; \text{Re}_{D,\max} = \frac{30 \text{ m/s} \times 0.03 \text{ m}}{15.89 \times 10^{-6} \text{ m}^2/\text{s}} = 56,639.$$

Tables 7.5 and 7.6 give  $C_1 = 0.27$ ,  $m = 0.63$  and  $C_2 = 0.97$ . Hence from the Zukauskas correlation,

$$\bar{\text{Nu}}_D = 0.27(0.97)(56,639)^{0.63}(0.707)^{0.36}(0.707/0.695)^{1/4} = 229$$

$$\bar{h} = \bar{\text{Nu}}_D k/D = 229 \times 0.0263 \text{ W/m}\cdot\text{K}/0.03 \text{ m} = 201 \text{ W/m}^2 \cdot \text{K}.$$

Hence,

$$T_o = 373\text{K} - (373 - 300)\text{K} \exp\left(-\frac{\pi \times 0.03 \text{ m} \times 70 \times 201 \text{ W/m}^2 \cdot \text{K}}{1.1614 \text{ kg/m}^3 \times 15 \text{ m/s} \times 7 \times 0.06 \text{ m} \times 1007 \text{ J/kg}\cdot\text{K}}\right)$$

$$T_o = 373\text{K} - 73\text{K} \times 0.835 = 312\text{K} = 39^\circ\text{C}. \quad <$$

(b) With  $\text{Re}_{D,\max} = 5.66 \times 10^4$ ,  $P_L = 2$ ,  $(P_T - 1)/(P_L - 1) = 1$ , Fig. 7.14 yields  $f \approx 0.19$  and  $\chi = 1$ .

Hence,

$$\Delta p = N_L \chi \left(\frac{\rho V_{\max}^2}{2}\right) f = 10 \left(\frac{1.1614 \text{ kg/m}^3 \times (30 \text{ m/s})^2}{2}\right) 0.19 = 993 \text{ N/m}^2 = 0.00993 \text{ bar}. \quad <$$

The fan power requirement is

$$P = \dot{m}_a \Delta p / \rho = \rho V N_T S_T L \Delta p / \rho = 15 \text{ m/s} \times 7 \times 0.06 \text{ m} \times 1 \text{ m} \times 993 \text{ N/m}^2 = 6.26 \text{ kW}. \quad <$$

**COMMENTS:** The heat rate is

$$q = \dot{m}_a c_p (T_o - T_i) = \rho V N_T S_T L c_p (T_o - T_i)$$

$$q = 1.1614 \text{ kg/m}^3 \times 15 \text{ m/s} \times 7 \times 0.06 \text{ m} \times 1 \text{ m} \times 1007 \text{ J/kg}\cdot\text{K} (312 - 300) \text{ K} = 88.4 \text{ kW}.$$

## PROBLEM 7.95

**KNOWN:** Surface temperature and geometry of tube bank. Velocity and temperature of air in cross-flow.

**FIND:** (a) Air outlet temperature, (b) Pressure drop and fan power requirements.

**SCHEMATIC:**

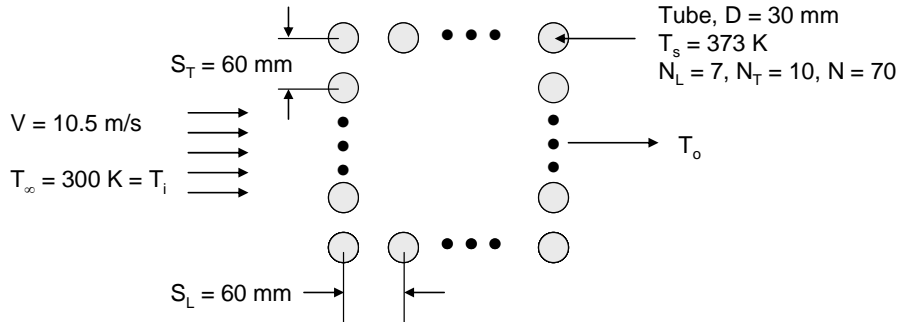

**ASSUMPTIONS:** (1) Steady-state conditions, (2) Negligible radiation, (3) Air pressure approximately one atmosphere, (4) Uniform surface temperature.

**PROPERTIES:** Table A.4, air (300K, 1 atm):  $\nu = 15.89 \times 10^{-6} \text{ m}^2/\text{s}$ ,  $Pr = 0.707$ ,  $k = 0.0263 \text{ W/m}\cdot\text{K}$ ,  $\rho = 1.1614 \text{ kg/m}^3$ ,  $c_p = 1007 \text{ J/kg}\cdot\text{K}$ ; (373 K):  $Pr_s = 0.695$ .

**ANALYSIS:** (a) The outlet air temperature may be found from

$$T_o = T_s - (T_s - T_i) \exp\left(-\frac{\pi DN \bar{h}}{\rho V N_T S_T c_p}\right)$$

$$\text{With } V_{\max} = \frac{S_T}{S_T - D} V = \frac{60}{30} \times 10.5 \text{ m/s} = 21 \text{ m/s}; \quad Re_{D,\max} = \frac{21 \text{ m/s} \times 0.03 \text{ m}}{15.89 \times 10^{-6} \text{ m}^2/\text{s}} = 39,648$$

Tables 7.5 and 7.6 give  $C_1 = 0.27$ ,  $m = 0.63$  and  $C_2 = 0.95$ . From the Zukauskas correlation,

$$\bar{Nu}_D = 0.27 \times 0.95 \times 39,648^{0.63} (0.707)^{0.36} (0.707/0.695)^{1/4} = 179.3$$

$$\bar{h} = \bar{Nu}_D k / D = 179.3 \times 0.0263 \text{ W/m}\cdot\text{K} / 0.03 \text{ m} = 157 \text{ W/m}^2 \cdot \text{K}$$

and therefore,

$$T_o = 373 \text{ K} - 73 \text{ K} \exp\left(-\frac{\pi \times 0.03 \text{ m} \times 70 \times 157 \text{ W/m}^2 \cdot \text{K}}{1.1614 \text{ kg/m}^3 \times 10.5 \text{ m/s} \times 10 \times 0.06 \text{ m} \times 1007 \text{ J/kg}\cdot\text{K}}\right)$$

<

$$= 373 \text{ K} - 73 \text{ K} \times 0.869 = 310 \text{ K} = 37^\circ\text{C}$$

(b) With  $Re_{D,\max} = 39,648$ ,  $P_L = P_T = 2$ ,  $(P_T - 1)/(P_L - 1) = 1$ , Fig. 7.14 yields  $f \approx 0.20$  and  $\chi = 1$ . Therefore,

$$\Delta p = N_L \chi \left(\frac{\rho V_{\max}^2}{2}\right) f = 7 \left(\frac{1.1614 \text{ kg/m}^3 \times (21 \text{ m/s})^2}{2}\right) 0.20 = 359 \text{ N/m}^2$$

and the fan power requirement is

Continued...

### PROBLEM 7.95 (Cont.)

$$P = \dot{m}_a \Delta p / \rho = V N_T S_T L \Delta p = 10.5 \text{ m/s} \times 10 \times 0.06 \text{ m} \times 1 \text{ m} \times 359 \text{ N/m}^2 = 2.26 \text{ kW} \quad <$$

**COMMENTS:** Note that the mass flow rate here is the same as in Problem 7.94. In Problem 7.94, for  $N_L = 7$  and  $N_T = 10$ , the outlet temperature, pressure drop, and fan power requirements are  $T_o = 39^\circ\text{C}$ ,  $\Delta p = 993 \text{ N/m}^2$ , and  $P = 6.26 \text{ kW}$ , respectively. Placing the tube bundle with fewer tubes in the streamwise direction ( $N_L/N_T < 1$ ) results in a higher overall heat transfer rate (lower air outlet temperature) since the downstream tubes experience a larger temperature difference between the tube wall and the flowing air. In addition, a significantly lower pressure drop and pumping power is needed. However, the cross-sectional area of the duct within which the tube bundle is placed must be increased, and therefore capital cost of installation would be higher, for the  $N_L/N_T < 1$  case.

## PROBLEM 7.96

**KNOWN:** Characteristics of pin fin array used to enhance cooling of electronic components. Velocity and temperature of coolant air.

**FIND:** (a) Average convection coefficient for array, (b) Total heat rate and air outlet temperature.

**SCHEMATIC:**

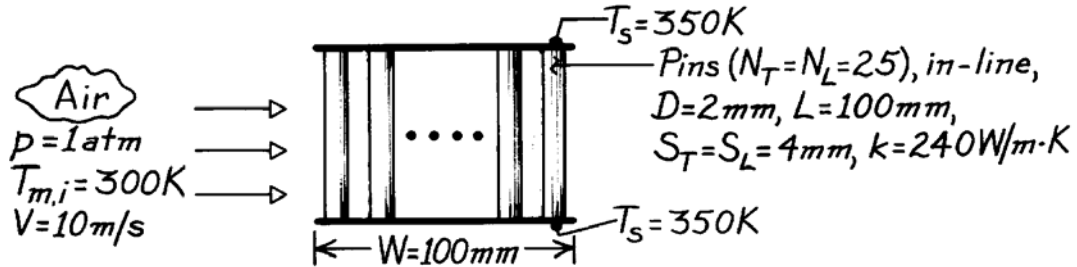

**ASSUMPTIONS:** (1) Steady-state conditions, (2) Negligible radiation, (3) One-dimensional conduction in pins, (4) Uniform plate temperature, (5) Plates have a negligible effect on flow over pins, (6) Uniform convection coefficient over all surfaces, corresponding to average coefficient for flow over a tube bank.

**PROPERTIES:** Air (300 K, 1 atm):  $\rho = 1.1614 \text{ kg/m}^3$ ,  $\text{Pr} = 0.707$ ,  $c_p = 1007 \text{ J/kg}\cdot\text{K}$ ,  $\mu = 184.6 \times 10^{-7} \text{ kg/s}\cdot\text{m}$ ,  $k = 0.0263 \text{ W/m}\cdot\text{K}$ . Aluminum (given):  $k = 240 \text{ W/m}\cdot\text{K}$ .

**ANALYSIS:** (a) From the Zukauskas relation

$$\overline{\text{Nu}}_D = C \text{Re}_{D,\text{max}}^m \text{Pr}^{0.36} (\text{Pr}_\infty / \text{Pr}_s)^{1/4}$$

$$(\text{Pr}_\infty / \text{Pr}_s)^{1/4} \approx 1 \quad V_{\text{max}} = \frac{S_T}{S_T - D} V = \frac{4}{4 - 2} 10 \text{ m/s} = 20 \text{ m/s}$$

$$\text{Re}_{D,\text{max}} = \frac{1.164 \text{ kg/m}^3 \times 20 \text{ m/s} \times 0.002 \text{ m}}{184.6 \times 10^{-7} \text{ kg/s}\cdot\text{m}} = 2517$$

From Table 7.5 find  $C_1 = 0.27$  and  $m = 0.63$ , hence

$$\overline{\text{Nu}}_D = 0.27 (2517)^{0.63} (0.707)^{0.36} = 33.1$$

$$\bar{h} = \overline{\text{Nu}}_D \frac{k}{D} = 33.1 \times \frac{0.0263 \text{ W/m}\cdot\text{K}}{0.002 \text{ m}} = 435 \text{ W/m}^2 \cdot \text{K} \quad <$$

(b) If  $T_s = 350 \text{ K}$  is taken to be the temperature of all of the heat transfer surfaces, correction must be made for the actual temperature drop along the pins. This is done by introducing the overall surface efficiency  $\eta_o$  and replacing  $\bar{h}A$  by  $\bar{h}A_t \eta_o$ . Hence, to obtain the air outlet temperature, we use

$$\frac{T_s - T_o}{T_s - T_i} = \exp\left(-\frac{\bar{h}A_t \eta_o}{\dot{m}c_p}\right)$$

where

Continued ...



**PROBLEM 7.96 (Cont.)**

$$A_t = N(\pi DL) + 2W^2 - 2N(\pi D^2/4)$$

$$A_t = 625(\pi \times 0.002 \text{ m} \times 0.1 \text{ m}) + 2(0.1 \text{ m})^2 - 2 \times 625\pi(0.002 \text{ m})^2/4 = 0.409 \text{ m}^2$$

Also  $\eta_o = 1 - \frac{A_f}{A_t}(1 - \eta_f)$  where  $\eta_f$  is given by Eq. (3.91). With symmetry about the

midplane of the pin,  $q_f = M \tanh(mL/2)$ . Hence

$$\eta_f = \frac{q}{q_{\max}} = \frac{(\bar{h}\pi D k \pi D^2/4)^{1/2} \theta_b \tanh(mL/2)}{\bar{h}\pi D(L/2)\theta_b} = \frac{\tanh(mL/2)}{(\bar{h}/kD)^{1/2} L}$$

or, with  $m = \left[ \bar{h}\pi D / (k\pi D^2/4) \right]^{1/2} = 2(\bar{h}/kD)^{1/2}$ ,

$$\eta_f = \frac{\tanh(mL/2)}{mL/2}$$

$$m = 2 \left( \frac{435 \text{ W/m}^2 \cdot \text{K}}{240 \text{ W/m} \cdot \text{K} \times 0.002 \text{ m}} \right)^{1/2} = 60.2 \text{ m}^{-1}$$

$$mL/2 = 60.2 \text{ m}^{-1} \times 0.05 \text{ m} = 3.01 \quad \text{and} \quad \tanh(mL/2) = 0.995$$

$$\eta_f = \frac{0.995}{3.01} = 0.331.$$

$$\text{Hence, } \eta_o = 1 - \frac{625 \times \pi(0.002 \text{ m})(0.1 \text{ m})}{0.409 \text{ m}^2} (1 - 0.331) = 0.357$$

$$\dot{m} = \rho V L N_T S_T = 1.1614 \text{ kg/m}^3 (10 \text{ m/s}) 0.1 \text{ m} (25) (0.004 \text{ m}) = 0.116 \text{ kg/s}.$$

Now evaluating the air outlet temperature,

$$\frac{T_s - T_o}{T_s - T_i} = \exp\left( - \frac{435 \text{ W/m}^2 \cdot \text{K} \times 0.409 \text{ m}^2 \times 0.357}{0.116 \text{ kg/s} \times 1007 \text{ J/kg} \cdot \text{K}} \right) = 0.581$$

$$T_o = T_s - 0.581(T_s - T_i) = 350 \text{ K} - 0.581(50 \text{ K})$$

$$T_o = 321 \text{ K.} \quad \leftarrow$$

The total heat rate is

$$q = \dot{m} c_p (T_o - T_i) = 0.116 \text{ kg/s} (1007 \text{ J/kg} \cdot \text{K}) 21 \text{ K} = 2453 \text{ W.} \quad \leftarrow$$

**COMMENTS:** (1) The average surface heat flux which can be dissipated by the electronic components is  $q/2W^2 = 122,650 \text{ W/m}^2$ , or  $12.3 \text{ W/cm}^2$ . (2) To check the numerical results, compute

$$\Delta T_{\ell m} = \frac{\Delta T_o - \Delta T_i}{\ln(\Delta T_o / \Delta T_i)} = \frac{29 \text{ K} - 50 \text{ K}}{\ln(29/50)} = 38.6 \text{ K}$$

$$\text{Hence } q = \bar{h} A_t \eta_o \Delta T_{\ell m} = 435 \text{ W/m}^2 \cdot \text{K} \times 0.409 \text{ m}^2 \times 0.357 \times 38.6 \text{ K} = 2449 \text{ W}.$$

## PROBLEM 7.97

**KNOWN:** Dimensions and properties of chip, board and pin fin assembly. Convection conditions for chip and board surface. Maximum allowable chip temperature.

**FIND:** Effect of design and operating conditions on maximum chip power dissipation.

**SCHEMATIC:**

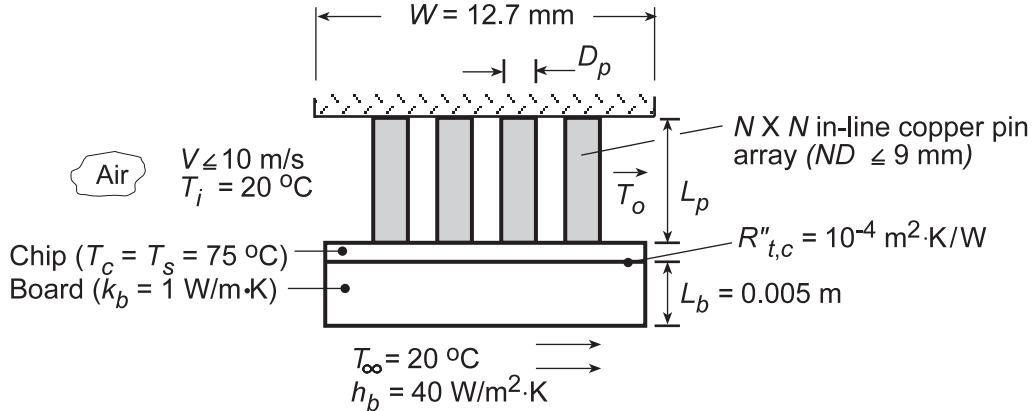

**ASSUMPTIONS:** (1) Uniform chip temperature, (2) One-dimensional conduction in pins, (3) Insulated pin tips, (4) Negligible radiation, (5) Uniform convection coefficient over pin and base surfaces.

**PROPERTIES:** Table A.1, copper ( $T \approx 340$  K):  $k_p = 397$  W/m·K. Table A.4, air: properties evaluated using IHT Properties Tool Pad.

**ANALYSIS:** The chip heat rate may be expressed as

$$q_c = \frac{A_c (T_c - T_\infty)}{\left[ R''_{t,c} + (L_b/k_b) + (1/h_b) \right]} + q_t$$

where  $A_c = W^2$  and  $q_t$  is the total heat rate for the fin array. This heat rate must account for the variation of the air temperature across the array. Hence, the appropriate driving potential is

$\Delta T_{lm} = [(T_c - T_i) - (T_c - T_o)] / \ln [(T_c - T_i) / (T_c - T_o)]$ . However, the total surface area must account for the finite pin length and the exposed base (prime) surface. Hence, from Eqs. 3.106 and 3.107, with  $\Delta T_{lm}$  replacing  $\theta_b$ ,

$$q_t = \bar{h} A_t \eta_o \Delta T_{lm}$$

where  $A_t = N^2 A_f + A_b$ ,  $A_b = A_c - N^2 A_{p,c}$ ,  $A_{p,c} = \pi D_p^2 / 4$  and

$$\eta_o = 1 - \frac{N^2 A_f}{A_t} (1 - \eta_f)$$

For an adiabatic tip, Eq. 3.100 yields

$$\eta_f = \frac{\tanh mL_p}{mL_p}$$

where  $m = (4\bar{h}/k_p D_p)^{1/2}$ . The air outlet temperature is given by the expression

$$\frac{T_c - T_o}{T_c - T_i} = \exp \left( - \frac{\bar{h} A_t \eta_o}{\dot{m} c_p} \right)$$

Continued...

### PROBLEM 7.97 (Cont.)

where  $\dot{m} = \rho V W L_p$  and  $\bar{h}$  is obtained from the Zukauskas correlation,

$$\overline{Nu}_D = C_1 C_2 Re_{D,\max}^m Pr^{0.36} (Pr/Pr_s)^{1/4}$$

The foregoing model, including the convection correlation, was entered from the keyboard into the workspace of IHT and used with the *Properties* Tool Pad to perform the following parametric calculations.

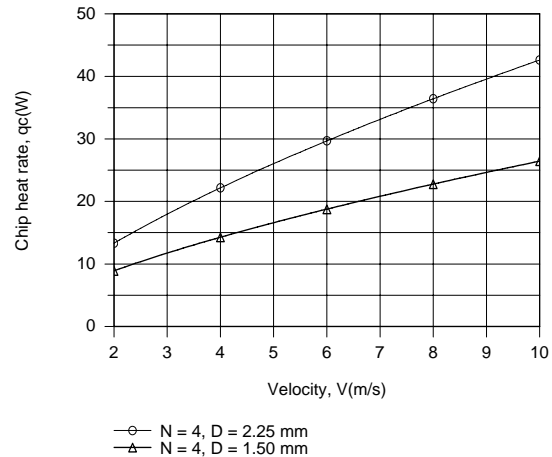
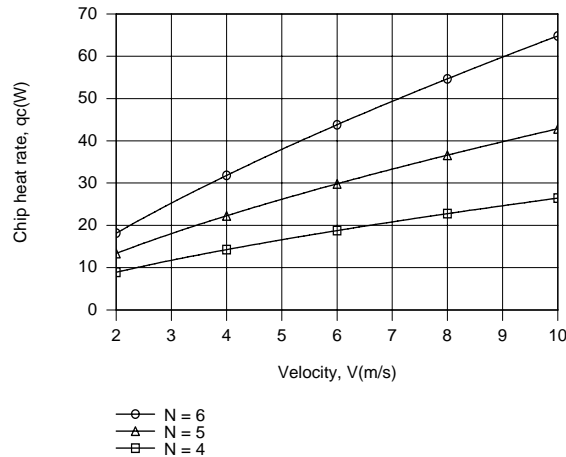

Remaining within the limit  $ND_p \leq 9$  mm, there is clearly considerable benefit associated with increasing  $N$  from 4 to 6 for  $D_p = 1.5$  mm or with increasing  $D_p$  from 1.5 to 2.25 mm for  $N = 4$ . However, the best configuration corresponds to  $N = 6$  and  $D_p = 1.5$  mm (a larger number of smaller diameter pins), for which both  $A_t$  and  $\bar{h}$  are approximately 50% and 20% larger than values associated with  $N = 4$  and  $D_p = 2.25$  mm. The peak heat rate is  $q_c = 64.5$  W for  $V = 10$  m/s,  $N = 6$ , and  $D_p = 1.5$  mm.

**COMMENTS:** (1) The heat rate through the board is only  $q_b = 0.295$  W and hence a negligible portion of the total heat rate. (2) Values of  $C = 0.27$  and  $m = 0.63$  were used for the entire range of conditions. However,  $Re_{D,\max}$  was less than 1000 in the mid to low range of  $V$ , for which the correlation was therefore used outside its prescribed limits and the results are somewhat approximate. (3) Using the IHT solver, the model was implemented in three stages, beginning with (i) the correlation and the Properties Tool Pad and sequentially adding (ii) expressions for  $q_t$  and  $(T_c - T_o)/(T_c - T_i)$  without  $\eta_o$ , and (iii) inclusion of  $\eta_o$  in the model. Results computed from one calculation were loaded as initial guesses for the next calculation.

## PROBLEM 7.98

**KNOWN:** Tube geometry and flow conditions for steam condenser. Surface temperature and pressure of saturated steam.

**FIND:** (a) Coolant outlet temperature, (b) Heat and condensation rates, (c) Effects of reducing longitudinal pitch and change in velocity.

**SCHEMATIC:**

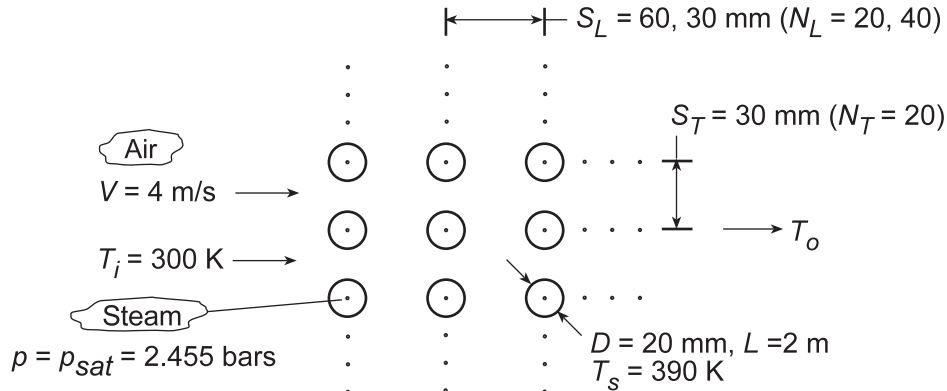

**ASSUMPTIONS:** (1) Steady-state, (2) Negligible radiation, (3) Negligible effect of temperature change on air properties, (parts a and b), (4) Applicability of convection correlation outside designated range.

**PROPERTIES:** Table A.4, air ( $T_i = 300$  K):  $\rho = 1.16$  kg/m<sup>3</sup>,  $c_p = 1007$  J/kg·K,  $\nu = 15.89 \times 10^{-6}$  m<sup>2</sup>/s,  $k = 0.0263$  W/m·K,  $Pr = 0.707$ . ( $T_s = 390$  K):  $Pr = 0.692$ . Table A.6, saturated water at 2.455 bars:  $h_{fg} = 2.183 \times 10^6$  J/kg.

**ANALYSIS:** (a) From Section 7.6,

$$T_o = T_s - (T_s - T_i) \exp\left(-\frac{\pi D N \bar{h}}{\rho V N_T S_T c_p}\right)$$

With

$$V_{\max} = \frac{S_T}{S_T - D} V = \frac{30}{10} 4 \text{ m/s} = 12 \text{ m/s}$$

$$Re_{D,\max} = \frac{V_{\max} D}{\nu} = \frac{12 \text{ m/s} (0.02 \text{ m})}{15.89 \times 10^{-6} \text{ m}^2/\text{s}} = 15,104$$

Using the Zhukauskas correlation outside its designated range ( $S_T/S_L = 0.5$ ), Table 7.5 yields  $C_1 = 0.27$  and  $m = 0.63$ . Hence, with  $C_2 = 1$ ,

$$\bar{Nu}_D = C_1 Re_{D,\max}^m Pr^{0.36} (Pr/Pr_s)^{1/4} = 0.27 (15,104)^{0.63} (0.707)^{0.36} \left(\frac{0.707}{0.692}\right)^{1/4} = 103$$

$$\bar{h} = \bar{Nu}_D (k/D) = 103 (0.0263 \text{ W/m} \cdot \text{K} / 0.02 \text{ m}) = 135 \text{ W/m}^2 \cdot \text{K}$$

$$T_o = 390 \text{ K} - (90 \text{ K}) \exp\left[-\frac{\pi (0.02 \text{ m}) 400 \left(135 \text{ W/m}^2 \cdot \text{K}\right)}{1.16 \text{ kg/m}^3 (4 \text{ m/s}) 20 (0.03 \text{ m}) 1007 \text{ J/kg} \cdot \text{K}}\right] = 363 \text{ K} \quad <$$

(b) With  $q = q' L$ ,

Continued...

### PROBLEM 7.98 (Cont.)

$$q = N(\bar{h}\pi DL\Delta T_{lm})$$

where

$$\Delta T_{lm} = \frac{(T_s - T_i) - (T_s - T_o)}{\ln\left(\frac{T_s - T_i}{T_s - T_o}\right)} = \frac{(90 - 27) \text{ K}}{\ln\left(\frac{90}{27}\right)} = 52.3 \text{ K}$$

$$\text{Hence } q = 400\left(135 \text{ W/m}^2 \cdot \text{K}\right)\pi(0.02 \text{ m})2 \text{ m}(52.3 \text{ K}) = 355 \text{ kW} \quad <$$

The condensation rate is

$$\dot{m}_{\text{cond}} = \frac{q}{h_{fg}} = \frac{3.55 \times 10^5 \text{ W}}{2.183 \times 10^6 \text{ J/kg}} = 0.163 \text{ kg/s} \quad <$$

(c) For  $S_L = 0.03 \text{ m}$ ,  $N_L = 40$  and  $N = 800$ , using IHT with the foregoing model and the Properties Tool Pad to evaluate air properties at  $(T_i + T_o)/2$ , we obtain

$$T_o = 383.6 \text{ K}, \quad \Delta T_{lm} = 31.6 \text{ C}, \quad q = 414 \text{ kW}, \quad \dot{m}_{\text{cond}} = 0.190 \text{ kg/s} \quad <$$

As expected,  $q$  and  $\dot{m}_{\text{cond}}$  increase with increasing  $N_L$ . However, due to a corresponding increase in  $T_o$ , and hence a reduction in  $\Delta T_{lm}$ , the increase is not commensurate with the two-fold increase in surface area for the tube bank.

The effect of velocity is shown below.

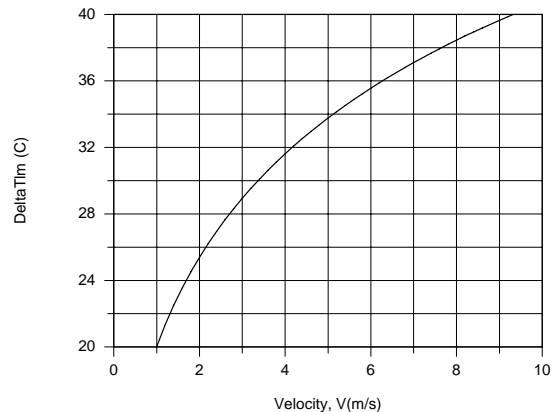
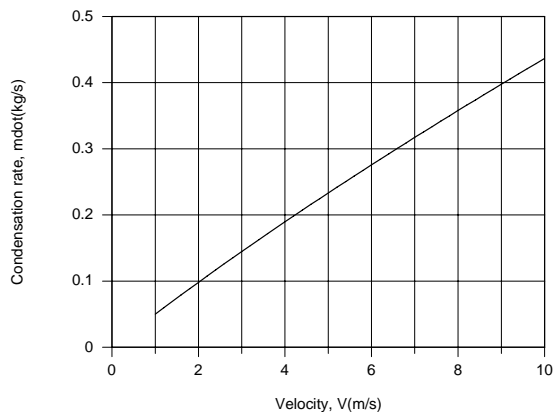

The heat rate, and hence condensation rate, is strongly affected by velocity, because in addition to increasing  $\bar{h}$ , an increase in  $V$  decreases  $T_o$ , and hence increases  $\Delta T_{lm}$ .

**COMMENTS:** (1) The calculations of part (a) should be repeated with air properties evaluated at  $(T_i + T_o)/2$ . (2) the condensation rate could be increased significantly by using a water-cooled (larger  $\bar{h}$ ), rather than an air-cooled, condenser.

## PROBLEM 7.99

**KNOWN:** Temperature of single round air jet.

**FIND:** Minimum jet diameter for which Equation 7.71 can be applied.

**SCHEMATIC:**

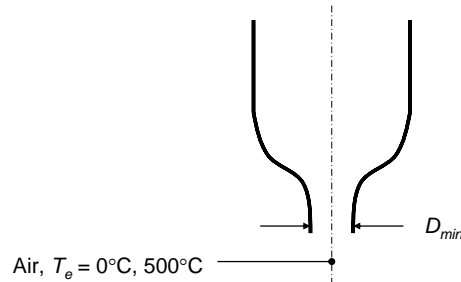

**ASSUMPTIONS:** (1) Steady-state, (2) Constant properties, (3) Air is ideal gas, (4) Flow is incompressible for  $Ma < 0.3$ .

**PROPERTIES:** Table A-4, Air ( $T = 273$  K):  $c_p = 1006.5$  J/kg·K,  $\nu = 13.5 \times 10^{-6}$  m<sup>2</sup>/s; ( $T = 773$  K):  $c_p = 1092.5$  J/kg·K,  $\nu = 80.3 \times 10^{-6}$  m<sup>2</sup>/s.

**ANALYSIS:** (a) Equation 7.71 is restricted to the Reynolds range:

$$2000 \leq Re \leq 400,000$$

With  $Re = VD/\nu$ , this restricts  $VD$ , but does not limit  $D$  directly. Therefore there must be another constraint, namely the flow must be incompressible, which is valid for  $Ma = V/a < 0.3$ , where  $a$  is the speed of sound. The Mach number constraint implies  $V < 0.3a$ , which in turn means that  $Re < 0.3aD/\nu$ . Incorporating the lower Reynolds number limit provides a minimum bound on  $D$ , namely

$$2000 \leq Re < \frac{0.3aD}{\nu}$$

$$D \geq 2000 \frac{\nu}{0.3a}$$

Also, the gas constant for air is  $R \equiv \mathcal{R}/\mathcal{M} = 8315$  J/kmol·K/28.97 kg/kmol = 287 J/kg.

(a) At  $T = 273$  K,  $c_v \equiv c_p - R = 1006.5$  J/kg·K - 287 J/kg·K = 719.5 J/kg·K. The ratio of specific heats is therefore  $\gamma = c_p/c_v = 1006.5$  J/kg·K/719.5 J/kg·K = 1.40 and the speed of sound is  $a = \sqrt{\gamma RT} = \sqrt{1.40 \times 287$  J/kg·K  $\times$  273 K = 331 m/s. Hence the minimum diameter jet is given by

$$D \geq 2000 \frac{13.5 \times 10^{-6} \text{ m}^2/\text{s}}{0.3 \times 331 \text{ m/s}} = 2.7 \times 10^{-4} \text{ m} = 0.27 \text{ mm} \quad <$$

(b) For  $T = 773$  K,  $c_v \equiv c_p - R = 1092.5$  J/kg·K - 287 J/kg·K = 805.5 J/kg·K. The ratio of specific heats is therefore  $\gamma = c_p/c_v = 1092.5$  J/kg·K/805.5 J/kg·K = 1.36 and the speed of sound is  $a = \sqrt{\gamma RT} = \sqrt{1.36 \times 287$  J/kg·K  $\times$  773 K = 549 m/s. Hence the minimum diameter jet is given by

$$D \geq 2000 \frac{80.3 \times 10^{-6} \text{ m}^2/\text{s}}{0.3 \times 549 \text{ m/s}} = 0.00098 \text{ m} = 0.98 \text{ mm} \quad <$$

**COMMENTS:** If jet diameters smaller than these limits are to be used, alternative approaches would need to be taken to estimate the corresponding convection heat transfer rates.

### PROBLEM 7.100

**KNOWN:** Geometry of air jet impingement on a transistor. Jet temperature and velocity. Maximum allowable transistor temperature.

**FIND:** Maximum allowable operating power.

**SCHEMATIC:**

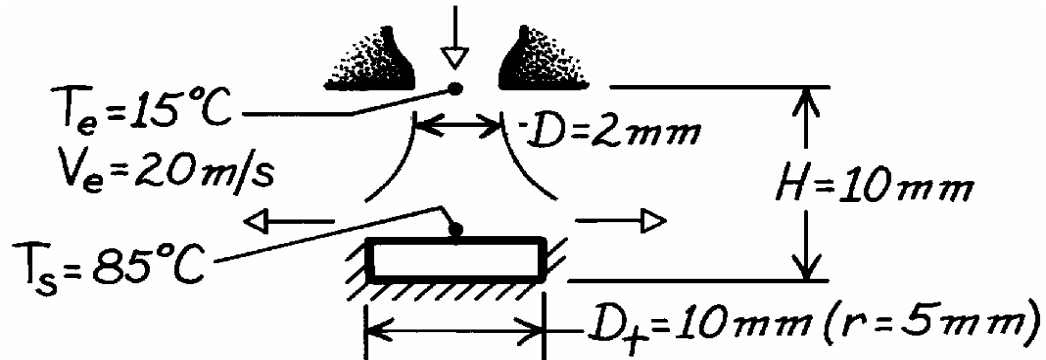

**ASSUMPTIONS:** (1) Steady-state conditions, (2) Isothermal surface, (3) Bell-shaped nozzle, (4) All of the transistor power is dissipated to the jet.

**PROPERTIES:** Table A-4, Air ( $T_f = 323 \text{ K}$ , 1 atm):  $\nu = 18.2 \times 10^{-6} \text{ m}^2/\text{s}$ ,  $k = 0.028 \text{ W/m}\cdot\text{K}$ ,  $\text{Pr} = 0.704$ .

**ANALYSIS:** The maximum power or heat transfer rate by convection is

$$P_{\max} = q_{\max} = \bar{h} \left( \pi D_t^2 / 4 \right) (T_s - T_e)_{\max}$$

For a single round nozzle,

$$\frac{\bar{Nu}}{\text{Pr}^{0.42}} = G(A_r, H/D) F_1(\text{Re})$$

where  $A_r = D^2/4r^2 = 0.04$  and

$$G = Z A_r^{1/2} \frac{1 - 2.2 A_r^{1/2}}{1 + 0.2(H/D - 6) A_r^{1/2}} = 2(0.04)^{1/2} \frac{1 - 2.2(0.04)^{1/2}}{1 + 0.2(5 - 6)(0.04)^{1/2}} = 0.233$$

With

$$\text{Re} = \frac{V_e D}{\nu} = \frac{(20 \text{ m/s}) 0.002 \text{ m}}{18.2 \times 10^{-6} \text{ m}^2/\text{s}} = 2198$$

$$F_1 = 2\text{Re}^{1/2} \left( 1 + 0.005\text{Re}^{0.55} \right)^{1/2} = 2(2198)^{1/2} \left[ 1 + 0.005(2198)^{0.55} \right]^{1/2} = 108.7$$

$$\text{Hence } \bar{h} = \frac{k}{D} G F_1 \text{Pr}^{0.42} = \frac{0.028 \text{ W/m}\cdot\text{K}}{0.002 \text{ m}} (0.233)(108.7)(0.704)^{0.42} = 306 \text{ W/m}^2 \cdot \text{K}$$

$$\text{Hence } P_{\max} = \left( 306 \text{ W/m}^2 \cdot \text{K} \right) \left( \pi / 4 \right) (0.01 \text{ m})^2 (70^\circ\text{C}) = 1.68 \text{ W.} \quad <$$

**COMMENTS:** (1) All conditions required for use of the correlation are satisfied.

(2) Power dissipation may be enhanced by allowing for heat loss through the side and base of the transistor.

## PROBLEM 7.101

**KNOWN:** Dimensions of heated plate and slot jet array. Jet exit temperature and velocity. Initial plate temperature.

**FIND:** Initial plate cooling rate.

**SCHEMATIC:**

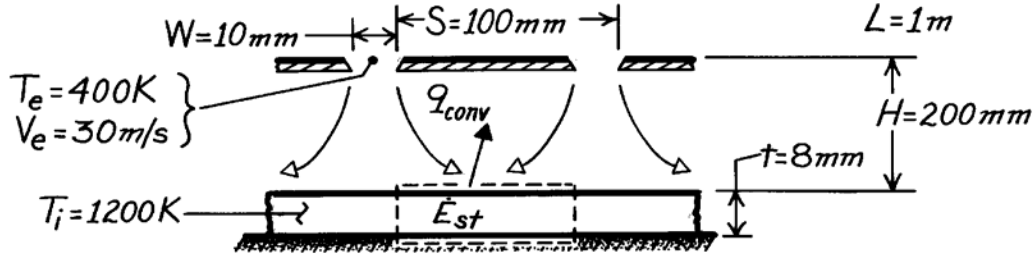

**ASSUMPTIONS:** (a) Negligible variation in  $h$  along plate, (b) Negligible heat loss from back surface of plate, (c) Negligible radiation from front surface of plate.

**PROPERTIES:** Table A-1, AISI 304 Stainless steel (1200 K):  $k = 28.0 \text{ W/m}\cdot\text{K}$ ,  $c_p = 640 \text{ J/kg}\cdot\text{K}$ ,  $\rho = 7900 \text{ kg/m}^3$ ; Table A-4, Air ( $\bar{T}_f = 800 \text{ K}$ ):  $\nu = 84.9 \times 10^{-6} \text{ m}^2/\text{s}$ ,  $k = 0.0573 \text{ W/m}\cdot\text{K}$ ,  $Pr = 0.709$ .

**ANALYSIS:** Performing an energy balance on a control surface about the plate,

$$-q_{\text{conv}} = -\bar{h}A_s(T_i - T_e) = \dot{E}_{\text{st}} = \rho(A_s t)c_p \left(\frac{dT}{dt}\right)_i \quad \left(\frac{dT}{dt}\right)_i = -\frac{\bar{h}(T_i - T_e)}{\rho c_p t}$$

For an array of slot nozzles,

$$\frac{\bar{Nu}}{Pr^{0.42}} = \frac{2}{3} A_{r,o}^{3/4} \left[ \frac{2Re}{A_r / A_{r,o} + A_{r,o} / A_r} \right]^{2/3}$$

where  $A_r = W/S = 0.1$

$$A_{r,o} = \left\{ 60 + 4 \left[ \left( \frac{H}{2W} \right) - 2 \right]^2 \right\}^{-1/2} = \left\{ 60 + 4(64) \right\}^{-1/2} = 0.0563$$

$$Re = \frac{V_e(2W)}{\nu} = \frac{30 \text{ m/s}(0.02 \text{ m})}{84.9 \times 10^{-6} \text{ m}^2/\text{s}} = 7067$$

$$\bar{h} = \frac{0.0573 \text{ W/m}\cdot\text{K}}{0.02 \text{ m}} \frac{2}{3} (0.0563)^{3/4} \left[ \frac{2 \times 7067}{1.776 + 0.563} \right]^{2/3} = 73.2 \text{ W/m}^2 \cdot \text{K}$$

Hence,

$$\left(\frac{dT}{dt}\right)_i = -\frac{73.2 \text{ W/m}^2 \cdot \text{K}(800 \text{ K})}{(7900 \text{ kg/m}^3)(640 \text{ J/kg}\cdot\text{K})(0.008 \text{ m})} = -1.45 \text{ K/s} \quad \leftarrow$$

**COMMENTS:** (1)  $Bi = \bar{h}t/k = (73.2 \text{ W/m}^2 \cdot \text{K})(0.008 \text{ m})/28 \text{ W/m}\cdot\text{K} = 0.02$  and use of the lumped capacitance method is justified.

(2) Radiation may be significant.

(3) Conditions required for use of the correlation are satisfied.



## PROBLEM 7.102

**KNOWN:** Dimensions and material of a cryogenic probe. Temperature and velocity of nitrogen at jet exit. Cancerous tissue thermal conductivity and temperature far from the probe.

**FIND:** (a) Skin surface temperature under probe.

**SCHEMATIC:**

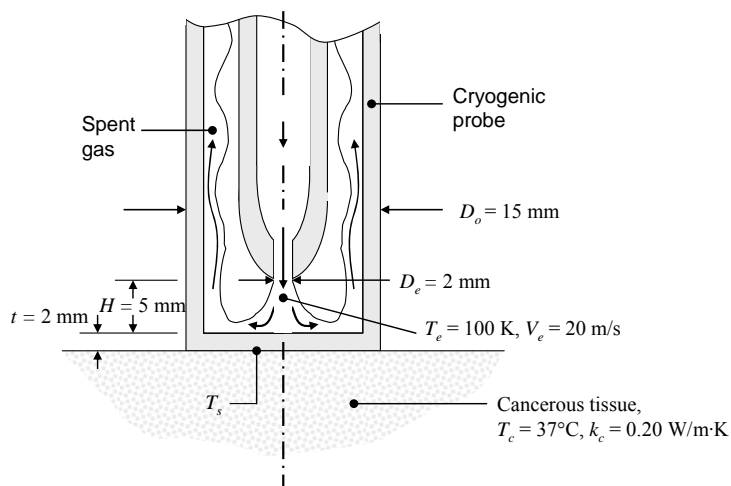

**ASSUMPTIONS:** (1) Steady-state conditions, (2) Constant properties, (3) Negligible contact resistance between skin and probe, (4) Incompressible flow, (5) Due to wall confinement, jet can be modeled as if it were one in an array.

**PROPERTIES:** Table A-4, Nitrogen ( $T \approx 100$  K):  $k = 9.58 \times 10^{-3}$  W/m·K,  $\nu = 2.00 \times 10^{-6}$  m<sup>2</sup>/s,  $Pr = 0.768$ . Table A-1, AISI 302 Stainless Steel ( $T \approx 300$  K):  $k_p = 15.1$  W/m·K.

**ANALYSIS:** (a) The Reynolds number is

$$Re = \frac{V_e D}{\nu} = \frac{20 \text{ m/s} \times 0.002 \text{ m}}{2.00 \times 10^{-6} \text{ m}^2/\text{s}} = 2 \times 10^4$$

The jet behaves as if it were in a staggered array, with the probe walls behaving as if they were the symmetry planes between jets (see Figure 7.18c). Thus  $S = D_o - 2t = 11$  mm and

$$A_r = \pi D_e^2 / 2\sqrt{3}S^2 = \pi(0.002 \text{ m})^2 / 2\sqrt{3}(0.011 \text{ m})^2 = 0.030 \text{ m}^2$$

Furthermore,  $H/D_e = 2.5$ . Based on all of these values, the correlation for an array of round nozzles is valid. From Equations 7.72 and 7.74,

$$G = 2A_r^{1/2} \frac{1 - 2.2A_r^{1/2}}{1 + 0.2(H/D_e - 6)A_r^{1/2}} = 2(0.030 \text{ m}^2)^{1/2} \frac{1 - 2.2(0.030 \text{ m}^2)^{1/2}}{1 + 0.2(2.5 - 6)(0.030 \text{ m}^2)^{1/2}} = 0.244$$

$$K = \left[ 1 + \left( \frac{H/D_e}{0.6/A_r^{1/2}} \right)^6 \right]^{-0.05} = \left[ 1 + \left( \frac{2.5}{0.6/(0.030 \text{ m})^{1/2}} \right)^6 \right]^{-0.05} = 0.993$$

Thus from Equation 7.73,

Continued...

**PROBLEM 7.102 (Cont.)**

$$\overline{Nu} = 0.5KGR e^{2/3} Pr^{0.42} = 0.5 \times 0.993 \times 0.244 \times (2 \times 10^4)^{2/3} (0.768)^{0.42} = 79.9$$

and

$$\overline{h} = \overline{Nu} k / D_e = 79.9 \times 9.58 \times 10^{-3} \text{ W/m} \cdot \text{K} / 0.002 \text{ m} = 383 \text{ W/m}^2 \cdot \text{K}$$

Next, consider the heat transfer from the cancerous tissue at  $T_c$  to the probe surface, through the probe wall, and from the wall to the jet. The heat transfer rate can be written by considering a sum of thermal resistances, as follows:

$$q = \frac{T_c - T_e}{R_c + R_p + R_{\text{jet}}}$$

In this expression,

$R_c$  is the resistance associated with the semi-infinite cancerous tissue having a disk of diameter  $D_o$  at temperature  $T_s$ , as in Table 4.1, Case 10:

$$R_c = 1/2D_o k_c = 1/(2 \times 0.015 \text{ m} \times 0.2 \text{ W/m} \cdot \text{K}) = 167 \text{ K/W}$$

$R_p$  represents conduction through the probe wall:

$$R_p = t/(k_p \pi D_o^2 / 4) = 0.002 \text{ m} \times 4/(15.1 \text{ W/m} \cdot \text{K} \times \pi \times 0.015^2 \text{ m}^2) = 0.750 \text{ K/W}$$

$$R_{\text{jet}} = 1/(\overline{h} \pi D_o^2 / 4) = 4/(383 \text{ W/m}^2 \cdot \text{K} \times \pi \times 0.015^2 \text{ m}^2) = 14.8 \text{ K/W}$$

The heat transfer rate is

$$q = \frac{(310 - 100)\text{K}}{(167 + 0.75 + 14.8)\text{K} / \text{W}} = 1.15 \text{ W}$$

and  $q = (T_c - T_s)/R_c$ , so that

$$T_s = T_c - qR_c = 310 \text{ K} - 1.15 \text{ W} \times 167 \text{ K} / \text{W} = 118 \text{ K} \quad <$$

**COMMENTS:** (1) The assumption of incompressible flow can be checked as follows. For nitrogen, the gas constant is  $R \equiv \mathcal{R}/M = 8315 \text{ J/kmol} \cdot \text{K} / 28 \text{ kg/kmol} = 297 \text{ J/kg}$ . At 100 K,  $c_v = c_p - R = 1070 \text{ J/kg} \cdot \text{K} - 297 \text{ J/kg} \cdot \text{K} = 773 \text{ J/kg} \cdot \text{K}$ . The ratio of specific heats is therefore  $\gamma = c_p/c_v = 1070 \text{ J/kg} \cdot \text{K} / 773 \text{ J/kg} \cdot \text{K} = 1.38$  and the speed of sound is  $a = \sqrt{1.38 \times 297 \text{ J/kg} \cdot \text{K} \times 100 \text{ K}} = 203 \text{ m/s}$ . Hence the Mach number is  $Ma = V/a = 20 \text{ m/s} / 203 \text{ m/s} = 0.1$ , and the flow may be treated as incompressible.

### PROBLEM 7.103

**KNOWN:** Air at 10 m/s and 15°C is available for cooling hot plastic plate. An array of slotted nozzles with prescribed width, pitch and nozzle-to-plate separation.

**FIND:** (a) Improvement in cooling rate achieved using the slotted nozzle arrangement in place of turbulent air in parallel flow over the plate, (b) Change in heat rates if air velocities were doubled, (c) Air mass rate requirement for the slotted nozzle arrangement.

**SCHEMATIC:**

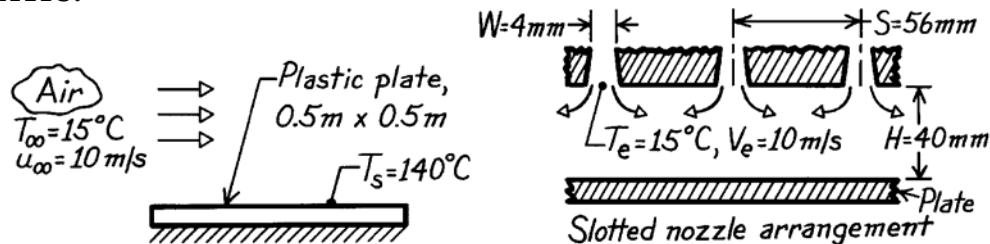

**ASSUMPTIONS:** (1) Steady-state conditions, (2) For parallel flow over plate, flow is turbulent, (3) Negligible radiation effects.

**PROPERTIES:** Table A-4, Air ( $T_f = (140 + 15)^\circ\text{C}/2 = 350\text{ K}$ , 1 atm):  $\rho = 0.995\text{ kg/m}^3$ ,  $\nu = 20.92 \times 10^{-6}\text{ m}^2/\text{s}$ ,  $k = 30.3 \times 10^{-3}\text{ W/m}\cdot\text{K}$ ,  $\text{Pr} = 0.700$ .

**ANALYSIS:** (a) For turbulent flow over the *plate* of length  $L$  with

$$\text{Re}_L = \frac{u_\infty L}{\nu} = \frac{10\text{ m/s} \times 0.5\text{ m}}{20.92 \times 10^{-6}\text{ m}^2/\text{s}} = 2.390 \times 10^5$$

using the turbulent flow correlation, find

$$\overline{\text{Nu}}_L = \frac{\bar{h}L}{k} = 0.037\text{Re}_L^{4/5}\text{Pr}^{1/3} = 0.037(2.390 \times 10^5)^{4/5}(0.700)^{1/3} = 659.6$$

$$\bar{h} = \overline{\text{Nu}}_L k/L = 659.6 \times 0.030\text{ W/m}\cdot\text{K}/0.5\text{ m} = 39.6\text{ W/m}^2\cdot\text{K}.$$

For an array of *slot nozzles*,

$$\overline{\text{Nu}} = \frac{\bar{h}D}{k} = \frac{2}{3}\text{Ar}_{r,o}^{3/4} \left[ \frac{2\text{Re}}{\text{Ar}_r/\text{Ar}_{r,o} + \text{Ar}_{r,o}/\text{Ar}_r} \right]^{2/3} \text{Pr}^{0.42}$$

where 
$$\text{Re} = \frac{V_e D_h}{\nu} = \frac{10\text{ m/s}(2 \times 0.004\text{ m})}{20.92 \times 10^{-6}\text{ m}^2/\text{s}} = 3824$$

$$\text{Ar}_{r,o} = \left\{ 60 + 4 \left[ \left( \frac{H}{2W} \right) - 2 \right]^2 \right\}^{-1/2} = \left\{ 60 + 4 \left[ \frac{40}{2 \times 4} - 2 \right]^2 \right\}^{-1/2} = 0.1021$$

$$\text{Ar}_r = W/S = 4\text{ mm}/56\text{ mm} = 0.0714$$

$$\overline{\text{Nu}} = \frac{2}{3}(0.1021)^{3/4} \left[ \frac{2 \times 3824}{0.0714/0.1021 + 0.1021/0.0714} \right]^{2/3} (0.700)^{0.42} = 24.3$$

$$\bar{h} = \overline{\text{Nu}}k/D_h = 24.3 \times 0.030\text{ W/m}\cdot\text{K}/2 \times 0.004\text{ m} = 91.1\text{ W/m}^2\cdot\text{K}.$$

Continued ...

### PROBLEM 7.103 (Cont.)

The improvement in heat rate with the slot nozzles (sn) over the flat plate (fp) is

$$\frac{q''_{\text{sn}}}{q''_{\text{fp}}} = \frac{\bar{h}_{\text{sn}}}{\bar{h}_{\text{fp}}} = \frac{91.1 \text{ W/m}^2 \cdot \text{K}}{39.6 \text{ W/m}^2 \cdot \text{K}} = 2.3. \quad <$$

(b) If the air velocities were doubled for each arrangement in part (a), the heat transfer coefficients are affected as

$$\bar{h}_{\text{sn}} \sim \text{Re}^{2/3} \quad \bar{h}_{\text{fp}} \sim \text{Re}^{4/5}.$$

Hence

$$\frac{\bar{h}_{\text{sn}}}{\bar{h}_{\text{fp}}} = 2.3 \left( \frac{2^{2/3}}{2^{4/5}} \right) = 2.1. \quad <$$

That is, comparative advantage of the slot nozzle over the flat plate decreases with increasing velocity.

(c) The mass rate of air flow through the array of slot nozzles is

$$\dot{m} = \rho N A_{c,e} = 0.995 \text{ kg/m}^3 \times 9 (0.5 \text{ m} \times 0.004 \text{ m}) 10 \text{ m/s} = 0.179 \text{ kg/s}$$

where the number of slots is determined as

$$N \approx L/S = 0.5 \text{ m} / 0.056 \text{ m} = 8.9 \approx 9. \quad <$$

**COMMENTS:** Note, for the slot nozzle, the hydraulic diameter is  $D_h = 2W$  and the relative nozzle area ( $A_{c,e}/A_{\text{cell}}$ ) is  $A_r = W/S$ .

## PROBLEM 7.104

**KNOWN:** Air jet velocity and temperature of 10 m/s and 15°C, respectively, for cooling hot plastic plate..

**FIND:** Design of optimal round nozzle array. Compare cooling rate with results for a slot nozzle array and flow over a flat plate. Discuss features associated with these three methods relevant to selecting one for this application.

**SCHEMATIC:**

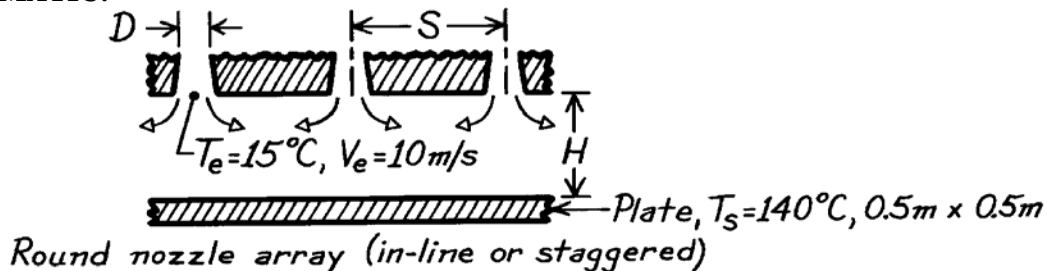

**ASSUMPTIONS:** (1) Steady-state conditions, (2) Negligible radiation effects.

**PROPERTIES:** Table A-4, Air ( $T_f = (140 + 15)^\circ\text{C}/2 = 350\text{ K}$ , 1 atm):  $\rho = 0.995\text{ kg/m}^3$ ,  $\nu = 20.92 \times 10^{-6}\text{ m}^2/\text{s}$ ,  $k = 30.0 \times 10^{-3}\text{ W/m}\cdot\text{K}$ ,  $\text{Pr} = 0.700$ .

**ANALYSIS:** To design an *optimal array* of round nozzles, we require that  $D_{h,op} \approx 0.2H$  and  $S_{op} \approx 1.4H$ . Choose  $H = 40\text{ mm}$ , the nozzle-to-plate separation, hence

$$D_{h,op} = D = 0.2 \times 40\text{ mm} = 8\text{ mm} \quad S_{op} = 1.4 \times 40\text{ mm} = 56\text{ mm}.$$

For an array of round nozzles,

$$\overline{\text{Nu}} = K(A_r, H/D) \cdot G(A_r, H/D) \cdot F_2(\text{Re}) \cdot \text{Pr}^{0.42}$$

where for an *in-line* array, see Fig. 7.18,

$$A_r = \frac{\pi D^2}{4S^2} = \frac{\pi (8\text{ mm})^2}{4(56\text{ mm})^2} = 0.0160$$

$$K = \left[ 1 + \left( \frac{H/D}{0.6/A_r^{1/2}} \right)^6 \right]^{-0.05} = \left[ 1 + \left( \frac{40/8}{0.6/0.0160^{1/2}} \right)^6 \right]^{-0.05} = 0.9577$$

$$G = 2A_r^{1/2} \frac{1 - 2.2A_r}{1 + 0.2(H/D - 6)A_r^{1/2}} = 2 \times 0.0160^{1/2} \frac{1 - 2.2 \times 0.0160}{1 + 0.2(40/8 - 6)0.0160^{1/2}}$$

$$G = 0.2504$$

$$F_2 = 0.5\text{Re}^{2/3} = 0.5 \left( \frac{10\text{ m/s} \times 0.008\text{ m}}{20.92 \times 10^{-6}\text{ m}^2/\text{s}} \right)^{2/3} = 122.2.$$

The average heat transfer coefficient for the *optimal in-line* (op, il) array of round nozzles is,

$$\overline{h}_{op,il} = \overline{\text{Nu}} k/D_{h,op} = \frac{0.030\text{ W/m}\cdot\text{K}}{0.008\text{ m}} \times 0.9577 \times 0.2504 \times 122.2 (0.700)^{0.42}$$

$$\overline{h}_{op,il} = 94.6\text{ W/m}^2 \cdot \text{K}.$$

Continued ...

### PROBLEM 7.104 (Cont.)

If an *optimal staggered* (op,s) array were used, see Fig. 7.18, with

$$A_r = \frac{\pi D^2}{2(3)^{1/2} S^2} = \frac{\pi \times (8 \text{ mm})^2}{2(3)^{1/2} (56 \text{ mm})^2} = 0.0185$$

find  $K = 0.9447$ ,  $G = 0.2632$ ,  $F_2 = 122.2$  and  $\bar{h}_{\text{op,s}} = 100.0 \text{ W/m}^2 \cdot \text{K}$ .

Using the previous results for *parallel flow* (pf) and the *slot nozzle* (sn) array, the heat rates, which are proportional to the average convection coefficients, can be compared.

Arrangement	Flat plate (fp)	Slot nozzle (sn)	Optimal round nozzle (op) In-line (il)	Staggered (s)
$\bar{h}$ , $\text{W/m}^2 \cdot \text{K}$	39.6	91.1	94.6	100.0
$\bar{h}/h_{\text{fp}}$	1.0	2.30	2.39	2.53
$\dot{m}$ , kg/s	---	0.199	0.040	0.046

For these flow conditions, we conclude that there is only slightly improved performance associated with using the round nozzles. As expected, the *staggered* array is better than the *in-line* arrangement, since the former has a higher area ratio ( $A_r$ ). The air flow requirements for the round nozzle arrays are

$$\dot{m} = \rho N A_{c,e} V_e = \rho (A_s / A_{\text{cell}}) A_{c,e} V_e = \rho A_r A_s V_e$$

where  $N = A_s / A_{\text{cell}}$  is the number of nozzles and  $A_s$  is the area of the plate to be cooled. Substituting numerical values, find

$$\dot{m}_{\text{op,il}} = 0.995 \text{ kg/m}^3 \times 0.0160 (0.5 \times 0.5 \text{ m}^2) \times 10 \text{ m/s} = 0.040 \text{ kg/s}$$

$$\dot{m}_{\text{op,s}} = 0.995 \text{ kg/m}^3 \times 0.0185 (0.5 \times 0.5 \text{ m}^2) \times 10 \text{ m/s} = 0.046 \text{ kg/s}.$$

For this application, selection of a nozzle arrangement should be based upon air flow requirements (round nozzles have considerable advantage) and costs associated with fabrication of the arrays (slot nozzle may be easier to form from sheet metal).

## PROBLEM 7.105

**KNOWN:** Exit diameter of plasma generator and radius of jet impingement surface. Temperature and velocity of plasma jet. Temperature of impingement surface. Droplet deposition rate.

**FIND:** Rate of heat transfer to substrate due to convection and release of latent heat.

**SCHEMATIC:**

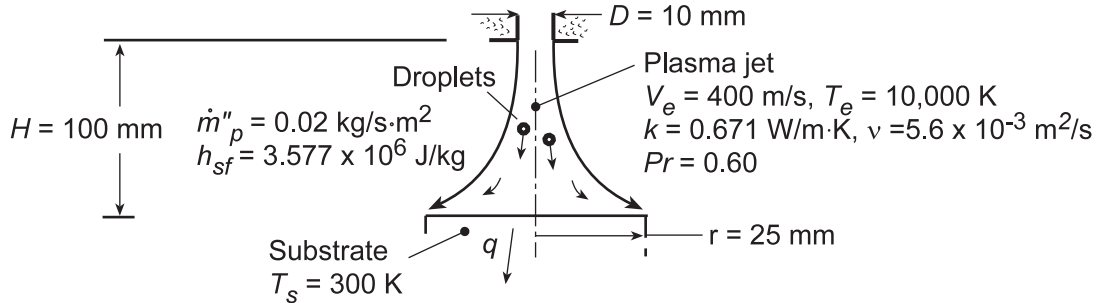

**ASSUMPTIONS:** (1) Steady-state conditions, (2) Negligible radiation, (3) Negligible sensible energy change due to cooling of droplets to  $T_s$ .

**ANALYSIS:** The total heat rate to the substrate is due to convection from the jet and release of the latent heat of fusion due to solidification,  $q = q_{\text{conv}} + q_{\text{lat}}$ . With  $Re = V_e D / \nu = (400 \text{ m/s})0.01 \text{ m} / 5.6 \times 10^{-3} \text{ m}^2/\text{s} = 714$ ,  $A_r = D^2 / 4r^2 = 0.04$ , and  $H/D = 10$ ,  $F_1 = 2Re^{1/2}(1 + 0.005 Re^{0.55})^{1/2} = 58.2$  and  $G =$

$2A_r^{1/2}(1 - 2.2A_r^{1/2}) / [1 + 0.2(H/D - 6)A_r^{1/2}] = 0.193$ , the correlation for a single round nozzle (Section 7.7) yields

$$\overline{Nu} = GF_1 Pr^{0.42} = 0.193(58.2)(0.60^{0.42}) = 9.07$$

$$\bar{h} = \overline{Nu}(k/D) = 9.07(0.671 \text{ W/m} \cdot \text{K} / 0.01 \text{ m}) = 609 \text{ W/m}^2 \cdot \text{K}$$

Hence,

$$q = \bar{h}A_s(T_e - T_s) = 609 \text{ W/m}^2 \cdot \text{K} \times \pi(0.025 \text{ m})^2(10,000 - 300) \text{ K} = 11,600 \text{ W} \quad <$$

The release of latent heat is

$$q_{\text{lat}} = A_s \dot{m}_p'' h_{sf} = \pi(0.025 \text{ m})^2 (0.02 \text{ kg/s} \cdot \text{m}^2) 3.577 \times 10^6 \text{ J/kg} = 140 \text{ W} \quad <$$

**COMMENTS:** (1) The large plasma temperature renders heat transfer due to droplet deposition negligible compared to convection from the plasma. (2) Note that  $Re = 714$  is outside the range of applicability of the correlation, which has therefore been used as an approximation to actual conditions.

## PROBLEM 7.106

**KNOWN:** A round nozzle with a diameter of 1 mm located a distance of 2 mm from the surface mount area with a diameter of 2.5 mm; air jet has a velocity of 70 m/s and a temperature of 500°C.

**FIND:** (a) Estimate the average convection coefficient over the area of the surface mount, (b) Estimate the time required for the surface mount region on the PCB, modeled as a semi-infinite medium initially at 25°C, to reach 183°C; (c) Calculate and plot the surface temperature of the surface mount region for air jet temperatures of 500, 600 and 700°C as a function time for  $0 \leq t \leq 150$  s. Comment on the outcome of your study, the appropriateness of the assumptions, and the feasibility of using the jet for a soldering application.

**SCHEMATIC:**

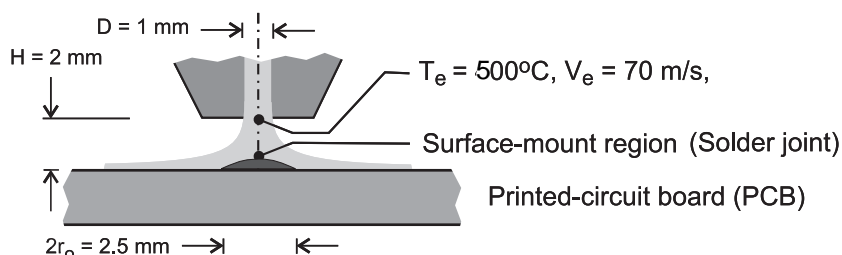

**ASSUMPTIONS:** (1) Air jet is a single round nozzle, (2) Uniform temperature over the PCB surface, and (3) Surface mount region can be modeled as a one-dimensional semiinfinite medium.

**PROPERTIES:** Table A-4, Air ( $T_f = 536$  K, 1 atm):  $\nu = 4.36 \times 10^{-5}$  m<sup>2</sup>/s,  $k = .0497$  W/m·K,  $Pr = 0.6833$ ; Solder (given):  $\rho = 8333$  kg/m<sup>3</sup>,  $c_p = 188$  J/kg·K, and  $k = 51$  W/m·K; eutectic temperature,  $T_{sol} = 183^\circ\text{C}$ ; PCB (given): glass transition temperature,  $T_{gl} = 250^\circ\text{C}$ .

**ANALYSIS:** For a single round nozzle, from the correlation of Eqs. 7.71 and 7.72, estimate the convection coefficient,

$$\frac{\overline{Nu}}{Pr^{0.42}} = G \left( \frac{r}{D}, \frac{H}{D} \right) F_1(Re) \quad \overline{Nu} = \frac{\overline{h}D}{k} \quad (1,2)$$

where

$$F_1 = 2Re^{1/2} \left( 1 + 0.005 Re^{0.55} \right)^{1/2} \quad (3)$$

$$G = 2 A_r^{1/2} \frac{1 - 2.2 A_r^{1/2}}{1 + 0.2(H/D - 6) A_r^{1/2}} \quad (4)$$

$$A_r = D^2 / 4r_o^2 \quad (5)$$

The Reynolds number is based on the jet diameter and velocity at the nozzle,

$$Re_D = V_e D / \nu \quad (6)$$

and  $r_o$  is the radius of the region over which the average coefficient is being evaluated. The thermophysical properties are evaluated at the film temperature,  $T_f = (T_e + T_i)/2$ . The results of the calculation are tabulated below.

Continued ...



### PROBLEM 7.106 (Cont.)

Re	$F_1$	G	$A_F$	$\overline{Nu}$	$\overline{h}$ (W/m <sup>2</sup> ·K)	<
1605	91.01	0.1412	0.16	10.95	470.5	

Consider the surface mount region as a semi-infinite medium, with solder properties, initially at a uniform temperature of 25°C, that experiences sudden exposure to the convection process with the air jet at a temperature  $T_\infty = 500^\circ\text{C}$  and the convection coefficient as found in part (a). The surface temperature,  $T(0,t)$ , is determined from Case 3, Fig. 5.7 and Eq. 5.63,

$$\frac{T(0,t) - T_i}{T_\infty - T_i} = 1 - \exp\left(-\frac{h^2 \alpha t}{k^2}\right) \times \text{erfc}\left(\frac{h(\alpha t)^{1/2}}{k}\right) \quad (7)$$

where  $\alpha = k/\rho c_p$ . With  $T_i = 25^\circ\text{C}$  and  $T_\infty = T_e$ , by trial-and-error, or by using the appropriate *IHT* model, find

$$T(0, t_0) = 183^\circ\text{C} \qquad t_0 = 40.1 \text{ s} \qquad <$$

(c) Using the foregoing relations in *IHT*, the surface temperature  $T(0,t)$  is calculated and plotted for jet air temperatures of 400, 500 and 600°C for  $0 \leq t \leq 40$  s.

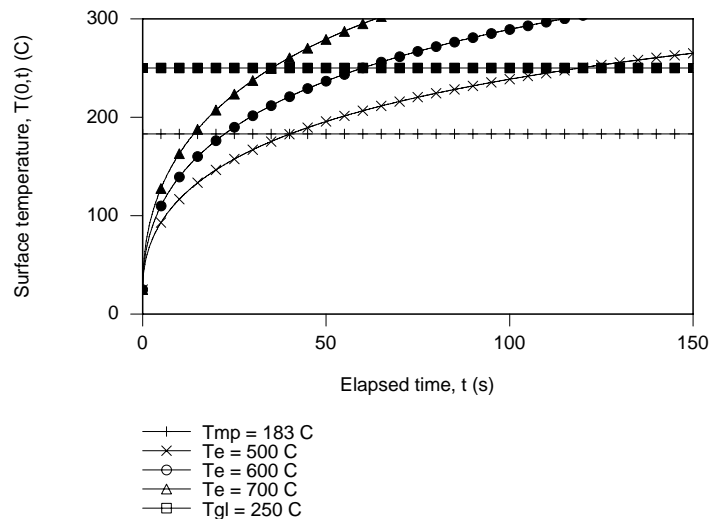

The effect of increasing the jet air temperature is to reduce the time for the surface temperature to reach the solder temperature of 183°C. With the 700°C air jet, it takes about 14 s to reach the solder temperature, and the glass transition temperature is achieved in 35 s. The analysis represents a first-order model giving approximate results only. While the estimates for the average convection coefficients are reasonable, modeling the surface mount region as a semi-infinite medium is an over simplification. The region is of limited extent on the PCB, which is thin and also a poor approximation to an infinite medium. However, the model has provided insight into the conditions under which an air jet could be used for a soldering operation.

**COMMENTS:** (1) Note that for our application, the round nozzle correlation of part (a) exceeds the ranges of validity.

(2) The jet convection coefficient is not strongly dependent upon the air temperature. Values for 500, 600, and 700°C, respectively, are 464, 471, and 458 W/m<sup>2</sup>·K.

## PROBLEM 7.107

**KNOWN:** Diameter and properties of aluminum spheres used in packed bed. Porosity of bed and velocity and temperature of inlet air.

**FIND:** Time for sphere to acquire 90% of maximum possible thermal energy.

**SCHEMATIC:**

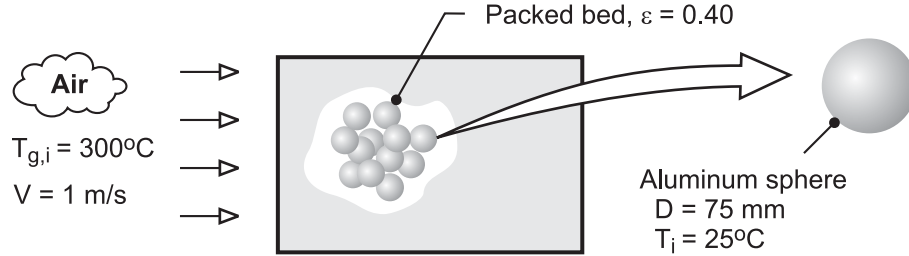

**ASSUMPTIONS:** (1) Negligible heat transfer to or from a sphere by radiation or conduction due to contact with other spheres, (2) Validity of lumped capacitance method, (3) Constant properties.

**PROPERTIES:** Prescribed, Aluminum:  $\rho = 2700 \text{ kg/m}^3$ ,  $c = 950 \text{ J/kg}\cdot\text{K}$ ,  $k = 240 \text{ W/m}\cdot\text{K}$ . *Table A-4*, Air (573K):  $\rho_a = 0.609 \text{ kg/m}^3$ ,  $c_{p,a} = 1045 \text{ J/kg}\cdot\text{K}$ ,  $\nu = 48.8 \times 10^{-6} \text{ m}^2/\text{s}$ ,  $k_a = 0.0453 \text{ W/m}\cdot\text{K}$ ,  $\text{Pr} = 0.684$ .

**ANALYSIS:** From Eqs. 5.7 and 5.8a, achievement of 90% of the maximum possible thermal energy storage corresponds to

$$\frac{Q}{\rho c \nabla \theta_i} = 0.9 = 1 - \exp\left(-\frac{t}{\tau_t}\right) = 1 - \exp\left(-\frac{\bar{h} A_s t}{\rho \nabla c}\right)$$

where the convection coefficient is given by

$$\varepsilon j_H = \varepsilon \bar{\text{St}} \text{Pr}^{2/3} = \varepsilon \frac{\bar{h}}{\rho_a V c_{p,a}} \text{Pr}^{2/3} = 2.06 \text{Re}_D^{-0.575}$$

With  $\text{Re}_D = VD/\nu = 1 \text{ m/s} \times 0.075 \text{ m} / 48.8 \times 10^{-6} \text{ m}^2/\text{s} = 1537$ ,

$$\bar{h} = \frac{2.06 \times 0.609 \text{ kg/m}^3 \times 1 \text{ m/s} \times 1045 \text{ J/kg}\cdot\text{K}}{0.4 (0.684)^{2/3} (1537)^{0.575}} = 62.1 \text{ W/m}^2 \cdot \text{K}$$

Hence, with  $A_s/\nabla = 6/D$ ,

$$t = -\frac{\rho c D}{6\bar{h}} \ln(0.1) = \frac{2700 \text{ kg/m}^3 \times 950 \text{ J/kg}\cdot\text{K} \times 0.075 \text{ m} \times 2.30}{6 \times 62.1 \text{ W/m}^2 \cdot \text{K}} = 1189 \text{ s} \quad <$$

**COMMENTS:** (1) With  $\text{Bi} = \bar{h}(D/6)/k = 0.003$ , the spheres are spatially isothermal and the lumped capacitance approximation is excellent. (2) Before the packed bed becomes fully charged, the temperature of the air decreases as it passes through the bed. Hence, the time required for a sphere to reach a prescribed state of thermal energy storage increases with increasing distance from the bed inlet.

### PROBLEM 7.108

**KNOWN:** Overall dimensions of a packed bed of rocks. Rock diameter and thermophysical properties. Initial temperature of rock and bed porosity. Flow rate and upstream temperature of atmospheric air passing through the pile.

**FIND:** Rate of heat transfer to pile.

**SCHEMATIC:**

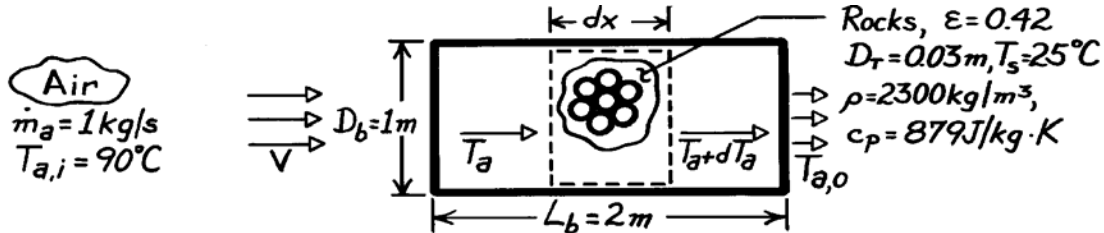

**ASSUMPTIONS:** (1) Rocks are spherical and at a uniform temperature, (2) Steady-state conditions.

**PROPERTIES:** Table A-4, Atmospheric air ( $T_\infty = 363\text{K}$ ):  $\nu = 22.35 \times 10^{-6} \text{ m}^2/\text{s}$ ,  $k = 0.031 \text{ W/m}\cdot\text{K}$ ,  $\text{Pr} = 0.70$ ,  $\rho = 0.963 \text{ kg/m}^3$ ,  $c_p = 1010 \text{ J/kg}\cdot\text{K}$ .

**ANALYSIS:** The heat transfer rate may be expressed as  $q = \bar{h}A_{p,t}\Delta T_{\ell m}$  where the total surface area of the rocks is

$$A_{p,t} = V_r \frac{\pi D_r^2}{\pi D_r^3/6} = (1-\varepsilon) \left( \frac{\pi D_b^2}{4} L_b \right) \frac{6}{D_r} = (1-0.42) \left( \pi (1 \text{ m})^2 \times 2 \text{ m}/4 \right) 6/0.03 \text{ m} = 182.2 \text{ m}^2.$$

The upstream velocity and Reynolds number are

$$V = \frac{\dot{m}_a}{\rho \pi D_b^2/4} = \frac{4 \times 1 \text{ kg/s}}{(0.963 \text{ kg/m}^3) \pi 1 \text{ m}^2} = 1.32 \text{ m/s} \quad \text{Re}_D = \frac{VD_r}{\nu} = \frac{1.32 \text{ m/s} \times 0.03 \text{ m}}{22.35 \times 10^{-6} \text{ m}^2/\text{s}} = 1772.$$

From Section 7.8, it follows that

$$\varepsilon \bar{h} = \varepsilon \bar{St} \text{Pr}^{2/3} = \varepsilon \frac{\bar{h}}{\rho V c_p} \text{Pr}^{2/3} = 2.06 \text{Re}_D^{-0.575}$$

$$\bar{h} = \frac{2.06}{\varepsilon} \rho V c_p \text{Re}_D^{-0.575} \text{Pr}^{-2/3}$$

$$\bar{h} = \frac{2.06}{0.42} 0.963 \text{ kg/m}^3 \times 1.32 \text{ m/s} \times 1010 \text{ J/kg}\cdot\text{K} (1772)^{-0.575} (0.70)^{-2/3} = 108 \text{ W/m}^2 \cdot \text{K}.$$

The appropriate form of the mean temperature difference,  $\Delta T_{\ell m}$ , may be obtained by performing an energy balance on a differential control volume about the rock. That is,

$$\dot{m}_a c_p T_a - \dot{m}_a c_p (T_a + dT_a) - dq_r = 0$$

where  $dq_r = \bar{h}A'_{p,t} dx (T_a - T_s)$  and  $A'_{p,t}$  is the rock surface area per unit length of bed. Hence

$$\dot{m}_a c_p dT_a = -\bar{h}A'_{p,t} dx (T_a - T_s) \quad \frac{dT_a}{dx} = -\frac{\bar{h}A'_{p,t}}{\dot{m}_a c_p} (T_a - T_s).$$

Continued ...

### PROBLEM 7.108 (Cont.)

Integrating between inlet and outlet, it follows that

$$\ln(T_a - T_s) \Big|_i^o = -\frac{\bar{h}A'_{p,t}}{\dot{m}_a c_p} L_b = -\frac{\bar{h}A_{p,t}}{\dot{m}_a c_p} \quad \ln \frac{T_{a,o} - T_s}{T_{a,i} - T_s} = -\frac{\bar{h}A_{p,t}}{\dot{m}_a c_p}$$

With  $q = \dot{m}_a c_p (T_{a,i} - T_{a,o}) = \dot{m}_a c_p [(T_{a,i} - T_s) - (T_{a,o} - T_s)]$

it follows that

$$q = \bar{h}A_{p,t} \frac{(T_{a,i} - T_s) - (T_{a,o} - T_s)}{\ln[(T_{a,i} - T_s)/(T_{a,o} - T_s)]} = \bar{h}A_{p,t} \Delta T_{lm}$$

where 
$$\Delta T_{lm} = \frac{(T_{a,i} - T_s) - (T_{a,o} - T_s)}{\ln[(T_{a,i} - T_s)/(T_{a,o} - T_s)]}$$

The air outlet temperature may be obtained from the requirement

$$\frac{T_{a,o} - T_s}{T_{a,i} - T_s} = \exp\left(-\frac{\bar{h}A_{p,t}}{\dot{m}_a c_p}\right) = \exp\left(-\frac{108 \text{ W/m}^2 \cdot \text{K} \times 182.2 \text{ m}^2}{1 \text{ kg/s} \times 1010 \text{ J/kg} \cdot \text{K}}\right) = 3.46 \times 10^{-9}$$

$$T_{a,o} = 25^\circ \text{C} + 65^\circ \text{C} (3.46 \times 10^{-9}) = 25^\circ \text{C} + 2.25 \times 10^{-7} \text{ }^\circ \text{C}$$

$$T_{a,o} \approx T_s = 25^\circ \text{C}.$$

Hence 
$$\Delta T_{lm} = \frac{65^\circ \text{C} - 2.25 \times 10^{-7} \text{ }^\circ \text{C}}{\ln(65^\circ \text{C} / 2.25 \times 10^{-7} \text{ }^\circ \text{C})} = 3.34^\circ \text{C}$$

and 
$$q = 108 \text{ W/m}^2 \cdot \text{K} (182.2 \text{ m}^2) 3.34^\circ \text{C} = 65.7 \text{ kW}.$$

**COMMENTS:** (1) The above result may be checked from the requirement that  $q =$

$$\dot{m}_a c_p (T_{a,i} - T_{a,o}) = 1 \text{ kg/s} \times 1010 \text{ J/kg} \cdot \text{K} \times 65^\circ \text{C} = 65.7 \text{ kW}.$$

(2) The heat rate would be *grossly* overpredicted by using a rate equation of the form

$$q = \bar{h}A_{p,t} (T_{a,i} - T_s).$$

(3) The foregoing results are reasonable during the early stages of the heating process; however  $q$  would decrease with increasing time as the temperature of the rock increases. The axial temperature distribution of the rock in the pile would be as shown for different times.

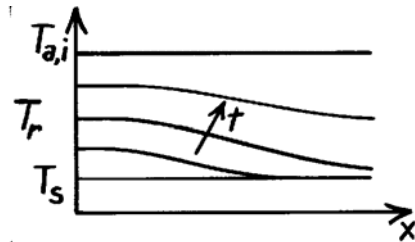

### PROBLEM 7.109

**KNOWN:** Dimensions of a pebble bed nuclear reactor. Dimensions of core and cladding of pellets. Porosity of the reactor and helium properties, inlet temperature, and upstream velocity. Graphite properties. Correlation for convective heat transfer from the spherical pellets in the packed bed.

**FIND:** (a) Mean helium outlet temperature and amount of thermal energy generated per pellet for an overall thermal energy transfer rate of  $q = 125 \text{ MW}$ , (b) Maximum internal temperature of the hottest pellet.

**SCHEMATIC:**

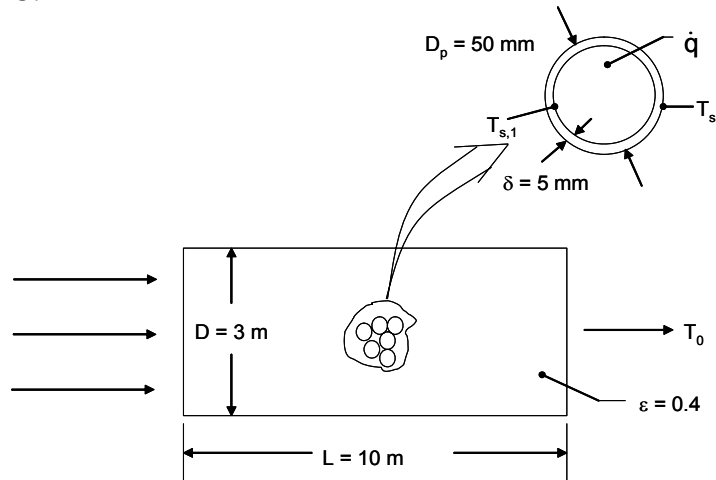

Helium

$V = 3.2 \text{ m/s}$ ,  $T_i = 450^\circ\text{C}$ ,  $P = 40 \text{ bars}$

$c_p = 5193 \text{ J/kg}\cdot\text{K}$ ,  $k = 0.3355 \text{ W/m}\cdot\text{K}$ ,  $\rho = 2.1676 \text{ kg/m}^3$ ,  $\mu = 4.214 \times 10^{-5} \text{ kg/s}\cdot\text{m}$

$Pr = 0.654$

$$\varepsilon \bar{j}_H = 2.876 Re_D^{-1} + 0.3023 Re_D^{-0.35}$$

**ASSUMPTIONS:** (1) Negligible radiation heat transfer, (2) One-dimensional heat transfer, (3) Uniform volumetric thermal generation inside the core, (4) Negligible contact resistance between core and cladding.

**ANALYSIS:**

(a) From the simplified steady-flow thermal energy equation of Chapter 1 we may write

$$q = \dot{m} c_p (T_o - T_i) = \rho A V c_p (T_o - T_i)$$

Thus

$$T_o = T_i + q / \rho A V c_p$$

$$= 450^\circ\text{C} + 125 \times 10^6 \text{ W} / \left( 2.1676 \text{ kg/m}^3 \times \pi \times (0.3 \text{ m}/2)^2 \times 3.2 \text{ m/s} \times 5193 \text{ J/k}\cdot\text{K} \right)$$

$$T_o = 941^\circ\text{C}$$

<

The number of pellets in the chamber is

Continued....

**PROBLEM 7.109 (Cont.)**

$$N = (1 - \varepsilon)(\pi)(D/2)^2 \times L / \left[ \frac{4}{3} \pi \left[ (D_p + 2\delta)/2 \right]^3 \right]$$

$$N = (1 - 0.4) \times (1.5\text{m})^2 \times 10 \text{ m} / \left( \frac{4}{3} \times \left[ (50 \times 10^{-3} \text{ m} + 10 \times 10^{-3} \text{ m})/2 \right]^3 \right)$$

$$N = 375,000$$

The energy generated per pellet is

$$\dot{E}_g = q/N = 125 \times 10^6 \text{ W} / 375,000 = 333 \text{ W}$$

<

(b) The Reynolds number based on the pellet diameter is

$$\text{Re}_D = \frac{\rho V (D_p + 2\delta)}{\mu} = \frac{2.1676 \text{ kg/m}^3 \times 3.2 \text{ m/s} \times (50 \times 10^{-6} \text{ m} + 10 \times 10^{-6} \text{ m})}{4.214 \times 10^{-5} \text{ kg/s} \cdot \text{m}}$$

$$\text{Re}_D = 9876$$

From the problem statement we know

$$\bar{\varepsilon}_{\text{h}} = \varepsilon \frac{\bar{h}}{\rho V c_p} \text{Pr}^{2/3} = \frac{2.876}{\text{Re}_D} + \frac{0.3023}{\text{Re}_D^{0.35}}$$

or

$$\bar{h} = \frac{\rho V c_p}{\varepsilon \text{Pr}^{2/3}} \left[ \frac{2.876}{\text{Re}_D} + \frac{0.3023}{\text{Re}_D^{0.35}} \right]$$

$$\bar{h} = \frac{2.1676 \text{ kg/m}^3 \times 3.2 \text{ m/s} \times 5193 \text{ J/kg} \cdot \text{K}}{0.4 \times (0.654)^{2/3}} \times \left[ \frac{2.876}{9876} + \frac{0.3023}{9876^{0.35}} \right] = 1480 \text{ W/m}^2 \cdot \text{K}$$

A sphere at the exit of the chamber will be adjacent to the highest helium temperature and will be, in turn, the hottest. An energy balance about the single sphere yields

$$q = \bar{h}A(T_s - T_\infty) \quad \text{or} \quad T_s = T_\infty + \frac{q}{\bar{h}A} = T_o + \frac{\dot{E}_g}{\bar{h}\pi(D_p + 2\delta)^2}$$

$$T_s = 941^\circ\text{C} + \frac{333 \text{ W}}{1480 \text{ W/m}^2 \cdot \text{K} \times \pi \times (50 \times 10^{-3} \text{ m} + 10 \times 10^{-3} \text{ m})^2}$$

$$T_s = 960.9^\circ\text{C}$$

The temperature at the inner surface of the cladding may be found using Equation 3.40

$$q_r = \frac{4\pi k(T_{s,1} - T_s)}{\frac{1}{(D_p/2)} - \frac{1}{(D_p/2 + \delta)}}$$

$$T_{s,1} = T_s + q \left[ \frac{1}{(D_p/2)} - \frac{1}{(D_p/2 + \delta)} \right] / 4\pi k$$

Continued....

**PROBLEM 7.109 (Cont.)**

$$T_{s,1} = 960.9^\circ\text{C} + 333 \text{ W} \times \left[ \frac{1}{25 \times 10^{-3} \text{ m}} - \frac{1}{(25 \times 10^{-3} \text{ m} + 5 \times 10^{-3} \text{ m})} \right] / (4\pi \times 2 \text{ W/m} \cdot \text{K})$$

$$T_{s,1} = 1049.2^\circ\text{C}$$

The maximum temperature occurs at the center of the sphere at the exit plane. Beginning with the heat equation for the pellet, find

$$\frac{d}{dr} \left( r^2 \frac{dT}{dr} \right) = - \frac{\dot{q}}{k} r^2$$

$$r^2 \frac{dT}{dr} = - \frac{\dot{q}}{3k} r^3 + C_1$$

$$T(r) = - \frac{\dot{q}}{6k} r^2 - \frac{C_1}{r} + C_2$$

Applying boundary conditions,

$$\text{at } r = 0, \quad dT/dr|_{r=0} = 0 \rightarrow C_1 = 0$$

$$\text{at } r = r_p = D_p/2, \quad T(r_p) = T_{s,1} \rightarrow C_2 = T_{s,1} + \frac{\dot{q}}{6k} r_p^2$$

$$T(r) = T_{s,1} + \frac{\dot{q}}{6k} (r_p^2 - r^2)$$

$$T(0) = T_{s,1} + \frac{\dot{q} D_p^2}{24k}$$

For  $\dot{q} = \dot{E}_g / \nabla = \dot{E}_g / \left[ \frac{4}{3} \pi (D_p/2)^3 \right]$

$$\dot{q} = 333 \text{ W} / \left[ \frac{4}{3} \times \pi \times (50 \times 10^{-3} \text{ m}/2)^3 \right]$$

$$\dot{q} = 5.09 \times 10^6 \text{ W/m}^3$$

$$T(0) = 1049.2^\circ\text{C} + \frac{5.09 \times 10^6 \text{ W/m}^3 \times (50 \times 10^{-3} \text{ m})^2}{24 \times 2 \text{ W/m} \cdot \text{K}} = 1314^\circ\text{C} \quad <$$

**COMMENTS:** (1) The maximum temperature is below the temperature associated with reduction in the thermal energy generation. (2) Helium is an excellent choice for the working fluid due to its high thermal conductivity and extremely small *nuclear cross section* (Helium does not absorb gamma radiation. Therefore the helium that exists the chamber can be fed directly to a turbine as opposed to transferring thermal energy from the helium to a second working fluid.)

## PROBLEM 7.110

**KNOWN:** Diameter and properties of phase-change material. Dimensions of cylindrical vessel and porosity of packed bed. Inlet temperature and velocity of air.

**FIND:** (a) Outlet temperature of air and rate of melting, (b) Effect of inlet velocity and capsule diameter on outlet temperature, (c) Location at which complete melting of PCM is first to occur and subsequent variation of outlet temperature.

**SCHEMATIC:**

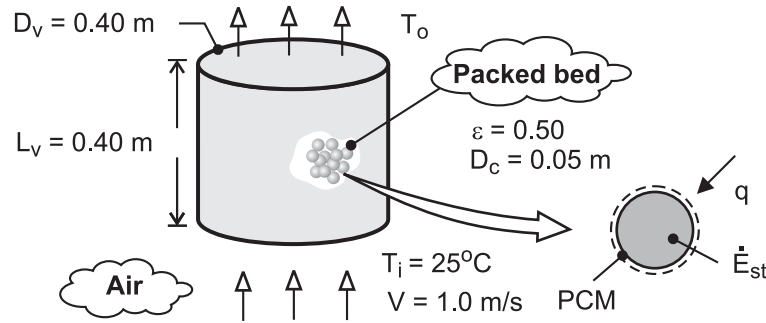

**ASSUMPTIONS:** (1) Negligible thickness (and thermal resistance) of capsule shell, (2) All capsules are at  $T_{mp}$ , (3) Constant properties, (4) Negligible heat transfer from surroundings to vessel.

**PROPERTIES:** Prescribed, PCM:  $T_{mp} = 4^\circ\text{C}$ ,  $\rho = 1200 \text{ kg/m}^3$ ,  $h_{sf} = 165 \text{ kJ/kg}$ . *Table A-4*, Air (Assume  $(T_i + T_o)/2 = 17^\circ\text{C} = 290\text{K}$ ):  $\rho_a = 1.208 \text{ kg/m}^3$ ,  $c_p = 1007 \text{ J/kg}\cdot\text{K}$ ,  $\nu = 15.00 \times 10^{-6} \text{ m}^2/\text{s}$ ,  $\text{Pr} = 0.71$ .

**ANALYSIS:** (a) For a packed bed the outlet temperature is given by

$$T_o = T_{mp} - (T_{mp} - T_i) \exp\left(-\frac{\bar{h} A_{p,t}}{\rho_a V A_{c,b} c_p}\right)$$

where  $A_{c,b} = \pi D_v^2 / 4 = \pi (0.40\text{m})^2 / 4 = 0.126\text{m}^2$  and  $A_{p,t} = (1 - \varepsilon)(\nabla_v / \nabla_c)(\pi D_c^2) = (1 - \varepsilon)(1.5 \pi L_v D_v^2 / D_c) = 0.5(1.5 \pi \times 0.4\text{m}^3 / 0.05\text{m}) = 3.02\text{m}^2$ . With  $\text{Re}_D = VD_c / \nu = 1\text{m/s} \times 0.05\text{m} / 15.00 \times 10^{-6} \text{ m}^2/\text{s} = 3333$ , the convection correlation for a packed bed yields

$$\varepsilon \bar{j}_H = \varepsilon \bar{\text{St}} \text{Pr}^{2/3} = \varepsilon \frac{\bar{h}}{\rho_a V c_p} \text{Pr}^{2/3} = 2.06 \text{Re}_D^{-0.575}$$

$$\bar{h} = \frac{2.06 \rho_a V c_p}{\varepsilon \text{Pr}^{2/3} \text{Re}_D^{0.575}} = \frac{2.06 \times 1.208 \text{ kg/m}^3 \times 1\text{m/s} \times 1007 \text{ J/kg}\cdot\text{K}}{0.5(0.71)^{2/3} (3333)^{0.575}} = 59.4 \text{ W/m}^2 \cdot \text{K}$$

Hence, 
$$T_o = 4^\circ\text{C} + (21^\circ\text{C}) \exp\left(-\frac{59.4 \text{ W/m}^2 \cdot \text{K} \times 3.02\text{m}^2}{1.208 \text{ kg/m}^3 \times 1\text{m/s} \times 0.126\text{m}^2 \times 1007 \text{ J/kg}\cdot\text{K}}\right) = 10.5^\circ\text{C} <$$

The rate at which PCM in the vessel changes from the solid to liquid state,  $\dot{M}$  (kg/s), may be obtained from an energy balance that equates the total rate of heat transfer to the capsules to the rate of increase in latent energy of the PCM. That is

$$q = \frac{d}{dt}(M h_{sf}) = h_{sf} \dot{M}$$

Continued ...



### PROBLEM 7.110 (Cont.)

where  $M$  is the total mass of PCM and

$$q = -\bar{h} A_{p,t} \frac{(T_{mp} - T_i) - (T_{mp} - T_o)}{\ln\left(\frac{T_{mp} - T_i}{T_{mp} - T_o}\right)} = -59.4 \text{ W/m}^2 \cdot \text{K} \times 3.02 \text{ m}^2 \frac{-14.5^\circ\text{C}}{\ln\left(\frac{-21}{-6.5}\right)} = 2220 \text{ W}$$

Hence,  $\dot{M} = q / h_{sf} = 2220 \text{ W} / 165,000 \text{ J/kg} = 0.0134 \text{ kg/s}$  <

(b) The effect of the inlet velocity and capsule diameter are shown below.

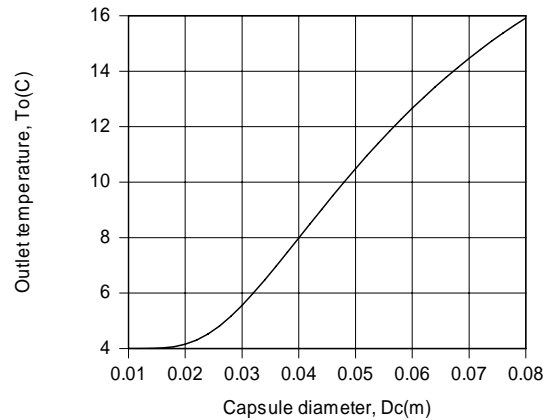
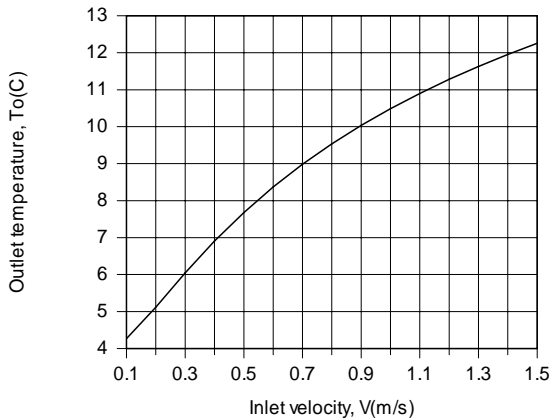

Despite the reduction in  $\bar{h}$  with decreasing  $V$ , the reduction in the mass flow rate of air through the vessel and the corresponding increase in the residence time of air in the vessel allow it to more closely achieve thermal equilibrium with the capsules before it leaves the vessel. Hence,  $T_o$  decreases with decreasing  $V$ , approaching  $T_{mp}$  in the limit  $V \rightarrow 0$ . Of course, the production of chilled air in kg/s decreases accordingly. With decreasing capsule diameter, there is an increase in the number of capsules in the vessel and in the total surface area  $A_{p,t}$  for heat transfer from the air. Hence, the heat rate increases with decreasing  $D_c$  and the outlet temperature of the air decreases.

(c) Because the temperature of the air decreases as it moves through the vessel, heat rates to the capsules are largest and smallest at the entrance and exit, respectively, of the vessel. Hence, complete melting will first occur in capsules at the entrance. After complete melting begins to occur in the capsules, progressing downstream with increasing time, heat transfer from the air will increase the temperatures of the capsules, thereby decreasing the heat rate. With decreasing heat rate, the outlet temperature will increase, approaching the inlet temperature after melting has occurred in all capsules and they achieve thermal equilibrium with the inlet air.

**COMMENTS:** (1) The estimate of  $T_o$  used to evaluate the properties of air was good, and iteration of the solution is not necessary. (2) The total mass of phase change material in the vessel is  $M = N_c$

$$\rho \nabla_c = [(1 - \varepsilon) \nabla_v / \nabla_c] \rho \nabla_c = (1 - \varepsilon) \rho L_v \left( \pi D_v^2 / 4 \right) = (\pi / 4) 0.5 \times 1200 \text{ kg/m}^3 (0.4 \text{ m})^3 = 30.2 \text{ kg.}$$

At the maximum possible melting rate of  $\dot{M} = 0.0134 \text{ kg/s}$ , it would therefore take  $2250 \text{ s} = 37.5 \text{ min}$  to melt all of the PCM in the vessel. Why would it, in fact, take longer to melt all of the PCM?

## PROBLEM 7.111

**KNOWN:** Diameter and properties of phase-change material. Dimensions of cylindrical vessel and porosity of packed bed. Inlet temperature and velocity of air.

**FIND:** (a) Outlet temperature of air and rate of melting for  $\varepsilon = 0.3$  and length reduced to compensate, (b) Outlet temperature of air and rate of melting for  $\varepsilon = 0.3$  and diameter reduced to compensate. Which geometry is preferred.

**SCHEMATIC:**

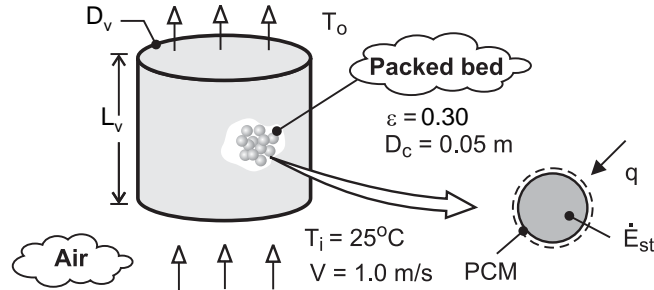

**ASSUMPTIONS:** (1) Negligible thickness (and thermal resistance) of capsule shell, (2) All capsules are at  $T_{mp}$ , (3) Constant properties, (4) Negligible heat transfer from surroundings to vessel.

**PROPERTIES:** Prescribed, PCM:  $T_{mp} = 4^\circ\text{C}$ ,  $\rho = 1200 \text{ kg/m}^3$ ,  $h_{sf} = 165 \text{ kJ/kg}$ . *Table A-4*, Air (Assume  $(T_i + T_o)/2 = 17^\circ\text{C} = 290\text{K}$ ):  $\rho_a = 1.208 \text{ kg/m}^3$ ,  $c_p = 1007 \text{ J/kg}\cdot\text{K}$ ,  $\nu = 15.00 \times 10^{-6} \text{ m}^2/\text{s}$ ,  $Pr = 0.71$ .

**ANALYSIS:** (a) The new length of the vessel is determined from the fact that the same mass, or volume, of capsules is now compressed to give a porosity of 0.3 instead of 0.5. We can relate the total capsule volume,  $\forall_c$ , to the vessel volume,  $\forall_v = \pi D_v^2 L_v$ , as follows.

$$\forall_c = (1 - \varepsilon_{old}) \forall_{v,old} = (1 - \varepsilon_{new}) \forall_{v,new} \quad (1)$$

Thus,

$$L_{v,new} = \frac{(1 - \varepsilon_{old})}{(1 - \varepsilon_{new})} L_{v,old} = \frac{0.5}{0.7} 0.4 \text{ m} = 0.286 \text{ m}$$

For a packed bed the outlet temperature is given by

$$T_o = T_{mp} - (T_{mp} - T_i) \exp\left(-\frac{\bar{h} A_{p,t}}{\rho_a \forall A_{c,b} c_p}\right) \quad (2)$$

where  $A_{c,b} = \pi D_v^2 / 4 = \pi (0.40 \text{ m})^2 / 4 = 0.126 \text{ m}^2$  and  $A_{p,t} = (1 - \varepsilon)(\forall_v / \forall_c)(\pi D_c^2) = (1 - \varepsilon)(1.5 \pi L_v D_v^2 / D_c) = 0.7(1.5 \pi \times 0.286 \text{ m} \times 0.4^2 \text{ m}^2 / 0.05 \text{ m}) = 3.02 \text{ m}^2$ . With  $Re_D = VD_c / \nu = 1 \text{ m/s} \times 0.05 \text{ m} / 15.00 \times 10^{-6} \text{ m}^2/\text{s} = 3333$ , the convection correlation for a packed bed yields

Continued ...

**PROBLEM 7.111 (Cont.)**

$$\varepsilon \bar{j}_H = \varepsilon \bar{St} Pr^{2/3} = \varepsilon \frac{\bar{h}}{\rho_a V c_p} Pr^{2/3} = 2.06 Re_D^{-0.575}$$

$$\bar{h} = \frac{2.06 \rho_a V c_p}{\varepsilon Pr^{2/3} Re_D^{0.575}} = \frac{2.06 \times 1.208 \text{ kg/m}^3 \times 1 \text{ m/s} \times 1007 \text{ J/kg} \cdot \text{K}}{0.3(0.71)^{2/3} (3333)^{0.575}} = 99.0 \text{ W/m}^2 \cdot \text{K}$$

Hence,  $T_o = 4^\circ\text{C} + (21^\circ\text{C}) \exp\left(-\frac{99.0 \text{ W/m}^2 \cdot \text{K} \times 3.02 \text{ m}^2}{1.208 \text{ kg/m}^3 \times 1 \text{ m/s} \times 0.126 \text{ m}^2 \times 1007 \text{ J/kg} \cdot \text{K}}\right) = 7.0^\circ\text{C} <$

The rate at which PCM in the vessel changes from the solid to liquid state,  $\dot{M}$  (kg/s), may be obtained from an energy balance that equates the total rate of heat transfer to the capsules to the rate of increase in latent energy of the PCM. That is

$$q = \frac{d}{dt}(M h_{sf}) = h_{sf} \dot{M}$$

where  $M$  is the total mass of PCM and

$$q = -\bar{h} A_{p,t} \frac{(T_{mp} - T_i) - (T_{mp} - T_o)}{\ln\left(\frac{T_{mp} - T_i}{T_{mp} - T_o}\right)} = -99.0 \text{ W/m}^2 \cdot \text{K} \times 3.02 \text{ m}^2 \frac{-18^\circ\text{C}}{\ln\left(\frac{-21}{-3.0}\right)} = 2770 \text{ W}$$

Hence,  $\dot{M} = q / h_{sf} = 2770 \text{ W} / 165,000 \text{ J/kg} = 0.0168 \text{ kg/s} <$

(b) The new vessel diameter is found from Eq. (1) to be

$$D_{v,new} = \sqrt{\frac{(1 - \varepsilon_{old})}{(1 - \varepsilon_{new})}} D_{v,old} = \sqrt{\frac{0.5}{0.7}} 0.4 \text{ m} = 0.338 \text{ m}$$

Since the mass flow rate of air is unchanged, the velocity must be increased to compensate for the reduced diameter, thus

$$V_{new} = V_{old} D_{v,old}^2 / D_{v,new}^2 = 1 \text{ m/s} (0.4 \text{ m} / 0.338 \text{ m})^2 = 1.40 \text{ m/s}$$

Repeating all of the calculations, we find

$$A_{c,b} = \pi D_v^2 / 4 = \pi (0.338 \text{ m})^2 / 4 = 0.0897 \text{ m}^2, \quad A_{p,t} = 3.02 \text{ m}^2 \text{ (unchanged)}, \quad Re_D = 4667,$$

$$\bar{h} = 114 \text{ W/m}^2 \cdot \text{K}, \text{ and}$$

$$T_o = 6.2^\circ\text{C} <$$

Continued ...

### PROBLEM 7.111 (Cont.)

Then  $q = 2870 \text{ W}$  and

$$\dot{M} = 0.0173 \text{ kg/s} \quad <$$

This configuration results in a lower air outlet temperature and an increased PCM melting rate. <

**COMMENTS:** (1) The estimate of  $T_o$  used to evaluate the properties of air was reasonably good, and iteration of the solution is not necessary. (2) Compared to Problem 7.110 which had  $\varepsilon = 0.5$ , both of these configurations yield a higher heat transfer coefficient and result in a lower outlet temperature and are therefore preferable from the heat transfer point-of-view. However, a more thorough design would also consider the pressure drop and pumping power requirements for the various configurations. Which configuration do you expect to have the lowest pumping power requirement? (3) By reducing the vessel diameter in part (b), the velocity and Reynolds number increase, thereby increasing the heat transfer coefficient. This yields a lower outlet temperature compared to part (a).

## PROBLEM 7.112

**KNOWN:** Diameter and properties of phase-change material. Dimensions of cylindrical vessel and porosity of packed bed. Inlet temperature and velocity of air.

**FIND:** (a) Outlet temperature of air and rate of freezing, (b) Effect of inlet velocity and capsule diameter on outlet temperature, (c) Location at which complete melting of PCM is first to occur and subsequent variation of outlet temperature.

**SCHEMATIC:**

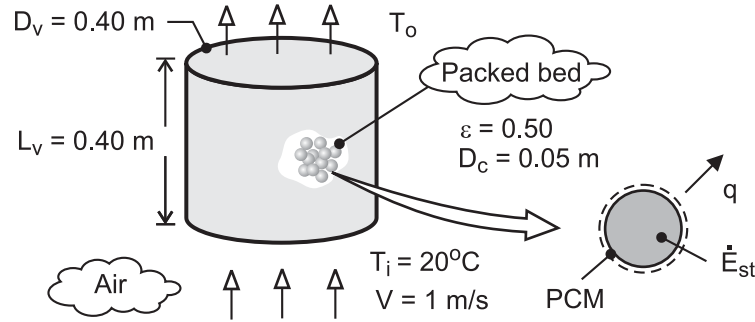

**ASSUMPTIONS:** (1) Negligible thickness (and thermal resistance) of capsule shell, (2) All capsules are at  $T_{mp}$ , (3) Constant properties, (4) Negligible heat transfer from vessel to surroundings.

**PROPERTIES:** Prescribed, PCM:  $T_{mp} = 50^\circ\text{C}$ ,  $\rho = 900 \text{ kg/m}^3$ ,  $h_{sf} = 200 \text{ kJ/kg}$ . *Table A-4*, Air (Assume  $(T_i + T_o)/2 = 30^\circ\text{C} = 303\text{K}$ ):  $\rho_a = 1.151 \text{ kg/m}^3$ ,  $c_p = 1007 \text{ J/kg}\cdot\text{K}$ ,  $\nu = 16.2 \times 10^{-6} \text{ m}^2/\text{s}$ ,  $\text{Pr} = 0.707$ .

**ANALYSIS:** (a) For a packed bed the outlet temperature is given by

$$T_o = T_{mp} - (T_{mp} - T_i) \exp\left(-\frac{\bar{h} A_{p,t}}{\rho_a V A_{c,b} c_p}\right)$$

where  $A_{c,b} = \pi D_v^2 / 4 = 0.126 \text{ m}^2$  and  $A_{p,t} = (1 - \varepsilon)(\nabla_v / \nabla_c) \pi D_c^2 = 3.02 \text{ m}^2$ . With  $\text{Re}_D = VD_c / \nu = 3086$ , the convection correlation for a packed bed yields

$$\varepsilon \bar{h} = \varepsilon \bar{\text{St}} \text{Pr}^{2/3} = \varepsilon \frac{\bar{h}}{\rho_a V c_p} \text{Pr}^{2/3} = 2.06 \text{Re}_D^{-0.575}$$

$$\bar{h} = \frac{2.06 \rho_a V c_p}{\varepsilon \text{Pr}^{2/3} \text{Re}_D^{0.575}} = \frac{2.06 \times 1.151 \text{ kg/m}^3 \times 1 \text{ m/s} \times 1007 \text{ J/kg}\cdot\text{K}}{0.5 (0.707)^{2/3} (3086)^{0.575}} = 59.1 \text{ W/m}^2 \cdot \text{K}$$

Hence,

$$T_o = 50^\circ\text{C} - (30^\circ\text{C}) \exp\left(-\frac{59.1 \text{ W/m}^2 \cdot \text{K} \times 3.02 \text{ m}^2}{1.151 \text{ kg/m}^3 \times 1 \text{ m/s} \times 0.126 \text{ m}^2 \times 1007 \text{ J/kg}\cdot\text{K}}\right) = 41.2^\circ\text{C} <$$

The rate at which PCM in the vessel solidifies,  $\dot{M}$  (kg/s), may be obtained from an energy balance that equates the total rate of heat transfer from the capsules to the rate at which the latent energy of the PCM decreases. That is,

$$q = \frac{d}{dt}(M h_{s,f}) = h_{sf} \dot{M}$$

where  $M$  is the total mass of PCM and

Continued ...

**PROBLEM 7.112 (Cont.)**

$$q = \bar{h} A_{p,t} \frac{(T_{mp} - T_i) - (T_{mp} - T_o)}{\ln\left(\frac{T_{mp} - T_i}{T_{mp} - T_o}\right)} = 59.1 \text{ W/m}^2 \cdot \text{K} \times 3.02 \text{ m}^2 \frac{21.2^\circ\text{C}}{\ln\left(\frac{30}{8.8}\right)} = 3085 \text{ W}$$

Hence,  $\dot{M} = q / h_{sf} = 3085 \text{ W} / 200,000 \text{ J/kg} = 0.0154 \text{ kg/s}$

<

(b) The effect of  $V$  and  $D_c$  are shown below

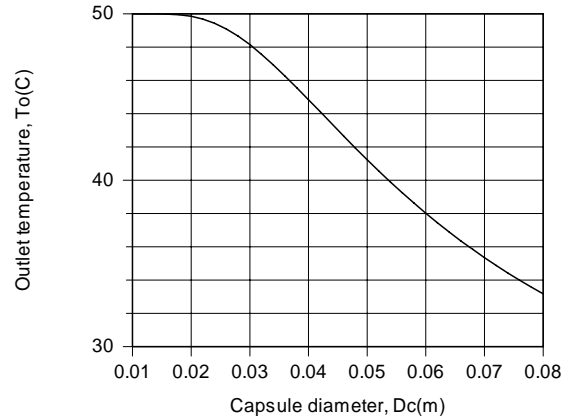
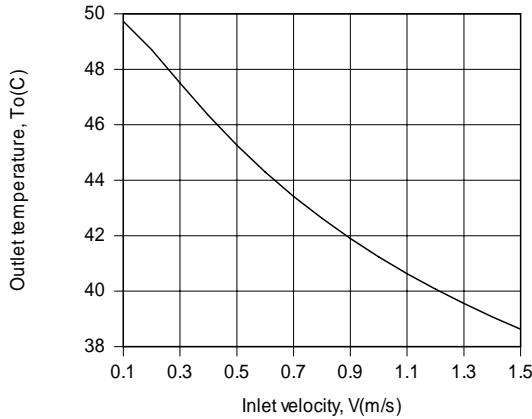

Despite the reduction in  $\bar{h}$  with decreasing  $V$ , the reduction in the mass flow rate of air in the vessel and the corresponding increase in the residence time of air in the vessel allow it to more closely reach thermal equilibrium with the capsules before it leaves the vessel. Hence,  $T_o$  increases with decreasing  $V$ , approaching  $T_{mp}$  in the limit  $V \rightarrow 0$ . Of course, the production of warm air in kg/s decreases accordingly. With decreasing capsule diameter, there is an increase in the number of capsules in the vessel and in the total surface area  $A_{p,t}$  for heat transfer to the air. Hence, the heat rate and the air outlet temperature increase with decreasing  $D_c$ .

(c) Because the air temperature increases as it moves through the vessel, heat rates from the capsules are largest and smallest at the entrance and exit, respectively, of the vessel. Hence, complete freezing will first occur in capsules at the entrance. After complete freezing begins to occur in the capsules, progressing downstream with increasing time, heat transfer to the air will decrease the temperatures of the capsules, thereby decreasing the heat rate. With decreasing heat rate, the outlet temperature will decrease, approaching the inlet temperature after freezing has occurred in all capsules and they achieve thermal equilibrium with the inlet air.

**COMMENTS:** (1) The estimate of  $T_o$  used to evaluate the properties of air was good, and iteration of the solution is not necessary. (2) The total mass of phase change material in the vessel is  $M = N_c \rho \forall_c = [(1 - \varepsilon) \forall_v / \forall_c] \rho \forall_c = (1 - \varepsilon) \rho L_v \left( \pi D_v^2 / 4 \right) = 22.6 \text{ kg}$ . At the maximum possible melting rate of  $\dot{M} = 0.0154 \text{ kg/s}$ , it would therefore take  $1470 \text{ s} = 24.5 \text{ min}$  to freeze all of the PCM in the vessel. Why would it, in fact, take longer to freeze all of the PCM?

### PROBLEM 7.113

**KNOWN:** Dimensions, particle diameter, and porosity of bronze foam sheet. Temperature of upper and lower surfaces of foam. Velocity and inlet temperature of air flowing through foam.

**FIND:** (a) Convection heat transfer rate to air assuming foam is at uniform temperature  $T_s$ . Whether actual heat transfer rate would be greater, less, or the same. (b) Convection heat transfer rate to air treating foam as an extended surface with one-dimensional conduction in the  $x$ -direction. Whether actual heat transfer rate would be greater, less, or the same. Effective perimeter and effective thermal conductivity of the foam.

**SCHEMATIC:**

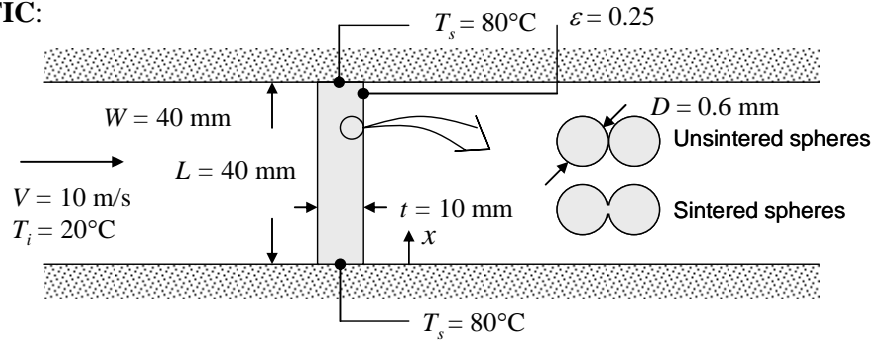

**ASSUMPTIONS:** (1) Steady-state conditions, (2) One-dimensional heat transfer, (3) Constant properties, (4) Foam behaves as packed bed in part (a), (5) Foam behaves as extended surface in part (b), (6) Negligible radiation transfer.

**PROPERTIES:** Table A-1, Commercial bronze ( $T \approx 325$  K):  $k_b = 52$  W/m·K. Table A-4, Air ( $T \approx 325$  K):  $\rho = 1.0782$  kg/m<sup>3</sup>,  $c_p = 1008$  J/kg·K,  $k = 0.0282$  W/m·K,  $\nu = 18.41 \times 10^{-6}$  m<sup>2</sup>/s,  $Pr = 0.704$ .

**ANALYSIS:** (a) The heat transfer coefficient can be found from Equation 7.81:

$$\varepsilon \bar{j}_H = \varepsilon \frac{\bar{h}}{\rho c_p V} Pr^{2/3} = 2.06 Re_D^{-0.575}$$

where  $Re_D = VD/\nu = 10 \text{ m/s} \times 0.0006 \text{ m} / 18.41 \times 10^{-6} \text{ m}^2/\text{s} = 326$

$$\begin{aligned} \bar{h} &= \frac{2.06 \rho c_p V}{\varepsilon} Re_D^{-0.575} Pr^{-2/3} \\ &= \frac{2.06 \times 1.0782 \text{ kg/m}^3 \times 1008 \text{ J/kg} \cdot \text{K} \times 10 \text{ m/s}}{0.25} (326)^{-0.575} (0.704)^{-2/3} = 4060 \text{ W/m}^2 \cdot \text{K} \end{aligned}$$

The surface area can be found as follows, where  $N$  = number of particles:

$$\begin{aligned} V_p &= N\pi D^3/6 = (1 - \varepsilon)V_{\text{tot}} = (1 - \varepsilon)WtL \text{ and} \\ A_{p,t} &= N\pi D^2 = 6(1 - \varepsilon)WtL/D = \frac{6 \times 0.75 \times 0.04 \text{ m} \times 0.01 \text{ m} \times 0.04 \text{ m}}{0.0006 \text{ m}} = 0.12 \text{ m}^2 \end{aligned}$$

The outlet air temperature is given by Equation 7.83:

$$T_o = T_s - (T_s - T_i) \exp\left(\frac{-\bar{h}A_{p,t}}{\rho V A_{c,b} c_p}\right)$$

Continued...

**PROBLEM 7.113 (Cont.)**

$$= 80^{\circ}\text{C} - 60^{\circ}\text{C} \exp\left(\frac{-4060 \text{ W/m}^2 \cdot \text{K} \times 0.12 \text{ m}^2}{1.0782 \text{ kg/m}^3 \times 10 \text{ m/s} \times (0.04 \text{ m})^2 \times 1008 \text{ J/kg} \cdot \text{K}}\right) = 80^{\circ}\text{C}$$

From Equation 7.82, or equivalently from an energy balance on the air,

$$q = \dot{m}c_p(T_o - T_i) = \rho VA_{c,b}c_p(T_o - T_i) \\ = 1.0782 \text{ kg/m}^3 \times 10 \text{ m/s} \times (0.04 \text{ m})^2 \times 1008 \text{ J/kg} \cdot \text{K} \times (80 - 20)^{\circ}\text{C} = 1043 \text{ W} \quad <$$

We would expect the actual convection heat transfer rate to be less because the foam has a conduction resistance and there are temperature gradients in the foam, primarily in the  $x$ -direction. Thus, near the center of the cross-section, the foam temperature will be reduced and so will the heat transfer rate.

(b) For a slice of the foam of length  $dx$ , the surface area of foam in contact with the air is  $dA_s = A_{p,t}dx/L$ . Thus,

$$dq_{\text{conv}} = \frac{\bar{h}A_{p,t}dx}{L}(T(x) - T_{\infty})$$

By analogy with  $dq_{\text{conv}} = hPdx(T(x) - T_{\infty})$  for a solid fin, we find

$$P_{\text{eff}} = \frac{A_{p,t}}{L} = \frac{0.12 \text{ m}^2}{0.04 \text{ m}} = 3.0 \text{ m} \quad <$$

From Equation 3.25 with  $k_s = k_b$ ,

$$k_{\text{eff}} = \left[ \frac{k_f + 2k_b - 2\varepsilon(k_b - k_f)}{k_f + 2k_b + \varepsilon(k_b - k_f)} \right] k_b \\ = \left[ \frac{(0.0282 + 2 \times 52 - 2 \times 0.25 \times (52 - 0.0282)) \text{ W/m} \cdot \text{K}}{(0.0282 + 2 \times 52 + 0.25 \times (52 - 0.0282)) \text{ W/m} \cdot \text{K}} \right] \times 52 \text{ W/m} \cdot \text{K} = 34.7 \text{ W/m} \cdot \text{K} \quad <$$

Due to symmetry, the foam sheet can be treated as a fin of length  $L/2$  with an insulated fin tip. From Equation 3.81,

$$q_f = 2\sqrt{\bar{h}P_{\text{eff}}k_{\text{eff}}A_{c,f}}(T_s - T_i) \tanh(mL/2)$$

where the factor of 2 accounts for both halves of the foam, each of length  $L/2$ ,  $A_{c,f}$  is the fin cross-sectional area,  $A_{c,f} = Wt = 0.04 \text{ m} \times 0.01 \text{ m} = 4 \times 10^{-4} \text{ m}^2$ , and

$$m = \sqrt{\bar{h}P_{\text{eff}}/k_{\text{eff}}A_{c,f}} = \sqrt{4060 \text{ W/m}^2 \cdot \text{K} \times 3 \text{ m}/(34.7 \text{ W/m} \cdot \text{K} \times 4 \times 10^{-4} \text{ m}^2)} = 937 \text{ m}^{-1}$$

Continued...



### PROBLEM 7.113 (Cont.)

Thus,

$$\begin{aligned}q_f &= 2\sqrt{4060 \text{ W/m}^2 \cdot \text{K} \times 3 \text{ m} \times 34.7 \text{ W/m} \cdot \text{K} \times 4 \times 10^{-4} \text{ m}^2 (80 - 20)^\circ\text{C} \tanh(933 \text{ m}^{-1} \times 0.02 \text{ m})} \\ &= 1560 \text{ W} \end{aligned} \quad <$$

We would expect the actual rate of heat transfer to be less because the air temperature increases as it flows through the foam. This is not accounted for in the extended surface analysis, and if it were to be accounted for, we would have a smaller driving overall temperature difference through most of the foam, reducing  $q_f$ . <

**COMMENTS:** (1) The results *suggest* that the foam might be an effective heat transfer medium. The heat transfer rates are quite high. However, the actual heat transfer rate will be lower than calculated here because of the *simultaneous* conduction resistance in the foam *and* increase in the air temperature as it passes through the foam. (2) In Problem 11.93, this problem is solved accounting for both the variation of air temperature in the flow direction and the variation of foam temperature in the  $x$ -direction. By accounting for both effects, you will learn that the heat transfer rates calculated here significantly overestimate the actual heat transfer rate.

### PROBLEM 7.114

**KNOWN:** Flow of air over a flat, smooth wet plate.

**FIND:** (a) Average mass transfer coefficient,  $\bar{h}_m$ , (b) Water vapor mass loss rate,  $n_A$  (kg/s).

**SCHEMATIC:**

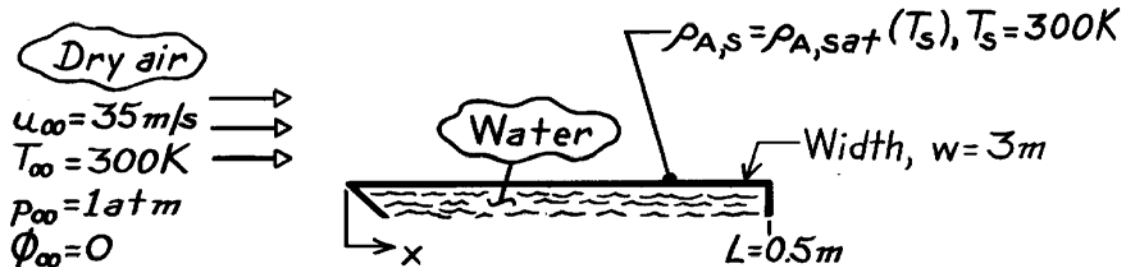

**ASSUMPTIONS:** (1) Steady-state conditions, (2) Heat-mass transfer analogy applies, (3)  $Re_{x,c} = 5 \times 10^5$ .

**PROPERTIES:** Table A-4, Air (300K):  $\nu = 15.89 \times 10^{-6}\text{ m}^2/\text{s}$ ,  $Pr = 0.707$ ; Table A-8, Water vapor-air (300K, 1 atm):  $D_{AB} = 0.26 \times 10^{-4}\text{ m}^2/\text{s}$ ,  $Sc = \nu/D_{AB} = 0.611$ ; Table A-6, Water vapor (300K):  $\rho_{A,sat} = 1/v_g = 0.0256\text{ kg/m}^3$ .

**ANALYSIS:** (a) The Reynolds number for the plate,  $x = L$ , is

$$Re_L = \frac{u_\infty L}{\nu} = \frac{35\text{ m/s} \times 0.5\text{ m}}{15.89 \times 10^{-6}\text{ m}^2/\text{s}} = 1.10 \times 10^6.$$

Hence flow is mixed and the appropriate flat plate convection correlation is given by Eq. 7.41,

$$\overline{Sh}_L = \frac{\bar{h}_m L}{D_{AB}} = (0.037 Re_L^{4/5} - 871) Sc^{1/3} = \left( 0.037 [1.10 \times 10^6]^{0.8} - 871 \right) 0.611^{0.33}$$

giving

$$\overline{Sh}_L = 1399 \quad \bar{h}_m = \frac{1399 \times 0.26 \times 10^{-4}\text{ m}^2/\text{s}}{0.5\text{ m}} = 0.0728\text{ m/s}. \quad <$$

(b) The evaporative mass loss rate is

$$n_A = \bar{h}_m A_s (\rho_{A,s} - \rho_{A,\infty})$$

where  $A_s = L \cdot w$ ,  $\rho_{A,\infty} = 0$  (dry air) and  $\rho_{A,s} = \rho_{A,sat}$ . Hence,

$$n_A = 0.0728\text{ m/s} \times (0.5 \times 3)\text{ m}^2 (0.0256 - 0)\text{ kg/m}^3 = 0.0028\text{ kg/s}. \quad <$$

## PROBLEM 7.115

**KNOWN:** Air flow conditions over a wetted flat plate of known length and temperature.

**FIND:** (a) Heat loss and evaporation rate, per unit plate width,  $q'$  and  $n'_A$ , respectively, (b) Compute and plot  $q'$  and  $n'_A$  for a range of water temperatures  $300 \leq T_s \leq 350$  K with air velocities of 10, 20 and 35 m/s, and (c) Water temperature  $T_s$  at which the heat loss will be zero for the air velocities and temperatures of part (b).

**SCHEMATIC:**

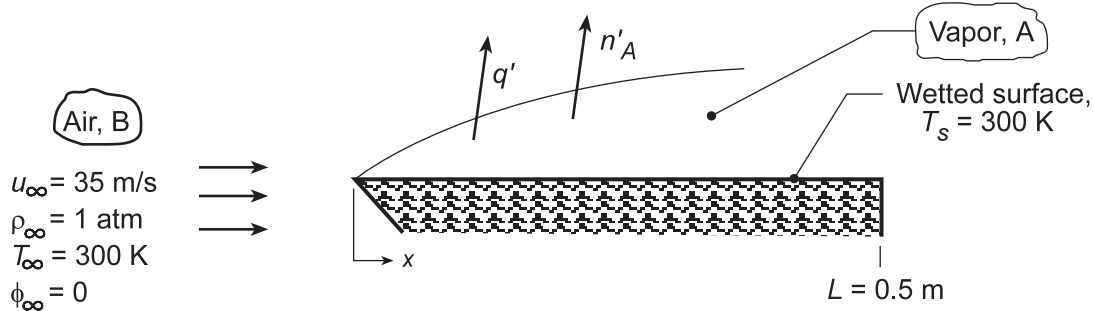

**ASSUMPTIONS:** (1) Heat and mass transfer analogy is applicable, (2) Constant properties, (3)  $Re_{x,c} = 5 \times 10^5$ .

**PROPERTIES:** Table A.4, Air ( $T = 300$  K, 1 atm):  $\nu = 15.89 \times 10^{-6} \text{ m}^2/\text{s}$ ; Table A.6, Water (300 K):  $v_g = 39.13 \text{ m}^3/\text{kg}$ ,  $h_{fg} = 2438 \text{ kJ/kg}$ ; Table A.8, Water-air (298 K, 1 atm):  $D_{AB} = 0.26 \times 10^{-4} \text{ m}^2/\text{s}$ ,  $Sc = 0.61$ .

**ANALYSIS:** (a) The heat loss from the plate is due only to the transfer of latent heat. Per unit width of the plate,

$$q' = n'_A h_{fg} \quad (1)$$

$$n'_A = \bar{h}_m L [\rho_{A,\text{sat}}(T_s) - \rho_{A,\infty}] = \bar{h}_m L \rho_{A,\text{sat}}(T_s) \quad (2)$$

With

$$Re_L = \frac{u_\infty L}{\nu} = \frac{35 \text{ m/s} \times 0.5 \text{ m}}{15.89 \times 10^{-6} \text{ m}^2/\text{s}} = 1.10 \times 10^6$$

mixed boundary layer condition exists and the appropriate correlation is Eq. 7.41 with  $A = 871$ ,

$$\bar{Sh}_L = (0.037 Re_L^{4/5} - 871) Sc^{1/3} = \left[ 0.037 (1.10 \times 10^6)^{4/5} - 871 \right] (0.61)^{1/3} \quad (3)$$

giving  $\bar{Sh}_L = 1398$  and

$$\bar{h}_m = \bar{Sh}_L \frac{D_{AB}}{L} = 1398 \frac{0.26 \times 10^{-4} \text{ m}^2/\text{s}}{0.5 \text{ m}} = 0.0727 \text{ m/s}.$$

with  $\rho_{A,\text{sat}}(T_s) = v_g^{-1} = 0.0256 \text{ kg/m}^3$ ,

$$n'_A = 0.0727 \text{ m/s} (0.5 \text{ m}) (0.0256 \text{ kg/m}^3) = 9.29 \times 10^{-4} \text{ kg/s} \cdot \text{m} \quad <$$

Hence, the evaporative heat loss per unit plate width is

$$q' = n'_A h_{fg} = 9.29 \times 10^{-4} \text{ kg/s} \cdot \text{m} (2.438 \times 10^6 \text{ J/kg}) = 2265 \text{ W/m} \quad <$$

Continued...

### PROBLEM 7.115 (Cont.)

Heat would have to be applied to the plate in the amount of 2265 W/m to maintain its temperature at 300 K with the evaporative heat loss.

(b) When  $T_s$  and  $T_\infty$  are different, convection heat transfer will also occur, and the heat loss from the water surface is

$$q'_{\text{loss}} = q'_{\text{conv}} + q'_{\text{evap}} = \bar{h}L(T_s - T_\infty) + n'_A h_{fg} \quad (4)$$

Invoking the heat-mass analogy, Eq. 6.60 with  $n = 1/3$ ,

$$\bar{h}/\bar{h}_m = \rho c (\alpha/D_{AB})^{2/3} \quad (5)$$

where  $\bar{h}_m$  and  $n'_A$  are evaluated using Eqs. (3) and (2), respectively. Using the foregoing relations in the *IHT Workspace*, but evaluating  $\bar{h}$  (rather than  $\bar{h}_m$ ) with the *Correlations Tool, External Flow*, for the *Average coefficient for Laminar or Mixed Flow*,  $q'_{\text{loss}}$  was evaluated as a function of  $u_\infty$  with  $T_\infty = 300$  K.

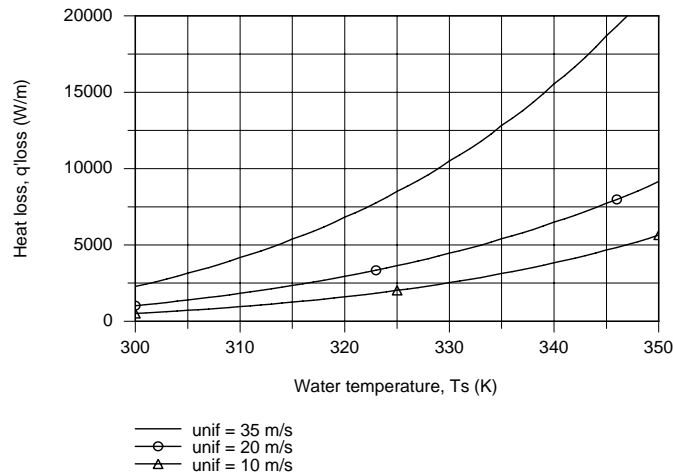

(c) To determine the water temperature  $T_s$  at which the heat loss is zero, the foregoing IHT model was run with  $q'_{\text{loss}} = 0$  with the result that, for all velocities,

$$T_s = 281 \text{ K}$$

<

**COMMENTS:** Why is the result for part (c) independent of the air velocity?

## PROBLEM 7.116

**KNOWN:** Flow over a heated flat plate coated with a volatile substance.

**FIND:** Electric power required to maintain surface at  $T_s = 134^\circ\text{C}$ .

**SCHEMATIC:**

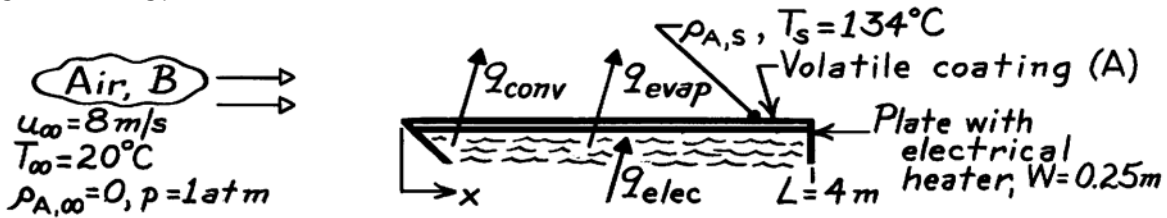

**ASSUMPTIONS:** (1) Steady-state conditions, (2) Heat-mass transfer analogy is applicable, (3) Transition occurs at  $Re_{xc} = 5 \times 10^5$ , (4) Perfect gas behavior of vapor A, (5) Upstream air is dry,  $\rho_{A,\infty} = 0$ .

**PROPERTIES:** Table A-4, Air ( $T_f = (134 + 20)^\circ\text{C}/2 = 350\text{ K}$ , 1 atm):  $\nu = 20.92 \times 10^{-6}\text{ m}^2/\text{s}$ ,  $k = 0.030\text{ W/m}\cdot\text{K}$ ,  $Pr = 0.700$ ; Substance A (given):  $M_A = 150\text{ kg/kmol}$ ,  $p_{A,\text{sat}}(134^\circ\text{C}) = 0.12\text{ atm}$ ,  $D_{AB} = 7.75 \times 10^{-7}\text{ m}^2/\text{s}$ ,  $h_{fg} = 5.44 \times 10^6\text{ J/kg}$ .

**ANALYSIS:** From an overall energy balance on the plate, the power required to maintain  $T_s$  is

$$q_{\text{elec}} = q_{\text{conv}} + q_{\text{evap}} = \bar{h}_L A_s (T_s - T_\infty) + \bar{h}_{m,L} A_s (\rho_{A,s} - \rho_{A,\infty}) h_{fg}. \quad (1)$$

To estimate  $\bar{h}_L$ , first determine  $Re_L$ ,

$$Re_L = u_\infty L / \nu = 8\text{ m/s} \times 4\text{ m} / 20.92 \times 10^{-6}\text{ m}^2/\text{s} = 1.530 \times 10^6.$$

Hence the flow is mixed and the appropriate correlation:

$$\bar{Nu}_L = \bar{h}_L L / k = \left( 0.037 Re_L^{4/5} - 871 \right) Pr^{1/3}$$

$$\bar{h}_L = (0.030\text{ W/m}\cdot\text{K}/4\text{ m}) \left( 0.037 (1.530 \times 10^6)^{4/5} - 871 \right) (0.700)^{1/3} = 16.0\text{ W/m}^2 \cdot \text{K}.$$

To estimate  $\bar{h}_{m,L}$ , invoke the heat-mass analogy, with  $Sc = \nu_B / D_{AB}$ ,

$$\bar{h}_{m,L} = \bar{h}_L \frac{D_{AB}}{k} \left( \frac{Sc}{Pr} \right)^{1/3} = 16.0 \frac{\text{W}}{\text{m}^2 \cdot \text{K}} \left( \frac{7.75 \times 10^{-7}\text{ m}^2/\text{s}}{0.030\text{ W/m}\cdot\text{K}} \right) \left( \frac{20.92 \times 10^{-6}\text{ m}^2/\text{s}}{7.75 \times 10^{-7}\text{ m}^2/\text{s}} / 0.700 \right)^{1/3} = 0.00140 \frac{\text{m}}{\text{s}}.$$

The density of species A at the surface,  $\rho_{A,s}(T_s)$ , follows from the perfect gas law,

$$\rho_{A,s} = p_{A,s} / \frac{\mathcal{R}}{M_A} T_s = 0.12\text{ atm} / \frac{8.205 \times 10^{-2}\text{ m}^3 \cdot \text{atm/kmol} \cdot \text{K}}{150\text{ kg/kmol}} \cdot (134 + 273)\text{ K} = 0.539 \frac{\text{kg}}{\text{m}^3}.$$

Using values calculated for  $\bar{h}_L$ ,  $\bar{h}_{m,L}$  and  $\rho_{A,s}$  in Eq. (1), find

$$q_{\text{elec}} = (4\text{ m} \times 0.25\text{ m}) \left[ 16.0 \frac{\text{W}}{\text{m}^2 \cdot \text{K}} (134 - 20)^\circ\text{C} + 0.00140 \frac{\text{m}}{\text{s}} (0.539 - 0) \frac{\text{kg}}{\text{m}^3} \times 5.44 \times 10^6 \frac{\text{J}}{\text{kg}} \right]$$

$$q_{\text{elec}} = 1.0\text{ m}^2 [1,824 + 4,105]\text{ W/m}^2 = 5.93\text{ kW}. \quad <$$

**COMMENTS:** For these conditions, nearly 70% of the heat loss is by evaporation.

## PROBLEM 7.117

**KNOWN:** Flow of dry air over a water-saturated plate for prescribed flow conditions and mixed temperature.

**FIND:** (a) Mass rate of evaporation per unit plate width,  $n'_A$  ( $\text{kg}/\text{s} \cdot \text{m}$ ), and (b) Calculate and plot  $n'_A$  as a function of velocity for the range  $1 \leq u_\infty \leq 25$  m/s for air and water temperatures of  $T_s = T_\infty = 300$ , 325, and 350 K.

**SCHEMATIC:**

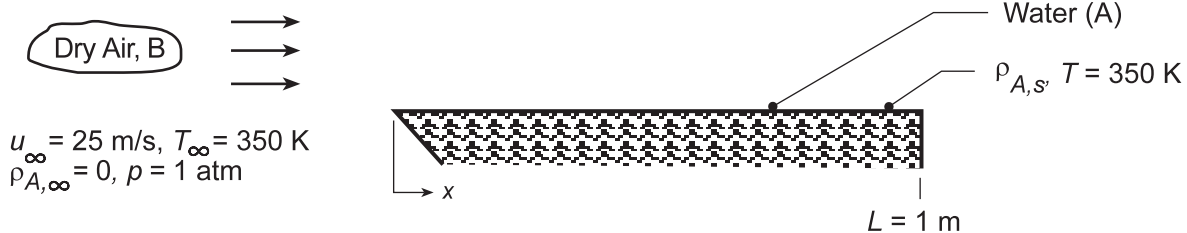

**ASSUMPTIONS:** (1) Water surface is smooth, (2) Heat and mass transfer analogy is applicable, (3)  $Re_{x,c} = 5 \times 10^5$ .

**PROPERTIES:** Table A.6, Water vapor ( $T_s = 350 \text{ K}, 1 \text{ atm}$ ):  $\rho_{A,s} = 1/v_g = 1/3.846 \text{ m}^3/\text{kg} = 0.2600 \text{ kg}/\text{m}^3$ ; Table A.4, Air ( $T_f = T_\infty = 350 \text{ K}, 1 \text{ atm}$ ):  $\nu = 20.92 \times 10^{-6} \text{ m}^2/\text{s}$ ,  $\alpha = 29.9 \times 10^{-6} \text{ m}^2/\text{s}$ ; Table A.8, Air-water ( $T_f = T_\infty = 350 \text{ K}, 1 \text{ atm}$ ):  $D_{AB} = 0.26 \times 10^{-4} \text{ m}^2/\text{s}$  ( $350 \text{ K}/298 \text{ K}$ )<sup>3/2</sup> =  $0.331 \times 10^{-4} \text{ m}^2/\text{s}$ .

**ANALYSIS:** (a) Determine the nature of the air flow by calculating  $Re_L$ . With  $L = 1 \text{ m}$ ,

$$Re_L = \frac{u_\infty L}{\nu} = \frac{25 \text{ m/s} \times 1 \text{ m}}{20.92 \times 10^{-6} \text{ m}^2/\text{s}} = 1.195 \times 10^6. \quad (1)$$

Since  $Re_L > 5 \times 10^5$ , it follows that the flow is mixed, and with Eq. 7.41 with  $A = 871$ , using  $Sc = \nu/D_{AB}$ ,

$$\overline{Sh}_L = \frac{\bar{h}_m L}{D_{AB}} = \left( 0.037 Re_L^{4/5} - 871 \right) Sc^{1/3}. \quad (2)$$

$$\overline{Sh}_L = \left( 0.037 \left[ 1.195 \times 10^6 \right]^{4/5} - 871 \right) \left( \frac{20.92 \times 10^{-6} \text{ m}^2/\text{s}}{0.331 \times 10^{-4} \text{ m}^2/\text{s}} \right)^{1/3} = 1563$$

The average mass transfer coefficient for the entire plate is

$$\bar{h}_m = \overline{Sh}_L \frac{D_{AB}}{L} = 1563 \frac{0.331 \times 10^{-4} \text{ m}^2/\text{s}}{1 \text{ m}} = 0.0517 \text{ m/s}.$$

The mass rate of water evaporation per unit plate width is

$$n'_A = \bar{h}_m L (\rho_{A,s} - \rho_{A,\infty}) = 0.0517 \text{ m/s} \times 1 \text{ m} (0.260 - 0) \text{ kg}/\text{m}^3 = 0.0135 \text{ kg}/\text{s} \cdot \text{m} \quad <$$

(b) Using Eq. (1) and (3) in the IHT Workspace with the *Correlations Tool, External Flow, Flat Plate, Average coefficient for Laminar or Mixed Flow*, replacing heat transfer with mass transfer parameters, the evaporation rate as a function of a velocity for selected air-water velocities was calculated and is plotted below.

Continued...

### PROBLEM 7.117 (Cont.)

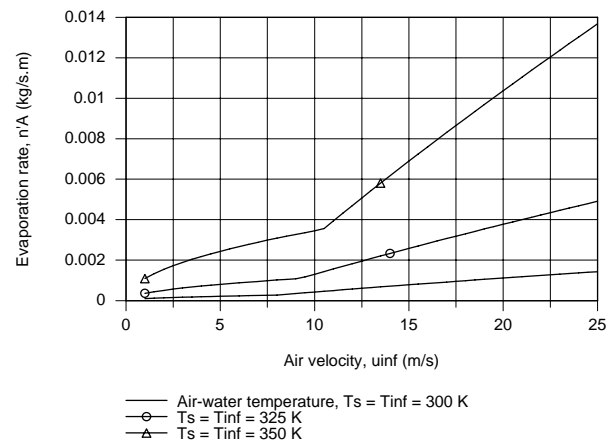

**COMMENTS:** (1) Note carefully the use of the heat-mass transfer analogy, recognizing that air is species B.

(2) How do you explain the abrupt slope changes in the evaporation rate as a function of velocity in the above plot?

## PROBLEM 7.118

**KNOWN:** Temperature of water bath used to dissipate heat from 100 integrated circuits. Air flow conditions.

**FIND:** Heat dissipation per circuit.

**SCHEMATIC:**

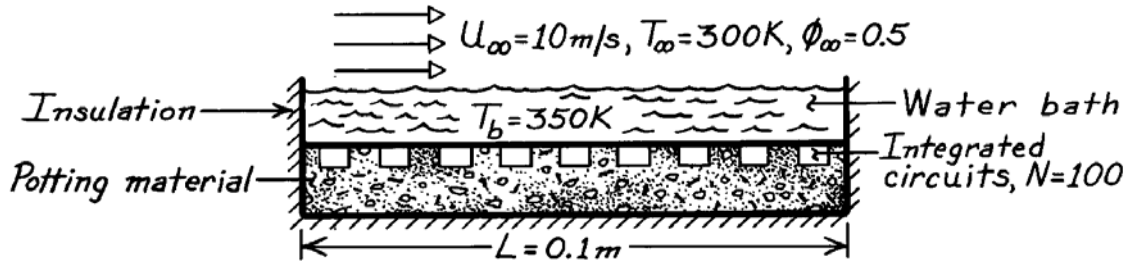

**ASSUMPTIONS:** (1) Heat and mass transfer analogy is applicable, (2) Vapor may be approximated as a perfect gas, (3) Turbulent boundary layer over entire surface, (4) All heat loss is across air-water interface.

**PROPERTIES:** Table A-4, Air (325 K, 1 atm):  $\nu = 18.4 \times 10^{-6} \text{ m}^2/\text{s}$ ,  $k = 0.0282 \text{ W/m}\cdot\text{K}$ ,  $\text{Pr} = 0.704$ ; Table A-8, Air-vapor (325 K, 1 atm):  $D_{AB} = 0.26 \times 10^{-4} \text{ m}^2/\text{s}$ ; Table A-6, Saturated water vapor ( $T_b = 350 \text{ K}$ ):  $\rho_g = 0.260 \text{ kg/m}^3$ ,  $h_{fg} = 2.32 \times 10^6 \text{ J/kg}$ ; ( $T_\infty = 300 \text{ K}$ ):  $\rho_g = 0.026 \text{ kg/m}^3$ .

**ANALYSIS:** The heat rate is

$$q_1 = \frac{q}{N} = \frac{L^2}{N} \left[ q'' + n''_A h_{fg} (T_b) \right].$$

Evaluate the heat and mass transfer convection coefficients with

$$\text{Re}_L = \frac{u_\infty L}{\nu} = \frac{10 \text{ m/s} \times 0.1 \text{ m}}{18.4 \times 10^{-6} \text{ m}^2/\text{s}} = 54,348$$

$$\bar{h} = (k/L) 0.037 \text{Re}_L^{4/5} \text{Pr}^{1/3} = (0.0282 \text{ W/m}\cdot\text{K}/0.1 \text{ m}) 0.037 (54,348)^{4/5} (0.704)^{1/3} = 57 \text{ W/m}^2 \cdot \text{K}$$

$$\bar{h}_m = (D_{AB}/L) 0.037 \text{Re}_L^{4/5} \text{Sc}^{1/3} = (0.296 \times 10^{-4} \text{ m}^2/\text{s}/0.1 \text{ m}) 0.037 (54,348)^{4/5} (0.622)^{1/3} = 0.0574 \text{ m/s}.$$

The convection heat transfer rate is

$$q'' = \bar{h} (T_b - T_\infty) = 57 \text{ W/m}^2 \cdot \text{K} (350 - 300) \text{ K} = 2850 \text{ W/m}^2$$

and the evaporative cooling rate is

$$n''_A h_{fg} = \bar{h}_m \left[ \rho_{A,\text{sat}} (T_b) - \phi_\infty \rho_{A,\text{sat}} (T_\infty) \right] h_{fg} (T_b)$$

$$n''_A h_{fg} = 0.0574 \text{ m/s} [0.260 - 0.5 \times 0.026] \text{ kg/m}^3 \times 2.32 \times 10^6 \text{ J/kg} = 32,890 \text{ W/m}^2$$

Hence

$$q_1 = \frac{(0.1 \text{ m})^2}{100} (2850 + 32,890) \text{ W/m}^2 = 3.57 \text{ W}.$$

<

**COMMENTS:** Heat loss due to evaporative cooling is approximately an order of magnitude larger than that due to the convection of sensible energy.



## PROBLEM 7.119

**KNOWN:** Dry air flows at 300 K over water-filled trays, each 222 mm long, with velocity of 15 m/s while radiant heaters maintain the surface temperature at 330 K.

**FIND:** (a) Evaporative flux ( $\text{kg/s}\cdot\text{m}^2$ ) at a distance 1 m from leading edge, (b) Radiant flux at this distance required to maintain water temperature at 330 K, (c) Evaporation rate from the tray at location  $L = 1 \text{ m}$ ,  $\dot{n}'_A$  ( $\text{kg/s}\cdot\text{m}$ ) and (d) Irradiation which should be applied to each of the first four trays such that their rates are identical to that found in part (c).

**SCHEMATIC:**

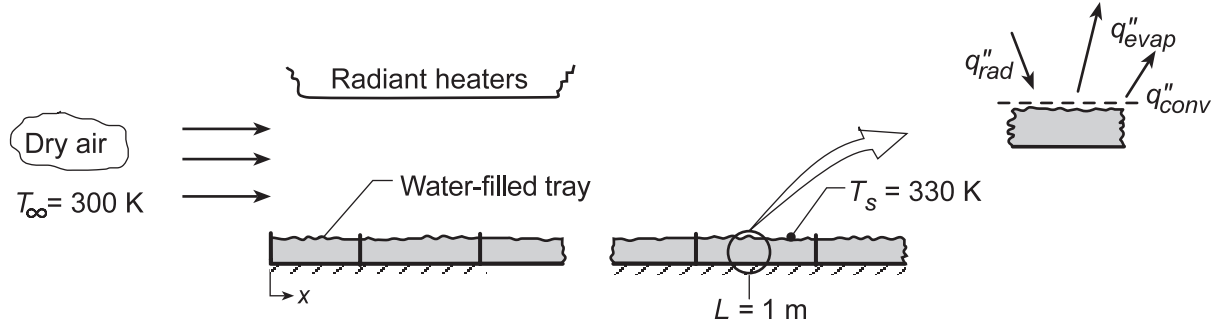

**ASSUMPTIONS:** (1) Steady-state conditions, (2) Heat-mass transfer analogy applicable, (3) Water vapor behaves as perfect gas, (4) All incident radiant power absorbed by water, (5) Critical Reynolds number is  $5 \times 10^5$ .

**PROPERTIES:** Table A.4, Air ( $T_f = 315 \text{ K}$ , 1 atm):  $\nu = 17.40 \times 10^{-6} \text{ m}^2/\text{s}$ ,  $k = 0.0274 \text{ W/m}\cdot\text{K}$ ,  $\text{Pr} = 0.705$ ; Table A.8, Water vapor-air ( $T_f = 315 \text{ K}$ ):  $D_{AB} = 0.26 \times 10^{-4} \text{ m}^2/\text{s}$  ( $315/298$ )<sup>3/2</sup> =  $0.28 \times 10^{-4} \text{ m}^2/\text{s}$ ,  $\text{Sc} = \nu/D_{AB} = 0.616$ ; Table A.6, Saturated water vapor ( $T_s = 330 \text{ K}$ ):  $\rho_{A,\text{sat}} = 1/\nu_g = 0.1134 \text{ kg/m}^3$ ,  $h_{fg} = 2366 \text{ kJ/kg}$ .

**ANALYSIS:** (a) The evaporative flux of water vapor (A) at location  $x$  is

$$\dot{n}'_{A,x} = h_{m,x} (\rho_{A,s} - \rho_{A,\infty}) = h_{m,x} [\rho_{A,\text{sat}}(T_s) - \phi_\infty \rho_{A,\text{sat}}(T_\infty)] \quad (1)$$

Evaluate  $\text{Re}_x$  to determine the nature of the flow and then select the proper correlation.

$$\text{Re}_x = \frac{u_\infty x}{\nu} = 15 \text{ m/s} \times 1 \text{ m} / 17.40 \times 10^{-6} \text{ m}^2/\text{s} = 8.621 \times 10^5.$$

Hence, the flow is turbulent, and invoking the heat-mass analogy with Eq. 7.37,

$$\text{Sh}_x = \frac{h_{m,x}}{D_{AB}} = 0.0296 \text{Re}_x^{4/5} \text{Sc}^{1/3}$$

$$h_m = \frac{0.28 \times 10^{-4} \text{ m}^2/\text{s}}{1 \text{ m}} \times 0.0296 (8.621 \times 10^5)^{4/5} (0.616)^{1/3} = 3.952 \times 10^{-2} \text{ m/s}.$$

Hence, the evaporative flux at  $x = 1 \text{ m}$  is

$$\dot{n}'_{A,x} = 3.952 \times 10^{-2} \text{ m/s} (0.1134 \text{ kg/m}^3 - 0) = 4.48 \times 10^{-3} \text{ kg/s}\cdot\text{m}^2 \quad (2) <$$

(b) From an energy balance on the differential element at  $x = 1 \text{ m}$ ,

$$q''_{\text{rad}} = q''_{\text{conv}} + q''_{\text{evap}} = h_x (T_s - T_\infty) + \dot{n}'_{A,x} h_{fg} \quad (3)$$

Continued...

**PROBLEM 7.119 (Cont.)**

To estimate  $h_x$ , invoke the heat-mass analogy using the correlation, Eq. 7.37,

$$\text{Nu}_x / \text{Sh}_x = (\text{Pr}/\text{Sc})^{1/3} \quad \text{or} \quad h_x = h_{m,x} k / D_{AB} (\text{Pr}/\text{Sc})^{1/3} \quad (4)$$

$$h_x = 3.95 \times 10^{-2} \text{ kg/s} \cdot \text{m}^2 \left( 0.0274 \text{ W/m} \cdot \text{K} / 0.28 \times 10^{-4} \text{ m}^2/\text{s} \right) (0.705/0.616)^{1/3} = 40.45 \text{ W/m}^2 \cdot \text{K}$$

Hence, the required radiant flux is

$$q''_{\text{rad}} = 40.45 \text{ W/m}^2 \cdot \text{K} (330 - 300) \text{ K} + 4.48 \times 10^{-3} \text{ kg/s} \cdot \text{m}^2 \times 2366 \times 10^3 \text{ J/kg}$$

$$q''_{\text{rad}} = 1,214 \text{ W/m}^2 + 10,600 \text{ W/m}^2 = 11,813 \text{ W/m}^2 \quad <$$

(c) The flow is turbulent over tray 5 having its mid-length at  $x = 1 \text{ m}$ , so that it is reasonable to assume,

$$\bar{h}_5 \approx h_x (1 \text{ m}) \quad (5)$$

so that the evaporation rate can be determined from the evaporative flux as,

$$n'_A = n''_{A,x} \Delta L = 4.48 \times 10^{-3} \text{ kg/s} \cdot \text{m}^2 \times 0.222 \text{ m} = 9.95 \times 10^{-4} \text{ kg/s} \cdot \text{m} \quad <$$

(d) For tray 5, following the form of Eq. (3), the energy balance is

$$q''_{\text{rad},5} \Delta L = \bar{h}_5 \Delta L (T_{s,5} - T_\infty) + n'_{A,5} h_{fg} \quad (6)$$

and the evaporation rate for the tray is

$$n'_{A,5} = \bar{h}_{m,5} \Delta L (\rho_{A,s} - 0) \quad (7)$$

While  $\bar{h}_5$  and  $\bar{h}_{m,5}$  represent tray averages, Eq. (4) is still applicable. Using the *IHT Correlation Tool, External Flow, Average coefficient for Laminar, or Mixed Flow*,  $\bar{h}_5$  is evaluated as

$$\bar{h}_5 = \left[ \bar{h}_x (1.10 \text{ m}) L_5 - \bar{h}_x (0.880 \text{ m}) L_4 \right] / \Delta L \quad (8)$$

where  $\Delta L = L_5 - L_4 = 0.22 \text{ m}$ . The same relations can be applied to trays 2, 3 and 4. For tray 1,  $\bar{h}_1 = \bar{h} (0.22 \text{ m}) \cdot L_1$ , where  $L_1 = \Delta L$ . With Eqs. (3, 6, 7 and 8) in the IHT Workspace, along with the *Correlations* and *Properties Tools*, the following results were obtained with the requirement that the evaporation rate for each tray is equal at  $n'_{A,5} = 10.01 \times 10^{-4} \text{ kg/s} \cdot \text{m}$ .

Tray	1	2	3	4	5
$T_s$	342.7	357	348.1	329	330
$q''_{\text{rad}}$	11,920	11,150	11,400	11,950	11,920

**COMMENTS:** (1) Note carefully at which temperatures the thermophysical properties are evaluated.

(2) Recognize that in part (d), if we require equal evaporation rates for each tray,  $n'_{A,5}$ , the water temperature,  $T_s$ , and radiant flux,  $q''_{\text{rad}}$ , for each tray must be different since the convection coefficients  $\bar{h}_x$  and  $\bar{h}_{m,x}$  are different for each of the trays. How do you explain the changes in  $T_s$ ? Which tray has the highest  $\bar{h}$ ? The lowest  $\bar{h}$ ?

(3) For tray 5, using Eq. (5) we found  $\bar{h}_5 = 40.45 \text{ W/m}^2 \cdot \text{K}$ ; using the more accurate formulation, Eq. (8), the result is  $40.49 \text{ W/m}^2 \cdot \text{K}$ . If the flow were laminar or mixed over the tray, Eq. (5) would be inappropriate.

## PROBLEM 7.120

**KNOWN:** Irradiation on sequential water-filled trays of prescribed length and width. Temperature and velocity of airflow over the trays.

**FIND:** Rate of water loss from first, third and fourth trays and temperature of water in each tray.

**SCHEMATIC:**

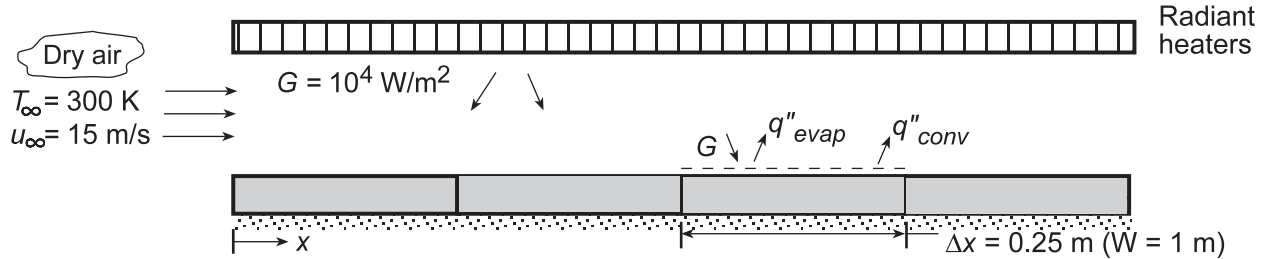

**ASSUMPTIONS:** (1) Steady-state conditions, (2) Uniform irradiation of each container, (3) Complete absorption of irradiation by water, (4) Negligible heat transfer between containers and from bottom of containers, (5) Validity of heat-mass transfer analogy, (6) Applicability of convection correlations for an isothermal surface, (7)  $Re_{x,c} = 5 \times 10^5$ .

**PROPERTIES:** Table A.4, air (1 atm, assume  $T_f = 315$  K):  $\nu = 17.4 \times 10^{-6} \text{ m}^2/\text{s}$ ,  $k = 0.0274 \text{ W/m}\cdot\text{K}$ ,  $Pr = 0.705$ . Table A.8, vapor/air (1 atm, 315 K):  $D_{AB} = 0.26 \times 10^{-4} \text{ m}^2/\text{s}$  ( $315/298$ )<sup>3/2</sup> =  $0.28 \times 10^{-4} \text{ m}^2/\text{s}$ ,  $Sc = \nu/D_{AB} = 0.616$ .

**ANALYSIS:** The temperature of each tray is determined by a balance between the absorbed radiation and the convection and evaporative losses. Hence,

$$G = q''_{\text{conv}} + q''_{\text{evap}} = \bar{h}(T_s - T_\infty) + \bar{h}_m \rho_{A,\text{sat}} h_{fg}$$

where, assuming an exponent of  $n = 1/3$ , the heat-mass transfer analogy yields

$$\bar{h}_m = (D_{AB}/k)(Sc/Pr)^{1/3} \bar{h} = (0.26 \times 10^{-4} \text{ m}^2/\text{s}/0.0274 \text{ W/m}\cdot\text{K})(0.616/0.705)^{1/3} \bar{h} = (9.07 \times 10^{-4} \text{ m}^3 \cdot \text{K}/\text{W} \cdot \text{s}) \bar{h}$$

Hence,

$$G = \bar{h} \left[ (T_s - T_\infty) + 9.07 \times 10^{-4} \rho_{A,\text{sat}} h_{fg} \right]$$

With  $Re_N = u_\infty N \Delta x / \nu = 15 \text{ m/s}(N \times 0.25 \text{ m})/17.4 \times 10^{-6} \text{ m}^2/\text{s} = (2.155 \times 10^5)N$ , the flow is laminar for  $N = 1, 2$  with transition to turbulence occurring for  $N = 3$ .

For tray 1,

$$\begin{aligned} \bar{h} &= (k/\Delta x) 0.664 Re_1^{1/2} Pr^{1/3} \\ &= (0.0274 \text{ W/m}\cdot\text{K}/0.25 \text{ m}) 0.664 (2.155 \times 10^5)^{1/2} (0.705)^{1/3} = 30.1 \text{ W/m}^2 \cdot \text{K} \end{aligned}$$

For tray 4, with  $x = 0.875 \text{ m}$  ( $N = 7/2$ ),

$$\begin{aligned} \bar{h}_4 &\approx (k/x) 0.0296 Re_{7/2}^{4/5} Pr^{1/3} \\ &= (0.0274 \text{ W/m}\cdot\text{K}/0.875 \text{ m}) 0.0296 (7.543 \times 10^5)^{4/5} (0.705)^{1/3} = 41.5 \text{ W/m}^2 \cdot \text{K} \end{aligned}$$

Continued...

**PROBLEM 7.120 (Cont.)**

For tray 3,  $\bar{h}_3 = (\bar{h}_{1-3}L_3 - \bar{h}_{1-2}L_2) / \Delta x$ , where

$$\begin{aligned}\bar{h}_{1-3}L_3 &= k \left( 0.037 \text{Re}_3^{4/5} - 871 \right) \text{Pr}^{1/3} \\ &= 0.0274 \text{ W/m} \cdot \text{K} (0.037 \times 44,510 - 871) (0.705)^{1/3} = 18.9 \text{ W/m} \cdot \text{K}\end{aligned}$$

$$\begin{aligned}\bar{h}_{1-2}L_2 &= k \left( 0.664 \text{Re}_2^{1/2} \text{Pr}^{1/3} \right) \\ &= 0.0274 \text{ W/m} \cdot \text{K} (0.664 \times 656.5) (0.705)^{1/3} = 10.6 \text{ W/m} \cdot \text{K}\end{aligned}$$

$$\bar{h}_3 = (18.9 - 10.6) \text{ W/m} \cdot \text{K} / 0.25 \text{ m} = 33.1 \text{ W/m}^2 \cdot \text{K}$$

For tray 1, the energy balance yields

$$10^4 \text{ W/m}^2 = 30.1 \text{ W/m}^2 \cdot \text{K} \left[ (T_s - T_\infty) + 9.07 \times 10^{-4} \rho_{A,\text{sat}} h_{\text{fg}} \right]$$

Since  $\rho_{A,\text{sat}}$  depends strongly on  $T_s$ , the solution to this equation must be obtained by trial-and-error, with  $\rho_{A,\text{sat}}$  (and  $h_{\text{fg}}$ ) determined from Table A.6. The solution yields

$$T_{s,1} \approx 334.7 \text{ K} \quad <$$

Similarly, for trays 3 and 4

$$T_{s,3} \approx 332.8 \text{ K} \quad T_{s,4} \approx 327.1 \text{ K} \quad <$$

The evaporation rate for tray N is

$$\dot{m}_{\text{evap}} = \bar{h}_m \rho_{A,\text{sat}} (W \Delta x) = 2.27 \times 10^{-4} \bar{h} \rho_{A,\text{sat}}$$

from which it follows that

$$\dot{m}_{\text{evap},1} \approx 9.5 \times 10^{-4} \text{ kg/s}, \quad \dot{m}_{\text{evap},3} \approx 9.5 \times 10^{-4} \text{ kg/s}, \quad \dot{m}_{\text{evap},4} \approx 9.3 \times 10^{-4} \text{ kg/s} \quad <$$

**COMMENTS:** (1) The largest convection coefficient is associated with the tray for which the entire flow is turbulent. (2) The temperature of the water varies inversely with the average convection coefficient for its tray.

## PROBLEM 7.121

**KNOWN:** Apparatus as described in Problem 7.40 providing a nearly uniform airstream over a flat *test plate* to experimentally determine the heat and mass transfer coefficients. Temperature history of the preheated plate for airstream velocities of 3 and 9 m/s were fitted to a fourth-order polynomial for determining the heat transfer coefficient. Water mass loss observations from a water-saturated paper over the plate and its surface temperature for determining the heat transfer coefficient.

**FIND:** (a) From the temperature-time history, determine the heat transfer coefficients and evaluate the constants  $C$  and  $m$  for a correlation of the form  $\overline{Nu}_L = C Re^m Pr^{1/3}$ ; compare results with a standard-plate correlation and comment on the goodness of the comparison; explain any differences; (b) From the water mass loss observations, determine the mass transfer coefficients for the two flow conditions; evaluate the constants  $C$  and  $m$  for a correlation of the form  $\overline{Sh}_L = C Re^m Sc^{1/3}$ ; and (c) Using the heat-mass analogy, compare the experimental results with each other and against standard correlations; comment on the goodness of the comparison; explain any differences.

**SCHEMATIC:**

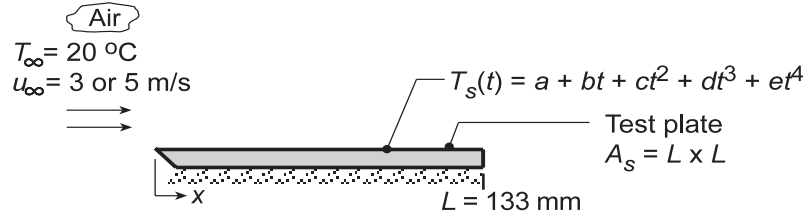

(a) Heat transfer experiment

Temperature Observations		
$u_\infty$ (m/s)	3	9
$\Delta t$ (s)	300	160
$a$ ( $^\circ\text{C}$ )	56.87	57.00
$b$ ( $^\circ\text{C/s}$ )	-0.1472	-0.2641
$c$ ( $^\circ\text{C/s}^2$ )	$3 \times 10^{-4}$	$9 \times 10^{-4}$
$d$ ( $^\circ\text{C/s}^3$ )	$-4 \times 10^{-7}$	$-2 \times 10^{-6}$
$e$ ( $^\circ\text{C/s}^4$ )	$2 \times 10^{-10}$	$1 \times 10^{-9}$

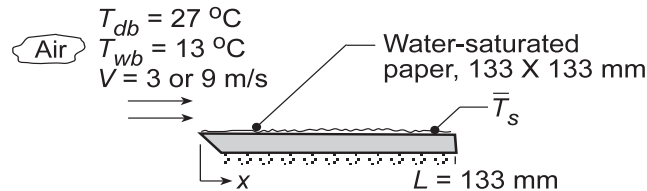

(b) Mass transfer experiment

Mass Loss Observations				
$V$	$\overline{T}_s$	$m(t)$	$m(t + \Delta t)$	$\Delta t$
(m/s)	( $^\circ\text{C}$ )	(g)	(g)	(s)
3	15.3	55.62	54.45	475
9	16.0	55.60	54.50	240

**ASSUMPTIONS:** (1) Airstream over the test plate approximates parallel flow over a flat plate, (2) Plate is spacewise isothermal, (3) Negligible radiation exchange between plate and surroundings, (4) Constant properties, and (5) Negligible heat loss from the bottom surface or edges of the test plate.

**PROPERTIES:** *Heat transfer coefficient, Table A.4, Air* ( $T_f = (\overline{T}_s + T_\infty)/2 = 310 \text{ K}$ , 1 atm):  $k_a = 0.0269 \text{ W/m}\cdot\text{K}$ ,  $\nu = 1.669 \times 10^{-5} \text{ m}^2/\text{s}$ ,  $Pr = 0.706$ . *Test plate (Given):*  $\rho = 2770 \text{ kg/m}^3$ ,  $c_p = 875 \text{ J/kg}\cdot\text{K}$ ,  $k = 177 \text{ W/m}\cdot\text{K}$ . *Mass transfer coefficient: Table A.6, Water vapor* ( $\overline{T}_s = 15.3^\circ\text{C} = 288.3 \text{ K}$ ):  $\rho_{A,\text{sat}} = 1/v_g = 79.81 \text{ m}^3/\text{kg} = 0.01253 \text{ kg/m}^3$ ; *Table A.6, Water vapor* ( $\overline{T}_s = 16.0^\circ\text{C} = 289 \text{ K}$ ):  $\rho_{A,\text{sat}} = 0.01322 \text{ kg/m}^3$ ; *Table A.6, Water vapor* ( $T_{\text{inf}} = 27^\circ\text{C} = 300 \text{ K}$ ):  $\rho_{A,\text{sat}} = 0.02556 \text{ kg/m}^3$ ; *Table A.8, Water vapor-air* [ $T_f = (\overline{T}_s + T_\infty)/2 \approx 295 \text{ K}$ ]:  $D_{AB} = 0.26 \times 10^{-4} \text{ m}^2/\text{s} (295/298)^{1.5} = 0.256 \times 10^{-4} \text{ m}^2/\text{s}$ .

**ANALYSIS:** (a) Using the lumped-capacitance method, the energy balance on the plate is

$$-\overline{h}_L A_s [T_s(t) - T_\infty] = \rho V c_p \frac{dT}{dt} \quad (1)$$

Continued...

### PROBLEM 7.121 (Cont.)

and the average convection coefficient can be determined from the temperature history,  $T_s(t)$ ,

$$\bar{h}_L = \frac{\rho V c_p}{A_s} \frac{(dT/dt)}{T_s(t) - T_\infty} \quad (2)$$

where the temperature-time derivative is

$$\frac{dT_s}{dt} = b + 2ct + 3dt^2 + 4et^3 \quad (3)$$

The temperature time history plotted below shows the experimental behavior of the observed data.

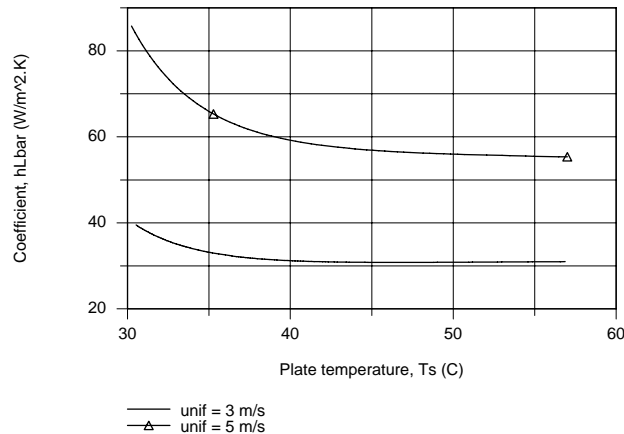

Consider now the integrated form of the energy balance, Eq. (5.6), expressed as

$$\ln \frac{T_s(t) - T_\infty}{T_i - T_\infty} = - \left( \frac{\bar{h}_L A_s}{\rho V c} \right) t \quad (4)$$

If we were to plot the LHS vs  $t$ , the slope of the curve would be proportional to  $\bar{h}_L$ . Using IHT, plots were generated of  $\bar{h}_L$  vs.  $T_s$ , Eq. (1), and  $\ln \left[ (T_s(t) - T_\infty) / (T_i - T_\infty) \right]$  vs.  $t$ , Eq. (4). From the latter plot, recognize that the regions where the slope is constant corresponds to early times ( $\leq 100$ s when  $u_\infty = 3$  m/s and  $\leq 50$ s when  $u_\infty = 5$  m/s).

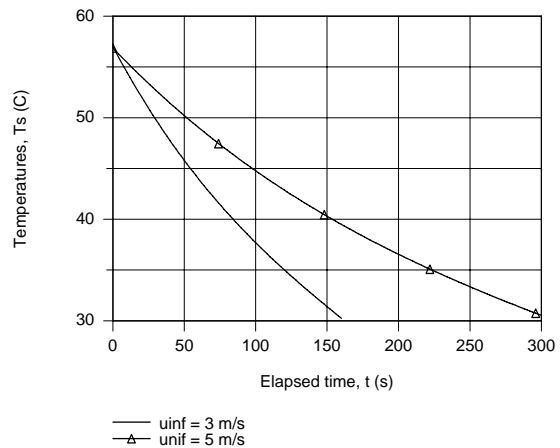
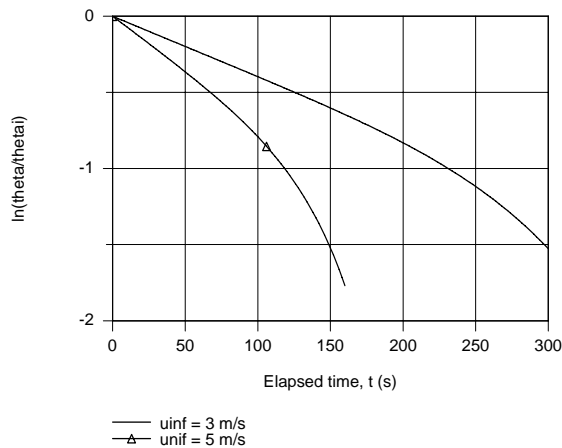

Continued...

### PROBLEM 7.121 (Cont.)

Selecting two elapsed times at which to evaluate  $\bar{h}_L$ , the following results were obtained

$u_\infty$ (m/s)	$t$ (s)	$T_s$ (t), ( $^\circ\text{C}$ )	$\bar{h}_L$ ( $\text{W}/\text{m}^2\cdot\text{K}$ )	$\overline{\text{Nu}}_L$	$\text{Re}_L$
3	100	44.77	30.81	152.4	$2.39 \times 10^4$
9	50	45.80	56.7	280.4	$7.17 \times 10^4$

where the dimensionless parameters are evaluated as

$$\overline{\text{Nu}}_L = \frac{\bar{h}_L L}{k_a} \quad \text{Re}_L = \frac{u_\infty L}{\nu} \quad (5,6)$$

where  $k_a$ ,  $\nu$  are thermophysical properties of the airstream.

(b) Using the above pairs of  $\overline{\text{Nu}}_L$  and  $\text{Re}_L$ ,  $C$  and  $m$  in the correlation can be evaluated,

$$\overline{\text{Nu}}_L = C \text{Re}_L^m \text{Pr}^{1/3} \quad (7)$$

$$152.4 = C(2.39 \times 10^4)^m (0.706)^{1/3} \quad 280.4 = C(7.17 \times 10^4)^m (0.706)^{1/3}$$

Solving, find  $C = 0.633$   $m = 0.555$  (8,9) <

The plot below compares the experimental correlation ( $C = 0.633$ ,  $m = 0.555$ ) with those for laminar flow ( $C = 0.664$ ,  $m = 0.5$ ) and fully turbulent flow ( $C = 0.037$ ,  $m = 0.8$ ). The experimental correlation yields  $\overline{\text{Nu}}_L$  values which are 25% higher than for the correlation. The most likely explanation for this unexpected trend is that the airstream reaching the plate is not parallel, but with a slight impingement effect and/or the flow is very highly turbulent at the leading edge.

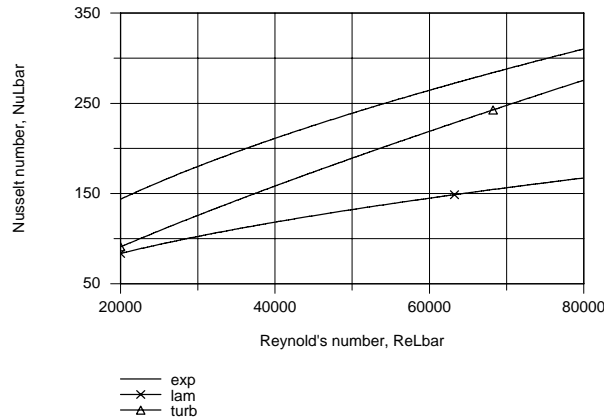

(b) From the convection mass transfer rate equation,

$$n_A = \bar{h}_{m,L} A_s (\rho_{A,s} - \rho_{A,\infty}) \quad (10)$$

where the evaporation rate can be determined from the paper mass and time interval observations,

$$n_A = \frac{[m(t + \Delta t) - m(t)]}{\Delta t} \quad (11)$$

and the species densities,  $\rho_{A,s}$  and  $\rho_{A,\infty}$ , correspond to  $\rho_{A,\text{sat}}(\bar{T}_s)$  and  $\phi_\infty \rho_{A,\text{sat}}(T_\infty)$ , respectively.

Using the ASHRAE psychrometric chart (1 atm) with  $T_{\text{wb}} = 13^\circ\text{C}$  and  $T_{\text{db}} = 27^\circ\text{C}$ , find the relative humidity as  $\phi_\infty = 0.17$ . The correlation dimensionless parameters are evaluated as

$$\overline{\text{Sh}}_L = \frac{\bar{h}_{m,L} L}{D_{AB}} \quad \text{Re}_L = \frac{u_\infty L}{\nu} \quad \text{Sc} = \frac{\nu}{D_{AB}} \quad (12,13,14)$$

Continued...

**PROBLEM 7.121 (Cont.)**

where all the properties are evaluated at  $T_f = (\bar{T}_S + T_\infty)/2$ . The results of the analyses are summarized in the following table.

$u_\infty$	$n_A$	$\bar{h}_{m,L}$	$\bar{Sh}_L$	$Re_L$	$Sc$
(m/s)	kg/s	(m/s)			
3	$2.463 \times 10^{-6}$	0.0168	87.58	$2.594 \times 10^4$	0.603
9	$4.583 \times 10^{-6}$	0.0288	150	$7.767 \times 10^4$	0.603

Using the two sets of tabulated values for  $\bar{Sh}_L$ ,  $Re_L$  and  $Sc$  and the standard correlation of the form,

$$\bar{Sh}_L = C Re_L^m Sc^{1/3} \tag{15}$$

$$87.58 = C (2.594 \times 10^4)^m (0.603)^{1/3} \qquad 150 = C (7.767 \times 10^4)^m (0.603)^{1/3}$$

solve simultaneously to find  $C = 0.711$   $m = 0.490$  (16,17)

From the heat-mass analogy, we expect the constants  $C$  and  $m$  in Eq. (7) for heat transfer and in Eq. (13) for mass transfer to be the same. From the two experiments, we found

	$C$	$m$
Heat transfer	0.633	0.555
Mass transfer	0.711	0.490

In the plot below, the parameters  $\bar{Sh}_L/Sc^{1/3}$  or  $\bar{Nu}_L/Pr^{1/3}$  are plotted against  $Re_L$  using Eq. (15) or (7). Note that the curves are nearly parallel on the log-log axes since their “ $m$ ” constants are of similar value. The mass transfer results are, however, nearly 50% higher than those for heat transfer. We have no way to explain this systematic difference without more information on the apparatus, observation procedures and repeated observations. However, overall the results support the general form of the heat-mass analogy.

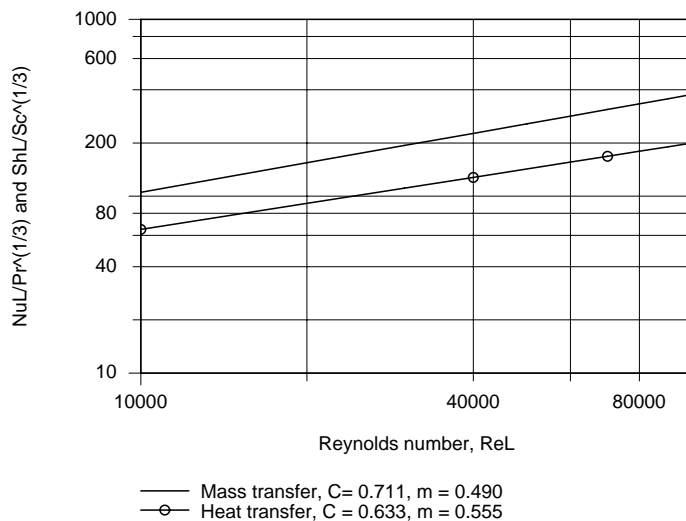



## PROBLEM 7.122

**KNOWN:** Dry air at prescribed temperature and velocity flowing over a wetted plate of length 500 mm and width 150 mm. Imbedded electrical heater maintains the surface at  $T_s = 20^\circ\text{C}$ .

**FIND:** (a) Water evaporation rate (kg/h) and electrical power  $P_e$  (W) required to maintain steady-state conditions, and (b) The temperature of the plate after all the water has evaporated, for the same airstream conditions and heater power of part (a).

**SCHEMATIC:**

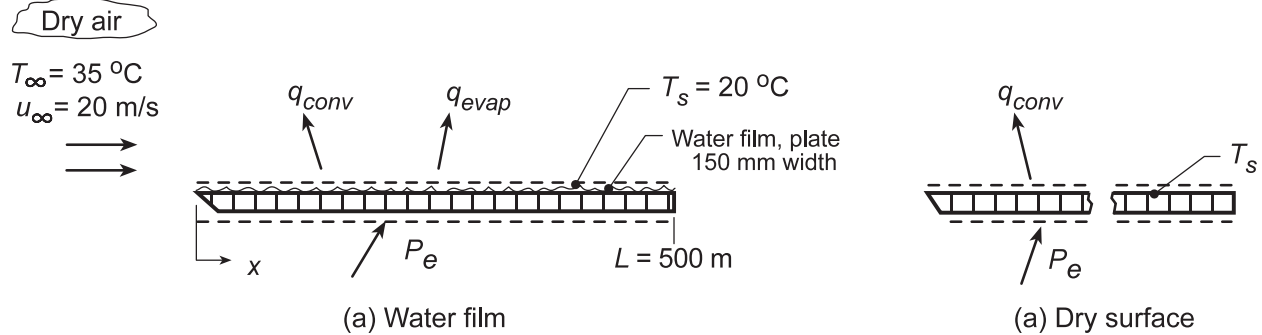

**ASSUMPTIONS:** (1) Steady-state conditions, (2) Constant properties and (3) Heat-mass transfer analogy is applicable.

**PROPERTIES:** Table A.4, Air ( $T_f = (T_s + T_\infty)/2 = 300\text{ K}$ , 1 atm):  $\rho = 1.16\text{ kg/m}^3$ ,  $c_p = 1007\text{ J/kg}\cdot\text{K}$ ,  $k = 0.0263\text{ W/m}\cdot\text{K}$ ,  $\nu = 15.94 \times 10^{-6}\text{ m}^2/\text{s}$ ,  $\alpha = 2.257 \times 10^{-5}\text{ m}^2/\text{s}$ , Table A.6, Water ( $T_s = 20^\circ\text{C} = 293\text{ K}$ ):  $\rho_{A,s} = 1/\nu_g = 1/59.04 = 0.0169\text{ kg/m}^3$ ,  $h_{fg} = 2454\text{ kJ/K}$ ; Table A.8, Water-air ( $T_f = 300\text{ K}$ ):  $D_{AB} = 0.26 \times 10^{-4}\text{ m}^2/\text{s}$ .

**ANALYSIS:** (a) Perform an energy balance on the plate,

$$\dot{E}_{\text{in}} - \dot{E}_{\text{out}} = 0 \quad P_e - q_{\text{conv}} - q_{\text{evap}} = 0 \quad (1)$$

where the convection and evaporation rate equations are,

$$q_{\text{conv}} = \bar{h}_L A_s (T_s - T_\infty) \quad (2)$$

$$q_{\text{evap}} = n_A h_{fg} = \bar{h}_m A_s (\rho_{A,s} - \rho_{A,\infty}) h_{fg} \quad (3)$$

The Reynolds number for the plate length  $L$  is

$$\text{Re}_L = \frac{u_\infty L}{\nu} = \frac{20\text{ m/s} \times 0.50\text{ m}}{15.94 \times 10^{-6}\text{ m}^2/\text{s}} = 6.274 \times 10^5$$

so that the flow is mixed and Eq. 7.38 is appropriate to estimate  $\bar{h}_L$ ,

$$\begin{aligned} \overline{\text{Nu}}_L &= \frac{\bar{h}_L L}{k} = \left(0.037 \text{Re}_D^{4/5} - 871\right) \text{Pr}^{1/3} \\ \bar{h}_L &= \frac{0.0263\text{ W/m}\cdot\text{K}}{0.5\text{ m}} \left(0.037 \left[6.274 \times 10^5\right]^{4/5} - 871\right) (0.707)^{1/3} = 34.5\text{ W/m}^2\cdot\text{K} \end{aligned}$$

Invoking the heat-mass analogy, Chapter 6, with  $n = 1/3$

$$\frac{\bar{h}_L}{\bar{h}_m} = \rho c_p \left(\frac{\alpha}{D_{AB}}\right)^{-2/3} = 1.16\text{ kg/m}^3 \times 1007\text{ J/kg}\cdot\text{K} \left(\frac{2.257 \times 10^{-5}\text{ m}^2/\text{s}}{0.26 \times 10^{-4}\text{ m}^2/\text{s}}\right)^{-2/3} = 1284\text{ J/m}^3\cdot\text{K}$$

Continued...

**PROBLEM 7.122 (Cont.)**

$$\bar{h}_m = 34.5 \text{ W/m}^2 \cdot \text{K} / 1284 \text{ J/m}^3 \cdot \text{K} = 0.0269 \text{ m/s}$$

Substituting numerical values, the energy balance, Eq. (1), with  $A_s = 0.5 \text{ m} \times 0.15 \text{ m} = 0.075 \text{ m}^2$ ,

$$P_e - 34.5 \text{ W/m}^2 \cdot \text{K} \times 0.075 \text{ m}^2 (20 - 35) \text{ K} \\ - 0.0269 \text{ m/s} \times 0.075 \text{ m}^2 (0.0169 - 0) \text{ kg/m}^3 \times 2454 \times 10^3 \text{ J/kg} \cdot \text{K} = 0$$

$$P_e = -38.8 \text{ W} + 83.7 = 44.9 \text{ W}$$

<

The evaporation rate is

$$n_A = \bar{h}_m A_s (\rho_{A,s} - \rho_{A,\infty}) = 0.0269 \text{ m/s} \times 0.075 \text{ m}^2 \times 0.0169 \text{ kg/m}^3 \times 3600 \text{ s/h} = 0.123 \text{ kg/h}$$

<

(b) When the plate is dry, the energy balance is

$$P_e = \bar{h}_L A_s (T_s - T_\infty)$$

and with  $P_e$  and  $\bar{h}_L$  as determined in part (a),

$$T_s = T_\infty + P_e / \bar{h}_L A_s = 35^\circ \text{C} + 44.9 \text{ W} / 34.5 \text{ W/m}^2 \cdot \text{K} \times 0.075 \text{ m}^2 = 52.3^\circ \text{C}$$

<

**COMMENTS:** Using *IHT Correlations Tool, External Flow, Flat Plate*, the calculation of part (b) was performed using the proper film temperature,  $T_f = 318 \text{ K}$ , to find  $\bar{h}_L = 32.7 \text{ W/m}^2 \cdot \text{K}$  and  $T_s = 53.3^\circ \text{C}$ .

### PROBLEM 7.123

**KNOWN:** Convection mass transfer with turbulent flow over a flat plate (van roof).

**FIND:** (a) Location on van that will dry last, (b) Evaporation rate at trailing edge,  $\text{kg/s}\cdot\text{m}^2$ .

**SCHEMATIC:**



**ASSUMPTIONS:** (1) Turbulent flow over entire plate (van top), (2) Heat-mass transfer analogy is applicable, (3) Perfect gas behavior for water vapor (A).

**PROPERTIES:** Table A-4, Air (300 K, 1 atm):  $\nu = 15.89 \times 10^{-6} \text{ m}^2/\text{s}$ ,  $k = 0.0263 \text{ W/m}\cdot\text{K}$ ,  $\text{Pr} = 0.707$ ; Table A-8, Air-water vapor (25°C):  $D_{AB} = 0.26 \times 10^{-4} \text{ m}^2/\text{s}$ ; Table A-6, Saturated water vapor (300K):  $\rho_{A,\text{sat}} = \nu_g^{-1} = 0.0256 \text{ kg/m}^3$ .

**ANALYSIS:** (a) The mass transfer coefficient,  $h_m(x)$ , will be largest at  $x = 0$  and smallest at  $x = L$  for turbulent flow conditions. Hence, the trailing edge will dry last.

(b) The evaporation rate on a per unit area basis, at the trailing edge where  $x = L$ , is given by the rate equation,

$$n''_A = h_{m,L} (\rho_{A,s} - \rho_{A,\infty}) = h_{m,L} \rho_{A,\text{sat}} (1 - \phi_\infty)$$

For turbulent flow the appropriate correlation for estimating  $h_{m,L}$  is of the form

$$\text{Sh}_x = h_{m,x} x / D_{AB} = 0.0296 \text{Re}_x^{4/5} \text{Sc}^{1/3}.$$

Substituting numerical values,

$$\text{Re}_L = \frac{u_\infty L}{\nu_B} = \frac{90 \times 10^3 \text{ m/h}}{3600 \text{ s/h}} \times 6 \text{ m} / 15.89 \times 10^{-6} \text{ m}^2/\text{s} = 9.44 \times 10^6$$

$$\text{Sc} = \frac{\nu_B}{D_{AB}} = 15.89 \times 10^{-6} \text{ m}^2/\text{s} / 0.26 \times 10^{-4} \text{ m}^2/\text{s} = 0.611$$

$$h_{m,L} = \left( 0.26 \times 10^{-4} \text{ m}^2/\text{s} / 6 \text{ m} \right) \times 0.0296 \left( 9.44 \times 10^6 \right)^{4/5} (0.611)^{1/3} = 0.0414 \text{ m/s}.$$

Hence, the evaporation flux (rate per unit area) is

$$n''_A = 0.0414 \text{ m/s} \times 0.0256 \text{ kg/m}^3 (1 - 0.8) = 2.12 \times 10^{-4} \text{ kg/s}\cdot\text{m}^2. \quad <$$

**COMMENTS:** Recognize how the heat-mass analogy is utilized and the appropriate correlation selected from Table 7.7.

### PROBLEM 7.124

**KNOWN:** Length and thickness of a layer of benzene. Velocity and temperature of air in parallel flow over the layer.

**FIND:** Time required for complete evaporation.

**SCHEMATIC:**

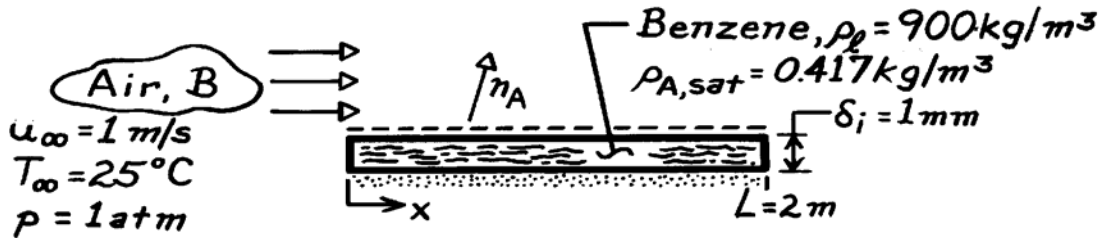

**ASSUMPTIONS:** (1) Steady-state conditions, (2) Smooth liquid surface and negligible free-stream turbulence, (3) Heat and mass transfer analogy is applicable, (4) Negligible benzene vapor concentration in free-stream air, (5) Isothermal conditions at  $25^\circ\text{C}$ .

**PROPERTIES:** Table A-4, Air ( $25^\circ\text{C}$ , 1 atm):  $\nu = 15.7 \times 10^{-6} \text{ m}^2/\text{s}$ ; Table A-8, Benzene-air, ( $25^\circ\text{C}$ , 1 atm):  $D_{AB} = 0.88 \times 10^{-5} \text{ m}^2/\text{s}$ ,  $Sc = 1.78$ .

**ANALYSIS:** Applying conservation of mass to a control volume about the liquid,

$$\frac{dM}{dt} = \frac{d(\rho_l V)}{dt} = -n_A.$$

For a unit width,  $V = L \cdot \delta$ . Hence

$$\rho_l L \frac{d\delta}{dt} = -n'_A = -\bar{h}_m L (\rho_{A,\text{sat}} - \rho_{A,\infty})$$

and integrating

$$\int_{\delta_i}^0 d\delta = -\frac{\bar{h}_m}{\rho_l} \rho_{A,\text{sat}} \int_0^t dt$$

$$t = \frac{\delta_i \rho_l}{\bar{h}_m \rho_{A,\text{sat}}}.$$

With  $Re_L = \frac{u_\infty L}{\nu} = \frac{1 \text{ m/s} \times 2 \text{ m}}{15.7 \times 10^{-6} \text{ m}^2/\text{s}} = 1.27 \times 10^5,$

the flow is laminar throughout and from Eq. 7.31,

$$\bar{h}_m = \frac{D_{AB}}{L} 0.664 Re_L^{1/2} Sc^{1/3} = \frac{0.88 \times 10^{-5} \text{ m}^2/\text{s}}{2 \text{ m}} \times 0.664 (1.27 \times 10^5)^{1/2} (1.78)^{1/3}$$

$$\bar{h}_m = 1.26 \times 10^{-3} \text{ m/s}$$

and

$$t = \frac{0.001 \text{ m} (900 \text{ kg/m}^3)}{(1.26 \times 10^{-3} \text{ m/s}) (0.417 \text{ kg/m}^3)} = 1713 \text{ s} = 28.6 \text{ min.}$$

<

### PROBLEM 7.125

**KNOWN:** Parallel air flow over a series of water-filled trays.

**FIND:** Power required to maintain each of the first three trays at 300K.

**SCHEMATIC:**

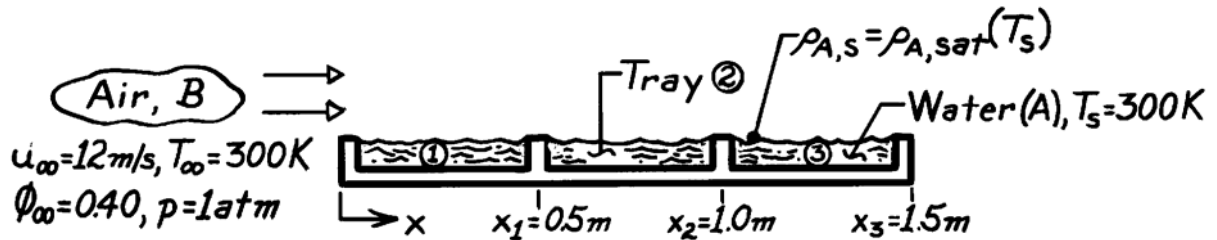

**ASSUMPTIONS:** (a) Steady-state conditions, (2) Heat-mass transfer analogy applicable, (3) Perfect gas behavior for water vapor, (4)  $Re_{x,c} = 5 \times 10^5$ .

**PROPERTIES:** Table A-4, Air (300 K, 1 atm):  $\nu = \nu_B = 15.89 \times 10^{-6} \text{ m}^2/\text{s}$ ; Table A-8, Water vapor-air (300K):  $D_{AB} = 0.26 \times 10^{-4} \text{ m}^2/\text{s}$ ,  $Sc = \nu_B/D_{AB} = 0.611$ ; Table A-6, Saturated water vapor (300K):  $\rho_{A,sat} = \nu_g^{-1} = 0.02556 \text{ kg/m}^3$ ,  $h_{fg} = 2438 \text{ kJ/kg}$ .

**ANALYSIS:** Since  $T_s = T_\infty$ , there is no convective heat transfer, hence,

$$q_{\text{tray}} = \dot{m}_{\text{tray}} h_{fg} = \bar{h}_m \cdot A_s \cdot \rho_{A,sat} (1 - \phi_\infty) h_{fg} \quad (1)$$

where

$\phi_\infty \equiv \rho_{A,\infty} / \rho_{A,sat}$  and  $\rho_{A,s} = \rho_{A,sat}(T_s)$ . Calculate the Reynolds number at  $x_3$ ,

$$Re_{x3} = u_\infty x_3 / \nu_B = 12 \text{ m/s} \times 1.5 \text{ m} / 15.89 \times 10^{-6} \text{ m}^2/\text{s} = 1.133 \times 10^6$$

finding that transition occurs at  $x = 0.662 \text{ m}$ , a location on tray 2. The average mass transfer coefficients  $\bar{h}_m$  and heat rates for each tray are as follows:

*Tray 1:* The flow is laminar and the appropriate correlation for  $\bar{h}_{m,1}$  and heat rate are

$$\overline{Sh}_{x1} = \bar{h}_{m,1} x_1 / D_{AB} = 0.664 Re_{x1}^{1/2} Sc^{1/3}$$

$$\bar{h}_{m,1} = \left( 0.26 \times 10^{-4} \text{ m}^2/\text{s} / 0.5 \text{ m} \right) \times 0.664 \left( \frac{12 \text{ m/s} \times 0.5 \text{ m}}{15.89 \times 10^{-6} \text{ m}^2/\text{s}} \right)^{1/2} (0.611)^{1/3} = 1.800 \times 10^{-2} \text{ m/s}$$

$$q'_1 = 1.800 \times 10^{-2} \text{ m/s} \times 0.5 \text{ m} \times 0.02556 \text{ kg/m}^3 (1 - 0.40) \times 2438 \times 10^3 \text{ J/kg} = 337 \text{ W/m.} \quad <$$

*Tray 2:* Since transition occurs over the span of tray 2, the rate equation has the form

$$q'_2 = \left[ x_2 \bar{h}_{m,0-2} - x_1 \bar{h}_{m,0-1} \right] \rho_{A,sat} (1 - \phi_\infty) h_{fg}. \quad (2)$$

Continued ....

### PROBLEM 7.125 (Cont.)

Note that  $\bar{h}_{m,0-1} = \bar{h}_{m,1}$  from above and that  $\bar{h}_{m,0-2}$  is evaluated using the correlation

$$\overline{Sh}_x = \left(0.037 Re_x^{4/5} - 871\right) Sc^{1/3}$$

$$\bar{h}_{m,0-2} = 2.193 \times 10^{-2} \text{ m/s} \quad q'_2 = 483 \text{ W/m.} \quad <$$

*Tray 3:* The rate equation is of the same form as Eq. (2). Alternatively, an approximation can be used,

$$q'_3 = h_m(\bar{x}) (x_3 - x_2) \rho_{A,sat} (1 - \phi_\infty) h_{fg}$$

where  $h_m(\bar{x})$  is the *local* value at the midspan,  $\bar{x} = (x_2 + x_3)/2$ . Using

$$\overline{Sh}_x = 0.0296 Re_x^{4/5} Sc^{1/3}$$

and substituting numerical values, find

$$h_m(\bar{x}) = 3.148 \times 10^{-2} \text{ m/s} \quad q'_3 = 589 \text{ W/m.} \quad <$$

### PROBLEM 7.126

**KNOWN:** Air and surface conditions for a drying process in which photographic plates are aligned in the direction of the air flow.

**FIND:** (a) Variation of local mass transfer convection coefficient, (b) Drying rate for fastest drying plate, (c) Heat addition needed to maintain the plate temperature.

**SCHEMATIC:**

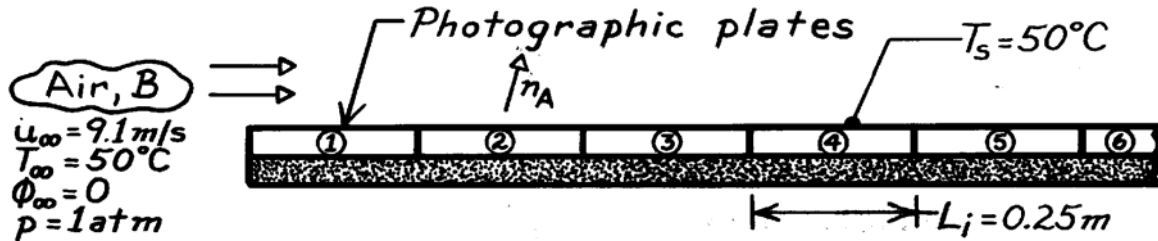

**ASSUMPTIONS:** (1) Heat and mass transfer analogy is applicable, (2) Critical Reynolds number is  $Re_{x,c} = 5 \times 10^5$ , (3) Radiation effects are negligible.

**PROPERTIES:** Table A-4, Air ( $50^\circ\text{C} = 323\text{K}$ ):  $\nu = 18.2 \times 10^{-6} \text{ m}^2/\text{s}$ ; Table A-6, Water vapor ( $50^\circ\text{C} = 323\text{K}$ ):  $\rho_{A,\text{sat}} = 0.082 \text{ kg/m}^3$ ,  $h_{fg} = 2383 \text{ kJ/kg}$ ; Table A-8, Water vapor-air ( $25^\circ\text{C} = 298\text{K}$ )  $D_{AB} = 0.26 \times 10^{-4} \text{ m}^2/\text{s}$ ; since  $D_{AB} \propto T^{3/2}$ ,  $D_{AB}(50^\circ\text{C} = 323\text{K}) = 0.26 \times 10^{-4} (323/298)^{3/2} = 0.29 \times 10^{-4} \text{ m}^2/\text{s}$ ,  $Sc = \nu/D_{AB} = 0.62$ .

**ANALYSIS:** (a) With  $Re_{x,c} = u_\infty x_c / \nu = 5 \times 10^5$ , the point of transition is

$$x_c = \frac{5 \times 10^5 (18.2 \times 10^{-6} \text{ m}^2/\text{s})}{9.1 \text{ m/s}} = 1 \text{ m}$$

and the variation of the local mass transfer coefficient is as shown below

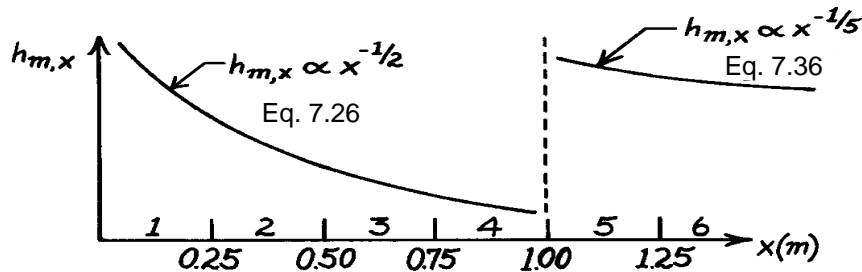

(b) The largest evaporation will be associated with either the first plate or the fifth plate. For the *first* plate,

$$n_{A,1} = \bar{h}_{m,1} A_{s,1} (\rho_{A,s} - \rho_{A,\infty})$$

where  $\rho_{A,\infty} = 0$  since the upstream air is dry. Since the boundary layer is laminar over the entire plate, with

$$Re_{x,1} = (9.1 \text{ m/s}) (0.25 \text{ m}) / (18.2 \times 10^{-6} \text{ m}^2/\text{s}) = 1.25 \times 10^5$$

Continued ...

**PROBLEM 7.126 (Cont.)**

Eq. 7.31 may be used to obtain

$$\bar{h}_{m,1} = \left( \frac{D_{AB}}{x_1} \right) 0.664 \text{Re}_{x,1}^{1/2} \text{Sc}^{1/3} = \left( \frac{0.29 \times 10^{-4} \text{ m}^2/\text{s}}{0.25 \text{ m}} \right) 0.664 \left( 1.25 \times 10^5 \right)^{1/2} (0.62)^{1/3}$$

$$\bar{h}_{m,1} = 0.0232 \text{ m/s.}$$

Hence  $n_{A,1} = 0.0232 \text{ m/s} (0.25 \text{ m} \times 1 \text{ m}) (0.082 \text{ kg/m}^3) = 4.72 \times 10^{-4} \text{ kg/s} \cdot \text{m}.$

For the *fifth* plate,

$$n_{A,5} = n_{A,0-5} - n_{A,0-4} = \left[ (\bar{h}_m A_s)_{0-5} - (\bar{h}_m A_s)_{0-4} \right] (\rho_{A,s} - \rho_{A,\infty}).$$

With  $\text{Re}_{x,5} = 6.25 \times 10^5$ , Eq. 7.41 gives

$$\bar{h}_{m,0-5} = \left( \frac{D_{AB}}{x_5} \right) \left[ 0.037 \text{Re}_{x,5}^{4/5} - 871 \right] \text{Sc}^{1/3}$$

$$\bar{h}_{m,0-5} = \left( \frac{0.29 \times 10^{-4} \text{ m}^2/\text{s}}{1.25 \text{ m}} \right) \left[ 0.037 (6.25 \times 10^5)^{4/5} - 871 \right] (0.62)^{1/3}$$

$$\bar{h}_{m,0-5} = 0.0145 \text{ m/s.}$$

With  $\text{Re}_{x,4} = 5 \times 10^5$ , Eq. 7.31 gives

$$\bar{h}_{m,0-4} = \left( \frac{D_{AB}}{x_4} \right) 0.664 \text{Re}_{x,4}^{1/4} \text{Sc}^{1/3}$$

$$\bar{h}_{m,0-4} = \left( \frac{0.29 \times 10^{-4} \text{ m}^2/\text{s}}{1 \text{ m}} \right) \left[ 0.664 (5 \times 10^5)^{1/2} (0.62)^{1/3} \right]$$

$$\bar{h}_{m,0-4} = 0.0116 \text{ m/s.}$$

Hence,

$$n_{A,5} = [0.0145 \text{ m/s} \times 1.25 \text{ m} \times 1 \text{ m} - 0.0116 \text{ m/s} \times 1 \text{ m} \times 1 \text{ m}] (0.082 \text{ kg/m}^3)$$

$$n_{A,5} = 5.35 \times 10^{-4} \text{ kg/s} \cdot \text{m.} \quad <$$

Hence the evaporation rate is largest for Plate 5.

(c) Heat would have to be supplied to each plate at a rate which is equal to the evaporative cooling rate in order to maintain the prescribed temperature. Hence

$$q_5 = n_{A,5} h_{fg} = 5.35 \times 10^{-4} \text{ kg/s} \cdot \text{m} \times 2.383 \times 10^6 \text{ J/kg} = 1.275 \text{ kW/m.} \quad <$$

**COMMENTS:** The large value of  $q_5$  is a consequence of the significant evaporative cooling effect.



### PROBLEM 7.127

**KNOWN:** Dimensions and temperature of a cooling pond. Conditions of air flow.

**FIND:** Daily make-up water requirement.

**SCHEMATIC:**

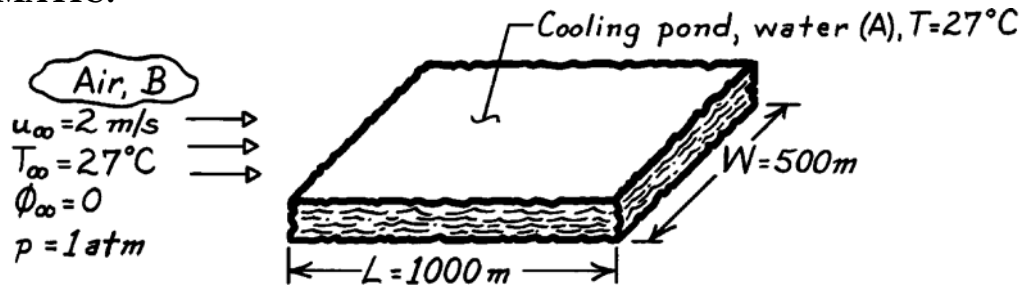

**ASSUMPTIONS:** (1) Steady-state conditions, (2) Turbulent boundary layer over the entire surface, (3) Heat and mass transfer analogy is applicable.

**PROPERTIES:** Table A-4, Air ( $T = 300\text{K}$ , 1 atm):  $\nu = 15.89 \times 10^{-6} \text{ m}^2/\text{s}$ ,  $k = 0.0263 \text{ W/m}\cdot\text{K}$ ,  $\text{Pr} = 0.707$ ; Table A-6, Water vapor (300K):  $\rho_{A,\text{sat}} = \nu_g^{-1} = 0.0256 \text{ kg/m}^3$ ; Table A-8, Water vapor-air (300K):  $D_{AB} = 0.26 \times 10^{-4} \text{ m}^2/\text{s}$ ,  $\text{Sc} = \nu/D_{AB} = 0.61$ .

**ANALYSIS:** The make-up water requirement must equal the daily water loss due to evaporation,

$$\Delta M = \dot{m}_{\text{evap}} \Delta t = \bar{h}_m (W \cdot L) \left[ \rho_{A,\text{sat}}(T_s) - \phi_\infty \rho_{A,\text{sat}}(T_\infty) \right] \cdot \Delta t.$$

From Eq. 7.41 with  $A = 0$ ,  $\bar{\text{Sh}}_L = 0.037 \text{ Re}_L^{4/5} \text{ Sc}^{1/3}$ , with

$$\text{Re}_L = \frac{u_\infty L}{\nu} = \frac{2 \text{ m/s} \times 1000 \text{ m}}{15.89 \times 10^{-6} \text{ m}^2/\text{s}} = 1.26 \times 10^8$$

$$\bar{\text{Sh}}_L = 0.037 \left( 1.26 \times 10^8 \right)^{4/5} (0.61)^{1/3} = 9.48 \times 10^4$$

$$\bar{h}_{m,L} = \frac{D_{AB} \bar{\text{Sh}}_L}{L} = \frac{0.26 \times 10^{-4} \text{ m}^2/\text{s} \times 9.48 \times 10^4}{1000 \text{ m}}$$

$$\bar{h}_{m,L} = 2.47 \times 10^{-3} \text{ m/s}.$$

Hence, the make-up water requirement is

$$\Delta M = 2.47 \times 10^{-3} \text{ m/s} (500 \text{ m} \times 1000 \text{ m}) 0.0256 \text{ kg/m}^3 (24 \text{ h} \times 3600 \text{ s/h})$$

$$\Delta M = 2.73 \times 10^6 \text{ kg/day}.$$

<

## PROBLEM 7.128

**KNOWN:** Dimensions and initial temperature of plate covered by liquid film. Properties of liquid. Velocity and temperature of air flow over the plates.

**FIND:** Initial rate of heat transfer from plate and rate of change of plate temperature.

**SCHEMATIC:**

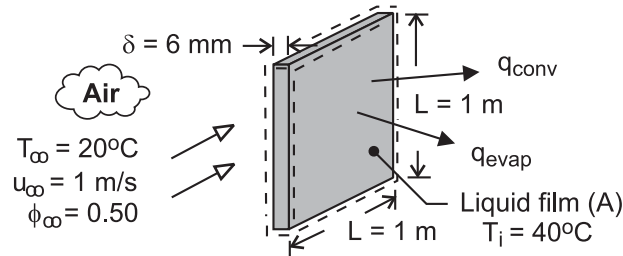

**ASSUMPTIONS:** (1) Negligible effect of conveyor velocity on boundary layer development, (2) Plates are isothermal and at same temperature as liquid film, (3) Negligible heat transfer from sides of plate, (4) Smooth air-liquid interface, (5) Applicability of heat/mass transfer analogy, (6) Negligible solvent vapor in free stream, (7)  $Re_{x,c} = 5 \times 10^5$ , (8) Constant properties.

**PROPERTIES:** Table A-1, AISI 1010 steel (313K):  $c = 441 \text{ J/kg}\cdot\text{K}$ ,  $\rho = 7832 \text{ kg/m}^3$ . Table A-4,

Air ( $p = 1 \text{ atm}$ ,  $T_f = 303\text{K}$ ):  $\nu = 16.2 \times 10^{-6} \text{ m}^2/\text{s}$ ,  $k = 0.0265 \text{ W/m}\cdot\text{K}$ ,  $Pr = 0.707$ . Prescribed: Solvent:  $\rho_{A,\text{sat}} = 0.75 \text{ kg/m}^3$ ,  $D_{AB} = 10^{-5} \text{ m}^2/\text{s}$ ,  $h_{fg} = 9 \times 10^5 \text{ J/kg}$ .

**SOLUTION:** The initial rate of heat transfer from the plate is due to both convection and evaporation.

$$q = q_{\text{conv}} + q_{\text{evap}} = \bar{h} A_s (T_i - T_\infty) + n_A h_{fg} = \bar{h} A_s (T_i - T_\infty) + \bar{h}_m A_s \rho_{A,\text{sat}} h_{fg}$$

With  $Re_L = u_\infty L / \nu = 1 \text{ m/s} \times 1 \text{ m} / 16.2 \times 10^{-6} \text{ m}^2/\text{s} = 6.17 \times 10^4$ , flow is laminar over the entire surface. Hence,

$$\bar{Nu}_L = 0.664 Re_L^{1/2} Pr^{1/3} = 0.664 (6.17 \times 10^4)^{1/2} (0.707)^{1/3} = 147$$

$$\bar{h} = (k/L) \bar{Nu}_L = (0.0265 \text{ W/m}\cdot\text{K} / 1 \text{ m}) 147 = 3.9 \text{ W/m}^2 \cdot \text{K}$$

Also, with  $Sc = \nu / D_{AB} = 16.2 \times 10^{-6} \text{ m}^2/\text{s} / 10^{-5} \text{ m}^2/\text{s} = 1.62$ ,

$$\bar{Sh}_L = 0.664 Re_L^{1/2} Sc^{1/3} = 0.664 (6.17 \times 10^4)^{1/2} (1.62)^{1/3} = 194$$

$$\bar{h}_m = (D_{AB}/L) \bar{Sh}_L = (10^{-5} \text{ m}^2/\text{s} / 1 \text{ m}) 194 = 0.00194 \text{ m/s}$$

Hence, with  $A_s = 2 L^2 = 2 \text{ m}^2$ ,

$$q = 2 \text{ m}^2 \left[ 3.9 \text{ W/m}^2 \cdot \text{K} (20^\circ\text{C}) + 0.00194 \text{ m/s} \times 0.75 \text{ kg/m}^3 \times 9 \times 10^5 \text{ J/kg} \right] = 156 \text{ W} + 2619 \text{ W} = 2775 \text{ W} <$$

Performing an energy balance at an instant of time for a control surface about the plate,  $-\dot{E}_{\text{out}} = \dot{E}_{\text{st}}$ , we obtain (Eq. 5.2),

$$\left. \frac{dT}{dt} \right|_i = -\frac{q}{\rho \delta L^2 c} = -\frac{2775 \text{ W}}{7832 \text{ kg/m}^3 \times 0.006 \text{ m} (1 \text{ m})^2 441 \text{ J/kg}\cdot\text{K}} = -0.13^\circ\text{C/s} <$$

**COMMENTS:** (1) Heat transfer by evaporation exceeds that due to convection by more than an order of magnitude, (2) The total heat rate is small enough to render the lumped capacitance approximation excellent.

### PROBLEM 7.129

**KNOWN:** Dimensions of round jet array. Jet exit velocity and temperature. Temperature of paper.

**FIND:** Drying rate per unit surface area.

**SCHEMATIC:**

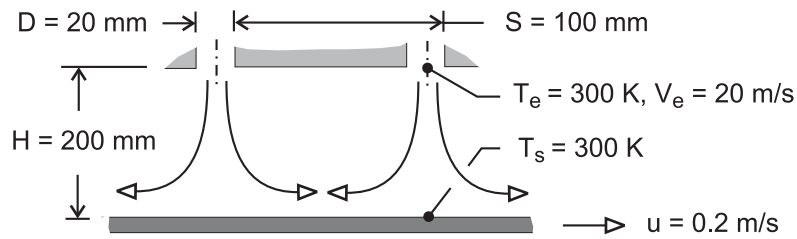

**ASSUMPTIONS:** (1) Applicability of heat and mass transfer analogy. (2) Paper motion has a negligible effect on convection ( $u \ll V_e$ ), (3) Air is dry.

**PROPERTIES:** Table A-4, Air (300K, 1 atm):  $\nu = 15.89 \times 10^{-6} \text{ m}^2/\text{s}$ ; Table A-6, Saturated water (300K):  $\rho_{A,\text{sat}} = \nu_g^{-1} = 0.0256 \text{ kg/m}^3$ ; Table A-8, water vapor-air (300K):  $D_{AB} = 0.26 \times 10^{-4} \text{ m}^2/\text{s}$ ,  $Sc = 0.61$ .

**ANALYSIS:** The average mass evaporation flux is

$$n''_A = \bar{h}_m (\rho_{A,s} - \rho_{A,e}) = \bar{h}_m \rho_{A,s}$$

For an array of round nozzles,

$$\bar{Sh} = 0.5 K G Re^{2/3} Sc^{0.42}$$

where  $Re = V_e D / \nu = 20 \text{ m/s} \times 0.02 \text{ m} / 15.89 \times 10^{-6} \text{ m}^2/\text{s} = 25,170$  and, with  $H/D = 10$  and

$$A_r = \pi D^2 / 4S^2 = 0.0314,$$

$$K = \left[ 1 + \left( \frac{H/D}{0.6/A_r^{1/2}} \right)^6 \right]^{-0.05} = \left[ 1 + \left( \frac{10}{3.39} \right)^6 \right]^{-0.05} = 0.723$$

$$G = 2A_r^{1/2} \frac{1 - 2.2A_r^{1/2}}{1 + 0.2(H/D - 6)A_r^{1/2}} = 0.354 \frac{1 - 0.390}{1 + 0.2(4)0.177} = 0.189$$

Hence,

$$\bar{h}_m = \frac{D_{AB}}{D} \bar{Sh} = \frac{0.26 \times 10^{-4} \text{ m}^2/\text{s}}{0.02 \text{ m}} \left[ 0.5 \times 0.723 \times 0.189 (25,170)^{2/3} (0.61)^{0.42} \right] = 0.062 \text{ m/s}$$

The average evaporative flux is then

$$n''_A = 0.062 \text{ m/s} (0.0256 \text{ kg/m}^3) = 0.0016 \text{ kg/s} \cdot \text{m}^2 \quad <$$

**COMMENTS:** Note that, for maximum evaporation, the ratio  $D/H = 0.1$  is less than the optimum of  $(D/H)_{\text{op}} \approx 0.2$ , as is  $S/H = 0.5$  less than  $(S/H)_{\text{op}} \approx 1.4$ . If  $H$  is reduced by a factor of 2 and  $S$  is increased by 40%, a near optimal condition could be achieved.

## PROBLEM 7.130

**KNOWN:** Paper mill process using radiant heat for drying.

**FIND:** (a) Evaporative flux at a distance 1 m from roll edge; corresponding irradiation,  $G$  ( $\text{W}/\text{m}^2$ ), required to maintain surface at  $T_s = 300$  K, and (b) Compute and plot variations of  $h_{m,x}(x)$ ,  $N''_A(x)$ , and  $G(x)$  for the range  $0 \leq x \leq 1$  m when the velocity and temperature are increased to 10 m/s and 340 K, respectively.

**SCHEMATIC:**

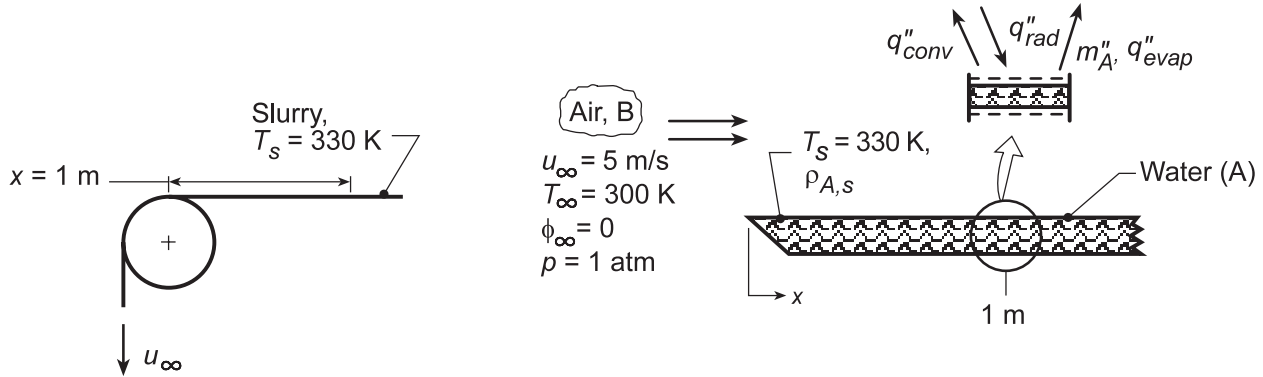

**ASSUMPTIONS:** (1) Steady-state conditions, (2) Heat-mass transfer analogy, (3) Paper slurry (water-fiber mixture) has water properties, (4) Water vapor behaves as perfect gas, (5) All irradiation absorbed by slurry, (6) Negligible emission from the slurry, (7)  $Re_{x,c} = 5 \times 10^5$ .

**PROPERTIES:** Table A.4, Air ( $T_f = 315$  K, 1 atm):  $\nu = 17.40 \times 10^{-6} \text{ m}^2/\text{s}$ ,  $k = 0.0274 \text{ W}/\text{m}\cdot\text{K}$ ,  $Pr = 0.705$ ; Table A.8, Water vapor-air ( $T_f = 315$  K):  $D_{AB} = 0.26 \times 10^{-4} \text{ m}^2/\text{s}$  ( $315/298$ )<sup>3/2</sup> =  $0.28 \times 10^{-4} \text{ m}^2/\text{s}$ ,  $Sc = \nu_B/D_{AB} = 0.616$ ; Table A.6, Saturated water vapor ( $T_s = 330$  K):  $\rho_{A,sat} = 1/\nu_g = 0.1134 \text{ kg}/\text{m}^3$ ,  $h_{fg} = 2366 \text{ kJ}/\text{kg}$ .

**ANALYSIS:** (a) Recognize that the drying process can be modeled as flow over a flat plate with heat and mass transfer. For a unit area at  $x = 1$  m,

$$n''_{A,x} = h_{m,x} (\rho_{A,s} - \rho_{A,\infty}) = h_{m,x} [\rho_{A,sat}(T_s) - \phi_\infty \rho_{A,sat}(T_\infty)] \quad (1)$$

Evaluate  $Re_x$  to determine the nature of flow, select a correlation to estimate  $h_{m,x}$ ,

$$Re_x = u_\infty x / \nu_B = (5 \text{ m/s} \times 1 \text{ m}) / (17.40 \times 10^{-6} \text{ m}^2/\text{s}) = 2.874 \times 10^5.$$

Since  $Re_x < 5 \times 10^5$ , the flow is laminar. Invoking the heat-mass analogy,

$$Sh_x = \frac{h_{m,x} x}{D_{AB}} = 0.332 Re_x^{1/2} Sc^{1/3} \quad (2)$$

$$h_{m,x} = (0.28 \times 10^{-4} \text{ m}^2/\text{s} / 1 \text{ m}) \times 0.332 (2.874 \times 10^5)^{1/2} (0.616)^{1/3} = 4.24 \times 10^{-3} \text{ m/s}.$$

Hence, the evaporative flux at  $x = 1$  m is

$$n''_{A,x} = 4.24 \times 10^{-3} \text{ m/s} (0.1134 \text{ kg}/\text{m}^3 - 0) = 4.81 \times 10^{-4} \text{ kg}/\text{s} \cdot \text{m}^2 <$$

From an energy balance on the differential element at  $x = 1$  m (see above),

$$G = q''_{conv} + q''_{evap} = h_x (T_s - T_\infty) + n''_{A,x} h_{fg}. \quad (3)$$

Continued...

### PROBLEM 7.130 (Cont.)

To estimate  $h_x$ , invoke the heat-mass transfer analogy using the correlation of Eq. (2),

$$h_x = h_{m,x} \frac{k}{D_{AB}} \left( \frac{Pr}{Sc} \right)^{1/3} = 4.24 \times 10^{-3} \text{ m/s} \left( \frac{0.0274 \text{ W/m} \cdot \text{K}}{0.28 \times 10^{-4} \text{ m}^2/\text{s}} \right) \left( \frac{0.705}{0.616} \right)^{1/3} = 4.34 \text{ W/m}^2 \cdot \text{K} \quad (4)$$

Hence, from Eq. (3), the radiant power required to maintain the slurry at  $T_s = 330 \text{ K}$  is

$$G = 4.34 \text{ W/m}^2 \cdot \text{K} (330 - 300) \text{ K} + 4.81 \times 10^{-4} \text{ kg/s} \cdot \text{m}^2 \times 2366 \times 10^3 \text{ J/kg}$$

$$G = (130 + 1138) \text{ W/m}^2 = 1268 \text{ W/m}^2 .$$

<

(b) Equations (1), (3) and (4) were entered into the *IHT Workspace*. The *Correlations Tool, External Flow, Local coefficients for Laminar or Turbulent Flow* was used to estimate the heat transfer convection coefficient. The results for  $h_{m,x}(x)$ ,  $n''_{A,x}(x)$  and  $G(x)$  were evaluated, and are plotted below for  $T_s = 340 \text{ K}$  and  $u_\infty = 10 \text{ m/s}$ .

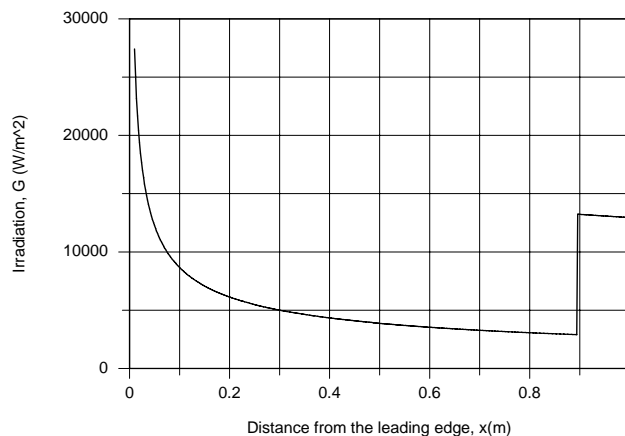
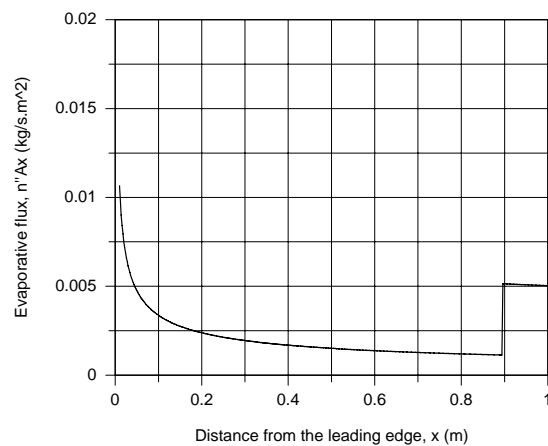
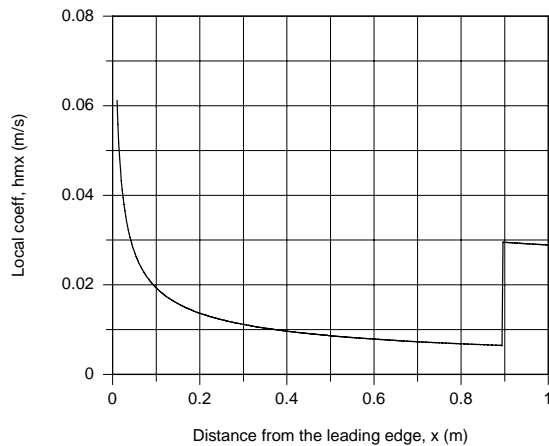

**COMMENTS:** (1) The abrupt change in the parameter plots occurs at the transition,  $x_c = 0.9 \text{ m}$ .

### PROBLEM 7.131

**KNOWN:** Geometry and air flow conditions for a water storage channel.

**FIND:** (a) Evaporation rate, (b) Expression for rate of change of water layer depth and time required for complete evaporation.

**SCHEMATIC:**

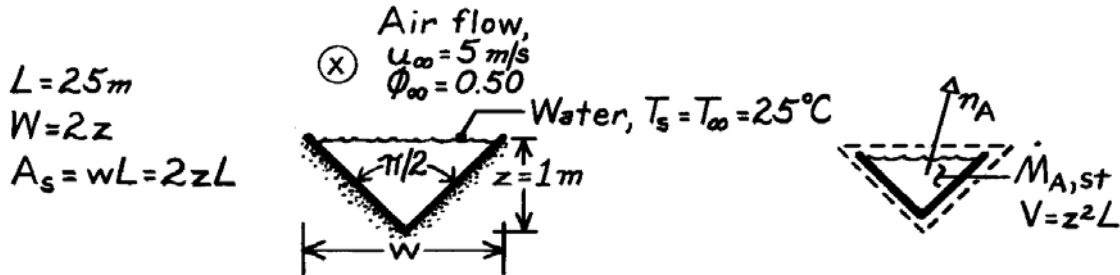

**ASSUMPTIONS:** (1) Steady-state conditions, (2) Smooth water surface and negligible free stream turbulence, (3) Heat and mass transfer analogy is applicable, (4)  $Re_{x,c} = 5 \times 10^5$ , (5) Perfect gas behavior for water vapor.

**PROPERTIES:** Table A-4 Air ( $25^\circ\text{C} = 298\text{K}$ ):  $\nu = 15.71 \times 10^{-6} \text{ m}^2/\text{s}$ ; Table A-6, Water ( $25^\circ\text{C} = 298\text{K}$ ):  $\rho_{A,sat} = \nu_g^{-1} = 0.0226 \text{ kg/m}^3$ ,  $\rho_f = \nu_f^{-1} = 997 \text{ kg/m}^3$ ; Table A-8, Water vapor-air ( $25^\circ\text{C} = 298\text{K}$ ):  $D_{AB} = 0.26 \times 10^{-4} \text{ m}^2/\text{s}$ ,  $Sc = \nu/D_{AB} = 0.60$ .

**ANALYSIS:** (a) The evaporation rate is  $n_A = \bar{h}_m A_s (\rho_{A,sat} - \rho_{A,\infty}) = \bar{h}_m (w \times L) \rho_{A,sat} (1 - \phi_\infty)$ . With

$$Re_L = u_\infty L / \nu = 5 \text{ m/s} \times 25 \text{ m} / 15.71 \times 10^{-6} \text{ m}^2/\text{s} = 7.96 \times 10^6$$

$$\text{Eq. 7.42 yields } \bar{Sh}_L = \left[ 0.037 (7.96 \times 10^6)^{4/5} - 871 \right] (0.6)^{1/3} = 9616$$

$$\bar{h}_m = 9616 D_{AB} / L = 9616 \times 0.26 \times 10^{-4} \text{ m}^2/\text{s} / (25 \text{ m}) = 0.010 \text{ m/s.}$$

With  $w = 2z = 2\text{ m}$ ,

$$n_A = 0.01 \text{ m/s} (2\text{ m} \times 25\text{ m}) 0.0226 \text{ kg/m}^3 (0.5) = 0.00565 \text{ kg/s} = 20.3 \text{ kg/h.} \quad <$$

(b) Performing a mass balance on a control volume about the water,

$$-n_A = \dot{m}_{A,st} = \frac{d}{dt} (\rho_f V) \quad -\bar{h}_m (2zL) \rho_{A,sat} (1 - \phi_\infty) = \frac{d}{dt} (\rho_f z^2 L)$$

$$\frac{dz}{dt} = -\bar{h}_m \frac{\rho_{A,sat}}{\rho_f} (1 - \phi_\infty).$$

$$\text{Integrating, } \int_z^0 dz = -\bar{h}_m \frac{\rho_{A,sat}}{\rho_f} (1 - \phi_\infty) \int_0^t dt$$

$$t = \frac{z \rho_f}{\bar{h}_m \rho_{A,sat}} \frac{1}{1 - \phi_\infty} = \frac{1 \text{ m} \times 997 \text{ kg/m}^3}{0.01 \text{ m/s} \times 0.0226 \text{ kg/m}^3 (1 - 0.5)} = 8.82 \times 10^6 \text{ s} = 2451 \text{ h} = 102 \text{ d.} \quad <$$

**COMMENTS:** Although the evaporation rate decreases with increasing time due to decreasing  $A_s$ ,  $dz/dt$  remains constant and the water depth decreases linearly.

### PROBLEM 7.132

**KNOWN:** Mass change for a given time period of a solid naphthalene cylinder subjected to cross flow of air for prescribed conditions.

**FIND:** (a) Mass transfer coefficient,  $\bar{h}_m$ , based upon experimental observations and (b)  $\bar{h}_m$  based upon appropriate correlation.

**SCHEMATIC:**

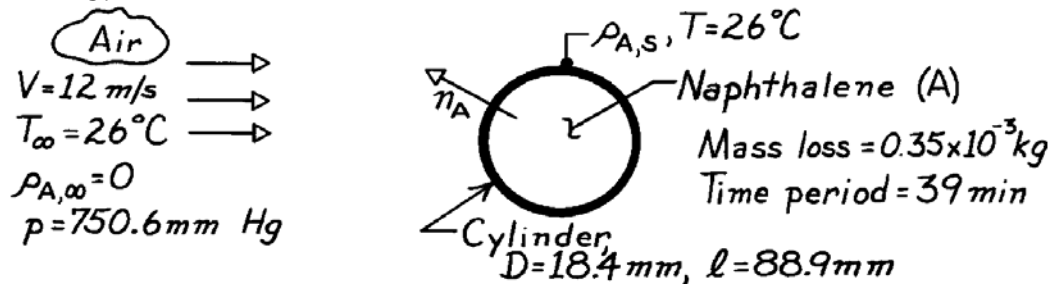

**ASSUMPTIONS:** (1) Steady-state conditions, (2) Negligible naphthalene vapor in free stream, (3) Heat-mass transfer analogy applies.

**PROPERTIES:** Table A-4, Air (299K, 1 atm):  $\nu = 15.80 \times 10^{-6} \text{ m}^2/\text{s}$ ; Table A-6, Naphthalene vapor-air (298K, 1 atm):  $D_{AB} = 0.62 \times 10^{-5} \text{ m}^2/\text{s}$ ; Naphthalene (given):  $\mathcal{M} = 128.16 \text{ kg/kmol}$ ,  $p_{\text{sat}} = p \times 10^E$  where  $E = 8.67 - (3766/T)$  with  $p[\text{bar}]$  and  $T[\text{K}]$ .

**ANALYSIS:** (a) The rate equation for the sublimation of naphthalene vapor from the solid naphthalene can be written in terms of the mass transfer coefficient.

$$\bar{h}_m = \frac{n_A}{A_s (\rho_{A,s} - \rho_{A,\infty})} \quad (1)$$

where  $A_s = \pi D \ell$ . From the mass loss and time observations

$$n_A = \frac{\Delta m}{\Delta t} = \frac{0.35 \times 10^{-3} \text{ kg}}{39 \times 60 \text{ s}} = 1.50 \times 10^{-7} \text{ kg/s.}$$

The saturation density of the vapor at the solid surface,  $\rho_{A,s}$ , can be determined from the perfect gas relation,

$$\rho_{A,s} = C_{A,s} \mathcal{M}_A = \frac{p_{\text{sat}}(T_s)}{(\mathcal{R}/\mathcal{M}_A) T_s} \quad (2)$$

The saturation pressure,  $p_{\text{sat}}$ , is given by

$$p_{\text{sat}} = p \times 10^E \quad (3)$$

where  $E = 8.67 - (3766/T) = 8.67 - (3766/299\text{K}) = -3.925$

$$p = 750.6 \text{ mm Hg} \times \frac{1 \text{ N/m}^2}{2.953 \times 10^{-4} \text{ in Hg}} \times \frac{1 \text{ in}}{25.4 \text{ mm}} \times \frac{1 \text{ bar}}{1 \times 10^5 \text{ N/m}^2} = 1.001 \text{ bar}$$

or 
$$p_{\text{sat}} = 1.001 \text{ bar} \times 10^{-3.925} = 1.190 \times 10^{-4} \text{ bar.}$$

Continued ...

### PROBLEM 7.132 (Cont.)

Substituting into Eq. (2),

$$\rho_{A,s} = 1.190 \times 10^{-4} \text{ bar} / \frac{8.314 \times 10^{-2} \text{ m}^3 \cdot \text{bar/kmol} \cdot \text{K}}{128.16 \text{ kg/kmol}} \times 299 \text{ K} = 6.135 \times 10^{-4} \text{ kg/m}^3.$$

Using the parameters required for Eq. (1), the mass transfer coefficient is

$$\bar{h}_m = \frac{1.50 \times 10^{-7} \text{ kg/s}}{\pi (18.4 \times 10^{-3} \text{ m}) (88.9 \times 10^{-3} \text{ m})} [6.135 \times 10^{-4} - 0] \text{ kg/m}^3$$

$$\bar{h}_m = 4.76 \times 10^{-2} \text{ m/s.} \quad <$$

(b) Invoking the heat-mass transfer analogy and assuming a Prandtl number ratio of unity, Eq. 7.53 can be used to estimate  $\bar{h}_m$ ,

$$\overline{\text{Sh}}_D = \frac{\bar{h}_m D}{D_{AB}} = C \text{Re}_D^m \text{Sc}^n.$$

With

$$\text{Re}_D = \frac{VD}{\nu} = 12 \text{ m/s} (18.4 \times 10^{-3} \text{ m}) / 15.80 \times 10^{-6} \text{ m}^2/\text{s} = 13,975$$

it follows from Table 7.4 that  $C = 0.26$  and  $m = 0.6$ . With

$$\text{Sc} = \nu/D_{AB} = 15.80 \times 10^{-6} \text{ m}^2/\text{s} / 0.62 \times 10^{-5} \text{ m}^2/\text{s} = 2.55$$

$$n = 0.37 \text{ and}$$

$$\overline{\text{Sh}}_D = 0.26 (13,975)^{0.6} (2.55)^{0.37} = 112.9$$

and

$$\bar{h}_m = \overline{\text{Sh}}_D \frac{D_{AB}}{D} = 112.9 \times \frac{0.62 \times 10^{-5} \text{ m}^2/\text{s}}{18.4 \times 10^{-3} \text{ m}} = 3.80 \times 10^{-2} \text{ m/s.} \quad <$$

**COMMENTS:** The result from the correlation is 20% less than the experimental result. This may be considered reasonable in view of the uncertainties associated with the observations and the approximate nature of the correlation.



### PROBLEM 7.133

**KNOWN:** Flow of dry air over a cylindrical medium saturated with water.

**FIND:** (a) Mass rate of water vapor evaporated per unit length  $n'_A$ , when water-air is at 300 K, (b) Briefly explain change in mass rate if temperatures are at 325 K.

**SCHEMATIC:**

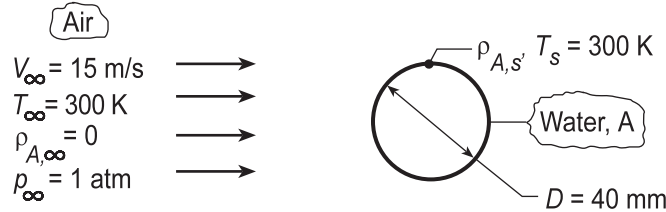

**ASSUMPTIONS:** (1) Steady-state conditions, (2) Heat-mass transfer analogy.

**PROPERTIES:** Table A.4, Air (300 K, 1 atm):  $\nu = 15.89 \times 10^{-6} \text{ m}^2/\text{s}$ ,  $\text{Pr} = 0.707$ ; Air (325 K, 1 atm):  $\nu = 18.41 \times 10^{-6} \text{ m}^2/\text{s}$ ,  $\text{Pr} = 0.703$ ; Table A.8, Water vapor-air (300 K):  $D_{AB} = 0.26 \times 10^{-4} \text{ m}^2/\text{s}$ ; Table A.6, Water vapor (300 K, 1 atm):  $\rho_{A,\text{sat}} = (\nu_g)^{-1} = (39.13 \text{ m}^3/\text{kg})^{-1} = 0.0256 \text{ kg/m}^3$ ; Water vapor (325 K, 1 atm):  $\rho_{A,\text{sat}} = (\nu_g)^{-1} = (11.06 \text{ m}^3/\text{kg})^{-1} = 0.0904 \text{ kg/m}^3$ .

**ANALYSIS:** (a) For cross-flow over a cylinder, Eq. 7.52,

$$\overline{\text{Sh}}_D = C \text{Re}^m \text{Sc}^{1/3} \quad (1)$$

where  $m, n$  are taken from Table 7.2. Calculate the Reynolds number,  $\text{Re}_D = VD/\nu = 15 \text{ m/s} \times 0.04 \text{ m} / 15.89 \times 10^{-6} \text{ m}^2/\text{s} = 37,760$ . With  $C = 0.193$ ,  $m = 0.618$ , and  $\text{Sc} \equiv \nu/D_{AB}$ ,

$$\overline{\text{Sh}}_D = \frac{\bar{h}_m D}{D_{AB}} = 0.193 (37,760)^{0.618} \left[ 15.89 \times 10^{-6} \text{ m}^2/\text{s} / 0.26 \times 10^{-4} \text{ m}^2/\text{s} \right]^{1/3} = 110.4 \quad (2)$$

$$\bar{h}_m = \overline{\text{Sh}}_D D_{AB} / D = 110.4 \times 0.26 \times 10^{-4} \text{ m}^2/\text{s} / 0.04 \text{ m} = 0.0717 \text{ m/s}$$

The evaporation rate, with  $A_s = \pi D \cdot \ell$ , is

$$n_A = \bar{h}_m A_s (\rho_{A,s} - \rho_{A,\infty}) \quad n'_A = n_A / \ell = \bar{h}_m \pi D (\rho_{A,s} - \rho_{A,\infty}) \quad (3)$$

$$n'_A = 0.0717 \text{ m/s} (\pi \times 0.04 \text{ m}) (0.0256 - 0) \text{ kg/m}^3 = 2.31 \times 10^{-4} \text{ kg/s} \cdot \text{m} \quad <$$

(b) The foregoing equations were entered into the *IHT Workspace*, and using the *Properties Tools* for air and water vapor thermophysical properties, the evaporation rate  $n'_A$  was calculated as a function of air-water temperatures ( $T_s = T_{\text{inf}}$ ).

Continued...

## PROBLEM 7.133 (Cont.)

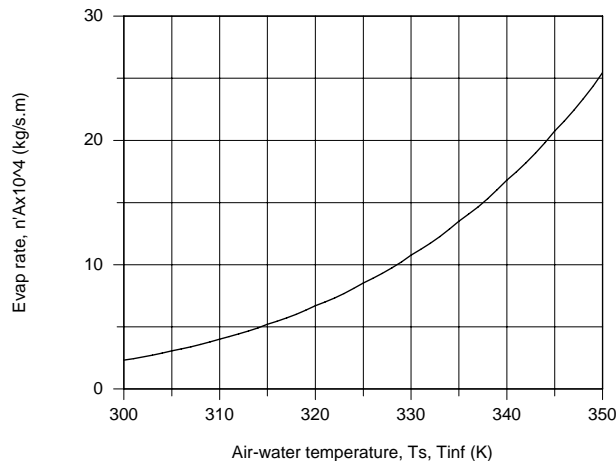

As expected, the evaporation rate increased with increasing temperature markedly. For a 50 K increase, the evaporation rate increased by a factor of approximately 12.

**COMMENTS:** (1) What parameters cause this high sensitivity of  $n'_A$  to  $T_s$ ? From the IHT analysis, we observed only modest changes in  $D_{AB}$  ( $0.26$  to  $0.33 \times 10^{-4}$  m<sup>2</sup>/s) and  $\bar{h}_m$  ( $0.07273$  to  $0.0779$  m/s) over the range 300 to 350 K. The density of water vapor,  $\rho_{A,s}$ , however, is highly temperature dependent as can be seen by examining the steam tables, Table A.6. Find  $\rho_{A,s}$  (300 K) =  $0.02556$  kg/m<sup>3</sup> while  $\rho_{A,s}$  (350 K) =  $0.260$  kg/m<sup>3</sup>, which accounts for more than a factor of 10 change.

(2) A copy of the IHT Workspace used to perform the analysis is shown below.

```
// The Mass Transfer Rate Equation:
n'A = hmbars * pi * D * (rhoAs - 0) // Eq (3)
n'A_plot = 1e4 * n'A // Scale change for plotting

// Mass Transfer Coefficient Correlation:
ShDbar = C * ReD^m * Sc^(1/3) // Eq (1,2)
ShDbar = hmbars * D / DAB
C = 0.193 // Table 7.2, 4000 <= ReD <= 40000
m = 0.618
ReD = uinf * D / nu
Sc = nu / DAB

// Properties Tool - Water Vapor:
// Water property functions :T dependence, From Table A.6
// Units: T(K), p(bars);
xs = 1 // Quality (0=sat liquid or 1=sat vapor)
rhoAs = rho_Tx("Water",Ts,xs) // Density, kg/m^3

// Properties Tool - Air:
// Air property functions : From Table A.4
// Units: T(K); 1 atm pressure
nu = nu_T("Air",Tf) // Kinematic viscosity, m^2/s

// Properties, Table A.8, Water Vapor - Air:
DAB = 0.26e-4 * (Tf / 298)^1.5 // Table A.8
Tf = (Ts + Tinf) / 2

// Assigned Variables:
Ts = 300 // Surface temperature, K
D = 0.040 // Diameter, m
uinf = 15 // Airstream velocity, m/s
Tinf = Ts // Airstream temperature, K
```

**PROBLEM 7.134**

**KNOWN:** Dry air at prescribed temperature and velocity flowing over a long, wetted cylinder of diameter 20 mm. Embedded electrical heater maintains the surface at  $T_s = 20^\circ\text{C}$ .

**FIND:** (a) Water evaporation rate per unit length (kg/h-m) and electrical power per unit length  $P'_e$  (W/m) required to maintain steady-state conditions, and (b) The temperature of the cylinder after all the water has evaporated for the same airstream conditions and heater power of part (a).

**SCHEMATIC:**

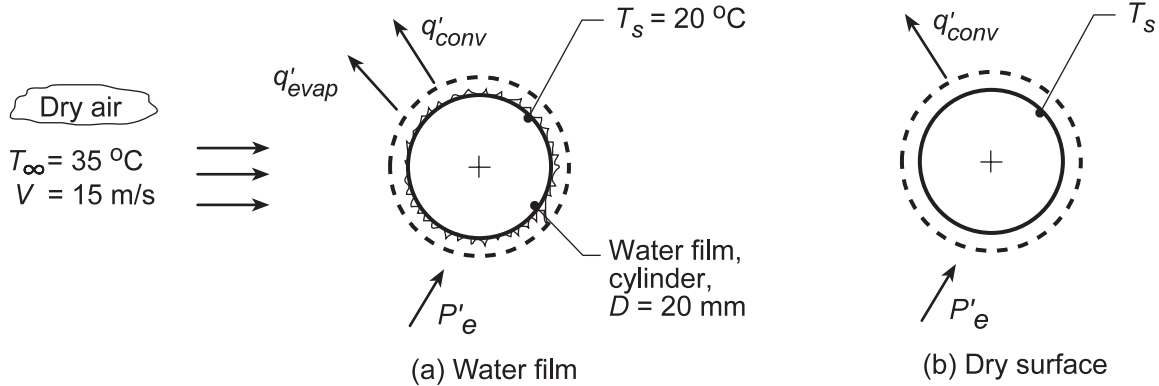

**ASSUMPTIONS:** (1) Steady-state conditions, (2) Constant properties and (3) Heat-mass transfer analogy is applicable.

**PROPERTIES:** Table A.4, Air ( $T_f = (T_s + T_\infty)/2 = 300\text{ K}$ , 1 atm):  $\rho = 1.16\text{ kg/m}^3$ ,  $c_p = 1007\text{ J/kg}\cdot\text{K}$ ,  $k = 0.0263\text{ W/m}\cdot\text{K}$ ,  $\nu = 15.94 \times 10^{-6}\text{ m}^2/\text{s}$ ,  $\alpha = 2.257 \times 10^{-5}\text{ m}^2/\text{s}$ ,  $\text{Pr} = 0.707$ . Table A.6, Water ( $T_s = 20^\circ\text{C} = 293\text{ K}$ ):  $\rho_{A,s} = 1/\nu_g = 1/59.04 = 0.0169\text{ kg/m}^3$ ,  $h_{fg} = 2454\text{ kJ/K}$ ; Table A.8, Water-air ( $T_f = 300\text{ K}$ ):  $D_{AB} = 0.26 \times 10^{-4}\text{ m}^2/\text{s}$ .

**ANALYSIS:** (a) Perform an energy balance on the cylinder,

$$\dot{E}_{in} - \dot{E}_{out} = 0 \quad P'_e - q'_{conv} - q'_{evap} = 0 \quad (1)$$

where the convection and evaporation rate equations are,

$$q'_{conv} = \bar{h}_D \pi D (T_s - T_\infty) \quad (2)$$

$$q_{evap} = n_A h_{fg} = \bar{h}_m \pi D (\rho_{A,s} - \rho_{A,\infty}) h_{fg} \quad (3)$$

The convection coefficient can be estimated from the Churchill-Bernstein correlation, Eq. 7.54,

$$\bar{Nu}_D = 0.3 + \frac{0.62 \text{Re}_D^{1/2} \text{Pr}^{1/3}}{\left[1 + (0.4/\text{Pr})^{2/3}\right]^{1/4}} \left[1 + \left(\frac{\text{Re}_D}{282,000}\right)^{5/8}\right]^{4/5}$$

$$\text{Re}_D = \frac{VD}{\nu} = \frac{15\text{ m/s} \times 0.020\text{ m}}{15.94 \times 10^{-6}\text{ m}^2/\text{s}} = 18,821$$

$$\bar{Nu}_D = 0.3 + \frac{0.62(18,821)^{1/2} (0.707)^{1/3}}{\left[1 + (0.4/0.707)^{2/3}\right]^{1/4}} \left[1 + \left(\frac{18,821}{282,000}\right)^{5/8}\right]^{4/5} = 76.5$$

$$\bar{h}_D = \frac{k}{D} \bar{Nu}_D = \frac{0.0263\text{ W/m}\cdot\text{K}}{0.020\text{ m}} \times 76.5 = 101\text{ W/m}^2\cdot\text{K}$$

Continued...

**PROBLEM 7.134 (Cont.)**

Invoking the heat-mass analogy, Chapter 6, with  $n = 1/3$

$$\frac{\bar{h}_D}{\bar{h}_m} = \rho c_p \left( \frac{\alpha}{D_{AB}} \right)^{2/3} = 1.16 \text{ kg/m}^3 \times 1007 \text{ J/kg} \cdot \text{K} \left( \frac{2.257 \times 10^{-5} \text{ m}^2/\text{s}}{0.26 \times 10^{-4} \text{ m}^2/\text{s}} \right)^{2/3} = 1063 \text{ J/m}^3 \cdot \text{K}$$

$$\bar{h}_m = 101 \text{ W/m}^2 \cdot \text{K} / 1063 \text{ J/m}^3 \cdot \text{K} = 0.095 \text{ m/s}$$

Substituting numerical values, the energy balance, Eq. (1),

$$P_e - 101 \text{ W/m}^2 \cdot \text{K} \times \pi \times 0.020 \text{ m} (20 - 35) \text{ K} \\ - 0.095 \text{ m/s} \times \pi \times 0.020 \text{ m} (0.0169 - 0) \text{ kg/m}^3 \times 2454 \times 10^3 \text{ J/kg} \cdot \text{K} = 0$$

$$P_e = -95.1 \text{ W/m} + 247 \text{ W/m} = 152 \text{ W/m} \quad <$$

The evaporation rate is

$$n_A = \bar{h}_m \pi D (\rho_{A,s} - \rho_{A,\infty}) = 0.095 \text{ m/s} \pi \times 0.020 \text{ m} (0.0169 - 0) \text{ kg/m}^3 = 0.362 \text{ kg/h} \cdot \text{m} \quad <$$

(b) When the cylinder is dry, the energy balance is

$$P'_e = \bar{h}_D \pi D (T_s - T_\infty)$$

$$T_s = T_\infty + P'_e / \bar{h}_D \pi D = 35^\circ \text{C} + 152 \text{ W/m} / \left( 101 \text{ W/m}^2 \cdot \text{K} \pi \times 0.020 \text{ m} \right) = 58.9^\circ \text{C} \quad <$$

**COMMENTS:** Using *IHT Correlations Tool, External Flow, Cylinder*, the calculation of part (b) was performed using the proper film temperature,  $T_f = 316.8 \text{ K}$ , to find  $\bar{h}_D = 99.4 \text{ W/m}^2 \cdot \text{K}$  and  $T_s = 52.6^\circ \text{C}$ .

## PROBLEM 7.135

**KNOWN:** Dry air at prescribed temperature and velocity flows over a rod covered with a thin porous coating saturated with water. The ends of the rod are attached to heat sinks maintained at a constant temperature.

**FIND:** Temperature at the midspan of the rod and evaporation rate from the surface using a steady-state, finite-difference analysis. Validate your code, without the evaporation process, by comparing the temperature distribution with the analytical solution of a fin.

**SCHEMATIC:**

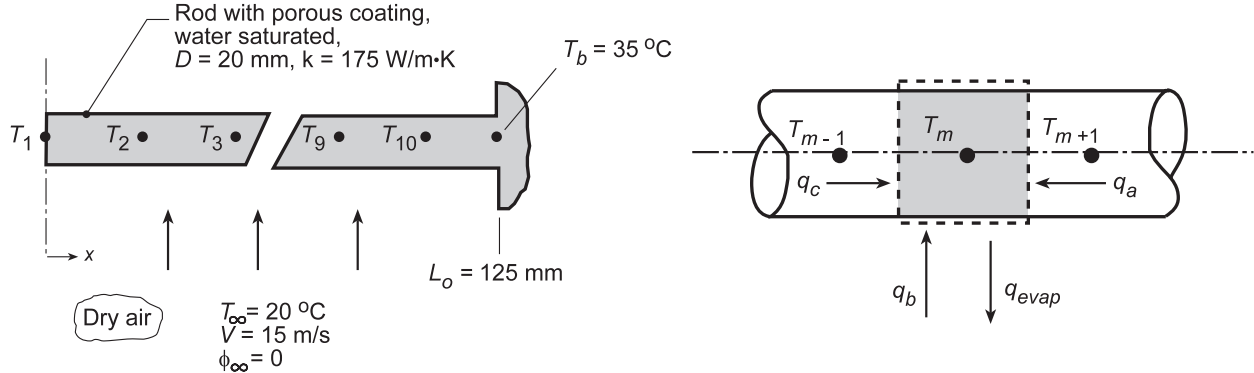

**ASSUMPTIONS:** (1) Steady-state conditions, (2) One-dimensional conduction in rod, (3) Constant properties, and (4) Heat-mass transfer analogy is applicable.

**PROPERTIES:** Table A.4, Air ( $\bar{T}_f$ , see Eq. (2); 1 atm):  $\rho$ ,  $c_p$ ,  $k$ ,  $\alpha$ , Pr; Table A.6, Water ( $T_m = T_{\text{sat},m}$ , 1 atm):  $\rho_{A,\text{sat}} = 1/v_g$ ,  $h_{fg}$ ; Table A.8, Water Vapor-Air ( $\bar{T}_f$ , 1 atm):  $D_{AB} = D_{AB}(298 \text{ K}) \times (\bar{T}_f / 298)^{1.5}$ .

**ANALYSIS:** As suggested, the 10-node network shown above represents the half-length of the system. Performing an energy balance on the control volume about the  $m$ -th node, the finite-difference equation for the system is derived.

$$\dot{E}_{\text{in}} - \dot{E}_{\text{out}} = 0$$

$$q_a - q_{\text{evap}} + q_b + q_c = 0$$

$$kA_c \frac{T_{m+1} - T_m}{\Delta x} - n_{A,m} h_{fg,m} + \bar{h} P \Delta x (T_\infty - T_m) + kA_c \frac{T_{m-1} - T_m}{\Delta x} = 0 \quad (1)$$

where the cross-sectional area and perimeter are  $A_c = \pi D^2/4$  and  $P = \pi D$ , respectively. The average heat transfer coefficient  $\bar{h}$  can be evaluated using the Churchill-Bernstein correlation, Eq. 7.54, evaluating thermophysical properties at an average film temperature for the system,

$$\bar{T}_f = [(T_1 + T_b)/2 + T_\infty]/2 \quad (2)$$

The evaporation rate from Eq. (1) can be expressed as

$$n_{A,m} = \bar{h}_{D,m} P \Delta x (\rho_{A,s,m} - 0) \quad (3)$$

where  $\bar{h}_{D,m}$  can be determined from the heat-mass analogy, Eq. 6.60, with  $n = 1/3$ ,

$$\frac{\bar{h}}{\bar{h}_m} = \rho c_p \left( \frac{\alpha}{D_{AB}} \right)^{-2/3} \quad (4)$$

Continued...

## PROBLEM 7.135 (Cont.)

where all properties are evaluated at  $\bar{T}_f$ . The density of water vapor,  $\rho_{A,s,m}$ , as well as the heat of vaporization,  $h_{fg,m}$ , must be evaluated at the nodal temperature  $T_m$ .

Using the *IHT Correlation Tool, External Flow, Cylinder*, an estimate of  $\bar{h}_D = 101 \text{ W/m}^2\cdot\text{K}$  was obtained with  $\bar{T}_f = 298.5 \text{ K}$  (based upon assumed value of  $T_1 = 27^\circ\text{C}$ ). From the analogy, Eq. (4), find that  $\bar{h}_{D,m} = 0.0772 \text{ m/s}$ . Using the *IHT Workspace*, the finite-difference equations, Eq. (1), were entered and the temperature distribution (K, Case 1) determined as tabulated below. Using this same code with  $\bar{h}_{D,m} = 1.0 \times 10^{-10} \text{ m/s}$ , the temperature distribution (K, Case 2) was obtained. The results compared identically with the analytical solution for a fin with an adiabatic tip using the *IHT Model, Extended Surface, Rectangular Pin Fin*.

Case	$T_1$	$T_2$	$T_3$	$T_4$	$T_5$	$T_6$	$T_7$	$T_8$	$T_9$	$T_{10}$	$T_b$
1	287	287.2	287.6	288.3	289.4	290.9	292.9	295.4	298.6	302.7	308
2	300.3	300.4	300.6	300.9	301.4	302.1	302.8	303.8	305	306.4	308

The evaporation rate obtained by summing rates from each nodal element including node b is

$$n_{A,\text{tot}} = 1.08 \times 10^{-5} \text{ kg/s}$$

**COMMENTS:** A copy of the *IHT Workspace* used to perform the above analysis is shown below.

```
// Nodal finite-difference equations (Only Nodes 1, 2 and 10 shown):
k * Ac * (T2 - T1) / delx - mdot1 * hfg1 + hbar * P * delx * (Tinf - T1) + k * Ac * (T2 - T1) / delx = 0
mdot1 = hbar * P * delx * rhoA1
k * Ac * (T3 - T2) / delx - mdot2 * hfg2 + hbar * P * delx * (Tinf - T2) + k * Ac * (T1 - T2) / delx = 0
mdot2 = hbar * P * delx * rhoA2
.....
.....
k * Ac * (Tb - T10) / delx - mdot10 * hfg10 + hbar * P * delx * (Tinf - T10) + k * Ac * (T9 - T10) / delx = 0
mdot10 = hbar * P * delx * rhoA10

// Evaporation Rate:
mtot = mdot1/2 + mdot2 + mdot3 + mdot4 + mdot5 + mdot6 + mdot7 + mdot8 + mdot9 + mdot10 + mdotb
mdotb = hbar * P * delx/2 * rhoAb

// Properties Tool - Water Vapor, rhoAm and hfgm
// Water property functions :T dependence, From Table A.6
// Units: T(K), p(bars);
x = 1 // Quality (0=sat liquid or 1=sat vapor)
rhoA1 = rho_Tx("Water",T1,x) // Density, kg/m^3
hfg1 = hfg_T("Water",T1) // Heat of vaporization, J/kg
rhoA2 = rho_Tx("Water",T2,x) // Density, kg/m^3
hfg2 = hfg_T("Water",T2) // Heat of vaporization, J/kg
.....
.....
rhoA10 = rho_Tx("Water",T10,x) // Density, kg/m^3
hfg10 = hfg_T("Water",T10) // Heat of vaporization, J/kg
rhoAb = rho_Tx("Water",Tb,x) // Density, kg/m^3
hfgb = hfg_T("Water",Tb) // Heat of vaporization, J/kg

// Assigned Variables
Ac = pi * D^2 / 4 // Cross-sectional area, m^2
P = pi * D // Perimeter, m
D = 0.020 // Diameter, m
delx = 0.125 / 10 // Spatial increment, m
k = 175 // Thermal conductivity, W/m.K
Tb = 35 + 273 // Base temperature, K
Tinf = 20 + 273 // Fluid temperature, K
hbar = 0.07719 // Average mass transfer coefficient, m/s
hbar = 101 // Average heat transfer coefficient, W/m^2.K
```

### PROBLEM 7.136

**KNOWN:** The dimensions of a cylinder which approximates the human body.

**FIND:** (a) Heat loss by forced convection to ambient air, (b) Total heat loss when a water film covers the surface.

**SCHEMATIC:**

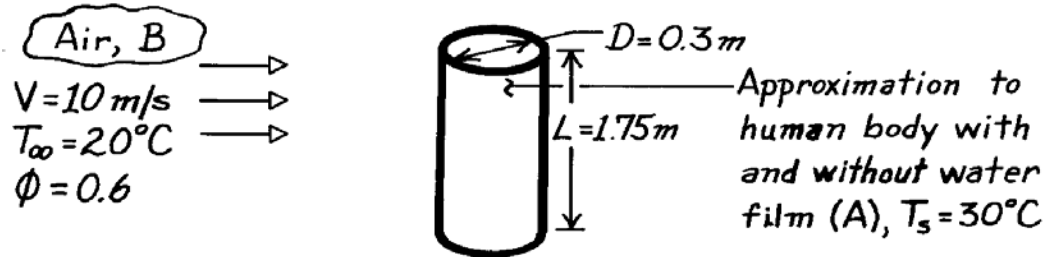

**ASSUMPTIONS:** (1) Direct contact between skin and air (no clothing), (2) Negligible radiation effects, (3) Heat and mass transfer analogy is applicable, (4) Water vapor is an ideal gas.

**PROPERTIES:** Table A-6, Water (30°C = 303 K):  $\rho_{A,\text{sat}} = v_g^{-1} = 0.0336 \text{ kg/m}^3$ ,  $h_{fg} = 2431 \text{ kJ/kg}$ ;  
 Water (20°C = 293K):  $\rho_{A,\text{sat}} = 0.017 \text{ kg/m}^3$ ; Table A-4, Air: ( $T_\infty = 20^\circ\text{C} = 293\text{K}$ ):  $\nu = 15.27 \times 10^{-6} \text{ m}^2/\text{s}$ ,  $k = 25.7 \times 10^{-3} \text{ W/m}\cdot\text{K}$ ,  $\text{Pr} = 0.71$ ; Table A-8, Water vapor-air (300K):  $D_{AB} = 26 \times 10^{-6} \text{ m}^2/\text{s}$ ,  
 $\text{Sc} = \nu/D_{AB} = 0.59$ .

**ANALYSIS:** (a) The heat rate is

$$q = \bar{h}(\pi DL) (T_s - T_\infty).$$

With

$$\text{Re}_D = \frac{VD}{\nu} = \frac{(10 \text{ m/s})(0.3 \text{ m})}{15.27 \times 10^{-6} \text{ m}^2/\text{s}} = 1.96 \times 10^5$$

obtain  $\bar{h}$  from Eq. 7.53, where  $n = 0.37$  and, from Table 7.4,  $C = 0.26$  and  $m = 0.6$ ,

$$\overline{\text{Nu}}_D = 0.6 \left( 1.96 \times 10^5 \right)^{0.6} (0.71)^{0.37} (0.71/0.71)^{0.25} = 343.$$

$$\text{Hence } \bar{h} = \overline{\text{Nu}}_D \frac{k}{D} = 343 \times \frac{25.7 \times 10^{-3} \text{ W/m}\cdot\text{K}}{0.3 \text{ m}} = 29.4 \text{ W/m}^2 \cdot \text{K}$$

$$\text{and } q = 29.4 \text{ W/m}^2 \cdot \text{K} (\pi \times 0.3 \text{ m} \times 1.75 \text{ m}) (30 - 20)^\circ\text{C} = 485 \text{ W.} \quad \leftarrow$$

(b) The total heat loss with the water film includes latent, as well as sensible, contributions and may be expressed as

$$q = \bar{h}(\pi DL) (T_s - T_\infty) + \dot{n}_A h_{fg}$$

$$\text{where } \dot{n}_A = \bar{h}_m (\pi DL) \left[ \rho_{A,\text{sat}}(T_s) - \rho_{A,\infty} \right]$$

$$\rho_{A,\text{sat}}(T_s) = 0.0336 \text{ kg/m}^3 \quad \rho_{A,\infty} \approx \phi \rho_{A,\text{sat}}(T_\infty) = 0.6(0.017) = 0.010 \text{ kg/m}^3.$$

Continued ...

### PROBLEM 7.136 (Cont.)

The convection mass transfer coefficient may be obtained by expressing the mass transfer analog of Eq. 7.53. Neglecting the Pr ratio, the analogous form is

$$\begin{aligned}\overline{Sh}_D &= 0.26 Re_D^{0.6} Sc^{0.37} \\ \overline{Sh}_D &= 0.26 \left(1.96 \times 10^5\right)^{0.6} (0.59)^{0.37} = 320.\end{aligned}$$

Hence

$$\bar{h}_m = 320 \frac{D_{AB}}{D} = \frac{320 \times 0.26 \times 10^{-4} \text{ m}^2/\text{s}}{0.3 \text{ m}} = 0.028 \text{ m/s}.$$

The evaporation rate is then

$$\begin{aligned}\dot{n}_A &= 0.028 \text{ m/s} (\pi \times 0.3 \text{ m} \times 1.75 \text{ m}) [0.0336 - 0.010] \text{ kg/m}^3 \\ \dot{n}_A &= 1.09 \times 10^{-3} \text{ kg/s}.\end{aligned}$$

Hence,

$$q = 485 \text{ W} + 1.09 \times 10^{-3} \text{ kg/s} \times 2.431 \times 10^6 \text{ J/kg}$$

$$q = 485 \text{ W} + 2650 \text{ W} = 3135 \text{ W}.$$

<

**COMMENTS:** The evaporative (latent) heat loss dominates over the sensible heat loss. Its effect is often felt when stepping out of a swimming pool or other body of water.



### PROBLEM 7.137

**KNOWN:** Horizontal tube exposed to transverse stream of dry air.

**FIND:** Equation to determine heat transfer enhancement due to wetting. Evaluate enhancement for prescribed conditions.

**SCHEMATIC:**

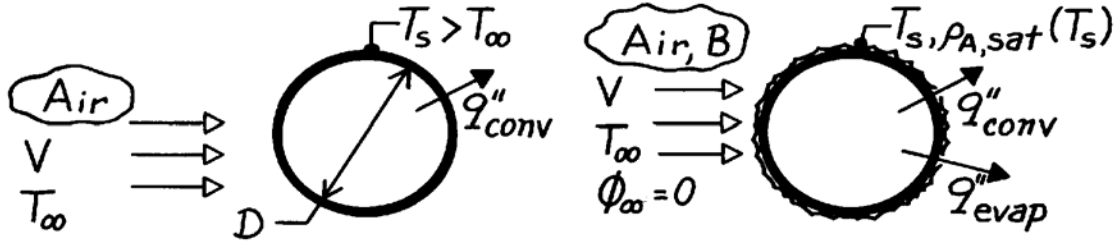

**ASSUMPTIONS:** (1) Steady-state conditions, (2) Heat-mass transfer analogy applicable, (3) Water vapor behaves as perfect gas.

**PROPERTIES:** Table A-4, Air (310K, 1 atm):  $\rho = 1.1281 \text{ kg/m}^3$ ,  $c_p = 1007.4 \text{ J/kg}$ ,  $\nu = 16.90 \times 10^{-6} \text{ m}^2/\text{s}$ ,  $\text{Pr} = 0.706$ ; Table A-8, Air-water vapor mixture (310K):  $D_{AB} \approx 0.26 \times 10^{-4} \text{ m}^2/\text{s}$ ,  $\text{Sc} = \nu_B/D_{AB} = 0.650$ ; Table A-6, Saturated water vapor (320K):  $\rho_{A,\text{sat}} = 1/\nu_g = 0.07153 \text{ kg/m}^3$ ,  $h_{fg} = 2390 \text{ kJ/kg}$ .

**ANALYSIS:** The enhancement due to wetting can be expressed as the ratio of the wet-to-dry cylinder heat fluxes.

$$\frac{q''_w}{q''_d} = \frac{q''_{\text{conv}} + q''_{\text{evap}}}{q''_{\text{conv}}} = 1 + \frac{q''_{\text{evap}}}{q''_{\text{conv}}}$$

where

$$q''_{\text{conv}} = \bar{h}(T_s - T_\infty) \quad q''_{\text{evap}} = \dot{m}''_A h_{fg} = \bar{h}_m (\rho_{A,s} - \rho_{A,\infty}) h_{fg} = \bar{h}_m \rho_{A,\text{sat}} h_{fg}$$

Invoking the heat-mass transfer analogy, using Eq. 6.60, find

$$\frac{\bar{h}}{\bar{h}_m} = (\rho c_p)_B \text{Le}^{1-n} = (\rho c_p)_B (\text{Sc}/\text{Pr})^{2/3}$$

assuming  $n = 1/3$  with  $\rho_{A,\infty} = 0$ , find

$$\frac{q''_w}{q''_d} = 1 + \left[ (\rho c_p)_B (\text{Sc}/\text{Pr})^{2/3} \right]^{-1} \frac{\rho_{A,\text{sat}} h_{fg}}{(T_s - T_\infty)} \quad <$$

Substituting numerical values, the enhancement is

$$\frac{q''_w}{q''_d} = 1 + \left[ \left( 1.1281 \frac{\text{kg}}{\text{m}^3} \times 1007.4 \frac{\text{J}}{\text{kg}} \right) \left( \frac{0.650}{0.706} \right)^{2/3} \right]^{-1} \frac{0.07153 \text{ kg/m}^3 \times 2390 \times 10^3 \text{ J/kg}}{(320 - 300) \text{ K}} = 9.0 \quad <$$

**COMMENTS:** For the prescribed conditions, the effect of wetting is to enhance the heat transfer by nearly an order of magnitude. Will the enhancement increase or decrease with increasing  $T_s$ ?

## PROBLEM 7.138

**KNOWN:** Moisture-soaked paper is cylindrical form maintained at given temperature by imbedded heaters. Dry air at prescribed velocity and temperature in cross flow over cylinder.

**FIND:** (a) Required electrical power and the evaporation rate per unit length,  $q'_{\text{evap}}$  and  $n'_A$ , respectively, and (b) Calculate and plot  $q'$  and  $n'_A$  as a function of dry air velocity  $5 \leq V \leq 20$  m/s and paper temperatures of 65, 70 and 75°C.

**SCHEMATIC:**

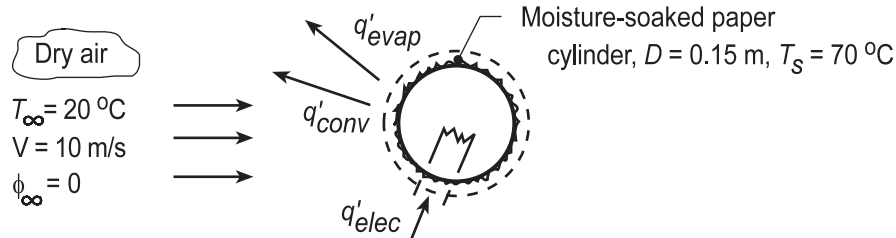

**ASSUMPTIONS:** (1) Steady-state conditions, (2) Heat-mass transfer analogy applicable, (3) Negligible radiation effects.

**PROPERTIES:** Table A.4, Air ( $T_\infty = 20^\circ\text{C} = 293$  K, 1 atm):  $\rho = 1.1941$  kg/m<sup>3</sup>,  $c_p = 1007$  J/kg·K,  $k = 25.7 \times 10^{-3}$  W/m·K,  $\nu = 15.26 \times 10^{-6}$  m<sup>2</sup>/s,  $\text{Pr} = 0.709$ ; ( $T_s = 70^\circ\text{C} = 343$  K):  $\text{Pr}_s = 0.701$ ; Table A.6, Sat. water vapor ( $T_s = 70^\circ\text{C} = 343$  K):  $\rho_{A,s} = 1/\nu_g = 0.196$  kg/m<sup>3</sup>,  $h_{fg} = 2334 \times 10^3$  J/kg; Table A.8, Air-water vapor mixture ( $\bar{T}_f = (T_\infty + T_s)/2 = 318$  K, 1 atm):  $D_{AB} = 0.26 \times 10^{-4}$  m<sup>2</sup>/s  $(318/298)^{3/2} = 0.29 \times 10^{-4}$  m<sup>2</sup>/s.

**ANALYSIS:** (a) From an energy balance on the cylinder on a per unit length basis,

$$q'_{\text{elec}} = q'_{\text{conv}} + q'_{\text{evap}} \quad q'_{\text{elec}} = \pi D \left[ \bar{h} (T_s - T_\infty) + \bar{h}_m (\rho_{A,s} - \rho_{A,\infty}) h_{fg} \right] \quad (1)$$

where  $\rho_{A,\infty} = 0$ , the freestream air is dry, and  $\rho_{A,s} = \rho_{A,\text{sat}}(T_s)$ . To estimate  $\bar{h}$ , find

$$\text{Re}_D = \frac{VD}{\nu} = \frac{10 \text{ m/s} \times 0.15 \text{ m}}{15.26 \times 10^{-6} \text{ m}^2/\text{s}} = 98,296 \quad (2)$$

and using the Zhukauskus correlation, from Table 7.4:  $C = 0.26$ ,  $m = 0.6$ , and  $n = 0.37$ ,

$$\overline{\text{Nu}}_D = \frac{\bar{h}D}{k} = 0.26 \text{Re}^{0.6} \text{Pr}^{0.37} (\text{Pr}/\text{Pr}_s)^{0.25} \quad (3)$$

$$\bar{h} = \frac{0.0257 \text{ W/m} \cdot \text{K}}{0.15 \text{ m}} \times 0.26 (98,296)^{0.6} (0.709)^{0.37} (0.709/0.701)^{0.25} = 38.9 \text{ W/m}^2 \cdot \text{K}.$$

Using the heat-mass analogy with  $n = 1/3$ , find

$$\bar{h}/\bar{h}_m = (\rho c_p)_B (\text{Sc}/\text{Pr})^{2/3} = (\rho c_p)_B (\nu/D_{AB}/\text{Pr})^{2/3} \quad (4)$$

$$\bar{h}_m = 38.9 \text{ W/m}^2 \cdot \text{K} / \left( 1.1941 \text{ kg/m}^3 \times 1007 \text{ J/kg} \cdot \text{K} \right) \left[ \frac{15.26 \times 10^{-6} \text{ m}^2/\text{s} / 0.29 \times 10^{-4} \text{ m}^2/\text{s}}{0.709} \right]^{2/3}$$

$$\bar{h}_m = 0.03946 \text{ m/s}.$$

Hence, the electric power requirement is

$$q'_{\text{elec}} = \pi \times 0.15 \text{ m} \left[ 38.9 \text{ W/m}^2 \cdot \text{K} (70 - 20) \text{ K} + 0.03946 \text{ m/s} (0.196 - 0) \text{ kg/m}^3 \times 2334 \times 10^3 \text{ J/kg} \right]$$

Continued...

### PROBLEM 7.138 (Cont.)

$$q'_{\text{elec}} = (917 + 8507) \text{ W/m} = 9424 \text{ W/m} \quad (5) <$$

(b) The foregoing equations were entered into the IHT Workspace, and using the *Properties Tools*, for air and water vapor required thermophysical properties, the required electrical power,  $q'$ , and evaporation rate,  $n'_A$ , were calculated as a function of dry air velocity for selected water temperatures.

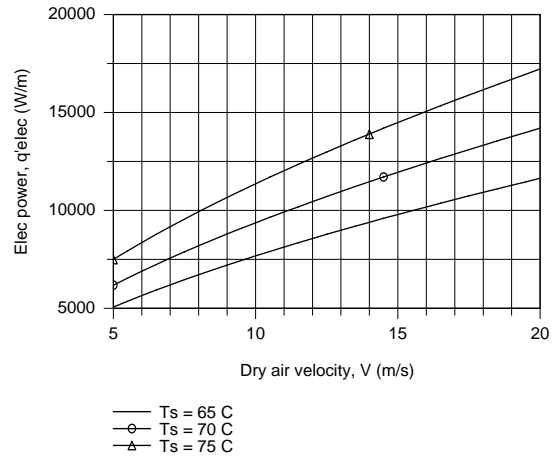
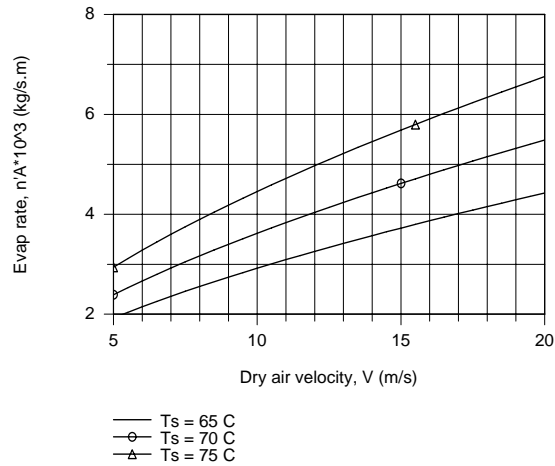

**COMMENTS:** (1) Note at which temperatures the thermophysical properties are evaluated.

(2) From Equation (5), note that the evaporation heat rate far exceeds that due to convection.

(3) From the plots, note that both  $q'_{\text{elec}}$  and  $n'_A$  are nearly proportional to air velocity, and increase with increasing water temperature.

## PROBLEM 7.139

**KNOWN:** Dry- and wet-bulb temperatures associated with a moist airflow through a large diameter duct of prescribed surface temperature.

**FIND:** Temperature and relative humidity of airflow.

**SCHEMATIC:**

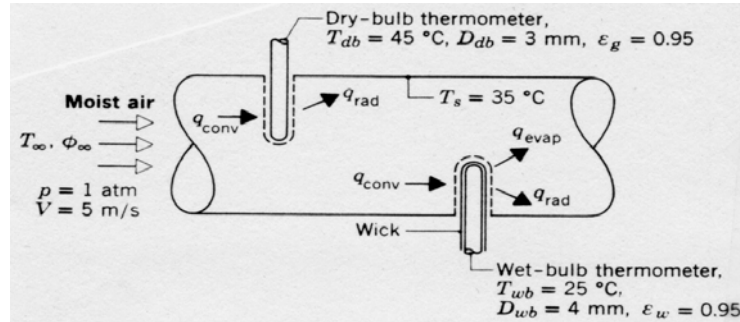

**ASSUMPTIONS:** (1) Steady-state conditions, (2) Conduction along the thermometers is negligible, (3) Duct wall forms a large enclosure about the thermometers.

**PROPERTIES:** Table A-4, Air (318K, 1 atm):  $\nu = 17.7 \times 10^{-6} \text{ m}^2/\text{s}$ ,  $k = 0.0276 \text{ W/m}\cdot\text{K}$ ,  $\text{Pr} = 0.70$ ; Table A-4, Air (298K, 1 atm):  $\nu = 15.7 \times 10^{-6} \text{ m}^2/\text{s}$ ,  $k = 0.0261 \text{ W/m}\cdot\text{K}$ ,  $\text{Pr} = 0.71$ ; Table A-6, Saturated water vapor (298K):  $\nu_g = 44.3 \text{ m}^3/\text{kg}$ ,  $h_{fg} = 2442 \text{ kJ/kg}$ ; Saturated water vapor (318.5K):  $\nu_g = 15.5 \text{ m}^3/\text{kg}$ ; Table A-8, Water vapor-air (298K):  $D_{AB} = 0.26 \times 10^{-4} \text{ m}^2/\text{s}$ ,  $\text{Sc} = 0.60$ .

**ANALYSIS:** *Dry-bulb Thermometer:* Since  $T_{db} > T_s$ , there is net radiation transfer from the surface of the dry-bulb thermometer to the duct wall. Hence to maintain steady-state conditions, the thermometer temperature must be less than that of the air ( $T_{db} < T_\infty$ ) to allow for convection heat transfer from the air. Hence, from application of a surface energy balance to the thermometer,  $q_{\text{conv}} = q_{\text{rad}}$ , or,

$$\bar{h}A_{\text{db}}(T_\infty - T_{\text{db}}) = \varepsilon_g A_{\text{db}} \sigma (T_{\text{db}}^4 - T_s^4).$$

The air temperature is then

$$T_\infty = T_{\text{db}} + \left( \varepsilon_g \sigma / \bar{h} \right) (T_{\text{db}}^4 - T_s^4) \quad (1)$$

where  $\bar{h}$  may be obtained from Eq. 7.53.

*Wet-bulb Temperature:* The relative humidity may be obtained by performing an energy balance on the wet-bulb thermometer. In this case convection heat transfer to the wick is balanced by evaporative and radiative heat losses from the wick,

$$\begin{aligned} q_{\text{conv}} &= q_{\text{evap}} + q_{\text{rad}} & q_{\text{evap}} &= n''_A A_{\text{wb}} h_{fg} = \bar{h}_m \left[ \rho_{A,\text{sat}}(T_{\text{wb}}) - \phi_\infty \rho_{A,\text{sat}}(T_\infty) \right] A_{\text{wb}} h_{fg} \\ \bar{h} A_{\text{wb}} (T_\infty - T_{\text{wb}}) &= \bar{h}_m \left[ \rho_{A,\text{sat}}(T_{\text{wb}}) - \phi_\infty \rho_{A,\text{sat}}(T_\infty) \right] A_{\text{wb}} h_{fg} + \varepsilon_w A_{\text{wb}} \sigma (T_{\text{wb}}^4 - T_s^4) \\ \phi_\infty &= \left\{ \rho_{A,\text{sat}}(T_{\text{wb}}) + \left[ \varepsilon_w \sigma (T_{\text{wb}}^4 - T_s^4) - \bar{h} (T_\infty - T_{\text{wb}}) \right] / h_{fg} \bar{h}_m \right\} / \rho_{A,\text{sat}}(T_\infty) \quad (2) \end{aligned}$$

where  $\bar{h}_m$  may be determined from the mass transfer analog of Eq. 7.53.

Continued ...

### PROBLEM 7.139 (Cont.)

*Convection Calculations:* For the prescribed conditions, the Reynolds number associated with the dry-bulb thermometer is

$$\text{Re}_{D(\text{db})} = VD_{\text{db}} / \nu = 5 \text{ m/s} \times 0.003 \text{ m} / 17.7 \times 10^{-6} \text{ m}^2/\text{s} = 847.$$

Approximating the Prandtl number ratio as unity, from Eq. 7.53 and Table 7.4,

$$\overline{\text{Nu}}_{D(\text{db})} = C \text{Re}_{D(\text{db})}^m \text{Pr}^n = 0.51(847)^{0.5} (0.70)^{0.37} = 13.01$$

$$\bar{h} = 13.01 \frac{k}{D_{\text{db}}} = 13.01 \frac{0.0276 \text{ W/m} \cdot \text{K}}{0.003 \text{ m}} = 120 \text{ W/m}^2 \cdot \text{K}.$$

From Eq. (1) the air temperature is

$$T_{\infty} = 45^{\circ}\text{C} + \frac{0.95 \times 5.67 \times 10^{-8} \text{ W/m}^2 \cdot \text{K}^4}{120 \text{ W/m}^2 \cdot \text{K}} (318^4 - 308^4) \text{ K}^4 = 45^{\circ}\text{C} + 0.55^{\circ}\text{C} = 45.6^{\circ}\text{C}. \quad <$$

The relative humidity may now be obtained from Eq. (2). The Reynolds number associated with the wet-bulb thermometer is

$$\text{Re}_{D(\text{wb})} = VD_{\text{wb}} / \nu = 5 \text{ m/s} \times 0.004 \text{ m} / 15.7 \times 10^{-6} \text{ m}^2/\text{s} = 1274.$$

From Eq. 7.53 and Table 7.4, it follows that

$$\overline{\text{Nu}}_{D(\text{wb})} = 0.26(1274)^{0.6} (0.71)^{0.37} = 16.71$$

$$\bar{h} = 16.71 \frac{k}{D_{\text{wb}}} = 16.71 \frac{0.0261 \text{ W/m} \cdot \text{K}}{0.004 \text{ m}} = 109 \text{ W/m}^2 \cdot \text{K}.$$

Using the mass transfer analog of Eq. 7.53, it also follows that

$$\overline{\text{Sh}}_{D(\text{wb})} = 0.26 \text{Re}_{D(\text{wb})}^{0.6} \text{Sc}^{0.37} = 0.26(1274)^{0.6} (0.6)^{0.37} = 15.7$$

$$\bar{h}_m = 15.7 \frac{D_{\text{AB}}}{D_{\text{wb}}} = \frac{15.7 \times 0.26 \times 10^{-4} \text{ m}^2/\text{s}}{0.004 \text{ m}} = 0.102 \text{ m/s}.$$

Also,  $\rho_{\text{A,sat}}(T_{\text{wb}}) = v_g (298 \text{ K})^{-1} = (44.3 \text{ m}^3/\text{kg})^{-1} = 0.0226 \text{ kg/m}^3$

$$\rho_{\text{A,sat}}(T_{\infty}) = v_g (318.5 \text{ K})^{-1} = (15.5 \text{ m}^3/\text{kg})^{-1} = 0.0645 \text{ kg/m}^3.$$

Hence the relative humidity is, from Eq. (2)

$$\phi_{\infty} = \left( 0.0226 \text{ kg/m}^3 + \frac{[0.95 \times 5.67 \times 10^{-8} \text{ W/m}^2 \cdot \text{K}^4 (298^4 - 308^4) \text{ K}^4 - 109 \text{ W/m}^2 \cdot \text{K} (45.55 - 25) \text{ K}]}{(2.442 \times 10^6 \text{ J/kg})(0.102 \text{ m/s})} \right) / 0.0645 \text{ kg/m}^3$$

$$\phi_{\infty} = 0.21 \quad <$$

**COMMENTS:** (1) The effect of radiation exchange between the duct wall and the thermometers is small. For this reason  $T_{\infty} = T_{\text{db}}$ . (2) The evaporative heat loss is significant due to the small value of  $\phi_{\infty}$ , causing  $T_{\text{wb}}$  to be significantly less than  $T_{\infty}$ .

### PROBLEM 7.140

**KNOWN:** Velocity, diameter and temperature of a spherical droplet. Conditions of surroundings.

**FIND:** (a) Expressions for droplet evaporation and cooling rates, (b) Evaporation and cooling rates for prescribed conditions.

**SCHEMATIC:**

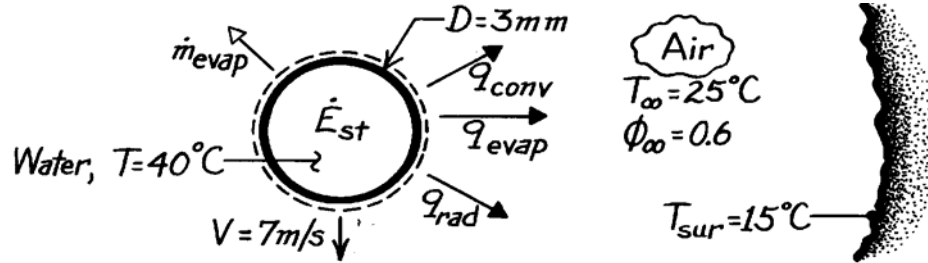

**ASSUMPTIONS:** (1) Negligible temperature gradients in the drop, (2) Heat and mass transfer analogy is applicable, (3) Perfect gas behavior for vapor.

**PROPERTIES:** Table A-4, Air ( $T_\infty = 298\text{K}$ , 1 atm):  $\nu = 15.71 \times 10^{-6} \text{ m}^2/\text{s}$ ,  $k = 0.0261 \text{ W/m}\cdot\text{K}$ ,  $\text{Pr} = 0.71$ ; Table A-6, Water ( $T = 40^\circ\text{C}$ ):  $\rho_{A,\text{sat}} = 0.050 \text{ kg/m}^3$ ,  $h_{fg} = 2407 \text{ kJ/kg}$ ,  $\rho_\ell = 992 \text{ kg/m}^3$ ,  $c_{p,\ell} = 4179 \text{ J/kg}\cdot\text{K}$ ; ( $T_\infty = 25^\circ\text{C}$ ):  $\rho_{A,\text{sat}} = 0.023 \text{ kg/m}^3$ ; Table A-8, Water vapor-air (298K):  $D_{AB} = 0.26 \times 10^{-4} \text{ m}^2/\text{s}$ .

**ANALYSIS:** (a) The evaporation rate is given by

$$\dot{m}_{\text{evap}} = \bar{h}_m A_s (\rho_{A,s} - \rho_{A,\infty}) = \bar{h}_m \pi D^2 [\rho_{A,\text{sat}}(T) - \phi_\infty \rho_{A,\text{sat}}(T_\infty)]. \quad <$$

The cooling rate is obtained from an energy balance performed for a control surface about the droplet,

$$\dot{E}_{\text{st}} = -\dot{q}_{\text{out}} = -(\dot{q}_{\text{conv}} + \dot{q}_{\text{rad}} + \dot{q}_{\text{evap}})$$

$$\text{or} \quad \frac{d}{dt} \left( \rho_\ell \frac{\pi D^3}{6} c_{p,\ell} T \right) = -A_s \left[ \bar{h} (T_s - T_\infty) + \varepsilon \sigma (T_s^4 - T_{\text{sur}}^4) + \dot{m}_{\text{evap}}'' h_{fg} \right].$$

With  $A_s = \pi D^2$ , it follows that

$$\frac{dT}{dt} = -\frac{6}{\rho_\ell c_{p,\ell} D} \left[ \bar{h} (T_s - T_\infty) + \varepsilon \sigma (T_s^4 - T_{\text{sur}}^4) + \dot{m}_{\text{evap}}'' h_{fg} \right]. \quad <$$

(b) To obtain  $\bar{h}_m$ , the mass transfer analog of the Ranz-Marshall correlation gives

$$\bar{\text{Sh}}_D = 2 + 0.6 \text{Re}_D^{1/2} \text{Sc}^{1/3}$$

where

$$\text{Re}_D = \frac{VD}{\nu} = \frac{7 \text{ m/s} \times 0.003 \text{ m}}{15.71 \times 10^{-6} \text{ m}^2/\text{s}} = 1337, \quad \text{Sc} = \frac{\nu}{D_{AB}} = \frac{15.71 \times 10^{-6}}{26 \times 10^{-6}} = 0.60.$$

Continued ...

**PROBLEM 7.140 (Cont.)**

Hence

$$\overline{Sh}_D = 2 + 0.6(1337)^{1/2} (0.6)^{1/3} = 20.5$$

$$\bar{h}_m = \overline{Sh}_D \frac{D_{AB}}{D} = 20.5 \frac{0.26 \times 10^{-4} \text{ m}^2/\text{s}}{0.003 \text{ m}} = 0.18 \text{ m/s}$$

$$\dot{m}_{\text{evap}} = 0.18 \text{ m/s} \pi (0.003 \text{ m})^2 [0.05 - 0.6 \times 0.023] \text{ kg/m}^3 = 1.82 \times 10^{-7} \text{ kg/s.} \quad <$$

The evaporative heat flux is then

$$q''_{\text{evap}} = \frac{q_{\text{evap}}}{A_s} = \frac{\dot{m}_{\text{evap}} h_{fg}}{\pi D^2} = \frac{1.82 \times 10^{-7} \text{ kg/s} (2.407 \times 10^6 \text{ J/kg})}{\pi (0.003 \text{ m})^2}$$

$$q''_{\text{evap}} = 15,494 \text{ W/m}^2.$$

Using the heat transfer correlation, the Nusselt number is

$$\overline{Nu}_D = 2 + 0.6 Re_D^{1/2} Pr^{1/3} = 2 + 0.6(1337)^{1/2} (0.71)^{1/3} = 21.58.$$

Hence 
$$\bar{h} = \overline{Nu}_D \frac{k}{D} = 21.58 \frac{0.0261 \text{ W/m} \cdot \text{K}}{0.003 \text{ m}} = 188 \text{ W/m}^2 \cdot \text{K}$$

and the sensible heat flux is

$$q''_{\text{conv}} = \bar{h} (T - T_\infty) = 188 \text{ W/m}^2 \cdot \text{K} (40 - 25)^\circ \text{C}$$

$$q''_{\text{conv}} = 2815 \text{ W/m}^2.$$

The net radiative flux is

$$q''_{\text{rad}} = \varepsilon \sigma (T^4 - T_{\text{sur}}^4) = 0.95 \times 5.67 \times 10^{-8} \text{ W/m}^2 \cdot \text{K}^4 [313^4 - 288^4] \text{ K}^4$$

$$q''_{\text{rad}} = 146 \text{ W/m}^2 \cdot \text{K}.$$

Hence 
$$\frac{dT}{dt} = - \frac{6}{992 \text{ kg/m}^3 \times 4179 \text{ J/kg} \cdot \text{K} (0.003 \text{ m})} (2815 + 146 + 15,494) \text{ W/m}^2$$

$$\frac{dT}{dt} = -8.9 \text{ K/s.} \quad <$$

**COMMENTS:** (1) Evaporative cooling provides the dominant heat loss from the drop. (2) To test the validity of assuming negligible temperature gradients in the drop, calculate

$$Bi \approx \frac{h_{\text{eff}} (r_o/3)}{k_\ell}, \quad \text{where } h_{\text{eff}} \equiv \frac{q''_{\text{tot}}}{T - T_\infty} = \frac{18,455}{25} = 738 \text{ W/m}^2 \cdot \text{K}.$$

From Table A-6,  $k_\ell = 0.631 \text{ W/m} \cdot \text{K}$ , hence

$$Bi \approx \frac{738 \text{ W/m}^2 \cdot \text{K} (0.0005 \text{ m})}{0.631 \text{ W/m} \cdot \text{K}} = 0.58.$$

Hence, although suspect, the assumption is not totally unreasonable.

## PROBLEM 7.141

**KNOWN:** Cranberries with an average diameter of 15 mm rolling over a fine screen. Thickness of the water film is 0.2 mm.

**FIND:** Time required to dry the berries exposed to heated air with a velocity of 2 m/s and temperature of 30°C.

**SCHEMATIC:**

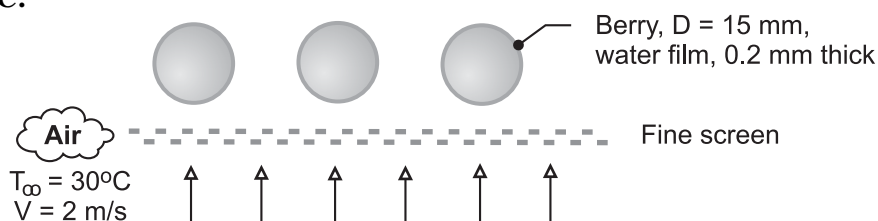

**ASSUMPTIONS:** (1) Steady-state conditions, (2) Air stream is dry, (3) Water film on the berries is also at 30°C, (4) Convection process is uniform over the exposed surface, and (5) Heat-mass analogy is applicable.

**PROPERTIES:** Table A-6, Water ( $T_f = 30^\circ\text{C} = 303 \text{ K}$ ):  $\rho_{A,f} = 995.8 \text{ kg/m}^3$ ,  $\rho_{A,g} = 0.02985 \text{ kg/m}^3$ ; Table A-8, Water-air ( $T_f = 303 \text{ K}$ , 1 atm):  $D_{AB} = 0.26 \times 10^{-4} \text{ m}^2/\text{s} (303/298)^{1.5} = 2.67 \times 10^{-5} \text{ m}^2/\text{s}$ ; Table A-4, Air ( $T_f = 303 \text{ K}$ , 1 atm):  $\mu = \mu_s = 1.86 \times 10^{-5} \text{ N}\cdot\text{s/m}^2$ ,  $\nu = 1.619 \times 10^{-5} \text{ m}^2/\text{s}$ ,  $\alpha = 2.294 \times 10^{-5} \text{ m}^2/\text{s}$ ,  $k = 0.02652 \text{ W/m}\cdot\text{K}$ ,  $\text{Pr} = 0.707$ .

**ANALYSIS:** The evaporation rate of water from the berry surface is given by the rate equation,

$$n = \bar{h}_m A_s (\rho_{A,s} - \rho_{A,\infty}) \quad (1)$$

where  $A_s = \pi D^2$  and  $\bar{h}_m$  is determined using the heat-mass analogy, Eq. 6.60,

$$\frac{\bar{h}}{\bar{h}_m} = \frac{k}{D_{AB}} \text{Le}^{-n} \quad (2)$$

where  $\text{Le} = \alpha/D_{AB}$  and typically  $n = 1/3$ . The heat transfer coefficient  $\bar{h}$  is estimated with the Whitaker correlation, Eq. 7.56,

$$\overline{\text{Nu}}_D = \frac{\bar{h}D}{k} = 2 + \left[ 0.4 \text{Re}_D^{1/2} + 0.06 \text{Re}_D^{2/3} \right] \text{Pr}^{0.4} (\mu/\mu_s)^{1/4} \quad (3)$$

Substituting numerical values, find

$$\text{Re}_D = \frac{VD}{\nu} = \frac{2 \text{ m/s} \times 0.015 \text{ m}}{1.619 \times 10^{-5} \text{ m}^2/\text{s}} = 1853$$

$$\text{Nu}_D = 2 + \left[ 0.4(1853)^{1/2} + 0.06(1853)^{2/3} \right] \times (0.707)^{0.4} \times 1 = 24.9$$

$$\bar{h} = 24.9 \times 0.02652 \text{ W/m}\cdot\text{K} / 0.015 \text{ m} = 44.0 \text{ W/m}^2\cdot\text{K}$$

and using the heat-mass analogy,

$$\bar{h}_m = 44.0 \text{ W/m}^2\cdot\text{K} \times \left( 2.67 \times 10^{-5} \text{ m}^2/\text{s} / 0.02652 \text{ W/m}\cdot\text{K} \right) \times (0.861)^{1/3}$$

$$\bar{h}_m = 0.0420 \text{ m/s}$$

Continued ...



### PROBLEM 7.141 (Cont.)

where

$$\text{Le} = \alpha / D_{AB} = 2.294 \times 10^{-5} \text{ m}^2 / \text{s} / 2.667 \times 10^{-5} \text{ m}^2 / \text{s} = 0.861$$

Using Eq. (1), the evaporation rate is

$$\dot{n} = 0.0420 \text{ m/s} \times \left( \pi (0.015 \text{ m})^2 \right) (0.02985 - 0) \text{ kg/m}^3 = 8.87 \times 10^{-7} \text{ kg/s}$$

The time,  $t_o$ , required to evaporate the water film of thickness  $\delta = 0.2 \text{ mm}$  is

$$\dot{n} t_o = M_{\text{film}} = \rho_{A,\ell} \left( \pi D^2 \right) \delta$$

$$t_o = 995.8 \text{ kg/m}^3 \left( \pi \times (0.015 \text{ m})^2 \right) \times 0.0002 \text{ m} / 8.87 \times 10^{-7} \text{ kg/s}$$

$$t_o = 159 \text{ s}$$

<

### PROBLEM 7.142

**KNOWN:** Spherical droplet at prescribed temperature and velocity falling in still, hotter dry air.

**FIND:** Instantaneous rate of evaporation.

**SCHEMATIC:**

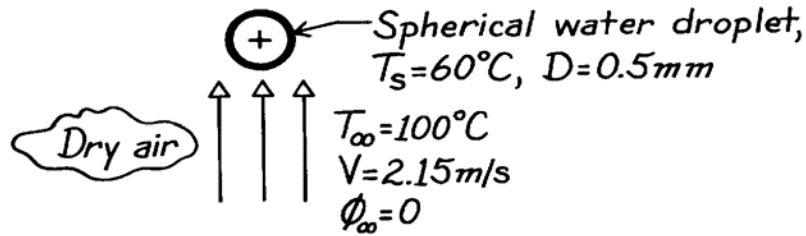

**ASSUMPTIONS:** (1) Steady-state conditions, (2) Heat-mass transfer analogy applicable.

**PROPERTIES:** Table A-4, Air ( $T_\infty = 100^\circ\text{C} = 373\text{K}$ , 1 atm):  $\rho = 0.9380\text{ kg/m}^3$ ,  $c_p = 1011\text{ J/kg}\cdot\text{K}$ ,  $k = 0.0317\text{ W/m}\cdot\text{K}$ ,  $\nu = 23.45 \times 10^{-6}\text{ m}^2/\text{s}$ ,  $\text{Pr} = 0.695$ ; Table A-6, Sat. water ( $T_s = 60^\circ\text{C} = 333\text{K}$ ):  $\rho_\ell = 1/\nu_\ell = 983\text{ kg/m}^3$ ,  $\rho_{A,s} = 1/\nu_f = 0.129\text{ kg/m}^3$ ; Table A-8, Air-water vapor mixture ( $T_\infty = 373\text{K}$ , 1 atm):  $D_{AB} = 0.267 \times 10^{-4}\text{ m}^2/\text{s} (373/298)^{3/2} = 0.36 \times 10^{-4}\text{ m}^2/\text{s}$ .

**ANALYSIS:** The instantaneous evaporation rate is

$$\dot{n}_A = \bar{h}_m A_s (\rho_{A,s} - \rho_{A,\infty})$$

where  $A_s = \pi D^2$ ,  $\rho_{A,\infty} = 0$  and  $\rho_{A,s} = \rho_{A,\text{sat}}(T_s)$ . To estimate  $\bar{h}_m$  use the Whitaker correlation, written in terms of mass transfer parameters and with  $\mu/\mu_s \approx 1$ ,

$$\overline{\text{Sh}}_D = \frac{\bar{h}_m D}{D_{AB}} = 2 + \left( 0.4 \text{Re}_D^{1/2} + 0.06 \text{Re}_D^{2/3} \right) \text{Sc}^{0.4}$$

$$\bar{h}_m = \frac{0.36 \times 10^{-4}\text{ m}^2/\text{s}}{0.0005\text{ m}} \left[ 2 + \left( 0.4(45.8)^{1/2} + 0.06(45.8)^{2/3} \right) \times 0.651^{0.4} \right] = 0.355\text{ m/s}$$

where 
$$\text{Re}_D = \frac{VD}{\nu} = \frac{2.15\text{ m/s} \times 0.0005\text{ m}}{23.45 \times 10^{-6}\text{ m}^2/\text{s}} = 45.8$$

$$\text{Sc} = \nu/D_{AB} = 23.45 \times 10^{-6}\text{ m}^2/\text{s} / 0.36 \times 10^{-4}\text{ m}^2/\text{s} = 0.651.$$

Hence, the evaporation rate is

$$\dot{n}_A = 0.355\text{ m/s} \times \pi (0.0005\text{ m})^2 (0.129 - 0)\text{ kg/m}^3 = 3.60 \times 10^{-8}\text{ kg/s.} \quad <$$

**COMMENTS:** If this evaporation rate were to remain constant with time, the droplet of mass  $M$  would be completely evaporated in

$$\Delta t = M/\dot{n}_A = \frac{\rho_\ell (\pi D^3 / 6)}{\dot{n}_A} = \frac{983\text{ kg/m}^3 (\pi (0.0005\text{ m})^3 / 6)}{3.60 \times 10^{-8}\text{ kg/s}} = 1.8\text{ s.}$$

To determine whether the droplet temperature will increase or decrease with time, it is necessary to compare convective heat and evaporation rates. Hence it is not clear whether the time to completely evaporate will be less or greater than 1.8 s.

### PROBLEM 7.143

**KNOWN:** Diameter, velocity and surface vapor concentration of alcohol droplet falling in quiescent air. Latent heat of vaporization and diffusion coefficient. Air temperature.

**FIND:** Droplet surface temperature

**SCHEMATIC:**

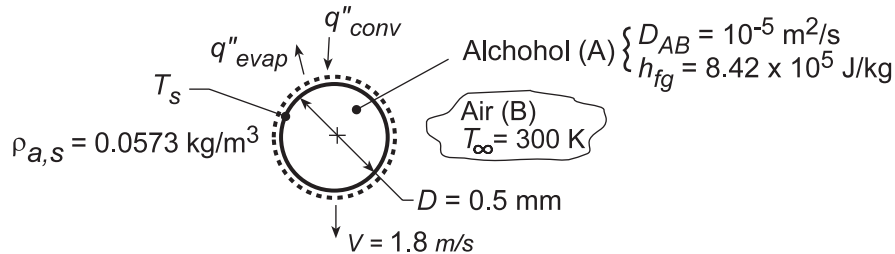

**ASSUMPTIONS:** (1) Steady-state conditions, (2) Applicability of heat and mass transfer analogy, (3) Negligible radiation, (4) Negligible vapor concentration in air ( $\rho_{A,\infty} = 0$ ).

**PROPERTIES:** Table A.4, air ( $T_\infty = 300$  K):  $\nu = 15.89 \times 10^{-6} \text{ m}^2/\text{s}$ ,  $k = 0.0263 \text{ W/m}\cdot\text{K}$ ,  $\text{Pr} = 0.707$ .

**ANALYSIS:** Application of a surface energy balance yields

$$q''_{\text{evap}} = q''_{\text{conv}}$$

$$\bar{h}_m (\rho_{A,s} - \rho_{A,\infty}) h_{fg} = \bar{h} (T_\infty - T_s)$$

$$T_s = T_\infty - \frac{\bar{h}_m}{\bar{h}} \rho_{A,s} h_{fg}$$

With  $\text{Re}_D = VD/\nu = 1.8 \text{ m/s} \times 5 \times 10^{-4} \text{ m} / 15.89 \times 10^{-6} \text{ m}^2/\text{s} = 56.6$  and  $\text{Sc} = \nu/D_{AB} = 1.59$ , the Ranz-Marshall correlation yields

$$\overline{\text{Nu}}_D = 2 + 0.6 \text{Re}_D^{1/2} \text{Pr}^{1/3} = 2 + 0.6(56.6)^{1/2} (0.707)^{1/3} = 6.02$$

$$\overline{\text{Sh}}_D = 2 + 0.6 \text{Re}_D^{1/2} \text{Sc}^{1/3} = 2 + 0.6(56.6)^{1/2} (1.59)^{1/3} = 7.27$$

With  $\bar{h}_m/\bar{h} = \overline{\text{Sh}}_D (D_{AB}/D) / \overline{\text{Nu}}_D (k/D)$ ,

$$\frac{\bar{h}_m}{\bar{h}} = \frac{\overline{\text{Sh}}_D (D_{AB})}{\overline{\text{Nu}}_D (k)} = \frac{7.27 \times 10^{-5} \text{ m}^2/\text{s}}{6.02 \times 0.0263 \text{ W/m}\cdot\text{K}} = 4.59 \times 10^{-4} \text{ m}^3 \cdot \text{K}/\text{J}$$

Hence,

$$T_s = 300 \text{ K} - 4.59 \times 10^{-4} \text{ m}^3 \cdot \text{K}/\text{J} \left( 0.0573 \text{ kg}/\text{m}^3 \right) \left( 8.42 \times 10^5 \text{ J}/\text{kg} \right) = 277.9 \text{ K} \quad <$$

**COMMENTS:** The large vapor density,  $\rho_{A,s}$ , renders the *evaporative cooling* effect significant.

## PROBLEM 7.144

**KNOWN:** Diameter and density of liver cells, diameter of droplets.

**FIND:** (a) Terminal velocity of the droplets when each droplet contains one liver cell, (b) Time of flight of a droplet containing one liver cell if the distance between injector and scaffold is  $L = 4$  mm, (c) Initial evaporation rate from the droplet, (d) Comparison of the mass variation due to evaporation to variation due to liver cell populations ranging from one to five per droplet.

**SCHEMATIC:**

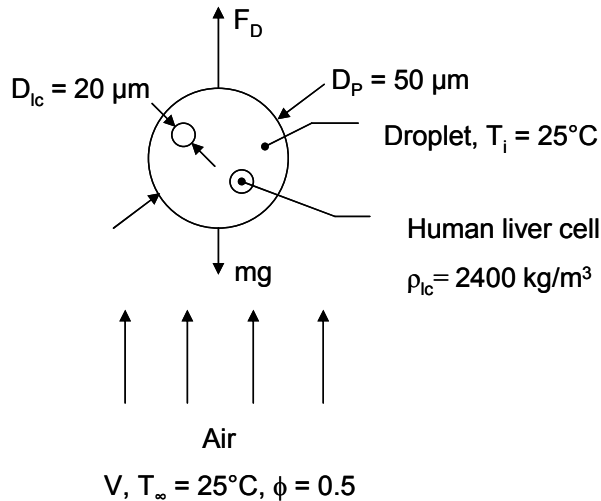

**ASSUMPTIONS:** (1) Constant properties, (2) Negligible evaporative cooling, (3) Stokes' law is valid,  $C_D = 24/Re_D$ , (4) Neglect mass of displaced air in force balance, (5) Evaporation rate is unaffected by change in droplet diameter, (6) Negligible microscale mass transfer effects.

**PROPERTIES:** Table A.4, air: ( $T = 25$  °C = 298 K):  $\rho = 1.171$  kg/m<sup>3</sup>,  $\nu = 15.71 \times 10^{-6}$  m<sup>2</sup>/s, Table A.6, liquid water: ( $T = 25$  °C = 298 K):  $\rho = 997.4$  kg/m<sup>3</sup>, Table A.6, water vapor: ( $T = 25$  °C = 298 K):  $v_g = 44.25$  m<sup>3</sup>/kg. Table A.8, water vapor in air: ( $T = 25$  °C = 298 K):  $D_{AB} = 0.26 \times 10^{-4}$  m<sup>2</sup>/s.

**ANALYSIS:**

(a) At terminal velocity, the force balance is

$$Mg = C_D A_f (\rho V^2 / 2) \quad (1)$$

The mass of the particle,  $M$ , is

$$M = \nabla_{lc} \rho_{lc} + (\nabla_p - \nabla_{lc}) \rho_p \quad (2)$$

The volume of the droplet is  $\nabla_p = \frac{4}{3} \pi \times (25 \times 10^{-6} \text{ m})^3 = 6.54 \times 10^{-14} \text{ m}^3$  while the volume of a

liver cell is  $\nabla_{lc} = \frac{4}{3} \pi \times (10 \times 10^{-6} \text{ m})^3 = 4.12 \times 10^{-15} \text{ m}^3$  and the frontal area is

$$A_f = \pi \times (25 \times 10^{-6} \text{ m})^2 = 1.963 \times 10^{-9} \text{ m}^2.$$

The mass is therefore

$$M = 4.12 \times 10^{-15} \text{ m}^3 \times 2400 \text{ kg/m}^3 + (6.54 \times 10^{-14} \text{ m}^3 - 4.12 \times 10^{-15} \text{ m}^3) \times 997.4 \text{ kg/m}^3$$

$$M = 7.10 \times 10^{-11} \text{ kg} \quad (3)$$

Note that  $C_D = 24/Re_D = 24 \nu / VD_p$  (4)

Continued....

### PROBLEM 7.144 (Cont.)

Combining Equations 1, 2 and 3 yields

$$V = \frac{M_g D_p}{12\nu A_f \rho} = \frac{7.10 \times 10^{-11} \text{ kg} \times 9.8 \text{ m/s}^2 \times 50 \times 10^{-6} \text{ m}}{12 \times 15.71 \times 10^{-6} \text{ m}^2/\text{s} \times 1.963 \times 10^{-9} \text{ m}^2 \times 1.171 \text{ kg/m}^3}$$

$$V = 0.080 \text{ m/s} \quad <$$

The volume fraction of liver cells in the slurry is

$$f = \nabla_{lc} / \nabla_p = 4.12 \times 10^{-15} \text{ m}^3 / 6.54 \times 10^{-14} \text{ m}^3 = 0.063 \quad <$$

(b) The time of flight is

$$t = L/V = 4 \times 10^{-3} \text{ m} / 0.080 \text{ m/s} = 50 \times 10^{-3} \text{ s} = 50 \text{ ms} \quad <$$

(c) With  $Sc = \nu/D_{AB} = 1.571 \times 10^{-5} \text{ m}^2/\text{s} / 0.26 \times 10^{-4} \text{ m}^2/\text{s} = 0.604$ , the heat and mass transfer analogy may be applied to Whitaker's correlation to yield

$$\bar{h}_D = \frac{D_{AB}}{D_p} \left\{ 2 + \left[ 0.4\sqrt{Re_D} + 0.06(Re_D)^{2/3} \right] Pr^{0.4} \right\}$$

The Reynolds number is  $Re_D = VD_p/\nu = 0.08 \text{ m/s} \times 50 \times 10^{-6} \text{ m} / 15.71 \times 10^{-6} \text{ m}^2/\text{s} = 0.255$ .

Hence,

$$\bar{h}_D = \frac{0.26 \times 10^{-4} \text{ m}^2/\text{s}}{50 \times 10^{-6} \text{ m}} \left\{ 2 + \left[ 0.4\sqrt{0.255} + 0.06(0.255)^{2/3} \right] 0.604^{0.4} \right\}$$

$$\bar{h}_D = 1.14 \text{ m/s}$$

The initial evaporation rate is

$$n_A = \bar{h}_D A (\rho_{A,sat} - \phi \rho_{A,sat})$$

$$n_A = 1.14 \text{ m/s} \times \pi \times (50 \times 10^{-6} \text{ m})^2 \times \left[ \frac{1}{44.25} - \frac{0.5}{44.25} \right] \frac{\text{kg}}{\text{m}^3} = 1.01 \times 10^{-10} \text{ kg/s} \quad <$$

(d) The sensitivity may be estimated by comparing the change in mass due to evaporation to the difference in mass due to liver cell loading.

Evaporation

$$\Delta M = n_A t = 1.01 \times 10^{-10} \text{ kg/s} \times 50 \times 10^{-3} \text{ s} = 5.05 \times 10^{-12} \text{ kg} \quad <$$

Loading

The droplet mass with 3 liver cells is

$$M_3 = 3 \times 4.12 \times 10^{-15} \text{ m}^3 \times 2400 \text{ kg/m}^3 + (6.54 \times 10^{-14} \text{ m}^3 - 3 \times 4.12 \times 10^{-15} \text{ m}^3) \times 997.4 \text{ kg/m}^3$$

$$M_3 = 8.26 \times 10^{-11} \text{ kg}$$

The change in mass relative to one liver cell in the droplet is

$$\Delta M = M_3 - M_1 = 8.26 \times 10^{-11} \text{ kg} - 7.10 \times 10^{-11} \text{ kg} = 1.16 \times 10^{-11} \text{ kg} \quad <$$

The change in mass is more sensitive to variations in the number of liver cells than to evaporation.

**COMMENTS:** (1) Inspection of Figure 7.9 shows that Stokes' law is valid at  $Re_D = 0.255$ .

## PROBLEM 7.145

**KNOWN:** Dimension and approximate shape of E. coli bacterium. Binary diffusivity, nutrient value, propulsion efficiency and concentration difference from free stream water-based solution to bacterium shell.

**FIND:** Estimate the maximum E. coli speed in body diameters per second.

**SCHEMATIC:**

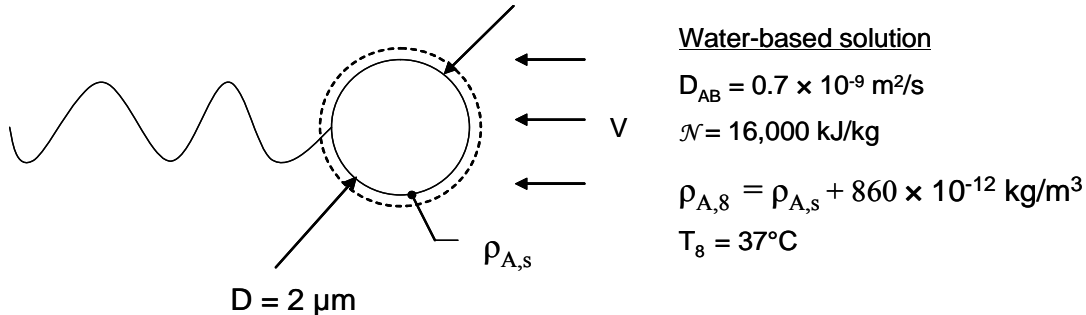

**ASSUMPTIONS:** (1) Negligible capability of bacterium to store energy, (2) Constant properties, (3) Steady-state, (4) Stokes' law is valid, that is  $C_D = 24/Re_D$ , (5) Negligible microscale mass transfer effects.

**PROPERTIES:** Table A.6, water ( $T = 37\text{ }^\circ\text{C} = 310\text{ K}$ ):  $\rho = 993\text{ kg/m}^3$ ,  $\nu = 6.999 \times 10^{-7}\text{ m}^2/\text{s}$ ,  $Pr = 0.701$ .

**ANALYSIS:** For the spherical bacterium shell

$$Re_D = VD/\nu = (V \times 2 \times 10^{-6}\text{ m}) / (6.999 \times 10^{-7}\text{ m}^2/\text{s}) = 2.858\text{ (s/m)} \times V \quad (1)$$

The power required to propel the bacterium is

$$P = F_D V = \frac{C_D A_f \rho V^2}{2} V = \frac{C_D \pi D^2 \rho V^3}{8} \quad (2)$$

assuming  $C_D = \frac{24}{Re_D} = \frac{24}{2.858\text{ (s/m)} V}$

We may combine Equations 1 and 2 to yield

$$\begin{aligned} P &= \frac{24}{2.858} \frac{\pi D^2 \rho V^2}{8} = \frac{3}{2.858\text{ s/m}} \times \pi \times (2 \times 10^{-6}\text{ m})^2 \times 993\text{ kg/m}^3 \times V^2 \\ &= 13.1 \times 10^{-9}\text{ W s}^2/\text{m}^2 (V)^2 \end{aligned}$$

For  $\eta = 0.5$ , the energy to be delivered from the water-based solution to the bacterium is

$$E = P/\eta = 26.2 \times 10^{-9}\text{ W s}^2/\text{m}^2 (V)^2 \quad (3)$$

The energy supplied to the bacterium is

$$E = \bar{h}_m A \mathcal{N} \Delta C = \bar{h}_m \rho D^2 \mathcal{N} \Delta C / 4$$

$$E = \bar{h}_m \pi (2 \times 10^{-6}\text{ m})^2 \times 16,000\text{ kJ/kg} \times 860 \times 10^{-12}\text{ kg/m}^3 / 4$$

Continued...

### PROBLEM 7.145 (Cont.)

$$E = 43.23 \times 10^{-18} \text{ Ws/m} \times \bar{h}_m \quad (4)$$

Applying the heat and mass transfer analogy to the Whitaker correlation yields

$$\overline{\text{Sh}}_D = \frac{\bar{h}_m D}{D_{AB}} = 2 + (0.4\sqrt{\text{Re}_D} + 0.06 \text{Re}_D^{2/3}) \text{Sc}^{0.4} \left(\frac{1}{1}\right)$$

$$\text{where } \text{Sc} = \nu/D_{AB} = 6.999 \times 10^{-7} \text{ m}^2/\text{s} / (0.7 \times 10^{-9} \text{ m}^2/\text{s}) = 1000$$

Therefore

$$\bar{h}_m = \frac{0.7 \times 10^{-9} \text{ m}^2/\text{s}}{2 \times 10^{-6} \text{ m}} \left[ 2 + \left( 0.4\sqrt{2.858 \text{ s/m} \times V} + 0.06(2.858 \text{ s/m} \times V)^{2/3} \right) \times 1000^{0.4} \right] \quad (5)$$

Combining Equations (3) through (5) and solving for V yields

$$V = 70 \times 10^{-6} \text{ m/s} = 70 \text{ } \mu\text{m/s}$$

$$\text{or } V = 70 \text{ } \mu\text{m/s} \times 1 \text{ body diameter} / 2 \text{ } \mu\text{m} = 35 \text{ body diameters/s} \quad \leftarrow$$

**COMMENTS:** (1) The maximum Reynolds number is  $\text{Re}_D = VD/\nu = 70 \times 10^{-6} \text{ m/s} \times 2 \times 10^{-6} \text{ m} / 6.999 \times 10^{-7} \text{ m}^2/\text{s} = 200 \times 10^{-6}$ . The Whitaker correlation is extrapolated outside of its range of application and provides a Sherwood number of 2.093 and a mass transfer coefficient of  $732 \times 10^{-6} \text{ m/s}$ . Using a Sherwood number of two, one would calculate a mass transfer coefficient of  $700 \times 10^{-6} \text{ m/s}$ . Using the limiting value of the Sherwood number would change the answer by less than 5%. (2) The small Reynolds number validates the application of Stokes' law. (3) It is hypothesized that the direction of rotation of the flagellum (clockwise or counterclockwise) is driven by the spatial concentration gradient in the solution. The direction of rotation changes with the solutions' nutrient concentration gradient in a manner that consistently "steers" the bacterium into more fertile feeding grounds. (4) The bacterium splits into multiple bacteria when it is stationary. Presumably, the energy needed to split the bacterium is available since no power is needed to propel the E. coli during splitting.

## PROBLEM 7.146

**KNOWN:** Humidity and temperature of air entering heater; temperature of air leaving heater. Diameter, temperature and relative velocity of injected droplets.

**FIND:** Droplet evaporation rate.

**SCHEMATIC:**

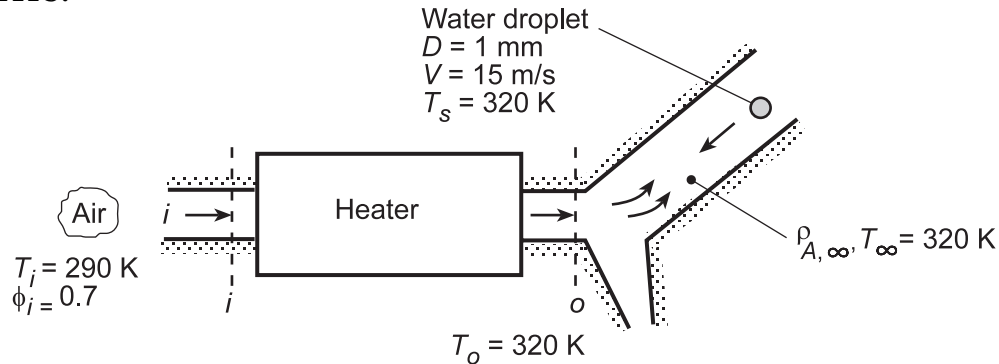

**ASSUMPTIONS:** (1) Negligible change in droplet diameter due to evaporation, (2) Negligible cooling of droplet due to evaporation, (3) Applicability of heat/mass transfer analogy, (4) Ideal gas behavior for vapor.

**PROPERTIES:** Table A.4, air ( $T_\infty = T_o = 320 \text{ K}$ ):  $\nu = 17.90 \times 10^{-6} \text{ m}^2/\text{s}$ ,  $k = 0.0278 \text{ W/m}\cdot\text{K}$ ,  $\text{Pr} = 0.705$ . Table A.6, saturated water ( $T_i = 290 \text{ K}$ ):  $p_{\text{sat}} = 0.01917 \text{ bars}$ ; ( $T_o = 320 \text{ K}$ ):  $p_{\text{sat}} = 0.1053 \text{ bars}$ ,  $\nu_g = 13.98 \text{ m}^3/\text{kg}$ . Table A.8,  $\text{H}_2\text{O}/\text{air}$  ( $T = 320 \text{ K}$ ):  $D_{\text{AB}} = 0.26 \times 10^{-4} \text{ m}^2/\text{s}$  ( $320/298$ ) $^{3/2} = 0.289 \times 10^{-4} \text{ m}^2/\text{s}$ .

**ANALYSIS:** Due to an increase in temperature, the air leaves the heater with a smaller relative humidity. With  $\phi_i = 0.7$  and  $p_{\text{sat},i} = 0.01917 \text{ bars}$ , the vapor pressure at the heater inlet is  $p_i = \phi_i p_{\text{sat},i} = 0.7(0.01917 \text{ bars}) = 0.0134 \text{ bars}$ . Since the vapor pressure doesn't change with passage through the heater,

$$\phi_o = \frac{p_i}{p_{\text{sat},o}} = \frac{0.0134 \text{ bars}}{0.1053 \text{ bars}} = 0.127$$

The vapor density associated with air flow around the droplets is therefore

$$\rho_{\text{A},\infty} = \phi_o \rho_{\text{A},\text{sat}}(T_o) = \phi_o \nu_g(T_o)^{-1} = 0.127 \times 0.0715 \text{ kg/m}^3 = 0.0091 \text{ kg/m}^3$$

The droplet evaporation rate is

$$\dot{m}_{\text{evap}} = \bar{h}_m A_s [\rho_{\text{A},\text{sat}}(T_s) - \rho_{\text{A},\infty}]$$

where  $\bar{h}_m$  may be obtained from the mass transfer analog to the Whitaker correlation. With  $\text{Re}_D = VD/\nu = 15 \text{ m/s} \times 0.001 \text{ m}/17.9 \times 10^{-6} \text{ m}^2/\text{s} = 838$ ,  $\text{Sc} = \nu/D_{\text{AB}} = 17.9 \times 10^{-6} \text{ m}^2/\text{s}/28.9 \times 10^{-6} \text{ m}^2/\text{s} = 0.62$ , and  $\mu/\mu_s = 1$ ,

$$\bar{\text{Sh}}_D = 2 + \left(0.4 \text{Re}_D^{1/2} + 0.06 \text{Re}_D^{2/3}\right) \text{Sc}^{0.4} = 2 + \left[0.4(838)^{1/2} + 0.06(838)^{2/3}\right] (0.62)^{0.4} = 16.0$$

$$\bar{h}_m = \bar{\text{Sh}}_D (D_{\text{AB}}/D) = 16 \left(0.289 \times 10^{-4} \text{ m}^2/\text{s}/0.001 \text{ m}\right) = 0.462 \text{ m/s}$$

$$\dot{m}_{\text{evap}} = (0.462 \text{ m/s}) \pi (0.001 \text{ m})^2 (0.0715 - 0.0091) \text{ kg/m}^3 = 9.06 \times 10^{-8} \text{ kg/s} \quad <$$

**COMMENTS:** The energy required for evaporation must be supplied by convection heat transfer from the heated air to the droplet. Hence, in actuality, the droplet temperature  $T_s$  must be less than that of the freestream air,  $T_\infty$ , which in turn will decrease from the value  $T_o$  at the heater outlet.



### PROBLEM 7.147

**KNOWN:** Diameter and temperature of sphere wetted with kerosene. Air flow conditions.

**FIND:** (a) Minimum kerosene flow rate, (b) Air temperature required to maintain wetted surface at 300K.

**SCHEMATIC:**

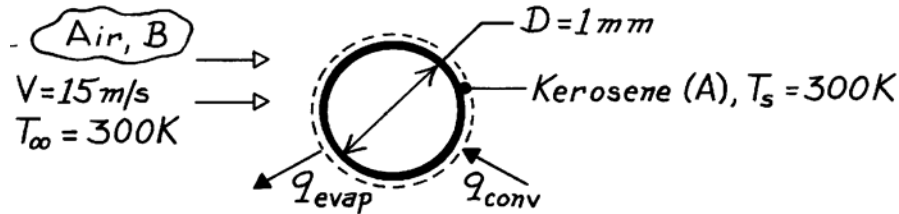

**ASSUMPTIONS:** (1) Steady-state conditions, (2) Sphere mount has a negligible influence on the flow field and hence on  $\bar{h}$ , (3) Negligible kerosene vapor concentration in free stream.

**PROPERTIES:** Table A-4, Air (300K):  $\nu = 15.89 \times 10^{-6} \text{ m}^2/\text{s}$ ,  $k = 0.0263 \text{ W/m}\cdot\text{K}$ ,  $\rho = 1.161 \text{ kg/m}^3$ ,  $Pr = 0.707$ ; Kerosene (given):  $\rho_{A,\text{sat}} = 0.015 \text{ kg/m}^3$ ,  $h_{fg} = 300 \text{ kJ/kg}$ ; Kerosene vapor-air (given):  $D_{AB} = 10^{-5} \text{ m}^2/\text{s}$ .

**ANALYSIS:** (a) The kerosene flowrate is  $\dot{n}_A = \bar{h}_m A (\rho_{A,\text{sat}} - \rho_{A,\infty})$ . Using the mass transfer analog of Eq. 7.56 and neglecting the viscosity ratio,

$$\overline{Sh}_D = 2 + \left( 0.4 Re_D^{1/2} + 0.06 Re_D^{2/3} \right) Sc^{0.4}$$

with  $Re_D = \frac{VD}{\nu} = \frac{15 \text{ m/s} \times 0.001 \text{ m}}{15.89 \times 10^{-6} \text{ m}^2/\text{s}} = 944$      $Sc = \frac{\nu}{D_{AB}} = \frac{15.89 \times 10^{-6}}{10 \times 10^{-6}} = 1.59$

$$\overline{Sh}_D = 2 + \left( 0.4 \times 944^{1/2} + 0.06 \times 944^{2/3} \right) (1.59)^{0.4} = 23.7$$

$$\bar{h}_m = \overline{Sh}_D D_{AB} / D = 23.7 \times 10^{-5} \text{ m}^2/\text{s} / 0.001 \text{ m} = 0.237 \text{ m/s}$$

$$\dot{n}_A = 0.237 \text{ m/s} \pi (10^{-3} \text{ m})^2 0.015 \text{ kg/m}^3 = 1.12 \times 10^{-8} \text{ kg/s.} \quad <$$

(b) An energy balance on the sphere yields  $\dot{n}_A h_{fg} = \bar{h} A (T_\infty - T_s)$ . Using the Whitaker correlation and neglecting the viscosity ratio,

$$\overline{Nu}_D = 2 + \left( 0.4 \times 944^{1/2} + 0.06 \times 944^{2/3} \right) (0.707)^{0.4} = 17.72$$

$$\bar{h} = \overline{Nu}_D k / D = 17.72 \times 0.0263 \text{ W/m}\cdot\text{K} / 0.001 \text{ m} = 466 \text{ W/m}^2 \cdot \text{K}$$

$$T_\infty = T_s + \frac{\dot{n}_A h_{fg}}{\bar{h} \pi D^2} = 300 \text{ K} + \frac{1.12 \times 10^{-8} \text{ kg/s} \times 3 \times 10^5 \text{ J/kg}}{466 \text{ W/m}^2 \cdot \text{K} \times \pi (0.001 \text{ m})^2}$$

$$T_\infty = 300 \text{ K} + 2.3 \text{ K} = 302.3 \text{ K} \quad <$$

or  $T_\infty - T_s = 2.3 \text{ K}$ .

**COMMENTS:** The small temperature excess (2.3K) is due to comparatively small values of  $\rho_{A,\text{sat}}$  and  $h_{fg}$  for kerosene.

### PROBLEM 7.148

**KNOWN:** Geometry and surface temperature of a tube bank with or without wetted surfaces. Temperature, velocity and flowrate associated with air in cross flow.

**FIND:** (a) Ratio of air cooling with water film to that without film, (b) Air outlet temperature and specific humidity for prescribed conditions.

**SCHEMATIC:**

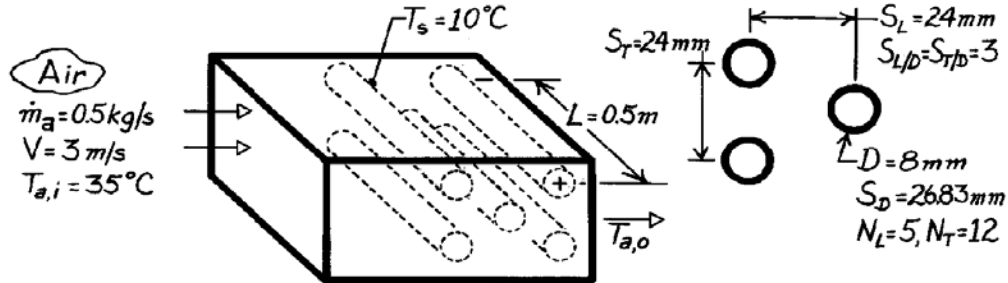

**ASSUMPTIONS:** (1) Steady-state conditions, (2) Heat and mass transfer analogy is applicable, (3) Air is dry, (4) Heat and mass transfer driving potentials are  $T_{a,i} - T_s$  and  $\rho_{A,sat}(T_s)$ , (5) Vapor has negligible effect on flowrate.

**PROPERTIES:** Table A-4, Air (assume  $\bar{T}_a \approx 305\text{K}$ ):  $\rho = 1.1448 \text{ kg/m}^3$ ,  $c_p = 1007 \text{ J/kg}\cdot\text{K}$ ,  $\nu = 16.39 \times 10^{-6} \text{ m}^2/\text{s}$ ,  $k = 0.0267 \text{ W/m}\cdot\text{K}$ ,  $\text{Pr} = 0.706$ ,  $\alpha = 23.2 \times 10^{-6} \text{ m}^2/\text{s}$ ; Table A-6, Water vapor ( $T_s = 10^\circ\text{C}$ ):  $\nu_g = 111.8 \text{ m}^2/\text{kg}$ ,  $\rho_{A,sat} = 8.94 \times 10^{-3} \text{ kg/m}^3$ ,  $h_{fg} = 2.478 \times 10^6 \text{ J/kg}$ ; Table A-8, Water vapor-air ( $T_f \approx 298\text{K}$ ):  $D_{AB} = 0.26 \times 10^{-4} \text{ m}^2/\text{s}$ ,  $\text{Sc} = (\nu/D_{AB}) = 0.630$ .

**ANALYSIS:** (a) The rate of heat loss from the air may be expressed as

$$q = \dot{m}_a c_{p,a} (T_{a,i} - T_{a,o})$$

in which case, the amount of air cooling is

$$(T_{a,i} - T_{a,o}) = \frac{q}{\dot{m}_a c_{p,a}} \quad (1)$$

Without the water film,  $q_{wo} \approx \bar{h}A(T_{a,i} - T_s)$  (2)

With the film,  $q_w \approx \bar{h}A(T_{a,i} - T_s) + \dot{m}_{\text{evap}} h_{fg}$

$$q_w \approx \bar{h}A(T_{a,i} - T_s) + \bar{h}_m A (\rho_{A,sat} - \rho_{A,\infty}) h_{fg} \quad (3)$$

where  $\rho_{A,\infty} = 0$ . Hence

$$\frac{(T_{a,i} - T_{a,o})_w}{(T_{a,i} - T_{a,o})_{wo}} \approx 1 + \frac{\bar{h}_m \rho_{A,sat} h_{fg}}{\bar{h} (T_{a,i} - T_s)}$$

or substituting from Eq. 6.60, with  $\text{Le} = \alpha/D_{AB}$  and a value of  $n = 0.33$ ,

$$\frac{(T_{a,i} - T_{a,o})_w}{(T_{a,i} - T_{a,o})_{wo}} \approx 1 + \frac{(D_{AB}/\alpha)^{0.67}}{\rho c_p} \frac{\rho_{A,sat} h_{fg}}{(T_{a,i} - T_s)} \quad <$$

Continued ...

### PROBLEM 7.148 (Cont.)

For the prescribed conditions,

$$\frac{(T_{a,i} - T_{a,o})_w}{(T_{a,i} - T_{a,o})_{wo}} \approx 1 + \frac{\left(\frac{0.26 \times 10^{-4} \text{ m}^2/\text{s}}{0.232 \times 10^{-4} \text{ m}^2/\text{s}}\right)^{0.67}}{1.145 \text{ kg/m}^3 \times 1007 \text{ J/kg} \cdot \text{K}} \times \frac{8.94 \times 10^{-3} \text{ kg/m}^3 \times 2.478 \times 10^6 \text{ J/kg}}{(35 - 10)^\circ \text{C}} \approx 1.83. \quad <$$

(b)  $T_{a,o}$  may be obtained from Eq. (1), where  $q$  is approximated by Eq. (2) or Eq. (3). With  $S_D = 26.83 \text{ mm} > (S_T + D)/2 = 16$ ,  $V_{\max}$  is at the transverse plane. Hence

$$V_{\max} = \frac{S_T}{S_T - D} V = \frac{24}{16} \times 3 \text{ m/s} = 4.5 \text{ m/s} \quad \text{Re}_{D,\max} = \frac{4.5 \text{ m/s} \times 0.008 \text{ m}}{16.39 \times 10^{-6} \text{ m}^2/\text{s}} = 2196.$$

From Tables 7.5 and 7.6,  $C_1 = 0.35$ ,  $m = 0.60$ ,  $C_2 = 0.98$  and the Zukauskas relation gives

$$\overline{\text{Nu}}_D = 0.35(0.98)(2196)^{0.6} (0.706)^{0.36} = 30.6$$

where  $(\text{Pr}/\text{Pr}_s)^{1/4}$  is 1.00. Hence

$$\bar{h} = \overline{\text{Nu}}_D k/D = 30.6(0.0267 \text{ W/m} \cdot \text{K})/0.008 \text{ m} = 102 \text{ W/m}^2 \cdot \text{K}.$$

$$\text{Also } \bar{h}_m = \bar{h} \frac{(D_{AB}/\alpha)^{0.67}}{\rho c_p} = 102 \frac{\text{W}}{\text{m}^2 \cdot \text{K}} \frac{(0.26/0.232)^{0.67}}{1.145 \text{ kg/m}^3 \times 1007 \text{ J/kg} \cdot \text{K}} = 0.0956 \text{ m/s}.$$

Hence

$$q_{\text{conv}} \approx \bar{h}A(T_{a,i} - T_s) = 102 \text{ W/m}^2 \cdot \text{K} \times \pi(0.008 \text{ m})0.5 \text{ m} \times 60(35 - 10)^\circ \text{C} = 1923 \text{ W}$$

$$q_{\text{evap}} = n_A h_{fg} = \bar{h}_m A \rho_{A,\text{sat}} h_{fg}$$

$$q_{\text{evap}} = 0.0956 \text{ m/s} \times \pi(0.008 \text{ m})0.5 \text{ m} \times 60(8.94 \times 10^{-3} \text{ kg/m}^3)2.478 \times 10^6 \text{ J/kg}$$

$$q_{\text{evap}} \approx 1597 \text{ W}.$$

With water film,

$$T_{a,o} = T_{a,i} - \frac{q_{\text{conv}} + q_{\text{evap}}}{\dot{m}_a c_{p,a}} \approx 35^\circ \text{C} - \frac{(1923 + 1597) \text{ W}}{0.5 \text{ kg/s} \times 1007 \text{ J/kg} \cdot \text{K}} = 28.0^\circ \text{C}. \quad <$$

The specific humidity of the outlet air is

$$\omega_o = \frac{n_A}{\dot{m}_a} = \frac{\bar{h}_m 60\pi DL \rho_{A,\text{sat}}}{\dot{m}_a} = \frac{0.0956 \text{ m/s}(60\pi)(0.008 \text{ m})0.5 \text{ m}(8.94 \times 10^{-3} \text{ kg/m}^3)}{0.5 \text{ kg/s}} = 0.00129. \quad <$$

**COMMENTS:** (1) Enhancement of air cooling by evaporation is significant ( $T_{a,o} = T_{a,i} - q_{\text{conv}}/\dot{m}_a c_{p,a} \approx 31.1^\circ \text{C}$  without the film). (2) Small value of  $\omega_o$  justifies neglecting effect of evaporation on  $\dot{m}_a$ . (3)  $q_{\text{conv}}$  has been overestimated by using  $(T_{a,i} - T_s)$  as the driving potential for convection heat transfer. A more accurate determination involves  $\Delta T_{\ell m}$  rather than  $(T_{a,i} - T_s)$ . (4) Apparently the air properties were evaluated at an appropriate  $\bar{T}_a$ .

### PROBLEM 7.149

**KNOWN:** Dimensions of slot jet array. Jet exit velocity and temperature. Temperature of paper.

**FIND:** Drying rate per unit surface area.

**SCHEMATIC:**

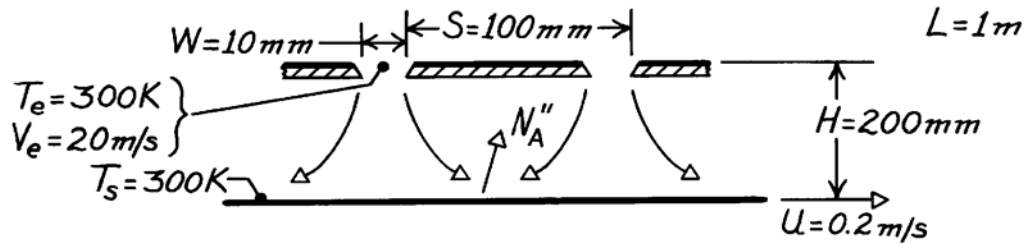

**ASSUMPTIONS:** (1) Applicability of heat and mass transfer analogy, (2) Paper motion has negligible effect on convection ( $U \ll V_e$ ).

**PROPERTIES:** Table A-4, Air (300 K, 1 atm):  $\nu = 15.89 \times 10^{-6} \text{ m}^2/\text{s}$ ; Table A-6, Saturated water (300 K):  $\rho_{A,\text{sat}} = \nu_g^{-1} = 0.0256 \text{ kg/m}^3$ ; Table A-8, Water vapor-air (300 K):  $D_{AB} = 0.26 \times 10^{-4} \text{ m}^2/\text{s}$ ,  $Sc = 0.61$ .

**ANALYSIS:** The mass evaporation flux is

$$n_A'' = \bar{h}_m (\rho_{A,s} - \rho_{A,e}) = \bar{h}_m \rho_{A,\text{sat}}$$

For an array of slot nozzles,

$$\frac{\bar{Sh}}{Sc^{0.42}} = \frac{2}{3} A_{r,o}^{3/4} \left( \frac{2 Re}{A_r / A_{r,o} + A_{r,o} / A_r} \right)^{2/3}$$

where

$$A_r = W/S = 0.1$$

$$A_{r,o} = \left\{ 60 + 4 \left[ \left( \frac{H}{2W} \right) - 2 \right]^2 \right\}^{-1/2} = \{ 60 + 4(64) \}^{-1/2} = 0.0563$$

$$Re = \frac{V_e (2W)}{\nu} = \frac{20 \text{ m/s} (0.02 \text{ m})}{15.89 \times 10^{-6} \text{ m}^2/\text{s}} = 25,173.$$

Hence

$$\frac{\bar{Sh}}{Sc^{0.42}} = 0.667 (0.0563)^{3/4} \left( \frac{50,346}{1.776 + 0.563} \right)^{2/3} = 59.6$$

$$\bar{h}_m = \frac{D_{AB}}{2W} 59.6 Sc^{0.42} = \frac{0.26 \times 10^{-4} \text{ m}^2/\text{s}}{0.02 \text{ m}} 59.6 (0.61)^{0.42} = 0.063 \text{ m/s}.$$

The evaporative flux is then

$$n_A'' = 0.063 \text{ m/s} (0.0256 \text{ kg/m}^3) = 0.0016 \text{ kg/s} \cdot \text{m}^2. \quad \leftarrow$$

**COMMENTS:** The mass fraction of water vapor to air leaving the sides of the dryer is

$n_A'' (S \times L) / \rho_{\text{air}} V_e (W \times L) = 7 \times 10^{-4}$ . Hence, the assumption of dry air throughout the dryer is reasonable.

### PROBLEM 8.1

**KNOWN:** Flowrate and temperature of water in fully developed flow through a tube of prescribed diameter.

**FIND:** Maximum velocity and pressure gradient.

**SCHEMATIC:**



**ASSUMPTIONS:** (1) Steady-state conditions, (2) Isothermal flow, (3) Horizontal tube.

**PROPERTIES:** Table A-6, Water (300 K):  $\rho = 998 \text{ kg/m}^3$ ,  $\mu = 855 \times 10^{-6} \text{ N}\cdot\text{s/m}^2$ .

**ANALYSIS:** From Eq. 8.6,

$$\text{Re}_D = \frac{4\dot{m}}{\pi D \mu} = \frac{4 \times 0.01 \text{ kg/s}}{\pi (0.025 \text{ m}) 855 \times 10^{-6} \text{ kg/m}\cdot\text{s}} = 596.$$

Hence the flow is laminar and the velocity profile is given by Eq. 8.15,

$$\frac{u(r)}{u_m} = 2 \left[ 1 - (r/r_0)^2 \right].$$

The maximum velocity is therefore at  $r = 0$ , the centerline, where

$$u(0) = 2 u_m.$$

From Eq. 8.5

$$u_m = \frac{\dot{m}}{\rho \pi D^2 / 4} = \frac{4 \times 0.01 \text{ kg/s}}{998 \text{ kg/m}^3 \times \pi (0.025 \text{ m})^2} = 0.020 \text{ m/s},$$

hence

$$u(0) = 0.041 \text{ m/s}.$$

Combining Eqs. 8.16 and 8.19, the pressure gradient is

$$\frac{dp}{dx} = -\frac{64}{\text{Re}_D} \frac{\rho u_m^2}{2D}$$

$$\frac{dp}{dx} = -\frac{64}{596} \times \frac{998 \text{ kg/m}^3 (0.020 \text{ m/s})^2}{2 \times 0.025 \text{ m}} = -0.86 \text{ kg/m}^2 \cdot \text{s}^2$$

$$\frac{dp}{dx} = -0.86 \text{ N/m}^2 \cdot \text{m} = -0.86 \times 10^{-5} \text{ bar/m}.$$

<

## PROBLEM 8.2

**KNOWN:** Temperature and mean velocity of water flow through a cast iron pipe of prescribed length and diameter.

**FIND:** Pressure drop.

**SCHEMATIC:**

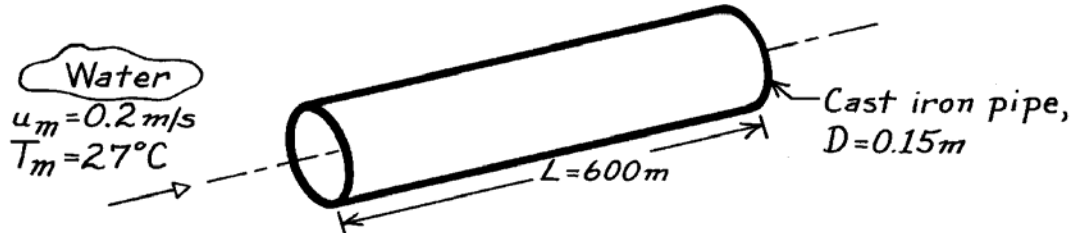

**ASSUMPTIONS:** (1) Steady-state conditions, (2) Fully developed flow, (3) Constant properties.

**PROPERTIES:** Table A-6, Water (300 K):  $\rho = 997\text{ kg/m}^3$ ,  $\mu = 855 \times 10^{-6}\text{ N}\cdot\text{s/m}^2$ .

**ANALYSIS:** From Eq. 8.22, the pressure drop is

$$\Delta p = f \frac{\rho u_m^2}{2D} L.$$

With

$$\text{Re}_D = \frac{\rho u_m D}{\mu} = \frac{997\text{ kg/m}^3 \times 0.2\text{ m/s} \times 0.15\text{ m}}{855 \times 10^{-6}\text{ N}\cdot\text{s/m}^2} = 3.50 \times 10^4$$

the flow is turbulent and with  $e = 2.6 \times 10^{-4}\text{ m}$  for cast iron (see Fig. 8.3), it follows that  $e/D = 1.73 \times 10^{-3}$  and from Eq. 8.20 (or Fig. 8.3)

$$\frac{1}{\sqrt{f}} = -2.0 \log \left[ \frac{e/D}{3.7} + \frac{2.51}{\text{Re}_D \sqrt{f}} \right] \quad f = 0.027$$

Hence,

$$\Delta p = 0.027 \frac{997\text{ kg/m}^3 (0.2\text{ m/s})^2}{2 \times 0.15\text{ m}} (600\text{ m})$$

$$\Delta p = 2154\text{ kg/s}^2 \cdot \text{m} = 2154\text{ N/m}^2$$

$$\Delta p = 0.0215\text{ bar.} \quad \leftarrow$$

**COMMENTS:** For the prescribed geometry,  $L/D = (600/0.15) = 4000 \gg (x_{fd,h}/D)_{\text{turb}} \approx 10$ , and the assumption of fully developed flow throughout the pipe is justified.

### PROBLEM 8.3

**KNOWN:** Temperature and velocity of water flow in a pipe of prescribed dimensions.

**FIND:** Pressure drop and pump power requirement for (a) a smooth pipe, (b) a cast iron pipe with a clean surface, and (c) smooth pipe for a range of mean velocities 0.05 to 1.5 m/s.

**SCHEMATIC:**

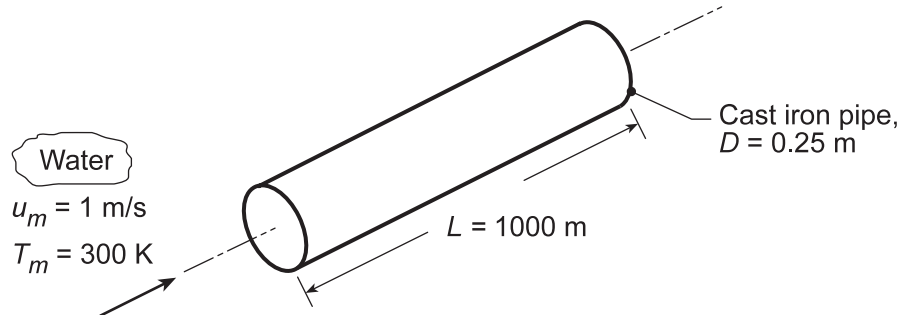

**ASSUMPTIONS:** (1) Steady, fully developed flow.

**PROPERTIES:** Table A.6, Water (300 K):  $\rho = 997 \text{ kg/m}^3$ ,  $\mu = 855 \times 10^{-6} \text{ N}\cdot\text{s/m}^2$ ,  $\nu = \mu/\rho = 8.576 \times 10^{-7} \text{ m}^2/\text{s}$ .

**ANALYSIS:** From Eq. 8.22a and 8.22b, the pressure drop and pump power requirement are

$$\Delta p = f \frac{\rho u_m^2}{2D} L \quad P = \Delta p \dot{V} = \Delta p \left( \pi D^2 / 4 \right) u_m \quad (1,2)$$

The friction factor,  $f$ , may be determined from Figure 8.3 or Eq. 8.20 for different relative roughness,  $e/D$ , surfaces or from Eq. 8.21 for the smooth condition,  $3000 \leq \text{Re}_D \leq 5 \times 10^6$ ,

$$f = \left( 0.790 \ln(\text{Re}_D) - 1.64 \right)^{-2} \quad (3)$$

where the Reynolds number is

$$\text{Re}_D = \frac{u_m D}{\nu} = \frac{1 \text{ m/s} \times 0.25 \text{ m}}{8.576 \times 10^{-7} \text{ m}^2/\text{s}} = 2.915 \times 10^5 \quad (4)$$

(a) *Smooth surface:* from Eqs. (3), (1) and (2),

$$f = \left( 0.790 \ln(2.915 \times 10^5) - 1.64 \right)^{-2} = 0.01451$$

$$\Delta p = 0.01451 \left( 997 \text{ kg/m}^3 \times 1 \text{ m}^2/\text{s}^2 / 2 \times 0.25 \text{ m} \right) 1000 \text{ m} = 2.89 \times 10^4 \text{ kg/s}^2 \cdot \text{m} = 0.289 \text{ bar} <$$

$$P = 2.89 \times 10^4 \text{ N/m}^2 \left( \pi \times 0.25^2 \text{ m}^2 / 4 \right) 1 \text{ m/s} = 1418 \text{ N} \cdot \text{m/s} = 1.42 \text{ kW} <$$

(b) *Cast iron clean surface:* with  $e = 260 \mu\text{m}$ , the relative roughness is  $e/D = 260 \times 10^{-6} \text{ m} / 0.25 \text{ m} = 1.04 \times 10^{-3}$ . From Figure 8.3 or Eq. 8.20 with  $\text{Re}_D = 2.92 \times 10^5$ , find  $f = 0.021$ . Hence,

$$\Delta p = 0.402 \text{ bar} \quad P = 1.97 \text{ kW} <$$

(c) *Smooth surface:* Using IHT with the expressions of part (a), the pressure drop and pump power requirement as a function of mean velocity,  $u_m$ , for the range  $0.05 \leq u_m \leq 1.5 \text{ m/s}$  are computed and plotted below.

Continued...





## PROBLEM 8.4

**KNOWN:** Number, diameter and length of tubes and flow rate for an engine oil cooler.

**FIND:** Pressure drop and pump power (a) for flow rate of 24 kg/s and (b) as a function of flow rate for the range  $10 \leq \dot{m} \leq 30$  kg/s.

**SCHEMATIC:**

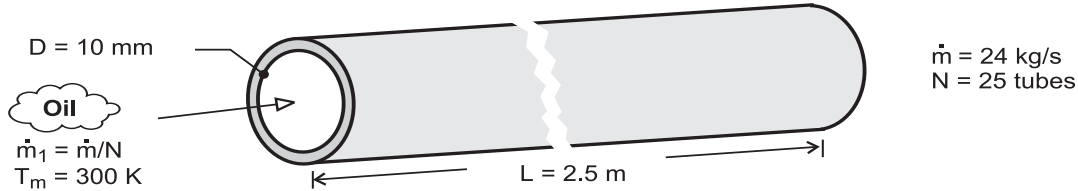

**ASSUMPTIONS:** (1) Fully developed flow throughout the tubes.

**PROPERTIES:** Table A.5, Engine oil (300 K):  $\rho = 884$  kg/m<sup>3</sup>,  $\mu = 0.486$  kg/s·m.

**ANALYSIS:** (a) Considering flow through a single tube, find

$$\text{Re}_D = \frac{4\dot{m}}{\pi D \mu} = \frac{4(24 \text{ kg/s})}{25\pi(0.010 \text{ m})0.486 \text{ kg/s}\cdot\text{m}} = 251.5 \quad (1)$$

Hence, the flow is laminar and from Equation 8.19,

$$f = \frac{64}{\text{Re}_D} = \frac{64}{251.5} = 0.2545. \quad (2)$$

With

$$u_m = \frac{\dot{m}_1}{\rho(\pi D^2/4)} = \frac{(24/25) \text{ kg/s}(4)}{(884 \text{ kg/m}^3)\pi(0.010 \text{ m})^2} = 13.8 \text{ m/s} \quad (3)$$

Equation 8.22a yields

$$\Delta p = f \frac{\rho u_m^2}{2D} L = 0.2545 \frac{(884 \text{ kg/m}^3)(13.8 \text{ m/s})^2}{2(0.010 \text{ m})} 2.5 \text{ m} = 5.38 \times 10^6 \text{ N/m}^2 = 53.8 \text{ bar} \quad (4) \ll$$

The pump power requirement from Equation 8.22b,

$$P = \Delta p \cdot \dot{V} = \Delta p \cdot \frac{\dot{m}}{\rho} = 5.38 \times 10^6 \text{ N/m}^2 \frac{24 \text{ kg/s}}{884 \text{ kg/m}^3} = 1.459 \times 10^5 \text{ N}\cdot\text{m/s} = 146 \text{ kW}. \quad (5) \ll$$

(b) Using IHT with the expressions of part (a), the pressure drop and pump power requirement as a function of flow rate,  $\dot{m}$ , for the range  $10 \leq \dot{m} \leq 30$  kg/s are computed and plotted below.

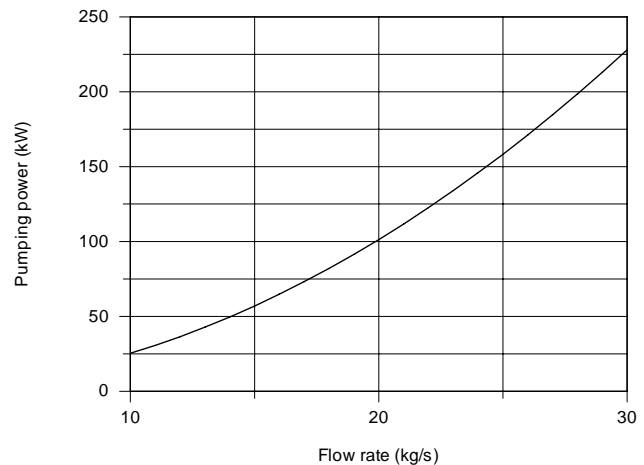
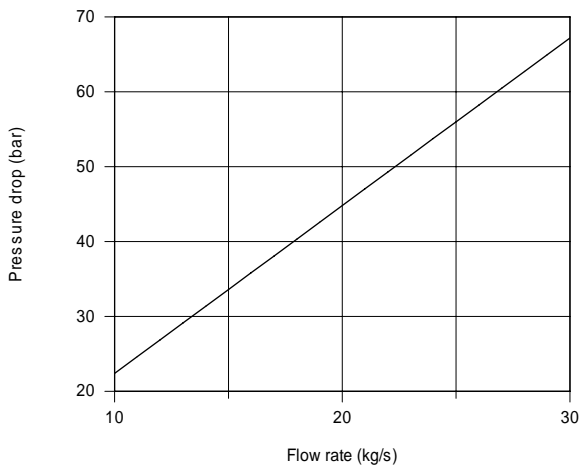

Continued...

## PROBLEM 8.4 (Cont.)

In the plot above, note that the pressure drop is linear with the flow rate since, from Eq. (2), the friction factor is inversely dependent upon mean velocity. The pump power, however, is quadratic with the flow rate.

**COMMENTS:** (1) If there is a hydrodynamic entry region, the average friction factor for the entire tube length would exceed the fully developed value, thereby increasing  $\Delta p$  and  $P$ .

(2) The *IHT Workspace* used to generate the graphical results follows.

```

/* Results: base case, part (a)
P_kW      ReD      deltap_bar      f      mu      rho      um      D      N
mdot
145.9     251.5     53.75           0.2545  0.486   884.1   13.83   0.01   25
      24           */

// Reynolds number and friction factor
ReD = 4 * mdot1 / (pi * D * mu) // Reynolds number, Eq (1)
f = 64 / ReD // Friction factor, laminar flow, Eq. 8.19, Eq. (2)

// Average velocity and flow rate
mdot1 = rho * Ac * um // Flow rate, kg/s; single tube
mdot = mdot1 * N // Total flow rate, kg/s; N tubes
Ac = pi * D^2 / 4 // Tube cross-sectional area, m^2

// Pressure drop and power
deltap = f * rho * um^2 * L / (2 * D) // Pressure drop, N/m^2
deltap_bar = deltap * 1e-5 // Pressure drop, bar
P = deltap * mdot / rho // Power, W
P_kW = P / 1000 // Power, kW

// Input variables
D = 0.01 // Diameter, m
mdot = 24 // Total flow rate, kg/s
L = 2.5 // Tube length, m
N = 25 // Number of tubes
Tm = 300 // Mean temperature of oil, K

// Engine Oil property functions : From Table A.5
rho = rho_T("Engine Oil",Tm) // Density, kg/m^3
mu = mu_T("Engine Oil",Tm) // Viscosity, N-s/m^2

```

## PROBLEM 8.5

**KNOWN:** The x-momentum equation for fully developed laminar flow in a parallel-plate channel

$$\frac{dp}{dx} = \text{constant} = \mu \frac{d^2u}{dy^2}$$

**FIND:** Following the same approach as for the circular tube in Section 8.1: (a) Show that the velocity profile,  $u(y)$ , is parabolic of the form

$$u(y) = \frac{3}{2} u_m \left[ 1 - \frac{y^2}{(a/2)^2} \right]$$

where  $u_m$  is the mean velocity expressed as

$$u_m = \frac{a^2}{12\mu} \left( -\frac{dP}{dx} \right)$$

and  $-dp/dx = \Delta p/L$  where  $\Delta p$  is the pressure drop across the channel of length  $L$ ; (b) Write the expression defining the friction factor,  $f$ , using the hydraulic diameter as the characteristic length,  $D_h$ ; What is the hydraulic diameter for the parallel-plate channel? (c) The friction factor is estimated from the expression  $f = C/Re_{D_h}$  where  $C$  depends upon the flow cross-section as shown in Table 8.1;

What is the coefficient  $C$  for the parallel-plate channel ( $b/a \rightarrow \infty$ )? (d) Calculate the mean air velocity and the Reynolds number for air at atmospheric pressure and 300 K in a parallel-plate channel with separation of 5 mm and length of 100 mm subjected to a pressure drop of  $\Delta p = 3.75 \text{ N/m}^2$ ; Is the assumption of fully developed flow reasonable for this application? If not, what effect does this have on the estimate for  $u_m$ ?

**SCHEMATIC:**

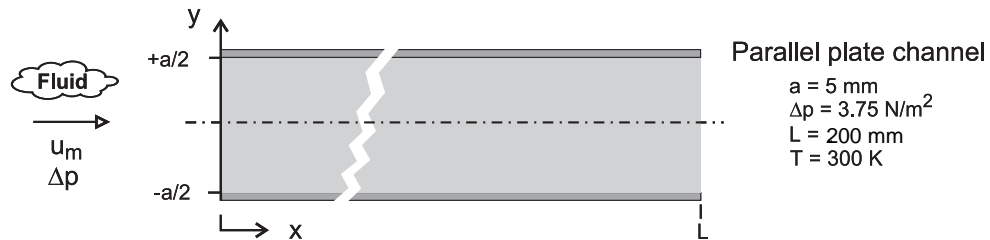

**ASSUMPTIONS:** (1) Fully developed laminar flow, (2) Parallel-plate channel,  $a \ll b$ .

**PROPERTIES:** Table A-4, Air (300 K, 1 atm):  $\mu = 184.6 \times 10^{-7} \text{ N}\cdot\text{s/m}^2$ ,  $\nu = 15.89 \times 10^{-6} \text{ m}^2/\text{s}$ .

**ANALYSIS:** (a) The x-momentum equation for fully developed laminar flow is

$$\mu \left( \frac{d^2u}{dy^2} \right) = \frac{dp}{dx} = \text{constant} \quad (1)$$

Since the longitudinal pressure gradient is constant, separate variables and integrate twice,

$$\frac{d}{dy} \left( \frac{du}{dy} \right) = \frac{1}{\mu} \left( \frac{dp}{dx} \right) \quad \frac{du}{dy} = \frac{1}{\mu} \left( \frac{dp}{dx} \right) y + C_1$$

$$u = \frac{1}{2\mu} \left( \frac{dp}{dx} \right) y^2 + C_1 y + C_2$$

Continued ...

### PROBLEM 8.5 (Cont.)

The integration constants are determined from the boundary conditions,

$$\left. \frac{du}{dy} \right|_{y=0} = 0 \quad u(a/2) = 0$$

to find

$$C_1 = 0 \quad C_2 = -\frac{1}{2\mu} \left( \frac{dp}{dx} \right) (a/2)^2$$

giving

$$u(y) = -\frac{(a/2)^2}{2\mu} \left( \frac{dp}{dx} \right) \left[ 1 - \frac{y^2}{(a/2)^2} \right] \quad (2)$$

The mean velocity is

$$u_m = \frac{2}{a} \int_0^{a/2} u(y) dy = -\frac{2}{a} \frac{(a/2)^2}{2\mu} \left( \frac{dp}{dx} \right) \left[ y - \frac{y^3/3}{(a/2)^2} \right]_0^{a/2}$$

$$u_m = \frac{a^2}{12\mu} \left( -\frac{dp}{dx} \right) \quad (3)$$

Substituting Eq. (3) for  $dp/dx$  into Eq. (2) find the velocity distribution in terms of the mean velocity

$$u(y) = \frac{3}{2} u_m \left[ 1 - \frac{y^2}{(a/2)^2} \right] \quad < \quad (4)$$

(b) The friction factor follows from its definition, Eq. 8.16,

$$f = \frac{-(dp/dx) D_h}{\rho \cdot u_m^2 / 2} \quad (5)$$

where the hydraulic diameter for the channel using Eq. 8.66 is

$$D_h = \frac{4 \cdot A_c}{P} = \frac{4(a \times b)}{2(a+b)} = 2a \quad < \quad (6)$$

since  $a \ll b$ .

(c) Substituting for the pressure gradient, Eq. (3), and rearranging, find using Eq. (6),

$$f = \frac{u_m}{a^2 / 12\mu} \frac{D_h}{\rho u_m^2 / 2} = \frac{96}{u_m D_h / \nu} = \frac{96}{\text{Re}_{D_h}} \quad < \quad (7)$$

where the Reynolds number is

$$\text{Re}_{D_h} = u_m D_h / \nu \quad (8)$$

Continued ...

### PROBLEM 8.5 (Cont.)

This result is in agreement with Table 8.1 for the cross-section with  $b/a \rightarrow \infty$  where

$$C = 96.$$

<

(d) For the conditions shown in the schematic, with air properties evaluated at 300 K, using Eqs. (3) and (8), find

$$u_m = \frac{(0.005\text{m})^2}{12 \times 184.6 \times 10^{-7} \text{ N} \cdot \text{s} / \text{m}^2} \left( \frac{3.75 \text{ N} / \text{m}^2}{0.200\text{m}} \right) = 2.12 \text{ m/s}$$

$$\text{Re}_D = \frac{2.12 \text{ m/s} \times 2 \times 0.005 \text{ m}}{15.89 \times 10^{-6} \text{ m}^2 / \text{s}} = 1332$$

The flow is laminar since  $\text{Re}_{Dh} < 2300$ , and from Eq. 8.3, the laminar entry length is

$$\left( \frac{x_{fd,h}}{D_h} \right)_{\text{lam}} = 0.05 \text{Re}_{Dh}$$

$$x_{fd,h} = 2 \times 0.005 \text{ m} \times 0.05 \times 1332 = 0.67 \text{ m}$$

We conclude that the flow is not fully developed, and the friction factor in the entry region will be higher than for fully developed conditions. Hence, for the same pressure drop, the mean velocity will be less than our estimate.

## PROBLEM 8.6

**KNOWN:** Water, engine oil and NaK flowing in a 20 mm diameter tube, temperature of the fluids.

**FIND:** (a) The mean velocity as well as hydrodynamic and thermal entrance lengths, for a flow rate of 0.01 kg/s and mean temperature of 366 K, (b) The mass flow rate as well as hydrodynamic and thermal entrance lengths for water and oil at a mean velocity of 0.02 m/s at mean temperatures of 300 and 400 K.

**SCHEMATIC:**

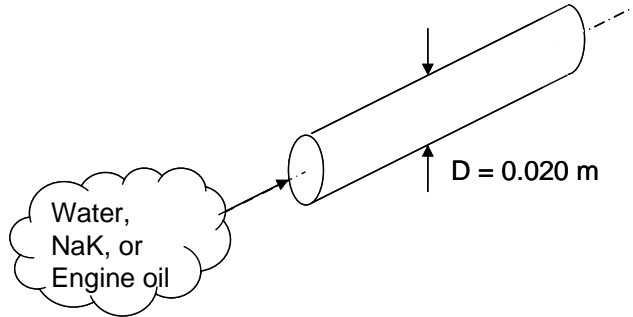

**ASSUMPTIONS:** (1) Constant properties.

**PROPERTIES:**

Liquid	T(K)	Table	$\rho(\text{kg/m}^3)$	$\mu(\text{N}\cdot\text{s/m}^2)$	$\nu(\text{m}^2/\text{s})$	Pr
Water	300	A.6	997	$855 \times 10^{-6}$	-	5.83
	366	A.6	963	$303 \times 10^{-6}$	-	1.89
	400	A.6	937	$217 \times 10^{-6}$	-	1.34
Oil	300	A.5	884	$48.6 \times 10^{-2}$	-	6400
	366	A.5	844	$2.12 \times 10^{-2}$	-	338
	400	A.5	825	$0.874 \times 10^{-2}$	-	152
NaK	366	A.7	849	-	$5.797 \times 10^{-7}$	0.019

**ANALYSIS:** (a) The mean velocity is given by

$$u_m = \dot{m} / \rho A_c = 0.01 \text{ kg/s} / [\rho \pi (0.020 \text{ m})^2 / 4] = 31.8 \text{ kg/s} \cdot \text{m}^2 / \rho \quad (1)$$

The Reynolds number is

$$\text{Re}_D = \frac{4\dot{m}}{\pi D \mu} = \frac{4 \times 0.01 \text{ kg/s}}{\pi (0.020 \text{ m}) \mu} = \frac{0.636 \text{ kg/s} \cdot \text{m}}{\mu} \quad (2)$$

The hydrodynamic entrance length is

$$\begin{aligned} x_{fd,h} &= 0.05 \text{Re}_D D = 0.05 \times \frac{0.636 \text{ kg/s} \cdot \text{m}}{\mu} \times (0.020 \text{ m}) \\ &= \frac{636 \times 10^{-6} \text{ kg/s} \cdot \text{m}}{\mu} \end{aligned} \quad (3)$$

Continued...

**PROBLEM 8.6 (Cont.)**

The thermal entrance length is

$$\begin{aligned}
 x_{fd,t} &= 0.05Re_D DPr = x_{fd,h} Pr \\
 &= \frac{636 \times 10^{-6} \text{ kg/s} \cdot \text{m}}{\mu} Pr
 \end{aligned}
 \tag{4}$$

Solving Equations (1), (3) and (4) yields

Liquid	$u_m$ (m/s)	$x_{fd,h}$ (m)	$x_{fd,t}$ (m)
water	0.033	2.1	3.97
engine oil	0.038	0.030	10.1
NaK	0.037	1.3	0.025

where, for the NaK,  $\mu$  is found from the definition

$$\mu = \nu\rho = 5.797 \times 10^{-7} \text{ m}^2/\text{s} \times 849 \text{ kg/m}^3 = 492 \times 10^{-6} \text{ N} \cdot \text{s/m}^2$$

(b) The mass flow rate is given by

$$\dot{m} = \rho A_c u_m = \frac{0.02 \text{ m/s} \times \pi \times (0.020 \text{ m})^2}{4} \rho = 6.28 \times 10^{-6} \frac{\text{m}^3}{\text{s}} \rho \tag{5}$$

The Reynolds number is

$$Re_D = \frac{4\dot{m}}{\pi D\mu} = \frac{4 \times 6.28 \times 10^{-6} \text{ m}^3/\text{s} \times \rho}{\pi(0.020 \text{ m})\mu} = 400 \times 10^{-6} \text{ m}^2/\text{s} \times (\rho/\mu) \tag{6}$$

The hydrodynamic entrance length is

$$\begin{aligned}
 x_{fd,h} &= 0.05Re_D D = 0.05 \times 400 \times 10^{-6} \text{ m}^2/\text{s} \times 0.02 \text{ m} (\rho/\mu) \\
 x_{fd,h} &= 400 \times 10^{-9} \text{ m}^3/\text{s} (\rho/\mu)
 \end{aligned}
 \tag{7}$$

The thermal entrance length is

$$x_{fd,t} = x_{fd,h} Pr = 400 \times 10^{-9} \text{ m}^3/\text{s} (\rho/\mu) Pr \tag{8}$$

Solving Equations (5), (7) and (8) yields

Liquid	T (k)	$\dot{m}$ (kg/s)	$x_{fd,h}$ (m)	$x_{fd,t}$ (m)
Water	300	0.0063	0.464	2.72
Water	400	0.0059	1.72	2.30
Engine Oil	300	0.0056	$7.27 \times 10^{-4}$	4.65
Engine Oil	400	0.0052	$37.7 \times 10^{-3}$	5.74

**COMMENTS:** (1) As the momentum and thermal diffusivities approach similar values ( $Pr \rightarrow 1$ )  $x_{fd,h}/x_{fd,t} \rightarrow 1$ . (2) Note the variation of  $x_{fd,h}/x_{fd,t}$  with  $Pr$  for large and small values of the Prandtl number. (c) The Reynolds number associated with the oil is very small. Buoyancy forces are likely to be significant and may induce secondary fluid motion which, in turn, may increase the convection heat transfer coefficients. We will treat buoyancy effects in Chapter 9.

## PROBLEM 8.7

**KNOWN:** Velocity and temperature profiles for laminar flow in a tube of radius  $r_o = 10$  mm.

**FIND:** Mean (or bulk) temperature,  $T_m$ , at this axial position.

**SCHEMATIC:**

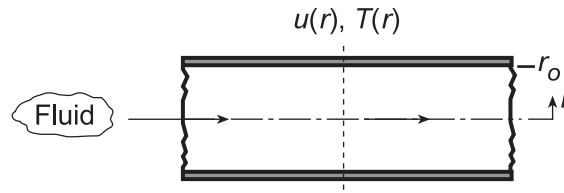

**ASSUMPTIONS:** (1) Laminar incompressible flow, (2) Constant properties.

**ANALYSIS:** The prescribed velocity and temperature profiles, (m/s and K, respectively) are

$$u(r) = 0.1 [1 - (r/r_o)^2] \quad T(r) = 344.8 + 75.0 (r/r_o)^2 - 18.8 (r/r_o)^4 \quad (1,2)$$

For incompressible flow with constant  $c_v$  in a circular tube, from Eq. 8.26, the mean temperature and  $u_m$ , the mean velocity, from Eq. 8.8 are, respectively,

$$T_m = \frac{2}{u_m r_o^2} \int_0^{r_o} u(r) \cdot T(r) \cdot r \cdot dr \quad u_m = \frac{2}{r_o^2} \int_0^{r_o} u(r) \cdot r \cdot dr \quad (3,4)$$

Substituting the velocity profile, Eq. (1), into Eq. (4) and integrating, find

$$u_m = \frac{2}{r_o^2} \int_0^{r_o} 0.1 [1 - (r/r_o)^2] (r/r_o) d(r/r_o) = 2 \left\{ 0.1 \left[ \frac{1}{2} (r/r_o)^2 - \frac{1}{4} (r/r_o)^4 \right] \right\}_0^1 = 0.05 \text{ m/s}$$

Substituting the profiles and  $u_m$  into Eq. (3), find

$$T_m = \frac{2}{(0.05 \text{ m/s}) r_o^2} \int_0^{r_o} \left\{ 0.1 [1 - (r/r_o)^2] \right\} \left\{ 344.8 + 75.0 (r/r_o)^2 - 18.8 (r/r_o)^4 \right\} \cdot (r/r_o) \cdot d(r/r_o)$$

$$T_m = 4 \int_0^1 \left\{ [344.8 (r/r_o) + 75.0 (r/r_o)^3 - 18.8 (r/r_o)^5] - [344.8 (r/r_o)^3 + 75.0 (r/r_o)^5 - 18.8 (r/r_o)^7] \right\} d(r/r_o)$$

$$T_m = 4 \{ [172.40 + 18.75 - 3.13] - [86.20 + 12.50 - 2.35] \} = 367 \text{ K} \quad <$$

The velocity and temperature profiles appear as shown below. Do the values of  $u_m$  and  $T_m$  found above compare with their respective profiles as you thought? Is the fluid being heated or cooled?

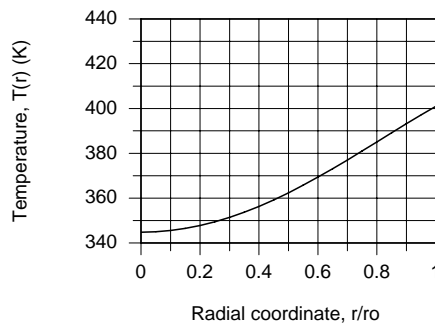
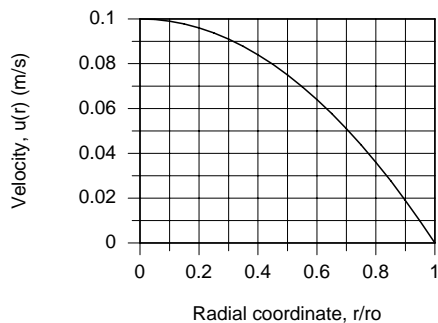



## PROBLEM 8.8

**KNOWN:** Velocity and temperature profiles for laminar flow in a parallel plate channel.

**FIND:** Mean velocity,  $u_m$ , and mean (or bulk) temperature,  $T_m$ , at this axial position. Plot the velocity and temperature distributions. Comment on whether values of  $u_m$  and  $T_m$  appear reasonable.

**SCHEMATIC:**

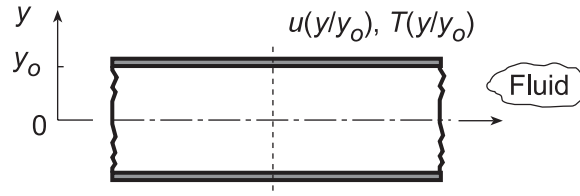

**ASSUMPTIONS:** (1) Laminar incompressible flow, (2) Constant properties.

**ANALYSIS:** The prescribed velocity and temperature profiles (m/s and °C, respectively) are

$$u(y) = 0.75 \left[ 1 - (y/y_o)^2 \right] \quad T(y) = 5.0 + 95.66(y/y_o)^2 - 47.83(y/y_o)^4 \quad (1,2)$$

The mean velocity,  $u_m$ , follows from its definition, Eq. 8.7,

$$\dot{m} = \rho A_c u_m = \rho \int_{A_c} u(y) \cdot dA_c$$

where the flow cross-sectional area is  $dA_c = 1 \cdot dy$ , and  $A_c = 2y_o$ ,

$$u_m = \frac{1}{A_c} \int_{A_c} u(y) \cdot dy = \frac{1}{2y_o} \int_{-y_o}^{+y_o} u(y) dy \quad (3)$$

$$u_m = \frac{1}{2y_o} \cdot y_o \int_{-1}^{+1} 0.75 \left[ 1 - (y/y_o)^2 \right] d(y/y_o)$$

$$u_m = 1/2 \left\{ 0.75 \left[ (y/y_o) - 1/3 (y/y_o)^3 \right] \right\}_{-1}^{+1}$$

$$u_m = 1/2 \times 0.75 \{ [1 - 1/3] - [-1 + 1/3] \} = 1/2 \times 0.75 \times 4/3 = 2/3 \times 0.75 = 0.50 \text{ m/s} \quad <$$

The mean temperature,  $T_m$ , follows from its definition, Eq. 8.25,

$$\dot{E}_t = \dot{m} c_v T_m \quad \text{where} \quad \dot{m} = \rho A_c u_m$$

$$\rho A_c u_m c_p T_m = \rho c_p \int_{A_c} u(y) \cdot T(y) dA_c$$

Hence, substituting velocity and temperature profiles,

$$T_m = \frac{1}{u_m A_c} \int_{-y_o}^{+y_o} u(y) \cdot T(y) dy \quad (4)$$

$$T_m = \frac{1}{(0.5 \text{ m/s}) 2y_o} y_o \int_{-1}^{+1} \left\{ 0.75 \left[ 1 - (y/y_o)^2 \right] \right\} \left\{ 5.0 + 95.66(y/y_o)^2 - 47.83(y/y_o)^4 \right\} d(y/y_o)$$

$$T_m = \frac{0.75}{0.5 \times 2} \left\{ \left[ 5(y/y_o) + 31.89(y/y_o)^3 - 9.57(y/y_o)^5 \right] - \left[ 1.67(y/y_o)^3 + 19.13(y/y_o)^5 - 6.83(y/y_o)^7 \right] \right\}_{-1}^{+1}$$

$$T_m = \frac{0.75}{0.5 \times 2} \{ [27.32 - 13.97] - [-27.32 - (-13.97)] \} = 20.0^\circ \text{C} \quad <$$

Continued...

### PROBLEM 8.8 (Cont.)

The velocity and temperature profiles along with the  $u_m$  and  $T_m$  values are plotted below.

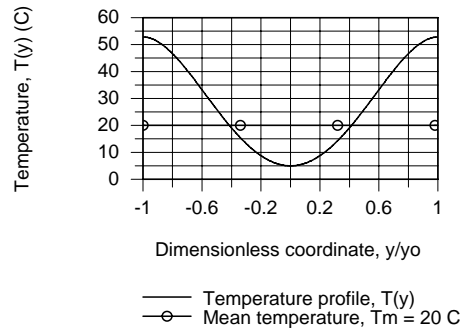
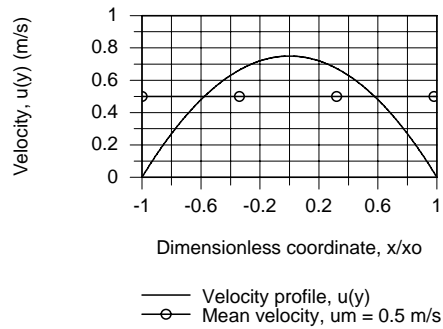

For the velocity profile, the mean velocity is  $2/3$  that of the centerline velocity,  $u_m = 2u(0)/3$ . Note that the areas above and below the  $u_m$  line appear to be equal. Considering the temperature profile, we'd expect the mean temperature to be closer to the centerline temperature since the velocity profile weights the integral toward the centerline.

**COMMENTS:** The integrations required to obtain  $u_m$  and  $T_m$ , Eqs. (3) and (4), could also be performed using the intrinsic function *INTEGRAL* ( $y,x$ ) in the *IHT Workspace*.

## PROBLEM 8.9

**KNOWN:** Flow rate and properties of oil flowing in pipe. Dimensions of pipe.

**FIND:** Pressure drop, flow work, temperature rise caused by flow work.

**SCHEMATIC:**

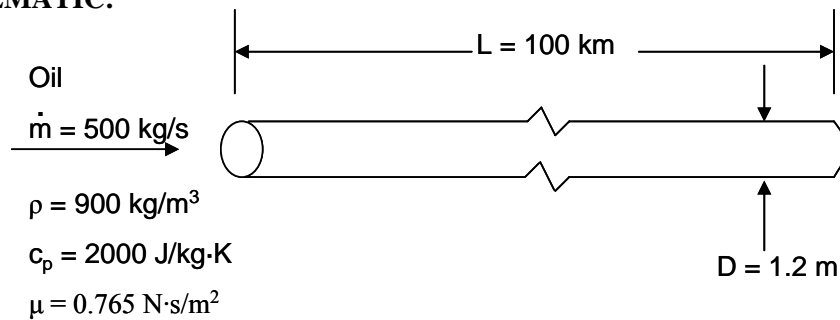

**ASSUMPTIONS:** (1) Steady-state, (2) Incompressible flow, (3) Negligible kinetic and potential energy changes, (4) No work *other than* flow work.

**ANALYSIS:** We begin by determining whether the flow is laminar or turbulent. From Equation 8.6

$$Re_d = \frac{4\dot{m}}{\pi D \mu} = \frac{4 \times 500 \text{ kg/s}}{\pi \times 1.2 \text{ m} \times 0.765 \text{ N}\cdot\text{s/m}^2} = 693$$

and the flow is laminar. The friction factor is given by Equation 8.19,

$$f = 64/Re_D$$

and the pressure drop by Equation 8.22a,

$$\Delta p = f \frac{\rho u_m^2}{2D} (x_2 - x_1) = 32 \frac{\rho u_m^2}{D Re_D} L$$

where  $u_m$  can be found from  $\dot{m} = \rho u_m A_c$  :

$$u_m = \frac{\dot{m}}{\rho A_c} = \frac{\dot{m}}{\rho \pi D^2/4} = \frac{4 \times 500 \text{ kg/s}}{900 \text{ kg/m}^3 \times \pi \times (1.2 \text{ m})^2} = 0.491 \text{ m/s}$$

Thus

$$p_{in} - p_{out} = \Delta p = \frac{32 \times 900 \text{ kg/m}^3 \times (0.491 \text{ m/s})^2 \times 100,000 \text{ m}}{1.2 \text{ m} \times 693} = 8.4 \times 10^5 \text{ Pa}$$

$$\Delta p = 0.84 \text{ MPa} \quad <$$

The flow work is then found from its definition (see discussion leading to Equation 1.11d),

$$\begin{aligned} \dot{W}_{flow} &= \frac{\dot{m}}{\rho} (p_{in} - p_{out}) = 500 \text{ kg/s} \times 0.84 \text{ MPa} / 900 \text{ kg/m}^3 \\ &= 0.46 \text{ MW} \quad < \end{aligned}$$

Finally, with reference to Equation 1.12d, the portion of the temperature rise due to flow work is given by

$$\begin{aligned} \dot{m} c_p \Delta T_{flow} &= \frac{\dot{m}}{\rho} (p_{in} - p_{out}) = \dot{W}_{flow} \\ \Delta T_{flow} &= \dot{W}_{flow} / \dot{m} c_p = 0.46 \text{ MW} / (500 \text{ kg/s} \times 2000 \text{ J/kg}\cdot\text{K}) \\ &= 0.46^\circ\text{C} \quad < \end{aligned}$$

**COMMENTS:** Despite the long length of pipeline and high viscosity of the oil, which results in a large pressure drop, the temperature rise due to the flow work is quite small.

## PROBLEM 8.10

**KNOWN:** Thermal energy equation describing laminar, fully developed flow in a circular pipe with viscous dissipation.

**FIND:** (a) Left hand side of equation integrated over the pipe volume, (b) viscous dissipation term integrated over the same volume, (c) temperature rise caused by viscous dissipation.

**SCHEMATIC:**

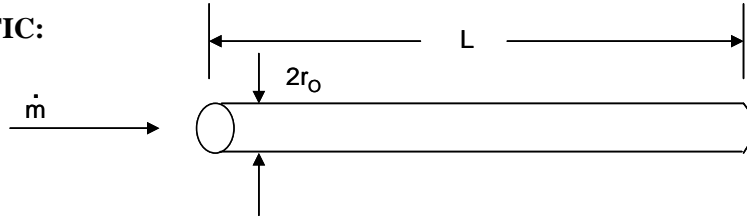

**ASSUMPTIONS:** (1) Steady-state, (2) Laminar, (3) Fully-developed.

**ANALYSIS:** (a) The thermal energy equation is given as

$$\rho c_p u \frac{\partial T}{\partial x} = \frac{k}{r} \frac{\partial}{\partial r} \left( r \frac{\partial T}{\partial r} \right) + \mu \left( \frac{du}{dr} \right)^2$$

where  $u$  is given by Equation 8.15,

$$u = 2 u_m \left[ 1 - (r/r_0)^2 \right]$$

Integrating the advection term on the left-hand side over a section of the pipe of length  $L$ , we have

$$\begin{aligned} \text{Adv.} &= \int_0^L \int_{A_c} \rho c_p u \frac{\partial T}{\partial x} dA_c dx \\ &= \int_0^L \frac{d}{dx} \left[ \int_{A_c} \rho c_p u T dA_c \right] dx \end{aligned}$$

From Equation 8.25, the term in square brackets is  $\dot{m} c_p T_m$ , thus

$$\text{Adv.} = \int_0^L \dot{m} c_p \frac{dT_m}{dx} dx = \dot{m} c_p (T_{m,o} - T_{m,i}) \quad <$$

which coincides with the right-hand side of Equation 8.34.

(b) Integrating the viscous dissipation term, we have

$$\begin{aligned} \text{Visc. Diss.} &= \int_0^L \int_{A_c} \mu \left( \frac{du}{dr} \right)^2 dA_c dx \\ &= \int_0^L 2 \pi \mu \int_0^{r_0} \left( \frac{du}{dr} \right)^2 r dr dx \\ &= 2 \pi \mu L \int_0^{r_0} 16 u_m^2 \frac{r^2}{r_0^4} r dr \\ &= 32 \pi \mu L u_m^2 \frac{r^2}{4 r_0^4} \Big|_0^{r_0} = 8 \pi \mu L u_m^2 \quad < \end{aligned}$$

Continued...

### PROBLEM 8.10 (Cont.)

(c) Using the values from Problem 8.9,

$$\dot{m} c_p \Delta T_{v.d.} = 8 \pi \mu L u_m^2$$

$$\Delta T_{v.d.} = 8 \pi \mu L u_m^2 / \dot{m} c_p$$

where  $u_m = \dot{m} / \rho A_c$ . Thus

$$\Delta T_{v.d.} = \frac{8 \pi \mu L \dot{m}}{\rho^2 c_p A_c^2}$$

$$= \frac{8\pi \times 0.765 \text{ N}\cdot\text{s/m}^2 \times 100,000 \text{ m} \times 500 \text{ kg/s}}{\left[ (900 \text{ kg/m}^3)^2 \times 2000 \text{ J/kg}\cdot\text{K} \times (\pi \times (1.2 \text{ m})^2/4)^2 \right]}$$

$$= 0.46^\circ\text{C}$$

<

**COMMENTS:** (1) Even in the case of a long pipe with a highly viscous fluid, the temperature rise due to viscous dissipation is quite small. (2) The temperature rise due to viscous dissipation is identical to the temperature rise due to flow work in Problem 8.9. This is no coincidence. In fully-developed pipe flow, there is a balance between the viscous forces (friction) and the pressure drop needed to overcome them. As a result, viscous dissipation exactly equals the work done by the pressure forces (flow work). Conservation of energy can be expressed in a form that includes flow work (for example, Equation 1.12d) or in a form that includes viscous dissipation (for example, Equation 6.29), and in the case of fully-developed pipe flow they are equal.

## PROBLEM 8.11

**KNOWN:** Mass flow rate in a circular tube, tube length and diameter, thermal conditions.

**FIND:** (a) Expression for  $(T_s(x=L) - T_{m,i})/q$  for constant heat flux conditions, (b)  $(T_s - T_{m,i})/q$  for constant surface temperature conditions.

**SCHEMATIC:**

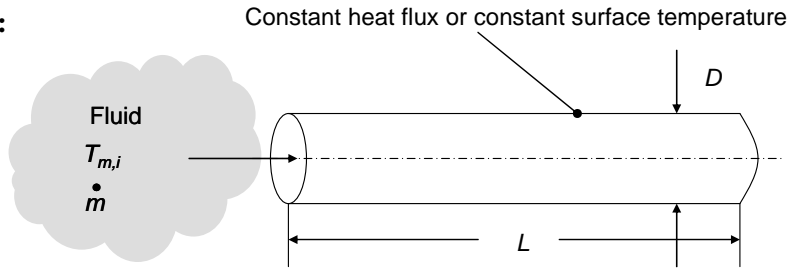

**ASSUMPTIONS:** (1) Constant properties.

**ANALYSIS** (a) From Newton's law of cooling,

$$T_s(x=L) - T_m(x=L) = q'' / h \quad (1)$$

and from an energy balance on the entire tube,

$$T_m(x=L) = T_{m,i} + q / \dot{m}c_p \quad (2)$$

Combining Eqs. (1) and (2) and noting that  $q = q''\pi DL$  yields

$$\frac{T_s(x=L) - T_{m,i}}{q} = \frac{1}{\pi DLh} + \frac{1}{\dot{m}c_p}$$

Substituting the expression for the local Nusselt number,  $Nu_D = hD/k$  gives

$$\frac{T_s(x=L) - T_{m,i}}{q} = \frac{1}{Nu_D \pi Lk} + \frac{1}{\dot{m}c_p} \quad <$$

(b) From Eq. (8.41b)

$$\frac{T_s - T_m(x=L)}{T_s - T_{m,i}} = \exp\left(-\frac{\pi D \bar{h} L}{\dot{m}c_p}\right) \quad (3)$$

Combining Eqs. (2) and (3) yields

$$1 - \frac{q / \dot{m}c_p}{(T_s - T_{m,i})} = \exp\left(-\frac{\pi D \bar{h} L}{\dot{m}c_p}\right)$$

Continued...

### PROBLEM 8.11 (Cont.)

which may be rearranged to yield

$$\frac{q}{(T_s - T_{m,i})} = \dot{m}c_p \left[ 1 - \exp\left(-\frac{\pi D \bar{h} L}{\dot{m}c_p}\right) \right]$$

or

$$\frac{(T_s - T_{m,i})}{q} = \frac{1}{\dot{m}c_p \left[ 1 - \exp\left(-\frac{\pi \overline{Nu}_D k L}{\dot{m}c_p}\right) \right]} \quad <$$

**COMMENTS:** (1) The ratio on the LHS is a *figure of merit* that, in many applications, is sought to be minimized. (2) The two terms on the RHS of the final expression for the constant heat flux case may be thought of as thermal resistances. The first term on the RHS is a thermal resistance associated with heat transfer between the fluid and the tube wall at the tube exit, and the second term is associated with the increase in temperature between the tube inlet and the tube exit. (3) As the argument of the exponential term increases in magnitude for the constant surface temperature expression, the mean outlet temperature approaches the surface temperature value (see Eq. 3), and the figure of merit expression reduces to Eq. (2).

## PROBLEM 8.12

**KNOWN:** Internal flow with prescribed wall heat flux as a function of distance.

**FIND:** (a) Beginning with a properly defined differential control volume, the temperature distribution,  $T_m(x)$ , (b) Outlet temperature,  $T_{m,o}$ , (c) Sketch  $T_m(x)$ , and  $T_s(x)$  for fully developed *and* developing flow conditions, and (d) Value of uniform wall flux  $q_s''$  (instead of  $q_s' = ax$ ) providing same outlet temperature as found in part (a); sketch  $T_m(x)$  and  $T_s(x)$  for this heating condition.

**SCHEMATIC:**

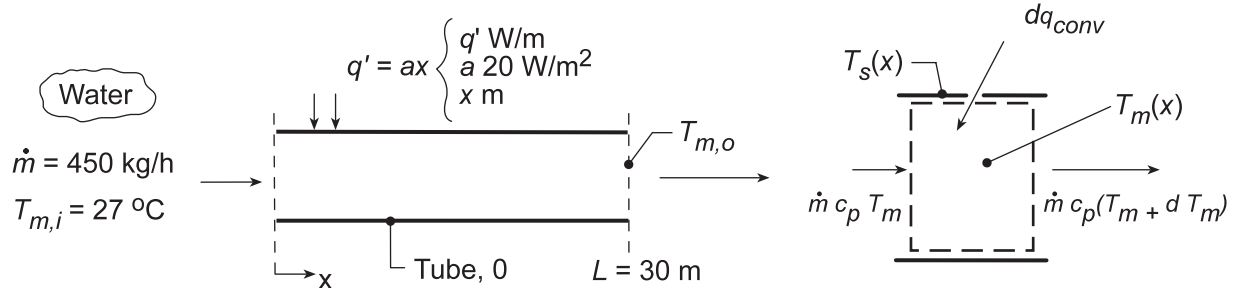

**ASSUMPTIONS:** (1) Steady-state conditions, (2) Constant properties, (3) Incompressible liquid with negligible viscous dissipation.

**PROPERTIES:** Table A.6, Water (300 K):  $c_p = 4.179 \text{ kJ/kg}\cdot\text{K}$ .

**ANALYSIS:** (a) Applying energy conservation to the control volume above,

$$dq_{\text{conv}} = \dot{m} c_p dT_m \quad (1)$$

where  $T_m(x)$  is the mean temperature at any cross-section and  $dq_{\text{conv}} = q' \cdot dx$ . Hence,

$$ax = \dot{m} c_p \frac{dT_m}{dx} \quad (2)$$

Separating and integrating with proper limits gives

$$a \int_{x=0}^x x dx = \dot{m} c_p \int_{T_{m,i}}^{T_m(x)} dT_m \quad T_m(x) = T_{m,i} + \frac{ax^2}{2\dot{m}c_p} \quad (3,4) <$$

(b) To find the outlet temperature, let  $x = L$ , then

$$T_m(L) = T_{m,o} = T_{m,i} + aL^2/2\dot{m}c_p \quad (5)$$

Solving for  $T_{m,o}$ , we find

$$T_{m,o} = 27^\circ\text{C} + \frac{20 \text{ W/m}^2 (30 \text{ m}^2)}{2(450 \text{ kg/h}/(3600 \text{ s/h})) \times 4179 \text{ J/kg}\cdot\text{K}} = 27^\circ\text{C} + 17.2^\circ\text{C} = 44.2^\circ\text{C} \quad <$$

(c) For *linear wall heating*,  $q_s' = ax$ , the fluid temperature distribution along the length of the tube is quadratic as prescribed by Eq. (4). From the convection rate equation,

$$q_s' = h(x) \cdot \pi D (T_s(x) - T_m(x)) \quad (6)$$

For fully developed flow conditions,  $h(x) = h$  is a constant; hence,  $T_s(x) - T_m(x)$  increases linearly with  $x$ . For developing conditions,  $h(x)$  will decrease with increasing distance along the tube eventually achieving the fully developed value.

Continued...



**PROBLEM 8.12 (Cont.)**

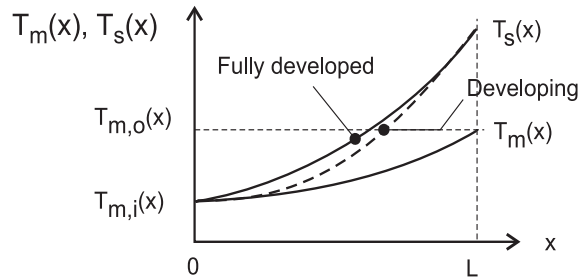

(d) For *uniform wall heat flux heating*, the overall energy balance on the tube yields

$$q = q_s'' \pi D L = \dot{m} c_p (T_{m,o} - T_{m,i})$$

Requiring that  $T_{m,o} = 44.2^\circ\text{C}$  from part (a), find

$$q_s'' = \frac{(450/3600) \text{ kg/s} \times 4179 \text{ J/kg} \cdot \text{K} (44.2 - 27) \text{ K}}{\pi D \times 30 \text{ m}} = 95.3/D \text{ W/m}^2$$

<

where  $D$  is the diameter (m) of the tube which, when specified, would permit determining the required heat flux,  $q_s''$ . For uniform heating, Section 8.3.2, we know that  $T_m(x)$  will be linear with distance.  $T_s(x)$  will also be linear for fully developed conditions and appear as shown below when the flow is developing.

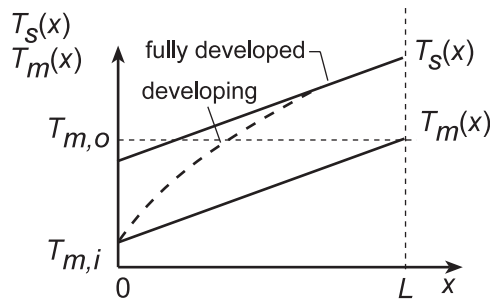

**COMMENTS:** (1) Note that  $c_p$  should be evaluated at  $T_m = (27 + 44)^\circ\text{C}/2 = 309 \text{ K}$ .

(2) Why did we show  $T_s(0) = T_m(0)$  for both types of history when the flow was developing?

(3) Why must  $T_m(x)$  be linear with distance in the case of uniform wall flux heating?

### PROBLEM 8.13

**KNOWN:** Internal flow with constant surface heat flux,  $q_s''$ .

**FIND:** (a) Qualitative temperature distributions,  $T(x)$ , under developing and fully-developed flow, (b) Exit mean temperature for both situations.

**SCHEMATIC:**

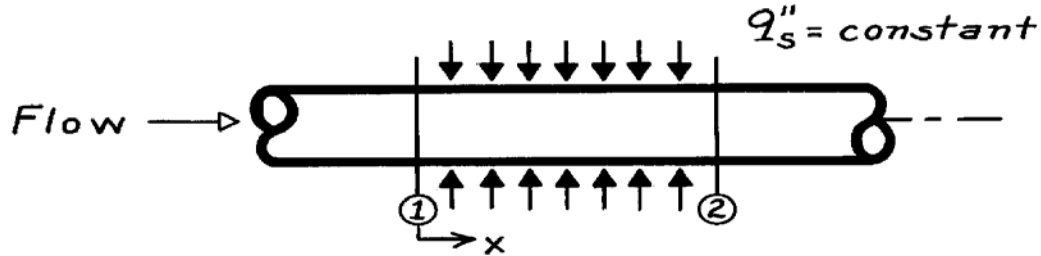

**ASSUMPTIONS:** (a) Steady-state conditions, (b) Constant properties, (c) Incompressible flow with negligible viscous dissipation.

**ANALYSIS:** Based upon the analysis leading to Eq. 8.39, note for the case of constant surface heat flux conditions,

$$\frac{dT_m}{dx} = \text{constant.}$$

Hence, regardless of whether the hydrodynamic or thermal boundary layer is fully developed, it follows that

$T_m(x)$  is linear and

$T_{m,2}$  will be the same for all flow conditions. <

The surface heat flux can also be written, using Eq. 8.27, as

$$q_s'' = h[T_s(x) - T_m(x)].$$

Under fully-developed flow and thermal conditions,  $h = h_{fd}$  is a constant. When flow is developing  $h > h_{fd}$ . Hence, the temperature distributions appear as below.

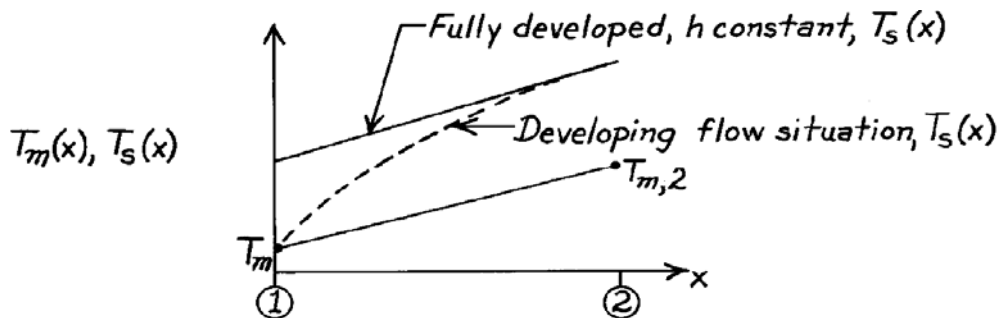

<

### PROBLEM 8.14

**KNOWN:** Geometry and coolant flow conditions associated with a nuclear fuel rod. Axial variation of heat generation within the rod.

**FIND:** (a) Axial variation of local heat flux and total heat transfer rate, (b) Axial variation of mean coolant temperature, (c) Axial variation of rod surface temperature and location of maximum temperature.

**SCHEMATIC:**

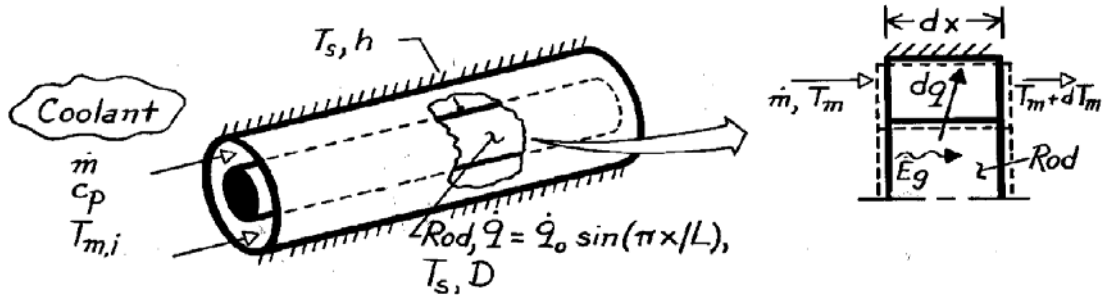

**ASSUMPTIONS:** (1) Steady-state conditions, (2) Constant fluid properties, (3) Uniform surface convection coefficient, (4) Negligible axial conduction in rod and fluid, (5) Incompressible liquid with negligible viscous dissipation, (6) Outer surface is adiabatic.

**ANALYSIS:** (a) Performing an energy balance for a control volume about the rod,

$$\dot{E}_{in} - \dot{E}_{out} + \dot{E}_g = 0 \quad -dq + \dot{E}_g = 0$$

or

$$-q''(\pi D dx) + \dot{q}_o \sin(\pi x/L) \left(\pi D^2/4\right) dx = 0 \quad q'' = \dot{q}_o (D/4) \sin(\pi x/L). \quad <$$

The total heat transfer rate is then

$$q = \int_0^L q'' \pi D dx = \left(\pi D^2/4\right) \dot{q}_o \int_0^L \sin(\pi x/L) dx$$

$$q = \frac{\pi D^2}{4} \dot{q}_o \left( -\frac{L}{\pi} \cos \frac{\pi x}{L} \right) \Big|_0^L = \frac{D^2 \dot{q}_o L}{4} (1+1)$$

$$q = \frac{D^2 L}{2} \dot{q}_o. \quad (1) <$$

(b) Performing an energy balance for a control volume about the coolant,

$$\dot{m} c_p T_m + dq = \dot{m} c_p (T_m + dT_m) = 0.$$

Hence

$$\dot{m} c_p dT_m = dq = (\pi D dx) q''$$

$$\frac{dT_m}{dx} = \frac{\pi D}{\dot{m} c_p} \frac{\dot{q}_o D}{4} \sin\left(\frac{\pi x}{L}\right).$$

Continued ...

**PROBLEM 8.14 (Cont.)**

Integrating,

$$T_m(x) - T_{m,i} = \frac{\pi D^2}{4} \frac{\dot{q}_o}{\dot{m} c_p} \int_0^x \sin \frac{\pi x}{L} dx$$

$$T_m(x) = T_{m,i} + \frac{L D^2}{4} \frac{\dot{q}_o}{\dot{m} c_p} \left[ 1 - \cos \frac{\pi x}{L} \right] \quad (2) <$$

(c) From Newton's law of cooling,

$$q'' = h(T_s - T_m).$$

Hence

$$T_s = \frac{q''}{h} + T_m$$

$$T_s = \frac{\dot{q}_o D}{4h} \sin \frac{\pi x}{L} + T_{m,i} + \frac{L D^2}{4} \frac{\dot{q}_o}{\dot{m} c_p} \left[ 1 - \cos \frac{\pi x}{L} \right]. \quad <$$

To determine the location of the maximum surface temperature, evaluate

$$\frac{dT_s}{dx} = 0 = \frac{\dot{q}_o D \pi}{4hL} \cos \frac{\pi x}{L} + \frac{L D^2}{4} \frac{\dot{q}_o}{\dot{m} c_p} \frac{\pi}{L} \sin \frac{\pi x}{L}$$

or

$$\frac{1}{hL} \cos \frac{\pi x}{L} + \frac{D}{\dot{m} c_p} \sin \frac{\pi x}{L} = 0.$$

Hence

$$\tan \frac{\pi x}{L} = -\frac{\dot{m} c_p}{D h L}$$

$$x = \frac{L}{\pi} \tan^{-1} \left( -\frac{\dot{m} c_p}{D h L} \right) = x_{\max}. \quad <$$

**COMMENTS:** Note from Eq. (2) that

$$T_{m,o} = T_m(L) = T_{m,i} + \frac{L D^2 \dot{q}_o}{2 \dot{m} c_p}$$

which is equivalent to the result obtained by combining Eq. (1) and Eq. 8.34.

## PROBLEM 8.15

**KNOWN:** Laminar boundary layer development in a tube entrance.

**FIND:** (a) Expression for  $Nu_D$  in terms of  $Gz_D^{-1}$  and  $Pr$ . Plot of  $Nu_D$  versus  $Gz_D^{-1}$  for  $Pr = 0.7$ . (b) Expression for  $\overline{Nu}_D$  in terms of  $Gz_D^{-1}$  and  $Pr$ . Comparison to combined entrance length correlation in the limit of small  $x$ .

**SCHEMATIC:**

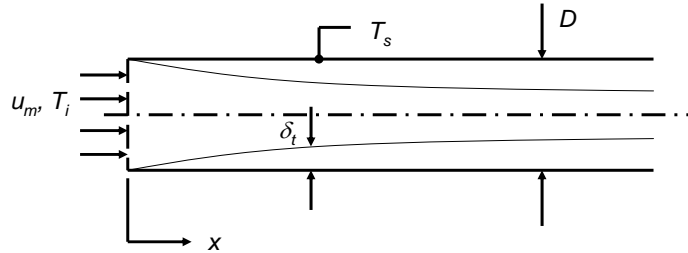

**ASSUMPTIONS:** (1) Constant properties. (2) Laminar conditions.

**ANALYSIS:** (a) From Equation 7.23, the Nusselt number based upon the streamwise coordinate  $x$  is

$$Nu_x = \frac{hx}{k} = 0.332 Re_x^{1/2} Pr^{1/3} \quad (1)$$

Multiplying both sides of Equation 1 by  $D/x$  and substituting  $Re_x = Re_D x/D$  yields

$$Nu_D = \frac{hD}{k} = 0.332 \left[ Re_x \left( \frac{x}{D} \right) \right]^{1/2} \left[ \frac{D}{x} \right] Pr^{1/3} = 0.332 \left[ Re_x \left( \frac{D}{x} \right) \right]^{1/2} Pr^{1/3} \quad (2)$$

Substituting  $Gz_D^{-1} = (x/D)/(Re_D Pr)$  into Equation 2 and noting that  $Pr^{1/3} = Pr^{1/2} \cdot Pr^{-1/6}$  yields

$$Nu_D = 0.332 [Gz_D^{-1}]^{-1/2} Pr^{-1/6} \quad <$$

The expression for the local Nusselt number,  $Nu_D$  with  $Pr = 0.7$  is plotted below.

Continued...

**PROBLEM 8.15 (Cont.)**

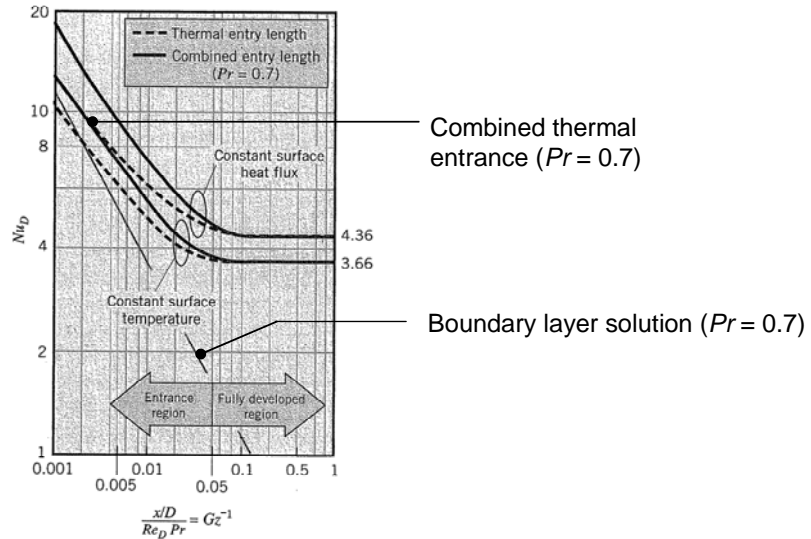

(b) Equation 7.30 gives the following for the average Nusselt number:

$$\overline{Nu}_x = \frac{\bar{h}_x x}{k} = 0.664 Re_x^{1/2} Pr^{1/3}$$

Following the same steps as in part (a), this can be rewritten as

$$\overline{Nu}_D = 0.664 [Gz_D^{-1}]^{-1/2} Pr^{-1/6} \quad (3)$$

The average Nusselt number for the combined entrance length is given as

$$\overline{Nu}_D = \frac{\frac{3.66}{\tanh\left[2.264 Gz_D^{-1/3} + 1.7 Gz_D^{-2/3}\right]} + 0.0499 Gz_D \tanh\left(Gz_D^{-1}\right)}{\tanh\left(2.432 Pr^{1/6} Gz_D^{-1/6}\right)}$$

In the limit of small  $x$ ,  $Gz_D^{-1}$  is also small. Furthermore,  $Gz_D^{-2/3} \ll Gz_D^{-1/3}$ . Noting that  $\tanh(\varepsilon) \rightarrow \varepsilon$  as  $\varepsilon \rightarrow 0$ , we find

$$\begin{aligned} \overline{Nu}_D &= \frac{\frac{3.66}{\tanh\left[2.264 Gz_D^{-1/3} + 1.7 Gz_D^{-2/3}\right]} + 0.0499 Gz_D \tanh\left(Gz_D^{-1}\right)}{\tanh\left(2.432 Pr^{1/6} Gz_D^{-1/6}\right)} \\ &\rightarrow \frac{\frac{3.66}{2.264 Gz_D^{-1/3}} + 0.0499 Gz_D Gz_D^{-1}}{2.432 Pr^{1/6} Gz_D^{-1/6}} \rightarrow \frac{3.66}{2.264 \times 2.432 Gz_D^{-1/6} Gz_D^{-1/3} Pr^{1/6}} = 0.665 [Gz_D^{-1}]^{-1/2} Pr^{-1/6} \end{aligned}$$

This is in excellent agreement with Eq. (3).

Continued...

### PROBLEM 8.15 (Cont.)

**COMMENT:** The combined thermal entrance length solution and the boundary layer solution based upon the results of Chapter 7 exhibit asymptotic behavior at small inverse Graetz numbers. Small values of  $Gz_D^{-1}$  correspond to the locations where the boundary layer is very thin.

### PROBLEM 8.16

**KNOWN:** Axial variation of surface heat flux for flow through a tube.

**FIND:** Axial variation of fluid and surface temperatures.

**SCHEMATIC:**

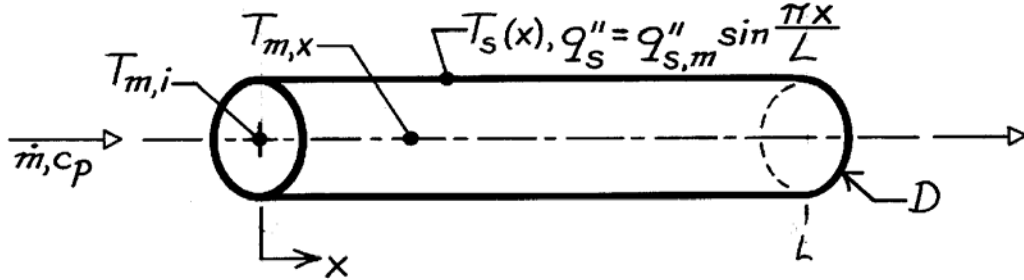

**ASSUMPTIONS:** (1) Convection coefficient is independent of \$x\$, (2) Applicability of Eq. 8.34.

**ANALYSIS:** Since Equation 8.37 is applicable,

$$\frac{dT_m}{dx} = \frac{q_s'' P}{\dot{m} c_p} = \frac{(\pi D) q_{s,m}'' \sin(\pi x/L)}{\dot{m} c_p}$$

Separating variables and integrating from \$x = 0\$

$$\int_{T_{m,i}}^{T_{m,o}} dT_m = \frac{\pi D q_{s,m}''}{\dot{m} c_p} \int_0^x \sin \frac{\pi x}{L} dx$$

$$T_m(x) - T_{m,i} = -\frac{LD q_{s,m}''}{\dot{m} c_p} \cos \frac{\pi x}{L} \Big|_0^x$$

$$T_m(x) = T_{m,i} + \frac{LD q_{s,m}''}{\dot{m} c_p} (1 - \cos \pi x/L). \quad <$$

From Newton's law of cooling, Eq. 8.27,

$$T_s(x) = (q_s''/h) + T_m(x)$$

$$T_s(x) = \frac{q_{s,m}''}{h} \sin \frac{\pi x}{L} + T_{m,i} + \frac{LD q_{s,m}''}{\dot{m} c_p} (1 - \cos \pi x/L). \quad <$$

**COMMENTS:** For the prescribed surface condition, the flow is not fully developed. Hence, the assumption of constant \$h\$ should be viewed as a first approximation.



### PROBLEM 8.17

**KNOWN:** Surface heat flux for air flow through a rectangular channel.

**FIND:** (a) Differential equation describing variation in air mean temperature, (b) Air outlet temperature for prescribed conditions.

**SCHEMATIC:**

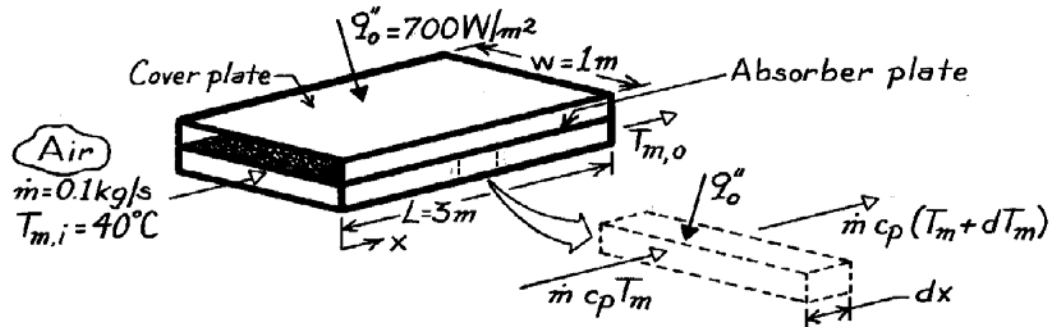

**ASSUMPTIONS:** (1) Ideal gas with negligible viscous dissipation and pressure variation, (2) No heat loss through bottom of channel, (3) Uniform heat flux at top of channel.

**PROPERTIES:** Table A-4, Air ( $T \approx 50^\circ\text{C}$ , 1 atm):  $c_p = 1008 \text{ J/kg}\cdot\text{K}$ .

**ANALYSIS:** (a) For the differential control volume about the air,

$$\dot{E}_{\text{in}} = \dot{E}_{\text{out}}$$

$$\dot{m} c_p T_m + q_o'' (w \cdot dx) = \dot{m} c_p (T_m + dT_m)$$

$$\frac{dT_m}{dx} = \frac{q_o'' \cdot w}{\dot{m} c_p}$$

Separating and integrating between the limits of  $x = 0$  and  $x$ , find

$$T_m(x) = T_{m,i} + \frac{q_o'' (w \cdot x)}{\dot{m} c_p}$$

$$T_{m,o} = T_{m,i} + \frac{q_o'' (w \cdot L)}{\dot{m} c_p} \quad <$$

(b) Substituting numerical values, the air outlet temperature is

$$T_{m,o} = 40^\circ\text{C} + \frac{(700 \text{ W/m}^2) (1 \times 3) \text{ m}^2}{0.1 \text{ kg/s} (1008 \text{ J/kg}\cdot\text{K})}$$

$$T_{m,o} = 60.8^\circ\text{C} \quad <$$

**COMMENTS:** Due to increasing heat loss with increasing  $T_m$ , the net flux  $q_o''$  will actually decrease slightly with increasing  $x$ .

## PROBLEM 8.18

**KNOWN:** Air inlet conditions and heat transfer coefficient for a circular tube of prescribed geometry. Surface heat flux.

**FIND:** (a) Tube heat transfer rate,  $q$ , air outlet temperature,  $T_{m,o}$ , and surface inlet and outlet temperatures,  $T_{s,i}$  and  $T_{s,o}$ , for a uniform surface heat flux,  $q''_s$ . Air mean and surface temperature distributions. (b) Values of  $q$ ,  $T_{m,o}$ ,  $T_{s,i}$  and  $T_{s,o}$  for a linearly varying surface heat flux  $q''_s = 500x$  (m). Air mean and surface temperature distributions, (c) For each type of heating process (a & b), compute and plot the mean fluid and surface temperatures,  $T_m(x)$  and  $T_s(x)$ , respectively, as a function of distance; What is effect of four-fold increase in convection coefficient, and (d) For each type of heating process, heat fluxes required to achieve an outlet temperature of  $T_{m,o} = 125^\circ\text{C}$ ; Plot temperatures.

**SCHEMATIC:**

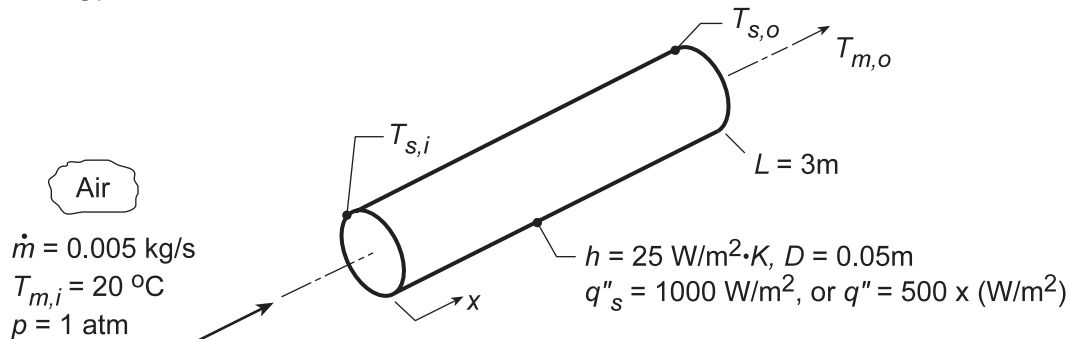

**ASSUMPTIONS:** (1) Fully developed conditions in the tube, (2) Applicability of Eq. 8.34, (3) Heat transfer coefficient is the same for both heating conditions.

**PROPERTIES:** Table A.4, Air (for an assumed value of  $T_{m,o} = 100^\circ\text{C}$ ,  $\bar{T}_m = (T_{m,i} + T_{m,o})/2 = 60^\circ\text{C} = 333 \text{ K}$ ):  $c_p = 1.008 \text{ kJ/kg}\cdot\text{K}$ .

**ANALYSIS:** (a) With constant heat flux, from Eq. 8.38,

$$q = q''_s (\pi DL) = 1000 \text{ W/m}^2 (\pi \times 0.05 \text{ m} \times 3 \text{ m}) = 471 \text{ W} . \quad (1)$$

From the overall energy balance, Eq. 8.34,

$$T_{m,o} = T_{m,i} + \frac{q}{\dot{m}c_p} = 20^\circ\text{C} + \frac{471 \text{ W}}{0.005 \text{ kg/s} \times 1008 \text{ J/kg}\cdot\text{K}} = 113.5^\circ\text{C} \quad (2) <$$

From the convection rate equation, it follows that

$$T_{s,i} = T_{m,i} + \frac{q''_s}{h} = 20^\circ\text{C} + \frac{1000 \text{ W/m}^2}{25 \text{ W/m}^2\cdot\text{K}} = 60^\circ\text{C} \quad (3) <$$

$$T_{s,o} = T_{m,o} + q''_s/h = 113.5^\circ\text{C} + 40^\circ\text{C} = 153.5^\circ\text{C} \quad <$$

From Eq. 8.39,  $(dT_m/dx)$  is a constant, as is  $(dT_s/dx)$  for constant  $h$  from Eq. 8.30. In the more realistic case for which  $h$  decreases with  $x$  in the entry region,  $(dT_m/dx)$  is still constant but  $(dT_s/dx)$  decreases with increasing  $x$ . See the plot below.

(b) From Eq. 8.37,

$$\frac{dT_m}{dx} = \frac{500x (\pi D)}{\dot{m}c_p} = \frac{500x \text{ W/m}^2 (\pi \times 0.05 \text{ m})}{0.005 \text{ kg/s} \times 1008 \text{ J/kg}\cdot\text{K}} = 15.6x \text{ K/m} . \quad (4)$$

Continued...

### PROBLEM 8.18 (Cont.)

Integrating from  $x = 0$  to  $L$  it follows that

$$T_{m,o} = T_{m,i} + 15.6 \int_0^3 x dx = 20^\circ\text{C} + 15.6 \frac{x^2}{2} \Big|_0^3 = 20^\circ\text{C} + 70.2^\circ\text{C} = 90.2^\circ\text{C}. \quad (5) <$$

The heat rate is

$$q = \int q_s'' dA_s = 500(\pi \times 0.05 \text{ m}) \int_0^3 x dx = 78.5 \frac{x^2}{2} \Big|_0^3 = 353 \text{ W} <$$

From Eq. 8.27 it then follows that

$$T_s = T_m + q_s''/h = T_{m,i} + 15.6 \frac{x^2}{2} + \frac{500}{25} x = 20^\circ\text{C} + 7.8x^2 + 20x \quad (6)$$

Hence, at the inlet ( $x = 0$ ) and outlet ( $x = L$ ),

$$T_{s,i} = T_{m,i} = 20^\circ\text{C} \quad \text{and} \quad T_{s,o} = 150.2^\circ\text{C} <$$

Note that  $(dT_s/dx)$  and  $(dT_m/dx)$  both increase linearly with  $x$ , but  $(dT_s/dx) > (dT_m/dx)$ .

(c) The foregoing relations can be used to determine  $T_m(x)$  and  $T_s(x)$  for the two heating conditions:

*Uniform surface flux,  $q_s''$ ; Eqs. (1-3),*

$$T_m(x) = T_{m,i} + q_s'' \pi D x / \dot{m} c_p \quad T_s(x) = T_m(x) + q_s''/h \quad (7,8)$$

*Linear surface heat flux,  $q_s'' = a_o x$ ,  $a_o = 500 \text{ W/m}^3$ ; Eqs. (4-6),*

$$T_m(x) = T_{m,i} + \left( a_o \pi D / 2 \dot{m} c_p \right) x^2 \quad T_s(x) = T_m(x) + a_o x / h \quad (9, 10)$$

Using Eqs. (7-10) in IHT, the mean fluid and surface temperatures as a function of distance are evaluated and plotted below. The calculations were repeated with the coefficient increased four-fold,  $h = 4 \times 25 = 100 \text{ W/m}^2 \cdot \text{K}$ . As expected, the fluid temperature remained unchanged, but the surface temperatures decreased since the thermal resistance between the surface and fluid decreased.

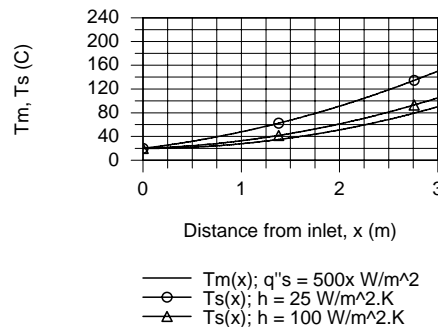
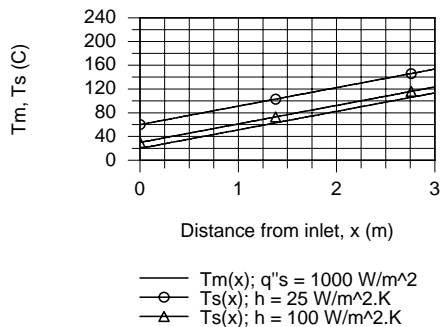

(d) The foregoing set of equations, Eqs. (7-10), in the IHT model can be used to determine the required heat fluxes for the two heating conditions to achieve  $T_{m,o} = 125^\circ\text{C}$ . The results with  $h = 25 \text{ W/m}^2 \cdot \text{K}$  are:

$$\text{Uniform flux: } q_s'' = 1123 \text{ W/m}^2 \quad \text{Linear flux: } q_s'' = 748.7x \text{ W/m}^2 <$$

Continued...

### PROBLEM 8.18 (Cont.)

The temperature distributions resulting from these heat fluxes are plotted below. The heat rate for both heating processes is 529 W.

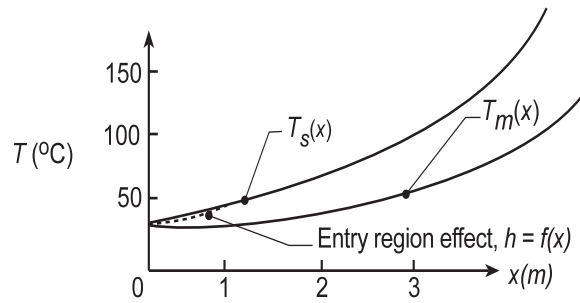
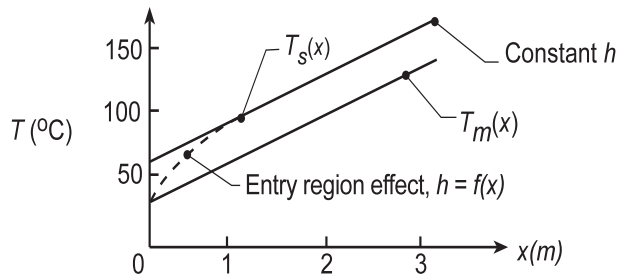
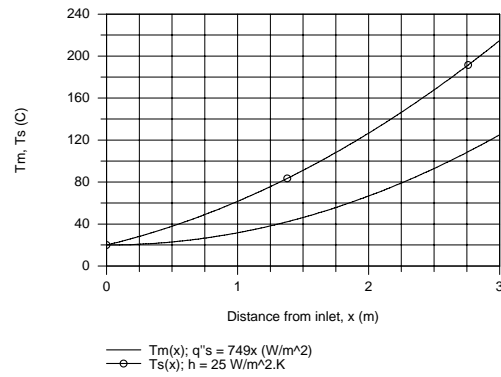
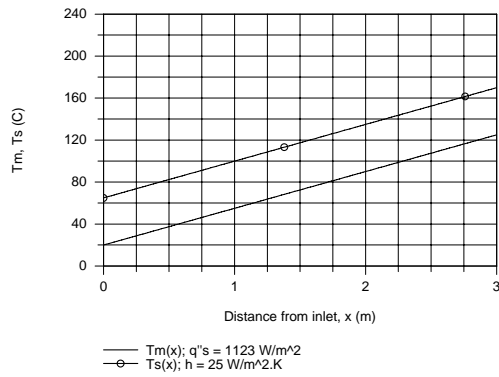

**COMMENTS:** Note that the assumed value for  $T_{m,o}$  (100°C) in determining the specific heat of the air was reasonable.

## PROBLEM 8.19

**KNOWN:** Tube length, diameter and surface temperature. Mass flow rate and inlet temperature of fluid.

**FIND:** (a) Heat transfer rate if the fluid is water. (b) Heat transfer rate for the nanofluid of Example 2.2.

**SCHEMATIC:**

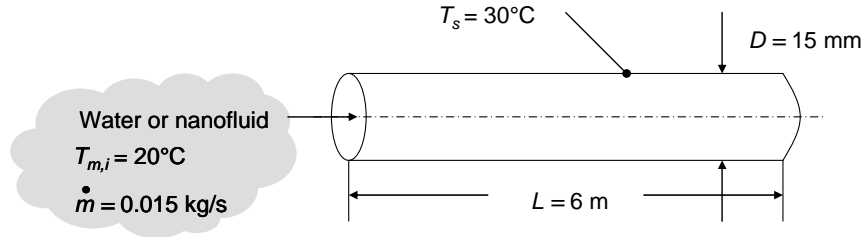

**ASSUMPTIONS:** (1) Constant properties, (2) Negligible viscous dissipation.

**PROPERTIES:** Table A.4, water (300 K):  $\mu_{\text{bf}} = 855 \times 10^{-6}\text{ m}^2/\text{s}$ ,  $k_{\text{bf}} = 0.613\text{ W/m}\cdot\text{K}$ ,  $c_{p,\text{bf}} = 4179\text{ J/kg}\cdot\text{K}$ ,  $Pr_{\text{bf}} = 5.83$ . Example 2.2, nanofluid (300 K):  $\rho_{\text{nf}} = 1146\text{ kg/m}^3$ ,  $\mu_{\text{nf}} = 962 \times 10^{-6}\text{ m}^2/\text{s}$ ,  $\nu_{\text{nf}} = \mu_{\text{nf}}/\rho_{\text{nf}} = 839 \times 10^{-9}\text{ m}^2/\text{s}$ ,  $k_{\text{nf}} = 0.705\text{ W/m}\cdot\text{K}$ ,  $c_{p,\text{nf}} = 3587\text{ J/kg}\cdot\text{K}$ ,  $\alpha_{\text{nf}} = 171 \times 10^{-9}\text{ m}^2/\text{s}$ ,  $Pr_{\text{nf}} = \nu_{\text{nf}}/\alpha_{\text{nf}} = 4.91$ .

**ANALYSIS:** (a) The Reynolds number is

$$Re_D = 4\dot{m} / \pi D \mu_{\text{bf}} = 4 \times 0.015\text{ kg/s} / \left[ \pi \times 0.015\text{ m} \times 855 \times 10^{-6}\text{ m}^2/\text{s} \right] = 1489$$

Therefore the flow is laminar. The hydrodynamic and thermal entry lengths are

$$x_{fd,h} = 0.05DRe_D = 0.05 \times 0.015\text{ m} \times 1489 = 1.12\text{ m}$$

$$x_{fd,t} = 0.05DRe_DPr_{\text{bf}} = 0.05 \times 0.015\text{ m} \times 1489 \times 5.83 = 6.51\text{ m}$$

Since the tube length is  $L = 6\text{ m}$ , the temperature is still developing. The hydrodynamic entry length is less than the tube length, but perhaps not sufficiently shorter to consider the velocity to be fully developed through the entire tube. With  $Pr_{\text{bf}} > 5$ , the Hausen correlation, Equation 8.57, could be used as an approximation. However the nanofluid Prandtl number is less than 5. To compare the two fluids on an equal basis, we will use the combined entry correlation, Equation 8.58, for both. With  $G_{z,D} = (D/L)Re_DPr_{\text{bf}} = (0.015\text{ m}/6\text{ m}) \times 1489 \times 5.83 = 21.7$ , Equation 8.58 is

$$\overline{Nu}_D = \frac{\frac{3.66}{\tanh\left[2.264 \times 21.7^{-1/3} + 1.7 \times 21.7^{-2/3}\right]} + 0.0499 \times 21.7 \times \tanh\left(21.7^{-1}\right)}{\tanh\left(2.432 \times 5.83^{1/6} \times 21.7^{-1/6}\right)} = 4.98$$

Therefore  $\bar{h} = \overline{Nu}_D k_{\text{bf}} / D = 4.98 \times 0.613\text{ W/m}\cdot\text{K} / 0.015\text{ m} = 203\text{ W/m}^2\cdot\text{K}$ . From Equation 8.41b

Continued...

### PROBLEM 8.19 (Cont.)

$$\begin{aligned} T_{m,o} &= T_s - (T_s - T_{m,i}) \exp\left(-\frac{\pi DL \bar{h}}{\dot{m} c_{p,\text{bf}}}\right) \\ &= 30^\circ\text{C} - 10^\circ\text{C} \exp\left(-\frac{\pi \times 0.015 \text{ m} \times 6 \text{ m}}{0.015 \text{ kg/s} \times 4179 \text{ J/kg} \cdot \text{K}} 203 \text{ W/m}^2 \cdot \text{K}\right) = 26.0^\circ\text{C} \end{aligned}$$

Therefore the heat transfer rate to the water is

$$q = \dot{m} c_{p,\text{bf}} (T_{m,o} - T_{m,i}) = 0.015 \text{ kg/s} \times 4179 \text{ J/kg} \cdot \text{K} \times (26.0^\circ\text{C} - 20^\circ\text{C}) = 376 \text{ W} \quad <$$

(b) The preceding calculations may be repeated for the nanofluid. The results are:

$$Re_D = 1324, x_{fd,h} = 0.99 \text{ m}, x_{fd,t} = 4.87 \text{ m}$$

The combined entry solution is again appropriate. The remaining results are:

$$G_{zD} = 16.2, \overline{Nu}_D = 4.68, \bar{h} = 220 \text{ W/m}^2 \cdot \text{K}, T_{m,o} = 26.9^\circ\text{C}, \text{ and } q = 369 \text{ W} \quad <$$

**COMMENTS:** (1) The nanofluid of Example 2.2 is water containing  $\text{Al}_2\text{O}_3$  nanoparticles. The thermal conductivity of the nanofluid is 15% greater than that of the base fluid (water). In addition, the convection heat transfer coefficient of the nanofluid is 8% greater than that of the water, and the temperature increase of the nanofluid is 15% higher than for the water. *However, less heat is transferred to the nanofluid than to the water.* This is because the nanofluid suffers from a reduced specific heat relative to the pure water. Any claim that a nanofluid is a better heat transfer medium than its corresponding base fluid because of its larger thermal conductivity is suspect. In this problem, the pure water is the preferred heat transfer fluid if the objective is to maximize the heat transfer rate. In addition, the nanofluid is more costly to produce, and because of its larger viscosity, would suffer from larger pressure drops and higher pumping costs. (2) Use of the Hausen correlation, Equation 8.57 yields  $q = 366 \text{ W}$  and  $362 \text{ W}$  for the water and nanofluid, respectively. Hence, the predictions of the Hausen correlation are within 3% of the predictions using the correlation of Baehr and Stephan. Use of the Hausen correlation also predicts less heat transfer for the nanofluid than for the pure water.

## PROBLEM 8.20

**KNOWN:** Water at prescribed temperature and flow rate enters a 0.25 m diameter, black thin-walled tube of 8-m length, which passes through a large furnace whose walls and air are at a temperature of  $T_{\text{fur}} = T_{\infty} = 700 \text{ K}$ . The convection coefficients for the internal water flow and external furnace air are  $300 \text{ W/m}^2\cdot\text{K}$  and  $50 \text{ W/m}^2\cdot\text{K}$ , respectively.

**FIND:** (a) An expression for the linearized radiation coefficient for the radiation exchange process between the outer surface of the pipe and the furnace walls; represent the tube by an average temperature and explain how to calculate this value, and (b) determine the outlet temperature of the water,  $T_{\text{O}}$ .

**SCHEMATIC:**

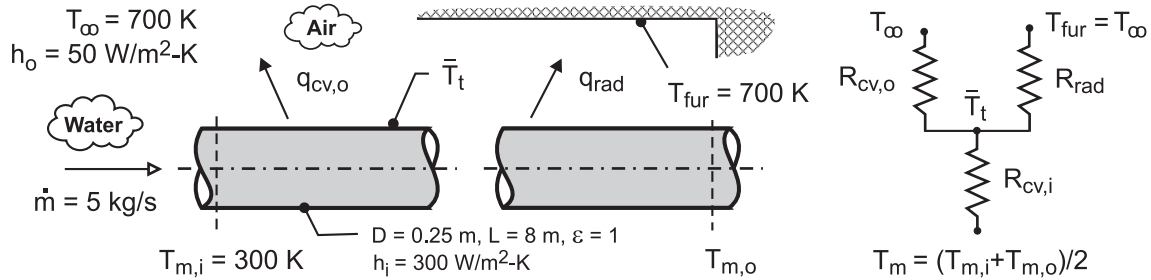

**ASSUMPTIONS:** (1) Steady-state conditions; (2) Tube is small object with large, isothermal surroundings; (3) Furnace air and walls are at the same temperature; (4) Tube is thin-walled with black surface; and (5) Incompressible liquid with negligible viscous dissipation.

**PROPERTIES:** Table A-6, Water ( $T_m = (T_{m,i} + T_{m,o})/2 = 304 \text{ K}$ ):  $c_p = 4178 \text{ J/kg}\cdot\text{K}$ .

**ANALYSIS:** (a) The linearized radiation coefficient follows from Eq. 1.9 with  $\epsilon = 1$ ,

$$\bar{h}_{\text{rad}} = \sigma (\bar{T}_t + T_{\text{fur}}) (\bar{T}_t^2 + T_{\text{fur}}^2)$$

where  $\bar{T}_t$  represents the average tube wall surface temperature, which can be evaluated from an energy balance on the tube as represented by the thermal circuit above.

$$T_m = (T_{m,i} + T_{m,o}) / 2$$

$$R_{\text{tot}} = R_{\text{cv},i} + \frac{1}{1/R_{\text{cv},o} + 1/R_{\text{rad}}}$$

$$\frac{T_m - \bar{T}_t}{R_{\text{cv},i}} = (\bar{T}_t - T_{\text{fur}}) (1/R_{\text{cv},o} + 1/R_{\text{rad}})$$

The thermal resistances, with  $A_s = PL = \pi DL$ , are

$$R_{\text{cv},i} = 1/h_i A_s$$

$$R_{\text{cv},o} = 1/h_o A_s$$

$$R_{\text{rad}} = 1/\bar{h}_{\text{rad}} A_s$$

(b) The outlet temperature can be calculated using the energy balance relation, Eq. 8.45b, with  $T_{\text{fur}} = T_{\infty}$ ,

$$\frac{T_{\infty} - T_{m,o}}{T_{\infty} - T_{m,i}} = \exp\left(-\frac{1}{\dot{m} c_p R_{\text{tot}}}\right)$$

where  $c_p$  is evaluated at  $T_m$ . Using *IHT*, the following results were obtained.

$$R_{\text{cv},i} = 5.31 \times 10^{-4} \text{ K/W} \quad R_{\text{cv},o} = 3.18 \times 10^{-3} \text{ K/W} \quad R_{\text{rad}} = 3.96 \times 10^{-3} \text{ K/W}$$

$$T_m = 304 \text{ K} \quad \bar{T}_t = 396 \text{ K} \quad T_{m,o} = 308 \text{ K} \quad <$$

**COMMENTS:** Since  $T_{\infty} = T_{\text{fur}}$ , it was possible to use Eq. 8.45b with  $R_{\text{tot}}$ . How would you write the energy balance relation if  $T_{\infty} \neq T_{\text{fur}}$ ?

## PROBLEM 8.21

**KNOWN:** Laminar, slug flow in a circular tube with uniform surface heat flux.

**FIND:** Temperature distribution and Nusselt number.

**SCHEMATIC:**

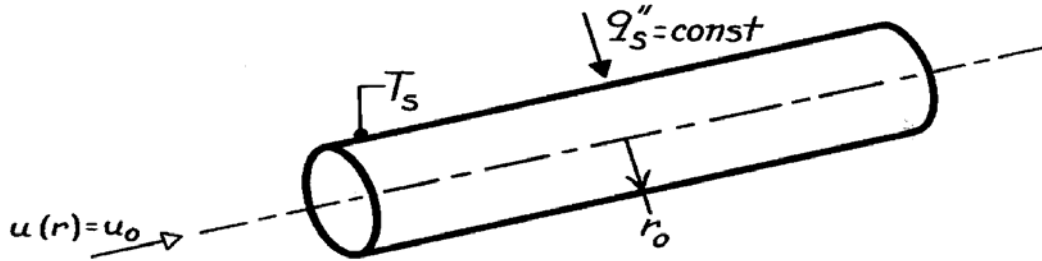

**ASSUMPTIONS:** (1) Steady, incompressible flow, with negligible viscous dissipation, (2) Constant properties, (3) Fully developed, laminar flow, (4) Uniform surface heat flux.

**ANALYSIS:** With  $v = 0$  for fully developed flow and  $\partial T / \partial x = dT_m / dx = \text{const}$ , from Eqs. 8.32 and 8.39, the energy equation, Eq. 8.48, reduces to

$$u_0 \frac{dT_m}{dx} = \frac{\alpha}{r} \frac{\partial}{\partial r} \left( r \frac{\partial T}{\partial r} \right).$$

Integrating twice, it follows that

$$T(r) = \frac{u_0}{\alpha} \frac{dT_m}{dx} \frac{r^2}{4} + C_1 \ln(r) + C_2.$$

Since  $T(0)$  must remain finite,  $C_1 = 0$ . Hence, with  $T(r_0) = T_s$

$$C_2 = T_s - \frac{u_0}{\alpha} \frac{dT_m}{dx} \frac{r_0^2}{4} \quad T(r) = T_s - \frac{u_0}{4\alpha} \frac{dT_m}{dx} (r_0^2 - r^2). \quad <$$

From Eq. 8.26, with  $u_m = u_0$ ,

$$\begin{aligned} T_m &= \frac{2}{r_0^2} \int_0^{r_0} T r \, dr = \frac{2}{r_0^2} \int_0^{r_0} \left[ T_s r - \frac{u_0}{4\alpha} \frac{dT_m}{dx} (r_0^2 - r^2) \right] dr \\ T_m &= \frac{2}{r_0^2} \left[ T_s \frac{r_0^2}{2} - \frac{u_0}{4\alpha} \frac{dT_m}{dx} \left( \frac{r_0^4}{2} - \frac{r_0^4}{4} \right) \right] = T_s - \frac{u_0 r_0^2}{8\alpha} \frac{dT_m}{dx}. \end{aligned}$$

From Eq. 8.27 and Fourier's law,

$$h = \frac{q_s''}{T_s - T_m} = \frac{k \frac{\partial T}{\partial r} \Big|_{r_0}}{T_s - T_m}$$

hence,

$$h = \frac{k \left( \frac{u_0 r_0}{2\alpha} \right) \frac{dT_m}{dx}}{\frac{u_0 r_0^2}{8\alpha} \frac{dT_m}{dx}} = \frac{4k}{r_0} = \frac{8k}{D} \quad \overline{\text{Nu}}_D = \frac{hD}{k} = 8. \quad <$$



### PROBLEM 8.22

**KNOWN:** Heat transfer between fluid flow over a tube and flow through the tube.

**FIND:** Axial variation of mean temperature for inner flow.

**SCHEMATIC:**

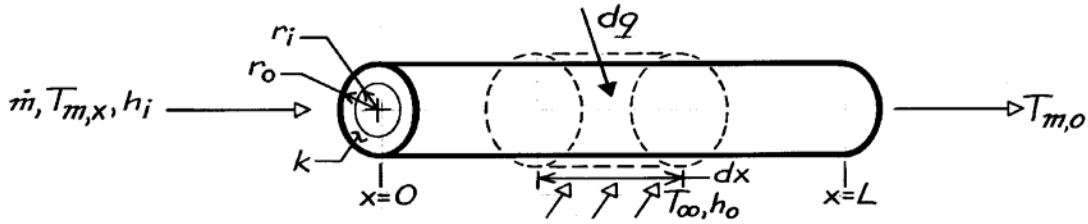

**ASSUMPTIONS:** (1) Applicability of Eq. 8.34, (2) Negligible axial conduction, (3) Constant  $c_p$ , (4) Uniform  $T_\infty$ .

**ANALYSIS:** From Eq. 8.36,

$$dq = \dot{m} c_p dT_m$$

with

$$dq = U dA (T_\infty - T_m) = UP (T_\infty - T_m) dx.$$

The overall heat transfer coefficient may be defined in terms of the inner or outer surface area, with

$$U_i P_i = U_o P_o.$$

For the inner surface, from Eq. 3.36,

$$U_i = \left[ \frac{1}{h_i} + \frac{r_i}{k} \ln \frac{r_o}{r_i} + \frac{r_i}{r_o} \frac{1}{h_o} \right]^{-1}.$$

Hence,

$$\frac{dT_m}{T_\infty - T_m} = + \frac{UP}{\dot{m} c_p} dx$$

or, with  $\Delta T \equiv T_\infty - T_m$ ,

$$\int_{\Delta T_i}^{\Delta T_o} \frac{d(\Delta T)}{\Delta T} = - \frac{P}{\dot{m} c_p} \int_0^L U dx.$$

Hence,

$$\ln \frac{\Delta T_o}{\Delta T_i} = - \frac{PL}{\dot{m} c_p} \left( \frac{1}{L} \int_0^L U dx \right)$$

$$\frac{T_\infty - T_{m,o}}{T_\infty - T_{m,i}} = \exp \left( - \frac{PL}{\dot{m} c_p} \bar{U} \right).$$

<

**COMMENTS:** The development and results parallel those for a constant surface temperature, with  $\bar{U}$  and  $T_\infty$  replacing  $\bar{h}$  and  $T_s$ .

## PROBLEM 8.23

**KNOWN:** Thin-walled tube experiences sinusoidal heat flux distribution on the wall.

**FIND:** (a) Total rate of heat transfer from the tube to the fluid,  $q$ , (b) Fluid outlet temperature,  $T_{m,o}$ , (c) Axial distribution of the wall temperature  $T_s(x)$  and (d) Magnitude and position of the highest wall temperature, and (e) For prescribed conditions, calculate and plot the mean fluid and surface temperatures,  $T_m(x)$  and  $T_s(x)$ , respectively, as a function of distance along the tube; identify features of the distributions; explore the effect of  $\pm 25\%$  changes in the convection coefficient on the distributions.

**SCHEMATIC:**

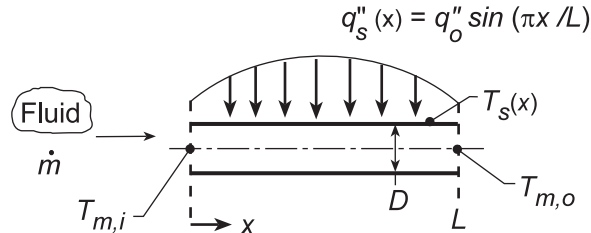

**ASSUMPTIONS:** (1) Steady-state conditions, (2) Applicability of Eq. 8.34, (3) Turbulent, fully developed flow.

**ANALYSIS:** (a) The total rate of heat transfer from the tube to the fluid is

$$q = \int_0^L q_s'' P dx = q_o'' \pi D \int_0^L \sin(\pi x/L) dx = q_o'' \pi D (L/\pi) [-\cos(\pi x/L)]_0^L = 2DLq_o'' \quad (1) <$$

(b) The fluid outlet temperature follows from the overall energy balance with knowledge of the total heat rate,

$$q = \dot{m}c_p (T_{m,o} - T_{m,i}) = 2DLq_o'' \quad T_{m,o} = T_{m,i} + (2DLq_o''/\dot{m}c_p) \quad (2) <$$

(c) The axial distribution of the wall temperature can be determined from the rate equation

$$q_s'' = h [T_s(x) - T_m(x)] \quad T_{s,x} = T_{m,x}(x) + q_s''/h \quad (3)$$

where, by combining expressions of parts (a) and (b),  $T_{m,x}(x)$  is

$$\int_0^x q_s'' P dx = \dot{m}c_p (T_{m,x} - T_{m,i})$$

$$T_{m,x} = T_{m,i} + \frac{q_o'' \pi D}{\dot{m}c_p} \int_0^x \sin(\pi x/L) dx = T_{m,i} + \frac{DLq_o''}{\dot{m}c_p} [1 - \cos(\pi x/L)] \quad (4)$$

Hence, substituting Eq. (4) into (3), find

$$T_s(x) = T_{m,i} + \frac{DLq_o''}{\dot{m}c_p} [1 - \cos(\pi x/L)] + \frac{q_o''}{h} \sin(\pi x/L) \quad (5) <$$

(d) To determine the location of the maximum wall temperature  $x'$  where  $T_x(x') = T_{s,max}$ , set

$$\frac{dT_s(x)}{dx} = 0 = \frac{d}{dx} \left\{ \frac{DLq_o''}{\dot{m}c_p} [1 - \cos(\pi x/L)] + \frac{q_o''}{h} \sin(\pi x/L) \right\}$$

$$\frac{DLq_o''}{\dot{m}c_p} \cdot \frac{\pi}{L} \cdot \sin(\pi x'/L) + \frac{q_o''}{h} \cdot \frac{\pi}{L} \cdot \cos(\pi x'/L) = 0 \quad \tan(\pi x'/L) = -\frac{q_o''/h}{DLq_o''/\dot{m}c_p} = -\frac{\dot{m}c_p}{DLh}$$

Continued...

**PROBLEM 8.23 (Cont.)**

$$x' = \frac{L}{\pi} \tan^{-1}(-\dot{m}c_p/DLh) \quad (6) <$$

At this location, the wall temperature is

$$T_{s,\max} = T_s(x') = T_{m,i} + \frac{DLq_o''}{\dot{m}c_p} [1 - \cos(\pi x'/L)] + \frac{q_o''}{h} \sin(\pi x'/L) \quad (7) <$$

(e) Consider the prescribed conditions for which to compute and plot  $T_m(x)$  and  $T_s(x)$ ,

$D = 40 \text{ mm}$	$\dot{m} = 0.025 \text{ kg/s}$	$h = 1000 \text{ W/m}^2\text{K}$	$q_o'' = 10,000 \text{ W/m}^2$
$L = 4 \text{ m}$	$c_p = 4180 \text{ J/kg}\cdot\text{K}$	$T_{m,i} = 25^\circ\text{C}$	

Using Eqs. (4) and (5) in IHT, the results are plotted below.

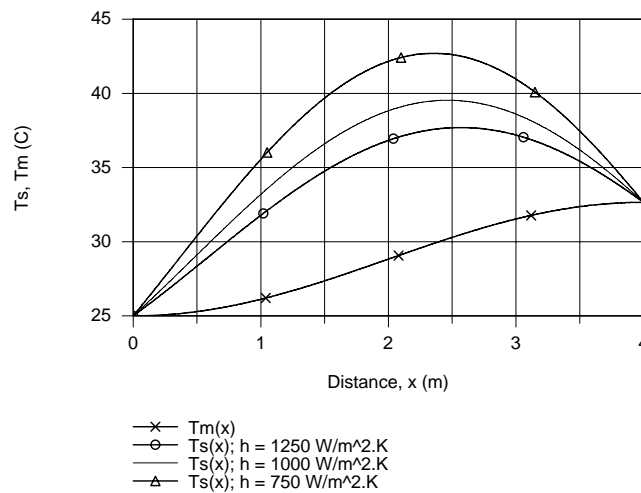

The effect of a lower convection coefficient is to increase the wall temperature. The position of the maximum temperature,  $T_{s,\max}$ , moves away from the tube exit with decreasing convection coefficient.

**COMMENTS:** (1) Because the flow is fully developed and turbulent, assuming  $h$  is constant along the entire length of the tube is reasonable.

(2) To determine whether the  $T_x(x)$  distribution has a maximum (rather than a minimum), you should evaluate  $d^2T_s(x)/dx^2$  to show the value is indeed negative.

## PROBLEM 8.24

**KNOWN:** Water is heated in a tube having a wall flux that is dependent upon the wall temperature.

**FIND:** (a) Beginning with a properly defined differential control volume in the tube, derive expressions that can be used to obtain the temperatures for the water and the wall surface as a function of distance from the inlet,  $T_m(x)$  and  $T_s(x)$ , respectively; (b) Using a numerical integration scheme, calculate and plot the temperature distributions,  $T_m(x)$  and  $T_s(x)$ , on the same graph. Identify and comment on the main features of the distributions; and (c) Calculate the total heat transfer rate to the water.

**SCHEMATIC:**

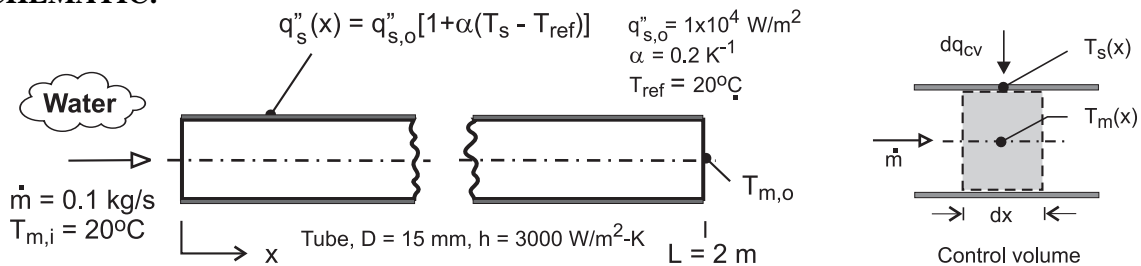

**ASSUMPTIONS:** (1) Steady-state conditions, (2) Fully developed flow and thermal conditions, (3) No losses to the outer surface of the tube, (3) Constant properties, and (4) Incompressible liquid with negligible viscous dissipation .

**PROPERTIES:** Table A-6, Water ( $\bar{T}_m = (T_{m,i} + T_{m,o})/2 = 300 \text{ K}$ ):  $c_p = 4179 \text{ J/kg}\cdot\text{K}$

**ANALYSIS:** (a) The properly defined control volume of perimeter  $P = \pi D$  shown in the above schematic follows from Fig. 8.6. The energy balance on the CV includes advection, convection at the inner tube surface, and the heat flux dissipated in the tube wall. (See Eq. 8.37).

$$\dot{m} c_p \frac{dT_m}{dx} = q_s''(x) P = h P [T_s(x) - T_m(x)] \quad (1,2)$$

where  $q_s''(x)$  is dependent upon  $T_s(x)$  according to the relation

$$q_s''(x) = q_{s,o}'' [1 + \alpha(T_s(x) - T_{ref})] \quad (3)$$

(b) Eqs. (1 and 2) with Eq. (3) can be solved by numerical integration using the Der function in *IHT* as shown in Comment 1. The temperature distributions for the water and wall surface are plotted below.

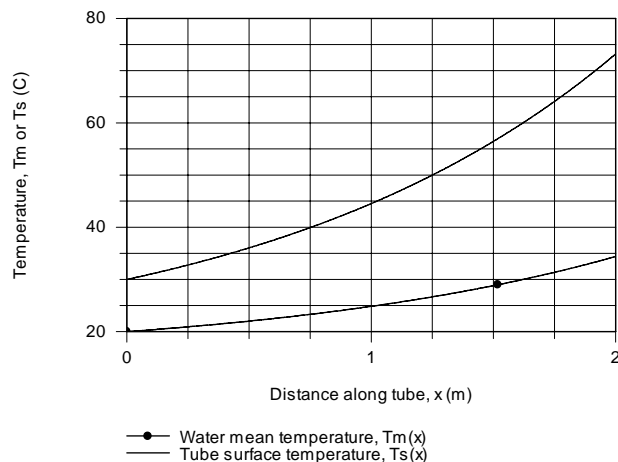

Continued ...

### PROBLEM 8.24 (Cont.)

(c) The total heat transfer to the water can be evaluated from an overall energy balance on the water,

$$q = \dot{m} c_p (T_{m,o} - T_{m,i}) \quad (4)$$

$$q = 0.1 \text{ kg/s} \times 4179 \text{ J/kg} \cdot \text{K} (34.4 - 20) \text{ K} = 6018 \text{ W} \quad <$$

Alternatively, the heat rate can be evaluated by integration of the heat flux from the tube surface over the length of the tube,

$$q = \int_0^L q_s''(x) P dx \quad (5)$$

where  $q_s''(x)$  is given by Eq. (3), and  $T_s(x)$  and  $T_m(x)$  are determined from the differential form of the energy equation, Eqs. (1) and (2). The result as shown in the *IHT* code below is 6005 W.

**COMMENTS:** (1) Note that  $T_m(x)$  increases with distance greater than linearly, as expected since  $q_s''(x)$  does. Also as expected, the difference,  $T_s(x) - T_m(x)$ , likewise increases with distance greater than linearly.

(2) In the foregoing analysis,  $c_p$  is evaluated at the mean fluid temperature  $T_m = (T_{m,i} + T_{m,o})/2$ .

(3) The *IHT* code representing the foregoing equations to calculate and plot the temperature distribution and to calculate the total heat rate to the water is shown below.

```

/* Results: integration for distributions; conditions at x = 2 m
F_xTs Ts q' q's_x x Tm
11.64 73.18 5483 1.164E5 2 34.39
3 30 1414 3E4 0 20 */

/* Results: heat rate by energy balances on fluid and tube surface
q_eb q_hf
6018 6005 */

/* Results: for evaluating cp at Tm
Ts cp q's_x x Tm
73.31 4179 1.166E5 2 34.44
30 4179 3E4 0 20 */

// Energy balances
mdot * cp * der(Tm,x) = q' // Energy balance, Eq. 8.37
q' = q's_x * P
q's_x = q'o * F_xTs
q' = h * P * (Ts - Tm) // Convection rate equation
P = pi * D

// Surface heat flux specification
F_xTs = (1 + alpha * (Ts - Tref))
alpha = 0.2
Tref = 20

// Overall heat rate
// Energy balance on the fluid
q_eb = mdot * cp * (Tmo - Tmi)
Tmi = 20
Tmo = 34.4 // From initial solve

// Integration of the surface heat flux
q_hf = q'o * P * INTEGRAL(F_xTs, x)

// Input variables
mdot = 0.1
D = 0.015
h = 3000
q'o = 1.0e4
// L = 2 // Limit of integration over x
// Tmi = 20 // Initial condition for integration

// Water property functions :T dependence, From Table A.6
// Units: T(K), p(bars);
xx = 0 // Quality (0=sat liquid or 1=sat vapor)
cp = cp_Tx("Water",Tmm,xx) // Specific heat, J/kg.K
Tmm = (20 + 34.4) / 2 + 273

```

## PROBLEM 8.25

**KNOWN:** Inlet temperature and flowrate of oil flowing through a tube of prescribed surface temperature and geometry.

**FIND:** (a) Oil outlet temperature and total heat transfer rate, and (b) Effect of flowrate.

**SCHEMATIC:**

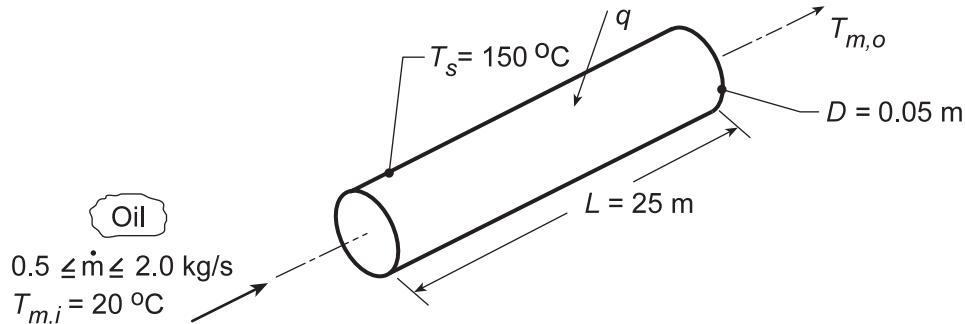

**ASSUMPTIONS:** (1) Negligible temperature drop across tube wall, (2) Incompressible liquid with negligible viscous dissipation.

**PROPERTIES:** Table A.5, Engine oil (assume  $T_{m,o} = 140^\circ\text{C}$ , hence  $\bar{T}_m = 80^\circ\text{C} = 353 \text{ K}$ ):  $\rho = 852 \text{ kg/m}^3$ ,  $\nu = 37.5 \times 10^{-6} \text{ m}^2/\text{s}$ ,  $k = 138 \times 10^{-3} \text{ W/m}\cdot\text{K}$ ,  $\text{Pr} = 490$ ,  $\mu = \rho \cdot \nu = 0.032 \text{ kg/m}\cdot\text{s}$ ,  $c_p = 2131 \text{ J/kg}\cdot\text{K}$ .

**ANALYSIS:** (a) For constant surface temperature the oil outlet temperature may be obtained from Eq. 8.41b. Hence

$$T_{m,o} = T_s - (T_s - T_{m,i}) \exp\left(-\frac{\pi D L \bar{h}}{\dot{m} c_p}\right)$$

To determine  $\bar{h}$ , first calculate  $\text{Re}_D$  from Eq. 8.6,

$$\text{Re}_D = \frac{4\dot{m}}{\pi D \mu} = \frac{4(0.5 \text{ kg/s})}{\pi(0.05 \text{ m})(0.032 \text{ kg/m}\cdot\text{s})} = 398$$

Hence the flow is laminar. Moreover, from Eq. 8.23 the thermal entry length is

$$x_{fd,t} \approx 0.05 D \text{Re}_D \text{Pr} = 0.05(0.05 \text{ m})(398)(490) = 486 \text{ m}.$$

Since  $L = 25 \text{ m}$  the flow is far from being thermally fully developed. Since  $\text{Pr} > 5$ ,  $\bar{h}$  may be determined from Eq. 8.57

$$\overline{\text{Nu}}_D = 3.66 + \frac{0.0668 \text{Gz}_D}{1 + 0.04 \text{Gz}_D^{2/3}}.$$

With  $\text{Gz}_D = (D/L)\text{Re}_D\text{Pr} = (0.05/25)398 \times 490 = 390$ , it follows that

$$\overline{\text{Nu}}_D = 3.66 + \frac{26}{1 + 2.14} = 11.95.$$

Hence,  $\bar{h} = \overline{\text{Nu}}_D \frac{k}{D} = 11.95 \frac{0.138 \text{ W/m}\cdot\text{K}}{0.05 \text{ m}} = 33 \text{ W/m}^2 \cdot \text{K}$  and it follows that

Continued...

### PROBLEM 8.25 (Cont.)

$$T_{m,o} = 150^\circ\text{C} - (150^\circ\text{C} - 20^\circ\text{C}) \exp\left[-\frac{\pi(0.05\text{ m})(25\text{ m})}{0.5\text{ kg/s} \times 2131\text{ J/kg}\cdot\text{K}} \times 33\text{ W/m}^2\cdot\text{K}\right]$$

$$T_{m,o} = 35^\circ\text{C}.$$

From the overall energy balance, Eq. 8.34, it follows that

$$q = \dot{m}c_p(T_{m,o} - T_{m,i}) = 0.5\text{ kg/s} \times 2131\text{ J/kg}\cdot\text{K} \times (35 - 20)^\circ\text{C}$$

$$q = 15,980\text{ W}.$$

The value of  $T_{m,o}$  has been grossly overestimated in evaluating the properties. The properties should be re-evaluated at  $\bar{T} = (20 + 35)/2 = 27^\circ\text{C}$  and the calculations repeated. Iteration should continue until satisfactory convergence is achieved between the calculated and assumed values of  $T_{m,o}$ . Following such a procedure, one would obtain  $T_{m,o} = 36.4^\circ\text{C}$ ,  $Re_D = 27.8$ ,  $\bar{h} = 32.8\text{ W/m}^2\cdot\text{K}$ , and  $q = 15,660\text{ W}$ . The small effect of reevaluating the properties is attributed to the compensating effects on  $Re_D$  (a large decrease) and  $Pr$  (a large increase).

(b) The effect of flowrate on  $T_{m,o}$  and  $q$  was determined by using the appropriate IHT *Correlations* and *Properties* Toolpads.

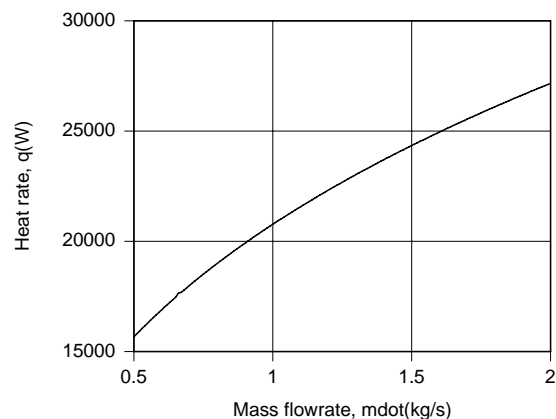
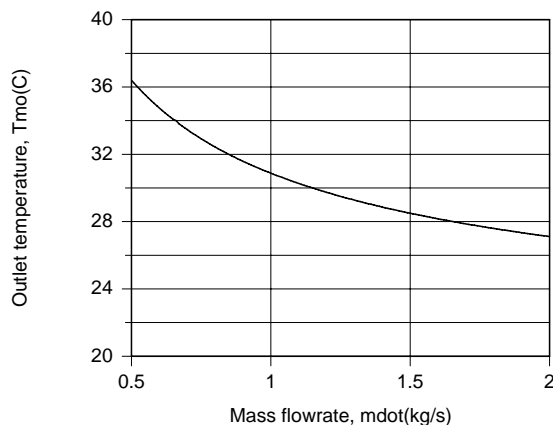

The heat rate increases with increasing  $\dot{m}$  due to the corresponding increase in  $Re_D$  and hence  $\bar{h}$ . However, the increase is not proportional to  $\dot{m}$ , causing  $(T_{m,o} - T_{m,i}) = q/\dot{m}c_p$ , and hence  $T_{m,o}$  to decrease with increasing  $\dot{m}$ . The maximum heat rate corresponds to the maximum flowrate ( $\dot{m} = 0.20\text{ kg/s}$ ).

**COMMENTS:** Note that significant error would be introduced by assuming fully developed thermal conditions and  $\overline{Nu}_D = 3.66$ . The flow remains well within the laminar region over the entire range of  $\dot{m}$ .

## PROBLEM 8.26

**KNOWN:** Inlet temperature and flowrate of oil moving through a tube of prescribed diameter and surface temperature.

**FIND:** (a) Oil outlet temperature  $T_{m,o}$  for two tube lengths, 5 m and 100 m, and log mean and arithmetic mean temperature differences, (b) Effect of  $L$  on  $T_{m,o}$  and  $\overline{Nu}_D$ .

**SCHEMATIC:**

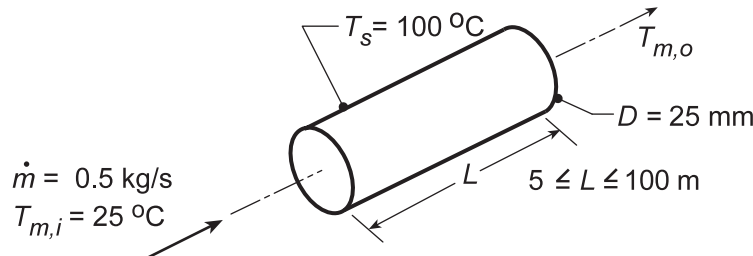

**ASSUMPTIONS:** (1) Steady-state conditions, (2) Incompressible liquid with negligible viscous dissipation, (3) Constant properties.

**PROPERTIES:** Table A.4, Oil (330 K):  $c_p = 2035 \text{ J/kg}\cdot\text{K}$ ,  $\mu = 0.0836 \text{ N}\cdot\text{s/m}^2$ ,  $k = 0.141 \text{ W/m}\cdot\text{K}$ ,  $Pr = 1205$ .

**ANALYSIS:** (a) Using Eqs. 8.41b and 8.6

$$T_{m,o} = T_s - (T_s - T_{m,i}) \exp\left(-\frac{\pi DL \bar{h}}{\dot{m} c_p}\right)$$

$$Re_D = \frac{4\dot{m}}{\pi D \mu} = \frac{4 \times 0.5 \text{ kg/s}}{\pi \times 0.025 \text{ m} \times 0.0836 \text{ N}\cdot\text{s/m}^2} = 304.6$$

With  $x_{fd,h} = 0.05DRe_D = 0.4 \text{ m}$ , it is reasonable to assume the flow is hydrodynamically fully developed. However, with  $x_{fd,t} = x_{fd,h}Pr = 495 \text{ m}$ , the flow is thermally developing. Since thermal entry length effects will be significant and  $Pr > 5$ , use Eq. 8.57 with Eq. 8.56 for the Graetz number:

$$\bar{h} = \frac{k}{D} \left[ 3.66 + \frac{0.0688(D/L)Re_D Pr}{1 + 0.04[(D/L)Re_D Pr]^{2/3}} \right] = \frac{0.141 \text{ W/m}\cdot\text{K}}{0.025 \text{ m}} \left[ 3.66 + \frac{2.45 \times 10^4 D/L}{1 + 205(D/L)^{2/3}} \right]$$

For  $L = 5 \text{ m}$ ,  $\bar{h} = 5.64(3.66 + 17.51) = 119 \text{ W/m}^2 \cdot \text{K}$ , hence

$$T_{m,o} = 100^\circ\text{C} - (75^\circ\text{C}) \exp\left(-\frac{\pi \times 0.025 \text{ m} \times 5 \text{ m} \times 119 \text{ W/m}^2 \cdot \text{K}}{0.5 \text{ kg/s} \times 2035 \text{ J/kg}\cdot\text{K}}\right) = 28.4^\circ\text{C} \quad <$$

For  $L = 100 \text{ m}$ ,  $\bar{h} = 5.64(3.66 + 3.38) = 40 \text{ W/m}^2 \cdot \text{K}$ ,  $T_{m,o} = 44.9^\circ\text{C}$ . <

Also, for  $L = 5 \text{ m}$ ,

$$\Delta T_{\ell m} = \frac{\Delta T_o - \Delta T_i}{\ln(\Delta T_o / \Delta T_i)} = \frac{71.6 - 75}{\ln(71.6/75)} = 73.3^\circ\text{C} \quad \Delta T_{am} = (\Delta T_o + \Delta T_i)/2 = 73.3^\circ\text{C} \quad <$$

For  $L = 100 \text{ m}$ ,  $\Delta T_{\ell m} = 64.5^\circ\text{C}$ ,  $\Delta T_{am} = 65.1^\circ\text{C}$  <

(b) The effect of tube length on the outlet temperature and Nusselt number was determined by using the *Correlations and Properties* Toolpads of IHT.

Continued...



### PROBLEM 8.26 (Cont.)

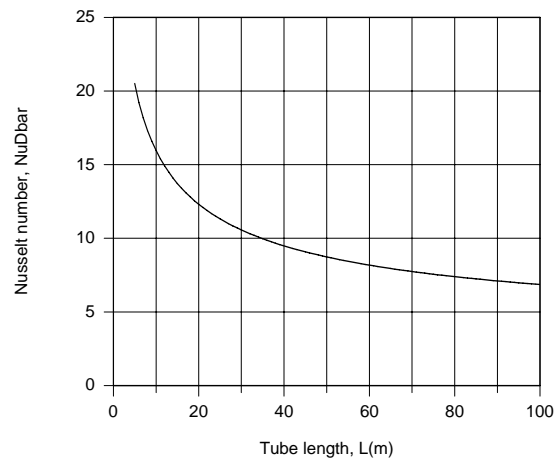
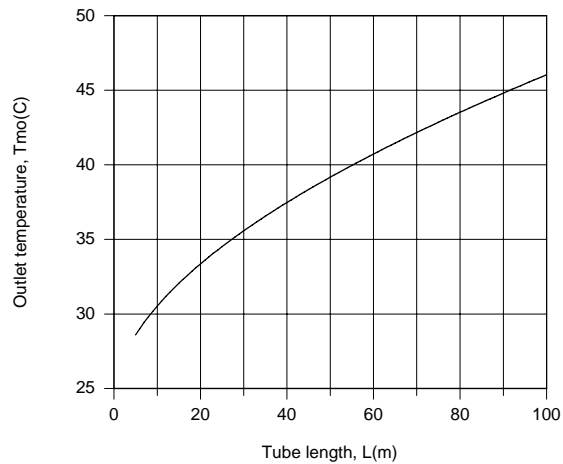

The outlet temperature approaches the surface temperature with increasing  $L$ , but even for  $L = 100$  m,  $T_{m,o}$  is well below  $T_s$ . Although  $\overline{Nu}_D$  decays with increasing  $L$ , it is still well above the fully developed value of  $Nu_{D,fd} = 3.66$ .

**COMMENTS:** (1) The average, mean temperature,  $\overline{T}_m = 330$  K, was significantly overestimated in part (a). The accuracy may be improved by evaluating the properties at a lower temperature. (2) Use of  $\Delta T_{am}$  instead of  $\Delta T_{\ell m}$  is reasonable for small to moderate values of  $(T_{m,i} - T_{m,o})$ . For large values of  $(T_{m,i} - T_{m,o})$ ,  $\Delta T_{\ell m}$  should be used.

### PROBLEM 8.27

**KNOWN:** Inlet and outlet temperatures and velocity of fluid flow in tube. Tube diameter and length.

**FIND:** Surface heat flux and temperatures at  $x = 0.5$  and  $10$  m.

**SCHEMATIC:**

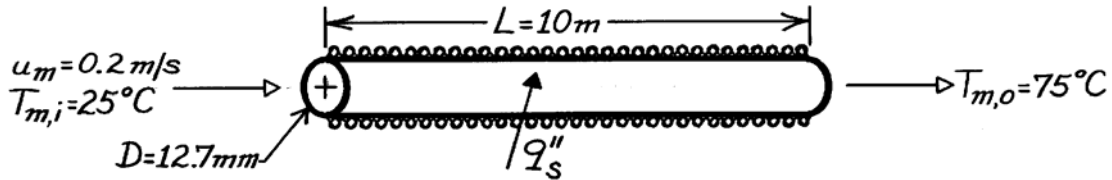

**ASSUMPTIONS:** (1) Steady-state conditions, (2) Constant properties, (3) Negligible heat loss to surroundings, (4) Incompressible liquid with negligible viscous dissipation, (5) Negligible axial conduction.

**PROPERTIES:** Pharmaceutical (given):  $\rho = 1000 \text{ kg/m}^3$ ,  $c_p = 4000 \text{ J/kg}\cdot\text{K}$ ,  $\mu = 2 \times 10^{-3} \text{ kg/s}\cdot\text{m}$ ,  $k = 0.80 \text{ W/m}\cdot\text{K}$ ,  $\text{Pr} = 10$ .

**ANALYSIS:** With

$$\dot{m} = \rho VA = 1000 \text{ kg/m}^3 (0.2 \text{ m/s}) \pi (0.0127 \text{ m})^2 / 4 = 0.0253 \text{ kg/s}$$

Eq. 8.34 yields

$$q = \dot{m} c_p (T_{m,o} - T_{m,i}) = 0.0253 \text{ kg/s} (4000 \text{ J/kg}\cdot\text{K}) 50 \text{ K} = 5060 \text{ W}.$$

The required heat flux is then

$$q_s'' = q/A_s = 5060 \text{ W} / \pi (0.0127 \text{ m}) 10 \text{ m} = 12,682 \text{ W/m}^2. \quad <$$

With

$$\text{Re}_D = \rho VD / \mu = 1000 \text{ kg/m}^3 (0.2 \text{ m/s}) 0.0127 \text{ m} / 2 \times 10^{-3} \text{ kg/s}\cdot\text{m} = 1270$$

the flow is laminar and Eq. 8.23 yields

$$x_{fd,t} = 0.05 \text{Re}_D \text{Pr} D = 0.05 (1270) 10 (0.0127 \text{ m}) = 8.06 \text{ m}.$$

Hence, with fully developed hydrodynamic and thermal conditions at  $x = 10$  m, Eq. 8.53 yields

$$h(10 \text{ m}) = \text{Nu}_{D,fd} (k/D) = 4.36 (0.80 \text{ W/m}\cdot\text{K} / 0.0127 \text{ m}) = 274.6 \text{ W/m}^2 \cdot \text{K}.$$

Hence, from Newton's law of cooling,

$$T_{s,o} = T_{m,o} + (q_s'' / h) = 75^\circ\text{C} + (12,682 \text{ W/m}^2 / 274.6 \text{ W/m}^2 \cdot \text{K}) = 121^\circ\text{C}. \quad <$$

At  $x = 0.5$  m,  $(x/D) / (\text{Re}_D \text{Pr}) = 0.0031$  and Figure 8.10 yields  $\text{Nu}_D \approx 8$  for a thermal entry region with uniform surface heat flux. Hence,  $h(0.5 \text{ m}) = 503.9 \text{ W/m}^2 \cdot \text{K}$  and, since  $T_m$  increases linearly with  $x$ ,  $T_m(x = 0.5 \text{ m}) = T_{m,i} + (T_{m,o} - T_{m,i}) (x/L) = 27.5^\circ\text{C}$ . It follows that

$$T_s(x = 0.5 \text{ m}) \approx 27.5^\circ\text{C} + (12,682 \text{ W/m}^2 / 503.9 \text{ W/m}^2 \cdot \text{K}) = 52.7^\circ\text{C}. \quad <$$

## PROBLEM 8.28

**KNOWN:** Oil at 75°C enters a single-tube preheater of 10-mm diameter and 5-m length; tube surface maintained at 175°C by swirling combustion gases.

**FIND:** Determine the flow rate and heat transfer rate when the outlet temperature is 100°C.

**SCHEMATIC:**

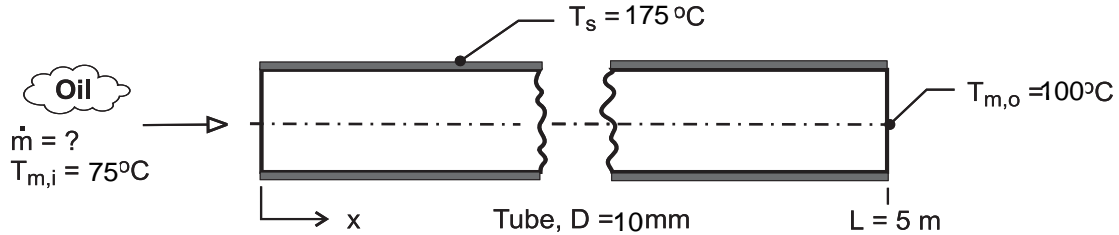

**ASSUMPTIONS:** (1) Laminar flow, (2) Tube wall is isothermal, (3) Incompressible liquid with negligible viscous dissipation, (4) Constant properties.

**PROPERTIES:** Table A-5, Engine oil, new ( $T_m = (T_{m,i} + T_{m,o})/2 = 361 \text{ K}$ ):  $\rho = 847.5 \text{ kg/m}^3$ ,  $c_p = 2163 \text{ J/kg}\cdot\text{K}$ ,  $\nu = 2.931 \times 10^{-5} \text{ m}^2/\text{s}$ ,  $k = 0.1379 \text{ W/m}\cdot\text{K}$ ,  $\text{Pr} = 390.2$ ,  $\mu = 0.0245$ .

**ANALYSIS:** The overall energy balance, Eq. 8.34, and rate equation, Eq. 8.41b, are

$$q = \dot{m} c_p (T_{m,o} - T_{m,i}) \quad (1)$$

$$\frac{T_s - T_{m,o}}{T_s - T_{m,i}} = \exp\left(-\frac{PL\bar{h}}{\dot{m} c_p}\right) \quad (2)$$

Not knowing the flow rate  $\dot{m}$ , the Reynolds number cannot be calculated. Assume that the flow is laminar. Since  $\text{Pr} > 5$ , the average convection coefficient can be estimated using the Hausen correlation, Eq. 8.57, with Eq. 8.56 for the Graetz number:

$$\overline{\text{Nu}}_D = 3.66 + \frac{0.0668(D/L) \text{Re}_D \text{Pr}}{1 + 0.04[(D/L) \text{Re}_D \text{Pr}]^{2/3}} \quad (3)$$

where all properties are evaluated at  $T_m = (T_{m,i} + T_{m,o})/2$ . The Reynolds number follows from Eq. 8.6,

$$\text{Re}_D = 4\dot{m} / \pi D \mu \quad (4)$$

A tedious trial-and-error solution is avoided by using *IHT* to solve the system of equations with the following result:

$\text{Re}_D$	$\overline{\text{Nu}}_D$	$\bar{h}_D \text{ (W/m}^2\cdot\text{K)}$	$q \text{ (W)}$	$\dot{m} \text{ (kg/h)}$	
130	7.25	100	1360	90	<

Note that the flow is laminar, and evaluating  $x_{fd,t}$  using Eq. 8.23, find  $x_{fd,t} = 25 \text{ m}$ , so the flow is not thermally fully developed.

**COMMENT:** Use of the Baehr and Stephan correlation for the combined entry problem yields the identical values. Hence it may also be used.

## PROBLEM 8.29

**KNOWN:** Oil flow rate. Pipe diameter. Inlet, outlet, and pipe surface temperatures.

**FIND:** Length of tube required to achieve desired outlet temperature.

**SCHEMATIC:**

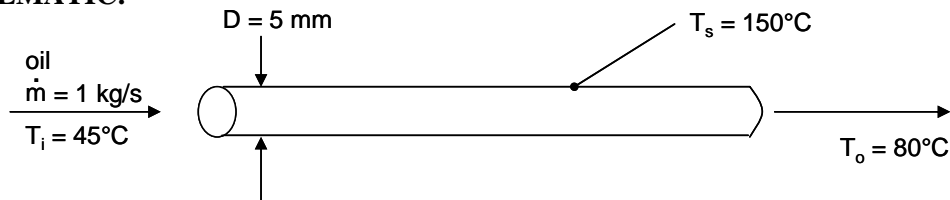

**ASSUMPTIONS:** (1) Steady-state, (2) Incompressible flow, (3) Negligible viscous dissipation.

**PROPERTIES:** Table A-5, Engine oil ( $T_i = 45^\circ\text{C} = 318\text{ K}$ ):  $\mu_i = 16.3 \times 10^{-2}\text{ N}\cdot\text{s}/\text{m}^2$ ; ( $T_o = 80^\circ\text{C} = 353\text{ K}$ ):  $\mu_o = 3.25 \times 10^{-2}\text{ N}\cdot\text{s}/\text{m}^2$ .

**ANALYSIS:** We begin by calculating the Reynolds numbers at the inlet and outlet, from Equation 8.6,

$$\text{Re}_{Di} = \frac{4 \dot{m}}{\pi D \mu_i} = \frac{4 \times 1 \text{ kg/s}}{\pi \times 0.005 \text{ m} \times 16.3 \times 10^{-2} \text{ N}\cdot\text{s}/\text{m}^2} = 1560$$

$$\text{Re}_{Do} = \frac{4 \times 1 \text{ kg/s}}{\pi \times 0.005 \text{ m} \times 3.25 \times 10^{-2} \text{ N}\cdot\text{s}/\text{m}^2} = 7840$$

Therefore the flow is laminar at the inlet and turbulent at the outlet. The transition occurs when  $\text{Re}_D = 2300$ , that is, where

$$\mu = \frac{4 \dot{m}}{\pi D 2300} = \frac{4 \times 1 \text{ kg/s}}{\pi \times 0.005 \text{ m} \times 2300} = 11.1 \times 10^{-2} \text{ N}\cdot\text{s}/\text{m}^2$$

From Table A-5, this occurs at a transition temperature of  $T_{m,t} = 325\text{ K} = 52^\circ\text{C}$ . Now we proceed to analyze separately the heat transfer in the laminar and turbulent regions.

Laminar Region. The mean temperature in the laminar region is  $\bar{T}_{m1} = (45^\circ\text{C} + 52^\circ\text{C})/2 = 48.5^\circ\text{C} = 321.5\text{ K}$ . The properties are  $c_{p1} = 1999\text{ J}/\text{kg}\cdot\text{K}$ ,  $\mu_1 = 13.2 \times 10^{-2}\text{ N}\cdot\text{s}/\text{m}^2$ ,  $k_1 = 0.143\text{ W}/\text{m}\cdot\text{K}$ ,  $\text{Pr}_1 = 1851$ . We recalculate the Reynolds number,

$$\text{Re}_{D1} = \frac{4 \dot{m}}{\pi D \mu_1} = \frac{4 \times 1 \text{ kg/s}}{\pi \times 0.005 \text{ m} \times 13.2 \times 10^{-2} \text{ N}\cdot\text{s}/\text{m}^2} = 1930$$

The hydrodynamic and thermal entry lengths are given by

$$x_{fd,h} = 0.05 \text{ Re}_{Di} D = 0.05 \times 1930 \times 0.005 \text{ m} = 0.48 \text{ m}$$

$$x_{fd,t} = x_{fd,h} \cdot \text{Pr}_1 = 0.48 \text{ m} \times 1851 = 890 \text{ m}$$

Based on this information, we assume the flow is hydrodynamically developed but thermally developing, and use Equations 8.56 and 8.57 for the Nusselt number (with  $\text{Pr} > 5$ ),

$$\overline{\text{Nu}}_{D1} = \overline{h}_1 D / k_1 = 3.66 + \frac{0.0668 (D/L_1) \text{Re}_{D1} \text{Pr}_1}{1 + 0.04 [(D/L_1) \text{Re}_{D1} \text{Pr}_1]^{2/3}} \quad (1)$$

where  $L_1$  is the length of the laminar region, which is as yet unknown. We can also use Equation 8.42 for the mean temperature variation:

$$\frac{T_s - T_{m,t}}{T_s - T_i} = \exp\left(-\frac{\pi D L_1 \overline{h}_1}{\dot{m} c_{p1}}\right)$$

Continued...

### PROBLEM 8.29 (Cont.)

Solving for  $\bar{h}_1 L_1$ , we have

$$\begin{aligned}\bar{h}_1 L_1 &= -\frac{\dot{m} c_{p1}}{\pi D} \ln\left(\frac{T_s - T_{m,t}}{T_s - T_i}\right) = -\frac{1 \text{ kg/s} \times 1999 \text{ J/kg} \cdot \text{K}}{\pi \times 0.005 \text{ m}} \ln\left(\frac{150^\circ\text{C} - 52^\circ\text{C}}{150^\circ\text{C} - 45^\circ\text{C}}\right) \\ &= 8780 \text{ W/m} \cdot \text{K}\end{aligned}\quad (2)$$

We can solve by iterating between Equations (1) and (2). Beginning with the estimate  $\bar{Nu}_{D1} = 3.66$ , we find  $\bar{h}_1 = 3.66 \text{ k}_1/D = 105 \text{ W/m}^2 \cdot \text{K}$ . From Equation (2),  $L_1 = 84 \text{ m}$ . Then from Equation (1),  $\bar{Nu}_{D1} = 22.3$  and  $\bar{h}_1 = 639 \text{ W/m}^2 \cdot \text{K}$ . Continuing the iterations, we find  $\bar{Nu}_{D1} = 16.9$ ,  $\bar{h}_1 = 484 \text{ W/m}^2 \cdot \text{K}$ , and  $L_1 = 18.1 \text{ m}$ .

Turbulent Range. The mean temperature in the turbulent region is  $\bar{T}_{m2} = (52^\circ\text{C} + 80^\circ\text{C})/2 = 66^\circ\text{C} = 339 \text{ K}$ . The properties are  $c_{p2} = 2072 \text{ J/kg} \cdot \text{K}$ ,  $\mu_2 = 5.62 \times 10^{-2} \text{ N} \cdot \text{s/m}^2$ ,  $k_2 = 0.139 \text{ W/m} \cdot \text{K}$ ,  $Pr_2 = 834$ . Thus

$$Re_{D2} = \frac{4 \dot{m}}{\pi D \mu_2} = 4530$$

We assume the flow is fully-developed hydrodynamically and thermally and use Equation 8.62,

$$Nu_{D2} = \frac{(f/8)(Re_{D2} - 1000) Pr_2}{1 + 12.7 (f/8)^{1/2} (Pr_2^{2/3} - 1)}$$

where from Equation 8.21,

$$f = (0.790 \ln Re_{D2} - 1.64)^{-2} = (0.790 \ln(4530) - 1.64)^{-2} = 0.0398$$

Thus

$$Nu_{D2} = \frac{(0.0398/8)(4530 - 1000) 834}{1 + 12.7 (0.0398/8)^{1/2} (834^{2/3} - 1)} = 184$$

and  $h_2 = Nu_{D2} k_2 / D = 5120 \text{ W/m}^2 \cdot \text{K}$ . Then the required length  $L_2$  can be found from Equation 8.42, expressed between the transition point and the outlet,

$$\begin{aligned}\frac{T_s - T_o}{T_s - T_{m,t}} &= \exp\left(-\frac{\pi D L_2 \bar{h}_2}{\dot{m} c_{p2}}\right) \\ L_2 &= -\frac{\dot{m} c_{p2}}{\pi D \bar{h}_2} \ln\left(\frac{T_s - T_o}{T_s - T_{m,t}}\right) = -\frac{1 \text{ kg/s} \times 2072 \text{ J/kg} \cdot \text{K}}{\pi \times 0.005 \text{ m} \times 5120 \text{ W/m}^2 \cdot \text{K}} \ln\left(\frac{150^\circ\text{C} - 80^\circ\text{C}}{150^\circ\text{C} - 52^\circ\text{C}}\right) \\ &= 8.7 \text{ m}\end{aligned}$$

The total required length is  $L = L_1 + L_2 = 26.8 \text{ m}$ . <

**COMMENTS:** (1) If we had simply calculated the properties based on the mean temperature of  $\bar{T}_m = (45^\circ\text{C} + 80^\circ\text{C})/2 = 62.5^\circ\text{C} = 335.5 \text{ K}$ , we would have found  $Re_D = 3810$ . Assuming the flow to be turbulent throughout would have resulted in a higher average Nusselt number,  $\bar{Nu}_D = 159$ , and correspondingly lower total length,  $L = 11.9 \text{ m}$ . The variation of properties with temperature can be very important for some fluids such as oils. (2) If the oil were being cooled by exposure to a cooler wall, the Reynolds number could decrease from a turbulent to a laminar value. The flow would likely not completely “relaminarize,” and the heat transfer in the section for which  $Re_D < 2300$  would fall between the values calculated using laminar and turbulent Nusselt number correlations.

### PROBLEM 8.30

**KNOWN:** Diameter and length of tube, air flow rate, air temperature and pressure at the tube inlet. Surface temperature at the tube exit.

**FIND:** (a) The heat transfer rate of the problem. (b) Conditions at the tube exit for reduced tube length. (c) Conditions at the tube exit for increased air flow rate.

**SCHEMATIC:**

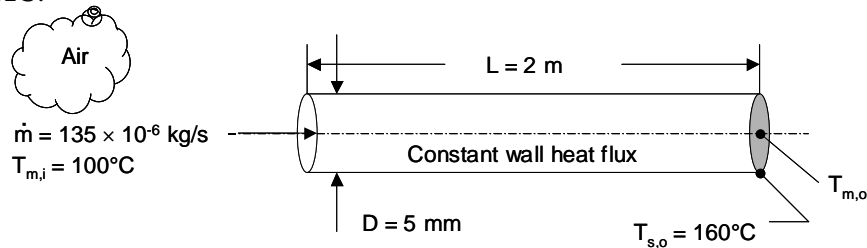

**ASSUMPTIONS:** (1) Steady-state conditions, (2) Constant properties, (3) Negligible viscous dissipation.

**PROPERTIES:** Table A.4, Air ( $\bar{T}_m \approx 400$  K,  $p = 1$  atm):  $\mu = 230.1 \times 10^{-7}$  N·s/m<sup>2</sup>,  $Pr = 0.690$ ,  $k = 0.0338$  W/m·K,  $c_p = 1014$  J/kg·K.

**ANALYSIS:** (a) We begin by calculating the Reynolds number

$$Re_D = \frac{4\dot{m}}{\pi D \mu} = \frac{4 \times 135 \times 10^{-6} \text{ kg/s}}{\pi \times 0.005 \text{ m} \times 230.1 \times 10^{-7} \text{ N} \cdot \text{s/m}^2} = 1494$$

Therefore, the flow is laminar. The hydrodynamic and thermal entrance lengths are

$$x_{fd,h} = 0.05 D Re_D = 0.05 \times 0.005 \text{ m} \times 1494 = 0.37 \text{ m}$$

$$x_{fd,t} = x_{fd,h} Pr = 0.37 \text{ m} \times 0.690 = 0.26 \text{ m}$$

Therefore, the flow is fully-developed at the tube exit. For fully-developed laminar flow with constant heat flux conditions, the Nusselt number is  $Nu_D = 4.36$ . Therefore, the local heat transfer coefficient at the tube exit is

$$h = 4.36k / D = 4.36 \times 0.0338 \text{ W/m} \cdot \text{K} / 0.005 \text{ m} = 29.47 \text{ W/m}^2 \cdot \text{K}$$

Two independent expressions for the heat flux may be written based upon application of Newton's law of cooling at the tube exit and an overall energy balance.

$$q'' = h(T_{s,o} - T_{m,o}) \quad ; \quad q'' = \frac{\dot{m}c_p(T_{m,o} - T_{m,i})}{\pi DL} \quad (1, 2)$$

Equating Eqs. (1) and (2) yields

Continued...

**PROBLEM 8.30 (Cont.)**

$$\begin{aligned}
 T_{m,o} &= \left[ hT_{s,o} + \frac{\dot{m}c_p}{\pi DL} T_{m,i} \right] / \left[ \frac{\dot{m}c_p}{\pi DL} + h \right] \\
 &= \frac{\left[ 29.47 \text{ W/m}^2 \cdot \text{K} \times 160^\circ\text{C} + \frac{135 \times 10^{-6} \text{ kg/s} \times 1014 \text{ J/kg} \cdot \text{K}}{\pi \times 0.005 \text{ m} \times 2 \text{ m}} \times 100^\circ\text{C} \right]}{\left[ \frac{135 \times 10^{-6} \text{ kg/s} \times 1014 \text{ J/kg} \cdot \text{K}}{\pi \times 0.005 \text{ m} \times 2 \text{ m}} + 29.47 \text{ W/m}^2 \cdot \text{K} \right]} \\
 &= 152.3^\circ\text{C}
 \end{aligned}$$

Hence, the heat rate is

$$q = \dot{m}c_p(T_{m,o} - T_{m,i}) = 135 \times 10^{-6} \text{ kg/s} \times 1014 \text{ J/kg} \cdot \text{K} \times 52.3^\circ\text{C} = 7.16 \text{ W} \quad <$$

(b) If  $L = 0.2 \text{ m}$ , conditions at  $x = L$  are not fully developed and the value of the heat transfer coefficient at the tube exit would exceed that of part (a).

(c) If the flow rate is increased by an order of magnitude, the Reynolds number will increase to  $Re_D = 14,940$ , and the flow will be turbulent at the tube exit. Since  $L/D = 2 \text{ m} / 0.005 \text{ m} = 400$ , the turbulent flow at the tube exit will also be fully developed. The heat transfer coefficient at the tube exit would exceed that of part (a).

**COMMENTS:** In part (b), the local heat transfer coefficient would exceed  $h = 29.47 \text{ W/m}^2$  at the tube exit and could be estimated using Fig. 8.10a. Specifically, for  $Gz^{-1} = (x/D)/(Re_D Pr) = (0.2 \text{ m} / 0.005 \text{ m}) / (1494 \times 0.690) = 0.039$ ,  $Nu_D \approx 4.6$ . Hence,  $h = 29.47 \text{ W/m}^2 \times (4.6/4.36) = 31.1 \text{ W/m}^2 \cdot \text{K}$ . In part (c), the local heat transfer coefficient would exceed  $h = 29.47 \text{ W/m}^2$  and could be evaluated using the Dittus-Boelter correlation. Specifically,  $Nu_D = 0.023 \times (14,940)^{4/5} \times 0.690^{0.4} = 43.3$ . Hence,  $h = 29.47 \text{ W/m}^2 \times (43.3/4.36) = 292.7 \text{ W/m}^2 \cdot \text{K}$ . For  $T_{s,o}$  to remain the same, the heat rate associated with either part (b) or part (c) would have to exceed that of part (a).

### PROBLEM 8.31

**KNOWN:** Thermal conductivity and inner and outer diameters of plastic pipe. Volumetric flow rate and inlet and outlet temperatures of air flow through pipe. Convection coefficient and temperature of water.

**FIND:** Pipe length and fan power requirement.

**SCHEMATIC:**

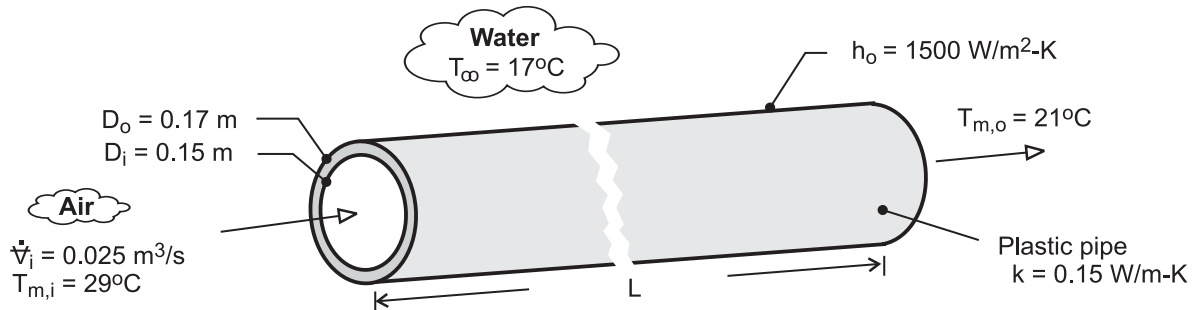

**ASSUMPTIONS:** (1) Steady-state, (2) Negligible heat transfer from air in vertical legs of pipe, (3) Ideal gas with negligible viscous dissipation and pressure variation, (4) Smooth interior surface, (5) Constant properties.

**PROPERTIES:** Table A-4, Air ( $T_{m,i} = 29^\circ\text{C}$ ):  $\rho_1 = 1.155 \text{ kg/m}^3$ . Air ( $\bar{T}_m = 25^\circ\text{C}$ ):  $c_p = 1007 \text{ J/kg}\cdot\text{K}$ ,  $\mu = 183.6 \times 10^{-7} \text{ N}\cdot\text{s/m}^2$ ,  $k_a = 0.0261 \text{ W/m}\cdot\text{K}$ ,  $\text{Pr} = 0.707$ .

**ANALYSIS:** From Eq. (8.45a)

$$\frac{T_\infty - T_{m,o}}{T_\infty - T_{m,i}} = \exp\left(-\frac{\bar{U}A_s}{\dot{m}c_p}\right)$$

where, from Eqs. (3.34) and (3.35),  $(\bar{U}A_s)^{-1} = R_{\text{tot}} = \frac{1}{h_i\pi D_i L} + \frac{\ln(D_o/D_i)}{2\pi Lk} + \frac{1}{h_o\pi D_o L}$

With  $\dot{m} = \rho_1 \dot{V}_i = 0.0289 \text{ kg/s}$  and  $\text{Re}_D = 4\dot{m}/\pi D_i \mu = 13,350$ , flow in the pipe is turbulent. Assuming fully developed flow throughout the pipe, and from Eq. (8.60),

$$\bar{h}_i = \frac{k_a}{D_i} 0.023 \text{Re}_D^{4/5} \text{Pr}^{0.3} = \frac{0.0261 \text{ W/m}\cdot\text{K} \times 0.023}{0.15 \text{ m}} (13,350)^{4/5} (0.707)^{0.3} = 7.20 \text{ W/m}^2 \cdot \text{K}$$

$$(\bar{U}A_s)^{-1} = \frac{1}{L} \left( \frac{1}{7.21 \text{ W/m}^2 \cdot \text{K} \times \pi \times 0.15 \text{ m}} + \frac{\ln(0.17/0.15)}{2\pi \times 0.15 \text{ W/m}\cdot\text{K}} + \frac{1}{1500 \text{ W/m}^2 \cdot \text{K} \times \pi \times 0.17 \text{ m}} \right)$$

$$\bar{U}A_s = \frac{L}{(0.294 + 0.133 + 0.001)} = 2.335 L \text{ W/K}$$

$$\frac{T_\infty - T_{m,o}}{T_\infty - T_{m,i}} = \frac{17 - 21}{17 - 29} = 0.333 = \exp\left(-\frac{2.335 L}{0.0289 \text{ kg/s} \times 1007 \text{ J/kg}\cdot\text{K}}\right) = \exp(-0.0802L)$$

$$L = -\frac{\ln(0.333)}{0.0802} = 13.7 \text{ m} \quad \leftarrow$$

From Eqs. (8.22a) and (8.22b) and with  $u_{m,i} = \dot{V}_i / (\pi D_i^2 / 4) = 1.415 \text{ m/s}$ , the fan power is

$$P = (\Delta p) \dot{V} \approx f \frac{\rho_1 u_{m,i}^2}{2D_i} L \dot{V}_i = 0.0291 \frac{1.155 \text{ kg/m}^3 (1.415 \text{ m/s})^2}{2(0.15 \text{ m})} 13.7 \text{ m} \times 0.025 \text{ m}^3/\text{s} = 0.077 \text{ W} \quad \leftarrow$$

where  $f = (0.790 \ln \text{Re}_D - 1.64)^{-2} = 0.0291$  from Eq. (8.21).

**COMMENTS:** (1) With  $L/D_i = 91$ , the assumption of fully developed flow throughout the pipe is justified. (2) The fan power requirement is small, and the process is economical. (3) The resistance to heat transfer associated with convection at the outer surface is negligible.



### PROBLEM 8.32

**KNOWN:** Inlet temperature, flow rate and properties of hot fluid. Initial temperature, volume and properties of pharmaceutical. Heat transfer coefficient at outer surface and dimensions of coil.

**FIND:** (a) Expressions for  $T_c(t)$  and  $T_{h,o}(t)$ , (b) Plots of  $T_c(t)$  and  $T_{h,o}(t)$  for prescribed conditions. Effect of flow rate on time for pharmaceutical to reach a prescribed temperature.

**SCHEMATIC:**

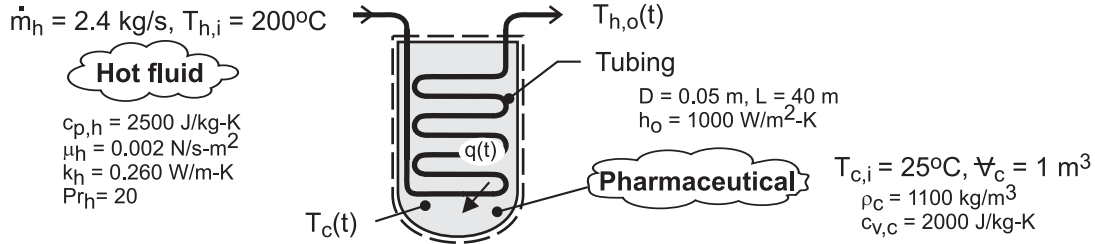

**ASSUMPTIONS:** (1) Constant properties, (2) Negligible heat loss from vessel to surroundings, (3) Pharmaceutical is isothermal, (4) Negligible work due to stirring, (5) Negligible thermal energy generation (or absorption) due to chemical reactions associated with the batch process, (6) Hot fluid is an incompressible liquid with negligible viscous dissipation, (7) Negligible tube wall conduction resistance.

**ANALYSIS:** (a) Performing an energy balance for a control surface about the stirred liquid, it follows that

$$\frac{dU_c}{dt} = \frac{d}{dt}(\rho_c V_c c_{v,c} T_c) = \rho_c V_c c_{v,c} \frac{dT_c}{dt} = q(t) \quad (1)$$

where,  $q(t) = \dot{m}_h c_{p,h} (T_{h,i} - T_{h,o}) \quad (2)$

or,  $q(t) = UA_s \Delta T_{lm} \quad (3a)$

where

$$\Delta T_{lm} = \frac{(T_{h,i} - T_c) - (T_{h,o} - T_c)}{\ln\left(\frac{T_{h,i} - T_c}{T_{h,o} - T_c}\right)} = \frac{(T_{h,i} - T_{h,o})}{\ln\left(\frac{T_{h,i} - T_c}{T_{h,o} - T_c}\right)} \quad (3b)$$

Substituting (3b) into (3a) and equating to (2),

$$\dot{m}_h c_{p,h} (T_{h,i} - T_{h,o}) = UA_s \frac{(T_{h,i} - T_{h,o})}{\ln\left(\frac{T_{h,i} - T_c}{T_{h,o} - T_c}\right)}$$

Hence,  $\ln\left(\frac{T_{h,i} - T_c}{T_{h,o} - T_c}\right) = \frac{UA_s}{\dot{m}_h c_{p,h}}$

or,  $T_{h,o}(t) = T_c + (T_{h,i} - T_c) \exp(-UA_s / \dot{m}_h c_{p,h}) \quad (4) <$

Substituting Eqs. (2) and (4) into Eq. (1),

Continued ...

**PROBLEM 8.32 (Cont.)**

$$\rho_c V_c c_{v,c} \frac{dT_c}{dt} = \dot{m}_h c_{p,h} \left[ T_{h,i} - T_c - (T_{h,i} - T_c) \exp(-UA_s / \dot{m}_h c_{p,h}) \right]$$

$$\frac{dT_c}{dt} = \frac{\dot{m}_h c_{p,h} (T_{h,i} - T_c)}{\rho_c V_c c_{v,c}} \left[ 1 - \exp(-UA_s / \dot{m}_h c_{p,h}) \right]$$

$$-\int_{T_{c,i}}^{T_c(t)} \frac{dT_c}{(T_c - T_{h,i})} = \frac{\dot{m}_h c_{p,h}}{\rho_c V_c c_{v,c}} \left[ 1 - \exp(-UA_s / \dot{m}_h c_{p,h}) \right] \int_0^t dt$$

$$-\ln \left( \frac{T_c - T_{h,i}}{T_{c,i} - T_{h,i}} \right) = \frac{\dot{m}_h c_{p,h}}{\rho_c V_c c_{v,c}} \left[ 1 - \exp(-UA_s / \dot{m}_h c_{p,h}) \right] t$$

$$T_c(t) = T_{h,i} - (T_{h,i} - T_{c,i}) \exp \left\{ - \frac{\dot{m}_h c_{p,h} \left[ 1 - \exp(-UA_s / \dot{m}_h c_{p,h}) \right] t}{\rho_c V_c c_{v,c}} \right\} \quad (5) <$$

Eq. (5) may be used to determine  $T_c(t)$  and the result used with (4) to determine  $T_{h,o}(t)$ .

(b) To evaluate the temperature histories, the overall heat transfer coefficient,  $U = (h_o^{-1} + h_i^{-1})^{-1}$ , must first be determined. With  $Re_D = 4 \dot{m} / \pi D \mu = 4 \times 2.4 \text{ kg/s} / \pi (0.05 \text{ m}) 0.002 \text{ N} \cdot \text{s/m}^2 = 30,600$ , the flow is turbulent and

$$h_i = \frac{k}{D} Nu_D = \frac{0.260 \text{ W/m} \cdot \text{K}}{0.05 \text{ m}} \left[ 0.023 (30,600)^{4/5} (20)^{0.3} \right] = 1140 \text{ W/m}^2 \cdot \text{K}$$

Hence,  $U = \left[ (1000)^{-1} + (1140)^{-1} \right]^{-1} \text{ W/m}^2 \cdot \text{K} = 532 \text{ W/m}^2 \cdot \text{K}$ . As shown below, the temperature of the pharmaceuticals increases with time due to heat transfer from the hot fluid, approaching the inlet temperature of the hot fluid (and its maximum possible temperature of 200°C) at  $t = 3600\text{s}$ .

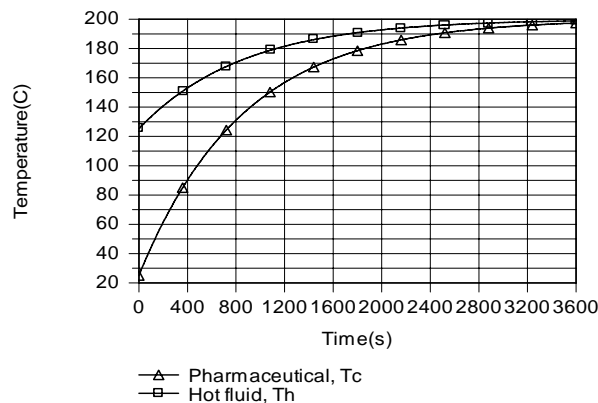

Continued ...

### PROBLEM 8.32 (Cont.)

With increasing  $T_c$ , the rate of heat transfer from the hot fluid decreases (from  $4.49 \times 10^5$  W at  $t = 0$  to 6760 W at 3600s), in which case  $T_{h,o}$  increases (from  $125.2^\circ\text{C}$  at  $t = 0$  to  $198.9^\circ\text{C}$  at 3600s). The time required for the pharmaceuticals to reach a temperature of  $T_c = 160^\circ\text{C}$  is

$$t_c = 1266\text{s}$$

&lt;

With increasing  $\dot{m}_h$ , the overall heat transfer coefficient increases due to increasing  $h_i$  and the hot fluid maintains a higher temperature as it flows through the tube. Both effects enhance heat transfer to the pharmaceutical, thereby reducing the time to reach  $160^\circ\text{C}$  from 2178s for  $\dot{m}_h = 1$  kg/s to 906s at 5 kg/s.

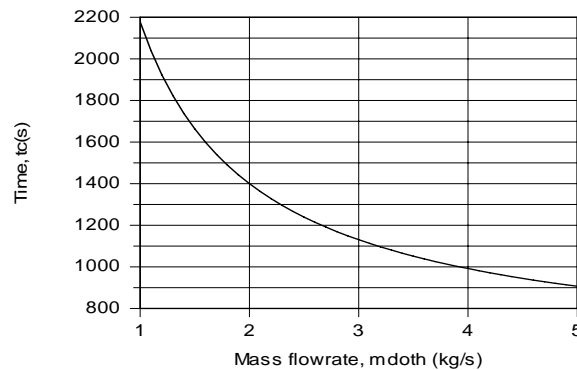

For  $1 \leq \dot{m}_h \leq 5$  kg/s,  $12,700 \leq \text{Re}_D \leq 63,700$  and  $565 \leq h_i \leq 2050$  W/m<sup>2</sup>·K.

**COMMENTS:** (1) Although design changes involving the length and diameter of the coil can be used to alter the heating rate, process control parameters are limited to  $T_{h,i}$  and  $\dot{m}_h$ . (2) Coiling the tube can increase the inside heat transfer coefficient, as will be seen in Section 8.7.

### PROBLEM 8.33

**KNOWN:** Diameter and surface temperature of ten tubes in an ice bath. Inlet temperature and flowrate per tube. Volume ( $\nabla$ ) of container and initial volume fraction,  $f_{v,i}$ , of ice.

**FIND:** (a) Tube length required to achieve a prescribed air outlet temperature  $T_{m,o}$  and time to completely melt the ice, (b) Effect of mass flowrate on  $T_{m,o}$  and suitable design and operating conditions.

**SCHEMATIC:**

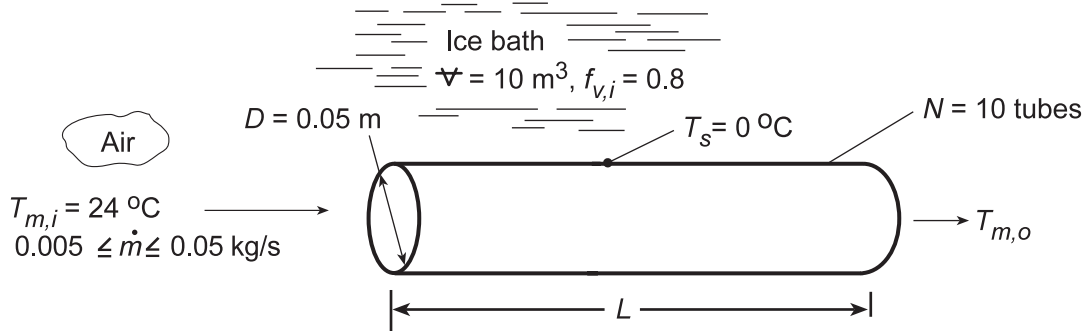

**ASSUMPTIONS:** (1) Steady-state, (2) Ideal gas with negligible viscous dissipation and pressure variation, (3) Constant properties, (4) Fully developed flow throughout each tube, (5) Negligible tube wall thermal resistance.

**PROPERTIES:** Table A.4, air (assume  $\bar{T}_m = 292$  K):  $c_p = 1007$  J/kg·K,  $\mu = 180.6 \times 10^{-7}$  N·s/m<sup>2</sup>,  $k = 0.0257$  W/m·K,  $Pr = 0.709$ ; Ice:  $\rho = 920$  kg/m<sup>3</sup>,  $h_{sf} = 3.34 \times 10^5$  J/kg.

**ANALYSIS:** (a) With  $Re_D = 4 \dot{m} / \pi D \mu = 4(0.01 \text{ kg/s}) / \pi(0.05 \text{ m})180.6 \times 10^{-7} \text{ N·s/m}^2 = 14,100$  for  $\dot{m} = 0.01$  kg/s, the flow is turbulent, and from Eq. 8.60,

$$\overline{Nu}_D = Nu_D = 0.023 Re_D^{0.8} Pr^{0.3} = 0.023(14,100)^{0.8} (0.709)^{0.3} = 43.3$$

$$\bar{h} = \overline{Nu}_D (k/D) = 43.3(0.0257 \text{ W/m} \cdot \text{K} / 0.05 \text{ m}) = 22.2 \text{ W/m}^2 \cdot \text{K}$$

With  $T_{m,o} = 14^\circ\text{C}$ , the tube length may be obtained from Eq. 8.41b,

$$\frac{T_s - T_{m,o}}{T_s - T_{m,i}} = \frac{-14}{-24} = \exp\left(-\frac{\pi DL \bar{h}}{\dot{m} c_p}\right) = \exp\left[-\frac{\pi(0.05 \text{ m})(22.2 \text{ W/m}^2 \cdot \text{K})L}{0.01 \text{ kg/s}(1007 \text{ J/kg} \cdot \text{K})}\right]$$

$$L = 1.56 \text{ m} \quad \leftarrow$$

The time required to completely melt the ice may be obtained from an energy balance of the form,

$$(-q)t = f_{v,i} \nabla (\rho h_{sf})$$

where  $q = N \dot{m} c_p (T_{m,i} - T_{m,o}) = 10(0.01 \text{ kg/s})1007 \text{ J/kg} \cdot \text{K}(10 \text{ K}) = 1007 \text{ W}$ . Hence,

$$t = \frac{0.8(10 \text{ m}^3)(920 \text{ kg/m}^3)3.34 \times 10^5 \text{ J/kg}}{1007 \text{ W}} = 2.44 \times 10^6 \text{ s} = 28.3 \text{ days} \quad \leftarrow$$

(b) Using the appropriate IHT Correlations and Properties Tool Pads, the following results were obtained.

Continued...

### PROBLEM 8.33 (Cont.)

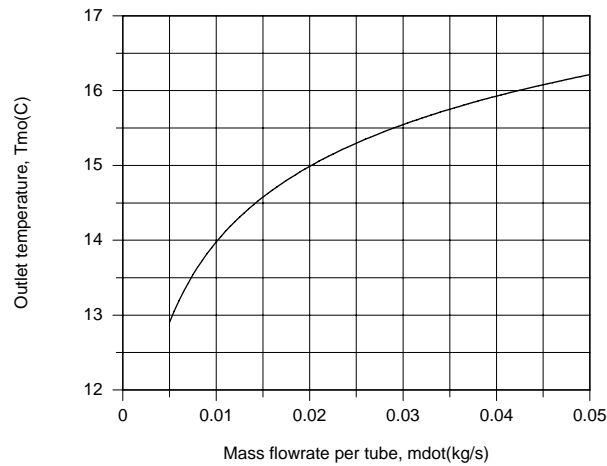

Although heat extraction from the air passing through each tube increases with increasing flowrate, the increase is not in proportion to the change in  $\dot{m}$  and the temperature difference ( $T_{m,i} - T_{m,o}$ ) decreases. If 0.05 kg/s of air is routed through a single tube, the outlet temperature of  $T_{m,o} = 16.2^\circ\text{C}$  slightly exceeds the desired value of  $16^\circ\text{C}$ . The prescribed value could be achieved by slightly increasing the tube length. However, in the interest of reducing pressure drop requirements, it would be better to operate at a lower flowrate per tube. If, for example, air is routed through four of the tubes at 0.01 kg/s per tube and the discharge is mixed with 0.01 kg/s of the available air at  $24^\circ\text{C}$ , the desired result would be achieved.

**COMMENTS:** Since the flow is turbulent and  $L/D = 31$ , the assumption of fully developed flow throughout a tube is marginal and the foregoing analysis overestimates the discharge temperature.

## PROBLEM 8.34

**KNOWN:** Initial food temperature and mass flow rate. Length of heating and cooling sections in a food sterilizer. Diameter of sterilizer tube. Time-at-temperature constraint, and constraint on local maximum food temperature.

**FIND:** (a) Heat flux in the heating section. (b) Maximum local product temperature and its location. (c) Minimum required sterilizing section length. (d) Sketch of the axial distributions of the mean, surface, and centerline food temperatures from entrance to exit of sterilizer.

**SCHEMATIC:**

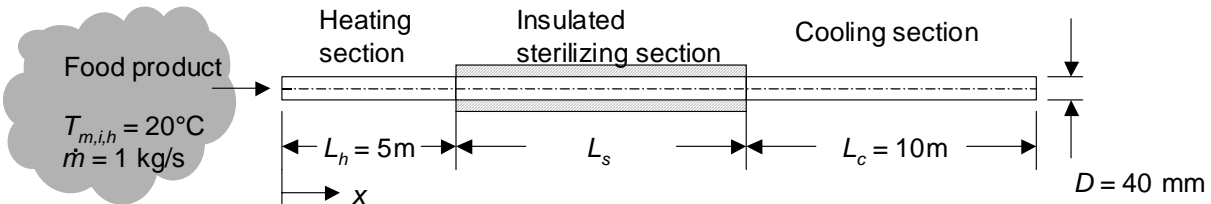

**ASSUMPTIONS:** (1) Steady-state conditions, (2) Constant properties, (3) Negligible viscous dissipation.

**PROPERTIES:** Table A.6, Water ( $\bar{T}_m = 330 \text{ K}$ ,  $p = 1 \text{ atm}$ ):  $\mu = 489 \times 10^{-6} \text{ N}\cdot\text{s}/\text{m}^2$ ,  $Pr = 3.15$ ,  $k = 0.65 \text{ W}/\text{m}\cdot\text{K}$ ,  $c_p = 4184 \text{ J}/\text{kg}\cdot\text{K}$ ,  $\rho = 984 \text{ kg}/\text{m}^3$ .

**ANALYSIS:** (a) An energy balance applied to the heating section yields

$$q = q''A = q''\pi DL_h = \dot{m}c_p(T_{m,o,h} - T_{m,i,h})$$

which may be rearranged to provide the expression

$$q'' = \frac{\dot{m}c_p(T_{m,o,h} - T_{m,i,h})}{\pi DL_h} = \frac{1 \text{ kg/s} \times 4184 \text{ J}/\text{kg}\cdot\text{K} \times (90 - 20)^\circ\text{C}}{\pi \times 0.04 \text{ m} \times 5 \text{ m}} = 466,000 \text{ W}/\text{m}^2 = 466 \text{ kW}/\text{m}^2 <$$

(b) The maximum local product temperature occurs at the tube wall at the end of the heating section. The Reynolds number is

$$Re_D = \frac{4\dot{m}}{\pi D\mu} = \frac{4 \times 1 \text{ kg/s}}{\pi \times 0.04 \text{ m} \times 489 \times 10^{-6} \text{ N}\cdot\text{s}/\text{m}^2} = 65,090$$

Hence, the flow is turbulent. Since  $L_h/D = 5 \text{ m}/0.04 \text{ m} = 125$ , the flow is fully-developed. Using the Dittus-Boelter correlation,

$$h = \frac{k}{D} \left[ 0.023 Re_D^{4/5} Pr^{0.4} \right] = \frac{0.65 \text{ W}/\text{m}\cdot\text{K}}{0.04 \text{ m}} \left[ 0.023 \times 65,090^{4/5} \times 3.15^{0.4} \right] = 4190 \text{ W}/\text{m}^2 \cdot \text{K}$$

From Newton's law of cooling,

$$T_s(x = L_h = 5 \text{ m}) = T_{m,o,h} + \frac{q''}{h} = 90^\circ\text{C} + \frac{466,000 \text{ W}/\text{m}^2}{4190 \text{ W}/\text{m}^2 \cdot \text{K}} = 201^\circ\text{C} <$$

Continued...

### PROBLEM 8.34 (Cont.)

The second constraint is satisfied. <

(c) The minimum length of the sterilizing section is

$$L_s = u_m t_s = \frac{4\dot{m}}{\rho\pi D^2} t_s = \frac{4 \times 1 \text{ kg/s}}{984 \text{ kg/m}^3 \times \pi \times (0.04 \text{ m})^2} \times 10 \text{ s} = 8.1\text{m} <$$

(d) The axial distributions of the mean, surface, and centerline temperatures are shown below.

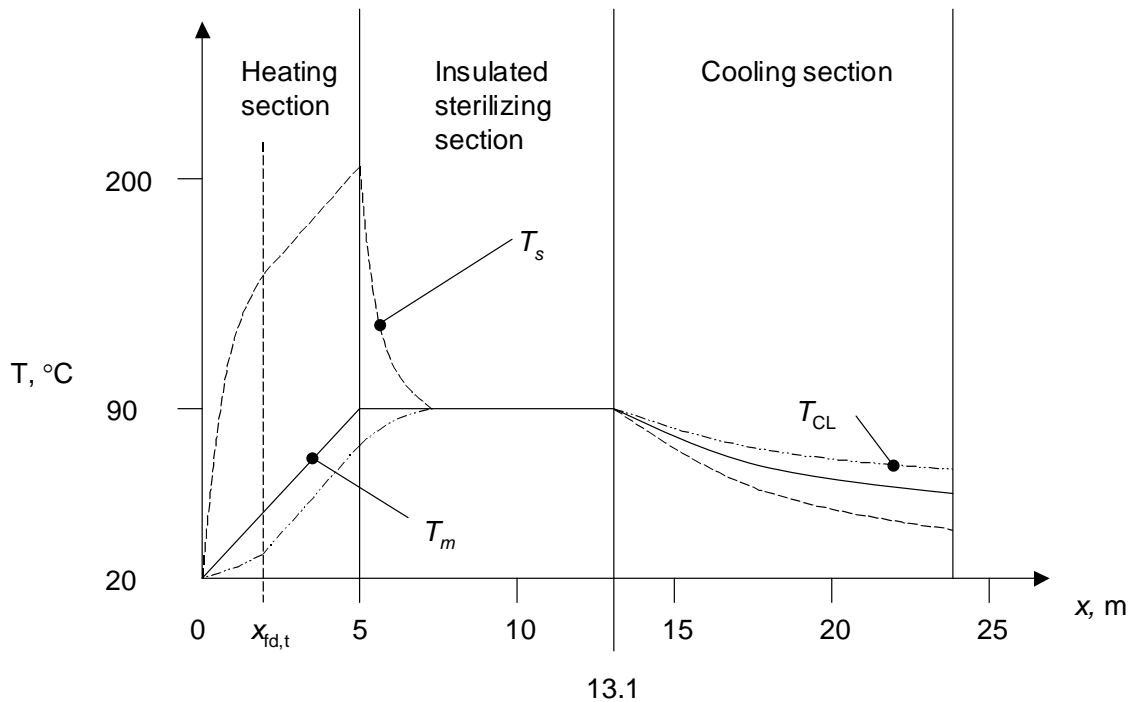

Important features of the temperature distribution are as follows.

$0 \leq x \leq x_{fd,t}$ : Near the tube entrance, the heat transfer coefficient is theoretically infinite, and all three temperatures are nearly the same value.

$x_{fd,t} \leq x \leq L_h$ : The flow is fully-developed; the shape of the radial temperature distribution does not change down the tube length. Therefore, the three temperature distributions are parallel.

$L_h \leq x \leq L_h + L_s$ : The heat transfer coefficient is zero. However, temperature differences exist in the fluid, with warm temperatures adjacent to the tube wall and cool temperatures near the centerline of the tube. As the flow progresses down the insulated sterilizing section, the temperatures equilibrate by way of diffusion and turbulent mixing. The equilibration takes place over a distance approximately equal to  $x_{fd,t}$ .

Continued...

### PROBLEM 8.34 (Cont.)

$L_h + L_s \leq x \leq L_h + L_s + L_c$ : The fluid is cooled. Hence, the warmest temperature fluid is at the centerline, and the coolest fluid is adjacent to the tube wall. Since the fluid is cooled by exposure of the tube to the environment, the cooling rate is expected to be smaller than the heating rate in the heating section. Hence, the radial temperature differences in the cooling section are smaller than the radial temperature differences in the heating section.

**COMMENTS:** (1) The velocity of the fluid at the centerline exceeds velocities at any other radial location. Hence, the fluid at the centerline of the tube will not satisfy the time-at-temperature criterion. Therefore, use of a coiled tube or other heat transfer enhancement devices (Section 8.7) would be appropriate in this application. (2) The insulation thickness in the sterilizing section should be much greater than the critical insulation thickness.



### PROBLEM 8.35

**KNOWN:** Flow rate, inlet temperature and desired outlet temperature of water passing through a tube of prescribed diameter and surface temperature.

**FIND:** (a) Required tube length,  $L$ , for prescribed conditions, (b) Required length using tube diameters over the range  $30 \leq D \leq 50$  mm with flow rates  $\dot{m} = 1, 2$  and  $3$  kg/s; represent this design information graphically, and (c) Pressure gradient as a function of tube diameter for the three flow rates assuming the tube wall is smooth.

**SCHEMATIC:**

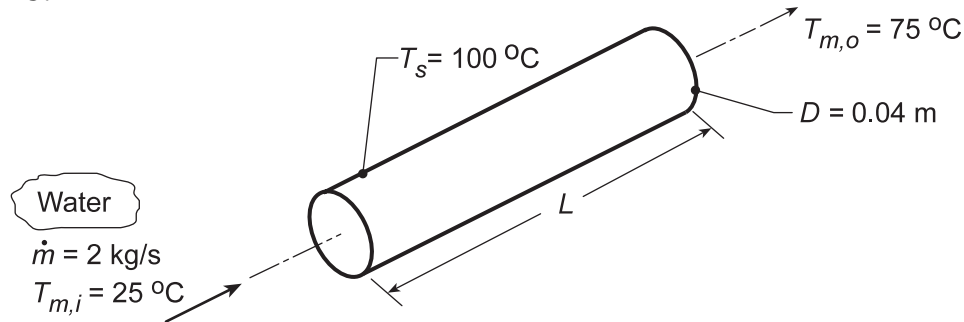

**ASSUMPTIONS:** (1) Steady-state conditions, (2) Incompressible liquid with negligible viscous dissipation, (3) Constant properties.

**PROPERTIES:** Table A.6, Water ( $\bar{T}_m = 323$  K):  $c_p = 4181$  J/kg·K,  $\mu = 547 \times 10^{-6}$  N·s/m<sup>2</sup>,  $k = 0.643$  W/m·K,  $Pr = 3.56$ .

**ANALYSIS:** (a) From Eq. 8.6, the Reynolds number is

$$Re_D = \frac{4\dot{m}}{\pi D \mu} = \frac{4 \times 2 \text{ kg/s}}{\pi (0.04 \text{ m}) 547 \times 10^{-6} \text{ N} \cdot \text{s/m}^2} = 1.16 \times 10^5. \quad (1)$$

Hence the flow is turbulent, and assuming fully developed conditions throughout the tube, it follows from the Dittus-Boelter correlation, Eq. 8.60,

$$\bar{h} = \frac{k}{D} 0.023 Re_D^{4/5} Pr^{0.4} = \frac{0.643 \text{ W/m} \cdot \text{K}}{0.04 \text{ m}} 0.023 (1.16 \times 10^5)^{4/5} (3.56)^{0.4} = 6919 \text{ W/m}^2 \cdot \text{K} \quad (2)$$

From Eq. 8.41a, we then obtain

$$L = \frac{-\dot{m} c_p \ln(\Delta T_o / \Delta T_i)}{\pi D \bar{h}} = - \frac{2 \text{ kg/s} (4181 \text{ J/kg} \cdot \text{K}) \ln(25^\circ \text{C} / 75^\circ \text{C})}{\pi (0.04 \text{ m}) 6919 \text{ W/m}^2 \cdot \text{K}} = 10.6 \text{ m}. \quad <$$

(b) Using the *IHT Correlations Tool, Internal Flow*, for fully developed *Turbulent Flow*, along with appropriate energy balance and rate equations, the required length  $L$  as a function of flow rate is computed and plotted on the right.

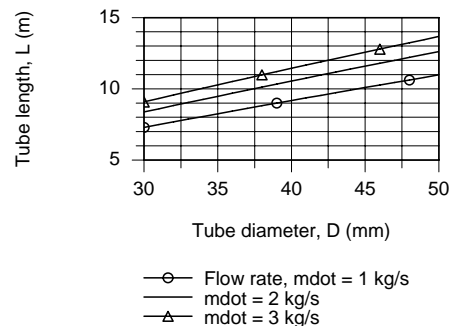

Continued...

### PROBLEM 8.35 (Cont.)

(c) From Eq. 8.22a the pressure drop is

$$\frac{\Delta p}{\Delta x} = f \frac{\rho u_m^2}{2D} \quad (4)$$

The friction factor,  $f$ , for the smooth surface condition, Eq. 8.21 with  $3000 \leq Re_D \leq 5 \times 10^6$ , is

$$f = (0.790 \ln(Re_D) - 1.64)^{-2} \quad (5)$$

Using IHT with these equations and Eq. (1), the pressure gradient as a function of diameter for the selected flow rates is computed and plotted on the right.

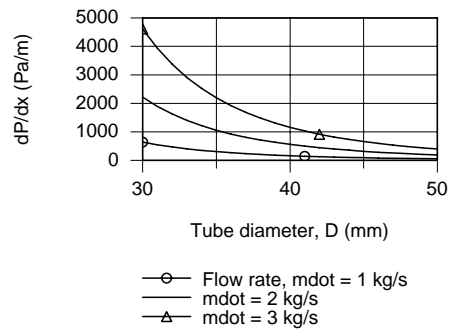

**COMMENTS:** (1) Since  $L/D = (10.6/0.040) = 265$ , the assumption of fully developed conditions throughout is justified.

(2) The IHT Workspace used to generate the graphical results are shown below.

```

// Rate Equation Tool - Tube Flow with Constant Surface Temperature:
/* For flow through a tube with a uniform wall temperature, Fig 8.7b, the
overall energy balance and heat rate equations are */
q = mdot*cp*(Tmo - Tmi) // Heat rate, W; Eq 8.34
(Ts - Tmo) / (Ts - Tmi) = exp ( - P * L * hDbar / (mdot * cp)) // Eq 8.41b
// where the fluid and constant tube wall temperatures are
Ts = 100 + 273 // Tube wall temperature, K
Tmi = 25 + 273 // Inlet mean fluid temperature, K
Tmo = 75 + 273 // Outlet mean fluid temperature, K
// The tube parameters are
P = pi * D // Perimeter, m
Ac = pi * (D^2) / 4 // Cross sectional area, m^2
D = 0.040 // Tube diameter, m
D_mm = D * 1000
// The tube mass flow rate and fluid thermophysical properties are
mdot = rho * um * Ac
mdot = 1 // Mass flow rate, kg/s

// Correlation Tool - Internal Flow, Fully Developed Turbulent Flow (Assumed):
NuDbar = NuD_bar_IF_T_FD(ReD,Pr,n) // Eq 8.60
n = 0.4 // n = 0.4 or 0.3 for Ts>Tm or Ts<Tm
NuDbar = hDbar * D / k
ReD = um * D / nu
/* Evaluate properties at the fluid average mean temperature, Tmbar. */
Tmbar = Tfluid_avg (Tmi,Tmo)

// Properties Tool - Water:
// Water property functions :T dependence, From Table A.6
// Units: T(K), p(bars);
x = 0 // Quality (0=sat liquid or 1=sat vapor)
rho = rho_Tx("Water",Tmbar,x) // Density, kg/m^3
cp = cp_Tx("Water",Tmbar,x) // Specific heat, J/kg-K
nu = nu_Tx("Water",Tmbar,x) // Kinematic viscosity, m^2/s
k = k_Tx("Water",Tmbar,x) // Thermal conductivity, W/m-K
Pr = Pr_Tx("Water",Tmbar,x) // Prandtl number

// Pressure Gradient, Equations 8.21, 8.22a:
dPdx = f * rho * um^2 / ( 2 * D )
f = ( 0.790 * ln (ReD) - 1.64 ) ^ -2
    
```

### PROBLEM 8.36

**KNOWN:** Diameters and thermal conductivity of steel pipe. Temperature and velocity of water flow in pipe. Temperature and velocity of air in cross flow over pipe. Cost of producing hot water.

**FIND:** Daily cost of heat loss per unit length of pipe.

**SCHEMATIC:**

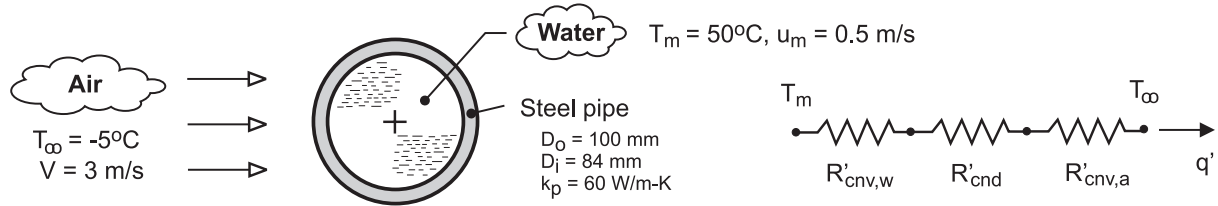

**ASSUMPTIONS:** (1) Steady state, (2) Constant properties, (3) Negligible radiation from outer surface, (4) Fully-developed flow in pipe.

**PROPERTIES:** Table A-4, air ( $p = 1 \text{ atm}$ ,  $T_f \approx 300 \text{ K}$ ):  $k_a = 0.0263 \text{ W/m}\cdot\text{K}$ ,  $\nu_a = 15.89 \times 10^{-6} \text{ m}^2/\text{s}$ ,  $\text{Pr}_a = 0.707$ . Table A-6, water ( $T_m = 323 \text{ K}$ ):  $\rho_w = 988 \text{ kg/m}^3$ ,  $\mu_w = 548 \times 10^{-6} \text{ N}\cdot\text{s/m}^2$ ,  $k_w = 0.643 \text{ W/m}\cdot\text{K}$ ,  $\text{Pr}_w = 3.56$ .

**ANALYSIS:** The heat loss per unit length of pipe is

$$q' = \frac{T_m - T_\infty}{R'_{\text{cnv},w} + R'_{\text{cnd}} + R'_{\text{cnv},a}} = \frac{T_m - T_\infty}{(h_w \pi D_i)^{-1} + \frac{\ln(D_o/D_i)}{2\pi k_p} + (h_a \pi D_o)^{-1}}$$

With  $\text{Re}_{D,w} = \rho_w u_m D_i / \mu_w = 988 \text{ kg/m}^3 \times 0.5 \text{ m/s} \times 0.084 \text{ m} / 548 \times 10^{-6} \text{ N}\cdot\text{s/m}^2 = 75,700$ , flow is turbulent, and for fully developed conditions, the Dittus-Boelter correlation yields

$$h_w = \frac{k_w}{D_i} 0.023 \text{Re}_{D,w}^{0.8} \text{Pr}_w^{0.3} = 0.023 \frac{0.643 \text{ W/m}\cdot\text{K}}{0.084 \text{ m}} (75,700)^{0.8} (3.56)^{0.3} = 2060 \text{ W/m}^2 \cdot \text{K}$$

With  $\text{Re}_{D,a} = VD_o / \nu_a = 3 \text{ m/s} \times (0.1 \text{ m}) / 15.89 \times 10^{-6} \text{ m}^2/\text{s} = 18,880$ , the Churchill-Bernstein correlation yields

$$h_a = \bar{h} = \frac{k_a}{D_o} \left\{ 0.3 + \frac{0.62 \text{Re}_{D,a}^{1/2} \text{Pr}_a^{1/3}}{\left[ 1 + (0.4/\text{Pr}_a)^{2/3} \right]^{1/4}} \left[ 1 + \left( \frac{\text{Re}_{D,w}}{282,000} \right)^{5/8} \right]^{4/5} \right\} = 20.1 \text{ W/m}^2 \cdot \text{K}$$

Hence,

$$q' = \frac{50^\circ\text{C} - (-5^\circ\text{C})}{\left( 1.84 \times 10^{-3} + 0.46 \times 10^{-3} + 158.36 \times 10^{-3} \right) \text{ K/W}} = 342 \text{ W/m} = 0.342 \text{ kW/m}$$

The daily energy loss is then  $Q' = 0.346 \text{ kW/m} \times 24 \text{ h/d} = 8.22 \text{ kW}\cdot\text{h/d}\cdot\text{m}$

and the associated cost is  $C' = (8.22 \text{ kW}\cdot\text{h/d}\cdot\text{m})(\$0.05/\text{kW}\cdot\text{h}) = \$0.411/\text{m}\cdot\text{d} <$

**COMMENTS:** Because  $R'_{\text{cnv},a} \gg R'_{\text{cnv},w}$ , the convection resistance for the water side of the pipe could have been neglected, with negligible error. The implication is that the temperature of the pipe's inner surface closely approximates that of the water. If  $R'_{\text{cnv},w}$  is neglected, the heat loss is

$$q' = 346 \text{ W/m}.$$

### PROBLEM 8.37

**KNOWN:** Inner and outer diameter of a steel pipe insulated on the outside and experiencing uniform heat generation. Flow rate and inlet temperature of water flowing through the pipe.

**FIND:** (a) Pipe length required to achieve desired outlet temperature, (b) Location and value of maximum pipe temperature.

**SCHEMATIC:**

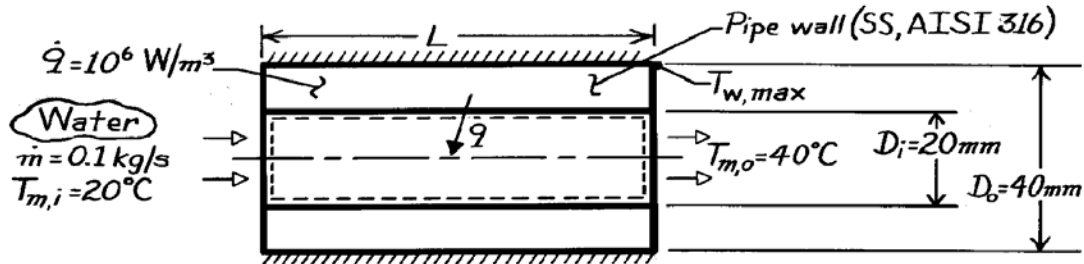

**ASSUMPTIONS:** (1) Steady-state conditions, (2) Constant properties, (3) Incompressible liquid with negligible viscous dissipation, (4) One-dimensional radial conduction in pipe wall, (5) Outer surface is adiabatic.

**PROPERTIES:** Table A-1, Stainless steel 316 ( $T \approx 400\text{K}$ ):  $k = 15 \text{ W/m}\cdot\text{K}$ ; Table A-6, Water ( $\bar{T}_m = 303\text{K}$ ):  $c_p = 4178 \text{ J/kg}\cdot\text{K}$ ,  $k = 0.617 \text{ W/m}\cdot\text{K}$ ,  $\mu = 803 \times 10^{-6} \text{ N}\cdot\text{s/m}^2$ ,  $\text{Pr} = 5.45$ .

**ANALYSIS:** (a) Performing an energy balance for a control volume about the inner tube, it follows that

$$\dot{m} c_p (T_{m,o} - T_{m,i}) = \dot{q} = \dot{q} (\pi/4) (D_o^2 - D_i^2) L$$

$$L = \frac{\dot{m} c_p (T_{m,o} - T_{m,i})}{\dot{q} (\pi/4) (D_o^2 - D_i^2)} = \frac{(0.1 \text{ kg/s}) 4178 (\text{J/kg}\cdot\text{K}) 20^\circ\text{C}}{10^6 \text{ W/m}^3 (\pi/4) [(0.04\text{m})^2 - (0.02\text{m})^2]}$$

$$L = 8.87\text{m.} \quad \leftarrow$$

(b) The maximum wall temperature exists at the pipe exit ( $x = L$ ) and the insulated surface ( $r = r_o$ ). From Eq. 3.56, the radial temperature distribution in the wall is of the form

$$T(r) = -\frac{\dot{q}}{4k} r^2 + C_1 \ln r + C_2.$$

Considering the boundary conditions;

$$r = r_o: \left. \frac{dT}{dr} \right|_{r=r_o} = 0 = -\frac{\dot{q}}{2k} r_o + \frac{C_1}{r_o} \quad C_1 = \frac{\dot{q} r_o^2}{2k}$$

Continued ...

**PROBLEM 8.37 (Cont.)**

$$r = r_i : \quad T(r_i) = T_s = -\frac{\dot{q}}{4k} r_i^2 + \frac{\dot{q} r_o^2}{2k} \ln r_i + C_2 \quad C_2 = \frac{\dot{q}}{4k} r_i^2 - \frac{\dot{q} r_o^2}{2k} \ln r_i + T_s.$$

The temperature distribution and the maximum wall temperature ( $r = r_o$ ) are

$$T(r) = -\frac{\dot{q}}{4k} (r^2 - r_i^2) + \frac{\dot{q} r_o^2}{2k} \ln \frac{r}{r_i} + T_s$$

$$T_{w,\max} = T(r_o) = -\frac{\dot{q}}{4k} (r_o^2 - r_i^2) + \frac{\dot{q} r_o^2}{2k} \ln \frac{r_o}{r_i} + T_s$$

where  $T_s$ , the inner surface temperature of the wall at the exit, follows from

$$q_s'' = \frac{\dot{q}(\pi/4) (D_o^2 - D_i^2)L}{\pi D_i L} = \frac{\dot{q}(D_o^2 - D_i^2)}{4 D_i} = h(T_s - T_{m,o})$$

where  $h$  is the local convection coefficient at the exit. With

$$Re_D = \frac{4 \dot{m}}{\pi D_i \mu} = \frac{4 \times 0.1 \text{ kg/s}}{\pi (0.02 \text{ m}) 803 \times 10^{-6} \text{ N} \cdot \text{s/m}^2} = 7928$$

the flow is turbulent and, with  $(L/D_i) = (8.87 \text{ m}/0.02 \text{ m}) = 444 \gg (x_{fd}/D) \approx 10$ , it is also fully developed. Hence, from the Gnielinski correlation, Eq. 8.62,

$$h = \frac{k}{D_i} \left[ \frac{(f/8)(Re_D - 1000) Pr}{1 + 12.7(f/8)^{1/2} (Pr^{2/3} - 1)} \right]$$

$$= \frac{0.617 \text{ W/m} \cdot \text{K}}{0.02 \text{ m}} \left[ \frac{(0.033618)(7928 - 1000)5.45}{1 + 12.7(0.033618)^{1/2} (5.45^{2/3} - 1)} \right] = 1796 \text{ W/m}^2 \cdot \text{K}$$

where from Eq. 8.21,  $f = (0.790 \ln Re_D - 1.64)^{-2} = 0.0336$ . Hence, the inner surface temperature of the wall at the exit is

$$T_s = \frac{\dot{q}(D_o^2 - D_i^2)}{4 h D_i} + T_{m,o} = \frac{10^6 \text{ W/m}^3 [(0.04 \text{ m})^2 - (0.02 \text{ m})^2]}{4 \times 1796 \text{ W/m}^2 \cdot \text{K} (0.02 \text{ m})} + 40^\circ \text{C} = 48.4^\circ \text{C}$$

$$\text{and } T_{w,\max} = -\frac{10^6 \text{ W/m}^3}{4 \times 15 \text{ W/m} \cdot \text{K}} \left[ (0.02 \text{ m})^2 - (0.01 \text{ m})^2 \right]$$

$$+ \frac{10^6 \text{ W/m}^3 (0.02 \text{ m})^2}{2 \times 15 \text{ W/m} \cdot \text{K}} \ln \frac{0.02}{0.01} + 48.4^\circ \text{C} = 52.6^\circ \text{C}. \quad <$$

**COMMENTS:** The physical situation corresponds to a uniform surface heat flux, and  $T_m$  increases linearly with  $x$ . In the fully developed region,  $T_s$  also increases linearly with  $x$ .

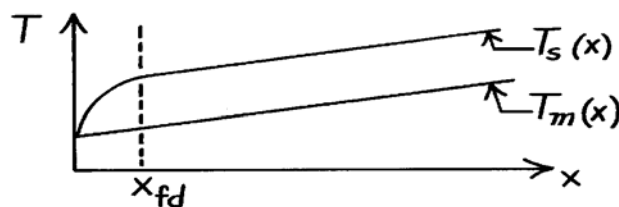

### PROBLEM 8.38

**KNOWN:** Inlet temperature, pressure and flow rate of air. Tube diameter and length. Pressure of saturated steam.

**FIND:** Outlet temperature and pressure of air. Mass rate of steam condensation.

**SCHEMATIC:**

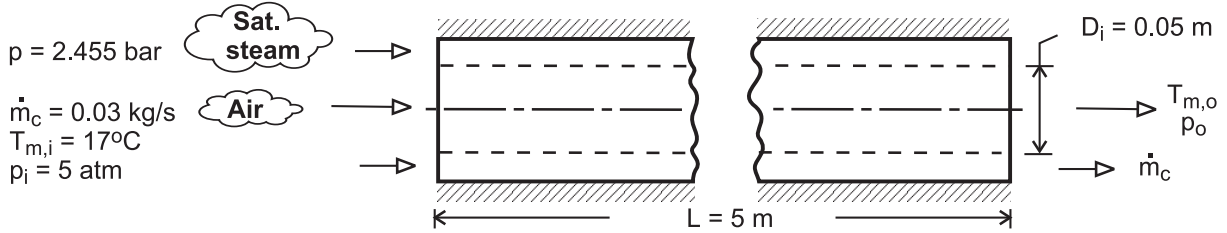

**ASSUMPTIONS:** (1) Steady-state, (2) Outer surface of annulus is adiabatic, (3) Ideal gas with negligible viscous dissipation and pressure variation, (4) Fully-developed flow throughout the tube, (5) Smooth tube surface, (6) Constant properties.

**PROPERTIES:** Table A-4, air ( $\bar{T}_m \approx 325$  K,  $p = 5$  atm):  $\rho = 5 \times \rho(1 \text{ atm}) = 5.391 \text{ kg/m}^3$ ,

$c_p = 1008 \text{ J/kg} \cdot \text{K}$ ,  $\mu = 196.4 \times 10^{-7} \text{ N} \cdot \text{s/m}^2$ ,  $k = 0.0281 \text{ W/m} \cdot \text{K}$ ,  $Pr = 0.703$ . Table A-6, sat. steam ( $p = 2.455$  bars):  $T_s = 400$  K,  $h_{fg} = 2183 \text{ kJ/kg}$ .

**ANALYSIS:** With a uniform surface temperature, the air outlet temperature is

$$T_{m,o} = T_s - (T_s - T_{m,i}) \exp\left(-\frac{\pi D_i L \bar{h}}{\dot{m} c_p}\right)$$

With  $Re_D = 4\dot{m}/\pi D_i \mu = 0.12 \text{ kg/s} / \pi (0.05 \text{ m}) 196.4 \times 10^{-7} \text{ kg/s} \cdot \text{m} = 38,980$ , the flow is turbulent, and the Dittus-Boelter correlation yields

$$\bar{h} \approx h_{fd} = \left(\frac{k}{D_i}\right) 0.023 Re_D^{4/5} Pr^{0.4} = \left(\frac{0.0281 \text{ W/m} \cdot \text{K}}{0.05 \text{ m}}\right) 0.023 (38,980)^{4/5} (0.703)^{0.4} = 52.8 \text{ W/m}^2 \cdot \text{K}$$

$$T_{m,o} = 127^\circ\text{C} - (110^\circ\text{C}) \exp\left(-\frac{\pi \times 0.05 \text{ m} \times 5 \text{ m} \times 52.8 \text{ W/m}^2 \cdot \text{K}}{0.03 \text{ kg/s} \times 1008 \text{ J/kg} \cdot \text{K}}\right) = 99^\circ\text{C} \quad <$$

The pressure drop is  $\Delta p = f \left(\rho u_m^2 / 2 D_i\right) L$ , where, with  $A_c = \pi D_i^2 / 4 = 1.963 \times 10^{-3} \text{ m}^2$ ,  $u_m = \dot{m} / \rho A_c = 2.83 \text{ m/s}$ , and with  $Re_D = 38,980$ , Eq. 8.21 gives  $f = [0.790 \ln(Re_D) - 1.64]^{-2} = 0.022$ . Hence,

$$\Delta p = 0.022 \times 5.391 \text{ kg/m}^3 \frac{(2.83 \text{ m/s})^2 5 \text{ m}}{2 \times 0.05 \text{ m}} = 47.5 \text{ N/m}^2 = 4.7 \times 10^{-4} \text{ atm} \quad <$$

The rate of heat transfer to the air is

$$q = \dot{m} c_p (T_{m,o} - T_{m,i}) = 0.03 \text{ kg/s} \times 1008 \text{ J/kg} \cdot \text{K} (82^\circ\text{C}) = 2480 \text{ W}$$

and the rate of condensation is then

$$\dot{m}_c = \frac{q}{h_{fg}} = \frac{2480 \text{ W}}{2.183 \times 10^6 \text{ J/kg}} = 1.14 \times 10^{-3} \text{ kg/s} \quad <$$

**COMMENTS:** (1) With  $\bar{T}_m = (T_{m,i} + T_{m,o}) / 2 = 331 \text{ K}$ , the initial estimate of 325 K is reasonable and iteration is not necessary. (2) For a steam flow rate of 0.01 kg/s, approximately 10% of the outflow would be in the form of saturated liquid, (3) With  $L/D_i = 100$ , it is reasonable to assume fully developed flow throughout the tube.

## PROBLEM 8.39

**KNOWN:** Fully-developed conditions for laminar or turbulent flow characterized by a fixed mass flow rate. Constant surface temperature conditions with  $T_s < T_m$ .

**FIND:** Determine whether a small or large diameter tube will be more effective in minimizing heat loss from the flowing fluid.

**SCHEMATIC:**

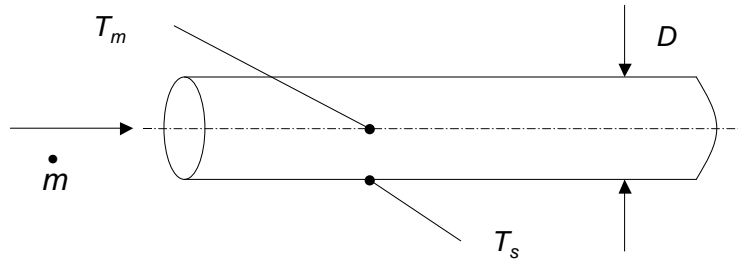

**ASSUMPTIONS:** (1) Fully-developed, (2) Constant properties, (3) Negligible viscous dissipation.

**ANALYSIS:** The heat loss rate per unit tube length is

$$q' = \pi D h (T_s - T_m) \quad \text{where } h = Nu_D k / D$$

Combining the preceding equations yields

$$q' = \pi Nu_D k (T_s - T_m) \quad (1)$$

### Laminar Conditions

For laminar conditions,  $Nu_D = 3.66$ . Substituting this expression into Eq. (1) yields

$$q' = 3.66 \pi k (T_s - T_m)$$

and the heat loss rate is independent of the tube diameter. <

### Turbulent Conditions

For turbulent flow, we may substitute the Dittus-Boelter correlation,  $Nu_D = 0.023 Re_D^{4/5} Pr^{0.3}$  with  $Re_D = (4\dot{m} / \pi D \mu)$  into Eq. (1) to find

$$q' = \pi (0.023) \left( \frac{4\dot{m}}{\pi \mu} \right)^{4/5} D^{-4/5} Pr^{0.3} k (T_s - T_m)$$

Hence, to minimize the heat loss, a large diameter tube is preferred. <

**COMMENTS:** The large diameter tube will result in reduced heat loss, but will be more expensive relative to a small diameter tube. If the cool surface temperature is induced by heat losses to the environment, a more effective approach to minimize heat loss would be to insulate the exterior of the tube.

## PROBLEM 8.40

**KNOWN:** Dimensions and thermal conductivity of concrete duct. Convection conditions of ambient air. Flow rate and inlet temperature of water flow through duct.

**FIND:** (a) Outlet temperature, (b) Pressure drop and pump power requirement, (c) Effect of flow rate and pipe diameter on outlet temperature.

**SCHEMATIC:**

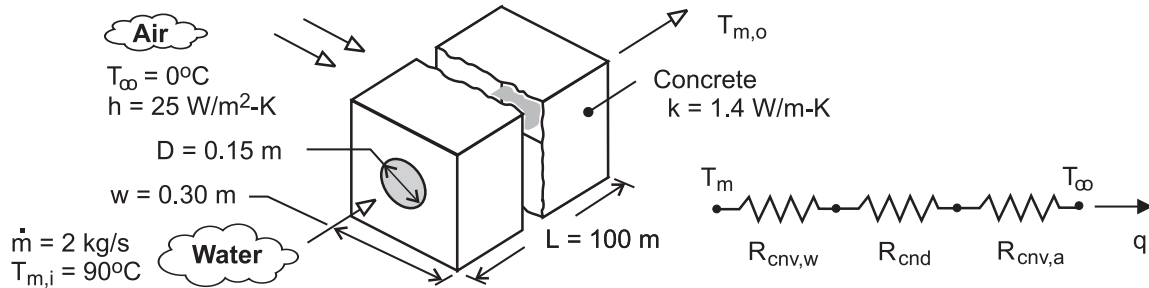

**ASSUMPTIONS:** (1) Steady-state, (2) Fully developed flow throughout duct, (3) Negligible pipe wall conduction resistance, (4) Water is incompressible liquid with negligible viscous dissipation, (5) Constant properties.

**PROPERTIES:** Table A-6, water ( $\bar{T}_m \approx 360 \text{ K}$ ):  $\rho = 967 \text{ kg/m}^3$ ,  $c_p = 4203 \text{ J/kg} \cdot \text{K}$ ,  $\mu = 324 \times 10^{-6} \text{ N} \cdot \text{s/m}^2$ ,  $k_w = 0.674 \text{ W/m} \cdot \text{K}$ ,  $\text{Pr} = 2.02$ .

**ANALYSIS:** (a) The outlet temperature is given by

$$T_{m,o} = T_\infty + (T_{m,i} - T_\infty) \exp(-UA / \dot{m} c_p)$$

where

$$UA = (R_{\text{tot}})^{-1} = (R_{\text{conv,w}} + R_{\text{cnd}} + R_{\text{conv,a}})^{-1}$$

From Table 4.1, Case 6,

$$R_{\text{cnd}} = \frac{\ln(1.08 w / D)}{2\pi k L} = \frac{\ln(1.08 \times 0.30 \text{ m} / 0.15 \text{ m})}{2\pi (1.4 \text{ W/m} \cdot \text{K}) 100 \text{ m}} = 8.75 \times 10^{-4} \text{ K/W}$$

$$R_{\text{conv,a}} = (4 w L h)^{-1} = (4 \times 0.30 \text{ m} \times 100 \text{ m} \times 25 \text{ W/m}^2 \cdot \text{K})^{-1} = 3.33 \times 10^{-4} \text{ K/W}$$

With  $\text{Re}_D = 4 \dot{m} / \pi D \mu = (4 \times 2 \text{ kg/s}) / (\pi \times 0.15 \text{ m} \times 324 \times 10^{-6} \text{ N} \cdot \text{s/m}^2) = 52,400$ ,

$$\bar{h}_w \approx h_{\text{fd}} = \frac{k_w}{D} 0.023 \text{Re}_D^{4/5} \text{Pr}^{0.3} = \frac{0.674 \text{ W/m} \cdot \text{K} \times 0.023}{0.15 \text{ m}} (52,400)^{4/5} (2.02)^{0.3} = 761 \text{ W/m}^2 \cdot \text{K}$$

$$R_{\text{conv,w}} = (\pi D L \bar{h}_w)^{-1} = (\pi \times 0.15 \text{ m} \times 100 \text{ m} \times 761 \text{ W/m}^2 \cdot \text{K})^{-1} = 2.79 \times 10^{-5} \text{ K/W}$$

$$UA = \left[ (2.79 \times 10^{-5} + 8.75 \times 10^{-4} + 3.33 \times 10^{-4}) \text{ K/W} \right]^{-1} = 809 \text{ W/K}$$

$$T_{m,o} = 0^\circ\text{C} + 90^\circ\text{C} \exp\left(-\frac{809 \text{ W/K}}{2 \text{ kg/s} \times 4203 \text{ J/kg} \cdot \text{K}}\right) = 81.7^\circ\text{C}$$

<

Continued ...



### PROBLEM 8.40 (Cont.)

(b) From Eq. 8.21,  $f = [0.790 \ln(\text{Re}_D) - 1.64]^{-2} = 0.0207$  and  $u_m = \dot{m} / \rho \pi D^2 / 4 = 0.117 \text{ m/s}$ ,

$$\Delta p = f \frac{\rho u_m^2}{2D} L = 0.0207 \frac{967 \text{ kg/m}^3 (0.117 \text{ m/s})^2}{2 \times 0.15 \text{ m}} 100 \text{ m} = 91 \text{ N/m}^2 = 9.1 \times 10^{-4} \text{ bars} \quad <$$

With  $\dot{V} = \dot{m} / \rho = 2.07 \times 10^{-3} \text{ m}^3/\text{s}$ , the pump power requirement is

$$P = \Delta p \dot{V} = (91 \text{ N/m}^2) 2.07 \times 10^{-3} \text{ m}^3/\text{s} = 0.19 \text{ W} \quad <$$

(c) The effects of varying the flowrate and duct diameter were assessed using the IHT software, and results are shown below.

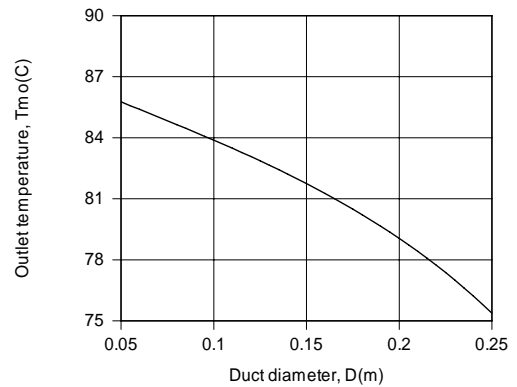
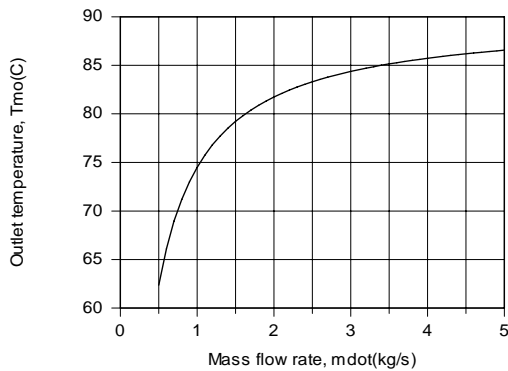

Although  $R_{\text{cnv},w}$ , and hence  $R_{\text{tot}}$ , decreases with increasing  $\dot{m}$ , thereby increasing  $UA$ , the effect is significantly less than that of  $\dot{m}$  to the first power, causing the exponential term,  $\exp(-UA / \dot{m} c_p)$ , to approach unity and  $T_{m,o}$  to approach  $T_{m,i}$ . The effect can alternatively be attributed to a reduction in the residence time of the water in the pipe ( $u_m$  increases with increasing  $\dot{m}$  for fixed  $D$ ). With increasing  $D$  for fixed  $\dot{m}$  and  $w$ ,  $T_{m,o}$  decreases due to an increase in the residence time, as well as a reduction in the conduction resistance,  $R_{\text{cnd}}$ .

**COMMENTS:** (1) Use of  $\bar{T}_m = 360 \text{ K}$  to evaluate properties of the water for Parts (a) and (b) is reasonable, and iteration is not necessary. (2) The pressure drop and pump power requirement are small.

### PROBLEM 8.41

**KNOWN:** Water flow through a thick-walled tube immersed in a well stirred, hot reaction tank maintained at 85°C; conduction thermal resistance of the tube wall based upon the inner surface area is  $R''_{cd} = 0.002 \text{ m}^2 \cdot \text{K} / \text{W}$ .

**FIND:** (a) The outlet temperature of the process fluid,  $T_{m,o}$ ; assume, and then justify, fully developed flow and thermal conditions within the tube; and (b) Do you expect  $T_{m,o}$  to increase or decrease if the combined entry condition exists within the tube? Estimate the outlet temperature of the process fluid for this condition.

**SCHEMATIC:**

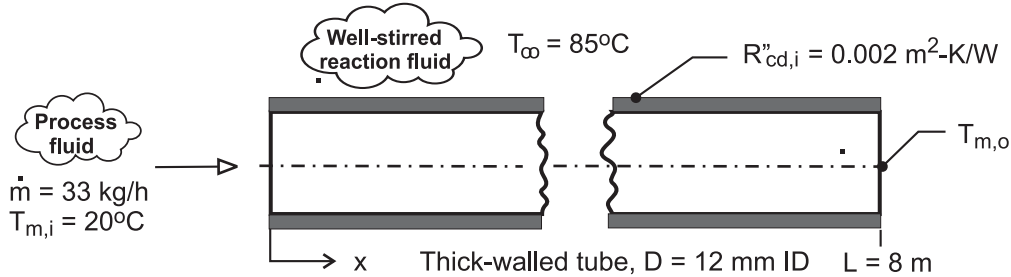

**ASSUMPTIONS:** (1) Flow is fully developed, part (a), (2) Constant properties, (3) Incompressible liquid with negligible viscous dissipation, and (4) Constant wall temperature heating, with  $T_s \approx T_{\infty}$  because of small thermal resistance associated with well-stirred reaction fluid.

**PROPERTIES:** Table A-6, Water ( $T_m = (T_{m,o} + T_{m,i})/2 = 315 \text{ K}$ ):  $c_p = 4179 \text{ J/kg}\cdot\text{K}$ ,  $\mu = 6.31 \times 10^{-4} \text{ N}\cdot\text{s/m}^2$ ,  $k = 0.634 \text{ W/m}\cdot\text{K}$ ,  $\text{Pr} = 4.16$ .

**ANALYSIS:** (a) The outlet temperature is determined from the rate equation, Eq. 8.45a, written as

$$\frac{T_s - T_{m,o}}{T_s - T_{m,i}} = \exp\left(-\frac{\bar{U}A_s}{\dot{m}c_p}\right) \quad (1)$$

where the overall coefficient, based upon the inner surface area of the tube is expressed in terms of the convection and conduction thermal resistances,

$$\frac{1}{\bar{U}} = \frac{1}{h} + R''_{cd,i} \quad (2)$$

To estimate  $\bar{h}$ , begin by characterizing the flow

$$\text{Re}_D = 4\dot{m}/\pi D\mu \quad (3)$$

$$\text{Re}_D = 4(33/3600 \text{ kg/s})/\pi \times 0.012 \text{ m} \times 6.31 \times 10^{-4} \text{ N}\cdot\text{s/m}^2 = 1540$$

Consider the flow as laminar, and assuming fully developed conditions, estimate  $\bar{h}$  with the correlation of Eq. 8.55,

$$\bar{\text{Nu}}_D = \bar{h}D/k = 3.66 \quad (4)$$

$$\bar{h} = 3.66 \times 0.634 \text{ W/m}\cdot\text{K} / 0.012 \text{ m} = 193 \text{ W/m}^2 \cdot \text{K}$$

From Eq. (2),

$$\bar{U} = \left[1/193 \text{ W/m}^2 \cdot \text{K} + 0.002 \text{ m}^2 \cdot \text{K/W}\right]^{-1} = 139 \text{ W/m}^2 \cdot \text{K}$$

and from Eq. (1), with  $A_s = \pi DL$ , calculate  $T_{m,o}$ .

Continued ...

**PROBLEM 8.41 (Cont.)**

$$\frac{85 - T_{m,o}}{85 - 20} = \exp\left(-\frac{139 \text{ W/m}^2 \cdot \text{K} \times \pi \times 0.012 \text{ m} \times 8 \text{ m}}{33/3600 \text{ kg/s} \times 4179 \text{ J/kg} \cdot \text{K}}\right)$$

$$T_{m,o} = 63^\circ\text{C} \quad \leftarrow$$

Fully developed flow and thermal conditions are justified if the tube length is much greater than the fully developed lengths  $x_{fd,h}$  and  $x_{fd,t}$ . From Eqs. 8.3 and 8.23,

$$\begin{aligned} x_{fd,h} &= 0.05 \text{ Re}_D D = 0.05 \times 1540 \times 0.012 \text{ m} = 0.92 \text{ m} \\ x_{fd,t} &= x_{fd,h} \text{ Pr} = 0.92 \text{ m} \times 4.16 = 3.8 \text{ m} \end{aligned}$$

That is, while fully developed velocity conditions may be justifiable, the length is only twice that required to reach *thermally* fully developed conditions.

(b) We expect the calculated outlet temperature to be larger if the combined entrance effect exists, since the average heat transfer coefficient would be larger relative to that associated with fully-developed conditions. ←

Considering combined entry length conditions, estimate the convection coefficient using the Baehr and Stephan correlation, Eq. 8.58, where from Eq. 8.56,  $Gz_D = (D/L)\text{Re}_D\text{Pr} = (0.012 \text{ m}/8 \text{ m}) \times 1540 \times 4.16 = 9.61$ :

$$\begin{aligned} \overline{\text{Nu}}_D &= \frac{\bar{h}D}{k} = \frac{\frac{3.66}{\tanh[2.264Gz_D^{-1/3} + 1.7Gz_D^{-2/3}]} + 0.0499Gz_D \tanh(Gz_D^{-1})}{\tanh(2.432 \text{ Pr}^{1/6} Gz_D^{-1/6})} \quad (5) \\ \bar{h} &= \frac{0.634 \text{ W/m} \cdot \text{K}}{0.012 \text{ m}} \left( \frac{\frac{3.66}{\tanh[2.264 \times 9.61^{-1/3} + 1.7 \times 9.61^{-2/3}]} + 0.0499 \times 9.61 \tanh(9.61^{-1})}{\tanh(2.432 \times 4.16^{1/6} \times 9.61^{-1/6})} \right) = 225 \text{ W/m}^2 \cdot \text{K} \end{aligned}$$

which is a 17% increase over the fully developed analysis result. Using the foregoing relations, find

$$U = 155 \text{ W/m}^2 \cdot \text{K}$$

$$T_{m,o} = 65.9^\circ\text{C} \quad \leftarrow$$

**COMMENTS:** (1) The thermophysical properties for the fully developed correlation should be evaluated at the mean fluid temperature  $T_m = (T_{m,o} + T_{m,i})/2 = 316 \text{ K}$ . This is very close to the assumed value of 315 K. (2) For the Baehr and Stephan correlation, the properties are also evaluated at  $T_m$ . (3) For this case where the tube length is about twice  $x_{fd,t}$ , the average heat transfer coefficient is larger than the fully developed value, as we would expect. (4) The thermal entry length correlation due to Hausen yields  $\bar{h} = 222 \text{ W/m}^2 \cdot \text{K}$ , close to the combined entry length value. This is not surprising, considering that the Prandtl number of 4.16 is close to meeting the  $\text{Pr} > 5$  condition for the Hausen correlation to be valid.

## PROBLEM 8.42

**KNOWN:** Flow rate and temperature of atmospheric air entering a duct of prescribed diameter, length and surface temperature.

**FIND:** (a) Air outlet temperature and duct heat loss for the prescribed conditions and (b) Calculate and plot  $q$  and  $\Delta p$  for the range of diameters,  $0.1 \leq D \leq 0.2$  m, maintaining the total surface area,  $A_s = \pi DL$ , at the same value as part (a). Explain the trade off between the heat transfer rate and pressure drop.

**SCHEMATIC:**

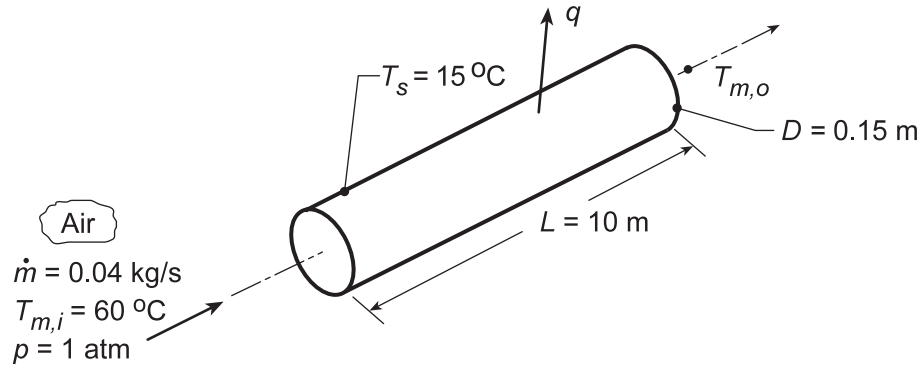

**ASSUMPTIONS:** (1) Steady-state conditions, (2) Constant properties, (3) Ideal gas with negligible viscous dissipation and pressure variation, (4) Uniform surface temperature, (5) Fully developed flow conditions.

**PROPERTIES:** Table A.4, Air ( $\bar{T}_m \approx 310 \text{ K}$ , 1 atm):  $\rho = 1.128 \text{ kg/m}^3$ ,  $c_p = 1007 \text{ J/kg}\cdot\text{K}$ ,  $\mu = 189 \times 10^{-7} \text{ N}\cdot\text{s/m}^2$ ,  $k = 0.027 \text{ W/m}\cdot\text{K}$ ,  $\text{Pr} = 0.706$ .

**ANALYSIS:** (a) With

$$\text{Re}_D = \frac{4\dot{m}}{\pi D \mu} = \frac{4 \times 0.04 \text{ kg/s}}{\pi (0.15 \text{ m}) 189 \times 10^{-7} \text{ N}\cdot\text{s/m}^2} = 17,965$$

the flow is turbulent. Assuming fully developed conditions throughout the tube, it follows from the Dittus-Boelter correlation, Eq. 8.60, that

$$\bar{h} = \frac{k}{D} 0.023 \text{Re}_D^{4/5} \text{Pr}^{0.3} = \frac{0.027 \text{ W/m}\cdot\text{K}}{0.15 \text{ m}} 0.023 (17,965)^{4/5} (0.706)^{0.3} = 9.44 \text{ W/m}^2 \cdot \text{K}.$$

Hence, from the energy balance relation, Eq. 8.41b,

$$T_{m,o} = T_s - (T_s - T_{m,i}) \exp\left(-\frac{\pi DL \bar{h}}{\dot{m} c_p}\right)$$

$$T_{m,o} = 15^\circ\text{C} + 45^\circ\text{C} \exp\left(-\frac{\pi (0.15 \text{ m}) 10 \text{ m} (9.44 \text{ W/m}^2 \cdot \text{K})}{0.04 \text{ kg/s} (1007 \text{ J/kg}\cdot\text{K})}\right) = 29.9^\circ\text{C} \quad <$$

From the overall energy balance, Eq. 8.34, it follows that

$$q = \dot{m} c_p (T_{m,o} - T_{m,i}) = 0.04 \text{ kg/s} \times 1007 \text{ J/kg}\cdot\text{K} (29.9 - 60)^\circ\text{C} = -1212 \text{ W} . \quad <$$

From Eq. 8.22a, the pressure drop is

$$\Delta p = f \frac{\rho u_m^2}{2D} L$$

Continued...

### PROBLEM 8.42 (Cont.)

and for the smooth surface conditions, Eq. 8.21 can be used to evaluate the friction factor,

$$f = (0.790 \ln(\text{Re}_D) - 1.64)^{-2} = (0.790 \ln(17,965) - 1.64)^{-2} = 0.0269$$

Hence, the pressure drop is

$$\Delta p = 0.0269 \frac{1.128 \text{ kg/m}^3 (2.0 \text{ m/s})^2}{2 \times 0.15 \text{ m}} \times 10 \text{ m} = 4.03 \text{ N/m}^2$$

where  $u_m = \dot{m} / \rho A_c = 0.04 \text{ kg/s} / 1.128 \text{ kg/m}^3 \times (\pi 0.15^2 \text{ m}^2 / 4) = 2.0 \text{ m/s}$ .

(b) For the prescribed conditions of part (a),  $A_s = \pi DL = \pi(0.15 \text{ m}) \times 10 \text{ m} = 4.712 \text{ m}^2$ , using the *IHT Correlations Tool, Internal Flow* for fully developed *Turbulent Flow* along with the energy balance equation, rate equation and pressure drop equations used above, the heat rate  $q$  and  $\Delta p$  are calculated and plotted below.

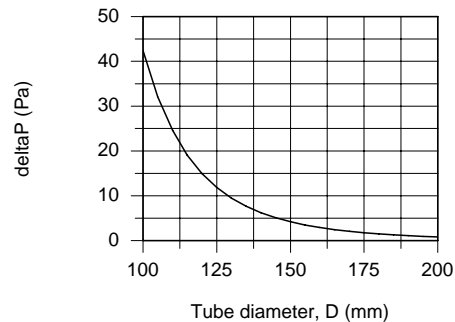
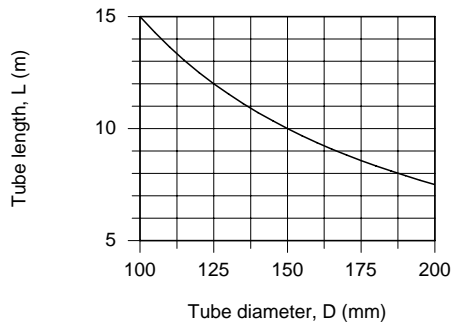

From above, as  $D$  increases,  $L$  decreases so that  $A_s$  remains unchanged. The decrease in heat rate with increasing diameter is nearly linear, while the pressure drop decreases markedly. This is the trade off: increased heat rate requires a more significant increase in pressure drop, and hence fan blower power requirements.

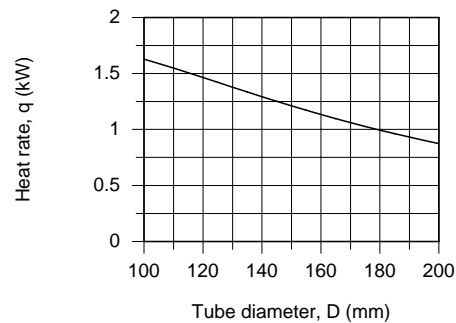

**COMMENTS:** (1) To check the calculations, compute  $q$  from Eq. 8.43, where  $\Delta T_{\ell m}$  is given by Eq. 8.44. It follows that  $\Delta T_{\ell m} = -27.1^\circ\text{C}$  and  $q = -1206 \text{ W}$ . The small difference in results may be attributed to round-off error.

(2) For part (a), a slight improvement in accuracy may be obtained by evaluating the properties at  $\bar{T}_m = 318 \text{ K}$ :  $\bar{h} = 9.42 \text{ W/m}^2\cdot\text{K}$ ,  $T_{m,o} = 303 \text{ K} = 30^\circ\text{C}$ ,  $q = -1211 \text{ W}$ ,  $f = 0.0271$  and  $\Delta p = 4.20 \text{ N/m}^2$ .

## PROBLEM 8.43

**KNOWN:** Flow rate of NaK, NaK inlet and outlet temperatures, tube wall temperature, tube diameter.

**FIND:** Tube length, and local convective flux at the tube exit.

**SCHEMATIC:**

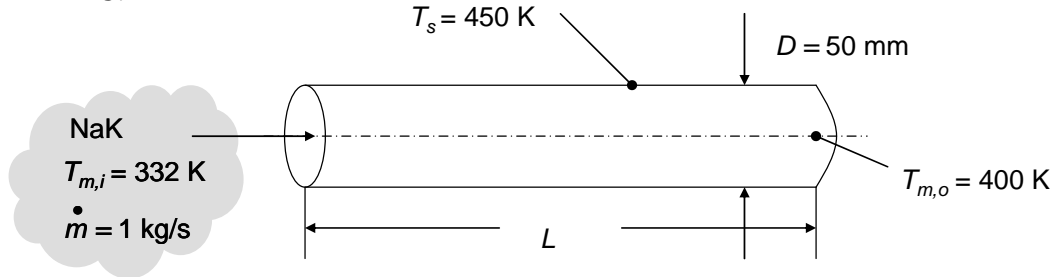

**ASSUMPTIONS:** (1) Constant properties, (2) Negligible viscous dissipation, (3) Fully developed flow.

**PROPERTIES:** Table A.7 NaK (45%/55%);  $\bar{T}_m = (332\text{K} + 400\text{K})/2 = 366\text{K}$ :  $\rho = 887 \text{ kg/m}^3$ ,  $k = 25.6 \text{ W/m}\cdot\text{K}$ ,  $\nu = 6.52 \times 10^{-7} \text{ m}^2/\text{s}$ ,  $Pr = 0.026$ ,  $c_p = 1130 \text{ J/kg}\cdot\text{K}$ .

**ANALYSIS:** The Reynolds number is

$$Re_D = 4\dot{m} / \pi D \nu \rho = 4 \times 1 \text{ kg/s} / \left[ \pi \times 0.05 \text{ m} \times 6.52 \times 10^{-7} \text{ m}^2/\text{s} \times 887 \text{ kg/m}^3 \right] = 44,000$$

and the flow is turbulent. The Peclet number is  $Pe_D = Re_D Pr = 44,000 \times 0.026 = 1145$ . Therefore, we may use Eq. 8.65 if the flow is fully developed. Hence,

$$h = \frac{k}{D} \left( 5.0 + 0.025 Pe_D^{0.8} \right) = \frac{25.6 \text{ W/m}\cdot\text{K}}{0.05 \text{ m}} \times \left( 5.0 + 0.025 \times 1145^{0.8} \right) = 6140 \text{ W/m}^2 \cdot \text{K}$$

The required tube length is, from Eq. 8.41a,

$$L = -\frac{\dot{m} c_p}{\pi D h} \ln \frac{\Delta T_o}{\Delta T_i} = -\frac{1 \text{ kg/s} \times 1130 \text{ J/kg}\cdot\text{K}}{\pi \times 0.05 \text{ m} \times 6140 \text{ W/m}^2 \cdot \text{K}} \ln \left( \frac{50}{118} \right) = 1 \text{ m} \quad <$$

The local convective heat flux at  $x = L = 1 \text{ m}$  is

$$q'' = h(T_s - T_{m,o}) = 6140 \text{ W/m}^2 \cdot \text{K} \times (450 - 400) \text{ K} = 30,700 \text{ W/m}^2 \quad <$$

**COMMENTS:** The dimensionless tube length is  $L/D = 1\text{m}/0.05\text{m} = 20$ . The flow is therefore fully developed, and use of Eq. 8.65 is appropriate.

## PROBLEM 8.44

**KNOWN:** Duct diameter and length. Thermal conductivity of insulation. Gas inlet temperature and velocity and minimum allowable outlet temperature. Temperature and velocity of air in cross flow.

**FIND:** Minimum allowable insulation thickness.

**SCHEMATIC:**

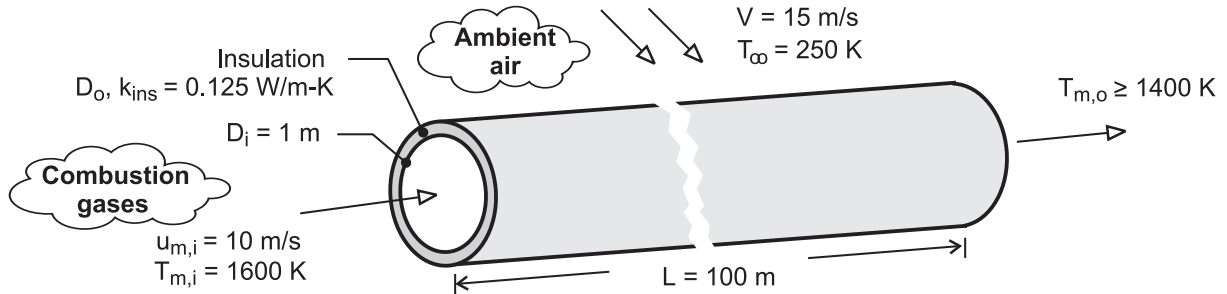

**ASSUMPTIONS:** (1) Combustion gases are ideal with negligible viscous dissipation and pressure variation, (2) Fully developed flow throughout duct, (3) Negligible duct wall conduction resistance, (4) Negligible effect of insulation thickness on outer convection coefficient and thermal resistance, (5) Properties of gas may be approximated as those of air.

**PROPERTIES:** Table A-4, air ( $p = 1 \text{ atm}$ ).  $T_{m,i} = 1600 \text{ K}$ : ( $\rho_i = 0.218 \text{ kg/m}^3$ ).  $\bar{T}_m = (T_{m,i} + T_{m,o})/2 = 1500 \text{ K}$ : ( $\rho = 0.232 \text{ kg/m}^3$ ,  $c_p = 1230 \text{ J/kg}\cdot\text{K}$ ,  $\mu = 557 \times 10^{-7} \text{ N}\cdot\text{s/m}^2$ ,  $k = 0.100 \text{ W/m}\cdot\text{K}$ ,  $\text{Pr} = 0.685$ ).  $T_f \approx 300 \text{ K}$  (assumed): ( $\nu = 15.89 \times 10^{-6} \text{ m}^2/\text{s}$ ,  $k = 0.0263 \text{ W/m}\cdot\text{K}$ ,  $\text{Pr} = 0.707$ ).

**ANALYSIS:** From Eqs. (8.45a) and (3.19),

$$\frac{T_\infty - T_{m,o}}{T_\infty - T_{m,i}} = \frac{-1150 \text{ K}}{-1350 \text{ K}} = 0.852 = \exp\left(-\frac{\bar{U}A_s}{\dot{m}c_p}\right) = \exp\left(-\frac{1}{R_{\text{tot}}\dot{m}c_p}\right)$$

Hence, with  $\dot{m} = (\rho u_m A_c)_i = 0.218 \text{ kg/m}^3 \times 10 \text{ m/s} \times \pi(1\text{m})^2/4 = 1.712 \text{ kg/s}$ ,

$$R_{\text{tot}} = -\left[\dot{m}c_p \ln(0.852)\right]^{-1} = -\left[1.712 \text{ kg/s} \times 1230 \text{ J/kg}\cdot\text{K} \times (-0.160)\right]^{-1} = 2.96 \times 10^{-3} \text{ K/W}$$

The total thermal resistance is

$$R_{\text{tot}} = R_{\text{conv},i} + R_{\text{cond,ins}} + R_{\text{conv},o} = (h_i \pi D_i L)^{-1} + \frac{\ln(D_o/D_i)}{2\pi k_{\text{ins}} L} + (h_o \pi D_o L)^{-1} \quad (1)$$

With  $\text{Re}_{D,i} = 4\dot{m}/\pi D_i \mu = (4 \times 1.712 \text{ kg/s})/(\pi \times 1\text{m} \times 557 \times 10^{-7} \text{ N}\cdot\text{s/m}^2) = 39,130$ , the Dittus-Boelter correlation yields

$$h_i = \left(\frac{k}{D}\right) 0.023 \text{Re}_D^{4/5} \text{Pr}^{0.3} = \left(\frac{0.100 \text{ W/m}\cdot\text{K}}{1\text{m}}\right) 0.023 (39,130)^{4/5} (0.685)^{0.3} = 9.69 \text{ W/m}^2 \cdot \text{K}$$

The internal resistance is then

$$R_{\text{conv},i} = (h_i \pi D_i L)^{-1} = \left(9.69 \text{ W/m}^2 \cdot \text{K} \times \pi \times 1\text{m} \times 100\text{m}\right)^{-1} = 3.28 \times 10^{-4} \text{ K/W}$$

With  $\text{Re}_D \approx VD_i/\nu = 15 \text{ m/s} \times 1\text{m}/15.89 \times 10^{-6} \text{ m}^2/\text{s} = 9.44 \times 10^5$ , the Churchill-Bernstein correlation yields

Continued ...

**PROBLEM 8.44 (Cont.)**

$$h_o \approx \left(\frac{k}{D}\right) \left\{ 0.3 + \frac{0.62 \text{Re}_D^{1/2} \text{Pr}^{1/3}}{\left[1 + (0.4/\text{Pr})^{2/3}\right]^{1/4}} \left[1 + \left(\frac{\text{Re}_D}{282,000}\right)^{5/8}\right]^{4/5} \right\} = 30.9 \text{ W/m}^2 \cdot \text{K}$$

$$R_{\text{conv},o} \approx (h_o \pi D_i L)^{-1} = (30.9 \text{ W/m}^2 \cdot \text{K} \times \pi \times 1\text{m} \times 100\text{m})^{-1} = 1.03 \times 10^{-4} \text{ K/W}$$

Hence, from Eq. (1)

$$\frac{\ln(D_o/D_i)}{2\pi k_{\text{ins}} L} = (2.96 \times 10^{-3} - 3.33 \times 10^{-4} - 1.03 \times 10^{-4}) \text{ K/W} = 2.53 \times 10^{-3} \text{ K/W}$$

$$D_o = D_i \exp(2\pi k_{\text{ins}} L \times 2.53 \times 10^{-3} \text{ K/W}) = 1\text{m} \times \exp(1.59 \times 10^{-2} \text{ K/W} \times 0.125 \text{ W/m} \cdot \text{K} \times 100\text{m}) = 1.22\text{m}$$

Hence, the minimum insulation thickness is

$$t_{\text{min}} = (D_o - D_i)/2 = 0.11\text{m} \quad <$$

**COMMENTS:** With  $D_o = 1.22\text{m}$ , use of  $D_i = 1\text{m}$  to evaluate the outer convection coefficient and thermal resistance is a reasonable approximation. However, improved accuracy may be obtained by using the calculated value of  $D_o$  to determine conditions at the outer surface and iterating on the solution.



### PROBLEM 8.45

**KNOWN:** Flow rate, inlet temperature and desired outlet temperature of liquid mercury flowing through a tube of prescribed diameter and surface temperature.

**FIND:** Required tube length and error associated with use of a correlation for moderate to large Pr fluids.

**SCHEMATIC:**

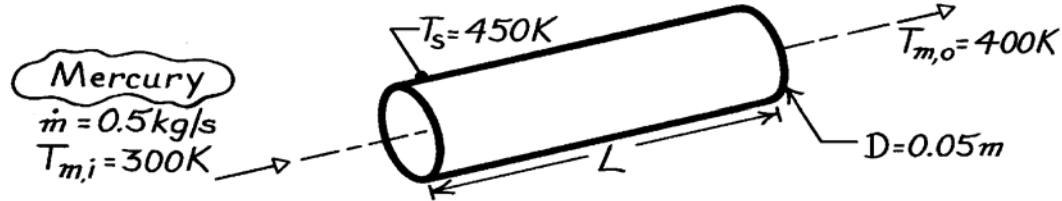

**ASSUMPTIONS:** (1) Steady-state conditions, (2) Constant properties, (3) Incompressible liquid with negligible viscous dissipation, (4) Fully developed flow.

**PROPERTIES:** Table A-5, Mercury ( $\bar{T}_m = 350\text{K}$ ):  $c_p = 137.7\text{ J/kg}\cdot\text{K}$ ,  $\mu = 0.1309 \times 10^{-2}\text{ N}\cdot\text{s/m}^2$ ,  $k = 9.18\text{ W/m}\cdot\text{K}$ ,  $\text{Pr} = 0.0196$ .

**ANALYSIS:** The Reynolds and Peclet numbers are

$$\text{Re}_D = \frac{4\dot{m}}{\pi D\mu} = \frac{4 \times 0.5\text{ kg/s}}{\pi (0.05\text{ m}) 0.1309 \times 10^{-2}\text{ N}\cdot\text{s/m}^2} = 9727$$

$$\text{Pe}_D = \text{Re}_D \text{Pr} = 9727 (0.0196) = 191.$$

Hence, assuming fully developed turbulent flow throughout the tube, it follows from Eq. 8.65 that

$$\bar{h} = \frac{k}{D} \left( 5.0 + 0.025 \text{Pe}_D^{0.8} \right) = \frac{9.18\text{ W/m}\cdot\text{K}}{0.05\text{ m}} \left( 5.0 + 0.025 \times 191^{0.8} \right) = 1224\text{ W/m}^2\cdot\text{K}.$$

From Eq. 8.41a, it follows that

$$L = -\frac{\dot{m} c_p}{\pi Dh} \ln \frac{\Delta T_o}{\Delta T_i} = -\frac{(0.5\text{ kg/s}) 137.7\text{ J/kg}\cdot\text{K}}{\pi (0.05\text{ m}) 1224\text{ W/m}^2\cdot\text{K}} \ln \frac{450 - 400}{450 - 300} = 0.39\text{ m}. \quad <$$

If the Dittus-Boelter correlation, Eq. 8.60, is used in place of Eq. 8.65,

$$\bar{h} = \frac{k}{D} 0.023 \text{Re}_D^{4/5} \text{Pr}^{0.4} = \frac{9.18\text{ W/m}^2\cdot\text{K}}{0.05\text{ m}} 0.023 (9727)^{4/5} (0.0196)^{0.4} = 1358\text{ W/m}^2\cdot\text{K}$$

and the required tube length is

$$L = -\frac{\dot{m} c_p}{\pi Dh} \ln \frac{\Delta T_o}{\Delta T_i} = -\frac{(0.5\text{ kg/s}) 137.7\text{ J/kg}\cdot\text{K}}{\pi (0.05\text{ m}) 1358\text{ W/m}^2\cdot\text{K}} \ln \frac{450 - 400}{450 - 300} = 0.35\text{ m}. \quad <$$

**COMMENTS:** (1) Such good agreement between results does not occur in general. For example, if  $\text{Re}_D = 2 \times 10^4$ ,  $\bar{h} = 1463$  from Eq. 8.65 and 2417 from Eq. 8.60. Large errors are usually associated with using conventional (moderate to large Pr) correlations with liquid metals. (2) The Dittus-Boelter correlation is recommended for  $\text{Re}_D \geq 10,000$ , which is not quite satisfied here.

### PROBLEM 8.46

**KNOWN:** Surface temperature and diameter of a tube. Velocity and temperature of air in cross flow. Velocity and temperature of air in fully developed internal flow.

**FIND:** Convection heat flux associated with the external and internal flows.

**SCHEMATIC:**

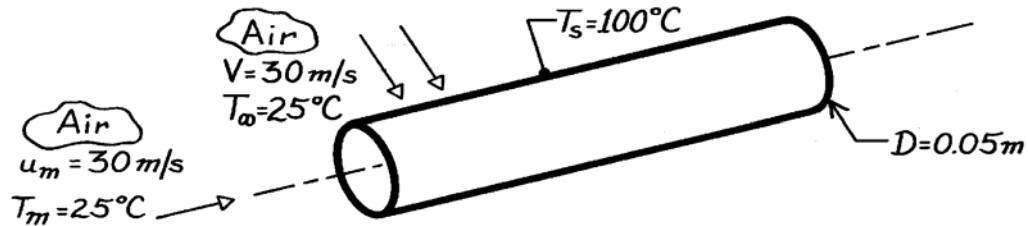

**ASSUMPTIONS:** (1) Steady-state conditions, (2) Uniform cylinder surface temperature, (3) Fully developed internal flow, (4) For internal flow, air is an ideal gas with negligible viscous dissipation and pressure variations.

**PROPERTIES:** Table A-4, Air (336 K):  $\nu = 19.51 \times 10^{-6} \text{ m}^2/\text{s}$ ,  $k = 0.0290 \text{ W/m}\cdot\text{K}$ ,  $\text{Pr} = 0.702$ .

**ANALYSIS:** For the *external* and *internal* flows,

$$\text{Re}_D = \frac{VD}{\nu} = \frac{u_m D}{\nu} = \frac{30 \text{ m/s} \times 0.05 \text{ m}}{19.71 \times 10^{-6} \text{ m}^2/\text{s}} = 7.69 \times 10^4.$$

From the Churchill-Bernstein relation for the *external* flow,

$$\begin{aligned} \overline{\text{Nu}}_D &= 0.3 + \frac{0.62 \text{Re}_D^{1/2} \text{Pr}^{1/3}}{\left[1 + (0.4/\text{Pr})^{2/3}\right]^{1/4}} \left[1 + \left(\frac{\text{Re}_D}{282,000}\right)^{5/8}\right]^{4/5} \\ &= 0.3 + \frac{0.62(7.69 \times 10^4)^{1/2} 0.702^{1/3}}{\left[1 + (0.4/0.702)^{2/3}\right]^{1/4}} \left[1 + \left(\frac{7.69 \times 10^4}{282,000}\right)^{5/8}\right]^{4/5} = 180 \end{aligned}$$

Hence, the convection coefficient and heat flux are

$$\bar{h} = \frac{k}{D} \overline{\text{Nu}}_D = \frac{0.0290 \text{ W/m}\cdot\text{K}}{0.05 \text{ m}} \times 180 = 104 \text{ W/m}^2 \cdot \text{K}$$

$$q'' = h(T_s - T_\infty) = 104 \text{ W/m}^2 \cdot \text{K} (100 - 25)^\circ\text{C} = 7840 \text{ W/m}^2. \quad \leftarrow$$

Using the Dittus-Boelter correlation, Eq. 8.60, for the *internal* flow, which is turbulent,

$$\overline{\text{Nu}}_D = 0.023 \text{Re}_D^{4/5} \text{Pr}^{0.4} = 0.023 (7.69 \times 10^4)^{4/5} (0.702)^{0.4} = 162$$

$$\bar{h} = \frac{k}{D} \overline{\text{Nu}}_D = \frac{0.0290 \text{ W/m}\cdot\text{K}}{0.05 \text{ m}} \times 162 = 94 \text{ W/m}^2 \cdot \text{K}$$

Continued...

**PROBLEM 8.46 (Cont.)**

and the heat flux is

$$q'' = h(T_s - T_m) = 94 \text{ W/m}^2 \cdot \text{K} (100 - 25)^\circ \text{C} = 7040 \text{ W/m}^2. \quad <$$

**COMMENT:** Convection effects associated with the two flow conditions are comparable.

### PROBLEM 8.47

**KNOWN:** Length and diameter of tube submerged in paraffin of prescribed dimensions. Inlet temperature and flow rate of water flowing through tube.

**FIND:** (a) Outlet temperature, heat rate, and time required for complete melting, and (b) Effect of flowrate on operating conditions.

**SCHEMATIC:**

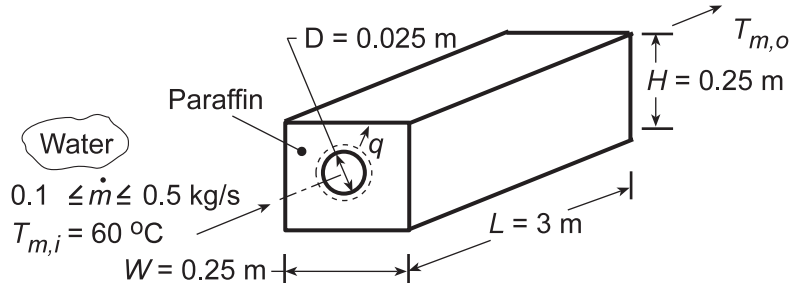

**ASSUMPTIONS:** (1) Negligible KE/PE and flow work changes for water, (2) Constant water properties, (3) Negligible tube wall conduction resistance, (4) Negligible convection resistance in melt ( $T_s = T_\infty = T_{mp}$ ), (5) Fully developed flow, (6) No heat loss to the surroundings.

**PROPERTIES:** Water (given):  $c_p = 4.185 \text{ kJ/kg}\cdot\text{K}$ ,  $k = 0.653 \text{ W/m}\cdot\text{K}$ ,  $\mu = 467 \times 10^{-6} \text{ kg/s}\cdot\text{m}$ ,  $\text{Pr} = 2.99$ ; Paraffin (given):  $T_{mp} = 27.4^\circ\text{C}$ ,  $h_{sf} = 244 \text{ kJ/kg}$ ,  $\rho = 770 \text{ kg/m}^3$ .

**ANALYSIS:** (a) From Eq. 8.41b,  $\frac{T_\infty - T_{m,o}}{T_\infty - T_{m,i}} = \exp\left(-\frac{\pi D L \bar{h}}{\dot{m} c_p}\right)$ . With  $\text{Re}_D = \frac{4\dot{m}}{\pi D \mu} =$

$\frac{4 \times 0.1 \text{ kg/s}}{\pi \times 0.025 \text{ m} \times 467 \times 10^{-6} \text{ kg/s}\cdot\text{m}} = 10,906$ , the flow is turbulent. Assuming fully developed conditions,

$$h = \frac{\text{Nu}_D k}{D} = \frac{k}{D} 0.023 \text{Re}_D^{4/5} \text{Pr}^{0.3} = \frac{0.653 \text{ W/m}\cdot\text{K}}{0.025 \text{ m}} 0.023 (10,906)^{4/5} (2.99)^{0.3} = 1418 \text{ W/m}^2\cdot\text{K}$$

$$T_{m,o} = 27.4^\circ\text{C} - (27.4 - 60)^\circ\text{C} \exp\left(-\frac{\pi \times 0.025 \text{ m} \times 3 \text{ m}}{0.1 \text{ kg/s} \times 4185 \text{ J/kg}\cdot\text{K}} 1418 \text{ W/m}^2\cdot\text{K}\right) = 42.17^\circ\text{C} <$$

From the overall energy balance,

$$q = \dot{m} c_p (T_{m,i} - T_{m,o}) = 0.1 \text{ kg/s} \times 4185 \text{ J/kg}\cdot\text{K} (60 - 42.17)^\circ\text{C} = 7500 \text{ W} <$$

Applying an energy balance to a control volume about the paraffin,  $E_{in} = \Delta E_{st}$ , the time  $t_m$  required to melt the paraffin is

$$q t_m = \rho V h_{sf} = \rho L \left( W H - \pi D^2 / 4 \right) h_{sf}$$

$$t_m = \frac{770 \text{ kg/m}^3 \times 3 \text{ m} \left( 0.25 \times 0.25 \text{ m}^2 - \pi (0.025 \text{ m})^2 / 4 \right)}{7500 \text{ W}} 2.44 \times 10^5 \text{ J/kg} = 4660 \text{ s} = 1.29 \text{ h} <$$

Continued...

### PROBLEM 8.47 (Cont.)

(b) The effect of  $\dot{m}$  on  $q$  and  $T_{m,o}$  was determined by accessing the *Correlations* Toolpad of IHT, and the results are plotted as follows.

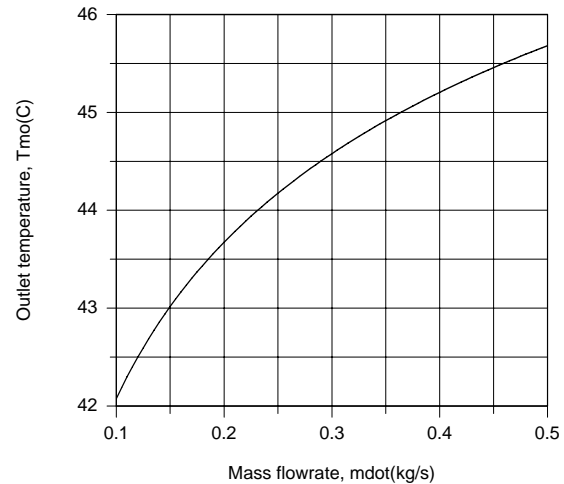
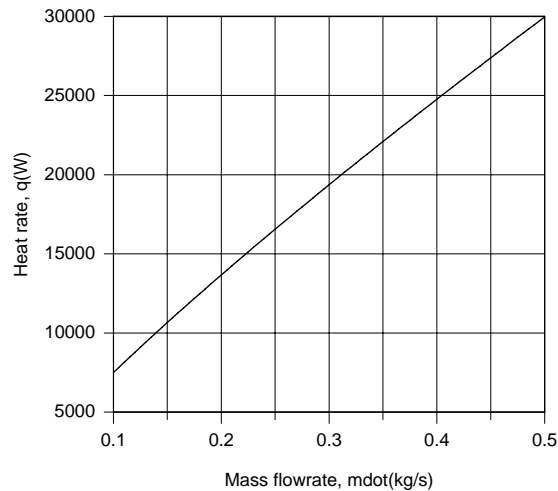

Although  $q$  increases with increasing  $\dot{m}$  due to the attendant increase in  $Re_D$ , and therefore  $\bar{h}$ , the increase is not linearly proportional to the change in  $\dot{m}$ . Hence, from the overall energy balance,  $q = \dot{m} c_p (T_{m,i} - T_{m,o})$ , there is a reduction in  $(T_{m,i} - T_{m,o})$ , which corresponds to an increase in  $T_{m,o}$ . With the increase in  $q$ , there is a reduction in  $t_m$ , and for  $\dot{m} = 0.5 \text{ kg/s}$ ,

$$t_m = 1167 \text{ s} = 0.324 \text{ h}$$

<

**COMMENTS:** Heat transfer from the water to the paraffin is also affected by free convection in the melt region around the tube. The effect is to decrease  $U$ , increase  $T_s$ , and decrease  $q$  with increasing time. The actual time to achieve complete melting would exceed values computed in the foregoing analysis.

## PROBLEM 8.48

**KNOWN:** Diameter and length of circular tube, liquid water flow rate, liquid water entrance temperatures and tube surface temperatures.

**FIND:** Water outlet temperatures for (a)  $T_{m,i} = 500 \text{ K}$ ,  $T_s = 510 \text{ K}$  and (b)  $T_{m,i} = 300 \text{ K}$ ,  $T_s = 310 \text{ K}$ . (c) Discuss whether the flow is laminar or turbulent for  $T_{m,i} = 300 \text{ K}$ ,  $T_s = 647 \text{ K}$ .

**SCHEMATIC:**

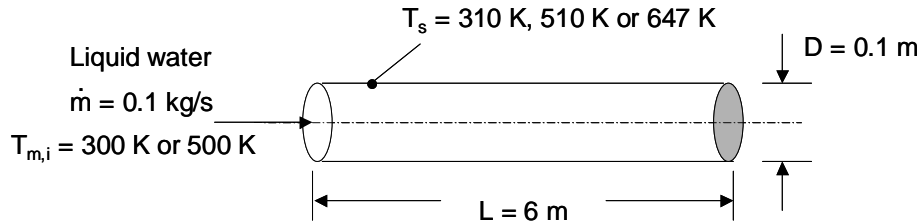

**ASSUMPTIONS:** (1) Steady-state conditions, (2) Constant properties in parts (a) and (b), (3) Negligible viscous dissipation.

**PROPERTIES:** Table A.6, liquid water ( $\bar{T}_m = 505 \text{ K}$ , assumed):  $\mu = 115.5 \times 10^{-6} \text{ N}\cdot\text{s}/\text{m}^2$ ,  $Pr = 0.855$ ,  $k = 0.635 \text{ W}/\text{m}\cdot\text{K}$ ,  $c_p = 4700 \text{ J}/\text{kg}\cdot\text{K}$ . Liquid water ( $\bar{T}_m = 305 \text{ K}$ , assumed):  $\mu = 769 \times 10^{-6} \text{ N}\cdot\text{s}/\text{m}^2$ ,  $Pr = 5.20$ ,  $k = 0.620 \text{ W}/\text{m}\cdot\text{K}$ ,  $c_p = 4178 \text{ J}/\text{kg}\cdot\text{K}$ .

**ANALYSIS:** (a) We begin by calculating the Reynolds number

$$Re_D = \frac{4\dot{m}}{\pi D \mu} = \frac{4 \times 0.1 \text{ kg/s}}{\pi \times 0.1 \text{ m} \times 115.5 \times 10^{-6} \text{ N}\cdot\text{s}/\text{m}^2} = 11,014$$

Therefore, the flow is in a fully turbulent condition. Since  $L/D = 6\text{m}/0.1\text{m} = 60$ , we conclude that entrance effects are not important. We may use Dittus-Boelter (Eq. 8.60) to determine the average heat transfer coefficient and the mean outlet temperature may be found from Eq. (8.41b).

$$\bar{h} = \frac{k}{D} \left[ 0.023 Re_D^{4/5} Pr^{0.4} \right] = \frac{0.635 \text{ W}/\text{m}\cdot\text{K}}{0.1 \text{ m}} \left[ 0.023 \times 11,014^{4/5} 0.855^{0.4} \right] = 235 \text{ W}/\text{m}^2 \cdot \text{K}$$

$$\begin{aligned} T_{m,o} &= T_s - (T_s - T_{m,i}) \exp\left(-\frac{PL}{\dot{m}c_p} \bar{h}\right) \\ &= 510 \text{ K} - 10 \text{ K} \times \exp\left(-\frac{\pi \times 0.1 \text{ m} \times 6 \text{ m}}{0.1 \text{ kg/s} \times 4700 \text{ J}/\text{kg}\cdot\text{K}} 235 \text{ W}/\text{m}^2 \cdot \text{K}\right) = 506.1 \text{ K} \end{aligned}$$

(b) The Reynolds number is

$$Re_D = \frac{4\dot{m}}{\pi D \mu} = \frac{4 \times 0.1 \text{ kg/s}}{\pi \times 0.1 \text{ m} \times 769 \times 10^{-6} \text{ N}\cdot\text{s}/\text{m}^2} = 1655$$

Continued...

### PROBLEM 8.48 (Cont.)

Therefore, the flow is laminar. The thermal entrance length is  $x_{fd,t} = 0.05 \times D \times Re_D \times Pr = 0.05 \times 0.1 \text{ m} \times 1655 \times 5.20 = 43.0 \text{ m} > L$ . Therefore, we expect entrance effects to be significant. With  $Pr > 5$ , we may use Eq. (8.57) with Eq. (8.56) for the Graetz number, to estimate the value of  $\bar{h}$ .

$$h = \frac{k}{D} \left\{ 3.66 + \frac{0.0668(D/L)Re_D Pr}{1 + 0.04[(D/L)Re_D Pr]^{2/3}} \right\}$$

$$= \frac{0.620 \text{ W/m} \cdot \text{K}}{0.1 \text{ m}} \left\{ 3.66 + \frac{0.0668(0.1 \text{ m}/6 \text{ m}) \times 1655 \times 5.20}{1 + 0.04[(0.1 \text{ m}/6.0 \text{ m}) \times 1655 \times 5.20]^{2/3}} \right\} = 51.0 \text{ W/m}^2 \cdot \text{K}$$

Using Eq. (8.41b)

$$T_{m,o} = T_s - (T_s - T_{m,i}) \exp\left(-\frac{PL}{\dot{m}c_p} \bar{h}\right)$$

$$= 310 \text{ K} - 10 \text{ K} \times \exp\left(-\frac{\pi \times 0.1 \text{ m} \times 6 \text{ m}}{0.1 \text{ kg/s} \times 4178 \text{ J/kg} \cdot \text{K}} 51 \text{ W/m}^2 \cdot \text{K}\right) = 302.1 \text{ K} \quad <$$

(c) The temperature variations within the water are very large. Therefore, properties are expected to vary significantly from location to location. Near the entrance of the tube, average temperatures will be low, and the flow is expected to be laminar. However, as the boundary layer regions grow, higher temperatures will exist in a greater portion of the liquid and viscosities may drop to very low values. Hence, the flow may trip into turbulent conditions at a location between the tube entrance and the tube exit. The assumption of constant properties under the conditions of part (c) may not be appropriate.

**COMMENTS:** Even though entrance effects are important for the laminar flow conditions of part (b), the heat transfer coefficient is small relative to that associated with the turbulent conditions of part (a).

### PROBLEM 8.49

**KNOWN:** Diameter, length and surface temperature of condenser tubes. Water velocity and inlet temperature.

**FIND:** (a) Water outlet temperature evaluating properties at  $T_m = 300$  K, (b) Repeat calculations using properties evaluated at the appropriate temperature,  $\bar{T}_m = (T_{m,i} + T_{m,o})/2$ , and (c) Coolant mean velocities for the range  $4 \leq L \leq 7$  m which provide the same  $T_{m,o}$  as found in part (b).

**SCHEMATIC:**

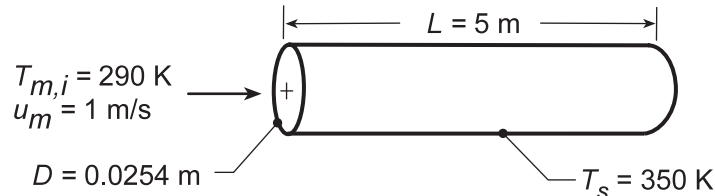

**ASSUMPTIONS:** (1) Negligible tube wall conduction resistance, (2) Incompressible liquid with negligible viscous dissipation.

**PROPERTIES:** Table A.6, Water ( $\bar{T}_m = 300$  K):  $\rho = 997$  kg/m<sup>3</sup>,  $c_p = 4179$  J/kg·K,  $\mu = 855 \times 10^{-6}$  kg/s·m,  $k = 0.613$  W/m·K,  $Pr = 5.83$ .

**ANALYSIS:** (a) From Equation 8.41b

$$T_{m,o} = T_s - (T_s - T_{m,i}) \exp \left[ - \left( \pi DL / \dot{m} c_p \right) \bar{h} \right].$$

and evaluating properties at  $\bar{T}_m = 300$  K, find

$$Re_D = \frac{\rho u_m D}{\mu} = \frac{997 \text{ kg/m}^3 (1 \text{ m/s}) (0.0254 \text{ m})}{855 \times 10^{-6} \text{ kg/s} \cdot \text{m}} = 29,618$$

The flow is turbulent, and since  $L/D = 197$ , it is reasonable to assume fully developed flow throughout the tube. Hence,  $\bar{h} \approx h_{fd}$ . From the Dittus-Boelter equation,

$$Nu_D = 0.023 Re_D^{4/5} Pr^{0.4} = 0.023 (29,618)^{4/5} (5.83)^{0.4} = 176$$

$$\bar{h} = Nu_D (k/D) = 176 (0.613 \text{ W/m} \cdot \text{K} / 0.0254 \text{ m}) = 4248 \text{ W/m}^2 \cdot \text{K}.$$

With

$$\dot{m} = \rho u_m \left( \pi D^2 / 4 \right) = (\pi/4) 997 \text{ kg/m}^3 (1 \text{ m/s}) (0.0254 \text{ m})^2 = 0.505 \text{ kg/s}.$$

Equation 8.41b yields

$$T_{m,o} = 350 \text{ K} - (60 \text{ K}) \exp \left[ - \frac{\pi (0.0254 \text{ m}) 5 \text{ m} (4248 \text{ W/m}^2 \cdot \text{K})}{0.505 \text{ kg/s} (4179 \text{ J/kg} \cdot \text{K})} \right] = 323 \text{ K} = 50^\circ \text{C} \quad <$$

(b) Using the *IHT Correlations Tool, Internal Flow*, for fully developed *Turbulent Flow*, along with the energy balance and rate equations above, the calculation of part (a) is repeated with  $\bar{T}_m = (T_{m,i} + T_{m,o})/2$  giving these results:

$$\bar{T}_m = 307.3 \text{ K} \quad T_{m,o} = 51.7^\circ \text{C} = 324.7 \text{ K} \quad <$$

(c) Using the IHT model developed for the part (b) analysis, the coolant mean velocity,  $u_m$ , as a function of tube length  $L$  with  $T_{m,o} = 51.7^\circ \text{C}$  is calculated and the results plotted below.

Continued...



### PROBLEM 8.49 (Cont.)

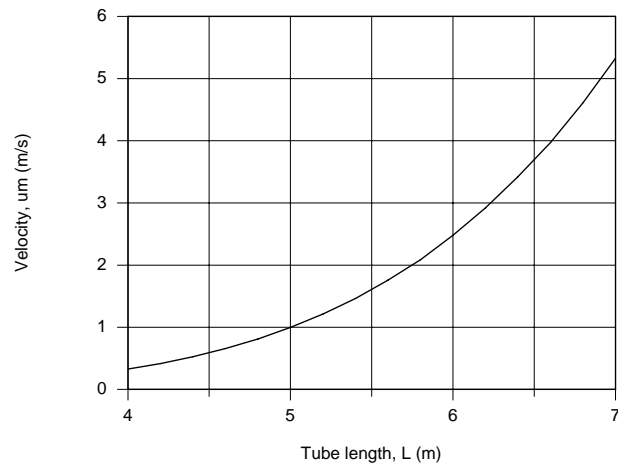

**COMMENTS:** (1) Using  $\bar{T}_m = 300$  K vs.  $\bar{T}_m = (T_{m,i} + T_{m,o})/2 = 307$  K for this application resulted in a difference of  $T_{m,o} = 50^\circ\text{C}$  vs.  $T_{m,o} = 51.7^\circ\text{C}$ . While the difference is only  $1.7^\circ\text{C}$ , it is good practice to use the proper value for  $\bar{T}_m$ .

(2) Note that  $u_m$  must be increased markedly with increasing length in order that  $T_{m,o}$  remain fixed.

## PROBLEM 8.50

**KNOWN:** Gas turbine vane approximated as a tube of prescribed diameter and length maintained at a known surface temperature. Air inlet temperature and flowrate.

**FIND:** (a) Outlet temperature of the air coolant for the prescribed conditions and (b) Compute and plot the air outlet temperature  $T_{m,o}$  as a function of flow rate,  $0.1 \leq \dot{m} \leq 0.6$  kg/h. Compare this result with those for vanes having passage diameters of 2 and 4 mm.

**SCHEMATIC:**

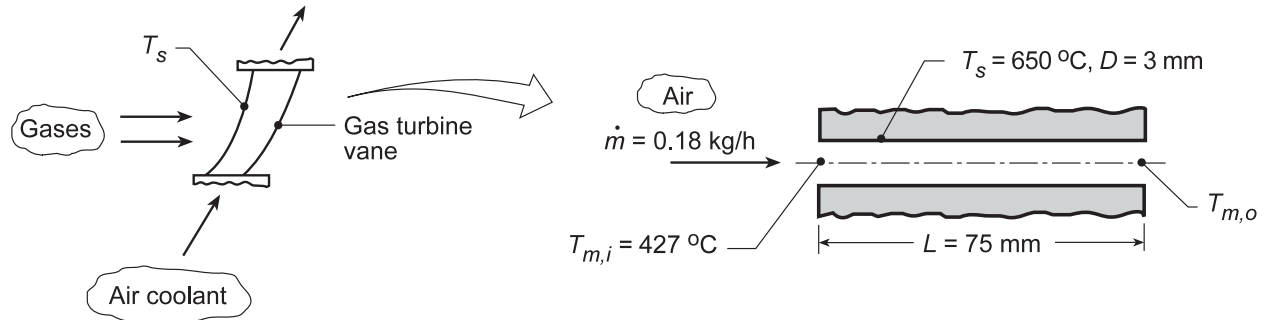

**ASSUMPTIONS:** (1) Steady-state conditions, (2) Ideal gas with negligible viscous dissipation and pressure variation.

**PROPERTIES:** Table A.4, Air (assume  $\bar{T}_m = 780$  K, 1 atm):  $c_p = 1094$  J/kg·K,  $k = 0.0563$  W/m·K,  $\mu = 363.7 \times 10^{-7}$  N·s/m<sup>2</sup>,  $Pr = 0.706$ .

**ANALYSIS:** (a) For constant wall temperature heating, from Eq. 8.41b,

$$\frac{T_s - T_{m,o}}{T_s - T_{m,i}} = \exp\left(-\frac{PL\bar{h}}{\dot{m}c_p}\right) \quad (1)$$

where  $P = \pi D$ . For flow in a circular passage,

$$Re_D = \frac{4\dot{m}}{\pi D\mu} = \frac{4 \times 0.18 \text{ kg/h} (1/3600 \text{ s/h})}{\pi (0.003 \text{ m}) 363.7 \times 10^{-7} \text{ N}\cdot\text{s}/\text{m}^2} = 584. \quad (2)$$

The flow is laminar, and from Eq. 8.3,  $x_{fd,h} = 0.05 Re_D D = 88$  mm. Thus, the flow is in the combined entry length. From Eq. 8.56,  $Gz_D = (D/L) Re_D Pr = 16.5$  and from Eq. 8.58,

$$\overline{Nu}_D = \frac{\bar{h}D}{k} = \frac{3.66}{\tanh[2.264 Gz_D^{-1/3} + 1.7 Gz_D^{-2/3}]} + \frac{0.0499 Gz_D \tanh(Gz_D^{-1})}{\tanh(2.432 Pr^{1/6} Gz_D^{-1/6})} \quad (3)$$

$$\bar{h} = \frac{0.0563 \text{ W/m}\cdot\text{K}}{0.003 \text{ m}} \left( \frac{\frac{3.66}{\tanh[2.264 \times 16.5^{-1/3} + 1.7 \times 16.5^{-2/3}]} + 0.0499 \times 16.5 \tanh(16.5^{-1})}{\tanh(2.432 \times 0.706^{1/6} \times 16.5^{-1/6})} \right) = 95.0 \text{ W/m}^2 \cdot \text{K}$$

Hence, the air outlet temperature is

$$\frac{650 - T_{m,o}}{(650 - 427)^\circ \text{C}} = \exp\left(-\frac{\pi (0.003 \text{ m}) \times 0.075 \text{ m} \times 95.0 \text{ W/m}^2 \cdot \text{K}}{(0.18/3600) \text{ kg/s} \times 1094 \text{ J/kg}\cdot\text{K}}\right)$$

$$T_{m,o} = 585^\circ \text{C}$$

<

Continued...

### PROBLEM 8.50 (Cont.)

(b) Using the *IHT Correlations Tool, Internal Flow, for Laminar Flow with combined entry length*, along with the energy balance and rate equations above, the outlet temperature  $T_{m,o}$  was calculated as a function of flow rate for diameters of  $D = 2, 3$  and  $4$  mm. The plot below shows that  $T_{m,o}$  decreases strongly with increasing flow rate, but is independent of passage diameter.

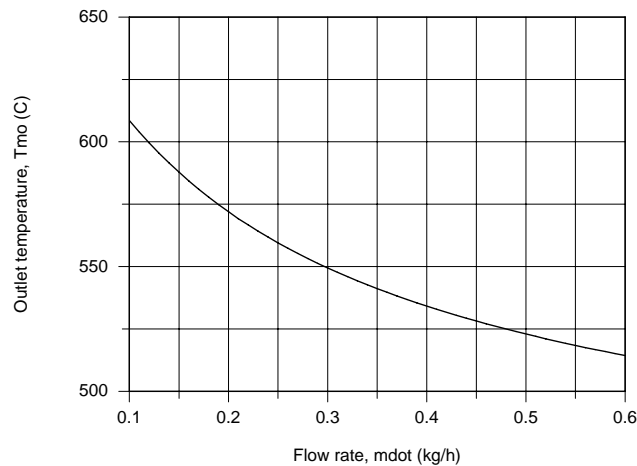

**COMMENTS:** (1) Based upon the calculation for  $T_{m,o} = 585^\circ\text{C}$ ,  $\bar{T}_m = 779$  K which is in good agreement with our assumption to evaluate the thermophysical properties. (2) Why is  $T_{m,o}$  independent of  $D$ ? Since  $Re_D$  varies inversely with  $D$ ,  $Gz_D$  is independent of  $D$ , and so is  $Nu_D$ . From Eq. (3), note that  $\bar{h}$  is inversely proportional to  $D$ ,  $\bar{h} \sim D^{-1}$ . From Eq. (1), note that on the right-hand side the product  $P \cdot \bar{h}$  will be independent of  $D$ . Hence,  $T_{m,o}$  will depend only on the mass flow rate. This is, of course, a consequence of the laminar flow condition and will not be the same for turbulent flow.

## PROBLEM 8.51

**KNOWN:** Gas-cooled nuclear reactor tube of 20 mm diameter and 780 mm length with helium heated from 600 K to 1000 K at  $8 \times 10^{-3}$  kg/s.

**FIND:** (a) Uniform tube wall temperature required to heat the helium, (b) Outlet temperature and required flow rate to achieve same removal rate and wall temperature if the coolant gas is air.

**SCHEMATIC:**

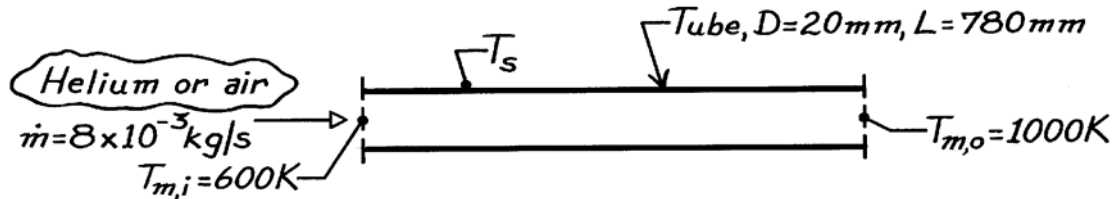

**ASSUMPTIONS:** (1) Steady-state conditions, (2) Ideal gas with negligible viscous dissipation and pressure variation, (3) Fully developed conditions.

**PROPERTIES:** Table A-4, Helium ( $\bar{T}_m = 800\text{K}$ , 1 atm):  $\rho = 0.06272 \text{ kg/m}^3$ ,  $c_p = 5193 \text{ J/kg}\cdot\text{K}$ ,  $k = 0.304 \text{ W/m}\cdot\text{K}$ ,  $\mu = 382 \times 10^{-7} \text{ N}\cdot\text{s/m}^2$ ,  $\nu = 6.39 \times 10^{-4} \text{ m}^2/\text{s}$ ,  $\text{Pr} = 0.654$ ; Air ( $\bar{T}_m = 800\text{K}$ , 1 atm):  $\rho = 0.4354 \text{ kg/m}^3$ ,  $c_p = 1099 \text{ J/kg}\cdot\text{K}$ ,  $k = 57.3 \times 10^{-3} \text{ W/m}\cdot\text{K}$ ,  $\nu = 84.93 \times 10^{-6} \text{ m}^2/\text{s}$ ,  $\text{Pr} = 0.709$ .

**ANALYSIS:** (a) For helium and a constant wall temperature, from Eq. 8.41b,

$$\frac{T_s - T_{m,o}}{T_s - T_{m,i}} = \exp\left(-\frac{PL\bar{h}}{\dot{m} c_p}\right)$$

where  $P = \pi D$ . For the circular tube,

$$\text{Re}_D = \frac{4\dot{m}}{\pi D\mu} = \frac{4 \times 8 \times 10^{-3} \text{ kg/s}}{\pi \times 0.020 \text{ m} \times 382 \times 10^{-7} \text{ N}\cdot\text{s/m}^2} = 1.333 \times 10^4$$

and using the Dittus-Boelter correlation for turbulent, fully developed flow,

$$\text{Nu} = 0.023 \text{Re}_D^{4/5} \text{Pr}^{0.4} = 0.023 (1.333 \times 10^4)^{4/5} (0.654)^{0.4} = 38.7$$

$$h = \text{Nu} \cdot k/D = 38.7 \times 0.304 \text{ W/m}\cdot\text{K} / 0.02 \text{ m} = 588 \text{ W/m}^2 \cdot \text{K}.$$

Hence, the surface temperature is

$$\frac{T_s - 1000 \text{ K}}{T_s - 600 \text{ K}} = \exp\left[-\frac{\pi (0.020 \text{ m}) \times 0.780 \text{ m} \times 588 \text{ W/m}^2 \cdot \text{K}}{8 \times 10^{-3} \text{ kg/s} \times 5193 \text{ J/kg}\cdot\text{K}}\right] = 0.500$$

$$T_s = 1400 \text{ K}.$$

The heat rate with helium coolant is

$$q = \dot{m} c_p (T_{m,o} - T_{m,i}) = 8 \times 10^{-3} \text{ kg/s} \times 5193 \text{ J/kg}\cdot\text{K} (1000 - 600) \text{ K} = 16.62 \text{ kW}.$$

Continued ...

**PROBLEM 8.51 (Cont.)**

(b) For the same heat removal rate ( $q$ ) and wall temperature ( $T_s$ ) with air supplied at  $T_{m,i}$ , the relevant relations are

$$q = 16,620 \text{ W} = \dot{m}_a c_p (T_{m,o} - T_{m,i}) \quad (1)$$

$$\frac{T_s - T_{m,o}}{T_s - T_{m,i}} = \exp\left[-\frac{PL\bar{h}_a}{\dot{m}_a c_p}\right] \quad (2)$$

$$\text{Re} = \frac{4\dot{m}_a}{\pi D\mu} \quad \frac{\bar{h}D}{k} = 0.023 \text{Re}_D^{4/5} \text{Pr}^{0.4} \quad (3,4)$$

where  $T_{m,o}$  and  $\dot{m}$  are unknown. An iterative solution is required: assume a value of  $T_{m,o}$  and find  $\dot{m}$  from Eq. (1); use  $\dot{m}$  in Eqs. (3) and (4) to find  $\bar{h}$  and then Eq. (2) to evaluate  $T_{m,o}$ ; compare results and iterate. Using thermophysical properties of air evaluated at  $\bar{T}_m = 800\text{K}$ , the above relations, written in the order they would be used in the iteration, become

$$\dot{m}_a = \frac{15.1}{T_{m,o} - 600} \quad (5)$$

$$\bar{h}_a = 5600\dot{m}_a^{4/5} \quad (6)$$

$$T_{m,o} = 1400 \text{ K} - 800 \text{ K} \times \exp\left[-4.459 \times 10^{-5} (\bar{h}_a / \dot{m}_a)\right] \quad (7)$$

Results of the iterative solution are

Trial	$T_{m,o}$ (K) (Assumed)	$\dot{m}$ (kg/s) Eq. (5)	$\bar{h}_a$ ( $\text{W}/\text{m}^2 \cdot \text{K}$ ) Eq. (6)	$T_{m,o}$ (K) Eq. (7)
1	1000	$3.781 \times 10^{-2}$	407	905
2	950	$4.321 \times 10^{-2}$	453	899
3	900	$5.041 \times 10^{-2}$	513	891
4	890	$5.215 \times 10^{-2}$	527	890

Hence, we find

$$\dot{m}_a = 5.22 \times 10^{-2} \text{ kg/s} \quad T_{m,o} = 890 \text{ K.} \quad \leftarrow$$

**COMMENTS:** To achieve the same cooling rate with air, the required mass rate is 6.5 times that obtained with helium.

### PROBLEM 8.52

**KNOWN:** Air at prescribed inlet temperature and mean velocity heated by condensing steam on its outer surface.

**FIND:** (a) Air outlet temperature, pressure drop and heat transfer rate and (b) Effect on parameters of part (a) if pressure were doubled.

**SCHEMATIC:**

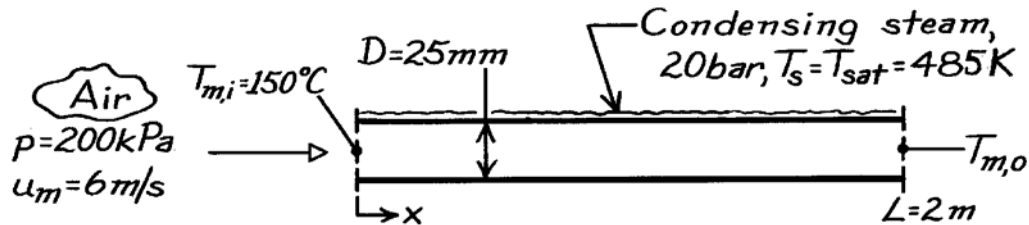

**ASSUMPTIONS:** (1) Steady-state conditions, (2) Negligible kinetic and potential energy changes, (3) Thermal resistance of tube wall and condensate film are negligible.

**PROPERTIES:** Table A-4, Air (assume  $\bar{T}_m = 450$  K, 1 atm = 101.3 kPa):  $\rho = 0.7740$  kg/m<sup>3</sup>,  $c_p = 1021$  J/kg·K,  $\mu = 250.7 \times 10^{-7}$  N·s/m<sup>2</sup>,  $k = 0.0373$  W/m·K,  $Pr = \mu c_p / k = 0.686$ . Note that only  $\rho$  is pressure dependent; i.e.,  $\rho \propto p$ ; Table A-6, Saturated water (20 bar):  $T_{sat} = T_s = 485$  K.

**ANALYSIS:** (a) For constant wall temperature heating, from Eq. 8.41b,

$$\frac{T_s - T_{m,o}}{T_s - T_{m,i}} = \exp\left(-\frac{PL}{\dot{m} c_p} \bar{h}_i\right)$$

where  $P = \pi D$ . For the air flow, find the mass rate and Reynolds number,

$$\dot{m} = \rho A_c u_m = 0.7740 \text{ kg/m}^3 (200 \text{ kPa}/101.3 \text{ kPa}) \left(\pi (0.025 \text{ m})^2 / 4\right) \times 6 \text{ m/s}$$

$$\dot{m} = 4.501 \times 10^{-3} \text{ kg/s.}$$

$$Re_D = \frac{4\dot{m}}{\mu \pi D} = \frac{4 \times 4.501 \times 10^{-3} \text{ kg/s}}{250.7 \times 10^{-7} \text{ N}\cdot\text{s/m}^2 \times \pi (0.025 \text{ m})} = 9.143 \times 10^3.$$

Using the Dittus-Boelter correlation for fully-developed turbulent flow,

$$Nu_D = 0.023 Re^{4/5} Pr^{0.4} = 0.023 (9.143 \times 10^3)^{4/5} (0.682)^{0.4} = 29.12$$

$$h_i = Nu \cdot k / D = 29.12 \times 0.0373 \text{ W/m}\cdot\text{K} / 0.025 \text{ m} = 43.4 \text{ W/m}^2 \cdot \text{K}.$$

Hence, the outlet temperature is

$$\frac{212 - T_{m,o}}{(212 - 150)^\circ \text{C}} = \exp\left[-\frac{\pi (0.025 \text{ m}) \times 2 \text{ m} \times 43.4 \text{ W/m}^2 \cdot \text{K}}{4.501 \times 10^{-3} \text{ kg/s} \times 1021 \text{ J/kg}\cdot\text{K}}\right]$$

$$T_{m,o} = 198^\circ \text{C.}$$

<

Continued ...

**PROBLEM 8.52 (Cont.)**

The pressure drop follows from Eqs. 8.21 and 8.22,

$$f = (0.790 \ln(\text{Re}_D) - 1.64)^{-2} = \left(0.790 \ln(9.143 \times 10^3) - 1.64\right)^{-2} = 0.0323$$

$$\Delta p = f \frac{\rho u_m^2}{2D} L$$

$$\Delta p = 0.0323 \frac{0.7740 \text{ kg/m}^3 (200/101.3) (6 \text{ m/s})^2 \times 2 \text{ m}}{2 \times 0.025 \text{ m}} = 71.1 \text{ N/m}^2. \quad <$$

The heat transfer rate is

$$q = \dot{m} c_p (T_{m,o} - T_{m,i}) = 4.501 \times 10^{-3} \text{ kg/s} \times 1021 \text{ J/kg} \cdot \text{K} (198 - 150) \text{ K} = 221 \text{ W}. \quad <$$

(b) If the pressure were doubled, we can see from the above relations that  $\dot{m} \propto p$  hence

$$\dot{m} = 2\dot{m}_o$$

$$\text{Re}_D = 2\text{Re}_{D,o},$$

since

$$h_i \propto (\text{Re})^{4/5} \rightarrow (h_i / h_{i,o}) = 2^{4/5},$$

$$h_i = 1.74 h_{i,o}.$$

It follows that  $T_{m,o} = 195^\circ\text{C}$ , so that the effect on temperature is slight. However, the pressure drop increases by the factor 1.68 and the heat rate by the factor 1.88. In summary:

Parameter	p = 200 kPa Part (a)	p = 400 kPa Part (b)	Increase, %
$\dot{m}$ , kg/s $\times 10^3$	4.501	9.002	100
$h_i$ , W/m <sup>2</sup> ·K	43.4	75.6	74
$T_{m,o} - T_{m,i}$ , °C	48	45	-6
$\Delta p$ , N/m <sup>2</sup>	71.1	119	68
q, W	221	415	88

**COMMENTS:** (1) Note that  $\bar{T}_m = (198 + 150)^\circ\text{C}/2 = 447 \text{ K}$  agrees well with the assumed value (450 K) used to evaluate the thermophysical properties.

### PROBLEM 8.53

**KNOWN:** Diameter, length and surface temperature of tubes used to heat ambient air. Flow rate and inlet temperature of air.

**FIND:** (a) Air outlet temperature and heat rate per tube, (b) Effect of flow rate on outlet temperature. Design and operating conditions suitable for providing 1 kg/s of air at 75°C.

**SCHEMATIC:**

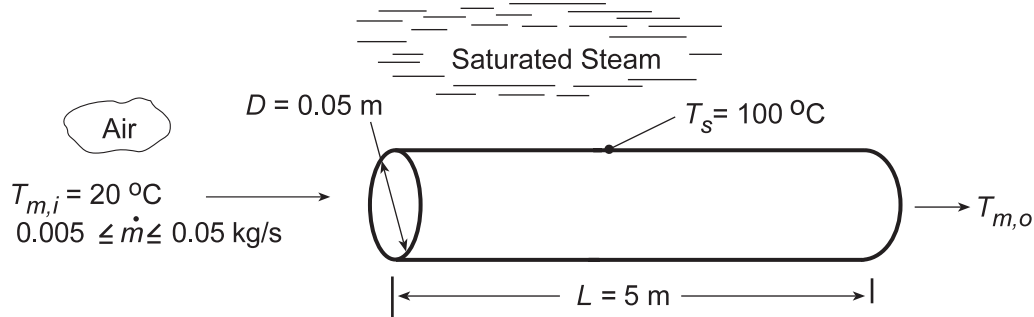

**ASSUMPTIONS:** (1) Steady-state, (2) Ideal gas with negligible viscous dissipation and pressure variation, (3) Negligible tube wall thermal resistance.

**PROPERTIES:** Table A.4, air (assume  $\bar{T}_m = 330$  K):  $c_p = 1008$  J/kg·K,  $\mu = 198.8 \times 10^{-7}$  N·s/m<sup>2</sup>,  $k = 0.0285$  W/m·K, Pr = 0.703.

**ANALYSIS:** (a) For  $\dot{m} = 0.01$  kg/s,  $Re_D = 4\dot{m}/\pi D\mu = 0.04$  kg/s/ $\pi(0.05$  m) $198.8 \times 10^{-7}$  N·s/m<sup>2</sup> = 12,810. Hence, the flow is turbulent. If fully developed flow is assumed throughout the tube, the Dittus-Boelter correlation may be used to obtain the average Nusselt number.

$$\bar{Nu}_D \approx Nu_D = 0.023 Re_D^{4/5} Pr^{0.4} = 0.023(12,810)^{0.8} (0.703)^{0.4} = 38.6$$

Hence,  $\bar{h} = \bar{Nu}_D (k/D) = 38.6(0.0285$  W/m·K/ $0.05$  m) =  $22.0$  W/m<sup>2</sup>·K

From Eq. 8.41b,

$$\frac{T_s - T_{m,o}}{T_s - T_{m,i}} = \exp\left(-\frac{\pi DL\bar{h}}{\dot{m}c_p}\right) = \exp\left(-\frac{\pi \times 0.05 \text{ m} \times 5 \text{ m} \times 22 \text{ W/m}^2 \cdot \text{K}}{0.01 \text{ kg/s} \times 1008 \text{ J/kg} \cdot \text{K}}\right) = 0.180$$

$$T_{m,o} = T_s - 0.180(T_s - T_{m,i}) = 100^\circ\text{C} - 0.180(80^\circ\text{C}) = 85.6^\circ\text{C} \quad <$$

Hence,  $q = \dot{m}c_p(T_{m,o} - T_{m,i}) = 0.01$  kg/s( $1008$  J/kg·K) $65.6$  K =  $661$  W <

(b) The effect of flow rate on the outlet temperature was determined by using the IHT *Correlations and Properties* Toolpads.

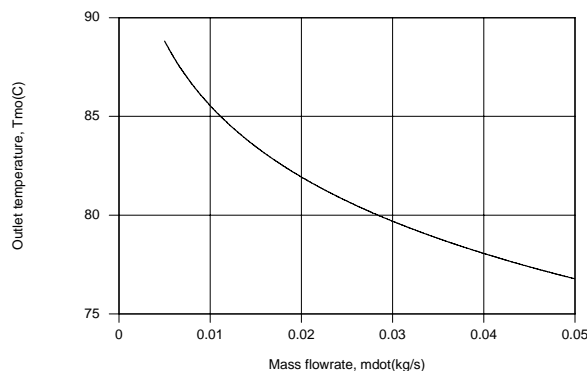

Continued...



### PROBLEM 8.53 (Cont.)

Although  $\bar{h}$  and hence the heat rate increase with increasing  $\dot{m}$ , the increase in  $q$  is not linearly proportional to the increase in  $\dot{m}$  and  $T_{m,o}$  decreases with increasing  $\dot{m}$ .

A flow rate of  $\dot{m} = 0.05 \text{ kg/s}$  is not large enough to provide the desired outlet temperature of  $75^\circ\text{C}$ , and to achieve this value, a flow rate of  $0.0678 \text{ kg/s}$  would be needed. At such a flow rate,  $N = 1 \text{ kg/s} / 0.0678 \text{ kg/s} = 14.75 \approx 15$  tubes would be needed to satisfy the process air requirement. Alternatively, a lower flow rate could be supplied to a larger number of tubes and the discharge mixed with ambient air to satisfy the desired conditions. Requirements of this option are that

$$N\dot{m} + \dot{m}_{\text{amb}} = 1 \text{ kg/s}$$

$$(N\dot{m} + \dot{m}_{\text{amb}})c_p(T_{m,o} - T_{m,i}) = 1 \text{ kg/s} \times 1008 \text{ J/kg} \cdot \text{K} (75 - 20) \text{ K} = 55,400 \text{ W}$$

where  $\dot{m}$  is the flow rate per tube. Using a larger number of tubes with a smaller flow rate per tube would reduce flow pressure losses and hence provide for reduced operating costs.

**COMMENTS:** With  $L/D = 5 \text{ m} / 0.05 \text{ m} = 100$ , the assumption of fully developed conditions throughout the tube is reasonable.

## PROBLEM 8.54

**KNOWN:** Length of a tube with constant surface temperature and a combined entrance length,  $L < x_{fd,t}$ .

**FIND:** Expression for the ratio of the average heat transfer coefficient for  $N$  tubes each of length  $L_N = L/N$  to the average coefficient for the single tube.

**SCHEMATIC:**

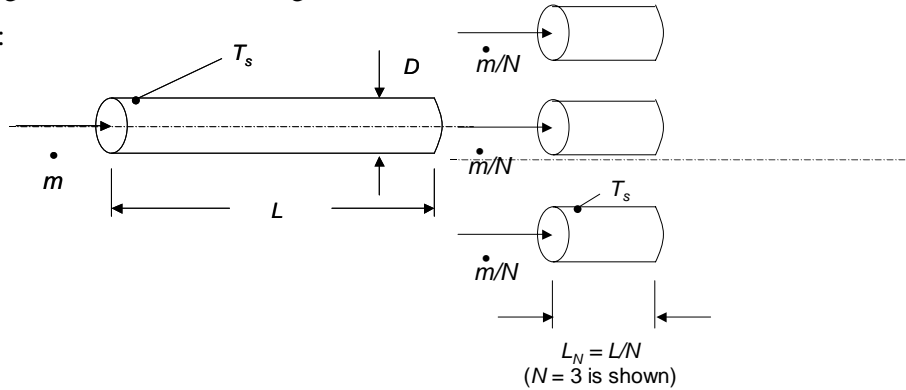

**ASSUMPTIONS:** (1) Combined entrance conditions, (2) Constant properties, (3) Negligible viscous dissipation.

**PROPERTIES:** Given:  $Pr = 4$ .

**ANALYSIS:** The Nusselt number for the combined entrance problem with  $0.1 < Pr < 5$  is given by Equation 8.58 and is seen to be a function of the Graetz number,  $Gz_D = DRe_DPr/L$ , and the Prandtl number,  $Pr$ . For multiple tubes, each of length  $L_N = L/N$  with a flowrate of  $\dot{m}_N = \dot{m} / N$ , observe that  $Re_{D,N} = Re_{D,1}/N$ , resulting in

$$Gz_{D,N} = DRe_{D,N}Pr/L_N = DRe_{D,1}Pr/L = Gz_{D,1}$$

Since the Graetz number is unchanged, and  $Pr$  has been specified as constant, the Nusselt number is unchanged. With  $h = Nu_D k/D$ ,

$$\bar{h}_{D,N} / \bar{h}_{D,1} = 1 \quad <$$

**COMMENTS:** (1) Breaking the tube into shorter lengths has no impact on the overall heat transfer rate. Shortening the tube will, in general, tend to increase the average heat transfer coefficient, but this effect is offset by reduction of the flow rate in each of the shorter tubes. The scheme would not result in any heat transfer *enhancement*. (2) The same result holds for the thermal entrance problem, since the Nusselt number is also a function only of  $Gz_D$ .

## PROBLEM 8.55

**KNOWN:** Configuration of microchannel heat sink.

**FIND:** (a) Expressions for longitudinal distributions of fluid mean and surface temperatures, (b) Coolant and channel surface temperature distributions for prescribed conditions, (c) Effect of heat sink design and operating conditions on the chip heat flux for a prescribed maximum allowable surface temperature.

**SCHEMATIC:**

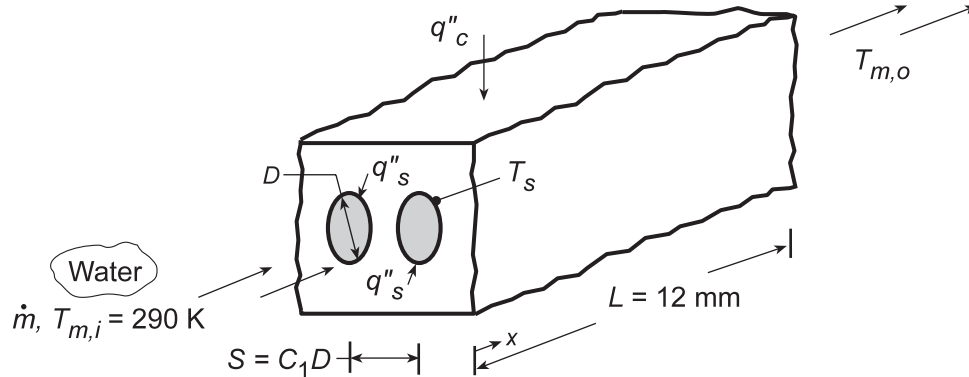

**ASSUMPTIONS:** (1) Steady-state, (2) Incompressible liquid with negligible viscous dissipation, (3) All of the chip power dissipation is transferred to the coolant, with a uniform surface heat flux,  $q''_s$ , (4) Laminar, fully developed flow, (5) Constant properties.

**PROPERTIES:** Table A.6, Water (assume  $\bar{T}_m = T_{m,i} = 290$  K):  $c_p = 4184$  J/kg·K,  $\mu = 1080 \times 10^{-6}$  N·s/m<sup>2</sup>,  $k = 0.598$  W/m·K,  $Pr = 7.56$ .

**ANALYSIS:** (a) The number of channels passing through the heat sink is  $N = L/S = L/C_1D$ , and conservation of energy dictates that

$$q''_c L^2 = N(\pi DL)q''_s = \pi L^2 q''_s / C_1$$

which yields

$$q''_s = \frac{C_1 q''_c}{\pi} \quad (1)$$

With the mass flowrate per channel designated as  $\dot{m}_1 = \dot{m}/N$ , Eqs. 8.40 and 8.27 yield

$$T_m(x) = T_{m,i} + \frac{q''_s \pi D}{\dot{m}_1 c_p} x = T_{m,i} + \frac{L q''_c}{\dot{m} c_p} x \quad (2) <$$

$$T_s(x) = T_m(x) + \frac{q''_s}{h} = T_m(x) + \frac{C_1 q''_c}{\pi h} \quad (3) <$$

where, for laminar, fully developed flow with uniform  $q''_s$ , Eq. 8.53 yields  $h = 4.36$  k/D.

(b) With  $L = 12$  mm,  $D = 1$  mm,  $C_1 = 2$  and  $\dot{m} = 0.01$  kg/s, it follows that  $S = 2$  mm,  $N = 6$  and  $Re_D = 4\dot{m}_1/\pi D\mu = 4(0.01 \text{ kg/s})/6\pi(0.001 \text{ m})1.08 \times 10^{-3} \text{ N}\cdot\text{s}/\text{m}^2 = 1965$ . Hence, the flow is laminar, as assumed, and  $h = 4.36(0.598 \text{ W/m}\cdot\text{K}/0.001 \text{ m}) = 2607 \text{ W/m}^2\cdot\text{K}$ . From Eqs. (2) and (3) the outlet mean and surface temperatures are

$$T_{m,o} = 290 \text{ K} + \frac{(0.012 \text{ m})^2 20 \times 10^4 \text{ W}/\text{m}^2}{0.01 \text{ kg/s}(4184 \text{ J/kg}\cdot\text{K})} = 290.7 \text{ K} = 17.7^\circ \text{C}$$

$$T_{s,o} = T_{m,o} + \frac{2}{\pi} \times \frac{20 \times 10^4 \text{ W}/\text{m}^2}{2607 \text{ W}/\text{m}^2\cdot\text{K}} = 339.5 \text{ K} = 66.5^\circ \text{C}$$

Continued...

## PROBLEM 8.55 (Cont.)

The axial temperature distributions are as follows

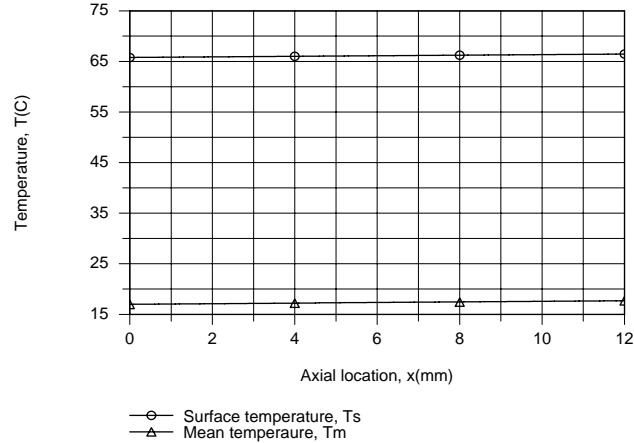

The flowrate is sufficiently large (and the convection coefficient sufficiently low) to render the increase in  $T_m$  and  $T_s$  with increasing  $x$  extremely small.

(c) The desired constraint of  $T_{s,max} \leq 50^\circ\text{C}$  is not met by the foregoing conditions. An obvious and logical approach to achieving improved performance would involve increasing  $\dot{m}_1$  such that turbulent flow is maintained in each channel. A value of  $\dot{m}_1 > 0.002 \text{ kg/s}$  would provide  $Re_D > 2300$  for  $D = 0.001$ . Using Eq. 8.60 with  $n = 0.4$  to evaluate  $Nu_D$  and accessing the Correlations Toolpad of IHT to explore the effect of variations in  $\dot{m}_1$  for different combinations of  $D$  and  $C_1$ , the following results were obtained.

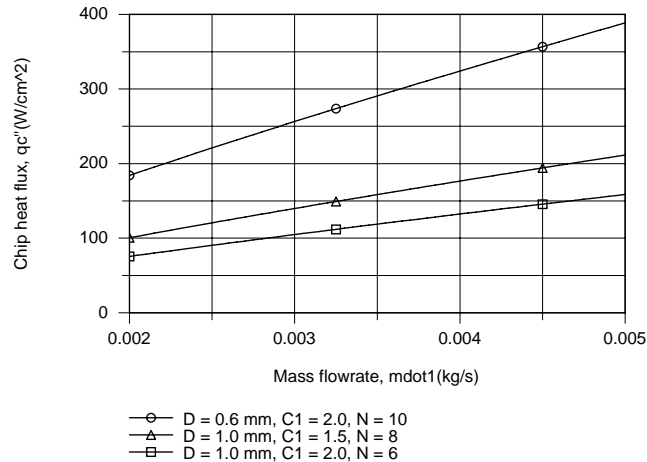

We first note that a significant increase in  $q_c''$  may be obtained by operating the channels in turbulent flow. In addition, there is an obvious advantage to reducing  $C_1$ , thereby increasing the number of channels for a fixed channel diameter. The biggest enhancement is associated with reducing the channel diameter, which significantly increases the convection coefficient, as well as the number of channels for fixed  $C_1$ . For  $\dot{m}_1 = 0.005 \text{ kg/s}$ ,  $h$  increases from  $32,400$  to  $81,600 \text{ W/m}^2\cdot\text{K}$  with decreasing  $D$  from  $1.0$  to  $0.6 \text{ mm}$ . However, for fixed  $\dot{m}_1$ , the mean velocity in a channel increases with decreasing  $D$  and care must be taken to maintain the flow pressure drop within acceptable limits.

**COMMENTS:** Although the distribution computed for  $T_m(x)$  in part (b) is correct, the distribution for  $T_s(x)$  represents an upper limit to actual conditions due to the assumption of fully developed flow throughout the channel.

## PROBLEM 8.56

**KNOWN:** Cold plate geometry and temperature. Inlet temperature and flow rate of water. Number of circuit boards and temperature and velocity of air in parallel flow over boards.

**FIND:** (a) Heat dissipation by cold plates, (b) Heat dissipation by air flow.

**SCHEMATIC:**

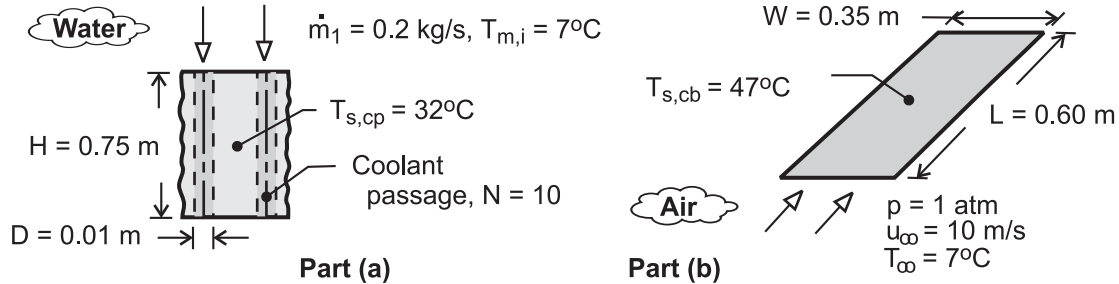

**ASSUMPTIONS:** (1) Isothermal cold plate, (2) All heated generated by circuit boards is dissipated by cold plates (Part (a)), (3) Circuit boards may be represented as isothermal at an average surface temperature, (4) Air flow over circuit boards approximates that over a flat plate in parallel flow, (5) Steady operation, (6) Constant properties, (7) Water is incompressible liquid with negligible viscous dissipation.

**PROPERTIES:** Table A-6, Water ( $\bar{T}_m \approx 290\text{K}$ ):  $c_p = 4184\text{ J/kg}\cdot\text{K}$ ,  $\mu = 1080 \times 10^{-6}\text{ N}\cdot\text{s/m}^2$ ,  $k = 0.598\text{ W/m}\cdot\text{K}$ ,  $\text{Pr} = 7.56$ . Table A-4, Air ( $p = 1\text{ atm}$ ,  $T_f = 300\text{K}$ ):  $\nu = 15.89 \times 10^{-6}\text{ m}^2/\text{s}$ ,  $k = 0.0263\text{ W/m}\cdot\text{K}$ ,  $\text{Pr} = 0.707$ .

**ANALYSIS:** (a) With  $\text{Re}_D = 4\dot{m}_1 / \pi D \mu = 4 \times 0.2\text{ kg/s} / \pi \times 0.01\text{m} \times 1080 \times 10^{-6}\text{ N}\cdot\text{s/m}^2 = 23,600$ , the flow is turbulent, and from Eq. (8.60),

$$h = \frac{k}{D} \text{Nu}_D = 0.023 \frac{k}{D} \text{Re}_D^{4/5} \text{Pr}^{0.4} = \frac{0.023 \times 0.598\text{ W/m}\cdot\text{K}}{0.01\text{m}} (23,600)^{4/5} (7.56)^{0.4} = 9,730\text{ W/m}^2\cdot\text{K}$$

With  $H/D = 0.75/0.01 = 75$ , it is reasonable to assume fully developed flow throughout the tube. Hence, from Eqs. (8.41b) and (8.34)

$$\frac{T_{s,cp} - T_{m,o}}{T_{s,cp} - T_{m,i}} = \exp\left(-\frac{\pi D H}{\dot{m}_1 c_p} h\right) = \exp\left(-\frac{\pi \times 0.01\text{m} \times 0.75\text{m} \times 9730\text{ W/m}^2\cdot\text{K}}{0.2\text{ kg/s} \times 4184\text{ J/kg}\cdot\text{K}}\right) = 0.760$$

$$T_{m,o} = T_{s,cp} - 0.76(T_{s,cp} - T_{m,i}) = 13^\circ\text{C}$$

$$q_1 = \dot{m}_1 c_p (T_{m,o} - T_{m,i}) = 0.2\text{ kg/s} \times 4184\text{ J/kg}\cdot\text{K} \times 6^\circ\text{C} = 5021\text{ W}$$

With a total of  $2N = 20$  passages, the total heat dissipation is

$$q = 2Nq_1 = 20 \times 5021\text{ W} = 100\text{ kW} \quad <$$

(b) For the air flow,  $\text{Re}_D = u_\infty L / \nu = 10\text{ m/s} \times 0.60\text{m} / 15.89 \times 10^{-6}\text{ m}^2/\text{s} = 378,000$ , and the flow is laminar. From Eq. (7.30),

$$\bar{h} = \frac{k}{L} \text{Nu}_L = 0.664 \frac{k}{L} \text{Re}_L^{1/2} \text{Pr}^{1/3} = \frac{0.664 \times 0.0263\text{ W/m}\cdot\text{K}}{0.60\text{m}} (378,000)^{1/2} (0.707)^{1/3} = 15.9\text{ W/m}^2\cdot\text{K}$$

Heat dissipation to the air from both sides of 10 circuit boards is then

$$q = 2N_{cb} \bar{h} (WL) (T_{s,cb} - T_\infty) = 20 \times 15.9\text{ W/m}^2\cdot\text{K} \times 0.21\text{m}^2 \times 40^\circ\text{C} = 2,670\text{ W} \quad <$$

**COMMENTS:** The cooling capacity of the cold plates far exceeds that of the air flow. However, the challenge would be one of efficiently transferring such a large amount of energy to the cold plates without incurring excessive temperatures on the circuit boards.

### PROBLEM 8.57

**KNOWN:** Flow rate and temperature of Refrigerant-134a passing through a Teflon tube of prescribed inner and outer diameter. Velocity and temperature of air in cross flow over tube.

**FIND:** Heat transfer per unit tube length.

**SCHEMATIC:**

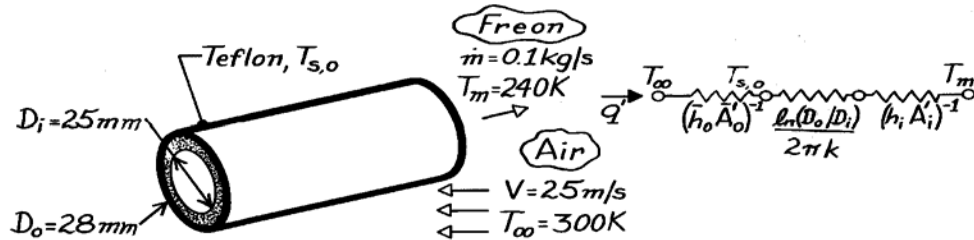

**ASSUMPTIONS:** (1) Steady-state conditions, (2) One-dimensional radial conduction, (3) Constant properties, (4) Fully developed flow.

**PROPERTIES:** Table A-4, Air ( $T = 300$  K, 1 atm):  $\nu = 15.89 \times 10^{-6} \text{ m}^2/\text{s}$ ,  $k = 0.0263 \text{ W/m}\cdot\text{K}$ ,  $\text{Pr} = 0.707$ ; Table A-5, R-134a ( $T = 240$  K):  $\mu = 4.202 \times 10^{-4} \text{ N}\cdot\text{s/m}^2$ ,  $k = 0.1073 \text{ W/m}\cdot\text{K}$ ,  $\text{Pr} = 5.0$ ; Table A-3, Teflon ( $T \approx 300$  K):  $k = 0.35 \text{ W/m}\cdot\text{K}$ .

**ANALYSIS:** Considering the thermal circuit shown above, the heat rate is

$$q' = \frac{T_\infty - T_m}{\left(1/\bar{h}_o \pi D_o\right) + \left[\ln(D_o/D_i)/2\pi k\right] + \left(1/h_i \pi D_i\right)}$$

$$\text{Re}_{D,i} = \frac{4 \dot{m}}{\pi D_i \mu} = \frac{0.4 \text{ kg/s}}{\pi (0.025 \text{ m}) 4.202 \times 10^{-4} \text{ N}\cdot\text{s/m}^2} = 12,120$$

and the flow is turbulent. Hence, from the Dittus-Boelter correlation

$$h_i = \frac{k}{D_i} 0.023 \text{Re}_{D,i}^{4/5} \text{Pr}^{0.4} = \frac{0.1073 \text{ W/m}\cdot\text{K}}{0.025 \text{ m}} 0.023 (12,120)^{4/5} (5)^{0.4} = 347 \text{ W/m}^2 \cdot \text{K}$$

$$\text{With } \text{Re}_{D,o} = \frac{VD_o}{\nu} = \frac{(25 \text{ m/s}) 0.028 \text{ m}}{15.89 \times 10^{-6} \text{ m}^2/\text{s}} = 4.405 \times 10^4$$

it follows from Eq. 7.53 and Table 7.4 that

$$\bar{h}_o = \frac{k}{D} 0.26 \text{Re}_{D,o}^{0.6} \text{Pr}^{0.37} = \frac{0.0263 \text{ W/m}\cdot\text{K}}{0.028 \text{ m}} 0.26 \left(4.405 \times 10^4\right)^{0.6} (0.707)^{0.37} = 131 \text{ W/m}^2 \cdot \text{K}$$

Hence

$$q' = \frac{T_\infty - T_m}{\left(131 \text{ W/m}^2 \cdot \text{K} \pi 0.028 \text{ m}\right)^{-1} + \ln(28/25)/2\pi (0.350 \text{ W/m}\cdot\text{K}) + \left(347 \text{ W/m}^2 \cdot \text{K} \pi 0.025 \text{ m}\right)^{-1}}$$

$$q' = \frac{(300 - 240) \text{ K}}{(0.087 + 0.052 + 0.037) \text{ K}\cdot\text{m/W}} = 343 \text{ W/m} \quad \leftarrow$$

**COMMENTS:** The three thermal resistances are comparable. Note that  $T_{s,o} = T_\infty - q'/h_o \pi D_o = 300 \text{ K} - 343 \text{ W/m}/131 \text{ W/m}^2 \cdot \text{K} \pi 0.028 \text{ m} = 270 \text{ K}$ .

### PROBLEM 8.58

**KNOWN:** Oil flowing slowly through a long, thin-walled pipe suspended in a room.

**FIND:** Heat loss per unit length of the pipe,  $q'_{conv}$ .

**SCHEMATIC:**

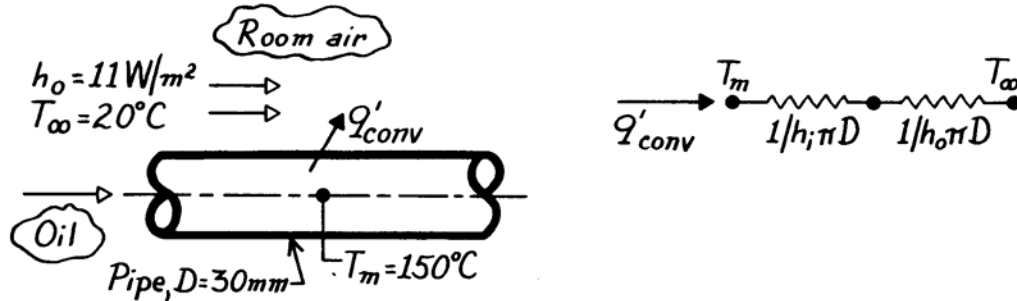

**ASSUMPTIONS:** (1) Steady-state conditions, (2) Tube wall thermal resistance negligible, (3) Fully developed flow, (4) Radiation exchange between pipe and room negligible.

**PROPERTIES:** Table A-5, Unused engine oil ( $T_m = 150^\circ\text{C} = 423\text{K}$ ):  $k = 0.133 \text{ W/m}\cdot\text{K}$ .

**ANALYSIS:** The rate equation, for a unit length of the pipe, can be written as

$$q'_{conv} = \frac{(T_m - T_\infty)}{R'_t}$$

where the thermal resistance is comprised of two elements,

$$R'_t = \frac{1}{h_i \pi D} + \frac{1}{h_o \pi D} = \frac{1}{\pi D} \left( \frac{1}{h_i} + \frac{1}{h_o} \right).$$

The convection coefficient for internal flow,  $h_i$ , must be estimated from an appropriate correlation. From practical considerations, we recognize that the oil flow rate cannot be large enough to achieve turbulent flow conditions. Hence, the flow is *laminar*, and if the pipe is very long, the flow will be *fully developed*. The appropriate correlation is

$$\text{Nu}_D = \frac{h_i D}{k} = 3.66$$

$$h_i = \text{Nu}_D k/D = 3.66 \times 0.133 \frac{\text{W}}{\text{m}\cdot\text{K}} / 0.030 \text{ m} = 16.2 \text{ W/m}^2 \cdot \text{K}.$$

The heat rate per unit length of the pipe is

$$q'_{conv} = \frac{(150 - 20)^\circ\text{C}}{\frac{1}{\pi(0.030\text{m})} \left( \frac{1}{16.2} + \frac{1}{11} \right) \frac{\text{m}^2 \cdot \text{K}}{\text{W}}} = 80.3 \text{ W/m.} \quad <$$

**COMMENTS:** This problem requires making a judgment that the oil flow will be laminar rather than turbulent. Why is this a reasonable assumption? Recognize that the correlation applies to a constant surface temperature condition.

## PROBLEM 8.59

**KNOWN:** Thin-walled, tall stack discharging exhaust gases from an oven into the environment.

**FIND:** (a) Outlet gas and stack surface temperatures,  $T_{m,o}$  and  $T_{s,o}$ , and (b) Effect of wind temperature and velocity on  $T_{m,o}$ .

**SCHEMATIC:**

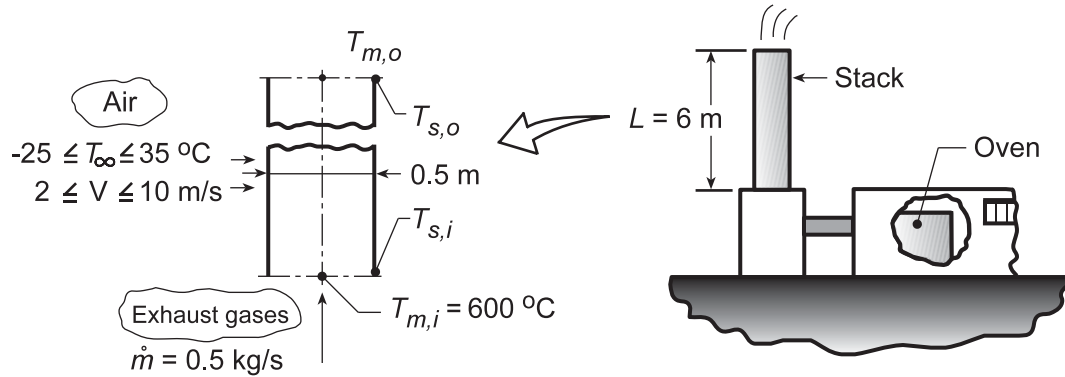

**ASSUMPTIONS:** (1) Steady-state conditions, (2) Wall thermal resistance negligible, (3) Exhaust gas properties approximated as those of atmospheric air, (4) Radiative exchange with surroundings negligible, (5) Ideal gas with negligible viscous dissipation and pressure variation, (6) Fully developed flow, (7) Constant properties.

**PROPERTIES:** *Table A.4*, air (assume  $T_{m,o} = 773$  K,  $\bar{T}_m = 823$  K, 1 atm):  $c_p = 1104$  J/kg·K,  $\mu = 376.4 \times 10^{-7}$  N·s/m<sup>2</sup>,  $k = 0.0584$  W/m·K,  $Pr = 0.712$ ; *Table A.4*, air (assume  $T_s = 523$  K,  $T_\infty = 4^\circ\text{C} = 277$  K,  $T_f = 400$  K, 1 atm):  $\nu = 26.41 \times 10^{-6}$  m<sup>2</sup>/s,  $k = 0.0338$  W/m·K,  $Pr = 0.690$ .

**ANALYSIS:** (a) From Eq. 8.45a,

$$T_{m,o} = T_\infty - (T_\infty - T_{m,i}) \exp\left[-\frac{PL}{\dot{m}c_p} \bar{U}\right] \quad U = 1 / \left( \frac{1}{h_i} + \frac{1}{h_o} \right) \quad (1,2)$$

where  $h_i$  and  $h_o$  are average coefficients for internal and external flow, respectively.

*Internal flow:* With a Reynolds number of

$$Re_{D_i} = \frac{4\dot{m}}{\pi D \mu} = \frac{4 \times 0.5 \text{ kg/s}}{\pi \times 0.5 \text{ m} \times 376.4 \times 10^{-7} \text{ N}\cdot\text{s}/\text{m}^2} = 33,827 \quad (3)$$

the flow is turbulent. Considering the flow to be fully developed throughout the stack ( $L/D = 12$ ) and with  $T_s < T_m$ , the Dittus-Boelter correlation has the form

$$Nu_D = \frac{h_i D}{k} = 0.023 Re_{D_i}^{4/5} Pr^{0.3} \quad (4)$$

$$h_i = \frac{58.4 \times 10^{-3} \text{ W}/\text{m}\cdot\text{K}}{0.5 \text{ m}} \times 0.023 (33,827)^{4/5} (0.712)^{0.3} = 10.2 \text{ W}/\text{m}^2 \cdot \text{K}.$$

*External flow:* Working with the Churchill/Bernstein correlation, the Reynolds and Nusselt numbers are

$$Re_{D_o} = \frac{VD}{\nu} = \frac{5 \text{ m/s} \times 0.5 \text{ m}}{26.41 \times 10^{-6} \text{ m}^2/\text{s}} = 94,660 \quad (5)$$

Continued...



**PROBLEM 8.59 (Cont.)**

$$\overline{Nu}_D = 0.3 + \frac{0.62 Re_D^{1/2} Pr^{1/3}}{\left[1 + (0.4/Pr)^{2/3}\right]^{1/4}} \left[1 + \left(\frac{Re_D}{282,000}\right)^{5/8}\right]^{4/5} = 205$$

Hence,

$$h_o = (0.0338 \text{ W/m} \cdot \text{K} / 0.5 \text{ m}) \times 205 = 13.9 \text{ W/m}^2 \cdot \text{K} \quad (6)$$

The outlet gas temperature is then

$$T_{m,o} = 4^\circ\text{C} - (4 - 600)^\circ\text{C} \exp\left[-\frac{\pi \times 0.5 \text{ m} \times 6 \text{ m}}{0.5 \text{ kg/s} \times 1104 \text{ J/kg} \cdot \text{K}} \left(\frac{1}{1/10.2 + 1/13.9} \text{ W/m}^2 \cdot \text{K}\right)\right] = 543^\circ\text{C} \quad <$$

The outlet stack surface temperature can be determined from a local surface energy balance of the form,  $h_i(T_{m,o} - T_{s,o}) = h_o(T_{s,o} - T_\infty)$ , which yields

$$T_{s,o} = \frac{h_i T_{m,o} + h_o T_\infty}{h_i + h_o} = \frac{(10.2 \times 543 + 13.9 \times 4) \text{ W/m}^2}{(10.2 + 13.9) \text{ W/m}^2 \cdot \text{K}} = 232^\circ\text{C} \quad <$$

(b) Using the Correlations and Properties Toolpads of IHT, with a surface temperature of  $T_s = 523 \text{ K}$  assumed solely for the purpose of evaluating properties associated with airflow over the cylinder, the following results were generated.

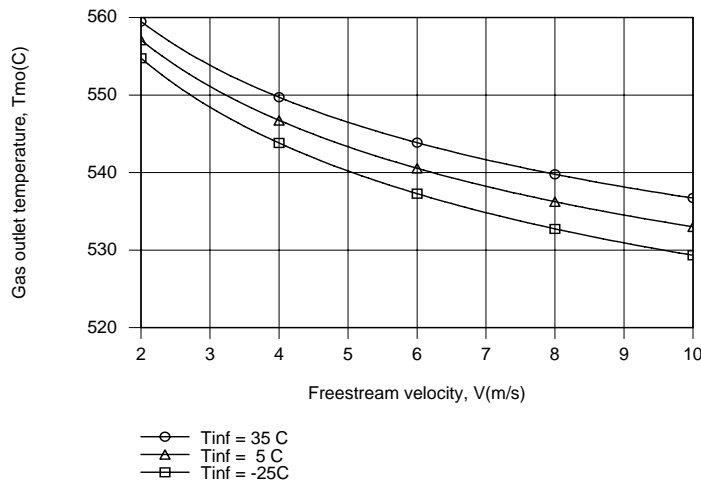

Due to the elevated temperatures of the gas, the variation in ambient temperature has only a small effect on the gas exit temperature. However, the effect of the freestream velocity is more pronounced.

Discharge temperatures of approximately 530 and 560°C would be representative of cold/windy and warm/still atmospheric conditions, respectively.

**COMMENTS:** If there are constituents in the discharge gas flow that condense or precipitate out at temperatures below  $T_{s,o}$ , this operating condition should be avoided.

### PROBLEM 8.60

**KNOWN:** Hot fluid passing through a thin-walled tube with coolant in cross flow over the tube. Fluid flow rate and inlet and outlet temperatures.

**FIND:** Outlet temperature,  $T_{m,o}$ , if the flow rate is increased by a factor of 2 with all other conditions the same.

**SCHEMATIC:**

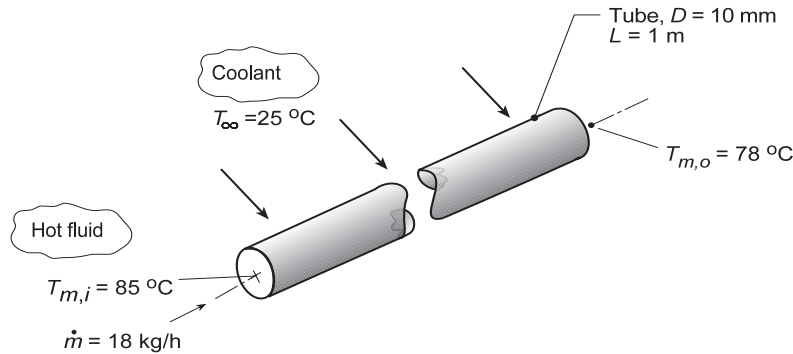

**ASSUMPTIONS:** (1) Steady-state conditions, (2) Hot fluid is incompressible with negligible viscous dissipation, (3) Constant properties, (4) Fully developed flow and thermal conditions, (5) Convection coefficients,  $\bar{h}_o$  and  $\bar{h}_i$ , independent of temperature, and (6) Negligible wall thermal resistance.

**PROPERTIES:** Hot fluid (Given):  $\rho = 1079 \text{ kg/m}^3$ ,  $c_p = 2637 \text{ J/kg}\cdot\text{K}$ ,  $\mu = 0.0034 \text{ N}\cdot\text{s/m}^2$ ,  $k = 0.261 \text{ W/m}\cdot\text{K}$ .

**ANALYSIS:** For conditions prescribed in the Schematic, Eq. 8.45a can be used to evaluate the overall convection coefficient with  $P = \pi D$ ,

$$\frac{T_{\infty} - T_{m,o}}{T_{\infty} - T_{m,i}} = \exp\left(-\frac{PL}{\dot{m}_o c_p} \bar{U}\right) \quad (1)$$

$$\frac{(25 - 78)^\circ\text{C}}{(25 - 85)^\circ\text{C}} = \exp\left(-\frac{\pi \times 0.010 \text{ m} \times 1 \text{ m}}{(18/3600) \text{ kg/s} \times 2637 \text{ J/kg}\cdot\text{K}} \bar{U}\right)$$

$$U = 52.1 \text{ W/m}^2 \cdot \text{K}$$

The overall coefficient can be expressed in terms of the inside and outside coefficients,

$$U = (1/\bar{h}_i + 1/\bar{h}_o)^{-1} \quad (2)$$

Characterize the internal flow with the Reynolds number, Eq. 8.6,

$$\text{Re}_D = \frac{4\dot{m}_o}{\pi D \mu} = \frac{4 \times (18/3600) \text{ kg/s}}{\pi \times 0.010 \text{ m} \times 0.0034 \text{ N}\cdot\text{s/m}^2} = 187$$

and since the flow is laminar, and assumed to be fully developed,  $\bar{h}_i$  will not change when the flow rate is doubled. That is,  $U = 52.1 \text{ W/m}^2\cdot\text{K}$  when  $\dot{m} = 2\dot{m}_o$ . Using Eq. (1) again, but with  $T_{m,o}$  unknown,

$$\frac{(25 - T_{m,o})^\circ\text{C}}{(25 - 85)^\circ\text{C}} = \exp\left(-\frac{\pi \times 0.010 \text{ m} \times 1 \text{ m}}{2(18/3600) \text{ kg/s} \times 2637 \text{ J/kg}\cdot\text{K}} \times 52.1 \text{ W/m}^2 \cdot \text{K}\right)$$

$$T_{m,o} = 81.4^\circ\text{C} \quad <$$

**COMMENTS:** Examine the assumptions and explain why they were necessary in order to affect the solution.

## PROBLEM 8.61

**KNOWN:** Thin walled tube of prescribed diameter and length. Water inlet temperature and flow rate.

**FIND:** (a) Outlet temperature of the water when the tube surface is maintained at a uniform temperature  $T_s = 27^\circ\text{C}$  assuming  $\bar{T}_m = 300\text{ K}$  for evaluating water properties, (b) Outlet temperature of the water when the tube is heated by cross flow of air with  $V = 10\text{ m/s}$  and  $T_\infty = 100^\circ\text{C}$  assuming  $\bar{T}_f = 350\text{ K}$  for evaluating air properties, and (c) Outlet temperature of the water for the conditions of part (b) using properly evaluated properties.

**SCHEMATIC:**

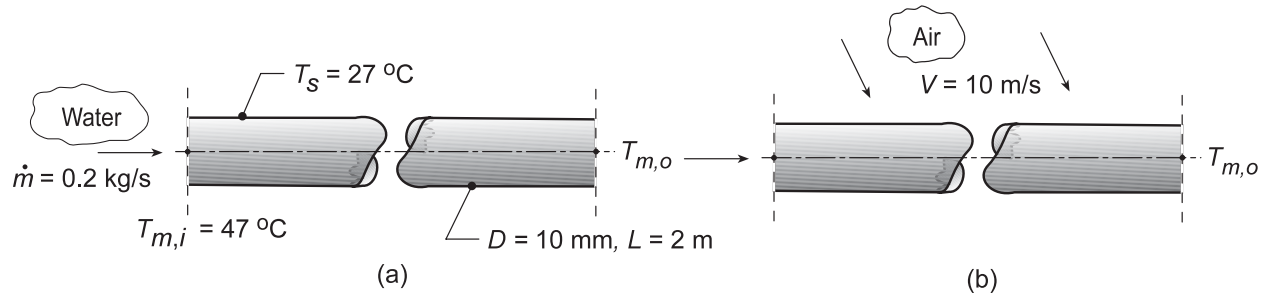

**ASSUMPTIONS:** (1) Steady-state conditions, (2) Incompressible liquid with negligible viscous dissipation and negligible axial conduction, (3) Fully developed flow and thermal conditions for internal flow, and (4) Negligible tube wall thermal resistance.

**PROPERTIES:** Table A.6, Water ( $\bar{T}_m = 300\text{ K}$ ):  $\rho = 997\text{ kg/m}^3$ ,  $c_p = 4179\text{ J/kg}\cdot\text{K}$ ,  $\mu = 855 \times 10^{-6}\text{ N}\cdot\text{s/m}^2$ ,  $k = 0.613\text{ W/m}\cdot\text{K}$ ,  $\text{Pr} = 5.83$ ; Table A.4, Air ( $\bar{T}_f = 350\text{ K}$ , 1 atm):  $\nu = 20.92 \times 10^{-6}\text{ m}^2/\text{s}$ ,  $k = 0.030\text{ W/m}\cdot\text{K}$ ,  $\text{Pr} = 0.700$ .

**ANALYSIS:** (a) For the constant wall temperature cooling process,  $T_s = 27^\circ\text{C}$ , the water outlet temperature can be determined from Eq. 8.41b, with  $P = \pi D$ ,

$$\frac{T_s - T_{m,o}}{T_s - T_{m,i}} = \exp\left(-\frac{PL}{\dot{m}c_p} \bar{h}_i\right) \quad (1)$$

To estimate the convection coefficient, characterize the flow evaluating properties at  $\bar{T}_m = 300\text{ K}$

$$\text{Re}_D = \frac{4\dot{m}}{\pi D \mu} = \frac{4 \times 0.2\text{ kg/s}}{\pi \times 0.010\text{ m} \times 855 \times 10^{-6}\text{ N}\cdot\text{s/m}^2} = 29,783$$

Hence, the flow is turbulent and assuming fully developed ( $L/D = 200$ ), and using the Dittus-Boelter correlation, Eq. 8.60, find  $\bar{h}_i$ ,

$$\text{Nu}_D = \frac{\bar{h}_i D}{k} = 0.023 \text{Re}_D^{0.8} \text{Pr}^{0.3} \quad \bar{h}_i = \frac{0.613\text{ W/m}\cdot\text{K}}{0.010\text{ m}} 0.023 (29,783)^{0.8} (5.83)^{0.3} = 9080\text{ W/m}^2\cdot\text{K} \quad (2)$$

Substituting this value for  $\bar{h}_i$  into Eq. (1), find

$$\frac{(27 - T_{m,o})}{(27 - 47)^\circ\text{C}} = \exp\left(-\frac{\pi \times 0.010\text{ m} \times 2\text{ m}}{0.2\text{ kg/s} \times 4179\text{ J/kg}\cdot\text{K}} \times 9080\text{ W/m}^2\cdot\text{K}\right) \quad T_{m,o} = 37.1^\circ\text{C} <$$

(b) For the air heating process,  $T_\infty = 100^\circ\text{C}$ , the water outlet temperature follows from Eq. 8.45a,

$$\frac{T_\infty - T_{m,o}}{T_\infty - T_{m,i}} = \exp\left(-\frac{\pi DL}{\dot{m}c_p} \bar{U}\right) \quad (3)$$

Continued...

**PROBLEM 8.61 (Cont.)**

where the overall coefficient is  $\bar{U} = (1/\bar{h}_i + 1/\bar{h}_o)$  (4)

To estimate  $\bar{h}_o$ , use the Churchill-Bernstein correlation, Eq. 7.54, for cross flow over a cylinder using properties evaluated at  $\bar{T}_f = 350$  K.

$$Re_D = \frac{VD}{\nu} = \frac{10 \text{ m/s} \times 0.010 \text{ m}}{20.92 \times 10^{-6} \text{ m}^2/\text{s}} = 4780 \quad (5)$$

$$\bar{Nu}_D = 0.3 + \frac{0.62 Re_D^{1/2} Pr^{1/3}}{\left[1 + (0.4/Pr)^{2/3}\right]^{1/4}} \left[1 + \left(\frac{Re_D}{282,000}\right)^{5/8}\right]^{4/5} \quad (6)$$

$$\bar{Nu}_D = 0.3 + \frac{0.62(4780)^{1/2} (0.700)^{1/3}}{\left[1 + (0.4/0.700)^{2/3}\right]^{1/4}} \left[1 + \left(\frac{4780}{282,000}\right)^{5/8}\right]^{4/5} = 35.76$$

$$\bar{h}_o = \frac{\bar{Nu}_D k}{D} = \frac{0.030 \text{ W/m} \cdot \text{K}}{0.010 \text{ m}} \times 35.76 = 107 \text{ W/m}^2 \cdot \text{K}$$

The value of  $\bar{h}_i$  can be recalculated for heating conditions:

$$Nu_D = \frac{\bar{h}_i D}{k} = 0.023 Re_D^{0.8} Pr^{0.4} \quad \bar{h}_i = \frac{0.613 \text{ W/m} \cdot \text{K}}{0.010 \text{ m}} 0.023 (29,783)^{0.8} (5.83)^{0.4} = 10,800 \text{ W/m}^2 \cdot \text{K}$$

Next, find  $\bar{U}$  then  $T_{m,o}$ ,

$$\bar{U} = (1/10,800 + 1/107)^{-1} \text{ W/m}^2 \cdot \text{K} = 106 \text{ W/m}^2 \cdot \text{K}$$

$$\frac{100 - T_{m,o}}{(100 - 47)^\circ \text{C}} = \exp\left(-\frac{\pi \times 0.010 \text{ m} \times 2 \text{ m}}{0.2 \text{ kg/s} \times 4179 \text{ J/kg} \cdot \text{K}} \times 106 \text{ W/m}^2 \cdot \text{K}\right) \quad T_{m,o} = 47.4^\circ \text{C} <$$

(c) Using the *IHT Correlation Tools for Internal Flow (Turbulent Flow)* and *External Flow (over a Cylinder)* the analyses of part (b) were performed considering the appropriate temperatures to evaluate the thermophysical properties. For internal and external flow, respectively,

$$\bar{T}_m = (T_{m,i} + T_{m,o})/2 \quad \bar{T}_f = (\bar{T}_s + T_\infty)/2 \quad (7,8)$$

where the average tube wall temperature is evaluated from the thermal circuit,

$$\frac{\bar{T}_m - \bar{T}_s}{1/\bar{h}_i} = \frac{\bar{T}_s - T_\infty}{1/\bar{h}_o} \quad (9)$$

The results of the analyses are summarized in the table along with the results from parts (a) and (b),

Condition	$\bar{T}_m$ (K)	$\bar{h}_i$ (W/m <sup>2</sup> ·K)	$\bar{T}_f$ (K)	$\bar{h}_o$ (W/m <sup>2</sup> ·K)	$\bar{U}$ (W/m <sup>2</sup> ·K)	$T_{m,o}$ (°C)
$T_s = 27^\circ \text{C}$	300	9080	---	---	---	37.1°C
$T_\infty = 100^\circ \text{C}, T_f = 350^\circ \text{C}$	300	10,800	350	107	106	47.4°C
Exact solution	320	13,000	347	107.3	106.3	47.4°C

Continued...

**PROBLEM 8.61 (Cont.)**

Note that since  $\bar{h}_o \ll \bar{h}_i$ ,  $\bar{U}$  is controlled by the value of  $\bar{h}_o$  which was evaluated near 350 K for both parts (b) and (c). Hence, it follows that  $T_{m,o}$  is not very sensitive to  $\bar{h}_i$  which, as seen above, is sensitive to the value of  $\bar{T}_m$ .

## PROBLEM 8.62

**KNOWN:** Diameter of tube through which water of prescribed flow rate and inlet and outlet temperatures flows. Temperature of fluid in cross flow over the tube.

**FIND:** (a) Required tube length for air in cross flow at prescribed velocity, (b) Required tube length for water in cross flow at a prescribed velocity.

**SCHEMATIC:**

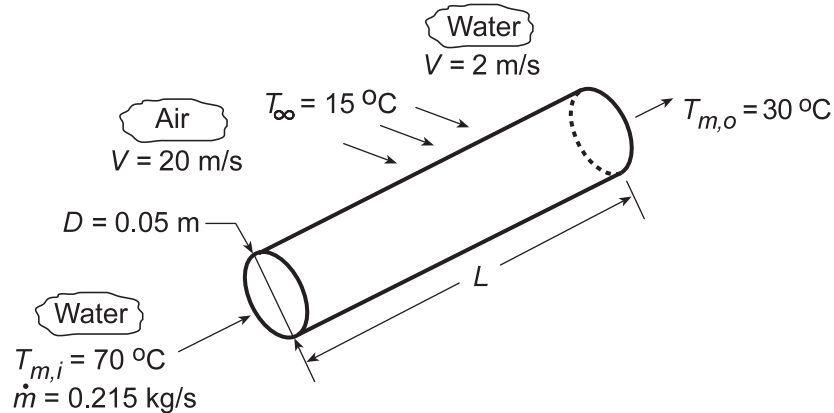

**ASSUMPTIONS:** (1) Steady-state, (2) Constant properties, (3) Negligible tube wall conduction resistance, (4) Water is incompressible liquid with negligible viscous dissipation.

**PROPERTIES:** Table A.6, water ( $\bar{T}_m = 50^\circ\text{C} = 323\text{ K}$ ):  $c_p = 4181\text{ J/kg}\cdot\text{K}$ ,  $\mu = 548 \times 10^{-6}\text{ N}\cdot\text{s/m}^2$ ,  $k = 0.643\text{ W/m}\cdot\text{K}$ ,  $\text{Pr} = 3.56$ . Table A.4, air (assume  $T_f = 300\text{ K}$ ):  $\nu = 15.89 \times 10^{-6}\text{ m}^2/\text{s}$ ,  $k = 0.0263\text{ W/m}\cdot\text{K}$ ,  $\text{Pr} = 0.707$ . Table A.6, water (assume  $T_f = 300\text{ K}$ ):  $\nu = 0.858 \times 10^{-6}\text{ m}^2/\text{s}$ ,  $k = 0.613\text{ W/m}\cdot\text{K}$ ,  $\text{Pr} = 5.83$ .

**ANALYSIS:** The required heat rate may be determined from the overall energy balance,

$$q = \dot{m}c_p(T_{m,i} - T_{m,o}) = 0.215\text{ kg/s}(4181\text{ J/kg}\cdot\text{K})40^\circ\text{C} = 35,960\text{ W}$$

and the required tube length may be determined from the rate equation, Eq. 8.46a,

$$L = \frac{q}{U\pi D\Delta T_{\ell m}}$$

where

$$\Delta T_{\ell m} = \frac{(T_{m,i} - T_\infty) - (T_{m,o} - T_\infty)}{\ln\left(\frac{T_{m,i} - T_\infty}{T_{m,o} - T_\infty}\right)} = 30.8^\circ\text{C} \quad \text{and} \quad 1/U = 1/h_i + 1/h_o.$$

With

$$\text{Re}_{D_i} = 4\dot{m}/\pi D\mu = 0.860\text{ kg/s}/\pi(0.05\text{ m})548 \times 10^{-6}\text{ N}\cdot\text{s/m}^2 = 9991$$

the flow is turbulent and, assuming fully developed flow throughout the tube, the inside convection coefficient is determined from Eq. 8.62

$$\text{Nu}_{D_i} = \frac{(f/8)(\text{Re}_{D_i} - 1000)\text{Pr}}{1 + 12.7(f/8)^{1/2}(\text{Pr}^{2/3} - 1)} = \frac{(0.0315/8)(9991 - 1000)3.56}{1 + 12.7(0.0315/8)^{1/2}(3.56^{2/3} - 1)} = 61.1$$

where  $f = (0.79 \ln \text{Re}_{D_i} + 1.64)^{-2} = 0.0315$

$$h_i = \text{Nu}_{D_i} k/D = 61.1(0.643\text{ W/m}\cdot\text{K})/0.05\text{ m} = 786\text{ W/m}^2\cdot\text{K}$$

Continued...

### PROBLEM 8.62 (Cont.)

(a) For air in cross flow at 20 m/s,  $Re_{D_o} = VD/v = 20 \text{ m/s}(0.05 \text{ m})/15.89 \times 10^{-6} \text{ m}^2/\text{s} = 62,933$ . From the Churchill/Bernstein correlation, it follows that

$$Nu_{D_o} = 0.3 + \frac{0.62 Re_{D_o}^{1/2} Pr^{1/3}}{\left[1 + (0.4/Pr)^{2/3}\right]^{1/4}} \left[1 + \left(\frac{Re_{D_o}}{282,000}\right)^{5/8}\right]^{4/5} = 158.7$$

$$h_o = Nu_{D_o} k/D = 158.7(0.0263 \text{ W/m} \cdot \text{K})/0.05 \text{ m} = 83.5 \text{ W/m}^2 \cdot \text{K}$$

Hence,  $U = (1/h_i + 1/h_o)^{-1} = 75.5 \text{ W/m}^2 \cdot \text{K}$  and

$$L = \frac{35,960 \text{ W}}{\left(75.5 \text{ W/m}^2 \cdot \text{K}\right) \pi (0.05 \text{ m}) 30.8^\circ \text{C}} = 98.5 \text{ m} \quad <$$

(b) For water in cross flow at 2 m/s,  $Re_{D_o} = 2 \text{ m/s}(0.05 \text{ m})/0.858 \times 10^{-6} \text{ m}^2/\text{s} = 116,550$ , and the correlation yields  $Nu_{D_o} = 527.3$ . Hence,

$$h_o = Nu_{D_o} k/D = 527.3(0.613 \text{ W/m} \cdot \text{K})/0.05 \text{ m} = 6,465 \text{ W/m}^2 \cdot \text{K}$$

$$U = (1/h_i + 1/h_o)^{-1} = 701 \text{ W/m}^2 \cdot \text{K}$$

Hence,

$$L = \frac{35,960 \text{ W}}{\left(701 \text{ W/m}^2 \cdot \text{K}\right) \pi (0.05 \text{ m}) 30.8^\circ \text{C}} = 10.6 \text{ m} \quad <$$

**COMMENTS:** The foregoing results clearly indicate the superiority of water (relative to air) as a heat transfer fluid. Note the dominant contribution made by the smaller convection coefficient to the value of  $U$  in each of the two cases.

## PROBLEM 8.63

**KNOWN:** Length, diameter, insulation characteristics and burial depth of a pipe. Ground surface temperature. Inlet temperature, flow rate and properties of oil flowing through pipe.

**FIND:** (a) An expression for the oil outlet temperature, (b) Oil outlet temperature and pipe heat transfer rate for prescribed conditions, and (c) Design information for trade off between burial depth of pipe ( $z$ ) and pipe insulation thickness ( $t$ ) on the heat loss.

**SCHEMATIC:**

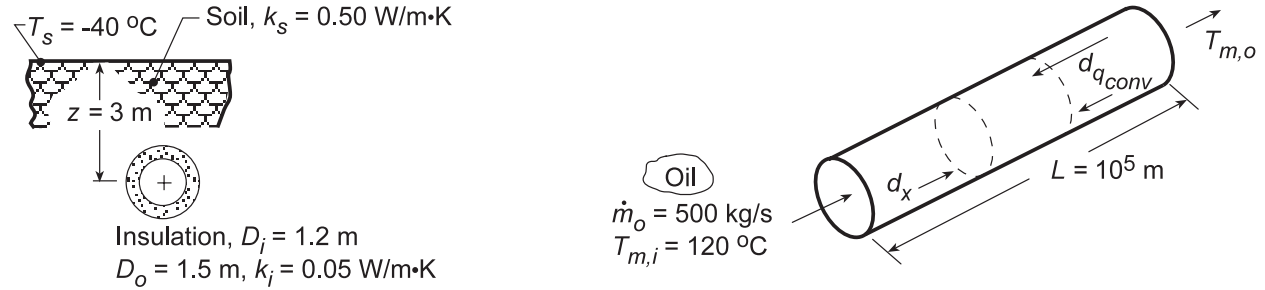

**ASSUMPTIONS:** (1) Steady-state conditions, (2) Constant properties, (3) Two-dimensional conduction in soil, (4) Negligible pipe wall thermal resistance, (5) Total resistance to heat loss is independent of  $x$ , (6) Oil is incompressible liquid with negligible viscous dissipation.

**PROPERTIES:** Oil (given):  $\rho_o = 900 \text{ kg/m}^3$ ,  $c_{p,o} = 2000 \text{ J/kg}\cdot\text{K}$ ,  $\nu_o = 8.5 \times 10^{-4} \text{ m}^2/\text{s}$ ,  $k_o = 0.140 \text{ W/m}\cdot\text{K}$ ,  $\text{Pr}_o = 10^4$ ; Soil (given):  $k_s = 0.50 \text{ W/m}\cdot\text{K}$ ; Insulation (given):  $k_i = 0.05 \text{ W/m}\cdot\text{K}$ .

**ANALYSIS:** (a) From Eq. 8.36 for a differential control volume in the oil and the rate equation

$$dq_{\text{conv}} = \dot{m}_o c_{p,o} dT_m = dq = (T_s - T_m) / R_{\text{tot}} \quad (1)$$

where the total resistance is expressed as

$$R_{\text{tot}} = R_{\text{conv}} + R_{\text{cond},i} + R_{\text{cond},s} = (\bar{h}\pi D dx)^{-1} + \frac{\ln(D_o/D_i)}{2\pi k_i dx} + \frac{1}{k_s S}$$

$$R_{\text{tot}} = \left( \frac{1}{\bar{h}\pi D_i} + \frac{\ln(D_o/D_i)}{2\pi k_i} + \frac{\cosh^{-1}(2z/D_o)}{2\pi k_s} \right) / dx = R'_{\text{tot}} / dx \quad (2)$$

where, from Table 4.1,

$$S = 2\pi dx / \cosh^{-1}(2z/D_o) \quad (3)$$

It follows that

$$\frac{(T_s - T_m) dx}{R'_{\text{tot}}} = \dot{m}_o c_{p,o} dT_m \quad \frac{dT_m}{T_s - T_m} = \frac{dx}{\dot{m}_o c_{p,o} R'_{\text{tot}}}$$

Integrating between inlet and outlet conditions

$$\int_{T_{m,i}}^{T_{m,o}} \frac{dT_m}{T_m - T_s} = - \int_0^L \frac{dx}{\dot{m}_o c_{p,o} R'_{\text{tot}}}$$

Assuming  $R'_{\text{tot}}$  to be independent of  $x$  and integrating,

$$\frac{T_{m,o} - T_s}{T_{m,i} - T_s} = \exp\left( - \frac{L}{\dot{m}_o c_{p,o} R'_{\text{tot}}} \right). \quad (3) <$$

Continued...



### PROBLEM 8.63 (Cont.)

(b) To calculate  $T_{m,o}$  for the prescribed conditions, begin by evaluating  $\bar{h}$ , where

$$Re_D = \frac{4\dot{m}_o}{\pi D_i \rho_o \nu_o} = \frac{4 \times 500 \text{ kg/s}}{\pi (1.2 \text{ m}) 900 \text{ kg/m}^3 \times 8.5 \times 10^{-4} \text{ m}^2/\text{s}} = 694 \quad (4)$$

Hence, the flow is laminar, and with  $Pr_o > 5$ , the Hausen correlation is appropriate,

$$\overline{Nu}_D = 3.66 + \frac{0.0668 Gz_D}{1 + 0.04 Gz_D^{2/3}} \quad (5)$$

$$Gz_D = (D_i/L) Re_D Pr = \left( \frac{1.2}{10^5} \right) (694) 10^4 = 83.3 \quad \overline{Nu}_D = 6.82$$

$$\bar{h} = \frac{k}{D_i} 6.82 = \frac{0.14 \text{ W/m} \cdot \text{K}}{1.2 \text{ m}} 6.82 = 0.80 \text{ W/m}^2 \cdot \text{K}$$

From Eq. (2), the overall thermal resistance is

$$R'_{tot} = \frac{1}{0.8 \text{ W/m}^2 \cdot \text{K} \pi (1.2 \text{ m})} + \frac{\ln(1.5/1.2)}{2\pi (0.05 \text{ W/m} \cdot \text{K})} + \frac{\cosh^{-1}(4)}{2\pi (0.5 \text{ W/m} \cdot \text{K})}$$

$$R'_{tot} = (0.33 + 0.71 + 0.66) \text{ K} \cdot \text{m/W} = 1.70 \text{ K} \cdot \text{m/W}$$

and the oil outlet temperature can be calculated as

$$\frac{T_{m,o} - T_s}{T_{m,i} - T_s} = \exp\left(-\frac{10^5 \text{ m}}{500 \text{ kg/s} \times 2000 \text{ J/kg} \cdot \text{K} \times 1.7 \text{ K} \cdot \text{m/W}}\right) = 0.943$$

$$T_{m,o} = 110.9^\circ\text{C} \quad <$$

The total rate of heat transfer *from* the pipeline is then

$$q = \dot{m}_o c_{p,o} (T_{m,i} - T_{m,o}) \quad (6)$$

$$q = 500 \text{ kg/s} \times 2000 \text{ J/kg} \cdot \text{K} (120 - 110.9)^\circ\text{C} = 9.1 \times 10^6 \text{ W}. \quad <$$

(c) Using the *IHT Workspace* with the foregoing equations, an analysis was performed to determine the heat loss,  $q$ , as a function of burial depth for the range,  $1 \leq z \leq 6 \text{ m}$ , for thicknesses of insulation which are -25%, +25%, +50% and 100% that of the base case,  $t = r_o - r_i = 150 \text{ mm}$ .

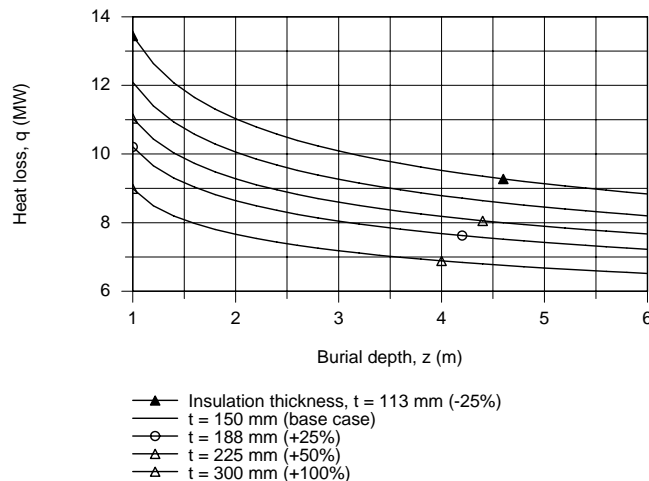

Continued...

### PROBLEM 8.63 (Cont.)

From this information, the operations manager can compare the costs associated with burial depth and insulation thickness with respect to acceptable heat loss.

**COMMENTS:** (1) Since the thermal entry region is very long,  $x_{fd,t} \approx 0.05DR_{eD}Pr = 4.16 \times 10^5$  m,  $h_x$  will be changing with  $x$  throughout the pipe. A more accurate solution would therefore be one in which Eq. (1) is integrated numerically, in a step-by-step fashion. For example, the integration could involve a step width of  $\Delta x = 10^3$  m, with  $h$  and  $R'_t$  evaluated at each step.

(2) The three contributions to the total thermal resistance are comparable.

(3) In IHT 3.0, the inverse hyperbolic cosine function is “`invcosh`,” so the shape factor can be found as:

```
// Shape factor:  
S = 2 * pi / invcosh(arg)  
arg = 2*z/Do  
z = 3  
Do = 1.5
```

Note that the argument of a function must be calculated separately in IHT. That is, we cannot use `invcosh(2*z/Do)`.

## PROBLEM 8.64

**KNOWN:** Length, diameter, insulation characteristics and burial depth of pipe. Ground surface temperature. Inlet temperature, minimum allowable exit temperature, flow rate and properties of oil flow through pipe.

**FIND:** Effect of soil thermal conductivity and flowrate on heat rate and outlet temperature.

**SCHEMATIC:**

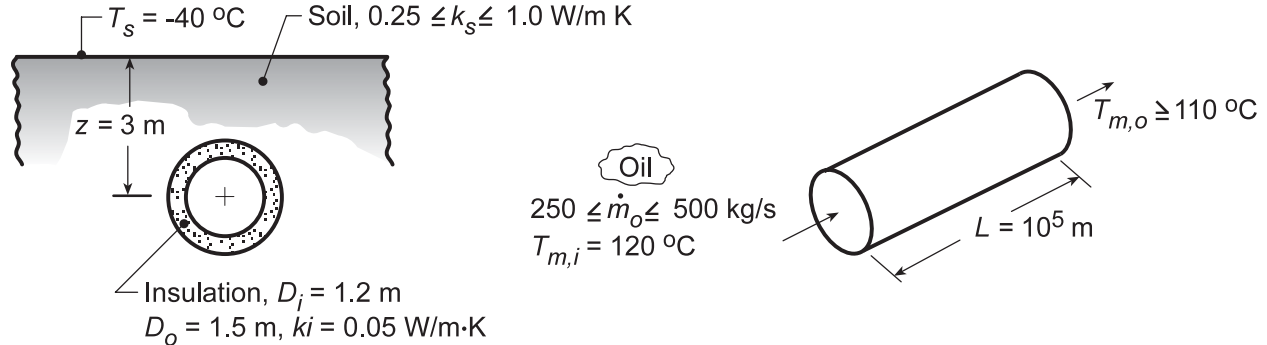

**ASSUMPTIONS:** (1) Steady-state conditions, (2) Constant properties, (3) Two-dimensional conduction in soil, (4) Negligible pipe wall thermal resistance, (5) Total resistance to heat loss is independent of  $x$ , (6) Oil is incompressible liquid with negligible viscous dissipation.

**PROPERTIES:** Oil (given):  $\rho_o = 900 \text{ kg/m}^3$ ,  $c_{p,o} = 2000 \text{ J/kg}\cdot\text{K}$ ,  $\nu_o = 8.5 \times 10^{-4} \text{ m}^2/\text{s}$ ,  $k_o = 0.140 \text{ W/m}\cdot\text{K}$ ,  $Pr_o = 10^4$ .

**ANALYSIS:** From the analysis of Problem 8.63, the outlet temperature may be computed from the expression

$$\frac{T_{m,o} - T_s}{T_{m,i} - T_s} = \exp\left(-\frac{L}{\dot{m}c_{p,o}R'_{\text{tot}}}\right)$$

where

$$R'_{\text{tot}} = \frac{1}{\bar{h}\pi D_i} + \frac{\ln(D_o/D_i)}{2\pi k_i} + \frac{\cosh^{-1}(2z/D_o)}{2\pi k_s}$$

and  $\bar{h}$  is determined from Eq. 8.57. The heat rate may then be obtained from the overall energy balance

$$q = \dot{m}c_p(T_{m,i} - T_{m,o})$$

Using the *Correlations* Toolpad of IHT to perform the parametric calculations, the following results were obtained.

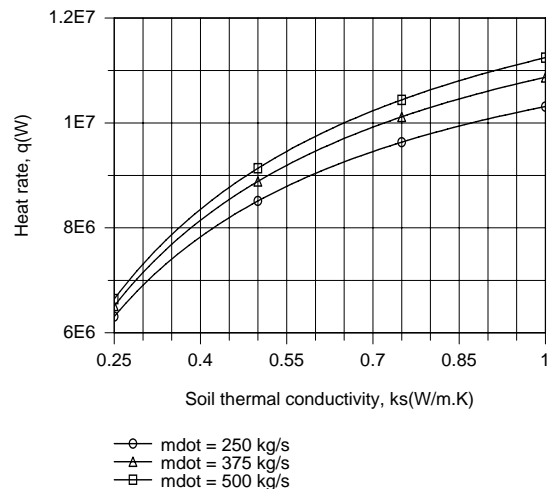
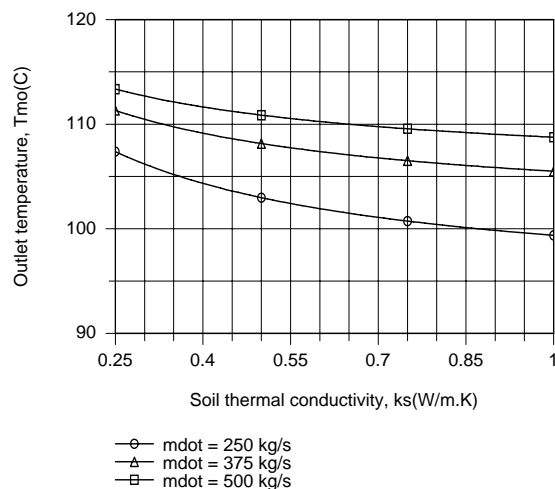

Continued...

### PROBLEM 8.64 (Cont.)

Due to a reduction in the thermal conduction resistance of the soil with increasing  $k_s$ , there is a corresponding increase in the heat rate  $q$  from the pipe and a reduction in the oil outlet temperature. The heat rate also increases with increasing  $\dot{m}$  (due to an increase in  $\bar{h}$  and hence a decrease in the convection resistance), but the increase lags that of the flow rate, causing the outlet temperature to increase with increasing  $\dot{m}$ . Conditions for which  $T_{m,o} \geq 110^\circ\text{C}$  cannot be achieved for  $\dot{m} = 250 \text{ kg/s}$ , but can be achieved for  $k_s \leq 0.33 \text{ W/m}\cdot\text{K}$  and  $k_s \leq 0.65 \text{ W/m}\cdot\text{K}$  for  $\dot{m} = 375 \text{ kg/s}$  and  $500 \text{ kg/s}$ , respectively. The worst case condition corresponds to the smallest value of  $\dot{m}$  and the largest value of  $k_s$ .

Measures to maintain  $T_{m,o} \geq 110^\circ\text{C}$  could include increasing the burial depth, increasing the insulation thickness, and/or using an insulation of lower thermal conductivity.

**COMMENTS:** The thermophysical properties of oil depend strongly on temperature, and a more accurate solution would account for the effect of variations in  $\bar{T}_m$  on the properties.

### PROBLEM 8.65

**KNOWN:** Water flow rate and inlet temperature for a thin-walled tube of prescribed length and diameter.

**FIND:** Water outlet temperature for each of the following conditions: (a) Tube surface maintained at 27°C, (b) Insulation applied and outer surface maintained at 27°C, (c) Insulation applied and outer surface exposed to ambient air at 27°C.

**SCHEMATIC:**

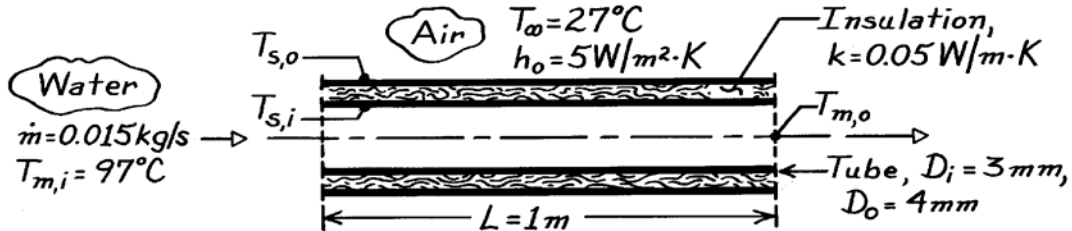

**ASSUMPTIONS:** (1) Steady-state conditions, (2) Fully developed flow throughout the tube, (3) Negligible tube wall conduction resistance, (4) Negligible contact resistance between tube wall and insulation, (5) Uniform outside convection coefficient.

**PROPERTIES:** Assume water cools to  $T_{m,o} = 27^\circ\text{C}$  with no insulation but that cooling is negligible ( $T_{m,o} = 97^\circ\text{C}$ ) with insulation. *Table A-4*, Water ( $\bar{T}_m = 335\text{K}$ ):  $c_p = 4186\text{ J/kg}\cdot\text{K}$ ,  $\mu = 453 \times 10^{-6}\text{ N}\cdot\text{s/m}^2$ ,  $k = 0.656\text{ W/m}\cdot\text{K}$ ,  $\text{Pr} = 2.88$ ; *Table A-4*, Water ( $T_{m,i} = 370\text{K}$ ):  $c_p = 4214\text{ J/kg}\cdot\text{K}$ ,  $\mu = 289 \times 10^{-6}\text{ N}\cdot\text{s/m}^2$ ,  $k = 0.679\text{ W/m}\cdot\text{K}$ ,  $\text{Pr} = 1.80$ .

**ANALYSIS:** For each of the three cases, heat is transferred from the warm water to a surface (or the air) which is at a fixed temperature ( $27^\circ\text{C}$ ). Accordingly, an expression of the form given by Eq. 8.41b may be used to determine the outlet temperature of the water, so long as the appropriate heat transfer coefficient is used. In particular, each of the cases can be described by Eq. 8.45a.

$$\frac{\Delta T_o}{\Delta T_i} = \exp\left(-\frac{\bar{U}A_s}{\dot{m}c_p}\right)$$

Referring to the thermal circuit associated with heat transfer from the water,

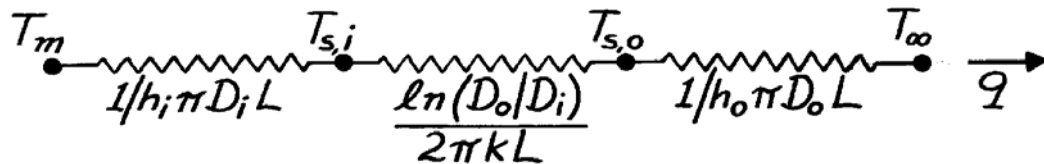

and the  $UA$  product may be evaluated as

$$UA = (\sum R_t)^{-1}.$$

(a) For the first case:  $T_{s,i} = 27^\circ\text{C}$     $\Delta T_i = T_{m,i} - T_{s,i} = 70^\circ\text{C}$     $UA = h_i \pi D_i L$ .

$$\text{Re}_D = \frac{4\dot{m}}{\pi D_i \mu} = \frac{4 \times 0.015\text{ kg/s}}{\pi (0.003\text{ m}) 453 \times 10^{-6}\text{ N}\cdot\text{s/m}^2} = 14,053.$$

Continued ...

**PROBLEM 8.65 (Cont.)**

From Eq. 8.60,

$$h_i = \frac{k}{D_i} 0.023 \text{Re}_D^{4/5} \text{Pr}^{0.30} = \frac{0.656 \text{ W/m} \cdot \text{K}}{0.003\text{m}} (0.023) (14,053)^{4/5} (2.88)^{0.3} = 14,373 \text{ W/m}^2 \cdot \text{K}.$$

$$\Delta T_o = \Delta T_i \exp \left( -\frac{h_i \pi D_i L}{\dot{m} c_p} \right) = 70^\circ \text{C} \exp \left( -\frac{14,373 \frac{\text{W}}{\text{m}^2 \cdot \text{K}} \pi \times 0.003\text{m} \times 1\text{m}}{0.015 \text{ kg/s} \times 4186 \text{ J/kg} \cdot \text{K}} \right) = 8.1^\circ \text{C}$$

$$T_{m,o} = \Delta T_o + T_{s,i} = 8.1^\circ \text{C} + 27^\circ \text{C} = 35.1^\circ \text{C}. \quad <$$

(b) For the second case:  $T_{s,o} = 27^\circ \text{C}$  with

$$\Delta T_i = T_{m,i} - T_{s,o} = 70^\circ \text{C} \quad UA = \left[ (1/h_i \pi D_i L) + \ln(D_o/D_i)/2\pi \text{ kL} \right]^{-1}.$$

$$\text{With } \text{Re}_D = \frac{4 \dot{m}}{\pi D_i \mu} = \frac{4 \times 0.015 \text{ kg/s}}{\pi (0.003\text{m}) 289 \times 10^{-6} \text{ N} \cdot \text{s/m}^2} = 22,028$$

$$h_i = \frac{k}{D_i} 0.023 \text{Re}_D^{4/5} \text{Pr}^{0.3} = \frac{0.679 \text{ W/m} \cdot \text{K}}{0.003\text{m}} (0.023) (22,028)^{4/5} (1.80)^{0.3} = 18,511 \text{ W/m}^2 \cdot \text{K}.$$

It follows that

$$UA = \left[ \frac{1}{18,511 \pi \times 0.003} + \frac{\ln(0.004/0.003)}{2\pi(0.05)} \right]^{-1} = \left[ 5.73 \times 10^{-3} + 0.916 \right]^{-1} = 1.085 \text{ W/K}$$

and the outlet temperature is

$$\Delta T_o = 70^\circ \text{C} \exp \left( -\frac{1.085 \text{ W/K}}{0.015 \text{ kg/s} \times 4214 \text{ J/kg} \cdot \text{K}} \right) = 68.8^\circ \text{C}$$

$$T_{m,o} = \Delta T_o + T_{s,o} = 68.8^\circ \text{C} + 27^\circ \text{C} = 95.8^\circ \text{C}. \quad <$$

(c) For the third case:  $T_\infty = 27^\circ \text{C}$ ,  $\Delta T_i = T_{m,i} - T_\infty = 70^\circ \text{C}$  and

$$UA = \left[ (1/h_i \pi D_i L) + \ln(D_o/D_i)/2\pi \text{ kL} + (1/h_o \pi D_o L) \right]^{-1}$$

$$UA = \left[ 5.73 \times 10^{-3} + 0.916 + \frac{1}{5\pi(0.004)} \right]^{-1} = \left[ 5.73 \times 10^{-3} + 0.916 + 15.92 \right]^{-1} = 0.0594 \text{ W/K}$$

$$\Delta T_o = 70^\circ \text{C} \exp \left( -\frac{0.0594 \text{ W/K}}{0.015 \text{ kg/s} \times 4214 \text{ J/kg} \cdot \text{K}} \right) = 69.9^\circ \text{C}$$

$$T_{m,o} = \Delta T_o + T_\infty = 69.9^\circ \text{C} + 27^\circ \text{C} = 96.9^\circ \text{C}. \quad <$$

**COMMENTS:** Note that  $R_{\text{conv},o} \gg R_{\text{cond,insul}} \gg R_{\text{conv},i}$ ,

## PROBLEM 8.66

**KNOWN:** Dimensions of circular tube, applied constant heat flux, inlet temperature, mass flow rate, and expression for nanofluid viscosity.

**FIND:** Tube wall temperature at the tube exit for pure water and for a water-Al<sub>2</sub>O<sub>3</sub> nanofluid.

**SCHEMATIC:**

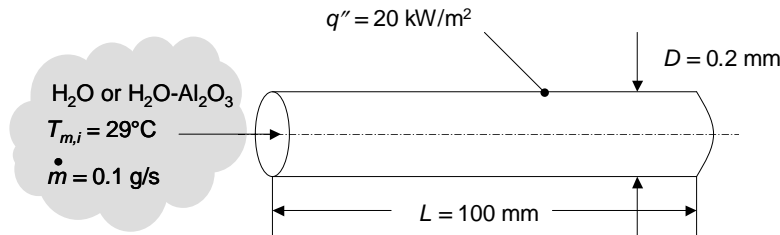

**ASSUMPTIONS:** (1) Constant properties.

**PROPERTIES:** Table A.4, water (300 K):  $\mu_{\text{bf}} = 855 \times 10^{-6} \text{ m}^2/\text{s}$ ,  $k_{\text{bf}} = 0.613 \text{ W/m}\cdot\text{K}$ ,  $c_{p,\text{bf}} = 4179 \text{ J/kg}\cdot\text{K}$ ,  $Pr_{\text{bf}} = 5.83$ . Example 2.2, nanofluid (300 K):  $\mu_{\text{nf}} = 962 \times 10^{-6} \text{ m}^2/\text{s}$ ,  $k_{\text{nf}} = 0.705 \text{ W/m}\cdot\text{K}$ ,  $c_{p,\text{nf}} = 3587 \text{ J/kg}\cdot\text{K}$ ,  $Pr_{\text{nf}} = \mu_{\text{nf}} c_{p,\text{nf}} / k_{\text{nf}} = 4.91$ .

**ANALYSIS:** The Reynolds number for the pure water

is  $Re_D = 4\dot{m} / \pi D \mu_{\text{bf}} = [4 \times (0.1/1000 \text{ kg/s})] / (\pi \times 0.0002 \text{ m} \times 855 \times 10^{-6} \text{ N}\cdot\text{s/m}^2) = 745$  and the flow is laminar. Similarly, the Reynolds number for the nanofluid is  $Re_{D,\text{nf}} = 662$ . The hydrodynamic entrance length for the pure water is  $x_{fd,h} = 0.05 Re_D D = 0.05 \times 745 \times 0.2/1000 \text{ m} = 7.45 \times 10^{-3} \text{ m} = 7.45 \text{ mm}$  and the flow at the tube exit is hydrodynamically fully developed. Similarly, the hydrodynamic entrance length for the nanofluid is  $x_{fd,h,\text{nf}} = 6.62 \times 10^{-3} \text{ m} = 6.62 \text{ mm}$  and the flow at the tube exit is also hydrodynamically fully developed. For the pure water, the thermal entrance length is  $x_{fd,t} = x_{fd,h} Pr_{\text{bf}} = 7.45 \text{ mm} \times 5.83 = 43.4 \text{ mm}$ , while for the nanofluid  $x_{fd,t,\text{nf}} = x_{fd,h,\text{nf}} Pr_{\text{nf}} = 6.62 \text{ mm} \times 4.91 = 32.5 \text{ mm}$  and the flow is also thermally fully-developed at the tube exit for both fluids.

For constant heat flux conditions, the local Nusselt number in the fully-developed region is  $Nu_D = 4.36$ . Therefore, the local heat transfer coefficient at the tube exit is:

$$\text{Pure fluid: } h_{\text{bf}} = Nu_D k_{\text{bf}} / D = 4.36 \times 0.613 \text{ W/m}\cdot\text{K} / (0.2/1000 \text{ m}) = 13,360 \text{ W/m}^2\cdot\text{K}.$$

$$\text{Nanofluid: } h_{\text{nf}} = Nu_D k_{\text{nf}} / D = 4.36 \times 0.705 \text{ W/m}\cdot\text{K} / (0.2/1000 \text{ m}) = 15,370 \text{ W/m}^2\cdot\text{K}.$$

Applying Eq. (8.40) to the pure fluid yields

$$T_{m,o} = T_{m,i} + \frac{q'' \pi D}{\dot{m} c_{p,\text{bf}}} L = 29^\circ\text{C} + \frac{20,000 \text{ W/m}^2 \pi (0.2/1000 \text{ m})}{(0.1/1000 \text{ kg/s}) \times (4179 \text{ J/kg}\cdot\text{K})} 0.1 \text{ m} = 29^\circ\text{C} + 3.00^\circ\text{C} = 32.00^\circ\text{C}$$

whereas applying Eq. (8.40) to the nanofluid results in

$$T_{m,o,\text{nf}} = T_{m,i} + \frac{q'' \pi D}{\dot{m} c_{p,\text{nf}}} L = 29^\circ\text{C} + \frac{20,000 \text{ W/m}^2 \pi (0.2/1000 \text{ m})}{(0.1/1000 \text{ kg/s}) \times (3587 \text{ J/kg}\cdot\text{K})} 0.1 \text{ m} = 29^\circ\text{C} + 3.50^\circ\text{C} = 32.50^\circ\text{C}$$

Continued...

### PROBLEM 8.66 (Cont.)

From Eq. (8.27) the wall temperature at the outlet of the tube carrying the pure water is,

$$T_s(x=L) = T_{m,o} + q'' / h_{bf} = 32.00^\circ\text{C} + 20,000\text{W/m}^2 / 13,360 \text{ W/m}^2 \cdot \text{K} = 32^\circ\text{C} + 1.50^\circ\text{C} = 33.50^\circ\text{C} <$$

Similarly for the nanofluid,

$$\begin{aligned} T_{s,nf}(x=L) &= T_{m,o,nf} + q'' / h_{nf} < \\ &= 32.50^\circ\text{C} + 20,000\text{W/m}^2 / 15,370 \text{ W/m}^2 \cdot \text{K} = 32.50^\circ\text{C} + 1.30^\circ\text{C} = 33.80^\circ\text{C} \end{aligned}$$

**COMMENTS:** Although the nanofluid provides a larger thermal conductivity and, in turn, a larger convective heat transfer coefficient relative to the pure water, the wall temperature at the tube outlet with the nanofluid exceeds that of the wall temperature using pure water. This is due to the reduction of the specific heat upon addition of the nanoparticles to the pure water and the associated increase in the outlet mean temperature. Hence, careful consideration of the flow conditions must be made in order to determine whether wall temperatures will decrease or increase with use of the nanofluid.



## PROBLEM 8.67

**KNOWN:** Dimensions of circular tube, applied constant heat flux, inlet temperature, mass flow rate.

**FIND:** Tube wall temperature at the tube exit for pure water and for a water-Al<sub>2</sub>O<sub>3</sub> nanofluid.

**SCHEMATIC:**

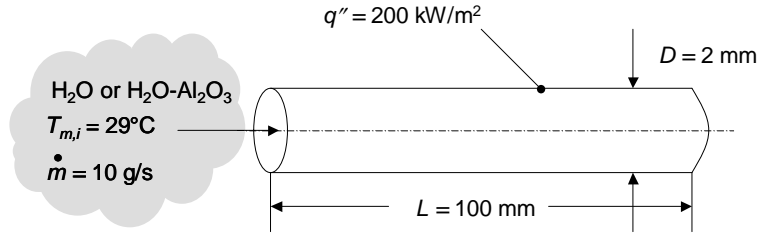

**ASSUMPTIONS:** (1) Constant properties.

**PROPERTIES:** Table A.4, water (300 K):  $\mu_{bf} = 855 \times 10^{-6} \text{ m}^2/\text{s}$ ,  $k_{bf} = 0.613 \text{ W/m}\cdot\text{K}$ ,  $c_{p,bf} = 4179 \text{ J/kg}\cdot\text{K}$ ,  $Pr_{bf} = 5.83$ . Example 2.2, nanofluid (300 K):  $\mu_{nf} = 962 \times 10^{-6} \text{ m}^2/\text{s}$ ,  $k_{nf} = 0.705 \text{ W/m}\cdot\text{K}$ ,  $c_{p,nf} = 3587 \text{ J/kg}\cdot\text{K}$ ,  $Pr_{nf} = 4.91$ .

**ANALYSIS:** The Reynolds number for the pure water

is  $Re_D = 4\dot{m} / \pi D \mu_{bf} = [4 \times (10/1000 \text{ kg/s})] / (\pi \times 0.002 \text{ m} \times 855 \times 10^{-6} \text{ N}\cdot\text{s/m}^2) = 7450$  and the flow is turbulent. Similarly, the Reynolds number for the nanofluid is  $Re_{D,nf} = 6620$ . Since  $L/D = 100/2 = 50$ , the flow is fully-developed at the tube exit for both fluids.

The local Nusselt number is evaluated using the Gnielinski correlation. For pure water, Eq. (8.21) yields,  $f_{bf} = (0.790 \ln(7450) - 1.64)^{-2} = 0.0342$  while for the nanofluid,  $f_{nf} = (0.790 \ln(6620) - 1.64)^{-2} = 0.0355$ . The Gnielinski correlation yields, for the pure fluid

$$Nu_{D,bf} = \frac{(0.0342/8)(7450 - 1000)5.83}{1 + 12.7(0.0342/8)^{1/2}(5.83^{2/3} - 1)} = 56.24$$

while for the nanofluid,

$$Nu_{D,nf} = \frac{(0.0355/8)(6620 - 1000)4.91}{1 + 12.7(0.0355/8)^{1/2}(4.91^{2/3} - 1)} = 47.08$$

Hence,  $h_{bf} = Nu_{D,bf} k_{bf} / D = 56.24(0.613 \text{ W/m}\cdot\text{K}) / 0.002 \text{ m} = 17,240 \text{ W/m}^2\cdot\text{K}$  and  $h_{nf} = Nu_{D,bf} k_{nf} / D = 47.08(0.705 \text{ W/m}\cdot\text{K}) / 0.002 \text{ m} = 16,600 \text{ W/m}^2\cdot\text{K}$ .

Applying Eq. (8.40) to the pure fluid yields

$$T_{m,o} = T_{m,i} + \frac{q'' \pi D}{\dot{m} c_{p,bf}} L = 29^\circ\text{C} + \frac{200,000 \text{ W/m}^2 \pi (2/1000 \text{ m})}{(10/1000 \text{ kg/s}) \times (4179 \text{ J/kg}\cdot\text{K})} 0.1 \text{ m} = 29^\circ\text{C} + 3.00^\circ\text{C} = 32.00^\circ\text{C}$$

whereas applying Eq. (8.40) to the nanofluid results in

Continued...

### PROBLEM 8.67 (Cont.)

$$T_{m,o,nf} = T_{m,i} + \frac{q''\pi D}{\dot{m}c_{p,nf}}L = 29^\circ\text{C} + \frac{200,000 \text{ W/m}^2\pi(2/1000 \text{ m})}{(10/1000 \text{ kg/s})\times(3587 \text{ J/kg}\cdot\text{K})}0.1 \text{ m} = 29^\circ\text{C} + 3.50^\circ\text{C} = 32.50^\circ\text{C}$$

From Eq. (8.27) the wall temperature at the outlet of the tube carrying the pure water is,

$$\begin{aligned} T_s(x=L) &= T_{m,o} + q''/h_{bf} \\ &= 32.00^\circ\text{C} + 200,000\text{W/m}^2 / 17,240 \text{ W/m}^2 \cdot \text{K} = 32.00^\circ\text{C} + 11.61^\circ\text{C} = 43.61^\circ\text{C} \end{aligned} \quad <$$

Similarly for the nanofluid,

$$\begin{aligned} T_{s,nf}(x=L) &= T_{m,o,nf} + q''/h_{nf} \\ &= 32.50^\circ\text{C} + 200,000\text{W/m}^2 / 16,600 \text{ W/m}^2 \cdot \text{K} = 32.50^\circ\text{C} + 12.05^\circ\text{C} = 44.55^\circ\text{C} \end{aligned} \quad <$$

**COMMENT:** The nanofluid provides a larger thermal conductivity but a smaller convective heat transfer coefficient relative to the pure water. If the objective is to minimize the wall temperature at the outlet of the tube, the nanofluid is *not* the appropriate selection. The wall temperature at the tube outlet may be greater than, less than, or equal to the wall temperature associated with use of pure water, depending on the tube geometry and flow rate.

## PROBLEM 8.68

**KNOWN:** Reaction vessel with process fluid at 75°C cooled by water at 27°C and 0.12 kg/s through 15 mm tube. High convection coefficient on outside of tube ( $3000 \text{ W/m}^2 \cdot \text{K}$ ) created by vigorous stirring.

**FIND:** (a) Maximum heat transfer rate if outlet temperature of water cannot exceed  $T_{m,o} = 47^\circ\text{C}$ , and (b) Required tube length.

**SCHEMATIC:**

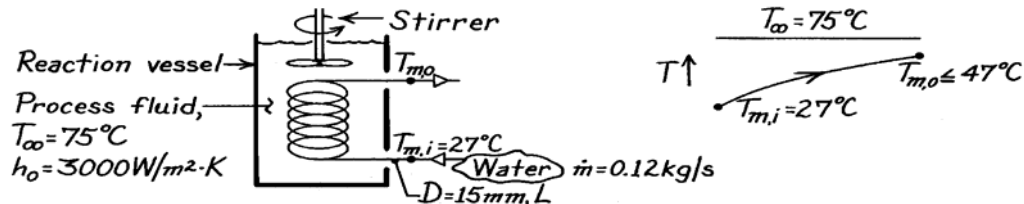

**ASSUMPTIONS:** (1) Steady-state conditions, (2) Incompressible liquid with negligible viscous dissipation, (3) Negligible thermal resistance of tube wall.

**PROPERTIES:** Table A-6, Water ( $\bar{T}_m = (47 + 27)^\circ\text{C}/2 = 310\text{K}$ ):  $\rho = 1/\nu_f = 993.1 \text{ kg/m}^3$ ,  $c_p = 4178 \text{ J/kg}\cdot\text{K}$ ,  $\mu = 695 \times 10^{-6} \text{ N}\cdot\text{s/m}^2$ ,  $k = 0.628 \text{ W/m}\cdot\text{K}$ ,  $\text{Pr} = 4.62$ .

**ANALYSIS:** (a) From an overall energy balance on the tube with  $T_{m,o} = 47^\circ\text{C}$ ,

$$q_{\max} = \dot{m} c_p (T_{m,o} - T_{m,i}) = 0.12 \text{ kg/s} \times 4178 \text{ J/kg}\cdot\text{K} (47 - 27)^\circ\text{C} = 10,027 \text{ W} \quad <$$

(b) For the constant surface temperature heating condition, from Eq. 8.45a,

$$\frac{T_\infty - T_{m,o}}{T_\infty - T_{m,i}} = \exp\left(-\frac{PL}{\dot{m} c_p} \bar{U}\right) \quad \text{where} \quad 1/U = 1/\bar{h}_o + 1/\bar{h}_i.$$

For internal flow in the tube, find

$$\text{Re}_D = \frac{4\dot{m}}{\pi D \mu} = \frac{4 \times 0.12 \text{ kg/s}}{\pi \times 0.015 \text{ m} \times 695 \times 10^{-6} \text{ N}\cdot\text{s/m}^2} = 14,656$$

and the flow is turbulent. Assuming fully developed flow, use the Dittus-Boelter correlation with  $n = 0.4$  (heating),

$$\text{Nu}_D = h_i D/k = 0.023 \text{Re}_D^{4/5} \text{Pr}^{0.4}$$

$$h_i = [0.628 \text{ W/m}\cdot\text{K}/0.015 \text{ m}] \times 0.023 (14,656)^{4/5} (4.62)^{0.4} = 3822 \text{ W/m}^2 \cdot \text{K}.$$

Hence,  $1/U = [1/3000 + 1/3822] \text{ m}^2 \cdot \text{K/W}$  or  $U = 1680 \text{ W/m}^2 \cdot \text{K}$ . From the energy balance relation with  $P = \pi D$ , find

$$\frac{(75 - 47)^\circ\text{C}}{(75 - 27)^\circ\text{C}} = \exp\left(-\frac{\pi (0.015 \text{ m}) L \times 1680 \text{ W/m}^2 \cdot \text{K}}{0.12 \text{ kg/s} \times 4178 \text{ J/kg}\cdot\text{K}}\right) \quad L = 3.4 \text{ m} \quad <$$

**COMMENTS:** Note that  $L/D = 227$  and the fully developed flow assumption is appropriate.

## PROBLEM 8.69

**KNOWN:** Water flowing through a tube heated by cross flow of a hot gas. Required to heat water from 15 to 35°C with a flow rate of 0.2 kg/s.

**FIND:** Design graphs to demonstrate acceptable combinations of tube diameter ( $D = 20, 30$  or  $40$  mm), tube length ( $L = 3, 4$  or  $6$  m) and hot gas velocity ( $20 \leq V \leq 40$  m/s) and temperature ( $T_\infty = 250, 375$  or  $500^\circ\text{C}$ ).

**SCHEMATIC:**

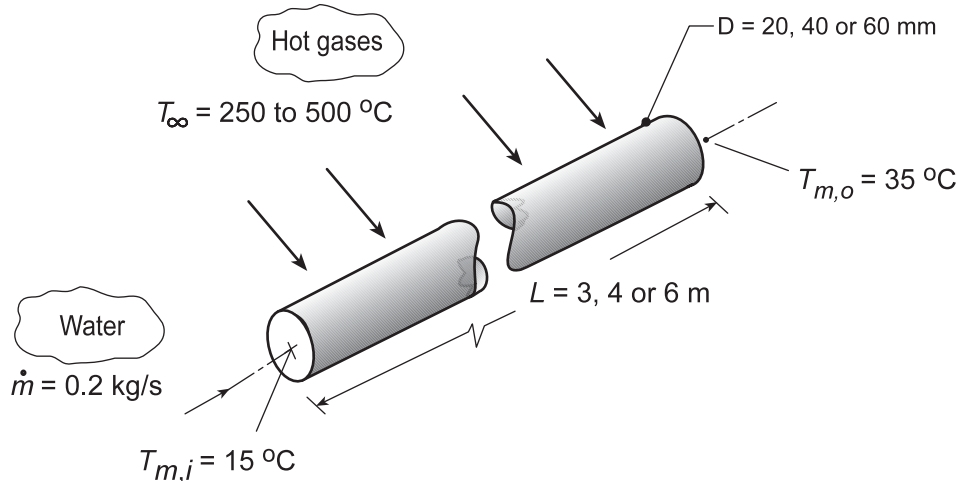

**ASSUMPTIONS:** (1) Steady-state conditions, (2) Water is incompressible liquid with negligible viscous dissipation, (3) Fully developed flow and thermal conditions for internal flow, (4) Properties of the hot gas are those of atmospheric air, and (5) Negligible tube wall thermal resistance.

**PROPERTIES:** Table A.6, Water ( $\bar{T}_m = (15 + 35)^\circ\text{C}/2 = 298\text{K}$ ); Table A.4, Air ( $\bar{T}_f = (\bar{T}_s + T_\infty)/2$ , 1 atm).

**ANALYSIS:** *Method of Analysis:* The tube having internal flow of water with cross flow of hot gas can be analyzed by the energy balance relation, Eq. 8.45a

$$\frac{T_\infty - T_{m,o}}{T_\infty - T_{m,i}} = \exp\left(-\frac{(\pi DL)}{\dot{m}c_p} \bar{U}\right) \quad (1)$$

where the overall coefficient  $\bar{U}$  is

$$\bar{U} = \left(1/\bar{h}_i + 1/\bar{h}_o\right)^{-1} \quad (2)$$

*Estimation of the internal flow coefficient,  $\bar{h}_i$ :* Evaluating water properties at the average mean fluid temperature

$$\bar{T}_m = (T_{m,i} + T_{m,o})/2, \quad (3)$$

characterize the flow with the Reynolds number,

$$\text{Re}_{D,i} = \frac{4\dot{m}}{(\pi D\mu)} \quad (4)$$

and assuming the flow to be both turbulent and fully developed ( $L/D > 3\text{m}/0.07\text{m} = 42$ ), use the Dittus-Boelter correlation, Eq. 8.60, to evaluate  $\bar{h}_i$ ,

Continued...

**PROBLEM 8.69 (Cont.)**

$$\overline{\text{Nu}}_{D,i} = \frac{\overline{h}_i D}{k_i} = 0.023 \text{Re}_{D,i}^{0.8} \text{Pr}^{0.4} \quad (5)$$

Estimation of the external flow coefficient,  $\overline{h}_o$ : Evaluating gas (air) properties at the average film temperature

$$\overline{T}_f = (\overline{T}_s + T_\infty)/2 \quad (6)$$

where  $\overline{T}_s$  is the average tube wall temperature (see Eq. (9)), characterize the flow

$$\text{Re}_{D,o} = \frac{VD}{\nu} \quad (7)$$

and use the Churchill-Bernstein correlation, Eq. 7.54, for cross-flow over a cylinder,

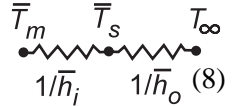
$$\text{Nu}_{D,o} = \frac{\overline{h}_o D}{k_o} = 0.3 + \frac{0.62 \text{Re}_{D,o}^{1/2} \text{Pr}_o^{1/3}}{\left[1 + (0.4/\text{Pr}_o)^{2/3}\right]^{1/4}} \left[1 + \left(\frac{\text{Re}_{D,o}}{282,000}\right)^{5/8}\right]^{4/5} \quad (8)$$

The average tube wall temperature,  $\overline{T}_s$ , follows from the thermal circuit

$$\frac{\overline{T}_m - \overline{T}_s}{1/\overline{h}_i} = \frac{\overline{T}_s - T_\infty}{1/\overline{h}_o} \quad (9)$$

*The IHT Workspace:* Using the *Correlation Tools for Internal Flow (Turbulent flow)*, and *External Flow (Flow over a Cylinder)* and *Properties for Air and Water*, along with the appropriate energy balances and rate equations, the heater-tube system can be analyzed.

*The Design Strategy:* We have chosen to generate the design information in the following manner: for a specified gas temperature,  $T_\infty$ , plot the required length  $L$  (limiting the scale to  $3 \leq L \leq 6\text{m}$ ) as a function of gas velocity  $V$  ( $20 \leq V \leq 40\text{ m/s}$ ) for tube diameters of  $D = 20, 30$  and  $40\text{ mm}$ . Three design graphs corresponding to  $T_\infty = 250, 375$  and  $500^\circ\text{C}$  were generated and are shown on the next page.

**COMMENTS:** (1) The collection of design graphs will allow the contractor to select appropriate combinations of tube  $D$  and  $L$  and gas stream parameters ( $T_\infty$  and  $V$ ) to achieve the required water heating.

(2) Note from the design graphs that with  $T_\infty = 250^\circ\text{C}$ , the required heating of the water can be achieved only with a 40-mm diameter by 6 m length tube with gas velocities greater than 32 m/s. This configuration represents a worst case condition of largest tube parameters and highest gas velocity.

(3) Which operating conditions,  $T_\infty = 375$  or  $500^\circ\text{C}$ , provides the contractor with more options in selecting combinations of tube parameters and gas velocities? What are the trade-offs in operating at 375 or  $500^\circ\text{C}$ ? Consider such features as tube life, tubing costs and fan requirements.

(4) The Reynolds numbers for the internal flow are approximately 7,100, 9,460 and 14,200 for the tube diameters of 20, 30 and 40 mm. For the larger tube sizes, the Reynolds numbers are below 10,000, the usual lower limit for turbulent flow. The Gnielinski correlation would be more accurate under these conditions.

Continued...

## PROBLEM 8.69 (Cont.)

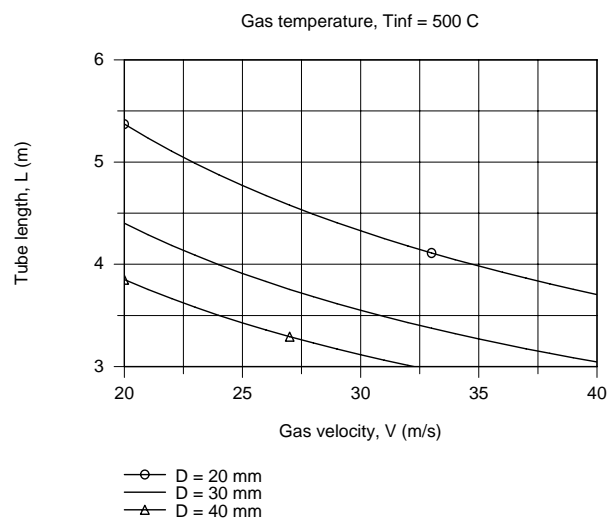
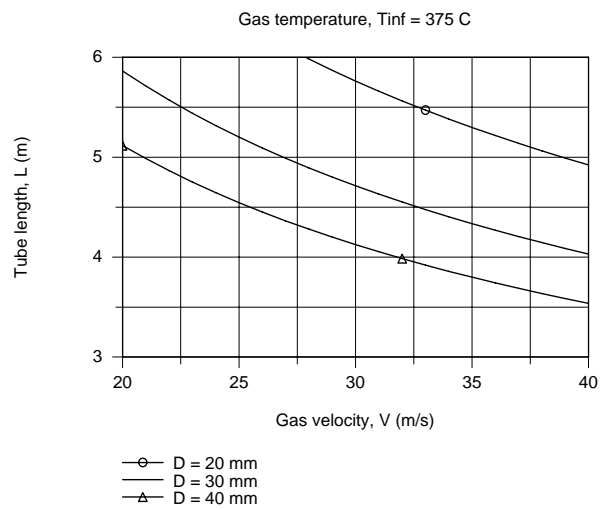
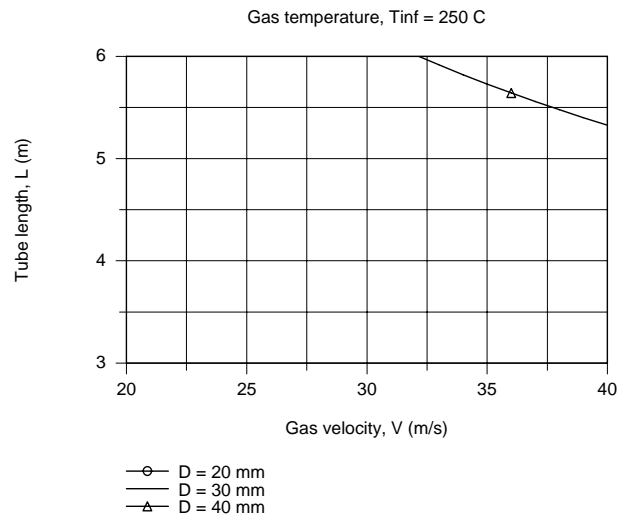

### PROBLEM 8.70

**KNOWN:** Exhaust gases at 200°C and mass rate 0.03 kg/s enter tube of diameter 6 mm and length 20 m. Tube experiences cross-flow of autumn winds at 15°C and 5 m/s.

**FIND:** Average heat transfer coefficients for (a) exhaust gas inside tube and (b) air flowing across outside of tube, (c) Estimate overall coefficient and exhaust gas temperature at outlet of tube.

**SCHEMATIC:**

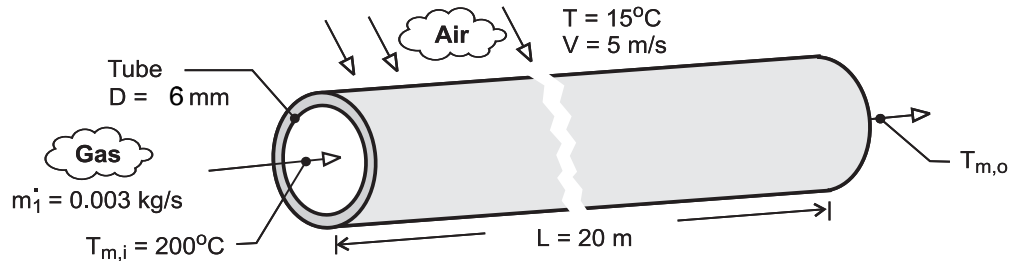

**ASSUMPTIONS:** (1) Steady-state conditions, (2) Ideal gas with negligible viscous dissipation and pressure variation, (3) Negligible tube wall resistance, (4) Exhaust gas properties are those of air, (5) Negligible radiation effects.

**PROPERTIES:** Table A-4, Air (assume  $T_{m,o} \approx 15^\circ\text{C}$ , hence  $\bar{T}_m = 380\text{ K}$ , 1 atm):  $c_p = 1012\text{ J/kg}\cdot\text{K}$ ,  $k = 0.0323\text{ W/m}\cdot\text{K}$ ,  $\mu = 221.6 \times 10^{-7}\text{ N}\cdot\text{s/m}^2$ ,  $\text{Pr} = 0.694$ ; Air ( $T_\infty = 15^\circ\text{C} = 288\text{ K}$ , 1 atm):  $k = 0.0253\text{ W/m}\cdot\text{K}$ ,  $\nu = 14.82 \times 10^{-6}\text{ m}^2/\text{s}$ ,  $\text{Pr} = 0.710$ ; Air ( $\bar{T}_s \approx 90^\circ\text{C} = 363\text{ K}$ , 1 atm):  $\text{Pr} = 0.698$ .

**ANALYSIS:** (a) For the *internal flow* through the tube assuming a value for  $T_{m,o} = 15^\circ\text{C}$ , find

$$\text{Re}_D = \frac{4\dot{m}}{\pi D\mu} = \frac{4 \times 0.003\text{ kg/s}}{\pi \times 0.006\text{ m} \times 221.6 \times 10^{-7}\text{ N}\cdot\text{s/m}^2} = 2.873 \times 10^4.$$

Hence the flow is turbulent and, since  $L/D \gg 10$ , fully developed. Using the Dittus-Doelter correlation with  $n = 0.3$ ,

$$\text{Nu}_D = 0.023\text{Re}_D^{0.8}\text{Pr}^{0.3} = 0.023(2.873 \times 10^4)^{0.8}(0.694)^{0.3} = 76.0$$

$$h_i = \text{Nu} \cdot k/D = 76.0 \times 0.0323\text{ W/m}\cdot\text{K}/0.006\text{ m} = 409\text{ W/m}^2 \cdot \text{K}. \quad <$$

(b) For *cross-flow* over the circular tube, find using thermophysical properties at  $T_\infty$ ,

$$\text{Re}_D = \frac{VD}{\nu} = \frac{5\text{ m/s} \times 0.006\text{ m}}{14.82 \times 10^{-6}\text{ m}^2/\text{s}} = 2024$$

and using the Zukauskus correlation with  $C = 0.26$ ,  $m = 0.6$ , and  $n = 0.37$ ,

$$\text{Nu}_D = C\text{Re}_D^m\text{Pr}^n(\text{Pr}/\text{Pr}_s)^{1/4} = 0.26(2024)^{0.6}0.710^{0.37}(0.710/0.698)^{0.25} = 22.2$$

where  $\text{Pr}_s$  is evaluated at  $\bar{T}_s$ . Hence,

$$h_o = \text{Nu}_D \cdot k/D = 22.2 \times 0.0253\text{ W/m}\cdot\text{K}/0.006\text{ m} = 93.4\text{ W/m}^2 \cdot \text{K}. \quad <$$

Continued ...

**PROBLEM 8.70 (Cont.)**

(c) Assuming the thermal resistance of the tube wall is negligible,

$$\frac{1}{U} = \frac{1}{h_o} + \frac{1}{h_i} = \left( \frac{1}{93.4} + \frac{1}{409} \right) \text{m}^2 \cdot \text{K/W} \quad U = 76.1 \text{ W/m}^2 \cdot \text{K}. \quad <$$

The gas outlet temperature can be determined from the expression where  $P = \pi D$ .

$$\frac{T_\infty - T_{m,o}}{T_\infty - T_{m,i}} = \exp\left(-\frac{PUL}{\dot{m} c_p}\right) = \exp\left(-\frac{\pi \times 0.006 \text{ m} \times 76.1 \text{ W/m}^2 \cdot \text{K} \times 20 \text{ m}}{0.003 \text{ kg/s} \times 1012 \text{ J/kg} \cdot \text{K}}\right)$$

$$\frac{15 - T_{m,o}}{(15 - 200)^\circ \text{C}} = 7.9 \times 10^{-5}$$

$$T_{m,o} = 15^\circ \text{C}. \quad <$$

**COMMENTS:** (1) With  $T_{m,o} = 15^\circ \text{C}$ , find  $\bar{T}_m = 380 \text{ K}$ ; hence thermophysical properties for the internal flow correlation were evaluated at a reasonable temperature. Note that the gas is cooled from  $200^\circ \text{C}$  to the ambient air temperature,  $T_{m,o} = T_\infty$ , over the 20-m length!

(2) The average wall surface temperature,  $\bar{T}_s$ , follows from an energy balance on the wall surface,

$$\frac{\bar{T}_m - \bar{T}_s}{\bar{T}_s - T_{\text{inf}}} = \frac{h_i}{h_o}$$

and substituting numerical values, find  $\bar{T}_s = 90^\circ \text{C} = 363 \text{ K}$ , the value we assumed for evaluating  $Pr_s$ . Can you draw a thermal circuit to represent this energy balance relation?

(3) When using the Zukauskus correlation, it is reasonable to evaluate  $Pr_s$  at the  $\bar{T}_m$  for the first trial. For gases the assumption is a safe one, but for liquids, especially oils, additional trials will be required since the Prandtl number may be strongly dependent upon temperature.



## PROBLEM 8.71

**KNOWN:** Superheated steam passing through thin-walled pipe covered with insulation and suspended in a quiescent air.

**FIND:** Point along pipe surface where steam will begin condensing ( $x_1$ ).

**SCHEMATIC:**

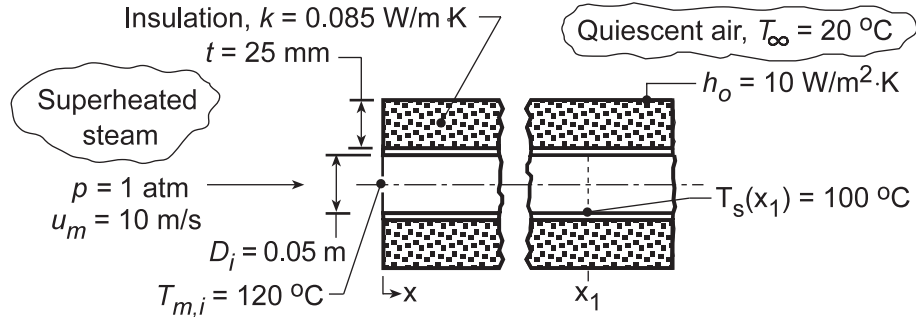

**ASSUMPTIONS:** (1) Steady-state conditions, (2) Steam is ideal gas with negligible viscous dissipation and pressure variation, (3) Steam properties may be approximated as those corresponding to saturated conditions.

**PROPERTIES:** Table A.6, Saturated steam ( $\bar{T}_m = (100 + 120)^\circ\text{C}/2 = 110^\circ\text{C} \approx 385 \text{ K}$ ):  $\rho_g = 0.876 \text{ kg/m}^3$ ,  $c_{p,g} = 2080 \text{ J/kg}\cdot\text{K}$ ,  $\mu_g = 12.49 \times 10^{-6} \text{ N}\cdot\text{s/m}^2$ ,  $k_g = 0.0258 \text{ W/m}\cdot\text{K}$ ,  $\text{Pr}_g = 1.004$ .

**ANALYSIS:** From Eq. 8.45a, where  $T_{m,x}$  is the mean temperature at any distance  $x$ ,

$$\frac{T_\infty - T_{m,x}}{T_\infty - T_{m,i}} = \exp\left(-\frac{Px}{\dot{m}c_p} U\right) \quad (1)$$

The mass flow rate, with  $A_c = \pi D^2/4$ , is

$$\dot{m} = \rho_g A_c u_m = 0.876 \text{ kg/m}^3 \left( \pi (0.050 \text{ m})^2 / 4 \right) \times 10 \text{ m/s} = 0.0172 \text{ kg/s}$$

and for the internal flow,

$$\text{Re}_D = \frac{4\dot{m}}{\pi D \mu} = \frac{4 \times 0.0172 \text{ kg/s}}{\pi (0.050 \text{ m}) \times 12.49 \times 10^{-6} \text{ N}\cdot\text{s/m}^2} = 35,068.$$

Assuming the flow is fully developed, the Dittus-Boelter correlation yields

$$\text{Nu}_D = \frac{h_i D}{k} = 0.023 (35,068)^{4/5} (1.004)^{0.3} = 99.58$$

$$h_i = \frac{0.0258 \text{ W/m}\cdot\text{K}}{0.050 \text{ m}} \times 99.58 = 51.4 \text{ W/m}^2 \cdot \text{K}$$

Hence, from Eq. 3.36, the overall coefficient for the inner surface is

$$U_i = \left[ \frac{1}{h_i} + \frac{D_i \ln(D_o/D_i)}{2k} + \frac{D_i}{D_o} \frac{1}{h_o} \right]^{-1} = \left[ \frac{1}{51.4} + \frac{(0.050) \ln(0.100/0.050)}{2 \times 0.085} + \frac{0.050}{0.100} \frac{1}{10} \right]^{-1} \text{ W/m}^2 \cdot \text{K}$$

$$U_i = \left[ 1.946 \times 10^{-2} + 2.039 \times 10^{-1} + 5.000 \times 10^{-2} \right]^{-1} = 3.66 \text{ W/m}^2 \cdot \text{K}.$$

Continued...

### PROBLEM 8.71 (Cont.)

With condensation occurring when the surface temperature reaches  $100^\circ\text{C}$ , the corresponding value of  $T_m$  may be determined from the local ( $x = x_1$ ) requirement that  $U_i (\pi D_i) [T_m(x_1) - T_\infty]$

$= h_i (\pi D_i) [T_m(x_1) - T_s]$ . Hence,

$$T_m(x_1) = \frac{T_\infty - (h_i/U_i)T_s}{1 - (h_i/U_i)} = \frac{20 - (51.4/3.66)100^\circ\text{C}}{1 - (51.4/3.66)} = 106^\circ\text{C}$$

The distance at which the mean steam temperature is  $106^\circ\text{C}$  can then be estimated from Eq. (1), where  $P = \pi D_i$  and  $U = U_i$ ,

$$\frac{(20 - 106)^\circ\text{C}}{(20 - 120)^\circ\text{C}} = \exp\left(-\frac{\pi(0.050\text{ m})3.66\text{ W/m}^2 \cdot \text{K}(x_1)}{0.0172\text{ kg/s} \times 2080\text{ J/kg} \cdot \text{K}}\right)$$

$$x_1 = 9.3\text{ m}$$

<

**COMMENTS:** Note that condensation first occurs at the location for which the surface, and not the mean, temperature reaches  $100^\circ\text{C}$ .

## PROBLEM 8.72

**KNOWN:** Length and diameter of air conditioning duct. Inlet temperature of chilled air. Temperature and convection coefficient associated with outer air. Chilled air flowrate.

**FIND:** Chilled air exit temperature and heat flow rate.

**SCHEMATIC:**

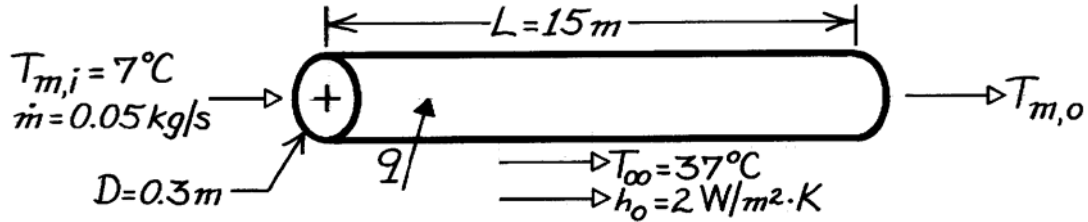

**ASSUMPTIONS:** (1) Steady-state conditions, (2) Negligible tube wall conduction resistance, (3) Ideal gas with negligible viscous dissipation, pressure variation, and axial conduction.

**PROPERTIES:** Table A-4, Air (300 K, 1 atm):  $c_p = 1007 \text{ J/kg}\cdot\text{K}$ ,  $\mu = 184.6 \times 10^{-7} \text{ kg/s}\cdot\text{m}$ ,  $k = 0.0263 \text{ W/m}\cdot\text{K}$ ,  $Pr = 0.707$ .

**ANALYSIS:** The exit temperature may be obtained from Eq. 8.45a, where

$$\bar{U} = \left( h_i^{-1} + h_o^{-1} \right)^{-1}$$

$$\text{With } Re_D = \left( 4\dot{m} / \pi D \mu \right) = \frac{4(0.05 \text{ kg/s})}{\pi(0.3 \text{ m})184.6 \times 10^{-7} \text{ kg/s}\cdot\text{m}} = 11,495$$

the flow is turbulent and, assuming fully developed conditions over the entire length, the Dittus-Boelter correlation yields

$$Nu_D = 0.023 Re_D^{4/5} Pr^{0.4} = 0.023(11,495)^{4/5} (0.707)^{0.4} = 35.5$$

$$h_i = Nu_D (k/D) = 35.5(0.0263 \text{ W/m}\cdot\text{K}/0.3 \text{ m}) = 3.11 \text{ W/m}^2 \cdot \text{K}$$

$$\text{and } \bar{U} = \left( 3.11^{-1} + 2.0^{-1} \right)^{-1} \left( \text{W/m}^2 \cdot \text{K} \right) = 1.22 \text{ W/m}^2 \cdot \text{K}.$$

$$\text{Eq. 8.45a yields } T_{m,o} = T_{\infty} - (T_{\infty} - T_{m,i}) \exp \left[ -(\pi DL / \dot{m} c_p) \bar{U} \right]$$

$$T_{m,o} = 37^{\circ}\text{C} - 30^{\circ}\text{C} \exp \left[ -\frac{\pi(0.3 \text{ m})15 \text{ m} \left( 1.22 \text{ W/m}^2 \cdot \text{K} \right)}{0.05 \text{ kg/s} (1007 \text{ J/kg}\cdot\text{K})} \right] = 15.7^{\circ}\text{C} \quad <$$

and the heat rate is

$$q = \dot{m} c_p (T_{m,o} - T_{m,i}) = 0.05 \text{ kg/s} (1007 \text{ J/kg}\cdot\text{K}) (8.7^{\circ}\text{C}) = 438 \text{ W}. \quad <$$

**COMMENTS:** (1) The temperature rise of the chilled air is excessive, and the outer surface of the duct should be insulated to reduce  $\bar{U}$  and thereby  $T_{m,o}$  and  $q$ . (2) The temperature selected for evaluating air properties was not very accurate. Air properties should be evaluated at  $\bar{T}_m = (T_{m,o} + T_{m,i}) / 2 \approx 285 \text{ K}$ .

### PROBLEM 8.73

**KNOWN:** Flow conditions associated with water passing through a pipe and air flowing over the pipe.

**FIND:** (a) Differential equation which determines the variation of the mixed-mean temperature of the water, (b) Heat transfer per unit length of pipe at the inlet and outlet temperature of the water.

**SCHEMATIC:**

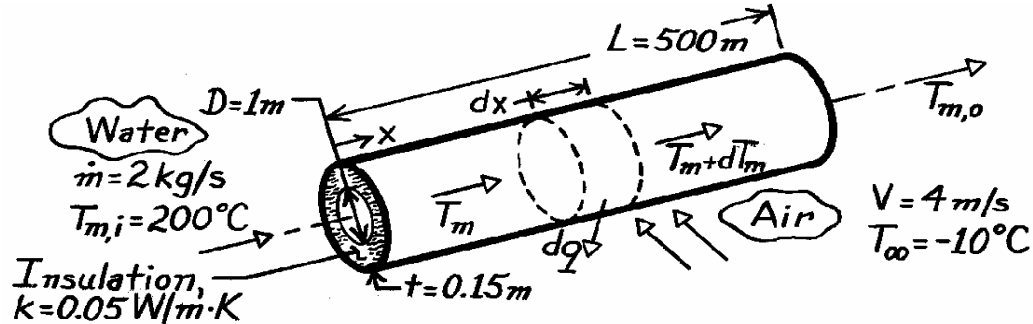

**ASSUMPTIONS:** (1) Negligible temperature drop across the pipe wall, (2) Negligible radiation exchange between outer surface of insulation and surroundings, (3) Fully developed flow throughout pipe, (4) Water is incompressible liquid with negligible viscous dissipation.

**PROPERTIES:** Table A-6, Water ( $T_{m,i} = 200^\circ\text{C}$ ):  $c_{p,w} = 4500 \text{ J/kg}\cdot\text{K}$ ,  $\mu_w = 134 \times 10^{-6} \text{ N}\cdot\text{s/m}^2$ ,  $k_w = 0.665 \text{ W/m}\cdot\text{K}$ ,  $Pr_w = 0.91$ ; Table A-4, Air ( $T_\infty = -10^\circ\text{C}$ ):  $\nu_a = 12.6 \times 10^{-6} \text{ m}^2/\text{s}$ ,  $k_a = 0.023 \text{ W/m}\cdot\text{K}$ ,  $Pr_a = 0.71$ ,  $Pr_s \approx 0.7$ .

**ANALYSIS:** (a) Following the development of Section 8.3.1 and applying Eq. 1.12e to a differential element in the water, we obtain

$$dq = -\dot{m} c_{p,w} dT_m$$

where 
$$dq = U_i dA_i (T_m - T_\infty) = U_i \pi D dx (T_m - T_\infty).$$

Substituting into the energy balance, it follows that

$$\frac{dT_m}{dx} = -\frac{U_i \pi D}{\dot{m} c_p} (T_m - T_\infty). \quad (1)$$

The overall heat transfer coefficient based on the inside surface area may be evaluated from Eq. 3.36 which, for the present conditions, reduces to

$$U_i = \frac{1}{\frac{1}{h_i} + \frac{D}{2k} \ln\left(\frac{D+2t}{D}\right) + \frac{D}{D+2t} \frac{1}{h_o}}. \quad (2)$$

For the *inner water flow*, Eq. 8.6 gives

$$Re_D = \frac{4 \dot{m}}{\pi D \mu_w} = \frac{4 \times 2 \text{ kg/s}}{\pi (1 \text{ m}) \times 134 \times 10^{-6} \text{ kg/s}\cdot\text{m}} = 19,004.$$

Continued ...

### PROBLEM 8.73 (Cont.)

Hence, the flow is turbulent. With the assumption of fully developed conditions, it follows from Eq. 8.60 that

$$h_i = \frac{k_w}{D} \times 0.023 \text{Re}_D^{4/5} \text{Pr}_w^{0.3}. \quad (3)$$

For the *external air flow*

$$\text{Re}_D = \frac{V(D+2t)}{\nu} = \frac{4 \text{ m/s}(1.3\text{m})}{12.6 \times 10^{-6} \text{ m}^2/\text{s}} = 4.13 \times 10^5.$$

Using Eq. 7.53 to obtain the outside convection coefficient,

$$h_o = \frac{k_a}{(D+2t)} \times 0.076 \text{Re}_D^{0.7} \text{Pr}_a^{0.37} (\text{Pr}_a / \text{Pr}_s)^{1/4}. \quad (4)$$

(b) The heat transfer per unit length of pipe at the inlet is

$$q' = \pi D U_i (T_{m,i} - T_\infty). \quad (5)$$

From Eqs. (3 and 4),

$$h_i = \frac{0.665 \text{ W/m} \cdot \text{K}}{1 \text{ m}} \times 0.023 (19,004)^{4/5} (0.91)^{0.3} = 39.4 \text{ W/m}^2 \cdot \text{K}$$

$$h_o = \frac{0.023 \text{ W/m} \cdot \text{K}}{(1.3 \text{ m})} \times 0.076 (4.13 \times 10^5)^{0.7} (0.71)^{0.37} (1)^{1/4} = 10.1 \text{ W/m}^2 \cdot \text{K}.$$

Hence, from Eq. (2)

$$U_i = \left[ \frac{1}{39.4 \text{ W/m}^2 \cdot \text{K}} + \frac{1 \text{ m}}{0.1 \text{ W/m} \cdot \text{K}} \ln\left(\frac{1.3}{1}\right) + \frac{1}{1.3} \times \frac{1}{10.1 \text{ W/m}^2 \cdot \text{K}} \right]^{-1} = 0.37 \text{ W/m}^2 \cdot \text{K}$$

and from Eq. (5)

$$q' = \pi (1 \text{ m}) (0.37 \text{ W/m}^2 \cdot \text{K}) (200 + 10)^\circ \text{C} = 244 \text{ W/m}. \quad <$$

Since  $U_i$  is a constant, independent of  $x$ , Eq. (1) may be integrated from  $x = 0$  to  $x = L$ . The result is Eq. 8.45a.

$$\frac{T_\infty - T_{m,o}}{T_\infty - T_{m,i}} = \exp\left(-\frac{\pi DL}{\dot{m} c_{p,w}} U_i\right) = \exp\left(-\frac{\pi \times 1 \text{ m} \times 500 \text{ m}}{2 \text{ kg/s} \times 4500 \text{ J/kg} \cdot \text{K}} \times 0.37 \text{ W/m}^2 \cdot \text{K}\right)$$

Hence 
$$\frac{T_\infty - T_{m,o}}{T_\infty - T_{m,i}} = 0.937.$$

$$T_{m,o} = T_\infty + 0.937(T_{m,i} - T_\infty) = 187^\circ \text{C}. \quad <$$

**COMMENTS:** The largest contribution to the denominator on the right-hand side of Eq. (2) is made by the conduction term (the insulation provides 96% of the total resistance to heat transfer). For this reason the assumption of fully developed conditions throughout the pipe has a negligible effect on the calculations. Since the reduction in  $T_m$  is small ( $13^\circ\text{C}$ ), little error is incurred by evaluating all properties of water at  $T_{m,i}$ .

## PROBLEM 8.74

**KNOWN:** Inner and outer radii and thermal conductivity of a Teflon tube. Flowrate and temperature of confined water. Heat flux at outer surface and temperature and convection coefficient of ambient air.

**FIND:** Fraction of heat transfer to water and temperature of tube outer surface.

**SCHEMATIC:**

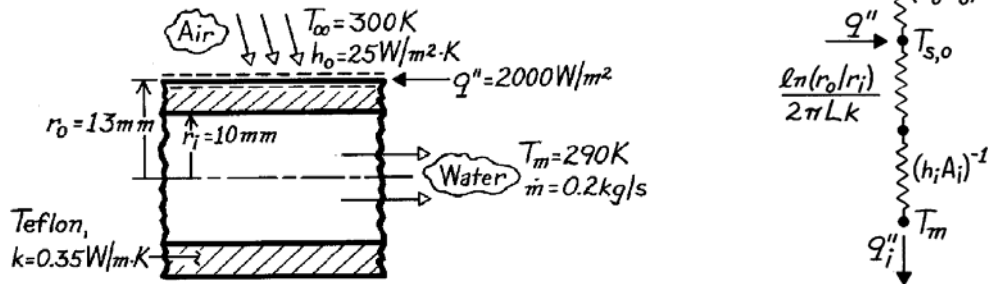

**ASSUMPTIONS:** (1) Steady-state conditions, (2) Fully-developed flow, (3) One-dimensional conduction, (4) Negligible tape contact and conduction resistances.

**PROPERTIES:** Table A-6, Water ( $T_m = 290\text{K}$ ):  $\mu = 1080 \times 10^{-6} \text{ kg/s}\cdot\text{m}$ ,  $k = 0.598 \text{ W/m}\cdot\text{K}$ ,  $\text{Pr} = 7.56$ .

**ANALYSIS:** The outer surface temperature follows from a surface energy balance

$$(2\pi r_o L)q'' = \frac{T_{s,o} - T_\infty}{(h_o 2\pi r_o L)^{-1}} + \frac{T_{s,o} - T_m}{\left(\ln(r_o/r_i)/2\pi Lk\right) + (1/2\pi r_i L h_i)}$$

$$q'' = h_o (T_{s,o} - T_\infty) + \frac{T_{s,o} - T_m}{(r_o/k)\ln(r_o/r_i) + (r_o/r_i)/h_i}$$

With  $\text{Re}_D = 4 \dot{m}/(\pi D\mu) = 4(0.2\text{kg/s})/[\pi(0.02\text{ m})1080 \times 10^{-6} \text{ kg/s}\cdot\text{m}] = 11,789$

the flow is turbulent and Eq. 8.60 yields

$$h_i = (k/D_i)0.023\text{Re}_D^{4/5}\text{Pr}^{0.4} = (0.598 \text{ W/m}\cdot\text{K}/0.02 \text{ m})(0.023)(11,789)^{4/5}(7.56)^{0.4} = 2792 \text{ W/m}^2\cdot\text{K}.$$

Hence

$$2000 \text{ W/m}^2 = 25 \text{ W/m}^2\cdot\text{K}(T_{s,o} - 300\text{K}) + \frac{T_{s,o} - 290 \text{ K}}{(0.013 \text{ m}/0.35 \text{ W/m}\cdot\text{K})\ln(1.3) + (1.3)/(2792 \text{ W/m}^2\cdot\text{K})}$$

and solving for  $T_{s,o}$ ,  $T_{s,o} = 308.3 \text{ K}$ . <

The heat flux to the air is

$$q''_o = h_o (T_{s,o} - T_\infty) = 25 \text{ W/m}^2\cdot\text{K}(308.3 - 300) \text{ K} = 207.5 \text{ W/m}^2.$$

Hence,  $q''_i/q'' = (2000 - 207.5) \text{ W/m}^2/2000 \text{ W/m}^2 = 0.90$ . <

**COMMENTS:** The resistance to heat transfer by convection to the air substantially exceeds that due to conduction in the teflon and convection in the water. Hence, most of the heat is transferred to the water.

## PROBLEM 8.75

**KNOWN:** Temperature recorded by a thermocouple inserted in a stack containing flue gases with a prescribed flow rate. Diameters and emissivities of thermocouple tube and gas stack. Conditions associated with stack surroundings.

**FIND:** Equations for predicting thermocouple error and error associated with prescribed conditions.

**SCHEMATIC:**

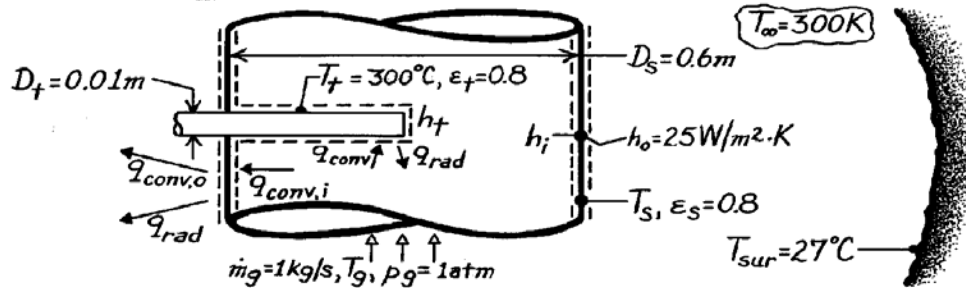

**ASSUMPTIONS:** (1) Steady-state conditions, (2) Flue gas has properties of air at  $T_g \approx 327^\circ\text{C}$ , (3) Stack forms a large enclosure about the thermocouple tube and surroundings form a large enclosure around the stack, (4) Stack surface energy balance is unaffected by heat loss to tube, (5) Gas flow is fully developed, (6) Negligible conduction along thermocouple tube, (7) Stack wall is thin.

**PROPERTIES:** Table A-4, Air ( $T_g \approx 600\text{K}$ ,  $p_g = 1\text{ atm}$ ):  $\rho = 0.58\text{ kg/m}^3$ ,  $\mu = 305.8 \times 10^{-7}\text{ N}\cdot\text{s/m}^2$ ,  $\nu = 52.7 \times 10^{-6}\text{ m}^2/\text{s}$ ,  $k = 0.0469\text{ W/m}\cdot\text{K}$ ,  $\text{Pr} = 0.685$ .

**ANALYSIS:** Determination of the thermocouple error necessitates determining the gas temperature  $T_g$  and relating it to the thermocouple temperature  $T_t$ . From an energy balance applied to a control surface about the thermocouple,

$$q_{\text{conv}} = q_{\text{rad}} \quad \text{or} \quad h_t A_t (T_g - T_t) = \varepsilon_t \sigma A_t (T_t^4 - T_s^4).$$

$$\text{Hence} \quad T_g = T_t + \frac{\varepsilon_t \sigma}{h_t} (T_t^4 - T_s^4). \quad (1) <$$

However,  $T_s$  is unknown and must be determined from an energy balance on the stack wall.

$$q_{\text{conv},i} = q_{\text{conv},o} + q_{\text{rad}}$$

$$h_i A_s (T_g - T_s) = h_o A_s (T_s - T_\infty) + \varepsilon_s \sigma A_s (T_s^4 - T_{\text{sur}}^4)$$

$$\text{or} \quad T_g = T_s + \frac{h_o}{h_i} (T_s - T_\infty) + \frac{\varepsilon_s \sigma}{h_i} (T_s^4 - T_{\text{sur}}^4). \quad (2) <$$

$T_g$  and  $T_s$  may be determined by simultaneously solving Eqs. (1) and (2). For the prescribed conditions

$$\text{Re}_{D_t} = \frac{\rho V D_t}{\mu} = \frac{\rho (\dot{m}_g / \rho \pi D_s^2 / 4) D_t}{\mu} = \frac{4 \dot{m}_g D_t}{\pi \mu D_s^2} = \frac{4 \times 1\text{ kg/s} \times 0.01\text{ m}}{\pi \times 305.8 \times 10^{-7}\text{ N}\cdot\text{s/m}^2 (0.6\text{ m})^2} = 1157.$$

Continued ...

**PROBLEM 8.75 (Cont.)**

Assuming  $(Pr/Pr_s) = 1$ , it follows from the Zukauskus correlation

$$\overline{Nu}_D = 0.26 Re_{Dt}^{0.6} Pr^{0.37}$$

where  $C = 0.26$  and  $m = 0.6$  from Table 7.4. Hence

$$h_t = \frac{0.0469 \text{ W/m} \cdot \text{K}}{0.01 \text{ m}} (1157)^{0.6} (0.685)^{0.37} \times 0.26 = 73 \text{ W/m}^2 \cdot \text{K}.$$

Hence, from Eq. (1) 
$$T_g = 573 \text{ K} + \frac{0.8 \times 5.67 \times 10^{-8} \text{ W/m}^2 \cdot \text{K}^4}{73 \text{ W/m}^2 \cdot \text{K}} (573^4 - T_s^4) \text{ K}^4$$

$$T_g = 573 \text{ K} + 67 \text{ K} - 6.214 \times 10^{-10} T_s^4 = 640 - 6.214 \times 10^{-10} T_s^4. \quad (1a)$$

Also, 
$$Re_{Ds} = \frac{4 \dot{m}_g}{\pi D_s \mu} = \frac{4 \times 1 \text{ kg/s}}{\pi (0.6 \text{ m}) 305.8 \times 10^{-7} \text{ N} \cdot \text{s/m}^2} = 6.94 \times 10^4$$

and the gas flow is turbulent. Hence from the Dittus-Boelter correlation,

$$h_i = \frac{k}{D_s} 0.023 Re_{Ds}^{4/5} Pr^{0.3} = \frac{0.0469 \text{ W/m} \cdot \text{K}}{0.6 \text{ m}} \times 0.023 (6.94 \times 10^4)^{4/5} \times (0.685)^{0.3} = 12 \text{ W/m}^2 \cdot \text{K}.$$

Hence from Eq. (2)

$$T_g = T_s + \frac{25}{12} (T_s - 300 \text{ K}) + \frac{0.8 \times 5.67 \times 10^{-8} \text{ W/m}^2 \cdot \text{K}^4}{12 \text{ W/m}^2 \cdot \text{K}} [T_s^4 - 300^4] \text{ K}^4$$

$$T_g = T_s + 2.083 T_s - 625 \text{ K} + 3.78 \times 10^{-9} T_s^4 - 30.6 \text{ K} = -655.6 \text{ K} + 3.083 T_s + 3.78 \times 10^{-9} T_s^4. \quad (2a)$$

Solve Eqs. (1a) and (2a) by trial-and-error. Assume values for  $T_s$  and determine  $T_g$  from (1a) and (2a). Continue until values of  $T_g$  agree.

$T_s$ (K)	$T_g$ (K) $\rightarrow$ (1a)	$T_g$ (K) $\rightarrow$ (2a)
400	624	674
375	628	575
387	626	622
388	626	626

Hence  $T_s = 388 \text{ K}$ ,  $T_g = 626 \text{ K}$

and the thermocouple error is  $T_g - T_t = 626 \text{ K} - 573 \text{ K} = 53^\circ\text{C}$ . <

**COMMENTS:** The thermocouple error results from radiation exchange between the thermocouple tube and the cooler stack wall. Anything done to  $\uparrow T_s$  would  $\downarrow$  this error (e.g.,  $\downarrow h_o$  or  $\uparrow T_\infty$  and  $T_{sur}$ ). The error also  $\downarrow$  with  $\uparrow h_t$ . The error could be reduced by installing a radiation shield around the tube.



## PROBLEM 8.76

**KNOWN:** Platen heated by hot ethylene glycol flowing through tubing arrangement with spacing  $S$  soldered to lower surface. Top surface exposed to convection process.

**FIND:** Tube spacing  $S$  and heating fluid temperature  $T_m$  which will maintain the top surface at  $45 \pm 0.25^\circ\text{C}$ .

**SCHEMATIC:**

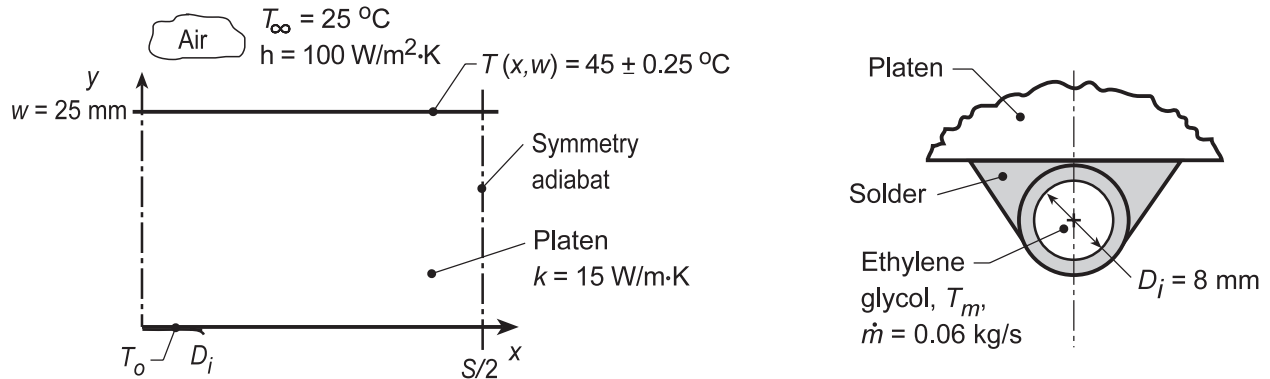

**ASSUMPTIONS:** (1) Steady-state conditions; (2) Lower surface is insulated, all heat transfer from hot fluid is into platen; (3) Copper tube is thick-walled such that interface between solder and platen is isothermal; (4) Fully developed flow conditions in tube.

**PROPERTIES:** Table A.4, Ethylene glycol ( $T_m = 60^\circ\text{C}$ ):  $\mu = 0.00522 \text{ N}\cdot\text{s}/\text{m}^2$ ,  $k = 0.2603 \text{ W}/\text{m}\cdot\text{K}$ .

**ANALYSIS:** Begin the analysis by setting up a nodal mesh ( $9 \times 6$ ) to represent the platen experiencing convection on the top surface ( $T_\infty$ ,  $h$ ) while the two side boundaries are symmetry adiabats. On the lower surface, nodes 46 and 47 represent the isothermal platen-solder interface maintained at  $T_0$  by the hot fluid. The remaining nodes (49-54) are insulated on their lower boundary.

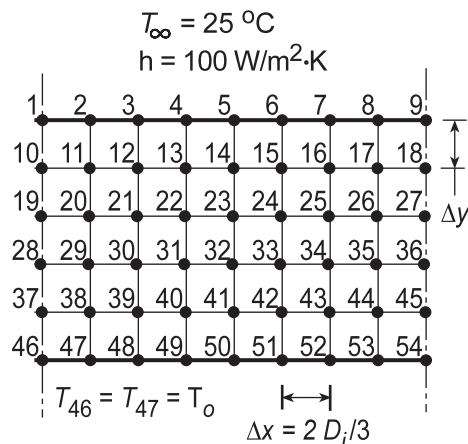

The heat rate supplied by the tube to the platen can be expressed as

$$q'_{cv} = 0.5h_o(\pi D_i)(T_m - T_0) \quad (1)$$

From energy balances about nodes 46 and 47, the heat rate into the platen by conduction can be expressed as

$$q'_{cd} = q'_a + q'_b + q'_c \quad (2)$$

$$q'_a = k(\Delta x/2)(T_{46} - T_{37})/\Delta y \quad (3)$$

Continued...

**PROBLEM 8.76 (Cont.)**

$$q'_b = k(\Delta x)(T_{47} - T_{38})/\Delta y \quad (4)$$

$$q'_c = k(\Delta y/2)(T_{47} - T_{48})/\Delta x \quad (5)$$

and we require that

$$q'_{cd} = q'_{cv} \quad (6)$$

The convection coefficient for internal flow can be estimated from a correlation assuming fully developed flow. First, characterize the flow with

$$Re_D = \frac{4\dot{m}}{\pi D_i \mu} = \frac{4 \times 0.06 \text{ kg/s}}{\pi (0.008 \text{ m}) 0.00522 \text{ N}\cdot\text{s/m}^2} = 1829$$

and since it is laminar,

$$Nu_D = \frac{h_o D_i}{k} = 3.66$$

$$h_o = 3.66 \times 0.2603 \text{ W/m}\cdot\text{K} / 0.008 \text{ m} = 119.1 \text{ W/m}\cdot\text{K}$$

where properties are evaluated at  $T_m$ . Using the *IHT Finite-Difference Tool for Two-Dimensional Steady-State Conditions* and the *Properties Tool for Ethylene Glycol*, along with the foregoing rate equations and energy balances, Eqs. (1-6), a model was developed to solve for the temperature distribution in the platen. In the solution, we determined what hot fluid temperature was required to maintain  $T_1 = 45^\circ\text{C}$ . Two trials were run. In the first, the nodal arrangement was as shown above ( $9 \times 6$ ) for which  $S/2 = (9 - 1)\Delta x = 42.67 \text{ mm}$  with  $\Delta x = 2D_i/3 = 5.33 \text{ mm}$  and  $\Delta y = w/5 = 5 \text{ mm}$ . In the second trial, we repositioned the right-hand symmetry adiabat to pass vertically through the nodes 6-51 so that now the nodal mesh is ( $6 \times 6$ ) and  $S/2 = (6 - 1)\Delta x = 26.65 \text{ mm}$  with  $\Delta x$  and  $\Delta y$  remaining the same. The results of the trials are tabulated below.

Trial	Mesh	$T_1$ ( $^\circ\text{C}$ )	$T_6$ ( $^\circ\text{C}$ )	$T_9$ ( $^\circ\text{C}$ )	$T_m$ ( $^\circ\text{C}$ )	$q'_{cv}$ (W/m)
1	$9 \times 6$	45.0	43.5	43.0	105	80.5
2	$6 \times 6$	45.0	44.5	---	85	52.6

From the trial 2 results, the surface temperature uniformity is  $(T_1 - T_6) = 0.5^\circ\text{C}$  which satisfies the  $\pm 0.25^\circ\text{C}$  requirement. So that suitable tube spacing and fluid temperature are

$$S = 53 \text{ mm}$$

$$T_m = 85^\circ\text{C}$$

<

**COMMENTS:** (1) Recognize that the grid spacing is quite coarse and good practice demands that we repeat the analysis decreasing the nodal spacing until no further changes are seen in  $T_m$ .

(2) In the first trial, note that  $T_m = 105^\circ\text{C}$  which of course, is not possible.

## PROBLEM 8.77

**KNOWN:** Features of tubing used in a ground source heat pump. Temperature of surrounding soil. Fluid inlet temperature and flowrate.

**FIND:** (a) Effect of tube length on outlet temperature, (b) Recommended tube length and the effect of variations in the flowrate.

**SCHEMATIC:**

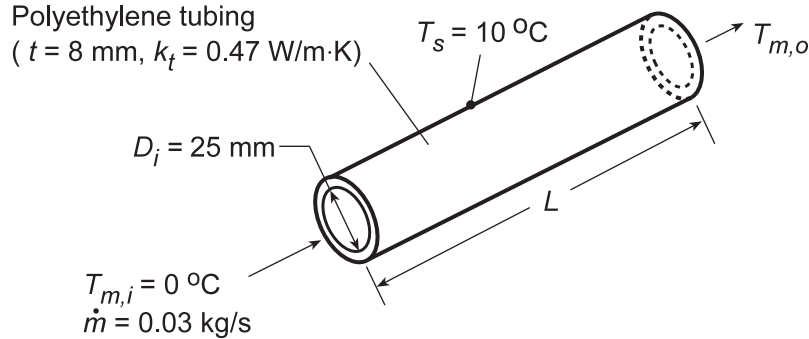

**ASSUMPTIONS:** (1) Steady-state conditions, (2) Constant properties, (3) Negligible conduction resistance in soil, (4) Incompressible liquid with negligible viscous dissipation, (5) Fluid properties correspond to those of water.

**PROPERTIES:** Table A.6 (assume  $\bar{T}_m = 277 \text{ K}$ ):  $c_p = 4206 \text{ J/kg}\cdot\text{K}$ ,  $\mu = 1560 \times 10^{-6} \text{ N}\cdot\text{s/m}^2$ ,  $k = 0.577 \text{ W/m}\cdot\text{K}$ ,  $\text{Pr} = 11.44$ .

**ANALYSIS:** (a) For the prescribed conditions,  $\text{Re}_D = 4\dot{m}/\pi D_i \mu = 4(0.03 \text{ kg/s})/\pi(0.025 \text{ m})1560 \times 10^{-6} \text{ N}\cdot\text{s/m}^2 = 980$  and the flow is laminar. With  $\text{Pr} > 5$ , Eq. 8.57 may be used to determine the average convection coefficient, with Eq. 8.56 defining the Graetz number:

$$\overline{\text{Nu}}_D = 3.66 + \frac{0.0668(D/L)\text{Re}_D \text{Pr}}{1 + 0.04[(D/L)\text{Re}_D \text{Pr}]^{2/3}}$$

With  $T_s$  used in lieu of  $T_\infty$ , Eq. 8.45b may be used to determine  $T_{m,o}$ ,

$$\frac{T_s - T_{m,o}}{T_s - T_{m,i}} = \exp\left(-\frac{L}{\dot{m}c_p R'_{\text{tot}}}\right)$$

where  $R'_{\text{tot}}$  accounts for the convection and tube wall conduction resistances,

$$R'_{\text{tot}} = R'_{\text{cnv}} + R'_{\text{cnd}} = \left(1/\pi D_i \bar{h}\right) + \ln(D_o/D_i)/2\pi k_t$$

and

$$D_o = D_i + 2t = 41 \text{ mm}.$$

Using the *Correlations and Properties* Toolpads of IHT, the following results were obtained for the effect of the tube length  $L$  on  $T_{m,o}$ .

Continued...

### PROBLEM 8.77 (Cont.)

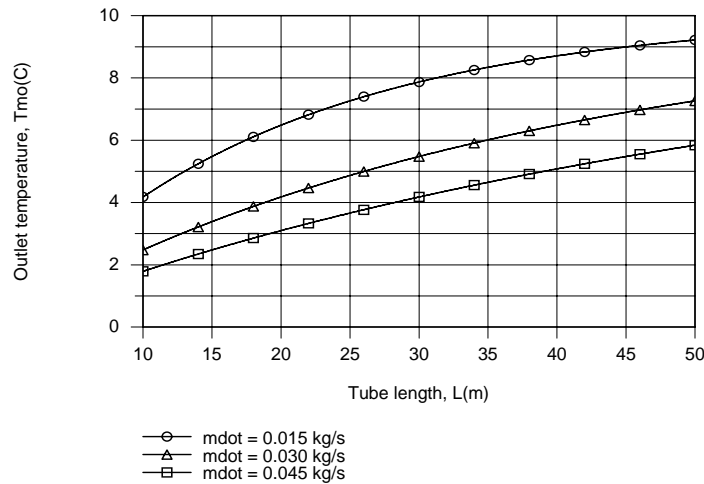

The longer the tube the larger the rate of heat extraction from the soil, and for  $\dot{m} = 0.030$  kg/s, the temperature rise of  $\Delta T = (T_{m,o} - T_{m,i}) \approx 7^\circ\text{C}$  is well below the maximum possible value of  $\Delta T_{\max} = 10^\circ\text{C}$ .

(b) The length should be *at least* 50 m long. If the flowrate were reduced by 50% ( $\dot{m} = 0.015$  kg/s), the corresponding temperature rise would be close to  $\Delta T_{\max}$  and  $L = 50$  m would be close to optimal. However, for the nominal flowrate and a 50% increase from the nominal, the length should exceed 50 m to recover more heat and provide a heat pump inlet temperature which is closer to the maximum possible value.

**COMMENTS:** In practice, the tube surface temperature would be less than  $10^\circ\text{C}$  (if the temperature of the soil well removed from the tube were at  $10^\circ\text{C}$ ), thereby reducing the heat extraction rate and  $T_{m,o}$ .

### PROBLEM 8.78

**KNOWN:** Effect of entry length on average Nusselt number for turbulent flow in a tube.

**FIND:** Ratio of average to fully developed Nusselt numbers for prescribed conditions.

**SCHEMATIC:**

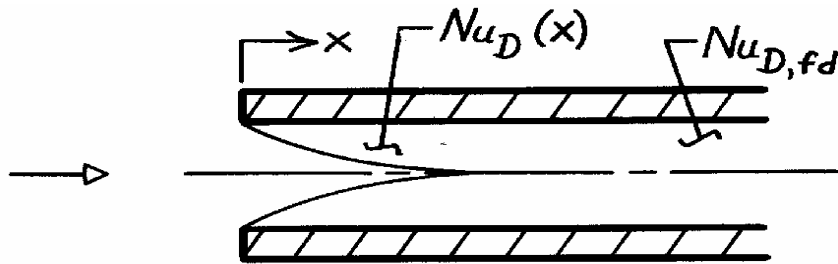

**ASSUMPTIONS:** (1) Sharp edged inlet, (2) Combined entry region.

**ANALYSIS:** From Eq. 8.63,

$$\frac{\overline{Nu}_D}{Nu_{D,fd}} = 1 + \frac{C}{(x/D)^m}$$

and with  $C = 24Re_D^{-0.23}$  and  $m = 0.815 - 2.08 \times 10^{-6} Re_D$ ,

$$\frac{\overline{Nu}_D}{Nu_{D,fd}} = 1 + \frac{24Re_D^{-0.23}}{(x/D)^{(0.815 - 2.08 \times 10^{-6} Re_D)}}$$

It follows that

$\left(\overline{Nu}_D / Nu_{D,fd}\right)$	$Re_D$	$x/D$
1.463	$10^4$	10
1.116	$10^4$	60
1.420	$10^5$	10
1.142	$10^5$	60

**COMMENTS:** The assumption  $\overline{Nu}_D \approx Nu_{fd}$  for  $x/D = 10$  would result in underprediction of  $\overline{Nu}_D$  by approximately 45%. The underprediction is only approximately 10% for  $x/D = 60$ .

### PROBLEM 8.79

**KNOWN:** Fluid enters a thin-walled tube of 5-mm diameter and 2-m length with a flow rate of 0.04 kg/s and temperature of  $T_{m,i} = 85^\circ\text{C}$ ; tube surface temperature is maintained at  $T_s = 25^\circ\text{C}$ ; and, for this *base* operating condition, the outlet temperature is  $T_{m,o} = 31.1^\circ\text{C}$ .

**FIND:** The outlet temperature if the flow rate is doubled?

**SCHEMATIC:**

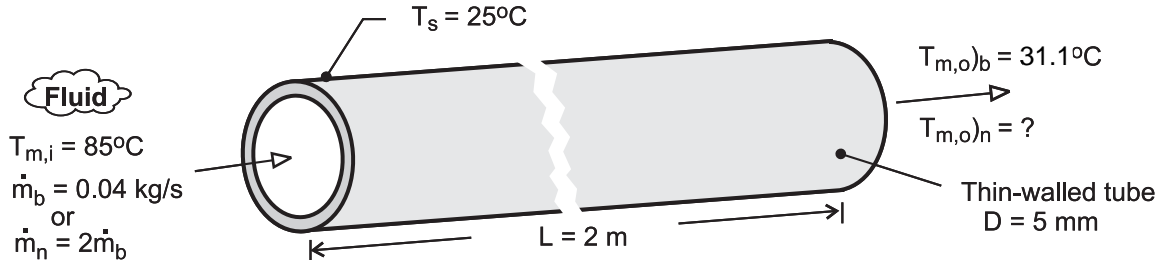

**ASSUMPTIONS:** (1) Flow is fully developed and turbulent, (2) Fluid properties are independent of temperature, (3) Constant surface temperature cooling conditions, (4) Applicability of Eq. 8.34.

**ANALYSIS:** For the *base* operating condition (b), the rate equation, Eq. 8.41b, with  $C = \dot{m}c_p$ , the capacity rate, is

$$\frac{T_s - T_{m,o})_b}{T_s - T_{m,i}} = \exp\left(-\frac{PL\bar{h}_b}{C_b}\right) \quad (1)$$

Substituting numerical values, with  $P = \pi D$ , find the ratio,  $\bar{h}_b / C_b$ ,

$$\frac{25 - 31.1}{25 - 85} = \exp\left[-\pi \times 0.005 \text{ m} \times 2 \text{ m} \left(\bar{h}_b / C_b\right)\right]$$

$$\bar{h}_b / C_b = 72.77 \text{ m}^{-2}$$

For the *new* operating condition (n), the flow rate is doubled,  $C_n = 2C_b$ , and the convection coefficient scales according to the Dittus-Boelter relation, Eq. 8.60,

$$\bar{h} \propto \text{Re}_D^{0.8} \propto \dot{m}^{0.8}$$

$$\bar{h}_n = 2^{0.8}\bar{h}_b \text{ and } (\bar{h}_n / C_n) = (2^{0.8} / 2)(\bar{h}_b / C_b) \quad (2)$$

Using the rate equation for the new operating condition, find

$$\frac{T_s - T_{m,o})_n}{T_s - T_{m,i}} = \exp\left(-\frac{PL\bar{h}_n}{C_n}\right) = \exp\left[-PL \times 0.871(\bar{h}_b / C_b)\right] \quad (3)$$

$$\frac{25 - T_{m,o})_n}{25 - 85} = \exp\left[-\pi \times 0.005 \text{ m} \times 2 \text{ m} \times 0.871 \times 72.77 \text{ m}^{-2}\right]$$

$$T_{m,o})_n = 33.2^\circ\text{C} \quad <$$

### PROBLEM 8.80

**KNOWN:** Flow rate and inlet temperature of air passing through a rectangular duct of prescribed dimensions and surface heat flux.

**FIND:** Air and duct surface temperatures at outlet.

**SCHEMATIC:**

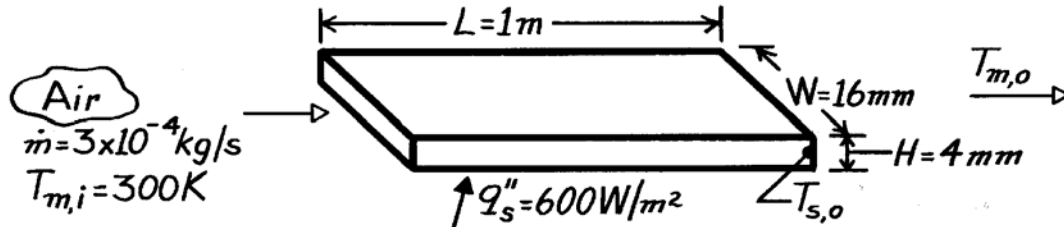

**ASSUMPTIONS:** (1) Steady-state conditions, (2) Uniform surface heat flux, (3) Constant properties, (4) Atmospheric pressure, (5) Fully developed conditions at duct exit, (6) Ideal gas with negligible viscous dissipation and pressure variation.

**PROPERTIES:** Table A-4, Air ( $\bar{T}_m \approx 300\text{K}$ , 1 atm):  $c_p = 1007\text{ J/kg}\cdot\text{K}$ ,  $\mu = 184.6 \times 10^{-7}\text{ N}\cdot\text{s/m}^2$ ,  $k = 0.0263\text{ W/m}\cdot\text{K}$ ,  $Pr = 0.707$ .

**ANALYSIS:** For this uniform heat flux condition, the heat rate is

$$q = q_s'' A_s = q_s'' [2(L \times W) + 2(L \times H)]$$

$$q = 600\text{ W/m}^2 [2(1\text{m} \times 0.016\text{m}) + 2(1\text{m} \times 0.004\text{m})] = 24\text{ W}.$$

From an overall energy balance

$$T_{m,o} = T_{m,i} + \frac{q}{\dot{m} c_p} = 300\text{K} + \frac{24\text{ W}}{3 \times 10^{-4}\text{ kg/s} \times 1007\text{ J/kg}\cdot\text{K}} = 379\text{ K} \quad <$$

The surface temperature at the outlet may be determined from Newton's law of cooling, where

$$T_{s,o} = T_{m,o} + q''/h.$$

From Eqs. 8.66 and 8.1

$$D_h = \frac{4 A_c}{P} = \frac{4(0.016\text{m} \times 0.004\text{m})}{2(0.016\text{m} + 0.004\text{m})} = 0.0064\text{ m}$$

$$Re_D = \frac{\rho u_m D_h}{\mu} = \frac{\dot{m} D_h}{A_c \mu} = \frac{3 \times 10^{-4}\text{ kg/s}(0.0064\text{m})}{64 \times 10^{-6}\text{ m}^2 (184.6 \times 10^{-7}\text{ N}\cdot\text{s/m}^2)} = 1625.$$

Hence the flow is laminar, and from Table 8.1

$$h = \frac{k}{D_h} 5.33 = \frac{0.0263\text{ W/m}\cdot\text{K}}{0.0064\text{ m}} 5.33 = 22\text{ W/m}^2 \cdot \text{K}$$

$$T_{s,o} = 379\text{ K} + \frac{600\text{ W/m}^2}{22\text{ W/m}^2 \cdot \text{K}} = 406\text{ K} \quad <$$

**COMMENTS:** The calculations should be repeated with properties evaluated at  $\bar{T}_m = 340\text{ K}$ . The change in  $T_{m,o}$  would be negligible, and  $T_{s,o}$  would decrease slightly.

## PROBLEM 8.81

**KNOWN:** Inlet temperature and mass flow rate of air flow. Geometry and dimensions of channels through a mold. Mold temperature.

**FIND:** (a) Heat transferred to the air for case A, (b) Heat transferred to the air for case B, and (c) pressure drop for both cases.

**SCHEMATIC:**

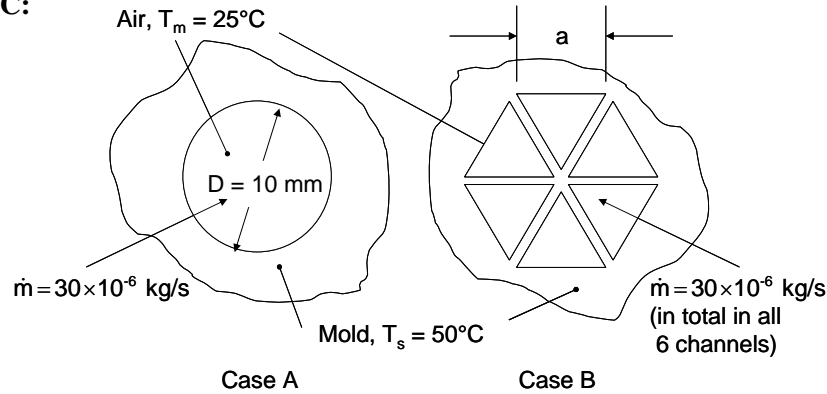

**ASSUMPTIONS:** (1) Flow is hydrodynamically and thermally fully developed, (2) Mold temperature is uniform. (3) Narrow fins between channels in case B are at the mold temperature.

**PROPERTIES:** Table A-4, Air ( $T \approx 310$  K assumed, 1 atm):  $\rho = 1.128$  kg/m<sup>3</sup>,  $c_p = 1007$  J/kg·K,  $\mu = 189.3 \times 10^{-7}$  N·s/m<sup>2</sup>,  $k = 0.027$  W/m·K.

**ANALYSIS:**

(a) The Reynolds number is

$$Re_D = \frac{4 \dot{m}}{\pi D \mu} = \frac{4 \times 30 \times 10^{-6} \text{ kg/s}}{\pi \times 0.01 \text{ m} \times 189.3 \times 10^{-7} \text{ N} \cdot \text{s/m}^2} = 202$$

Thus, the flow is laminar. Since it has also been assumed that the flow is fully developed and the mold temperature is uniform, the Nusselt number is

$$Nu_D = 3.66$$

Thus  $h = Nu_D k / D = 3.66 \times 0.027 \text{ W/m} \cdot \text{K} / 0.01 \text{ m} = 9.88 \text{ W/m}^2 \cdot \text{K}$ .

The outlet temperature can be found from Equation 8.41b,

$$\begin{aligned} T_{m,o} &= T_s + (T_{m,i} - T_s) \exp\left(-\frac{P L}{\dot{m} c_p} h\right) \\ &= 50^\circ\text{C} + (25^\circ\text{C} - 50^\circ\text{C}) \exp\left(-\frac{\pi \times 0.01 \text{ m} \times 0.1 \text{ m} \times 9.88 \text{ W/m}^2 \cdot \text{K}}{30 \times 10^{-6} \text{ kg/s} \times 1007 \text{ J/kg} \cdot \text{K}}\right) \\ &= 41.0^\circ\text{C} \end{aligned}$$

Thus

$$q = \dot{m} c_p (T_{m,o} - T_{m,i}) = 30 \times 10^{-6} \text{ kg/s} \times 1007 \text{ J/kg} \cdot \text{K} \times (41.0^\circ\text{C} - 25^\circ\text{C}) = 0.485 \text{ W} \quad \leftarrow$$

(b) We first determine the dimensions of the triangular channels from the requirement that the total area is the same as case A.

Continued...



**PROBLEM 8.81 (Cont.)**

$$\pi D^2/4 = 6a^2/2$$

$$a = \left(\frac{\pi}{12}\right)^{1/2} D = \left(\frac{\pi}{12}\right)^{1/2} \times 10 \text{ mm} = 5.1 \text{ mm}$$

and the flowrate in one channel is  $5 \times 10^{-6}$  kg/s.

The hydraulic diameter is  $D_h = 4A_c/P = 4(a^2/2)/3a = 2a/3 = 3.4\text{mm}$ .

The Reynolds number is

$$\text{Re}_D = \frac{4 \dot{m}}{\pi D_h \mu} = \frac{4 \times 5 \times 10^{-6} \text{ kg/s}}{\pi \times 0.0034 \text{ m} \times 189.3 \times 10^{-7} \text{ N}\cdot\text{s/m}^2} = 98.6$$

so the flow is laminar. From Table 8.1, the Nusselt number is  $\text{Nu}_D = 2.47$ , so

$$h = \text{Nu}_D k / D_h = 2.47 \times 0.027 \text{ W/m}\cdot\text{K} / 0.0034 \text{ m} = 19.6 \text{ W/m}^2\cdot\text{K}.$$

The outlet temperature is

$$\begin{aligned} T_{m,o} &= T_s + (T_{m,i} - T_s) \exp\left(-\frac{P L}{\dot{m} c_p} \bar{h}\right) \\ &= 50^\circ\text{C} + (25^\circ\text{C} - 50^\circ\text{C}) \exp\left(-\frac{3 \times 0.0051 \text{ m} \times 0.1 \text{ m} \times 19.0 \text{ W/m}^2 \cdot \text{K}}{5 \times 10^{-6} \text{ kg/s} \times 1007 \text{ J/kg}\cdot\text{K}}\right) \\ &= 49.9^\circ\text{C} \end{aligned}$$

Then using the total flowrate to account for all six channels,

$$\dot{q} = \dot{m} c_p (T_{m,o} - T_{m,i}) = 30 \times 10^{-6} \text{ kg/s} \times 1007 \text{ J/kg}\cdot\text{K} \times (49.9^\circ\text{C} - 25^\circ\text{C}) = 0.753 \text{ W} \quad <$$

(c) The friction factor for case A is  $f = 64/\text{Re}_D = 64/202 = 0.317$ . The pressure drop is, from Equation 8.22a,

$$\Delta p = f \frac{\rho u_m^2}{2D} L$$

with  $u_m = \dot{m} / \rho A_c = 30 \times 10^{-6} \text{ kg/s} / (1.128 \text{ kg/m}^3 \times \pi (0.01 \text{ m})^2 / 4) = 0.339 \text{ m/s}$ . Thus

$$\Delta p = 0.317 \times \frac{1.128 \text{ kg/m}^3 \times (0.339 \text{ m/s})^2}{2 \times 0.01 \text{ m}} \times 0.1 \text{ m} = 0.205 \text{ Pa} \quad <$$

For Case B, from Table 8.1,  $f = 53/\text{Re}_D = 53/98.6 = 0.538$ , and  $u_m = 0.339 \text{ m/s}$  as in Case A. Thus

$$\Delta p = f \frac{\rho u_m^2}{2D_h} L = 0.538 \times \frac{1.128 \text{ kg/m}^3 \times (0.339 \text{ m/s})^2}{2 \times 0.0034 \text{ m}} \times 0.1 \text{ m} = 1.02 \text{ Pa} \quad <$$

COMMENTS: (1) Segmenting the channel into six smaller sections increases the heat transfer by 55%, but at the expense of almost a five-fold increase in the pressure drop. (2) For the circular duct, the hydrodynamic entry length, is  $x_{fd,h} = 0.05 \text{ Re}_D D = 0.1 \text{ m}$ , so it is not fully developed as assumed. For the triangular duct,  $x_{fd,h} = 0.05 \text{ Re}_D D_h = 0.02 \text{ m}$ , so the assumption is more appropriate. The thermal development length is shorter, since  $\text{Pr} = 0.7$ .

## PROBLEM 8.82

**KNOWN:** Dimensions, surface temperature and thermal conductivity of a *cold plate*. Velocity, inlet temperature, and properties of coolant.

**FIND:** (a) Model for determining the heat rate  $q$  and outlet temperature,  $T_{m,o}$ . (b) Values of  $q$  and  $T_{m,o}$  for prescribed conditions.

**SCHEMATIC:**

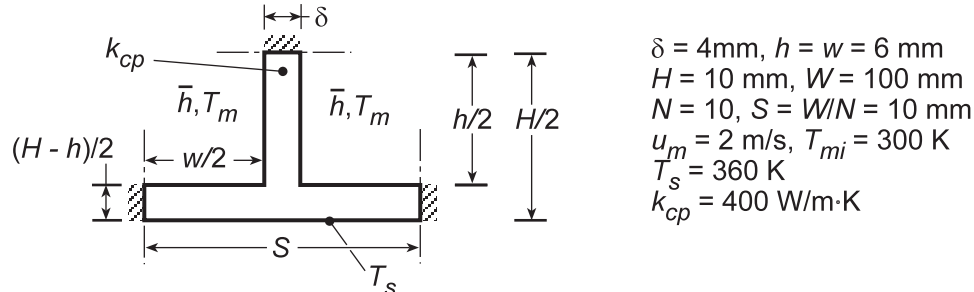

**ASSUMPTIONS:** (1) Steady-state conditions, (2) Incompressible liquid with negligible viscous dissipation, (3) Constant properties, (4) Symmetry about the midplane (horizontal) of the cold plate and the midplane (vertical) of each cooling channel, (5) Negligible heat transfer at sidewalls of cold plate, (6) One-dimensional conduction from outer surface of cold plate to base surface of channel and within the channel side walls, which act as extended surfaces.

**PROPERTIES:** Water (prescribed):  $\rho = 984 \text{ kg/m}^3$ ,  $c_p = 4184 \text{ J/kg}\cdot\text{K}$ ,  $\mu = 489 \times 10^{-6} \text{ N}\cdot\text{s/m}^2$ ,  $k = 0.65 \text{ W/m}\cdot\text{K}$ ,  $Pr = 3.15$ .

**ANALYSIS:** (a) The outlet temperature,  $T_{m,o}$ , may be determined from the energy balance prescribed by Eq. 8.45b,

$$\frac{T_s - T_{m,o}}{T_s - T_{m,i}} = \exp\left(-\frac{1}{\dot{m}_1 c_p R_{\text{tot}}}\right)$$

where  $\dot{m}_1 = \rho u_m A_c$  is the flowrate for a single channel and  $R_{\text{tot}}$  is the total resistance to heat transfer between the cold plate surface and the coolant for a particular channel. This resistance may be determined from the symmetrical section shown schematically, which represents one-half of the cell associated with a full channel. With the number of channels (and cells) corresponding to  $N = W/S$ , there are  $2N = 2(W/S)$  symmetrical sections, and the total resistance  $R_{\text{tot}}$  of a cell is one-half that of a symmetrical section. Hence,  $R_{\text{tot}} = R_{\text{ss}}/2$ , where the resistance of the symmetrical section includes the effect of conduction through the outer wall of the cold plate and convection from the inner surfaces. Hence,

$$R_{\text{ss}} = \frac{(H-h)/2}{k_{cp}(SW)} + \frac{1}{\eta_o \bar{h} A_t}$$

where  $A_t = A_f + A_b = 2(h/2 \times W) + (w \times W)$ ,  $\bar{h}$  is the average convection coefficient for the channel flow, and  $\eta_o$  is the overall surface efficiency.

$$\eta_o = 1 - \frac{A_f}{A_t} (1 - \eta_f)$$

Continued...

### PROBLEM 8.82 (Cont.)

The efficiency  $\eta_f$  corresponds to that of a straight, rectangular fin with an adiabatic tip, Eq. 3.92, and  $L_c = w/2$ . With  $D_h = 4A_c/P = 4w^2/4w = w = 0.006\text{ m}$ ,  $Re_{D_h} = \rho u_m D_h/\mu = 984\text{ kg/m}^3 \times 2\text{ m/s} \times 0.006\text{ m}/489 \times 10^{-6}\text{ N}\cdot\text{s/m}^2 = 24,150$  and the channel flow is turbulent. Assuming fully-developed flow throughout the channel, the Dittus-Boelter correlation, Eq. 8.60, may therefore be used to evaluate  $\bar{h}$ , where

$$\overline{Nu}_D \approx Nu_{D,fd} = 0.023 Re_D^{4/5} Pr^{0.4}$$

The total heat rate for the cold plate may be expressed as

$$q = Nq_1 = N\dot{m}_1 c_p (T_{m,o} - T_{m,i})$$

(b) For the prescribed conditions,

$$\dot{m}_1 = \rho u_m A_c = 984\text{ kg/m}^3 (2\text{ m/s})(0.006\text{ m})^2 = 0.0708\text{ kg/s}$$

$$\overline{Nu}_D = 0.023(24,150)^{4/5} (3.15)^{0.4} = 116.8$$

$$\bar{h} = 116.8\text{ k/D}_h = 116.8(0.65\text{ W/m}\cdot\text{K})/(0.006\text{ m}) = 12,650\text{ W/m}^2\cdot\text{K}$$

$$A_f = 2(h/2 \times W) = 2(0.003\text{ m} \times 0.1\text{ m}) = 6 \times 10^{-4}\text{ m}^2$$

$$A_t = A_f + A_b = 6 \times 10^{-4}\text{ m}^2 + (0.006\text{ m} \times 0.1\text{ m}) = 1.2 \times 10^{-3}\text{ m}^2$$

With  $m = (\bar{h}P_f/k_{cp}A_{cf})^{1/2} = [\bar{h}(2\delta + 2W)/k_{cp}(\delta W)]^{1/2} = [12,650\text{ W/m}^2\cdot\text{K}(0.008 + 0.200)\text{m}/400\text{ W/m}\cdot\text{K}(0.004 \times 0.100)\text{m}^2]^{1/2} = 128.2\text{ m}^{-1}$ .

$$\eta_f = \frac{\tanh m(h/2)}{m(h/2)} = \frac{\tanh(128.2 \times 0.003)}{128.2 \times 0.003} = \frac{0.366}{0.385} = 0.952$$

$$\eta_o = 1 - 0.5(1 - 0.952) = 0.976$$

$$R_{ss} = \frac{(0.010 - 0.006)\text{m}/2}{400\text{ W/m}\cdot\text{K}(0.01\text{ m} \times 0.1\text{ m})} + \frac{1}{0.976(12650\text{ W/m}^2\cdot\text{K})1.2 \times 10^{-3}\text{ m}^2}$$

$$R_{ss} = (0.005 + 0.0675)\text{ K/W} = 0.0725\text{ K/W}$$

With  $R_{\text{tot}} = R_{ss}/2 = 0.0362\text{ K/W}$ ,

$$\frac{T_s - T_{m,o}}{T_s - T_{m,i}} = \exp\left(-\frac{1}{0.0708\text{ kg/s} \times 4184\text{ J/kg}\cdot\text{K} \times 0.0362\text{ K/W}}\right) = 0.911$$

$$T_{m,o} = T_s - 0.911(T_s - T_{m,i}) = 360\text{ K} - 0.911(360 - 300)\text{ K} = 305.3\text{ K} \quad <$$

The total heat rate is

$$q = N\dot{m}_1 c_p (T_{m,o} - T_{m,i}) = 10 \times 0.0708\text{ kg/s} \times 4184\text{ J/kg}\cdot\text{K} (305.3 - 300)\text{ K} = 15,700\text{ W} \quad <$$

**COMMENTS:** The prescribed properties correspond to a value of  $\bar{T}_m$  which significantly exceeds that obtained from the foregoing solution ( $\bar{T}_m = 302.6\text{ K}$ ). Hence, the calculations should be repeated using more appropriate thermophysical properties (see next problem). From Eq. 3.90, the effectiveness of the extended surface is

$$\varepsilon = R_{t,b}/R_{t,f} = (\bar{h}\delta W)^{-1}/(\bar{h}A_f\eta_f)^{-1} = (A_f\eta_f/\delta W) = (6 \times 10^{-4}\text{ m}^2 \times 0.954)/(0.004\text{ m} \times 0.10\text{ m}) = 1.43.$$

Hence, the ribs are only marginally effective in enhancing heat transfer to the coolant.

### PROBLEM 8.83

**KNOWN:** Geometry, surface temperature and thermal conductivity of a *cold plate*. Velocity and inlet temperature of coolant.

**FIND:** Effect of channel width on total heat rate.

**SCHEMATIC:**

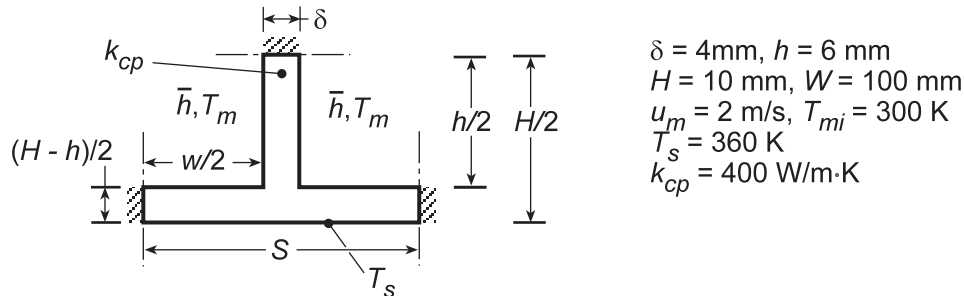

**ASSUMPTIONS:** (1) Steady-state conditions, (2) Incompressible liquid with negligible viscous dissipation, (3) Constant properties, (4) Symmetry about midplane (horizontal) of the cold plate and the midplane (vertical) of each channel, (5) Negligible heat transfer at sidewalls of cold plate, (6) One-dimensional conduction from outer surface of cold plate to base surface of channel and within the channel side walls, which act as extended surfaces.

**PROPERTIES:** Water: Evaluated at  $\bar{T}_m$  using the *Properties* Toolpad of IHT.

**ANALYSIS:** The model developed for the preceding problem was entered into the workspace of IHT, with the Dittus-Boelter equation and exponential relation accessed from the *Correlations* Toolpad and modified to account for the hydraulic diameter and the total resistance to heat transfer. Calculations were performed for

- |         |  |
|---------|--|
| Case 1: | $w = 96\text{ mm}, N = 1, S = W = 100\text{ mm}$ |
| Case 2: | $w = 46\text{ mm}, N = 2, S = 50\text{ mm}$      |
| Case 3: | $w = 21\text{ mm}, N = 4, S = 25\text{ mm}$      |
| Case 4: | $w = 6\text{ mm}, N = 10, S = 10\text{ mm}$      |
| Case 5: | $w = 1\text{ mm}, N = 20, S = 5\text{ mm}$       |

and the results are tabulated as follows.

Case	N	$D_h$ (m)	$Re_D$	$\bar{h}$ ( $\text{W}/\text{m}^2 \cdot \text{K}$ )	$T_{m,o}$ (K)	q (W)
1	1	0.01129	26,920	8783	302.1	10,090
2	2	0.01062	25,310	8892	302.3	10,370
3	4	0.00933	22,340	9142	302.6	10,960
4	10	0.00600	14,630	10,070	304.3	12,950
5	20	0.00171	4760	13,740	317.2	17,160

It is clearly beneficial to increase the number of channels, with the total heat rate increasing by approximately a factor of 5 as N increases from 1 to 20. The heat rate may be increased further by increasing  $u_m$ , and hence the flowrate per channel, although an upper limit would be associated with the pressure drop, which would increase with decreasing  $D_h$ . Could additional heat transfer enhancement be achieved by altering the thickness  $\delta$  of the channel walls?

**COMMENTS:** (1) Note that results obtained for Case 4 differ from those of the preceding problem due to different fluid properties. In this case the properties were evaluated at the actual value of  $\bar{T}_m = 302.2\text{ K}$ , rather than at an assumed (significantly larger) value. (2) Note that the Dittus-Boelter correlation is applied outside its intended range for the Reynolds number of case 5. The Gnielinski correlation would be preferable.

### PROBLEM 8.84

**KNOWN:** Temperature and velocity of gas flow between parallel plates of prescribed surface temperature and separation. Thickness and location of plate insert.

**FIND:** Heat flux to the plates (a) without and (b) with the insert.

**SCHEMATIC:**

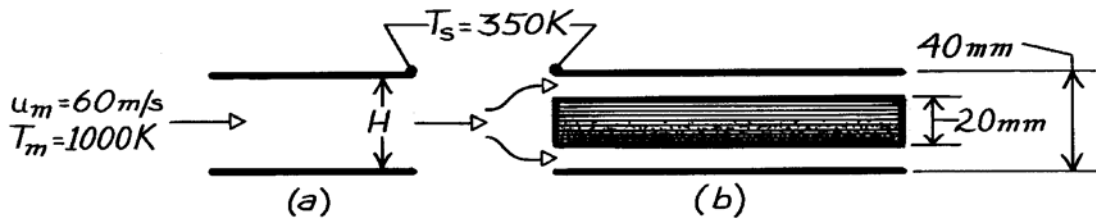

**ASSUMPTIONS:** (1) Steady-state conditions, (2) Negligible radiation, (3) Gas has properties of atmospheric air, (4) Plates are of infinite width  $W$ , (5) Fully developed flow.

**PROPERTIES:** Table A-4, Air (1 atm,  $T_m = 1000$  K):  $\rho = 0.348 \text{ kg/m}^3$ ,  $\mu = 424.4 \times 10^{-7} \text{ kg/s}\cdot\text{m}$ ,  $k = 0.0667 \text{ W/m}\cdot\text{K}$ ,  $\text{Pr} = 0.726$ .

**ANALYSIS:** (a) Based upon the hydraulic diameter  $D_h$ , the Reynolds number is

$$D_h = 4 A_c / P = 4(H \cdot W) / 2(H + W) = 2H = 80 \text{ mm}$$

$$\text{Re}_{D_h} = \frac{\rho u_m D_h}{\mu} = \frac{0.348 \text{ kg/m}^3 (60 \text{ m/s}) 0.08 \text{ m}}{424.4 \times 10^{-7} \text{ kg/s}\cdot\text{m}} = 39,360.$$

Since the flow is fully developed and turbulent, use the Dittus-Boelter correlation,

$$\text{Nu}_D = 0.023 \text{Re}_D^{4/5} \text{Pr}^{0.3} = 0.023(39,360)^{4/5} (0.726)^{0.3} = 99.1$$

$$h = \frac{k}{D_h} \text{Nu}_D = \frac{0.0667 \text{ W/m}\cdot\text{K}}{0.08 \text{ m}} 99.1 = 82.6 \text{ W/m}^2 \cdot \text{K}$$

$$q'' = h(T_m - T_s) = 82.6 \text{ W/m}^2 \cdot \text{K} (1000 - 350) \text{ K} = 53,700 \text{ W/m}^2. \quad <$$

(b) From continuity,

$$\dot{m} = (\rho u_m A)_a = (\rho u_m A)_b \quad u_m)_b = u_m)_a (\rho A)_a / (\rho A)_b = 60 \text{ m/s} (40/20) = 120 \text{ m/s}.$$

For each of the resulting channels,  $D_h = 0.02 \text{ m}$  and

$$\text{Re}_{D_h} = \frac{\rho u_m D_h}{\mu} = \frac{0.348 \text{ kg/m}^3 (120 \text{ m/s}) 0.02 \text{ m}}{424.4 \times 10^{-7} \text{ kg/s}\cdot\text{m}} = 19,680.$$

Since the flow is still turbulent,

$$\text{Nu}_D = 0.023(19,680)^{4/5} (0.726)^{0.3} = 56.9 \quad h = \frac{56.9(0.0667 \text{ W/m}\cdot\text{K})}{0.02 \text{ m}} = 189.8 \text{ W/m}^2 \cdot \text{K}$$

$$q'' = 189.8 \text{ W/m}^2 \cdot \text{K} (1000 - 350) \text{ K} = 123,400 \text{ W/m}^2. \quad <$$

**COMMENTS:** From the Dittus-Boelter equation,

$$h_b / h_a = (u_{m,b} / u_{m,a})^{0.8} (D_{h,a} / D_{h,b})^{0.2} = (2)^{0.8} (4)^{0.2} = 1.74 \times 1.32 = 2.30.$$

Hence, heat transfer enhancement due to the insert is primarily a result of the increase in  $u_m$  and secondarily a result of the decrease in  $D_h$ .

### PROBLEM 8.85

**KNOWN:** Temperature, pressure and flow rate of air entering a rectangular duct of prescribed dimensions and surface temperature.

**FIND:** Air outlet temperature and duct heat transfer rate.

**SCHEMATIC:**

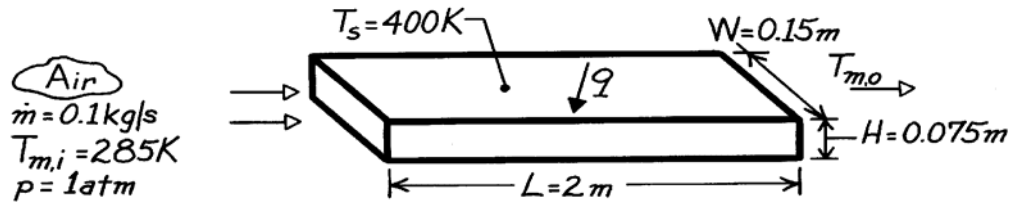

**ASSUMPTIONS:** (1) Steady-state conditions, (2) Constant properties, (3) Uniform surface temperature, (4) Fully developed flow throughout, (5) Ideal gas with negligible viscous dissipation and pressure variation.

**PROPERTIES:** Table A-4, Air (assume  $T_m \approx 325\text{K}$ , 1 atm):  $c_p = 1008\text{ J/kg}\cdot\text{K}$ ,  $\mu = 196.4 \times 10^{-7}\text{ N}\cdot\text{s/m}^2$ ,  $k = 0.0282\text{ W/m}\cdot\text{K}$ ,  $\text{Pr} = 0.707$ .

**ANALYSIS:** From Eqs. 8.66 and 8.1,

$$D_h = \frac{4 A_c}{P} = \frac{4 \times (0.15 \times 0.075)\text{ m}^2}{2(0.15 + 0.075)\text{ m}} = 0.10\text{ m}$$

$$\text{Re}_D = \frac{\rho u_m D_h}{\mu} = \frac{\dot{m} D_h}{A_c \mu} = \frac{0.1\text{ kg/s}(0.1\text{ m})}{(0.15\text{ m} \times 0.075\text{ m})196.4 \times 10^{-7}\text{ N}\cdot\text{s/m}^2} = 45,260.$$

Hence the flow is turbulent, and from Eq. 8.60

$$h = \frac{k}{D_h} 0.023 \text{Re}_D^{4/5} \text{Pr}^{0.4} = \frac{0.0282\text{ W/m}\cdot\text{K}}{0.10\text{ m}} 0.023(45,260)^{4/5} (0.707)^{0.4} = 30\text{ W/m}^2\cdot\text{K}.$$

From Eq. 8.41b, with  $P = 2(W + H)$ ,

$$T_{m,o} = T_s - (T_s - T_{m,i}) \exp\left(-\frac{PL}{\dot{m} c_p} \bar{h}\right)$$

$$T_{m,o} = 400\text{ K} - (400 - 285)\text{ K} \exp\left[-\frac{2(0.15\text{ m} + 0.075\text{ m})2\text{ m}(30\text{ W/m}^2\cdot\text{K})}{0.1\text{ kg/s} \times 1008\text{ J/kg}\cdot\text{K}}\right]$$

$$T_{m,o} = 312\text{ K} \quad <$$

and from Eq. 8.34

$$q = \dot{m} c_p (T_{m,o} - T_{m,i}) = 0.1\text{ kg/s} \times 1008\text{ J/kg}\cdot\text{K} (312 - 285)\text{ K} = 2724\text{ W}. \quad <$$

**COMMENTS:** (1) The calculations may be checked by determining  $q$  from Eqs. 8.43 and 8.44. We obtain  $\Delta T_{\ell m} = 101^\circ\text{C}$  and  $q = 2724\text{ W}$ .

(2)  $\bar{T}_m$  has been over-estimated. The calculations should be repeated with properties evaluated at  $\bar{T}_m = 299\text{ K}$ .

## PROBLEM 8.86

**KNOWN:** Dimensions of semi-circular copper tubes in contact at plane surfaces. Thermal contact resistance. Tube flow conditions.

**FIND:** (a) Heat rate per unit tube length, and (b) The effect on the heat rate when the fluids are ethylene glycol, the exchanger tube is fabricated from an aluminum alloy, or the exchanger tube thickness is increased.

**SCHEMATIC:**

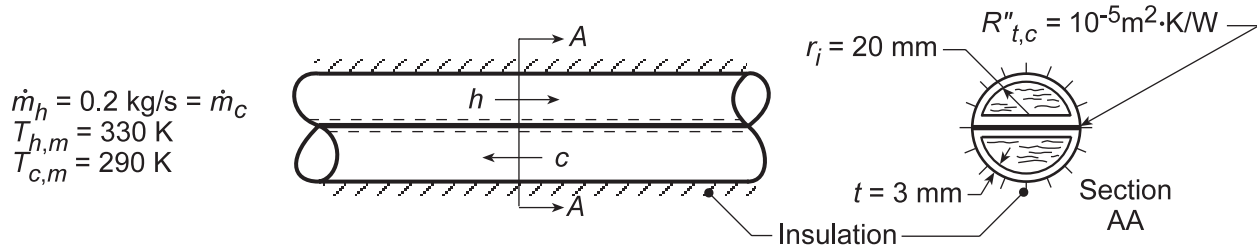

**ASSUMPTIONS:** (1) Steady-state conditions, (2) Constant properties, (3) Adiabatic outer surface, (4) Fully developed flow, (5) Negligible heat loss to surroundings.

**PROPERTIES:** Table A.1, Copper ( $T \approx 300$  K):  $k = 400$  W/m·K; Water (given):  $\mu = 800 \times 10^{-6}$  kg/s·m,  $k = 0.625$  W/m·K,  $Pr = 5.35$ .

**ANALYSIS:** (a,b) Heat transfer from the hot to cold fluids is *enhanced* by conduction through the semi-circular portions of the tube walls. The walls may be approximated as straight fins with an insulated tip, and the thermal circuit is shown below.

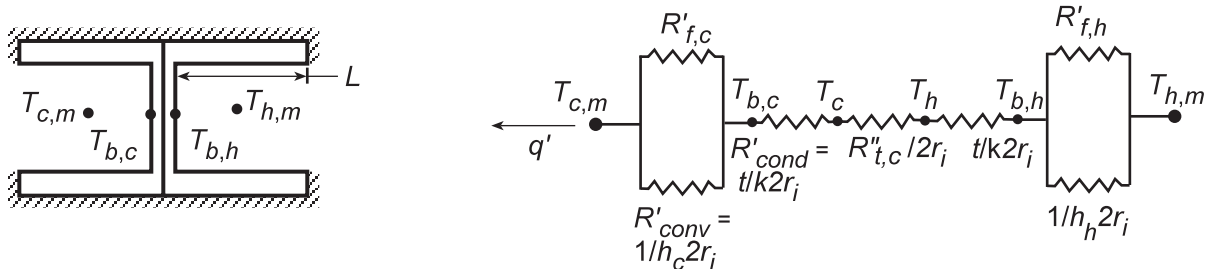

Note that, since each semi-circular surface is insulated on one side, surfaces may be combined to yield a *single* fin of thickness  $2t$  with convection on both sides. Also, due to the equivalent geometry and the assumption of constant properties, there is symmetry on opposite sides of the contact resistance. From the thermal circuit, the heat rate is

$$q' = \frac{T_{h,m} - T_{c,m}}{R'_{tot}} \quad (1)$$

For flow through the semi-circular tube,

$$\begin{aligned} Re_D &= \frac{\rho u_m D_h}{\mu} = \frac{\dot{m} D_h}{A_c \mu} = \frac{4 \dot{m} A_c}{A_c P \mu} = \frac{4 \dot{m}}{P \mu} = \frac{4 \dot{m}}{(2r_i + \pi r_i) \mu} \\ Re_D &= \frac{4 \times 0.2 \text{ kg/s}}{(2 + \pi) 0.02 \text{ m} \times 800 \times 10^{-6} \text{ kg/s} \cdot \text{m}} = 9725 \end{aligned} \quad (2)$$

the flow is turbulent. Using the Gnielinski correlation, since  $Re_D < 10,000$

$$Nu_D = \frac{(f/8)(Re_D - 1000) Pr}{1 + 12.7(f/8)^{1/2} (Pr^{2/3} - 1)} = 69.9 \quad (3)$$

Continued...

**PROBLEM 8.86 (Cont.)**

where  $f = (0.79 \ln(\text{Re}_D) - 1.64)^{-2} = 0.0317$

$$D_h = \frac{4A_c}{P} = \frac{4(\pi r_1^2/2)}{(\pi + 2)r_1} = \frac{2\pi}{\pi + 2} 0.02 \text{ m} = 0.0244 \text{ m} \quad (4)$$

$$h = \text{Nu}_D \frac{k}{D_h} = 69.9 \frac{0.625}{0.0244} = 1790 \text{ W/m}^2 \cdot \text{K} \quad (5)$$

Find now values for the thermal resistance of the circuit.

$$R'_{\text{conv}} = \frac{1}{2r_1 h} = \frac{1}{(0.04 \text{ m}) 1790 \text{ W/m}^2 \cdot \text{K}} = 0.0140 \text{ m} \cdot \text{K/W} \quad (6)$$

$$R'_{\text{fin}} = \frac{\theta_b}{q'_f} = \frac{1}{(hP'kA'_c)^{1/2} \tanh(hP/kA_c)L} \quad (7)$$

$$L = \pi r_1/2 = \pi(0.01 \text{ m}) = 0.0314 \text{ m} \quad A_c = 2t \cdot 1 \text{ m} = 0.006 \text{ m}^2 \quad P \approx 2.1 \text{ m} \quad (8,9,10)$$

$$(hP'kA'_c)^{1/2} = \left(1790 \text{ W/m}^2 \cdot \text{K} \times 2 \text{ m/m} \times 400 \text{ W/m} \cdot \text{K} \times 0.006 \text{ m}^2/\text{s}\right)^{1/2} = 92.7 \text{ W/K} \cdot \text{m}$$

$$(hP/kA_c)^{1/2} L = \left(1790 \text{ W/m}^2 \cdot \text{K} \times 2 \text{ m} / 400 \text{ W/m} \cdot \text{K} \times 0.006 \text{ m}^2\right)^{1/2} 0.0314 \text{ m} = 1.21$$

$$R'_{\text{fin}} = \frac{1}{92.7 \text{ W/m} \cdot \text{K} (0.838)} = 0.0129 \text{ m} \cdot \text{K/W} \quad (11)$$

$$R'_{\text{cond}} = \frac{t}{2kr_1} = \frac{0.003 \text{ m}}{2(400 \text{ W/m} \cdot \text{K})(0.02 \text{ m})} = 1.875 \times 10^{-4} \text{ m} \cdot \text{K/W} \quad (12)$$

$$R'_{t,c} = \frac{R''_{t,c}}{2r_1} = \frac{10^{-5} \text{ m}^2 \cdot \text{K/W}}{2(0.02 \text{ m})} = 2.5 \times 10^{-4} \text{ m} \cdot \text{K/W} \quad (13)$$

The equivalent resistance of the parallel circuit is

$$R'_{\text{eq}} = \left(R'_{\text{fin}}{}^{-1} + R'_{\text{conv}}{}^{-1}\right)^{-1} = \left(77.6 \text{ W/m} \cdot \text{K} + 71.5 \text{ W/m} \cdot \text{K}\right)^{-1} = 6.70 \times 10^{-3} \text{ m} \cdot \text{K/W} \quad (14)$$

Hence

$$R'_{\text{tot}} = 2\left(R'_{\text{eq}} + R'_{\text{cond}}\right) + R'_{t,c} \quad (15)$$

$$R'_{\text{tot}} = \left[2\left(6.70 \times 10^{-3} + 1.875 \times 10^{-4}\right) + 2.50 \times 10^{-4}\right] \text{ m} \cdot \text{K/W} = 0.0140 \text{ m} \cdot \text{K/W}$$

$$q' = \frac{(330 - 290) \text{ K}}{0.0140 \text{ m} \cdot \text{K/W}} = 2850 \text{ W/m} \cdot \text{K} \quad \leftarrow$$

(c) Using the *IHT Workspace* with the foregoing equations, analyses were performed and the results summarized in the table below. The “Conditions” are described below; the “Change” is relative to the base case condition.

Continued ...



### PROBLEM 8.86 (Cont.)

Condition*	$R'_{\text{conv}} \times 10^4$ (m·K/W)	$R'_{\text{fin}} \times 10^4$ (m·K/W)	$R'_{\text{cond}} \times 10^4$ (m·K/W)	$R'_{\text{tot}} \times 10^4$ (m·K/W)	$R'_{\text{eq}} \times 10^4$ (m·K/W)	$q'$ (W/m)	Change (%)
Base case	140	129	1.88	140	67.0	2850	--
Ethylene glycol	6550	4210	1.88	5130	2560	77.9	-97
Aluminum alloy	140	171	4.24	165	76.9	2430	-15
Thicker tube	140	120	2.50	136	64.4	2930	+2.8

\*Conditions: change from base case

Base case - water, copper ( $k = 400 \text{ W/m}\cdot\text{K}$ ),  $t = 3 \text{ mm}$

Ethylene glycol - ethylene glycol instead of water,  $Re_D = 727$ , laminar,  $Nu_D = 3.66$  estimated

Aluminum alloy - alloy ( $k = 177 \text{ W/m}\cdot\text{K}$ ) instead of copper

Thicker tube -  $t = 4 \text{ mm}$  instead of  $3 \text{ mm}$

As expected, using ethylene glycol as the working fluid would decrease the heat rate, especially because the flow becomes laminar. Note that  $R'_{\text{conv}}$  is the dominate resistance since the convection coefficient is considerably reduced compared to that with water. Using aluminum alloy, rather than copper, as the tube material reduces the heat rate by 14%. Conduction-convection (fin) in the tube wall is important as can be seen by examining the change in  $R'_{\text{fin}}$  relative to the base condition. Increasing the tube wall thickness for the copper tube exchanger from 3 to 4 mm had only a marginal positive effect on the heat rate.

**COMMENTS:** A more accurate calculation would account for the absence of symmetry about the contact plane. Evaluation of water properties at  $T_{h,m} = 330 \text{ K}$  and  $T_{c,m} = 290 \text{ K}$  yields  $h_h = 1930 \text{ W/m}^2\cdot\text{K}$  and  $h_c = 1470 \text{ W/m}^2\cdot\text{K}$ .

### PROBLEM 8.87

**KNOWN:** Rectangular channel with constant surface temperature. Aspect ratio.

**FIND:** Which aspect ratio channel provides the largest heat transfer rate. Whether this is greater than, equal to, or less than the heat transfer rate for a circular tube.

**SCHEMATIC:**

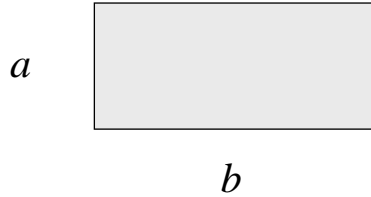

**ASSUMPTIONS:** (1) Steady-state, (2) Incompressible flow, (3) Laminar, (4) Fully-developed.

**ANALYSIS:** The heat transfer rate is given by  $q_s = \dot{m}c_p(T_{m,o} - T_{m,i})$ , where from Eq. 8.41b with constant heat transfer coefficient,

$$T_{m,o} - T_{m,i} = (T_s - T_{m,i}) \left[ 1 - \exp\left(-\frac{hPL}{\dot{m}c_p}\right) \right]$$

Thus, the heat transfer rate increases with increasing values of

$$\frac{hPL}{\dot{m}c_p} = \frac{Nu_k PL}{\dot{m}c_p D_h} = \frac{Nu_k P^2 L}{4\dot{m}c_p A_c}$$

For fixed mass flow rate and length, and assuming the same properties, the relevant parameter that determines the heat transfer rate is therefore  $NuP^2/A_c$ . For a rectangular channel,  $P^2/A_c = 4(a+b)^2/ab = 4(1+b/a)^2/(b/a)$ , whereas for a circular tube,  $P^2/A_c = 4\pi$ . The table below compares values of  $NuP^2/A_c$  for the three different aspect ratio rectangular channels and a circular tube.

$b/a$	$Nu$	$P^2/A_c$	$NuP^2/A_c$
1.0	2.98	16	47.7
1.43	3.08	16.5	50.9
2.0	3.39	18	61.0
Circular tube	3.66	12.6	46.0

The rectangular channel with  $b/a = 2.0$  provides the largest heat transfer rate, which is larger than for a circular tube. <

**COMMENTS:** The Nusselt numbers for the rectangular channel are all less than 3.66 for the circular tube, but their convective heat transfer rates are larger than that of the circular tube because their  $P^2/A_c$  values are larger.

### PROBLEM 8.88

**KNOWN:** Heat exchanger to warm blood from a storage temperature  $10^\circ\text{C}$  to  $37^\circ$  at  $200\text{ ml/min}$ . Tubing has rectangular cross-section  $6.4\text{ mm} \times 1.6\text{ mm}$  sandwiched between plates maintained at  $40^\circ\text{C}$ .

**FIND:** (a) Length of tubing and (b) Assessment of assumptions to indicate whether analysis under- or over-estimates length.

**SCHEMATIC:**

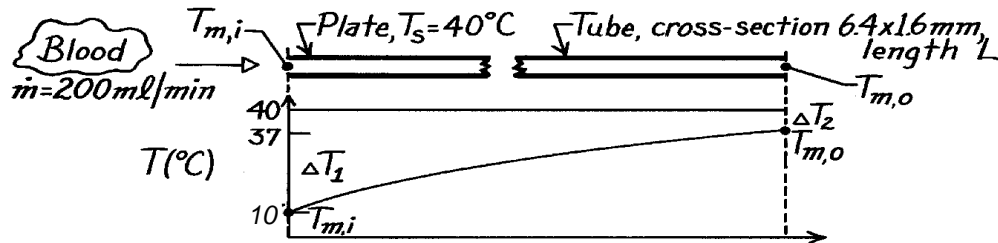

**ASSUMPTIONS:** (1) Steady-state conditions, (2) Incompressible liquid with negligible viscous dissipation, (3) Blood flow is fully developed, (4) Blood has properties of water, and (5) Negligible tube wall and contact resistance.

**PROPERTIES:** Table A-6, Water ( $\bar{T}_m \approx 300\text{ K}$ ):  $c_{p,f} = 4179\text{ J/kg}\cdot\text{K}$ ,  $\rho_f = 1/v_f = 997\text{ kg/m}^3$ ,  $v_f = \mu_f/\nu_f = 8.58 \times 10^{-7}\text{ m}^2/\text{s}$ ,  $k = 0.613\text{ W/m}\cdot\text{K}$ ,  $\text{Pr} = 5.83$ .

**ANALYSIS:** (a) From an overall energy balance and the rate equation,

$$q = \dot{m} c_p (T_{m,o} - T_{m,i}) = \bar{h} A_s \Delta T_{\text{LMTD}} \quad (1)$$

where

$$\Delta T_{\text{LMTD}} = \frac{\Delta T_1 - \Delta T_2}{\ln(\Delta T_1 / \Delta T_2)} = \frac{(40 - 15) - (40 - 37)}{\ln(25/3)} = 11.7^\circ\text{C}.$$

To estimate  $\bar{h}$ , find the Reynolds number for the rectangular tube,

$$\text{Re}_D = \frac{u_m D_h}{\nu} = \frac{0.326\text{ m/s} \times 0.00256\text{ m}}{8.58 \times 10^{-7}\text{ m}^2/\text{s}} = 973$$

where

$$D_h = 4 A_c / P = 4(6.4\text{ mm} \times 1.6\text{ mm}) / 2(6.4 + 1.6)\text{ mm} = 2.56\text{ mm}$$

$$A_c = (6.4\text{ mm} \times 1.6\text{ mm}) = 1.024 \times 10^{-5}\text{ m}^2$$

$$u_m = \dot{m} / \rho A_c = \dot{V} / A_c = 200\text{ ml} / 60\text{ s} \left( 10^{-6}\text{ m}^3 / \text{ml} \right) / 1.024 \times 10^{-5}\text{ m}^2 = 0.326\text{ m/s}.$$

Hence the flow is laminar, but assuming fully developed flow with an isothermal surface from Table 8.1 with  $b/a = 6.4/1.6 = 4$ ,

$$\text{Nu}_D = \frac{h D_h}{k} = 4.44 \quad h = \frac{4.44 \times 0.613\text{ W/m}\cdot\text{K}}{0.00256\text{ m}} = 1063\text{ W/m}^2\cdot\text{K}.$$

Continued ...

### PROBLEM 8.88 (Cont.)

From Eq. (1) with

$$A_s = PL = 2(6.4 + 1.6) \times 10^{-3} \text{ m} \times L = 1.6 \times 10^{-2} L$$

$$\dot{m} = \rho A_c u_m = 997 \text{ kg/m}^3 \times 1.024 \times 10^{-5} \text{ m}^2 \times 0.326 \text{ m/s} = 3.328 \times 10^{-3} \text{ kg/s}$$

the length of the rectangular tubing can be found from Eq. (1) as

$$3.328 \times 10^{-3} \text{ kg/s} \times 4179 \text{ J/kg} \cdot \text{K} (37 - 10) \text{ K} = 1063 \text{ W/m}^2 \cdot \text{K} \times 1.6 \times 10^{-2} L \text{ m}^2 \times 11.7 \text{ K}$$

$$L = 1.9 \text{ m.}$$

<

(b) Consider these comments with regard to whether the analysis under- or over-estimates the length,

- ⇒ With  $x_{fd,h} \approx 0.05 D_h$ ,  $Re_D = 0.12 \text{ m}$  and  $x_{fd,t} = x_{fd,h}$ ,  $Pr = 0.73$ , the thermal development may not be negligible and would contribute to increasing heat transfer; the present analysis over predicts the length,
- ⇒ negligible tube wall resistance - depends upon materials of construction; if plastic, analysis under predicts length,
- ⇒ negligible thermal contact resistance between tube and heating plate - if present, analysis under predicts length.

### PROBLEM 8.89

**KNOWN:** Coolant flowing through a rectangular channel (gallery) within the body of a mold.

**FIND:** Convection coefficient when the coolant is process water or ethylene glycol.

**SCHEMATIC:**

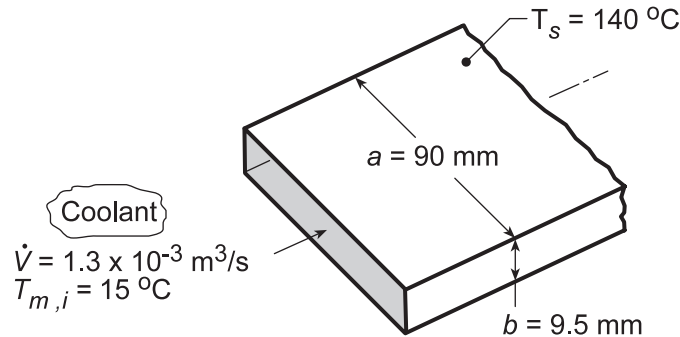

**ASSUMPTIONS:** (1) Gallery can be approximated as a rectangular channel with a uniform surface temperature, (2) Fully developed flow conditions.

**PROPERTIES:** Table A.6, Water ( $\bar{T}_m = (140 + 15)^\circ\text{C}/2 = 350\text{ K}$ ):  $\rho = 974\text{ kg/m}^3$ ,  $\mu = 365 \times 10^{-6}\text{ N}\cdot\text{s/m}^2$ ,  $\nu = \mu/\rho = 3.749 \times 10^{-7}\text{ m}^2/\text{s}$ ,  $k = 0.668\text{ W/m}\cdot\text{K}$ ,  $\text{Pr} = 2.29$ ; Table A.5, Ethylene glycol ( $\bar{T}_m = 350\text{ K}$ ):  $\rho = 1079\text{ kg/m}^3$ ,  $\nu = 3.17 \times 10^{-6}\text{ m}^2/\text{s}$ ,  $k = 0.261\text{ W/m}\cdot\text{K}$ ,  $\text{Pr} = 34.6$ .

**ANALYSIS:** The characteristic length of the channel, the hydraulic diameter, Eq. 8.66, is  $D_h = 4A_c/P$  where  $A_c$  is the cross-sectional flow area and  $P$  is the wetted perimeter. For our channel,

$$D_h = \frac{4(a \times b)}{2(a + b)} = \frac{4 \times 0.090\text{ m} \times 0.0095\text{ m}}{2(0.090 + 0.0095)\text{ m}} = 0.0172\text{ m}$$

For the *water* coolant, from the continuity equation, find the Reynolds number to characterize the flow

$$u_m = \frac{\dot{V}}{A_c} = \frac{1.3 \times 10^{-3}\text{ m}^3/\text{s}}{0.090\text{ m} \times 0.0095\text{ m}} = 1.52\text{ m/s}$$

$$\text{Re}_{D_h} = \frac{u_m D_h}{\nu} = \frac{1.52\text{ m/s} \times 0.0172\text{ m}}{3.749 \times 10^{-7}\text{ m}^2/\text{s}} = 69,736$$

Since the flow is turbulent, and assuming fully developed conditions, use the Dittus-Boelter correlation, Eq. 8.60, to estimate the convection coefficient,

$$\text{Nu}_{D_h} = \frac{h D_h}{k} = 0.023 \text{Re}_{D_h}^{0.8} \text{Pr}^{0.4} = 0.023 (69,736)^{0.8} (2.29)^{0.4} = 240$$

$$h_w = \frac{0.668\text{ W/m}\cdot\text{K}}{0.0172\text{ m}} \times 240 = 9326\text{ W/m}^2\cdot\text{K} \quad <$$

Repeating the calculations using properties for the *ethylene glycol* coolant, find

$$\text{Re}_{D_h} = 8,247 \quad \text{Nu}_{D_h} = 128 \quad h_{eg} = 1957\text{ W/m}^2\cdot\text{K} \quad <$$

Continued...

### PROBLEM 8.89 (Cont.)

**COMMENTS:** (1) The convection coefficient for the *water* coolant is more than 4 times greater than that with the *ethylene glycol* coolant. The corrosion protection afforded by the latter coolant greatly compromises the thermal performance of the gallery. In such situations, it is useful to explore a compromise between corrosion protection and thermal performance by using an aqueous solution of ethylene glycol (50%-50%, for example).

(2) Recognize that for the ethylene glycol coolant calculation the Reynolds number is slightly below the lower limit of applicability of the Dittus-Boelter correlation, and the Gnielinski correlation would be more accurate.

### PROBLEM 8.90

**KNOWN:** Heat sink with 20 passages for air flow removes power dissipation from circuit board.

**FIND:** Operating temperature of the board and pressure drop across the sink.

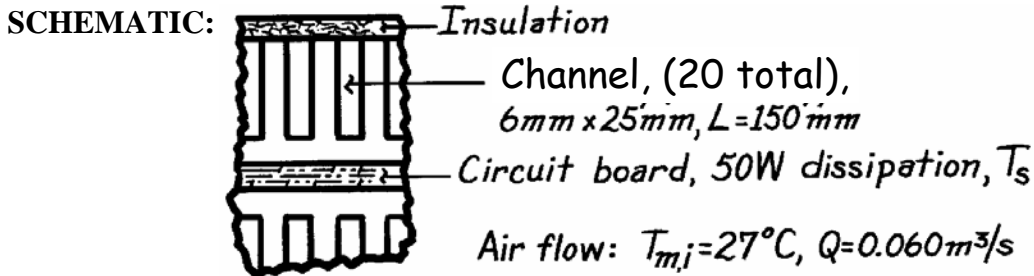

**ASSUMPTIONS:** (1) Steady-state conditions, (2) Ideal gas with negligible viscous dissipation and pressure variation, (3) Negligible thermal resistance between the circuit boards and air passages, (4) Sink surface and board are isothermal at  $T_s$ .

**PROPERTIES:** Table A-4, Air ( $\bar{T} \approx 310\text{ K}$ , 1 atm):  $\rho = 1.1281\text{ kg/m}^3$ ,  $c_p = 1008\text{ J/kg}\cdot\text{K}$ ,  $\nu = 16.89 \times 10^{-6}\text{ m}^2/\text{s}$ ,  $k = 0.0270\text{ W/m}\cdot\text{K}$ ,  $\text{Pr} = 0.706$ .

**ANALYSIS:** The air outlet temperature follows from Eq. 8.41b,

$$\frac{T_s - T_{m,o}}{T_s - T_{m,i}} = \exp\left(-\frac{PL\bar{h}}{\dot{m}c_p}\right).$$

The mass flow rate for both heat sinks is

$$\dot{m} = \rho\dot{V} = 1.1281\text{ kg/m}^3 \times 0.060\text{ m}^3/\text{s} = 6.77 \times 10^{-2}\text{ kg/s}$$

and the Reynolds number for a rectangular passage is

$$\text{Re}_D = \frac{u_m D_h}{\nu}$$

where  $D_h = 4A_c/P = 4(6\text{ mm} \times 25\text{ mm})/2(6 + 25)\text{ mm} = 9.68\text{ mm}$

$$u_m = \frac{\dot{m}/20}{\rho A_c} = \frac{6.77 \times 10^{-2}\text{ kg/s}/20}{1.1281\text{ kg/m}^3 (6 \times 25) \times 10^{-6}\text{ m}^2} = 20.0\text{ m/s}$$

giving  $\text{Re}_D = \frac{20.0\text{ m/s} \times 9.68 \times 10^{-3}\text{ m}}{16.89 \times 10^{-6}\text{ m}^2/\text{s}} = 11,460$ .

Assume the flow is turbulent and fully developed and using the Dittus-Boelter correlation find

$$\text{Nu}_D = 0.023\text{Re}^{4/5}\text{Pr}^{0.4} = 0.023(11,460)^{4/5}(0.706)^{0.4} = 35.4$$

$$h = \frac{\text{Nu} \cdot k}{D_h} = \frac{35.4 \times 0.027\text{ W/m}\cdot\text{K}}{0.00968\text{ m}} = 98.6\text{ W/m}^2 \cdot \text{K}.$$

Continued ...

### PROBLEM 8.90 (Cont.)

From an overall energy balance on the sink,

$$q = \dot{m} c_p (T_{m,o} - T_{m,i}) \quad T_{m,o} = T_{m,i} + q/\dot{m} c_p$$

$$T_{m,o} = 27^\circ\text{C} + 50 \text{ W}/6.77 \times 10^{-2} \text{ kg/s} \times 1008 \text{ J/kg} \cdot \text{K} = 27.73^\circ\text{C}$$

Hence, the operating temperature of the circuit board for these conditions is

$$\frac{T_s - 27.73}{T_s - 27} = \exp \left[ - \frac{2(6 + 25) \times 10^{-3} \text{ m} \times 0.150 \text{ m} \times 98.6 \text{ W/m}^2 \cdot \text{K}}{(6.77 \times 10^{-2} \text{ kg/s}/20) \times 1008 \text{ J/kg} \cdot \text{K}} \right]$$

$$T_s = 30.1^\circ\text{C}. \quad <$$

The pressure drop in the rectangular passage for the smooth surface condition follows from Eqs. 8.22 and 8.21

$$\Delta p = f \frac{\rho u_m^2 L}{D_h}$$

where

$$f = (0.790 \ln(\text{Re}_D) - 1.64)^{-2} = 0.032.$$

$$\Delta p = 0.0320 \frac{1.1281 \text{ kg/m}^3 (20.0 \text{ m/s})^2}{0.00968 \text{ m}} \times 0.150 \text{ m} = 224 \text{ N/m}^2. \quad <$$

**COMMENTS:** (1) The analysis has been simplified by assuming the channel is rectangular and all four sides experience heat transfer. Since the insulated surface is a small portion of the total passage surface area, the effect can't be very large. (2) The power required to move the air through the heat sink is  $P_{\text{elec}} = \dot{V} \Delta p = 0.060 \text{ m}^3/\text{s} \times 224 \text{ N/m}^2 = 13.4 \text{ W}$ . (3) The assumption  $\bar{T} \approx 310 \text{ K}$  for evaluating properties is an overestimate. The calculation could be repeated for  $\bar{T} = 300 \text{ K}$  for greater accuracy.



## PROBLEM 8.91

**KNOWN:** Channel formed between metallic blades dissipating heat by internal volumetric generation.

**FIND:** (a) The heat removal rate per blade for the prescribed thermal conditions and (b) Time required to slow a train of mass  $10^6$  kg from 120 km/h to 50 km/h.

**SCHEMATIC:**

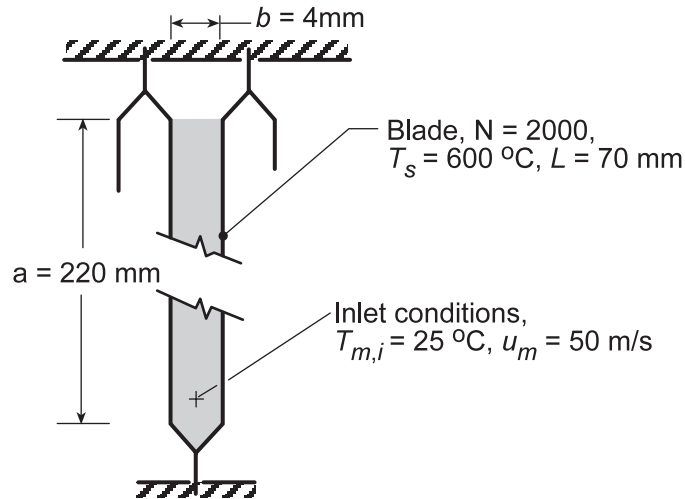

**ASSUMPTIONS:** (1) Steady-state conditions for channel blades and air flow, (2) The blades form a channel of rectangular ( $a \times b$ ) cross-section and length  $L$ , (3) Ideal gas with negligible viscous dissipation, pressure variation, and axial conduction, and (4) Fully developed flow conditions in the channel.

**PROPERTIES:** Table A.4, Air ( $\bar{T}_m \approx 350$  K, 1 atm):  $\rho = 0.995$  kg/m<sup>3</sup>,  $c_p = 1009$  J/kg · K,  $\nu = 20.92 \times 10^{-6}$  m<sup>2</sup>/s,  $k = 0.030$  W/m · K,  $Pr = 0.700$ .

**ANALYSIS:** (a) The heat removal rate by the air from a single channel (one blade) follows from an overall energy balance,

$$q = \dot{m}c_p(T_{m,o} - T_{m,i}) \quad (1)$$

where the outlet temperature can be determined from Eq. 8.41b,

$$\frac{T_s - T_{m,o}}{T_s - T_{m,i}} = \exp\left(-\frac{PL}{\dot{m}c_p}\bar{h}\right) \quad (2)$$

The hydraulic diameter,  $D_h$ , follows from Eq. 8.66,

$$D_h = \frac{4A_c}{P} = \frac{4(a \times b)}{2(a + b)} = \frac{4(0.220 \times 0.004) \text{ m}^2}{2(0.220 + 0.004) \text{ m}} = 0.0079 \text{ m} \quad (3)$$

Assuming  $\bar{T}_m = 350$  K, the Reynolds number is

$$Re_{D_h} = \frac{u_m D_h}{\nu} = \frac{50 \text{ m/s} \times 0.0079 \text{ m}}{20.92 \times 10^{-6} \text{ m}^2/\text{s}} = 18,779 \quad (4)$$

Using the Dittus-Boelter correlation, Eq. 8.60,

$$Nu_{D_h} = \frac{\bar{h}D_h}{k} = 0.023 Re_{D_h}^{0.8} Pr^{0.4} = 0.023(18,779)^{0.8} (0.700)^{0.4} = 52.37 \quad (5)$$

Continued...

**PROBLEM 8.91 (Cont.)**

$$\bar{h} = \frac{0.030 \text{ W/m} \cdot \text{K}}{0.0079 \text{ m}} \times 52.37 = 199 \text{ W/m}^2 \cdot \text{K}$$

Hence, the outlet temperature is

$$\frac{600 - T_{m,o}}{(600 - 25)^\circ \text{C}} = \exp\left(-\frac{2(0.220 + 0.004) \text{ m} \times 0.070 \text{ m}}{0.0438 \text{ kg/s} \times 1009 \text{ J/kg} \cdot \text{K}} 199 \text{ W/m}^2 \cdot \text{K}\right)$$

$$T_{m,o} = 100.7^\circ \text{C}$$

where

$$\dot{m} = \rho A_c u_m = 0.995 \text{ kg/m}^3 \times (0.220 \times 0.004) \text{ m}^2 \times 50 \text{ m/s} = 0.0438 \text{ kg/s}$$

and the rate of heat removal per blade, from Eq. (1), is

$$q = 0.0438 \text{ kg/s} \times 1009 \text{ J/kg} \cdot \text{K} (100.7 - 25)^\circ \text{C} = 3.346 \text{ kW} \quad <$$

(b) From an energy balance on the locomotive over an interval of time,  $\Delta t$ , the heat energy transferred to the air stream results in a change in kinetic energy of the train,

$$-E_{\text{out}} = \Delta E = KE_f - KE_i \quad (6)$$

$$-(q \times N) \times \Delta t = \frac{1}{2} M (V_f^2 - V_i^2)$$

$$-3346 \text{ W/blade} \times 2000 \text{ blades} \times \Delta t (\text{s}) = \frac{1}{2} \times 10^6 \text{ kg} \left[ \left( \frac{50,000}{3600} \right)^2 - \left( \frac{120,000}{3600} \right)^2 \right] \text{ m}^2/\text{s}^2$$

$$\Delta t = 69 \text{ s} \quad <$$

**COMMENTS:** (1) For the channel,  $L/D_h = 0.070 \text{ m}/0.0079 \text{ m} = 8.9 < 10$  so that the assumption of fully developed conditions may not be satisfied. Recognize that the flow at the channel entrance may be highly turbulent because of the upstream fan swirl and ducting.

(2) What benefits could be realized by increasing the heat transfer coefficient? Aside from increasing velocity, what design changes would you make to increase  $h$ ?

(3) Our assumption for  $\bar{T}_m = 350 \text{ K}$  at which to evaluate properties is reasonable considering  $T_m = (100.7 + 25)^\circ \text{C}/2 = 335 \text{ K}$ .

## PROBLEM 8.92

**KNOWN:** Printed-circuit board (PCB) with uniform temperature  $T_s$  cooled by laminar, fully developed flow in a parallel-plate channel. The air flow with an inlet temperature of  $T_{m,i}$  is driven by a pressure difference,  $\Delta p$ .

**FIND:** The average heat removal rate per unit area,  $\bar{q}_s''$  ( $\text{W}/\text{m}^2$ ), from the PCB.

**SCHEMATIC:**

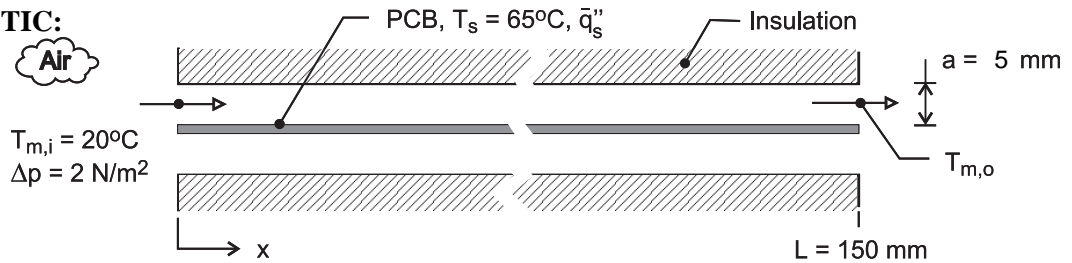

**ASSUMPTIONS:** (1) Laminar, fully developed flow, (2) Upper and lower walls of the channel are insulated and of infinite extent in the transverse direction, (3) PCB has uniform surface temperature, (4) Constant properties, (5) Ideal gas with negligible viscous dissipation.

**PROPERTIES:** Table A-4, Air ( $T_m = 293 \text{ K}$ , 1 atm):  $\rho = 1.192 \text{ kg/m}^3$ ,  $c_p = 1007 \text{ J/kg}\cdot\text{K}$ ,  $\nu = 1.531 \times 10^{-5} \text{ m}^2/\text{s}$ ,  $k = 0.0258 \text{ W/m}\cdot\text{K}$ ,  $\text{Pr} = 0.709$ .

**ANALYSIS:** The energy equations for determining the heat rate from one surface of the board are Eqs. 8.34 and 8.41b

$$q = \dot{m} c_p (T_{m,o} - T_{m,i}) = \bar{q}_s'' A_s \quad (1)$$

$$\frac{T_s - T_{m,o}}{T_s - T_{m,i}} = \exp\left(-\frac{P_h L \bar{h}}{\dot{m} c_p}\right) \quad (2)$$

where  $A_s = Lw$  and  $P = w$ , since heat transfer is only from one surface, where  $w$  is the width in the transverse direction. For the fully developed flow condition, the velocity is estimated from the friction pressure drop relation, Eq. 8.22a,

$$\Delta p = f \left( \rho u_m^2 / 2 \right) (L / D_h) \quad (3)$$

where the hydraulic diameter for the channel cross section is

$$D_h = \frac{4 A_c}{P} = \frac{4(w a)}{2(w + a)} = 2a \quad a \ll w$$

The friction factor  $f$  from Table 8.1 for the cross section  $b/a = \infty$  is

$$f \cdot \text{Re}_{D_h} = 96 \quad (4)$$

where the Reynolds number is

$$\text{Re}_{D_h} = u_m D_h / \nu \quad (5)$$

Continued ...

### PROBLEM 8.92 (Cont.)

and the flow rate through one channel is

$$\dot{m} = \rho A_c u_m = \rho (wa) u_m \quad (6)$$

For fully developed laminar flow from Table 8.1.

$$\overline{Nu}_D = \bar{h} D_h / k = 4.86 \quad (7)$$

Substituting Eqs. (4) and (5) into Eq. (3) and solving for  $u_m$  yields

$$u_m = \Delta p D_h^2 / 48 \nu \rho L = 2 \text{ N/m}^2 \times (0.01 \text{ m})^2 / 48 \times 1.531 \times 10^{-5} \text{ m}^2/\text{s} \times 1.192 \text{ kg/m}^3 \times 0.15 \text{ m} = 1.52 \text{ m/s}$$
$$Re = u_m D_h / \nu = 1.52 \text{ m/s} \times 0.01 \text{ m} / 1.531 \times 10^{-5} \text{ m}^2/\text{s} = 994$$

Thus the flow is laminar, as assumed. From Eqs. (6), (7), and (2),  $\dot{m}/w = \rho u_m a = 1.192 \text{ kg/m}^3 \times 1.52 \text{ m/s} \times 0.005 \text{ m} = 0.00907 \text{ kg/s}\cdot\text{m}$ .  $\bar{h} = \overline{Nu}_D k / D_h = 4.86 \times 0.0258 \text{ W/m}\cdot\text{K} / 0.01 \text{ m} = 12.5 \text{ W/m}^2\cdot\text{K}$ .  $T_{m,o} = T_s - (T_s - T_{m,i}) \exp(-L \bar{h} / (\dot{m}/w) c_p) = 65^\circ\text{C} - 45^\circ\text{C} \exp(-0.15 \text{ m} \times 12.5 \text{ W/m}^2\cdot\text{K} / 0.00907 \text{ kg/s}\cdot\text{m} \times 1007 \text{ J/kg}\cdot\text{K}) = 28.4^\circ\text{C}$ .

From Eq. (1)

$$q' = \frac{\dot{m}}{w} c_p (T_{m,o} - T_{m,i}) = 0.00907 \text{ kg/m}\cdot\text{s} \times 1007 \text{ J/kg}\cdot\text{K} \times (28.4 - 20)^\circ\text{C} = 76.5 \text{ W/m} \quad <$$
$$q'' = q'/L = 510 \text{ W/m}^2$$

**COMMENTS:** (1) The thermophysical properties of the air are evaluated at the average mean temperature,  $\bar{T}_m = (T_{m,i} + T_{m,o})/2$ .

(2) The fully developed flow length,  $x_{fd,t}$ , for the channel follows from Eq. 8.23,

$$x_{fd,t} = D_h \times 0.05 Re_{D_h} Pr$$
$$x_{fd,t} = 2 \times 0.010 \text{ m} \times 0.05 \times 7954 \times 0.709 = 5.6 \text{ m}$$

Since  $L \ll x_{fd,t}$ , we conclude that the flow is not likely to be fully developed.

### PROBLEM 8.93

**KNOWN:** Surface thermal conditions and diameters associated with a concentric tube annulus. Water flow rate and inlet temperature.

**FIND:** (a) Length required to achieve desired outlet temperature, (b) Heat flux from inner tube at outlet.

**SCHEMATIC:**

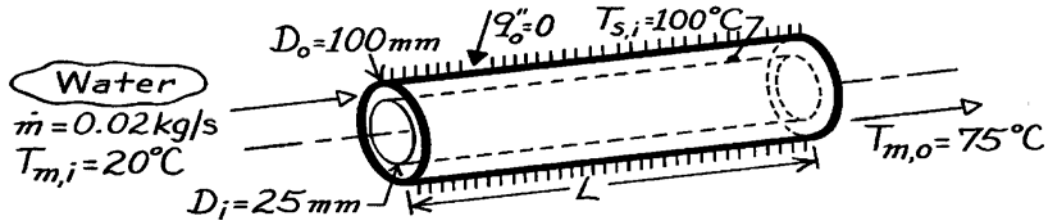

**ASSUMPTIONS:** (1) Steady-state conditions, (2) Fully developed conditions throughout, (3) Adiabatic outer surface, (4) Uniform temperature at inner surface, (5) Constant properties, (6) Water is incompressible liquid with negligible viscous dissipation.

**PROPERTIES:** Table A-6, Water ( $\bar{T}_m = 320\text{K}$ ):  $c_p = 4180\text{ J/kg}\cdot\text{K}$ ,  $\mu = 577 \times 10^{-6}\text{ N}\cdot\text{s/m}^2$ ,  $k = 0.640\text{ W/m}\cdot\text{K}$ ,  $Pr = 3.77$ .

**ANALYSIS:** (a) From Eq. 8.41a,

$$L = -\frac{\dot{m} c_p}{Ph} \ln \frac{\Delta T_o}{\Delta T_i} = -\frac{\dot{m} c_p}{\pi D_i \bar{h}} \ln \frac{T_s - T_{m,o}}{T_s - T_{m,i}}$$

$$\text{With } Re_D = \frac{\rho u_m D_h}{\mu} = \frac{\dot{m} (D_o - D_i)}{(\pi/4) (D_o^2 - D_i^2) \mu} = \frac{4 \dot{m}}{\pi (D_o + D_i) \mu}$$

$$Re_D = \frac{4 \times 0.02\text{ kg/s}}{\pi (0.125\text{ m}) 577 \times 10^{-6}\text{ N}\cdot\text{s/m}^2} = 353$$

the flow is laminar. Hence, from Eq. 8.69 and Table 8.2,

$$\bar{h} = h_i = \frac{k}{D_h} Nu_i = \frac{0.64\text{ W/m}\cdot\text{K}}{(0.100 - 0.025)\text{ m}} 7.37 = 63\text{ W/m}^2\cdot\text{K}$$

$$\text{and } L = -\frac{0.02\text{ kg/s} (4180\text{ J/kg}\cdot\text{K})}{\pi (0.025\text{ m}) 63\text{ W/m}^2\cdot\text{K}} \ln \frac{(100 - 75)^\circ\text{C}}{(100 - 20)^\circ\text{C}} = 19.7\text{ m.} \quad <$$

(b) From Eq. 8.67

$$q_i''(L) = h_i (T_{s,i} - T_{m,o}) = 63 \frac{\text{W}}{\text{m}^2\cdot\text{K}} (100 - 75)^\circ\text{C} = 1575\text{ W/m}^2. \quad <$$

**COMMENTS:** The total heat rate to the water is

$$q = \dot{m} c_p (T_{m,o} - T_{m,i}) = 0.02\text{ kg/s} \times 4180\text{ J/kg}\cdot\text{K} (55^\circ\text{C}) = 4598\text{ W.}$$

### PROBLEM 8.94

**KNOWN:** Surface thermal conditions and diameters associated with a concentric tube annulus. Water flow rate and inlet temperature.

**FIND:** Length required to achieve desired outlet temperature.

**SCHEMATIC:**

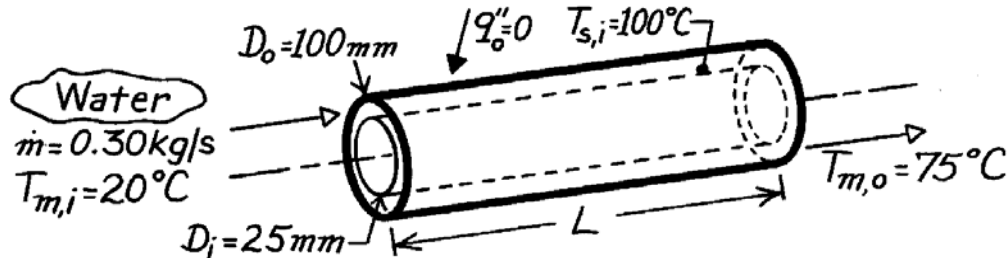

**ASSUMPTIONS:** (1) Steady-state conditions, (2) Fully developed conditions throughout, (3) Adiabatic outer surface, (4) Uniform temperature at inner surface, (5) Constant properties, (6) Incompressible liquid with negligible viscous dissipation.

**PROPERTIES:** Table A-6, Water ( $\bar{T}_m = 320\text{K}$ ):  $c_p = 4180\text{ J/kg}\cdot\text{K}$ ,  $\mu = 577 \times 10^{-6}\text{ N}\cdot\text{s/m}^2$ ,  $k = 0.640\text{ W/m}\cdot\text{K}$ ,  $\text{Pr} = 3.77$ .

**ANALYSIS:** From Eq. 8.41a,

$$L = -\frac{\dot{m} c_p}{P \bar{h}} \ln \frac{\Delta T_o}{\Delta T_i} = -\frac{\dot{m} c_p}{\pi D_i \bar{h}} \ln \frac{T_s - T_{m,o}}{T_s - T_{m,i}}$$

With

$$\text{Re}_D = \frac{\rho u_m D_h}{\mu} = \frac{\dot{m} (D_o - D_i)}{(\pi/4) (D_o^2 - D_i^2) \mu} = \frac{4 \dot{m}}{\pi (D_o + D_i) \mu}$$

$$\text{Re}_D = \frac{4 \times 0.30\text{ kg/s}}{\pi (0.125\text{ m}) 577 \times 10^{-6}\text{ N}\cdot\text{s/m}^2} = 5296$$

and the flow is turbulent. Hence, from Eq. 8.60,

$$\bar{h} = \frac{k}{D_h} \text{Nu}_D = 0.023 \frac{k}{D_h} \text{Re}_D^{4/5} \text{Pr}^{0.4}$$

$$\bar{h} = 0.023 \frac{0.640\text{ W/m}\cdot\text{K}}{0.075\text{ m}} (5296)^{4/5} (3.77)^{0.4} = 318\text{ W/m}^2\cdot\text{K}$$

and hence the required length is

$$L = -\frac{0.30\text{ kg/s} (4180\text{ J/kg}\cdot\text{K})}{\pi (0.025\text{ m}) 318\text{ W/m}^2\cdot\text{K}} \ln \frac{(100 - 75)^\circ\text{C}}{(100 - 20)^\circ\text{C}} = 58.4\text{ m.} \quad <$$

**COMMENTS:** (1) Increasing  $\dot{m}$  by a factor of 15 increases  $\text{Re}_D$  accordingly, and the flow is turbulent. However,  $\bar{h}$  increases by a factor of only 5 from the result of Problem 8.93, in which case the tube length must be a factor of 3 larger than that of Problem 8.93. (2) The Gnielinski correlation would be more accurate than the Dittus-Boelter correlation for the low (but turbulent) conditions suggested by the value of the Reynolds number.

### PROBLEM 8.95

**KNOWN:** Inner and outer tube surface conditions for an annulus.

**FIND:** (a) Velocity profile, (b) Temperature profile and expression for inner surface Nusselt number.

**SCHEMATIC:**

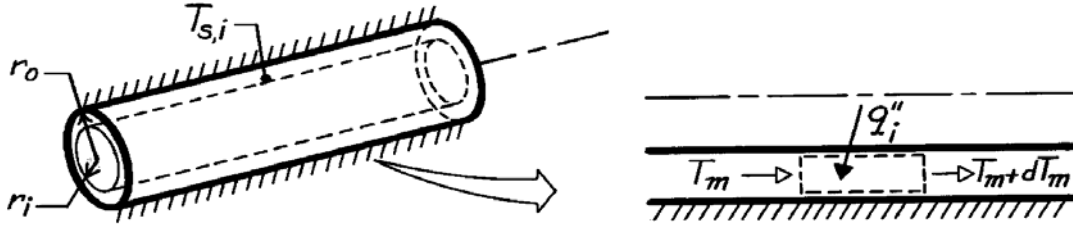

**ASSUMPTIONS:** (1) Steady-state conditions, (2) Laminar, fully developed flow, (3) Uniform heat flux at inner surface, (4) Adiabatic outer surface, (5) Constant properties, (6) Applicability of Eq. 8.34.

**ANALYSIS:** (a) From Section 8.1.3, the general solution to Eq. 8.12, which also applies to annular flow as represented in Figure 8.11, is

$$u(r) = \frac{1}{\mu} \left( \frac{dp}{dx} \right) \frac{r^2}{4} + C_1 \ln r + C_2.$$

Applying the boundary conditions,

$$u(r_i) = 0 \quad 0 = \frac{1}{\mu} \left( \frac{dp}{dx} \right) \frac{r_i^2}{4} + C_1 \ln r_i + C_2$$

$$u(r_o) = 0 \quad 0 = \frac{1}{\mu} \left( \frac{dp}{dx} \right) \frac{r_o^2}{4} + C_1 \ln r_o + C_2.$$

Hence,

$$C_1 = \frac{\frac{1}{\mu} \left( \frac{dp}{dx} \right) \left( \frac{r_o^2}{4} - \frac{r_i^2}{4} \right)}{\ln r_i / r_o} \quad C_2 = -\frac{1}{\mu} \left( \frac{dp}{dx} \right) \frac{r_o^2}{4} - \frac{1}{\mu} \left( \frac{dp}{dx} \right) \left( \frac{r_o^2}{4} - \frac{r_i^2}{4} \right) \frac{\ln r_o}{\ln (r_i / r_o)}$$

and the velocity distribution is

$$u(r) = \frac{1}{\mu} \left( \frac{dp}{dx} \right) \left( \frac{r^2}{4} - \frac{r_o^2}{4} \right) + \frac{1}{\mu} \left( \frac{dp}{dx} \right) \left( \frac{r_o^2}{4} - \frac{r_i^2}{4} \right) \frac{\ln r}{\ln (r_i / r_o)} - \frac{1}{\mu} \left( \frac{dp}{dx} \right) \left( \frac{r_o^2}{4} - \frac{r_i^2}{4} \right) \frac{\ln r_o}{\ln (r_i / r_o)}$$

$$u(r) = -\frac{r_o^2}{4\mu} \left( \frac{dp}{dx} \right) \left[ 1 - (r/r_o)^2 + \frac{(r_i/r_o)^2 - 1}{\ln (r_i / r_o)} \ln (r/r_o) \right]. \quad (1) <$$

(b) For fully developed conditions with uniform surface heat flux,

$$v = 0 \quad \partial T / \partial x = dT_m / dx = \text{const.}$$

Continued ...

**PROBLEM 8.95 (Cont.)**

Hence, from Eq. 8.48, which also applies for annular flow,

$$\frac{1}{r} \frac{\partial}{\partial r} \left( r \frac{\partial T}{\partial r} \right) = \frac{u}{\alpha} \frac{dT_m}{dx}$$

Substituting the velocity distribution, with

$$C_1 = -\frac{r_0^2}{4\mu} \left( \frac{dp}{dx} \right) \quad C_2 = \frac{(r_1/r_0)^2 - 1}{\ln(r_1/r_0)} \quad (2)$$

it follows that  $\frac{1}{r} \frac{\partial}{\partial r} \left( r \frac{\partial T}{\partial r} \right) = \frac{C_1}{\alpha} \frac{dT_m}{dx} \left[ 1 - (r/r_0)^2 + C_2 \ln(r/r_0) \right]$ .

$$r \frac{\partial T}{\partial r} = \frac{C_1}{\alpha} \frac{dT_m}{dx} \int \left[ r - \frac{r^3}{r_0^2} + C_2 r \ln \frac{r}{r_0} \right] dr + C_3$$

$$\frac{\partial T}{\partial r} = \frac{C_1}{\alpha} \frac{dT_m}{dx} \left[ \frac{r}{2} - \frac{r^3}{4r_0^2} + C_2 \left( \frac{r}{2} \ln \frac{r}{r_0} - \frac{r}{4} \right) \right] + \frac{C_3}{r}$$

and the temperature distribution is

$$T(r) = \frac{C_1}{\alpha} \frac{dT_m}{dx} \left[ \frac{r^2}{4} - \frac{r^4}{16r_0^2} + C_2 \left( \frac{r^2}{4} \ln \frac{r}{r_0} - \frac{r^2}{4} \right) \right] + C_3 \ln r + C_4. \quad (3) <$$

From the requirement that  $q_0'' = 0$ , it follows that  $\partial T / \partial r|_{r_0} = 0$ . Hence,

$$\frac{C_1}{\alpha} \frac{dT_m}{dx} \left[ \frac{r_0}{2} - \frac{r_0}{4} + C_2 \left( -\frac{r_0}{4} \right) \right] + \frac{C_3}{r_0} = 0$$

$$C_3 = \frac{C_1}{\alpha} \frac{dT_m}{dx} \frac{r_0^2}{4} (C_2 - 1). \quad (4) <$$

From the condition that  $T(r_1) = T_{s,i}$ , it follows that

$$C_4 = T_{s,i} - \frac{C_1}{\alpha} \frac{dT_m}{dx} \left[ \frac{r_1^2}{4} - \frac{r_1^4}{16r_0^2} + C_2 \left( \frac{r_1^2}{4} \ln \frac{r_1}{r_0} - \frac{r_1^2}{4} \right) \right] + C_3 \ln r_1. \quad (5) <$$

From Eqs. 8.67 and 8.69, the inner surface Nusselt number is

$$Nu_i = \frac{h_i D_h}{k} = \frac{q_i'' D_h}{k(T_{s,i} - T_m)}$$

where  $D_h = 2(r_0 - r_1)$ . To obtain a workable form of  $Nu_i$ , the mean temperature  $T_m$  must be evaluated.

This may be done by substituting Eqs. (1) and (3) into Eq. 8.26 and evaluating  $u_m$  by substituting Eq. (1) into Eq. 8.8. Since the integrations are long and tedious, they are not provided.

**COMMENTS:** From an energy balance performed for a differential control volume in the annular region,  $dT_m/dx = 2r_1 q_i'' / \rho c_p u_m (r_0^2 - r_1^2)$ .



## PROBLEM 8.96

**KNOWN:** Inlet temperature, pressure and flow rate of air. Annulus length and tube diameters. Pressure of saturated steam.

**FIND:** Outlet temperature and pressure drop of air. Mass rate of steam condensation.

**SCHEMATIC:**

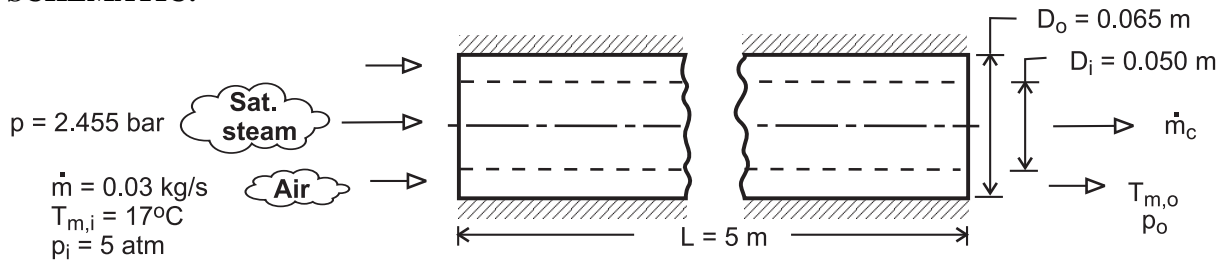

**ASSUMPTIONS:** (1) Steady-state, (2) Outer surface of annulus is adiabatic, (3) Air is ideal gas with negligible viscous dissipation and pressure variation, (4) Fully developed flow throughout annulus, (5) Smooth annulus surfaces, (6) Constant properties.

**PROPERTIES:** Table A-4, air ( $\bar{T}_m \approx 325$  K,  $p = 5$  atm):  $\rho = 5 \times \rho(1 \text{ atm}) = 5.391 \text{ kg/m}^3$ ,  $c_p = 1008 \text{ J/kg}\cdot\text{K}$ ,  $\mu = 196.4 \times 10^{-7} \text{ N}\cdot\text{s/m}^2$ ,  $k = 0.0281 \text{ W/m}\cdot\text{K}$ ,  $Pr = 0.703$ . Table A-6, sat. steam ( $p = 2.455$  bars):  $T_s = 400$  K,  $h_{fg} = 2183 \text{ kJ/kg}$ .

**ANALYSIS:** With a uniform surface temperature, the air outlet temperature is

$$T_{m,o} = T_s - (T_s - T_{m,i}) \exp\left(-\frac{\pi D_i L \bar{h}}{\dot{m} c_p}\right)$$

With  $A_c = \pi(D_o^2 - D_i^2)/4 = 1.355 \times 10^{-3} \text{ m}^2$ ,  $D_h = D_o - D_i = 0.015 \text{ m}$  and  $Re_D = \rho u_m D_h / \mu = \dot{m} D_h / A_c \mu = 16,900$ , the flow is turbulent and the Dittus-Boelter correlation yields

$$\bar{h} \approx h_{fd} = \left(\frac{k}{D_h}\right) 0.023 Re_D^{4/5} Pr^{0.4} = \left(\frac{0.0281 \text{ W/m}\cdot\text{K}}{0.015 \text{ m}}\right) 0.023 (16,900)^{4/5} (0.703)^{0.4} = 90.3 \text{ W/m}^2 \cdot \text{K}$$

$$T_{m,o} = 127^\circ\text{C} - (110^\circ\text{C}) \exp\left(-\frac{\pi \times 0.05 \text{ m} \times 5 \text{ m} \times 90.3 \text{ W/m}^2 \cdot \text{K}}{0.03 \text{ kg/s} \times 1008 \text{ J/kg}\cdot\text{K}}\right) = 116.5^\circ\text{C} <$$

The pressure drop is  $\Delta p = f \left(\rho u_m^2 / 2D_h\right) L$ , where, with  $u_m = \dot{m} / \rho A_c = 0.03 \text{ kg/s} /$

$\left(5.391 \text{ kg/m}^3 \times 1.355 \times 10^{-3} \text{ m}^2\right) = 4.11 \text{ m/s}$ , and with  $Re_D = 16,900$ , Eq. 8.21 yields  $f = [0.790 \ln(Re_D) - 1.64]^{-2} = 0.027$ . Hence,

$$\Delta p \approx 0.027 \times 5.391 \text{ kg/m}^3 \frac{(4.11 \text{ m/s})^2 5 \text{ m}}{2 \times 0.015 \text{ m}} = 415 \text{ N/m}^2 = 4.1 \times 10^{-3} \text{ atm} <$$

The rate of heat transfer to the air is

$$q = \dot{m} c_p (T_{m,o} - T_{m,i}) = 0.03 \text{ kg/s} \times 1008 \text{ J/kg}\cdot\text{K} (99.5^\circ\text{C}) = 3009 \text{ W}$$

and the rate of condensation is then

$$\dot{m}_c = \frac{q}{h_{fg}} = \frac{3009 \text{ W}}{2.183 \times 10^6 \text{ J/kg}} = 1.38 \times 10^{-3} \text{ kg/s} <$$

**COMMENTS:** (1) With  $\bar{T}_m = (T_{m,i} + T_{m,o}) / 2 = 340$  K, the initial estimate of 325 K is too low and an iterative solution should be obtained, (2) For a steam flow rate of 0.01 kg/s, approximately 14% of the outflow would be in the form of saturated liquid, (3) With  $L/D_h = 333$ , the assumption of fully developed flow throughout the tube is excellent.

### PROBLEM 8.97

**KNOWN:** Dimensions and surface thermal conditions for a concentric tube annulus. Water flow rate and inlet temperature.

**FIND:** (a) Tube length required to achieve desired outlet temperature, (b) Inner tube surface temperature at outlet.

**SCHEMATIC:**

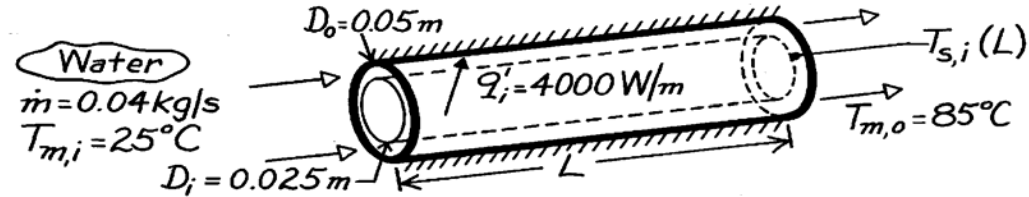

**ASSUMPTIONS:** (1) Steady-state conditions, (2) Uniform heat flux at inner surface, (3) Adiabatic outer surface, (4) Fully developed flow at exit, (5) Constant properties, (6) Incompressible liquid with negligible viscous dissipation.

**PROPERTIES:** Table A-6, Water ( $\bar{T}_m = 328\text{K}$ ):  $c_p = 4183 \text{ J/kg}\cdot\text{K}$ ; ( $T_{m,o} = 358\text{K}$ ):  $\mu = 332 \times 10^{-6} \text{ N}\cdot\text{s/m}^2$ ,  $k = 0.673 \text{ W/m}\cdot\text{K}$ ,  $Pr = 2.07$ .

**ANALYSIS:** (a) From the overall energy balance, Eq. 8.34,

$$q = q_i' L = \dot{m} c_p (T_{m,o} - T_{m,i})$$

$$L = \frac{\dot{m} c_p (T_{m,o} - T_{m,i})}{q_i'} = \frac{(0.04 \text{ kg/s}) 4183 \text{ J/kg}\cdot\text{K} (85 - 25)^\circ\text{C}}{4000 \text{ W/m}} = 2.51 \text{ m.} \quad <$$

(b) From Eqs. 8.1 and 8.5,

$$Re_D = \frac{\rho u_m D_h}{\mu} = \frac{\dot{m} D_h}{A_c \mu} = \frac{\dot{m} (D_o - D_i)}{(\pi/4) (D_o^2 - D_i^2) \mu} = \frac{4 \dot{m}}{\pi (D_o + D_i) \mu}$$

$$Re_D = \frac{4 \times 0.04 \text{ kg/s}}{\pi (0.075 \text{ m}) 332 \times 10^{-6} \text{ kg/s}\cdot\text{m}} = 2045.$$

Hence the flow is laminar, and with  $D_i/D_o = 0.5$ , it follows from Eq. 8.72 and Table 8.3

$$Nu_i = Nu_{ij} = 6.24$$

$$h_i = 6.24 \frac{k}{D_h} = 6.24 \frac{0.673 \text{ W/m}\cdot\text{K}}{0.025 \text{ m}} = 168 \text{ W/m}^2 \cdot \text{K}.$$

From Eq. 8.67,

$$T_{s,i}(L) = T_{m,o} + \frac{q_i'}{h_i} = T_{m,o} + \frac{q_i' / \pi D_i}{h_i}$$

$$T_{s,i}(L) = 85^\circ\text{C} + \frac{4000 \text{ W/m}}{\pi (0.025 \text{ m}) 168 \text{ W/m}^2 \cdot \text{K}} = 388^\circ\text{C.} \quad <$$

**COMMENTS:** Unless the water is pressurized, local boiling would occur at the tube surface, causing  $h_i$  to be larger.

### PROBLEM 8.98

**KNOWN:** Heat rate per unit length at the inner surface of an annular recuperator of prescribed dimensions. Flow rate and inlet temperature of air passing through annular region.

**FIND:** (a) Temperature of air leaving the recuperator, (b) Inner pipe temperature at inlet and outlet and outer pipe temperature at inlet.

**SCHEMATIC:**

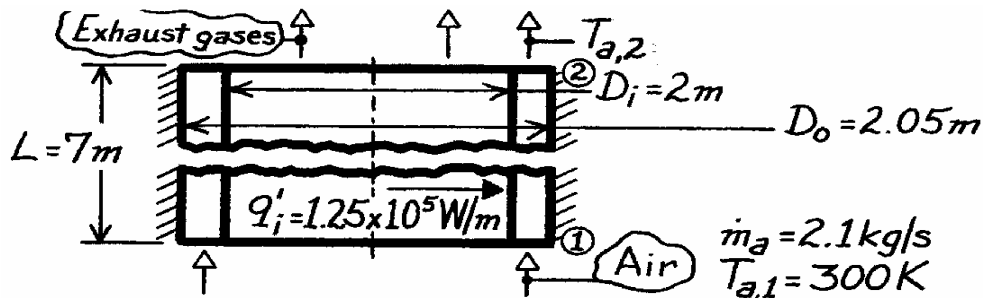

**ASSUMPTIONS:** (1) Steady-state conditions, (2) Constant properties, (3) Uniform heating of recuperator inner surface, (4) Adiabatic outer surface, (5) Air is ideal gas with negligible viscous dissipation and pressure variation, (6) Fully developed air flow throughout.

**PROPERTIES:** Table A-4, Air (given):  $c_p = 1030 \text{ J/kg}\cdot\text{K}$ ,  $\mu = 270 \times 10^{-7} \text{ N}\cdot\text{s/m}^2$ ,  $k = 0.041 \text{ W/m}\cdot\text{K}$ ,  $Pr = 0.68$ .

**ANALYSIS:** (a) From an energy balance on the air

$$q'_i L = \dot{m}_a c_{p,a} (T_{a,2} - T_{a,1})$$

$$T_{a,2} = T_{a,1} + \frac{q'_i L}{\dot{m}_a c_{p,a}} = 300 \text{ K} + \frac{1.25 \times 10^5 \text{ W/m} \times 7 \text{ m}}{2.1 \text{ kg/s} \times 1030 \text{ J/kg}\cdot\text{K}} = 704.5 \text{ K.} \quad <$$

(b) The surface temperatures may be evaluated from Eqs. 8.67 and 8.68 with

$$Re_D = \frac{\rho u_m D_h}{\mu} = \frac{\dot{m}_a (D_o - D_i)}{(\pi/4) (D_o^2 - D_i^2) \mu} = \frac{4 \dot{m}_a}{\pi (D_o + D_i) \mu} = \frac{4(2.1 \text{ kg/s})}{\pi(4.05 \text{ m}) 270 \times 10^{-7} \text{ N}\cdot\text{s/m}^2}$$

$$Re_D = 24,452$$

the flow is turbulent and from Eq. 8.60

$$h_i \approx h_o \approx \frac{k}{D_h} 0.023 Re_D^{4/5} Pr^{0.4} = \frac{0.041 \text{ W/m}\cdot\text{K}}{0.05 \text{ m}} 0.023 (24,452)^{4/5} (0.68)^{0.4} = 52 \text{ W/m}^2 \cdot \text{K.}$$

$$\text{With } q''_i = q'_i / \pi D_i = 1.25 \times 10^5 \text{ W/m} / \pi \times 2 \text{ m} = 19,900 \text{ W/m}^2$$

Eq. 8.67 gives

$$(T_{s,i} - T_m) = q''_i / h_i = 19,900 \text{ W/m}^2 / 52 \text{ W/m}^2 \cdot \text{K} = 383 \text{ K}$$

$$T_{s,i,1} = 683 \text{ K} \quad T_{s,i,2} = 1087 \text{ K.} \quad <$$

From Eq. 8.68, with  $q''_o = 0$ ,  $(T_{s,o} - T_m) = 0$ . Hence

$$T_{s,o,1} = T_{a,1} = 300 \text{ K.} \quad <$$

## PROBLEM 8.99

**KNOWN:** A concentric tube arrangement for removing heat generated from a biochemical reaction in a settling tank. Water is supplied to the annular region at rate of 0.2 kg/s.

**FIND:** (a) The inlet temperature of the supply water that will provide for an average tank surface temperature of 37°C; assume and then justify fully developed flow and thermal conditions; and (b) Sketch the water and surface temperatures along the flow direction for two cases: the fully developed conditions of part (a), and when entrance effects are important. Comment on the features of the temperature distributions, with particular attention to the longitudinal gradient on the tank surface. What change to the system or operating conditions would you make to reduce the gradient?

**SCHEMATIC:**

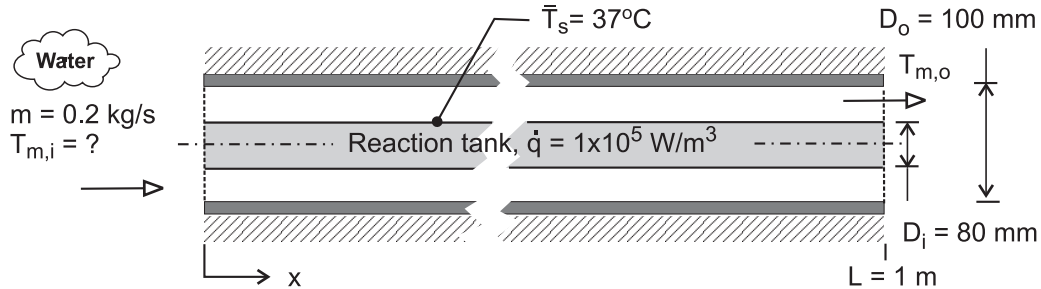

**ASSUMPTIONS:** (1) Fully developed flow and thermal conditions, (2) Inner annulus surface has uniform heat flux, while outer surface is insulated, (3) Constant properties, (4) Incompressible liquid with negligible viscous dissipation.

**PROPERTIES:** Table A-6, Water ( $T_m = 304$  K):  $\rho = 995.6$  kg/m<sup>3</sup>,  $c_p = 4178$  J/kg·K,  $\nu = 7.987 \times 10^{-7}$  m<sup>2</sup>/s,  $k = 0.618$  W/m·K,  $Pr = 5.39$ .

**ANALYSIS:** (a) The overall energy balance on the fluid passing through the concentric tube is

$$q = \dot{m} c_p (T_{m,i} - T_{m,o}) \quad (1)$$

and from an energy balance on the reaction tank,

$$q = \dot{q} (\pi D_i^2 / 4) / L = 1 \times 10^5 \text{ W/m}^3 (\pi (0.08 \text{ m})^2 / 4) \times 1 \text{ m} = 503 \text{ W}. \quad (2)$$

The convection rate equation applied to the inner surface  $A_{s,i}$  is

$$q = \bar{h}_i A_{s,i} (\bar{T}_s - \bar{T}_m) = \bar{h}_i \pi D_i L (\bar{T}_s - \bar{T}_m) \quad (3)$$

where  $\bar{T}_s$  is the average inner surface temperature and

$$\bar{T}_m = (T_{m,i} + T_{m,o}) / 2. \quad (4)$$

To estimate  $\bar{h}$ , begin by characterizing the flow with

$$Re_{Dh} = u_m D_h / \nu \quad D_h = D_o - D_i \quad \dot{m} = \rho A_c u_m$$

where  $A_c = \pi (D_o^2 - D_i^2) / 4$ . Substituting numerical values find

$$Re_{Dh} = 1779$$

Assuming fully developed conditions for laminar flow through an annulus, it follows from Table 8.3 and Eq. 8.72 with  $D_i/D_o = 0.8$ ,

$$\bar{Nu}_i = \bar{h}_i D_h / k = 5.58 \quad \bar{h}_i = 172 \text{ W/m}^2 \cdot \text{K}$$

Continued ...

### PROBLEM 8.99 (Cont.)

Using Eq. (3) with  $\bar{h}_i$ , and  $\bar{T}_s = 37^\circ\text{C}$ , and  $q$  from Eq. (2), find

$$\bar{T}_m = 25.4^\circ\text{C}$$

From Eqs. (1) and (4), calculate

$$T_{m,i} = 25.1^\circ\text{C} \quad T_{m,o} = 25.7^\circ\text{C}$$

<

For this annulus, the thermal entry length from Eq. 8.23 is

$$x_{fd,t} = D_h \times 0.05 \text{ Re}_{Dh} \text{ Pr}$$

$$x_{fd,t} = (0.100 - 0.080) \text{ m} \times 0.05 \times 1779 \times 5.39 = 9.59 \text{ m}$$

Since  $L = 1 \text{ m}$ , we conclude that entry length effects are significant, and the fully developed flow assumption is approximate.

(b) Since the fluid is being heated by flow over a surface with uniform heat flux, the mean fluid temperature,  $T_m(x)$ , will increase linearly with longitudinal distance  $x$ . Assuming fully developed conditions, the surface temperature  $T_s(x)$  will likewise increase linearly with distance as shown in the schematic below. Note that the longitudinal temperature difference is about  $0.6^\circ\text{C}$ , and that the inlet mean temperature is  $25.1^\circ\text{C}$ .

Considering now entrance length effects, the convection coefficient is no longer uniform, and will be largest near the entrance, and larger than for the fully developed flow everywhere. Hence, we expect the surface temperature near the entrance to be closer to the mean fluid temperature than elsewhere. We also expect the average mean temperature of the fluid will be higher so that the average surface temperature,  $\bar{T}_s$ , remains at  $37^\circ\text{C}$ . However, the rise in temperature of the fluid ( $T_{m,o} - T_{m,i}$ ) will remain the same, about  $0.6^\circ\text{C}$ , since the heat removal rate is the same. Increasing the flow rate will tend to minimize the longitudinal gradient by reducing ( $T_{m,o} - T_{m,i}$ ) and increasing  $h(x)$ . The graph below illustrates the distinctive features of the fully developed flow and entrance length effects.

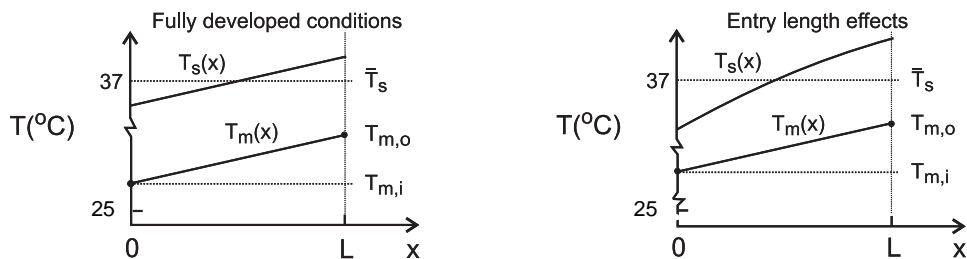

**COMMENTS:** The thermophysical properties required in the convection correlation and the energy equations should be evaluated at  $T_m = (T_{m,i} + T_{m,o})/2 \approx 298 \text{ K}$ .

## PROBLEM 8.100

**KNOWN:** Dimensions and thermal conductivity of plastic pipe. Volumetric flow rate and temperature of inlet air. Enhancement of inner convection coefficient and friction factor associated with coiled spring. Thermal resistance of coating on outer surface.

**FIND:** (a) Air outlet temperature and fan power requirement without coating and coiled spring, (b) Effect of coiled spring on air outlet temperature and fan power, (c) Effect of coating on outlet temperature.

**SCHEMATIC:**

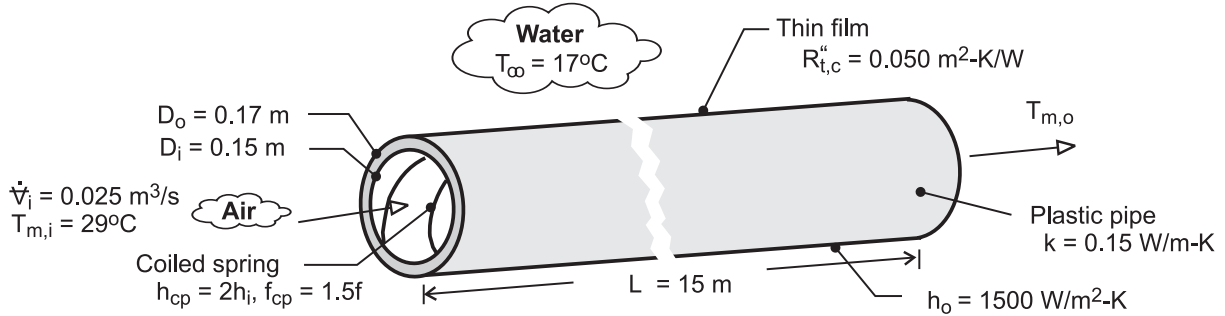

**ASSUMPTIONS:** (1) Steady-state, (2) Negligible heat transfer from air in vertical pipe sections, (3) Air is ideal gas with negligible viscous dissipation and pressure variation, (4) Smooth interior surface without spring, (5) Negligible coating thickness, (6) Constant properties.

**PROPERTIES:** Table A-4, Air ( $T_{m,i} = 29^\circ\text{C}$ ):  $\rho_1 = 1.155 \text{ kg/m}^3$ . Air ( $\bar{T}_m \approx 25^\circ\text{C}$ ):  $c_p = 1007 \text{ J/kg}\cdot\text{K}$ ,  $\mu = 183.6 \times 10^{-7} \text{ N}\cdot\text{s/m}^2$ ,  $k_a = 0.0261 \text{ W/m}\cdot\text{K}$ ,  $\text{Pr} = 0.707$ .

**ANALYSIS:** (a) From Eq. (8.45a),

$$\frac{T_\infty - T_{m,o}}{T_\infty - T_{m,i}} = \exp\left(-\frac{\bar{U}A_s}{\dot{m}c_p}\right)$$

where, from Eqs. (3.36) and (3.37),

$$(\bar{U}A_s)^{-1} = R_{\text{tot}} = \frac{1}{h_i\pi D_i L} + \frac{\ln(D_o/D_i)}{2\pi Lk} + \frac{1}{h_o\pi D_o L}$$

With  $\dot{m} = \rho_1 \dot{V}_1 = 0.0289 \text{ kg/s}$  and  $\text{Re}_D = 4\dot{m}/\pi D_i \mu = 13,350$ , the pipe flow is turbulent. With  $L/D_i = 100$ , we may assume fully developed flow throughout the pipe, and from Eq. (8.60),

$$\bar{h}_i = \frac{k_a}{D_i} 0.023 \text{Re}_D^{4/5} \text{Pr}^{0.3} = \frac{0.0261 \text{ W/m}\cdot\text{K}}{0.15\text{m}} 0.023(13,350)^{4/5} (0.707)^{0.3} = 7.20 \text{ W/m}^2\cdot\text{K}$$

$$\text{Hence, } R_{\text{tot}} = \left( \frac{1}{7.20 \times \pi \times 0.15 \times 15} + \frac{\ln(0.17/0.15)}{2\pi \times 15 \times 0.15} + \frac{1}{1500 \times \pi \times 0.17 \times 15} \right) \frac{\text{K}}{\text{W}}$$

$$R_{\text{tot}} = (0.0196 + 0.0089 + 0.0001) \text{ K/W} = 0.0286 \text{ K/W}$$

Hence,  $\bar{U}A_s = R_{\text{tot}}^{-1} = 35.0 \text{ W/K}$  and

$$T_{m,o} = T_\infty + (T_{m,i} - T_\infty) \exp\left(-\frac{\bar{U}A_s}{\dot{m}c_p}\right) = 17^\circ\text{C} + (12^\circ\text{C}) \exp\left(-\frac{35.0 \text{ W/K}}{0.0289 \text{ kg/s} \times 1007 \text{ J/kg}\cdot\text{K}}\right) = 20.6^\circ\text{C} <$$

Continued ...

### PROBLEM 8.100 (Cont.)

From Eq. (8.21),  $f = [0.790 \ln(Re_D) - 1.64]^{-2} = 0.0291$ . Hence, from Eqs. (8.22a) and (8.22b), with  $u_{m,i} = \dot{V}_i / A_c = 1.415 \text{ m/s}$ ,

$$P \approx f \frac{\rho_i u_{m,i}^2}{2D_i} L \dot{V}_i = 0.0291 \frac{1.155 \text{ kg/m}^3 (1.415 \text{ m/s})^2}{2(0.15 \text{ m})} 15 \text{ m} \times 0.025 \text{ m}^3/\text{s} = 0.084 \text{ W} \quad <$$

(b) With  $h_{cp} = 2h_i = 14.4 \text{ W/m}^2 \cdot \text{K}$ , the inner convection resistance is reduced from  $0.0196 \text{ K/W}$  to  $0.0098 \text{ K/W}$  and hence the total resistance from  $0.0286 \text{ K/W}$  to  $0.0188 \text{ K/W}$ . It follows that  $\bar{U}A_s = 53.2 \text{ W/K}$  and

$$T_{m,o} = 18.9^\circ\text{C} \quad <$$

With  $f_{cp} = 1.5f$ ,

$$P = 0.126 \text{ W} \quad <$$

(c) With the coating of organic matter, there is an additional thermal resistance of the form  $R_{t,c} = R''_{t,c} / (\pi D_o L) = (0.05 \text{ m}^2 \cdot \text{K/W}) / (\pi \times 0.17 \text{ m} \times 15 \text{ m}) = 0.0062 \text{ K/W}$ . The total resistance is then  $R_{tot} = 0.0348 \text{ K/W}$  and  $\bar{U}A_s = 28.7 \text{ W/K}$ . Hence,

$$T_{m,o} = 21.5^\circ\text{C} \quad <$$

**COMMENTS:** (1) The fan power requirement is small, and the process is economical, with or without the coiled spring. (2) Heat transfer enhancement associated with the coiled spring is manifested by a 34% reduction in the total thermal resistance and a  $1.7^\circ\text{C}$  reduction in the outlet temperature. (3) *Fouling* of the outer surface increases the total resistance by 22% and the outlet temperature by  $0.9^\circ\text{C}$ . The penalty is not severe but could be ameliorated by periodic cleaning of the surface.

### PROBLEM 8.101

**KNOWN:** Inlet and desired outlet temperature of a pharmaceutical fluid flowing in a straight tube or coiled tube of known diameter. Inlet velocity and tube surface temperature.

**FIND:** (a) Length of straight tube needed to achieve the desired outlet temperature, (b) Length of coiled tube to achieve the desired outlet temperature, (c) Pressure drops associated with the straight and coiled tubes, (d) Steam condensation rate.

**SCHEMATIC:**

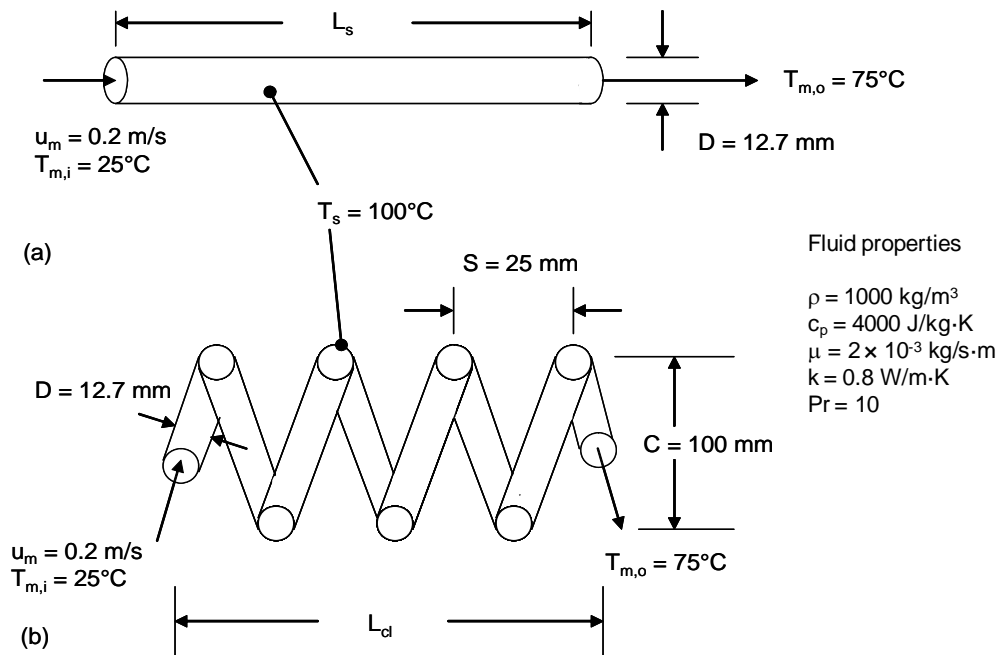

**ASSUMPTIONS:** (1) Constant properties, (2) Incompressible liquid and negligible viscous dissipation, (3) Steady-state conditions, (4) fully developed hydrodynamic conditions at the entrance.

**PROPERTIES:** Steam (Table A.6):  $h_{fg}(T = 100^\circ\text{C}) = 2257 \text{ kJ/kg}$ . Pharmaceutical (given):  $\rho = 1000 \text{ kg/m}^3$ ,  $c_p = 4000 \text{ J/kg}\cdot\text{K}$ ,  $\mu = 2 \times 10^{-3} \text{ kg/s}\cdot\text{m}$ ,  $k = 0.80 \text{ W/m}\cdot\text{K}$ ,  $Pr = 10$ .

**ANALYSIS:**

(a) From Problem 8.27,  $Re_D = \rho u_m D / \mu = 1270$  and the flow is laminar for both cases. Hence, augmentation is expected to occur in the coiled tube. For the straight tube case a, the Hausen correlation is written as

$$\overline{Nu}_D = \frac{\bar{h}D}{k} = 3.66 + \frac{0.0668 \times (D/L_s) Re_D Pr}{1 + 0.04 [(D/L_s) Re_D Pr]^{2/3}}$$

which may be rearranged to yield

Continued...



**PROBLEM 8.101 (Cont.)**

$$\bar{h} = \frac{k}{D} \left\{ 3.66 + \frac{0.0668 (D/L_s) \text{Re}_D \text{Pr}}{1 + 0.04 [(D/L_s) \text{Re}_D \text{Pr}]^{2/3}} \right\}$$

$$\bar{h} = \frac{0.80 \text{ W/mK}}{12.7 \times 10^{-3} \text{ m}} \left\{ 3.66 + \frac{0.0668(12.7 \times 10^{-3} \text{ m/L}_s) \times 1270 \times 10}{1 + 0.04 [(12.7 \times 10^{-3} \text{ m/L}_s) \times 1270 \times 10]^{2/3}} \right\} \quad (1)$$

From Problem 8.27  $\dot{m} = 0.0253 \text{ kg/s}$  and the tube perimeter is

$$P = \pi D = \pi \times 12.7 \times 10^{-3} \text{ m} = 39.9 \times 10^{-3} \text{ m}$$

Equation 8.41b may be written

$$\frac{100^\circ\text{C} - 75^\circ\text{C}}{100^\circ\text{C} - 25^\circ\text{C}} = \exp\left(-\frac{39.9 \times 10^{-3} \text{ m} \times L_s}{0.0253 \text{ kg/s} \times 4000 \text{ J/kg} \cdot \text{K}} \times \bar{h}\right) \quad (2)$$

Equations (1) and (2) may be solved simultaneously to yield

$$L_s = 9.77 \text{ m}, (\bar{h} = 286 \text{ W/m}^2 \cdot \text{K}) \quad <$$

(b) For the coiled tube,

$$\text{Re}_D(D/C)^{1/2} = 1270 \times (12.7/100)^{1/2} = 452.6$$

Therefore,  $C/D = 100/12.7 = 7.87 > 3$ , Equation 8.77 yields

$$a = \left(1 + \frac{957(C/D)}{\text{Re}_D^2 \text{Pr}}\right) = \left(1 + \frac{957 \times (100/12.7)}{1270^2 \times 10}\right) = 1.0005$$

$$b = 1 + \frac{0.477}{\text{Pr}} = 1 + \frac{0.477}{10} = 1.0477$$

Therefore Equation 8.76 becomes

$$\text{Nu}_D = \left[ \left(3.66 + \frac{4.343}{1.0005}\right)^3 + 1.158 \times \left(\frac{1270 \times (12.7/100)^{1/2}}{1.0477}\right)^{3/2} \right]^{1/3} = 22.18$$

Therefore,

$$h = \text{Nu}_D \frac{k}{D} = 22.18 \times \frac{0.80 \text{ W/m} \cdot \text{K}}{12.7 \times 10^{-3} \text{ m}} = 1397 \text{ W/m}^2 \cdot \text{K}$$

Equation 8.41b may be written

Continued...

**PROBLEM 8.101 (Cont.)**

$$\frac{100^\circ\text{C} - 75^\circ\text{C}}{100^\circ\text{C} - 25^\circ\text{C}} = \exp\left(-\frac{3.99 \times 10^{-3} \text{ m} \times L_c}{0.0253 \text{ kg/s} \times 4000 \text{ J/kg} \cdot \text{K}} \times 1397 \text{ W/m}^2 \cdot \text{K}\right)$$

or  $L_c = 2.00 \text{ m}$

The number of coil turns is  $N = \frac{L_c}{\pi C} = \frac{2.00 \text{ m}}{\pi \times 100 \times 10^{-3} \text{ m}} = 6.4$

The coil length is  $L_{cl} = NS = 6.4 \times 25 \times 10^{-3} \text{ m} = 159 \times 10^{-3} \text{ m} = 159 \text{ mm}$  <

(c) The flow is hydrodynamically fully-developed in the straight tube. From Equations 8.19 and 8.22a,

$$\Delta p_s = \frac{64}{\text{Re}_D} \frac{\rho u_m^2}{2D} L_s = \frac{64}{1270} \times \frac{1000 \text{ kg/m}^3 \times (0.2 \text{ m/s})^2}{2 \times 12.7 \times 10^{-3} \text{ m}} \times 9.77 \text{ m} = 775 \text{ N/m}^2$$
 <

For the coiled tube, Equation 8.75b is

$$f = \frac{7.2}{\text{Re}_D^{0.5}} (D/C)^{0.25} = \frac{7.2}{1270^{0.5}} \times \left(\frac{12.7}{100}\right)^{0.25} = 0.121$$

$$\Delta p_c = f \frac{\rho u_m^2}{2D} L_c = 0.121 \times \frac{1000 \text{ kg/m}^3 \times (0.2 \text{ m/s})^2}{2 \times 12.7 \times 10^{-3} \text{ m}} \times 2.00 \text{ m} = 379 \text{ N/m}^2$$
 <

(d) The steam condensation rate,  $\dot{m}_{st}$ , is

$$\dot{m}_{st} h_{fg} = \dot{m} c_p (T_{m,o} - T_{m,i}) = u_m \rho A c_p (T_{m,o} - T_{m,i})$$

or

$$\dot{m}_{st} = \frac{0.2 \text{ m/s} \times 1000 \text{ kg/m}^3 \times \pi \times (12.7 \times 10^{-3} \text{ m})^2 \times 4000 \text{ J/kg} \cdot \text{K} \times (75 - 25)^\circ\text{C}}{4 \times 2257 \times 10^3 \text{ J/kg}}$$

$$\dot{m}_{st} = 2.25 \times 10^{-3} \text{ kg/s}$$
 <

**COMMENTS:** (1) For the straight tube,  $x_{fd,t} = 0.05 \text{Re}_D \text{Pr} D = 0.05 \times 1270 \times 10 \times 12.7 \times 10^{-3} \text{ m} = 8 \text{ m}$ . The value of the entrance length for the coiled tube will be 20 to 50 percent shorter than for the straight tube or between approximately 4 and 6 m. The flow in the coiled tube is not fully developed, and actual heat transfer rates will exceed those predicted using Equation 8.76. (2) The coiled tube requires  $(2/9.77) \times 100 = 20$  percent of the tube length relative to the straight tube case. (3) The coil length is  $(0.159/9.77) \times 100 = 1.6$  percent that of the straight tube. (4) The pressure drop in the coiled tube is  $(379/775) \times 100 = 48$  percent that of the straight tube. (5) The coiled tube will induce secondary flow in the pharmaceutical, thereby reducing radial temperature gradients in the liquid.

## PROBLEM 8.102

**KNOWN:** Laminar flow within a tube of diameter  $D_o$ . Inner rod diameter,  $D_i$ . Mean fluid temperature,  $T_m$ , and tube wall temperature,  $T_{s,o}$ .

**FIND:** Ratio of heat transfer from the fluid to the tube wall for  $D_i/D_o = 0, 0.10, 0.25$  and  $0.50$ .

**SCHEMATIC:**

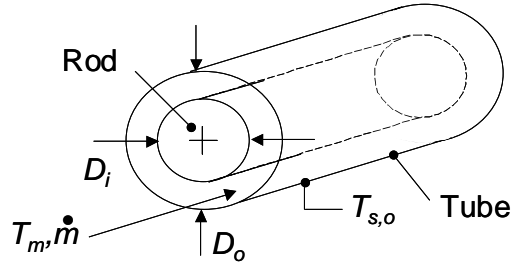

**ASSUMPTIONS:** (1) Fully developed, laminar flow, (2) Constant properties, (3) Negligible conduction in the rod.

**ANALYSIS:** A control volume analysis about the inner rod reveals that there is no heat transfer to or from the rod. Hence, it acts as an insulated surface. Equation 8.68 may be written for the tube where, from Equation 8.70  $h_o = Nu_o k / D_h = Nu_o k / (D_o - D_i)$ . Hence,

$$q_o'' = \frac{Nu_o k (T_{s,o} - T_m)}{D_o (1 - D_i / D_o)} \quad (1)$$

Without the rod,  $D_i/D_o = 0$  and  $Nu_o = 3.66$ , yielding

$$q_{o,wo}'' = \frac{Nu_o k (T_{s,o} - T_m)}{D_o} = \frac{3.66 k (T_{s,o} - T_m)}{D_o} \quad (2)$$

Hence,

$$q_o'' / q_{o,wo}'' = \frac{Nu_o}{3.66(1 - D_i / D_o)}$$

From Table 8.2,

$D_i/D_o$	$Nu_o$	$q_o'' / q_{o,wo}''$	<
0	3.66	1	
0.10	4.11	1.25	
0.25	4.23	1.54	
0.50	4.43	2.42	

**COMMENTS:** (1) The proposed scheme enhances the heat transfer between the fluid and the tube wall, (2) The fluid temperature will change as the fluid flows in the axial direction. If the rod is of relatively high thermal conductivity compared to the fluid, the rod will be at a nearly uniform temperature. Hence, the rod could no longer be considered an insulated surface, since it would cool the fluid in upstream locations, and heat the fluid further downstream for the case where the fluid enters the annular region at a temperature higher than that of the tube wall.

### PROBLEM 8.103

**KNOWN:** Tubing with ethylene glycol welded to transformer to remove dissipated power. Maximum allowable coolant temperature rise of 6°C.

**FIND:** Required coolant flow rate, tube length and lateral spacing of turns.

**SCHEMATIC:**

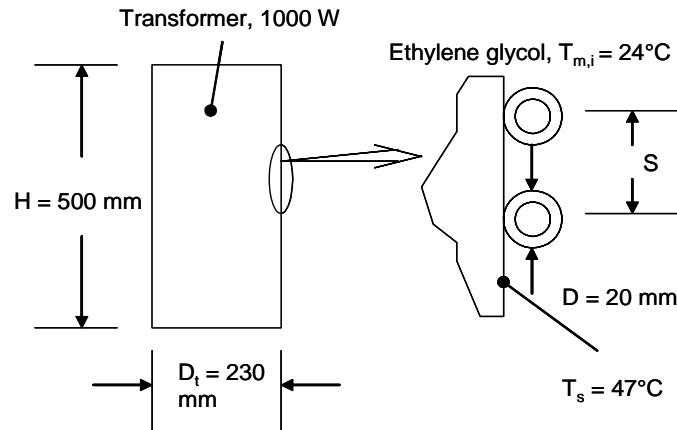

**ASSUMPTIONS:** (1) Constant properties, (2) Incompressible liquid and negligible viscous dissipation, (3) Steady-state conditions, (4) Negligible tube wall thermal resistance, (5) Fully-developed flow, (6) All heat dissipated by transformer is transferred to ethylene glycol.

**PROPERTIES:** Table A.5, ethylene glycol: ( $\bar{T}_m = 300$  K, assumed):  $k = 0.252$  W/m·K,  $c_p = 2415$  J/kg·K,  $\mu_f = 1.57 \times 10^{-2}$  N·s/m<sup>2</sup>,  $Pr = 1151$ .

**ANALYSIS:** From an overall energy balance, the required flow rate is

$$q = \dot{m}c_p(T_{m,o} - T_{m,i}) \quad \text{or} \quad \dot{m} = q/c_p(T_{m,o} - T_{m,i})$$

$$\dot{m} = 1000 \text{ W} / (2415 \text{ J/kg} \cdot \text{K} \times 6\text{K})$$

$$\dot{m} = 6.90 \times 10^{-2} \text{ kg/s}$$

<

From Equation 8.41a the length of tubing may be determined,

$$L = -\frac{\dot{m}c_p}{Ph} \ln\left(\frac{T_s - T_{m,o}}{T_s - T_{m,i}}\right)$$

where  $P = \pi D$ . For the tube flow, find

$$Re_D = \frac{4\dot{m}}{\pi D\mu} = \frac{4 \times 6.90 \times 10^{-2} \text{ kg/s}}{\pi \times 0.020 \text{ m} \times 1.57 \times 10^{-2} \text{ N} \cdot \text{S/m}^2} = 279.8$$

$$C/D = (D_t + D) = 250/20 = 12.5; \quad Re_D(D/C)^{1/2} = 279.8 \times (20/250)^{1/2} = 79.1$$

Equation 8.77 yields

Continued...

### PROBLEM 8.103 (Cont.)

$$a = \left( 1 + \frac{957 \times (250/20)}{(279.8)^2 \times 1151} \right) = 1.0001$$

$$b = 1 + \frac{0.477}{1151} = 1.0004$$

Therefore, Equation 8.76 is

$$\begin{aligned} \text{Nu}_D &= \left[ \left( 3.66 + \frac{4.343}{1.0001} \right)^3 + 1.158 \left( \frac{279.8 \times (20/250)^{1/2}}{1.0004} \right)^{3/2} \right]^{1/3} \\ &= 10.99 \end{aligned}$$

$$\bar{h} = h = \text{Nu}_D \frac{k}{D} = 10.99 \times 252 \times 10^{-3} \text{ W/m} \cdot \text{K} / 20 \times 10^{-3} \text{ m} = 138.5 \text{ W/m}^2 \cdot \text{K}$$

Equation 8.41a becomes

$$L = - \frac{6.90 \times 10^{-2} \text{ kg/s} \times 2415 \text{ J/kg} \cdot \text{K}}{\pi \times 0.02 \text{ m} \times 138.5 \text{ W/m}^2 \cdot \text{K}} \ln \left( \frac{(47 - 30)^\circ\text{C}}{(47 - 24)^\circ\text{C}} \right) = 5.79 \text{ m} \quad <$$

The number of turns of the tubing,  $N$ , is  $N = L/\pi D = 5.79 \text{ m} / \pi(0.025 \text{ m}) = 7.37$  and hence the spacing,  $S$ , is

$$S = H/N = 500 \text{ mm} / 7.37 = 67.8 \text{ mm} \quad <$$

**COMMENT:** (1) Coiling the tube results in a convective heat transfer coefficient that is  $10.99/3.66 = 3$  times larger than the fully-developed value for a straight tube. (2) For a straight tube, the thermal entrance length is  $x_{fd,t} = 0.05 \text{Re}_D \text{Pr}D = 0.05 \times 279.8 \times 1151 \times 0.02 \text{ m} = 322 \text{ m}$ . The flow will not be fully-developed, and care must be taken when using the predictions.

## PROBLEM 8.104

**KNOWN:** Geometry and dimensions of a tube with straight and coiled sections. Temperature and convection coefficient of coolant flowing outside the tube. Inlet temperature, mass flow rate, and properties of pharmaceutical fluid in tube.

**FIND:** (a) Outlet temperature of pharmaceutical, (b) Outlet temperature with inner heat transfer coefficient doubled in straight sections, (c) Effect of left- or right-handed spiral.

**SCHEMATIC:**

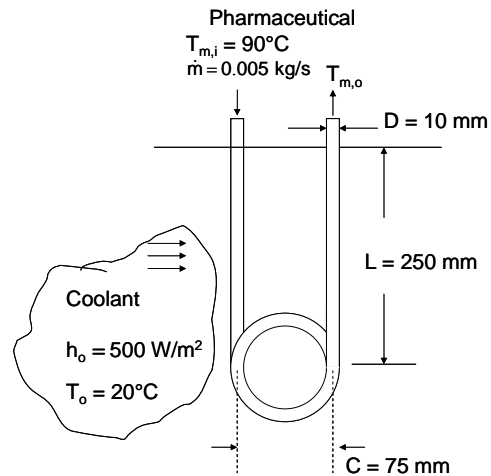

**ASSUMPTIONS:** (1) Tube wall thermal resistance is negligible. (2) Flow is fully-developed in coiled section. (3) Flow in last straight section is unaffected by swirl introduced in coiled section. (4) Constant properties.

**PROPERTIES:** Pharmaceutical fluid (given):  $\rho = 1200 \text{ kg/m}^3$ ,  $\mu = 4 \times 10^{-3} \text{ N}\cdot\text{s/m}^2$ ,  $c_p = 2000 \text{ J/kg}\cdot\text{K}$ ,  $k = 0.5 \text{ W/m}\cdot\text{K}$ ,  $\text{Pr} = \mu c_p/k = 16$ .

**ANALYSIS:**

(a) The Reynolds number is

$$\text{Re}_D = \frac{4 \dot{m}}{\pi D \mu} = \frac{4 \times 0.005 \text{ kg/s}}{\pi \times 0.01 \text{ m} \times 4 \times 10^{-3} \text{ N}\cdot\text{s/m}^2} = 159$$

Thus the flow is laminar.

1<sup>st</sup> Straight Section. The development length in the straight section is

$$x_{fd,h} = 0.05 \text{ Re}_D D = 0.05 \times 159 \times 0.01 \text{ m} = 0.08 \text{ m}$$

$$x_{fd,t} = x_{fd,h} \cdot \text{Pr} = 0.08 \text{ m} \times 16 = 1.3 \text{ m}$$

The flow is thermally developing. With  $\text{Pr} > 5$ , we can use Equation 8.57 with Equation 8.56,

$$\overline{\text{Nu}}_D = 3.66 + \frac{0.0668 (D/L) \text{Re}_D \text{Pr}}{1 + 0.04 [(D/L) \text{Re}_D \text{Pr}]^{2/3}} = 7.29$$

Thus  $h_i = \overline{\text{Nu}}_D k/D = 7.29 \times 0.5 \text{ W/m}\cdot\text{K}/0.01 \text{ m} = 365 \text{ W/m}^2 \cdot \text{K}$ .

Continued...

### PROBLEM 8.104 (Cont.)

The mean temperature at the end of the first straight section can be found from Equation 8.45a,

$$T_{m,o1} = T_{\infty} + (T_{m,i} - T_{\infty}) \exp\left(-\frac{\bar{U}A_s}{\dot{m}c_p}\right)$$

where  $\bar{U} = [1/h_i + 1/h_o]^{-1} = [1/365 \text{ W/m}^2 \cdot \text{K} + 1/500 \text{ W/m}^2 \cdot \text{K}]^{-1} = 211 \text{ W/m}^2 \cdot \text{K}$ .

$$\text{Thus } T_{m,o1} = 20^\circ\text{C} + (90^\circ\text{C} - 20^\circ\text{C}) \exp\left(-\frac{211 \text{ W/m}^2 \cdot \text{K} \times \pi \times 0.01 \text{ m} \times 0.25 \text{ m}}{0.005 \text{ kg/s} \times 2000 \text{ J/kg} \cdot \text{K}}\right) = 79.3^\circ\text{C}$$

Coiled Section. The critical Reynolds number in the coiled section is given by Equation 8.74,

$$Re_{D,C,h} = Re_{D,C} [1 + 12(D/C)^{0.5}]$$

where  $Re_{D,C} = 2300$ . Since this must be greater than 2300, the flow in the coiled section, with  $Re_D = 159$ , is still laminar. The length of the coiled section is  $6.5 \pi C = 6.5 \pi (0.075 \text{ m}) = 1.53 \text{ m}$ . Since development lengths are 20 to 50% shorter in coiled tubes than in straight tubes the flow can be approximated as fully developed. The Nusselt number is given by Equation 8.76, with

$$a = \left[1 + \frac{957 (C/D)}{Re_D^2 Pr}\right] = \left[1 + \frac{957 (75 \text{ mm}/10 \text{ mm})}{(159)^2 \times 16}\right] = 1.018$$

and  $b = 1 + 0.477/Pr = 1 + 0.477/16 = 1.030$ . Note that  $Re_D (D/C)^{1/2} = 58$ , therefore the criteria for using Equations 8.76 and 8.77 are satisfied. Thus assuming  $\mu_s = \mu$ ,

$$\begin{aligned} Nu_D &= \left[ \left( 3.66 + \frac{4.343}{a} \right)^3 + 1.158 \left( \frac{Re_D (D/C)^{1/2}}{b} \right)^{3/2} \right]^{1/3} \\ &= \left[ \left( 3.66 + \frac{4.343}{1.018} \right)^3 + 1.158 \left( \frac{159 (10 \text{ mm}/75 \text{ mm})^{1/2}}{1.030} \right)^{3/2} \right]^{1/3} = 9.96 \end{aligned}$$

and  $h_i = Nu_D k/D = 498 \text{ W/m}^2 \cdot \text{K}$ .

Then  $\bar{U} = [1/h_i + 1/h_o]^{-1} = [1/498 \text{ W/m}^2 \cdot \text{K} + 1/500 \text{ W/m}^2 \cdot \text{K}]^{-1} = 250 \text{ W/m}^2 \cdot \text{K}$ .

The outlet temperature of the coiled section can be found from Equation 8.45a, with  $A_s = (\pi D)(6.5 \pi C) = 0.048 \text{ m}^2$ , and the inlet temperature is the outlet temperature of the straight section:

$$T_{m,o2} = T_{\infty} + (T_{m,o1} - T_{\infty}) \exp\left(-\frac{\bar{U}A_s}{\dot{m}c_p}\right)$$

$$T_{m,o2} = 20^\circ\text{C} + (79.3^\circ\text{C} - 20^\circ\text{C}) \exp\left(-\frac{250 \text{ W/m}^2 \cdot \text{K} \times 0.048 \text{ m}^2}{0.005 \text{ kg/s} \times 2000 \text{ J/kg} \cdot \text{K}}\right) = 37.9^\circ\text{C}$$

Continued...

### PROBLEM 8.104 (Cont.)

2<sup>nd</sup> Straight Section. The overall heat transfer coefficient would be the same as in the 1<sup>st</sup> straight section. The outlet temperature can be calculated from Equation 8.45a with the inlet temperature equal to the outlet temperature of the coiled section.

$$T_{m,03} = T_{\infty} + (T_{m,02} - T_{\infty}) \exp\left(-\frac{\bar{U}A_s}{\dot{m}c_p}\right)$$

$$T_{m,03} = 20^{\circ}\text{C} + (37.9^{\circ}\text{C} - 20^{\circ}\text{C}) \exp\left(-\frac{211 \text{ W/m}^2 \cdot \text{K} \times \pi \times 0.01 \text{ m} \times 0.25 \text{ m}^2}{0.005 \text{ kg/s} \times 2000 \text{ J/kg} \cdot \text{K}}\right)$$

$$T_{m,03} = 35.1^{\circ}\text{C}$$

&lt;

(b) Repeating the calculations with  $h_i$  in the straight sections doubled, in the 1<sup>st</sup> straight section:

$$\bar{U} = \left[1/730 \text{ W/m}^2 \cdot \text{K} + 1/500 \text{ W/m}^2 \cdot \text{K}\right]^{-1} = 297 \text{ W/m}^2 \cdot \text{K}$$

$$T_{m,01} = 75.4^{\circ}\text{C}$$

In the coiled section,  $\bar{U}$  is unchanged, and

$$T_{m,02} = 36.7^{\circ}\text{C}$$

In the 2<sup>nd</sup> straight section,  $\bar{U} = 297 \text{ W/m}^2 \cdot \text{K}$  and

$$T_{m,03} = 33.2^{\circ}\text{C}$$

(c) Yes, the orientation of the springs could have an effect, because they introduce swirl that interacts with the swirl introduced in the coiled section. However, the effect is probably small.

**COMMENTS:** The analysis is only approximate. In particular, the flow in the last section would be affected by the swirl introduced in the coiled section, which would in turn affect the heat transfer.



## PROBLEM 8.105

**KNOWN:** Pressurized water inlet temperature and total mass flow rate for mold cooling and heating. Water channel dimensions for conventional and conformally-cooled mold. Initial hot and cold mold temperatures, mold dimensions and mold properties.

**FIND:** (a) Initial heating rate of a cold (100°C) mold, initial cooling rate of a hot (200°C) mold for straight water channels with  $D = 50$  mm, (b) Initial heating rate of a cold (100°C) mold, initial cooling rate of a hot (200°C) mold for a conformally-cooled mold with water channels of diameter  $D = 50$  mm, (c) Surface areas of cooling/heating channels for both molds and determination of which mold will enable production of more parts per day.

**SCHEMATIC:**

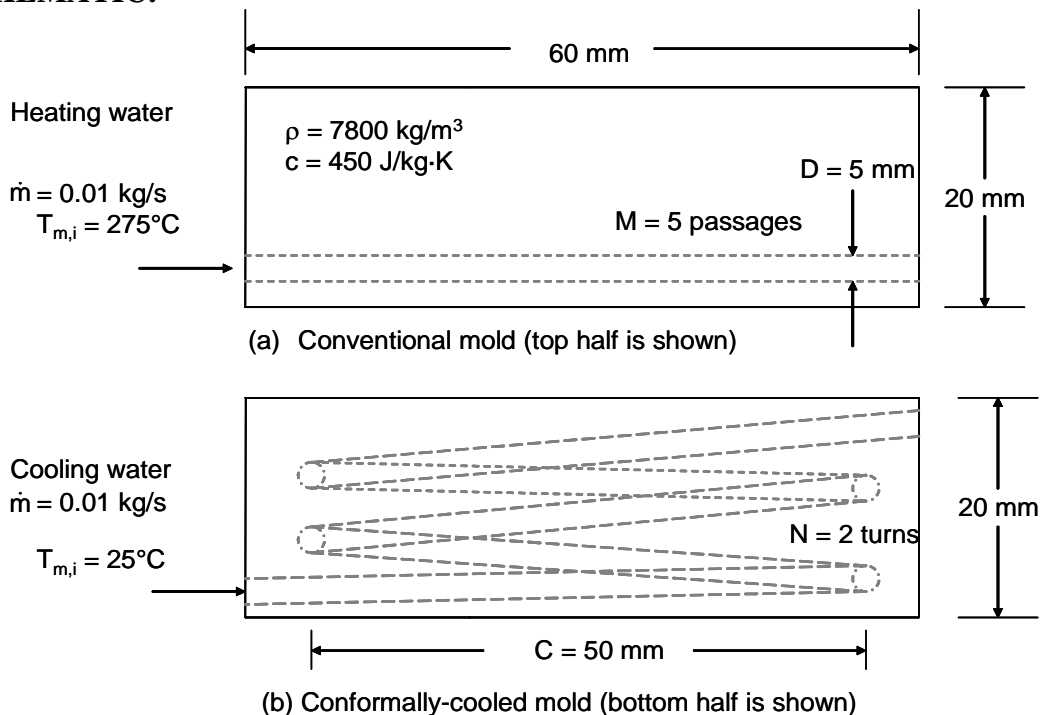

**ASSUMPTIONS:** (1) Constant properties, (2) Incompressible liquid and negligible viscous dissipation, (3) Fully developed hydrodynamic conditions at the entrance, (4) Negligible part mass, (5) Water sufficiently pressurized to prevent boiling, (6) Negligible heat transfer in short straight sections of the channel for the conformally-cooled case.

**PROPERTIES:** Table A.6, water: ( $\bar{T}_m = 260^\circ\text{C}$ , assumed):  $k = 0.6038$  W/m·K,  $c_p = 4989$  J/kg·K,  $\mu = 103.1 \times 10^{-6}$  N·s/m<sup>2</sup>,  $Pr = 0.853$ . ( $\bar{T}_m = 40^\circ\text{C}$ , assumed):  $k = 0.6316$  W/m·K,  $c_p = 4179$  J/kg·K,  $\mu = 656.6 \times 10^{-6}$  N·s/m<sup>2</sup>,  $Pr = 4.344$ . ( $T_s = 200^\circ\text{C}$ ):  $\mu_s = 133.9 \times 10^{-6}$  N·s/m<sup>2</sup>.

Continued...

### PROBLEM 8.105 (Cont.)

**ANALYSIS:** (a) Heating,  $\overline{T}_m = 260^\circ\text{C}$ . The Reynolds number is

$$\text{Re}_D = \frac{4\dot{m}}{\pi D\mu} = \frac{(4 \times 0.01 \text{ kg/s})/5}{\pi \times 5 \times 10^{-3} \text{ m} \times 103.1 \times 10^{-6} \text{ N}\cdot\text{s}/\text{m}^2} = 4940$$

From the Gnielinski correlation, with  $f = (0.790 \ln \text{Re}_D - 1.64)^{-2} = (0.790 \ln 4940 - 1.64)^{-2} = 38.8 \times 10^{-3}$ ,

$$\text{Nu}_D = \frac{(f/8)(\text{Re}_D - 1000)\text{Pr}}{1 + 12.7(f/8)^{1/2}(\text{Pr}^{2/3} - 1)} = \frac{(38.8 \times 10^{-3}/8) \times (4940 - 1000) \times 0.853}{1 + 12.7(38.8 \times 10^{-3}/8)^{1/2}(0.853^{2/3} - 1)} = 17.89$$

Therefore,  $h_D = \text{Nu}_D k/D = 17.89 \times 0.6038 \text{ W/m}\cdot\text{K}/5 \times 10^{-3} \text{ m} = 2161 \text{ W/m}^2\cdot\text{K}$ . For  $P = \pi D = \pi \times 5 \times 10^{-3} \text{ m} = 15.7 \times 10^{-3} \text{ m}$ ,  $L = 60 \times 10^{-3} \text{ m}$ ,  $\dot{m} = 0.01 \text{ kg/s}/5 = 0.002 \text{ kg/s}$ , Equation 8.42 is written

$$\frac{100 - T_{m,o}}{100 - 275} = \exp\left(-\frac{15.7 \times 10^{-3} \text{ m} \times 60 \times 10^{-3} \text{ m} \times 2161 \text{ W/m}^2\cdot\text{K}}{0.002 \text{ kg/s} \times 4989 \text{ J/kg}\cdot\text{K}}\right)$$

from which  $T_{m,o} = 243^\circ\text{C}$ . Therefore,

$$q_w = \dot{m}c_p(T_{m,o} - T_{m,i}) = 0.002 \text{ kg/s} \times 4989 \text{ J/kg}\cdot\text{K} \times (243^\circ\text{C} - 275^\circ\text{C}) = 319 \text{ W/channel and, for}$$

$$\text{the entire mold, } q_h = -q_w \times M \times 2 = 319 \text{ W} \times 5 \times 2 = 3190 \text{ W} \quad <$$

Cooling,  $\overline{T}_m = 40^\circ\text{C}$ . The Reynolds number is

$$\text{Re}_D = \frac{4\dot{m}}{\pi D\mu} = \frac{(4 \times 0.01 \text{ kg/s})/5}{\pi \times 5 \times 10^{-3} \text{ m} \times 656.6 \times 10^{-6} \text{ N}\cdot\text{s}/\text{m}^2} = 776$$

Using Equation 8.56,

$$\text{Nu}_D = 3.66 + \frac{0.0668(D/L)\text{Re}_D\text{Pr}}{1 + 0.04[(D/L)\text{Re}_D\text{Pr}]^{2/3}} = 3.66 + \frac{0.0668(5/60) \times 776 \times 4.344}{1 + 0.04[(5/60) \times 776 \times 4.344]^{2/3}} = 10.57$$

Therefore,  $h_D = \text{Nu}_D k/D = 10.57 \times 0.6316 \text{ W/m}\cdot\text{K}/5 \times 10^{-3} \text{ m} = 1335 \text{ W/m}^2\cdot\text{K}$ . Equation 8.42 yields

$$\frac{200 - T_{m,o}}{100 - 25} = \exp\left(-\frac{15.7 \times 10^{-3} \text{ m} \times 60 \times 10^{-3} \text{ m} \times 1335 \text{ W/m}^2\cdot\text{K}}{0.002 \text{ kg/s} \times 4179 \text{ J/kg}\cdot\text{K}}\right)$$

from which  $T_{m,o} = 49.4^\circ\text{C}$ . Therefore,

$$q_w = \dot{m}c_p(T_{m,o} - T_{m,i}) = 0.002 \text{ kg/s} \times 4179 \text{ J/kg}\cdot\text{K} \times (49.4^\circ\text{C} - 25^\circ\text{C}) = 203.9 \text{ W/channel and, for}$$

$$\text{the entire mold, } q_c = -q_w \times M \times 2 = -203.9 \text{ W} \times 5 \times 2 = -2039 \text{ W} \quad <$$

Continued...

**PROBLEM 8.105 (Cont.)**

(b) Heating,  $\overline{T}_m = 260^\circ\text{C}$ . The critical Reynolds number is

$$\text{Re}_{D,c,h} = \text{Re}_{D,c} \left[ 1 + 12(D/C)^{0.5} \right] = 2300 \times \left[ 1 + 12(5/50)^{0.5} \right] = 11030. \text{ The actual}$$

Reynolds number is  $\text{Re}_D = \frac{4\dot{m}}{\pi D\mu} = \frac{4 \times 0.01 \text{ kg/s}}{\pi \times 5 \times 10^{-3} \text{ m} \times 103.1 \times 10^{-6} \text{ N}\cdot\text{s/m}^2} = 24700$  and the flow is turbulent. Using the Gnielinski correlation, with  $f = (0.790 \ln \text{Re}_D - 1.64)^{-2} = (0.790 \ln 24700 - 1.64)^{-2} = 24.8 \times 10^{-3}$ ,

$$\text{Nu}_D = \frac{(f/8)(\text{Re}_D - 1000)\text{Pr}}{1 + 12.7(f/8)^{1/2}(\text{Pr}^{2/3} - 1)} = \frac{(24.8 \times 10^{-3}/8) \times (24700 - 1000) \times 0.853}{1 + 12.7(24.8 \times 10^{-3}/8)^{1/2}(0.853^{2/3} - 1)} = 62.67$$

Therefore,  $h_D = \text{Nu}_D k/D = 62.67 \times 0.6038 \text{ W/m}\cdot\text{K}/5 \times 10^{-3} \text{ m} = 7570 \text{ W/m}^2\cdot\text{K}$ . For  $P = 15.7 \times 10^{-3} \text{ m}$ ,  $L = 2\pi C = 2 \times \pi \times 50 \times 10^{-3} \text{ m} = 0.314 \text{ m}$ , and  $\dot{m} = 0.01 \text{ kg/s}$ , Equation 8.42 is written as

$$\frac{100 - T_{m,o}}{100 - 275} = \exp\left(-\frac{15.7 \times 10^{-3} \text{ m} \times 0.314 \text{ m} \times 7570 \text{ W/m}^2\cdot\text{K}}{0.01 \text{ kg/s} \times 4989 \text{ J/kg}\cdot\text{K}}\right)$$

from which  $T_{m,o} = 182.8^\circ\text{C}$ . Then,  $q_h = 0.02 \text{ kg/s} \times 4989 \text{ J/kg}\cdot\text{K} \times (182.8^\circ\text{C} - 275^\circ\text{C}) = 9197 \text{ W} <$

Cooling,  $\overline{T}_m = 40^\circ\text{C}$ . The Reynolds number is

$$\text{Re}_D = \frac{4\dot{m}}{\pi D\mu} = \frac{(4 \times 0.01 \text{ kg/s})}{\pi \times 5 \times 10^{-3} \text{ m} \times 656.6 \times 10^{-6} \text{ N}\cdot\text{s/m}^2} = 3880$$

Since  $\text{Re}_D < \text{Re}_{D,c,h}$ , the flow is laminar and  $\text{Re}_D(D/C)^{1/2} = 3880 \times (5/50)^{1/2} = 1227$ . The values of a and b for use in Equation 8.77 are

$$a = \left( \frac{1 + 957(C/D)}{\text{Re}_D^2 \text{Pr}} \right) = \left( \frac{1 + 957 \times (50/5)}{3880^2 \times 4.344} \right) = 146 \times 10^{-3}; \quad b = 1 + \frac{0.477}{\text{Pr}} = -1 + \frac{0.477}{4.344} = 1.11$$

Equation 8.76 is rearranged to yield

$$h_D = \frac{0.6316 \text{ W/m}\cdot\text{K}}{5 \times 10^{-3} \text{ m}} \left[ \left( 3.66 + \frac{4.343}{146 \times 10^{-3}} \right)^3 + 1.158 \times \left( \frac{1227}{1.11} \right)^{3/2} \right]^{1/3} \left( \frac{656}{133.9} \right)^{0.14} = 6794 \text{ W/m}^2\cdot\text{K}$$

Equation 8.42 is written

Continued...

**PROBLEM 8.105 (Cont.)**

$$\frac{200 - T_{m,o}}{100 - 25} = \exp\left(-\frac{15.7 \times 10^{-3} \text{ m} \times 0.314 \text{ m} \times 6794 \text{ W/m}^2 \cdot \text{K}}{0.01 \text{ kg/s} \times 4179 \text{ J/kg} \cdot \text{K}}\right)$$

from which  $T_{m,o} = 121.5^\circ\text{C}$ . Therefore,

$$q_c = \dot{m}c_p(T_{m,o} - T_{m,i}) = 0.02 \text{ kg/s} \times 4179 \text{ J/kg} \cdot \text{K} \times (25^\circ\text{C} - 121.5^\circ\text{C}) = -8065 \text{ W}$$

<

(c) For the conventional mold,

$A_{cp} = 2M\pi DL = 2 \times 5 \times \pi \times 5 \times 10^{-3} \text{ m} \times 60 \times 10^{-3} \text{ m} = 9.42 \times 10^{-3} \text{ m}^2$ . For the conformally-cooled mold,  $A_{cc} = 2N\pi C\pi D = 2 \times 2 \times \pi^2 \times 50 \times 10^{-3} \text{ m} \times 5 \times 10^{-3} \text{ m} = 9.87 \times 10^{-3} \text{ m}^2$ .

The time rate of change of the mold temperature is

$$\frac{dT}{dt} = \frac{q}{V\rho C} = \frac{q}{(60 \times 10^{-3} \text{ m})^2 \times 40 \times 10^{-3} \text{ m} \times 7800 \text{ kg/m}^3 \times 450 \text{ J/kg} \cdot \text{K}} = \frac{q}{505.4 \text{ W} \cdot \text{s/K}}$$

The results are summarized in the following table.

Mold Type	q (W)	Flow Regime	dT/dt (K/s)
Conventional heating	3190	turbulent	6.51
Conventional cooling	-2039	laminar	4.03
Conformal heating	9197	turbulent	18.20
Conformal cooling	-8065	laminar enhanced	15.96

The conformally-cooled mold will increase production by a factor of 3 to 4 times, using the same cooling area.

**COMMENTS:** (1) The average mean temperature for heating is  $258.8^\circ\text{C}$  and  $230^\circ\text{C}$  for the conventional and conformally-cooled molds, respectively. The assumed average mean temperature ( $260^\circ\text{C}$ ) is very good for the conventional mold case. A more accurate solution would be obtained by re-calculating the answer for the conformally-cooled case based upon a better estimate of the average mean temperature. (2) The average mean temperature for cooling is  $37.2^\circ\text{C}$  and  $73.3^\circ\text{C}$  for the conventional and conformally-cooled molds, respectively. The assumed average mean temperature for cooling ( $40^\circ\text{C}$ ) is very good for the conventional mold case. A more accurate solution would be obtained by re-calculating the answer for the conformally-cooled case based upon a better estimate of the average mean temperature. (3) The conformally-cooled mold offers enhanced performance due to higher mean velocity in the case of heating, and enhanced laminar flow due to curvature in the case of cooling. (4) Equation 8.76 has been extended slightly beyond its range of recommended application. Care should be taken in using the predictions.

## PROBLEM 8.106

**KNOWN:** Inlet temperatures and flow rates of a pharmaceutical product and pressurized water, tube diameter, coil diameter and number of coils.

**FIND:** (a) The outlet temperature of the pharmaceutical product, (b) The variation of the pharmaceutical outlet temperature with the pressurized water flow rate.

**SCHEMATIC:**

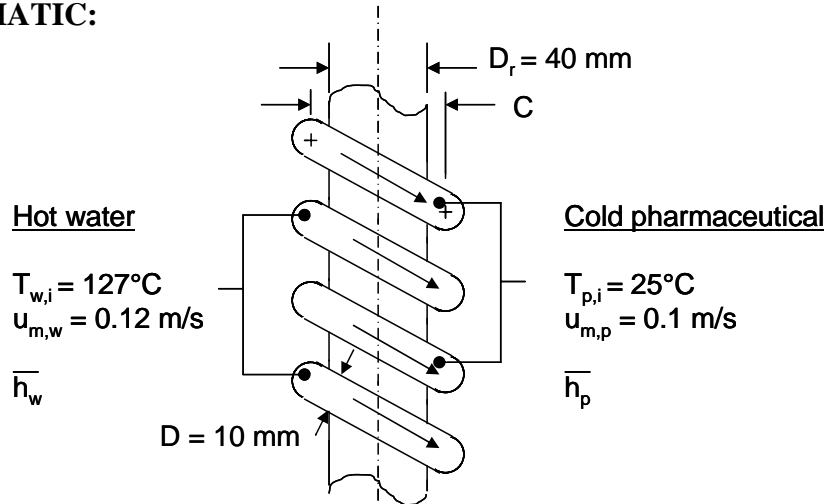

**ASSUMPTIONS:** (1) Constant properties and steady-state conditions, (2) Incompressible liquid and negligible viscous dissipation, (3) Fully developed flow, (4) Negligible tube wall thermal resistance, (5) Negligible heat loss to surroundings and ambient.

**PROPERTIES:** Table A.6, water: ( $\bar{T}_m = 380 \text{ K}$ ):  $k = 0.683 \text{ W/m}\cdot\text{K}$ ,  $c_p = 4226 \text{ J/kg}\cdot\text{K}$ ,  $\mu = 260 \times 10^{-6} \text{ N}\cdot\text{s/m}^2$ ,  $Pr = 1.61$ ,  $\rho = 953.3 \text{ kg/m}^3$ . Pharmaceutical (given):  $k = 0.80 \text{ W/m}\cdot\text{K}$ ,  $c_p = 4000 \text{ J/kg}\cdot\text{K}$ ,  $\mu = 2 \times 10^{-3} \text{ kg/s}\cdot\text{m}$ ,  $Pr = 10$ ,  $\rho = 1000 \text{ kg/m}^3$ .

**ANALYSIS:** For the water,

$$\dot{m}_w = \frac{\rho u_w \pi D^2}{4} = \frac{953.3 \text{ kg/m}^3 \times 0.12 \text{ m/s} \times \pi \times (0.01 \text{ m})^2}{4} = 0.00899 \text{ kg/s}$$

$$Re_{D,w} = \frac{4\dot{m}_w}{\pi D \mu} = \frac{4 \times 0.00899 \text{ kg/s}}{\pi \times 0.01 \text{ m} \times 260 \times 10^{-6} \text{ kg/s}\cdot\text{m}} = 4400$$

For the pharmaceutical,

$$\dot{m}_p = \frac{\rho u_p \pi D^2}{4} = \frac{1000 \text{ kg/m}^3 \times 0.10 \text{ m/s} \times \pi \times (0.01 \text{ m})^2}{4} = 0.00785 \text{ kg/s}$$

Continued...

**PROBLEM 8.106 (Cont.)**

$$\text{Re}_{D,p} = \frac{4\dot{m}_p}{\pi D\mu} = \frac{4 \times 0.00785 \text{ kg/s}}{\pi \times 0.01 \text{ m} \times 2 \times 10^{-3} \text{ kg/s} \cdot \text{m}} = 500$$

The flow of the pharmaceutical is laminar ( $\text{Re}_{D,p} < 2300$ ). For the coiled tube,  $C = D_r + 2(D/2) = 40 \text{ mm} + 2 \times 5 \text{ mm} = 50 \text{ mm}$ . Using Equation 8.74,  $\text{Re}_{D,c,h,w} = 2300[1 + 12 \times (10/50)^{0.5}] = 14,640$ . Therefore, the flow of the pressurized water is laminar ( $\text{Re}_{D,w} = 4400 < 14,640$ ).

For the pharmaceutical product,  $\text{Re}_{D,p}(D/C)^{1/2} = 500 \times (10/50)^{1/2} = 223$ , while for the water  $\text{Re}_{D,w}(D/C)^{1/2} = 4400 \times (10/50)^{1/2} = 1967$ . For each tube,  $C/D = 50/10 = 5 > 3$ .

For the pharmaceutical product and water, the overall energy balances are

$$q = \dot{m}_p c_{p,p} (T_{p,o} - T_{p,i}) \quad ; \quad q = \dot{m}_w c_{p,w} (T_{w,i} - T_{w,o}) \quad (1,2)$$

For the pharmaceutical and water, Equation 8.42 is

$$\frac{T_s - T_{p,o}}{T_s - T_{p,i}} = \exp\left(-\frac{\pi DL}{\dot{m}_p c_{p,p}} \bar{h}_p\right) \quad ; \quad \frac{T_s - T_{w,o}}{T_s - T_{w,i}} = \exp\left(-\frac{\pi DL}{\dot{m}_w c_{p,w}} \bar{h}_w\right) \quad (3,4)$$

Once we determine  $\bar{h}_p$  and  $\bar{h}_w$ , we may solve Equations (1) through (4) simultaneously for four unknowns:  $q$ ,  $T_{p,o}$ ,  $T_{w,o}$  and  $T_s$ . We will use Equation 8.76, but be aware that we are using the correlation outside of its recommended range of applicability for the water. For the pharmaceutical product, Equation 8.77 yields

$$a = \left(1 + \frac{957 \times (50/10)}{(500)^2 \times 10}\right) = 1.002 \quad ; \quad b = 1 + \frac{0.477}{10} = 1.048$$

Therefore, Equation 8.76 becomes

$$\text{Nu}_{D,p} = \left[ \left(3.66 + \frac{4.343}{1.002}\right)^3 + 1.158 \left(\frac{500(10/50)^{1/2}}{1.048}\right)^{3/2} \right]^{1/3} = 16.03$$

Therefore,  $\bar{h}_p = \text{Nu}_{D,p} k_p / D = 16.03 \times 0.80 \text{ W/m} \cdot \text{K} / 0.01 \text{ m} = 1283 \text{ W/m}^2 \cdot \text{K}$ . For the pressurized water, Equation 8.77 yields

$$a = \left(1 + \frac{957 \times (50/10)}{(4400)^2 \times 1.61}\right) = 1.00 \quad ; \quad b = 1 + \frac{0.477}{1.61} = 1.296$$

Continued...

### PROBLEM 8.106 (Cont.)

Proceeding as before, we find  $Nu_{D,w} = 41.01$ ,  $\overline{h_w} = 2801 \text{ W/m}^2 \cdot \text{K}$ . The tube length is  $L = N \times \pi \times D_f = 20 \times \pi \times 0.05 \text{ m} = 3.14 \text{ m}$ . Substituting values into Equations (1) through (4) and solving simultaneously yields

$$q = 1736 \text{ W}, T_{p,o} = 80.25^\circ\text{C}, T_{w,o} = 81.28^\circ\text{C}, T_s = 81.25^\circ\text{C}$$

<

(b) The dependence of the pharmaceutical outlet temperature on the water velocity is shown in the graph below. Note that the pharmaceutical product's outlet temperature can be controlled accurately by modifying the water flow rate.

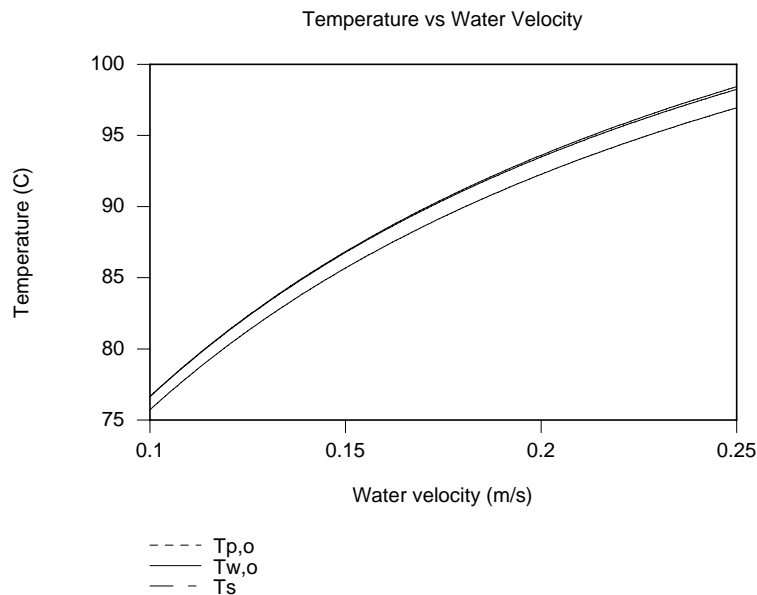

**COMMENTS:** (1) The pharmaceutical outlet temperature will be relatively uniform across the diameter of the tube due to mixing associated with secondary flow. (2) Although we have applied Equation 8.76 outside of its range of general applicability, the actual behavior is not expected to be significantly different than predicted. That is, we would still expect the pharmaceutical outlet temperature to be highly controllable by adjusting the water flow rate. Actual outlet temperatures could be easily measured and the water flow rate adjusted to provide the desired thermal response. (3) The average mean water temperature is  $\overline{T}_m = (T_{w,i} + T_{w,o})/2 = (127^\circ\text{C} + 81.3^\circ\text{C})/2 = 104^\circ\text{C} = 377 \text{ K}$ . The assumed mean temperature of 380 K is reasonable.

### PROBLEM 8.107

**KNOWN:** Chip and cooling channel dimensions. Channel flowrate and inlet temperature. Chip temperature.

**FIND:** Water outlet temperature and chip power.

**SCHEMATIC:**

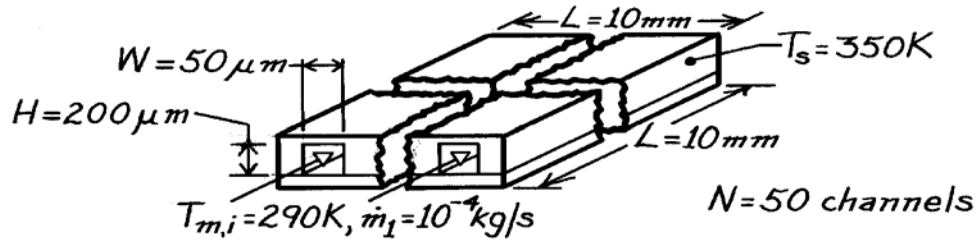

**ASSUMPTIONS:** (1) Incompressible liquid with negligible viscous dissipation, (2) Uniform channel surface temperature, (3)  $\bar{T}_m = 300$  K, (4) Fully developed flow.

**PROPERTIES:** Table A-6, Water ( $\bar{T}_m = 300$  K):  $c_p = 4179$  J/kg·K,  $\mu = 855 \times 10^{-6}$  kg/s·m,  $k = 0.613$  W/m·K,  $Pr = 5.83$ .

**ANALYSIS:** Using the hydraulic diameter, find the Reynolds number,

$$D_h = \frac{4(H \times W)}{2(H + W)} = \frac{2(50 \times 200) \mu\text{m}^2}{250 \mu\text{m}} 10^{-6} \text{ m}/\mu\text{m} = 8 \times 10^{-5} \text{ m}$$

$$Re_D = \frac{\rho u_m D_h}{\mu} = \frac{\dot{m}_1 D_h}{A_c \mu} = \frac{10^{-4} \text{ kg/s} (8 \times 10^{-5} \text{ m})}{(50 \times 200) 10^{-12} \text{ m}^2 (855 \times 10^{-6} \text{ kg/s} \cdot \text{m})} = 936.$$

Hence, the flow is laminar and, from Table 8.1,  $Nu_D = 4.44$ , so that

$$h = Nu_D \frac{k}{D_h} = \frac{4.44(0.613 \text{ W/m} \cdot \text{K})}{8 \times 10^{-5} \text{ m}} = 34,022 \text{ W/m}^2 \cdot \text{K}.$$

With  $P = 2(H + W) = 2(250 \mu\text{m}) 10^{-6} \text{ m}/\mu\text{m} = 5 \times 10^{-4} \text{ m}$ , Eq. 8.41b yields

$$\frac{T_s - T_{m,o}}{T_s - T_{m,i}} = \frac{350\text{K} - T_{m,o}}{60 \text{ K}} = \exp\left(-\frac{PL}{\dot{m}_1 c_p} h\right) = \exp\left(-\frac{5 \times 10^{-6} \text{ m}^2 \times 34,022 \text{ W/m}^2 \cdot \text{K}}{10^{-4} \text{ kg/s} \times 4179 \text{ J/kg} \cdot \text{K}}\right)$$

$$T_{m,o} = 350\text{K} - 60 \text{ K} \exp(-0.407) = 310 \text{ K}. \quad <$$

Hence, from Eq. 8.34,

$$q = \dot{m} c_p (T_{m,o} - T_{m,i}) = N \dot{m}_1 c_p (T_{m,o} - T_{m,i}) = 50 \times 10^{-4} \text{ kg/s} (4179 \text{ J/kg} \cdot \text{K}) (20 \text{ K}) = 418 \text{ W}. \quad <$$

**COMMENTS:** (1) The chip heat flux of  $418 \text{ W/cm}^2$  is extremely large and the method provides a very efficient means of heat removal from high power chips. However, clogging of the microchannels is a potential problem which could seriously compromise reliability. (2)  $L/D_h = 125$  and  $0.05 Re_D Pr = 272$ . Hence, fully developed conditions are not realized and  $\bar{h} > 34,022$ . The actual power dissipation is therefore greater than 418 W.



## PROBLEM 8.108

**KNOWN:** Flow of an ideal gas through a small diameter tube.

**FIND:** Expression for the transition density, below which microscale effects become important. Value of the transition density for hydrogen, air and carbon dioxide.

**SCHEMATIC:**

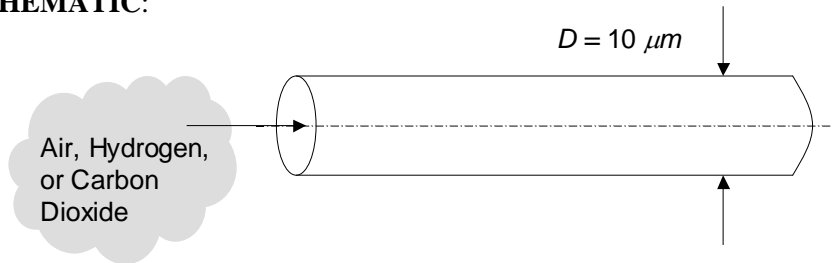

**ASSUMPTIONS:** (1) Constant properties, (2) Ideal gas.

**PROPERTIES:** Figure 2.8 and Table A.4 ( $p = 1 \text{ atm}$ ,  $T = 300 \text{ K}$ ) Air:  $\mathcal{M} = 28.97 \text{ kmol/kg}$ ,  $d = 0.372 \text{ nm}$ ,  $\rho = 1.161 \text{ kg/m}^3$ ,  $\text{H}_2$ :  $\mathcal{M} = 2.016 \text{ kmol/kg}$ ,  $d = 0.274 \text{ nm}$ ,  $\rho = 0.0808 \text{ kg/m}^3$ ,  $\text{CO}_2$ :  $\mathcal{M} = 44.01 \text{ kmol/kg}$ ,  $d = 0.464 \text{ nm}$ ,  $\rho = 1.773 \text{ kg/m}^3$ .

**ANALYSIS:** From Eq. 2.11 the mean free path is

$$\lambda_{\text{mfp}} = \frac{k_B T}{\sqrt{2} \pi d^2 p}$$

and from the ideal gas equation of state,  $p = \rho \mathcal{R} T / \mathcal{M}$ . Microscale effects become important at  $\lambda_{\text{mfp}} / D \approx 0.01$ . Therefore,

$$\frac{\lambda_{\text{mfp}}}{D} = 0.01 = \frac{k_B \mathcal{M}}{\sqrt{2} \pi d^2 \rho_c \mathcal{R} D} \quad \text{or} \quad \rho_c = \frac{100 k_B \mathcal{M}}{\sqrt{2} \pi d^2 \mathcal{R} D}$$

<

For air,

$$\rho_{c,\text{Air}} = \frac{100 k_B \mathcal{M}}{\sqrt{2} \pi d^2 \mathcal{R} D} = \frac{100 \times 1.381 \times 10^{-23} \text{ J/K} \times 28.97 \text{ kmol/kg}}{\sqrt{2} \pi \times (0.372 \times 10^{-9} \text{ m})^2 \times 8315 \text{ J/kmol} \cdot \text{K} \times 10 \times 10^{-6} \text{ m}} = 0.783 \text{ kg/m}^3 \quad <$$

Repeating the calculation for hydrogen and  $\text{CO}_2$  yields

$$\rho_{c,\text{H}_2} = 0.100 \text{ kg/m}^3; \quad \rho_{c,\text{CO}_2} = 0.764 \text{ kg/m}^3. \quad <$$

The ratios of the transition to molecular density at  $p = 1 \text{ atm}$ ,  $T = 300 \text{ K}$ , for the three gases are:

Gas	Ratio
Air	$0.783/1.161 = 0.674$
$\text{H}_2$	$0.100/0.0808 = 1.24$
$\text{CO}_2$	$0.764/1.773 = 0.431$

**COMMENT:** Microscale effects could be important, especially for hydrogen at atmospheric pressure and  $T = 300 \text{ K}$ .

## PROBLEM 8.109

**KNOWN:** Chip and cooling channel dimensions. Channel flow rate and inlet temperature. Temperature of chip at base of channel.

**FIND:** (a) Water outlet temperature and chip power, (b) Effect of channel width and pitch on power dissipation.

**SCHEMATIC:**

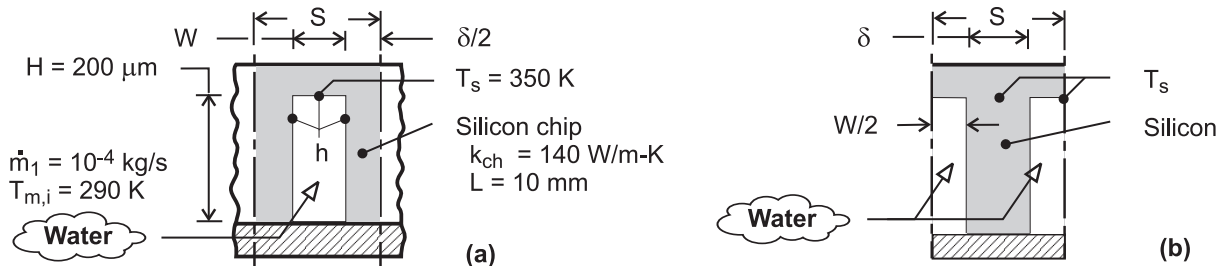

**ASSUMPTIONS:** (1) Incompressible liquid with negligible viscous dissipation, (2) Flow may be approximated as fully developed and channel walls as isothermal for purposes of estimating the convection coefficient, (3) One-dimensional conduction along channel side walls, (4) Adiabatic condition at end of side walls, (5) Heat dissipation is exclusively through fluid flow in channels, (6) Constant properties.

**PROPERTIES:** Table A-6, Water ( $\bar{T}_m = 300\text{K}$ ):  $c_p = 4179\text{ J/kg}\cdot\text{K}$ ,  $\mu = 855 \times 10^{-6}\text{ kg/s}\cdot\text{m}$ ,  $k = 0.613\text{ W/m}\cdot\text{K}$ ,  $Pr = 5.83$ .

**ANALYSIS:** (a) The channel sidewalls act as fins, and a *unit* channel/sidewall combination is shown in schematic (a), where the total number of unit cells corresponds to  $N = L/S$ . With  $N = 50$  and  $L = 10\text{ mm}$ ,  $S = 200\ \mu\text{m}$  and  $\delta = S - W = 150\ \mu\text{m}$ . Alternatively, the unit cell may be represented in terms of a single fin of thickness  $\delta$ , as shown in schematic (b). The thermal resistance of the unit cell may be obtained from the expression for a fin array, Eq. (3.108),  $R_{t,o} = (\eta_o h A_t)^{-1}$ , where  $A_t = A_f + A_b = L(2H + W) = 0.01\text{m}(4 \times 10^{-4} + 0.5 \times 10^{-4})\text{ m} = 4.5 \times 10^{-6}\text{ m}^2$ . With  $D_h = 4(H \times W)/2(H + W) = 4(2 \times 10^{-4}\text{ m} \times 0.5 \times 10^{-4}\text{ m})/2(2.5 \times 10^{-4}\text{ m}) = 8 \times 10^{-5}\text{ m}$ , the Reynolds number is  $Re_D = \rho u_m D_h/\mu = \dot{m}_1 D_h/A_c \mu = 10^{-4}\text{ kg/s} \times 8 \times 10^{-5}\text{ m}/(2 \times 10^{-4}\text{ m} \times 0.5 \times 10^{-4}\text{ m}) 855 \times 10^{-6}\text{ kg/s}\cdot\text{m} = 936$ . Hence, the flow is laminar, and assuming fully developed conditions throughout a channel with uniform surface temperature, Table 8.1 yields  $Nu_D = 4.44$ . Hence,

$$h = \frac{k}{D_h} Nu_D = \frac{0.613\text{ W/m}\cdot\text{K} \times 4.44}{8 \times 10^{-5}\text{ m}} = 34,022\text{ W/m}^2 \cdot \text{K}$$

With  $m = (2h/k_{ch}\delta)^{1/2} = (68,044\text{ W/m}^2 \cdot \text{K}/140\text{ W/m}\cdot\text{K} \times 1.5 \times 10^{-4}\text{ m})^{1/2} = 1800\text{ m}^{-1}$  and  $mH = 0.36$ , the fin efficiency is

$$\eta_f = \frac{\tanh mH}{mH} = \frac{0.345}{0.36} = 0.958$$

and the overall surface efficiency is

$$\eta_o = 1 - \frac{A_f}{A_t}(1 - \eta_f) = 1 - \frac{4.0 \times 10^{-6}}{4.5 \times 10^{-6}}(1 - 0.958) = 0.963$$

The thermal resistance of the unit cell is then

Continued ...

**PROBLEM 8.109 (Cont.)**

$$R_{t,o} = (\eta_o h A_t)^{-1} = \left(0.963 \times 34,022 \text{ W/m}^2 \cdot \text{K} \times 4.5 \times 10^{-6} \text{ m}^2\right)^{-1} = 6.78 \text{ K/W}$$

The outlet temperature follows from Eq. (8.45b),

$$T_{m,o} = T_s - (T_s - T_{m,i}) \exp\left(-\frac{1}{\dot{m}_1 c_p R_{t,o}}\right) = 350\text{K} - (60\text{K}) \times \exp\left(-\frac{1}{10^{-4} \text{ kg/s} \times 4179 \text{ J/kg} \cdot \text{K} \times 6.78 \text{ K/W}}\right) = 307.8\text{K} \quad <$$

The heat rate per channel is then

$$q_1 = \dot{m}_1 c_p (T_{m,o} - T_{m,i}) = 10^{-4} \text{ kg/s} \times 4179 \text{ J/kg} \cdot \text{K} (17.8\text{K}) = 7.46 \text{ W}$$

and the chip power dissipation is

$$q = Nq_1 = 50 \times 7.46 \text{ W} = 373 \text{ W} \quad <$$

(b) The foregoing result indicates significant heat transfer from the channel side walls due to the large value of  $\eta_f$ . If the pitch is reduced by a factor of 2 ( $S = 100 \mu\text{m}$ ), we obtain

$$S = 100 \mu\text{m}, W = 50 \mu\text{m}, \delta = 50 \mu\text{m}, N = 100: q_1 = 7.04 \text{ W}, q = 704 \text{ W} \quad <$$

Hence, although there is a reduction in  $\eta_f$  due to the reduction in  $\delta$  ( $\eta_f = 0.89$ ) and therefore a slight reduction in the value of  $q_1$ , the effect is more than compensated by the increase in the number of channels. Additional benefit may be derived by further reducing the pitch to whatever minimum value of  $\delta$  is imposed by manufacturing or structural limitations. There would also be an advantage to increasing the channel hydraulic diameter and or flowrate, such that turbulent flow is achieved with a correspondingly larger value of  $h$ .

**COMMENTS:** (1) Because electronic devices fail by contact with a polar fluid such as water, great care would have to be taken to hermetically seal the devices from the coolant channels. In lieu of water, a dielectric fluid could be used, thereby permitting contact between the fluid and the electronics. However, all such fluids, such as air, are less effective as coolants. (2) With  $L/D_h = 125$  and  $L/D_h)_{fd} \approx 0.05 \text{ Re}_D \text{ Pr} = 273$ , fully developed flow is not achieved and the value of  $h = h_{fd}$  underestimates the actual value of  $\bar{h}$  in the channel. The coefficient is also underestimated by using a Nusselt number that presumes heat transfer from all four (rather than three) surfaces of a channel.

## PROBLEM 8.110

**KNOWN:** Temperature and pressure of a gas flowing in a circular tube.

**FIND:** The critical tube diameter,  $D_c$ , below which incompressible turbulent flow cannot exist for (a) air (b)  $\text{CO}_2$ , and (c) He.

**SCHEMATIC:**

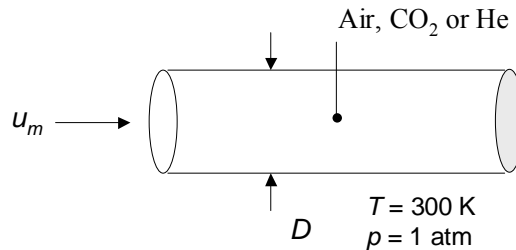

**ASSUMPTIONS:** (1) Ideal gas behavior. (2) Fully-developed flow.

**PROPERTIES:** Table A.4 ( $T = 300 \text{ K}$ ): Air;  $c_p = 1007 \text{ J/kg}\cdot\text{K}$ ,  $\mu = 184.6 \times 10^{-7} \text{ N}\cdot\text{s/m}^2$ .  $\text{CO}_2$ ;  $c_p = 851 \text{ J/kg}\cdot\text{K}$ ,  $\mu = 149 \times 10^{-7} \text{ N}\cdot\text{s/m}^2$ . He;  $c_p = 5193 \text{ J/kg}\cdot\text{K}$ ,  $\mu = 199 \times 10^{-7} \text{ N}\cdot\text{s/m}^2$ . Figure 2.8: Air;  $\mathcal{M} = 28.97 \text{ kg/kmol}$ .  $\text{CO}_2$ ;  $\mathcal{M} = 44.01 \text{ kg/kmol}$  He;  $\mathcal{M} = 4.003 \text{ kg/kmol}$ .

**ANALYSIS:** The relationship  $Re_{D,c} = u_m D / \nu \approx 2300$  may be plotted on a *log-log* scale, as shown in the figure below. Laminar flow occurs to the left of the sloped line, while turbulent flow occurs to the right of the line. The critical Mach number  $Ma_c = u_m / a \approx 0.3$  is drawn as the horizontal line that separates regions of incompressible flow (below the line) and compressible flow (above the line). It is evident that below a critical diameter,  $D_c$ , turbulent incompressible flow and heat transfer cannot exist.

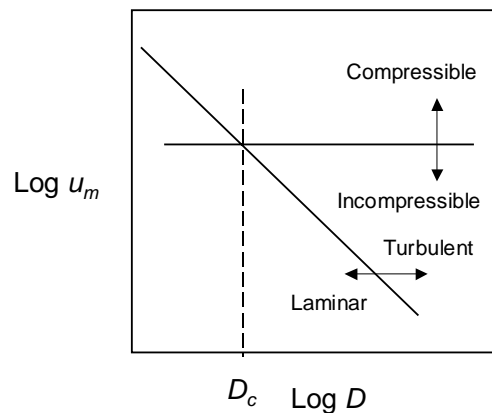

(a) From the ideal gas equation of state,

$$\rho = p/RT \quad (1)$$

and from Section 6.4.2 the speed of sound is

$$a = \sqrt{\gamma RT} \quad (2)$$

Continued...

### PROBLEM 8.110 (Cont.)

where  $\gamma \equiv c_p/c_v$  is the ratio of specific heats. The mean velocity may be related to the Mach number,  $Ma$ , and is

$$u_m = Ma \cdot a \quad (3)$$

Combining the preceding equations yields

$$Re = \frac{Ma \cdot p}{\mu} \sqrt{\frac{\gamma}{RT}} D \quad (4)$$

Specifying  $Re = Re_c$  and  $Ma = Ma_c$  leads to the following expression for the critical tube diameter

$$D_c = \frac{Re_c}{Ma_c} \sqrt{\frac{RT}{\gamma}} \frac{\mu}{p} \quad (5)$$

For air, the ideal gas constant, specific heat at constant volume, and ratio of specific heats are

$$R = \frac{\mathcal{R}}{\mathcal{M}} = \frac{8.315 \text{ kJ/kmol} \cdot \text{K}}{28.97 \text{ kg/kmol}} = 0.287 \frac{\text{kJ}}{\text{kg} \cdot \text{K}};$$

$$c_v = c_p - R = 1.007 \frac{\text{kJ}}{\text{kg} \cdot \text{K}} - 0.287 \frac{\text{kJ}}{\text{kg} \cdot \text{K}} = 0.720 \frac{\text{kJ}}{\text{kg} \cdot \text{K}}; \quad \gamma = \frac{c_p}{c_v} = \frac{1.007}{0.720} = 1.399$$

Therefore,

$$D_c = \frac{2300}{0.3} \sqrt{\frac{287 \text{ J/kg} \cdot \text{K} \times 300 \text{ K}}{1.399}} \times \frac{184.6 \times 10^{-7} \text{ N} \cdot \text{s/m}^2}{1.0133 \times 10^5 \text{ N/m}^2} = 346 \times 10^{-6} \text{ m} = 0.346 \text{ mm} \quad <$$

(b,c) The calculations may be repeated for CO<sub>2</sub> and He, yielding the following results.

Gas	$R$ (kJ/kg·K)	$c_v$ (kJ/kg·K)	$\gamma$	$D_c$ (mm)	
CO <sub>2</sub>	0.189	0.662	1.285	0.237	<
He	2.077	3.116	1.667	0.920	<

**COMMENTS:** (1) Below the critical diameter,  $D_c$ , the effects of compressibility must *always* be accounted for if the flow is turbulent, and are *often* important if the flow is laminar. Because the correlations of Chapter 8 do not account for the effects of compressibility, they may not be applied to situations where turbulence exists and the tube diameter is less than  $D_c$ . The correlations must be used with caution if the flow is laminar and  $D < D_c$  since compressibility effects might be important. (2) The critical diameter is moderately dependent on the specific gas of interest, for the three gases considered here.

## PROBLEM 8.111

**KNOWN:** Chip and cooling channel dimensions. Channel flow rate and inlet temperature. Temperature of chip at base of channel.

**FIND:** (a) Outlet temperature and chip power dissipation for dielectric liquid, (b) Outlet temperature and chip power dissipation for air.

**SCHEMATIC:**

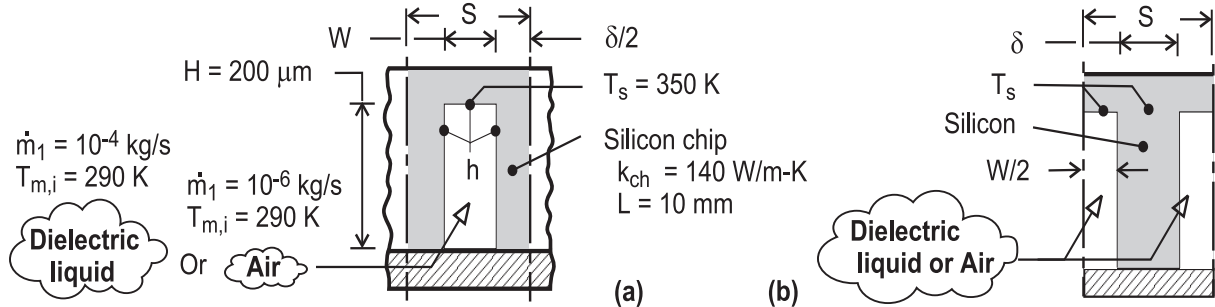

**ASSUMPTIONS:** (1) Applicability of Eq. 8.34, (2) Flow may be approximated as fully developed and channel walls as isothermal for purposes of estimating the convection coefficient, (3) One-dimensional conduction along the channel side walls, (4) Adiabatic condition at end of side walls, (5) Heat dissipation is exclusively through fluid flow in channels, (6) Constant properties.

**PROPERTIES:** Prescribed. Dielectric liquid:  $c_p = 1050 \text{ J/kg}\cdot\text{K}$ ,  $k = 0.065 \text{ W/m}\cdot\text{K}$ ,  $\mu = 0.0012 \text{ N}\cdot\text{s/m}^2$ ,  $\text{Pr} = 15$ . Air:  $c_p = 1007 \text{ J/kg}\cdot\text{K}$ ,  $k = 0.0263 \text{ W/m}\cdot\text{K}$ ,  $\mu = 185 \times 10^{-7} \text{ N}\cdot\text{s/m}^2$ ,  $\text{Pr} = 0.707$ .

**ANALYSIS:** (a) The channel side walls act as fins, and a *unit* channel/sidewall combination is shown in schematic (a), where  $\delta = S - W = 150 \mu\text{m}$ . Alternatively, the unit cell may be represented in terms of a single fin of thickness  $\delta$ , as shown in schematic (b). The thermal resistance of the unit cell may be obtained from the expression for a fin array, Eq. (3.108),  $R_{t,o} = (\eta_o h A_t)^{-1}$ , where  $A_t = A_f + A_b = L (2H + W) = 4.5 \times 10^{-6} \text{ m}^2$ . With  $A_c = H \times W = 10^{-8} \text{ m}^2$  and  $D_h = 4 A_c / (2H + W) = 8 \times 10^{-5} \text{ m}$ , the Reynolds number is  $\text{Re}_D = \rho u_m D_h / \mu = \dot{m}_1 D_h / A_c \mu = 667$ . Hence, the flow is laminar, and assuming fully developed conditions throughout a channel with uniform surface temperature, Table 8.1 yields

$$\text{Nu}_D = 4.44. \text{ Hence, } h = \frac{k}{D_h} \text{Nu}_D = \frac{0.065 \text{ W/m}\cdot\text{K} \times 4.44}{8 \times 10^{-5} \text{ m}} = 3608 \text{ W/m}^2 \cdot \text{K}$$

With  $m = (2h/k_{ch}\delta)^{1/2} = 586 \text{ m}^{-1}$  and  $mH = 0.117$ , the fin efficiency is

$$\eta_f = \frac{\tanh mH}{mH} = \frac{0.1167}{0.117} = 0.995$$

and the overall surface efficiency is

$$\eta_o = 1 - \frac{A_f}{A_t} (1 - \eta_f) = 1 - \frac{4.0 \times 10^{-6}}{4.5 \times 10^{-6}} (1 - 0.995) = 0.996.$$

The thermal resistance of the unit cell is then

$$R_{t,o} = (\eta_o h A_t)^{-1} = \left( 0.996 \times 3608 \text{ W/m}^2 \cdot \text{K} \times 4.5 \times 10^{-6} \text{ m}^2 \right)^{-1} = 61.9 \text{ K/W}$$

The outlet temperature follows from Eq. (8.45b),

$$T_{m,o} = T_s - (T_s - T_{m,i}) \exp \left( -\frac{1}{\dot{m}_1 c_p R_{t,o}} \right) = 350 \text{ K}$$

Continued ...

**PROBLEM 8.111 (Cont.)**

$$-(60\text{K}) \exp\left(-\frac{1}{10^{-4} \text{ kg/s} \times 1050 \text{ J/kg} \cdot \text{K} \times 61.9 \text{ K/W}}\right) = 298.6\text{K} \quad <$$

The heat rate per channel is then

$$q_1 = \dot{m}_1 c_p (T_{m,o} - T_{m,i}) = 10^{-4} \text{ kg/s} \times 1050 \text{ J/kg} \cdot \text{K} \times 8.6 \text{ K} = 0.899 \text{ W}$$

and the chip power dissipation is

$$q = Nq_1 = 50 \times 0.899 \text{ W} = 45.0 \text{ W} \quad <$$

(b) With  $\dot{m}_1 = 10^{-6} \text{ kg/s}$ ,  $\text{Re}_D = \dot{m}_1 D_h / A_c \mu = 432$  and the flow is laminar. Hence, with  $\text{Nu}_D = 4.44$ ,

$$h = \frac{k}{D_h} \text{Nu}_D = \frac{0.0263 \text{ W/m} \cdot \text{K} \times 4.44}{8 \times 10^{-5} \text{ m}} = 1460 \text{ W/m}^2 \cdot \text{K}$$

With  $m = (2h/k_{ch}\delta)^{1/2} = 373 \text{ m}^{-1}$  and  $mH = 0.0746$ , the fin efficiency is

$$\eta_f = \frac{\tanh mH}{mH} = \frac{0.0744}{0.0746} = 0.998$$

and the overall surface efficiency is

$$\eta_o = 1 - \frac{A_f}{A_t} (1 - \eta_f) = 1 - \frac{4.0 \times 10^{-6}}{4.5 \times 10^{-6}} (1 - 0.998) = 0.998$$

Hence,  $R_{t,o} = (\eta_o h A_t)^{-1} = \left(0.998 \times 1460 \text{ W/m}^2 \cdot \text{K} \times 4.5 \times 10^{-6} \text{ m}^2\right)^{-1} = 153 \text{ K/W}$

The outlet temperature is then

$$T_{m,o} = T_s - (T_s - T_{m,i}) \exp\left(-\frac{1}{\dot{m}_1 c_p R_{t,o}}\right) = 350\text{K}$$

$$-(60\text{K}) \exp\left(-\frac{1}{10^{-6} \text{ kg/s} \times 1007 \text{ J/kg} \cdot \text{K} \times 153 \text{ K/W}}\right) = 349.9 \text{ K} \quad <$$

$$q_1 = \dot{m}_1 c_p (T_{m,o} - T_{m,i}) = 10^{-6} \text{ kg/s} \times 1007 \text{ J/kg} \cdot \text{K} \times 59.9 \text{ K} = 0.060 \text{ W}$$

$$q = Nq_1 = 3.02 \text{ W} \quad <$$

**COMMENTS:** (1) For laminar flow in the channels, there is a clear advantage to using the dielectric liquid instead of air. (2) The prescribed channel geometry is by no means optimized, and the number of fins should be increased by reducing  $S$ . Also, channel dimensions and/or flow rates could be increased to achieve turbulent flow and hence much larger values of  $h$ . (3) With  $L/D_h = 125$  and  $(L/D_h)_{fd} \approx 0.05 \text{ Re}_D \text{ Pr} = 500$  for the dielectric liquid, fully developed flow is not achieved and its assumption yields a conservative (under) estimate of the convection coefficient. The coefficient is also underestimated by using a Nusselt number that presumes heat transfer from all four (rather than three) surfaces of a channel.

## PROBLEM 8.112

**KNOWN:** Temperature and pressure of air flowing in a circular tube of known diameter. Thermal and momentum accommodation coefficients. Fully developed laminar flow with constant heat flux.

**FIND:** Graph of the Nusselt number versus tube diameter for  $1 \mu\text{m} \leq D \leq 1 \text{ mm}$  and (a)  $\alpha_t = 1$ ,  $\alpha_p = 1$ , (b)  $\alpha_t = 0.1$ ,  $\alpha_p = 0.1$ , (c)  $\alpha_t = 1$ ,  $\alpha_p = 0.1$  and (d)  $\alpha_t = 0.1$ ,  $\alpha_p = 1$ .

**SCHEMATIC:**

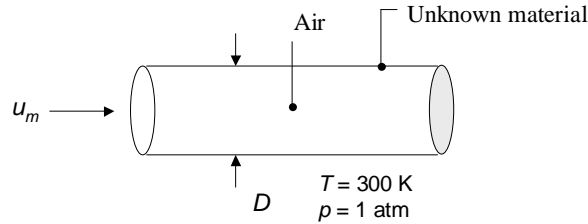

**ASSUMPTIONS:** (1) Ideal gas behavior. (2) Fully-developed laminar flow.

**PROPERTIES:** Table A.4 ( $T = 300 \text{ K}$ ): Air;  $c_p = 1007 \text{ J/kg}\cdot\text{K}$ ,  $Pr = 0.707$ . Figure 2.8: Air;  $\mathcal{M} = 28.97 \text{ kg/kmol}$ ,  $d = 0.372 \times 10^{-9} \text{ m}$ .

**ANALYSIS:** The ideal gas constant, specific heat at constant volume, and ratio of specific heats are:

$$R = \frac{\mathcal{R}}{\mathcal{M}} = \frac{8.315 \text{ kJ/kmol}\cdot\text{K}}{28.97 \text{ kg/kmol}} = 0.287 \frac{\text{kJ}}{\text{kg}\cdot\text{K}};$$

$$c_v = c_p - R = 1007 \frac{\text{kJ}}{\text{kg}\cdot\text{K}} - 0.287 \frac{\text{kJ}}{\text{kg}\cdot\text{K}} = 0.720 \frac{\text{kJ}}{\text{kg}\cdot\text{K}}; \quad \gamma = \frac{c_p}{c_v} = \frac{1.007}{0.720} = 1.399$$

From Equation 2.11 the mean free path of air is

$$\lambda_{\text{mfp}} = \frac{k_B T}{\sqrt{2} \pi d^2 p} = \frac{1.381 \times 10^{-23} \text{ J/K} \times 300 \text{ K}}{\sqrt{2} \pi (0.372 \times 10^{-9} \text{ m})^2 (1.0133 \times 10^5 \text{ N/m}^2)} = 66.5 \times 10^{-9} \text{ m} = 66.5 \text{ nm}$$

From Equation 8.78, the Nusselt number may be expressed as

$$Nu_D = \frac{hD}{k} = \frac{48}{11 - 6\zeta + \zeta^2 + 48\Gamma_t} \quad (1)$$

where

$$\Gamma_t = \frac{2 - \alpha_t}{\alpha_t} \frac{2\gamma}{\gamma + 1} \left[ \frac{\lambda_{\text{mfp}}}{PrD} \right] \quad (2)$$

Continued...



### PROBLEM 8.112 (Cont.)

$$\Gamma_p = \frac{2 - \alpha_p}{\alpha_p} \left[ \frac{\lambda_{\text{mf}}}{D} \right] \quad (3)$$

$$\zeta = \frac{8\Gamma_p}{(1 + 8\Gamma_p)} \quad (4)$$

Equations 1 through 4 may be combined to yield the following graph that shows the variation of the Nusselt number over the tube diameter range  $1 \mu\text{m} \leq D \leq 1000 \mu\text{m}$ .

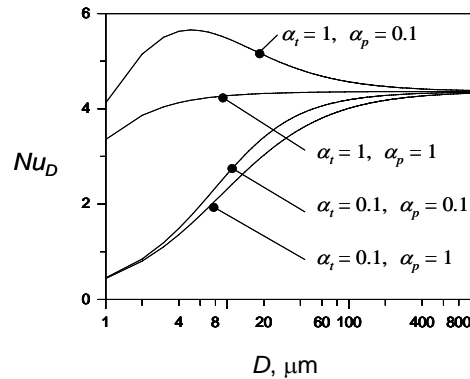

The accommodation coefficients begin to influence the Nusselt number (and hence the convection heat transfer coefficient) at diameters less than approximately  $400 \mu\text{m}$ .

The Nusselt number is least sensitive to changes in the tube diameter for  $\alpha_i = \alpha_p = 1$ .

The Nusselt number can exceed 4.36 when the momentum accommodation coefficient is small and the thermal accommodation coefficient is large.

Small values of the thermal accommodation coefficient in conjunction with large values of the momentum accommodation coefficient result in the most significant reductions in the Nusselt number.

The Nusselt number can increase or decrease relative to the value associated with conventional flows, and the change in the Nusselt number can be quite large. Hence prediction of convection heat transfer coefficients in nano- and some microscale devices involving gas flow is typically subject to a high degree of uncertainty.

**Comment:** Thermal accommodation coefficients can be of very small value, as discussed in Chapter 3.

### PROBLEM 8.113

**KNOWN:** Arrangement of chips and cooling channels for a substrate. Contact and conduction resistances. Coolant velocity and inlet temperature.

**FIND:** (a) Coolant temperature rise, (b) Chip and substrate temperatures.

**SCHEMATIC:**

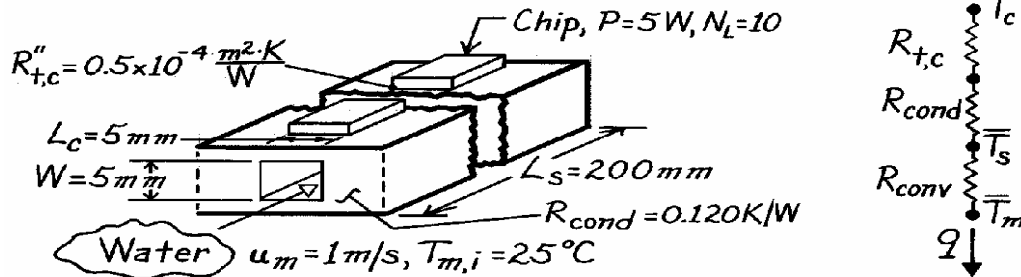

**ASSUMPTIONS:** (1) Constant properties, (2) Fully-developed flow, (3) Incompressible liquid with negligible viscous dissipation, (4) Heat transfer exclusively to water, (5) Steady-state conditions.

**PROPERTIES:** Water (given):  $\rho = 1000 \text{ kg/m}^3$ ,  $c_p = 4180 \text{ J/kg}\cdot\text{K}$ ,  $k = 0.610 \text{ W/m}\cdot\text{K}$ ,  $Pr = 5.8$ ,  $\mu = 855 \times 10^{-6} \text{ kg/s}\cdot\text{m}$ .

**ANALYSIS:** (a) For a single flow channel, the overall energy balance yields

$$T_{m,o} - T_{m,i} = \frac{q}{\dot{m} c_p} = \frac{N_L P}{\rho u_m A_c c_p} = \frac{10 \times 5 \text{ W}}{1000 \text{ kg/m}^3 (1 \text{ m/s}) (0.005 \text{ m})^2 4180 \text{ J/kg}\cdot\text{K}} = 0.48^\circ\text{C} \quad <$$

From the thermal circuit,

$$q = \frac{T_o - \bar{T}_m}{R_{t,c} + R_{cond} + R_{conv}} \quad R_{t,c} = R''_{t,c} / A_s = (0.5 \times 10^{-4} \text{ m}^2 \cdot \text{K/W}) / 10 (0.005 \text{ m})^2 = 0.2 \text{ K/W}.$$

With  $D_h = 4A_c/P = 4(0.005 \text{ m})^2 / 4(0.005 \text{ m}) = 0.005 \text{ m}$ ,

$$Re_D = \frac{\rho u_m D_h}{\mu} = \frac{1000 \text{ kg/m}^3 (1 \text{ m/s}) 0.005 \text{ m}}{855 \times 10^{-6} \text{ kg/s}\cdot\text{m}} = 5848.$$

With turbulent flow, the Gnielinski correlation yields

$$h = \frac{k}{D} \frac{(f/8)(Re_D - 1000) Pr}{1 + 12.7(f/8)^{1/2}(Pr^{2/3} - 1)} = \frac{0.61 \text{ W/m}\cdot\text{K}}{0.005 \text{ m}} \frac{(0.0368/8)(5848 - 1000) 5.8}{1 + 12.7(0.0368/8)^{1/2}(5.8^{2/3} - 1)} = 5406 \text{ W/m}^2 \cdot \text{K}$$

where  $f = (0.79 \ln Re_D - 1.64)^{-2} = 0.0368$ .

$$R_{conv} = (h A_s)^{-1} = (5406 \text{ W/m}^2 \cdot \text{K} \times 4 \times 0.005 \text{ m} \times 0.2 \text{ m})^{-1} = 0.046 \text{ K/W}.$$

Approximating  $T_m$  as  $(T_{m,i} + T_{m,o})/2 = 25.24^\circ\text{C}$ ,

$$\bar{T}_c = \bar{T}_m + q(R_{t,c} + R_{cond} + R_{conv}) = 25.24^\circ\text{C} + 50 \text{ W} (0.2 + 0.12 + 0.046) \text{ K/W} = 43.6^\circ\text{C} \quad <$$

Similarly, from the thermal circuits,

$$\bar{T}_s = \bar{T}_m + q \times R_{conv} = 25.24^\circ\text{C} + 50 \text{ W} \times 0.046 \text{ K/W} = 27.6^\circ\text{C} \quad <$$

**COMMENTS:** (1) Since the coolant temperature rise is less than  $0.5^\circ\text{C}$ , all chip temperatures will be within  $0.5^\circ\text{C}$  of each other. (2) The channel surface temperature may also be obtained from Eq. 8.41b, yielding the same result.

## PROBLEM 8.114

**KNOWN:** Temperature and pressure of a gas flowing in a circular tube of known diameter with constant surface heat flux. Thermal and momentum accommodation coefficients. Fully developed laminar flow.

**FIND:** Graph of the Nusselt number for tube diameters of  $1 \mu\text{m} \leq D \leq 1 \text{ mm}$ .

**SCHEMATIC:**

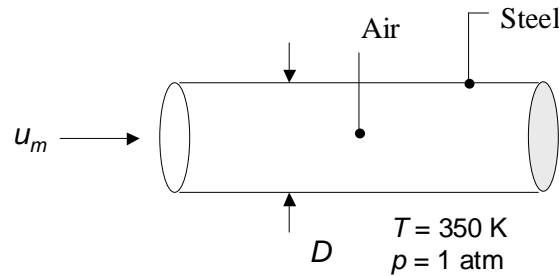

**ASSUMPTIONS:** (1) Ideal gas behavior. (2) Fully-developed laminar flow.

**PROPERTIES:** Table A.4 ( $T = 350 \text{ K}$ ): Air;  $c_p = 1009 \text{ J/kg}\cdot\text{K}$ ,  $k = 0.030 \text{ W/m}\cdot\text{K}$ ,  $Pr = 0.70$ . Figure 2.8: Air;  $\mathcal{M} = 28.97 \text{ kg/kmol}$ ,  $d = 0.372 \times 10^{-9} \text{ m}$ .

**ANALYSIS:** The ideal gas constant, specific heat at constant volume, and ratio of specific heats are:

$$R = \frac{\mathcal{R}}{\mathcal{M}} = \frac{8.315 \text{ kJ/kmol}\cdot\text{K}}{28.97 \text{ kg/kmol}} = 0.287 \frac{\text{kJ}}{\text{kg}\cdot\text{K}};$$

$$c_v = c_p - R = 1.009 \frac{\text{kJ}}{\text{kg}\cdot\text{K}} - 0.287 \frac{\text{kJ}}{\text{kg}\cdot\text{K}} = 0.722 \frac{\text{kJ}}{\text{kg}\cdot\text{K}}; \quad \gamma = \frac{c_p}{c_v} = \frac{1.009}{0.722} = 1.398$$

From Equation 2.11 the mean free path of air is

$$\lambda_{\text{mfp}} = \frac{k_B T}{\sqrt{2} \pi d^2 p} = \frac{1.381 \times 10^{-23} \text{ J/K} \times 350 \text{ K}}{\sqrt{2} \pi (0.372 \times 10^{-9} \text{ m})^2 (1.0133 \times 10^5 \text{ N/m}^2)} = 77.6 \times 10^{-9} \text{ m} = 77.6 \text{ nm}$$

From Equation 8.78 the Nusselt number may be expressed as

$$Nu_D = \frac{hD}{k} = \frac{48}{11 - 6\zeta + \zeta^2 + 48\Gamma_t} \quad (1)$$

where

Continued...

**PROBLEM 8.114 (Cont.)**

$$\Gamma_t = \frac{2 - \alpha_t}{\alpha_t} \frac{2\gamma}{\gamma + 1} \left[ \frac{\lambda_{\text{mf}}}{PrD} \right] = \frac{2 - 0.92}{0.92} \cdot \frac{2 \times 1.398}{1.398 + 1} \left[ \frac{77.6 \times 10^{-9} \text{ m}}{0.700D} \right] = \frac{152 \times 10^{-9} \text{ m}}{D} \quad (2)$$

$$\Gamma_p = \frac{2 - \alpha_p}{\alpha_p} \left[ \frac{\lambda_{\text{mf}}}{D} \right] = \frac{2 - 0.87}{0.87} \cdot \left[ \frac{77.6 \times 10^{-9} \text{ m}}{D} \right] = \frac{101 \times 10^{-9} \text{ m}}{D} \quad (3)$$

$$\zeta = \frac{8\Gamma_p}{(1 + 8\Gamma_p)} \quad (4)$$

Equations 1 through 4 may be combined to yield the following graph that shows the variation of the Nusselt number over the tube diameter range  $1 \mu\text{m} \leq D \leq 1000 \mu\text{m}$ .

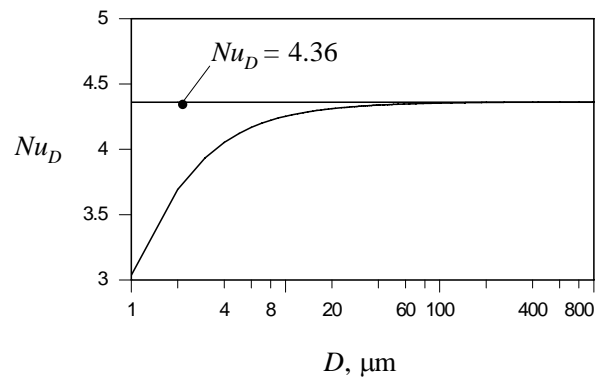

**COMMENTS:** (1) The Nusselt number begins to be affected by the tube dimension at a tube diameter of  $D \approx 100 \mu\text{m}$ . (2) Equation 8.78 is associated with constant heat flux conditions. We would expect a similar reduction in Nusselt numbers for constant temperature wall conditions.

## PROBLEM 8.115

**KNOWN:** Inner diameter of microscale tube, wall thickness of tube, temperature of water inside the tube, and temperature of water in cross flow over the tube.

**FIND:** (a) Required tube length at  $Re_D = 2000$ , (b) Water outlet temperature, (c) Pressure drop associated with the flow of water inside the tube, (d) Height of water column needed to supply the required inlet pressure and time needed to collect 0.1 liter of water. Discuss measurement of outlet water temperature.

**SCHEMATIC:**

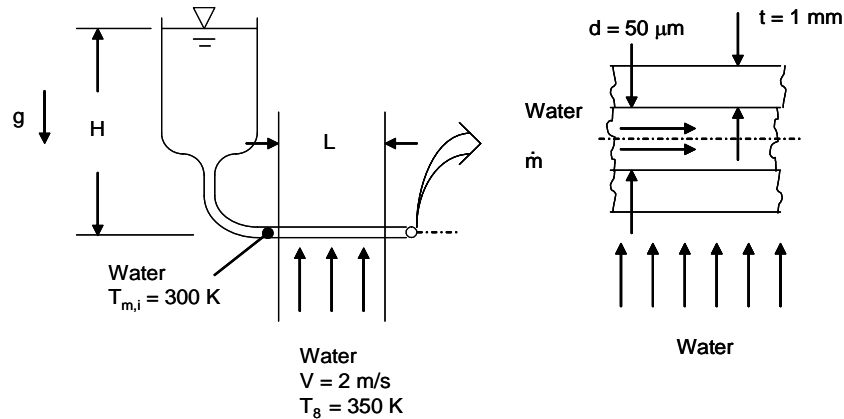

**ASSUMPTIONS:** (1) Constant properties and steady-state conditions, (2) Incompressible liquid and negligible viscous dissipation, (3) Negligible microscale or nanoscale effects.

**PROPERTIES:** Table A.6, water: ( $\bar{T}_m = 305$  K):  $k = 0.620$  W/m·K,  $c_p = 4178$  J/kg·K,  $\mu = 769 \times 10^{-6}$  N·s/m<sup>2</sup>,  $Pr = 5.2$ ,  $\rho = 995$  kg/m<sup>3</sup>; ( $\bar{T} = 330$  K):  $k = 0.650$  W/m·K,  $c_p = 4194$  J/kg·K,  $\mu = 489 \times 10^{-6}$  N·s/m<sup>2</sup>,  $Pr = 3.15$ ,  $\rho = 984$  kg/m<sup>3</sup>. Table A.3 glass:  $k = 1.4$  W/m·K.

**ANALYSIS:** (a) At  $Re_D = 2000$ , Equation 8.3 yields  $x_{fd,h} = 0.05Re_DPrD = 0.05 \times 2000 \times 5.2 \times 50 \times 10^{-6}$  m =  $26 \times 10^{-3}$  m. Therefore,  $L = 2x_{fd,h} = 2 \times 26 \times 10^{-3}$  m =  $52 \times 10^{-3}$  m = 52 mm. <

(b) Equation 8.45a is

$$\frac{T_{\infty} - T_{m,o}}{T_{\infty} - T_{m,i}} = \exp\left(-\frac{\bar{U}A_s}{\dot{m}c_p}\right) \quad (1)$$

where we will use  $\bar{U} = \bar{U}_i$ ,  $A_s = A_{s,i}$ . Note that  $Re_D = 4\dot{m}/(\pi D\mu)$  so that  $\dot{m} = Re_D \pi D\mu / 4 = 2000 \times \pi \times 50 \times 10^{-6}$  m  $\times 769 \times 10^{-6}$  N·s/m<sup>2</sup>/4 =  $60.4 \times 10^{-6}$  kg/s. Therefore,  $u_m = \dot{m}/(\rho A_c) = 60.4 \times 10^{-6}$  kg/s  $\times 4 / (995$  kg/m<sup>3</sup>  $\times \pi \times (50 \times 10^{-6}$  m)<sup>2</sup>) = 31 m/s. From Equation 3.36,

Continued...

**PROBLEM 8.115 (Cont.)**

$$\bar{U}_i = \frac{1}{\frac{1}{h_i} + \frac{d/2}{k_g} \ln \left[ \frac{(d/2+t)}{d/2} \right] + \frac{d/2}{(d/2+t)} \frac{1}{h_o}} \quad (2)$$

$A_{s,i} = \pi dL = \pi \times 50 \times 10^{-6} \text{ m} \times 52 \times 10^{-3} \text{ m} = 8.17 \times 10^{-6} \text{ m}^2$ . From Equation 8.56,

$$\bar{Nu}_D = 3.66 + \frac{0.0668(50 \times 10^{-6} / 53 \times 10^{-3}) \times 2000 \times 5.3}{1 + 0.04 \left[ (50 \times 10^{-6} / 53 \times 10^{-3}) \times 2000 \times 5.3 \right]^{2/3}} = 4.371$$

and  $\bar{h}_D = h_i = \bar{Nu}_D \frac{k}{D} = 4.371 \times 0.620 \text{ W/m} \cdot \text{K} / 50 \times 10^{-6} \text{ m} = 54.2 \times 10^3 \text{ W/m}^2 \cdot \text{K}$ .

For the cross flow of water over the tube,  $Re_D = VD\rho/\mu = 2 \text{ m/s} \times (50 \times 10^{-6} \text{ m} + 2 \times 1 \times 10^{-3} \text{ m})(984 \text{ kg/m}^3)/489 \times 10^{-6} \text{ N}\cdot\text{s/m}^2 = 8253$ . From Equation 7.54,

$$\bar{Nu}_D = 0.3 + \frac{0.62(8253)^{1/2}(3.15)^{1/3}}{\left[ 1 + (0.4/3.15)^{2/3} \right]^{1/4}} \left[ 1 + \left( \frac{8253}{282,000} \right)^{5/8} \right]^{4/5} = 85.14$$

and

$$\bar{h}_D = h_o = \bar{Nu}_D k / (d + 2t) = 85.14 \times 0.65 \text{ W/m} \cdot \text{K} / (50 \times 10^{-6} \text{ m} + 2 \times 1 \times 10^{-3} \text{ m}) = 27.0 \times 10^3 \text{ W/m}^2 \cdot \text{K}$$

Therefore,

$$\bar{U}_i = \frac{1}{\left[ \frac{1}{54.2 \times 10^3 \text{ W/m} \cdot \text{K}} + \frac{50 \times 10^{-6} \text{ m}/2}{1.4 \text{ W/m} \cdot \text{K}} \ln \left[ \frac{(50 \times 10^{-6} \text{ m}/2 + 1 \times 10^{-3} \text{ m})}{50 \times 10^{-6} \text{ m}/2} \right] \right] + \frac{50 \times 10^{-6} \text{ m}/2}{(50 \times 10^{-6} \text{ m}/2 + 1 \times 10^{-3} \text{ m})} \times \frac{1}{27.0 \times 10^3 \text{ W/m}^2 \cdot \text{K}}} = 11.7 \times 10^3 \text{ W/m}^2 \cdot \text{K}$$

Equation (1) becomes

$$\frac{350\text{K} - T_{m,o}}{350\text{K} - 300\text{K}} = \exp \left( - \frac{11.7 \times 10^3 \text{ W/m}^2 \cdot \text{K} \times 8.17 \times 10^{-6} \text{ m}^2}{60.4 \times 10^{-6} \text{ kg/s} \cdot 4194 \text{ J/kg} \cdot \text{K}} \right)$$

or,  $T_{m,o} = 316 \text{ K}$

<  
Continued...

### PROBLEM 8.115 (Cont.)

(c) For laminar flow, Equation 8.19 yields  $f = 64/\text{Re}_D = 64/2000 = 32 \times 10^{-3}$ . Equation 8.22a yields

$$\Delta p = f \frac{\rho u_m^2}{2D} L = \frac{32 \times 10^{-3} \times 995 \text{ kg/m}^3 \times (31 \text{ m/s})^2 \times 52 \times 10^{-3} \text{ m}}{2(50 \times 10^{-6} \text{ m})} = 15.9 \times 10^6 \text{ Pa} \quad <$$

(d) The pressure generated by the water column must offset the pressure drop in the tube. Therefore,

$$\rho g H = \Delta p \quad \text{or} \quad H = \Delta p / \rho g = 15.9 \times 10^6 \text{ N/m}^2 / (995 \text{ kg/m}^3 \times 9.8 \text{ m/s}^2) = 1630 \text{ m} = 1.63 \text{ km} \quad <$$

The time required for a particular volume of water to flow through the system is

$$t = \frac{V\rho}{m} = \frac{0.1 \times \frac{1 \text{ m}^3}{1000 \text{ ml}} \times 995 \text{ kg/m}^3}{60.4 \times 10^{-6} \text{ kg/s}} = 1650 \text{ s} \quad <$$

**COMMENTS:** (1) Microscale experimentation is often very difficult to perform. In addition to the difficulty in measuring the water outlet temperature, establishing a constant flow rate with such a large inlet pressure would be very difficult. (2) Turbulent conditions in microscale systems are rare in nature, and are difficult to achieve experimentally. (3) The glass tube wall is relatively thick. Therefore, conduction in the axial direction is likely to be significant. (4) The average mean water temperature inside the tube is  $\bar{T}_m = (T_{m,i} + T_{m,o})/2 = (300 \text{ K} + 316 \text{ K})/2 = 308 \text{ K}$ . The assumed mean temperature of 305 K is good.

## PROBLEM 8.116

**KNOWN:** Temperature and pressure of air flowing in a circular tube or between parallel plates. Thermal and momentum accommodation coefficients.

**FIND:** Tube diameter  $D$  and plate spacing  $a$  that correspond to a 10 percent reduction in the Nusselt number.

**SCHEMATIC:**

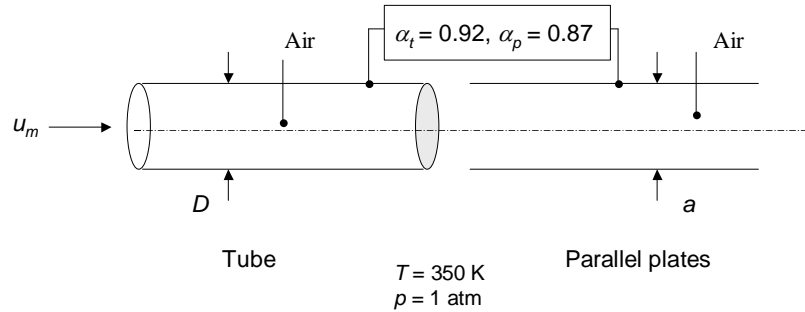

**ASSUMPTIONS:** (1) Ideal gas behavior. (2) Fully-developed laminar flow.

**PROPERTIES:** Table A.4 ( $T = 350 \text{ K}$ ): Air;  $c_p = 1009 \text{ J/kg}\cdot\text{K}$ ,  $Pr = 0.70$ . Figure 2.8: Air;  $\mathcal{M} = 28.97 \text{ kg/kmol}$ ,  $d = 0.372 \times 10^{-9} \text{ m}$ .

**ANALYSIS:** The ideal gas constant, specific heat at constant volume, and ratio of specific heats are:

$$R = \frac{\mathcal{R}}{\mathcal{M}} = \frac{8.315 \text{ kJ/kmol}\cdot\text{K}}{28.97 \text{ kg/kmol}} = 0.287 \frac{\text{kJ}}{\text{kg}\cdot\text{K}};$$

$$c_v = c_p - R = 1.009 \frac{\text{kJ}}{\text{kg}\cdot\text{K}} - 0.287 \frac{\text{kJ}}{\text{kg}\cdot\text{K}} = 0.722 \frac{\text{kJ}}{\text{kg}\cdot\text{K}}; \quad \gamma = \frac{c_p}{c_v} = \frac{1.009}{0.722} = 1.398$$

From Equation 2.11 the mean free path of air is

$$\lambda_{\text{mfp}} = \frac{k_B T}{\sqrt{2} \pi d^2 p} = \frac{1.381 \times 10^{-23} \text{ J/K} \times 350 \text{ K}}{\sqrt{2} \pi (0.372 \times 10^{-9} \text{ m})^2 (1.0133 \times 10^5 \text{ N/m}^2)} = 77.6 \times 10^{-9} \text{ m} = 77.6 \text{ nm}$$

From Equation 8.78 the Nusselt number for the tube may be expressed as

$$Nu_D = \frac{48}{11 - 6\zeta + \zeta^2 + 48\Gamma_t} = 0.9 \times 4.36 = 3.92 \quad (1)$$

where

$$\Gamma_t = \frac{2 - \alpha_t}{\alpha_t} \frac{2\gamma}{\gamma + 1} \left[ \frac{\lambda_{\text{mfp}}}{PrD} \right] = \frac{2 - 0.92}{0.92} \cdot \frac{2 \times 1.398}{1.398 + 1} \left[ \frac{77.6 \times 10^{-9} \text{ m}}{0.700D} \right] = \frac{152 \times 10^{-9} \text{ m}}{D} \quad (2)$$

Continued...



**PROBLEM 8.116 (Cont.)**

$$\Gamma_p = \frac{2 - \alpha_p}{\alpha_p} \left[ \frac{\lambda_{\text{mfp}}}{D} \right] = \frac{2 - 0.87}{0.87} \cdot \left[ \frac{77.6 \times 10^{-9} \text{ m}}{D} \right] = \frac{101 \times 10^{-9} \text{ m}}{D} \quad (3)$$

$$\zeta = \frac{8\Gamma_p}{(1 + 8\Gamma_p)} \quad (4)$$

Equations 1 through 4 may be solved by trial-and-error to yield  $D = 2.94 \times 10^{-6} \text{ m} = 2.94 \text{ }\mu\text{m}$ . <

From Equation 8.79 the Nusselt number for the parallel plate configuration may be expressed as

$$Nu_D = \frac{140}{17 - 6\zeta + (2/3)\zeta^2 + 70\Gamma_t} = 0.9 \times 8.23 = 7.41 \quad (5)$$

where

$$\Gamma_t = \frac{2 - \alpha_t}{\alpha_t} \frac{2\gamma}{\gamma + 1} \left[ \frac{\lambda_{\text{mfp}}}{PrD_h} \right] = \frac{2 - 0.92}{0.92} \cdot \frac{2 \times 1.398}{1.398 + 1} \left[ \frac{77.6 \times 10^{-9} \text{ m}}{0.700D_h} \right] = \frac{152 \times 10^{-9} \text{ m}}{D_h} \quad (6)$$

$$\Gamma_p = \frac{2 - \alpha_p}{\alpha_p} \left[ \frac{\lambda_{\text{mfp}}}{D_h} \right] = \frac{2 - 0.87}{0.87} \cdot \left[ \frac{77.6 \times 10^{-9} \text{ m}}{D_h} \right] = \frac{101 \times 10^{-9} \text{ m}}{D_h} \quad (7)$$

$$\zeta = \frac{6\Gamma_p}{(1 + 6\Gamma_p)} \quad (8)$$

Equations 5 through 8 may be solved by trial-and-error to yield  $D_h = 3.97 \times 10^{-6} \text{ m} = 3.97 \text{ }\mu\text{m}$ . The plate spacing  $a = D_h/2 = 3.97 \text{ }\mu\text{m}/2 = 1.99 \text{ }\mu\text{m}$ . <

**COMMENTS:** The tube diameter and plate spacing required to reduce the Nusselt number by 10 percent are quite small. In situations involving characteristic dimensions that are not extremely small, the effect of the molecule-wall interaction can typically be neglected.

## PROBLEM 8.117

**KNOWN:** Diameters and length of three microchannels machined in a copper block. Inlet temperature of water flowing through the channels, copper block temperature, pressure difference from inlet to outlet of the channels.

**FIND:** (a) Mass flow rate and outlet temperature in each channel, (b) Average flow rate through each channel and average, mixed temperature of water collected from all three channels, (c) Comparison between average flow rates and average heat transfer rates based upon experiment to that calculated based upon a single microchannel diameter of 50  $\mu\text{m}$ .

**SCHEMATIC:**

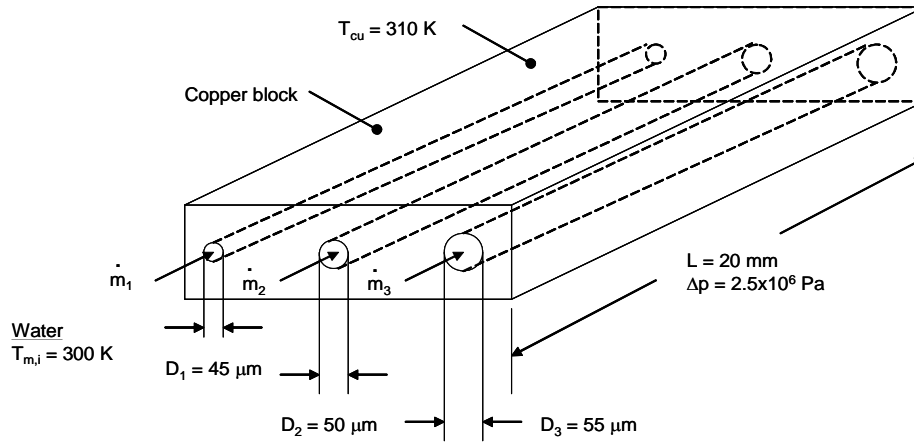

**ASSUMPTIONS:** (1) Constant properties and steady-state conditions, (2) Incompressible liquid and negligible viscous dissipation, (3) Negligible microscale or nanoscale effects, (4) Negligible entrance or exit losses in the microchannels, (5) Fully developed flow for purposes of calculating the mass flow rate in each channel, (6) Isothermal copper block.

**PROPERTIES:** Table A.6, water: ( $\bar{T}_m = 305 \text{ K}$ ):  $k = 0.620 \text{ W/m}\cdot\text{K}$ ,  $c_p = 4178 \text{ J/kg}\cdot\text{K}$ ,  $\mu = 769 \times 10^{-6} \text{ N}\cdot\text{s/m}^2$ ,  $\nu = 7.728 \times 10^{-7} \text{ m}^2/\text{s}$ ,  $\text{Pr} = 5.2$ ,  $\rho = 995 \text{ kg/m}^3$ .

**ANALYSIS:** (a) For the  $D = 50 \mu\text{m}$  channel, from Equation 8.22a,

$$\Delta p = f \rho u_m^2 L / 2D = f \times 995 \text{ kg/m}^3 \times u_m^2 \times 20 \times 10^{-3} \text{ m} / (2 \times 50 \times 10^{-6} \text{ m}) \quad (1)$$

where the friction factor may be evaluated using the Petukhov expression,

$$f = (0.790 \ln \text{Re}_D - 1.64)^{-2} \quad (2)$$

The Reynolds number may be expressed as

$$\text{Re}_D = \frac{u_m D}{\nu} = \frac{u_m \times 50 \times 10^{-6} \text{ m}}{7.728 \times 10^{-7} \text{ m}^2/\text{s}} \quad (3)$$

Continued...

### PROBLEM 8.117 (Cont.)

Simultaneous solution of Equations (1) through (3) yields, for the  $D = 50 \mu\text{m}$  channel,  $\text{Re}_D = 845$ ,  $u_m = 13.06 \text{ m/s}$ . The mass flow rate is

$$\dot{m} = \rho u_m \pi D^2 / 4 = 995 \text{ kg/m}^3 \times 13.06 \text{ m/s} \times \pi \times (50 \times 10^{-6} \text{ m})^2 / 4 = 2.55 \times 10^{-5} \text{ kg/s} \quad <$$

The thermal entrance length is  $x_{fd,t} = 0.05 \text{Re}_D \text{Pr}D = 0.05 \times 845 \times 5.2 \times 50 \times 10^{-6} \text{ m} = 11.0 \times 10^{-3} \text{ m} = 11.0 \text{ mm}$ . From the Hausen correlation,

$$\overline{\text{Nu}}_D = 3.66 + \frac{0.0668 \times (50 \times 10^{-6} \text{ m} / 20 \times 10^{-3} \text{ m}) \times 845 \times 5.2}{1 + 0.04 \times \left[ (50 \times 10^{-6} \text{ m} / 20 \times 10^{-3} \text{ m}) \times 845 \times 5.2 \right]^{2/3}} = 4.27$$

Hence,

$$\bar{h} = \frac{\overline{\text{Nu}}_D k}{D} = \frac{4.27 \times 0.62 \text{ W/m} \cdot \text{K}}{50 \times 10^{-6} \text{ m}} = 5.29 \times 10^4 \text{ W/m}^2 \cdot \text{K}$$

From Equation 8.42,

$$\begin{aligned} T_m(x=L) &= T_s - [T_s - T_{m,i}] \exp\left(-\frac{PL}{\dot{m}c_p} \bar{h}\right) \\ &= 310\text{K} - [310\text{K} - 300\text{K}] \exp\left(-\frac{\pi \times 50 \times 10^{-6} \text{ m}}{2.55 \times 10^{-5} \text{ kg/s} \times 4178 \text{ J/kg} \cdot \text{K}} \times 5.29 \times 10^4 \text{ W/m}^2 \cdot \text{K}\right) \\ &= 307.9\text{K} = 34.9^\circ\text{C} = T_{m,o} \end{aligned} \quad <$$

Results for the three different channels are shown in the table below. <

	<u><math>D = 45 \mu\text{m}</math> (case 1)</u>	<u><math>D = 50 \mu\text{m}</math> (case 2)</u>	<u><math>D = 55 \mu\text{m}</math> (case 3)</u>
$\text{Re}_D$	690	845	1012
$u_m$ (m/s)	11.85	13.06	14.23
$\dot{m}$ (kg/s)	$1.88 \times 10^{-5}$	$2.55 \times 10^{-5}$	$3.36 \times 10^{-5}$
$x_{fd,t}$ (mm)	8.1	11.0	14.5
$\overline{\text{Nu}}_D$	4.12	4.27	4.44
$\bar{h}$ ( $\text{W/m}^2 \cdot \text{K}$ )	$5.68 \times 10^4$	$5.29 \times 10^4$	$5.01 \times 10^4$
$T_{m,o}$ (K)	308.7	307.9	307.1

Continued...

### PROBLEM 8.117 (Cont.)

(b) The average mass flow rate is

$$\bar{m} = (\dot{m}_1 + \dot{m}_2 + \dot{m}_3)/3 = \left[ (1.88 \times 10^{-5} + 2.55 \times 10^{-5} + 3.36 \times 10^{-5}) \text{kg/s} \right] / 3 = 2.60 \times 10^{-5} \text{kg/s} \quad <$$

(c) The average, mixed outlet temperature is

$$\begin{aligned} T_{m,o} &= (\dot{m}_1 T_{m,o,1} + \dot{m}_2 T_{m,o,2} + \dot{m}_3 T_{m,o,3}) / (\dot{m}_1 + \dot{m}_2 + \dot{m}_3) \\ &= \frac{(1.88 \times 10^{-5} \text{kg/s} \times 308.7 \text{K} + 2.55 \times 10^{-5} \text{kg/s} \times 307.9 \text{K} + 3.36 \times 10^{-5} \text{kg/s} \times 307.1 \text{K})}{(1.88 \times 10^{-5} + 2.55 \times 10^{-5} + 3.36 \times 10^{-5}) \text{kg/s}} = 307.7 \text{K} \end{aligned}$$

(d) Equation 8.42 may be re-arranged to

$$\bar{h} = -\frac{\dot{m} c_p}{PL} \ln \left( \frac{T_s - T_{m,o}}{T_s - T_{m,L}} \right) = -\frac{2.60 \times 10^{-5} \text{kg/s} \times 4178 \text{J/kg} \cdot \text{K}}{\pi \times 50 \times 10^{-6} \text{m} \times 20 \times 10^{-3} \text{m}} \ln \left( \frac{310 - 307.7}{310 - 300} \right) = 50,800 \text{W/m}^2 \cdot \text{K}$$

Thus, the inferred value of the mass flow rate is 2% greater than the predicted value for a 50  $\mu\text{m}$  diameter channel. The inferred value of the convection coefficient (50,800 W/m<sup>2</sup>·K) is 4% less than the predicted value for a 50  $\mu\text{m}$  diameter channel. The experimenter must carefully assess his or her claims since the differences are small and might be attributed to variations in the channel dimensions that occur during their manufacture.

**COMMENTS:** (1) Experimentation at the microscale is challenging. Misinterpretation of the experimental results might occur unless the experimental system is designed very carefully. For example, the diameters of the channels might need to be measured after their manufacture. (2) When boring holes, the hole diameter is always greater than the diameter of the tool. If the experimentalist assumes that the actual hole size is the same as the tool size, what (inappropriate) conclusions might he or she make regarding possible microscale fluid flow and heat transfer effects when analyzing the measured results?

### PROBLEM 8.118

**KNOWN:** Air flow through a plastic tube in which evaporation occurs.

**FIND:** Convection mass transfer coefficient,  $h_m$ .

**SCHEMATIC:**

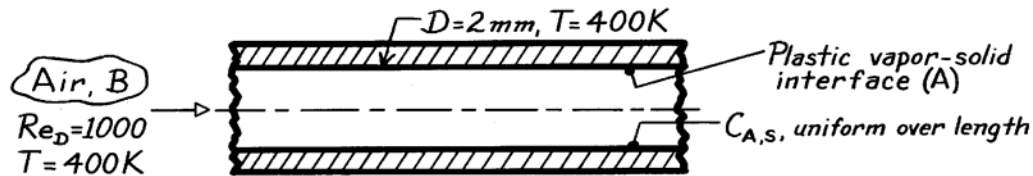

**ASSUMPTIONS:** (1) Steady-state conditions, (2) Constant properties, (3) Heat-mass transfer analogy applicable, (4) Fully-developed flow and mass transfer conditions.

**PROPERTIES:** Plastic-air (given, 400K):  $Sc = \nu/D_{AB} = 2.0$ ; Table A-4, Air (400K, 1 atm):  $\nu = 26.41 \times 10^{-6} \text{ m}^2/\text{s}$ .

**ANALYSIS:** For fully-developed flow and thermal conditions with laminar flow and a uniform surface temperature,

$$Nu_D = \frac{h D}{k} = 3.66$$

This situation is analogous to the evaporation of plastic vapor into the air stream with the inner surface remaining at a constant concentration of plastic vapor,  $C_{A,s}$ , along the length of the tube. Invoking the heat-mass transfer analogy,

$$Sh_D = \frac{h_m D}{D_{AB}} = 3.66.$$

Recognizing that  $Sc = \nu/D_{AB}$ ,

$$h_m = 3.66 \left( \frac{\nu}{Sc} \right) \frac{1}{D} = 3.66 \times \frac{26.4 \times 10^{-6} \text{ m}^2/\text{s}}{2.0} \times \frac{1}{2 \times 10^{-3} \text{ m}} = 2.42 \times 10^{-2} \text{ m/s.} \quad <$$

**COMMENTS:** (1) The heat-mass transfer analogy requires that the vapor (A) have a negligible effect on the flow. Hence, the flow is that of air (B) and  $\nu = \nu_B$ .

(2) Only the mixture property  $D_{AB}$  is required to characterize the plastic vapor for this evaporation process.

### PROBLEM 8.119

**KNOWN:** Air passing upward through a tube having a thin water film on its inside surface.

**FIND:** Convection mass transfer coefficient.

**SCHEMATIC:**

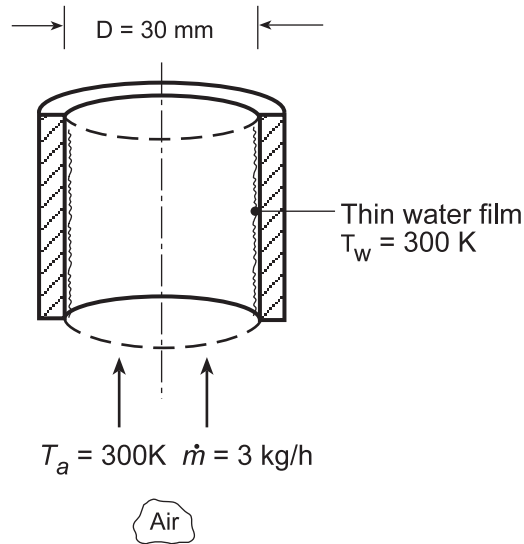

**ASSUMPTIONS:** (1) Steady-state conditions, (2) Constant properties, (3) Heat-mass analogy applicable, and (4) Fully developed flow and thermal conditions.

**PROPERTIES:** Table A.4, Air (300 K, 1 atm):  $\mu = 184.6 \times 10^{-7}\text{ N}\cdot\text{s}/\text{m}^2$ ,  $k = 0.0263\text{ W}/\text{m}\cdot\text{K}$ ; Table A.8, Water vapor-air (300 K, 1 atm):  $D_{AB} = 0.26 \times 10^{-4}\text{ m}^2/\text{s}$ .

**ANALYSIS:** Begin by characterizing the air flow with the Reynolds number,

$$\text{Re}_D = \frac{4\dot{m}}{\pi D \mu} = \frac{4 \times (3/3600)\text{ kg/s}}{\pi \times 0.030\text{ m} \times 184.6 \times 10^{-7}\text{ N/s}\cdot\text{m}^2} = 1916$$

Since the flow is laminar, and assuming fully developed flow and thermal conditions, Eq. 8.55 is appropriate for the uniform  $T_s$  wall condition,

$$\text{Nu}_D = \frac{hD}{k} = 3.66 \quad h = \frac{0.0263\text{ W}/\text{m}\cdot\text{K}}{0.030\text{ m}} \times 3.66 = 3.21\text{ W}/\text{m}^2\cdot\text{K}$$

Invoking the heat-mass analogy, for laminar flow conditions,

$$\text{Sh}_D = \frac{h_m D}{D_{AB}} = \text{Nu}_D$$

$$h_m = \frac{D_{AB}}{D} \text{Nu}_D = \frac{0.26 \times 10^{-4}\text{ m}^2/\text{s}}{0.030\text{ m}} \times 3.66 = 0.0032\text{ m/s} \quad \leftarrow$$

**COMMENTS:** (1) The heat-mass analogy requires that the water vapor (A) have negligible effect on the velocity boundary layer. It is important to recognize that the vapor is species (A) and the air species (B). Hence the flow is that of air (B) and hence  $\mu = \mu_B$ .

(2) Note only the mixture property  $D_{AB}$  is required to characterize the water vapor for this evaporation process.

### PROBLEM 8.120

**KNOWN:** Temperature and flow rate of air in a tube with a naphthalene coated inner surface.

**FIND:** Convection mass transfer coefficient under fully developed conditions and velocity and concentration entry lengths.

**SCHEMATIC:**

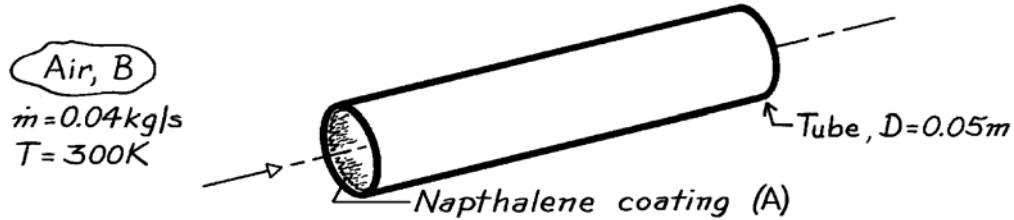

**ASSUMPTIONS:** (1) Heat and mass transfer analogy is applicable, (2) Uniform vapor concentration along inner surface.

**PROPERTIES:** Table A-4, Air (300 K, 1 atm):  $\mu = 184.6 \times 10^{-7} \text{ N}\cdot\text{s/m}^2$ ,  $\nu = 15.89 \times 10^{-6} \text{ m}^2/\text{s}$ ; Table A-8, Naphthalene-air (300K, 1 atm):  $D_{AB} = 6.2 \times 10^{-6} \text{ m}^2/\text{s}$ ,  $Sc = \mu/D_{AB} = 2.56$ .

**ANALYSIS:** For air flow through the tube,

$$Re_D = \frac{4 \dot{m}}{\pi D \mu} = \frac{4 \times 0.04 \text{ kg/s}}{\pi (0.05 \text{ m}) 184.6 \times 10^{-7} \text{ N}\cdot\text{s/m}^2} = 55,178.$$

Hence the flow is turbulent and from Eq. 8.88,

$$Sh_D = 0.023 Re_D^{4/5} Sc^{0.4} = 0.023 (55,178)^{4/5} (2.56)^{0.4} = 208$$

$$h_m = \frac{D_{AB}}{D} Sh_D = \frac{6.2 \times 10^{-6} \text{ m}^2/\text{s}}{0.05 \text{ m}} 208 = 0.026 \text{ m/s.} \quad <$$

From Eq. 8.4, it follows that

$$10D \leq x_{fd,h} \approx x_{fd,c} \leq 60D$$

or

$$0.5 \text{ m} \leq x_{fd,h} \approx x_{fd,c} \leq 3 \text{ m.} \quad <$$

An entry length of 0.5 m is assumed.

**COMMENTS:** Note that the flow properties are taken to be those of the air, with the contribution of the naphthalene vapor assumed to be negligible.

## PROBLEM 8.121

**KNOWN:** Air flow over roughened section of tube constructed from naphthalene.

**FIND:** Mass and heat transfer convection coefficients associated with the roughened section; contrast these results with those for a smooth section.

**SCHEMATIC:**

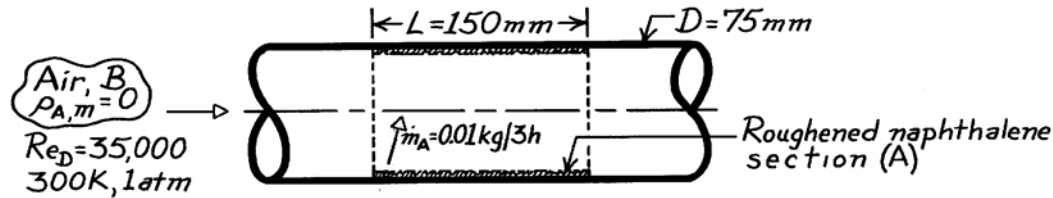

**ASSUMPTIONS:** (1) Steady-state conditions, (2) Heat-mass transfer analogy applicable, (3) Negligible naphthalene vapor in airstream,  $\rho_{A,m} = 0$ , (4) Constant properties, (5) Naphthalene vapor behaves as perfect gas.

**PROPERTIES:** Table A-4, Air (300K, 1 atm):  $\nu = 15.89 \times 10^{-6} \text{ m}^2/\text{s}$ ,  $k = 0.0263 \text{ W/m}\cdot\text{K}$ ,  $Pr = 0.707$ ; Table A-8, Naphthalene-air mixture (300K, 1 atm):  $D_{AB} = 0.62 \times 10^{-5} \text{ m}^2/\text{s}$ ,  $Sc = \nu_B/D_{AB} = 2.563$ ; Naphthalene (given, 300K):  $p_{\text{sat},A} = 1.31 \times 10^{-4} \text{ bar}$ ,  $M_A = 128.16 \text{ kg/kmol}$ .

**ANALYSIS:** Using the rate equation with the experimentally observed sublimation rate of naphthalene vapor, the average mass transfer coefficient for the section is

$$h_m = \dot{m}_A / (\pi DL) (\rho_{A,s} - \rho_{A,m})$$

$$\rho_{A,m} = 0 \quad \rho_{A,s} = \rho_{A,\text{sat}}(300\text{K}) = M_A p_{\text{sat},A} / \mathcal{R}T$$

$$\rho_{A,s} = 128.16 \text{ kg/kmol} \times \frac{1.31 \times 10^{-4} \text{ bar}}{8.314 \times 10^{-2} \text{ m}^3 \cdot \text{bar/kmol} \cdot \text{K} \times 300 \text{ K}} = 6.731 \times 10^{-4} \text{ kg/m}^3$$

$$h_m = \frac{0.010 \text{ kg}}{3 \times 3600 \text{ s}} / (\pi \times 0.075 \text{ m} \times 0.150 \text{ m}) (6.731 \times 10^{-4} - 0) \text{ kg/m}^3 = 3.89 \times 10^{-2} \text{ m/s} \quad <$$

Invoking the heat-mass transfer analogy, the associated heat transfer coefficient is

$$h = h_m \frac{k}{D_{AB}} \left( \frac{Pr}{Sc} \right)^{1/3} = 3.89 \times 10^{-2} \text{ m/s} \frac{0.0263 \text{ W/m}\cdot\text{K}}{0.62 \times 10^{-5} \text{ m}^2/\text{s}} \left( \frac{0.707}{2.563} \right)^{1/3} = 107 \text{ W/m}^2 \cdot \text{K} \quad <$$

The corresponding convection coefficients for a *smooth* section can be estimated using the Dittus-Boelter relation (the heating condition,  $n = 0.4$ , has been selected),

$$h = \frac{k}{D} 0.023 Re_D^{4/5} Pr^{0.4} = (0.0263 \text{ W/m}\cdot\text{K} / 0.075 \text{ m}) \times 0.023 (35,000)^{4/5} (0.707)^{0.4} = 30 \text{ W/m}^2 \cdot \text{K} \quad <$$

Using the analogous mass transfer relation, Eq. 8.88,

$$h_m = (D_{AB} / D) 0.023 Re_D^{4/5} Sc^{0.4} = (0.62 \times 10^{-5} \text{ m}^2/\text{s} / 0.075 \text{ m}) \times 0.023 (35,000)^{4/5} (2.563)^{0.4}$$

$$h_m = 1.20 \times 10^{-2} \text{ m/s} \quad <$$

**COMMENTS:** The effect of roughening is to increase the convection coefficients over the corresponding value for the smooth condition; in this case, by a factor of approximately 3.5.



## PROBLEM 8.122

**KNOWN:** Dry air with prescribed velocity and temperature flowing over a thin-walled tube with a water-saturated fibrous coating. Water passes at a prescribed rate through the tube to maintain an approximately uniform surface temperature  $T_s = 27^\circ\text{C}$ .

**FIND:** (a) Heat rate from the external surface of the tube considering heat and mass transfer processes and (b) For a flow rate of  $\dot{m} = 0.025 \text{ kg/s}$ , the inlet temperature,  $T_{m,i}$ , of the water that must be supplied to the tube.

**SCHEMATIC:**

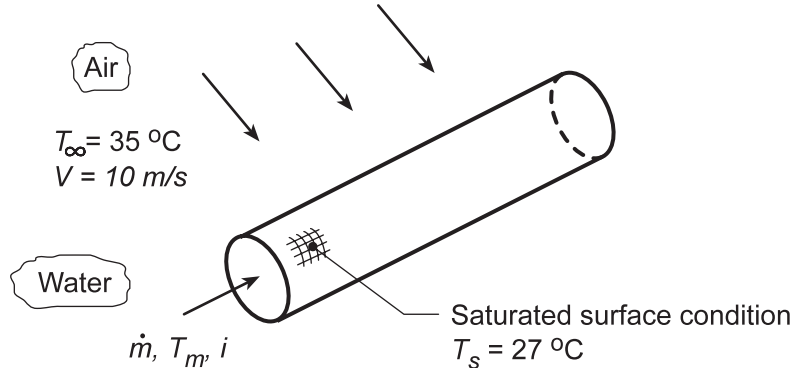

**ASSUMPTIONS:** (1) Steady-state conditions, (2) Constant properties, (3) Heat-mass analogy applicable, and (4) Water in tube flow is incompressible with negligible viscous dissipation.

**PROPERTIES:** Table A.4, Air ( $\bar{T}_f = (T_s + T_\infty)/2 = 304 \text{ K}$ ):  $\rho = 1.148 \text{ kg/m}^3$ ,  $c_p = 1007 \text{ J/kg}\cdot\text{K}$ ,  $\nu = 16.29 \times 10^{-6} \text{ m}^2/\text{s}$ ,  $k = 0.0266 \text{ W/m}\cdot\text{K}$ ,  $\alpha = 23.09 \times 10^{-6} \text{ m}^2/\text{s}$ ,  $\text{Pr} = 0.706$ ; Table A.6, Water ( $T_s = 300 \text{ K}$ ):  $\rho_{A,s} = 1/\nu_g = 0.02556 \text{ kg/m}^3$ ,  $h_{fg} = 2438 \text{ kJ/kg}$ ,  $\mu = 855 \times 10^{-6} \text{ N}\cdot\text{s/m}^2$ ; Table A.6, Water ( $\bar{T}_m = 305 \text{ K}$ ):  $\rho = 995 \text{ kg/m}^3$ ,  $c_p = 4178 \text{ J/kg}\cdot\text{K}$ ,  $\mu = 769 \times 10^{-6} \text{ N}\cdot\text{s/m}^2$ ,  $k = 0.620 \text{ W/m}\cdot\text{K}$ ,  $\text{Pr} = 5.20$ ; Table A.8, Water vapor-air ( $T_s = 300 \text{ K}$ ):  $D_{AB} = 0.26 \times 10^{-4} \text{ m}^2/\text{s}$ .

**ANALYSIS:** (a) On the Schematic above, the surface energy balance yields

$$q_{\text{out}} = q_{\text{conv}} + q_{\text{evap}} \quad (1)$$

and substituting the rate equations,

$$q_{\text{conv}} = \bar{h}_o A_s (T_s - T_\infty) \quad q_{\text{evap}} = n_A h_{fg} = \bar{h}_m A_s (\rho_{A,s} - \rho_{A,\infty}) h_{fg} \quad (2,3)$$

where  $\bar{h}_o$  can be estimated from an appropriate correlation and  $\bar{h}_m$  from the heat-mass analogy using  $\bar{h}_o$ .

*Estimation of the heat transfer coefficient,  $\bar{h}_o$ :* The Reynolds number, evaluated with properties at  $\bar{T}_f = (T_s + T_\infty)/2 = 304 \text{ K}$ , is

$$\text{Re}_{D,o} = \frac{VD}{\nu} = \frac{10 \text{ m/s} \times 0.020 \text{ m}}{1.629 \times 10^{-5} \text{ m}^2/\text{s}} = 12,277 \quad (4)$$

Using the Churchill-Bernstein correlation, Eq. 7.54, for cross flow over a cylinder, find  $\bar{h}_o$

$$\text{Nu}_{D,o} = 0.3 + \frac{0.62 \text{Re}_{D,o}^{1/2} \text{Pr}_o^{1/3}}{\left[1 + (0.4/\text{Pr}_o)^{2/3}\right]^{1/4}} \left[1 + \left(\frac{\text{Re}_{D,o}}{282,000}\right)^{5/8}\right]^{4/5} \quad (5)$$

Continued...

**PROBLEM 8.122 (Cont.)**

$$\text{Nu}_{D,o} = 0.3 + \frac{0.62(12,277)^{1/2} (0.706)^{1/3} \left[ 1 + \left( \frac{12,277}{282,000} \right)^{5/8} \right]^{4/5}}{\left[ 1 + (0.4/0.706)^{2/3} \right]^{1/4}}$$

$$\bar{h}_o = \frac{k}{D} \text{Nu}_{D,o} = \frac{0.0266 \text{ W/m} \cdot \text{K}}{0.020 \text{ m}} \times 60.1 = 80.0 \text{ W/m}^2 \cdot \text{K}$$

*The Heat-Mass Analogy:* From Eq. 6.60, with  $n = 1/3$ ,

$$\frac{\bar{h}_o}{\bar{h}_m} = \rho c_p \text{Le}^{2/3} = \rho c_p \left( \frac{\alpha}{D_{AB}} \right)^{2/3} \quad (6)$$

$$\bar{h}_m = 80.0 \text{ W/m}^2 \cdot \text{K} \left/ \left[ 1.148 \text{ kg/m}^3 \times 1007 \text{ J/kg} \cdot \text{K} \left( 23.09 \times 10^{-6} \text{ m}^2/\text{s} / 0.26 \times 10^{-4} \text{ m}^2/\text{s} \right)^{2/3} \right] \right. = 0.0749 \text{ m/s}$$

Hence, the heat rate leaving the tube surface from Eq. (1) is,

$$q_{\text{out}} = \left[ 80 \text{ W/m}^2 \cdot \text{K} (27 - 35)^\circ \text{C} + 0.0749 \text{ m/s} (0.02556 - 0) \text{ kg/m}^3 \times 2438 \times 10^3 \text{ J/kg} \right] (\pi \times 0.020 \text{ m} \times 0.200 \text{ m})$$

$$q_{\text{out}} = -8.04 \text{ W} + 58.65 = 50.6 \text{ W} \quad <$$

(b) For tube flow analysis, the heat rate and rate equations are

$$q = \dot{m} c_p (T_{m,o} - T_{m,i}) \quad \frac{T_s - T_{m,o}}{T_s - T_{m,i}} = \exp \left( - \frac{\pi D L}{\dot{m} c_p} \right) \bar{h}_i \quad (7,8)$$

where  $T_s = 27^\circ\text{C}$ , the uniform temperature of the tube surface, and  $q = -50.6 \text{ W}$  according to the analysis of part (a). To estimate  $\bar{h}_i$ , first characterize the flow,

$$\text{Re}_{D,i} = \frac{4\dot{m}}{\pi D \mu_i} = \frac{4 \times 0.025 \text{ kg/s}}{\pi \times 0.020 \text{ m} \times 769 \times 10^{-6} \text{ N} \cdot \text{s/m}^2} = 2070 \quad (9)$$

using properties evaluated at an assumed mean temperature,  $\bar{T}_m = 305 \text{ K}$  (slightly above  $T_s$ ). The flow is laminar, and with  $\text{Pr} > 5$ , the Hausen correlation, Eq. 8.57 applies, with  $\text{Gz}_D = (D/L)\text{Re}_D\text{Pr} = (0.02 \text{ m}/0.2 \text{ m}) \times 2070 \times 5.2 = 1076$ . Thus,

$$\overline{\text{Nu}}_{D,i} = \frac{\bar{h}_i D}{k} = 3.66 + \frac{0.0668 \text{ Gz}_D}{1 + 0.04 \text{ Gz}_D^{2/3}} = 3.66 + \frac{0.0668 \times 1076}{1 + 0.04(1076)^{2/3}} = 17.5$$

$$\bar{h}_i = \frac{k_i}{D} \overline{\text{Nu}}_{D,i} = \frac{0.620 \text{ W/m} \cdot \text{K}}{0.020 \text{ m}} \times 17.5 = 542 \text{ W/m}^2 \cdot \text{K}$$

Referring to Eqs. (7) and (8), recognize that there are two unknowns,  $T_{m,i}$  and  $T_{m,o}$ , as we have evaluated both  $q$  and  $\bar{h}_i$ . Using the IHT solver,

$$T_{m,i} = 307.7 \text{ K}, \quad T_{m,o} = 307.2 \text{ K} \quad <$$

Continued...

## PROBLEM 8.122 (Cont.)

**COMMENTS:** Using the *IHT Rate Equation Tool, Rate Equation for a Tube, Constant Surface Temperature*, and the *Correlation, Internal Flow, Laminar, Thermal Entry Length*, a model to perform the analysis for part (b) was developed and is copied below.

**// Rate Equation Tool - Tube, Constant Surface Temperature:**

```

/* For flow through a tube with a uniform wall temperature, Fig 8.7b, the
overall energy balance and heat rate equations are */
q = mdot*cp*(Tmo - Tmi)           // Heat rate, W; Eq 8.34
q = -50.64                        // Heat rate, W; required to sustain heat loss on outer surface
(Ts - Tmo) / (Ts - Tmi) = exp ( - P * L * h / (mdot * cp)) // Eq 8.41b
// where the fluid and constant tube wall temperatures are
Ts = 27 + 273                     // Tube wall temperature, K
// The tube parameters are
P = pi * D                       // Perimeter, m
D = 0.020                        // Tube diameter, m
L = 0.20                         // Tube length, m
// The tube mass flow rate and fluid thermophysical properties are
mdot = 0.025

```

**// Properties Tool - Water**

```

// Water property functions :T dependence, From Table A.6
// Units: T(K), p(bars);
x = 0                             // Quality (0=sat liquid or 1=sat vapor)
cp = cp_Tx("Water",Tm,x)         // Specific heat, J/kg-K
mu = mu_Tx("Water",Tm,x)         // Viscosity, N-s/m^2
k = k_Tx("Water",Tm,x)           // Thermal conductivity, W/m-K
Pr = Pr_Tx("Water",Tm,x)         // Prandtl number
Tm = Tfluid_avg(Tmo, Tmi)        // Average mean temperature, K

```

**// Correlations Tool - Internal Flow, Laminar, combined entry length**

```

NuDbar = NuD_bar_IF_L_TEL_CWT(ReD,Pr,D,L) // Eq 8.57
NuDbar = h * D / k
ReD = 4*mdot/(P*mu)

```

**/\* Data Browser results:**

cp	h	k	mu	NuDbar	P	Pr	ReD	Tm	Tmi
Tmo	D	L	mdot	q	Ts	x			
4178	543.8	0.6239	0.000733	17.43	0.06283	4.918	2171	307.4	307.7
307.2	0.02	0.2	0.025	-50.64	300	0			

\*/

### PROBLEM 8.123

**KNOWN:** Density and flow rate of gas through a tube with evaporation or sublimation at the tube surface.

**FIND:** (a) Longitudinal distribution of mean vapor density, (b) Total rate of vapor transfer.

**SCHEMATIC:**

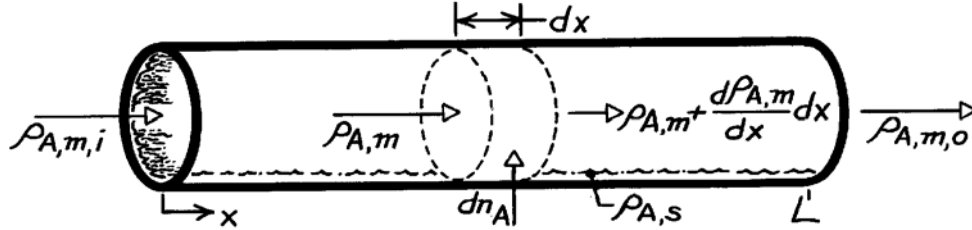

**ASSUMPTIONS:** (1) Steady, incompressible flow, (2) Flow rate is independent of \$x\$, (3) Negligible chemical reactions, (4) Uniform perimeter \$P\$.

**ANALYSIS:** (a) Applying conservation of species to a differential control volume

$$\rho_{A,m} u_m A_c + dn_A = \left( \rho_{A,m} + \frac{d\rho_{A,m}}{dx} dx \right) u_m A_c$$

or, with  $u_m A_c = \dot{m}/\rho$  and  $dn_A = h_m P dx (\rho_{A,s} - \rho_{A,m})$ ,

$$\frac{\dot{m}}{\rho} \frac{d\rho_{A,m}}{dx} dx = h_m P dx (\rho_{A,s} - \rho_{A,m}).$$

Separating variables and integrating,

$$\int_{\rho_{A,m,i}}^{\rho_{A,m}} \frac{d\rho_{A,m}}{\rho_{A,s} - \rho_{A,m}} = \int_0^x \frac{\rho h_m P}{\dot{m}} dx = \frac{\rho P}{\dot{m}} \int_0^x h_m dx$$

$$\ell_n \frac{\rho_{A,s} - \rho_{A,m}}{\rho_{A,s} - \rho_{A,m,i}} = -\frac{\rho P x \bar{h}_m}{\dot{m}} \quad \text{or} \quad \frac{\rho_{A,s} - \rho_{A,m}(x)}{\rho_{A,s} - \rho_{A,m,i}} = \exp\left(-\frac{\rho P x \bar{h}_m}{\dot{m}}\right). \quad (1) <$$

(b) With  $\Delta\rho_A \equiv \rho_{A,s} - \rho_{A,m}$ ,

$$n_A = (\dot{m}/\rho) (\rho_{A,m,o} - \rho_{A,m,i}) = -(\dot{m}/\rho) (\Delta\rho_{A,o} - \Delta\rho_{A,i})$$

and from Eq. (1) with

$$-\frac{\dot{m}}{\rho} = P L \bar{h}_m / \ell_n \frac{\Delta\rho_{A,o}}{\Delta\rho_{A,i}}$$

it follows that

$$n_A = \bar{h}_m P L \frac{\Delta\rho_{A,o} - \Delta\rho_{A,i}}{\ell_n (\Delta\rho_{A,o} / \Delta\rho_{A,i})}. <$$

**COMMENTS:** Due to the addition of vapor,  $\dot{m}$  will actually increase with \$x\$. However, if the specific humidity of the saturated gas-vapor mixture is small (as is usually the case), the change in  $\dot{m}$  will be small.

### PROBLEM 8.124

**KNOWN:** Flow rate and temperature of air. Tube diameter and length. Presence of water film on tube inner surface.

**FIND:** (a) Vapor density at tube outlet, (b) Evaporation rate.

**SCHEMATIC:**

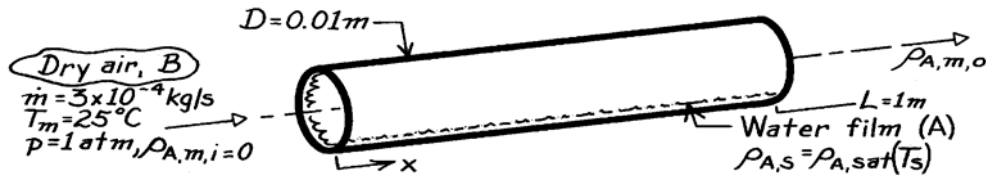

**ASSUMPTIONS:** (1) Steady, incompressible flow, (2) Constant flow rate, (3) Isothermal system (water film maintained at 25°C).

**PROPERTIES:** Table A-4, Air (1 atm, 298 K):  $\rho = 1.1707 \text{ kg/m}^3$ ,  $\mu = 183.6 \times 10^{-7} \text{ N}\cdot\text{s/m}^2$ ,  $\nu = 15.71 \times 10^{-6} \text{ m}^2/\text{s}$ ; Table A-6, Water vapor (298 K):  $\rho_{A,\text{sat}} = 1/v_g = (1/44.25 \text{ m}^3/\text{kg}) = 0.0226 \text{ kg/m}^3$ ; Table A-8, Air-vapor (298 K):  $D_{AB} = 26 \times 10^{-6} \text{ m}^2/\text{s}$ ;  $Sc = \nu/D_{AB} = 0.60$ .

**ANALYSIS:** (a) We begin by determining the whether the flow is laminar or turbulent.

$$Re_D = \frac{4 \dot{m}}{\pi D \mu} = \frac{4 \times 3 \times 10^{-4} \text{ kg/s}}{\pi (0.01 \text{ m}) 183.6 \times 10^{-7} \text{ N}\cdot\text{s/m}^2} = 2080.$$

Flow is laminar and from Eq. 8.3 and the mass transfer analogy to Eq. 8.23,

$$x_{fd,h} = 0.05 Re_D D = 0.05 \times 2080 \times 0.01 \text{ m} = 1.04 \text{ m}, \quad x_{fd,c} = x_{fd,h} Sc = 1.04 \text{ m} \times 0.60 = 0.62 \text{ m}$$

Thus this is a combined entry length situation and the mass transfer analogy to the Baehr and Stephan correlation, Eq. 8.58, is appropriate. By analogy to Eq. 8.57,  $Gz_{m,D} = (D/L) Re_D Sc = (0.01 \text{ m}/1 \text{ m}) \times 2080 \times 0.60 = 12.5$ , and

$$\begin{aligned} \overline{Sh}_D &= \frac{\overline{h}_m D}{D_{AB}} = \frac{3.66}{\tanh[2.264 Gz_{m,D}^{-1/3} + 1.7 Gz_{m,D}^{-2/3}]} + \frac{0.0499 Gz_{m,D} \tanh(Gz_{m,D}^{-1})}{\tanh(2.432 Sc^{1/6} Gz_{m,D}^{-1/6})} \\ &= \frac{3.66}{\tanh[2.264 \times 12.5^{-1/3} + 1.7 \times 12.5^{-2/3}]} + \frac{0.0499 \times 12.5 \tanh(12.5^{-1})}{\tanh(2.432 \times 0.60^{1/6} \times 12.5^{-1/6})} = 4.79 \end{aligned}$$

$$\overline{h}_m = \frac{\overline{Sh}_D D_{AB}}{D} = \frac{4.79 \times 26 \times 10^{-6} \text{ m}^2/\text{s}}{0.01 \text{ m}} = 0.0125 \text{ m/s}$$

From Equation 8.86,

$$\rho_{A,m,o} = \rho_{A,s} - (\rho_{A,s} - \rho_{A,m,i}) \exp\left(-\frac{\pi DL}{\dot{m}} \rho \overline{h}_m\right)$$

where  $\rho_{A,s} = \rho_{A,\text{sat}} = 0.0226 \text{ kg/m}^3$ . Thus,

Continued ...

**PROBLEM 8.124 (Cont.)**

$$\begin{aligned}\rho_{A,m,o} &= 0.0226 \text{ kg/m}^3 \\ &- \left(0.0226 \text{ kg/m}^3 - 0\right) \exp\left(-\frac{\pi \cdot 0.01 \text{ m} \times 1 \text{ m}}{3 \times 10^{-4} \text{ kg/s}} \times 1.1707 \text{ kg/m}^3 \times 0.0125 \text{ m/s}\right) < \\ &= 0.0177 \text{ kg/m}^3\end{aligned}$$

(b) The evaporation rate is

$$n_A = u_m A_c (\rho_{A,m,o} - \rho_{A,m,i}) = \frac{\dot{m}}{\rho} (\rho_{A,m,o}) = \frac{3 \times 10^{-4} \text{ kg/s}}{1.1707 \text{ kg/m}^3} \cdot 0.0177 \frac{\text{kg}}{\text{m}^3} = 4.54 \times 10^{-6} \text{ kg/s.} <$$

### PROBLEM 8.125

**KNOWN:** Flow rate and temperature of air in circular tube of prescribed diameter. Inner tube surface is wetted. Flow is fully developed and inlet air is dry.

**FIND:** Tube length required to reach 99% of saturation.

**SCHEMATIC:**

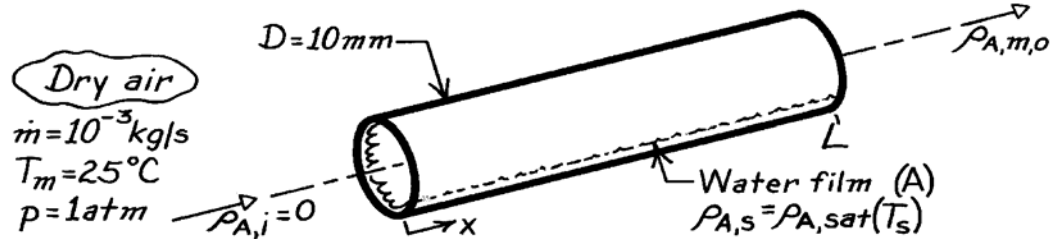

**ASSUMPTIONS:** (1) Steady, incompressible flow, (2) Constant flow rate, (3) Water film is also at 25°C.

**PROPERTIES:** Table A-4, Air (298 K, 1 atm):  $\rho = 1.17 \text{ kg/m}^3$ ,  $\mu = 183.6 \times 10^{-7} \text{ N}\cdot\text{s/m}^2$ ,  $\nu = 15.71 \times 10^{-6} \text{ m}^2/\text{s}$ ; Table A-6, Water vapor (298 K):  $\rho_{A,\text{sat}} = 1/v_g = (1/44.25 \text{ m}^3/\text{kg}) = 0.0226 \text{ kg/m}^3$ ; Table A-8, Air-vapor (298 K):  $D_{AB} = 26 \times 10^{-6} \text{ m}^2/\text{s}$ ,  $Sc = \nu/D_{AB} = 0.60$ .

**ANALYSIS:** If  $\rho_{A,m,o} = 0.99 \rho_{A,s}$ , it follows from Equation 8.86 that

$$\frac{\rho_{A,s} - 0.99 \rho_{A,s}}{\rho_{A,s}} = 0.01 = \exp\left(-\frac{\pi DL \rho \bar{h}_m}{\dot{m}}\right).$$

With

$$Re_D = \frac{4 \dot{m}}{\pi D \mu} = \frac{4 \times 10^{-3} \text{ kg/s}}{\pi (0.01 \text{ m}) 183.6 \times 10^{-7} \text{ N}\cdot\text{s/m}^2} = 6935$$

the flow is turbulent and from Eq. 8.88

$$Sh_D = 0.023 Re_D^{4/5} Sc^{0.4} = 0.023 (6935)^{4/5} (0.60)^{0.4} = 22.2$$

$$\bar{h}_m = \frac{Sh_D D_{AB}}{D} = \frac{22.2 \times 26 \times 10^{-6} \text{ m}^2/\text{s}}{0.01 \text{ m}} = 0.0576 \text{ m/s}.$$

Hence

$$0.01 = \exp\left(-\frac{\pi \times 0.01 \text{ m} \times L \times 1.17 \text{ kg/m}^3}{10^{-3} \text{ kg/s}} 0.0576 \text{ m/s}\right)$$

$$0.01 = \exp(-2.12 L)$$

$$L = 2.2 \text{ m}.$$

<

**COMMENT:** With  $Re_D < 10,000$ , the mass transfer analog of the Gnielinski correlation would be preferable.

### PROBLEM 8.126

**KNOWN:** Flow rate and temperature of atmospheric air in circular tube of prescribed diameter. Flow is fully developed, and air is dry. Inner tube surface is wetted.

**FIND:** (a) Tube length required to reach 99% saturation, (b) Heat rate needed to maintain tube surface at air temperature.

**SCHEMATIC:**

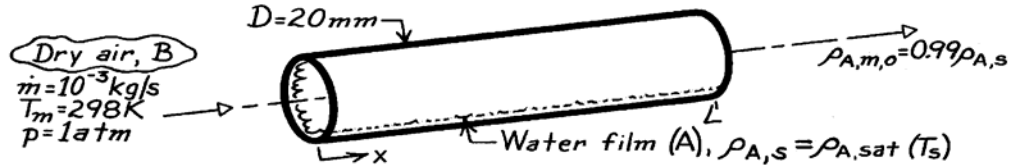

**ASSUMPTIONS:** (1) Steady, incompressible flow, (2) Constant flow rate.

**PROPERTIES:** Table A-4, Air (298 K, 1 atm):  $\rho = 1.17 \text{ kg/m}^3$ ,  $\mu = 183.6 \times 10^{-7} \text{ N}\cdot\text{s/m}^2$ ,  $\nu = 15.71 \times 10^{-6} \text{ m}^2/\text{s}$ ; Table A-6, Water vapor (298 K):  $\nu_g = 44.25 \text{ m}^3/\text{kg}$ ,  $\rho_{A,\text{sat}} = 1/\nu_g = 0.0226 \text{ kg/m}^3$ ,  $h_{fg} = 2443 \text{ kJ/kg}$ ; Table A-8, Air-vapor (298 K):  $D_{AB} = 26 \times 10^{-6} \text{ m}^2/\text{s}$ ,  $Sc = \nu/D_{AB} = 0.60$ .

**ANALYSIS:** (a) If  $\rho_{A,m,o} = 0.99 \rho_{A,s}$ , it follows from Eq. 8.86 that

$$\frac{\rho_{A,s} - 0.99 \rho_{A,s}}{\rho_{A,s}} = 0.01 = \exp\left(-\frac{\pi DL \bar{h}_m}{\dot{m}}\right).$$

$$\text{With } Re_D = \frac{4 \dot{m}}{\pi D \mu} = \frac{4 \times 10^{-3} \text{ kg/s}}{\pi (0.02 \text{ m}) 183.6 \times 10^{-7} \text{ N}\cdot\text{s/m}^2} = 3467,$$

The flow is turbulent (weakly) and Eq. 8.88 yields

$$Sh_D = 0.023 Re_D^{4/5} Sc^{0.4} = 0.023 (3467)^{4/5} (0.60)^{0.4} = 12.7$$

$$h_m = \frac{Sh_D D_{AB}}{D} = \frac{12.7 \times 26 \times 10^{-6} \text{ m}^2/\text{s}}{0.02 \text{ m}} = 0.0166 \text{ m/s}.$$

Hence,

$$L = -\frac{\dot{m}}{\pi D \bar{h}_m} \ln(0.01) = -\frac{10^{-3} \text{ kg/s} \times \ln(0.01)}{\pi (0.02 \text{ m}) 1.17 \text{ kg/m}^3 (0.0166 \text{ m/s})} = 3.78 \text{ m}. \quad <$$

(b) The required heat rate is

$$q = n_A h_{fg} \quad n_A = \bar{h}_m \pi DL \frac{\Delta \rho_{A,o} - \Delta \rho_{A,i}}{\ln(\Delta \rho_{A,o} / \Delta \rho_{A,i})} \quad \text{with } \rho_{A,s} = \rho_{A,\text{sat}}$$

$$n_A = 0.0166 \text{ m/s} \times \pi (0.02 \text{ m}) 3.78 \text{ m} \frac{0.01 \rho_{A,s} - \rho_{A,s}}{\ln(0.01)}$$

$$n_A = -8.55 \times 10^{-4} \text{ m}^3/\text{s} \left( -0.99 \times 0.0226 \text{ kg/m}^3 \right) = 1.91 \times 10^{-5} \text{ kg/s}$$

$$q = n_A h_{fg} = 1.91 \times 10^{-5} \text{ kg/s} \times 2.443 \times 10^6 \text{ J/kg} = 46.7 \text{ W}. \quad <$$

**COMMENTS:** (1) The evaporation rate is low; hence the heat requirement is small. (2) The evaporation rate can also be calculated from

$n_A = \dot{m}(\rho_{A,o}/\rho - \rho_{A,i}/\rho) = \dot{m}/\rho(0.99\rho_{A,s}) = 1.91 \times 10^{-5} \text{ kg/s}$  which agrees with the preceding result.



### PROBLEM 8.127

**KNOWN:** Tube length, diameter and temperature. Air temperature and velocity. Saturation pressure of thin liquid film and properties of vapor.

**FIND:** (a) Partial pressure and mass fraction of vapor at tube exit, (b) Mass rate at which liquid is removed from the tube.

**SCHEMATIC:**

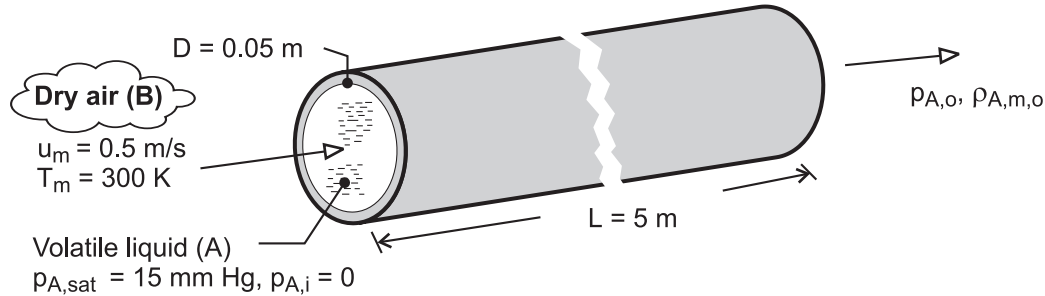

**ASSUMPTIONS:** (1) System is isothermal at 300K, (2) Steady, incompressible flow, (3) Perfect gas behavior, (4) Mass flow rate is independent of  $x$ .

**PROPERTIES:** Table A-4, Air (300 K, 1 atm):  $\rho = 1.16 \text{ kg/m}^3$ ,  $\nu = 15.9 \times 10^{-6} \text{ m}^2/\text{s}$ . Prescribed, Vapor (300K):  $p_{A,sat} = 15 \text{ mm Hg}$ ,  $\mathcal{M}_A = 70 \text{ kg/kmol}$ ,  $D_{AB} = 10^{-5} \text{ m}^2/\text{s}$ .

**ANALYSIS:** (a) With the vapor assumed to behave as an ideal gas,  $p_A = C_A \Re T = \rho_A (\Re / \mathcal{M}_A) T$ , and isothermal conditions, the vapor pressure at the outlet may be obtained from the expression

$$\frac{p_{A,sat} - p_{A,o}}{p_{A,sat} - p_{A,i}} = \frac{\rho_{A,s} - \rho_{A,m,o}}{\rho_{A,s} - \rho_{A,m,i}} = \exp\left(-\frac{\rho \pi D L \bar{h}_m}{\dot{m}}\right)$$

where  $\dot{m} = \rho u_m A_c = 1.16 \text{ kg/m}^3 \times 0.5 \text{ m/s} \times \pi (0.05 \text{ m})^2 / 4 = 1.14 \times 10^{-3} \text{ kg/s}$ . With  $\text{Re}_D = u_m D / \nu = 0.5 \text{ m/s} \times 0.05 \text{ m} / 15.9 \times 10^{-6} \text{ m}^2/\text{s} = 1570$ , the flow is laminar. From Eq. 8.3 and the mass transfer analogy to Eq. 8.23, with  $\text{Sc} = \nu / D_{AB} = 1.59$ ,

$$x_{fd,h} = 0.05 \text{Re}_D D = 0.05 \times 1570 \times 0.05 \text{ m} = 3.93 \text{ m}, \quad x_{fd,c} = x_{fd,h} \text{Sc} = 3.93 \text{ m} \times 1.59 = 6.24 \text{ m}$$

Thus this is a combined entry length situation and the mass transfer analogy to the Baehr and Stephan correlation, Eq. 8.58, is appropriate. By analogy to Eq. 8.57,  $Gz_{m,D} = (D/L)\text{Re}_D \text{Sc} = (0.05 \text{ m}/5 \text{ m}) \times 1570 \times 1.59 = 25.0$ , and

$$\begin{aligned} \bar{Sh}_D = \frac{\bar{h}_m D}{D_{AB}} &= \frac{3.66}{\tanh[2.264 Gz_{m,D}^{-1/3} + 1.7 Gz_{m,D}^{-2/3}] + 0.0499 Gz_{m,D} \tanh(Gz_{m,D}^{-1})} \\ &= \frac{3.66}{\tanh(2.432 \text{Sc}^{1/6} Gz_{m,D}^{-1/6})} = \frac{3.66}{\tanh[2.264 \times 25.0^{-1/3} + 1.7 \times 25.0^{-2/3}] + 0.0499 \times 25.0 \tanh(25.0^{-1})} \\ &= \frac{3.66}{\tanh(2.432 \times 1.59^{1/6} \times 25.0^{-1/6})} = 5.41 \end{aligned}$$

$$\bar{h}_m = \frac{\bar{Sh}_D D_{AB}}{D} = 5.41 \times \frac{10^{-5} \text{ m}^2/\text{s}}{0.05 \text{ m}} = 1.08 \times 10^{-3} \text{ m/s}$$

Hence, with  $p_{A,i} = 0$

Continued ...

**PROBLEM 8.127 (Cont.)**

$$p_{A,o} = p_{A,sat} \left[ 1 - \exp\left(-\frac{\rho \pi D L \bar{h}_m}{\dot{m}}\right) \right] = 15 \text{ mm Hg} \left[ 1 - \exp\left(-\frac{1.16 \text{ kg/m}^3 \times \pi \times 0.05 \text{ m} \times 5 \text{ m} \times 1.08 \times 10^{-3} \text{ m/s}}{1.14 \times 10^{-3} \text{ kg/s}}\right) \right] = 8.7 \text{ mm Hg} <$$

The corresponding mass density of the vapor is

$$\rho_{A,m,o} = \frac{p_{A,o} \mathcal{M}_A}{\mathcal{R}T} = \frac{8.7 \text{ mm Hg} \times 70 \text{ kg/kmol}}{(760 \text{ mm Hg/atm})(0.082 \text{ m}^3 \cdot \text{atm/kmol} \cdot \text{K})300 \text{ K}} = 0.0326 \text{ kg/m}^3 <$$

(b) The evaporation rate is

$$n_A = u_m A_c (\rho_{A,m,o} - \rho_{A,m,i}) = 0.5 \text{ m/s} \times 1.96 \times 10^{-3} \text{ m}^2 \times 0.0326 \text{ kg/m}^3 = 3.20 \times 10^{-5} \text{ kg/s} <$$

**COMMENTS:** (1) Since the evaporation rate ( $n_A = 3.2 \times 10^{-5} \text{ kg/s}$ ) is much less than the air flow rate ( $\dot{m} = 1.14 \times 10^{-3} \text{ kg/s}$ ), the assumption of a fixed flow rate is reasonable. (2) The evaporation rate is also given by  $n_A = \bar{h}_m \pi D L \Delta \rho_{A,m} = -\bar{h}_m \pi D L \rho_{A,m,o} / \ln [(p_{A,sat} - p_{A,o})/p_{A,sat}] = 3.22 \times 10^{-5} \text{ kg/s}$ , which agrees with the calculation of part (b).

## PROBLEM 8.128

**KNOWN:** Air flow rate through trachea of diameter  $D$  and length  $L$ .

**FIND:** (a) Average mass transfer convection coefficient,  $\bar{h}_m$ , and (b) Rate of water loss per day (liter/day).

**SCHEMATIC:**

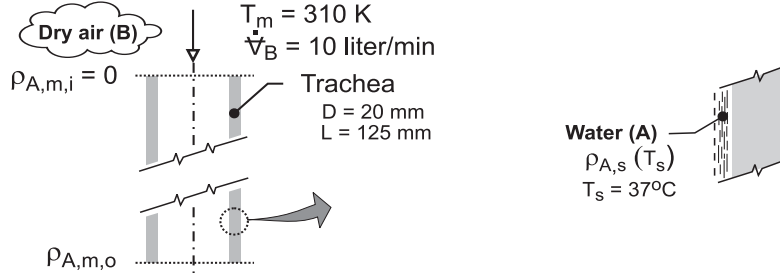

**ASSUMPTIONS:** (1) Trachea can be approximated as a smooth tube with uniform surface temperature, (2) Laminar, fully developed flow, (3) Trachea inner surface is saturated with water at body temperature,  $T_s = 37^\circ\text{C}$ , (4) Negligible water vapor in air at 310 K during inhalation, and (5) Heat-mass analogy is applicable.

**PROPERTIES:** Table A-4, Air (310 K, 1 atm):  $\rho_B = 1.128 \text{ kg/m}^3$ ,  $\mu = 1.893 \times 10^{-5} \text{ N}\cdot\text{s/m}^2$ ; Table A-6, Water ( $T_s = 37^\circ\text{C} = 310 \text{ K}$ ):  $\rho_{A,f} = 993 \text{ kg/m}^3$ ,  $\rho_{A,g} = 0.04361 \text{ kg/m}^3$ ; Table A-8, Water-vapor air (310 K, 1 atm):  $D_{AB} = 0.26 \times 10^{-4} (310/298)^{3/2} = 2.76 \times 10^{-5} \text{ m}^2/\text{s}$ .

**ANALYSIS:** (a) Begin by characterizing the air (B) flow in the trachea modeled as a smooth tube,

$$\text{Re}_D = \frac{4\dot{m}}{\pi D \mu} = \frac{4\dot{V}_B \rho_B}{\pi D \mu}$$

$$\text{Re}_D = \frac{4 \times 10 \text{ liter/min} \times 10^{-3} \text{ m}^3/\text{liter} \times 1 \text{ min}/60\text{s} \times 1.128 \text{ kg/m}^3}{\pi \times 0.020 \text{ m} \times 1.893 \times 10^{-5} \text{ N}\cdot\text{s/m}^2} = 632$$

Hence, the flow is laminar, and for fully developed conditions and invoking the heat-mass analogy

$$\text{Nu}_D = \text{Sh}_D = 3.66 \quad \text{Sh} = \bar{h}_m D / D_{AB}$$

$$\bar{h}_m = 3.66 D_{AB} / D = 3.66 \times 2.76 \times 10^{-5} \text{ m}^2/\text{s} / 0.020 \text{ m} = 0.0050 \text{ m/s} \quad <$$

(b) The species (A) transfer rate equation, Eq. 8.83, has the form

$$n_A = \bar{h}_m A_s \Delta\rho_{A,\ell m}$$

$$\Delta\rho_{A,\ell m} = \frac{(\rho_{A,s} - \rho_{A,m,o}) - (\rho_{A,s} - \rho_{A,m,i})}{\ell m \left[ (\rho_{A,s} - \rho_{A,m,o}) / (\rho_{A,s} - \rho_{A,m,i}) \right]}$$

where the mean outlet species density,  $\rho_{A,m,o}$ , can be determined from Eq. 8.86

$$\frac{\rho_{A,s} - \rho_{A,m,o}}{\rho_{A,s} - \rho_{A,m,i}} = \exp\left(-\frac{\bar{h}_m \rho P L}{\dot{m}}\right)$$

where  $\dot{m} / \rho = u_m A_c = \dot{V}_B$ . Substituting numerical values with  $P = \pi D$ , find

$$\rho_{A,m,o} = 0.009233 \quad n_A = 1.54 \times 10^{-6} \text{ kg/s}$$

The volumetric rate of water loss on a daily basis, assuming a 12 hour inhalation period, is

$$\dot{V}_A = \left(1.54 \times 10^{-6} \text{ kg/s} / 993 \text{ kg/m}^3\right) \times 10^3 \text{ liter/m}^3 \times (3600 \text{ s/h} \times 24 \text{ h/day})$$

$$\dot{V}_A = 0.134 \text{ liter/day}$$

### PROBLEM 8.129

**KNOWN:** Air (species B) is in fully developed, laminar flow as it enters a circular tube wetted with liquid A (water). Tube length and diameter. Flow rate of air and system temperature.

**FIND:** (a) Governing differential equation for species transfer, (b) Heat transfer analog and an expression for  $\overline{Sh}_D$ , (c) General expression for  $\rho_{A,m,o}$ , (d) Value of  $\rho_{A,m,o}$  for prescribed conditions.

**SCHEMATIC:**

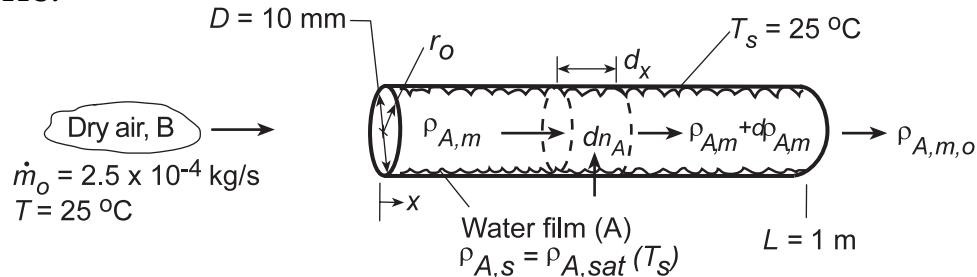

**ASSUMPTIONS:** (1) Steady, incompressible flow, (2) Flow rate is independent of  $x$ , (3) Laminar, fully developed flow (hydrodynamically), (4) Isothermal conditions, (5) Dry air at inlet.

**PROPERTIES:** Table A.4, Air (298 K, 1 atm):  $\rho = 1.1707 \text{ kg/m}^3$ ,  $\mu = 183.6 \times 10^{-7} \text{ N}\cdot\text{s/m}^2$ ,  $\nu = 15.71 \times 10^{-6} \text{ m}^2/\text{s}$ ; Table A.6, Water vapor (298 K):  $\rho_{A,sat} = 1/\nu_g = 0.0266 \text{ kg/m}^3$ ; Table A.8, Air-vapor (298 K):  $D_{AB} = 26 \times 10^{-6} \text{ m}^2/\text{s}$ ,  $Sc = \nu/D_{AB} = 0.60$ .

**ANALYSIS:** (a) The governing differential equation may be inferred by analogy to Eq. 8.48. In this case, the dependent variable is the vapor mass density,  $\rho_A(x,r)$ , and the diffusivity is  $D_{AB}$ . It follows that

$$u \frac{\partial \rho_A}{\partial x} = \frac{D_{AB}}{r} \frac{\partial}{\partial r} \left( r \frac{\partial \rho_A}{\partial r} \right) \quad <$$

The entrance condition is

$$\rho_A(0, r) = 0 \quad <$$

and the boundary conditions are

$$\rho_A(r_o, x) = \rho_{A,s} \quad \rho_A|_{r=0} \text{ is finite} \quad <$$

(b) The foregoing conditions are analogous to those of the thermal entry length condition associated with Eq. 8.57. Invoking this analogy the average Sherwood number for laminar, fully developed flow is

$$\overline{Sh}_D = 3.66 + \frac{0.0668(D/L) Re_D Sc}{1 + 0.04[(D/L) Re_D Sc]^{2/3}} \quad <$$

where the mass transfer analogy to Eq. 8.56 was used for the Graetz number.

(c) Applying conservation of species to the differential control volume,

$$\rho_{A,m} u_m A_c + dn_A = \left( \rho_{A,m} + \frac{d\rho_{A,m}}{dx} dx \right) u_m A_c$$

or, with  $u_m A_c = \dot{m}/\rho$  and  $dn_A = h_m \pi D dx (\rho_{A,s} - \rho_{A,m})$

$$\frac{\dot{m}}{\rho} \frac{d\rho_{A,m}}{dx} dx = h_m \pi D dx (\rho_{A,s} - \rho_{A,m})$$

Continued...

**PROBLEM 8.129 (Cont.)**

$$\int_{\rho_{A,m,i}}^{\rho_{A,m}} \frac{d\rho_{A,m}}{\rho_{A,s} - \rho_{A,m}} = \int_0^x \frac{\rho\pi D h_m}{\dot{m}} dx$$

or

$$\frac{\rho_{A,s} - \rho_{A,m}(x)}{\rho_{A,s} - \rho_{A,m,i}} = \exp\left(-\frac{\rho\pi D x \bar{h}_m(x)}{\dot{m}}\right)$$

at  $x = L$ ,

$$\frac{\rho_{A,s} - \rho_{A,m,o}}{\rho_{A,s} - \rho_{A,m,i}} = \exp\left(-\frac{\rho\pi D L \bar{h}_m}{\dot{m}}\right) \quad <$$

(d) For the prescribed conditions,  $Re_D = 4\dot{m}/\pi D \mu = 4(2.5 \times 10^{-4} \text{ kg/s})/\pi(0.01 \text{ m})183.6 \times 10^{-7} \text{ N}\cdot\text{s}/\text{m}^2 = 1734$  and  $(D/L)Re_D Sc = (0.01 \text{ m}/1 \text{ m})1734(0.6) = 10.4$ . Hence,

$$\bar{Sh}_D = 3.66 + \frac{0.0668(10.4)}{1 + 0.04(10.4)^{2/3}} = 4.24$$

$$\bar{h}_m = \bar{Sh}_D (D_{AB}/D) = 4.24(26 \times 10^{-6} \text{ m}^2/\text{s}/0.01 \text{ m}) = 0.011 \text{ m/s}$$

Hence,

$$\frac{\rho_{A,s} - \rho_{A,m,o}}{\rho_{A,s} - \rho_{A,m,i}} = \exp\left(-\frac{1.1707 \text{ kg}/\text{m}^3 \times \pi \times 0.01 \text{ m} \times 1 \text{ m} \times 0.011 \text{ m/s}}{2.5 \times 10^{-4} \text{ kg/s}}\right) = 0.198$$

$$\rho_{A,m,o} = \rho_{A,s} - 0.198(\rho_{A,s} - \rho_{A,m,i}) = 0.0226 \text{ kg}/\text{m}^3 (1 - 0.198) = 0.0181 \text{ kg}/\text{m}^3 <$$

**COMMENTS:** Due to evaporation,  $\dot{m}$  actually increases with increasing  $x$ . However, the increase is small, and the assumption of fixed  $\dot{m}$  is good.

## PROBLEM 9.1

**KNOWN:** Thickness and thermal conductivity of plane wall. Fluid temperatures.

**FIND:** Expected minimum and maximum steady-state heat fluxes through the wall for (a) free convection in gases, (b) free convection in liquids, (c) forced convection in gases, (d) forced convection in liquids, and (e) convection with phase change.

**SCHEMATIC:**

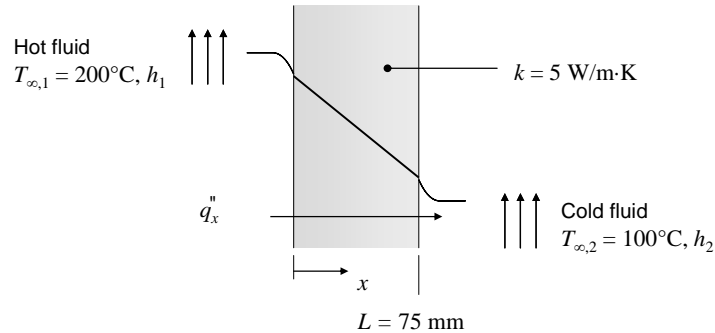

**ASSUMPTIONS:** (1) Constant properties. (2) Steady state conditions. (3) Negligible radiation.

**ANALYSIS:** The thermal resistance network is

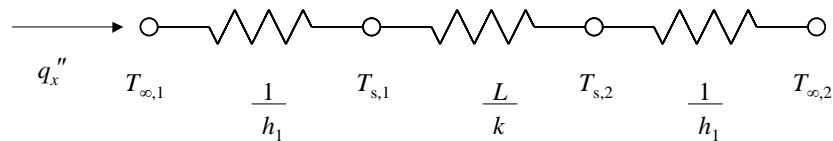

From Table 1.1 for free convection in gases, the minimum convective heat transfer coefficient is  $h = 2 \text{ W/m}^2\cdot\text{K}$ . Therefore, the corresponding heat flux is

$$q_x'' = \frac{T_{\infty,1} - T_{\infty,2}}{\frac{1}{h_1} + \frac{L}{k} + \frac{1}{h_2}} = \frac{200^\circ\text{C} - 100^\circ\text{C}}{\frac{1}{2 \text{ W/m}^2 \cdot \text{K}} + \frac{75 \times 10^{-3} \text{ m}}{5 \text{ W/m} \cdot \text{K}} + \frac{1}{2 \text{ W/m}^2 \cdot \text{K}}} = 98.5 \text{ W/m}^2$$

Proceeding in the same manner, we find the following results

Process	$h_{\min} \text{ (W/m}^2\cdot\text{K)}$	$h_{\max} \text{ (W/m}^2\cdot\text{K)}$	$q_{x,\min}''$	$q_{x,\max}''$	$q_{x,\max}'' / q_{x,\min}''$	
(a) Free convection, gas	2	25	98.5	1053	10.7	<
(b) Free convection, liquid	50	1000	1818	5882	3.23	<
(c) Forced convection, gas	25	250	1053	4348	4.12	<
(d) Forced convection, liquid	100	20,000	2857	6623	2.32	<
(e) Phase change	2500	100,000	6329	6658	1.05	<

**COMMENTS:** For either gases or liquids, the dependence of the heat flux on the range of convection coefficients associated with each type of convective heat transfer process, as quantified by the ratio  $q_{x,\max}'' / q_{x,\min}''$ , is strongest for free convection, and weakest for convection involving phase change. The temptation to attach less significance to free convection because the convection coefficients are small is to be resisted. Free convection poses large thermal resistance, and therefore can be the dominant factor in thermal engineering processes and design.

## PROBLEM 9.2

**KNOWN:** Tabulated values of density for water and definition of the volumetric thermal expansion coefficient,  $\beta$ .

**FIND:** Value of the volumetric expansion coefficient at 300K; compare with tabulated values.

**PROPERTIES:** *Table A-6, Water (300K):*  $\rho = 1/v_f = 1/1.003 \times 10^{-3} \text{ m}^3/\text{kg} = 997.0 \text{ kg/m}^3$ ,  $\beta = 276.1 \times 10^{-6} \text{ K}^{-1}$ ; (295K):  $\rho = 1/v_f = 1/1.002 \times 10^{-3} \text{ m}^3/\text{kg} = 998.0 \text{ kg/m}^3$ ; (305K):  $\rho = 1/v_f = 1/1.005 \times 10^{-3} \text{ m}^3/\text{kg} = 995.0 \text{ kg/m}^3$ .

**ANALYSIS:** The volumetric expansion coefficient is defined by Eq. 9.4 as

$$\beta = -\frac{1}{\rho} \left( \frac{\partial \rho}{\partial T} \right)_p.$$

The density change with temperature at constant pressure can be estimated as

$$\left( \frac{\partial \rho}{\partial T} \right)_p \approx \left( \frac{\rho_1 - \rho_2}{T_1 - T_2} \right)_p$$

where the subscripts (1,2) denote the property values just above and below, respectively, the condition for  $T = 300\text{K}$  denoted by the subscript (o). That is,

$$\beta_o \approx -\frac{1}{\rho_o} \left( \frac{\rho_1 - \rho_2}{T_1 - T_2} \right)_p.$$

Substituting numerical values, find

$$\beta_o \approx \frac{-1}{997.0 \text{ kg/m}^3} \frac{(995.0 - 998.0) \text{ kg/m}^3}{(305 - 295) \text{ K}} = 300.9 \times 10^{-6} \text{ K}^{-1}. \quad <$$

Compare this value with the tabulation,  $\beta = 276.1 \times 10^{-6} \text{ K}^{-1}$ , to find our estimate is 8.7% high.

**COMMENTS:** (1) The poor agreement between our estimate and the tabulated value is due to the poor precision with which the density change with temperature is estimated. The tabulated values of  $\beta$  were determined from accurate equation of state data.

(2) Note that  $\beta$  is negative for  $T < 275\text{K}$ . Why? What is the implication for free convection?

### PROBLEM 9.3

**KNOWN:** Relation for the Rayleigh number.

**FIND:** Rayleigh number for four fluids for prescribed conditions.

**SCHEMATIC:**

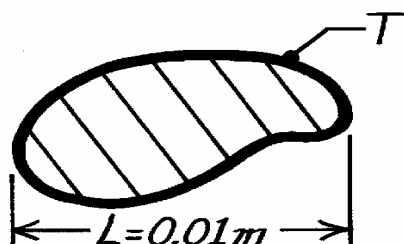

Quiescent  
fluid,  $T_\infty$   
 $\Delta T = 30^\circ\text{C}$   
 $L = 0.01\text{m}$

**ASSUMPTIONS:** (1) Perfect gas behavior for specified gases.

**PROPERTIES:** Table A-4, Air (400K, 1 atm):  $\nu = 26.41 \times 10^{-6} \text{ m}^2/\text{s}$ ,  $\alpha = 38.3 \times 10^{-6} \text{ m}^2/\text{s}$ ,  $\beta = 1/T = 1/400\text{K} = 2.50 \times 10^{-3} \text{ K}^{-1}$ ; Table A-4, Helium (400K, 1 atm):  $\nu = 199 \times 10^{-6} \text{ m}^2/\text{s}$ ,  $\alpha = 295 \times 10^{-6} \text{ m}^2/\text{s}$ ,  $\beta = 1/T = 2.50 \times 10^{-3} \text{ K}^{-1}$ ; Table A-5, Glycerin (12°C = 285K):  $\nu = 2830 \times 10^{-6} \text{ m}^2/\text{s}$ ,  $\alpha = 0.964 \times 10^{-7} \text{ m}^2/\text{s}$ ,  $\beta = 0.475 \times 10^{-3} \text{ K}^{-1}$ ; Table A-6, Water (37°C = 310K, sat. liq.):  $\nu = \mu_f \nu_f = 695 \times 10^{-6} \text{ N}\cdot\text{s}/\text{m}^2 \times 1.007 \times 10^{-3} \text{ m}^3/\text{kg} = 0.700 \times 10^{-6} \text{ m}^2/\text{s}$ ,  $\alpha = k_f \nu_f / c_{p,f} = 0.628 \text{ W}/\text{m}\cdot\text{K} \times 1.007 \times 10^{-3} \text{ m}^3/\text{kg} / 4178 \text{ J}/\text{kg}\cdot\text{K} = 0.151 \times 10^{-6} \text{ m}^2/\text{s}$ ,  $\beta_f = 361.9 \times 10^{-6} \text{ K}^{-1}$ .

**ANALYSIS:** The Rayleigh number, a dimensionless parameter used in free convection analysis, is defined as the product of the Grashof and Prandtl numbers.

$$\text{Ra}_L \equiv \text{Gr} \cdot \text{Pr} = \frac{g\beta\Delta T L^3}{\nu^2} \frac{\mu c_p}{k} = \frac{g\beta\Delta T L^3}{\nu^2} \frac{(\nu\rho)c_p}{k} = \frac{g\beta\Delta T L^3}{\nu\alpha}$$

where  $\alpha = k/\rho c_p$  and  $\nu = \mu/\rho$ . The numerical values for the four fluids follow:

*Air* (400K, 1 atm)

$$\text{Ra}_L = 9.8\text{m}/\text{s}^2 (1/400\text{K}) 30\text{K} (0.01\text{m})^3 / 26.41 \times 10^{-6} \text{ m}^2/\text{s} \times 38.3 \times 10^{-6} \text{ m}^2/\text{s} = 727 <$$

*Helium* (400K, 1 atm)

$$\text{Ra}_L = 9.8\text{m}/\text{s}^2 (1/400\text{K}) 30\text{K} (0.01\text{m})^3 / 199 \times 10^{-6} \text{ m}^2/\text{s} \times 295 \times 10^{-6} \text{ m}^2/\text{s} = 12.5 <$$

*Glycerin* (285K)

$$\text{Ra}_L = 9.8\text{m}/\text{s}^2 (0.475 \times 10^{-3} \text{ K}^{-1}) 30\text{K} (0.01\text{m})^3 / 2830 \times 10^{-6} \text{ m}^2/\text{s} \times 0.964 \times 10^{-7} \text{ m}^2/\text{s} = 512 <$$

*Water* (310K)

$$\text{Ra}_L = 9.8\text{m}/\text{s}^2 (0.362 \times 10^{-3} \text{ K}^{-1}) 30\text{K} (0.01\text{m})^3 / 0.700 \times 10^{-6} \text{ m}^2/\text{s} \times 0.151 \times 10^{-6} \text{ m}^2/\text{s} = 1.01 \times 10^6 <$$

**COMMENTS:** (1) Note the wide variation in values of Ra for the four fluids. A large value of Ra implies enhanced free convection, however, other properties affect the value of the heat transfer coefficient.



### PROBLEM 9.4

**KNOWN:** Form of the Nusselt number correlation for natural convection and fluid properties.

**FIND:** Expression for figure of merit  $F_N$  and values for air, water and a dielectric liquid.

**PROPERTIES:** Prescribed. Air:  $k = 0.026 \text{ W/m}\cdot\text{K}$ ,  $\beta = 0.0035 \text{ K}^{-1}$ ,  $\nu = 1.5 \times 10^{-5} \text{ m}^2/\text{s}$ ,  $\text{Pr} = 0.70$ .

Water:  $k = 0.600 \text{ W/m}\cdot\text{K}$ ,  $\beta = 2.7 \times 10^{-4} \text{ K}^{-1}$ ,  $\nu = 10^{-6} \text{ m}^2/\text{s}$ ,  $\text{Pr} = 5.0$ . Dielectric liquid:  $k = 0.064$

$\text{W/m}\cdot\text{K}$ ,  $\beta = 0.0014 \text{ K}^{-1}$ ,  $\nu = 10^{-6} \text{ m}^2/\text{s}$ ,  $\text{Pr} = 25$

**ANALYSIS:** With  $\text{Nu}_L \sim \text{Ra}^n$ , the convection coefficient may be expressed as

$$h \sim \frac{k}{L} \left( \frac{g\beta\Delta T L^3}{\alpha\nu} \right)^n \sim \frac{(g\Delta T L^3)^n}{L} \left( \frac{k\beta^n}{\alpha^n \nu^n} \right)$$

The figure of merit is therefore

$$F_N = \frac{k\beta^n}{\alpha^n \nu^n} \quad <$$

and for the three fluids, with  $n = 0.33$  and  $\alpha = \nu / \text{Pr}$ ,

$$F_N \left( \text{W}\cdot\text{s}^{2/3} / \text{m}^{7/3} \cdot \text{K}^{4/3} \right) \quad \begin{array}{ccc} \text{Air} & \text{Water} & \text{Dielectric} \\ \hline 5.8 & 663 & 209 \end{array} \quad <$$

Water is clearly the superior heat transfer fluid, while air is the least effective.

**COMMENTS:** The figure of merit indicates that heat transfer is enhanced by fluids of large  $k$ , large  $\beta$  and small values of  $\alpha$  and  $\nu$ .

## PROBLEM 9.5

**KNOWN:** Temperature and pressure of air in a free convection application.

**FIND:** Figure of merit for  $T = 27^\circ\text{C}$  and  $P = 1, 10$  and  $100$  bar.

**ASSUMPTIONS:** (1) Ideal gas, (2) Thermal conductivity, dynamic viscosity and specific heat are independent of pressure.

**PROPERTIES:** Table A.4, air: ( $T_f = 300$  K,  $p = 1$  atm):  $k = 0.0263$  W/m·K,  $c_p = 1007$  J/kg·K,  $\nu = 15.89 \times 10^{-6}$  m<sup>2</sup>/s,  $\alpha = 22.5 \times 10^{-6}$  m<sup>2</sup>/s.

**ANALYSIS:** With  $\text{Nu}_L \approx \text{Ra}^n$ , the convection coefficient may be expressed as

$$h \approx \frac{k}{L} \left( \frac{g\beta\Delta TL^3}{\alpha\nu} \right)^n = \frac{(g\Delta TL^3)^n}{L} \left( \frac{k\beta^n}{\alpha^n\nu^n} \right)$$

and the figure of merit is  $F_N = \frac{k\beta^n}{\alpha^n\nu^n}$ .

For an ideal gas,  $\beta = 1/T$ . The thermal diffusivity is  $\alpha = k/\rho c_p$ . Since  $k$  and  $c_p$  are independent of pressure, and the density is proportional to pressure for an ideal gas,  $\alpha \propto 1/p$ . The kinematic viscosity is  $\nu = \mu/\rho$ . Therefore, for an ideal gas,  $\nu \propto 1/p$ . Thus, the properties and the figure of merit, using  $n = 0.33$ , at the three pressures are

$p = 1 \text{ bar} = 1 \times 10^5 \text{ N/m}^2$	$p = 10 \text{ bar}$	$p = 100 \text{ bar}$
$\beta = 1/300 \text{ K}^{-1}$	$\beta = 1/300 \text{ K}^{-1}$	$\beta = 1/300 \text{ K}^{-1}$
$k = 0.0263 \text{ W/m}\cdot\text{K}$	$k = 0.0263 \text{ W/m}\cdot\text{K}$	$k = 0.0263 \text{ W/m}\cdot\text{K}$
$\alpha = 22.5 \times 10^{-6} \text{ m}^2/\text{s} \times \left( \frac{1.0133}{1} \right)$	$\alpha = 22.5 \times 10^{-6} \text{ m}^2/\text{s} \times \left( \frac{1.0133}{10} \right)$	$\alpha = 22.5 \times 10^{-6} \text{ m}^2/\text{s} \times \left( \frac{1.0133}{100} \right)$
$= 2.28 \times 10^{-5} \text{ m}^2/\text{s}$	$= 2.28 \times 10^{-6} \text{ m}^2/\text{s}$	$= 2.28 \times 10^{-7} \text{ m}^2/\text{s}$
$\nu = 1.589 \times 10^{-5} \text{ m}^2/\text{s} \times \left( \frac{1.0133}{1} \right)$	$\nu = 1.589 \times 10^{-5} \text{ m}^2/\text{s} \times \left( \frac{1.0133}{10} \right)$	$\nu = 1.589 \times 10^{-5} \text{ m}^2/\text{s} \times \left( \frac{1.0133}{100} \right)$
$= 1.610 \times 10^{-5} \text{ m}^2/\text{s}$	$= 1.610 \times 10^{-6} \text{ m}^2/\text{s}$	$= 1.610 \times 10^{-7} \text{ m}^2/\text{s}$

Therefore, for  $P = 1$  bar,  $F_N = \frac{0.0263 \text{ W/m}\cdot\text{K} \times (1/300\text{K})^{0.33}}{(2.28 \times 10^{-5} \text{ m}^2/\text{s})^{0.33} \times (1.61 \times 10^{-5} \text{ m}^2/\text{s})^{0.33}} = 5.20$ . Similarly, for

$P = 10$  bar,  $F_N = 23.78$  while for  $P = 100$  bar,  $F_N = 108.7$ . <

**COMMENT:** The efficacy of natural convection cooling within sealed enclosures can be increased significantly by increasing the pressure of the gas.

## PROBLEM 9.6

**KNOWN:** Heat transfer rate by convection from a vertical surface, 1m high by 0.6m wide, to quiescent air that is 20K cooler.

**FIND:** Ratio of the heat transfer rate for the above case to that for a vertical surface that is 0.6m high by 1m wide with quiescent air that is 20K warmer.

**SCHEMATIC:**

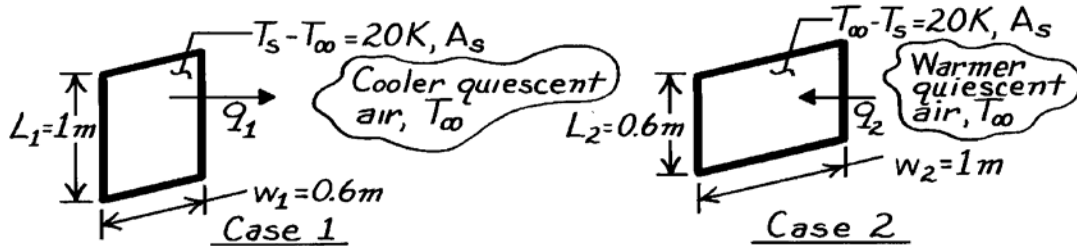

**ASSUMPTIONS:** (1) Thermophysical properties independent of temperature; evaluate at 300K; (2) Negligible radiation exchange with surroundings, (3) Quiescent ambient air.

**PROPERTIES:** Table A-4, Air (300K, 1 atm):  $\nu = 15.89 \times 10^{-6} \text{ m}^2/\text{s}$ ,  $\alpha = 22.5 \times 10^{-6} \text{ m}^2/\text{s}$ .

**ANALYSIS:** The rate equation for convection between the plates and quiescent air is

$$q = \bar{h}_L A_S \Delta T \quad (1)$$

where  $\Delta T$  is either  $(T_s - T_\infty)$  or  $(T_\infty - T_s)$ ; for both cases,  $A_S = Lw$ . The desired heat transfer ratio is then

$$\frac{q_1}{q_2} = \frac{\bar{h}_{L1}}{\bar{h}_{L2}} \quad (2)$$

To determine the dependence of  $\bar{h}_L$  on geometry, first calculate the Rayleigh number,

$$\text{Ra}_L = g \beta \Delta T L^3 / \nu \alpha \quad (3)$$

and substituting property values at 300K, find,

$$\text{Case 1: } \text{Ra}_{L1} = 9.8 \text{ m/s}^2 (1/300\text{K}) 20\text{K} (1\text{m})^3 / 15.89 \times 10^{-6} \text{ m}^2/\text{s} \times 22.5 \times 10^{-6} \text{ m}^2/\text{s} = 1.82 \times 10^9$$

$$\text{Case 2: } \text{Ra}_{L2} = \text{Ra}_{L1} (L_2/L_1)^3 = 1.82 \times 10^4 (0.6\text{m}/1.0\text{m})^3 = 3.94 \times 10^8$$

Hence, Case 1 is turbulent and Case 2 is laminar. Using the correlation of Eq. 9.24,

$$\overline{\text{Nu}}_L = \frac{\bar{h}_L L}{k} = C (\text{Ra}_L)^n \quad \bar{h}_L = \frac{k}{L} C \text{Ra}_L^n \quad (4)$$

where for Case 1:  $C_1 = 0.10$ ,  $n_1 = 1/3$  and for Case 2:  $C_2 = 0.59$ ,  $n_2 = 1/4$ . Substituting Eq. (4) into the ratio of Eq. (2) with numerical values, find

$$\frac{q_1}{q_2} = \frac{(C_1/L_1) \text{Ra}_{L1}^{n_1}}{(C_2/L_2) \text{Ra}_{L2}^{n_2}} = \frac{(0.10/1\text{m}) (1.82 \times 10^9)^{1/3}}{(0.59/0.6\text{m}) (3.94 \times 10^8)^{1/4}} = 0.881 <$$

**COMMENTS:** Is this result to be expected? How do you explain this effect of plate orientation on the heat rates?

## PROBLEM 9.7

**KNOWN:** Large vertical plate with uniform surface temperature of 130°C suspended in quiescent air at 25°C and atmospheric pressure.

**FIND:** (a) Boundary layer thickness at 0.25 m from lower edge, (b) Maximum velocity in boundary layer at this location and position of maximum, (c) Heat transfer coefficient at this location, (d) Location where boundary layer becomes turbulent.

**SCHEMATIC:**

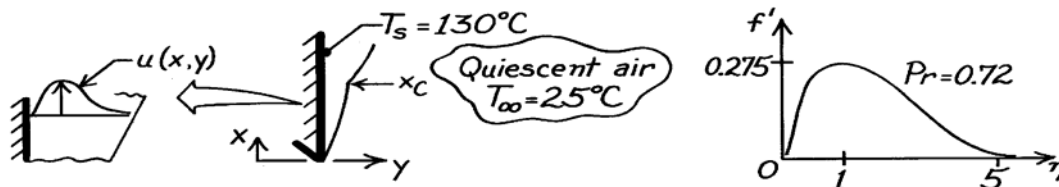

**ASSUMPTIONS:** (1) Isothermal, vertical surface in an extensive, quiescent medium, (2) Boundary layer assumptions valid.

**PROPERTIES:** Table A-4, Air ( $T_f = (T_s + T_\infty)/2 = 350\text{K}$ , 1 atm):  $\nu = 20.92 \times 10^{-6} \text{ m}^2/\text{s}$ ,  $k = 0.030 \text{ W/m}\cdot\text{K}$ ,  $Pr = 0.700$ .

**ANALYSIS:** (a) From the similarity solution results, Fig. 9.4 (see above right), the boundary layer thickness corresponds to a value of  $\eta \approx 5$ . From Eqs. 9.13 and 9.12,

$$y = \eta x (\text{Gr}_x / 4)^{-1/4} \quad (1)$$

$$\text{Gr}_x = g\beta(T_s - T_\infty)x^3 / \nu^2 = 9.8 \frac{\text{m}}{\text{s}^2} \times \frac{1}{350\text{K}} (130 - 25)\text{K} x^3 / \left(20.92 \times 10^{-6} \text{ m}^2/\text{s}\right)^2 = 6.718 \times 10^9 x^3 \quad (2)$$

$$y \approx 5(0.25\text{m}) \left(6.718 \times 10^9 (0.25)^3 / 4\right)^{-1/4} = 1.746 \times 10^{-2} \text{ m} = 17.5 \text{ mm}. \quad (3) <$$

(b) From the similarity solution shown above, the maximum velocity occurs at  $\eta \approx 1$  with  $f'(\eta) = 0.275$ . From Eq. 9.15, find

$$u = \frac{2\nu}{x} \text{Gr}_x^{1/2} f'(\eta) = \frac{2 \times 20.92 \times 10^{-6} \text{ m}^2/\text{s}}{0.25\text{m}} \left(6.718 \times 10^9 (0.25)^3\right)^{1/2} \times 0.275 = 0.47 \text{ m/s}. <$$

The maximum velocity occurs at a value of  $\eta = 1$ ; using Eq. (3), it follows that this corresponds to a position in the boundary layer given as

$$y_{\text{max}} = 1/5 (17.5 \text{ mm}) = 3.5 \text{ mm}. <$$

(c) From Eq. 9.19, the local heat transfer coefficient at  $x = 0.25 \text{ m}$  is

$$\text{Nu}_x = h_x x / k = (\text{Gr}_x / 4)^{1/4} g(Pr) = \left(6.718 \times 10^9 (0.25)^3 / 4\right)^{1/4} 0.50 = 35.7$$

$$h_x = \text{Nu}_x k / x = 35.7 \times 0.030 \text{ W/m}\cdot\text{K} / 0.25 \text{ m} = 4.3 \text{ W/m}^2 \cdot \text{K}. <$$

The value for  $g(Pr)$  is determined from Eq. 9.20 with  $Pr = 0.700$ .

(d) According to Eq. 9.23, the boundary layer becomes turbulent at  $x_c$  given as

$$\text{Ra}_{x,c} = \text{Gr}_{x,c} Pr \approx 10^9 \quad x_c \approx \left[10^9 / 6.718 \times 10^9 (0.700)\right]^{1/3} = 0.60 \text{ m}. <$$

**COMMENTS:** Note that  $\beta = 1/T_f$  is a suitable approximation for air.

## PROBLEM 9.8

**KNOWN:** Laminar free convection on a vertical plate.

**FIND:** Exact values of  $C$  from the similarity solution for  $Pr = 0.01, 1, 10$  and  $100$ .

**ASSUMPTIONS:** (1) Constant properties. (2) Steady state conditions. (3) Parameter  $n = 1/4$ .

**ANALYSIS:** The similarity solution for the average Nusselt number is

$$\overline{Nu}_L = \frac{4}{3} \left( \frac{Gr_L}{4} \right)^{1/4} \left[ \frac{0.75 Pr^{1/2}}{\left( 0.609 + 1.221 Pr^{1/2} + 1.238 Pr \right)^{1/4}} \right] \quad (1)$$

while the correlation for the average Nusselt number is expressed as

$$\overline{Nu}_L = C Ra_L^n = C (Gr_L \cdot Pr)^n = C (Gr_L \cdot Pr)^{1/4} \quad (2)$$

Equating the preceding two expressions yields

$$C = \frac{4}{3} \left( \frac{1}{4} \right)^{1/4} \left[ \frac{0.75 Pr^{1/4}}{\left( 0.609 + 1.221 Pr^{1/2} + 1.238 Pr \right)^{1/4}} \right] \quad (3)$$

Values of  $C$  may be determined by substituting  $Pr = 0.01, 1, 10$  and  $100$  into Equation 3.

$Pr$	$C$
0.01	0.241
1	0.534
10	0.621
100	0.654

**COMMENTS:** (1) The correlation should not be used for liquid metals (i.e. low  $Pr$  fluids). (2) The average value of  $C$  for  $Pr = 1, 10$  and  $100$  is  $0.60 \approx 0.59$ . Use of the correlation for  $Pr \geq 0.7$  results in an error of approximately 10% as compared to the similarity solution. (3) There are few if any fluids characterized by  $Pr \approx 0.1$ . Hence, this range of the Prandtl numbers is not included in the comparison, and is omitted from Figure 9.4.

## PROBLEM 9.9

**KNOWN:** Dimensions of vertical rectangular fins. Temperature of fins and quiescent air.

**FIND:** (a) Optimum fin spacing, (b) Rate of heat transfer from an array of fins at the optimal spacing.

**SCHEMATIC:**

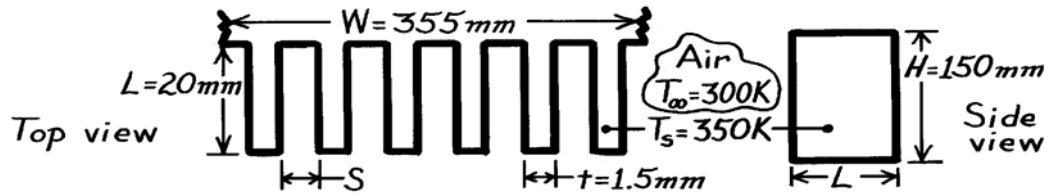

**ASSUMPTIONS:** (1) Fins are isothermal, (2) Radiation effects are negligible, (3) Air is quiescent.

**PROPERTIES:** Table A-4, Air ( $T_f = 325\text{K}$ , 1 atm):  $\nu = 18.41 \times 10^{-6} \text{ m}^2/\text{s}$ ,  $k = 0.0282 \text{ W/m}\cdot\text{K}$ ,  $\text{Pr} = 0.703$ .

**ANALYSIS:** (a) If fins are too close, boundary layers on adjoining surfaces will coalesce and heat transfer will decrease. If fins are too far apart, the surface area becomes too small and heat transfer decreases.  $S_{\text{op}} \approx \delta_{x=H}$ . From Fig. 9.4, the edge of boundary layer corresponds to

$$\eta = (\delta/H) (\text{Gr}_H/4)^{1/4} \approx 5.$$

$$\text{Hence, } \text{Gr}_H = \frac{g\beta(T_s - T_\infty)H^3}{\nu^2} = \frac{9.8 \text{ m/s}^2 (1/325\text{K}) 50\text{K} (0.15\text{m})^3}{(18.41 \times 10^{-6} \text{ m}^2/\text{s})^2} = 1.5 \times 10^7$$

$$\delta(H) = 5(0.15\text{m}) / \left(1.5 \times 10^7 / 4\right)^{1/4} = 0.017\text{m} = 17\text{mm} \quad S_{\text{op}} \approx 34\text{mm}. \quad <$$

(b) The number of fins  $N$  can be found as

$$N = W / (S_{\text{op}} + t) = 355 / 35.5 = 10$$

and the rate is  $q = 2 N \bar{h} (H \cdot L) (T_s - T_\infty)$ .

For laminar flow conditions

$$\overline{\text{Nu}}_H = 0.68 + 0.67 \text{ Ra}_L^{1/4} / \left[1 + (0.492/\text{Pr})^{9/16}\right]^{4/9}$$

$$\overline{\text{Nu}}_H = 0.68 + 0.67 \left(1.5 \times 10^7 \times 0.703\right)^{1/4} / \left[1 + (0.492/0.703)^{9/16}\right]^{4/9} = 30$$

$$\bar{h} = k \text{ Nu}_H / H = 0.0282 \text{ W/m}\cdot\text{K} (30) / 0.15 \text{ m} = 5.6 \text{ W/m}^2 \cdot \text{K}$$

$$q = 2(10) 5.6 \text{ W/m}^2 \cdot \text{K} (0.15\text{m} \times 0.02\text{m}) (350 - 300)\text{K} = 16.8 \text{ W}. \quad <$$

**COMMENTS:** Part (a) result is a conservative estimate of the optimum spacing. The increase in area resulting from a further reduction in  $S$  would more than compensate for the effect of fluid entrapment due to boundary layer merger. From a more rigorous treatment (see Section 9.7.1),  $S_{\text{op}} \approx 10 \text{ mm}$  is obtained for the prescribed conditions.

### PROBLEM 9.10

**KNOWN:** Thin, vertical plates of length 0.15m at 54°C being cooled in a water bath at 20°C.

**FIND:** Minimum spacing between plates such that no interference will occur between free-convection boundary layers.

**SCHEMATIC:**

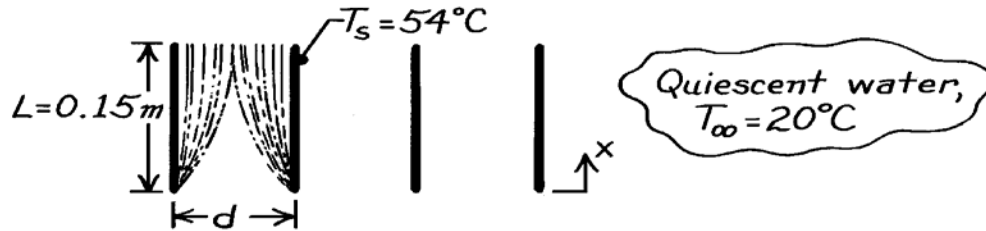

**ASSUMPTIONS:** (a) Water in bath is quiescent, (b) Plates are at uniform temperature.

**PROPERTIES:** Table A-6, Water ( $T_f = (T_s + T_\infty)/2 = (54 + 20)^\circ\text{C}/2 = 310\text{K}$ ):  $\rho = 1/v_f = 993.05 \text{ kg/m}^3$ ,  $\mu = 695 \times 10^{-6} \text{ N}\cdot\text{s/m}^2$ ,  $\nu = \mu/\rho = 6.998 \times 10^{-7} \text{ m}^2/\text{s}$ ,  $\text{Pr} = 4.62$ ,  $\beta = 361.9 \times 10^{-6} \text{ K}^{-1}$ .

**ANALYSIS:** The minimum separation distance will be twice the thickness of the boundary layer at the trailing edge where  $x = 0.15\text{m}$ . Assuming laminar, free convection boundary layer conditions, the similarity parameter,  $\eta$ , given by Eq. 9.13, is

$$\eta = \frac{y}{x} (\text{Gr}_x / 4)^{1/4}$$

where  $y$  is measured normal to the plate (see Fig. 9.3). According to Fig. 9.4, the boundary layer thickness occurs at a value  $\eta \approx 5$ .

It follows then that,

$$y_{bl} = \eta x (\text{Gr}_x / 4)^{-1/4}$$

$$\text{where } \text{Gr}_x = \frac{g \beta (T_s - T_\infty) x^3}{\nu^2}$$

$$\text{Gr}_x = 9.8 \text{ m/s}^2 \times 361.9 \times 10^{-6} \text{ K}^{-1} (54 - 20) \text{ K} \times (0.15 \text{ m})^3 / (6.998 \times 10^{-7} \text{ m}^2/\text{s})^2 = 8.310 \times 10^8. <$$

$$\text{Hence, } y_{bl} = 5 \times 0.15 \text{ m} \left( 8.310 \times 10^8 / 4 \right)^{-1/4} = 6.247 \times 10^{-3} \text{ m} = 6.3 \text{ mm}$$

and the minimum separation is

$$d = 2 y_{bl} = 2 \times 6.3 \text{ mm} = 12.6 \text{ mm}. <$$

**COMMENTS:** According to Eq. 9.23, the critical Grashof number for the onset of turbulent conditions in the boundary layer is  $\text{Gr}_{x,c} \text{Pr} \approx 10^9$ . For the conditions above,  $\text{Gr}_x \text{Pr} = 8.31 \times 10^8 \times 4.62 = 3.8 \times 10^9$ . We conclude that the boundary layer is indeed turbulent at  $x = 0.15\text{m}$  and our calculation is only an estimate which is likely to be low. Therefore, the plate separation should be greater than 12.6 mm.

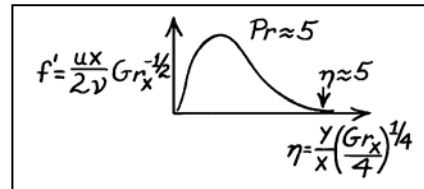

### PROBLEM 9.11

**KNOWN:** Vertical plate experiencing free convection with quiescent air at atmospheric pressure and film temperature 400 K.

**FIND:** Form of correlation for average heat transfer coefficient in terms of  $\Delta T$  and characteristic length.

**SCHEMATIC:**

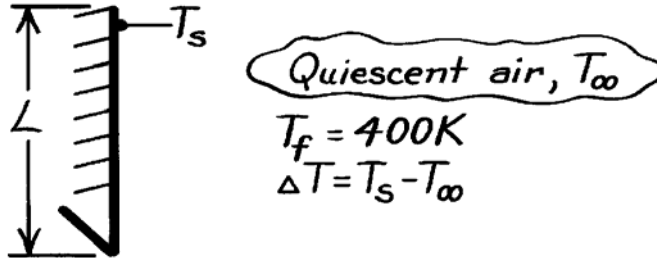

**ASSUMPTIONS:** (1) Air is extensive, quiescent medium, (2) Perfect gas behavior.

**PROPERTIES:** Table A-6, Air ( $T_f = 400K$ , 1 atm):  $\nu = 26.41 \times 10^{-6} \text{ m}^2/\text{s}$ ,  $k = 0.0338 \text{ W/m}\cdot\text{K}$ ,  $\alpha = 38.3 \times 10^{-6} \text{ m}^2/\text{s}$ .

**ANALYSIS:** Consider the correlation having the form of Eq. 9.24 with  $Ra_L$  defined by Eq. 9.25.

$$\overline{Nu}_L = \overline{h}_L L / k = C Ra_L^n \quad (1)$$

where

$$Ra_L = \frac{g\beta(T_s - T_{\infty})L^3}{\nu\alpha} = \frac{9.8 \text{ m/s}^2 (1/400 \text{ K})\Delta T \cdot L^3}{26.41 \times 10^{-6} \text{ m}^2/\text{s} \times 38.3 \times 10^{-6} \text{ m}^2/\text{s}} = 2.422 \times 10^7 \Delta T \cdot L^3. \quad (2)$$

Combining Eqs. (1) and (2),

$$\overline{h}_L = (k/L) C Ra_L^n = \frac{0.0338 \text{ W/m}\cdot\text{K}}{L} C \left( 2.422 \times 10^7 \Delta T L^3 \right)^n. \quad (3)$$

From Fig. 9.6, note that for laminar boundary layer conditions,  $10^4 < Ra_L < 10^9$ ,  $C = 0.59$  and  $n = 1/4$ . Using Eq. (3),

$$\overline{h} = 1.40 \left[ L^{-1} (\Delta T \cdot L^3)^{1/4} \right] = 1.40 \left( \frac{\Delta T}{L} \right)^{1/4} <$$

For turbulent conditions in the range  $10^9 < Ra_L < 10^{13}$ ,  $C = 0.10$  and  $n = 1/3$ . Using Eq. (3),

$$\overline{h}_L = 0.98 \left[ L^{-1} (\Delta T \cdot L^3)^{1/3} \right] = 0.98 \Delta T^{1/3}. <$$

**COMMENTS:** Note the dependence of the average heat transfer coefficient on  $\Delta T$  and  $L$  for laminar and turbulent conditions. The characteristic length  $L$  does not influence  $\overline{h}_L$  for turbulent conditions.



## PROBLEM 9.12

**KNOWN:** Temperature dependence of free convection coefficient,  $\bar{h} = C\Delta T^{1/4}$ , for a solid suddenly submerged in a quiescent fluid.

**FIND:** (a) Expression for cooling time,  $t_f$ , (b) Considering a plate of prescribed geometry and thermal conditions, the time required to reach  $80^\circ\text{C}$  using the appropriate correlation from Problem 9.11 and (c) Plot the temperature-time history obtained from part (b) and compare with results using a constant  $\bar{h}_0$  from an appropriate correlation based upon an average surface temperature  $\bar{T} = (T_i + T_f)/2$ .

**SCHEMATIC:**

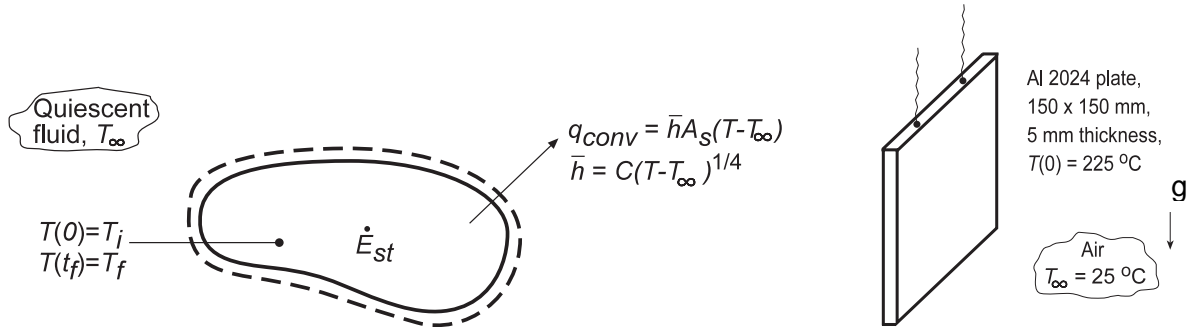

**ASSUMPTIONS:** (1) Lumped capacitance approximation is valid, (2) Negligible radiation, (3) Constant properties.

**PROPERTIES:** Table A.1, Aluminum alloy 2024 ( $\bar{T} = (T_i + T_f)/2 \approx 400\text{ K}$ ):  $\rho = 2770\text{ kg/m}^3$ ,  $c_p = 925\text{ J/kg}\cdot\text{K}$ ,  $k = 186\text{ W/m}\cdot\text{K}$ ; Table A.4, Air ( $\bar{T}_{\text{film}} = 362\text{ K}$ ):  $\nu = 2.221 \times 10^{-5}\text{ m}^2/\text{s}$ ,  $k = 0.03069\text{ W/m}\cdot\text{K}$ ,  $\alpha = 3.187 \times 10^{-5}\text{ m}^2/\text{s}$ ,  $\text{Pr} = 0.6976$ ,  $\beta = 1/\bar{T}_{\text{film}}$ .

**ANALYSIS:** (a) From Eq. 5.28,

$$\frac{\theta}{\theta_i} = \left[ \frac{n C A_s \theta_i^n}{\rho V c} t + 1 \right]^{-1/n} \quad (1)$$

where  $\theta = T - T_\infty$  and  $n = 1/4$ . Solving for  $t_f$ , the time at which  $T = T_f$ ,

$$t_f = \frac{4\rho V c}{C A_s (T_i - T_\infty)^{1/4}} \left[ \left( \frac{T_i - T_\infty}{T_f - T_\infty} \right)^{1/4} - 1 \right] \quad (2) <$$

(b) Considering the aluminum plate, initially at  $T(0) = 225^\circ\text{C}$ , and suddenly exposed to ambient air at  $T_\infty = 25^\circ\text{C}$ , from Problem 9.11 the convection coefficient has the form

$$\bar{h}_i = 1.40 \left( \frac{\Delta t}{L} \right)^{1/4} \quad \bar{h}_i = C \Delta T^{1/4}$$

where  $C = 1.40/L^{1/4} = 1.40/(0.150)^{1/4} = 2.2496\text{ W/m}^2 \cdot \text{K}^{3/4}$ . Using Eq. (2), find

Continued...

**PROBLEM 9.12 (Cont.)**

$$t_f = \frac{4 \times 2770 \text{ kg/m}^3 \left(0.150^2 \times 0.005\right) \text{m}^3 \times 925 \text{ J/kg} \cdot \text{K}}{2.2496 \text{ W/m}^2 \cdot \text{K}^{3/4} \times 2 \times (0.150 \text{ m})^2 (225 - 25)^{1/4} \text{ K}^{1/4}} \left[ \left( \frac{225 - 25}{80 - 25} \right)^{1/4} - 1 \right] = 1154 \text{ s}$$

(c) For the vertical plate, Eq. 9.27 is an appropriate correlation. Evaluating properties at

$$\bar{T}_{\text{film}} = (\bar{T}_s + T_\infty)/2 = ((T_i + T_f)/2 + T_\infty)/2 = 362 \text{ K}$$

where  $\bar{T}_s = 426 \text{ K}$ , the average plate temperature, find

$$\text{Ra}_L = \frac{g\beta(\bar{T}_s - T_\infty)L^3}{\nu\alpha} = \frac{9.8 \text{ m/s}^2 (1/362 \text{ K})(426 - 298) \text{ K} (0.150 \text{ m})^3}{2.221 \times 10^{-5} \text{ m}^2/\text{s} \times 3.187 \times 10^{-5} \text{ m}^2/\text{s}} = 1.652 \times 10^7$$

$$\bar{\text{Nu}}_L = 0.68 + \frac{0.670 \text{Ra}_L^{1/4}}{\left[1 + (0.492/\text{Pr})^{9/16}\right]^{4/9}} = 0.68 + \frac{0.670(1.652 \times 10^7)^{1/4}}{\left[1 + (0.492/0.6976)^{9/16}\right]^{4/9}} = 33.4$$

$$\bar{h}_o = \frac{k}{L} \bar{\text{Nu}}_L = \frac{0.03069 \text{ W/m} \cdot \text{K}}{0.150 \text{ m}} \times 33.4 = 6.83 \text{ W/m}^2 \cdot \text{K}$$

From Eq. 5.6, the temperature-time history with a constant convection coefficient is

$$T(t) = T_\infty + (T_i - T_\infty) \exp\left[-(\bar{h}_o A_s / \rho V c) t\right] \quad (3)$$

where  $A_s/V = 2L^2/(L \times L \times w) = 2/w = 400 \text{ m}^{-1}$ . The temperature-time histories for the  $h = \text{CaT}^{1/4}$  and  $\bar{h}_o$  analyses are shown in plot below.

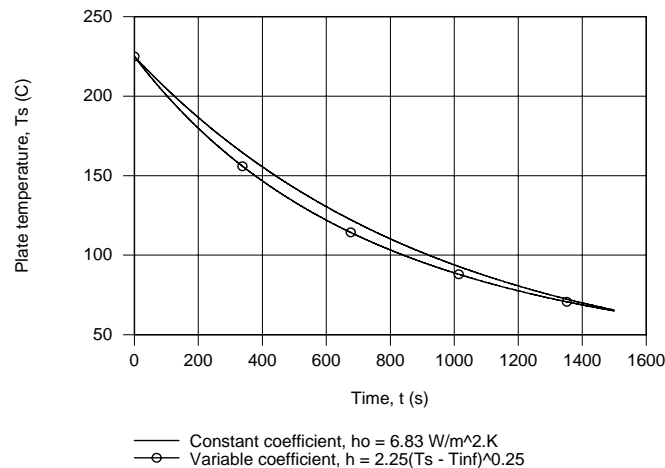

**COMMENTS:** (1) The times to reach  $T(t_o) = 80^\circ \text{C}$  were 1154 and 1212s for the variable and constant coefficient analysis, respectively, a difference of 5%. For convenience, it is reasonable to evaluate the convection coefficient as described in part (b).

(2) Note that  $\text{Ra}_L < 10^9$  so indeed the expression selected from Problem 9.11 was the appropriate one.

(3) Recognize that if the emissivity of the plate were unity, the average linearized radiation coefficient using Eq. (1.9) is  $\bar{h}_{\text{rad}} = 11.0 \text{ W/m}^2 \cdot \text{K}$  and radiative exchange becomes an important process.

### PROBLEM 9.13

**KNOWN:** Square aluminum plate at 15°C suspended in quiescent air at 40°C.

**FIND:** Average heat transfer coefficient by two methods – using results of boundary layer similarity and results from an empirical correlation.

**SCHEMATIC:**

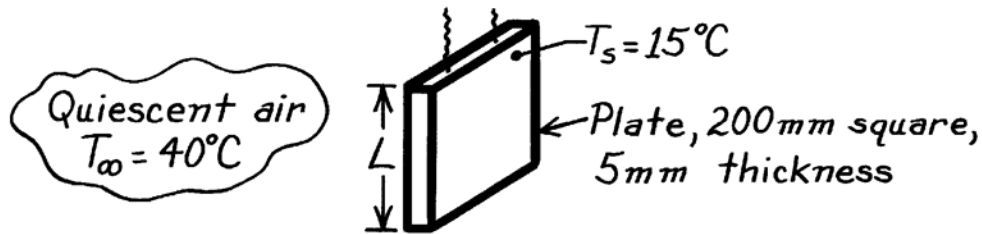

**ASSUMPTIONS:** (1) Uniform plate surface temperature, (2) Quiescent room air, (3) Surface radiation exchange with surroundings negligible, (4) Perfect gas behavior for air,  $\beta = 1/T_f$ .

**PROPERTIES:** Table A-4, Air ( $T_f = (T_s + T_\infty)/2 = (40 + 15)^\circ\text{C}/2 = 300\text{K}$ , 1 atm):  $\nu = 15.89 \times 10^{-6} \text{ m}^2/\text{s}$ ,  $k = 0.0263 \text{ W/m}\cdot\text{K}$ ,  $\alpha = 22.5 \times 10^{-6} \text{ m}^2/\text{s}$ ,  $\text{Pr} = 0.707$ .

**ANALYSIS:** Calculate the Rayleigh number to determine the boundary layer flow conditions,

$$\text{Ra}_L = g \beta \Delta T L^3 / \nu \alpha$$

$$\text{Ra}_L = 9.8 \text{ m/s}^2 (1/300\text{K}) (40 - 15)^\circ\text{C} (0.2\text{m})^3 / (15.89 \times 10^{-6} \text{ m}^2/\text{s}) (22.5 \times 10^{-6} \text{ m}^2/\text{s}) = 1.827 \times 10^7$$

where  $\beta = 1/T_f$  and  $\Delta T = T_\infty - T_s$ . Since  $\text{Ra}_L < 10^9$ , the flow is laminar and the *similarity solution* of Section 9.4 is applicable. From Eqs. 9.21 and 9.20,

$$\overline{\text{Nu}}_L = \frac{\overline{h}_L L}{k} = \frac{4}{3} (\text{Gr}_L / 4)^{1/4} g(\text{Pr}) \quad \text{where } g(\text{Pr}) = \frac{0.75 \text{Pr}^{1/2}}{[0.609 + 1.221 \text{Pr}^{1/2} + 1.238 \text{Pr}]^{1/4}}$$

and substituting numerical values with  $\text{Gr}_L = \text{Ra}_L / \text{Pr}$ , find

$$g(\text{Pr}) = 0.75 (0.707)^{1/2} / [0.609 + 1.22 (0.707)^{1/2} + 1.238 \times 0.707]^{1/4} = 0.501$$

$$\overline{h}_L = \left( \frac{0.0263 \text{ W/m}\cdot\text{K}}{0.20\text{m}} \right) \times \frac{4}{3} \left( \frac{1.827 \times 10^7 / 0.707}{4} \right)^{1/4} \times 0.501 = 4.42 \text{ W/m}^2 \cdot \text{K} <$$

The appropriate empirical correlation for estimating  $\overline{h}_L$  is given by Eq. 9.27,

$$\overline{\text{Nu}}_L = \frac{\overline{h}_L L}{k} = 0.68 + \frac{0.670 \text{Ra}_L^{1/4}}{[1 + (0.492 / \text{Pr})^{9/16}]^{4/9}}$$

$$\overline{h}_L = (0.0263 \text{ W/m}\cdot\text{K} / 0.20\text{m}) \left[ 0.68 + 0.670 (1.827 \times 10^7)^{1/4} / [1 + (0.492 / 0.707)^{9/16}]^{4/9} \right]$$

$$\overline{h}_L = 4.51 \text{ W/m}^2 \cdot \text{K} <$$

**COMMENTS:** The agreement of  $\overline{h}_L$  calculated by these two methods is excellent. Using the Churchill-Chu correlation, Eq. 9.26, find  $\overline{h}_L = 4.87 \text{ W/m}\cdot\text{K}$ . This relation is not the most accurate for the laminar regime, but is suitable for both laminar and turbulent regions.

### PROBLEM 9.14

**KNOWN:** Aluminum plate (alloy 2024) at an initial uniform temperature of 227°C is suspended in a room where the ambient air and surroundings are at 27°C.

**FIND:** (a) Expression for time rate of change of the plate, (b) Initial rate of cooling (K/s) when plate temperature is 227°C, (c) Validity of assuming a uniform plate temperature, (d) Decay of plate temperature and the convection and radiation rates during cooldown.

**SCHEMATIC:**

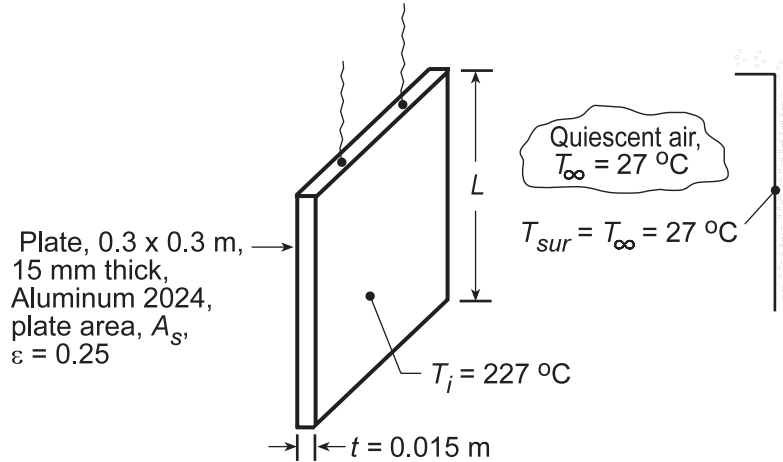

**ASSUMPTIONS:** (1) Plate temperature is uniform, (2) Ambient air is quiescent and extensive, (3) Surroundings are large compared to plate.

**PROPERTIES:** Table A.1, Aluminum alloy 2024 ( $T = 500\text{ K}$ ):  $\rho = 2770\text{ kg/m}^3$ ,  $k = 186\text{ W/m}\cdot\text{K}$ ,  $c = 983\text{ J/kg}\cdot\text{K}$ ; Table A.4, Air ( $T_f = 400\text{ K}$ , 1 atm):  $\nu = 26.41 \times 10^{-6}\text{ m}^2/\text{s}$ ,  $k = 0.0388\text{ W/m}\cdot\text{K}$ ,  $\alpha = 38.3 \times 10^{-6}\text{ m}^2/\text{s}$ ,  $\text{Pr} = 0.690$ .

**ANALYSIS:** (a) From an energy balance on the plate with free convection and radiation exchange,  $-\dot{E}_{\text{out}} = \dot{E}_{\text{st}}$ , we obtain

$$-\bar{h}_L 2A_s (T_s - T_\infty) - \varepsilon 2A_s \sigma (T_s^4 - T_{\text{sur}}^4) = \rho A_s t c \frac{dT}{dt} \quad \text{or} \quad \frac{dT}{dt} = \frac{-2}{\rho t c} \left[ \bar{h}_L (T_s - T_\infty) + \varepsilon \sigma (T_s^4 - T_{\text{sur}}^4) \right] <$$

where  $T_s$ , the plate temperature, is assumed to be uniform at any time.

(b) To evaluate  $(dT/dt)$ , estimate  $\bar{h}_L$ . First, find the Rayleigh number,

$$\text{Ra}_L = g\beta (T_s - T_\infty) L^3 / \nu\alpha = \frac{9.8\text{ m/s}^2 (1/400\text{ K})(227 - 27)\text{ K} \times (0.3\text{ m})^3}{26.41 \times 10^{-6}\text{ m}^2/\text{s} \times 38.3 \times 10^{-6}\text{ m}^2/\text{s}} = 1.308 \times 10^8.$$

Eq. 9.27 is appropriate; substituting numerical values, find

$$\overline{\text{Nu}}_L = 0.68 + \frac{0.670 \text{Ra}_L^{1/4}}{\left[1 + (0.492/\text{Pr})^{9/16}\right]^{4/9}} = 0.68 + \frac{0.670 (1.308 \times 10^8)^{1/4}}{\left[1 + (0.492/0.690)^{9/16}\right]^{4/9}} = 55.5$$

$$\bar{h}_L = \overline{\text{Nu}}_L k / L = 55.5 \times 0.0388\text{ W/m}\cdot\text{K} / 0.3\text{ m} = 6.25\text{ W/m}^2\cdot\text{K}$$

Continued...

**PROBLEM 9.14 (Cont.)**

$$\frac{dT}{dt} = \frac{-2}{2770 \text{ kg/m}^3 \times 0.015 \text{ m} \times 983 \text{ J/kg} \cdot \text{K}} \times \left[ 6.25 \text{ W/m}^2 \cdot \text{K} (227 - 27) \text{ K} + 0.25 \left( 5.67 \times 10^{-8} \text{ W/m}^2 \cdot \text{K}^4 \right) (500^4 - 300^4) \text{ K}^4 \right] = -0.099 \text{ K/s} \quad <$$

(c) The uniform temperature assumption is justified if the Biot number criterion is satisfied. With  $L_c \equiv (V/2A_s) = (A_s \cdot t/2A_s) = (t/2)$  and  $\bar{h}_{\text{tot}} = \bar{h}_{\text{conv}} + \bar{h}_{\text{rad}}$ ,  $\text{Bi} = \bar{h}_{\text{tot}} (t/2)/k \leq 0.1$ . Using the linearized radiation coefficient relation, find

$$\bar{h}_{\text{rad}} = \varepsilon \sigma (T_s + T_{\text{sur}}) (T_s^2 + T_{\text{sur}}^2) = 0.25 \left( 5.67 \times 10^{-8} \text{ W/m}^2 \cdot \text{K}^4 \right) (500 + 300) (500^2 + 300^2) \text{ K}^3 = 3.86 \text{ W/m}^2 \cdot \text{K}$$

Hence,  $\text{Bi} = (6.25 + 3.86) \text{ W/m}^2 \cdot \text{K} (0.015 \text{ m}/2) / 186 \text{ W/m} \cdot \text{K} = 4.07 \times 10^{-4}$ . Since  $\text{Bi} \ll 0.1$ , the assumption is appropriate.

(d) The temperature history of the plate was computed by combining the *Lumped Capacitance Model* of IHT with the appropriate *Correlations* and *Properties* Toolpads.

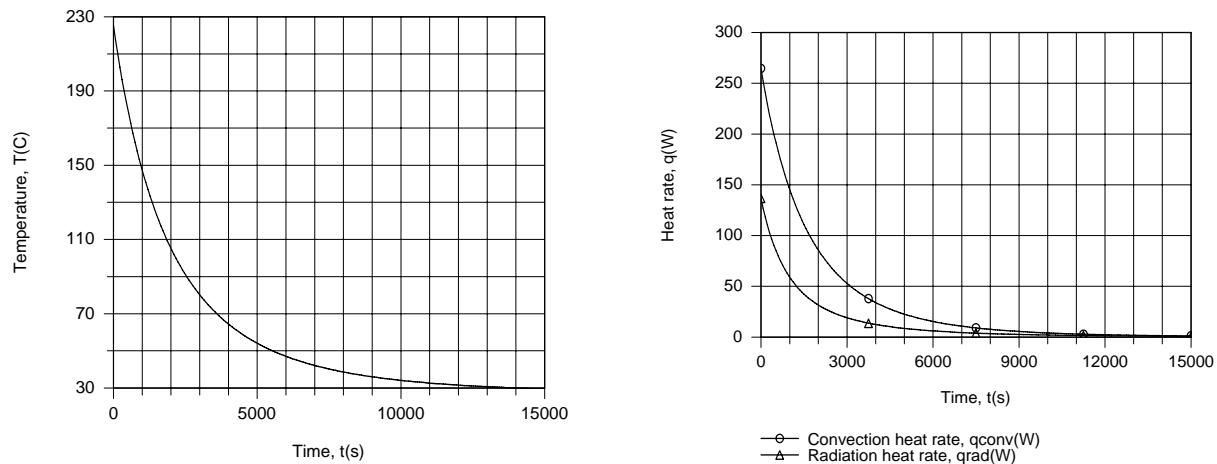

Due to the small values of  $\bar{h}_L$  and  $\bar{h}_{\text{rad}}$ , the plate cools slowly and does not reach 30°C until  $t \approx 14000\text{s} = 3.89\text{h}$ . The convection and radiation rates decrease rapidly with increasing  $t$  (decreasing  $T$ ), thereby decelerating the cooling process.

**COMMENTS:** The reduction in the convection rate with increasing time is due to a reduction in the thermal conductivity of air, as well as the values of  $\bar{h}_L$  and  $T$ .

## PROBLEM 9.15

**KNOWN:** Instantaneous temperature and time rate of temperature change of a vertical plate cooling in a room.

**FIND:** Average free convection coefficient for the prescribed conditions; compare with standard empirical correlation.

**SCHEMATIC:**

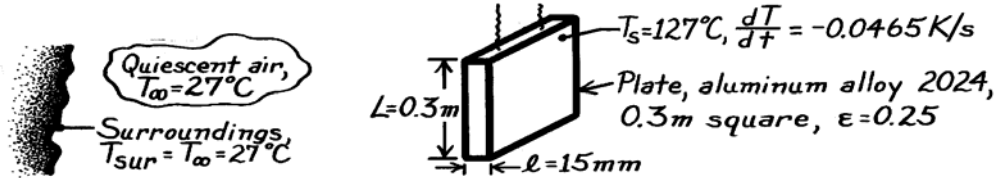

**ASSUMPTIONS:** (1) Uniform plate temperature, (2) Quiescent room air, (3) Large surroundings.

**PROPERTIES:** Table A-1, Aluminum alloy 2024 ( $T_s = 127^\circ\text{C} = 400\text{K}$ ):  $\rho = 2770\text{ kg/m}^3$ ,  $c_p = 925\text{ J/kg}\cdot\text{K}$ ; Table A-4, Air ( $T_f = (T_s + T_\infty)/2 = 350\text{K}$ , 1 atm):  $\nu = 20.92 \times 10^{-6}\text{ m}^2/\text{s}$ ,  $k = 0.030\text{ W/m}\cdot\text{K}$ ,  $\alpha = 29.9 \times 10^{-6}\text{ m}^2/\text{s}$ ,  $\text{Pr} = 0.700$ .

**ANALYSIS:** From an energy balance on the plate considering free convection and radiation exchange,

$$\dot{E}_{\text{in}} - \dot{E}_{\text{out}} = \dot{E}_{\text{st}}$$

$$-\bar{h}_L (2A_s)(T_s - T_\infty) - \varepsilon (2A_s)\sigma(T_s^4 - T_{\text{sur}}^4) = \rho A_s l c_p \frac{dT}{dt}.$$

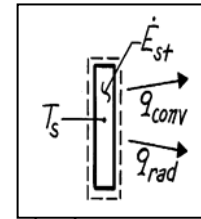

Noting that the plate area is  $2A_s$ , solving for  $\bar{h}_L$ , and substituting numerical values, find

$$\bar{h}_L = \left[ -\rho l c_p \frac{dT}{dt} - 2\varepsilon\sigma(T_s^4 - T_{\text{sur}}^4) \right] / 2(T_s - T_\infty)$$

$$\bar{h}_L = \left[ -2770\text{ kg/m}^3 \times 0.015\text{ m} \times 925\text{ J/kg}\cdot\text{K} (-0.0465\text{ K/s}) - 2 \times 0.25 \times 5.67 \times 10^{-8}\text{ W/m}^2 \cdot \text{K}^4 (400^4 - 300^4)\text{ K}^4 \right] / 2(127 - 27)^\circ\text{C} = (8.936 - 2.455)\text{ W/m}^2 \cdot \text{K}$$

$$\bar{h}_L = 6.5\text{ W/m}^2 \cdot \text{K}. \quad <$$

To select an appropriate empirical correlation, first evaluate the Rayleigh number,

$$\text{Ra}_L = g\beta\Delta TL^3 / \nu\alpha$$

$$\text{Ra}_L = 9.8\text{ m/s}^2 (1/350\text{K})(127 - 27)\text{K} (0.3\text{m})^3 / (20.92 \times 10^{-6}\text{ m}^2/\text{s})(29.9 \times 10^{-6}\text{ m}^2/\text{s}) = 1.21 \times 10^8.$$

Since  $\text{Ra}_L < 10^9$ , the flow is laminar and Eq. 9.27 is applicable,

$$\overline{\text{Nu}}_L = \frac{\bar{h}_L L}{k} = 0.68 + \frac{0.670 \text{Ra}_L^{1/4}}{\left[ 1 + (0.492/\text{Pr})^{9/16} \right]^{4/9}}$$

$$\bar{h}_L = \left( \frac{0.030\text{ W/m}\cdot\text{K}}{0.3\text{m}} \right) \left\{ 0.68 + 0.670 (1.21 \times 10^8)^{1/4} / \left[ 1 + (0.492/0.700)^{9/16} \right]^{4/9} \right\} = 5.5\text{ W/m}^2 \cdot \text{K}. \quad <$$

**COMMENTS:** (1) The correlation estimate is 15% lower than the experimental result. (2) This transient method, useful for obtaining an average free convection coefficient for spacewise isothermal objects, requires  $\text{Bi} \leq 0.1$ .

## PROBLEM 9.16

**KNOWN:** Interior air and wall temperatures; wall height.

**FIND:** (a) Average heat transfer coefficient when  $T_\infty = 20^\circ\text{C}$  and  $T_s = 10^\circ\text{C}$ , (b) Average heat transfer coefficient when  $T_\infty = 27^\circ\text{C}$  and  $T_s = 37^\circ\text{C}$ .

**SCHEMATIC:**

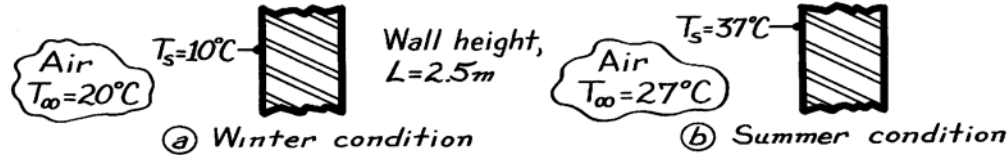

**ASSUMPTIONS:** (a) Wall is at a uniform temperature, (b) Room air is quiescent.

**PROPERTIES:** Table A-4, Air ( $T_f = 288\text{K}$ , 1 atm):  $\beta = 1/T_f = 3.472 \times 10^{-3} \text{ K}^{-1}$ ,  $\nu = 14.82 \times 10^{-6} \text{ m}^2/\text{s}$ ,  $k = 0.0253 \text{ W/m}\cdot\text{K}$ ,  $\alpha = 20.9 \times 10^{-6} \text{ m}^2/\text{s}$ ,  $\text{Pr} = 0.710$ ; ( $T_f = 305\text{K}$ , 1 atm):  $\beta = 1/T_f = 3.279 \times 10^{-3} \text{ K}^{-1}$ ,  $\nu = 16.39 \times 10^{-6} \text{ m}^2/\text{s}$ ,  $k = 0.0267 \text{ W/m}\cdot\text{K}$ ,  $\alpha = 23.2 \times 10^{-6} \text{ m}^2/\text{s}$ ,  $\text{Pr} = 0.706$ .

**ANALYSIS:** The appropriate correlation for the average heat transfer coefficient for free convection on a vertical wall is Eq. 9.26.

$$\overline{\text{Nu}}_L = \frac{\bar{h}L}{k} = \left\{ 0.825 + \frac{0.387 \text{Ra}_L^{0.1667}}{\left[ 1 + (0.492/\text{Pr})^{0.563} \right]^{0.296}} \right\}^2$$

where  $\text{Ra}_L = g \beta \Delta T L^3 / \nu \alpha$ , Eq. 9.25, with  $\Delta T = T_s - T_\infty$  or  $T_\infty - T_s$ .

(a) Substituting numerical values typical of *winter* conditions gives

$$\text{Ra}_L = \frac{9.8 \text{ m/s}^2 \times 3.472 \times 10^{-3} \text{ K}^{-1} (20 - 10) \text{ K} (2.5 \text{ m})^3}{14.82 \times 10^{-6} \text{ m}^2/\text{s} \times 20.96 \times 10^{-6} \text{ m}^2/\text{s}} = 1.711 \times 10^{10}$$

$$\overline{\text{Nu}}_L = \left\{ 0.825 + \frac{0.387 (1.711 \times 10^{10})^{0.1667}}{\left[ 1 + (0.492/0.710)^{0.563} \right]^{0.296}} \right\}^2 = 299.6.$$

Hence,  $\bar{h} = \overline{\text{Nu}}_L k/L = 299.6(0.0253 \text{ W/m}\cdot\text{K})/2.5 \text{ m} = 3.03 \text{ W/m}^2 \cdot \text{K}$ . <

(b) Substituting numerical values typical of *summer* conditions gives

$$\text{Ra}_L = \frac{9.8 \text{ m/s}^2 \times 3.279 \times 10^{-3} \text{ K}^{-1} (37 - 27) \text{ K} (2.5 \text{ m})^3}{23.2 \times 10^{-6} \text{ m}^2/\text{s} \times 16.39 \times 10^{-6} \text{ m}^2/\text{s}} = 1.320 \times 10^{10}$$

$$\overline{\text{Nu}}_L = \left\{ 0.825 + \frac{0.387 (1.320 \times 10^{10})^{0.1667}}{\left[ 1 + (0.492/0.706)^{0.563} \right]^{0.296}} \right\}^2 = 275.8.$$

Hence,  $\bar{h} = \overline{\text{Nu}}_L k/L = 275.8 \times 0.0267 \text{ W/m}\cdot\text{K}/2.5 \text{ m} = 2.94 \text{ W/m}^2 \cdot \text{K}$ . <

**COMMENTS:** There is a small influence due to  $T_f$  on  $\bar{h}$  for these conditions. We should expect radiation effects to be important with such low values of  $\bar{h}$ .

### PROBLEM 9.17

**KNOWN:** Dimensions of vertical plate. Plate and ambient temperatures.

**FIND:** Preferred orientation to minimize convective heat transfer and convective heat transfer rate for that orientation.

**SCHEMATIC:**

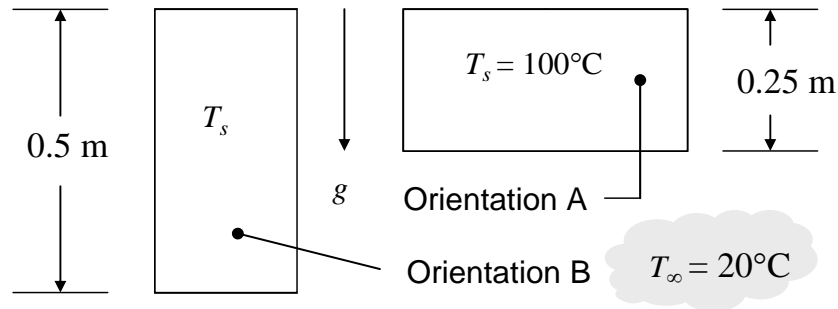

**ASSUMPTIONS:** (1) Steady-state conditions, (2) Constant properties, (3) Ideal gas, (4) Quiescent environment.

**PROPERTIES:** Table A.4, air ( $\bar{T} = 60^\circ\text{C} = 333\text{ K}$ ):  $\nu = 19.21 \times 10^{-6}\text{ m}^2/\text{s}$ ,  $\alpha = 27.4 \times 10^{-6}\text{ m}^2/\text{s}$ ,  $Pr = 0.702$ ,  $k = 0.0287\text{ W/m}\cdot\text{K}$ .

**ANALYSIS:** Note that the maximum value of the Rayleigh number is associated with Orientation B.

$$Ra_{\max} = \frac{g\beta(T_s - T_\infty)L^3}{\nu \cdot \alpha} = \frac{9.81\text{ m/s}^2 \times (1/333\text{ K}) \times (100 - 20)^\circ\text{C} \times (0.5\text{ m})^3}{19.21 \times 10^{-6}\text{ m}^2/\text{s} \times 27.4 \times 10^{-6}\text{ m}^2/\text{s}} = 560 \times 10^6$$

Since the maximum Rayleigh number is less than  $Ra_{x,c} = 10^9$ , flow conditions are laminar for both orientations. Hence, to minimize heat transfer from the plate, we wish to maximize the thickness of the boundary layer and therefore maximize the plate length in the vertical direction. Therefore, Orientation B is preferred. <

Selecting Eq. 9.27,

$$\begin{aligned} \bar{h} &= \frac{k}{L} \left\{ 0.68 + \frac{0.67 Ra_L^{1/4}}{\left[ 1 + (0.492/Pr)^{9/16} \right]^{4/9}} \right\} \\ &= \frac{0.0287\text{ W}/(\text{m}\cdot\text{K})}{0.5\text{ m}} \left\{ 0.68 + \frac{0.67 \times (560 \times 10^6)^{1/4}}{\left[ 1 + (0.492/0.702)^{9/16} \right]^{4/9}} \right\} = 4.57 \frac{\text{W}}{\text{m}^2 \cdot \text{K}} \end{aligned}$$

and

$$q = \bar{h}A(T_s - T_\infty) = 4.57\text{ W}/\text{m}^2 \cdot \text{K} \times (0.25\text{ m} \times 0.50\text{ m}) \times (100 - 20)^\circ\text{C} = 45.7\text{ W} \quad <$$

**COMMENTS:** 1. For Orientation A,  $Ra = 7 \times 10^7$ ,  $\bar{h} = 5.48\text{ W}/\text{m}^2 \cdot \text{K}$  and  $q = 54.8\text{ W}$ . Although the Rayleigh and Nusselt numbers are smaller for Orientation A, the length scale in the Nusselt number is half that of Orientation B, leading to an overall increase in the convection coefficient and heat transfer rate. 2. Radiation heat transfer will be significant.



## PROBLEM 9.18

**KNOWN:** During a winter day, the window of a patio door with a height of 1.8 m and width of 1.0 m shows a frost line near its base.

**FIND:** (a) Explain why the window would show a frost layer at the base of the window, rather than at the top, and (b) Estimate the heat loss through the window due to free convection and radiation. If the room has electric baseboard heating, estimate the daily cost of the window heat loss for this condition based upon the utility rate of 0.18 \$/kW·h.

**SCHEMATIC:**

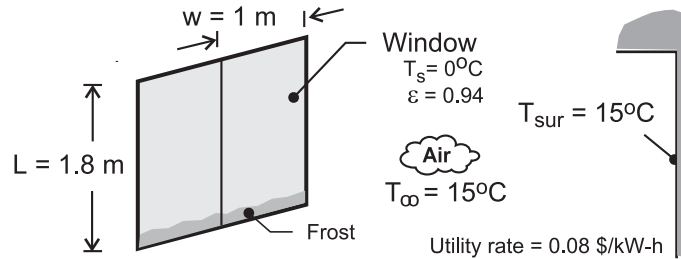

**ASSUMPTIONS:** (1) Steady-state conditions, (2) Window has a uniform temperature, (3) Ambient air is quiescent, and (4) Room walls are isothermal and large compared to the window.

**PROPERTIES:** Table A-4, Air ( $T_f = (T_s + T_\infty)/2 = 280 \text{ K}$ , 1 atm):  $\nu = 14.11 \times 10^{-6} \text{ m}^2/\text{s}$ ,  $k = 0.0247 \text{ W/m}\cdot\text{K}$ ,  $\alpha = 1.986 \times 10^{-5} \text{ m}^2/\text{s}$ ,  $\text{Pr} = 0.710$ .

**ANALYSIS:** (a) For these winter conditions, a frost line could appear and it would be at the bottom of the window. The boundary layer is thinnest at the top of the window, and hence the heat flux from the warmer room is greater than compared to that at the bottom portion of the window where the boundary layer is thicker. Also, the air in the room may be stratified and cooler near the floor compared to near the ceiling.

(b) The heat loss from the room to the window having a uniform temperature  $T_s = 0^\circ\text{C}$  by convection and radiation is

$$q_{\text{loss}} = q_{\text{cv}} + q_{\text{rad}} \quad (1)$$

$$q_{\text{loss}} = A_s \left[ \bar{h}_L (T_\infty - T_s) + \varepsilon \sigma (T_{\text{sur}}^4 - T_s^4) \right] \quad (2)$$

The average convection coefficient is estimated from the Churchill-Chu correlation, Eq. 9.26, using properties evaluated at  $T_f = (T_s + T_\infty)/2$ .

$$\overline{\text{Nu}}_L = \frac{\bar{h}_L L}{k} = \left\{ 0.825 + \frac{0.387 \text{ Ra}_L^{1/6}}{\left[ 1 + (0.492/\text{Pr})^{9/16} \right]^{8/27}} \right\}^2 \quad (3)$$

$$\text{Ra}_L = g\beta T (T_\infty - T_s) L^3 / \nu\alpha \quad (4)$$

Substituting numerical values in the correlation expressions, find

$$\text{Ra}_L = 1.084 \times 10^{10} \quad \overline{\text{Nu}}_L = 258.9 \quad \bar{h}_L = 3.6 \text{ W/m}^2 \cdot \text{K}$$

Continued ...

### PROBLEM 9.18 (Cont.)

Using Eq. (2), the heat loss with  $\sigma = 5.67 \times 10^{-8} \text{ W/m}^2 \cdot \text{K}^4$  is

$$q_{\text{loss}} = (1 \times 1.8) \text{ m}^2 \left[ 3.6 \text{ W/m}^2 \cdot \text{K} (15 \text{ K}) + 0.940 \sigma (288^4 - 273^4) \text{ K}^4 \right]$$

$$q_{\text{loss}} = (96.1 + 127.1) \text{ W} = 223 \text{ W}$$

The daily cost of the window heat loss for the given utility rate is

$$\text{cost} = q_{\text{loss}} \times (\text{utility rate}) \times 24 \text{ hours}$$

$$\text{cost} = 223 \text{ W} \times (10^{-3} \text{ kW/W}) \times 0.18 \text{ \$/kW} \cdot \text{h} \times 24 \text{ h}$$

$$\text{cost} = 0.96 \text{ \$/day}$$

<

**COMMENTS:** Note that the heat loss by radiation is 30% larger than by free convection.

### PROBLEM 9.19

**KNOWN:** Room and ambient air conditions for window glass.

**FIND:** Temperature of the glass and rate of heat loss.

**SCHEMATIC:**

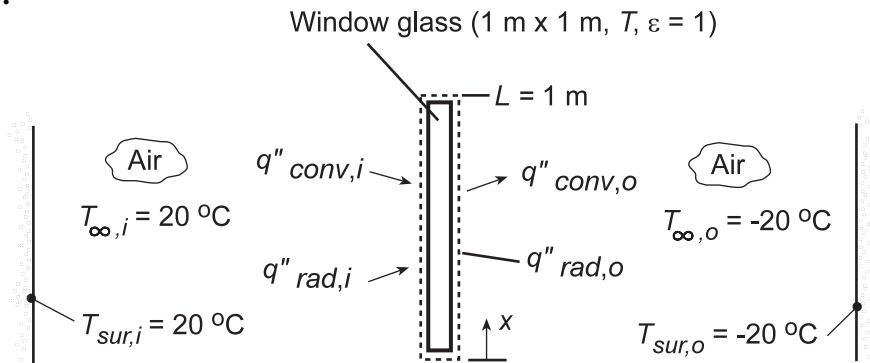

**ASSUMPTIONS:** (1) Steady-state conditions, (2) Negligible temperature gradients in the glass, (3) Inner and outer surfaces exposed to large surroundings.

**PROPERTIES:** Table A.4, air ( $T_{f,i}$  and  $T_{f,o}$ ): Obtained from the IHT *Properties* Tool Pad.

**ANALYSIS:** Performing an energy balance on the window pane, it follows that  $\dot{E}_{in} = \dot{E}_{out}$ , or

$$\varepsilon\sigma(T_{sur,i}^4 - T^4) + \bar{h}_i(T_{\infty,i} - T) = \varepsilon\sigma(T^4 - T_{sur,o}^4) + \bar{h}_o(T - T_{\infty,o})$$

where  $\bar{h}_i$  and  $\bar{h}_o$  may be evaluated from Eq. 9.26.

$$\bar{Nu}_L = \left\{ 0.825 + \frac{0.387Ra_L^{1/6}}{\left[1 + (0.492/Pr)^{9/16}\right]^{8/27}} \right\}^2$$

Using the *First Law Model for an Isothermal Plane Wall* and the *Correlations and Properties* Tool Pads of IHT, the energy balance equation was formulated and solved to obtain

$$T = 273.8 \text{ K} \quad <$$

The heat rate is then  $q_i = q_o$ , or

$$q_i = L^2 \left[ \varepsilon\sigma(T_{sur,i}^4 - T^4) + \bar{h}_i(T_{\infty,i} - T) \right] = 174.8 \text{ W} \quad <$$

**COMMENTS:** The radiative and convective contributions to heat transfer at the inner and outer surfaces are  $q_{rad,i} = 99.04 \text{ W}$ ,  $q_{conv,i} = 75.73 \text{ W}$ ,  $q_{rad,o} = 86.54 \text{ W}$ , and  $q_{conv,o} = 88.23 \text{ W}$ , with corresponding convection coefficients of  $\bar{h}_i = 3.95 \text{ W/m}^2\cdot\text{K}$  and  $\bar{h}_o = 4.23 \text{ W/m}^2\cdot\text{K}$ . The heat loss could be reduced significantly by installing a double pane window.

## PROBLEM 9.20

**KNOWN:** Room and ambient air conditions for window glass. Thickness and thermal conductivity of glass.

**FIND:** Inner and outer surface temperatures and heat loss.

**SCHEMATIC:**

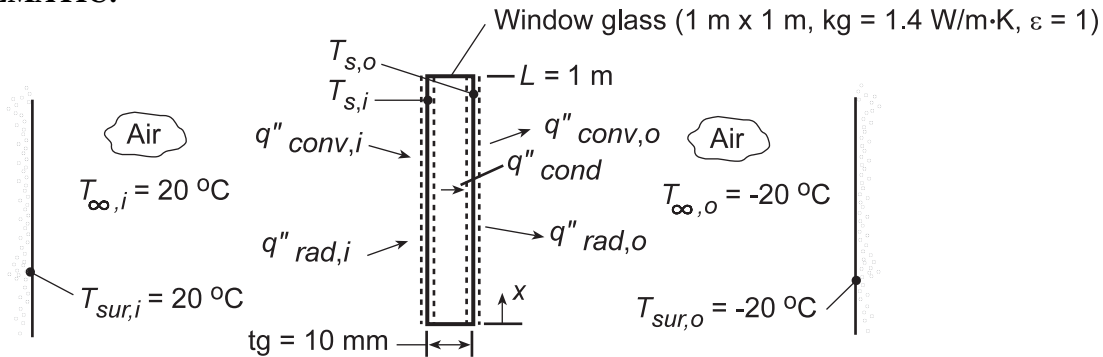

**ASSUMPTIONS:** (1) Steady-state conditions, (2) One-dimensional conduction in the glass, (3) Inner and outer surfaces exposed to large surroundings.

**PROPERTIES:** Table A.4, air ( $T_{f,i}$  and  $T_{f,o}$ ): Obtained from the IHT *Properties* Tool Pad.

**ANALYSIS:** Performing energy balances at the inner and outer surfaces, we obtain, respectively,

$$\varepsilon\sigma(T_{sur,i}^4 - T_{s,i}^4) + \bar{h}_i(T_{\infty,i} - T_{s,i}) = (k_g/t_g)(T_{s,i} - T_{s,o}) \quad (1)$$

$$(k_g/t_g)(T_{s,i} - T_{s,o}) = \varepsilon\sigma(T_{s,o}^4 - T_{sur,o}^4) + \bar{h}_o(T_{s,o} - T_{\infty,o}) \quad (2)$$

where Eq. 9.26 may be used to evaluate  $\bar{h}_i$  and  $\bar{h}_o$

$$\bar{Nu}_L = \left\{ 0.825 + \frac{0.387Ra_L^{1/6}}{\left[1 + (0.492/Pr)^{9/16}\right]^{8/27}} \right\}^2$$

Using the *First Law Model for One-dimensional Conduction in a Plane Wall* and the *Correlations and Properties* Tool Pads of IHT, the energy balance equations were formulated and solved to obtain

$$T_{s,i} = 274.4 \text{ K} \quad T_{s,o} = 273.2 \text{ K} \quad <$$

from which the heat loss is

$$q = \frac{k_g L^2}{t_g} (T_{s,i} - T_{s,o}) = 168.8 \text{ W} \quad <$$

**COMMENTS:** By accounting for the thermal resistance of the glass, the heat loss is smaller (168.8 W) than that determined in the preceding problem (174.8 W) by assuming an isothermal pane.

## PROBLEM 9.21

**KNOWN:** Oven door with average surface temperature of 32°C in a room with ambient air at 22°C.

**FIND:** Heat loss to the room. Also, find effect on heat loss if emissivity of door is unity and the surroundings are at 22°C.

**SCHEMATIC:**

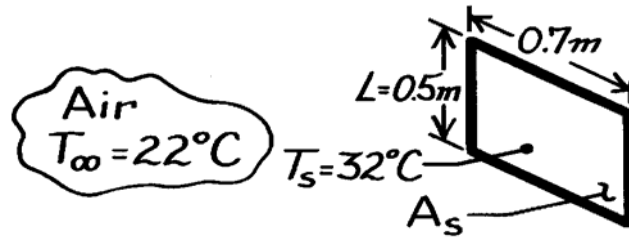

**ASSUMPTIONS:** (1) Ambient air is quiescent, (2) Surface radiation effects are negligible.

**PROPERTIES:** Table A-4, Air ( $T_f = 300\text{K}$ , 1 atm):  $\nu = 15.89 \times 10^{-6} \text{ m}^2/\text{s}$ ,  $k = 0.0263 \text{ W/m}\cdot\text{K}$ ,  $\alpha = 22.5 \times 10^{-6} \text{ m}^2/\text{s}$ ,  $\text{Pr} = 0.707$ ,  $\beta = 1/T_f = 3.33 \times 10^{-3} \text{ K}^{-1}$ .

**ANALYSIS:** The heat rate from the oven door surface by convection to the ambient air is

$$q = \bar{h} A_s (T_s - T_\infty) \quad (1)$$

where  $\bar{h}$  can be estimated from the free-convection correlation for a vertical plate, Eq. 9.26,

$$\overline{\text{Nu}}_L = \frac{\bar{h}L}{k} = \left\{ 0.825 + \frac{0.387 \text{Ra}_L^{1/6}}{\left[ 1 + (0.492/\text{Pr})^{9/16} \right]^{8/27}} \right\}^2 \quad (2)$$

The Rayleigh number, Eq. 9.25, is

$$\text{Ra}_L = \frac{g\beta(T_s - T_\infty)L^3}{\nu\alpha} = \frac{9.8 \text{ m/s}^2 (1/300\text{K})(32 - 22)\text{K} \times 0.5^3 \text{ m}^3}{15.89 \times 10^{-6} \text{ m}^2/\text{s} \times 22.5 \times 10^{-6} \text{ m}^2/\text{s}} = 1.142 \times 10^8.$$

Substituting numerical values into Eq. (2), find

$$\overline{\text{Nu}}_L = \left\{ 0.825 + \frac{0.387 (1.142 \times 10^8)^{1/6}}{\left[ 1 + (0.492/0.707)^{9/16} \right]^{8/27}} \right\}^2 = 63.5$$

$$\bar{h}_L = \frac{k}{L} \overline{\text{Nu}}_L = \frac{0.0263 \text{ W/m}\cdot\text{K}}{0.5 \text{ m}} \times 63.5 = 3.34 \text{ W/m}^2 \cdot \text{K}.$$

The heat rate using Eq. (1) is

$$q = 3.34 \text{ W/m}^2 \cdot \text{K} \times (0.5 \times 0.7) \text{ m}^2 (32 - 22) \text{ K} = 11.7 \text{ W}. \quad <$$

Heat loss by radiation, assuming  $\varepsilon = 1$ , is

$$q_{\text{rad}} = \varepsilon A_s \sigma (T_s^4 - T_{\text{sur}}^4)$$

$$q_{\text{rad}} = 1(0.5 \times 0.7) \text{ m}^2 \times 5.67 \times 10^{-8} \text{ W/m}^2 \cdot \text{K}^4 \left[ (273 + 32)^4 - (273 + 22)^4 \right] \text{ K}^4 = 21.4 \text{ W}. \quad <$$

Note that heat loss by radiation is nearly double that by free convection. Using Eq. (1.9), the radiation heat transfer coefficient is  $h_{\text{rad}} = 6.4 \text{ W/m}^2 \cdot \text{K}$ , which is twice the coefficient for the free convection process.

## PROBLEM 9.22

**KNOWN:** Dimensions of window pane with frost formation on inner surface. Temperature of room air and walls.

**FIND:** Heat loss through window.

**SCHEMATIC:**

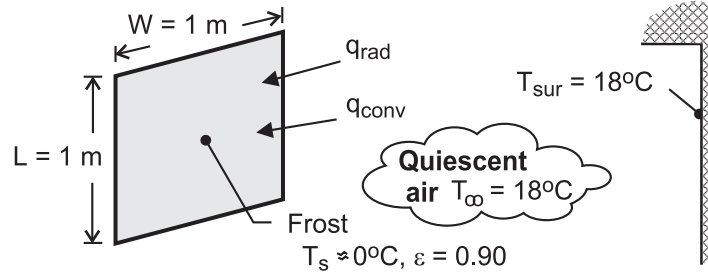

**ASSUMPTIONS:** (1) Steady-state, (2) Surface of frost is isothermal with  $T_s \approx 0^\circ\text{C}$ , (3) Radiation exchange is between a small surface (window) and a large enclosure (walls of room), (4) Room air is quiescent.

**PROPERTIES:** Table A-4, air ( $T_f = 9^\circ\text{C} = 282\text{ K}$ ):  $k = 0.0249\text{ W/m}\cdot\text{K}$ ,  $\nu = 14.3 \times 10^{-6}\text{ m}^2/\text{s}$ ,  $\alpha = 20.1 \times 10^{-6}\text{ m}^2/\text{s}$ ,  $\text{Pr} = 0.712$ ,  $\beta = 3.55 \times 10^{-3}\text{ K}^{-1}$ .

**ANALYSIS:** Under steady-state conditions, the heat loss through the window corresponds to the rate of heat transfer to the frost by convection and radiation.

$$q = q_{\text{conv}} + q_{\text{rad}} = W \times L \left[ \bar{h} (T_\infty - T_s) + \varepsilon \sigma (T_{\text{sur}}^4 - T_s^4) \right]$$

$$\text{With } \text{Ra}_L = g\beta(T_\infty - T_s)L^3 / \alpha\nu = 9.8\text{ m/s}^2 \times 0.00355\text{ K}^{-1} \times 18\text{ K} (1\text{ m})^3 / (14.3 \times 20.1 \times 10^{-12}\text{ m}^4/\text{s}^2) \\ = 2.18 \times 10^9, \text{ Eq. (9.26) yields}$$

$$\bar{\text{Nu}}_L = \left\{ 0.825 + \frac{0.387 \text{Ra}_L^{1/6}}{\left[ 1 + (0.492/\text{Pr})^{9/16} \right]^{8/27}} \right\}^2 = 156.5$$

$$\bar{h} = \text{Nu}_L \frac{k}{L} = 156.5 \left( \frac{0.0249\text{ W/m}\cdot\text{K}}{1\text{ m}} \right) = 3.9\text{ W/m}^2 \cdot \text{K}$$

$$q = 1\text{ m}^2 \left[ 3.9\text{ W/m}^2 \cdot \text{K} (18\text{ K}) + 0.90 \times 5.67 \times 10^{-8}\text{ W/m}^2 \cdot \text{K}^4 (291^4 - 273^4) \right]$$

$$= 70.2\text{ W} + 82.5\text{ W} = 152.7\text{ W} \quad <$$

**COMMENTS:** (1) The thickness of the frost layer does not affect the heat loss, since the inner surface of the layer remains at  $T_s \approx 0^\circ\text{C}$ . However, the temperature of the glass/frost interface decreases with increasing thickness, from a value of  $0^\circ\text{C}$  for negligible thickness. (2) Since the thermal boundary layer thickness is zero at the top of the window and has its maximum value at the bottom, the temperature of the glass will actually be largest and smallest at the top and bottom, respectively. Hence, frost will first begin to form at the bottom.

## PROBLEM 9.23

**KNOWN:** Length of isothermal vertical plate,  $L$ .

**FIND:** Expression for the ratio of the average heat transfer coefficients for  $N$  plates each of length  $L_N = L/N$  to the average coefficient for the single plate.

**SCHEMATIC:**

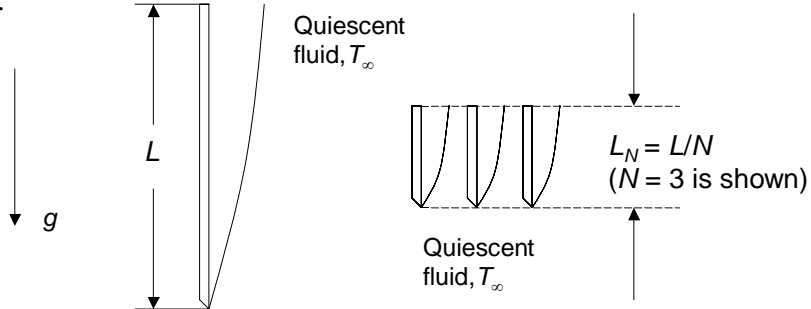

**ASSUMPTIONS:** (1) Constant properties.

**ANALYSIS:** Equation 9.21 yields, for the single plate,

$$\overline{Nu}_L = \frac{\bar{h}L}{k} = \frac{4}{3} \left( \frac{Gr_L}{4} \right)^{1/4} g(Pr) \quad \text{or} \quad \bar{h}_{L,1} = \frac{4k}{3L} \left( \frac{Gr_L}{4} \right)^{1/4} g(Pr) \quad (1)$$

For multiple plates,

$$\overline{Nu}_{L,N} = \frac{\bar{h}_{L,N}L_N}{k} = \frac{4}{3} \left( \frac{Gr_{L,N}}{4} \right)^{1/4} g(Pr) \quad \text{where} \quad L_N = L/N \quad \text{and} \quad Gr_{L,N} = Gr_L/(N^3) \quad (2a, b, c)$$

Combining Equations 2a, 2b and 2c yields

$$\bar{h}_{L,N} = \frac{4Nk}{3L} \left( \frac{Gr_L}{4N^3} \right)^{1/4} g(Pr) \quad (3)$$

Dividing Equation 3 by Equation 1 yields

$$\bar{h}_{L,N} / \bar{h}_{L,1} = N \left( \frac{1}{N^3} \right)^{1/4} = N^{1/4} <$$

**COMMENTS:** (1) By breaking the single plate into shorter segments, the average boundary layer thickness is reduced, resulting in a modest increase in the average heat transfer coefficient and, in turn, the convective heat transfer from the plate. (2) The relationship for laminar *forced* convection for an isothermal plate in parallel flow is  $\bar{h}_{L,N} / \bar{h}_{L,1} = N^{1/2}$ , illustrating that, in general, enhancement of free convection heat transfer is more challenging than enhancement of forced convection. See Problem 7.11.

## PROBLEM 9.24

**KNOWN:** Plate dimensions, initial temperature, and final temperature. Air temperature.

**FIND:** (a) Initial cooling rate, (b) Time to reach prescribed final temperature.

**SCHEMATIC:**

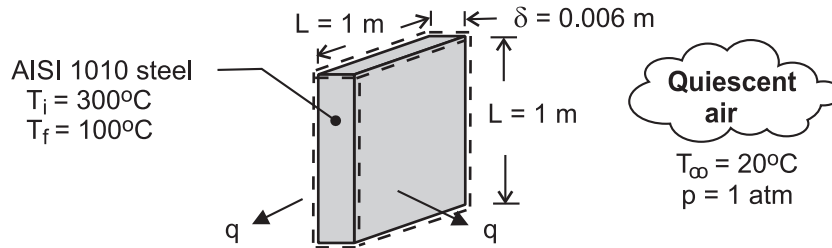

**ASSUMPTIONS:** (1) Plate is spacewise isothermal as it cools (lumped capacitance approximation), (2) Negligible heat transfer from minor sides of plate, (3) Thermal boundary layer development corresponds to that for an isolated plate (negligible interference between adjoining boundary layers). (4) Negligible radiation. (5) Constant properties.

**PROPERTIES:** Table A-1, AISI 1010 steel ( $\bar{T} = 473 \text{ K}$ ):  $\rho = 7832 \text{ kg/m}^3$ ,  $c = 513 \text{ J/kg}\cdot\text{K}$ . Table A-4, air ( $T_{f,i} = 433 \text{ K}$ ):  $\nu = 30.4 \times 10^{-6} \text{ m}^2/\text{s}$ ,  $k = 0.0361 \text{ W/m}\cdot\text{K}$ ,  $\alpha = 44.2 \times 10^{-6} \text{ m}^2/\text{s}$ ,  $\text{Pr} = 0.687$ ,  $\beta = 0.0023 \text{ K}^{-1}$ .

**ANALYSIS:** (a) The initial rate of heat transfer is  $q_i = \bar{h} A_s (T_i - T_\infty)$ , where  $A_s \approx 2L^2 = 2 \text{ m}^2$ .

With  $\text{Ra}_{L,i} = g\beta(T_i - T_\infty)L^3/\alpha\nu = 9.8 \text{ m/s}^2 \times 0.0021 (280)1\text{m}^3/44.2 \times 10^{-6} \text{ m}^2/\text{s} \times 30.4 \times 10^{-6} \text{ m}^2/\text{s} = 4.72 \times 10^9$ , Eq. 9.26 yields

$$\bar{h} = \frac{0.0361 \text{ W/m}\cdot\text{K}}{1\text{m}} \left\{ 0.825 + \frac{0.387 \left( 4.72 \times 10^9 \right)^{1/6}}{\left[ 1 + \left( 0.492 / 0.687 \right)^{9/16} \right]^{8/27}} \right\}^2 = 7.16 \text{ W/m}^2 \cdot \text{K}$$

Hence,  $q_i = 7.16 \text{ W/m}^2 \cdot \text{K} \times 2\text{m}^2 \times 280^\circ\text{C} = 4010 \text{ W}$  <

(b) From an energy balance at an instant of time for a control surface about the plate,  $-q = \dot{E}_{st} = \rho L^2 \delta c dT/dt$ , the rate of change of the plate temperature is

$$\frac{dT}{dt} = -\frac{\bar{h} 2L^2 (T - T_\infty)}{\rho L^2 \delta c} = -\frac{2\bar{h}}{\rho \delta c} (T - T_\infty)$$

where the Rayleigh number, and hence  $\bar{h}$ , changes with time due to the change in the temperature of the plate. Integrating the foregoing equation with the DER function of IHT, the following results are obtained for the temperature history of the plate.

Continued ...



### PROBLEM 9.24 (Cont.)

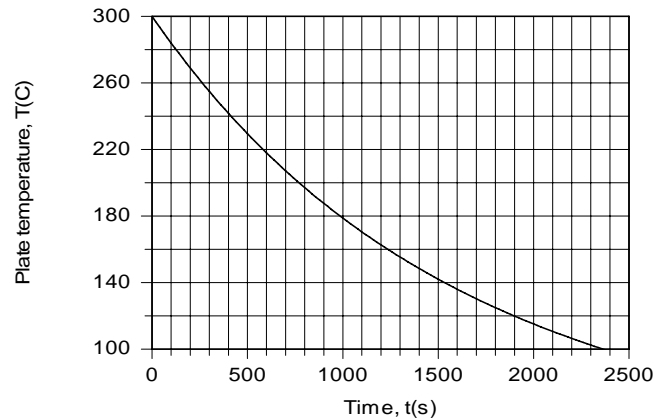

The time for the plate to cool to 100°C is

$$t \approx 2365 \text{ s}$$

<

**COMMENTS:** (1) Although the plate temperature is comparatively large and radiation emission is significant relative to convection, much of the radiation leaving one plate is intercepted by the adjoining plate if the spacing between plates is small relative to their width. The net effect of radiation on the plate temperature would then be small. (2) Because of the increase in  $\beta$  and reductions in  $\nu$  and  $\alpha$  with increasing  $t$ , the Rayleigh number decreases only slightly as the plate cools from 300°C to 100°C (from  $4.72 \times 10^9$  to  $4.48 \times 10^9$ ), despite the significant reduction in  $(T - T_\infty)$ . The reduction in  $\bar{h}$  from 7.2 to 5.6  $\text{W/m}^2 \cdot \text{K}$  is principally due to a reduction in the thermal conductivity.

## PROBLEM 9.25

**KNOWN:** Thin-walled container with hot process fluid at 50°C placed in a quiescent, cold water bath at 10°C.

**FIND:** (a) Overall heat transfer coefficient,  $U$ , between the hot and cold fluids, and (b) Compute and plot  $U$  as a function of the hot process fluid temperature for the range  $20 \leq T_{\infty,h} \leq 50^\circ\text{C}$ .

**SCHEMATIC:**

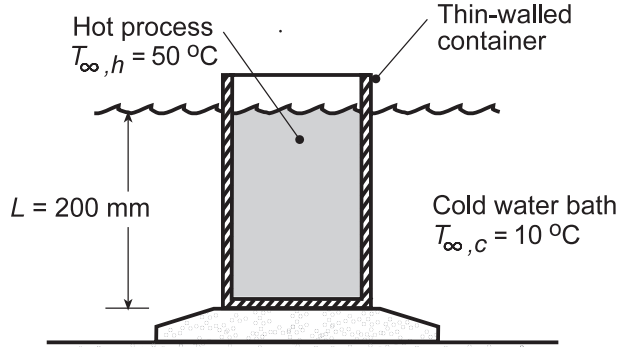

**ASSUMPTIONS:** (1) Steady-state conditions, (2) Heat transfer at the surfaces approximated by free convection from a vertical plate, (3) Fluids are extensive and quiescent, (4) Hot process fluid thermophysical properties approximated as those of water, and (5) Negligible container wall thermal resistance.

**PROPERTIES:** *Table A.6*, Water (assume  $T_{f,h} = 310 \text{ K}$ ):  $\rho_h = 1/1.007 \times 10^{-3} = 993 \text{ kg/m}^3$ ,  $c_{p,h} = 4178 \text{ J/kg}\cdot\text{K}$ ,  $\nu_h = \mu_h/\rho_h = 695 \times 10^{-6} \text{ N}\cdot\text{s/m}^2/993 \text{ kg/m}^3 = 6.999 \times 10^{-7} \text{ m}^2/\text{s}$ ,  $k_h = 0.628 \text{ W/m}\cdot\text{K}$ ,  $\text{Pr}_h = 4.62$ ,  $\alpha_h = k_h/\rho_h c_{p,h} = 1.514 \times 10^{-7} \text{ m}^2/\text{s}$ ,  $\beta_h = 361.9 \times 10^{-6} \text{ K}^{-1}$ ; *Table A.6*, Water (assume  $T_{f,c} = 295 \text{ K}$ ):  $\rho_c = 1/1.002 \times 10^{-3} = 998 \text{ kg/m}^3$ ,  $c_{p,c} = 4181 \text{ J/kg}\cdot\text{K}$ ,  $\nu_c = \mu_c/\rho_c = 959 \times 10^{-6} \text{ N}\cdot\text{s/m}^2/998 \text{ kg/m}^3 = 9.609 \times 10^{-7} \text{ m}^2/\text{s}$ ,  $k_c = 0.606 \text{ W/m}\cdot\text{K}$ ,  $\text{Pr}_c = 6.62$ ,  $\alpha_c = k_c/\rho_c c_{p,c} = 1.452 \times 10^{-7} \text{ m}^2/\text{s}$ ,  $\beta_c = 227.5 \times 10^{-6} \text{ K}^{-1}$ .

**ANALYSIS:** (a) The overall heat transfer coefficient between the hot process fluid,  $T_{\infty,h}$ , and the cold water bath fluid,  $T_{\infty,c}$ , is

$$U = \left( \frac{1}{\bar{h}_h} + \frac{1}{\bar{h}_c} \right)^{-1} \quad (1)$$

where the average free convection coefficients can be estimated from the vertical plate correlation Eq. 9.26, with the Rayleigh number, Eq. 9.25,

$$\bar{Nu}_L = \left\{ 0.825 + \frac{0.387 \text{Ra}_L^{1/6}}{\left[ 1 + (0.492/\text{Pr})^{9/16} \right]^{8/27}} \right\}^2 \quad \text{Ra}_L = \frac{g\beta\Delta T L^3}{\nu\alpha} \quad (2,3)$$

To affect a solution, assume  $T_s = (T_{\infty,h} + T_{\infty,c})/2 = 30^\circ\text{C} = 303 \text{ K}$ , so that the hot and cold fluid film temperatures are  $T_{f,h} = 313 \text{ K} \approx 310 \text{ K}$  and  $T_{f,c} = 293 \text{ K} \approx 295 \text{ K}$ . From an energy balance across the container walls,

$$\bar{h}_h (T_{\infty,h} - T_s) = \bar{h}_c (T_s - T_{\infty,c}) \quad (4)$$

the surface temperature  $T_s$  can be determined. Evaluating the correlation parameters, find:

*Hot process fluid:*

$$\text{Ra}_{L,h} = \frac{9.8 \text{ m/s}^2 \times 361.9 \times 10^{-6} \text{ K}^{-1} (50 - 30) \text{ K} (0.200 \text{ m})^3}{6.999 \times 10^{-7} \text{ m}^2/\text{s} \times 1.514 \times 10^{-7} \text{ m}^2/\text{s}} = 5.357 \times 10^9$$

Continued...

**PROBLEM 9.25 (Cont.)**

$$\overline{Nu}_{L,h} = \left\{ 0.825 + \frac{0.387 \left( 5.357 \times 10^9 \right)^{1/6}}{\left[ 1 + \left( 0.492/4.62 \right)^{9/16} \right]^{8/27}} \right\}^2 = 251.5$$

$$\overline{h}_h = \overline{Nu}_{L,h} \frac{h_h}{L} = 251.5 \times 0.628 \text{ W/m}^2 \cdot \text{K} / 0.200 \text{ m} = 790 \text{ W/m}^2 \cdot \text{K}$$

Cold water bath:

$$Ra_{L,c} = \frac{9.8 \text{ m/s}^2 \times 227.5 \times 10^{-6} \text{ K}^{-1} (30 - 10) \text{ K} (0.200 \text{ m})^3}{9.609 \times 10^{-7} \text{ m}^2/\text{s} \times 1.452 \times 10^{-7} \text{ m}^2/\text{s}} = 2.557 \times 10^9$$

$$\overline{Nu}_{L,c} = \left\{ 0.825 + \frac{0.387 \left( 2.557 \times 10^9 \right)^{1/6}}{\left[ 1 + \left( 0.492/6.62 \right)^{9/16} \right]^{8/27}} \right\}^2 = 203.9$$

$$\overline{h}_c = 203.9 \times 0.606 \text{ W/m}^2 \cdot \text{K} / 0.200 \text{ m} = 618 \text{ W/m}^2 \cdot \text{K}$$

From Eq. (1) find

$$U = (1/790 + 1/618)^{-1} \text{ W/m}^2 \cdot \text{K} = 347 \text{ W/m}^2 \cdot \text{K}$$

Using Eq.(4), find the resulting surface temperature

$$790 \text{ W/m}^2 \cdot \text{K} (50 - T_s) \text{ K} = 618 \text{ W/m}^2 \cdot \text{K} (T_s - 10) \text{ K} \quad T_s = 32.4^\circ \text{C}$$

Which compares favorably with our assumed value of 30°C.

(b) Using the *IHT Correlations Tool, Free Convection, Vertical Plate* and following the foregoing approach, the overall coefficient was computed as a function of the hot fluid temperature and is plotted below. Note that  $U$  increases almost linearly with  $T_{\infty,h}$ .

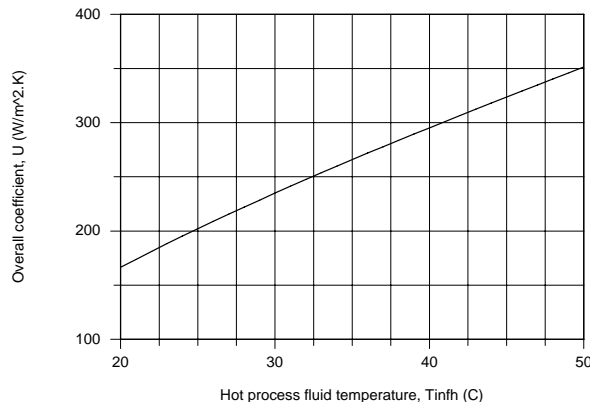

**COMMENTS:** For the conditions of part (a), using the IHT model of part (b) with thermophysical properties evaluated at the proper film temperatures, find  $U = 352 \text{ W/m}^2 \cdot \text{K}$  with  $T_s = 32.4^\circ \text{C}$ . Our approximate solution was a good one.

(2) Because the set of equations for part (b) is quite stiff, when using the IHT model you should follow the suggestions in the IHT Example 9.2 including use of the intrinsic function Tfluid\_avg (T1,T2).

## PROBLEM 9.26

**KNOWN:** Size and emissivity of a vertical heated plate. Temperature of the ambient and surroundings.

**FIND:** (a) Electrical power to be supplied to the plate in order to achieve a plate temperature of  $T_s = 35^\circ\text{C}$  for  $\varepsilon = 0.95$ . Fraction of the plate exposed to turbulent conditions, (b) Steady-state plate temperature for  $\varepsilon = 0.05$  and fraction of the plate exposed to turbulent conditions.

**SCHEMATIC:**

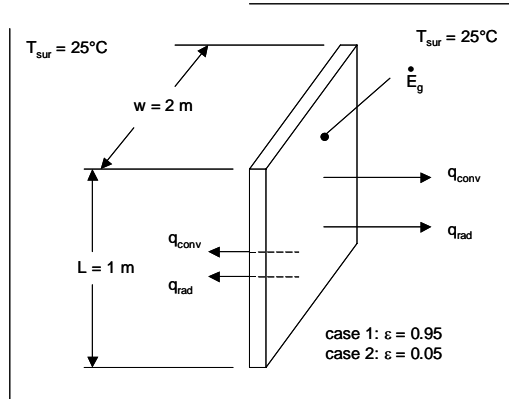

**ASSUMPTIONS:** (1) Constant properties and steady-state conditions, (2) Large surroundings, (3) Isothermal plate, (4) Critical Rayleigh number of  $\text{Ra}_{x,c} = 10^9$ .

**PROPERTIES:** Table A.4, air: ( $T_f = 303\text{ K}$ ):  $k = 0.02652\text{ W/m}\cdot\text{K}$ ,  $\nu = 1.619 \times 10^{-5}\text{ m}^2/\text{s}$ ,  $\alpha = 2.294 \times 10^{-5}\text{ m}^2/\text{s}$ ,  $\text{Pr} = 0.7066$ .

**ANALYSIS:** (a) The Rayleigh number is

$$\text{Ra}_L = \frac{g\beta\Delta T L^3}{\nu\alpha} = \frac{9.8\text{ m/s}^2 \times (1/303\text{ K}) \times 10^\circ\text{C} \times (1\text{ m})^3}{1.619 \times 10^{-5}\text{ m}^2/\text{s} \times 2.294 \times 10^{-5}\text{ m}^2/\text{s}} = 8.71 \times 10^8 \quad (1)$$

Since  $\text{Ra} < \text{Ra}_{x,c}$ , the boundary layer is completely laminar. The electric power required is

$$P = \dot{E}_g = q_{\text{conv}} + q_{\text{rad}} = \bar{h}A(T_s - T_\infty) + \varepsilon A\sigma(T_s^4 - T_{\text{sur}}^4) \quad (2)$$

The convection coefficient may be found from the Churchill and Chu correlation

$$\bar{\text{Nu}}_L = \left\{ 0.825 + \frac{0.387 \times (8.71 \times 10^8)^{1/6}}{\left[ 1 + (0.492/0.7066)^{9/16} \right]^{8/27}} \right\}^2 = 117.6 \quad (3)$$

Thus, the convection coefficient is

Continued...

**PROBLEM 9.26 (Cont.)**

$$\bar{h} = \overline{\text{Nu}}_L k / L = 117.6 \times 0.02652 \text{ W/m} \cdot \text{K} / 1\text{m} = 3.12 \text{ W/m}^2 \cdot \text{K}$$

Hence, Equation 2 is written

$$\begin{aligned} P &= 2 \times (1\text{m} \times 2\text{m}) \times 3.12 \text{ W/m}^2 \cdot \text{K} \times (35 - 25)^\circ\text{C} \\ &\quad + 0.95 \times 5.67 \times 10^{-8} \text{ W/m}^2 \cdot \text{K}^4 \times (308^4 - 298^4) \text{K}^4 < \\ &= 124.8 \text{ W} + 239.8 \text{ W} = 364.2 \text{ W} \end{aligned}$$

(b) Equations 1, 2 and 3 may be solved simultaneously with the constraint that  $P = 364.6 \text{ W}$ . Property variations may be taken into account by using IHT. A simultaneous solution of Equations 1 through 3 yields

$$\text{Ra}_L = 1.71 \times 10^9, \overline{\text{Nu}}_L = 144.9, \bar{h} = 3.906 \text{ W/m}^2 \cdot \text{K}, T_s = 319.5 \text{ K} = 46.5^\circ\text{C} <$$

The length of the plate that is subjected to laminar conditions may be found from the definition of the Rayleigh number,  $\text{Ra}_L = g\beta\Delta T L^3 / \nu\alpha$  and the knowledge that  $T_f = (319.5 \text{ K} + 298 \text{ K})/2 = 308.8 \text{ K}$ .

$$L = \left( \frac{\text{Ra}_{x,c} \nu \alpha}{g\beta\Delta T} \right)^{1/3} = \left( \frac{10^9 \times 1.677 \times 10^{-5} \text{ m}^2/\text{s} \times 2.379 \times 10^{-5} \text{ m}^2/\text{s}}{9.8 \text{ m/s} \times (1/308.8 \text{ K}) \times (319.5 \text{ K} - 298 \text{ K})} \right)^{1/3} = 0.836 \text{ m} <$$

Therefore,  $1\text{m} - 0.836\text{m} = 0.164\text{m}$  or 16.4% of the plate is exposed to turbulent conditions.

**COMMENTS:** (1) In part (b), the convection and radiation heat rates are 335.9 W and 28.74 W, respectively. Convection dominates in part (b) while in part (a) radiation losses are significantly larger than convection losses. (2) Radiation exchange can fundamentally alter the nature of the flow in free convection systems. (3) The polished plate would slowly oxidize over time, causing *drift* in the experimentalist's measurements of the transition to turbulent flow. (4) The properties used in part (b) are evaluated at the film temperature of  $T_f = 308.8 \text{ K}$  and are  $k = 0.02695 \text{ W/m}\cdot\text{K}$ ,  $\nu = 1.677 \times 10^{-5} \text{ m}^2/\text{s}$ ,  $\alpha = 2.397 \times 10^{-5} \text{ m}^2/\text{s}$ ,  $\text{Pr} = 0.7058$ .

## PROBLEM 9.27

**KNOWN:** Boundary conditions associated with a rear window experiencing uniform volumetric heating.

**FIND:** (a) Volumetric heating rate  $\dot{q}$  needed to maintain inner surface temperature at  $T_{s,i} = 15^\circ\text{C}$ , (b) Effects of  $T_{\infty,o}$ ,  $u_\infty$ , and  $T_{\infty,i}$  on  $\dot{q}$  and  $T_{s,o}$ .

**SCHEMATIC:**

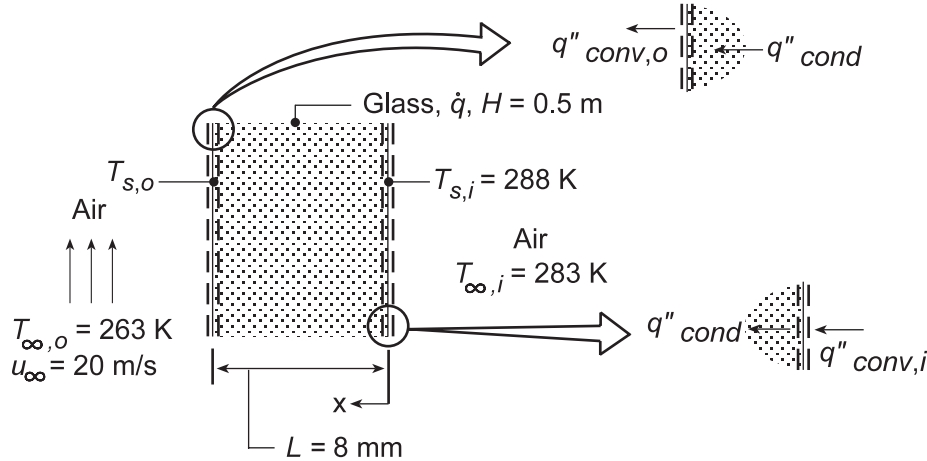

**ASSUMPTIONS:** (1) Steady-state, one-dimensional conditions, (2) Constant properties, (3) Uniform volumetric heating in window, (4) Convection heat transfer from interior surface of window to interior air may be approximated as free convection from a vertical plate, (5) Heat transfer from outer surface is due to forced convection over a flat plate in parallel flow.

**PROPERTIES:** Table A.3, Glass (300 K):  $k = 1.4 \text{ W/m}\cdot\text{K}$ ; Table A.4, Air ( $T_{f,i} = 12.5^\circ\text{C}$ , 1 atm):  $\nu = 14.6 \times 10^{-6} \text{ m}^2/\text{s}$ ,  $k = 0.0251 \text{ W/m}\cdot\text{K}$ ,  $\alpha = 20.59 \times 10^{-6} \text{ m}^2/\text{s}$ ,  $\beta = (1/285.5) = 3.503 \times 10^{-3} \text{ K}^{-1}$ ,  $\text{Pr} = 0.711$ ; ( $T_{f,o} \approx 0^\circ\text{C}$ ):  $\nu = 13.49 \times 10^{-6} \text{ m}^2/\text{s}$ ,  $k = 0.0241 \text{ W/m}\cdot\text{K}$ ,  $\text{Pr} = 0.714$ .

**ANALYSIS:** (a) The temperature distribution in the glass is governed by the appropriate form of the heat equation, Eq. 3.44, whose general solution is given by Eq. 3.45.

$$T(x) = -(\dot{q}/2k)x^2 + C_1x + C_2.$$

The constants of integration may be evaluated by applying appropriate boundary conditions at  $x = 0$ . In particular, with  $T(0) = T_{s,i}$ ,  $C_2 = T_{s,i}$ . Applying an energy balance to the inner surface,  $q''_{\text{cond}} = q''_{\text{conv},i}$

$$-k \left. \frac{dT}{dx} \right|_{x=0} = \bar{h}_i (T_{\infty,i} - T_{s,i}) \quad -k \left( -\frac{\dot{q}}{k}x + C_1 \right) \Big|_{x=0} = \bar{h}_i (T_{\infty,i} - T_{s,i})$$

$$C_1 = -(\bar{h}_i/k)(T_{\infty,i} - T_{s,i})$$

$$T(x) = -(\dot{q}/2k)x^2 - \frac{\bar{h}_i (T_{\infty,i} - T_{s,i})}{k}x + T_{s,i} \quad (1)$$

The required generation may then be obtained by formulating an energy balance at the outer surface, where  $q''_{\text{cond}} = q''_{\text{conv},o}$ . Using Eq. (1),

$$-k \left. \frac{dT}{dx} \right|_{x=L} = \bar{h}_o (T_{s,o} - T_{\infty,o}) \quad (2)$$

Continued...

**PROBLEM 9.27 (Cont.)**

$$-k \left. \frac{dT}{dx} \right|_{x=L} = -k \left( -\frac{\dot{q}L}{k} \right) + \bar{h}_i (T_{\infty,i} - T_{s,i}) = \dot{q}L + \bar{h}_i (T_{\infty,i} - T_{s,i}) \quad (3)$$

Substituting Eq. (3) into Eq. (2), the energy balance becomes

$$\dot{q}L = \bar{h}_o (T_{s,o} - T_{\infty,o}) + \bar{h}_i (T_{s,i} - T_{\infty,i}) \quad (4)$$

where  $T_{s,o}$  may be evaluated by applying Eq. (1) at  $x = L$ .

$$T_{s,o} = -\frac{\dot{q}L^2}{2k} - \frac{\bar{h}_i (T_{\infty,i} - T_{s,i})}{k} L + T_{s,i}. \quad (5)$$

The *inside* convection coefficient may be obtained from Eq. 9.26. With

$$Ra_H = \frac{g\beta (T_{s,i} - T_{\infty,i}) H^3}{\nu\alpha} = \frac{9.8 \text{ m/s}^2 (3.503 \times 10^{-3} \text{ K}^{-1}) (15 - 10) \text{ K} (0.5 \text{ m})^3}{14.60 \times 10^{-6} \text{ m}^2/\text{s} \times 20.59 \times 10^{-6} \text{ m}^2/\text{s}} = 7.137 \times 10^7,$$

$$\bar{Nu}_H = \left[ 0.825 + \frac{0.387 Ra_H^{1/6}}{\left[ 1 + (0.492/Pr)^{9/16} \right]^{8/27}} \right]^2 = \left[ 0.825 + \frac{0.387 (7.137 \times 10^7)^{1/6}}{\left[ 1 + (0.492/0.711)^{9/16} \right]^{8/27}} \right]^2 = 55.2$$

$$\bar{h}_i = \bar{Nu}_H \frac{k}{H} = \frac{55.2 \times 0.0251 \text{ W/m} \cdot \text{K}}{0.5 \text{ m}} = 2.77 \text{ W/m}^2 \cdot \text{K}$$

The *outside* convection coefficient may be obtained by first evaluating the Reynolds number. With

$$Re_H = \frac{u_{\infty} H}{\nu} = \frac{20 \text{ m/s} \times 0.5 \text{ m}}{13.49 \times 10^{-6} \text{ m}^2/\text{s}} = 7.413 \times 10^5$$

and with  $Re_{x,c} = 5 \times 10^5$ , mixed boundary layer conditions exist. Hence,

$$\bar{Nu}_H = (0.037 Re_H^{4/5} - 871) Pr^{1/3} = \left[ 0.037 (7.413 \times 10^5)^{4/5} - 871 \right] (0.714)^{1/3} = 864$$

$$\bar{h}_o = \bar{Nu}_H (k/H) = (864 \times 0.0241 \text{ W/m} \cdot \text{K}) / 0.5 \text{ m} = 41.6 \text{ W/m}^2 \cdot \text{K}.$$

Eq. (5) may now be expressed as

$$T_{s,o} = -\frac{\dot{q}(0.008 \text{ m})^2}{2(1.4 \text{ W/m} \cdot \text{K})} - \frac{2.77 \text{ W/m}^2 \cdot \text{K} (10 - 15) \text{ K}}{1.4 \text{ W/m} \cdot \text{K}} \times 0.008 \text{ m} + 288 \text{ K} = -2.286 \times 10^{-5} \dot{q} + 288.1 \text{ K}$$

$$\text{or, solving for } \dot{q}, \quad \dot{q} = -43,745 (T_{s,o} - 288.1) \quad (6)$$

and substituting into Eq. (4),

$$-43,745 (T_{s,o} - 288.1) (0.008 \text{ m}) = 41.6 \text{ W/m}^2 \cdot \text{K} (T_{s,o} - 263 \text{ K}) + 2.77 \text{ W/m}^2 \cdot \text{K} (288 \text{ K} - 283 \text{ K}).$$

It follows that  $T_{s,o} = 285.4 \text{ K}$  in which case, from Eq. (6)

$$\dot{q} = 118 \text{ kW/m}^3. \quad \leftarrow$$

(b) The parametric calculations were performed using the *One-Dimensional, Steady-state Conduction* Model of IHT with the appropriate *Correlations* and *Properties* Tool Pads, and the results are as follows.

Continued...

### PROBLEM 9.27 (Cont.)

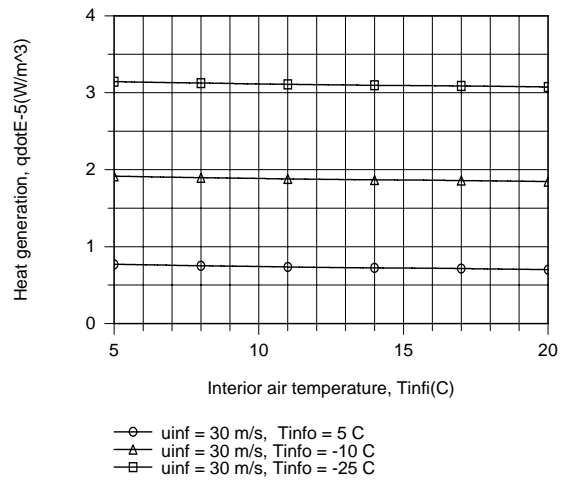
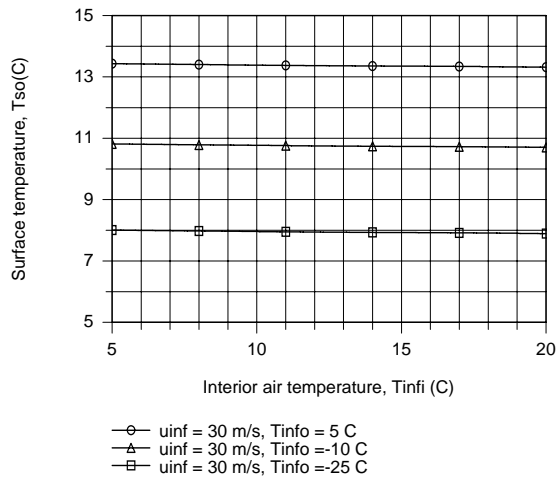
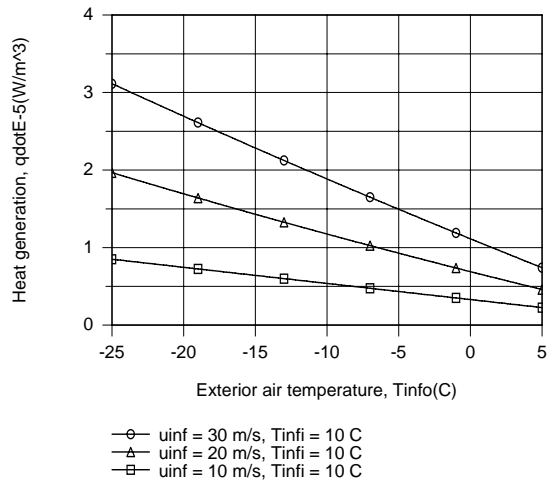
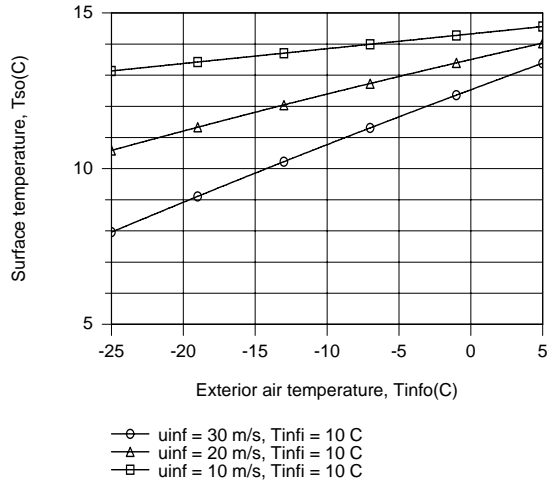

For fixed  $T_{s,i}$  and  $T_{\infty,i}$ ,  $T_{s,o}$  and  $\dot{q}$  are strongly influenced by  $T_{\infty,o}$  and  $u_{\infty}$ , increasing and decreasing, respectively, with increasing  $T_{\infty,o}$  and decreasing and increasing, respectively with increasing  $u_{\infty}$ . For fixed  $T_{s,i}$  and  $u_{\infty}$ ,  $T_{s,o}$  and  $\dot{q}$  are independent of  $T_{\infty,i}$ , but increase and decrease, respectively, with increasing  $T_{\infty,o}$ .

**COMMENTS:** In lieu of performing a surface energy balance at  $x = L$ , Eq. (4) may also be obtained by applying an energy balance to a control volume about the entire window.



### PROBLEM 9.28

**KNOWN:** Vertical panel with uniform heat flux exposed to ambient air.

**FIND:** Allowable heat flux if maximum temperature is not to exceed a specified value,  $T_{max}$ .

**SCHEMATIC:**

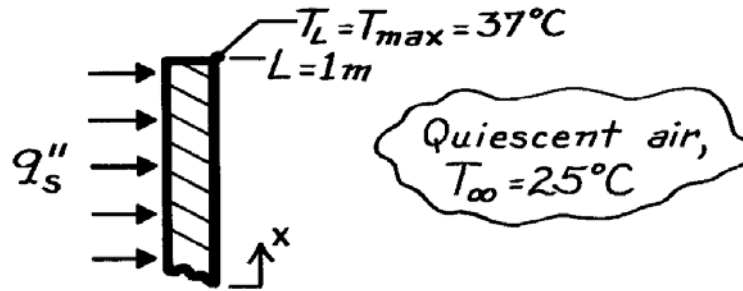

**ASSUMPTIONS:** (1) Constant properties, (2) Radiative exchange with surroundings negligible.

**PROPERTIES:** Table A-4, Air ( $T_f = (T_{L/2} + T_\infty)/2 = (35.4 + 25)^\circ\text{C}/2 = 30.2^\circ\text{C} = 303\text{K}$ , 1 atm):  $\nu = 16.19 \times 10^{-6} \text{ m}^2/\text{s}$ ,  $k = 26.5 \times 10^{-3} \text{ W/m}\cdot\text{K}$ ,  $\alpha = 22.9 \times 10^{-6} \text{ m}^2/\text{s}$ ,  $\text{Pr} = 0.707$ .

**ANALYSIS:** Following the treatment of Section 9.6.1 for a vertical plate with uniform heat flux (constant  $q_s''$ ), the heat flux can be evaluated as

$$q_s'' = \bar{h} \Delta T_{L/2} \quad \text{where} \quad \Delta T_{L/2} = T_s(L/2) - T_\infty \quad (1,2)$$

and  $\bar{h}$  is evaluated using an appropriate correlation for a constant temperature vertical plate. From Eq. 9.28,

$$\Delta T_x \equiv T_x - T_\infty = 1.15(x/L)^{1/5} \Delta T_{L/2} \quad (3)$$

and recognizing that the maximum temperature will occur at the top edge,  $x = L$ , use Eq. (3) to find

$$\Delta T_{L/2} = (37 - 25)^\circ\text{C} / 1.15(1/1)^{1/5} = 10.4^\circ\text{C} \quad \text{or} \quad T_{L/2} = 35.4^\circ\text{C}.$$

Calculate now the Rayleigh number based upon  $\Delta T_{L/2}$ , with  $T_f = (T_{L/2} + T_\infty)/2 = 303\text{K}$ ,

$$\text{Ra}_L = \frac{g\beta\Delta T L^3}{\nu\alpha} \quad \text{where} \quad \Delta T = \Delta T_{L/2} \quad (4)$$

$$\text{Ra}_L = 9.8 \text{ m/s}^2 (1/303\text{K}) \times 10.4\text{K} (1\text{m})^3 / 16.19 \times 10^{-6} \text{ m}^2/\text{s} \times 22.9 \times 10^{-6} \text{ m}^2/\text{s} = 9.07 \times 10^8.$$

Since  $\text{Ra}_L < 10^9$ , the boundary layer flow is laminar; hence the correlation of Eq. 9.27 is appropriate,

$$\overline{\text{Nu}}_L = \frac{\bar{h}L}{k} = 0.68 + \frac{0.670 \text{ Ra}_L^{1/4}}{\left[1 + (0.492/\text{Pr})^{9/16}\right]^{4/9}} \quad (5)$$

$$\bar{h} = \left[ \frac{0.0265 \text{ W/m}\cdot\text{K}}{1\text{m}} \right] \left\{ 0.68 + \frac{0.670 (9.07 \times 10^8)^{1/4}}{\left[1 + (0.492/0.707)^{9/16}\right]^{4/9}} \right\} = 2.38 \text{ W/m}^2 \cdot \text{K}.$$

From Eqs. (1) and (2) with numerical values for  $\bar{h}$  and  $\Delta T_{L/2}$ , find

$$q_s'' = 2.38 \text{ W/m}^2 \cdot \text{K} \times 10.4^\circ\text{C} = 24.8 \text{ W/m}^2. \quad <$$

**COMMENTS:** Recognize that radiation exchange with the environment will be significant.

Assuming  $\bar{T}_s = T_{L/2}$ ,  $T_{\text{sur}} = T_\infty$  and  $\varepsilon = 1$ , find  $q_{\text{rad}}'' = \sigma (\bar{T}_s^4 - T_{\text{sur}}^4) = 66 \text{ W/m}^2$ .

### PROBLEM 9.29

**KNOWN:** Vertical circuit board dissipating 5W to ambient air.

**FIND:** (a) Maximum temperature of the board assuming uniform surface heat flux and (b) Temperature of the board for an isothermal surface condition.

**SCHEMATIC:**

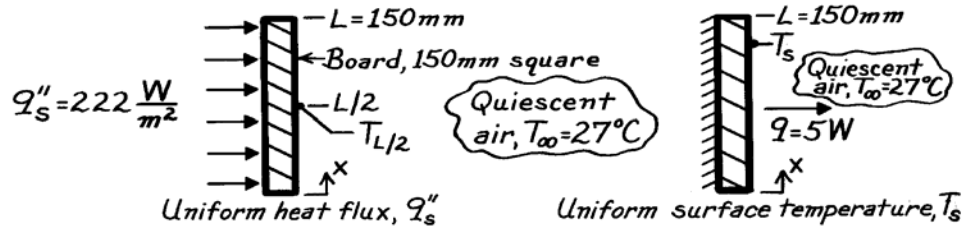

**ASSUMPTIONS:** (1) Either uniform  $q_s''$  or  $T_s$  on the board, (2) Quiescent room air.

**PROPERTIES:** Table A-4, Air ( $T_f = (T_{L/2} + T_\infty)/2$  or  $(T_s + T_\infty)/2$ , 1 atm), values used in iterations:

Iteration	$T_f$ (K)	$\nu \cdot 10^6$ (m <sup>2</sup> /s)	$k \cdot 10^3$ (W/m·K)	$\alpha \cdot 10^6$ (m <sup>2</sup> /s)	Pr
1	312	17.10	27.2	24.3	0.705
2	324	18.30	28.1	26.1	0.704
3	319	17.80	27.7	25.3	0.704
4	320	17.90	27.8	25.4	0.704

**ANALYSIS:** (a) For the uniform heat flux case (see Section 9.6.1), the heat flux is

$$q_s'' = \bar{h} \Delta T_{L/2} \quad \text{where} \quad \Delta T_{L/2} = T_{L/2} - T_\infty \quad (1,2)$$

and  $q_s'' = q / A_s = 5 \text{ W} / (0.150 \text{ m})^2 = 222 \text{ W} / \text{m}^2$ .

The maximum temperature on the board will occur at  $x = L$  and from Eq. 9.28 is

$$\Delta T_x = 1.15 (x/L)^{1/5} \Delta T_{L/2} \quad (3)$$

$$T_L = T_{\max} = T_\infty + 1.15 \Delta T_{L/2}.$$

The average heat transfer coefficient  $\bar{h}$  is estimated from a vertical (uniform  $T_s$ ) plate correlation based upon the temperature difference  $\Delta T_{L/2}$ . Recognize that an iterative procedure is required: (i) assume a value of  $T_{L/2}$ , use Eq. (2) to find  $\Delta T_{L/2}$ ; (ii) evaluate the Rayleigh number

$$Ra_L = g \beta \Delta T_{L/2} L^3 / \nu \alpha \quad (4)$$

and select the appropriate correlation (either Eq. 9.26 or 9.27) to estimate  $\bar{h}$ ; (iii) use Eq. (1) with values of  $\bar{h}$  and  $\Delta T_{L/2}$  to find the calculated value of  $q_s''$ ; and (iv) repeat this procedure until the calculated value for  $q_s''$  is close to  $q_s'' = 222 \text{ W} / \text{m}^2$ , the required heat flux.

Continued ...

**PROBLEM 9.29 (Cont.)**

To evaluate properties for the correlation, use the film temperature,

$$T_f = (T_{L/2} + T_\infty) / 2. \quad (5)$$

Iteration #1: Assume  $T_{L/2} = 50^\circ\text{C}$  and from Eqs. (2) and (5) find

$$\Delta T_{L/2} = (50 - 27)^\circ\text{C} = 23^\circ\text{C} \quad T_f = (50 + 27)^\circ\text{C} / 2 = 312\text{K}.$$

From Eq. (4), with  $\beta = 1/T_f$ , the Rayleigh number is

$$\text{Ra}_L = 9.8\text{m/s}^2 (1/312\text{K}) \times 23^\circ\text{C} (0.150\text{m})^3 / \left(17.10 \times 10^{-6} \text{m}^2/\text{s}\right) \times \left(24.3 \times 10^{-6} \text{m}^2/\text{s}\right) = 5.868 \times 10^6.$$

Since  $\text{Ra}_L < 10^9$ , the flow is laminar and Eq. 9.27 is appropriate

$$\overline{\text{Nu}}_L = \frac{\bar{h}L}{k} = 0.68 + \frac{0.670 \text{Ra}_L^{1/4}}{\left[1 + (0.492/\text{Pr})^{9/16}\right]^{4/9}}$$

$$\bar{h}_L = \frac{0.0272 \text{W/m}\cdot\text{K}}{0.150\text{m}} \left\{ 0.68 + 0.670 \left(5.868 \times 10^6\right)^{1/4} / \left[1 + (0.492/0.705)^{9/16}\right]^{4/9} \right\} = 4.71 \text{W/m}^2 \cdot \text{K}.$$

Using Eq. (1), the calculated heat flux is

$$q_s'' = 4.71 \text{W/m}^2 \cdot \text{K} \times 23^\circ\text{C} = 108 \text{W/m}^2.$$

Since  $q_s'' < 222 \text{W/m}^2$ , the required value, another iteration with an increased estimate for  $T_{L/2}$  is warranted. Further iteration results are tabulated.

Iteration	$T_{L/2}(\text{C})$	$\Delta T_{L/2}(\text{C})$	$T_f(\text{K})$	$\text{Ra}_L$	$\bar{h}(\text{W/m}^2 \cdot \text{K})$	$q_s''(\text{W/m}^2)$
2	75	48	324	$1.026 \times 10^7$	5.57	268
3	65	38	319	$8.749 \times 10^6$	5.29	201
4	68	41	320	$9.321 \times 10^6$	5.39	221

After Iteration 4, close agreement between the calculated and required  $q_s''$  is achieved with

$T_{L/2} = 68^\circ\text{C}$ . From Eq. (3), the maximum board temperature is

$$T_L = T_{\text{max}} = 27^\circ\text{C} + 1.15(41)^\circ\text{C} = 74^\circ\text{C}. \quad <$$

(b) For the uniform temperature case, the procedure for estimation of the average heat transfer coefficient is the same. Hence,

$$T_s = T_{L/2} | q_s'' = 68^\circ\text{C}. \quad <$$

**COMMENTS:** In both cases,  $q = 5\text{W}$  and  $\bar{h} = 5.38 \text{W/m}^2$ . However, the temperature distributions for the two cases are quite different as shown on the sketch. For  $q_s'' = \text{constant}$ ,  $\Delta T_x \sim x^{1/5}$  according to Eq. 9.28.

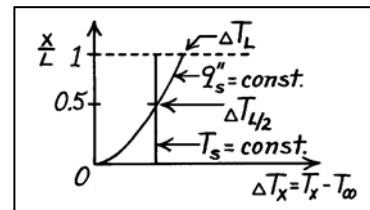

### PROBLEM 9.30

**KNOWN:** Coolant flow rate and inlet and outlet temperatures. Dimensions and emissivity of channel side walls. Temperature of surroundings. Power dissipation.

**FIND:** (a) Temperature of sidewalls for  $\varepsilon_s = 0.15$ , (b) Temperature of sidewalls for  $\varepsilon_s = 0.90$ , (c) Sidewall temperatures with loss of coolant for  $\varepsilon_s = 0.15$  and  $\varepsilon_s = 0.90$ .

**SCHEMATIC:**

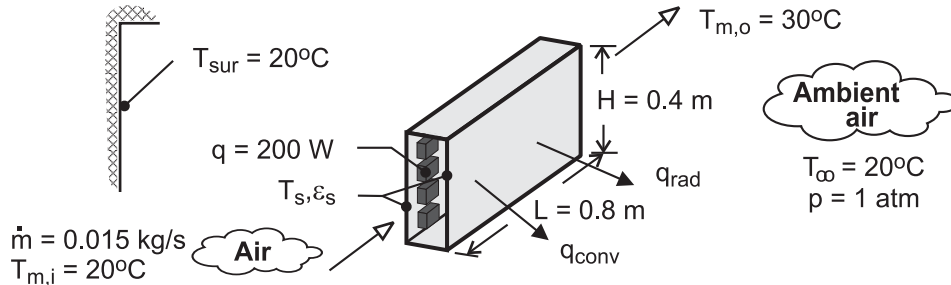

**ASSUMPTIONS:** (1) Steady-state, (2) Negligible heat transfer from top and bottom surfaces of duct, (3) Isothermal side walls, (4) Large surroundings, (5) Coolant is incompressible liquid with negligible viscous dissipation, (6) Constant properties.

**PROPERTIES:** Table A-4, air ( $\bar{T}_m = 298 \text{ K}$ ):  $c_p = 1007 \text{ J/kg}\cdot\text{K}$ . Air properties required for the free convection calculations depend on  $T_s$  and were evaluated as part of the iterative solution obtained using the IHT software.

**ANALYSIS:** (a) The heat dissipated by the components is transferred by forced convection to the coolant ( $q_c$ ), as well as by natural convection ( $q_{\text{conv}}$ ) and radiation ( $q_{\text{rad}}$ ) to the ambient air and the surroundings. Hence,

$$q = q_c + q_{\text{conv}} + q_{\text{rad}} = 200 \text{ W} \quad (1)$$

$$q_c = \dot{m}c_p(T_{m,o} - T_{m,i}) = 0.015 \text{ kg/s} \times 1007 \text{ J/kg}\cdot\text{K} \times 10^\circ\text{C} = 151 \text{ W} \quad (2)$$

$$q_{\text{conv}} = 2\bar{h}A_s(T_s - T_\infty) \quad (3)$$

where  $A_s = H \times L = 0.32 \text{ m}^2$  and  $\bar{h}$  is obtained from Eq. 9.26, with  $Ra_H = g\beta(T_s - T_\infty)H^3 / \alpha\nu$ .

$$\bar{h} = \frac{k}{H} \left\{ 0.825 + \frac{0.387 Ra_H^{1/6}}{\left[ 1 + (0.492/Pr)^{9/16} \right]^{8/27}} \right\}^2 \quad (3a)$$

$$q_{\text{rad}} = 2A_s \varepsilon_s \sigma (T_s^4 - T_{\text{sur}}^4) \quad (4)$$

Substituting Eqs. (2) – (4) into (1) and solving using the IHT software with  $\varepsilon_s = 0.15$ , we obtain

$$T_s = 308.8 \text{ K} = 35.8^\circ\text{C} \quad <$$

The corresponding heat rates are  $q_{\text{conv}} = 39.6 \text{ W}$  and  $q_{\text{rad}} = 9.4 \text{ W}$ .

(b) For  $\varepsilon_s = 0.90$  and  $q_c = 151 \text{ W}$ , the solution to Eqs. (1) – (4) yields

Continued ...

**PROBLEM 9.30 (Cont.)**

$$T_s = 301.8 \text{ K} = 28.8^\circ\text{C} \quad <$$

with  $q_{\text{conv}} = 18.7 \text{ W}$  and  $q_{\text{rad}} = 30.3 \text{ W}$ . Hence, enhanced emission from the surface yields a lower operating temperature and heat transfer by radiation now exceeds that due to conduction.

(c) With loss of coolant flow, we can expect all of the heat to be dissipated from the sidewalls ( $q_c = 0$ ). Solving Eqs. (1), (3) and (4), we obtain

$$\varepsilon_s = 0.15: \quad T_s = 341.8 \text{ K} = 68.8^\circ\text{C} \quad <$$

$$q_{\text{conv}} = 165.9 \text{ W}, \quad q_{\text{rad}} = 34.1 \text{ W}$$

$$\varepsilon_s = 0.90: \quad T_s = 322.5 \text{ K} = 49.5^\circ\text{C} \quad <$$

$$q_{\text{conv}} = 87.6 \text{ W}, \quad q_{\text{rad}} = 112.4 \text{ W}$$

Since the temperature of the electronic components exceeds that of the sidewalls, the value of  $T_s = 68.8^\circ\text{C}$  corresponding to  $\varepsilon_s = 0.15$  may be unacceptable, in which case the high emissivity coating should be applied to the walls.

**COMMENTS:** For the foregoing cases the convection coefficient is in the range  $3.31 \leq \bar{h} \leq 5.31 \text{ W/m}^2 \cdot \text{K}$ , with the smallest value corresponding to ( $q_c = 151 \text{ W}$ ,  $\varepsilon_s = 0.90$ ) and the largest value to ( $q_c = 0$ ,  $\varepsilon_s = 0.15$ ). The radiation coefficient is in the range  $0.93 \leq h_{\text{rad}} \leq 5.96 \text{ W/m}^2 \cdot \text{K}$ , with the smallest value corresponding to ( $q_c = 151 \text{ W}$ ,  $\varepsilon_s = 0.15$ ) and the largest value to ( $q_c = 0$ ,  $\varepsilon_s = 0.90$ ).

### PROBLEM 9.31

**KNOWN:** Dimensions, interior surface temperature, and exterior surface emissivity of a refrigerator door. Temperature of ambient air and surroundings.

**FIND:** (a) Heat gain with no insulation, (b) Heat gain as a function of thickness for polystyrene insulation.

**SCHEMATIC:**

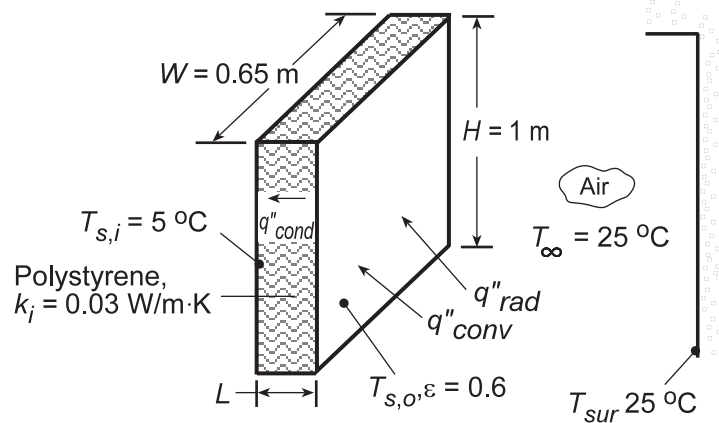

**ASSUMPTIONS:** (1) Steady-state conditions, (2) Negligible thermal resistance of steel and polypropylene sheets, (3) Negligible contact resistance between sheets and insulation, (4) One-dimensional conduction in insulation, (5) Quiescent air.

**PROPERTIES:** Table A.4, air ( $T_f = 288 \text{ K}$ ):  $\nu = 14.82 \times 10^{-6} \text{ m}^2/\text{s}$ ,  $\alpha = 20.92 \times 10^{-6} \text{ m}^2/\text{s}$ ,  $k = 0.0253 \text{ W/m}\cdot\text{K}$ ,  $\text{Pr} = 0.71$ ,  $\beta = 0.00347 \text{ K}^{-1}$ .

**ANALYSIS:** (a) Without insulation,  $T_{s,o} = T_{s,i} = 278 \text{ K}$  and the heat gain is

$$q_{wo} = \bar{h}A_s(T_\infty - T_{s,i}) + \varepsilon\sigma A_s(T_{sur}^4 - T_{s,i}^4)$$

where  $A_s = HW = 0.65 \text{ m}^2$ . With a Rayleigh number of  $\text{Ra}_H = g\beta(T_\infty - T_{s,i})H^3/\alpha\nu = 9.8 \text{ m/s}^2(0.00347 \text{ K}^{-1})(20 \text{ K})(1)^3/(20.92 \times 10^{-6} \text{ m}^2/\text{s})(14.82 \times 10^{-6} \text{ m}^2/\text{s}) = 2.19 \times 10^9$ , Eq. 9.26 yields

$$\bar{\text{Nu}}_H = \left\{ 0.825 + \frac{0.387(2.19 \times 10^9)^{1/6}}{\left[1 + (0.492/0.71)^{9/16}\right]^{8/27}} \right\}^2 = 156.6$$

$$\bar{h} = \bar{\text{Nu}}_H(k/H) = 156.6(0.0253 \text{ W/m}\cdot\text{K}/1 \text{ m}) = 4.0 \text{ W/m}^2\cdot\text{K}$$

$$q_{wo} = 4.0 \text{ W/m}^2\cdot\text{K}(0.65 \text{ m}^2)(20 \text{ K}) + 0.6(5.67 \times 10^{-8} \text{ W/m}^2\cdot\text{K}^4)(0.65 \text{ m}^2)(298^4 - 278^4) \text{ K}^4$$

$$q_{wo} = (52.00 + 42.3) \text{ W} = 94.3 \text{ W} \quad \leftarrow$$

(b) With the insulation,  $T_{s,o}$  may be determined by performing an energy balance at the outer surface, where  $q''_{conv} + q''_{rad} = q''_{cond}$ , or

$$\bar{h}(T_\infty - T_{s,o}) + \varepsilon\sigma(T_{sur}^4 - T_{s,o}^4) = \frac{k_i}{L}(T_{s,o} - T_{s,i})$$

Using the *IHT First Law Model* for a *Nonisothermal Plane Wall* with the appropriate *Correlations* and *Properties* Tool Pads and evaluating the heat gain from

Continued...

### PROBLEM 9.31 (Cont.)

$$q_w = \frac{k_i A_s}{L} (T_{s,o} - T_{s,i})$$

the following results are obtained for the effect of  $L$  on  $T_{s,o}$  and  $q_w$ .

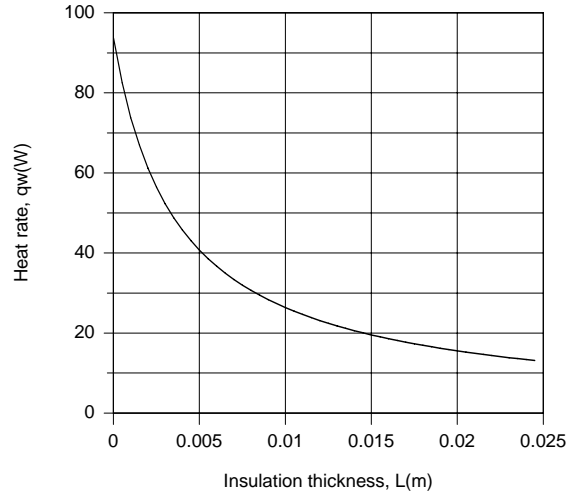
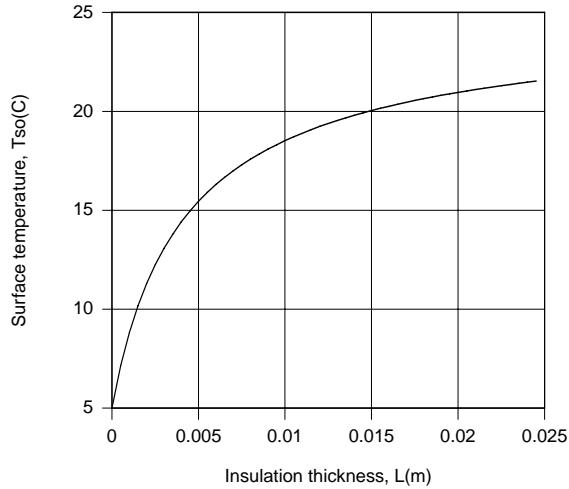

The outer surface temperature increases with increasing  $L$ , causing a reduction in the rate of heat transfer to the refrigerator compartment. For  $L = 0.025$  m,  $\bar{h} = 2.29$  W/m<sup>2</sup>·K,  $h_{\text{rad}} = 3.54$  W/m<sup>2</sup>·K,  $q_{\text{conv}} = 5.16$  W,  $q_{\text{rad}} = 7.99$  W,  $q_w = 13.15$  W, and  $T_{s,o} = 21.5^\circ\text{C}$ .

**COMMENTS:** The insulation is very effective in reducing the heat load, and there would be little value to increasing  $L$  beyond 25 mm.

### PROBLEM 9.32

**KNOWN:** Air receiving tank of height 2.5 m and diameter 0.75 m; inside air is at 3 atm and 100°C while outside ambient air is 25°C.

**FIND:** (a) Receiver wall temperature and heat transfer to the ambient air; assume receiver wall is  $T_s = 60^\circ\text{C}$  to facilitate use of the free convection correlations; (b) Whether film temperatures  $T_{f,i}$  and  $T_{f,o}$  were reasonable; if not, use an iteration procedure to find consistent values; and (c) Receiver wall temperatures,  $T_{s,i}$  and  $T_{s,o}$ , considering radiation exchange from the exterior surface ( $\epsilon_{s,o} = 0.85$ ) and thermal resistance of the wall (20 mm thick,  $k = 0.25\text{W/m}\cdot\text{K}$ ); represent the system by a thermal circuit.

**SCHEMATIC:**

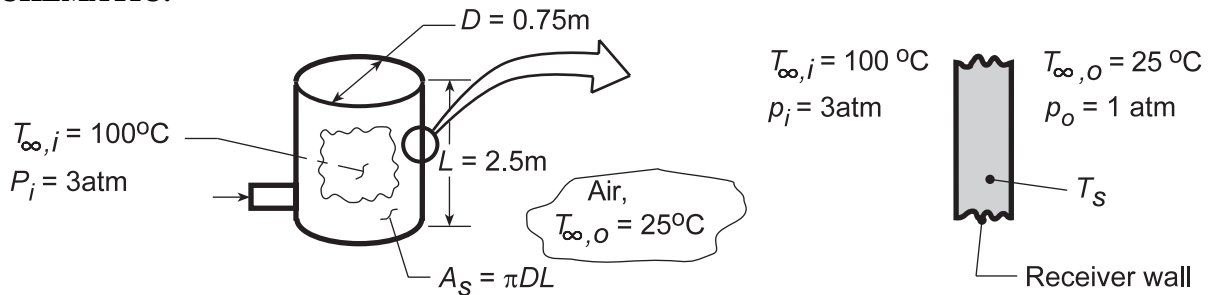

**ASSUMPTIONS:** (1) Surface radiation effects are negligible, parts (a,b), (2) Losses from top and bottom of receiver are negligible, (3) Thermal resistance of receiver wall is negligible compared to free convection resistance, parts (a,b), (4) Interior and exterior air is quiescent and extensive.

**PROPERTIES:** Table A-4, Air (assume  $T_{f,o} = 315\text{ K}$ , 1 atm):  $\nu = 1.74 \times 10^{-5}\text{ m}^2/\text{s}$ ,  $k = 0.02741\text{ W/m}\cdot\text{K}$ ,  $\alpha = 2.472 \times 10^{-5}\text{ m}^2/\text{s}$ ,  $\text{Pr} = 0.7049$ ; Table A-4, Air (assume  $T_{f,i} = 350\text{ K}$ , 3 atm):  $\nu = 2.092 \times 10^{-5}\text{ m}^2/\text{s}/3 = 6.973 \times 10^{-6}\text{ m}^2/\text{s}$ ,  $k = 0.030\text{ W/m}\cdot\text{K}$ ,  $\alpha = 2.990 \times 10^{-5}\text{ m}^2/\text{s}/3 = 9.967 \times 10^{-6}\text{ m}^2/\text{s}$ ,  $\text{Pr} = 0.700$ . Note that the pressure effect is present for  $\nu$  and  $\alpha$  since  $\rho(1\text{ atm}) = 1/3\rho(3\text{ atm})$ ; other properties ( $c_p$ ,  $k$ ,  $\mu$ ) are assumed independent of pressure.

**ANALYSIS:** The heat transfer rate from the receiver follows from the thermal circuit,

$$q = \frac{\Delta T}{R_t} = \frac{T_{\infty,i} - T_{\infty,o}}{1/\bar{h}_o A_s + 1/\bar{h}_i A_s} = \frac{A_s (T_{\infty,i} - T_{\infty,o})}{1/\bar{h}_o + 1/\bar{h}_i} \quad (1)$$

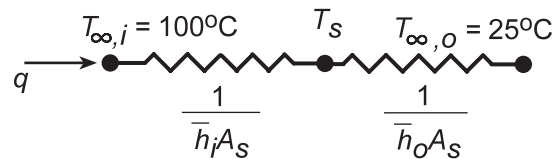

where  $\bar{h}_o$  and  $\bar{h}_i$  must be estimated from free convection correlations. We must assume a value of  $T_s$  in order to obtain first estimates for  $\Delta T_o = T_s - T_{\infty,o}$  and  $\Delta T_i = T_{\infty,o} - T_s$  as well as  $T_{f,o}$  and  $T_{f,i}$ . Assume that  $T_s = 60^\circ\text{C}$ , then  $\Delta T_o = 60 - 25 = 35^\circ\text{C}$ ,  $T_{f,o} = 315\text{ K}$  and  $\Delta T_i = 100 - 60 = 40^\circ\text{C}$ , and  $T_{f,i} = 350\text{ K}$ .

$$\text{Ra}_{L,o} = \frac{g\beta\Delta T L^3}{\nu\alpha} = \frac{9.8\text{ m/s}^2 (1/315\text{ K}) \times 35\text{ K} (2.5\text{ m})^3}{1.74 \times 10^{-5}\text{ m}^2/\text{s} \times 2.472 \times 10^{-5}\text{ m}^2/\text{s}} = 3.952 \times 10^{10}$$

$$\text{Ra}_{L,i} = \frac{9.8\text{ m/s}^2 (1/350\text{ K}) \times 40\text{ K} (2.5\text{ m})^3}{6.973 \times 10^{-6}\text{ m}^2/\text{s} \times 9.967 \times 10^{-6}\text{ m}^2/\text{s}} = 2.518 \times 10^{11}$$

Approximating the receiver wall as a vertical plate, Eq. 9.26 yields

Continued...



**PROBLEM 9.32 (Cont.)**

$$\overline{\text{Nu}}_{L,o} = \left[ 0.825 + \frac{0.387 \text{Ra}_{L,o}^{1/6}}{\left[ 1 + (0.492/\text{Pr})^{9/16} \right]^{8/27}} \right]^2 = \left[ 0.825 + \frac{0.387 (3.952 \times 10^{10})^{1/6}}{\left[ 1 + (0.492/0.7049)^{9/16} \right]^{8/27}} \right]^2 = 390.0$$

$$\overline{\text{Nu}}_{L,i} = \frac{\bar{h}_{L,i} L}{k} = \left[ 0.825 + \frac{0.387 (2.518 \times 10^{11})^{1/6}}{\left[ 1 + (0.492/0.700)^{9/16} \right]^{8/27}} \right]^2 = 706.4$$

$$\bar{h}_{L,o} = \frac{0.02741 \text{ W/m} \cdot \text{K}}{2.5 \text{ m}} \times 390.0 = 4.27 \text{ W/m}^2 \cdot \text{K} \quad \bar{h}_{L,i} = \frac{0.030 \text{ W/m} \cdot \text{K}}{2.5 \text{ m}} \times 706.4 = 8.48 \text{ W/m}^2 \cdot \text{K}$$

From Eq. (1),

$$q = \pi \times 0.75 \text{ m} \times 2.5 \text{ m} (100 - 25) \text{ K} / \left[ \frac{1}{4.27} + \frac{1}{8.48} \right] \text{ m}^2 / \text{K} \cdot \text{W} = 1225 \text{ W} \quad <$$

Also,

$$T_s = T_{\infty,i} - q / \bar{h}_i A_s = 100^\circ \text{C} - 1225 \text{ W} / (8.48 \text{ W/m}^2 \cdot \text{K} \times \pi \times 0.75 \text{ m} \times 2.5 \text{ m}) = 74.9^\circ \text{C} <$$

(b) From the above result for  $T_s$ , the computed film temperatures are

$$T_{f,o} = 323 \text{ K} \quad T_{f,i} = 360 \text{ K}$$

as compared to assumed values of 315 and 350 K, respectively. Using *IHT Correlation Tools* for the *Free Convection, Vertical Plate*, and the thermal circuit representing Eq. (1) to find  $T_s$ , rather than using as assumed value,

$$\frac{T_{\infty,o} - T_s}{1/\bar{h}_o} = \frac{T_s - T_{\infty,o}}{1/\bar{h}_o}$$

we found

$$q = 1262 \text{ W} \quad T_s = 71.4^\circ \text{C} \quad <$$

with  $T_{f,o} = 321 \text{ K}$  and  $359 \text{ K}$ . The iteration only influenced the heat rate slightly.

(c) Considering effects due to thermal resistance of the tank wall and radiation exchange, the thermal resistance network representing the system is shown below.

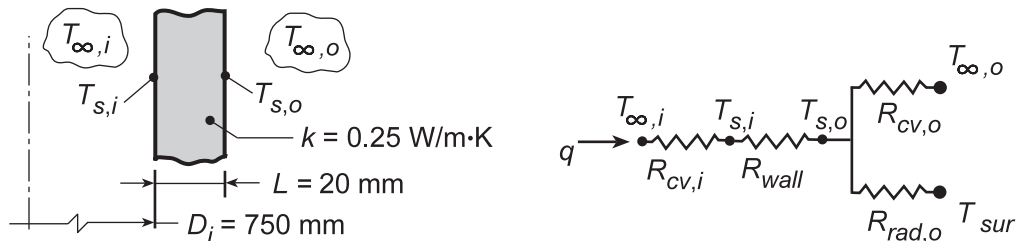

Continued ...

### PROBLEM 9.32 (Cont.)

Using the *IHT Model, Thermal Network*, with the *Correlation Tool for Free Convection, Vertical Plate*, and *Properties Tool for Air*, a model was developed which incorporates all the foregoing equations of parts (a,b), but includes the thermal resistance of the wall, Table 3.3,

$$R_{\text{wall}} = \frac{\ln(D_i/D_o)}{2\pi Lk} \quad D_o = D_i + 2 \times t$$

The results of the analyses are tabulated below showing for comparison those from parts (a) and (b):

Part	$R_{\text{cv},i}$ (K/W)	$R_w$ (K/W)	$R_{\text{cv},o}$ (K/W)	$R_{\text{rad}}$ (K/W)	$T_{s,i}$ (°C)	$T_{s,o}$ (°C)	$q$ W
(a)	0.0200	0	0.0398	$\infty$	74.9*	74.9*	1255
(b)	0.0227	0	0.0367	$\infty$	71.4	71.4	1262
(c)	0.0219	0.0132	0.0419	0.0280	68.4	49.3	1445

\*Recall we assumed  $T_s = 60^\circ\text{C}$  in order to simplify the correlation calculation with fixed values of  $\Delta T_i$ ,  $\Delta T_o$  as well as  $T_{f,o}$ ,  $T_{f,i}$ .

**COMMENTS:** (1) In the table note the slight difference between results using assumed values for  $T_f$  and  $\Delta T$  in the correlations (part (a)) and the exact solution (part (b)).

(2) In the part (c) results, considering thermal resistance of the wall and the radiation exchange process, the net effect was to reduce the overall thermal resistance of the system and, hence, the heat rate increased.

(3) In the part (c) analysis, the *IHT Thermal Resistance Network* model was used to create the thermal circuit and generate the required energy balances. The convection resistances were determined from appropriate *Convection Correlation Tools*. The code was developed in two steps: (1) Solve the energy balance relations from the *Network* with assigned values for  $h_i$  and  $h_o$  to demonstrate that the energy relations were correct and then (2) Call in the *Convection Correlations* and solve with variable coefficients. Because this equation set is very stiff, we used the intrinsic heat transfer function *Tfluid\_avg* and followed these steps in the solution: Step (1): Assign constant values to the film temperatures,  $T_{fi}$  and  $T_{fo}$ , and to the temperature differences in the convection correlations,  $\Delta T_i$  and  $\Delta T_o$ ; and in the *Initial Guesses* table, restrain all thermal resistances to be positive (minimum value = 1e-20); *Solve*; Step (2): Allow the film temperatures to be unknowns but keep assigned variables for the temperature differences; use the *Load* option and *Solve*. Step (3): Repeat the previous step but allowing the temperature differences to be unknowns. Even though you get a "successful solve" message, repeat the *Load-Solve* sequence until you see no changes in key variables so that you are assured that the Solver has fully converged on the solution.

### PROBLEM 9.33

**KNOWN:** Dimensions and emissivity of cylindrical solar receiver. Incident solar flux. Temperature of ambient air.

**FIND:** (a) Heat loss and collection efficiency for a prescribed receiver temperature, (b) Effect of receiver temperature on heat losses and collector efficiency.

**SCHEMATIC:**

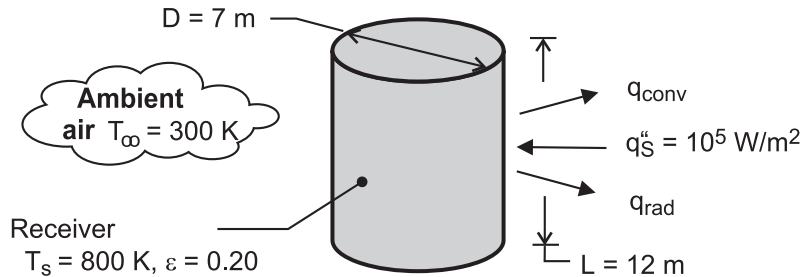

**ASSUMPTIONS:** (1) Steady-state, (2) Ambient air is quiescent, (3) Incident solar flux is uniformly distributed over receiver surface, (4) All of the incident solar flux is absorbed by the receiver, (5) Negligible irradiation from the surroundings, (6) Uniform receiver surface temperature, (7) Curvature of cylinder has a negligible effect on boundary layer development, (8) Constant properties.

**PROPERTIES:** Table A-4, air ( $T_f = 550$  K):  $k = 0.0439$  W/m·K,  $\nu = 45.6 \times 10^{-6}$  m<sup>2</sup>/s,  $\alpha = 66.7 \times 10^{-6}$  m<sup>2</sup>/s,  $Pr = 0.683$ ,  $\beta = 1.82 \times 10^{-3}$  K<sup>-1</sup>.

**ANALYSIS:** (a) The total heat loss is

$$q = q_{\text{rad}} + q_{\text{conv}} = A_s \varepsilon \sigma T_s^4 + \bar{h} A_s (T_s - T_\infty)$$

With  $Ra_L = g\beta(T_s - T_\infty)L^3/\nu\alpha = 9.8 \text{ m/s}^2 (1.82 \times 10^{-3} \text{ K}^{-1}) 500\text{K} (12\text{m})^3 / (45.6 \times 66.7 \times 10^{-12} \text{ m}^4/\text{s}^2) = 5.07 \times 10^{12}$ , Eq. 9.26 yields

$$\bar{h} = \frac{k}{L} \left\{ 0.825 + \frac{0.387 Ra_L^{1/6}}{\left[ 1 + (0.492/Pr)^{9/16} \right]^{8/27}} \right\}^2 = \frac{0.0439 \text{ W/m}\cdot\text{K}}{12\text{m}} \{0.825 + 42.4\}^2 = 6.83 \text{ W/m}^2 \cdot \text{K}$$

Hence, with  $A_s = \pi DL = 264 \text{ m}^2$

$$q = 264 \text{ m}^2 \times 0.2 \times 5.67 \times 10^{-8} \text{ W/m}^2 \cdot \text{K}^4 (800 \text{ K})^4 + 264 \text{ m}^2 \times 6.83 \text{ W/m}^2 \cdot \text{K} (500 \text{ K})$$

$$q = q_{\text{rad}} + q_{\text{conv}} = 1.23 \times 10^6 \text{ W} + 9.01 \times 10^5 \text{ W} = 2.13 \times 10^6 \text{ W} \quad <$$

With  $A_s q_s'' = 2.64 \times 10^7 \text{ W}$ , the collector efficiency is

$$\eta = \left( \frac{A_s q_s'' - q}{A_s q_s''} \right) 100 = \frac{(2.64 \times 10^7 - 2.13 \times 10^6) \text{ W}}{2.64 \times 10^7 \text{ W}} (100) = 91.9\% \quad <$$

Continued ...

### PROBLEM 9.33 (Cont.)

(b) As shown below, because of its dependence on temperature to the fourth power,  $q_{\text{rad}}$  increases more significantly with increasing  $T_s$  than does  $q_{\text{conv}}$ , and the effect on the efficiency is pronounced.

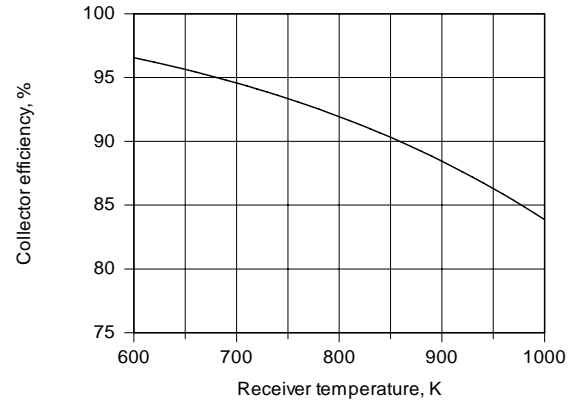
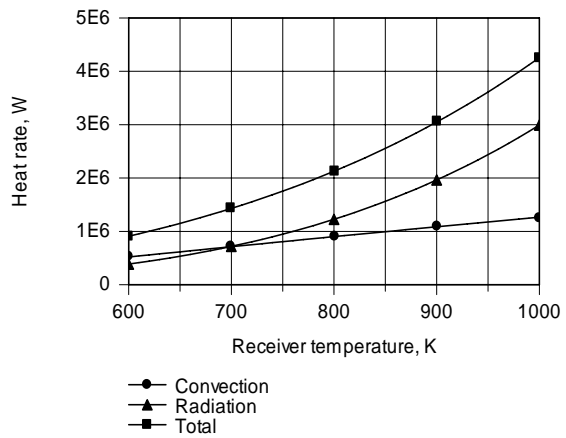

**COMMENTS:** The collector efficiency is also reduced by the inability to have a perfectly absorbing receiver. Partial reflection of the incident solar flux will reduce the efficiency by at least several percent.

### PROBLEM 9.34

**KNOWN:** Transformer which dissipates 1000 W whose surface is to be maintained at 47°C in quiescent air and surroundings at 27°C.

**FIND:** Power removal (a) by free convection and radiation from lateral and upper horizontal surfaces and (b) with 30 vertical fins attached to lateral surface.

**SCHEMATIC:**

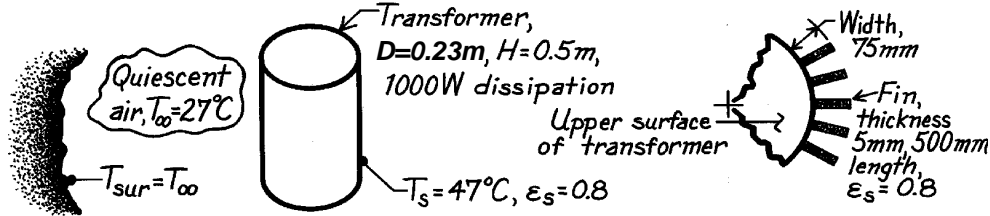

**ASSUMPTIONS:** (1) Fins are isothermal at lateral surface temperature,  $T_s$ , (2) Vertical fins and lateral surface behave as vertical plate, (3) Transformer has isothermal surfaces and loses heat only on top and side.

**PROPERTIES:** Table A-4, Air ( $T_f = (27+47)^\circ\text{C}/2 = 310\text{K}$ , 1 atm):  $\nu = 16.90 \times 10^{-6} \text{ m}^2/\text{s}$ ,  $k = 27.0 \times 10^{-3} \text{ W/m}\cdot\text{K}$ ,  $\alpha = 23.98 \times 10^{-6} \text{ m}^2/\text{s}$ ,  $\text{Pr} = 0.706$ ,  $\beta = 1/T_f$ .

**ANALYSIS:** (a) For the vertical lateral (lat) and top horizontal (top) surfaces, the heat loss by radiation and convection is

$$q = q_{\text{lat}} + q_{\text{top}} = (\bar{h}_{\text{lat}} + h_r) \pi D L (T_s - T_\infty) + (\bar{h}_{\text{top}} + h_r) \left( \pi^2 D / 4 \right) (T_s - T_\infty)$$

where, from Eq. 1.9, the linearized radiation coefficient is

$$h_r = \varepsilon \sigma (T_s + T_\infty) (T_s^2 + T_\infty^2)$$

$$h_r = 0.8 \times 5.67 \times 10^{-8} \text{ W/m}^2 \cdot \text{K}^4 (320 + 300) \text{ K} (320^2 + 300^2) \text{ K}^2 = 5.41 \text{ W/m}^2 \cdot \text{K}.$$

The free convection coefficient for the lateral and top surfaces is:

*Lateral-vertical plate:* Using Eq. 9.26 with

$$\text{Ra}_L = \frac{g \beta (T_s - T_\infty) H^3}{\nu \alpha} = \frac{9.8 \text{ m/s}^2 (1/310 \text{ K}) (47 - 27) \text{ K} (0.5 \text{ m})^3}{16.90 \times 10^{-6} \text{ m}^2/\text{s} \times 23.98 \times 10^{-6} \text{ m}^2/\text{s}} = 1.950 \times 10^8$$

$$\bar{\text{Nu}}_L = \left\{ 0.825 + \frac{0.387 \text{Ra}_L^{1/6}}{\left[ 1 + (0.492/\text{Pr})^{9/16} \right]^{8/27}} \right\}^2$$

$$\bar{\text{Nu}}_L = \left\{ 0.825 + \frac{0.387 (1.950 \times 10^8)^{1/6}}{\left[ 1 + (0.492/0.706)^{9/16} \right]^{8/27}} \right\}^2 = 74.5$$

$$\bar{h}_{\text{lat}} = \bar{\text{Nu}}_L \cdot k / H = 74.5 \times 0.027 \text{ W/m}\cdot\text{K} / 0.5 \text{ m} = 4.02 \text{ W/m}^2 \cdot \text{K}.$$

Continued ...

**PROBLEM 9.34 (Cont.)**

*Top-horizontal plate:* Using Eq. 9.30 with

$$L_c = A_s / P = \frac{\pi D^2 / 4}{\pi D} = D / 4 = 0.0575 \text{ m}$$

$$Ra_L = \frac{g\beta(T_s - T_\infty)L_c^3}{\nu\alpha} = \frac{9.8 \text{ m/s}^2 (1/310 \text{ K})(47 - 27) \text{ K} (0.0575 \text{ m})^3}{16.90 \times 10^{-6} \text{ m}^2/\text{s} \times 23.98 \times 10^{-6} \text{ m}^2/\text{s}} = 2.97 \times 10^5$$

$$\overline{Nu}_L = 0.54 Ra_L^{1/4} = 0.54 (2.97 \times 10^5)^{1/4} = 12.6$$

$$\overline{h}_{\text{top}} = \overline{Nu}_L \cdot k / L_c = 12.6 \times 0.027 \text{ W/m} \cdot \text{K} / 0.0575 \text{ m} = 5.92 \text{ W/m}^2 \cdot \text{K}.$$

Hence, the heat loss by convection and radiation is

$$q = (4.02 + 5.41) \text{ W/m}^2 \cdot \text{K} (\pi \times 0.23 \text{ m} \times 0.50 \text{ m})(47 - 27) \text{ K} \\ + (5.92 + 5.41) \text{ W/m}^2 \cdot \text{K} (\pi \times 0.23^2 \text{ m}^2 / 4)(47 - 27) \text{ K}$$

$$q = (68.2 + 4.50) \text{ W} = 72.7 \text{ W}. \quad \leftarrow$$

(b) The effect of adding the vertical fins is to increase the area of the lateral surface to

$$A_{\text{wf}} = [\pi DH - 30(t \cdot H)] + 30 \times 2(w \cdot H)$$

$$A_{\text{wf}} = [\pi 0.23 \text{ m} \times 0.50 \text{ m} - 30(0.005 \times 0.500) \text{ m}^2] + 30 \times 2(0.075 \times 0.500) \text{ m}^2$$

$$A_{\text{wf}} = [0.361 - 0.075] \text{ m}^2 + 2.25 \text{ m}^2 = 2.536 \text{ m}^2.$$

where  $t$  and  $w$  are the thickness and width of the fins, respectively. Hence, the heat loss is now

$$q = q_{\text{lat}} + q_{\text{top}} = (\overline{h}_{\text{lat}} + h_r) A_{\text{wf}} (T_s - T_\infty) + q_{\text{top}}$$

$$q = (4.02 + 5.41) \text{ W/m}^2 \times 2.536 \text{ m}^2 \times 20 \text{ K} + 4.50 \text{ W} = 483 \text{ W}. \quad \leftarrow$$

Adding the fins to the lateral surface increases the heat loss by a factor of more than six.

**COMMENTS:** Since the fins are not likely to have 100% efficiency, our estimate is optimistic. Further, since the fins see one another, as well as the lateral surface, the radiative heat loss is over predicted.

### PROBLEM 9.35

**KNOWN:** Surface temperature of a long duct and ambient air temperature.

**FIND:** Heat gain to the duct per unit length of the duct.

**SCHEMATIC:**

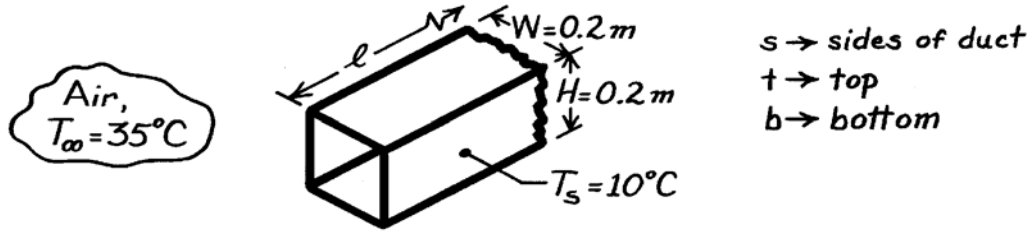

**ASSUMPTIONS:** (1) Surface radiation effects are negligible, (2) Ambient air is quiescent.

**PROPERTIES:** Table A-4, Air ( $T_f = (T_\infty + T_s)/2 \approx 300\text{K}$ , 1 atm):  $\nu = 15.89 \times 10^{-6} \text{ m}^2/\text{s}$ ,  $k = 0.0263 \text{ W/m}\cdot\text{K}$ ,  $\alpha = 22.5 \times 10^{-6} \text{ m}^2/\text{s}$ ,  $\text{Pr} = 0.707$ ,  $\beta = 1/T_f$ .

**ANALYSIS:** The heat gain to the duct can be expressed as

$$q' = 2q'_s + q'_t + q'_b = (2\bar{h}_s \cdot H + \bar{h}_t \cdot W + \bar{h}_b \cdot W)(T_\infty - T_s). \quad (1)$$

Consider now correlations to estimate  $\bar{h}_s$ ,  $\bar{h}_t$ , and  $\bar{h}_b$ . From Eq. 9.25, for the sides with  $L \equiv H$ ,

$$\text{Ra}_L = \frac{g\beta(T_\infty - T_s)L^3}{\nu\alpha} = \frac{9.8 \text{ m/s}^2 (1/300\text{K})(35 - 10) \text{ K} \times (0.2 \text{ m})^3}{15.89 \times 10^{-6} \text{ m}^2/\text{s} \times 22.5 \times 10^{-6} \text{ m}^2/\text{s}} = 1.827 \times 10^7. \quad (2)$$

Eq. 9.27 is appropriate to estimate  $\bar{h}_s$ ,

$$\bar{\text{Nu}}_L = 0.68 + \frac{0.670 \text{Ra}_L^{1/4}}{\left[1 + (0.492/\text{Pr})^{9/16}\right]^{4/9}} = 0.68 + \frac{0.670(1.827 \times 10^7)^{1/4}}{\left[1 + (0.492/0.707)^{9/16}\right]^{4/9}} = 34.29$$

$$\bar{h}_s = \bar{\text{Nu}}_L \cdot k/L = 34.29 \times 0.0263 \text{ W/m}\cdot\text{K} / 0.2 \text{ m} = 4.51 \text{ W/m}^2 \cdot \text{K}. \quad (3)$$

For the top and bottom portions of the duct,  $L \equiv A_s/P \approx W/2$ , (see Eq. 9.29), find the Rayleigh number from Eq. (2) with  $L = 0.1 \text{ m}$ ,  $\text{Ra}_L = 2.284 \times 10^6$ . From the correlations, Eqs. 9.30 and 9.32 for the top and bottom surfaces, respectively, find

$$\bar{h}_t = \frac{k}{(W/2)} \times 0.54 \text{Ra}_L^{1/4} = \frac{0.0263 \text{ W/m}\cdot\text{K}}{0.1 \text{ m}} \times 0.54 (2.284 \times 10^6)^{1/4} = 5.52 \text{ W/m}^2 \cdot \text{K}. \quad (4)$$

$$\bar{h}_b = \frac{k}{(W/2)} \times 0.52 \text{Ra}_L^{1/5} = \frac{0.0263 \text{ W/m}\cdot\text{K}}{0.1 \text{ m}} \times 0.52 (2.284 \times 10^6)^{1/5} = 2.56 \text{ W/m}^2 \cdot \text{K}. \quad (5)$$

The heat rate, Eq. (1), can now be evaluated using the heat transfer coefficients estimated from Eqs. (3), (4), and (5).

$$q' = (2 \times 4.51 \text{ W/m}^2 \cdot \text{K} \times 0.2 \text{ m} + 5.52 \text{ W/m}^2 \cdot \text{K} \times 0.2 \text{ m} + 2.56 \text{ W/m}^2 \cdot \text{K} \times 0.2 \text{ m})(35 - 10) \text{ K}$$

$$q' = 85.5 \text{ W/m}. \quad \leftarrow$$

**COMMENTS:** Radiation surface effects will be significant in this situation. With knowledge of the duct emissivity and surroundings temperature, the radiation heat exchange could be estimated.

### PROBLEM 9.36

**KNOWN:** Inner surface temperature and dimensions of rectangular duct. Thermal conductivity, thickness and emissivity of insulation.

**FIND:** (a) Outer surface temperatures and heat losses from the walls, (b) Effect of insulation thickness on outer surface temperatures and heat losses.

**SCHEMATIC:**

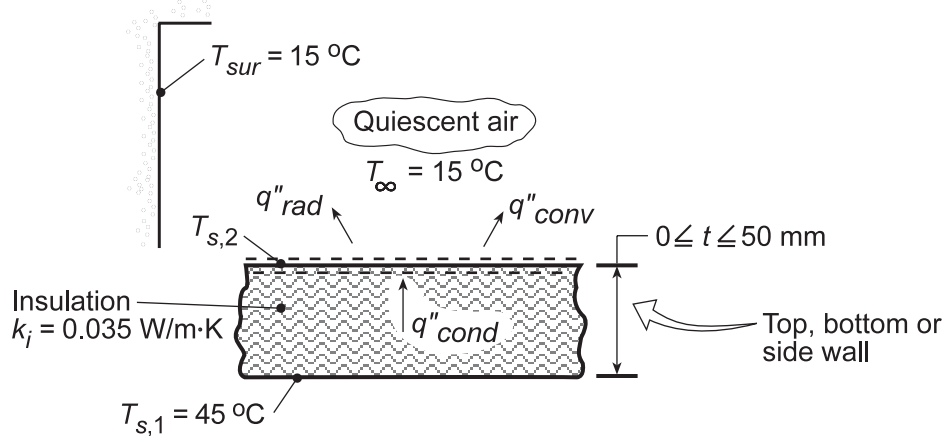

**ASSUMPTIONS:** (1) Ambient air is quiescent, (2) One-dimensional conduction, (3) Steady-state.

**PROPERTIES:** Table A.4, air (obtained from *Properties* Tool Pad of IHT).

**ANALYSIS:** (a) The analysis follows that of Example 9.3, except the surface energy balance must now include the effect of radiation. Hence,  $q''_{cond} = q''_{conv} + q''_{rad}$ , in which case

$$(k_i/t)(T_{s,1} - T_{s,2}) = \bar{h}(T_{s,2} - T_{\infty}) + h_r(T_{s,2} - T_{sur})$$

where  $h_r = \varepsilon\sigma(T_{s,2} + T_{sur})(T_{s,2}^2 + T_{sur}^2)$ . Applying this expression to each of the top, bottom and side walls, with the appropriate correlation obtained from the *Correlations* Tool Pad of IHT, the following results are determined for  $t = 25$  mm.

*Sides:*  $T_{s,2} = 19.3^{\circ}\text{C}$ ,  $\bar{h} = 2.82 \text{ W/m}^2\cdot\text{K}$ ,  $h_{rad} = 5.54 \text{ W/m}^2\cdot\text{K}$

*Top:*  $T_{s,2} = 19.3^{\circ}\text{C}$ ,  $\bar{h} = 2.94 \text{ W/m}^2\cdot\text{K}$ ,  $h_{rad} = 5.54 \text{ W/m}^2\cdot\text{K}$  <

*Bottom:*  $T_{s,2} = 20.1^{\circ}\text{C}$ ,  $\bar{h} = 1.34 \text{ W/m}^2\cdot\text{K}$ ,  $h_{rad} = 5.56 \text{ W/m}^2\cdot\text{K}$

With  $q'' = q''_{cond}$ , the surface heat losses may also be evaluated, and we obtain

*Sides:*  $q' = 2Hq'' = 21.6 \text{ W/m}$ ; *Top:*  $q' = wq'' = 27.0 \text{ W/m}$ ; *Bottom:*  $q' = wq'' = 26.2 \text{ W/m}$  <

(b) For the top surface, the following results are obtained from the parametric calculations

Continued...



### PROBLEM 9.36 (Cont.)

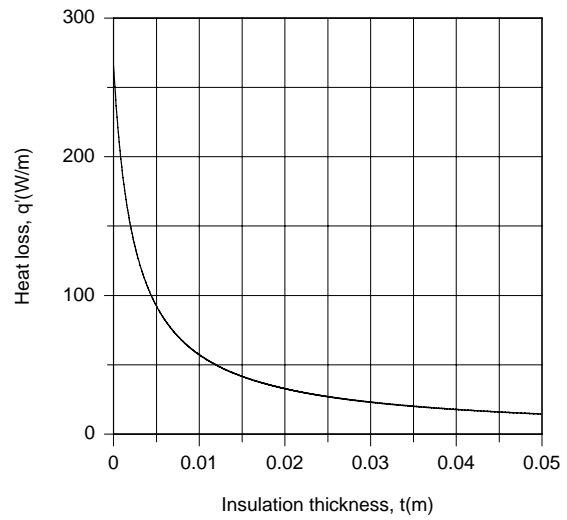
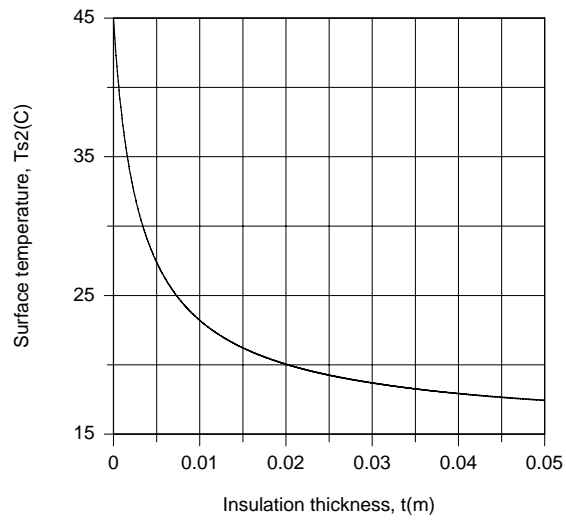

**COMMENTS:** Contrasting the heat rates of part (a) with those predicted in Comment 1 of Example 9.3, it is evident that radiation is significant and increases the total heat loss from 57.6 W/m to 74.8 W/m. As shown in part (b), reductions in  $T_{s,o}$  and  $q'$  may be effected by increasing the insulation thickness above 0.025 W/m·K, although attendant benefits diminish with increasing  $t$ .

### PROBLEM 9.37

**KNOWN:** Electric heater at bottom of tank of 400mm diameter maintains surface at 70°C with engine oil at 5°C.

**FIND:** Power required to maintain 70°C surface temperature.

**SCHEMATIC:**

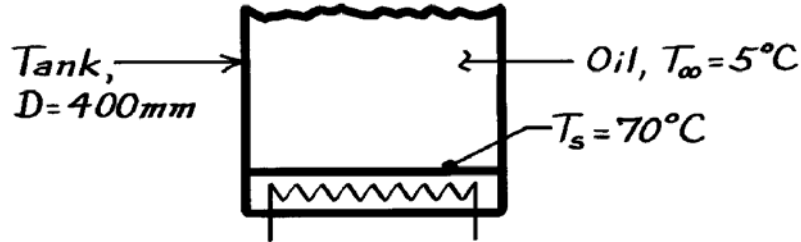

**ASSUMPTIONS:** (1) Oil is quiescent, (2) Quasi-steady state conditions exist.

**PROPERTIES:** Table A-5, Engine Oil ( $T_f = (T_\infty + T_s)/2 = 310\text{K}$ ):  $\nu = 288 \times 10^{-6} \text{ m}^2/\text{s}$ ,  $k = 0.145 \text{ W/m}\cdot\text{K}$ ,  $\alpha = 0.847 \times 10^{-7} \text{ m}^2/\text{s}$ ,  $\beta = 0.70 \times 10^{-3} \text{ K}^{-1}$ .

**ANALYSIS:** The heat rate from the bottom heater surface to the oil is

$$q = \bar{h}A_s(T_s - T_\infty)$$

where  $\bar{h}$  is estimated from the appropriate correlation depending upon the Rayleigh number  $Ra_L$ , from Eq. 9.25, using the characteristic length,  $L$ , from Eq. 9.29,

$$L = \frac{A_s}{P} = \frac{\pi D^2/4}{\pi D} = \frac{D}{4} = \frac{0.4\text{m}}{4} = 0.1\text{m}.$$

The Rayleigh number is

$$Ra_L = \frac{g\beta(T_s - T_\infty)L^3}{\nu\alpha}$$

$$Ra_L = \frac{9.8\text{m/s}^2 \times 0.70 \times 10^{-3} \text{ K}^{-1} (70 - 5)\text{K} \times 0.1^3 \text{ m}^3}{288 \times 10^{-6} \text{ m}^2/\text{s} \times 0.847 \times 10^{-7} \text{ m}^2/\text{s}} = 1.828 \times 10^7.$$

The appropriate correlation is Eq. 9.31 giving

$$\overline{Nu}_L = \frac{\bar{h}L}{k} = 0.15 Ra_L^{1/3} = 0.15 (1.828 \times 10^7)^{1/3} = 39.5$$

$$\bar{h} = \frac{k}{L} \overline{Nu}_L = \frac{0.145 \text{ W/m}\cdot\text{K}}{0.1\text{m}} \times 39.5 = 57.3 \text{ W/m}^2 \cdot \text{K}.$$

The heat rate is then

$$q = 57.3 \text{ W/m}^2 \cdot \text{K} (\pi/4) (0.4\text{m})^2 (70 - 5)\text{K} = 468 \text{ W}.$$

<

**COMMENTS:** Note that the characteristic length is  $D/4$  and not  $D$ ; however,  $A_s$  is based upon  $D$ . Recognize that if the oil is being continuously heated by the plate,  $T_\infty$  could change. Hence, here we have analyzed a quasi-steady state condition.

### PROBLEM 9.38

**KNOWN:** Horizontal, straight fin fabricated from plain carbon steel with thickness 6 mm and length 100 mm; base temperature is 150°C and air temperature is 25°C.

**FIND:** (a) Fin heat rate per unit width,  $q'_f$ , assuming an average fin surface temperature  $\bar{T}_s = 125^\circ\text{C}$  for estimating free convection and linearized radiation coefficient; how sensitive is  $q'_f$  to the assumed value for  $\bar{T}_s$ ?; (b) Compute and plot the heat rate,  $q'_f$  as a function of emissivity  $0.05 \leq \epsilon \leq 0.95$ ; show also the fraction of the total heat rate due to radiation exchange.

**SCHEMATIC:**

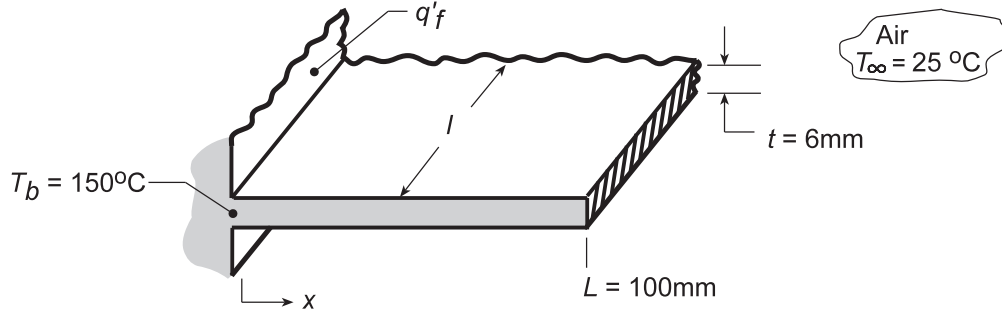

**ASSUMPTIONS:** (1) Air is quiescent medium, (2) Surface radiation effects are negligible, (3) One dimensional conduction in fin, (4) Characteristic length,  $L_c = A_s/P = \ell L(2\ell + 2L) \approx L/2$ .

**PROPERTIES:** Plain carbon steel, Given ( $\bar{T}_{\text{fin}} \approx 125^\circ\text{C} \approx 400\text{K}$ ):  $k = 57\text{ W/m}\cdot\text{K}$ ,  $\epsilon = 0.5$ ; Table A-

4, Air ( $T_f = (\bar{T}_{\text{fin}} + T_\infty)/2 = (125 + 25)^\circ\text{C}/2 \approx 350\text{K}$ , 1 atm):  $\nu = 20.92 \times 10^{-6}\text{ m}^2/\text{s}$ ,  $\alpha = 29.9 \times 10^{-6}\text{ m}^2/\text{s}$ ,  $k = 0.030\text{ W/m}\cdot\text{K}$ ,  $\text{Pr} = 0.70$ ,  $\beta = 1/T_f$ .

**ANALYSIS:** (a) We estimate  $\bar{h}$  as the average of the values for a heated plate facing upward and a heated plate facing downward. See Table 9.2, Case 3(a) and (b). Begin by evaluating the Rayleigh number, using Eq. 9.29 for  $L_c$ .

$$\text{Ra}_L = \frac{g\beta(\bar{T}_{\text{fin}} - T_\infty)L_c^3}{\nu\alpha} = \frac{9.8\text{ m/s}^2(1/350\text{K})(125 - 25)\text{K} \times (0.1\text{ m}/2)^3}{20.92 \times 10^{-6}\text{ m}^2/\text{s} \times 29.9 \times 10^{-6}\text{ m}^2/\text{s}} = 5.595 \times 10^5$$

An average fin temperature of  $\bar{T}_{\text{fin}} \approx 125^\circ\text{C}$  has been assumed in evaluating properties and  $\text{Ra}_L$ . According to Table 9.2, Eqs. 9.30 and 9.32 are appropriate. For the *upper* fin surface, Eq. 9.30,

$$\overline{\text{Nu}}_L = \bar{h}L_c/k = 0.54\text{Ra}_L^{1/4} = 0.54(5.595 \times 10^5)^{1/4} = 14.77$$

$$\bar{h}_{\text{upper}} = \overline{\text{Nu}}_L k/L_c = 14.77 \times 0.030\text{ W/m}\cdot\text{K}/0.05\text{ m} = 8.86\text{ W/m}^2\cdot\text{K}.$$

For the *lower* fin surface, Eq. 9.32,

$$\overline{\text{Nu}}_L = \bar{h}L/k = 0.52\text{Ra}_L^{1/5} = 0.52(5.595 \times 10^5)^{1/5} = 7.34$$

$$\bar{h}_{\text{lower}} = \overline{\text{Nu}}_L k/L = 7.34 \times 0.030\text{ W/m}\cdot\text{K}/0.05\text{ m} = 4.40\text{ W/m}^2\cdot\text{K}.$$

The linearized radiation coefficient follows from Eq. 1.9

$$\bar{h}_r = \epsilon\sigma(\bar{T}_{\text{fin}} + T_{\text{sur}})(\bar{T}_{\text{fin}}^2 + T_{\text{sur}}^2)$$

$$\bar{h}_r = 0.5 \times 5.67 \times 10^{-8}\text{ W/m}^2\cdot\text{K}^4(398 + 298)(398^2 + 298^2)\text{K}^3 = 4.88\text{ W/m}^2\cdot\text{K}$$

Continued ...

**PROBLEM 9.38 (Cont.)**

Hence, the average heat transfer coefficient for the fin is

$$\bar{h} = (\bar{h}_{\text{upper}} + \bar{h}_{\text{lower}})/2 + \bar{h}_r = [(8.86 + 4.40)/2 + 4.88] \text{ W/m}^2 \cdot \text{K} = 11.51 \text{ W/m}^2 \cdot \text{K}$$

Assuming the fin tip is adiabatic, from Eq. 3.81,

$$q_f = M \tanh(mL)$$

$$M = (\bar{h} P k A_c)^{1/2} \theta_b = \left( 11.51 \text{ W/m}^2 \cdot \text{K} \times 2\ell \times 57 \text{ W/m} \cdot \text{K} \left( 6 \times 10^{-3} \text{ m} \times \ell \right) \right)^{1/2} (150 - 25) \text{ K} = 350.7 \text{ W}$$

$$m = (\bar{h} P / k A_c)^{1/2} = \left( 11.51 \text{ W/m}^2 \cdot \text{K} \times 2\ell / 57 \text{ W/m} \cdot \text{K} \left( 6 \times 10^{-3} \text{ m} \times \ell \right) \right)^{1/2} = 8.20 \text{ m}^{-1}$$

$$mL = 8.20 \text{ m}^{-1} \times 0.1 \text{ m} = 0.820$$

$$q'_f = q_f / \ell = 350.7 \text{ W/m} \times \tanh(0.820) = 237 \text{ W/m} .$$

<

To determine how sensitive the estimate for  $\bar{h}$  is to the choice of the average fin surface temperature, the foregoing calculations were repeated using the *IHT Correlations Tool and Extended Surface Model* and the results are tabulated below; coefficients have units  $\text{W/m}^2 \cdot \text{K}$ ,

$\bar{T}_{\text{fin}} (\text{ }^\circ\text{C})$	125	135	145
$\bar{h}_{\text{lower}}$	4.40	4.49	4.56
$\bar{h}_{\text{upper}}$	8.87	9.05	9.21
$\bar{h}_r$	4.88	5.11	5.35
$\bar{h}$	11.5	11.9	12.2
$q' (\text{W/m})$	237	243	249

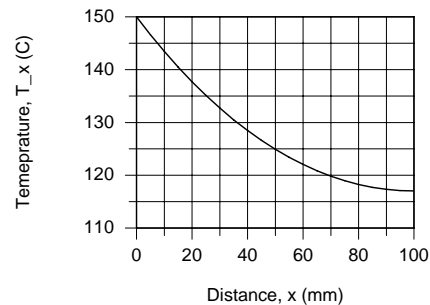

The temperature distribution for the  $\bar{T}_{\text{fin}} = 125^\circ\text{C}$  case is shown above. With  $\bar{T}_{\text{fin}} = 145^\circ\text{C}$ , the tip temperature is about  $2^\circ\text{C}$  higher. It appears that  $\bar{T}_{\text{fin}} = 125^\circ\text{C}$  was a reasonable choice. Note  $\bar{T}_{\text{fin}}$  is the value at the mid length.

(b) Using the IHT code developed for part (a), the fin heat rate,  $q_f$ , was plotted as a function of the emissivity. In this analysis, the convection and radiation coefficients were evaluated for an average fin temperature  $\bar{T}_{\text{fin}}$  evaluated at  $L/2$ . On the same plot we have also shown  $\text{rad} (\%) = (\bar{h}_r / \bar{h}) \times 100$ , which is the portion of the total heat rate due to radiation exchange.

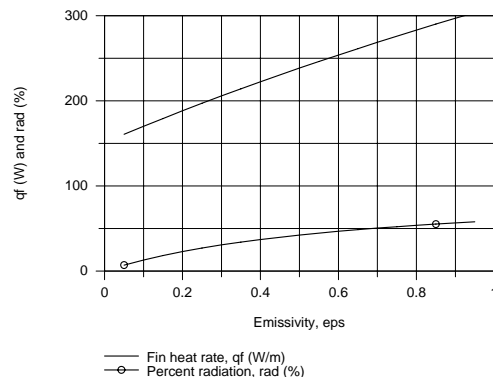

### PROBLEM 9.39

**KNOWN:** Width and thickness of sample material. Rate of heat dissipation at bottom surface of sample and temperatures of top and bottom surfaces. Temperature of quiescent air and surroundings.

**FIND:** Thermal conductivity and emissivity of the sample.

**SCHEMATIC:**

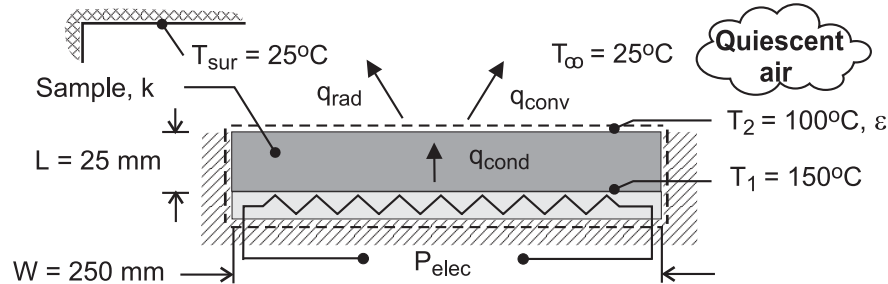

**ASSUMPTIONS:** (1) Steady-state, (2) One-dimensional conduction in sample, (3) Quiescent air, (4) Sample is small relative to surroundings, (5) All of the heater power dissipation is transferred through the sample, (6) Constant properties.

**PROPERTIES:** Table A-4, air ( $T_f = 335.5\text{K}$ ):  $\nu = 19.5 \times 10^{-6} \text{ m}^2/\text{s}$ ,  $k = 0.0289 \text{ W/m}\cdot\text{K}$ ,  $\alpha = 27.8 \times 10^{-6} \text{ m}^2/\text{s}$ ,  $\text{Pr} = 0.703$ ,  $\beta = 0.00298 \text{ K}^{-1}$ .

**ANALYSIS:** The thermal conductivity is readily obtained by applying Fourier's law to the sample.

Hence, with  $q = P_{\text{elec}}$ ,

$$k = \frac{P_{\text{elec}} / W^2}{(T_1 - T_2) / L} = \frac{70 \text{ W} / (0.250\text{m})^2}{50^\circ\text{C} / 0.025\text{m}} = 0.560 \text{ W} / \text{m}\cdot\text{K} \quad <$$

The surface emissivity may be obtained by applying an energy balance to a control surface about the sample, in which case

$$P_{\text{elec}} = q_{\text{conv}} + q_{\text{rad}} = \left[ \bar{h}(T_2 - T_\infty) + \varepsilon\sigma(T_2^4 - T_{\text{sur}}^4) \right] W^2$$

$$\varepsilon = \frac{\left( P_{\text{elec}} / W^2 \right) - \bar{h}(T_2 - T_\infty)}{\sigma(T_2^4 - T_{\text{sur}}^4)}$$

With  $L = A_s/P = W^2/4W = W/4 = 0.0625\text{m}$ ,  $\text{Ra}_L = g\beta(T_2 - T_\infty)L^3/\nu\alpha = 9.86 \times 10^5$  and Eq. 9.30 yields

$$\bar{h} = \frac{\overline{\text{Nu}}_L k}{L} = \frac{k}{L} 0.54 \text{Ra}_L^{1/4} = \frac{0.0289 \text{ W} / \text{m}\cdot\text{K}}{0.0625\text{m}} 0.54 \left( 9.86 \times 10^5 \right)^{1/4} = 7.87 \text{ W} / \text{m}^2 \cdot \text{K} \quad <$$

Hence,

$$\varepsilon = \frac{70 \text{ W} / (0.250\text{m})^2 - 7.87 \text{ W} / \text{m}^2 \cdot \text{K} (75^\circ\text{C})}{5.67 \times 10^{-8} \text{ W} / \text{m}^2 \cdot \text{K}^4 \left( 373^4 - 298^4 \right) \text{K}^4} = 0.815 \quad <$$

**COMMENTS:** The uncertainty in the determination of  $\varepsilon$  is strongly influenced by uncertainties associated with using Eq. 9.30. If, for example,  $\bar{h}$  is overestimated by 10%, the actual value of  $\varepsilon$  would be 0.905.

### PROBLEM 9.40

**KNOWN:** Diameter, power dissipation, emissivity and temperature of gage(s). Air temperature (Cases A and B) and temperature of surroundings (Case A).

**FIND:** (a) Convection heat transfer coefficient (Case A), (b) Convection coefficient and temperature of surroundings (Case B).

**SCHEMATIC:**

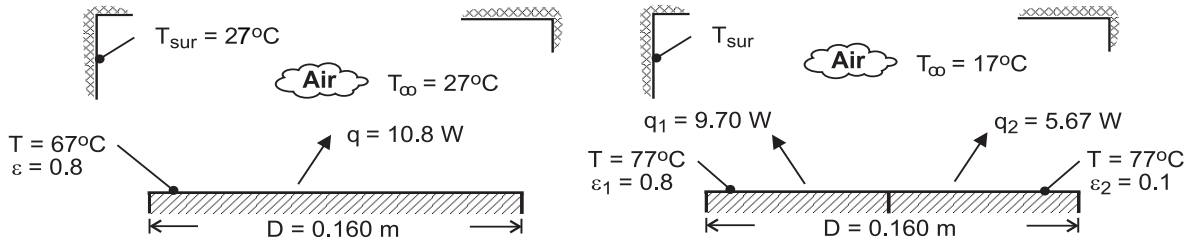

**ASSUMPTIONS:** (1) Steady-state, (2) Quiescent air, (3) Net radiation exchange from surface of gage approximates that of a small surface in large surroundings, (4) All of the electrical power is dissipated by convection and radiation heat transfer from the surface(s) of the gage, (5) Negligible thickness of strip separating semi-circular disks of Part B, (6) Constant properties.

**PROPERTIES:** Table A-4, air ( $T_f = 320\text{K}$ ):  $\nu = 17.9 \times 10^{-6} \text{ m}^2/\text{s}$ ,  $\alpha = 25.5 \times 10^{-6} \text{ m}^2/\text{s}$ ,  $k = 0.0278 \text{ W/m}\cdot\text{K}$ ,  $\text{Pr} = 0.704$ ,  $\beta = 0.00313 \text{ K}^{-1}$ .

**ANALYSIS:** (a) With  $q = q_{\text{conv}} + q_{\text{rad}} = P_{\text{elec}}$  and  $A_s = \pi D^2/4 = 0.0201 \text{ m}^2$ ,

$$\bar{h}_{\text{meas}} = \frac{P_{\text{elec}} - \varepsilon \sigma A_s (T^4 - T_{\text{sur}}^4)}{A_s (T - T_{\infty})} = \frac{10.8 \text{ W} - 0.8 \times 5.67 \times 10^{-8} \text{ W/m}^2 \cdot \text{K}^4 \times 0.0201 \text{ m}^2 (340^4 - 300^4) \text{ K}^4}{0.0201 \text{ m}^2 (40 \text{ K})} = 7.46 \text{ W/m}^2 \cdot \text{K} <$$

With  $L = A_s/P = D/4 = 0.04 \text{ m}$  and  $\text{Ra}_L = g\beta(T - T_{\infty})L^3/\nu\alpha = 1.72 \times 10^5$ , Eq. 9.30 yields

$$\bar{h} = \frac{k}{L} 0.54 \text{Ra}_L^{1/4} = \frac{0.0278 \text{ W/m}\cdot\text{K} \times 0.54 (1.72 \times 10^5)^{1/4}}{0.04 \text{ m}} = 7.64 \text{ W/m}^2 \cdot \text{K} <$$

Agreement between the two values of  $\bar{h}$  is well within the uncertainty of the measurements.

(b) Since the semi-circular disks have the same temperature, each is characterized by the same convection coefficient and  $q_{\text{conv},1} = q_{\text{conv},2}$ . Hence, with

$$P_{\text{elec},1} = q_{\text{conv},1} + \varepsilon_1 \sigma (A_s/2) (T^4 - T_{\text{sur}}^4) \quad (1)$$

$$P_{\text{elec},2} = q_{\text{conv},2} + \varepsilon_2 \sigma (A_s/2) (T^4 - T_{\text{sur}}^4) \quad (2)$$

$$T_{\text{sur}} = \left[ T^4 - \frac{P_{\text{elec},1} - P_{\text{elec},2}}{(\varepsilon_1 - \varepsilon_2) \sigma (A_s/2)} \right]^{1/4} = \left[ (350)^4 - \frac{4.03 \text{ W}}{0.7 \times 5.67 \times 10^{-8} \text{ W/m}^2 \cdot \text{K}^4 \times 0.01 \text{ m}^2} \right]^{1/4}$$

$$T_{\text{sur}} = 264 \text{ K} <$$

From Eq. (1), the convection coefficient is then

$$\bar{h}_{\text{meas}} = \frac{P_{\text{elec},1} - \varepsilon_1 \sigma (A_s/2) (T^4 - T_{\text{sur}}^4)}{(A_s/2) (T - T_{\infty})} = \frac{9.70 \text{ W} - 4.60 \text{ W}}{(0.01 \times 60) \text{ m}^2 \cdot \text{K}} = 8.49 \text{ W/m}^2 \cdot \text{K} <$$

With  $\text{Ra}_L = 2.58 \times 10^5$ , Eq. 9.30 yields

$$\bar{h} = \frac{k}{L} 0.54 \text{Ra}_L^{1/4} = \frac{0.0278 \text{ W/m}\cdot\text{K}}{0.04 \text{ m}} 0.54 (2.58 \times 10^5)^{1/4} = 8.46 \text{ W/m}^2 \cdot \text{K} <$$

Again, agreement between the two values of  $\bar{h}$  is well within the experimental uncertainty of the measurements.

**COMMENTS:** Because the semi-circular disks are at the same temperature, the characteristic length corresponds to that of the circular disk,  $L = D/4$ .

### PROBLEM 9.41

**KNOWN:** Horizontal, circular grill of 0.2m diameter with emissivity 0.9 is maintained at a uniform surface temperature of 130°C when ambient air and surroundings are at 24°C.

**FIND:** Electrical power required to maintain grill at prescribed surface temperature.

**SCHEMATIC:**

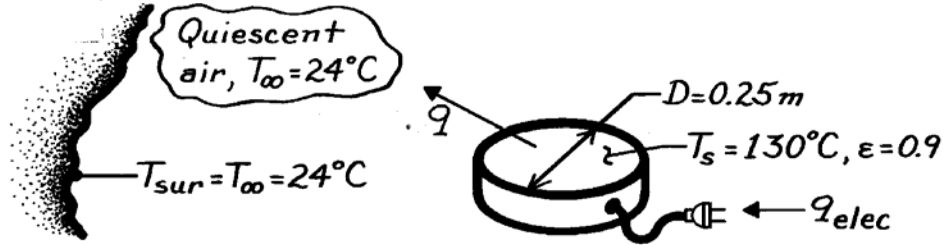

**ASSUMPTIONS:** (1) Room air is quiescent, (2) Surroundings are large compared to grill surface.

**PROPERTIES:** Table A-4, Air ( $T_f = (T_\infty + T_s)/2 = (24 + 130)^\circ\text{C}/2 = 350\text{K}$ , 1 atm):

$$\nu = 20.92 \times 10^{-6} \text{ m}^2/\text{s}, k = 0.030 \text{ W/m}\cdot\text{K}, \alpha = 29.9 \times 10^{-6} \text{ m}^2/\text{s}, \beta = 1/T_f.$$

**ANALYSIS:** The heat loss from the grill is due to free convection with the ambient air and to radiation exchange with the surroundings.

$$q = A_s \left[ \bar{h} (T_s - T_\infty) + \varepsilon \sigma (T_s^4 - T_{\text{sur}}^4) \right] \quad (1)$$

Calculate  $Ra_L$  from Eq. 9.25,

$$Ra_L = g\beta (T_s - T_\infty) L_c^3 / \nu\alpha$$

where for a horizontal disc from Eq. 9.29,  $L_c = A_s/P = (\pi D^2/4)/\pi D = D/4$ . Substituting numerical values, find

$$Ra_L = \frac{9.8 \text{ m/s}^2 (1/350\text{K})(130 - 24)\text{K} (0.25\text{m}/4)^3}{20.92 \times 10^{-6} \text{ m}^2/\text{s} \times 29.9 \times 10^{-6} \text{ m}^2/\text{s}} = 1.158 \times 10^6.$$

Since the grill has a *hot upper surface*, Eq. 9.30 is the appropriate correlation,

$$\overline{Nu}_L = \bar{h}_L L_c / k = 0.54 Ra_L^{1/4} = 0.54 (1.158 \times 10^6)^{1/4} = 17.72$$

$$\bar{h}_L = \overline{Nu}_L k / L_c = 17.72 \times 0.030 \text{ W/m}\cdot\text{K} / (0.25\text{m}/4) = 8.50 \text{ W/m}^2 \cdot \text{K}. \quad (2)$$

Substituting from Eq. (2) for  $\bar{h}$  into Eq. (1), the heat loss or required electrical power,  $q_{\text{elec}}$ , is

$$q = \frac{\pi}{4} (0.25\text{m})^2 \left[ 8.50 \frac{\text{W}}{\text{m}^2 \cdot \text{K}} (130 - 24)\text{K} + 0.9 \times 5.67 \times 10^{-8} \frac{\text{W}}{\text{m}^2 \cdot \text{K}^4} \left( (130 + 273)^4 - (24 + 273)^4 \right) \text{K}^4 \right]$$

$$q = 44.2 \text{ W} + 46.0 \text{ W} = 90.2 \text{ W}. \quad <$$

**COMMENTS:** Note that for this situation, free convection and radiation modes are of equal importance. If the grill were highly polished such that  $\varepsilon \approx 0.1$ , the required power would be reduced by nearly 50%.

## PROBLEM 9.42

**KNOWN:** Power dissipation by a laptop computer CPU. Dimensions and emissivity of the laptop screen assembly. Thickness and thermal conductivity of plastic casing as well as thermal contact resistance between heat spreader and plastic casing. Temperature of the surroundings and of the ambient.

**FIND:** Temperature of the heat spreader and magnitudes of convection, radiation, conduction and contact resistances.

**SCHEMATIC:**

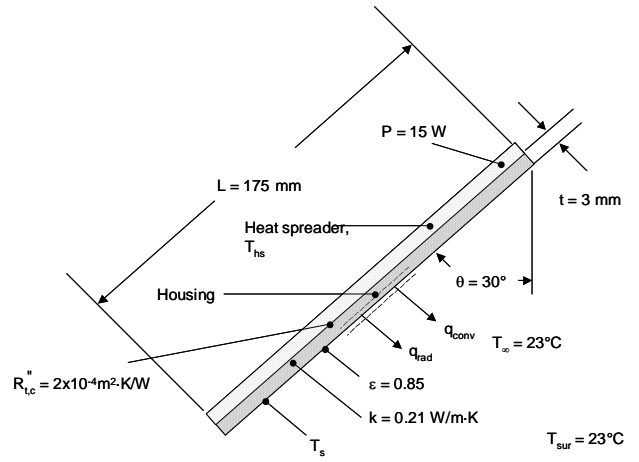

**ASSUMPTIONS:** (1) Constant properties and steady-state conditions, (2) Large surroundings, (3) Isothermal heat spreader, (4) Laptop screen can be treated as a suspended plate.

**PROPERTIES:** Table A.4, air: ( $T_f = 310 \text{ K}$  assumed):  $k = 0.02704 \text{ W/m}\cdot\text{K}$ ,  $\nu = 1.690 \times 10^{-5} \text{ m}^2/\text{s}$ ,  $\alpha = 2.398 \times 10^{-5} \text{ m}^2/\text{s}$ ,  $\text{Pr} = 0.7056$ .

**ANALYSIS:** An energy balance on the control surface shown in the schematic yields

$$P = q_{\text{conv}} + q_{\text{rad}} = Lw \left[ \bar{h}(T_s - T_\infty) + \varepsilon\sigma(T_s^4 - T_{\text{sur}}^4) \right]$$

or

$$15\text{W} = 0.275\text{m} \times 0.175\text{m} \left[ \bar{h}(T_s - 298\text{K}) + 0.85 \times 5.67 \times 10^{-8} \text{W/m}^2 \cdot \text{K}^4 (T_s^4 - (298\text{K})^4) \right] \quad (1)$$

The convection coefficient can be found by using the Churchill and Chu correlation with  $g$  replaced by  $g \cos \theta$ . Hence,

$$\text{Ra}_L = \frac{g(\cos \theta)\beta(T_s - T_\infty)L^3}{\nu \cdot \alpha}$$

Continued...



**PROBLEM 9.42 (Cont.)**

$$Ra_L = \frac{9.8 \text{ m/s}^2 \times \cos 30^\circ \times (1/310 \text{ K}) \times (T_s - 298 \text{ K}) \times (0.175 \text{ m})^3}{1.690 \times 10^{-5} \text{ m}^2/\text{s} \times 2.398 \times 10^{-5} \text{ m}^2/\text{s}} \quad (2)$$

and

$$\bar{h} = \frac{0.02704 \text{ W/m} \cdot \text{K}}{0.175 \text{ m}} \times \left\{ 0.825 + \frac{0.387 \times Ra_L^{1/6}}{\left[ 1 + (0.492/0.7056)^{9/16} \right]^{8/27}} \right\}^2 \quad (3)$$

Simultaneous solution of Equations 1 through 3 yields

$$Ra_L = 1.048 \times 10^7, \bar{Nu}_L = 31.6, \bar{h} = 4.89 \text{ W/m}^2 \cdot \text{K}, T_s = 325.2 \text{ K} = 52.2^\circ \text{C}$$

The temperature of the heat spreader is

$$T_{hs} = T_s + \frac{P}{Lw} \left[ R_{t,c}'' + t/k \right] \text{ or}$$

$$T_{hs} = 52.2^\circ \text{C} + \frac{15 \text{ W}}{0.175 \text{ m} \times 0.275 \text{ m}} \left[ 2 \times 10^{-4} \frac{\text{m}^2 \cdot \text{K}}{\text{W}} + \frac{3 \times 10^{-3} \text{ m}}{0.21 \text{ W/m} \cdot \text{K}} \right] = 56.7^\circ \text{C} \quad <$$

Knowing  $A = Lw = 0.275 \text{ m} \times 0.175 \text{ m} = 4.81 \times 10^{-3} \text{ m}^2$ , the convection resistance is

$$R_{t,conv} = \frac{1}{hA} = \frac{1}{4.89 \text{ W/m}^2 \cdot \text{K} \times 4.81 \times 10^{-3} \text{ m}^2} = 4.30 \text{ K/W} \quad <$$

The radiation resistance, using

$$h_r = \varepsilon \sigma (T_s + T_{sur})(T_s^2 + T_{sur}^2)$$

$$= 0.85 \times 5.67 \times 10^{-8} (\text{W/m}^2 \cdot \text{K}^4) \times (325.2 \text{ K} + 298 \text{ K}) \times (325.2^2 + 298^2) \text{ K}^2 = 5.84 \text{ W/m}^2 \cdot \text{K}$$

is

$$R_{t,rad} = \frac{1}{h_r A} = \frac{1}{5.84 \text{ W/m}^2 \cdot \text{K} \times 4.81 \times 10^{-3} \text{ m}^2} = 3.56 \text{ K/W} \quad <$$

The conduction resistance is

$$R_{t,cond} = \frac{t}{kA} = \frac{3 \times 10^{-3} \text{ m}}{0.21 \text{ W/m} \cdot \text{K} \times 4.81 \times 10^{-3} \text{ m}^2} = 0.30 \text{ K/W} \quad <$$

Continued...

### PROBLEM 9.42 (Cont.)

The contact resistance is

$$R_{t,c} = \frac{R''_{t,c}}{A} = \frac{2 \times 10^{-4} \text{ m}^2 \cdot \text{K/W}}{4.81 \times 10^{-3} \text{ m}^2} = 4.2 \times 10^{-3} \text{ K/W} \quad <$$

**COMMENTS:** (1) The actual film temperature is  $T_f = (23^\circ\text{C} + 52.2^\circ\text{C})/2 = 37.6^\circ\text{C} = 310.6 \text{ K}$ . The assumed value of the film temperature is excellent. (2) The convection and radiation resistances are large. The radiation resistance cannot be reduced significantly since the emissivity of the plastic is high. The convection resistance would vary as the laptop screen angle is changed.

### PROBLEM 9.43

**KNOWN:** Material properties, inner surface temperature and dimensions of roof of refrigerated truck compartment. Solar irradiation and ambient temperature.

**FIND:** Outer surface temperature of roof and rate of heat transfer to compartment.

**SCHEMATIC:**

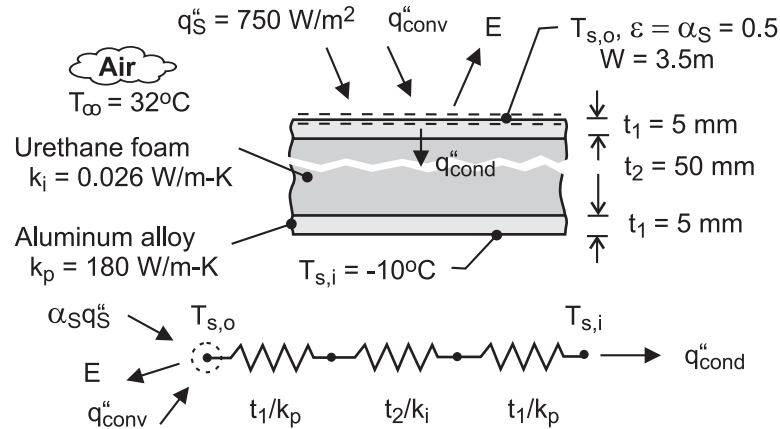

**ASSUMPTIONS:** (1) Negligible irradiation from the sky, (2)  $T_{s,o} > T_{\infty}$  (hot surface facing upward) and  $Ra_L > 10^7$ , (3) Constant properties.

**PROPERTIES:** Table A-4, air ( $p = 1 \text{ atm}$ ,  $T_f \approx 310 \text{ K}$ ):  $\nu = 16.9 \times 10^{-6} \text{ m}^2/\text{s}$ ,  $k = 0.0270 \text{ W/m}\cdot\text{K}$ ,  $Pr = 0.706$ ,  $\alpha = \nu/Pr = 23.9 \times 10^{-6} \text{ m}^2/\text{s}$ ,  $\beta = 0.00323 \text{ K}^{-1}$ .

**ANALYSIS:** From an energy balance for the outer surface,

$$\alpha_S G_S - q_{\text{conv}}'' - E = q_{\text{cond}}'' = \frac{T_{s,o} - T_{s,i}}{R_{\text{tot}}''}$$

$$\alpha_S G_S - \bar{h}(T_{s,o} - T_{\infty}) - \varepsilon \sigma T_{s,o}^4 = \frac{T_{s,o} - T_{s,i}}{2R_p'' + R_i''}$$

where  $R_p'' = (t_1/k_p) = 2.78 \times 10^{-5} \text{ m}^2 \cdot \text{K}/\text{W}$  and  $R_i'' = (t_2/k_i) = 1.923 \text{ m}^2 \cdot \text{K}/\text{W}$ . For a hot surface facing upward and  $Ra_L = g\beta(T_{s,o} - T_{\infty})L^3/\alpha\nu > 10^7$ ,  $\bar{h}$  is obtained from Eq. 9.31. Hence, with cancellation of  $L$ ,

$$\begin{aligned} \bar{h} = \frac{k}{L} 0.15 Ra_L^{1/3} &= 0.15 \times 0.0270 \text{ W/m}\cdot\text{K} \left( \frac{9.8 \text{ m/s}^2 \times 0.00323 \text{ K}^{-1}}{16.9 \times 23.9 \times 10^{-12} \text{ m}^4/\text{s}^2} \right)^{1/3} (T_{s,o} - T_{\infty})^{1/3} \\ &= 1.73 \text{ W/m}^2 \cdot \text{K}^{4/3} (T_{s,o} - 305 \text{ K})^{1/3} \end{aligned}$$

Hence,

$$0.5 \left( 750 \text{ W/m}^2 \cdot \text{K} \right) - 1.73 \text{ W/m}^2 \cdot \text{K}^{4/3} (T_{s,o} - 305)^{4/3} - 0.5 \times 5.67 \times 10^{-8} \text{ W/m}^2 \cdot \text{K}^4 T_{s,o}^4 = \frac{T_{s,o} - 263 \text{ K}}{(5.56 \times 10^{-5} + 1.923) \text{ m}^2 \cdot \text{K}/\text{W}}$$

Solving, we obtain  $T_{s,o} = 318.3 \text{ K} = 45.3^\circ\text{C}$  <

Hence, the heat load is  $q = (W \cdot L_t) q_{\text{cond}}'' = (3.5 \text{ m} \times 10 \text{ m}) \frac{(45.3 + 10)^\circ\text{C}}{1.923 \text{ m}^2 \cdot \text{K}/\text{W}} = 1007 \text{ W}$  <

**COMMENTS:** (1) The thermal resistance of the aluminum panels is negligible compared to that of the insulation. (2) The value of the convection coefficient is  $\bar{h} = 1.73(T_{s,o} - T_{\infty})^{1/3} = 4.10 \text{ W/m}^2 \cdot \text{K}$ .

## PROBLEM 9.44

**KNOWN:** Inner surface temperature and composition of a furnace roof. Emissivity of outer surface and temperature of surroundings.

**FIND:** (a) Heat loss through roof with no insulation, (b) Heat loss with insulation and inner surface temperature of insulation, and (c) Thickness of fire clay brick which would reduce the insulation temperature,  $T_{ins,i}$  to 1350 K.

**SCHEMATIC:**

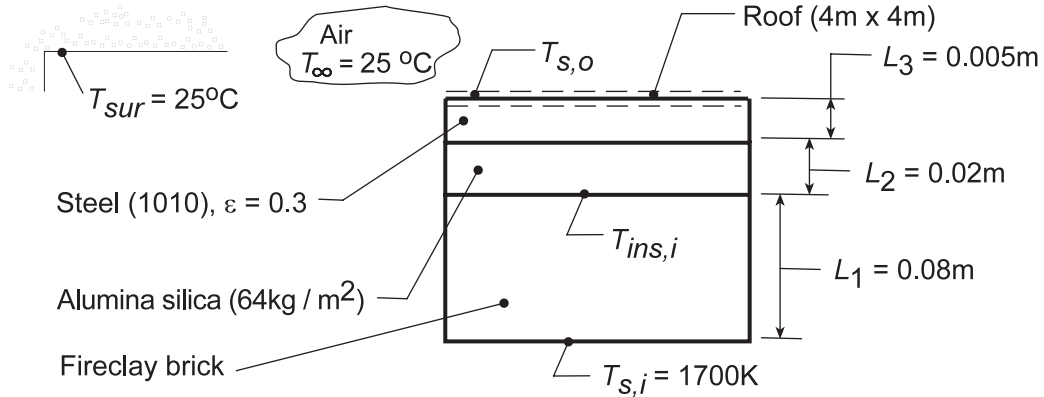

**ASSUMPTIONS:** (1) Steady-state conditions, (2) One-dimensional conduction through the composite wall, (3) Negligible contact resistance, (4) Constant properties.

**PROPERTIES:** Table A-4, Air ( $T_f \approx 400$  K, 1 atm):  $k = 0.0338$  W/m·K,  $\nu = 26.4 \times 10^{-6}$  m<sup>2</sup>/s,  $\alpha = 38.3 \times 10^{-6}$  m<sup>2</sup>/s,  $Pr = 0.69$ ,  $\beta = (400 \text{ K})^{-1} = 0.0025 \text{ K}^{-1}$ ; Table A-1, Steel 1010 (600 K):  $k = 48.8$  W/m·K; Table A-3 Alumina-Silica blanket (64 kg/m<sup>3</sup>, 750 K):  $k = 0.125$  W/m·K; Table A-3, Fire clay brick (1478 K):  $k = 1.8$  W/m·K.

**ANALYSIS:** (a) Without the insulation, the thermal circuit is

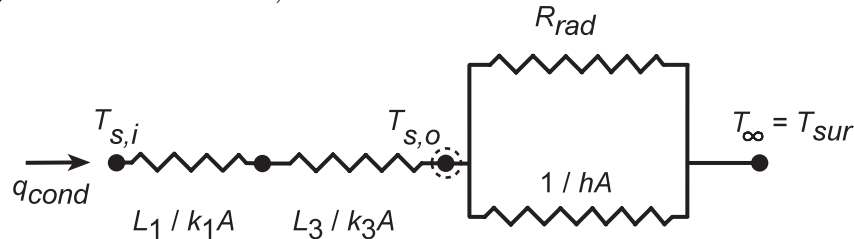

Performing an energy balance at the outer surface, it follows that

$$q_{\text{cond}} = q_{\text{conv}} + q_{\text{rad}} \quad \frac{T_{s,i} - T_{s,o}}{L_1/k_1A + L_3/k_3A} = hA(T_{s,o} - T_{\infty}) + \varepsilon\sigma A(T_{s,o}^4 - T_{\text{sur}}^4) \quad (1,2)$$

where the radiation term is evaluated from Eq. 1.7. The characteristic length associated with free convection from the roof is, from Eq. 9.29  $L = A_s/P = 16\text{m}^2/16\text{m} = 1\text{m}$ . From Eq. 9.25, with an assumed value for the film temperature,  $T_f = 400$  K,

$$Ra_L = \frac{g\beta(T_{s,o} - T_{\infty})L^3}{\nu\alpha} = \frac{9.8\text{m/s}^2(0.0025\text{K}^{-1})(T_{s,o} - T_{\infty})(1\text{m})^3}{26.4 \times 10^{-6}\text{m}^2/\text{s} \times 38.3 \times 10^{-6}\text{m}^2/\text{s}} = 2.42 \times 10^7 (T_{s,o} - T_{\infty})$$

Hence, from Eq. 9.31

$$h = \frac{k}{L} 0.15 Ra_L^{1/3} = \frac{0.0338\text{W/m}\cdot\text{K}}{1\text{m}} 0.15 (2.42 \times 10^7)^{1/3} (T_{s,o} - T_{\infty})^{1/3} = 1.47 (T_{s,o} - T_{\infty})^{1/3} \text{W/m}^2 \cdot \text{K}. (3)$$

Continued...

### PROBLEM 9.44 (Cont.)

The energy balance can now be written

$$\frac{(1700 - T_{s,o})K}{(0.08\text{m}/1.8\text{ W/m}\cdot\text{K} + 0.005\text{m}/48.8\text{ W/m}\cdot\text{K})} = 1.47(T_{s,o} - 298\text{ K})^{4/3} + 0.3 \times 5.67 \times 10^{-8} \text{ W/m}^2 \cdot \text{K}^4 [T_{s,o}^4 - (298\text{ K})^4]$$

and from iteration, find  $T_{s,o} \approx 895\text{ K}$ . Hence,

$$q = 16\text{m}^2 \left\{ 1.47(895 - 298)^{4/3} \text{ W/m}^2 + 0.3 \times 5.67 \times 10^{-8} \text{ W/m}^2 \cdot \text{K}^4 [(895\text{ K})^4 - (298\text{ K})^4] \right\}$$

$$q = 16\text{m}^2 \{ 7,389 + 10,780 \} \text{ W/m}^2 = 2.91 \times 10^5 \text{ W} . \quad <$$

(b) *With the insulation*, an additional conduction resistance is provided and the energy balance at the outer surface becomes

$$\frac{T_{s,i} - T_{s,o}}{L_1/k_1A + L_2/k_2A + L_3/k_3A} = hA(T_{s,o} - T_\infty) + \varepsilon\sigma A(T_{s,o}^4 - T_{\text{sur}}^4) \quad (4)$$

$$\frac{(1700 - T_{s,o})K}{(0.08\text{m}/1.8 + 0.02/0.125 + 0.005/48.8)\text{m}^2 \cdot \text{K/W}} = 1.47(T_{s,o} - 298\text{ K})^{4/3} + 0.3 \times 5.67 \times 10^{-8} \text{ W/m}^2 \cdot \text{K}^4 [T_{s,o}^4 - (298\text{ K})^4]$$

From an iterative solution, it follows that  $T_{s,o} \approx 610\text{ K}$ . Hence,

$$q = 16\text{m}^2 \left\{ 1.47(610 - 298)^{4/3} \text{ W/m}^2 + 0.3 \times 5.67 \times 10^{-8} \text{ W/m}^2 \cdot \text{K}^4 [(610\text{ K})^4 - (298\text{ K})^4] \right\}$$

$$q = 16\text{m}^2 \{ 3111 + 2221 \} \text{ W/m}^2 = 8.53 \times 10^4 \text{ W} . \quad <$$

The insulation inner surface temperature is given by

$$q = \frac{T_{s,i} - T_{\text{ins},i}}{L_1/k_1A} .$$

Hence

$$T_{\text{ins},i} = -q \frac{L_1}{k_1A} + T_{s,i} = -8.53 \times 10^4 \text{ W} \frac{0.08\text{ m}}{1.8\text{ W/m}\cdot\text{K} \times 16\text{m}^2} + 1700\text{ K} = 1463\text{ K} . \quad <$$

(c) To determine the required thickness  $L_1$  of the fire clay brick to reduce  $T_{\text{ins},i} = 1350\text{ K}$ , we keyed Eq. (4) into the IHT Workspace and found

$$L_1 = 0.13\text{ m} . \quad <$$

**COMMENTS:** (1) The accuracy of the calculations could be improved by re-evaluating thermophysical properties at more appropriate temperatures.

(2) Convection and radiation heat losses from the roof are comparable. The relative contribution of radiation increases with increasing  $T_{s,o}$ , and hence decreases with the addition of insulation.

(3) Note that with the insulation,  $T_{\text{ins},i} = 1463\text{ K}$  exceeds the melting point of aluminum (933 K). Hence, molten aluminum, which can seep through the refractory, would penetrate, and thereby degrade the insulation, under the specified conditions.

### PROBLEM 9.45

**KNOWN:** Diameter, thickness, emissivity and initial temperature of silicon wafer. Temperature of air and surrounding.

**FIND:** (a) Initial cooling rate, (b) Time required to achieve prescribed final temperature.

**SCHEMATIC:**

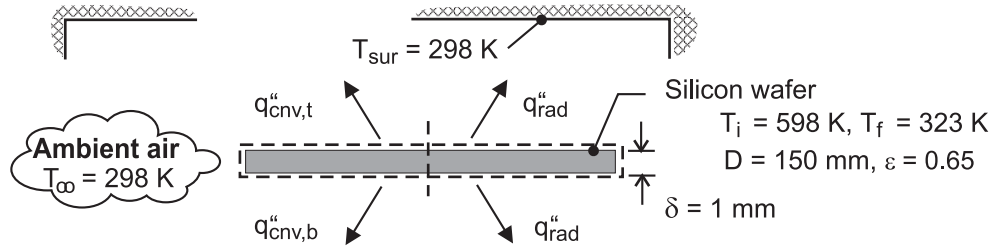

**ASSUMPTIONS:** (1) Negligible heat transfer from side of wafer, (2) Large surroundings, (3) Wafer may be treated as a lumped capacitance, (4) Constant properties, (5) Quiescent air.

**PROPERTIES:** Table A-1, Silicon ( $\bar{T} = 187^\circ\text{C} = 460\text{K}$ ):  $\rho = 2330 \text{ kg/m}^3$ ,  $c_p = 813 \text{ J/kg}\cdot\text{K}$ ,  $k = 87.8 \text{ W/m}\cdot\text{K}$ . Table A-4, Air ( $T_{f,i} = 175^\circ\text{C} = 448\text{K}$ ):  $\nu = 32.15 \times 10^{-6} \text{ m}^2/\text{s}$ ,  $k = 0.0372 \text{ W/m}\cdot\text{K}$ ,  $\alpha = 46.8 \times 10^{-6} \text{ m}^2/\text{s}$ ,  $\text{Pr} = 0.686$ ,  $\beta = 0.00223 \text{ K}^{-1}$ .

**SOLUTION:** (a) Heat transfer is by natural convection and net radiation exchange from top and bottom surfaces. Hence, with  $A_s = \pi D^2/4 = 0.0177 \text{ m}^2$ ,

$$q = A_s \left[ (\bar{h}_t + \bar{h}_b)(T_i - T_\infty) + 2\epsilon\sigma(T_i^4 - T_{\text{sur}}^4) \right]$$

where the radiation flux is obtained from Eq. 1.7, and with  $L = A_s/P = 0.0375\text{m}$  and  $\text{Ra}_L = g\beta(T_i - T_\infty)L^3/\alpha\nu = 2.30 \times 10^5$ , the convection coefficients are obtained from Eqs. 9.30 and 9.32. Hence,

$$\bar{h}_t = \frac{k}{L} \left( 0.54 \text{Ra}_L^{1/4} \right) = \frac{0.0372 \text{ W/m}\cdot\text{K} \times 11.8}{0.0375\text{m}} = 11.7 \text{ W/m}^2\cdot\text{K}$$

$$\bar{h}_b = \frac{k}{L} \left( 0.52 \text{Ra}_L^{1/5} \right) = \frac{0.0372 \text{ W/m}\cdot\text{K} \times 6.14}{0.0375\text{m}} = 6.1 \text{ W/m}^2\cdot\text{K}$$

$$q = 0.0177 \text{ m}^2 \left[ (11.7 + 6.1) \text{ W/m}^2\cdot\text{K} (300\text{K}) + 2 \times 0.65 \times 5.67 \times 10^{-8} \text{ W/m}^2\cdot\text{K}^4 (598^4 - 298^4) \text{ K}^4 \right]$$

$$q = 0.0177 \text{ m}^2 \left[ (5350 + 8845) \text{ W/m}^2 \right] = 251 \text{ W} \quad <$$

(b) From the generalized lumped capacitance model, Eq. 5.15,

$$\rho c A_s \delta \frac{dT}{dt} = - \left[ (\bar{h}_t + \bar{h}_b)(T - T_\infty) + 2\epsilon\sigma(T^4 - T_{\text{sur}}^4) \right] A_s$$

$$\int_{T_i}^T dT = - \int_0^t \left[ \frac{(\bar{h}_t + \bar{h}_b)(T - T_\infty) + 2\epsilon\sigma(T^4 - T_{\text{sur}}^4)}{\rho c \delta} \right] dt$$

Continued .....

**PROBLEM 9.45 (Cont.)**

Using the DER function of IHT to perform the integration, thereby accounting for variations in  $\bar{h}_t$  and  $\bar{h}_b$  with T, the time  $t_f$  to reach a wafer temperature of 50°C is found to be

$$t_f (T = 323 \text{ K}) = 179 \text{ s}$$

<

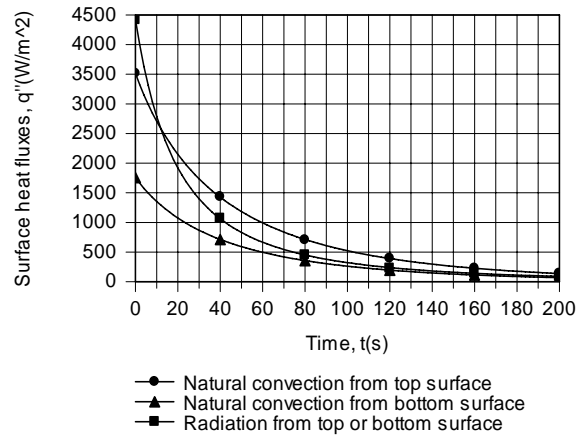
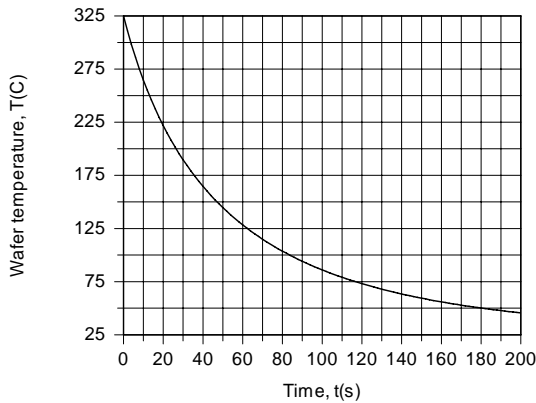

As shown above, the rate at which the wafer temperature decays with increasing time decreases due to reductions in the convection and radiation heat fluxes. Initially, the surface radiative flux (top or bottom) exceeds the heat flux due to natural convection from the top surface, which is twice the flux due to natural convection from the bottom surface. However, because  $q''_{rad}$  and  $q''_{cnv}$  decay approximately as  $T^4$  and  $T^{5/4}$ , respectively, the reduction in  $q''_{rad}$  with decreasing T is more pronounced, and at  $t = 181\text{s}$ ,  $q''_{rad}$  is well below  $q''_{cnv,t}$  and only slightly larger than  $q''_{cnv,b}$ .

**COMMENTS:** With  $\bar{h}_{r,i} = \varepsilon\sigma(T_i + T_{sur})(T_i^2 + T_{sur}^2) = 14.7 \text{ W/m}^2 \cdot \text{K}$ , the largest cumulative coefficient of  $\bar{h}_{tot} = \bar{h}_{r,i} + \bar{h}_{t,i} = 26.4 \text{ W/m}^2 \cdot \text{K}$  corresponds to the top surface. If this coefficient is used to estimate a Biot number, it follows that  $Bi = \bar{h}_{tot}(\delta/2)/k = 1.5 \times 10^{-4} \ll 1$  and the lumped capacitance approximation is excellent.

## PROBLEM 9.46

**KNOWN:** Pyrex tile, initially at a uniform temperature  $T_i = 140^\circ\text{C}$ , experiences cooling by convection with ambient air and radiation exchange with surroundings.

**FIND:** (a) Time required for tile to reach the safe-to-touch temperature of  $T_f = 40^\circ\text{C}$  with free convection and radiation exchange; use  $\bar{T} = (T_i + T_f)/2$  to estimate the average free convection and linearized radiation coefficients; comment on how sensitive result is to this estimate, and (b) Time-to-cool if ambient air is blown in parallel flow over the tile with a velocity of 10 m/s.

**SCHEMATIC:**

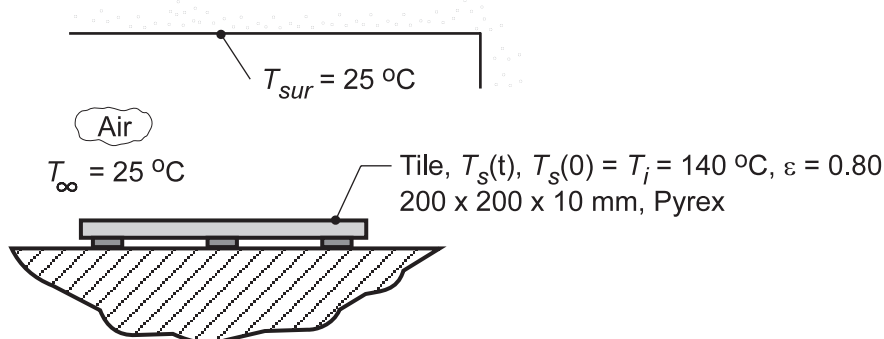

**ASSUMPTIONS:** (1) Tile behaves as spacewise isothermal object, (2) Backside of tile is perfectly insulated, (3) Surroundings are large compared to the tile, (4) For forced convection situation, part (b), assume flow is fully turbulent.

**PROPERTIES:** Table A.3, Pyrex (300 K):  $\rho = 2225 \text{ kg/m}^3$ ,  $c_p = 835 \text{ J/kg}\cdot\text{K}$ ,  $k = 1.4 \text{ W/m}\cdot\text{K}$ ,  $\varepsilon = 0.80$  (given); Table A.4, Air ( $T_f = (\bar{T}_s + T_\infty)/2 = 330.5 \text{ K}$ , 1 atm):  $\nu = 18.96 \times 10^{-6} \text{ m}^2/\text{s}$ ,  $k = 0.0286 \text{ W/m}\cdot\text{K}$ ,  $\alpha = 27.01 \times 10^{-6} \text{ m}^2/\text{s}$ ,  $\text{Pr} = 0.7027$ ,  $\beta = 1/T_f$ .

**ANALYSIS:** (a) For the lumped capacitance system with a constant coefficient, from Eq. 5.6,

$$\frac{T_s(t) - T_\infty}{T_i - T_\infty} = \exp\left[-\left(\frac{\bar{h}A_s}{\rho Vc}\right)t\right] \quad (1)$$

where  $\bar{h}$  is the combined coefficient for the convection and radiation processes,

$$\bar{h} = \bar{h}_{\text{cv}} + \bar{h}_{\text{rad}} \quad (2)$$

$$\text{and } A_s = L^2 \quad V = L^2d \quad (3,4)$$

The linearized radiation coefficient based upon the average temperature,  $\bar{T}_s$ , is

$$\bar{T}_s = (T_i + T_f)/2 = (140 + 40)^\circ\text{C}/2 = 90^\circ\text{C} = 363 \text{ K} \quad (5)$$

$$\bar{h}_{\text{rad}} = \varepsilon\sigma(\bar{T}_s + T_{\text{sur}})(\bar{T}_s^2 + T_{\text{sur}}^2) \quad (6)$$

$$\bar{h}_{\text{rad}} = 0.8 \times 5.67 \times 10^{-8} \text{ W/m}^2 \cdot \text{K}^4 (363 + 298)(363^2 + 298^2) \text{ K}^3 = 6.61 \text{ W/m}^2 \cdot \text{K}$$

The free convection coefficient can be estimated from the correlation for the flat plate, Eq. 9.30, with

$$\text{Ra}_L = \frac{g\beta\Delta TL^3}{\nu\alpha} \quad L = A_s/P = L^2/4L = 0.25L \quad (7,8)$$

Continued...



**PROBLEM 9.46 (Cont.)**

$$Ra_L = \frac{9.8 \text{ m/s}^2 (1/330 \text{ K})(363 - 298) \text{ K} (0.25 \times 0.200 \text{ m})^3}{18.96 \times 10^{-6} \text{ m}^2/\text{s} \times 27.01 \times 10^{-6} \text{ m}^2/\text{s}} = 4.712 \times 10^5$$

$$\overline{Nu}_L = 0.54 Ra_L^{1/4} = 0.54 (4.712 \times 10^5)^{1/4} = 14.18$$

$$\overline{h}_{cv} = \overline{Nu}_L k/L = 14.18 \times 0.0286 \text{ W/m} \cdot \text{K} / 0.25 \times 0.200 \text{ m} = 8.09 \text{ W/m}^2 \cdot \text{K}$$

From Eq. (2), it follows

$$\overline{h} = (6.61 + 8.09) \text{ W/m}^2 \cdot \text{K} = 14.7 \text{ W/m}^2 \cdot \text{K}$$

From Eq. (1), with  $A_s/V = 1/d$ , where  $d$  is the tile thickness, the time-to-cool is found as

$$\frac{40 - 25}{140 - 25} = \exp \left[ - \frac{14.7 \text{ W/m}^2 \cdot \text{K} \times t_f}{2225 \text{ kg/m}^3 \times 0.010 \text{ m} \times 835 \text{ J/kg} \cdot \text{K}} \right]$$

$$t_f = 2574 \text{ s} = 42.9 \text{ min} \quad \leftarrow$$

Using the *IHT Lumped Capacitance Model* with the *Correlations Tool, Free Convection, Flat Plate*, we can perform the analysis where both  $h_{cv}$  and  $h_{rad}$  are evaluated as a function of the tile temperature. The time-to-cool is

$$t_f = 2860 \text{ s} = 47.7 \text{ min} \quad \leftarrow$$

which is 10% higher than the approximate value.

(b) Considering parallel flow with a velocity,  $u_\infty = 10 \text{ m/s}$  over the tile, the Reynolds number is

$$Re_L = \frac{u_\infty L}{\nu} = \frac{10 \text{ m/s} \times 0.200 \text{ m}}{18.96 \times 10^{-6} \text{ m}^2/\text{s}} = 1.055 \times 10^5$$

but, assuming the flow is turbulent at the upstream edge, use Eq. 7.38 with  $A = 0$  to estimate  $\overline{h}_{cv}$ ,

$$\overline{Nu}_L = 0.037 Re_L^{4/5} Pr^{1/3} = 0.037 (1.055 \times 10^5)^{4/5} (0.7027)^{1/3} = 343.3$$

$$\overline{h}_{cv} = \overline{Nu}_L k/L = 343.3 \times 0.0286 \text{ W/m} \cdot \text{K} / 0.200 \text{ m} = 49.1 \text{ W/m}^2 \cdot \text{K}$$

Hence, using Eqs. (2) and (1), find

$$\overline{h} = 57.2 \text{ W/m}^2 \cdot \text{K} \quad t_f = 661 \text{ s} = 11.0 \text{ min} \quad \leftarrow$$

**COMMENTS:** (1) For the conditions of part (a),  $Bi = hd/k = 14.7 \text{ W/m}^2 \cdot \text{K} \times 0.01 \text{ m} / 1.4 \text{ W/m} \cdot \text{K} = 0.105$ . We conclude that the lumped capacitance analysis is marginally applicable. For the condition of part (b),  $Bi = 0.4$  and, hence, we need to consider spatial effects as explained in Section 5.4. If we considered spatial effects, would our estimates for the time-to-cool be greater or less than those from the foregoing analysis?

(2) For the conditions of part (a), the convection and radiation coefficients are shown in the plot below as a function of cooling time. Can you use this information to explain the relative magnitudes of the  $t_f$  estimates?

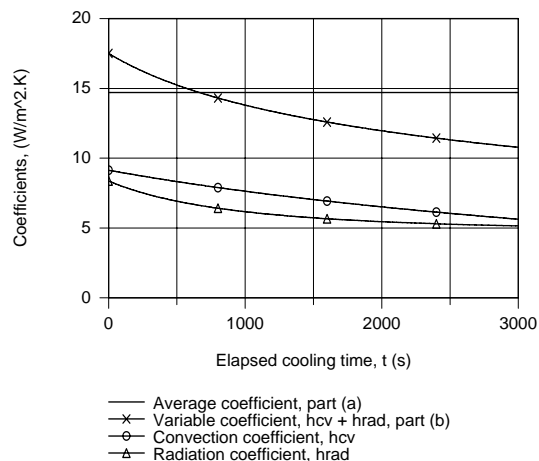

## PROBLEM 9.47

**KNOWN:** Stacked IC boards within a duct dissipating 500 W with prescribed air flow inlet temperature, flow rate, and internal convection coefficient. Outer surface has emissivity of 0.5 and is exposed to ambient air and large surroundings at 25°C.

**FIND:** Develop a model to estimate outlet temperature of the air,  $T_{m,o}$ , and the average surface temperature of the duct,  $\bar{T}_s$ , following these steps: (a) Estimate the average free convection for the outer surface,  $\bar{h}_o$ , assuming an average surface temperature of 37°C; (b) Estimate the average (linearized) radiation coefficient for the outer surface,  $\bar{h}_{rad}$ , assuming an average surface temperature of 37°C; (c) Perform an overall energy balance on the duct considering (i) advection of the air flow, (ii) dissipation of electrical power in the ICs, and (iii) heat transfer from the fluid to the ambient air and surroundings. Express the last process in terms of thermal resistances between the mean fluid temperature,  $\bar{T}_m$ , and the outer temperatures  $T_\infty$  and  $T_{sur}$ ; (d) Substituting numerical values into the expression of part (c), calculate  $T_{m,o}$  and  $\bar{T}_s$ ; comment on your results and the assumptions required to develop your model.

**SCHEMATIC:**

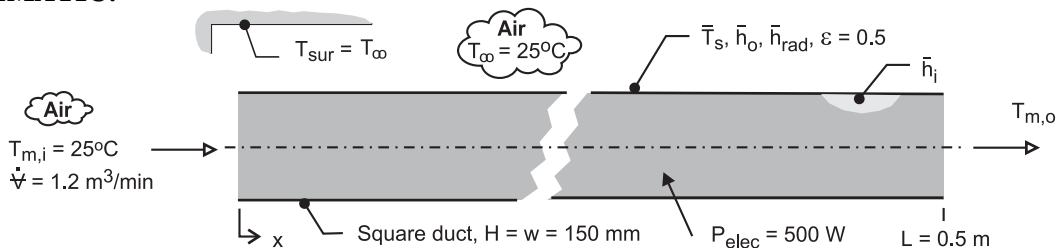

**ASSUMPTIONS:** (1) Steady-state conditions, (2) Air in duct is ideal gas with negligible viscous dissipation and pressure variation, (3) Constant properties, (4) Power dissipated in IC boards nearly uniform in longitudinal direction, (5) Ambient air is quiescent, and (5) Surroundings are isothermal and large relative to the duct.

**PROPERTIES:** Table A-4, Air ( $T_f = (\bar{T}_s + T_\infty)/2 = 304$  K):  $\nu = 1.629 \times 10^{-5}$  m<sup>2</sup>/s,  $\alpha = 2.309 \times 10^{-5}$  m<sup>2</sup>/s,  $k = 0.0266$  W/m·K,  $\beta = 0.003289$  K<sup>-1</sup>,  $Pr = 0.706$ ,  $\rho = 1.148$  kg/m<sup>3</sup>,  $c_p = 1007$  J/kg·K.

**ANALYSIS:** (a) *Average, free-convection coefficient over the duct.* Heat loss by free convection occurs on the vertical sides and horizontal top and bottom. The methodology for estimating the average coefficient assuming the average duct surface temperature  $\bar{T}_s = 37^\circ\text{C}$  follows that of Example 9.3. For the *vertical sides*, from Eq. 9.25 with  $L = H$ , find

$$Ra_L = \frac{g\beta(\bar{T}_s - T_\infty)H^3}{\nu\alpha}$$

$$Ra_L = \frac{9.8 \text{ m/s}^2 \times 0.003289 \text{ K}^{-1} (37 - 25) \text{ K} \times (0.150 \text{ m})^3}{1.629 \times 10^{-5} \text{ m}^2/\text{s} \times 2.309 \times 10^{-5} \text{ m}^2/\text{s}} = 3.47 \times 10^6$$

The free convection is laminar, and from Eq. 9.27,

$$\overline{Nu}_L = 0.68 + \frac{0.670 Ra_L^{1/4}}{\left[1 + (0.492/Pr)^{9/16}\right]^{4/9}}$$

Continued.....

**PROBLEM 9.47 (Cont.)**

$$\overline{\text{Nu}}_L = \frac{\bar{h}_v H}{k} = 0.68 + \frac{0.670 \times (3.47 \times 10^6)^{1/4}}{\left[1 + (0.492/0.706)^{9/16}\right]^{4/9}} = 22.9$$

$$\bar{h}_v = 4.05 \text{ W/m}^2 \cdot \text{K}$$

For the top and bottom surfaces,  $L_c = (A_s/P) = (w \times L)/(2w + 2L) = 0.0577 \text{ m}$ , hence,  $\text{Ra}_L = 1.974 \times 10^5$  and with Eqs. 9.30 and 9.32, respectively,

$$\text{Top surface:} \quad \overline{\text{Nu}}_L = \frac{\bar{h}_t L_c}{k} = 0.54 \text{ Ra}_L^{1/4}; \quad \bar{h}_t = 5.25 \text{ W/m}^2 \cdot \text{K}$$

$$\text{Bottom surface:} \quad \overline{\text{Nu}}_L = \frac{\bar{h}_b L_c}{k} = 0.52 \text{ Ra}_L^{1/5}; \quad \bar{h}_b = 2.75 \text{ W/m}^2 \cdot \text{K}$$

The average coefficient for the entire duct is

$$\bar{h}_{\text{cv},o} = (2\bar{h}_v + \bar{h}_t + \bar{h}_b)/4 = (2 \times 4.05 + 5.25 + 2.75) \text{ W/m}^2 \cdot \text{K}/4 = 4.03 \text{ W/m}^2 \cdot \text{K} \quad <$$

(b) *Average (linearized) radiation coefficient over the duct.* Heat loss by radiation exchange between the duct outer surface and the surroundings on the vertical sides and horizontal top and bottom. With  $\bar{T}_s = 37^\circ\text{C}$ , from Eq. 1.9,

$$\bar{h}_{\text{rad}} = \varepsilon \sigma (\bar{T}_s + T_{\text{sur}}) (\bar{T}_s^2 + T_{\text{sur}}^2)$$

$$\bar{h}_{\text{rad}} = 0.5 \times 5.67 \times 10^{-8} \text{ W/m}^2 \cdot \text{K}^4 (310 + 298) (310^2 + 298^2) \text{ K}^3 = 3.2 \text{ W/m}^2 \cdot \text{K} \quad <$$

(c) *Overall energy balance on the fluid in the duct.* The control volume is shown in the schematic below and the energy balance is

$$\dot{E}_{\text{in}} - \dot{E}_{\text{out}} + \dot{E}_{\text{gen}} = 0$$

$$-q_{\text{adv}} + P_{\text{elec}} - q_{\text{out}} = 0 \quad (1)$$

The advection term has the form, with  $\dot{m} = \dot{V}\rho$ ,

$$q_{\text{adv}} = \dot{m} c_p (T_{m,o} - T_{m,i}) \quad (2)$$

and the heat rate  $q_{\text{out}}$  is represented by the thermal circuit shown below and has the form, with  $T_{\text{sur}} = T_\infty$ ,

$$q_{\text{out}} = \frac{\bar{T}_m - T_\infty}{R_{\text{cv},i} + (1/R_{\text{cv},o} + 1/R_{\text{rad}})^{-1}} \quad (3)$$

where  $\bar{T}_m$  is the average mean temperature of the fluid,  $(T_{m,i} + T_{m,o})/2$ . The thermal resistances are evaluated with  $A_s = 2(w + H)L = 0.3 \text{ m}^2$  as

$$R_{\text{cv},i} = 1/\bar{h}_i A_s \quad (4)$$

$$R_{\text{cv},o} = 1/\bar{h}_{\text{cv},o} A_s \quad (5)$$

$$R_{\text{rad}} = 1/\bar{h}_{\text{rad}} A_s \quad (6)$$

Continued ...

### PROBLEM 9.47 (Cont.)

Using this energy balance, the outlet temperature of the air can be calculated. From the thermal circuit, the average surface temperature can be calculated from the relation

$$q_{\text{out}} = (\bar{T}_m - \bar{T}_s) / R_{\text{cv},i} \quad (7)$$

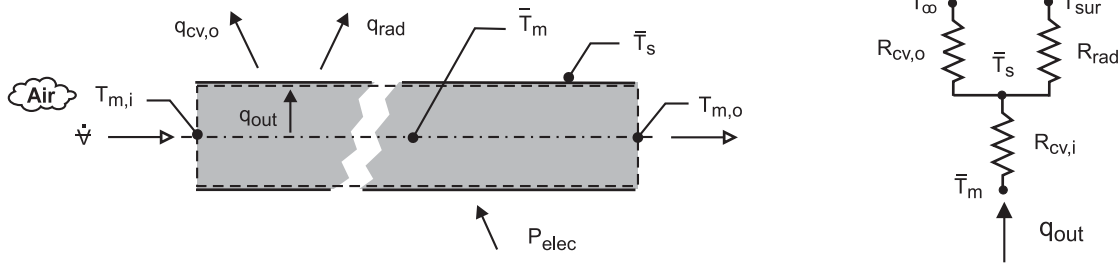

(d) *Calculating  $T_{m,o}$  and  $\bar{T}_s$ .* Substituting numerical values into the expressions of Part (c), find

$$T_{m,o} = 45.7^\circ\text{C} \quad \bar{T}_s = 34.0^\circ\text{C} \quad <$$

The heat rates and thermal resistance results are

$$\begin{aligned} q_{\text{adv}} &= 480.5 \text{ W} & q_{\text{out}} &= 19.5 \text{ W} \\ R_{\text{cv},i} &= 0.0667 \text{ K/W} & R_{\text{cv},o} &= 0.827 \text{ K/W} & R_{\text{rad}} &= 1.05 \text{ K/W} \end{aligned}$$

**COMMENTS:** (1) We assumed  $\bar{T}_s = 37^\circ\text{C}$  for estimating  $\bar{h}_{\text{cv},o}$  and  $\bar{h}_{\text{rad}}$ , whereas from the energy balance we found the value was  $34.0^\circ\text{C}$ . Performing an iterative solution, with different assumed  $\bar{T}_s$  we would find that the results are not sensitive to the  $\bar{T}_s$  value, and that the foregoing results are satisfactory.

(2) From the results of Part (d) for the heat rates, note that about 4% of the electrical power is transferred from the duct outer surface. The present arrangement does not provide a practical means to cool the IC boards.

(3) Note that  $T_{m,i} < T_s < T_{m,o}$ . As such, we can't utilize the usual log-mean temperature (LMTD) expression, Eq. 8.44, in the rate equation for the internal flow analysis. It is for this reason we used the overall coefficient approach representing the heat transfer by the thermal circuit. The average surface temperature of the duct,  $\bar{T}_s$ , is only used for the purposes of estimating  $\bar{h}_{\text{cv},o}$  and  $\bar{h}_{\text{rad}}$ . We represented the effective temperature difference between the fluid and the ambient/surroundings as  $\bar{T}_m - T_\infty$ . Because the fluid temperature rise is not very large, this assumption is a reasonable one.

### PROBLEM 9.48

**KNOWN:** Parallel flow of air over a highly polished aluminum plate flat plate maintained at a uniform temperature  $T_s = 47^\circ\text{C}$  by a series of segmented heaters.

**FIND:** (a) Electrical power required to maintain the heater segment covering the section between  $x_1 = 0.2$  m and  $x_2 = 0.3$  m and (b) Temperature that the surface would reach if the air blower malfunctions and heat transfer occurs by free, rather than forced, convection.

**SCHEMATIC:**

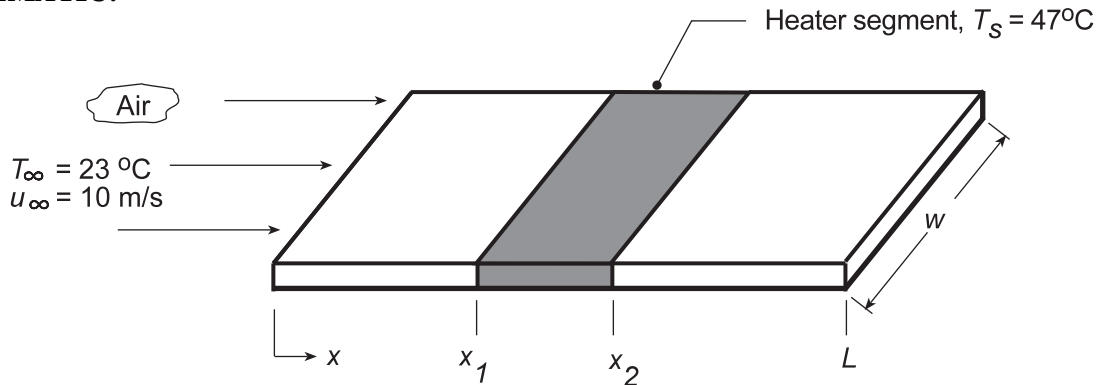

**ASSUMPTIONS :** (1) Steady-state conditions, (2) Backside of plate is perfectly insulated, (3) Flow is turbulent over the entire length of plate, part (a), (4) Ambient air is extensive, quiescent at  $23^\circ\text{C}$  for part (b).

**PROPERTIES:** Table A.4, Air ( $T_f = (T_s + T_\infty)/2 = 308\text{K}$ ):  $\nu = 16.69 \times 10^{-6} \text{ m}^2/\text{s}$ ,  $k = 0.02689 \text{ W/m}\cdot\text{K}$ ,  $\alpha = 23.68 \times 10^{-6} \text{ m}^2/\text{s}$ ,  $\text{Pr} = 0.7059$ ,  $\beta = 1/T_f$ ; Table A.12, Aluminum, highly polished:  $\varepsilon = 0.03$ .

**ANALYSIS:** (a) The power required to maintain the segmented heater ( $x_1 - x_2$ ) is

$$P_e = \bar{h}_{x_1-x_2} (x_2 - x_1) w (T_s - T_\infty) \quad (1)$$

where  $\bar{h}_{x_1-x_2}$  is the average coefficient for the section between  $x_1$  and  $x_2$ , and can be approximated as the average of the local values at  $x_1$  and  $x_2$ ,

$$\bar{h}_{x_1-x_2} = (h(x_1) + h(x_2))/2 \quad (2)$$

Using Eq. 7.36 appropriate for fully turbulent flow, with  $\text{Re}_x = u_\infty x / \nu$ ,

$$\text{Nu}_{x_1} = 0.0296 \text{Re}_x^{4/5} \text{Pr}^{1/3}$$

$$\text{Nu}_{x_1} = 0.0296 \left( \frac{10 \text{ m/s} \times 0.2 \text{ m}}{16.69 \times 10^{-6} \text{ m}^2/\text{s}} \right)^{4/5} (0.7059)^{1/3} = 304.6$$

$$h_{x_1} = \text{Nu}_{x_1} k / x_1 = 304.6 \times 0.02689 \text{ W/m}\cdot\text{K} / 0.2 \text{ m} = 40.9 \text{ W/m}^2\cdot\text{K}$$

$$\text{Nu}_{x_2} = 421.3 \quad h_{x_2} = 37.8 \text{ W/m}^2\cdot\text{K}$$

Hence, from Eq (2) to obtain  $\bar{h}_{x_1-x_2}$  and Eq. (1) to obtain  $P_e$ ,

$$\bar{h}_{x_1-x_2} = (40.9 + 37.8) \text{ W/m}^2\cdot\text{K} / 2 = 39.4 \text{ W/m}^2\cdot\text{K}$$

$$P_e = 39.4 \text{ W/m}^2\cdot\text{K} (0.3 - 0.2) \text{ m} \times 0.2 \text{ m} (47 - 23)^\circ\text{C} = 18.9 \text{ W}$$

<

Continued...

**PROBLEM 9.48 (Cont.)**

(b) Without the airstream flow, the heater segment experiences free convection and radiation exchange with the surroundings,

$$P_e = \left[ \bar{h}_{cv} (T_s - T_\infty) + \varepsilon \sigma (T_s^4 - T_{sur}^4) \right] (x_2 - x_1) w \quad (3)$$

We will assume that the free convection coefficient,  $\bar{h}_{cv}$ , for the segment is the same as that for the entire plate. Using the correlation for a flat plate, Eq. 9.30, with

$$Ra_L = \frac{g\beta\Delta T L_c^3}{\nu\alpha} \quad L_c = \frac{A_s}{P} = \frac{0.2 \times 0.5 \text{ m}^2}{2(0.2 + 0.5) \text{ m}} = 0.0714 \text{ m}$$

and evaluating properties at  $T_f = 308 \text{ K}$ ,

$$Ra_L = \frac{9.8 \text{ m/s}^2 (1/308 \text{ K})(47 - 23)(0.0714 \text{ m})^3}{16.69 \times 10^{-6} \text{ m}^2/\text{s}^2 \times 23.68 \times 10^{-6} \text{ m}^2/\text{s}} = 7.033 \times 10^5$$

$$\overline{Nu}_L = 0.54 Ra_L^{1/4} = 0.54 (7.033 \times 10^5)^{1/4} = 15.64$$

$$\bar{h}_{cv} = \overline{Nu}_L k / L_c = 15.64 \times 0.02689 \text{ W/m} \cdot \text{K} / 0.0714 \text{ m} = 5.89 \text{ W/m}^2 \cdot \text{K}$$

Substituting numerical values into Eq. (3),

$$18.9 \text{ W} = \left[ 5.89 \text{ W/m}^2 \cdot \text{K} (T_s - 296) + 0.03 \times 5.67 \times 10^{-8} \text{ W/m}^2 \cdot \text{K}^4 (T_s^4 - 296^4) \right] (0.3 - 0.2) \text{ m} \times 0.2 \text{ m}$$

$$T_s = 447 \text{ K} = 174^\circ \text{C} \quad \leftarrow$$

**COMMENTS:** Recognize that in part (b), the assumed value for  $T_f = 308 \text{ K}$  is a poor approximation. Using the above relations in the IHT work space with the *Properties Tool*, find that  $T_s = 406 \text{ K} = 133^\circ \text{C}$  using the properly evaluated film temperature ( $T_f$ ) and temperature difference ( $\Delta T$ ) in the correlation. From this analysis,  $\bar{h}_{cv} = 8.29 \text{ W/m}^2 \cdot \text{K}$  and  $h_{rad} = 0.3 \text{ W/m}^2 \cdot \text{K}$ . Because of the low emissivity of the plate, the radiation exchange process is not significant.

### PROBLEM 9.49

**KNOWN:** Correlation for estimating the average free convection coefficient for the exterior surface of a long horizontal rectangular cylinder (duct) exposed to a quiescent fluid. Consider a horizontal 0.15 m-square duct with a surface temperature of 35°C passing through ambient air at 15°C.

**FIND:** (a) Calculate the average convection coefficient and the heat rate per unit length using the H-D correlation, (b) Calculate the average convection coefficient and the heat rate per unit length considering the duct as formed by vertical plates (sides) and horizontal plates (top and bottom), and (c) Using an appropriate correlation, calculate the average convection coefficient and the heat rate per unit length for a duct of circular cross-section having a diameter equal to the wetted perimeter of the rectangular duct of part (a). Do you expect the estimates for parts (b) and (c) to be lower or higher than those obtained with the H-D correlation? Explain the differences, if any.

**SCHEMATIC:**

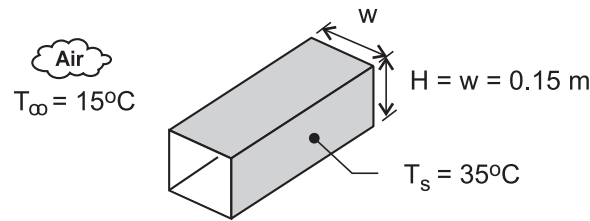

**ASSUMPTIONS:** (1) Steady-state conditions, (2) Ambient air is quiescent, (3) Duct surface has uniform temperature.

**PROPERTIES:** Table A-4, air ( $T_f = (T_s + T_\infty)/2 = 298$  K, 1 atm):  $\nu = 1.571 \times 10^{-5}$  m<sup>2</sup>/s,  $k = 0.0261$  W/m·K,  $\alpha = 2.22 \times 10^{-5}$  m<sup>2</sup>/s,  $Pr = 0.708$ .

**ANALYSIS:** (a) The Hahn-Didion (H-D) correlation [ASHRAE Proceedings, Part 1, pp 262-67, 1972] has the form

$$\overline{Nu}_p = 0.55 Ra_p^{1/4} \left( \frac{H}{p} \right)^{1/8} \quad Ra_p \leq 10^7$$

where the characteristic length is the half-perimeter,  $p = (w + H)$ , and  $w$  and  $H$  are the horizontal width and vertical height, respectively, of the duct. The thermophysical properties are evaluated at the film temperature. Using *IHT*, with the correlation and thermophysical properties, the following results were obtained.

$Ra_p$	$\overline{Nu}_p$	$\overline{h}_p$ (W/m <sup>2</sup> ·K)	$q'_p$ (W/m)	<
$5.08 \times 10^7$	42.6	3.71	44.5	

where the heat rate per unit length of the duct is

$$q'_p = \overline{h}_p 2(H + w)(T_s - T_\infty).$$

(b) Treating the duct as a combination of horizontal (*top*: hot-side up and *bottom*: hot-side down) and two vertical plates (*v*) as considered in Example 9.3, the following results were obtained

$\overline{h}_t$	$\overline{h}_b$	$\overline{h}_v$	$\overline{h}_{hv}$	$q'_{hv}$	<
(W/m <sup>2</sup> ·K)	(W/m <sup>2</sup> ·K)	(W/m <sup>2</sup> ·K)	(W/m <sup>2</sup> ·K)	(W/m)	
5.62	2.81	4.78	4.50	54.0	

Continued...

### PROBLEM 9.49 (Cont.)

where the average coefficient and heat rate per unit length for the horizontal-vertical plate duct are

$$\bar{h}_{hv} = (\bar{h}_t + \bar{h}_b + 2\bar{h}_v) / 4$$

$$q'_{hv} = \bar{h}_{hv} 2(H + w)(T_s - T_\infty).$$

(c) Consider a circular duct having a wetted perimeter equal to that of the rectangular duct, for which the diameter is

$$\pi D = 2(H + w) \qquad D = 0.191 \text{ m}$$

Using the Churchill-Chu correlation, Eq. 9.34, the following results are obtained.

$Ra_D$	$\overline{Nu}_D$	$\bar{h}_D \left( W / m^2 \cdot K \right)$	$q'_D \left( W / m \right)$	
$1.31 \times 10^7$	30.6	4.19	50.3	<

where the heat rate per unit length for the circular duct is

$$q'_D = \pi D \bar{h}_D (T_s - T_\infty).$$

**COMMENTS:** (1) The H-D correlation, based upon experimental measurements, provided the lowest estimate for  $\bar{h}$  and  $q'$ . The circular duct analysis results are in closer agreement than are those for the horizontal-vertical plate duct.

(2) An explanation for the relative difference in  $\bar{h}$  and  $q'$  values can be drawn from consideration of the boundary layers and induced flows around the surfaces. Viewing the cross-section of the square duct, recognize that flow induced by the bottom surface flows around the vertical sides, joining the vertical plume formed on the top surface. The flow over the vertical sides is quite different than would occur if the vertical surface were modeled as an *isolated* vertical surface. Also, flow from the top surface is likewise modified by flow rising from the sides, and doesn't behave as an *isolated* horizontal surface. It follows that treating the duct as a combination of horizontal-vertical plates (hv results), each considered as *isolated*, would over estimate the average coefficient and heat rate.

(3) It follows that flow over the horizontal cylinder more closely approximates the situation of the square duct. However, the flow is more streamlined; thinnest along the bottom, and of increasing thickness as the flow rises and eventually breaks away from the upper surface. The edges of the duct disrupt the rising flow, lowering the convection coefficient. As such, we expect the horizontal cylinder results to be systematically higher than for the H-D correlation that accounts for the edges.



## PROBLEM 9.50

**KNOWN:** Dimensions, emissivity and operating temperatures of a wood burning stove. Temperature of ambient air and surroundings.

**FIND:** Rate of heat transfer.

**SCHEMATIC:**

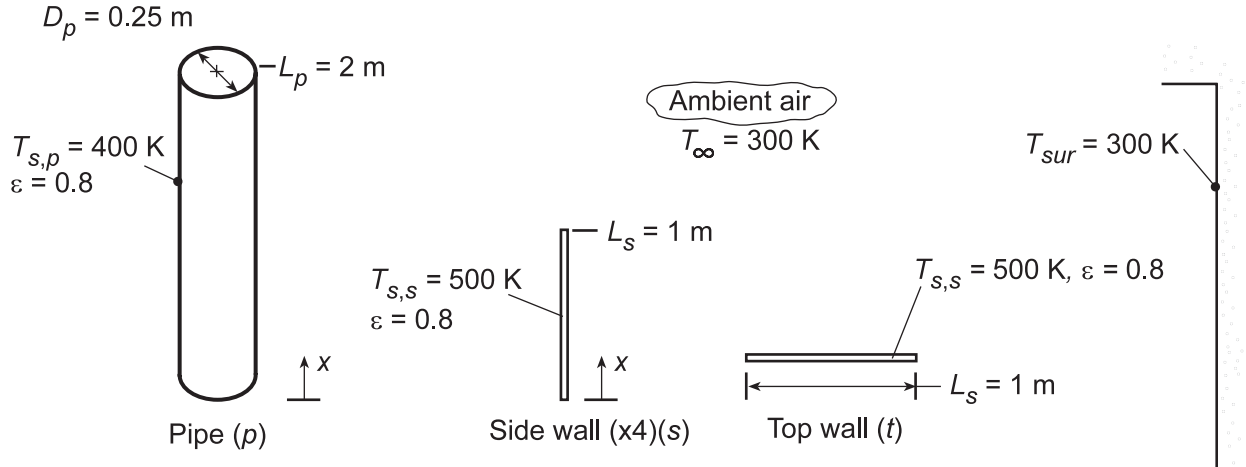

**ASSUMPTIONS:** (1) Steady-state, (2) Quiescent air, (3) Negligible heat transfer from pipe elbow, (4) Free convection from pipe corresponds to that from a vertical plate.

**PROPERTIES:** Table A.4, air ( $T_f = 400$  K):  $\nu = 26.41 \times 10^{-6}$  m<sup>2</sup>/s,  $k = 0.0338$  W/m·K,  $\alpha = 38.3 \times 10^{-6}$  m<sup>2</sup>/s,  $\beta = 0.0025$  K<sup>-1</sup>,  $Pr = 0.69$ . Table A.4, air ( $T_f = 350$  K):  $\nu = 20.92 \times 10^{-6}$  m<sup>2</sup>/s,  $k = 0.030$  W/m·K,  $\alpha = 29.9 \times 10^{-6}$  m<sup>2</sup>/s,  $Pr = 0.70$ ,  $\beta = 0.00286$  K<sup>-1</sup>.

**ANALYSIS:** Three distinct contributions to the heat rate are made by the 4 side walls, the top surface, and the pipe surface. Hence  $q_t = 4q_s + q_t + q_p$ , where each contribution includes transport due to convection and radiation.

$$q_s = \bar{h}_s L_s^2 (T_{s,s} - T_\infty) + h_{\text{rad},s} L_s^2 (T_{s,s} - T_{\text{sur}})$$

$$q_t = \bar{h}_t L_s^2 (T_{s,s} - T_\infty) + h_{\text{rad},s} L_s^2 (T_{s,s} - T_{\text{sur}})$$

$$q_p = \bar{h}_p (\pi D_p L_p) (T_{s,p} - T_\infty) + h_{\text{rad},p} (\pi D_p L_p) (T_{s,p} - T_{\text{sur}})$$

The radiation coefficients are

$$h_{\text{rad},s} = \varepsilon \sigma (T_{s,s} + T_{\text{sur}}) (T_{s,s}^2 + T_{\text{sur}}^2) = 12.3 \text{ W/m}^2 \cdot \text{K}$$

$$h_{\text{rad},p} = \varepsilon \sigma (T_{s,p} + T_{\text{sur}}) (T_{s,p}^2 + T_{\text{sur}}^2) = 7.9 \text{ W/m}^2 \cdot \text{K}$$

For the stove side walls,  $Ra_{L,s} = g\beta (T_{s,s} - T_\infty) L_s^3 / \alpha \nu = 4.84 \times 10^9$ . Similarly, with  $(A_s/P) = L_s^2 / 4L_s = 0.25$  m,  $Ra_{L,t} = 7.57 \times 10^7$  for the top surface, and with  $L_p = 2$  m,  $Ra_{L,p} = 3.59 \times 10^{10}$  for the stove pipe.

For the side walls and the pipe, the average convection coefficient may be determined from Eq. 9.26,

$$\bar{Nu}_L = \left\{ 0.825 + \frac{0.387 Ra_L^{1/6}}{\left[ 1 + (0.492/Pr)^{9/16} \right]^{8/27}} \right\}^2$$

Continued...

### PROBLEM 9.50 (Cont.)

which yields  $\overline{\text{Nu}}_{L,s} = 199.9$  and  $\overline{\text{Nu}}_{L,p} = 377.6$ . For the top surface, the average coefficient may be obtained from Eq. 9.31,

$$\overline{\text{Nu}}_L = 0.15\text{Ra}_L^{1/3}$$

which yields  $\overline{\text{Nu}}_{L,t} = 63.5$ . With  $\bar{h} = \overline{\text{Nu}}(k/L)$ , the convection coefficients are

$$\bar{h}_s = 6.8 \text{ W/m}^2 \cdot \text{K}, \quad \bar{h}_t = 8.6 \text{ W/m}^2 \cdot \text{K}, \quad \bar{h}_p = 5.7 \text{ W/m}^2 \cdot \text{K}$$

Hence,

$$q_s = (\bar{h}_s + h_{\text{rad},s})L_s^2(T_{s,s} - 300 \text{ K}) = 19.1 \text{ W/m}^2 \cdot \text{K} (1 \text{ m}^2)(200 \text{ K}) = 3820 \text{ W}$$

$$q_t = (\bar{h}_t + h_{\text{rad},s})L_s^2(T_{s,s} - 300 \text{ K}) = 20.9 \text{ W/m}^2 \cdot \text{K} (1 \text{ m}^2)(200 \text{ K}) = 4180 \text{ W}$$

$$q_p = (\bar{h}_p + h_{\text{rad},p})(\pi D_p L_p)(T_{s,p} - 300 \text{ K}) = 13.6 \text{ W/m}^2 \cdot \text{K} (\pi \times 0.25 \text{ m} \times 2 \text{ m})(100 \text{ K}) = 2140 \text{ W}$$

and the total heat rate is

$$q_{\text{tot}} = 4q_s + q_t + q_p = 21,600 \text{ W}$$

<

**COMMENTS:** The amount of heat transfer is significant, and the stove would be capable of maintaining comfortable conditions in a large, living space under harsh (cold) environmental conditions.

### PROBLEM 9.51

**KNOWN:** Plate,  $1\text{ m} \times 1\text{ m}$ , inclined at  $45^\circ$  from the vertical is exposed to a net radiation heat flux of  $300\text{ W/m}^2$ ; backside of plate is insulated and ambient air is at  $0^\circ\text{C}$ .

**FIND:** Temperature plate reaches for the prescribed conditions.

**SCHEMATIC:**

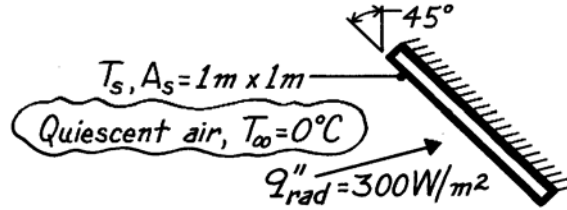

**ASSUMPTIONS:** (1) Net radiation heat flux ( $300\text{ W/m}^2$ ) includes exchange with surroundings, (2) Ambient air is quiescent, (3) No heat losses from backside of plate, (4) Steady-state conditions.

**PROPERTIES:** Table A-4, Air (assuming  $T_s = 84^\circ\text{C}$ ,  $T_f = (T_s + T_\infty)/2 = (84 + 0)^\circ\text{C}/2 = 315\text{ K}$ , 1 atm):  $\nu = 17.40 \times 10^{-6}\text{ m}^2/\text{s}$ ,  $k = 0.0274\text{ W/m}\cdot\text{K}$ ,  $\alpha = 24.7 \times 10^{-6}\text{ m}^2/\text{s}$ ,  $\text{Pr} = 0.705$ ,  $\beta = 1/T_f$ .

**ANALYSIS:** From an energy balance on the plate, it follows that  $q''_{\text{rad}} = q''_{\text{conv}}$ . That is, the net radiation heat flux into the plate is equal to the free convection heat flux to the ambient air. The temperature of the surface can be expressed as

$$T_s = T_\infty + q''_{\text{rad}} / \bar{h}_L \quad (1)$$

where  $\bar{h}_L$  must be evaluated from an appropriate correlation. Since this is the *bottom surface of a heated inclined plate*, “ $g$ ” may be replaced by “ $g \cos \theta$ ”; hence using Eq. 9.25, find

$$\text{Ra}_L = \frac{g \cos \theta \beta (T_s - T_\infty) L^3}{\nu \alpha} = \frac{9.8\text{ m/s}^2 \times \cos 45^\circ (1/315\text{ K})(84 - 0)\text{ K} (1\text{ m})^3}{17.40 \times 10^{-6}\text{ m}^2/\text{s} \times 24.7 \times 10^{-6}\text{ m}^2/\text{s}} = 4.30 \times 10^9.$$

Since  $\text{Ra}_L > 10^9$ , conditions are turbulent and Eq. 9.26 is appropriate for estimating  $\overline{\text{Nu}}_L$

$$\overline{\text{Nu}}_L = \left\{ 0.825 + \frac{0.387 \text{Ra}_L^{1/6}}{\left[ 1 + (0.492/\text{Pr})^{9/16} \right]^{8/27}} \right\}^2 \quad (2)$$

$$\overline{\text{Nu}}_L = \left\{ 0.825 + \frac{0.387 (4.30 \times 10^9)^{1/6}}{\left[ 1 + (0.492/0.705)^{9/16} \right]^{8/27}} \right\}^2 = 193.2$$

$$\bar{h}_L = \overline{\text{Nu}}_L k / L = 193.2 \times 0.0274\text{ W/m}\cdot\text{K} / 1\text{ m} = 5.29\text{ W/m}^2\cdot\text{K}. \quad (3)$$

Substituting  $\bar{h}_L$  from Eq. (3) into Eq. (1), the plate temperature is

$$T_s = 0^\circ\text{C} + 300\text{ W/m}^2 / 5.29\text{ W/m}^2\cdot\text{K} = 57^\circ\text{C}. \quad <$$

**COMMENTS:** Note that the resulting value of  $T_s \approx 57^\circ\text{C}$  is substantially lower than the assumed value of  $84^\circ\text{C}$ . The calculation should be repeated with a new estimate of  $T_s$ , say,  $60^\circ\text{C}$ . An alternate approach is to write Eq. (2) in terms of  $T_s$ , the unknown surface temperature and then combine with Eq. (1) to obtain an expression which can be solved, by trial-and-error, for  $T_s$ .

## PROBLEM 9.52

**KNOWN:** Horizontal rod immersed in water maintained at a prescribed temperature.

**FIND:** Free convection heat transfer rate per unit length of the rod,  $q'_{\text{conv}}$

**SCHEMATIC:**

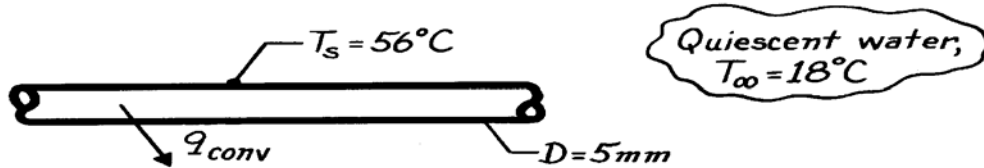

**ASSUMPTIONS:** (1) Water is extensive, quiescent medium.

**PROPERTIES:** Table A-6, Water ( $T_f = (T_s + T_\infty)/2 = 310\text{K}$ ):  $\rho = 1/v_f = 993.0\text{ kg/m}^3$ ,  $\nu = \mu/\rho = 695 \times 10^{-6}\text{ N}\cdot\text{s/m}^2/993.0\text{ kg/m}^3 = 6.999 \times 10^{-7}\text{ m}^2/\text{s}$ ,  $\alpha = k/\rho c = 0.628\text{ W/m}\cdot\text{K}/993.0\text{ kg/m}^3 \times 4178\text{ J/kg}\cdot\text{K} = 1.514 \times 10^{-7}\text{ m}^2/\text{s}$ ,  $\text{Pr} = 4.62$ ,  $\beta = 361.9 \times 10^{-6}\text{ K}^{-1}$ .

**ANALYSIS:** The heat rate per unit length by free convection is given as

$$q'_{\text{conv}} = \bar{h}_D \cdot \pi D (T_s - T_\infty). \quad (1)$$

To estimate  $\bar{h}_D$ , first find the Rayleigh number, Eq. 9.25,

$$\text{Ra}_D = \frac{g \beta (T_s - T_\infty) D^3}{\nu \alpha} = \frac{9.8\text{ m/s}^2 (361.9 \times 10^{-6}\text{ K}^{-1}) (56 - 18)\text{ K} (0.005\text{ m})^3}{6.999 \times 10^{-7}\text{ m}^2/\text{s} \times 1.514 \times 10^{-7}\text{ m}^2/\text{s}} = 1.587 \times 10^5$$

and use Eq. 9.34 for a horizontal cylinder,

$$\bar{\text{Nu}}_D = \left\{ 0.60 + \frac{0.387 \text{Ra}_D^{1/6}}{\left[ 1 + (0.599/\text{Pr})^{9/16} \right]^{8/27}} \right\}^2$$

$$\bar{\text{Nu}}_D = \left\{ 0.60 + \frac{0.387 (1.587 \times 10^5)^{1/6}}{\left[ 1 + (0.599/4.62)^{9/16} \right]^{8/27}} \right\}^2 = 10.40$$

$$\bar{h}_D = \bar{\text{Nu}}_D k / D = 10.40 \times 0.628\text{ W/m}\cdot\text{K} / 0.005\text{ m} = 1306\text{ W/m}^2\cdot\text{K}. \quad (2)$$

Substituting for  $\bar{h}_D$  from Eq. (2) into Eq. (1),

$$q'_{\text{conv}} = 1306\text{ W/m}^2\cdot\text{K} \times \pi (0.005\text{ m}) (56 - 18)\text{ K} = 780\text{ W/m}. \quad <$$

**COMMENTS:** (1) Note the relatively large value of  $\bar{h}_D$ ; if the rod were immersed in air, the heat transfer coefficient would be close to  $5\text{ W/m}^2\cdot\text{K}$ .

(2) Eq. 9.33 with appropriate values of  $C$  and  $n$  from Table 9.1 could also be used to estimate  $\bar{h}_D$ . Find

$$\bar{\text{Nu}}_D = C \text{Ra}_D^n = 0.48 (1.587 \times 10^5)^{0.25} = 9.58$$

$$\bar{h}_D = \bar{\text{Nu}}_D k / D = 9.58 \times 0.628\text{ W/m}\cdot\text{K} / 0.005\text{ m} = 1203\text{ W/m}^2\cdot\text{K}.$$

By comparison with the result of Eq. (2), the disparity of the estimates is ~8%.

### PROBLEM 9.53

**KNOWN:** Horizontal, uninsulated steam pipe passing through a room.

**FIND:** Heat loss per unit length from the pipe.

**SCHEMATIC:**

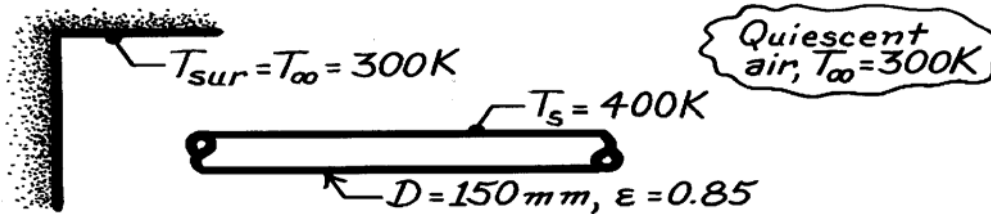

**ASSUMPTIONS:** (1) Pipe surface is at uniform temperature, (2) Air is quiescent medium, (3) Surroundings are large compared to pipe.

**PROPERTIES:** Table A-4, Air ( $T_f = (T_s + T_\infty)/2 = 350 \text{ K}$ , 1 atm):  $\nu = 20.92 \times 10^{-6} \text{ m}^2/\text{s}$ ,  $k = 0.030 \text{ W/m}\cdot\text{K}$ ,  $\alpha = 29.9 \times 10^{-6} \text{ m}^2/\text{s}$ ,  $\text{Pr} = 0.700$ ,  $\beta = 1/T_f = 2.857 \times 10^{-3} \text{ K}^{-1}$ .

**ANALYSIS:** Recognizing that the heat loss from the pipe will be by free convection to the air and by radiation exchange with the surroundings, we can write

$$q' = q'_{\text{conv}} + q'_{\text{rad}} = \pi D \left[ \bar{h}_D (T_s - T_\infty) + \epsilon \sigma (T_s^4 - T_{\text{sur}}^4) \right]. \quad (1)$$

To estimate  $\bar{h}_D$ , first find  $\text{Ra}_L$ , Eq. 9.25, and then use the correlation for a horizontal cylinder, Eq. 9.34,

$$\text{Ra}_L = \frac{g \beta (T_s - T_\infty) D^3}{\nu \alpha} = \frac{9.8 \text{ m/s}^2 (1/350 \text{ K}) (400 - 300) \text{ K} (0.150 \text{ m})^3}{20.92 \times 10^{-6} \text{ m}^2/\text{s} \times 29.9 \times 10^{-6} \text{ m}^2/\text{s}} = 1.511 \times 10^7$$

$$\bar{\text{Nu}}_D = \left\{ 0.60 + \frac{0.387 \text{ Ra}_L^{1/6}}{\left[ 1 + (0.559/\text{Pr})^{9/16} \right]^{8/27}} \right\}^2$$

$$\bar{\text{Nu}}_D = \left\{ 0.60 + \frac{0.387 (1.511 \times 10^7)^{1/6}}{\left[ 1 + (0.559/0.700)^{9/16} \right]^{8/27}} \right\}^2 = 31.88$$

$$\bar{h}_D = \bar{\text{Nu}}_D \cdot k / D = 31.88 \times 0.030 \text{ W/m}\cdot\text{K} / 0.15 \text{ m} = 6.38 \text{ W/m}^2 \cdot \text{K}. \quad (2)$$

Substituting for  $\bar{h}_D$  from Eq. (2) into Eq. (1), find

$$q' = \pi (0.150 \text{ m}) \left[ 6.38 \text{ W/m}^2 \cdot \text{K} (400 - 300) \text{ K} + 0.85 \times 5.67 \times 10^{-8} \text{ W/m}^2 \cdot \text{K}^4 (400^4 - 300^4) \text{ K}^4 \right]$$

$$q' = 301 \text{ W/m} + 397 \text{ W/m} = 698 \text{ W/m}. \quad \leftarrow$$

**COMMENTS:** (1) Note that for this situation, heat transfer by radiation and free convection are of equal importance.

(2) Using Eq. 9.33 with constants  $C, n$  from Table 9.1, the estimate for  $\bar{h}_D$  is

$$\bar{\text{Nu}}_D = C \text{ Ra}_L^n = 0.125 (1.511 \times 10^7)^{0.333} = 30.73$$

$$\bar{h}_D = \bar{\text{Nu}}_D k / D = 30.73 \times 0.030 \text{ W/m}\cdot\text{K} / 0.150 \text{ m} = 6.15 \text{ W/m}^2 \cdot \text{K}.$$

The agreement is within 4% of the Eq. 9.34 result.

## PROBLEM 9.54

**KNOWN:** Diameter and emissivity of horizontal glass cylinder. Temperature of air and surroundings.

**FIND:** Temperature at which lumped capacitance approximation may be applied.

**SCHEMATIC:**

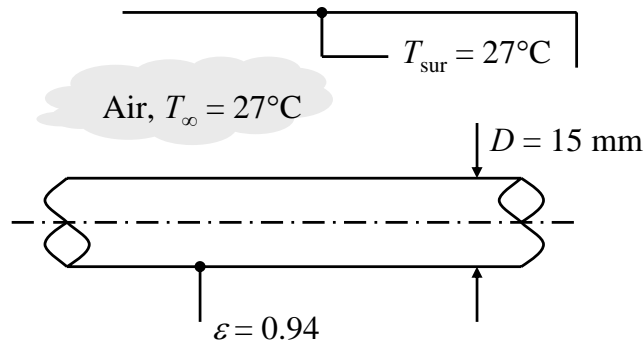

**ASSUMPTIONS:** (1) The quasi-steady approximation holds: the heat transfer coefficient can be evaluated based on steady-state conditions, (2) Air properties can be evaluated at 350 K, (3) Radiation is to large surroundings.

**PROPERTIES:** Table A-3, Glass ( $T = 300$  K):  $k_g = 1.4$  W/m·K; Table A-4, Air ( $T = 350$  K):  $\nu = 20.92 \times 10^{-6}$  m<sup>2</sup>/s,  $\alpha = 29.9 \times 10^{-6}$  m<sup>2</sup>/s,  $k = 30 \times 10^{-3}$  W/m·K,  $Pr = 0.700$ ,  $\beta = 1/T_s = 1/(350$  K) = 0.00286 K<sup>-1</sup>.

**ANALYSIS:** The largest heat transfer coefficient for which the lumped capacitance approximation is valid can be found from  $Bi = 0.1$ , where the characteristic length is the cylinder radius,  $r_o$ . In this case, the heat transfer coefficient should be the effective value that includes both convection and radiation,

$$h_{\text{eff}} = \bar{h} + h_r \quad (1)$$

Therefore, with  $Bi = h_{\text{eff}}D/k_g$ ,

$$h_{\text{eff}} = 0.2 \frac{k_g}{D} = 0.2 \frac{1.4 \text{ W/m} \cdot \text{K}}{0.015 \text{ m}} = 18.67 \text{ W/m}^2 \cdot \text{K} \quad (2)$$

The radiation heat transfer coefficient is given by

$$h_r = \varepsilon \sigma (T_s + T_{\text{sur}})(T_s^2 + T_{\text{sur}}^2) \quad (3)$$

The free convection heat transfer coefficient can be found from the Churchill-Chu correlation,

$$\overline{Nu}_D = \frac{\bar{h}D}{k} = \left\{ 0.60 + \frac{0.387 Ra_D^{1/6}}{\left[ 1 + (0.559 / Pr)^{9/16} \right]^{8/27}} \right\}^2 \quad (4)$$

Continued...

### PROBLEM 9.54 (Cont.)

where the Rayleigh number is:

$$Ra_D = \frac{g\beta(T_s - T_\infty)D^3}{\nu\alpha} \quad (5)$$

Equations (1)-(5) can be solved for the unknowns, including the surface temperature. This can easily be done using *IHT*, but it can also be solved by hand as follows. We begin by taking  $T_s = 400$  K for the purpose of estimating the radiation heat transfer coefficient of Eq. (3):

$$\begin{aligned} h_r &= \varepsilon\sigma(T_s + T_{\text{sur}})(T_s^2 + T_{\text{sur}}^2) \\ &= 0.94 \times 5.67 \times 10^{-8} \text{ W/m}^2 \cdot \text{K}^4 \times (400 + 300)\text{K} \times (400^2 + 300^2)\text{K}^2 = 9.33 \text{ W/m}^2 \cdot \text{K} \end{aligned}$$

From Eqs. (1) and (2),  $\bar{h} = h_{\text{eff}} - h_r = (18.67 - 9.33) \text{ W/m}^2 \cdot \text{K} = 9.34 \text{ W/m}^2 \cdot \text{K}$  and

$$\overline{Nu}_D = \frac{\bar{h}D}{k} = \frac{9.34 \text{ W/m}^2 \cdot \text{K} \times 0.015 \text{ m}}{30 \times 10^{-3} \text{ W/m} \cdot \text{K}} = 4.67$$

Then Eq. (4) can be solved for  $Ra_D$ ,

$$\begin{aligned} Ra_D &= \left\{ \frac{1}{0.387} \left( \sqrt{\overline{Nu}_D} - 0.60 \right) \left[ 1 + (0.559/Pr)^{9/16} \right]^{8/27} \right\}^6 \\ &= \left\{ \frac{1}{0.387} \left( \sqrt{4.67} - 0.60 \right) \left[ 1 + (0.559/0.707)^{9/16} \right]^{8/27} \right\}^6 = 13,200 \end{aligned}$$

Eq. (5) can now be solved for  $T_s$ :

$$T_s = T_\infty + Ra_D \frac{\nu\alpha}{g\beta D^3} = 300 \text{ K} + 13,200 \times \frac{20.92 \times 10^{-6} \text{ m}^2/\text{s} \times 29.9 \times 10^{-6} \text{ m}^2/\text{s}}{9.8 \text{ m/s}^2 \times 0.00286 \text{ K}^{-1} \times (0.015 \text{ m})^3} = 388 \text{ K}$$

This is reasonably close to the initial assumption of  $T_s = 400$  K. Greater accuracy could be obtained by repeating the calculations with the new estimate of  $T_s$  and evaluating air properties at the film temperature. Repeated iterations converge on  $T_s = 395$  K, thus the lumped capacitance approximation is valid for  $T_s < 395$  K. <

**COMMENTS:** (1) Because of the relatively small thermal conductivity of glass, the effective heat transfer coefficient must be fairly small,  $18.67 \text{ W/m}^2 \cdot \text{K}$ , for the lumped capacitance approximation to be valid. (2) The conclusion that lumped capacitance is valid for  $T_s < 395$  K requires further evaluation. If the rod is initially hotter than 395 K, it would be subject to large spatial temperature gradients in the initial stages of cooling. When the temperature meets the Biot criterion, there would still be residual temperature gradients in the rod from the preceding cooling period, so the lumped capacitance method might never be applicable.

### PROBLEM 9.55

**KNOWN:** Dimensions and temperature of beer can in refrigerator compartment.

**FIND:** Orientation which maximizes cooling rate.

**SCHEMATIC:**

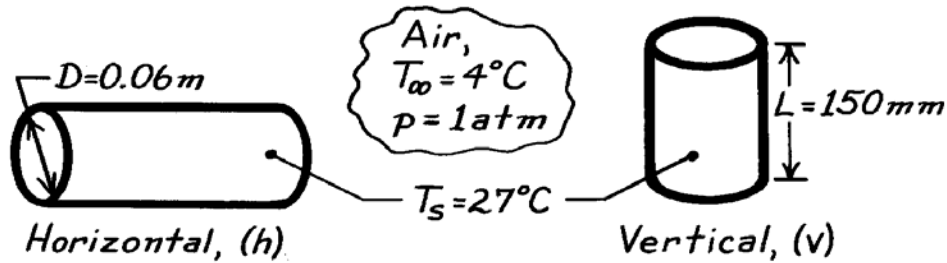

**ASSUMPTIONS:** (1) End effects are negligible, (2) Compartment air is quiescent, (3) Constant properties.

**PROPERTIES:** Table A-4, Air ( $T_f = 288.5\text{K}$ , 1 atm):  $\nu = 14.87 \times 10^{-6} \text{m}^2/\text{s}$ ,  $k = 0.0254 \text{W/m}\cdot\text{K}$ ,  $\alpha = 21.0 \times 10^{-6} \text{m}^2/\text{s}$ ,  $\text{Pr} = 0.71$ ,  $\beta = 1/T_f = 3.47 \times 10^{-3} \text{K}^{-1}$ .

**ANALYSIS:** The ratio of cooling rates may be expressed as

$$\frac{q_v}{q_h} = \frac{\bar{h}_v \pi D L (T_s - T_{\infty})}{\bar{h}_h \pi D L (T_s - T_{\infty})} = \frac{\bar{h}_v}{\bar{h}_h}.$$

For the *vertical* surface, find

$$\text{Ra}_L = \frac{g\beta(T_s - T_{\infty})L^3}{\nu\alpha} = \frac{9.8 \text{m/s}^2 \times 3.47 \times 10^{-3} \text{K}^{-1} (23^{\circ}\text{C})}{(14.87 \times 10^{-6} \text{m}^2/\text{s})(21 \times 10^{-6} \text{m}^2/\text{s})} L^3 = 2.5 \times 10^9 L^3$$

$$\text{Ra}_L = 2.5 \times 10^9 (0.15)^3 = 8.44 \times 10^6,$$

and using the correlation of Eq. 9.26, 
$$\bar{\text{Nu}}_L = \left\{ 0.825 + \frac{0.387 (8.44 \times 10^6)^{1/6}}{[1 + (0.492/0.71)^{9/16}]^{8/27}} \right\}^2 = 29.7.$$

Hence 
$$\bar{h}_L = \bar{h}_v = \bar{\text{Nu}}_L \frac{k}{L} = 29.7 \frac{0.0254 \text{W/m}\cdot\text{K}}{0.15\text{m}} = 5.03 \text{W/m}^2 \cdot \text{K}.$$

For the *horizontal* surface, find 
$$\text{Ra}_D = \frac{g\beta(T_s - T_{\infty})D^3}{\nu\alpha} = 2.5 \times 10^9 (0.06)^3 = 5.4 \times 10^5$$

and using the correlation of Eq. 9.34, 
$$\bar{\text{Nu}}_D = \left\{ 0.60 + \frac{0.387 (5.4 \times 10^5)^{1/6}}{[1 + (0.559/0.71)^{9/16}]^{8/27}} \right\}^2 = 12.24$$

$$\bar{h}_D = \bar{h}_h = \bar{\text{Nu}}_D \frac{k}{D} = 12.24 \frac{0.0254 \text{W/m}\cdot\text{K}}{0.06\text{m}} = 5.18 \text{W/m}^2 \cdot \text{K}.$$

Hence 
$$\frac{q_v}{q_h} = \frac{5.03}{5.18} = 0.97.$$

<

**COMMENTS:** In view of the uncertainties associated with Eqs. 9.26 and 9.34 and the neglect of end effects, the above result is inconclusive. The cooling rates are approximately the same.



## PROBLEM 9.56

**KNOWN:** A long uninsulated steam line with a diameter of 89 mm and surface emissivity of 0.8 transports steam at 200°C and is exposed to atmospheric air and large surroundings at an equivalent temperature of 20°C.

**FIND:** (a) The heat loss per unit length for a calm day when the ambient air temperature is 20°C; (b) The heat loss on a breezy day when the wind speed is 8 m/s; and (c) For the conditions of part (a), calculate the heat loss with 20-mm thickness of insulation ( $k = 0.08 \text{ W/m}\cdot\text{K}$ ). Would the heat loss change significantly with an appreciable wind speed?

**SCHEMATIC:**

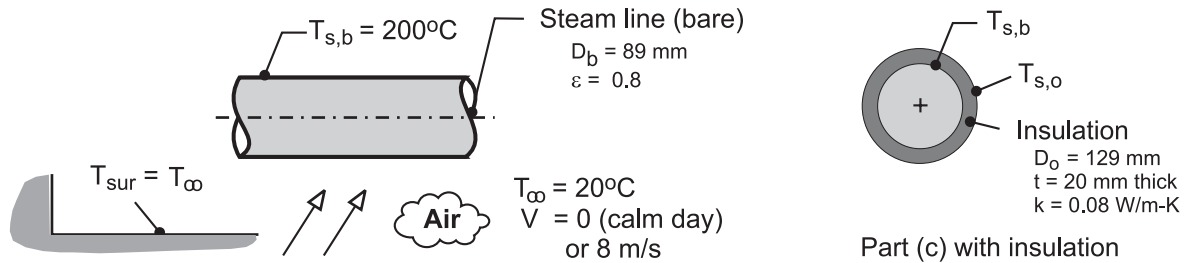

**ASSUMPTIONS:** (1) Steady-state conditions, (2) Calm day corresponds to quiescent ambient conditions, (3) Breeze is in crossflow over the steam line, (4) Atmospheric air and large surroundings are at the same temperature; and (5) Emissivity of the insulation surface is 0.8.

**PROPERTIES:** Table A-4, Air ( $T_f = (T_s + T_{\infty})/2 = 383 \text{ K}$ , 1 atm):  $\nu = 2.454 \times 10^{-5} \text{ m}^2/\text{s}$ ,  $k = 0.03251 \text{ W/m}\cdot\text{K}$ ,  $\alpha = 3.544 \times 10^{-5} \text{ m}^2/\text{s}$ ,  $\text{Pr} = 0.693$ .

**ANALYSIS:** (a) The heat loss per unit length from the pipe by convection and radiation exchange with the surroundings is

$$q'_b = q'_{cv} + q'_{rad}$$

$$q'_b = \bar{h}_D P_b (T_{s,b} - T_{\infty}) + \varepsilon P_b \sigma (T_{s,b}^4 - T_{\infty}^4) \quad P_b = \pi D_b \quad (1,2)$$

where  $D_b$  is the diameter of the bare pipe. Using the Churchill-Chu correlation, Eq. 9.34, for free convection from a horizontal cylinder, estimate  $\bar{h}_D$

$$\overline{\text{Nu}}_D = \frac{\bar{h}_D D_b}{k} = \left\{ 0.60 + \frac{0.387 \text{ Ra}_D^{1/6}}{\left[ 1 + (0.559/\text{Pr})^{9/16} \right]^{8/27}} \right\}^2 \quad (3)$$

where properties are evaluated at the film temperature,  $T_f = (T_s + T_{\infty})/2$  and

$$\text{Ra}_D = \frac{g\beta(T_s - T_{\infty})D_b^3}{\nu\alpha} \quad (4)$$

Substituting numerical values, find for the *bare* steam line

$\text{Ra}_D$	$\overline{\text{Nu}}_D$	$\bar{h}_D \text{ (W/m}^2\cdot\text{K)}$	$q'_{cv} \text{ (W/m)}$	$q'_{rad} \text{ (W/m)}$	$q'_b \text{ (W/m)}$	<
$3.73 \times 10^6$	21.1	7.71	388	541	929	

Continued ...

**PROBLEM 9.56 (Cont.)**

(b) For forced convection conditions with  $V = 8$  m/s, use the Churchill-Bernstein correlation, Eq. 7.54,

$$\overline{\text{Nu}}_D = \frac{\bar{h}_D D_b}{k} = 0.3 + \frac{0.62 \text{Re}_D^{1/2} \text{Pr}^{1/3}}{\left[1 + (0.4/\text{Pr})^{2/3}\right]^{1/4}} \left[1 + \left(\frac{\text{Re}_D}{282,000}\right)^{5/8}\right]^{4/5}$$

where  $\text{Re}_D = VD/v$ . Substituting numerical values, find

$\text{Re}_D$	$\overline{\text{Nu}}_D$	$\bar{h}_{D,b}$ (W/m <sup>2</sup> ·K)	$q'_{cv}$ (W/m)	$q'_{rad}$ (W/m)	$q'_b$ (W/m)
$2.90 \times 10^4$	97.7	35.7	1800	541	2340

(c) With 20-mm thickness insulation, and for the calm-day condition, the heat loss per unit length is

$$q'_{ins} = (T_{s,o} - T_\infty) / R'_{tot} \quad (1)$$

$$R'_t = R'_{ins} + [1/R'_{cv} + 1/R'_{rad}]^{-1} \quad (2)$$

where the thermal resistance of the insulation from Eq. 3.33 is

$$R'_{ins} = \ell \ln(D_o / D_b) / [2\pi k] \quad (3)$$

and the convection and radiation thermal resistances are

$$R'_{cv} = 1 / (\bar{h}_{D,o} \pi D_o) \quad (4)$$

$$R'_{rad} = 1 / (\bar{h}_{rad} \pi D_o) \quad \bar{h}_{rad,o} = \varepsilon \sigma (T_{s,o} + T_\infty) (T_{s,o}^2 + T_\infty^2) \quad (5,6)$$

The outer surface temperature of the insulation,  $T_{s,o}$ , can be determined by an energy balance on the *surface node* of the thermal circuit.

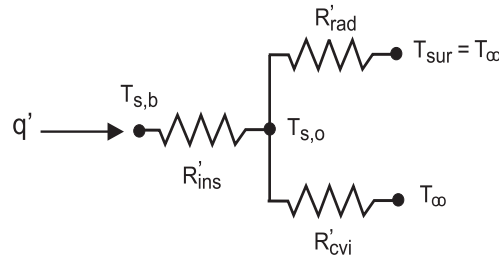

$$\frac{T_{s,b} - T_{s,o}}{R'_{ins}} = \frac{T_{s,o} - T_\infty}{[1/R'_{cv} + 1/R'_{rad}]^{-1}}$$

Substituting numerical values with  $D_{b,o} = 129$  mm, find the following results.

$R'_{ins} = 0.7384$ m·K/W	$\bar{h}_{D,o} = 5.30$ W/m <sup>2</sup> ·K
$R'_{cv} = 0.4655$ K/W	$\bar{h}_{rad} = 5.65$ W/m <sup>2</sup> ·K
$R'_{rad} = 0.4371$ K/W	$q'_{ins} = 187$ W/m
$T_{s,o} = 62.1^\circ\text{C}$	

Continued ...

### PROBLEM 9.56 (Cont.)

**COMMENTS:** (1) For the calm-day conditions, the heat loss by radiation exchange is 58% of the total loss. Using a reflective shield (say,  $\varepsilon = 0.1$ ) on the outer surface could reduce the heat loss by 50%.

(2) The effect of a 8-m/s breeze over the steam line is to increase the heat loss by more than a factor of two above that for a calm day. The heat loss by radiation exchange is approximately 25% of the total loss.

(3) The effect of the 20-mm thickness insulation is to reduce the heat loss to 20% the rate by free convection or to 9% the rate on the breezy day. From the results of part (c), note that the insulation resistance is nearly 3 times that due to the combination of the convection and radiation process thermal resistances. The effect of increased wind speed is to reduce  $R'_{cv}$ , but since  $R'_{ins}$  is the dominant resistance, the effect will not be very significant.

(4) The convection correlation models in *IHT* are especially useful for applications such as the present one to eliminate the tediousness of evaluating properties and performing the calculations. However, it is essential that you have experiences in hand calculations with the correlations before using the software.

### PROBLEM 9.57

**KNOWN:** Length and diameter of tube submerged in paraffin of prescribed dimensions. Properties of paraffin. Inlet temperature, flow rate and properties of water in the tube.

**FIND:** (a) Water outlet temperature, (b) Heat rate, (c) Time for complete melting.

**SCHEMATIC:**

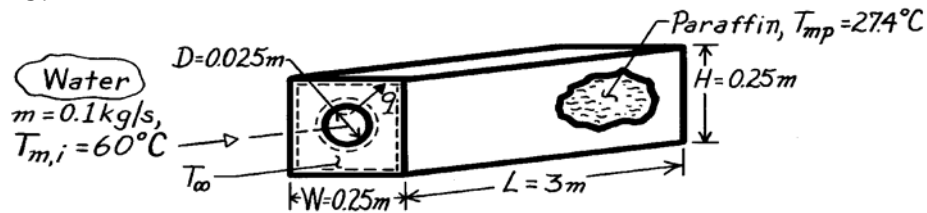

**ASSUMPTIONS:** (1) Water is incompressible liquid with negligible viscous dissipation, (2) Constant properties for water and paraffin, (3) Negligible tube wall conduction resistance, (4) Free convection at outer surface associated with horizontal cylinder in an infinite quiescent medium, (5) Negligible heat loss to surroundings, (6) Fully developed flow in tube.

**PROPERTIES:** Water (given):  $c_p = 4185 \text{ J/kg}\cdot\text{K}$ ,  $k = 0.653 \text{ W/m}\cdot\text{K}$ ,  $\mu = 467 \times 10^{-6} \text{ kg/s}\cdot\text{m}$ ,  $\text{Pr} = 2.99$ ; Paraffin (given):  $T_{mp} = 27.4^\circ\text{C}$ ,  $h_{sf} = 244 \text{ kJ/kg}$ ,  $k = 0.15 \text{ W/m}\cdot\text{K}$ ,  $\beta = 8 \times 10^{-4} \text{ K}^{-1}$ ,  $\rho = 770 \text{ kg/m}^3$ ,  $\nu = 5 \times 10^{-6} \text{ m}^2/\text{s}$ ,  $\alpha = 8.85 \times 10^{-8} \text{ m}^2/\text{s}$ .

**ANALYSIS:** (a) The overall heat transfer coefficient is

$$\frac{1}{U} = \frac{1}{h_i} + \frac{1}{h_o}$$

To estimate  $h_i$ , find  $\text{Re}_D = \frac{4\dot{m}}{\pi D \mu} = \frac{4 \times 0.1 \text{ kg/s}}{\pi \times 0.025 \text{ m} \times 467 \times 10^{-6} \text{ kg/s}\cdot\text{m}} = 10,906$

and noting the flow is turbulent, use the Dittus-Boelter correlation

$$\text{Nu}_D = 0.023 \text{Re}_D^{4/5} \text{Pr}^{0.3} = 0.023(10,906)^{4/5} (2.99)^{0.3} = 54.3$$

$$h_i = \frac{\text{Nu}_D k}{D} = \frac{54.3 \times 0.653 \text{ W/m}\cdot\text{K}}{0.025 \text{ m}} = 1418 \text{ W/m}^2 \cdot \text{K}$$

To estimate  $h_o$ , find

$$\text{Ra}_D = \frac{g\beta(T_s - T_\infty)D^3}{\nu\alpha} = \frac{(9.8 \text{ m/s}^2)8 \times 10^{-4} \text{ K}^{-1}(55 - 27.4) \text{ K}(0.025 \text{ m})^3}{5 \times 10^{-6} \text{ m}^2/\text{s} \times 8.85 \times 10^{-8} \text{ m}^2/\text{s}}$$

$$\text{Ra}_D = 7.64 \times 10^6$$

and using the correlation of Eq. 9.34,  $\overline{\text{Nu}}_D = \left\{ 0.60 + \frac{0.387 \text{Ra}_D^{1/6}}{\left[ 1 + (0.559/\text{Pr})^{9/16} \right]^{8/27}} \right\}^2 = 35.0$

$$h_o = \overline{\text{Nu}}_D \frac{k}{D} = 35.0 \frac{0.15 \text{ W/m}\cdot\text{K}}{0.025 \text{ m}} = 210 \text{ W/m}^2 \cdot \text{K}$$

Alternatively, using the correlation of Eq. 9.33,

Continued ...

**PROBLEM 9.57 (Cont.)**

$$\text{Nu}_D = C\text{Ra}_D^n \text{ with } C = 0.48, n = 0.25 \quad \text{Nu}_D = 25.2$$

$$h_o = 25.2 \frac{0.15 \text{ W/m} \cdot \text{K}}{0.025 \text{ m}} = 151 \text{ W/m}^2 \cdot \text{K}.$$

The significant difference in  $h_o$  values for the two correlations may be due to difficulties associated with high Pr applications of one or both correlations. Continuing with the result from Eq. 9.34,

$$\frac{1}{\bar{U}} = \frac{1}{h_i} + \frac{1}{h_o} = \frac{1}{1418} + \frac{1}{210} = 5.467 \times 10^{-3} \text{ m}^2 \cdot \text{K} / \text{W}$$

$$\bar{U} = 183 \text{ W/m}^2 \cdot \text{K}.$$

Using Eq. 8.45a, find

$$\frac{T_\infty - T_{m,o}}{T_\infty - T_{m,i}} = \exp\left(-\frac{\pi D L \bar{U}}{\dot{m} c_p}\right) = \exp\left(-\frac{\pi \times 0.025 \text{ m} \times 3 \text{ m}}{0.1 \text{ kg/s} \times 4185 \text{ J/kg} \cdot \text{K}} 183 \frac{\text{W}}{\text{m}^2 \cdot \text{K}}\right)$$

$$T_{m,o} = T_\infty - (T_\infty - T_{m,i}) 0.902 = [27.4 - (27.4 - 60) 0.902]^\circ\text{C}$$

$$T_{m,o} = 56.8^\circ\text{C}. \quad <$$

(b) From an energy balance, the heat rate is

$$q = \dot{m} c_p (T_{m,i} - T_{m,o}) = 0.1 \text{ kg/s} \times 4185 \text{ J/kg} \cdot \text{K} (60 - 56.8) \text{ K} = 1335 \text{ W} \quad <$$

or using the rate equation,

$$q = \bar{U} A \Delta T_{\ell m} = 183 \text{ W/m}^2 \cdot \text{K} \pi (0.025 \text{ m}) 3 \text{ m} \frac{(60 - 27.4) \text{ K} - (56.8 - 27.4) \text{ K}}{\ln \frac{60 - 27.4}{56.8 - 27.4}}$$

$$q = 1335 \text{ W}.$$

(c) Applying an energy balance to a control volume about the paraffin,

$$E_{\text{in}} = \Delta E_{\text{st}}$$

$$q \cdot t = \rho V h_{\text{sf}} = \rho L \left[ WH - \pi D^2 / 4 \right] h_{\text{sf}}$$

$$t = \frac{770 \text{ kg/m}^3 \times 3 \text{ m}}{1335 \text{ W}} \left[ (0.25 \text{ m})^2 - \frac{\pi}{4} (0.025 \text{ m})^2 \right] 2.44 \times 10^5 \text{ J/kg}$$

$$t = 2.618 \times 10^4 \text{ s} = 7.27 \text{ h}. \quad <$$

**COMMENTS:** (1) The value of  $\bar{h}_o$  is overestimated by assuming an infinite quiescent medium. The fact that the paraffin is enclosed will increase the resistance due to free convection and hence decrease  $q$  and increase  $t$ .

(2) Using  $\bar{h}_o = 151 \text{ W/m}^2 \cdot \text{K}$  results in  $\bar{U} = 136 \text{ W/m}^2 \cdot \text{K}$ ,  $T_{m,o} = 57.6^\circ\text{C}$ ,  $q = 1009 \text{ W}$  and  $t = 9.62 \text{ h}$ .

### PROBLEM 9.58

**KNOWN:** Horizontal tube, 12.5mm diameter, with surface temperature 240°C located in room with an air temperature 20°C.

**FIND:** Heat transfer rate per unit length of tube due to convection.

**SCHEMATIC:**

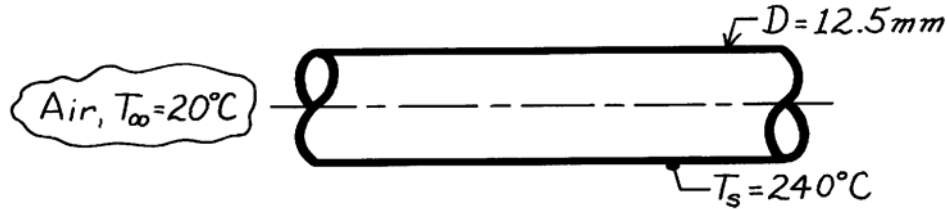

**ASSUMPTIONS:** (1) Ambient air is quiescent, (2) Surface radiation effects are not considered.

**PROPERTIES:** Table A-4, Air ( $T_f = 400\text{K}$ , 1 atm):  $\nu = 26.41 \times 10^{-6} \text{ m}^2/\text{s}$ ,  $k = 0.0338 \text{ W/m}\cdot\text{K}$ ,  $\alpha = 38.3 \times 10^{-6} \text{ m}^2/\text{s}$ ,  $\text{Pr} = 0.690$ ,  $\beta = 1/T_f = 2.5 \times 10^{-3} \text{ K}^{-1}$ .

**ANALYSIS:** The heat rate from the tube, per unit length of the tube, is

$$q' = \bar{h} \pi D (T_s - T_\infty)$$

where  $\bar{h}$  can be estimated from the correlation, Eq. 9.34,

$$\overline{\text{Nu}}_D = \left\{ 0.60 + \frac{0.387 \text{Ra}_D^{1/6}}{\left[ 1 + (0.559/\text{Pr})^{9/16} \right]^{8/27}} \right\}^2$$

From Eq. 9.25,

$$\text{Ra}_D = \frac{g\beta(T_s - T_\infty)D^3}{\nu\alpha} = \frac{9.8 \text{ m/s}^2 \times 2.5 \times 10^{-3} \text{ K}^{-1} (240 - 20) \text{ K} \times (12.5 \times 10^{-3} \text{ m})^3}{26.41 \times 10^{-6} \text{ m}^2/\text{s} \times 38.3 \times 10^{-6} \text{ m}^2/\text{s}} = 10,410.$$

$$\text{Hence, } \overline{\text{Nu}}_D = \left\{ 0.60 + \frac{0.387 (10,410)^{1/6}}{\left[ 1 + (0.559/0.690)^{9/16} \right]^{8/27}} \right\}^2 = 4.40$$

$$\bar{h} = \frac{k}{D} \overline{\text{Nu}}_D = \frac{0.0338 \text{ W/m}\cdot\text{K}}{12.5 \times 10^{-3} \text{ m}} \times 4.40 = 11.9 \text{ W/m}^2 \cdot \text{K}.$$

The heat rate is

$$q' = 11.9 \text{ W/m}^2 \cdot \text{K} \times \pi (12.5 \times 10^{-3} \text{ m}) (240 - 20) \text{ K} = 103 \text{ W/m}. \quad <$$

**COMMENTS:** Heat loss rate by radiation, assuming an emissivity of 1.0 for the surface, is

$$q'_{\text{rad}} = \varepsilon P \sigma (T_s^4 - T_\infty^4) = 1 \times \pi (12.5 \times 10^{-3} \text{ m}) \times 5.67 \times 10^{-8} \frac{\text{W}}{\text{m}^2 \cdot \text{K}^4} \left[ (240 + 273)^4 - (20 + 273)^4 \right] \text{ K}^4$$

$$q'_{\text{rad}} = 138 \text{ W/m}.$$

Note that  $P = \pi D$ . Note also this estimate assumes the surroundings are at ambient air temperature. In this instance,  $q'_{\text{rad}} > q'_{\text{conv}}$ .

## PROBLEM 9.59

**KNOWN:** Insulated steam tube exposed to atmospheric air and surroundings at 25°C.

**FIND:** (a) Heat transfer rate by free convection to the room, per unit length of the tube; effect on quality,  $x$ , at outlet of 30 m length of tube; (b) Effect of radiation on heat transfer and quality of outlet flow; (c) Effect of emissivity and insulation thickness on heat rate.

**SCHEMATIC:**

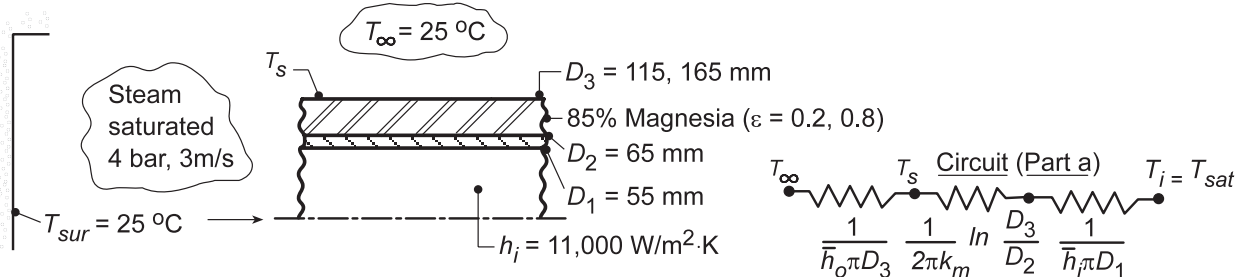

**ASSUMPTIONS:** (1) Ambient air is quiescent, (2) Negligible surface radiation (part a), (3) Tube wall resistance negligible.

**PROPERTIES:** Steam tables, steam (sat., 4 bar):  $i_f = 566$  kJ/kg,  $T_{sat} = 416$  K,  $i_g = 2727$  kJ/kg,  $i_{fg} = h_{fg} = 2160$  kJ/kg,  $v_g = 0.476$  m<sup>3</sup>/kg; Table A.3, magnesia, 85% (310 K):  $k_m = 0.051$  W/m·K; Table A.4, air (assume  $T_s = 60^\circ\text{C}$ ,  $T_f = (60 + 25)^\circ\text{C}/2 = 315$  K, 1 atm):  $\nu = 17.4 \times 10^{-6}$  m<sup>2</sup>/s,  $k = 0.0274$  W/m·K,  $\alpha = 24.7 \times 10^{-6}$  m<sup>2</sup>/s,  $Pr = 0.705$ ,  $T_f = 1/315$  K =  $3.17 \times 10^{-3}$  K<sup>-1</sup>.

**ANALYSIS:** (a) The heat rate per unit length of the tube (see sketch) is given as,

$$q' = \frac{T_i - T_\infty}{R'_t} \quad \text{where} \quad \frac{1}{R'_t} = \left[ \frac{1}{\bar{h}_o \pi D_3} + \frac{1}{2\pi k_m} \ln \frac{D_3}{D_2} + \frac{1}{\bar{h}_i \pi D_1} \right]^{-1} \quad (1,2)$$

To estimate  $\bar{h}_o$ , we have assumed  $T_s \approx 60^\circ\text{C}$  in order to calculate  $Ra_D$  from Eq. 9.25,

$$Ra_D = \frac{g\beta(T_s - T_\infty)D_3^3}{\nu\alpha} = \frac{9.8 \text{ m/s}^2 \times 3.17 \times 10^{-3} \text{ K}^{-1} (60 - 25) \text{ K} (0.115 \text{ m})^3}{17.4 \times 10^{-6} \text{ m}^2/\text{s} \times 24.7 \times 10^{-6} \text{ m}^2/\text{s}} = 3.85 \times 10^6.$$

The appropriate correlation is Eq. 9.34; find

$$\bar{Nu}_D = \left\{ 0.60 + \frac{0.387(Ra_D)^{1/6}}{\left[ 1 + (0.559/Pr)^{9/16} \right]^{8/27}} \right\}^2 = \left\{ 0.60 + \frac{0.387(3.85 \times 10^6)^{1/6}}{\left[ 1 + (0.559/0.705)^{9/16} \right]^{8/27}} \right\}^2 = 21.4$$

$$\bar{h}_o = \frac{k}{D_3} \bar{Nu}_D = \frac{0.0274 \text{ W/m} \cdot \text{K}}{0.115 \text{ m}} \times 21.4 = 5.09 \text{ W/m}^2 \cdot \text{K}.$$

Substituting numerical values into Eq. (2), find

$$\frac{1}{R'_t} = \left[ \frac{1}{5.09 \text{ W/m}^2 \cdot \text{K} \times \pi \times 0.115 \text{ m}} + \frac{1}{2\pi \times 0.051 \text{ W/m} \cdot \text{K}} \ln \frac{115}{65} + \frac{1}{11,000 \text{ W/m}^2 \cdot \text{K} \times \pi \times 0.055 \text{ m}} \right]^{-1} = 0.430 \text{ W/m} \cdot \text{K}$$

and from Eq. (1),  $q' = 0.430 \text{ W/m} \cdot \text{K} (416 - 298) \text{ K} = 50.8 \text{ W/m}$  <

Continued...

### PROBLEM 9.59 (Cont.)

We need to verify that the assumption of  $T_s = 60^\circ\text{C}$  is reasonable. From the thermal circuit,

$$T_s = T_\infty + q'/\bar{h}_o \pi D_3 = 25^\circ\text{C} + 50.8 \text{ W/m} / \left( 5.09 \text{ W/m}^2 \cdot \text{K} \times \pi \times 0.115 \text{ m} \right) = 53^\circ\text{C}.$$

Another calculation using  $T_s = 53^\circ\text{C}$  would be appropriate for a more precise result.

Assuming  $q'$  is constant, the enthalpy of the steam at the outlet ( $L = 30 \text{ m}$ ),  $i_2$ , is

$$i_2 = i_1 - q' \cdot L/\dot{m} = 2727 \text{ kJ/kg} - 50.8 \text{ W/m} \times 30 \text{ m} / 0.015 \text{ kg/s} = 2625 \text{ kJ/kg}$$

where  $\dot{m} = \rho_g A_c u_m$  with  $\rho_g = 1/v_g$  and  $A_c = \pi D_1^2/4$ . For negligible pressure drop,

$$x = (i_2 - i_f)/i_{fg} = (2625 - 566) \text{ kJ/kg} / (2160 \text{ kJ/kg}) = 0.953. \quad <$$

(b) With radiation, we first determine  $T_s$  by performing an energy balance at the outer surface, where

$$q'_i = q'_{\text{conv},o} + q'_{\text{rad}}$$

$$\frac{T_i - T_s}{R'_i} = \bar{h}_o \pi D_3 (T_s - T_\infty) + \pi D_3 \varepsilon \sigma (T_s^4 - T_{\text{sur}}^4)$$

and

$$R'_i = \frac{1}{h_i \pi D_1} + \frac{1}{2\pi k_m} \ln \frac{D_3}{D_2}$$

From knowledge of  $T_s$ ,  $q'_i = (T_i - T_s)/R'_i$  may then be determined. Using the *Correlations* and *Properties* Tool Pads of IHT to determine  $\bar{h}_o$  and the properties of air evaluated at  $T_f = (T_s + T_\infty)/2$ , the following results are obtained.

	Condition	$T_s$ ( $^\circ\text{C}$ )	$q'_i$ (W/m)	x	
	$\varepsilon = 0.8, D_3 = 115 \text{ mm}$	41.8	56.9	0.948	<
(c)	$\varepsilon = 0.8, D_3 = 165 \text{ mm}$	33.7	37.6	0.966	<
	$\varepsilon = 0.2, D_3 = 115 \text{ mm}$	49.4	52.6	0.952	<
	$\varepsilon = 0.2, D_3 = 165 \text{ mm}$	38.7	35.9	0.967	<

**COMMENTS:** Clearly, a significant reduction in heat loss may be realized by increasing the insulation thickness. Although  $T_s$ , and hence  $q'_{\text{conv},o}$ , increases with decreasing  $\varepsilon$ , the reduction in  $q'_{\text{rad}}$  is more than sufficient to reduce the heat loss.



### PROBLEM 9.60

**KNOWN:** Dissipation rate of an electrical cable suspended in air.

**FIND:** Surface temperature of the cable,  $T_s$ .

**SCHEMATIC:**

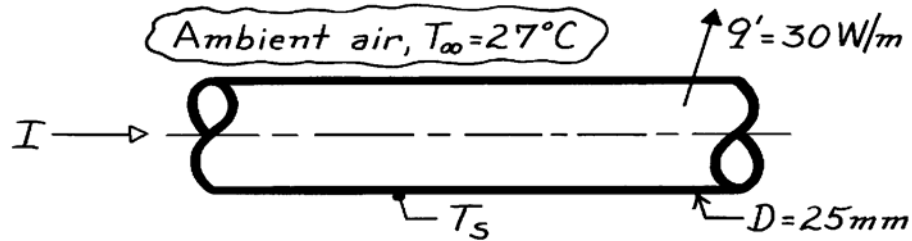

**ASSUMPTIONS:** (1) Quiescent air, (2) Cable in horizontal position, (3) Negligible radiation exchange.

**PROPERTIES:** Table A-4, Air ( $T_f = (T_s + T_\infty)/2 = 325\text{K}$ , based upon initial estimate for  $T_s$ , 1 atm):  
 $\nu = 18.41 \times 10^{-6}\ \text{m}^2/\text{s}$ ,  $k = 0.0282\ \text{W/m}\cdot\text{K}$ ,  $\alpha = 26.2 \times 10^{-6}\ \text{m}^2/\text{s}$ ,  $\text{Pr} = 0.704$ .

**ANALYSIS:** From the rate equation on a unit length basis, the surface temperature is

$$T_s = T_\infty + q' / \pi D \bar{h}$$

where  $\bar{h}$  is estimated by an appropriate correlation. Since such a calculation requires knowledge of  $T_s$ , an iteration procedure is required. Begin by assuming  $T_s = 77^\circ\text{C}$  and calculated  $\text{Ra}_D$ ,

$$\text{Ra}_D = g\beta\Delta T D^3 / \nu\alpha \quad \text{where } \Delta T = T_s - T_\infty \quad \text{and} \quad T_f = (T_s + T_\infty)/2 \quad (1,2,3)$$

For air,  $\beta = 1/T_f$ , and substituting numerical values,

$$\text{Ra}_D = 9.8 \frac{\text{m}}{\text{s}^2} (1/325\text{K})(77 - 27)\text{K} (0.025\text{m})^3 / 18.41 \times 10^{-6} \frac{\text{m}^2}{\text{s}} \times 26.2 \times 10^{-6} \frac{\text{m}^2}{\text{s}} = 4.884 \times 10^4.$$

Using the Churchill-Chu relation, find  $\bar{h}$ .

$$\overline{\text{Nu}}_D = \frac{\bar{h}D}{k} = \left\{ 0.60 + \frac{0.387 \text{Ra}_D^{1/6}}{\left[ 1 + (0.559/\text{Pr})^{9/16} \right]^{8/27}} \right\}^2 \quad (4)$$

$$\bar{h} = \frac{0.0282\ \text{W/m}\cdot\text{K}}{0.025\text{m}} \left\{ 0.60 + \frac{0.387 (4.884 \times 10^4)^{1/6}}{\left[ 1 + (0.559/0.704)^{9/16} \right]^{8/27}} \right\}^2 = 7.28\ \text{W/m}^2 \cdot \text{K}.$$

Substituting numerical values into Eq. (1), the calculated value for  $T_s$  is

$$T_s = 27^\circ\text{C} + (30\ \text{W/m}) / \pi \times 0.025\text{m} \times 7.28\ \text{W/m}^2 \cdot \text{K} = 79.5^\circ\text{C}.$$

This value is very close to the assumed value ( $77^\circ\text{C}$ ), but an iteration with a new value of  $79^\circ\text{C}$  is warranted. Using the same property values, find for this iteration:

$$\text{Ra}_D = 5.08 \times 10^4 \quad \bar{h} = 7.35\ \text{W/m}^2 \cdot \text{K} \quad T_s = 79^\circ\text{C}. \quad <$$

We conclude that  $T_s = 79^\circ\text{C}$  is a good estimate for the surface temperature.

**COMMENTS:** Recognize that radiative exchange is likely to be significant and would have the effect of reducing the estimate for  $T_s$ .

### PROBLEM 9.61

**KNOWN:** Dissipation rate of an immersion heater in a large tank of water.

**FIND:** Surface temperature in water and, if accidentally operated, in air.

**SCHEMATIC:**

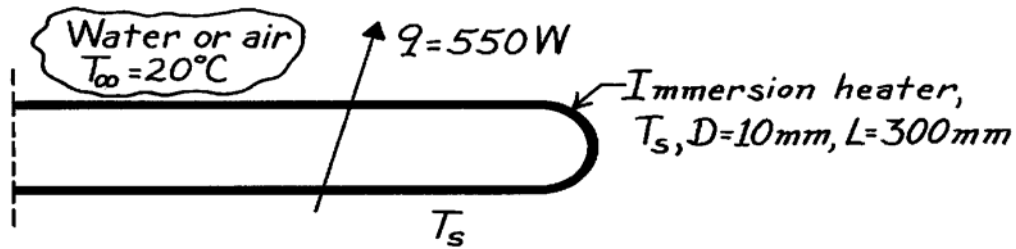

**ASSUMPTIONS:** (1) Quiescent ambient fluid, (2) Negligible radiative exchange.

**PROPERTIES:** Table A-6, Water and Table A-4, Air:

	T(K)	$k \cdot 10^3$ (W/m·K)	$\nu \cdot 10^7$ ( $\mu/\rho, \text{m}^2/\text{s}$ )	$\alpha \cdot 10^7$ ( $k/\rho c_p, \text{m}^2/\text{s}$ )	Pr	$\beta \cdot 10^6$ ( $\text{K}^{-1}$ )
Water	315	634	6.25	1.531	4.16	400.4
Air	1500	100	2400	3500	0685	666.7

**ANALYSIS:** From the rate equation, the surface temperature,  $T_s$ , is

$$T_s = T_\infty + q / (\pi D L \bar{h}) \quad (1)$$

where  $\bar{h}$  is estimated by an appropriate correlation. Since such a calculation requires knowledge of  $T_s$ , an iteration procedure is required. Begin by assuming for *water* that  $T_s = 64^\circ\text{C}$  such that  $T_f = 315\text{K}$ . Calculate the Rayleigh number,

$$\text{Ra}_D = \frac{g\beta\Delta T D^3}{\nu\alpha} = \frac{9.8\text{m/s}^2 \times 400.4 \times 10^{-6} \text{K}^{-1} (64 - 20) \text{K} (0.010\text{m})^3}{6.25 \times 10^{-7} \text{m}^2/\text{s} \times 1.531 \times 10^{-7} \text{m}^2/\text{s}} = 1.804 \times 10^6. \quad (2)$$

Using the Churchill-Chu relation, find

$$\overline{\text{Nu}}_D = \frac{\bar{h}D}{k} = \left\{ 0.60 + \frac{0.387 \text{Ra}_D^{1/6}}{\left[ 1 + (0.559/\text{Pr})^{9/16} \right]^{8/27}} \right\}^2 \quad (3)$$

$$\bar{h} = \frac{0.634 \text{W/m}\cdot\text{K}}{0.01\text{m}} \left\{ 0.60 + \frac{0.387 (1.804 \times 10^6)^{1/6}}{\left[ 1 + (0.559/4.16)^{9/16} \right]^{8/27}} \right\}^2 = 1301 \text{W/m}^2 \cdot \text{K}.$$

Substituting numerical values into Eq. (1), the calculated value for  $T_s$  in *water* is

$$T_s = 20^\circ\text{C} + 550 \text{W} / \pi \times 0.010\text{m} \times 0.30\text{m} \times 1301 \text{W/m}^2 \cdot \text{K} = 64.8^\circ\text{C}. \quad <$$

Continued ...

### PROBLEM 9.61 (Cont.)

Our initial assumption of  $T_s = 64^\circ\text{C}$  is in excellent agreement with the calculated value.

With accidental operation in *air*, the heat transfer coefficient will be nearly a factor of 100 less.

Suppose  $\bar{h} \approx 25 \text{ W/m}^2 \cdot \text{K}$ , then from Eq. (1),  $T_s \approx 2360^\circ\text{C}$ . Very likely the heater will burn out.

Using air properties at  $T_f \approx 1500\text{K}$  and Eq. (2), find  $\text{Ra}_D = 1.815 \times 10^2$ . Using Eq. 9.33,

$\text{Nu}_D = C \text{Ra}_D^n$  with  $C = 0.85$  and  $n = 0.188$  from Table 9.1, find  $\bar{h} = 22.6 \text{ W/m}^2 \cdot \text{K}$ . Hence, our first estimate for the surface temperature in *air* was reasonable,

$$T_s \approx 2300^\circ\text{C}.$$

<

However, radiation exchange will be the dominant mode, and would reduce the estimate for  $T_s$ .

Generally such heaters could not withstand operating temperatures above  $1000^\circ\text{C}$  and safe operation in *air* is not possible.

## PROBLEM 9.62

**KNOWN:** Motor shaft of 20-mm diameter operating in ambient air at  $T_\infty = 27^\circ\text{C}$  with surface temperature  $T_s \leq 87^\circ\text{C}$ .

**FIND:** Convection coefficients and/or heat removal rates for different heat transfer processes: (a) For a rotating horizontal cylinder as a function of rotational speed 5000 to 15,000 rpm using the recommended correlation, (b) For free convection from a horizontal stationary shaft; investigate whether mixed free and forced convection effects for the range of rotational speeds in part (a) are significant using the recommended criterion; (c) For radiation exchange between the shaft having an emissivity of 0.8 and the surroundings also at ambient temperature,  $T_{\text{sur}} = T_\infty$ ; and (d) For cross flow of ambient air over the stationary shaft, required air velocities to remove the heat rates determined in part (a).

**SCHEMATIC:**

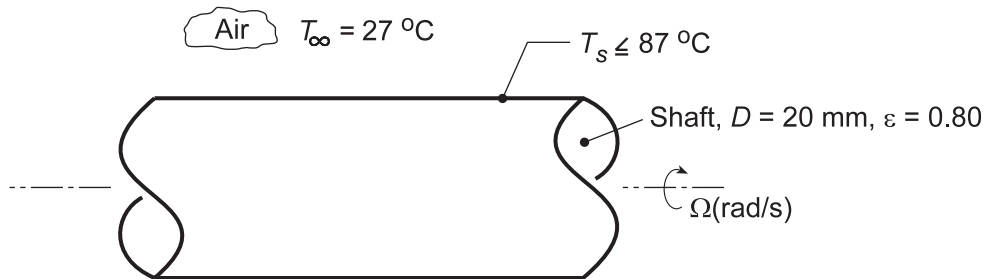

**ASSUMPTIONS:** (1) Steady-state conditions, (2) Shaft is horizontal with isothermal surface.

**PROPERTIES:** Table A.4, Air ( $T_f = (T_s + T_\infty)/2 = 330\text{ K}$ , 1 atm):  $\nu = 18.91 \times 10^{-6}\text{ m}^2/\text{s}$ ,  $k = 0.02852\text{ W/m}\cdot\text{K}$ ,  $\alpha = 26.94 \times 10^{-6}\text{ m}^2/\text{s}$ ,  $\text{Pr} = 0.7028$ ,  $\beta = 1/T_f$ .

**ANALYSIS:** (a) The recommended correlation for a horizontal rotating shaft is

$$\overline{\text{Nu}}_D = 0.133 \text{Re}_D^{2/3} \text{Pr}^{1/3} \quad \text{Re}_D < 4.3 \times 10^5 \quad 0.7 < \text{Pr} < 670$$

where the Reynolds number is

$$\text{Re}_D = \Omega D^2 / \nu$$

and  $\Omega$  (rad/s) is the rotational velocity. Evaluating properties at  $T_f = (T_s + T_\infty)/2$ , find for  $\omega = 5000$  rpm,

$$\text{Re}_D = (5000 \text{ rpm} \times 2\pi \text{ rad/rev} / 60 \text{ s/min}) (0.020 \text{ m})^2 / 18.91 \times 10^{-6} \text{ m}^2/\text{s} = 11,076$$

$$\overline{\text{Nu}}_D = 0.133 (11,076)^{2/3} (0.7028)^{1/3} = 58.75$$

$$\overline{h}_{D,\text{rot}} = \overline{\text{Nu}}_D k / D = 58.75 \times 0.02852 \text{ W/m}\cdot\text{K} / 0.020 \text{ m} = 83.8 \text{ W/m}^2 \cdot \text{K} \quad <$$

The heat rate per unit shaft length is

$$q'_{\text{rot}} = \overline{h}_{D,\text{rot}} (\pi D) (T_s - T_\infty) = 83.8 \text{ W/m}^2 \cdot \text{K} (\pi \times 0.020 \text{ m}) (87 - 27)^\circ\text{C} = 316 \text{ W/m} \quad <$$

The convection coefficient and heat rate as a function of rotational speed are shown in a plot below.

(b) For the stationary shaft condition, the free convection coefficient can be estimated from the Churchill-Chu correlation, Eq. (9.34) with

Continued...

**PROBLEM 9.62 (Cont.)**

$$Ra_D = \frac{g\beta\Delta TD^3}{\nu\alpha}$$

$$Ra_D = \frac{9.8 \text{ m/s}^2 (1/330\text{K})(87 - 27) \text{ K} (0.020\text{m})^3}{18.91 \times 10^{-6} \text{ m}^2/\text{s} \times 26.94 \times 10^{-6} \text{ m}^2/\text{s}} = 27,981$$

$$\overline{Nu}_D = \left\{ 0.60 + \frac{0.387 Ra_D^{1/6}}{\left[ 1 + (0.559/Pr)^{9/16} \right]^{8/27}} \right\}^2$$

$$\overline{Nu}_D = \left\{ 0.60 + \frac{0.387 (27,981)^{1/6}}{\left[ 1 + (0.559/0.7028)^{9/16} \right]^{8/27}} \right\}^2 = 5.61$$

$$\overline{h}_{D,fc} = \overline{Nu}_D k/D = 5.61 \times 0.02852 \text{ W/m} \cdot \text{K} / 0.020\text{m} = 8.00 \text{ W/m}^2 \cdot \text{K}$$

$$q'_{fc} = 8.00 \text{ W/m}^2 \cdot \text{K} (\pi \times 0.020\text{m})(87 - 27)^\circ \text{C} = 30.2 \text{ W/m}$$

<

Mixed free and forced convection effects may be significant if

$$Re_D < 4.7 \left( Gr_D^3 / Pr \right)^{0.137}$$

where  $Gr_D = Ra_D/Pr$ , find using results from above and in part (a) for  $\omega = 5000$  rpm,

$$11,076 \text{ ?} < 4.7 \left[ (27,981/0.7028)^3 / 0.7018 \right]^{0.137} = 383$$

We conclude that free convection effects are not significant for rotational speeds above 5000 rpm.

(c) Considering radiation exchange between the shaft and the surroundings,

$$h_{rad} = \varepsilon\sigma(T_s + T_{sur})(T_s^2 + T_{sur}^2)$$

$$h_{rad} = 0.8 \times 5.67 \times 10^{-8} \text{ W/m}^2 \cdot \text{K} (360 + 300) (360^2 + 300^2) \text{ K}^3 = 6.57 \text{ W/m}^2 \cdot \text{K}$$

<

and the heat rate by radiation exchange is

$$q'_{rad} = h_{rad} (\pi D)(T_s - T_{sur})$$

$$q'_{rad} = 6.57 \text{ W/m}^2 \cdot \text{K} (\pi \times 0.020\text{m})(87 - 27) \text{ K} = 24.8 \text{ W/m}$$

<

(d) For cross flow of ambient air at a velocity  $V$  over the shaft, the convection coefficient can be estimated using the Churchill-Bernstein correlation, Eq. 7.54, with

$$Re_{D,cf} = \frac{VD}{\nu}$$

$$\overline{Nu}_{D,cf} = \overline{h}_{D,cf} D/k = 0.3 + \frac{0.62 Re_{D,cf}^{1/2} Pr^{1/3}}{\left[ 1 + (0.4/Pr)^{2/3} \right]^{1/4}} \left[ 1 + \left( \frac{Re_{D,cf}}{282,000} \right)^{5/8} \right]^{4/5}$$

Continued...

### PROBLEM 9.62 (Cont.)

From the plot below (left) for the rotating shaft condition of part (a),  $\bar{h}_{D,rot}$  vs. rpm, note that the convection coefficient varies from approximately 75 to 175  $W/m^2 \cdot K$ . Using the *IHT Correlations Tool, Forced Convection, Cylinder*, which is based upon the above relations, the range of air velocities  $V$  required to achieve  $\bar{h}_{D,cf}$  in the range 75 to 175  $W/m^2 \cdot K$  was computed and is plotted below (right).

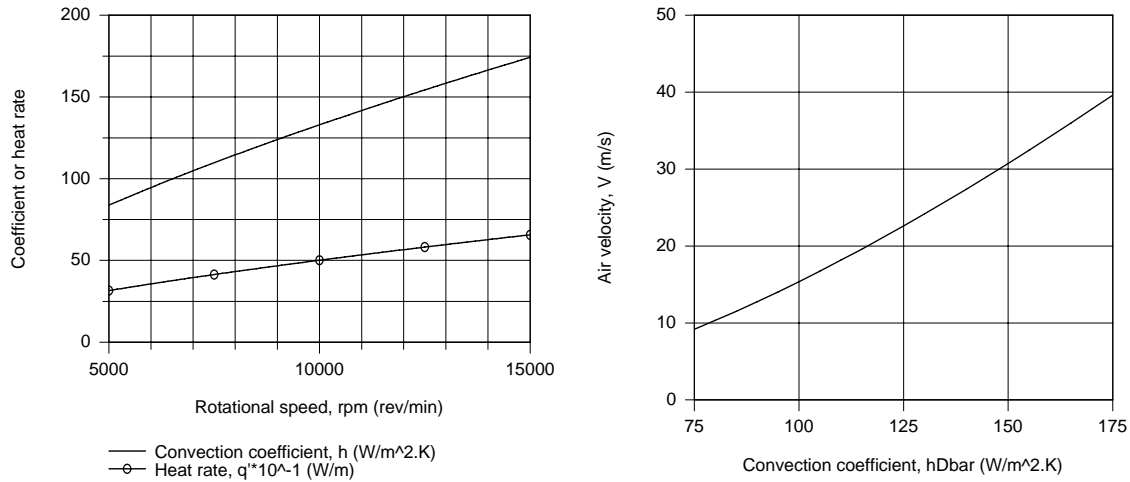

Note that the air cross-flow velocities are quite substantial in order to remove similar heat rates for the rotating shaft condition.

**COMMENTS:** We conclude for the rotational speed and surface temperature conditions, free convection effects are not significant. Further, radiation exchange, part (c) result, is less than 10% of the convection heat loss for the lowest rotational speed condition.

### PROBLEM 9.63

**KNOWN:** Horizontal pin fin of 6-mm diameter and 60-mm length fabricated from plain carbon steel ( $k = 57 \text{ W/m}\cdot\text{K}$ ,  $\varepsilon = 0.5$ ). Fin base maintained at  $T_b = 150^\circ\text{C}$ . Ambient air and surroundings at  $25^\circ\text{C}$ .

**FIND:** Fin heat rate,  $q_f$ , by two methods: (a) Analytical solution using average fin surface temperature of  $\bar{T}_s = 125^\circ\text{C}$  to estimate the free convection and linearized radiation coefficients; comment on sensitivity of fin heat rate to choice of  $\bar{T}_s$ ; and, (b) Finite-difference method when coefficients are based upon local temperatures, rather than an average fin surface temperature; compare result of the two solution methods.

**SCHEMATIC:**

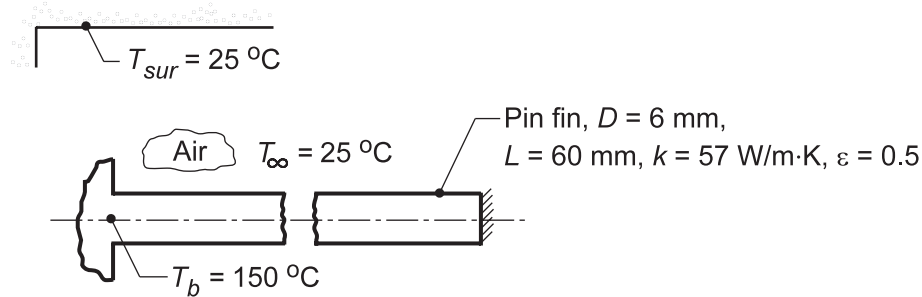

**ASSUMPTIONS:** (1) Steady-state conditions, (2) One-dimensional conduction in the pin fin, (3) Ambient air is quiescent and extensive, (4) Surroundings are large compared to the pin fin, and (5) Fin tip is adiabatic.

**PROPERTIES:** Table A.4, Air ( $T_f = (\bar{T}_s + T_\infty)/2 = 348 \text{ K}$ ):  $\nu = 20.72 \times 10^{-6} \text{ m}^2/\text{s}$ ,  $k = 0.02985 \text{ W/m}\cdot\text{K}$ ,  $\alpha = 29.60 \times 10^{-6} \text{ m}^2/\text{s}$ ,  $\text{Pr} = 0.7003$ ,  $\beta = 1/T_f$ .

**ANALYSIS:** (a) The heat rate for the pin fin with an adiabatic tip condition is, Eq. 3.81,

$$q_f = M \tanh(mL) \quad (1)$$

$$M = (\bar{h}_{\text{tot}} P k A_c)^{1/2} \theta_b \quad m = (hP/kA_c)^{1/2} \quad (2,3)$$

$$P = \pi D \quad A_c = \pi D^2/4 \quad \theta_b = T_b - T_\infty \quad (4-6)$$

and the average coefficient is the sum of the convection and linearized radiation processes, respectively,

$$\bar{h}_{\text{tot}} = \bar{h}_{\text{fc}} + \bar{h}_{\text{rad}} \quad (7)$$

evaluated at  $\bar{T}_s = 125^\circ\text{C}$  with  $\bar{T}_f = (\bar{T}_s + T_\infty)/2 = 75^\circ\text{C} = 348 \text{ K}$ .

*Estimating  $\bar{h}_{\text{fc}}$ :* For the horizontal cylinder, Eq. 9.34, with

$$\text{Ra}_D = \frac{g\beta\Delta T D^3}{\nu\alpha}$$

Continued ...

**PROBLEM 9.63 (Cont.)**

$$Ra_D = \frac{9.8 \text{ m/s}^2 (1/348\text{K})(125 - 25)(0.006\text{m})^3}{20.72 \times 10^{-6} \text{ m}^2/\text{s} \times 29.60 \times 10^{-6} \text{ m}^2/\text{s}} = 991.79$$

$$\overline{Nu}_D = \left\{ 0.60 + \frac{0.387 Ra_D^{1/6}}{\left[ 1 + (0.559/Pr)^{9/16} \right]^{8/27}} \right\}^2$$

$$\overline{Nu}_D = \left\{ 0.60 + \frac{0.387 (991.79)^{1/6}}{\left[ 1 + (0.559/0.7003)^{9/16} \right]^{8/27}} \right\}^2 = 2.603$$

$$\overline{h}_{fc} = \overline{Nu}_D k/D = 2.603 \times 0.02985 \text{ W/m} \cdot \text{K} / 0.006\text{m} = 12.95 \text{ W/m}^2 \cdot \text{K}$$

Calculating  $\overline{h}_{rad}$ : The linearized radiation coefficient is

$$\overline{h}_{rad} = \varepsilon \sigma (\overline{T}_s + T_{sur}) (\overline{T}_s^2 + T_{sur}^2) \quad (8)$$

$$\overline{h}_{rad} = 0.5 \times 5.67 \times 10^{-8} \text{ W/m}^2 \cdot \text{K}^4 (398 + 298) (398^2 + 298^2) \text{ K}^3 = 4.88 \text{ W/m}^2 \cdot \text{K}$$

Substituting numerical values into Eqs. (1-7), find

$$q_{fin} = 2.04 \text{ W} \quad <$$

with  $\theta_b = 125 \text{ K}$ ,  $A_c = 2.827 \times 10^{-5} \text{ m}^2$ ,  $P = 0.01885 \text{ m}$ ,  $m = 14.44 \text{ m}^{-1}$ ,  $M = 2.909 \text{ W}$ , and  $\overline{h}_{tot} = 17.83 \text{ W/m}^2 \cdot \text{K}$ .

Using the *IHT Model, Extended Surfaces, Rectangular Pin Fin*, with the *Correlations Tool for Free Convection* and the *Properties Tool for Air*, the above analysis was repeated to obtain the following results.

$\overline{T}_s$ ( $^{\circ}\text{C}$ )	115	120	125	130	135
$q_f$ (W)	1.989	2.012	2.035	2.057	2.079
$(q_f - q_{f,o})/q_{f,o}$ (%)	-2.3	-1.1	0	+1.1	+2.2

The fin heat rate is not very sensitive to the choice of  $\overline{T}_s$  for the range  $T_s = 125 \pm 10 \text{ }^{\circ}\text{C}$ . For the base case condition, the fin tip temperature is  $T(L) = 114 \text{ }^{\circ}\text{C}$  so that  $\overline{T}_s \approx (T(L) + T_b)/2 = 132 \text{ }^{\circ}\text{C}$  would be consistent assumed value.

Continued ...



### PROBLEM 9.63 (Cont.)

(b) Using the *IHT Tool, Finite-Difference Equation, Steady-State, Extended Surfaces*, the temperature distribution was determined for a 15-node system from which the fin heat rate was determined. The local free convection and linearized radiation coefficients  $h_{\text{tot}} = h_{\text{fc}} + h_{\text{rad}}$ , were evaluated at local temperatures,  $T_m$ , using *IHT with the Correlations Tool, Free Convection, Horizontal Cylinder*, and the *Properties Tool for Air*, and Eq. (8). The local coefficient  $h_{\text{tot}}$  vs.  $T_s$  is nearly a linear function for the range  $114 \leq T_s \leq 150^\circ\text{C}$  so that it was reasonable to represent  $h_{\text{tot}}(T_s)$  as a *Lookup Table Function*. The fin heat rate follows from an energy balance on the base node, (see schematic next page)

$$q_f = q_a + q_b = (0.08949 + 1.879) \text{ W} = 1.97 \text{ W} \quad \leftarrow$$

$$q_a = h_b (P\Delta x/2)(T_b - T_\infty)$$

$$q_b = kA_c (T_b - T_1)/\Delta x$$

where  $T_b = 150^\circ\text{C}$ ,  $T_1 = 418.3 \text{ K} = 145.3^\circ\text{C}$ , and  $h_b = h_{\text{tot}}(T_b) = 18.99 \text{ W/m}^2 \cdot \text{K}$ .

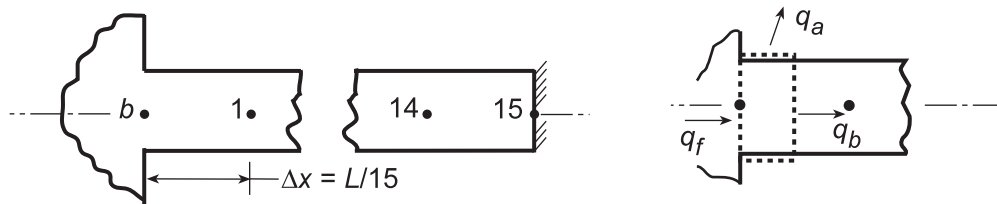

Considering variable coefficients, the fin heat rate is -3.3% lower than for the analytical solution with the assumed  $\bar{T}_s = 125^\circ\text{C}$ .

**COMMENTS:** (1) To validate the FDE model for part (b), we compared the temperature distribution and fin heat rate using a constant  $h_{\text{tot}}$  with the analytical solution ( $\bar{T}_s = 125^\circ\text{C}$ ). The results were identical indicating that the 15-node mesh is sufficiently fine.

(2) The fin temperature distribution (K) for the IHT finite-difference model of part (b) is

$T_b$	T01	T02	T03	T04	T05	T06	T07
423	418.3	414.1	410.3	406.8	403.7	401	398.6
T08	T09	T10	T11	T12	T13	T14	T15
396.6	394.9	393.5	392.4	391.7	391.2	391	390.9

## PROBLEM 9.64

**KNOWN:** Diameter, thickness, emissivity and thermal conductivity of steel pipe. Temperature of water flow in pipe. Cost of producing hot water.

**FIND:** Cost of daily heat loss from an uninsulated pipe.

**SCHEMATIC:**

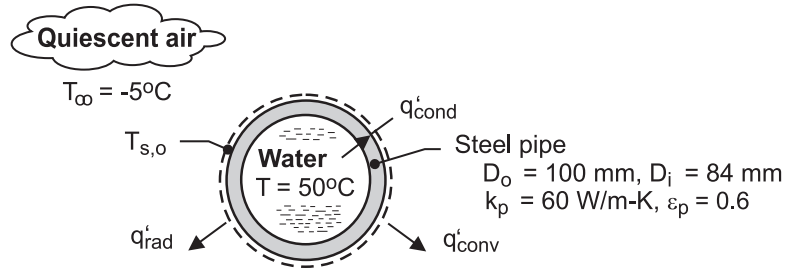

**ASSUMPTIONS:** (1) Steady-state, (2) Negligible convection resistance for water flow, (3) Negligible radiation from pipe surroundings, (4) Quiescent air, (5) Constant properties.

**PROPERTIES:** Table A-4, air ( $p = 1 \text{ atm}$ ,  $T_f \approx 295 \text{ K}$ ):  $k_a = 0.0259 \text{ W/m}\cdot\text{K}$ .  $\nu = 15.45 \times 10^{-6} \text{ m}^2/\text{s}$ ,  $\alpha = 21.8 \times 10^{-6} \text{ m}^2/\text{s}$ ,  $\text{Pr} = 0.708$ ,  $\beta = 3.39 \times 10^{-3} \text{ K}^{-1}$ .

**ANALYSIS:** Performing an energy balance for a control surface about the outer surface,  $q'_{\text{cond}} = q'_{\text{conv}} + q'_{\text{rad}}$ , it follows that

$$\frac{T - T_{s,o}}{R'_{\text{cond}}} = \bar{h} \pi D_o (T_{s,o} - T_{\infty}) + \varepsilon_p \pi D_o \sigma T_{s,o}^4 \quad (1)$$

where  $R'_{\text{cond}} = \ln(D_o/D_i)/2\pi k_p = \ln(100/84)/2\pi(60 \text{ W/m}\cdot\text{K}) = 4.62 \times 10^{-4} \text{ m}\cdot\text{K/W}$ . The convection coefficient may be obtained from the Churchill and Chu correlation. Hence, with  $\text{Ra}_D = g\beta(T_{s,o} - T_{\infty}) D_o^3 / \alpha\nu = 9.8 \text{ m/s}^2 \times 3.39 \times 10^{-3} \text{ K}^{-1} (0.1 \text{ m})^3 (T_{s,o} - 268 \text{ K}) / (21.8 \times 15.45 \times 10^{-12} \text{ m}^4/\text{s}^2) = 98,637 (T_{s,o} - 268)$ ,

$$\bar{\text{Nu}}_D = \left\{ 0.60 + \frac{0.387 \text{ Ra}_D^{1/6}}{\left[ 1 + (0.559/\text{Pr})^{9/16} \right]^{8/27}} \right\}^2 = \left\{ 0.60 + 2.182 (T_{s,o} - 268)^{1/6} \right\}^2$$

$$\bar{h} = \frac{k_a}{D_o} \bar{\text{Nu}}_D = 0.259 \text{ W/m}^2 \cdot \text{K} \left\{ 0.60 + 2.182 (T_{s,o} - 268)^{1/6} \right\}^2$$

Substituting the foregoing expression for  $\bar{h}$ , as well as values of  $R'_{\text{cond}}$ ,  $D_o$ ,  $\varepsilon_p$  and  $\sigma$  into Eq. (1), an iterative solution yields  $T_{s,o} = 322.9 \text{ K} = 49.9^\circ\text{C}$

It follows that  $\bar{h} = 6.10 \text{ W/m}^2 \cdot \text{K}$ , and the heat loss per unit length of pipe is

$$q' = q'_{\text{conv}} + q'_{\text{rad}} = 6.10 \text{ W/m}^2 \cdot \text{K} (\pi \times 0.1 \text{ m}) 54.9 \text{ K} + 0.6 (\pi \times 0.1 \text{ m}) 5.67 \times 10^{-8} \text{ W/m}^2 \cdot \text{K}^4 (322.9 \text{ K})^4 = (105.2 + 116.2) \text{ W/m} = 221.4 \text{ W/m}$$

The corresponding daily energy loss is  $Q' = 0.221 \text{ kW/m} \times 24 \text{ h/d} = 5.3 \text{ kW}\cdot\text{h/m}\cdot\text{d}$

and the associated cost is  $C' = (5.3 \text{ kW}\cdot\text{h/m}\cdot\text{d})(\$0.10/\text{kW}\cdot\text{h}) = \$0.53/\text{m}\cdot\text{d} <$

**COMMENTS:** (1) The heat loss is significant, and the pipe should be insulated. (2) The conduction resistance of the pipe wall is negligible relative to the combined convection and radiation resistance at the outer surface. Hence, the temperature of the outer surface is only slightly less than that of the water.

### PROBLEM 9.65

**KNOWN:** Insulated, horizontal pipe with aluminum foil having emissivity which varies from 0.12 to 0.36 during service. Pipe diameter is 300 mm and its surface temperature is 90°C.

**FIND:** Effect of emissivity degradation on heat loss with ambient air at 25°C and (a) quiescent conditions and (b) cross-wind velocity of 10 m/s.

**SCHEMATIC:**

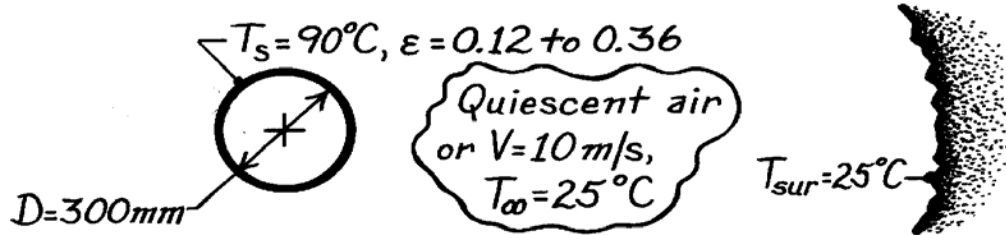

**ASSUMPTIONS:** (1) Steady-state conditions, (2) Surroundings are large compared to pipe, (3) Pipe has uniform temperature.

**PROPERTIES:** Table A-4, Air ( $T_f = (90 + 25)^\circ\text{C}/2 = 330\text{K}$ , 1 atm):  $\nu = 18.9 \times 10^{-6} \text{ m}^2/\text{s}$ ,  $k = 28.5 \times 10^{-3} \text{ W/m}\cdot\text{K}$ ,  $\alpha = 26.9 \times 10^{-6} \text{ m}^2/\text{s}$ ,  $\text{Pr} = 0.703$ .

**ANALYSIS:** The heat loss per unit length from the pipe is

$$q' = \bar{h}P(T_s - T_\infty) + \epsilon\sigma P(T_s^4 - T_{sur}^4)$$

where  $P = \pi D$  and  $\bar{h}$  needs to be evaluated for the two ambient air conditions.

(a) *Quiescent air.* Treating the pipe as a horizontal cylinder, find

$$\text{Ra}_D = \frac{g\beta(T_s - T_\infty)D^3}{\nu\alpha} = \frac{9.8 \text{ m/s}^2 (1/330\text{K})(90 - 25)\text{K}(0.30 \text{ m})^3}{18.9 \times 10^{-6} \text{ m}^2/\text{s} \times 26.9 \times 10^{-6} \text{ m}^2/\text{s}} = 1.025 \times 10^8$$

and using the Churchill-Chu correlation for  $10^{-5} < \text{Ra}_D < 10^{12}$ .

$$\bar{\text{Nu}}_D = \left\{ 0.60 + \frac{0.387 \text{Ra}_D^{1/6}}{\left[ 1 + (0.559/\text{Pr})^{9/16} \right]^{8/27}} \right\}^2$$

$$\bar{\text{Nu}}_D = \left\{ 0.60 + \frac{0.387 (1.025 \times 10^8)^{1/6}}{\left[ 1 + (0.559/0.703)^{9/16} \right]^{8/27}} \right\}^2 = 56.93$$

$$\bar{h}_D = \bar{\text{Nu}}_D k / D = 56.93 \times 0.0285 \text{ W/m}\cdot\text{K} / 0.300 \text{ m} = 5.4 \text{ W/m}^2 \cdot \text{K}$$

Continued ...

**PROBLEM 9.65 (Cont.)**

Hence, the heat loss is

$$q' = 5.4 \text{ W/m}^2 \cdot \text{K} (\pi 0.30 \text{ m}) (90 - 25) \text{ K} + \varepsilon \times 5.67 \times 10^{-8} \text{ W/m}^2 \cdot \text{K} (\pi 0.30 \text{ m}) (363^4 - 298^4) \text{ K}^4$$

$$q' = 331 + 506\varepsilon \begin{cases} \varepsilon = 0.12 \rightarrow q' = (331 + 61) = 392 \text{ W/m} & < \\ \varepsilon = 0.36 \rightarrow q' = (331 + 182) = 513 \text{ W/m} & < \end{cases}$$

The radiation effect accounts for 16 and 35%, respectively, of the heat rate.

(b) *Cross-wind condition.* With a cross-wind, find

$$\text{Re}_D = \frac{VD}{\nu} = \frac{10 \text{ m/s} \times 0.30 \text{ m}}{18.9 \times 10^{-6} \text{ m}^2/\text{s}} = 1.587 \times 10^5$$

and using the Hilpert correlation where  $C = 0.027$  and  $m = 0.805$  from Table 7.2,

$$\overline{\text{Nu}}_D = C \text{Re}_D^m \text{Pr}^{1/3} = 0.027 (1.587 \times 10^5)^{0.805} (0.703)^{1/3} = 368.9$$

$$\overline{h}_D = \text{Nu}_D \cdot k / D = 368.9 \times 0.0285 \text{ W/m} \cdot \text{K} / 0.30 \text{ m} = 35 \text{ W/m}^2 \cdot \text{K}.$$

Recognizing that *combined* free and forced convection conditions may exist, from Eq. 9.64 with  $n = 4$ ,

$$\text{Nu}_m^4 = \text{Nu}_F^4 + \text{Nu}_N^4 \quad \overline{h}_m = (5.4^4 + 35^4)^{1/4} = 35 \text{ W/m}^2 \cdot \text{K}$$

we find forced convection dominates. Hence, the heat loss is

$$q' = 35 \text{ W/m}^2 \cdot \text{K} (\pi 0.30 \text{ m}) (90 - 25) \text{ K} + \varepsilon \times 5.67 \times 10^{-8} \text{ W/m}^2 \cdot \text{K} (\pi 0.30 \text{ m}) (393^4 - 298^4) \text{ K}^4$$

$$q' = 2144 + 853\varepsilon \begin{cases} \varepsilon = 0.12 \rightarrow q' = 2144 + 102 = 2246 \text{ W/m} & < \\ \varepsilon = 0.36 \rightarrow q' = 2144 + 307 = 2451 \text{ W/m} & < \end{cases}$$

The radiation effect accounts for 5 and 13%, respectively, of the heat rate.

**COMMENTS:** (1) For high velocity wind conditions, radiation losses are quite low and the degradation of the foil is not important. However, for low velocity and quiescent air conditions, radiation effects are significant and the degradation of the foil can account for a nearly 25% change in heat loss.

(2) The radiation coefficient is in the range  $0.83$  to  $2.48 \text{ W/m}^2 \cdot \text{K}$  for  $\varepsilon = 0.12$  and  $0.36$ , respectively. Compare these values with those for convection.

## PROBLEM 9.66

**KNOWN:** Diameter, emissivity, and power dissipation of cylindrical heater. Temperature of ambient air and surroundings.

**FIND:** Steady-state temperature of heater and time required to come within 10°C of this temperature.

**SCHEMATIC:**

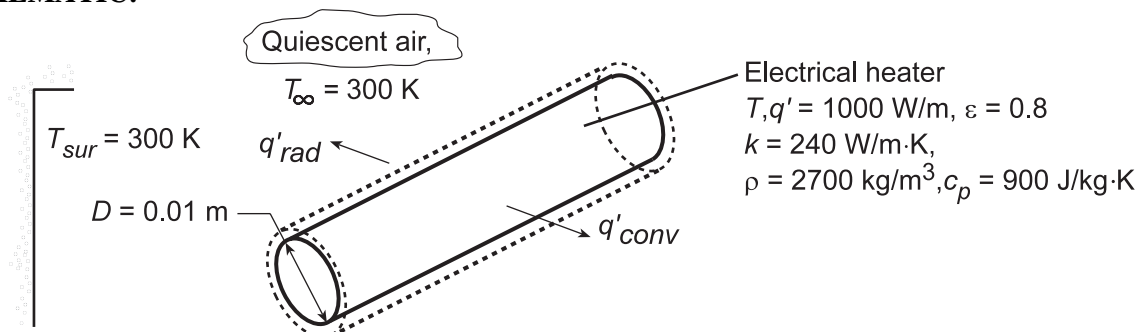

**ASSUMPTIONS:** (1) Air is quiescent, (2) Duct wall forms large surroundings about heater, (3) Heater may be approximated as a lumped capacitance.

**PROPERTIES:** Table A.4, air (Obtained from *Properties* Tool Pad of IHT).

**ANALYSIS:** Performing an energy balance on the heater, the final (steady-state) temperature may be obtained from the requirement that  $q' = q'_{conv} + q'_{rad}$ , or

$$q' = \bar{h}(\pi D)(T - T_{\infty}) + h_r(\pi D)(T - T_{sur})$$

where  $\bar{h}$  is obtained from Eq. 9.34 and  $h_r = \varepsilon\sigma(T + T_{sur})(T^2 + T_{sur}^2)$ . Using the *Correlations* Tool Pad of IHT to evaluate  $\bar{h}$ , this expression may be solved to obtain

$$T = 854 \text{ K} = 581^{\circ}\text{C} \quad \leftarrow$$

Under transient conditions, the energy balance is of the form,  $\dot{E}'_{st} = q' - q'_{conv} - q'_{rad}$ , or

$$\rho c_p \left( \frac{\pi D^2}{4} \right) dT/dt = q' - \bar{h}(\pi D)(T - T_{\infty}) - h_r(\pi D)(T - T_{sur})$$

Using the IHT *Lumped Capacitance* model with the *Correlations* Tool Pad, the above expression is integrated from  $t = 0$ , for which  $T_1 = 562.4 \text{ K}$ , to the time for which  $T = 844 \text{ K}$ . The integration yields

$$t = 183 \text{ s} \quad \leftarrow$$

The value of  $T_1 = 562.4 \text{ K}$  corresponds to the steady-state temperature for which the power dissipation is balanced by forced convection and radiation (see solution to Problem 7.50).

**COMMENTS:** The forced convection coefficient (Problems 7.49 and 7.50) of  $105 \text{ W/m}^2\cdot\text{K}$  is much larger than that associated with free convection for the steady-state conditions of this problem ( $14.6 \text{ W/m}^2\cdot\text{K}$ ). However, because of the correspondingly larger heater temperature, the radiation coefficient with free convection ( $42.9 \text{ W/m}^2\cdot\text{K}$ ) is much larger than that associated with forced convection ( $15.9 \text{ W/m}^2\cdot\text{K}$ ).

### PROBLEM 9.67

**KNOWN:** Cylindrical sensor of 12.5 mm diameter positioned horizontally in quiescent air at 27°C.

**FIND:** An expression for the free convection coefficient as a function of only  $\Delta T = T_s - T_\infty$  where  $T_s$  is the sensor temperature.

**ASSUMPTIONS:** (1) Steady-state conditions, (2) Uniform temperature over cylindrically shaped sensor, (3) Ambient air extensive and quiescent.

**PROPERTIES:** Table A-4, Air ( $T_f$ , 1 atm):  $\beta = 1/T_f$  and

$T_s$ (°C)	$T_f$ (K)	$\nu \times 10^6$ m <sup>2</sup> /s	$\alpha \times 10^6$ m <sup>2</sup> /s	$k \times 10^3$ W/m·K	Pr
30	302	16.09	22.8	26.5	0.707
55	314	17.30	24.6	27.3	0.705
80	327	18.61	26.5	28.3	0.703

**ANALYSIS:** For the cylindrical sensor, using Eqs. 9.25 and 9.34,

$$Ra_D = \frac{g\beta\Delta TD^3}{\nu\alpha} \quad \overline{Nu}_D = \frac{\overline{h}_D D}{k} = \left\{ 0.60 + \frac{0.387 Ra_D^{1/6}}{\left[1 + (0.559/Pr)^{9/16}\right]^{8/27}} \right\}^2 \quad (1.2)$$

where properties are evaluated at  $T_f = (T_s + T_\infty)/2$ . With  $30 \leq T_s \leq 80^\circ\text{C}$  and  $T_\infty = 27^\circ\text{C}$ ,  $302 \leq T_f \leq 326$  K. Using properties evaluated at the mid-range of  $T_f$ ,  $\overline{T}_f = 314$  K, find

$$Ra_D = \frac{9.8 \text{ m/s}^2 (1/314 \text{ K}) \Delta T (0.0125 \text{ m})^3}{17.30 \times 10^{-6} \text{ m}^2/\text{s} \times 24.6 \times 10^{-6} \text{ m}^2/\text{s}} = 143.2 \Delta T$$

$$\overline{h}_D = \frac{0.0273 \text{ W/m}\cdot\text{K}}{0.0125 \text{ m}} \left\{ 0.60 + \frac{0.387 (143.2 \Delta T)^{1/6}}{\left[1 + (0.559/0.705)^{9/16}\right]^{8/27}} \right\}^2$$

$$\overline{h}_D = 2.184 \left\{ 0.60 + 0.734 \Delta T^{1/6} \right\}^2. \quad (3) <$$

**COMMENTS:** (1) The effect of using a fixed film temperature,  $\overline{T}_f = 314 \text{ K} = 41^\circ\text{C}$ , for the full range  $30 \leq T_s \leq 80^\circ\text{C}$  can be seen by comparing results from the approximate Eq. (3) and the correlation, Eq. (2), with the proper film temperature. The results are summarized in the table.

$T_s$ (°C)	$\Delta T = T_s - T_\infty$ (°C)	Correlation			Eq. (3)
		$Ra_D$	$\overline{Nu}_D$	$\overline{h}_D$ (W/m <sup>2</sup> ·K)	$\overline{h}_D$ (W/m <sup>2</sup> ·K)
30	3	518	2.281	4.83	4.80
55	28	4011	3.534	7.72	7.71

The approximate expression for  $\overline{h}_D$  is in excellent agreement with the correlation.

(2) In calculating heat rates it may be important to consider radiation exchange with the surroundings.

## PROBLEM 9.68

**KNOWN:** Thin-walled tube mounted horizontally in quiescent air and wrapped with an electrical tape passing hot fluid in an experimental loop.

**FIND:** (a) Heat flux  $q_e''$  from the heating tape required to prevent heat loss from the hot fluid when (a) neglecting and (b) including radiation exchange with the surroundings, (c) Effect of insulation on  $q_e''$  and convection/radiation rates.

**SCHEMATIC:**

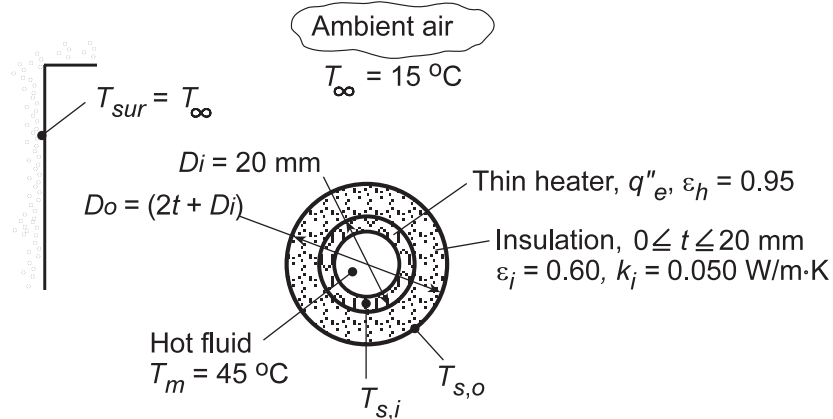

**ASSUMPTIONS:** (1) Steady-state conditions, (2) Ambient air is quiescent and extensive, (3) Surroundings are large compared to the tube.

**PROPERTIES:** Table A.4, Air ( $T_f = (T_s + T_\infty)/2 = (45 + 15)^\circ\text{C}/2 = 303\text{ K}$ , 1 atm):  $\nu = 16.19 \times 10^{-6}\text{ m}^2/\text{s}$ ,  $\alpha = 22.9 \times 10^{-6}\text{ m}^2/\text{s}$ ,  $k = 26.5 \times 10^{-3}\text{ W/m}\cdot\text{K}$ ,  $\text{Pr} = 0.707$ ,  $\beta = 1/T_f$ .

**ANALYSIS:** (a,b) To prevent heat losses from the hot fluid, the heating tape temperature must be maintained at  $T_m$ ; hence  $T_{s,i} = T_m$ . From a surface energy balance,

$$q_e'' = q_{\text{conv}}'' + q_{\text{rad}}'' = (\bar{h}_{D_i} + h_r)(T_{s,i} - T_\infty)$$

where the linearized radiation coefficient, Eq. 1.9, is  $h_r = \epsilon\sigma(T_{s,i} + T_\infty)(T_{s,i}^2 + T_\infty^2)$ , or

$$h_r = 0.95 \times 5.67 \times 10^{-8}\text{ W/m}^2 \cdot \text{K}^4 (318 + 288)(318^2 + 288^2)\text{ K}^3 = 6.01\text{ W/m}^2 \cdot \text{K}.$$

*Neglecting radiation:* For the horizontal cylinder, Eq. 9.34 yields

$$\text{Ra}_D = \frac{g\beta(T_{s,i} - T_\infty)D_i^3}{\nu\alpha} = \frac{9.8\text{ m/s}^2 (1/303\text{ K})(45 - 15)\text{ K}(0.020\text{ m})^3}{16.19 \times 10^{-6}\text{ m}^2/\text{s} \times 22.9 \times 10^{-6}\text{ m}^2/\text{s}} = 20,900$$

$$\overline{\text{Nu}}_D = \frac{\bar{h}_{D_i} D_i}{k} = \left\{ 0.60 + \frac{0.387\text{Ra}_D^{1/6}}{\left[1 + (0.559/\text{Pr})^{9/16}\right]^{8/27}} \right\}^2$$

Continued ...

**PROBLEM 9.68 (Cont.)**

$$\bar{h}_{D_i} = \frac{0.0265 \text{ W/m} \cdot \text{K}}{0.020 \text{ m}} \left\{ 0.60 + \frac{0.386(20,900)^{1/6}}{\left[ 1 + (0.559/0.707)^{9/16} \right]^{8/27}} \right\}^2 = 6.90 \text{ W/m}^2 \cdot \text{K}$$

Hence, neglecting radiation, the required heat flux is

$$q_e'' = 6.90 \text{ W/m}^2 \cdot \text{K} (45 - 15) \text{ K} = 207 \text{ W/m}^2 \cdot \text{K} \quad <$$

*Considering radiation:* The required heat flux considering radiation is

$$q_e'' = (6.90 + 6.01) \text{ W/m}^2 \cdot \text{K} (45 - 15) \text{ K} = 387 \text{ W/m}^2 \cdot \text{K} \quad <$$

(c) With insulation, the surface energy balance must be modified to account for an increase in the outer diameter from  $D_i$  to  $D_o = D_i + 2t$  and for the attendant thermal resistance associated with conduction across the insulation. From an energy balance at the inner surface of the insulation,

$$q_e'' (\pi D_i) = q'_{\text{cond}} = \frac{2\pi k_i (T_m - T_{s,o})}{\ln(D_o/D_i)}$$

and from an energy balance at the outer surface,

$$q'_{\text{cond}} = q'_{\text{conv}} + q'_{\text{rad}} = \pi D_o (\bar{h}_{D_o} + h_r) (T_{s,o} - T_\infty)$$

The foregoing expressions may be used to determine  $T_{s,o}$  and  $q_e''$  as a function of  $t$ , with the IHT

*Correlations and Properties* Tool Pads used to evaluate  $\bar{h}_{D_o}$ . The desired results are plotted as follows.

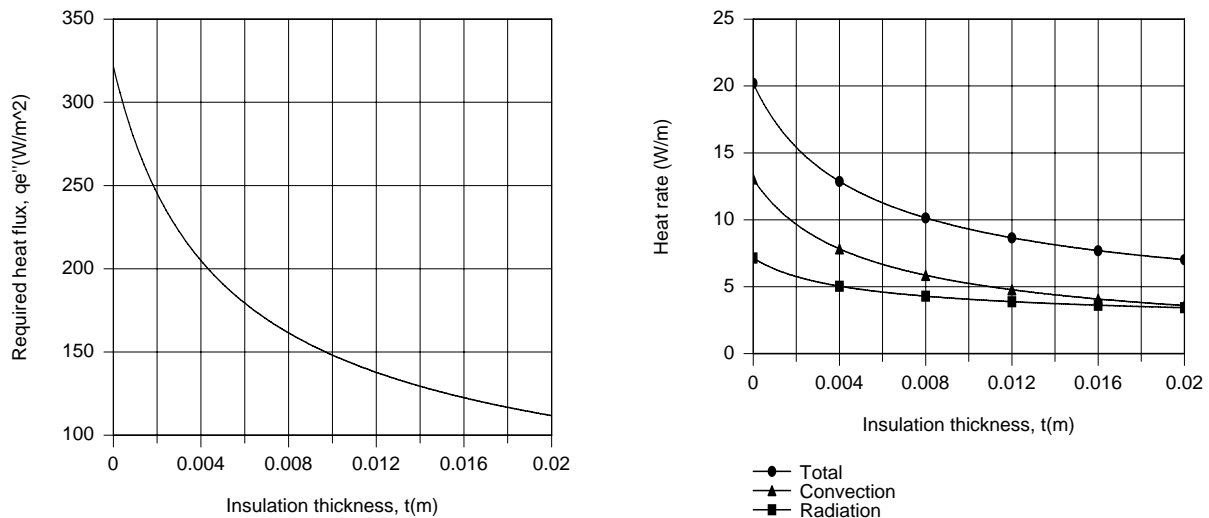

By adding 20 mm of insulation, the required power dissipation is reduced by a factor of approximately 3. Convection and radiation heat rates at the outer surface are comparable.

**COMMENTS:** Over the range of insulation thickness,  $T_{s,o}$  decreases from 45°C to 20°C, while  $\bar{h}_{D_o}$  and  $h_r$  decrease from 6.9 to 3.5 W/m<sup>2</sup>·K and from 3.8 to 3.3 W/m<sup>2</sup>·K, respectively.



## PROBLEM 9.69

**KNOWN:** A billet of stainless steel AISI 316 with a diameter of 150 mm and length 500 mm emerges from a heat treatment process at 200°C and is placed into an unstirred oil bath maintained at 20°C.

**FIND:** (a) Determine whether it is advisable to position the billet in the bath with its centerline horizontal or vertical in order to decrease to the cooling time, and (b) Estimate the time for the billet to cool to 30°C for the better positioning arrangement.

**SCHEMATIC:**

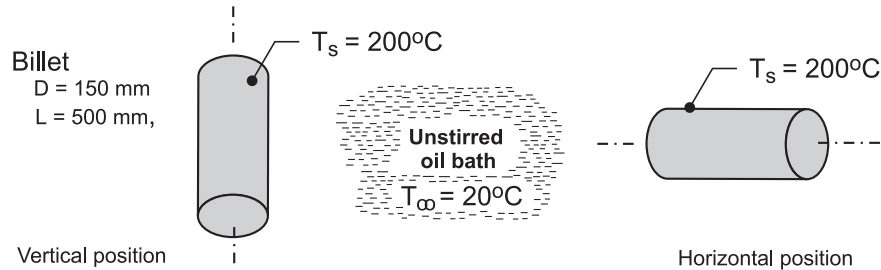

**ASSUMPTIONS:** (1) Steady-state conditions for part (a), (2) Oil bath approximates a quiescent fluid, (3) Consider only convection from the lateral surface of the cylindrical billet; and (4) For part (b), the billet has a uniform initial temperature.

**PROPERTIES:** Table A-5, Engine oil ( $T_f = (T_s + T_\infty)/2$ ): see Comment 1. Table A-1, AISI 316 (400 K):  $\rho = 8238 \text{ kg/m}^3$ ,  $c_p = 468 \text{ J/kg}\cdot\text{K}$ ,  $k = 15 \text{ W/m}\cdot\text{K}$ .

**ANALYSIS:** (a) For the purpose of determining whether the horizontal or vertical position is preferred for faster cooling, consider only free convection from the lateral surface. The heat loss from the lateral surface follows from the rate equation

$$q = \bar{h} A_s (T_s - T_\infty)$$

*Vertical position.* The lateral surface of the cylindrical billet can be considered as a vertical surface of height  $L$ , width  $P = \pi D$ , and area  $A_s = PL$ . The Churchill-Chu correlation, Eq. 9.26, is appropriate to estimate  $\bar{h}_L$ ,

$$\overline{\text{Nu}}_L = \frac{\bar{h}_L L}{k} = \left\{ 0.825 + \frac{0.387 \text{Ra}_L^{1/6}}{\left[ 1 + (0.492/\text{Pr})^{9/16} \right]^{8/27}} \right\}^2$$

$$\text{Ra}_L = \frac{g\beta(T_s - T_\infty)L^3}{\nu\alpha}$$

with properties evaluated at  $T_f = (T_s + T_\infty)/2$ .

*Horizontal position.* In this position, the billet is considered as a long horizontal cylinder of diameter  $D$  for which the Churchill-Chu correlation of Eq. 9.34 is appropriate to estimate  $\bar{h}_D$ ,

$$\overline{\text{Nu}}_L = \frac{\bar{h}_D D}{k} = \left\{ 0.60 + \frac{0.387 \text{Ra}_D^{1/6}}{\left[ 1 + (0.559/\text{Pr})^{9/16} \right]^{8/27}} \right\}^2$$

Continued ...

**PROBLEM 9.69 (Cont.)**

$$Ra_D = \frac{g\beta(T_s - T_\infty)D^3}{\nu\alpha}$$

with properties evaluated at  $T_f$ . The heat transfer area is also  $A_s = PL$ .

Using the foregoing relations in *IHT* with the thermophysical properties library as shown in Comment 1, the analysis results are tabulated below.

$Ra_L = 1.36 \times 10^{11}$	$\overline{Nu}_L = 801$	$\overline{h}_L = 218 \text{ W/m}^2 \cdot \text{K}$	(vertical)
$Ra_D = 3.67 \times 10^9$	$\overline{Nu}_D = 245$	$\overline{h}_D = 221 \text{ W/m}^2 \cdot \text{K}$	(horizontal)

Recognize that the orientation has a small effect on the convection coefficient for these conditions, but we'll select the horizontal orientation as the preferred one.

(b) Evaluate first the Biot number to determine if the lumped capacitance method is valid.

$$Bi = \frac{\overline{h}_D (D_o/2)}{k} = \frac{221 \text{ W/m}^2 \cdot \text{K} (0.150 \text{ m}/2)}{15 \text{ W/m} \cdot \text{K}} = 1.1$$

Since  $Bi \gg 0.1$ , the spatial effects are important and we should use the one-term series approximation for the infinite cylinder, Eq. 5.52. Since  $\overline{h}_D$  will decrease as the billet cools, we need to estimate an average value for the cooling process from 200°C to 30°C. Based upon the analysis summarized in Comment 1, use  $\overline{h}_D = 119 \text{ W/m}^2 \cdot \text{K}$ . Using the transient model for the infinite cylinder in *IHT*, (see Comment 2) find for  $T(r_o, t_o) = 30^\circ\text{C}$ ,

$$t_o = 3845 \text{ s} = 1.1 \text{ h}$$

<

**COMMENTS:** (1) The *IHT* code using the convection correlation functions to estimate the coefficients is shown below. This same code was used to calculate  $\overline{h}_D$  for the range  $30 \leq T_s \leq 200^\circ\text{C}$  and determine that an average value for the cooling period of part (b) is  $119 \text{ W/m}^2 \cdot \text{K}$ .

```

/* Results - convection coefficients, Ts = 200 C
hDbar hLbar D L Tinf_C Ts_C
221.4 217.5 0.15 0.5 20 200 */

/* Results - correlation parameters, Ts = 200 C
NuDbar NuLbar Pr RaD RaL
244.7 801.3 219.2 3.665E9 1.357E11 */

/* Results - properties, Ts = 200 C; Tf = 383 K
Pr alpha beta deltaT k nu Tf
219.2 7.188E-8 0.0007 180 0.1357 1.582E-5 383

/* Correlation description: Free convection (FC), long horizontal cylinder (HC),
10^-5 <= RaD <= 10^12, Churchill-Chu correlation, Eqs 9.25 and 9.34 . See Table 9.2 . */
NuDbar = NuD_bar_FC_HC(RaD,Pr) // Eq 9.34
NuDbar = hDbar * D / k
RaD = g * beta * deltaT * D^3 / (nu * alpha) //Eq 9.25
deltaT = abs(Ts - Tinf)
g = 9.8 // gravitational constant, m/s^2
// Evaluate properties at the film temperature, Tf.
Tf = Tfluid_avg(Tinf,Ts)

```

Continued .....

## PROBLEM 9.69 (Cont.)

**/\* Correlation description: Free convection (FC) for a vertical plate (VP),** Eqs 9.25 and 9.26 . See Table 9.2 . \*/

$NuL_{bar} = NuL_{bar\_FC\_VP}(RaL, Pr)$  // Eq 9.26

$NuL_{bar} = hL_{bar} * L / k$

$RaL = g * \beta * \Delta T * L^3 / (\nu * \alpha)$  //Eq 9.25

**// Input variables**

D = 0.15

L = 0.5

Tinf\_C = 20

Ts\_C = 200

**// Engine Oil property functions : From Table A.5**

// Units: T(K)

$\nu = \nu\_T(\text{"Engine Oil"}, Tf)$  // Kinematic viscosity, m<sup>2</sup>/s

$k = k\_T(\text{"Engine Oil"}, Tf)$  // Thermal conductivity, W/m·K

$\alpha = \alpha\_T(\text{"Engine Oil"}, Tf)$  // Thermal diffusivity, m<sup>2</sup>/s

$Pr = Pr\_T(\text{"Engine Oil"}, Tf)$  // Prandtl number

$\beta = \beta\_T(\text{"Engine Oil"}, Tf)$  // Volumetric coefficient of expansion, K<sup>-1</sup>

**// Conversions**

Tinf\_C = Tinf - 273

Ts\_C = Ts - 273

(2) The portion of the *IHT* code used for the transient analysis is shown below. Recognize that we have not considered heat losses from the billet end surfaces, also, we should consider the billet as a three-dimensional object rather than as a long cylinder.

**/\* Results - time to cool to 30 C, center and surface temperatures**

D	T_xt_C	Ti_C	Tinf_C	r	h	t	
0.15	30.01	200	20	0.075	119	3845	*/
0.15	33.19	200	20	0	119	3845	

**// Transient conduction model, cylinder (series solution)**

// The temperature distribution T(r,t) is

$T_{xt} = T_{xt\_trans}(\text{"Cylinder"}, rstar, Fo, Bi, Ti, Tinf)$  // Eq 5.52

// The dimensionless parameters are

$rstar = r / ro$

$Bi = h * ro / k$

$Fo = \alpha * t / ro^2$

$\alpha = k / (\rho * cp)$

### PROBLEM 9.70

**KNOWN:** Diameter, initial temperature and emissivity of long steel rod. Temperature of air and surroundings.

**FIND:** (a) Average surface convection coefficient, (b) Effective radiation coefficient, (c,d) Maximum allowable conveyor time.

**SCHEMATIC:**

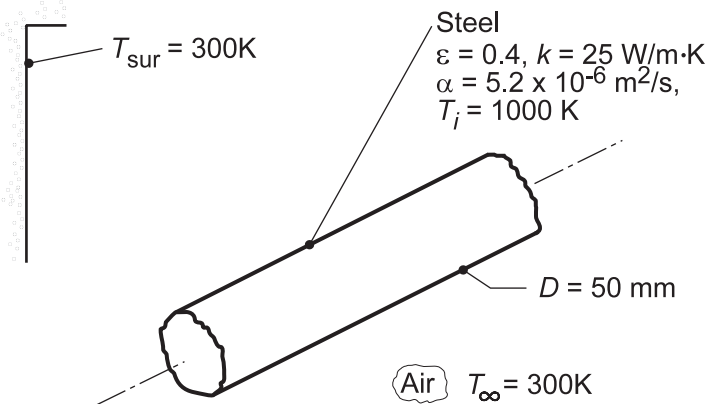

**ASSUMPTIONS:** (1) Negligible effect of forced convection, (2) Constant properties, (3) Large surroundings, (4) Quiescent air.

**PROPERTIES:** Stainless steel (given):  $k = 25 \text{ W/m}\cdot\text{K}$ ,  $\alpha = 5.2 \times 10^{-6} \text{ m}^2/\text{s}$ ; Table A.4, Air ( $T_f = 650 \text{ K}$ , 1 atm):  $\nu = 6.02 \times 10^{-5} \text{ m}^2/\text{s}$ ,  $\alpha = 8.73 \times 10^{-5} \text{ m}^2/\text{s}$ ,  $k = 0.0497 \text{ W/m}\cdot\text{K}$ ,  $\text{Pr} = 0.69$ .

**ANALYSIS:** (a) For free convection from a horizontal cylinder,

$$\text{Ra}_D = \frac{g\beta(T_s - T_{\infty})D^3}{\alpha\nu} = \frac{9.8 \text{ m/s}^2 (1/650 \text{ K})(1000 - 300) \text{ K} (0.05 \text{ m})^3}{6.02 \times 8.73 \times 10^{-10} \text{ m}^4/\text{s}^2} = 2.51 \times 10^5$$

The Churchill and Chu correlation yields

$$\overline{\text{Nu}}_D = \left\{ 0.60 + \frac{0.387 \text{Ra}_D^{1/6}}{\left[ 1 + (0.559/\text{Pr})^{9/16} \right]^{8/27}} \right\}^2 = \left\{ 0.60 + \frac{0.387 (2.51 \times 10^5)^{1/6}}{\left[ 1 + (0.559/0.69)^{9/16} \right]^{8/27}} \right\}^2 = 9.9$$

$$\bar{h} = \overline{\text{Nu}}_D k/D = 9.9 (0.0497 \text{ W/m}\cdot\text{K}) / 0.05 \text{ m} = 9.84 \text{ W/m}^2 \cdot \text{K} \quad <$$

(b) The radiation heat transfer coefficient is

$$h_r = \epsilon\sigma(T_s + T_{\text{sur}})(T_s^2 + T_{\text{sur}}^2) = 0.4 \times 5.67 \times 10^{-8} \text{ W/m}^2 \cdot \text{K}^4 (1000 + 300) \text{ K} \left[ (1000)^2 + (300)^2 \right] \text{ K}^2 = 32.1 \text{ W/m}^2 \cdot \text{K} \quad <$$

(c) For the long stainless steel rod and the initial values of  $\bar{h}$  and  $h_r$ ,

$$\text{Bi} = (\bar{h} + h_r)(r_o/2)/k = 42.0 \text{ W/m}^2 \cdot \text{K} \times 0.0125 \text{ m} / 25 \text{ W/m}\cdot\text{K} = 0.021.$$

Hence, the lumped capacitance method can be used.

$$\frac{T - T_{\infty}}{T_i - T_{\infty}} = \frac{600 \text{ K}}{700 \text{ K}} = \exp(-\text{Bi} \cdot \text{Fo}) = \exp(-0.021\text{Fo})$$

Continued...

**PROBLEM 9.70 (Cont.)**

$$Fo = 7.34 = \alpha t / (r_o/2)^2 = 0.0333t$$

$$t = 221 \text{ s.}$$

<

(d) Using the IHT *Lumped Capacitance* Model with the *Correlations* and *Properties* Tool Pads, a more accurate estimate of the maximum allowable transit time may be obtained by evaluating the numerical integration,

$$\int_0^t dt = -\frac{\rho c_p D}{4} \int_{1000\text{K}}^{900\text{K}} \frac{dT}{(\bar{h} + h_r)(T - T_\infty)}$$

where  $\rho c_p = k/\alpha = 4.81 \times 10^6 \text{ J/K} \cdot \text{m}^3$ . The integration yields

$$t = 245 \text{ s}$$

<

At this time, the convection and radiation coefficients are  $\bar{h} = 9.75$  and  $h_r = 24.5 \text{ W/m}^2 \cdot \text{K}$ , respectively.

**COMMENTS:** Since  $\bar{h}$  and  $h_r$  decrease with increasing time, the maximum allowable conveyor time is underestimated by the result of part (c).

## PROBLEM 9.71

**KNOWN:** Velocity and temperature of air flowing through a duct of prescribed diameter. Temperature of duct surroundings. Thickness, thermal conductivity and emissivity of applied insulation.

**FIND:** (a) Duct surface temperature and heat loss per unit length with no insulation, (b) Surface temperatures and heat loss with insulation.

**SCHEMATIC:**

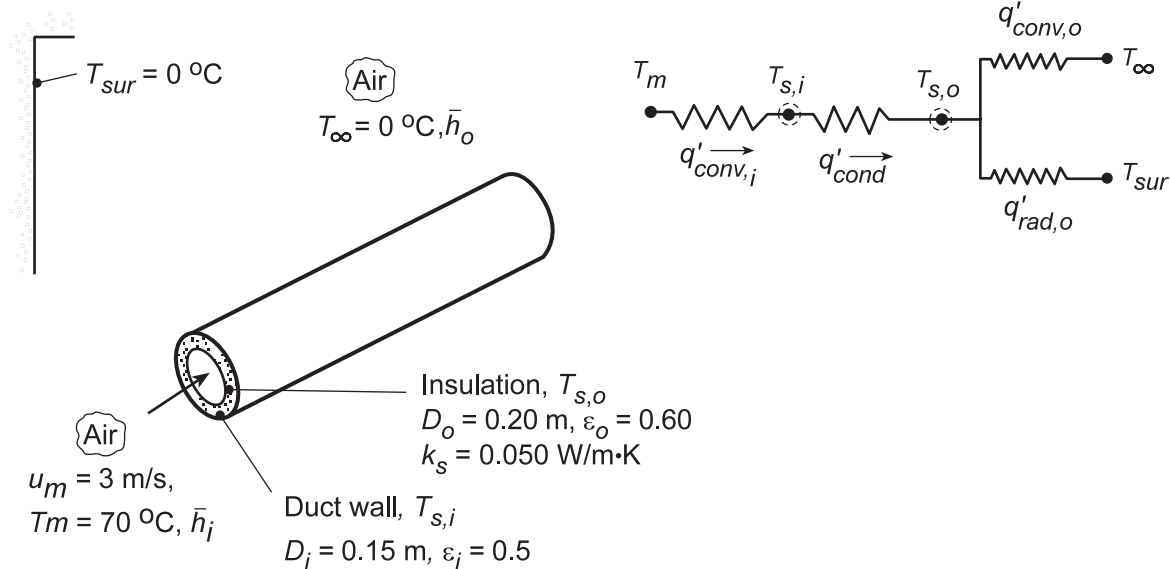

**ASSUMPTIONS:** (1) Steady-state conditions, (2) Fully-developed internal flow, (3) Negligible duct wall resistance, (4) Duct outer surface is diffuse-gray, (5) Outside air is quiescent, (6) Pressure of inside and outside air is atmospheric.

**PROPERTIES:** Table A.4, Air ( $T_m = 70^\circ\text{C}$ ):  $\nu = 20.22 \times 10^{-6} \text{ m}^2/\text{s}$ ,  $\text{Pr} = 0.70$ ,  $k = 0.0295 \text{ W/m}\cdot\text{K}$ ; Table A.4, Air ( $T_f \approx 27^\circ\text{C}$ ):  $\nu = 15.89 \times 10^{-6} \text{ m}^2/\text{s}$ ,  $\text{Pr} = 0.707$ ,  $k = 0.0263 \text{ W/m}\cdot\text{K}$ ,  $\alpha = 22.5 \times 10^{-6} \text{ m}^2/\text{s}$ ,  $\beta = 0.00333 \text{ K}^{-1}$ .

**ANALYSIS:** (a) Performing an energy balance on the duct wall with no insulation ( $T_{s,i} = T_{s,o}$ ),

$$q'_{\text{conv},i} = q'_{\text{conv},o} + q'_{\text{rad},o} \quad h_i (\pi D_i) (T_m - T_{s,i}) = h_o (\pi D_i) (T_{s,i} - T_\infty) + \epsilon_i \sigma (\pi D_i) (T_{s,i}^4 - T_{\text{sur}}^4)$$

with  $\text{Re}_{D,i} = u_m D_i / \nu = 3 \text{ m/s} \times 0.15 \text{ m} / (20.22 \times 10^{-6} \text{ m}^2/\text{s}) = 2.23 \times 10^4$ , the internal flow is turbulent, and from the Dittus-Boelter correlation,

$$h_i = \frac{k}{D_i} 0.023 \text{Re}_{D,i}^{4/5} \text{Pr}^{0.3} = \frac{0.0295 \text{ W/m}\cdot\text{K}}{0.15 \text{ m}} 0.023 (2.23 \times 10^4)^{4/5} (0.7)^{0.3} = 12.2 \text{ W/m}^2 \cdot \text{K}.$$

For free convection, the Rayleigh number is

$$\text{Ra}_{D,i} = \frac{g\beta(T_{s,i} - T_\infty)D_i^3}{\nu\alpha} = \frac{9.8 \text{ m/s}^2 (0.0033)(T_{s,i} - 273)(0.15)^3 \text{ m}^3}{15.89 \times 10^{-6} \text{ m}^2/\text{s} \times 22.5 \times 10^{-6} \text{ m}^2/\text{s}} = 3.08 \times 10^5 (T_{s,i} - T_\infty)$$

and from Eq. 9.34,

$$\bar{h}_o = \frac{k}{D_i} \left[ 0.60 + \frac{0.387 \text{Ra}_{D,i}^{1/6}}{\left[ 1 + (0.559/\text{Pr})^{9/16} \right]^{8/27}} \right]^2 = \frac{0.0263}{0.15} \left[ 0.60 + \frac{0.387 \left[ 3.08 \times 10^5 (T_{s,i} - T_\infty) \right]^{1/6}}{\left[ 1 + (0.559/0.707)^{9/16} \right]^{8/27}} \right]^2$$

Continued...

**PROBLEM 9.71 (Cont.)**

$$\bar{h}_o = 0.175 \left[ 0.60 + 2.64 (T_{s,i} - T_\infty)^{1/6} \right]^2$$

Hence

$$12.2(343 - T_{s,i}) = 0.175 \left\{ 0.60 + 2.64 (T_{s,i} - 273)^{1/6} \right\}^2 (T_{s,i} - 273) + 0.5 \times 5.67 \times 10^{-8} \left[ T_{s,i}^4 - (273)^4 \right]$$

A trial-and-error solution gives  $T_{s,i} \approx 314.7 \text{ K} \approx 41.7^\circ \text{C}$  <

The heat loss per unit length is then

$$q' = q'_{\text{conv},i} \approx 12.2(\pi \times 0.15)(70 - 42) \approx 163 \text{ W/m.}$$
 <

(b) Performing energy balances at the inner and outer surfaces, we obtain, respectively,

$$q'_{\text{conv},i} = q'_{\text{cond}}$$

or,

$$\bar{h}_i (\pi D_i) (T_m - T_{s,i}) = \frac{2\pi k_s (T_{s,i} - T_{s,o})}{\ln(D_o/D_i)}$$

and,

$$q'_{\text{cond}} = q'_{\text{conv},o} + q'_{\text{rad},o}$$

or,

$$\frac{2\pi k_s (T_{s,i} - T_{s,o})}{\ln(D_o/D_i)} = \bar{h}_o (\pi D_o) (T_s - T_\infty) + \varepsilon_o \sigma (\pi D_o) (T_{s,o}^4 - T_{\text{sur}}^4)$$

Using the IHT workspace with the *Correlations* and *Properties* Tool Pads to solve the energy balances for the unknown surface temperatures, we obtain

$$T_{s,i} = 60.8^\circ \text{C} \quad T_{s,o} = 12.5^\circ \text{C}$$
 <

With the heat loss per unit length again evaluated from the inside convection process, we obtain

$$q' = q'_{\text{conv},i} = 52.8 \text{ W/m}$$
 <

**COMMENTS:** For part (a), the outside convection coefficient is  $\bar{h}_o = 5.4 \text{ W/m}^2 \cdot \text{K} < h_i$ . The outside heat transfer rates are  $q'_{\text{conv},o} \approx 106 \text{ W/m}$  and  $q'_{\text{rad},o} \approx 57 \text{ W/m}$ . For part (b),  $\bar{h}_o = 3.74 \text{ W/m}^2 \cdot \text{K}$ ,  $q'_{\text{conv},o} = 29.4 \text{ W/m}$ , and  $q'_{\text{rad},o} = 23.3 \text{ W/m}$ . Although  $T_{s,i}$  increases with addition of the insulation, there is a substantial reduction in  $T_{s,o}$  and hence the heat loss.

## PROBLEM 9.72

**KNOWN:** Biological fluid with prescribed flow rate and inlet temperature flowing through a coiled, thin-walled, 5-mm diameter tube submerged in a large water bath maintained at 50°C.

**FIND:** (a) Length of tube and number of coils required to provide an exit temperature of  $T_{m,o} = 38^\circ\text{C}$ , and (b) Variations expected in  $T_{m,o}$  for a  $\pm 10\%$  change in the mass flow rate for the tube length determined in part (a).

**SCHEMATIC:**

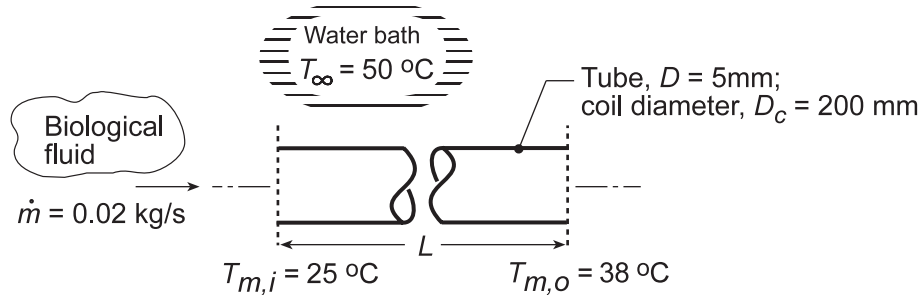

**ASSUMPTIONS:** (1) Steady-state conditions, (2) Coiled tube approximates a horizontal tube experiencing free convection in a quiescent, extensive medium (water bath), (3) Biological fluid has thermophysical properties of water, (4) Negligible tube wall thermal resistance, (5) Biological fluid flow is incompressible with negligible viscous dissipation, and (6) Flow in tube is fully developed.

**PROPERTIES:** *Table A.4* Water - cold side ( $T_{m,c} = (T_{m,i} + T_{m,o}) / 2 = 304.5 \text{ K}$ ):  $c_{p,c} = 4178 \text{ J/kg}\cdot\text{K}$ ,  $\mu_c = 7.776 \times 10^{-4} \text{ N}\cdot\text{s/m}^2$ ,  $k_c = 0.6193 \text{ W/m}\cdot\text{K}$ ,  $\text{Pr}_c = 5.263$ ; *Table A.4*, Water - hot side

( $\bar{T}_f = (T_s + T_\infty) / 2 = 315.7 \text{ K}$ , see comment 1):  $k_h = 0.635 \text{ W/m}\cdot\text{K}$ ,  $\text{Pr}_h = 4.11$ ,  $\nu_h = 6.294 \times 10^{-7} \text{ m}^2/\text{s}$ ,  $\alpha_h = 1.533 \times 10^{-7} \text{ m}^2/\text{s}$ ,  $\beta_h = 4.054 \times 10^{-4} \text{ K}^{-1}$ ; Water ( $T_s = 308.4 \text{ K}$ ):  $\mu_s = 7.28 \times 10^{-4} \text{ N}\cdot\text{s/m}^2$ .

**ANALYSIS:** (a) Following the treatment of Section 8.3.3, the coil experiences internal flow of the cold biological fluid (c) and free convection with the external hot fluid (h). From Eq. 8.45a, we can solve for  $\bar{U}A_s$ ,

$$\bar{U}A_s = -\dot{m}c_{p,c} \ln \left( \frac{T_\infty - T_{m,o}}{T_\infty - T_{m,i}} \right) = -0.02 \text{ kg/s} \times 4178 \text{ J/kg}\cdot\text{K} \times \ln \left( \frac{50 - 38}{50 - 25} \right) = 61.3 \text{ W/K}$$

with  $A_s = \pi DL$  and for the overall coefficient  $\bar{U} = (1/\bar{h}_c + 1/\bar{h}_h)^{-1}$ ,  $\bar{h}_c$  and  $\bar{h}_h$  are the average convection coefficients for internal flow and external free convection, respectively.

*Internal flow,  $\bar{h}_c$ :* To characterize the flow, calculate the Reynolds number,

$$\text{Re}_{D,c} = \frac{4\dot{m}}{\pi D \mu_c} = \frac{4 \times 0.02 \text{ kg/s}}{\pi \times 0.005 \text{ m} \times 777.6 \times 10^{-6} \text{ N}\cdot\text{s/m}^2} = 6550$$

evaluating properties at  $\bar{T}_m = (T_{m,i} + T_{m,o}) / 2 = (25 + 38)^\circ\text{C} / 2 = 31.5^\circ\text{C} = 304.5\text{K}$ . Note that transition to turbulence occurs at a higher Reynolds number in a coiled tube flow, as given by Eq. 8.74,

$$\text{Re}_{D,c,cr} = \text{Re}_{D,cr} \left[ 1 + 12(D/D_c)^{0.5} \right] = 2300 \times \left[ 1 + 12(0.005 \text{ m}/0.2 \text{ m})^{0.5} \right] = 6664$$

Therefore the flow is laminar and the Nusselt number is given by Eq. 8.76 with Eqs. 8.77.

Continued...



**PROBLEM 9.72 (Cont.)**

$$\overline{\text{Nu}}_{D,c} = \left[ \left( 3.66 + \frac{4.343}{a} \right)^3 + 1.158 \left( \frac{\text{Re}_{D,c} (D/D_c)^{0.5}}{b} \right)^{1.5} \right]^{1/3} \left( \frac{\mu_c}{\mu_s} \right)^{0.14}$$

where

$$a = \left( 1 + \frac{957 (D_c/D)}{\text{Re}_{D,c}^2 \text{Pr}_c} \right) \quad b = 1 + \frac{0.477}{\text{Pr}_c}$$

Substituting numerical values yields  $\overline{\text{Nu}}_{D,c} = 32.8$ , therefore

$$\bar{h}_c = \overline{\text{Nu}}_{D,c} k_c / D = 32.8 \times 0.6193 \text{ W/m} \cdot \text{K} / 0.005 \text{ m} = 4065 \text{ W/m}^2 \cdot \text{K}$$

External free convection,  $\bar{h}_h$  : For the horizontal tube, Eq. 9.34,

$$\overline{\text{Nu}}_{D,h} = \frac{\bar{h}_h D}{k_h} = \left\{ 0.60 + \frac{0.387 \text{Ra}_D^{1/4}}{\left[ 1 + (0.559/\text{Pr})^{9/16} \right]^{8/27}} \right\}^2 \quad (1)$$

with

$$\text{Ra}_{D,h} = \frac{g \beta_h (\bar{T}_s - T_\infty) D^3}{\nu_h \alpha_h} \quad (2)$$

where  $\bar{T}_s$  is the average tube wall temperature determined from the thermal circuit for which

$$\bar{h}_c (\bar{T}_m - \bar{T}_s) = \bar{h}_h (\bar{T}_s - T_\infty) \quad (3)$$

and the average film temperature at which to evaluate properties is

$$\bar{T}_f = (\bar{T}_s + T_\infty) / 2 \quad (4)$$

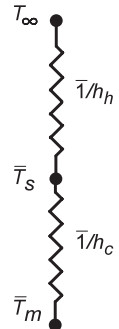

We need to guess a value for  $\bar{T}_s$  and iterate the solution of the system of equations (1-4) and property evaluation until all the equations are satisfied. See Comments 1 and 2.

*Results of the analysis:* Using the foregoing relations in IHT (see Comment 2) the following results were obtained

$$\bar{T}_s = 308.4 \text{ K}, \quad \bar{T}_f = 315.7 \text{ K}, \quad \text{Ra}_D = 7.53 \times 10^4, \quad \bar{h}_h = 1078 \text{ W/m}^2 \cdot \text{K}$$

Then

$$\bar{U} = (1/\bar{h}_c + 1/\bar{h}_h)^{-1} = (1/4065 \text{ W/m}^2 \cdot \text{K} + 1/1078 \text{ W/m}^2 \cdot \text{K})^{-1} = 852 \text{ W/m}^2 \cdot \text{K}$$

$$L = \bar{U} A_s / \bar{U} \pi D = 61.3 \text{ W/K} / 852 \text{ W/m}^2 \cdot \text{K} \times \pi \times 0.005 \text{ m} = 4.58 \text{ m}$$

<

Continued...

**PROBLEM 9.72(Cont.)**

From knowledge of the tube length with the diameter of the coil  $D_c = 200$  mm, the number of coils required is

$$N = \frac{L}{\pi D_c} = \frac{4.58 \text{ m}}{\pi \times 0.200 \text{ m}} = 7.3 \approx 7$$

<

(b) With the length fixed at  $L = 4.58$  m, we can backsolve the foregoing IHT workspace model to find what effect a  $\pm 10\%$  change in the mass flow rate has on the outlet temperature,  $T_{m,o}$ . The results of the analysis are tabulated below.

$\dot{m}$ (kg/s)	0.018	0.02	0.022
$T_{m,o}$ ( $^{\circ}\text{C}$ )	38.8	38.0	37.3

That is, a  $\pm 10\%$  change in the flow rate causes less than a  $\pm 1^{\circ}\text{C}$  change in the outlet temperature. While this change seems quite small, the effect on biological processes can be significant.

**COMMENTS:** (1) For the hot fluid, the Properties section shows the relevant thermophysical properties evaluated at the proper average (rather than a guess value for the film temperature). (2) For the tube  $L/D = 4.58 \text{ m}/0.005 \text{ m} = 916$  which is substantially greater than the entrance length criterion,  $0.05\text{Re}_D = 0.05 \times 6550 = 328$ . Hence, the assumption of fully developed internal flow is justified, especially since the entrance length is shorter in a coiled tube. (3) We are slightly outside of the range for Eq. 8.76, since  $\text{Re}_{D,c}(D/C)^{1/2} = 1036 > 1000$ , but it should give a reasonable estimate. (4) The IHT model for the system can be constructed beginning with the *Rate Equation Tools, Tube Flow, Constant Surface Temperature* along with the *Correlation Tools for Free Convection, Horizontal Cylinder* and the *Properties Tool* for the hot and cold fluids (water). The correlation for the internal flow in a coiled tube must be keyed in by hand. The full set of equations is extensive and very stiff. Review of the IHT Example 8.6 would be helpful in understanding how to organize the complete model.

### PROBLEM 9.73

**KNOWN:** Volume, thermophysical properties, and initial and final temperatures of a pharmaceutical. Diameter and length of submerged tubing. Pressure of saturated steam flowing through the tubing.

**FIND:** (a) Initial rate of heat transfer to the pharmaceutical, (b) Time required to heat the pharmaceutical to 70°C and the amount of steam condensed during the process.

**SCHEMATIC:**

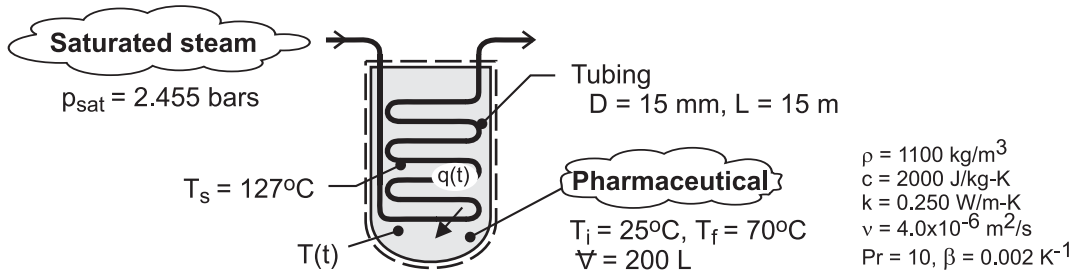

**ASSUMPTIONS:** (1) Pharmaceutical may be approximated as an infinite, quiescent fluid of uniform, but time-varying temperature, (2) Free convection heat transfer from the coil may be approximated as that from a heated, horizontal cylinder, (3) Negligible thermal resistance of condensing steam and tube wall, (4) Negligible heat transfer from tank to surroundings, (5) Constant properties.

**PROPERTIES:** Table A-4, Saturated water (2.455 bars):  $T_{\text{sat}} = 400\text{K} = 127^\circ\text{C}$ ,  $h_{\text{fg}} = 2.183 \times 10^6$  J/kg. Pharmaceutical: See schematic.

**ANALYSIS:** (a) The initial rate of heat transfer is  $q = \bar{h}A_s(T_s - T_i)$ , where  $A_s = \pi DL = 0.707 \text{ m}^2$  and  $\bar{h}$  is obtained from Eq. 9.34. With  $\alpha = \nu/\text{Pr} = 4.0 \times 10^{-7} \text{ m}^2/\text{s}$  and  $\text{Ra}_D = g\beta(T_s - T_i) D^3/\alpha\nu = 9.8 \text{ m/s}^2 (0.002 \text{ K}^{-1}) (102\text{K}) (0.015\text{m})^3/16 \times 10^{-13} \text{ m}^4/\text{s}^2 = 4.22 \times 10^6$ ,

$$\bar{\text{Nu}}_D = \left\{ 0.60 + \frac{0.387 \text{Ra}_D^{1/6}}{\left[ 1 + (0.559/\text{Pr})^{9/16} \right]^{8/27}} \right\}^2 = \left\{ 0.60 + \frac{0.387 (4.22 \times 10^6)^{1/6}}{\left[ 1 + (0.559/10)^{9/16} \right]^{8/27}} \right\}^2 = 27.7$$

Hence,  $\bar{h} = \text{Nu}_D k / D = 27.7 \times 0.250 \text{ W/m} \cdot \text{K} / 0.015\text{m} = 462 \text{ W/m}^2 \cdot \text{K}$

and  $q = \bar{h}A_s(T_s - T_i) = 462 \text{ W/m}^2 \cdot \text{K} \times 0.707 \text{ m}^2 (102^\circ\text{C}) = 33,300 \text{ W} <$

(b) Performing an energy balance at an instant of time for a control surface about the liquid,

$$\frac{d(\rho V c T)}{dt} = q(t) = \bar{h}(t) A_s (T_s - T(t))$$

where the Rayleigh number, and hence  $\bar{h}$ , changes with time due to the change in the temperature of the liquid. Integrating the foregoing equation using the DER function of IHT, the following results are obtained for the variation of  $T$  and  $\bar{h}$  with  $t$ .

Continued ...

**PROBLEM 9.73 (Cont.)**

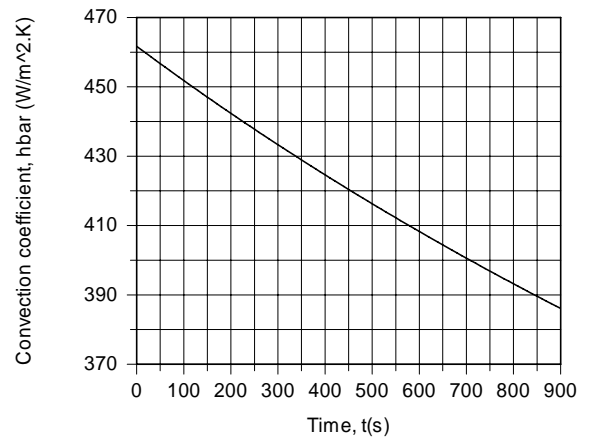
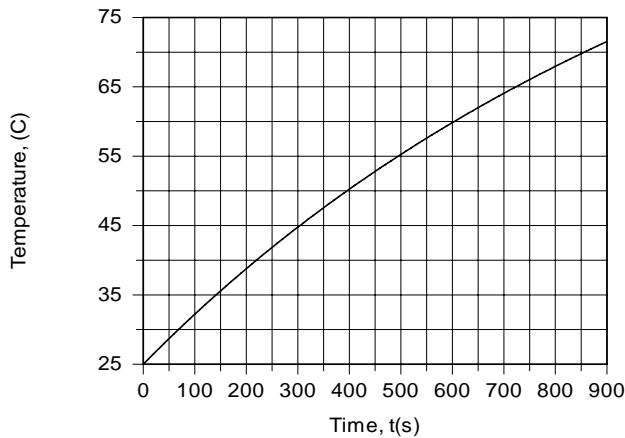

The time at which the liquid reaches 70°C is

$$t_f \approx 855 \text{ s}$$

<

The temperature increases at a decreasing rate due to the corresponding reduction in  $(T_s - T)$ , and hence reductions in  $Ra_D$ ,  $\bar{h}$  and  $q$ . The Rayleigh number decreases from  $4.22 \times 10^6$  to  $2.16 \times 10^6$ , while the heat rate decreases from 33,300 to 14,000 W. The convection coefficient decreases approximately as  $(T_s - T)^{1/3}$ , while  $q \sim (T_s - T)^{4/3}$ . The latent energy released by the condensed steam corresponds to the increase in thermal energy of the pharmaceutical. Hence,  $m_c h_{fg} = \rho \forall c (T_f - T_i)$ , and

$$m_c = \frac{\rho \forall c (T_f - T_i)}{h_{fg}} = \frac{1100 \text{ kg/m}^3 \times 0.2 \text{ m}^3 \times 2000 \text{ J/kg} \cdot \text{K} \times 45^\circ\text{C}}{2.183 \times 10^6 \text{ J/kg}} = 9.07 \text{ kg}$$

<

**COMMENTS:** (1) Over such a large temperature range, the fluid properties are likely to vary significantly, particularly  $\nu$  and Pr. A more accurate solution could therefore be performed if the temperature dependence of the properties were known. (2) Condensation of the steam is a significant process expense, which is linked to the equipment (capital) and energy (operating) costs associated with steam production.

## PROBLEM 9.74

**KNOWN:** Fin of uniform cross section subjected to prescribed conditions.

**FIND:** Tip temperature and fin effectiveness based upon (a) *average* values for free convection and radiation coefficients and (b) *local* values using a numerical method of solution.

**SCHEMATIC:**

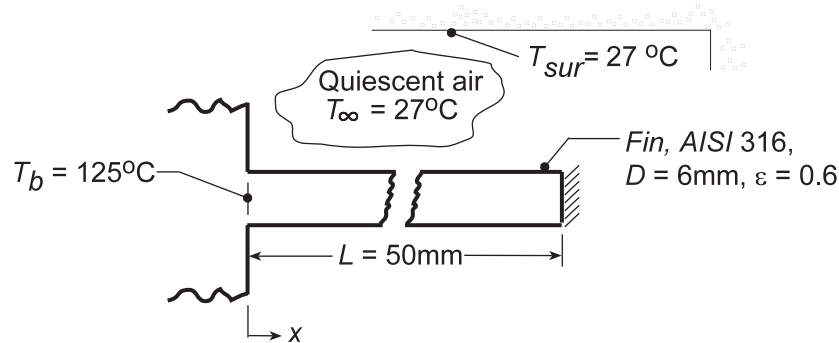

**ASSUMPTIONS:** (1) Steady-state conditions, (2) Surroundings are isothermal and large compared to the fin, (3) One-dimensional conduction in fin, (4) Constant fin properties, (5) Tip of fin is insulated, (6) Fin surface is diffuse-gray.

**PROPERTIES:** Table A-4, Air ( $T_f = 325$  K, 1 atm):  $\nu = 18.41 \times 10^{-6}$  m<sup>2</sup>/s,  $k = 0.0282$  W/m·K,  $\alpha = 26.2 \times 10^{-6}$  m<sup>2</sup>/s,  $Pr = 0.704$ ,  $\beta = 1/T_f = 3.077 \times 10^{-3}$  K<sup>-1</sup>; Table A-1, Steel AISI 316 ( $\bar{T}_s = 350$  K):  $k = 14.3$  W/m·K.

**ANALYSIS:** (a) *Average value*  $\bar{h}_c$  and  $\bar{h}_r$ : From Table 3.4 for a fin of constant cross section with an insulated tip and constant heat transfer coefficient  $\bar{h}$ , the tip temperature ( $x = L$ ) is given by Eq. 3.80,

$$\theta_L = \theta_b \frac{\cosh m(L-x)}{\cosh mL} = \theta_b / \cosh(mL) \quad m = (\bar{h}P/kA_c)^{1/2} \quad (1,2)$$

where  $\theta_L = T_L - T_\infty$  and  $\theta_b = T_b - T_\infty$ . For this situation, the average heat transfer coefficient is

$$\bar{h} = \bar{h}_c + \bar{h}_r \quad (3)$$

and is evaluated at the average temperature of the fin. The fin effectiveness  $\varepsilon_f$  follows from Eqs. 3.81 and 3.86

$$\varepsilon_f \equiv q_f / \bar{h}A_{c,b}\theta_b, \quad q_f = M \cdot \tanh(mL), \quad M = (\bar{h}PkA_c)^{1/2} \theta_b. \quad (4,5,6)$$

To estimate the coefficients, assume a value of  $\bar{T}_s$ ; the lowest  $\bar{T}_s$  occurs when the tip reaches  $T_\infty$ . That is,

$$\bar{T}_s = (\bar{T}_\infty + T_b) / 2 = (27 + 125)^\circ \text{C} / 2 = 76^\circ \text{C} \approx 350 \text{ K}$$

$$T_f = (\bar{T}_s + T_\infty) / 2 = 325 \text{ K}.$$

The free convection coefficient can be estimated from Eq. 9.33,

$$\overline{Nu}_D = \frac{\bar{h}_c D}{k} = C Ra_D^n \quad (7)$$

$$Ra_D = \frac{g\beta\Delta T D^3}{\nu\alpha} = \frac{9.8 \text{ m/s}^2 \times 3.077 \times 10^{-3} \text{ K}^{-1} (350 - 300) \text{ K} (0.006 \text{ m})^3}{18.41 \times 10^{-6} \text{ m}^2/\text{s} \times 26.2 \times 10^{-6} \text{ m}^2/\text{s}} = 675$$

and from Table 9.1 with  $10^2 < Ra_L < 10^4$ ,  $C = 0.850$  and  $n = 0.188$ . Hence

Continued...

**PROBLEM 9.74 (Cont.)**

$$\bar{h}_c = \frac{0.0282 \text{ W/m} \cdot \text{K}}{0.006 \text{ m}} \times 0.850 (675)^{0.188} = 13.6 \text{ W/m}^2 \cdot \text{K}. \quad (8)$$

The radiation coefficient is estimated from Eq. 1.9,

$$\begin{aligned} \bar{h}_r &= \varepsilon \sigma (\bar{T}_s + T_{\text{sur}}) (\bar{T}_s^2 + T_{\text{sur}}^2) \\ \bar{h}_r &= 0.6 \times 5.67 \times 10^{-8} \text{ W/m}^2 \cdot \text{K}^4 (350 + 300) (350^2 + 300^2) \text{ K}^3 = 4.7 \text{ W/m}^2 \cdot \text{K} \end{aligned} \quad (9)$$

Hence, the average coefficient, Eq. (3), is

$$\bar{h} = (13.6 + 4.7) \text{ W/m}^2 \cdot \text{K} = 18.3 \text{ W/m}^2 \cdot \text{K}.$$

Evaluate the fin parameters, Eq. (2) and (6) with

$$\begin{aligned} P &= \pi D = \pi \times 0.006 \text{ m} = 1.885 \times 10^{-2} \text{ m} & A_c &= \pi D^2/4 = \pi (0.006 \text{ m})^2/4 = 2.827 \times 10^{-5} \text{ m}^2 \\ m &= \left( 18.3 \text{ W/m}^2 \cdot \text{K} \times 1.885 \times 10^{-2} \text{ m} / 14.3 \text{ W/m} \cdot \text{K} \times 2.827 \times 10^{-5} \text{ m}^2 \right)^{1/2} = 29.21 \text{ m}^{-1} \\ M &= \left( 18.3 \text{ W/m}^2 \cdot \text{K} \times 1.885 \times 10^{-2} \text{ m} \times 14.3 \text{ W/m} \cdot \text{K} \times 2.827 \times 10^{-5} \text{ m}^2 \right)^{1/2} (125 - 27) \text{ K} = 1.157 \text{ W}. \end{aligned}$$

From Eq. (1), the tip temperature is

$$\theta_L = T_L - T_b = (125 - 27) \text{ K} / \cosh(29.21 \text{ m}^{-1} \times 0.050 \text{ m}) = 43.2 \text{ K} \quad T_L = 70.2^\circ \text{C} = 343 \text{ K}. <$$

Note this value of  $T_L$  provides for  $\bar{T}_s \approx 370 \text{ K}$ ; so we underestimated  $\bar{T}_s$ . For best results, an iteration is warranted. The fin effectiveness, Eqs. (4) and (5), is

$$\begin{aligned} q_f &= 1.157 \text{ W} \tanh(29.21 \text{ m}^{-1} \times 0.050 \text{ m}) = 1.039 \text{ W} \\ \varepsilon_f &= 1.039 \text{ W} / 18.3 \text{ W/m}^2 \cdot \text{K} \times 2.827 \times 10^{-5} \text{ m}^2 (125 - 27) \text{ K} = 20.5. < \end{aligned}$$

(b) *Local values  $h_c$  and  $h_r$ :* Consider the nodal arrangement for using a numerical method to find the tip temperature  $T_L$ , the heat rate  $q_f$ , and the fin effectiveness  $\varepsilon$ .

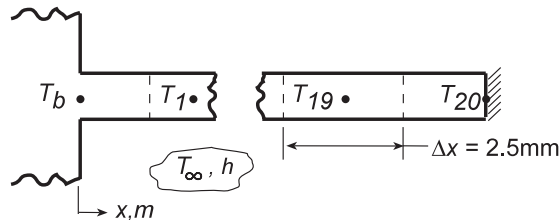

From an energy balance on a control volume about node m, the finite-difference equation is of the form

$$T_m = \left[ T_{m+1} + T_{m-1} + (h_c + h_r) (4\Delta x^2/kD) T_\infty \right] / \left[ 2 + (h_r + h_c) (4\Delta x^2/kD) \right]. \quad (10)$$

The local coefficient  $h_c$  follows from Eq. (3), with Eq. 9.33, yielding

$$\begin{aligned} h_c &= \frac{k}{D} \text{CRa}_D^n \\ h_c &= \frac{0.0282 \text{ W/m} \cdot \text{K}}{0.006 \text{ m}} \times 0.850 \left( 675 \left[ \Delta T / (350 - 300) \right] \right)^{0.188} = 6.517 (T_m - 300)^{0.188}. \end{aligned} \quad (11)$$

The local coefficient  $h_r$  follows from Eq. (9),

$$h_r = 0.6 \times 5.67 \times 10^{-8} \text{ W/m}^2 \cdot \text{K}^4 (T_m + 300) (T_m^2 + 300^2) \quad \text{Continued...}$$

**PROBLEM 9.74 (Cont.)**

$$h_r = 3.402 \times 10^{-8} (T_m + 300) (T_m^2 + 300^2). \quad (12)$$

The 20-node system of finite-difference equations based upon Eq. (10) with the variable coefficients  $h_c$  and  $h_r$  prescribed Eqs. (11) and (12), respectively, can be solved simultaneously using IHT or another approach. The temperature distribution is

Node	$T_m$ (K)	Node	$T_m$ (K)	Node	$T_m$ (K)	Node	$T_m$ (K)
1	391.70	6	367.61	11	353.02	16	345.49
2	385.95	7	364.03	12	351.00	17	344.70
3	380.70	8	360.81	13	349.25	18	344.15
4	375.92	9	357.91	14	347.75	19	343.82
5	371.56	10	355.32	15	346.50	20	343.71

From these results the tip temperature is

$$T_L = T_{fd} = 343.7 \text{ K} = 70.7^\circ \text{ C}.$$

<

The fin heat rate follows from an energy balance for the control surface about node b.

$$q_f = q_{conv} + q_{cond}$$

$$q_f = h_b P \frac{\Delta x}{2} (T_b - T_\infty) + k A_c \frac{T_b - T_1}{\Delta x}$$

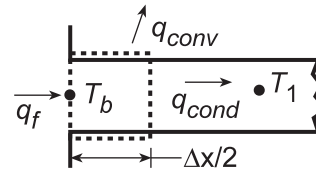

where  $h_b$  follows from Eqs. (11) and (12), with  $T_b = 125^\circ \text{ C} = 398 \text{ K}$ ,

$$h_b = 6.517 (398 - 300)^{0.188} + 3.402 \times 10^{-8} (398 + 300) (398^2 + 300^2) = 21.33 \text{ W/m}^2 \cdot \text{K}$$

$$q_f = 21.33 \text{ W/m}^2 \cdot \text{K} \times 1.855 \times 10^{-2} \text{ m} (0.0025 \text{ m}/2) (398 - 300) \text{ K}$$

$$+ 14.3 \text{ W/m} \cdot \text{K} \times 2.827 \times 10^{-5} \text{ m}^2 \frac{(398 - 391.70) \text{ K}}{0.0025 \text{ m}} = (0.049 + 1.018) \text{ W} = 1.067 \text{ W}.$$

The effectiveness follows from Eq. (4)

$$\varepsilon_f = 1.067 \text{ W} / 21.33 \text{ W/m}^2 \cdot \text{K} \times 2.827 \times 10^{-5} \text{ m}^2 (125 - 27) \text{ K} = 18.1$$

**COMMENTS:** (1) The results by the two methods of solution compare as follows:

Coefficients	$T(L)$ ,K	$q_f$ (W)	$\varepsilon_f$
average	343.1	1.039	20.5
local	343.7	1.067	18.1

The temperature predictions are in excellent agreement and the heat rates very close, within 4%.

(2) To obtain the finite-different equation for node  $n = 20$ , use Eq. (10) but consider the adiabatic surface as a symmetry plane.

### PROBLEM 9.75

**KNOWN:** Horizontal tubes of different shapes each of the same cross-sectional area transporting a hot fluid in quiescent air. Lienhard correlation for immersed bodies.

**FIND:** Tube shape which has the minimum heat loss to the ambient air by free convection.

**SCHEMATIC:**

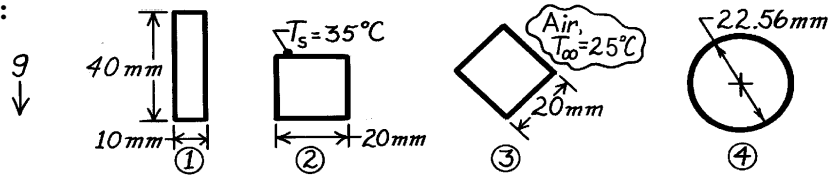

**ASSUMPTIONS:** (1) Ambient air is quiescent, (2) Negligible heat loss by radiation, (3) All shapes have the same cross-sectional area and uniform surface temperature.

**PROPERTIES:** Table A-4, Air ( $T_f \approx 300\text{K}$ , 1 atm):  $\nu = 15.89 \times 10^{-6} \text{ m}^2/\text{s}$ ,  $\alpha = 22.5 \times 10^{-6} \text{ m}^2/\text{s}$ ,  $k = 0.0263 \text{ W/m}\cdot\text{K}$ ,  $\text{Pr} = 0.707$ ,  $\beta = 1/T_f$ .

**ANALYSIS:** The Lienhard correlation approximates the laminar convection coefficient for an immersed body on which the boundary layer does not separate from the surface by  $\overline{\text{Nu}}_\ell = (\overline{h}\ell)/k = 0.52\text{Ra}_\ell^{1/4}$ , where the characteristic length,  $\ell$ , is the length of travel of the fluid in the boundary layer across the shape surface. The heat loss per unit length from any shape is  $q' = \overline{h}P(T_s - T_\infty)$ . For the shapes,

$$\text{Ra}_\ell = \frac{g\beta\Delta T\ell^3}{\nu\alpha} = \frac{9.8 \text{ m/s}^2 (1/300 \text{ K})(35 - 25) \text{ K} \ell^3 \text{ m}^3}{15.89 \times 10^{-6} \text{ m}^2/\text{s} \times 22.5 \times 10^{-6} \text{ m}^2/\text{s}} = 9.137 \times 10^8 \ell^3$$

$$\overline{h}_\ell = (0.0263 \text{ W/m}\cdot\text{K} / \ell) 0.52 \left( 9.137 \times 10^8 \ell^3 \right)^{1/4} = 2.378 \ell^{-1/4}$$

For the shapes,  $\ell$  is half the total wetted perimeter  $P$ . Evaluating  $\overline{h}_\ell$  and  $q'$ , find

Shape	$P$ (mm)	$\ell$ (mm)	$\overline{h}_\ell$ ( $\text{W/m}^2 \cdot \text{K}$ )	$q'$ ( $\text{W/m}$ )
1	$2 \times 40 + 2 \times 10 = 100$	50	5.03	5.03
2	$4 \times 20 = 80$	40	5.32	4.26
3	$4 \times 20 = 80$	40	5.32	4.26
4	$\pi \times 22.56 = 70.9$	35.4	5.48	3.89

Hence, it follows that shape 4 has the minimum heat loss. <

**COMMENTS:** Using the Lienhard correlation for a sphere of  $D = 22.56 \text{ mm}$ , find  $\ell = 35.4 \text{ mm}$ , the same as for a cylinder, namely,  $h_4 = 5.48 \text{ W/m}^2 \cdot \text{K}$ . Using the Churchill correlation, Eq. 9.35, find  $\overline{h} = 7.69 \text{ W/m}^2 \cdot \text{K}$ . Hence, the approximation for the sphere is 29% low. For a cylinder, using Eq. 9.34, find  $\overline{h} = 5.15 \text{ W/m}^2 \cdot \text{K}$ . The approximation for the cylinder is 6% high.



## PROBLEM 9.76

**KNOWN:** Sphere of 2-mm diameter immersed in a fluid at 300 K.

**FIND:** (a) The conduction limit of heat transfer from the sphere to the quiescent, extensive fluid,  $Nu_{D,cond} = 2$ ; (b) Considering free convection, surface temperature at which the Nusselt number is twice that of the conduction limit for the fluids air and water; and (c) Considering forced convection, fluid velocity at which the Nusselt number is twice that of the conduction limit for the fluids air and water.

**SCHEMATIC:**

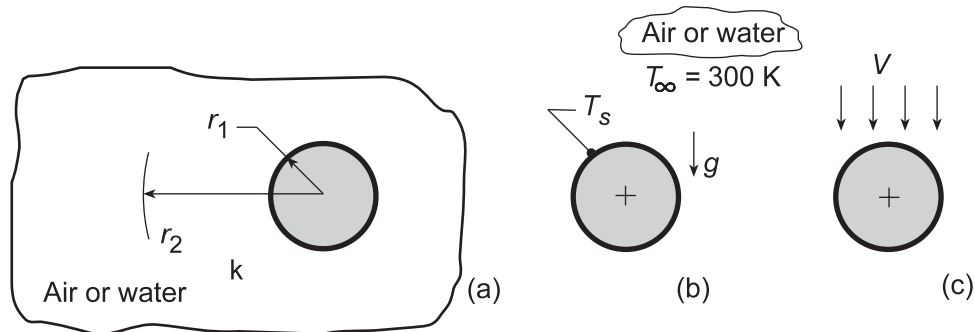

**ASSUMPTIONS:** (1) Sphere is isothermal, (2) For part (a), fluid is stationary, and (3) For part (b), fluid is quiescent, extensive.

**ANALYSIS:** (a) Following the hint provided in the problem statement, the thermal resistance of a hollow sphere, Eq. 3.40 of inner and outer radii,  $r_1$  and  $r_2$ , respectively, and thermal conductivity  $k$ , is

$$R_{t,cond} = \frac{1}{4\pi k} \left( \frac{1}{r_1} - \frac{1}{r_2} \right) \quad (1)$$

and as  $r_2 \rightarrow \infty$ , that is the medium is extensive

$$R_{t,cond} = \frac{1}{4\pi k r_1} = \frac{1}{2\pi k D} \quad (2)$$

The Nusselt number can be expressed as

$$Nu = \frac{hD}{k} \quad (3)$$

and the conduction resistance in terms of a convection coefficient is

$$R_{t,cond} = \frac{1}{hA_s} = \frac{1}{h\pi D^2} \quad (4)$$

Combining Eqs. (3) and (4)

$$Nu_{D,cond} = \frac{\left(1/R_{t,cond}\pi D^2\right)D}{k} = \frac{\left[1/(1/2\pi k D)\left(\pi D^2\right)\right]D}{k} = 2 \quad <$$

(b) For free convection, the recommended correlation, Eq. 9.35, is

$$\overline{Nu}_D = 2 + \frac{0.589 Ra_D^{1/4}}{\left[1 + (0.469/Pr)^{9/16}\right]^{4/9}}$$

Continued...

**PROBLEM 9.76 (Cont.)**

$$Ra_D = \frac{g\beta\Delta T D^3}{\nu\alpha} \quad \Delta T = T_s - T_\infty$$

where properties are evaluated at  $T_f = (T_s + T_\infty) / 2$ . What value of  $T_s$  is required for  $\overline{Nu}_D = 4$  for the fluids air and water? Using the *IHT Correlations Tool, Free Convection, Sphere* and the *Properties Tool* for *Air* and *Water*, find

*Air:*  $\overline{Nu} \leq 3.1$  for all  $T_s > 300$  <

*Water:*  $T_s = 301.1\text{K}$  <

(c) For forced convection, the recommended correlation, Eq. 7.56, is

$$\overline{Nu}_D = 2 + \left(0.4 Re_D^{1/2} + 0.06 Re_D^{2/3}\right) Pr^{0.4} (\mu/\mu_s)^{1/4}$$

$$Re_D = VD/\nu$$

where properties are evaluated at  $T_\infty$ , except for  $\mu_s$  evaluated at  $T_s$ . What value of  $V$  is required for  $\overline{Nu}_D = 4$  if the fluids are air and water? Using the *IHT Correlations Tool, Forced Convection, Sphere* and the *Properties Tool* for *Air* and *Water*, find (evaluating all properties at 300 K)

*Air:*  $V = 0.17 \text{ m/s}$       *Water:*  $V = 0.00185 \text{ m/s}$  <

**COMMENTS:** (1) For water,  $\overline{Nu}_D = 2 \times \overline{Nu}_{D,\text{cond}}$  can be achieved by  $\Delta T \approx 1$  for free convection and with very low velocity,  $V < 0.002 \text{ m/s}$ , for forced convection.

(2) For air,  $\overline{Nu}_D = 2 \times \overline{Nu}_{D,\text{cond}}$  can be achieved in forced convection with low velocities,  $V < 0.2 \text{ m/s}$ . In free convection,  $\overline{Nu}_D$  increases with increasing  $T_s$  and reaches a maximum,  $\overline{Nu}_{D,\text{max}} = 3.1$ , around 450 K. Why is this so? Hint: Plot  $Ra_D$  as a function of  $T_s$  and examine the role of  $\beta$  and  $\Delta T$  as a function of  $T_s$ .

### PROBLEM 9.77

**KNOWN:** Sphere with embedded electrical heater is maintained at a uniform surface temperature when suspended in various media.

**FIND:** Required electrical power for these media: (a) atmospheric air, (b) water, (c) ethylene glycol.

**SCHEMATIC:**

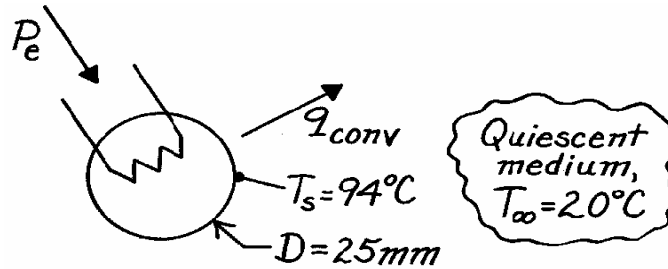

**ASSUMPTIONS:** (1) Negligible surface radiation effects, (2) Extensive and quiescent media.

**PROPERTIES:** Evaluated at  $T_f = (T_s + T_\infty)/2 = 330\text{K}$ :

	$\nu \cdot 10^6, \text{m}^2/\text{s}$	$k \cdot 10^3, \text{W/m}\cdot\text{K}$	$\alpha \cdot 10^6, \text{m}^2/\text{s}$	Pr	$\beta \cdot 10^3, \text{K}^{-1}$
Table A-4, Air (1 atm)	18.91	28.5	26.9	0.711	3.03
Table A-6, Water	0.497	650	0.158	3.15	0.504
Table A-5, Ethylene glycol	5.15	260	0.0936	55.0	0.65

**ANALYSIS:** The electrical power ( $P_e$ ) required to offset convection heat transfer is

$$q_{\text{conv}} = \bar{h} A_s (T_s - T_\infty) = \pi \bar{h} D^2 (T_s - T_\infty). \quad (1)$$

The free convection heat transfer coefficient for the sphere can be estimated from Eq. 9.35 using Eq. 9.25 to evaluate  $Ra_D$ .

$$\bar{Nu}_D = 2 + \frac{0.589 Ra_D^{1/4}}{\left[1 + (0.469/Pr)^{9/16}\right]^{4/9}} \begin{cases} Pr \geq 0.7 \\ Ra_D \leq 10^{11} \end{cases} \quad Ra_D = \frac{g \beta \Delta T D^3}{\nu \alpha}. \quad (2,3)$$

(a) For air

$$Ra_D = \frac{9.8 \text{m/s}^2 \left(3.03 \times 10^{-3} \text{K}^{-1}\right) (94 - 20) \text{K} (0.025 \text{m})^3}{18.91 \times 10^{-6} \text{m}^2/\text{s} \times 26.9 \times 10^{-6} \text{m}^2/\text{s}} = 6.750 \times 10^4$$

$$\bar{h}_D = \frac{k}{D} \bar{Nu}_D = \frac{0.0285 \text{W/m}\cdot\text{K}}{0.025 \text{m}} \left\{ 2 + \frac{0.589 \left(6.750 \times 10^4\right)^{1/4}}{\left[1 + (0.469/0.711)^{9/16}\right]^{4/9}} \right\} = 10.6 \text{W/m}^2 \cdot \text{K}$$

$$q_{\text{conv}} = \pi \times 10.6 \text{W/m}^2 \cdot \text{K} (0.025 \text{m})^2 (94 - 20) \text{K} = 1.55 \text{W}.$$

Continued ...

**PROBLEM 9.77 (Cont.)**

(b,c) Summary of the calculations above and for water and ethylene glycol:

Fluid	$Ra_D$	$\bar{h}_D \left( W / m^2 \cdot K \right)$	$q(W)$	
Air	$6.750 \times 10^4$	10.6	1.55	<
Water	$7.273 \times 10^7$	1299	187	<
Ethylene glycol	$15.82 \times 10^6$	393	57.0	<

**COMMENTS:** Note large differences in the coefficients and heat rates for the fluids.

## PROBLEM 9.78

**KNOWN:** Temperatures and spacing of vertical, isothermal plates.

**FIND:** (a) Shape of velocity distribution, (b) Forms of mass, momentum and energy equations for laminar flow, (c) Expression for the temperature distribution, (d) Vertical pressure gradient, (e) Expression for the velocity distribution.

**SCHEMATIC:**

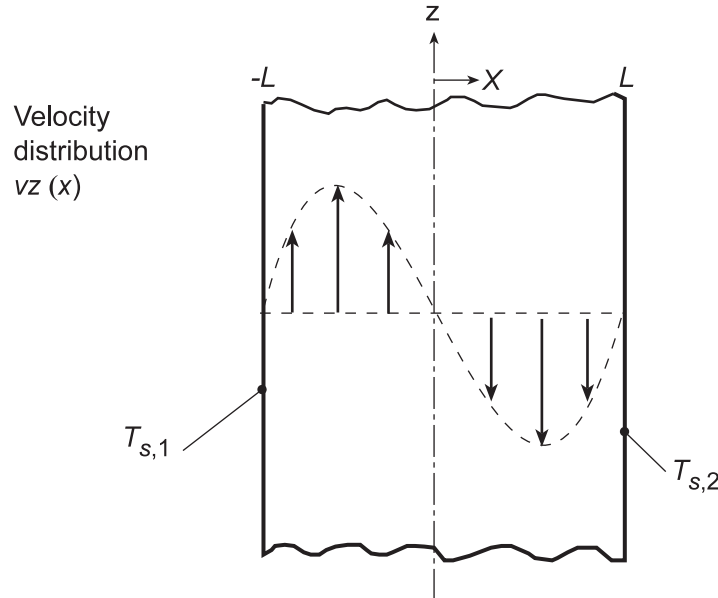

**ASSUMPTIONS:** (1) Laminar, incompressible, fully-developed flow, (2) Constant properties, (3) Negligible viscous dissipation, (4) Boussinesq approximation.

**ANALYSIS:** (a) For the prescribed conditions, there must be buoyancy driven ascending and descending flows along the surfaces corresponding to  $T_{s,1}$  and  $T_{s,2}$ , respectively (see schematic). However, conservation of mass dictates equivalent rates of *upflow* and *downflow* and, assuming constant properties, inverse symmetry of the velocity distribution about the midplane.

(b) For fully-developed flow, which is achieved for *long* plates,  $v_x = 0$  and the continuity equation yields

$$\frac{\partial v_z}{\partial z} = 0 \quad <$$

With both surface temperatures independent of  $z$ , the fully-developed temperature distribution will also have  $\partial T / \partial z = 0$ . Hence, there is no net transfer of momentum or energy by advection, and the corresponding equations are, respectively,

$$0 = -\left(\frac{dp}{dz}\right) + \mu \left(\frac{d^2 v_z}{dx^2}\right) - \rho(g/g_c) \quad <$$

$$0 = (dT^2/dx^2) \quad <$$

(c) Integrating the energy equation twice, we obtain

$$T = C_1 x + C_2$$

and applying the boundary conditions,  $T(-L) = T_{s,1}$  and  $T(L) = T_{s,2}$ , it follows that  $C_1 = -(T_{s,1} - T_{s,2})/2L$  and  $C_2 = (T_{s,1} + T_{s,2})/2 \equiv T_m$ , in which case,

$$\frac{T - T_m}{T_{s,1} - T_{s,2}} = -\frac{x}{2L} \quad <$$

Continued...

### PROBLEM 9.78 (Cont.)

(d) From hydrostatic considerations and the assumption of a constant density  $\rho_m$ , the balance between the gravitational and net pressure forces may be expressed as  $dp/dz = -\rho_m(g/g_c)$ . The momentum equation is then of the form

$$0 = \mu \left( d^2 v_z / dx^2 \right) - (\rho - \rho_m) (g/g_c)$$

or, invoking the Boussinesq approximation,  $\rho - \rho_m \approx -\beta \rho_m (T - T_m)$ ,

$$d^2 v_z / dx^2 = -(\beta \rho_m / \mu) (g/g_c) (T - T_m)$$

or, from the known temperature distribution,

$$d^2 v_z / dx^2 = (\beta \rho_m / 2\mu) (g/g_c) (T_{s,1} - T_{s,2}) (x/L) \quad <$$

(e) Integrating the foregoing expression, we obtain

$$dv_z / dx = (\beta \rho_m / 4\mu) (g/g_c) (T_{s,1} - T_{s,2}) \left( x^2 / L \right) + C_1$$

$$v_z = (\beta \rho_m / 12\mu) (g/g_c) (T_{s,1} - T_{s,2}) \left( x^3 / L \right) + C_1 x + C_2$$

Applying the boundary conditions  $v_z(-L) = v_z(L) = 0$ , it follows that  $C_1 = -(\beta \rho_m / 12\mu) (g/g_c) (T_{s,1} - T_{s,2}) L$  and  $C_2 = 0$ . Hence,

$$v_z = \left( \beta \rho_m L^2 / 12\mu \right) (g/g_c) (T_{s,1} - T_{s,2}) \left[ \left( x^3 / L^3 \right) - (x/L) \right] \quad <$$

**COMMENTS:** The validity of assuming fully-developed conditions improves with increasing plate length and would be satisfied precisely for infinite plates.

### PROBLEM 9.79

**KNOWN:** Dimensions of vertical rectangular fins. Temperature of fins and quiescent air.

**FIND:** Optimum fin spacing and corresponding fin heat transfer rate.

**SCHEMATIC:**

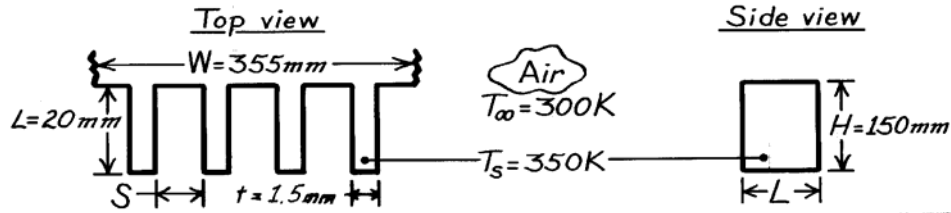

**ASSUMPTIONS:** (1) Isothermal fins, (2) Negligible radiation, (3) Quiescent air, (4) Negligible heat transfer from fin tips, (5) Negligible radiation.

**PROPERTIES:** Table A-4, Air ( $T_f = 325\text{K}$ , 1 atm):  $\nu = 18.41 \times 10^{-6} \text{ m}^2/\text{s}$ ,  $k = 0.0282 \text{ W/m}\cdot\text{K}$ ,  $\alpha = 26.1 \times 10^{-6} \text{ m}^2/\text{s}$ ,  $\text{Pr} = 0.703$ .

**ANALYSIS:** From Table 9.3

$$S_{\text{opt}} = 2.71 \left( \text{Ra}_S / S^3 H \right)^{-1/4} = 2.71 \left[ \frac{g\beta(T_s - T_\infty)}{\alpha\nu H} \right]^{-1/4}$$

$$S_{\text{opt}} = 2.71 \left[ \frac{9.8 \text{ m/s}^2 (325 \text{ K})^{-1} (50 \text{ K})}{26.1 \times 10^{-6} \text{ m}^2/\text{s} \times 18.4 \times 10^{-6} \text{ m}^2/\text{s} \times 0.15 \text{ m}} \right]^{-1/4} = 7.12 \text{ mm} \quad <$$

From Eq. 9.45 and Table 9.3

$$\overline{\text{Nu}}_S = \left[ \frac{576}{(\text{Ra}_S S/L)^2} + \frac{2.87}{(\text{Ra}_S S/L)^{1/2}} \right]^{-1/2}$$

$$\text{Ra}_S (S/L) = \frac{g\beta(T_s - T_\infty) S^4}{\alpha\nu H} = \frac{9.8 \text{ m/s}^2 (325 \text{ K})^{-1} (50 \text{ K}) (7.12 \times 10^{-3} \text{ m})^4}{25.4 \times 10^{-6} \text{ m}^2/\text{s} \times 18.4 \times 10^{-6} \text{ m}^2/\text{s} \times 0.15 \text{ m}}$$

$$\text{Ra}_S (S/L) = 53.2$$

$$\overline{\text{Nu}}_S = \left[ \frac{576}{(53.2)^2} + \frac{2.87}{(53.2)^{1/2}} \right]^{-1/2} = [0.204 + 0.393]^{-1/2} = 1.29$$

$$\bar{h} = \overline{\text{Nu}}_S k / S = 1.29 (0.0282 \text{ W/m}\cdot\text{K} / 0.00712 \text{ m}) = 5.13 \text{ W/m}^2 \cdot \text{K}$$

With  $N = W/(t + S) = (355 \text{ mm}) / (8.62 \times 10^{-3} \text{ m}) = 41.2 \approx 41$ ,

$$q = 2N\bar{h}(L \times H)(T_s - T_\infty) = 82 (5.13 \text{ W/m}^2 \cdot \text{K}) (0.02 \text{ m} \times 0.15 \text{ m}) 50 \text{ K}$$

$$q = 63.1 \text{ W} \quad <$$

**COMMENTS:**  $S_{\text{opt}} = 7.12 \text{ mm}$  is considerably less than the value of 34 mm predicted from previous considerations. Hence, the corresponding value of  $q = 63.1 \text{ W}$  is considerably larger than that of the previous prediction.

### PROBLEM 9.80

**KNOWN:** Length, width and spacing of vertical circuit boards. Maximum allowable board temperature.

**FIND:** Maximum allowable power dissipation per board.

**SCHEMATIC:**

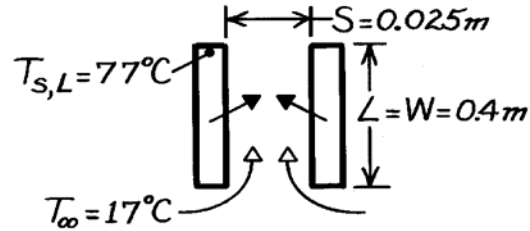

**ASSUMPTIONS:** (1) Circuit boards are flat with uniform heat flux at each surface, (2) Negligible radiation.

**PROPERTIES:** Table A-4, Air ( $\bar{T} = 320\text{K}$ , 1 atm):  $\nu = 17.9 \times 10^{-6} \text{ m}^2/\text{s}$ ,  $k = 0.0278 \text{ W/m}\cdot\text{K}$ ,  $\alpha = 25.5 \times 10^{-6} \text{ m}^2/\text{s}$ .

**ANALYSIS:** From Eqs. 9.41 and 9.46 and Table 9.3,

$$\frac{q_s''}{T_{s,L} - T_{\infty}} \frac{S}{k} = \left[ \frac{48}{\text{Ra}_S^* S/L} + \frac{2.51}{(\text{Ra}_S^* S/L)^{2/5}} \right]^{-1/2}$$

where 
$$\text{Ra}_S^* \frac{S}{L} = \frac{g\beta q_s'' S^5}{k\alpha\nu L} = \frac{9.8 \text{ m/s}^2 (320 \text{ K})^{-1} (0.025 \text{ m})^5 q_s''}{0.0278 \text{ W/m}\cdot\text{K} (25.5 \times 10^{-6} \text{ m}^2/\text{s}) (17.9 \times 10^{-6} \text{ m}^2/\text{s}) 0.4 \text{ m}}$$

$$\text{Ra}_S^* \frac{S}{L} = 58.9 q_s''$$

and 
$$\frac{q_s''}{T_{s,L} - T_{\infty}} \frac{S}{k} = \frac{0.025 \text{ m} \cdot q_s''}{(60 \text{ K}) 0.0278 \text{ W/m}\cdot\text{K}} = 0.015 q_s''.$$

Hence, 
$$0.015 q_s'' = \left[ \frac{0.815}{q_s''} + \frac{0.492}{(q_s'')^{0.4}} \right]^{-1/2}.$$

A trial-and-error solution yields

$$q_s'' = 287 \text{ W/m}^2.$$

Hence, 
$$q = 2A_s q_s'' = 2(0.4 \text{ m})^2 (287 \text{ W/m}^2) = 91.8 \text{ W.} \quad <$$

**COMMENTS:** Larger heat rates may be achieved by using a fan to superimpose a forced flow on the buoyancy driven flow.



## PROBLEM 9.81

**KNOWN:** Dimensions of window and gap between window and insulation. Temperature of window and surrounding air.

**FIND:** (a) Heat loss through the window and associated weekly cost, (b) Heat loss through window as a function of gap spacing.

**SCHEMATIC:**

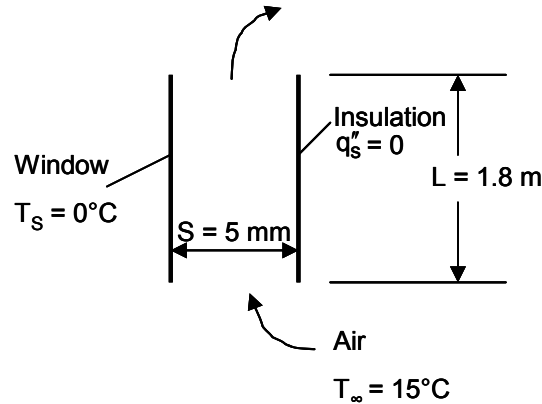

**ASSUMPTIONS:** (1) Negligible radiation heat loss. (2) Insulation creates adiabatic condition.

**PROPERTIES:** Table A-4, Air (assumed  $\bar{T} = 7^\circ\text{C} = 280\text{ K}$ ):  $\nu = 14.11 \times 10^{-6}\text{ m}^2/\text{s}$ ,  $k = 0.0247\text{ W/m}\cdot\text{K}$ ,  $\alpha = 19.9 \times 10^{-6}\text{ m}^2/\text{s}$ ,  $\beta = 1/\bar{T} = 0.0036\text{ K}^{-1}$ .

**ANALYSIS:**

(a) This is a case of free convection in a vertical parallel plate channel. The window can be approximated as isothermal and the insulation can be modeled as adiabatic. Therefore we can use Equation 9.45 to find the average Nusselt number, with  $C_1 = 144$ ,  $C_2 = 2.87$  in Table 9.3. We begin by calculating the Rayleigh number from Equation 9.38:

$$Ra_S = \frac{g \beta |T_s - T_\infty| S^3}{\alpha \nu} \quad (1)$$

$$Ra_S = \frac{9.8\text{ m/s}^2 \times 0.0036\text{ K}^{-1} \times |0^\circ\text{C} - 15^\circ\text{C}| \times (0.005\text{ m})^3}{19.9 \times 10^{-6}\text{ m}^2/\text{s} \times 14.11 \times 10^{-6}\text{ m}^2/\text{s}} = 234$$

Then

$$\bar{Nus} = \left[ \frac{C_1}{(Ra_S S/L)^2} + \frac{C_2}{(Ra_S S/L)^{1/2}} \right]^{-1/2} \quad (2)$$

$$\bar{Nus} = \left[ \frac{144}{(234 \times 0.005\text{ m}/1.8\text{ m})^2} + \frac{2.87}{(234 \times 0.005\text{ m}/1.8\text{ m})^{1/2}} \right]^{-1/2} = 0.0538$$

From Equation 9.37 (noting that heat transfer is in the direction from the air to the surface)

$$\begin{aligned} q &= \bar{Nus} k A (T_\infty - T_s)/S \\ &= 0.0538 \times 0.0247\text{ W/m}\cdot\text{K} \times 1.8\text{ m}^2 (15^\circ\text{C} - 0^\circ\text{C})/0.005\text{ m} \\ &= 7.2\text{ W} \end{aligned} \quad (3)$$

Then the weekly cost is

$$\text{Cost} = 7.2\text{ W} \times 0.18 \times 10^{-3}\text{ \$/W}\cdot\text{h} \times 24\text{ h/day} \times 7\text{ days}$$

$$\text{Cost} = \$0.22$$

Continued...

### PROBLEM 9.81 (Cont.)

(b) Solving Equations (1), (2), and (3) for  $1 \text{ mm} \leq S \leq 20 \text{ mm}$ , the following graph can be generated.

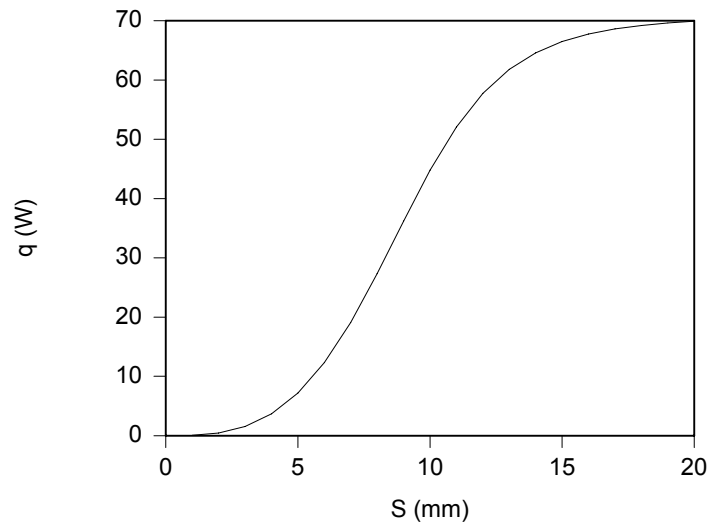

**COMMENTS:** (1) Despite the poor workmanship there is a significant cost savings. (2) With  $Ra_S S/L = 0.65 < 10$  in part (a), we could have used the fully developed results, Equation 9.40. However this equation is not valid for  $Ra_S S \gtrsim 10$ , which corresponds to  $S \gtrsim 10 \text{ mm}$ .

## PROBLEM 9.82

**KNOWN:** Vertical air vent in front door of dishwasher with prescribed width and height. Spacing between isothermal and insulated surface of 20 mm.

**FIND:** (a) Heat loss from the tub surface and (b) Effect on heat rate of changing spacing by  $\pm 10$  mm.

**SCHEMATIC:**

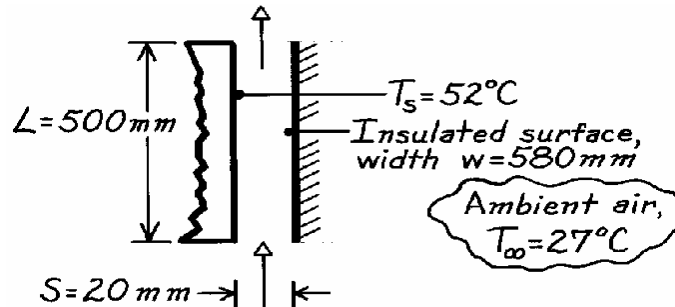

**ASSUMPTIONS:** (1) Steady-state conditions, (2) Vent forms vertical parallel isothermal/adiabatic plates, (3) Ambient air is quiescent.

**PROPERTIES:** Table A-4, ( $T_f = (T_s + T_\infty)/2 = 312.5\text{K}$ , 1 atm):  $\nu = 17.15 \times 10^{-6} \text{ m}^2/\text{s}$ ,  $\alpha = 24.4 \times 10^{-6} \text{ m}^2/\text{s}$ ,  $k = 27.2 \times 10^{-3} \text{ W/m}\cdot\text{K}$ ,  $\beta = 1/T_f$ .

**ANALYSIS:** The vent arrangement forms two vertical plates, one is isothermal,  $T_s$ , and the other is adiabatic ( $q'' = 0$ ). The heat loss can be estimated from Eq. 9.37 with the correlation of Eq. 9.45

using  $C_1 = 144$  and  $C_2 = 2.87$  from Table 9.3:

$$Ra_S = \frac{g\beta(T_s - T_\infty)S^3}{\nu\alpha} = \frac{9.8 \text{ m/s}^2 (1/312.5 \text{ K})(52 - 27) \text{ K} (0.020 \text{ m})^3}{17.15 \times 10^{-6} \text{ m}^2/\text{s} \times 24.4 \times 10^{-6} \text{ m}^2/\text{s}} = 14,988$$

$$q = A_s (T_s - T_\infty) \frac{k}{S} \left[ \frac{C_1}{(Ra_S S/L)^2} + \frac{C_2}{(Ra_S S/L)^{1/2}} \right]^{-1/2} = (0.500 \times 0.580) \text{ m}^2 \times$$

$$(52 - 27) \text{ K} \frac{0.0272 \text{ W/m}\cdot\text{K}}{0.020 \text{ m}} \left[ \frac{C_1}{(Ra_S S/L)^2} + \frac{C_2}{(Ra_S S/L)^{1/2}} \right]^{-1/2} = 28.8 \text{ W.} \quad <$$

(b) To determine the effect of the spacing at  $S = 30$  and  $10$  mm, we need only repeat the above calculations with these results

S (mm)	$Ra_S$	q (W)	
10	1874	26.1	<
30	50,585	28.8	<

Since it would be desirable to minimize heat losses from the tub, based upon these calculations, you would recommend a decrease in the spacing.

**COMMENTS:** For this situation, according to Table 9.3, the spacing corresponding to the maximum heat transfer rate is  $S_{\max} = (S_{\max}/S_{\text{opt}}) \times 2.15(Ra_S/S^3 L)^{-1/4} = 14.5 \text{ mm}$ . Find  $q_{\max} = 28.5 \text{ W}$ . Note that the heat rate is not very sensitive to spacing for these conditions.

### PROBLEM 9.83

**KNOWN:** Dimensions, spacing and temperature of plates in a vertical array. Ambient air temperature. Total width of the array.

**FIND:** Optimal plate spacing for maximum heat transfer from the array and corresponding number of plates and heat transfer.

**SCHEMATIC:**

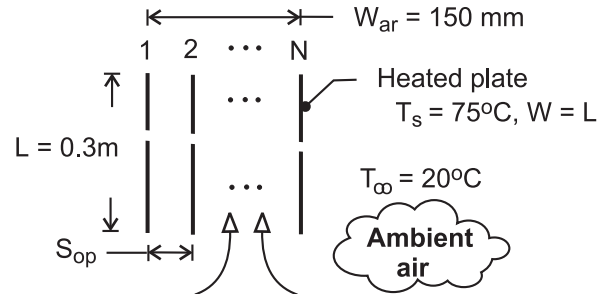

**ASSUMPTIONS:** (1) Steady-state, (2) Negligible plate thickness, (3) Constant properties.

**PROPERTIES:** Table A-4, air ( $p = 1 \text{ atm}$ ,  $\bar{T} = 320 \text{ K}$ ):  $\nu = 17.9 \times 10^{-6} \text{ m}^2/\text{s}$ ,  $k = 0.0278 \text{ W/m}\cdot\text{K}$ ,  $\alpha = 25.5 \times 10^{-6} \text{ m}^2/\text{s}$ ,  $\text{Pr} = 0.704$ ,  $\beta = 0.00313 \text{ K}^{-1}$ .

**ANALYSIS:** With  $\text{Ra}_S/S^3L = g\beta(T_s - T_\infty)/\alpha\nu L = (9.8 \text{ m/s}^2 \times 0.00313 \text{ K}^{-1} \times 55^\circ\text{C}) / (25.5 \times 17.9 \times 10^{-12} \text{ m}^4/\text{s}^2 \times 0.3 \text{ m}) = 1.232 \times 10^{10} \text{ m}^{-4}$ , from Table 9.3, the spacing which maximizes heat transfer for the array is

$$S_{opt} = \frac{2.71}{(\text{Ra}_S/S^3L)^{1/4}} = \frac{2.71}{(1.232 \times 10^{10} \text{ m}^{-4})^{1/4}} = 8.13 \times 10^{-3} \text{ m} = 8.13 \text{ mm} \quad <$$

With the requirement that  $(N - 1) S_{opt} \leq W_{ar}$ , it follows that  $N \leq 1 + 150 \text{ mm}/8.13 \text{ mm} = 19.4$ , in which case

$$N = 19 \quad <$$

The corresponding heat rate is  $q = N(2WL)\bar{h}(T_s - T_\infty)$ , where, from Eq. 9.45 and Table 9.3,

$$\bar{h} = \frac{k}{S} \overline{\text{Nu}}_S = \frac{k}{S} \left[ \frac{576}{(\text{Ra}_S S/L)^2} + \frac{2.87}{(\text{Ra}_S S/L)^{1/2}} \right]^{1/2}$$

With  $\text{Ra}_S S/L = (\text{Ra}_S/S^3L)S^4 = 1.232 \times 10^{10} \text{ m}^{-4} \times (0.00813 \text{ m})^4 = 53.7$ ,

$$\bar{h} = \frac{0.0278 \text{ W/m}\cdot\text{K}}{0.00813 \text{ m}} \left[ \frac{576}{(53.7)^2} + \frac{2.87}{(53.7)^{1/2}} \right] = 3.42(0.200 + 0.392) = 2.02 \text{ W/m}^2 \cdot \text{K}$$

$$q = 19(2 \times 0.3 \text{ m} \times 0.3 \text{ m}) 2.02 \text{ W/m}^2 \cdot \text{K} \times 55^\circ\text{C} = 380 \text{ W} \quad <$$

**COMMENTS:** It would be difficult to fabricate heater plates of thickness  $\delta \ll S_{opt}$ . Hence, subject to the constraint imposed on  $W_{ar}$ ,  $N$  would be reduced, where  $N \leq 1 + W_{ar}/(S_{opt} + \delta)$ .

## PROBLEM 9.84

**KNOWN:** A bank of drying ovens is mounted on a rack in a room with an ambient temperature of 27°C; the cubical ovens are 500 mm to a side and the spacing between the ovens is 15 mm.

**FIND:** (a) Estimate the heat loss from the facing side of an oven when its surface temperature is 47°C, and (b) Explore the effect of the spacing dimension on the heat loss. At what spacing is the heat loss a maximum? Describe the boundary layer behavior for this condition. Can this condition be analyzed by treating the oven side-surface as an isolated vertical plate?

**SCHEMATIC:**

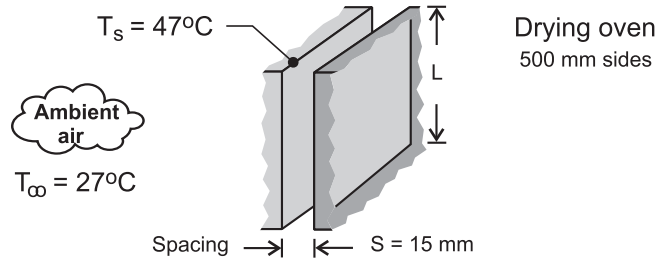

**ASSUMPTIONS:** (1) Steady-state conditions, (2) Adjacent oven sides form a vertical channel with symmetrically heated plates, (3) Room air is quiescent, and channel sides are open to the room air, and (4) Constant properties.

**PROPERTIES:** Table A-4, Air ( $T_f = (T_s + T_\infty)/2 = 310$  K, 1 atm):  $\nu = 1.69 \times 10^{-5}$  m<sup>2</sup>/s,  $k = 0.0270$  W/m·K,  $\alpha = 2.40 \times 10^{-5}$  m<sup>2</sup>/s,  $Pr = 0.706$ ,  $\beta = 1/T_f$ .

**ANALYSIS:** (a) For the isothermal plate channel, Eq. 9.45 with Eqs. 9.37 and 9.38, allow for calculation of the heat transfer from a plate to the ambient air.

$$\overline{Nu}_S = \left[ \frac{C_1}{(Ra_S S/L)^2} + \frac{C_2}{(Ra_S S/L)^{1/2}} \right]^{-1/2} \quad (1)$$

$$\overline{Nu}_S = \frac{q/A}{T_s - T_\infty} \frac{S}{k} \quad (2)$$

$$Ra_S = \frac{g\beta(T_s - T_\infty)S^3}{\alpha\nu} \quad (3)$$

where, from Table 9.3, for the *symmetrical isothermal plates*,  $C_1 = 576$  and  $C_2 = 2.87$ . Properties are evaluated at the film temperature  $T_f$ . Substituting numerical values, evaluate the correlation parameters and the heat rate.

$$Ra_S = \frac{9.8 \text{ m/s}^2 (1/310 \text{ K})(47 - 27) \text{ K} (0.015 \text{ m})^3}{2.40 \times 10^{-5} \text{ m}^2/\text{s} \times 1.69 \times 10^{-5} \text{ m}^2/\text{s}} = 5267$$

$$\overline{Nu}_S = \left[ \frac{576}{(5267 \times 0.015 \text{ m}/0.50 \text{ m})^2} + \frac{2.87}{(5267 \times 0.015 \text{ m}/0.050 \text{ m})^{1/2}} \right]^{-1/2} = 1.994$$

$$1.994 = \frac{q/(0.50 \times 0.50) \text{ m}^2}{(47 - 27) \text{ K}} \frac{0.015 \text{ m}}{0.0270 \text{ W/m} \cdot \text{K}} \quad q = 18.0 \text{ W} \quad <$$

Continued ...

### PROBLEM 9.84 (Cont.)

(b) Using the foregoing relations in *IHT*, the heat rate is calculated for a range of spacing  $S$ .

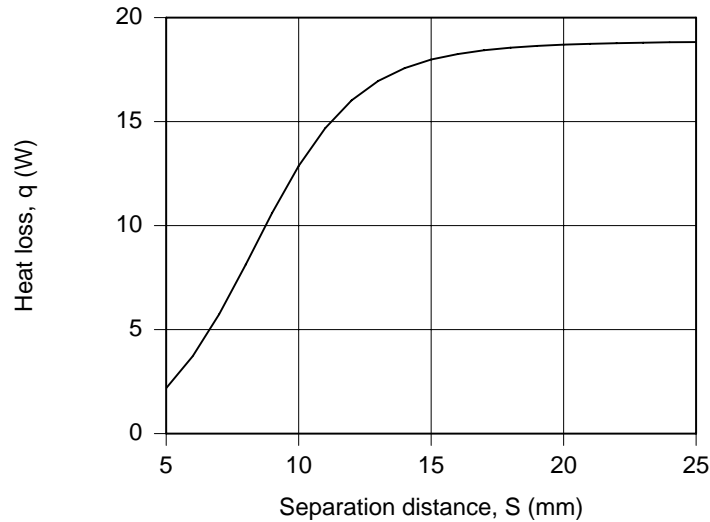

Note that the heat rate increases with increasing spacing up to about  $S = 20$  mm. This implies that for  $S > 20$  mm, the side wall of the oven behaves as an *isolated vertical plate*. From the treatment of the vertical channel, Section 9.7.1, the spacing to provide maximum heat rate from a plate occurs at  $S_{\max}$  which, from Table 9.3, is evaluated by

$$S_{\max} = 1.71 S_{\text{opt}} = 0.01964 \text{ m} = 19.6 \text{ mm}$$

$$S_{\text{opt}} = 2.71 \left( \text{Ra}_S / S^3 L \right)^{-1/4} = 0.01147 \text{ m}$$

For the condition  $S = S_{\max}$ , the spacing is sufficient that the boundary layers on the plates do not overlap.

**COMMENTS:** Using the Churchill-Chu correlation, Eq. 9.26, for the isolated vertical plate, where the characteristic dimension is the height  $L$ , find  $q = 20.2 \text{ W}$  ( $\text{Ra}_L = 1.951 \times 10^8$  and  $\bar{h}_L = 4.03 \text{ W/m}^2 \cdot \text{K}$ ). This value is slightly larger than that from the channel correlation when  $S > S_{\max}$ , but a good approximation.

### PROBLEM 9.85

**KNOWN:** Inclination angle of parallel plate solar collector. Plate spacing. Absorber plate and inlet temperature.

**FIND:** Rate of heat transfer to collector fluid.

**SCHEMATIC:**

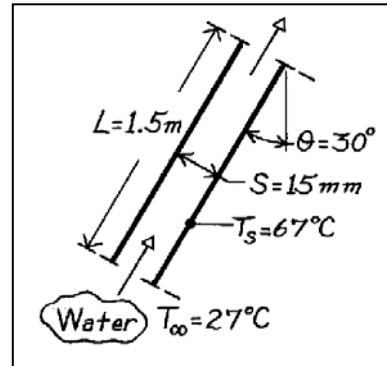

**ASSUMPTIONS:** (1) Flow in collector corresponds to buoyancy driven flow between parallel plates with quiescent fluids at the inlet and outlet, (2) Constant properties.

**PROPERTIES:** Table A-6, Water ( $\bar{T} = 320\text{K}$ ):  $\rho = 989\text{ kg/m}^3$ ,  $c_p = 4180\text{ J/kg}\cdot\text{K}$ ,  $\mu = 577 \times 10^{-6}\text{ kg/s}\cdot\text{m}$ ,  $k = 0.640\text{ W/m}\cdot\text{K}$ ,  $\beta = 436.7 \times 10^{-6}\text{ K}^{-1}$ .

**ANALYSIS:** With

$$\alpha = \frac{k}{\rho c_p} = \frac{0.640\text{ W/m}\cdot\text{K}}{989\text{ kg/m}^3 (4180\text{ J/kg}\cdot\text{K})} = 1.55 \times 10^{-7}\text{ m}^2/\text{s}$$

$$\nu = (\mu / \rho) = (577 \times 10^{-6}\text{ kg/s}\cdot\text{m}) / 989\text{ kg/m}^3 = 5.83 \times 10^{-7}\text{ m}^2/\text{s}$$

find

$$\text{Ra}_S \frac{S}{L} = \frac{g\beta(T_s - T_\infty)S^4}{\alpha\nu L} = \frac{9.8\text{ m/s}^2 (436.7 \times 10^{-6}\text{ K}^{-1})(40\text{ K})(0.015\text{ m})^4}{(1.55 \times 10^{-7}\text{ m}^2/\text{s})(5.83 \times 10^{-7}\text{ m}^2/\text{s})1.5\text{ m}}$$

$$\text{Ra}_S \frac{S}{L} = 6.39 \times 10^4.$$

Since  $\text{Ra}_S(S/L) > 200$ , Eq. 9.47 may be used,

$$\overline{\text{Nu}}_S = 0.645 [\text{Ra}_S(S/L)]^{1/4} = 0.645 (6.39 \times 10^4)^{1/4} = 10.3$$

$$\bar{h} = \overline{\text{Nu}}_S \frac{k}{S} = 10.3 (0.64\text{ W/m}\cdot\text{K} / 0.015\text{ m}) = 438\text{ W/m}^2\cdot\text{K}.$$

Hence the heat rate is

$$q = \bar{h}A(T_s - T_\infty) = 438\text{ W/m}^2\cdot\text{K} (1.5\text{ m})(67 - 27)\text{ K} = 26,300\text{ W/m}.$$

<

**COMMENTS:** Such a large heat rate would necessitate use of a concentrating solar collector for which the normal solar flux would be significantly amplified.

## PROBLEM 9.86

**KNOWN:** Critical Rayleigh number for onset of convection in vertical cavity filled with atmospheric air. Temperatures of opposing surfaces.

**FIND:** Maximum allowable spacing for heat transfer by conduction across the air. Effect of surface temperature and air pressure.

**SCHEMATIC:**

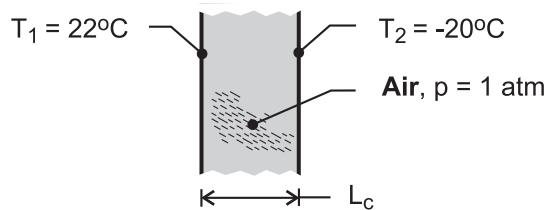

**ASSUMPTIONS:** (1) Critical Rayleigh number is  $Ra_{L,c} = 2000$ , (2) Constant properties.

**PROPERTIES:** Table A-4, air [ $T = (T_1 + T_2)/2 = 1^\circ\text{C} = 274\text{K}$ ]:  $\nu = 13.6 \times 10^{-6} \text{ m}^2/\text{s}$ ,  $k = 0.0242 \text{ W/m}\cdot\text{K}$ ,  $\alpha = 19.1 \times 10^{-6} \text{ m}^2/\text{s}$ ,  $\beta = 0.00365 \text{ K}^{-1}$ .

**ANALYSIS:** With  $Ra_{L,c} = g \beta (T_1 - T_2) L_c^3 / \alpha \nu$ ,

$$L_c = \left[ \frac{\alpha \nu Ra_{L,c}}{g \beta (T_1 - T_2)} \right]^{1/3} = \left[ \frac{19.1 \times 13.6 \times 10^{-12} \text{ m}^4 / \text{s}^2 \times 2000}{9.8 \text{ m/s}^2 \times 0.00365 \text{ K}^{-1} \times 42^\circ\text{C}} \right]^{1/3} = 0.007 \text{ m} = 7 \text{ mm} \quad <$$

The critical value of the spacing, and hence the corresponding thermal resistance of the air space, increases with a decreasing temperature difference,  $T_1 - T_2$ , and decreasing air pressure. With  $\nu = \mu/\rho$  and  $\alpha \equiv k/\rho c_p$ , both quantities increase with decreasing  $p$ , since  $\rho$  decreases while  $\mu$ ,  $k$  and  $c_p$  are approximately unchanged.

**COMMENTS:** (1) For the prescribed conditions and  $L_c = 7 \text{ mm}$ , the conduction heat flux across the air space is  $q'' = k (T_1 - T_2) / L_c = 0.0242 \text{ W/m}\cdot\text{K} \times 42^\circ\text{C} / 0.007 \text{ m} = 145 \text{ W/m}^2$ , (2) With triple pane construction, the conduction heat loss could be reduced by a factor of approximately two, (3) Heat loss is also associated with radiation exchange between the panes.



### PROBLEM 9.87

**KNOWN:** Temperatures and dimensions of a window-storm window combination.

**FIND:** Rate of heat loss by free convection.

**SCHEMATIC:**

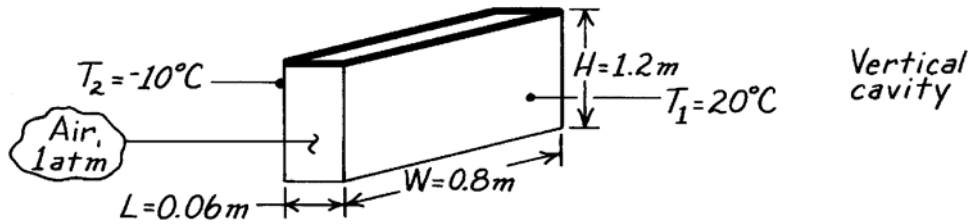

**ASSUMPTIONS:** (1) Both glass plates are of uniform temperature with insulated interconnecting walls and (2) Negligible radiation exchange.

**PROPERTIES:** Table A-4, Air (278K, 1 atm):  $\nu = 13.93 \times 10^{-6} \text{ m}^2/\text{s}$ ,  $k = 0.0245 \text{ W/m}\cdot\text{K}$ ,  $\alpha = 19.6 \times 10^{-6} \text{ m}^2/\text{s}$ ,  $\text{Pr} = 0.71$ ,  $\beta = 0.00360 \text{ K}^{-1}$ .

**ANALYSIS:** For the vertical cavity,

$$\text{Ra}_L = \frac{g\beta(T_1 - T_2)L^3}{\alpha\nu} = \frac{9.8 \text{ m/s}^2 (0.00360 \text{ K}^{-1})(30^\circ\text{C})(0.06\text{m})^3}{19.6 \times 10^{-6} \text{ m}^2/\text{s} \times 13.93 \times 10^{-6} \text{ m}^2/\text{s}}$$

$$\text{Ra}_L = 8.37 \times 10^5.$$

With  $(H/L) = 20$ , Eq. 9.52 may be used as a first approximation for  $\text{Pr} = 0.71$ ,

$$\overline{\text{Nu}}_L = 0.42 \text{Ra}_L^{1/4} \text{Pr}^{0.012} (H/L)^{-0.3} = 0.42 (8.37 \times 10^5)^{1/4} (0.71)^{0.012} (20)^{-0.3}$$

$$\overline{\text{Nu}}_L = 5.2$$

$$\bar{h} = \overline{\text{Nu}}_L \frac{k}{L} = 5.2 \frac{0.0245 \text{ W/m}\cdot\text{K}}{0.06\text{m}} = 2.1 \text{ W/m}^2 \cdot \text{K}.$$

The heat loss by free convection is then

$$q = \bar{h} A (T_1 - T_2)$$

$$q = 2.1 \text{ W/m}^2 \cdot \text{K} (1.2\text{m} \times 0.8\text{m}) (30^\circ\text{C}) = 61 \text{ W}.$$

<

**COMMENTS:** In such an application, radiation losses should also be considered, and infiltration effects could render heat loss by free convection significant.

## PROBLEM 9.88

**KNOWN:** Dimensions of horizontal rectangular duct and radiation shield. Temperatures of duct and shield walls.

**FIND:** Convection heat loss per unit length.

**SCHEMATIC:**

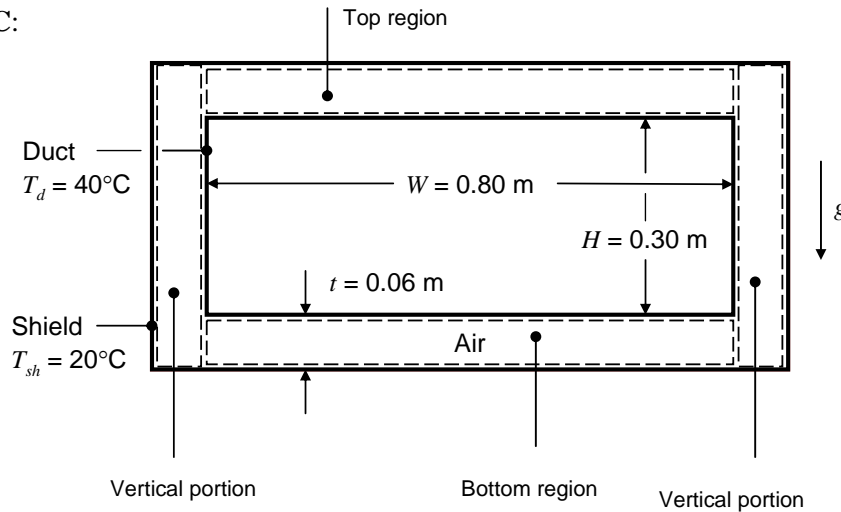

**ASSUMPTIONS:** (1) Steady-state, (2) Uniform duct and shield wall temperatures, (3) Constant properties, (4) Convection occurs in four distinct rectangular regions, (4) Convection is two-dimensional.

**PROPERTIES:** Table A-4, Air ( $T = 303 \text{ K}$ ):  $\nu = 16.19 \times 10^{-6} \text{ m}^2/\text{s}$ ,  $\alpha = 22.94 \times 10^{-6} \text{ m}^2/\text{s}$ ,  $k = 26.5 \times 10^{-3} \text{ W/m} \cdot \text{K}$ ,  $Pr = 0.707$ ,  $\beta = 1/T = 0.0033 \text{ K}^{-1}$ .

**ANALYSIS:** Within the vertical portions of the enclosure, motion will occur in the vertical direction and will likely extend from the bottom to the top of the shield wall. Thus, the aspect ratio for the vertical regions is  $(H + 2t)/t = 0.42/0.06 = 7$ . The Rayleigh number based on the enclosure width,  $t$ , is

$$Ra_t = \frac{g\beta(T_1 - T_2)t^3}{\nu\alpha} = \frac{9.8 \text{ m/s}^2 \times 0.0033 \text{ K}^{-1} \times (40 - 20)^\circ\text{C} \times (0.06 \text{ m})^3}{16.19 \times 10^{-6} \text{ m}^2/\text{s} \times 22.94 \times 10^{-6} \text{ m}^2/\text{s}} = 3.76 \times 10^5$$

Therefore, Eq. 9.50 holds, and yields

$$\overline{Nu}_t = 0.22 \left( \frac{Pr}{0.2 + Pr} Ra_t \right)^{0.28} \left( \frac{H + 2t}{t} \right)^{-1/4} = 0.22 \left( \frac{0.707}{0.2 + 0.707} 3.76 \times 10^5 \right)^{0.28} (7)^{-1/4} = 4.59$$

and

$$\overline{h}_{\text{vert}} = \overline{Nu}_t k / t = 4.59 \times 26.5 \times 10^{-3} \text{ W/m} \cdot \text{K} / 0.06 \text{ m} = 2.03 \text{ W/m}^2 \cdot \text{K}$$

The two horizontal regions differ from one another. The bottom region is heated from above. There is therefore no air motion and  $\overline{Nu}_t = 1$ , which yields

$$\overline{h}_{\text{bot}} = \overline{Nu}_{t,\text{bot}} k / t = 1 \times 26.5 \times 10^{-3} \text{ W/m} \cdot \text{K} / 0.06 \text{ m} = 0.442 \text{ W/m}^2 \cdot \text{K}$$

The top region is heated from below and the Rayleigh number exceeds the critical value for convection to occur,  $Ra_{t,\text{crit}} = 1708$ . From Eq. 9.49,

Continued...

**PROBLEM 9.88 (Cont.)**

$$\overline{Nu}_{t,\text{top}} = 0.069 Ra_t^{1/3} Pr^{0.074} = 4.85$$

and

$$\overline{h}_{\text{top}} = \overline{Nu}_{t,\text{top}} k / t = 4.85 \times 26.5 \times 10^{-3} \text{ W/m} \cdot \text{K} / 0.06 \text{ m} = 2.15 \text{ W/m}^2 \cdot \text{K}$$

Finally, the convection heat loss per unit length is

$$\begin{aligned} q'_{\text{conv}} &= \left[ 2\overline{h}_{\text{vert}} (H + 2t) + (\overline{h}_{\text{bot}} + \overline{h}_{\text{top}}) W \right] (T_1 - T_2) \\ &= \left[ 2 \times 2.03 \text{ W/m}^2 \cdot \text{K} (0.42 \text{ m}) + (0.442 + 2.15) \text{ W/m}^2 \cdot \text{K} \times 0.8 \text{ m} \right] (40 - 20)^\circ\text{C} = 75.5 \text{ W/m} \quad < \end{aligned}$$

**COMMENTS:** (1) The identified rectangular regions do not satisfy the adiabatic end condition. (2) Presumably the shield would have a small emissivity to reduce radiation. However, if both surfaces have an emissivity of one, radiation across the enclosure is given by  $q'_{\text{rad}} = \sigma [2W + 2H] (T_1^4 - T_2^4)$   
 $= 5.67 \times 10^{-8} \text{ W/m}^2 \cdot \text{K}^4 \times [2 \times 0.8 \text{ m} + 2 \times 0.3 \text{ m}] \times (313^4 - 293^4) \text{ K}^4 = 278 \text{ W/m}$ . Radiation can be more significant than free convection.

### PROBLEM 9.89

**KNOWN:** Absorber plate and cover plate temperatures and geometry for a flat plate solar collector.

**FIND:** Heat flux due to free convection.

**SCHEMATIC:**

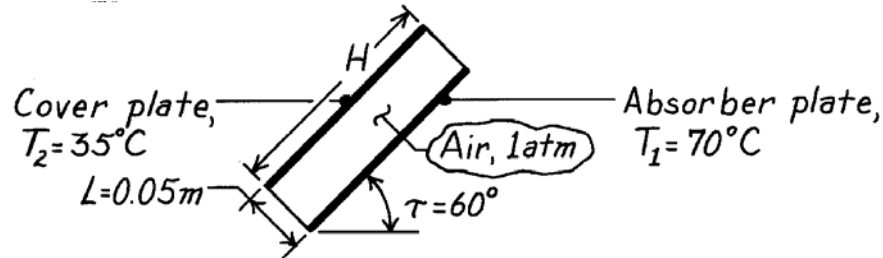

**ASSUMPTIONS:** (1) Aspect ratio,  $H/L$ , is greater than 12.

**PROPERTIES:** Table A-4, Air (325K, 1 atm):  $\nu = 18.4 \times 10^{-6} \text{ m}^2/\text{s}$ ,  $k = 0.028 \text{ W/m}\cdot\text{K}$ ,  $\alpha = 26.2 \times 10^{-6} \text{ m}^2/\text{s}$ ,  $\text{Pr} = 0.703$ ,  $\beta = 3.08 \times 10^{-3} \text{ K}^{-1}$ .

**ANALYSIS:** For the inclined enclosure,

$$\text{Ra}_L = \frac{g \beta (T_1 - T_2) L^3}{\alpha \nu} = \frac{9.8 \text{ m/s}^2 (3.08 \times 10^{-3} \text{ K}^{-1}) (70 - 35)^\circ\text{C} (0.05 \text{ m})^3}{(26.2 \times 10^{-6} \text{ m}^2/\text{s}) (18.4 \times 10^{-6} \text{ m}^2/\text{s})}$$

$$\text{Ra}_L = 2.74 \times 10^5.$$

With  $\tau < \tau^* = 70^\circ$ , Table 9.4,

$$\overline{\text{Nu}}_L = 1 + 1.44 \left[ 1 - \frac{1708}{\text{Ra}_L \cos \tau} \right]^{\bullet} \left[ 1 - \frac{1708 (\sin 1.8\tau)^{1.6}}{\text{Ra}_L \cos \tau} \right] + \left[ \left( \frac{\text{Ra}_L \cos \tau}{5830} \right)^{1/3} - 1 \right]^{\bullet}$$

$$\overline{\text{Nu}}_L = 1 + 1.44(0.99)(0.99) + 1.86 = 4.28$$

$$\bar{h} = \overline{\text{Nu}}_L \frac{k}{L} = 4.28 \frac{0.028 \text{ W/m}\cdot\text{K}}{0.05 \text{ m}} = 2.4 \text{ W/m}^2 \cdot \text{K}.$$

Hence, the heat flux is

$$q'' = h(T_1 - T_2) = 2.4 \text{ W/m}^2 \cdot \text{K} (70 - 35)^\circ\text{C}$$

$$q'' = 84 \text{ W/m}^2.$$

<

**COMMENTS:** Radiation exchange between the absorber and cover plates will also contribute to heat loss from the collector.

### PROBLEM 9.90

**KNOWN:** Dimensions and properties of paraffin slab, initial liquid layer thickness. Temperature of the hot surface.

**FIND:** (a) Amount of paraffin melted over a period of 5 hours in response to bottom heating, (b) Amount of energy used to melt the paraffin and amount of energy needed to raise the average temperature of the liquid paraffin, (c) Amount of paraffin melted over a period of 5 hours with top heating.

**SCHEMATIC:**

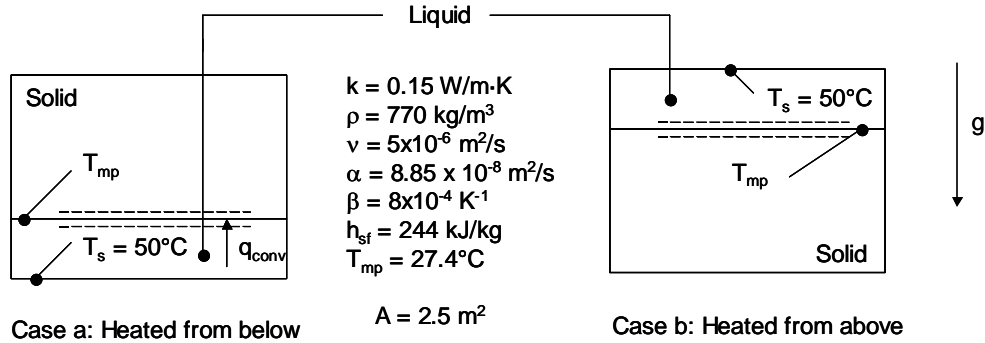

**ASSUMPTIONS:** (1) Constant properties, (2) Neglect change of sensible energy of the liquid, (3) One-dimensional heat transfer.

**PROPERTIES:** Given, see schematic.

**ANALYSIS:** (a) Neglecting the change in the sensible energy, the mass melted is

$$M = E/h_{sf} = q'' At/h_{sf} = \bar{h}A(T_s - T_{mp})t/h_{sf}$$

Using the Globe and Dropkin correlation,

$$h = 0.069k \left[ \frac{g\beta(T_s - T_{mp})}{\nu\alpha} \right]^{1/3} \text{Pr}^{0.074}$$

Combining the equations gives

$$M = 0.15 \text{ W/m}\cdot\text{K} \times 0.069 \times \left[ \frac{9.8 \text{ m/s}^2 \times 8 \times 10^{-4} \text{ K}^{-1} \times (50 - 27.4)^\circ\text{C}}{5 \times 10^{-6} \text{ m}^2/\text{s} \times 8.85 \times 10^{-8} \text{ m}^2/\text{s}} \right]^{1/3} \times \left[ \frac{5 \times 10^{-6} \text{ m}^2/\text{s}}{8.85 \times 10^{-8} \text{ m}^2/\text{s}} \right]^{0.074}$$

$$\times \frac{2.5 \text{ m}^2 \times (50 - 27.4)^\circ\text{C} \times 5 \text{ h} \times 3600 \text{ s/h}}{244 \times 10^3 \text{ J/kg}}$$

$$= 429 \text{ kg} \quad <$$

(b) The energy consumed to melt the paraffin is

Continued...

**PROBLEM 9.90 (Cont.)**

$$E_m = Mh_{sf} = 429\text{kg} \times 244 \times 10^3 \text{J/kg} = 105 \times 10^6 \text{J} \quad <$$

The energy associated with raising the temperature to  $\bar{T} = (50^\circ\text{C} + 27.4^\circ\text{C})/2 = 38.7^\circ\text{C}$  is

$$\begin{aligned} E_s &= Mc_p(\bar{T} - T_{mp}) = M(k/\rho\alpha)(\bar{T} - T_{mp}) \\ &= 429\text{kg} \times \left( \frac{0.15\text{W/m}\cdot\text{K}}{770\text{kg/m}^3 \cdot 8.85 \times 10^{-8} \text{m}^2/\text{s}} \right) \times (38.7 - 27.4^\circ\text{C}) = 10.7 \times 10^6 \text{J} \end{aligned}$$

The ratio of the change of sensible energy to energy absorbed in the phase change is

$$E_s/E_m = 10.7 \times 10^6 \text{J} / 105 \times 10^6 \text{J} = 0.102 \quad <$$

(c) The liquid layer is heated from above. Heat transfer in the liquid phase is by conduction. The temperature distribution in the liquid is linear if the change in sensible energy of the liquid is neglected. Hence, an energy balance on the control surface shown in the schematic yields

$$q'' = k \frac{(T_s - T_{mp})}{s} = \rho h_{sf} \frac{ds}{dt}$$

Separating variables and integrating

$$\frac{k(T_s - T_{mp})}{\rho h_{sf}} \int_{t=0}^t dt = \int_{s_i}^{s(t)} s ds \quad \text{or} \quad s(t) = \sqrt{\frac{2k(T_s - T_{mp})t}{\rho h_{sf}} + s_i^2}$$

Therefore,

$$s(t = 5\text{h}) = \sqrt{\frac{2 \times 0.15\text{W/m}\cdot\text{K} \times (50 - 27.4)^\circ\text{C} \times 5\text{h} \times 3600\text{s/h}}{770\text{kg/m}^3 \times 244 \times 10^3 \text{J/kg}} + (0.01\text{m})^2}$$

$$= 27 \times 10^{-3} \text{m} = 27 \text{mm}$$

$$M = A\rho[s(t = 5\text{h}) - s_i] = 2.5\text{m}^2 \times 770\text{kg/m}^3 \times (27 \times 10^{-3}\text{m} - 10 \times 10^{-3}\text{m}) = 33.4\text{kg} \quad <$$

**COMMENTS:** (1) For the bottom heated case at  $t = 5$  h, the solid-liquid interface is located at  $M/\rho A + s_i = 429 \text{kg}/(770 \text{kg/m}^3 \times 2.5 \text{m}^2) + 0.01 \text{m} = 0.233 \text{m}$ . The Rayleigh numbers associated with the bottom heating case range from  $Ra_s = g\beta(T_s - T_{mp})s_i^3/\nu\alpha = 9.8\text{m/s}^2 \times 8 \times 10^{-4} \text{K}^{-1} \times (50 - 27.4)^\circ\text{C} \times (0.01\text{m})^3 / (5 \times 10^{-6} \text{m}^2/\text{s} \times 8.85 \times 10^{-8} \text{m}^2/\text{s}) = 4 \times 10^5$  to  $5 \times 10^9$  at  $t = 5$  h. Hence, use of the Globe and Dropkin correlation is justified. (2) The ratio of the change in sensible energy to the absorption of latent energy is referred to as the liquid phase Stefan number. Since the liquid phase Stefan number is much less than unity, it is reasonable to neglect the change of sensible energy of the liquid phase when calculating the melting rate or solid-liquid interface location.

### PROBLEM 9.91

**KNOWN:** Rectangular cavity of two parallel, 0.5m square plates with insulated inter-connecting sides and with prescribed separation distance and surface temperatures.

**FIND:** Heat flux between surfaces for three orientations of the cavity: (a) Vertical  $\tau = 90^\circ$ , (b) Horizontal with  $\tau = 0^\circ$ , and (c) Horizontal with  $\tau = 180^\circ$ .

**SCHEMATIC:**

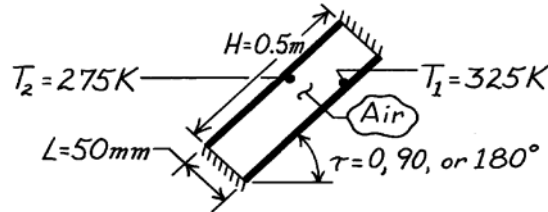

**ASSUMPTIONS:** (1) Radiation exchange is negligible, (2) Air is at atmospheric pressure.

**PROPERTIES:** Table A-4, Air ( $T_f = (T_1 + T_2)/2 = 300\text{K}$ , 1 atm):  $\nu = 15.89 \times 10^{-6} \text{ m}^2/\text{s}$ ,  $k = 0.0263 \text{ W/m}\cdot\text{K}$ ,  $\alpha = 22.5 \times 10^{-6} \text{ m}^2/\text{s}$ ,  $\text{Pr} = 0.707$ ,  $\beta = 1/T_f = 3.333 \times 10^{-3} \text{ K}^{-1}$ .

**ANALYSIS:** The convective heat flux between the two cavity plates is

$$q''_{\text{conv}} = \bar{h}(T_1 - T_2)$$

where  $\bar{h}$  is estimated from the appropriate enclosure correlation which will depend upon the Rayleigh number. From Eq. 9.25, find

$$\text{Ra}_L = \frac{g\beta(T_1 - T_2)L^3}{\nu\alpha} = \frac{9.8 \text{ m/s}^2 \times 3.333 \times 10^{-3} \text{ K}^{-1} (325 - 275) \text{ K} (0.05 \text{ m})^3}{15.89 \times 10^{-6} \text{ m}^2/\text{s} \times 22.5 \times 10^{-6} \text{ m}^2/\text{s}} = 5.710 \times 10^5.$$

Note that  $H/L = 0.5/0.05 = 10$ , a factor which is important in selecting correlations.

(a) With  $\tau = 90^\circ$ , for a vertical cavity, Eq. 9.50, is appropriate,

$$\overline{\text{Nu}}_L = 0.22 \left( \frac{\text{Pr}}{0.2 + \text{Pr}} \text{Ra}_L \right)^{0.28} \left( \frac{H}{L} \right)^{-1/4} = 0.22 \left( \frac{0.707}{0.2 + 0.707} \times 5.71 \times 10^5 \right)^{0.28} (10)^{-1/4} = 4.72$$

$$\bar{h}_L = \frac{k}{L} \overline{\text{Nu}}_L = \frac{0.0263 \text{ W/m}\cdot\text{K}}{0.05 \text{ m}} \times 4.72 = 2.48 \text{ W/m}^2 \cdot \text{K}$$

$$q''_{\text{conv}} = 2.48 \text{ W/m}^2 \cdot \text{K} (325 - 275) \text{ K} = 124 \text{ W/m}^2. \quad <$$

(b) With  $\tau = 0^\circ$  for a horizontal cavity heated from below, Eq. 9.49 is appropriate.

$$\bar{h} = \frac{k}{L} \overline{\text{Nu}}_L = 0.069 \frac{k}{L} \text{Ra}_L^{1/3} \text{Pr}^{0.074} = 0.069 \frac{0.0263 \text{ W/m}\cdot\text{K}}{0.05 \text{ m}} (5.710 \times 10^5)^{1/3} (0.707)^{0.074}$$

$$\bar{h} = 2.92 \text{ W/m}^2 \cdot \text{K}$$

$$q''_{\text{conv}} = 2.92 \text{ W/m}^2 \cdot \text{K} (325 - 275) \text{ K} = 146 \text{ W/m}^2. \quad <$$

(c) For  $\tau = 180^\circ$  corresponding to the horizontal orientation with the heated plate on the top, heat transfer will be by conduction. That is,

$$\overline{\text{Nu}}_L = 1 \quad \text{or} \quad \bar{h}_L = \overline{\text{Nu}}_L \cdot \frac{k}{L} = 1 \times 0.0263 \text{ W/m}\cdot\text{K} / (0.05 \text{ m}) = 0.526 \text{ W/m}^2 \cdot \text{K}.$$

$$q''_{\text{conv}} = 0.526 \text{ W/m}^2 \cdot \text{K} (325 - 275) \text{ K} = 26.3 \text{ W/m}^2. \quad <$$

**COMMENTS:** Compare the heat fluxes for the various orientations and explain physically their relative magnitudes.

## PROBLEM 9.92

**KNOWN:** Horizontal flat roof and vertical wall sections of same dimensions exposed to identical temperature differences.

**FIND:** (a) Ratio of convection heat rate for horizontal section to that of the vertical section and (b) Effect of inserting a baffle at the mid-height of the vertical wall section on the convection heat rate.

**SCHEMATIC:**

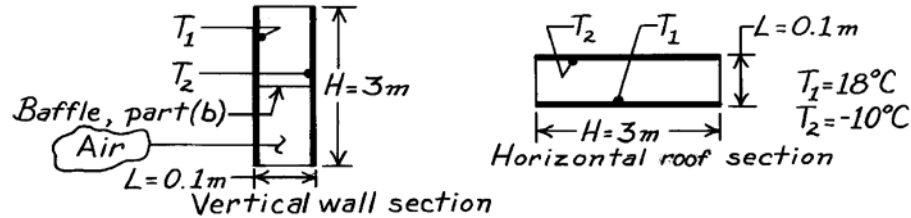

**ASSUMPTIONS:** (1) Ends of sections and baffle adiabatic, (2) Steady-state conditions.

**PROPERTIES:** Table A-4, Air ( $\bar{T} = (T_1 + T_2)/2 = 277\text{K}$ , 1 atm):  $\nu = 13.84 \times 10^{-6} \text{ m}^2/\text{s}$ ,  $k = 0.0245 \text{ W/m}\cdot\text{K}$ ,  $\alpha = 19.5 \times 10^{-6} \text{ m}^2/\text{s}$ ,  $\text{Pr} = 0.713$ .

**ANALYSIS:** (a) The ratio of the convection heat rates is

$$\frac{q_{\text{hor}}}{q_{\text{vert}}} = \frac{\bar{h}_{\text{hor}} A_s \Delta T}{\bar{h}_{\text{vert}} A_s \Delta T} = \frac{\bar{h}_{\text{hor}}}{\bar{h}_{\text{vert}}} \quad (1)$$

To estimate coefficients, recognizing both sections have the same characteristic length,  $L = 0.1 \text{ m}$ , with  $\text{Ra}_L = g\beta\Delta T L^3 / \nu\alpha$  find

$$\text{Ra}_L = \frac{9.8 \text{ m/s}^2 \times (1/277\text{K})(18 - (-10))\text{K}(0.1\text{m})^3}{13.84 \times 10^{-6} \text{ m}^2/\text{s} \times 19.5 \times 10^{-6} \text{ m}^2/\text{s}} = 3.67 \times 10^6$$

The appropriate correlations for the sections are Eqs. 9.49 and 9.52 (with  $H/L = 30$ ),

$$\overline{\text{Nu}}_L \Big|_{\text{hor}} = 0.069 \text{Ra}_L^{1/3} \text{Pr}^{0.074} \quad \overline{\text{Nu}}_L \Big|_{\text{vert}} = 0.42 \text{Ra}_L^{1/4} \text{Pr}^{0.012} (H/L)^{-0.3} \quad (3,4)$$

Using Eqs. (3) and (4), the ratio of Eq. (1) becomes,

$$\frac{q_{\text{hor}}}{q_{\text{vert}}} = \frac{0.069 \text{Ra}_L^{1/3} \text{Pr}^{0.074}}{0.42 \text{Ra}_L^{1/4} \text{Pr}^{0.012} (H/L)^{-0.3}} = \frac{0.069 (3.67 \times 10^6)^{1/3} (0.713)^{0.074}}{0.42 (3.67 \times 10^6)^{1/4} (0.713)^{0.012} (30)^{-0.3}} = 1.57. \quad <$$

(b) The effect of the baffle in the vertical wall section is to reduce  $H/L$  from 30 to 15. Using Eq. 9.52, it follows,

$$\frac{q_{\text{baf}}}{q} = \frac{\bar{h}_{\text{baf}}}{\bar{h}} = \frac{(H/L)_{\text{baf}}^{-0.3}}{(H/L)^{-0.3}} = \left(\frac{15}{30}\right)^{-0.3} = 1.23. \quad <$$

That is, the effect of the baffle is to increase the convection heat rate.

**COMMENTS:** (1) Note that the heat rate for the horizontal section is 57% larger than that for the vertical section for the same  $(T_1 - T_2)$ . This indicates the importance of heat losses from the ceiling or roofs in house construction. (2) Recognize that for Eq. 9.52, the  $\text{Pr} > 1$  requirement is not completely satisfied. (3) What is the physical explanation for the result of part (b)?



### PROBLEM 9.93

**KNOWN:** Dimensions of horizontal air space separating plates of known temperature.

**FIND:** (a) Convective heat flux for a 50 mm gap, hot and cold plate temperatures of  $T_h = 200^\circ\text{C}$  and  $T_c = 50^\circ\text{C}$ , respectively, (b) Minimum number of thin aluminum sheets needed to suppress convection, (c) Conduction heat flux with the sheets in place.

**SCHEMATIC:**

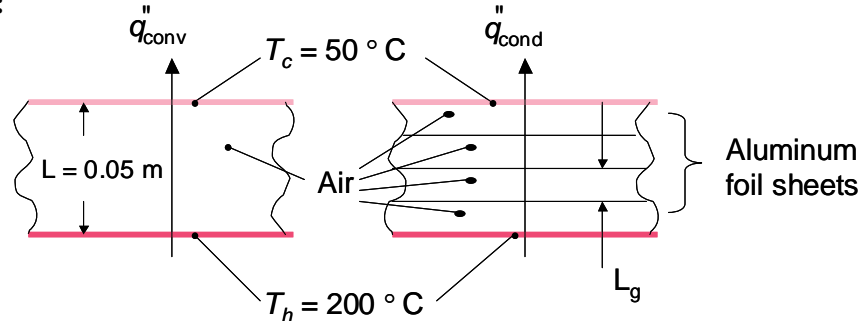

**ASSUMPTIONS:** (1) Constant properties, (2) Steady-state conditions, (3) Foil sheets have negligible conduction resistance and negligible thickness.

**PROPERTIES:** Table A.4, air: ( $T_f = (200^\circ\text{C} + 50^\circ\text{C})/2 = 125^\circ\text{C}$ ):  $k = 0.03365 \text{ W/m}\cdot\text{K}$ ,  $\nu = 2.619 \times 10^{-5} \text{ m}^2/\text{s}$ ,  $\alpha = 3.796 \times 10^{-5} \text{ m}^2/\text{s}$ ,  $\text{Pr} = 0.6904$ .

**ANALYSIS:** (a) The Rayleigh number is

$$\begin{aligned} \text{Ra} &= g\beta(T_h - T_c)L^3 / \nu \cdot \alpha \\ &= 9.8 \text{ m/s}^2 \times \frac{1}{(125 + 273) \text{ K}} \times (200 - 50)^\circ\text{C} \times (0.05 \text{ m})^3 / (2.619 \times 10^{-5} \text{ m}^2/\text{s} \times 3.796 \times 10^{-5} \text{ m}^2/\text{s}) \\ &= 4.64 \times 10^5 \end{aligned}$$

Using the Globe and Dropkin correlation,

$$\begin{aligned} \bar{h}_L &= 0.069(k/L)\text{Ra}^{1/3} \text{Pr}^{0.074} = 0.069 \times (0.03365 \text{ W/m}\cdot\text{K} / 5 \times 10^{-3} \text{ m}) \times (4.64 \times 10^5)^{1/3} \times (0.6904)^{0.074} \\ &= 3.50 \text{ W/m}^2\cdot\text{K} \end{aligned}$$

Therefore,  $q_{\text{conv}}'' = 3.50 \text{ W/m}^2 \cdot \text{K} \times (200 - 50)^\circ\text{C} = 525 \text{ W/m}^2$  <

(b) For  $\text{Ra}_{L_g} < 1708$ , there will be no convection in an air layer. The number of gaps is  $N_g = N + 1$ . The gap width is  $L_g = L/(N + 1)$  and, as a first estimate, the temperature difference across each gap is  $\Delta T_g = (T_h - T_c)/(N + 1)$ . We require  $1708 > \text{Ra}_{L_g}$ , or

Continued...

**PROBLEM 9.93 (Cont.)**

$$\frac{g\beta[(T_h - T_c)(N + 1)][L/(N + 1)]^3}{\nu \cdot \alpha} < 1708$$

or

$$\frac{9.8\text{m/s}^2 \times [1/(273 + 125)]\text{K}^{-1} \times [(200 - 50)^\circ\text{C}/(N + 1)] \times [0.05\text{m}/(N + 1)]^3}{2.619 \times 10^{-5}\text{m}^2/\text{s} \times 3.796 \times 10^{-5}\text{m}^2/\text{s}} < 1708$$

from which we may determine  $N > 3.06$ . Therefore, we specify  $N = 4$ . <

(c) Neglecting the thickness and thermal resistance of the foil sheets,

$$q''_{\text{cond}} = k(T_h - T_c)/L = 0.03365\text{W/m} \cdot \text{K} \times (200 - 50)^\circ\text{C}/0.05\text{m} = 101\text{W/m}^2 \quad <$$

**COMMENTS:** (1) Installation of the foils results in a  $100 - 101/525 = 81\%$  reduction in heat transfer across the large gap. (2) Because of the temperature dependence of the thermophysical properties, we should check to make sure the Rayleigh numbers associated with the top and bottom gaps do not exceed 1708. Assuming  $\Delta T_g = (T_h - T_c)/(N + 1) = 150^\circ\text{C}/(5) = 30^\circ\text{C}$  and evaluating properties at the average gap temperatures of  $65^\circ\text{C}$  and  $185^\circ\text{C}$ , respectively, we find  $Ra_{L,g} = 1569$  for the top gap and 394 for the bottom gap. We therefore conclude that convection is in fact suppressed in all the gaps. (3) A more accurate handling of the thermophysical property variation would account for the temperature variation of the thermal conductivity in each gap and, in turn, the variation in the temperatures of the individual foil sheets. Equating the conduction heat transfer through each gap and evaluating the thermal conductivity for each gap at the average air temperature in the gap, one finds (using an iterative procedure or IHT) foil temperatures of (top to bottom):  $T_1 = 84.3^\circ\text{C}$ ,  $T_2 = 116.1^\circ\text{C}$ ,  $T_3 = 145.7^\circ\text{C}$  and  $T_4 = 173.6^\circ\text{C}$ . Values of  $Ra_{L,g}$  are 1742 and 340 for the top and bottom gaps, respectively. Hence, with 4 foils, the top gap will experience very weak convection and a conservative specification would call for installation of  $N = 5$  foils. (4) As will become evident in Chapter 13, the foils will also reduce radiation heat transfer across the gap.

### PROBLEM 9.94

**KNOWN:** Double-glazed window of variable spacing  $L$  between panes filled with either air or carbon dioxide.

**FIND:** Heat transfer across window for variable spacing when filled with either gas. Consider these conditions (outside,  $T_1$ ; inside,  $T_2$ ): winter ( $-10, 20^\circ\text{C}$ ) and summer ( $35^\circ\text{C}, 25^\circ\text{C}$ ).

**SCHEMATIC:**

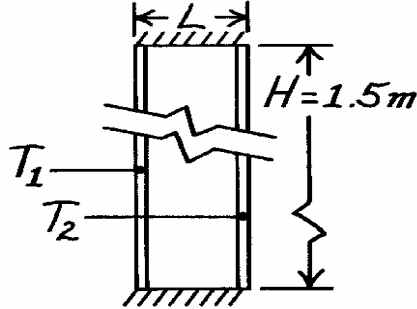

**ASSUMPTIONS:** (1) Steady-state conditions, (2) Radiation exchange is negligible, (3) Gases are at atmospheric pressure, (4) Perfect gas behavior.

**PROPERTIES:** Table A-4: Winter,  $\bar{T} = (-10 + 20)^\circ\text{C} / 2 = 288\text{ K}$ , Summer,  $\bar{T} = (35 + 25)^\circ\text{C} / 2 = 303\text{ K}$  :

Gas (1 atm)	$\bar{T}$ (K)	$\alpha$ ( $\text{m}^2/\text{s} \times 10^6$ )	$\nu$ ( $\text{m}^2/\text{s} \times 10^6$ )	$k \times 10^3$ (W/m·K)
Air	288	20.5	14.82	24.9
Air	303	22.9	16.19	26.5
CO <sub>2</sub>	288	10.2	7.78	15.74
CO <sub>2</sub>	303	11.2	8.55	16.78

**ANALYSIS:** The heat flux by convection across the window is

$$q'' = h(T_1 - T_2)$$

where the convection coefficient is estimated from the correlation of Eq. 9.53 for large aspect ratios  $10 < H/L < 40$ , for which  $\bar{h}$  is independent of  $L$ ,

$$\overline{\text{Nu}}_L = \bar{h}L/k = 0.046\text{Ra}_L^{1/3}.$$

Substituting numerical values for winter (w) and summer (s) conditions,

$$\text{Ra}_{L,w,\text{air}} = \frac{9.8\text{ m/s}^2 (1/288\text{ K})(20 - (-10))\text{ KL}^3}{20.5 \times 10^{-6}\text{ m}^2/\text{s} \times 14.82 \times 10^{-6}\text{ m}^2/\text{s}} = 3.360 \times 10^9 \text{ L}^3$$

$$\text{Ra}_{L,s,\text{air}} = 8.724 \times 10^8 \text{ L}^3 \quad \text{Ra}_{L,w,\text{CO}_2} = 1.286 \times 10^{10} \text{ L}^3 \quad \text{Ra}_{L,s,\text{CO}_2} = 3.378 \times 10^9 \text{ L}^3$$

the heat transfer coefficients are

$$\bar{h}_{w,\text{air}} = (0.0249\text{ W/m}\cdot\text{K/L}) \times 0.046 \left( 3.360 \times 10^9 \text{ L}^3 \right)^{1/3} = 1.72\text{ W/m}^2\cdot\text{K}$$

$$h_{s,\text{air}} = 1.16\text{ W/m}^2\cdot\text{K} \quad h_{w,\text{CO}_2} = 1.70\text{ W/m}^2\cdot\text{K} \quad h_{s,\text{CO}_2} = 1.16\text{ W/m}^2\cdot\text{K}.$$

Thus,

$$q''_{w,\text{air}} = 51.5\text{ W/m}^2 \quad q''_{s,\text{air}} = 11.6\text{ W/m}^2 \quad q''_{w,\text{CO}_2} = 50.9\text{ W/m}^2 \quad q''_{s,\text{CO}_2} = 11.6\text{ W/m}^2.$$

**COMMENTS:** (1) The correlation is valid for  $10^6 < \text{Ra}_L < 10^9$ . As an example, for a spacing  $L = 10$  mm, the Rayleigh number would be less than  $10^6$  in all four cases, and Eq. 9.52 should be used instead. However, note that  $H/L = 150$ , which is out of the range of validity of both correlations. (2) For this particular case, the smaller  $k$  for CO<sub>2</sub> is almost exactly offset by the smaller  $\alpha$  and  $\nu$  which lead to larger  $\text{Ra}_L$ , and there is very little difference between the results for air and CO<sub>2</sub>.

## PROBLEM 9.95

**KNOWN:** Dimensions of double pane window. Thickness of air gap. Temperatures of room and ambient air.

**FIND:** (a) Temperatures of glass panes and heat rate through window, (b) Resistance of glass pane relative to smallest convection resistance.

**SCHEMATIC:**

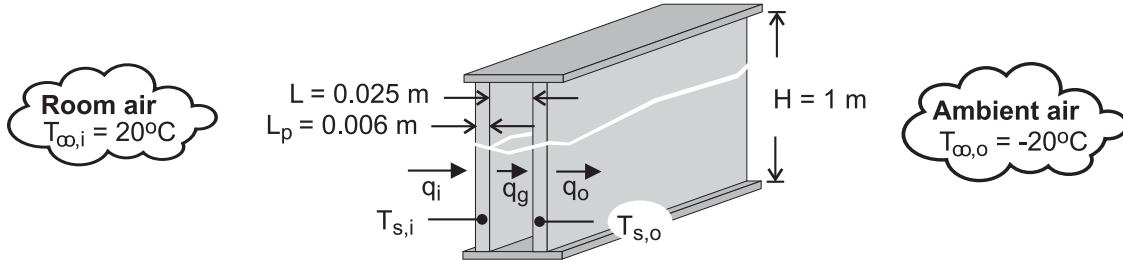

**ASSUMPTIONS:** (1) Steady-state, (2) Negligible glass pane thermal resistance, (3) Constant properties.

**PROPERTIES:** Table A-3, Plate glass:  $k_p = 1.4 \text{ W/m}\cdot\text{K}$ . Table A-4, Air ( $p = 1 \text{ atm}$ ).  $T_{f,i} = 287.6\text{K}$ :  $\nu_i = 14.8 \times 10^{-6} \text{ m}^2/\text{s}$ ,  $k_i = 0.0253 \text{ W/m}\cdot\text{K}$ ,  $\alpha_i = 20.9 \times 10^{-6} \text{ m}^2/\text{s}$ ,  $\text{Pr}_i = 0.710$ ,  $\beta_i = 0.00348 \text{ K}^{-1}$ .  $\bar{T} = (T_{s,i} + T_{s,o})/2 = 272.8\text{K}$ :  $\nu = 13.49 \times 10^{-6} \text{ m}^2/\text{s}$ ,  $k = 0.0241 \text{ W/m}\cdot\text{K}$ ,  $\alpha = 18.9 \times 10^{-6} \text{ m}^2/\text{s}$ ,  $\text{Pr} = 0.714$ ,  $\beta = 0.00367 \text{ K}^{-1}$ .  $T_{f,o} = 258.2\text{K}$ :  $\nu_o = 12.2 \times 10^{-6} \text{ m}^2/\text{s}$ ,  $k_o = 0.0230 \text{ W/m}\cdot\text{K}$ ,  $\alpha = 17.0 \times 10^{-6} \text{ m}^2/\text{s}$ ,  $\text{Pr} = 0.718$ ,  $\beta_o = 0.00387 \text{ K}^{-1}$ .

**ANALYSIS:** (a) The heat rate may be expressed as

$$q = q_o = \bar{h}_o H^2 (T_{s,o} - T_{\infty,o}) \quad (1)$$

$$q = q_g = \bar{h}_g H^2 (T_{s,i} - T_{s,o}) \quad (2)$$

$$q = q_i = \bar{h}_i H^2 (T_{\infty,i} - T_{s,i}) \quad (3)$$

where  $\bar{h}_o$  and  $\bar{h}_i$  may be obtained from Eq. (9.26),

$$\bar{\text{Nu}}_H = \left\{ 0.825 + \frac{0.387 \text{Ra}_H^{1/6}}{\left[ 1 + (0.492/\text{Pr})^{9/16} \right]^{8/27}} \right\}^2$$

with  $\text{Ra}_H = g\beta_o (T_{s,o} - T_{\infty,o}) H^3 / \alpha_o \nu_o$  and  $\text{Ra}_H = g\beta_i (T_{\infty,i} - T_{s,i}) H^3 / \alpha_i \nu_i$ , respectively. Assuming  $10^4 < \text{Ra}_L < 10^7$ ,  $\bar{h}_g$  is obtained from

$$\bar{\text{Nu}}_L = 0.42 \text{Ra}_L^{1/4} \text{Pr}^{0.012} (H/L)^{-0.3}$$

where  $\text{Ra}_L = g\beta (T_{s,i} - T_{s,o}) L^3 / \alpha \nu$ . A simultaneous solution to Eqs. (1) – (3) for the three unknowns yields

Continued ...

**PROBLEM 9.95 (Cont.)**

$$T_{s,i} = 9.1^\circ\text{C}, \quad T_{s,o} = -9.6^\circ\text{C}, \quad q = 35.7 \text{ W} \quad <$$

where  $\bar{h}_i = 3.29 \text{ W/m}^2 \cdot \text{K}$ ,  $\bar{h}_o = 3.45 \text{ W/m}^2 \cdot \text{K}$  and  $\bar{h}_g = 1.90 \text{ W/m}^2 \cdot \text{K}$ .

(b) The unit conduction resistance of a glass pane is  $R''_{\text{cond}} = L_p / k_p = 0.00429 \text{ m}^2 \cdot \text{K/W}$ , and the smallest convection resistance is  $R''_{\text{conv},o} = (1/\bar{h}_o) = 0.290 \text{ m}^2 \cdot \text{K/W}$ . Hence,

$$R''_{\text{cond}} \ll R''_{\text{conv},\text{min}} \quad <$$

and it is reasonable to neglect the thermal resistance of the glass.

**COMMENTS:** (1) Assuming a heat flux of  $35.7 \text{ W/m}^2$  through a glass pane, the corresponding temperature difference across the pane is  $\Delta T = q''(L_p / k_p) = 0.15^\circ\text{C}$ . Hence, the assumption of an isothermal pane is good. (2) Equations (1) – (3) were solved using the IHT workspace and the temperature-dependent air properties provided by the software. The property values provided in the PROPERTIES section of this solution were obtained from the software.

## PROBLEM 9.96

**KNOWN:** Top surface of an oven maintained at 60°C.

**FIND:** (a) Reduction in heat transfer from the surface by installation of a cover plate with specified air gap; temperature of the cover plate, (b) Effect of cover plate spacing.

**SCHEMATIC:**

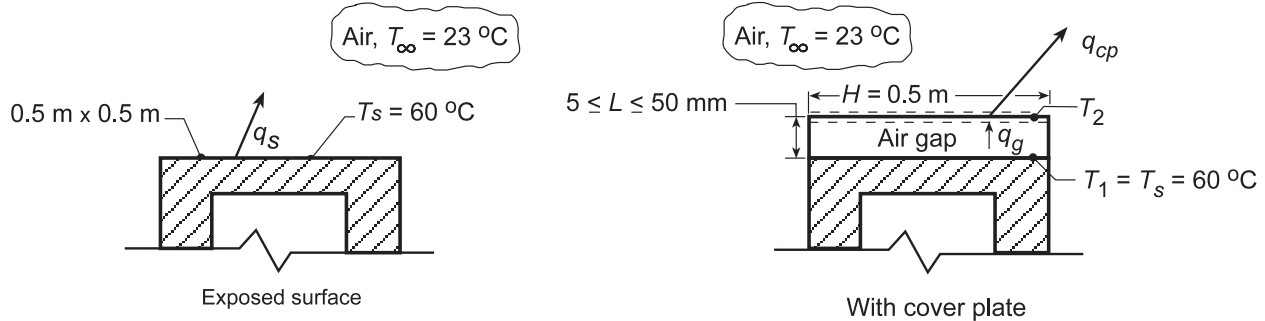

**ASSUMPTIONS:** (1) Steady-state conditions, (2) Oven surface at  $T_1 = T_s$  for both cases, (3) Negligible radiative exchange with surroundings and across air gap.

**PROPERTIES:** Table A.4, Air ( $T_f = (T_s + T_\infty)/2 = 315 \text{ K}$ , 1 atm):  $\nu = 17.40 \times 10^{-6} \text{ m}^2/\text{s}$ ,  $k = 0.0274 \text{ W/m}\cdot\text{K}$ ,  $\alpha = 24.7 \times 10^{-6} \text{ m}^2/\text{s}$ ; Table A.4, Air ( $\bar{T} = (T_1 + T_2)/2$  and  $T_{f2} = (T_2 + T_\infty)/2$ ): Properties obtained from *Correlations Toolpad* of IHT.

**ANALYSIS:** (a) The convective heat loss from the exposed top surface of the oven is  $q_s = \bar{h} A_s (T_s - T_\infty)$ . With  $L = A_s/P = (0.5 \text{ m})^2/(4 \times 0.5 \text{ m}) = 0.125 \text{ m}$ ,

$$Ra_L = \frac{g\beta\Delta T L^3}{\nu\alpha} = \frac{9.8 \text{ m/s}^2 (1/315 \text{ K})(60 - 23)^\circ \text{C} (0.125 \text{ m})^3}{17.40 \times 10^{-6} \text{ m}^2/\text{s} \times 24.7 \times 10^{-6} \text{ m}^2/\text{s}^2} = 5.231 \times 10^6.$$

The appropriate correlation for a heated plate facing upwards, Eq. 9.30, is

$$\overline{Nu}_L = \frac{\bar{h}L}{k} = 0.54 Ra_L^{1/4} \quad 10^4 \leq Ra_L \leq 10^7$$

$$\bar{h} = \left( \frac{0.0274 \text{ W/m}\cdot\text{K}}{0.125 \text{ m}} \right) \times 0.54 (5.231 \times 10^6)^{1/4} = 5.66 \text{ W/m}^2 \cdot \text{K}$$

Hence, the heat rate for the exposed surface is

$$q_s = 5.66 \text{ W/m}^2 \cdot \text{K} (0.5 \text{ m})^2 (60 - 23)^\circ \text{C} = 52.4 \text{ W} .$$

With the cover plate, the surface temperature ( $T_s = T_2$ ) is unknown and must be obtained by performing an energy balance at the top surface.

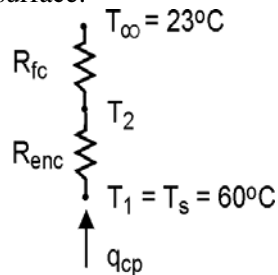

Continued...

### PROBLEM 9.96 (Cont.)

Equating heat flow across the gap to that from the top surface,  $q_g = q_{cp}$ . Hence, for a unit surface area,

$$\bar{h}_g (T_1 - T_2) = \bar{h}_{cp} (T_2 - T_\infty)$$

where  $\bar{h}_{cp}$  is obtained from Eq. 9.30 and  $\bar{h}_g$  is evaluated from Eq. 9.49.

$$\overline{Nu}_L = \frac{\bar{h}_g L}{k} = 0.069 Ra_L^{1/3} Pr^{0.074}$$

Entering this expression from the keyboard and Eq. 9.30 from the *Correlations* Toolpad, with the *Properties* Toolpad used to evaluate air properties at  $\bar{T}$  and  $T_{fs}$ , IHT was used with  $L = 0.05$  m to obtain

$$T_2 = 35.4^\circ\text{C} \qquad q_{cp} = 13.5 \text{ W} \qquad <$$

where  $\bar{h}_g = 2.2 \text{ W/m}^2 \cdot \text{K}$  and  $\bar{h}_{cp} = 4.4 \text{ W/m}^2 \cdot \text{K}$ . Hence, the effect of installing the cover plate creating the enclosure is to reduce the heat loss by

$$\frac{q_s - q_{cp}}{q_s} \times 100 = \frac{52.4 - 13.5}{52.4} \times 100 = 74\% . \qquad <$$

Note, however, that for  $L = 0.05$  m,  $Ra_L = 2.05 \times 10^5$  is slightly less than the lower limit of applicability for Eq. 9.49.

(b) If we use the foregoing model to evaluate  $T_2$  and  $q_{cp}$  for  $0.005 \leq L \leq 0.05$  m, we find that there is no effect. This seemingly unusual result is a consequence of the fact that, in Eq. 9.49,  $\overline{Nu}_L \propto Ra_L^{1/3}$ , in which case  $\bar{h}_g$  is independent of  $L$ . However,  $Ra_L$  and  $Nu_L$  do decrease with decreasing  $L$ , eventually approaching conditions for which transport across the airspace is determined by conduction and not convection. If transport is by conduction, the heat rate must be determined from Fourier's law, for which  $q_g'' = (k/L)(T_1 - T_2)$  and the equivalent, *pseudo*, Nusselt number is  $\overline{Nu}_L = \bar{h}L/k = 1$ . If this expression is used to determine  $\bar{h}_g$  in the energy balance,  $q_{cp}$  increases with decreasing  $L$ . The results would only apply if there is negligible advection in the airspace and hence for Rayleigh numbers less than 1708, which corresponds to  $L \approx 10.5$  mm. For this value of  $L$ ,  $q_{cp} = 15.4$  W exceeds that previously determined for  $L = 50$  mm. Hence, there is little variation in  $q_{cp}$  over the range  $10.5 < L < 50$  mm. However,  $q_{cp}$  increases with decreasing  $L$  below 10.5 mm, achieving a value of 24.2 W for  $L = 5$  mm. Hence, a value of  $L$  slightly larger than 10.5 mm could be considered an optimum.

**COMMENTS:** Radiation exchange across the cavity and with the surroundings is likely to be significant and should be considered in a more detailed analysis.

## PROBLEM 9.97

**KNOWN:** Dimensions of air space between windows, dimensions of individual blinds. Temperatures of windows.

**FIND:** Convection heat transfer rates between windows when the blinds are in the open and closed positions, respectively. Explanation of the small effect of the closed blinds on the convective heat transfer rate.

**SCHEMATIC:**

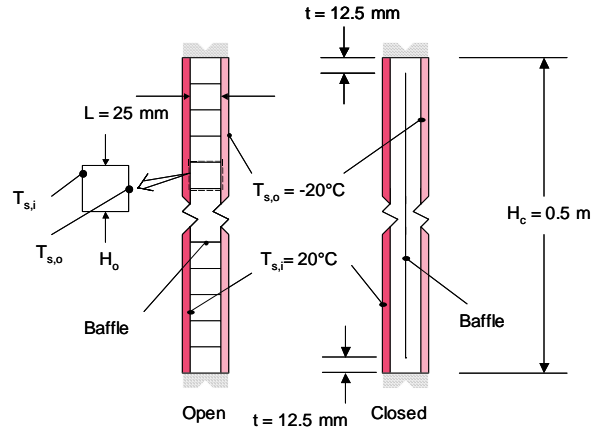

**ASSUMPTIONS:** (1) Constant properties, (2) Steady-state conditions, (3) Isothermal windows, (4) Blinds are adiabatic, (5) Neglect presence of the blind when in the closed position.

**PROPERTIES:** Table A.4, air: ( $T_f = 273 \text{ K}$ ):  $k = 0.02414 \text{ W/m}\cdot\text{K}$ ,  $\nu = 1.349 \times 10^{-5} \text{ m}^2/\text{s}$ ,  $\alpha = 1.894 \times 10^{-5} \text{ m}^2/\text{s}$ ,  $\text{Pr} = 0.714$ .

**ANALYSIS:**

Case A, Open Position The aspect ratio of a typical cell is  $H_o/L = 25/25 = 1$ . The Rayleigh number is

$$\text{Ra} = g\beta \frac{(T_{s,o} - T_{s,i})L^3}{\nu\alpha} = 9.8 \text{ m/s}^2 \times (1/273) \text{ K}^{-1} \times \frac{(20 - (-20))^\circ\text{C} \times (0.025 \text{ m})^3}{1.349 \times 10^{-5} \text{ m}^2/\text{s} \times 1.894 \times 10^{-5} \text{ m}^2/\text{s}} = 87.81 \times 10^3$$

and  $(\text{RaPr})/(0.2 + \text{Pr}) = (87.81 \times 10^3 \times 0.714)/(0.2 + 0.714) = 68,600$ . Therefore, Equation 9.51 may be used, resulting in

$$\overline{\text{Nu}}_L = 0.18 \left[ \frac{0.714}{(0.2 + 0.714)} \times 87.81 \times 10^3 \right]^{0.29} = 4.55 \quad \text{and}$$

$$\overline{h}_L = \overline{\text{Nu}}_L k / L = 4.55 \times 0.02414 \text{ W/m}\cdot\text{K} / 0.025 \text{ m} = 4.39 \text{ W/m}^2 \cdot \text{K}$$

The same value of the convection heat transfer coefficient exists for each cell. Hence,

Continued...



### PROBLEM 9.97 (Cont.)

$$q_{\text{conv}} = 4.39 \text{ W/m}^2 \cdot \text{K} \times 0.5 \text{ m} \times 0.5 \text{ m} \times (20^\circ\text{C} - (-20^\circ\text{C})) = 43.9 \text{ W} \quad <$$

Case B, Closed Position The aspect ratio of the cavity is  $H_c/L = 0.5 \text{ m}/0.025 \text{ m} = 20$ . The Rayleigh number is  $87.81 \times 10^3$ , as before. Therefore, select Equation 9.52, resulting in

$$\overline{\text{Nu}}_L = 0.42 \times (87.81 \times 10^3)^{1/4} \times (0.714)^{0.012} \times (20)^{-3} = 2.931$$

$$\bar{h}_L = \overline{\text{Nu}}_L k / L = 2.931 \times 0.02414 \text{ W/m} \cdot \text{K} / 0.025 \text{ m} = 2.83 \text{ W/m}^2 \cdot \text{K} \quad \text{Hence,}$$

$$q_{\text{conv}} = 2.83 \text{ W/m}^2 \cdot \text{K} \times 0.5 \text{ m} \times 0.5 \text{ m} \times (20^\circ\text{C} - (-20^\circ\text{C})) = 28.3 \text{ W} \quad <$$

The closed blinds may be neglected if the core of the air layer is nearly stagnant. <

**COMMENTS:** (1) Equation 9.52 has been extrapolated slightly outside of its range of application with respect to the suggested Prandtl number limits. (2) In the open blind case, recirculating flow will exist in each small square sub-enclosure, yielding larger values of the convection coefficient relative to the closed blind case. (3) The blind material will have a higher thermal conductivity than air, and the open blinds will serve as extended surfaces, further increasing heat loss through the window. Since the blinds will participate in the heat transfer when in the open position, treating the top and bottom surfaces of the small square sub-enclosures is an aggressive assumption. (4) Net radiation transfer between the two window surfaces will be greater for the open blind case.

## PROBLEM 9.98

**KNOWN:** Dimensions and surface temperatures of a flat-plate solar collector.

**FIND:** (a) Heat loss across collector cavity, (b) Effect of plate spacing on the heat loss.

**SCHEMATIC:**

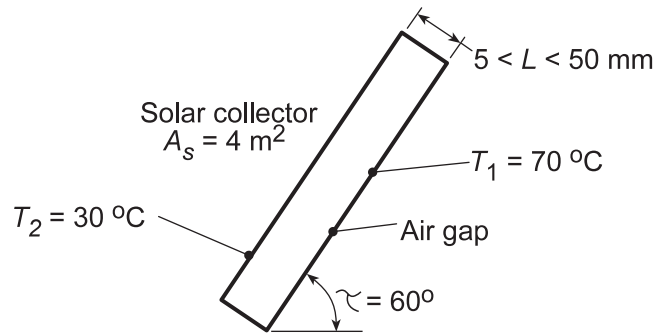

**ASSUMPTIONS:** Negligible radiation.

**PROPERTIES:** Table A.4, Air ( $\bar{T} = (T_1 + T_2)/2 = 323 \text{ K}$ ):  $\nu = 18.2 \times 10^{-6} \text{ m}^2/\text{s}$ ,  $k = 0.028 \text{ W/m}\cdot\text{K}$ ,  $\alpha = 25.9 \times 10^{-6} \text{ m}^2/\text{s}$ ,  $\beta = 0.0031 \text{ K}^{-1}$ .

**ANALYSIS:** (a) Since  $H/L = 2 \text{ m}/0.03 \text{ m} = 66.7 > 12$ ,  $\tau < \tau^*$  and Eq. 9.54 may be used to evaluate the convection coefficient associated with the air space. Hence,  $q = \bar{h} A_s (T_1 - T_2)$ , where  $\bar{h} = (k/L) \overline{\text{Nu}}_L$  and

$$\overline{\text{Nu}}_L = 1 + 1.44 \left[ 1 - \frac{1708}{\text{Ra}_L \cos \tau} \right] \cdot \left[ 1 - \frac{1708 (\sin 1.8\tau)^{1.6}}{\text{Ra}_L \cos \tau} \right] + \left[ \left( \frac{\text{Ra}_L \cos \tau}{5830} \right)^{1/3} - 1 \right]$$

For  $L = 30 \text{ mm}$ , the Rayleigh number is

$$\text{Ra}_L = \frac{g\beta(T_1 - T_2)L^3}{\alpha\nu} = \frac{9.8 \text{ m/s}^2 (0.0031 \text{ K}^{-1})(40^\circ \text{C})(0.03 \text{ m})^3}{25.9 \times 10^{-6} \text{ m}^2/\text{s} \times 18.2 \times 10^{-6} \text{ m}^2/\text{s}} = 6.96 \times 10^4$$

and  $\text{Ra}_L \cos \tau = 3.48 \times 10^4$ . It follows that  $\overline{\text{Nu}}_L = 3.12$  and  $\bar{h} = (0.028 \text{ W/m}\cdot\text{K}/0.03 \text{ m})3.12 = 2.91 \text{ W/m}^2\cdot\text{K}$ . Hence,

$$q = 2.91 \text{ W/m}^2\cdot\text{K} (4 \text{ m}^2) (40^\circ \text{C}) = 466 \text{ W} \quad \leftarrow$$

(b) The foregoing model was entered into the workspace of IHT, and results of the calculations are plotted as follows.

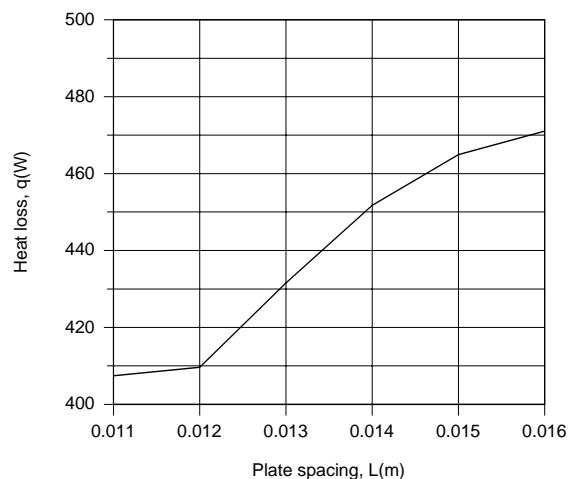
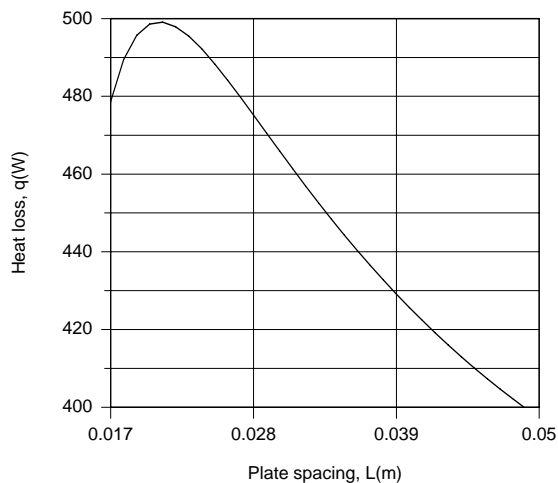

Continued...

### PROBLEM 9.98 (Cont.)

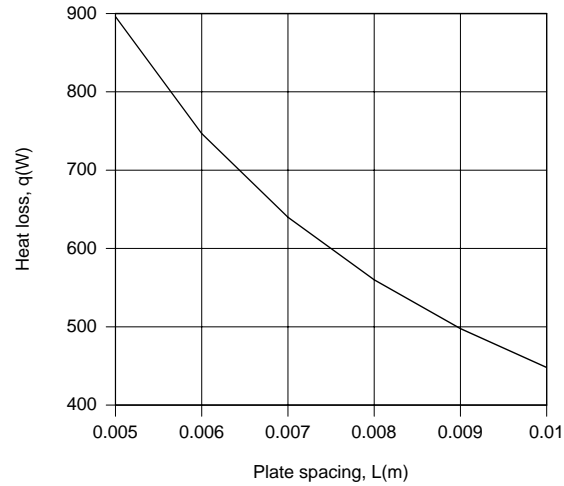

The plots are influenced by the fact that the third and second terms on the right-hand side of the correlation are set to zero at  $L \approx 0.017$  m and  $L \approx 0.011$  m, respectively. For the range of conditions, minima in the heat loss of  $q \approx 410$  W and  $q = 397$  W are achieved at  $L \approx 0.012$  m and  $L = 0.05$  m, respectively. Operation at  $L \approx 0.02$  m corresponds to a maximum and is clearly undesirable, as is operation at  $L < 0.011$  m, for which conditions are conduction dominated.

**COMMENTS:** Because the convection coefficient is low, radiation effects would be significant.

## PROBLEM 9.99

**KNOWN:** Cylindrical 120-mm diameter radiation shield of Example 9.5 installed concentric with a 100-mm diameter tube carrying steam; spacing provides for an air gap of  $L = 10$  mm.

**FIND:** (a) Heat loss per unit length of the tube by convection when a second shield of diameter 140 mm is installed; compare the result to that for the single shield calculation of the example; and (b) The heat loss per unit length if the gap dimension is made  $L = 15$  mm (rather than 10 mm). Do you expect the heat loss to increase or decrease?

**SCHEMATIC:**

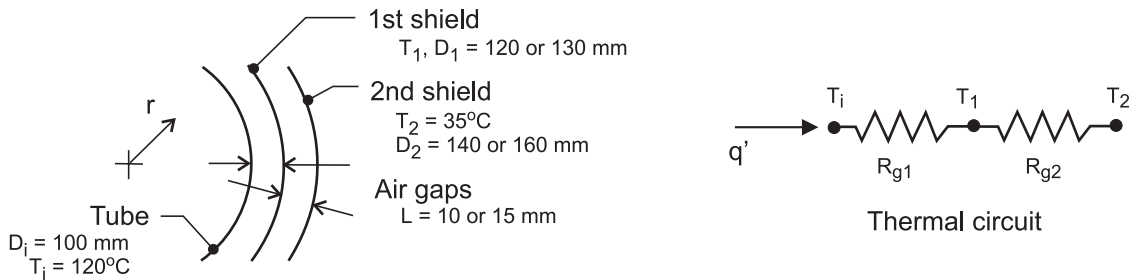

**ASSUMPTIONS:** (1) Steady-state conditions, and (b) Constant properties.

**PROPERTIES:** Table A-4, Air ( $T_f = (T_s + T_\infty)/2 = 350$  K, 1 atm):  $\nu = 20.92 \times 10^{-6}$  m<sup>2</sup>/s,  $k = 0.030$  W/m·K,  $Pr = 0.700$ .

**ANALYSIS:** (a) The thermal circuit representing the tube with two concentric cylindrical radiation shields having gap spacings  $L = 10$  mm is shown above. The heat loss per unit length by convection is

$$q' = \frac{T_i - T_2}{R'_{g1} + R'_{g2}} = \frac{T_i - T_1}{R'_{g1}} \quad (1)$$

where the  $R'_g$  represents the thermal resistance of the annular gap (spacing). From Eqs. 9.58, 59 and 60, find

$$R'_g = \frac{\ln(D_o/D_i)}{2\pi k_{\text{eff}}} \quad (2)$$

$$\frac{k_{\text{eff}}}{k} = 0.386 \left( \frac{Pr}{0.861 + Pr} \right)^{1/4} (Ra_c)^{1/4} \quad (3)$$

$$Ra_c = g\beta(T_o - T_i)L_c^3 / \alpha\nu \quad (4)$$

where  $L_c = \frac{2[\ln(r_o/r_i)]^{4/3}}{(r_i^{-3/5} + r_o^{-3/5})^{5/3}}$

where the properties are evaluated at the average temperature of the bounding surfaces,  $T_f = (T_i + T_o)/2$ . Recognize that the above system of equations needs to be solved iteratively by initial guess values of  $T_1$ , or solved simultaneously using equation-solving software with a properties library. The results are tabulated below.

Continued ...

### PROBLEM 9.99 (Cont.)

(b) Using the foregoing relations, the analyses can be repeated with  $L = 15$  mm, so that  $D_i = 130$  mm and  $D_2 = 160$  mm. The results are tabulated below along with those from Example 9.5 for the single-shield configuration.

Shields	L(mm)	$R'_{g1}$ (m·K/W)	$R'_{g2}$ (m·K/W)	$R'_{tot}$ (m·K/W)	$T_1$ (°C)	$q'$ (W/m)
1	10	0.7658	---	0.76	---	100
2	10	1.008	0.8855	1.89	74.8	44.9
2	15	0.9751	0.8224	1.80	73.9	47.3

**COMMENTS:** (1) The effect of adding the second shield is to more than double the thermal resistance of the shields to convection heat transfer.

(2) The effect of gap increase from 10 to 15 mm for the two-shield configuration is slight. Increasing  $L$  allows for greater circulation in the annular space, thereby reducing the thermal resistance.

(3) Note the difference in thermal resistances for the annular spaces  $R'_{g1}$  of the one-and two-shield configurations with  $L = 10$  mm. Why are they so different (0.7658 vs. 1.008 m·K/W, respectively)?

(4) See Example 9.5 for details on how to evaluate the properties for use with the correlation.

## PROBLEM 9.100

**KNOWN:** Concentric cylinders or concentric spheres of uniform inner and outer surface temperatures.

**FIND:** Expressions for the critical Rayleigh numbers,  $Ra_{c,crit}$  and  $Ra_{s,crit}$  below which  $k_{eff}$  is minimized. Evaluate  $Ra_{c,crit}$  and  $Ra_{s,crit}$  for air, water, and glycerin at a mean temperature of 300 K. Comment on the convection heat transfer rate associated with  $Ra_{c,crit}$  and  $Ra_{s,crit}$ .

**SCHEMATIC:**

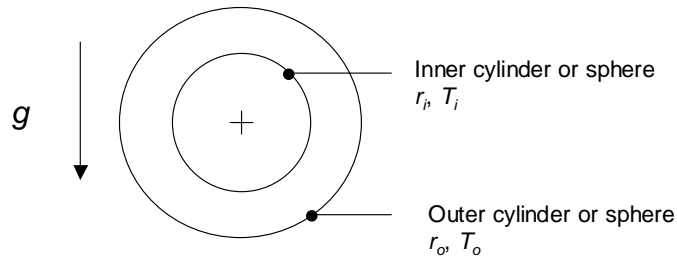

**ASSUMPTIONS:** (1) Constant properties.

**PROPERTIES:** Table A.4, air (300 K):  $Pr = 0.707$ . Table A.6 water (300 K):  $Pr = 5.83$ . Table A.5 glycerin (300 K):  $Pr = 6780$ .

**ANALYSIS:** When heat transfer across the gap is conduction-dominated,  $k_{eff} = k$ . When convection becomes significant,  $k_{eff}/k > 1$ . Hence, the minimum heat transfer rate occurs when  $k_{eff}/k = 1$ .

Concentric Cylinders: (Equation 9.59)

$$\frac{k_{eff}}{k} = 1 = 0.386 \left( \frac{Pr}{0.861 + Pr} \right)^{1/4} Ra_{c,crit}^{1/4} \quad \text{or} \quad Ra_{c,crit} = \left[ \frac{1}{0.386} \left( \frac{0.861 + Pr}{Pr} \right)^{1/4} \right]^4 = 45.0 \left( \frac{0.861 + Pr}{Pr} \right) <$$

Concentric Spheres: (Equation 9.62)

$$\frac{k_{eff}}{k} = 1 = 0.74 \left( \frac{Pr}{0.861 + Pr} \right)^{1/4} Ra_{s,crit}^{1/4} \quad \text{or} \quad Ra_{s,crit} = \left[ \frac{1}{0.74} \left( \frac{0.861 + Pr}{Pr} \right)^{1/4} \right]^4 = 3.33 \left( \frac{0.861 + Pr}{Pr} \right) <$$

For the three fluids of interest the critical Rayleigh numbers,  $Ra_{c,crit}$  and  $Ra_{s,crit}$  are:

	Concentric Cylinders, $Ra_{c,crit}$	Concentric Spheres, $Ra_{s,crit}$	<
Air	100	7.39	
Water	51.6	3.82	
Glycerin	45.0	3.33	

For specified inner and outer surface temperatures and inner surface radius, the heat transfer rates vary with the outer surface radius as shown in the figure on the following page. For Rayleigh numbers exceeding  $Ra_{c,crit}$  or  $Ra_{s,crit}$  the heat transfer rate increases as free convection becomes more vigorous. For Rayleigh numbers less than  $Ra_{c,crit}$  or  $Ra_{s,crit}$  conduction occurs within the fluid and the conduction heat transfer rate increases as the gap between the surfaces becomes small. Hence conditions associated with  $Ra_{c,crit}$  or  $Ra_{s,crit}$  correspond to the minimum heat transfer rate.

Continued...

### PROBLEM 9.100 (Cont.)

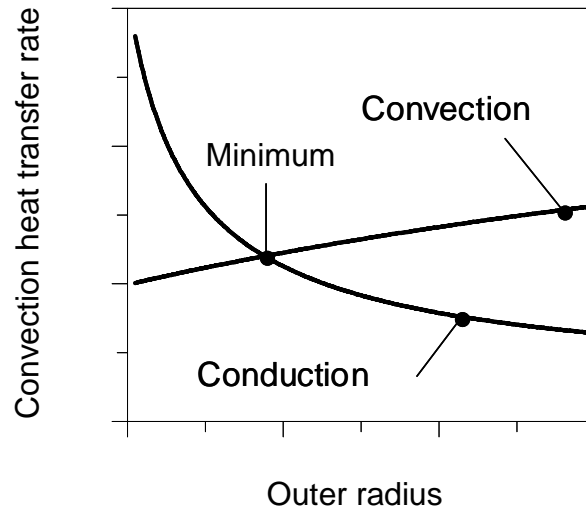

**COMMENTS:** (1) For glycerin, both correlations have been extrapolated slightly beyond the recommended upper limit of the Prandtl number. (2) The critical Rayleigh numbers for the cylinder are substantially larger than those for the sphere. This reflects the fact that, for a given  $r_o/r_i$  ratio, the concentric sphere arrangement has a lower surface area to gas volume ratio than the concentric cylinder arrangement. Hence, the fluid is less constrained by the no-slip boundary conditions of the solid surfaces in the concentric sphere geometry.

### PROBLEM 9.101

**KNOWN:** Operating conditions of a concentric tube solar collector.

**FIND:** Convection heat transfer per unit length across air space between tubes.

**SCHEMATIC:**

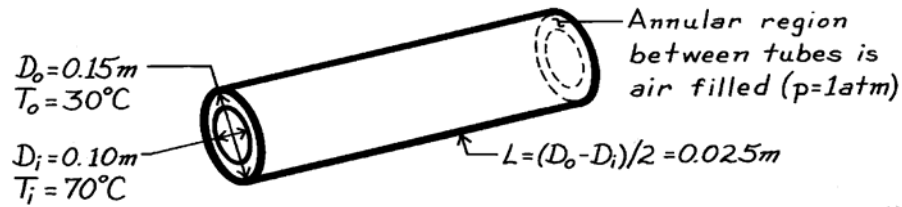

**ASSUMPTIONS:** (1) Steady-state conditions, (2) Long tubes.

**PROPERTIES:** Table A-4, Air ( $T = 50^\circ\text{C}$ , 1 atm):  $\nu = 18.2 \times 10^{-6} \text{ m}^2/\text{s}$ ,  $k = 0.028 \text{ W/m}\cdot\text{K}$ ,  $\alpha = 25.9 \times 10^{-6} \text{ m}^2/\text{s}$ ,  $\text{Pr} = 0.71$ ,  $\beta = 0.0031 \text{ K}^{-1}$ .

**ANALYSIS:** The length scale in  $\text{Ra}_c$  is given by Eq. 9.60,

$$L_c = \frac{2[\ln(r_o/r_i)]^{4/3}}{(r_i^{-3/5} + r_o^{-3/5})^{5/3}} = \frac{2[\ln(0.075/0.05)]^{4/3}}{[(0.075 \text{ m})^{-3/5} + (0.05 \text{ m})^{-3/5}]^{5/3}} = 0.0114 \text{ m}$$

Then

$$\text{Ra}_c = \frac{g\beta(T_s - T_\infty)L_c^3}{\nu\alpha} = \frac{9.8 \text{ m/s}^2 \times 0.0031 \text{ K}^{-1} (70 - 30)^\circ\text{C} (0.0114 \text{ m})^3}{18.2 \times 10^{-6} \text{ m}^2/\text{s} \times 25.9 \times 10^{-6} \text{ m}^2/\text{s}} = 3860$$

Next, Eq. 9.59 may be used, in which case

$$k_{\text{eff}} = 0.386k \left( \frac{\text{Pr}}{0.861 + \text{Pr}} \right)^{1/4} (\text{Ra}_c)^{1/4}$$

$$k_{\text{eff}} = 0.386(0.028 \text{ W/m}\cdot\text{K}) \left( \frac{0.71}{0.861 + 0.71} \right)^{1/4} (3860)^{1/4} = 0.07 \text{ W/m}\cdot\text{K}.$$

From Eq. 9.58, it then follows that

$$q' = \frac{2\pi k_{\text{eff}}}{\ln(r_o/r_i)} (T_i - T_o) = \frac{2\pi(0.07 \text{ W/m}\cdot\text{K})}{\ln(0.15/0.10)} (70 - 30)^\circ\text{C} = 43.4 \text{ W/m}. \quad <$$

**COMMENTS:** An additional heat loss is related to thermal radiation exchange between the inner and outer surfaces.



## PROBLEM 9.102

**KNOWN:** Concentric cylinders. Radius of inner cylinder. Temperature of inner cylinder and ambient temperature.

**FIND:** Outer diameter for minimizing heat loss. Comparison of the heat loss to the situation with no outer cylinder.

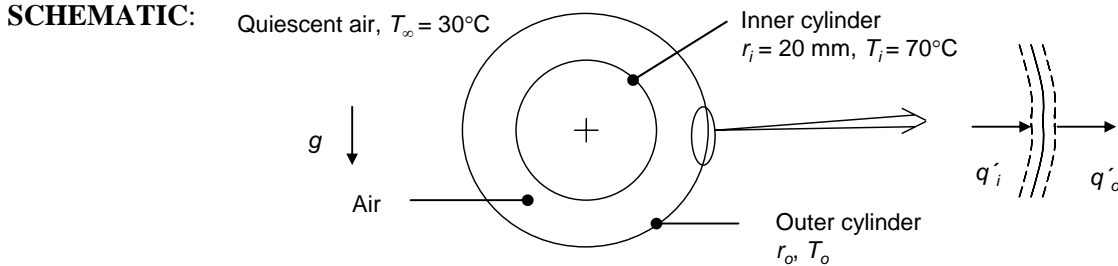

**ASSUMPTIONS:** (1) Constant properties, (2) Negligible radiation heat transfer, (3) Steady state, (4) Isothermal and thin outer cylinder, (5) Quiescent environment.

**PROPERTIES:** Table A.4, air ( $50^\circ\text{C} = 323 \text{ K}$ ):  $k = 0.028 \text{ W/m}\cdot\text{K}$ ,  $\alpha = 2.59 \times 10^{-5} \text{ m}^2/\text{s}$ ,  $\nu = 1.82 \times 10^{-5} \text{ m}^2/\text{s}$ ,  $\beta = 0.003096 \text{ K}^{-1}$ ,  $Pr = 0.704$ .

**ANALYSIS:** Neither the radius of the outer cylinder nor the temperature of the outer cylinder is specified. Therefore, an iterative process must be used in order to solve for the optimal radius of the outer cylinder and its temperature. Furthermore, it is not known whether the fluid motion in the annulus is vigorous enough to produce an effective thermal conductivity that is greater than unity. Hence, the analysis will be carried out based upon the assumption of either conduction or convection occurring in the gap; the actual situation corresponds to the larger heat transfer rate per unit length.

For the exterior of the outer cylinder,  $q'_o = h_o 2\pi r_o (T_o - T_\infty) = h_o 2\pi r_o (T_o - 30^\circ\text{C})$  (1)

and the Churchill and Chu correlation may be used to evaluate  $h_o$ ,

$$h_o = \frac{0.028 \text{ W/m}\cdot\text{K}}{2r_o} \left\{ 0.60 + \frac{0.387 Ra_D^{1/6}}{\left[ 1 + (0.559/0.704)^{9/16} \right]^{8/27}} \right\}^2 \quad (2)$$

where

$$Ra_D = \frac{g\beta(T_o - T_\infty)(2r_o)^3}{\nu\alpha} = \frac{9.81 \text{ m/s}^2 \cdot 0.003096 \text{ K}^{-1} (T_o - 30^\circ\text{C})(2r_o)^3}{1.82 \times 10^{-5} \text{ m}^2/\text{s} \times 2.59 \times 10^{-5} \text{ m}^2/\text{s}} \quad (3)$$

For the annular region between the cylinders,

$$q'_i = \frac{2\pi k_{\text{eff}}(T_i - T_o)}{\ln(r_o/r_i)} = \frac{2\pi k_{\text{eff}}(70^\circ\text{C} - T_o)}{\ln(r_o/0.020 \text{ m})} \quad (4)$$

where the Raithby and Hollands formulation may be used to determine the value of  $k_{\text{eff}}$ ,

Continued...

### PROBLEM 9.102 (Cont.)

$$k_{\text{eff}} = 0.386k \left( \frac{Pr}{0.861 + Pr} \right)^{1/4} Ra_c^{1/4} = 0.386 \times 0.028 \text{ W/m} \cdot \text{K} \left( \frac{0.704}{0.861 + 0.704} \right) Ra_c^{1/4} \quad (5)$$

The characteristic length in the Rayleigh number is

$$L_c = \frac{2[\ln(r_o/r_i)]^{4/3}}{(r_i^{-3/5} + r_o^{-3/5})^{5/3}} = \frac{2[\ln(r_o/0.020 \text{ m})]^{4/3}}{((0.020 \text{ m})^{-3/5} + r_o^{-3/5})^{5/3}} \quad (6)$$

and 
$$Ra_c = g\beta(T_i - T_o)L_c^3/\nu\alpha. \quad (7)$$

From the surface energy balance shown in the schematic,

$$q'_i = q'_o \quad (8)$$

Equations 1 through 8 include 9 unknowns,  $q'_i$ ,  $q'_o$ ,  $L_c$ ,  $r_o$ ,  $T_o$ ,  $k_{\text{eff}}$ ,  $Ra_D$ ,  $Ra_c$ , and  $h_o$ . IHT was used to solve these equations simultaneously over a range of  $r_o$ , and the results are plotted below.

For small gap widths, it is expected that augmentation of heat transfer rates due to free convection in the annulus will be small. For these cases,

$$k_{\text{eff}} = k = 0.028 \text{ W/m} \cdot \text{K} \quad (8)$$

Equations 1 through 4, 7 and 8 may be solved simultaneously for  $q'_i$ ,  $q'_o$ ,  $r_o$ ,  $T_o$  and  $h_o$ . IHT was used to solve the equations, and to plot the results shown below.

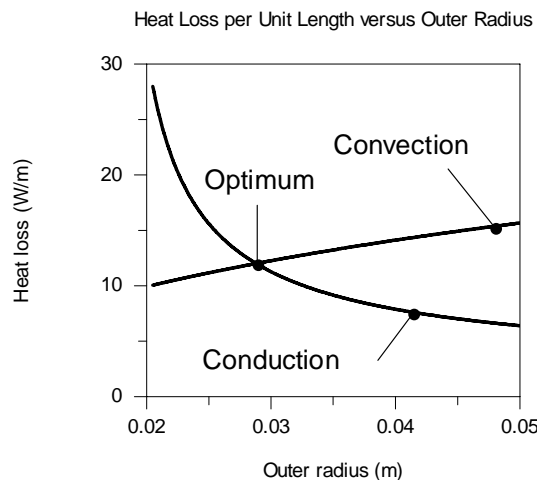

Heat losses are calculated based upon the two assumptions of (i) convection in the annulus and (ii) conduction in the annulus. The actual heat loss sensitivity to the outer cylinder radius follows the conduction curve until the optimum point is reached, then follows the convection curve after the optimal outer radius. From IHT it is determined that the optimal outer radius is

$$r_{o,\text{opt}} = 0.0289 \text{ m} = 28.9 \text{ mm}, \text{ yielding a heat transfer rate of } q' = 11.99 \text{ W/m.} \quad \leftarrow$$

Continued...

## PROBLEM 9.102 (Cont.)

Without the outer cylinder, the heat loss is determined by the Raithby and Hollands formula with

$$Ra_D = \frac{g\beta(T_i - T_\infty)(2r_i)^3}{\nu\alpha} = \frac{9.81 \text{ m/s}^2 \cdot 0.003096 \text{ K}^{-1} (70^\circ\text{C} - 30^\circ\text{C})(0.040\text{m})^3}{1.82 \times 10^{-5} \text{ m}^2/\text{s} \times 2.59 \times 10^{-5} \text{ m}^2/\text{s}} = 165 \times 10^3$$

Hence,

$$h = \frac{0.028 \text{ W/m} \cdot \text{K}}{0.040 \text{ m}} \left\{ 0.060 + \frac{0.387 (165 \times 10^3)^{1/6}}{\left[ 1 + (0.559/0.707)^{9/16} \right]^{8/27}} \right\}^2 = 4.16 \text{ W/m}^2 \cdot \text{K}$$

and  $q' = 2\pi r_i h (T_i - T_\infty) = 2\pi \times 0.02 \text{ m} \times 4.16 \text{ W/m}^2 \cdot \text{K} \times (70^\circ\text{C} - 30^\circ\text{C}) = 20.9 \text{ W/m}$ . <

The scheme reduces the convective heat transfer loss by  $[(20.9 - 12)/20.9] \times 100 = 43 \%$ . The scheme is somewhat effective.

**COMMENTS:** (1) For the outer cylinder of optimal radius, the surface temperature is  $T_o = 44.9^\circ\text{C}$ . The Rayleigh number for the outer cylinder is  $1.9 \times 10^5$ . (2) The IHT code is shown below.

```
// Air property functions : From Table A.4
// Units: T(K); 1 atm pressure
rho = rho_T("Air",T) // Density, kg/m^3
cp = cp_T("Air",T) // Specific heat, J/kg-K
mu = mu_T("Air",T) // Viscosity, N-s/m^2
nu = nu_T("Air",T) // Kinematic viscosity, m^2/s
k = k_T("Air",T) // Thermal conductivity, W/m-K
alpha = alpha_T("Air",T) // Thermal diffusivity, m^2/s
Pr = Pr_T("Air",T) // Prandtl number
beta = 1/T // Volumetric coefficient of expansion, K^-1; ideal gas

g = 9.8 //gravitational acceleration, m/s^2

//Thermal Conditions and Geometry

Ti = 70 + 273 //Inner cylinder temperature, K
Tinf = 30 + 273 //Ambient temperature, K
T = (Ti + Tinf)/2 //Average temperature, K
ri = 20/1000 //Inner cylinder radius, m
ro = 30/1000 //Outer cylinder radius, m

//Convection in Annular Region
Lc = num/den
num = 2*(ln(ro/ri))^(4/3)
den = (ri^-0.6 + ro^-0.6)^(5/3)
Rac = g*beta*(Ti - Tocv)*Lc^3/nu/alpha
keff = k*0.386*((Pr/(0.861 + Pr))^0.25)*Rac^0.25
qcv = 2*pi*keff*(Ti - Tocv)/ln(ro/ri)
//Tocv is the outer cylinder temperature with convection in the annulus, K
//qcv is the convection heat transfer per unit cylinder length inside the annulus. W/m

//Conduction in Annular Region
qcd = 2*pi*k*(Ti - Tocd)/ln(ro/ri)
//Tocd is the outer cylinder temperature with conduction in the annulus
//qcd is the conduction heat transfer per unit cylinder length inside the annulus, W/m
```

Continued...

## PROBLEM 9.102 (Cont.)

//Exterior Free Convection

```
D = 2*ro //Cylinder diameter, m
RaDcv = g*beta*(Tocv - Tinf)*D^3/nu/alpha //External Rayleigh number for convection in annulus
RaDcd = g*beta*(Tocd - Tinf)*D^3/nu/alpha //External Rayleigh number for conduction in annulus
NuDcv = NuD_bar_FC_HC(RaDcv,Pr) // Eq 9.34, Exterior Nusselt number with convection in annulus
NuDcd = NuD_bar_FC_HC(RaDcd,Pr) // Eq 9.34 Exterior Nusselt number with conduction in annulus
hDcv = NuDcv*k/D //External convection coefficient coinciding with convection in the annulus
hDcd = NuDcd*k/D //External convection coefficient coinciding with conduction in the annulus

qcv = hDcv*pi*D*(Tocv - Tinf) //External convection heat transfer per unit length (with convection in annulus), W/m
qcd = hDcd*pi*D*(Tocd - Tinf) //External convection heat transfer per unit length (with conduction in annulus), W/m
```

## PROBLEM 9.103

**KNOWN:** Dimensions and heat generation rate associated with horizontally-oriented lithium ion battery. Size of annulus filled with liquid paraffin. Properties and fusion temperature of the paraffin.

**FIND:** (a) Battery surface temperature when  $r_o = 19$  mm, (b) Rate at which  $r_o$  is increasing with time, (c) Plot of battery surface temperature versus  $r_o$  for  $15 \text{ mm} \leq r_o \leq 30 \text{ mm}$  and explanation of relative insensitivity of battery temperature to size of the annulus.

**SCHEMATIC:**

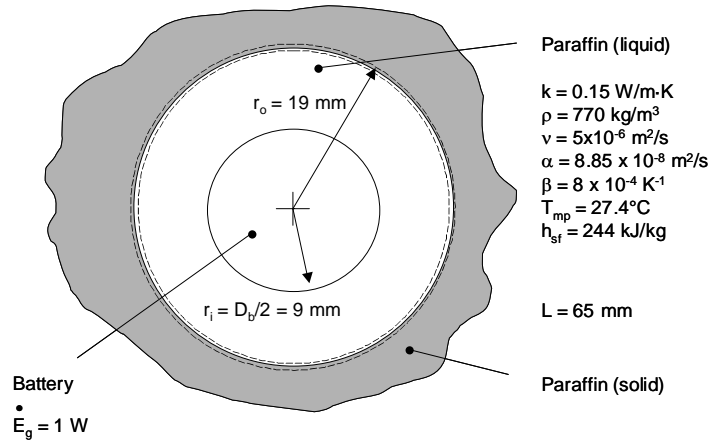

**ASSUMPTIONS:** (1) Constant properties and steady-state conditions, (2) Solid paraffin at melting point temperature.

**PROPERTIES:** Given, see schematic.

**ANALYSIS:** (a) The length scale used in the Rayleigh number is given by Equation 9.60.

$$L_c = \frac{2[\ln(r_o/r_i)]^{4/3}}{(r_i^{-3/5} + r_o^{-3/5})^{5/3}} = \frac{2[\ln(19/9)]^{4/3}}{\left[(9 \times 10^{-3} \text{ m})^{-3/5} + (19 \times 10^{-3} \text{ m})^{-3/5}\right]^{5/3}} = 5.36 \times 10^{-3} \text{ m}$$

The Rayleigh number is

$$\begin{aligned} \text{Ra}_c &= \frac{g\beta(T_s - T_{\text{mp}})L_c^3}{\nu \cdot \alpha} = \frac{9.8 \text{ m/s}^2 \times 8 \times 10^{-4} \text{ K}^{-1} \times (T_s - 27.4)^\circ\text{C} \times (5.36 \times 10^{-3} \text{ m})^3}{5 \times 10^{-6} \text{ m}^2/\text{s} \times 8.85 \times 10^{-8} \text{ m}^2/\text{s}} \quad (1) \\ &= 2728 \text{ K}^{-1} \times (T_s - 27.4^\circ\text{C}) \end{aligned}$$

The Prandtl number is  $\text{Pr} = \nu/\alpha = 5 \times 10^{-6} \text{ m}^2/\text{s} / 8.85 \times 10^{-8} \text{ m}^2/\text{s} = 56.5$ , and the effective thermal conductivity is given by Equation 9.59,

Continued...

**PROBLEM 9.103 (Cont.)**

$$k_{\text{eff}} = 0.386k \left( \frac{\text{Pr}}{0.861 + \text{Pr}} \right)^{1/4} \text{Ra}_c^{1/4} = 0.386 \times 0.15 \text{ W/m} \cdot \text{K} \times \left( \frac{56.5}{0.861 + 565} \right)^{1/4} \text{Ra}_c^{1/4}$$

$$k_{\text{eff}} = 0.0577 \text{ Ra}_c^{1/4} \quad (2)$$

The effective thermal conductivity may also be expressed in terms of Equation 9.58,

$$k_{\text{eff}} = \frac{\dot{E}_g \ln(r_o/r_i)}{2\pi L(T_s - T_{\text{mp}})} = \frac{1 \text{ W} \times \ln(19/9)}{2\pi \times 65 \times 10^{-3} \text{ m} \times (T_s - 27.4^\circ\text{C})} = \frac{1.829 \text{ W/m}}{(T_s - 27.4^\circ\text{C})} \quad (3)$$

Equations 1, 2 and 3 may be solved simultaneously to yield

$$\text{Ra}_c = 8901, k_{\text{eff}} = 0.5603 \text{ W/m} \cdot \text{K}, T_s = 30.7^\circ\text{C}. \quad <$$

(b) An energy balance on the control surface shown in the schematic yields

$$q_{\text{conv}} = \dot{E}_g = A \rho h_{\text{sf}} dr_o / dt$$

or

$$\begin{aligned} \frac{dr_o}{dt} &= \frac{\dot{E}_g}{2\pi r_o L \rho h_{\text{sf}}} = \frac{1 \text{ W}}{2 \times \pi \times 19 \times 10^{-3} \text{ m} \times 65 \times 10^{-3} \text{ m} \times 770 \text{ kg/m}^3 \times 244 \times 10^3 \text{ J/kg}} < \\ &= 685 \times 10^{-9} \text{ m/s} = 0.685 \mu\text{m/s} \end{aligned}$$

(c) Equations 1 through 3 may be re-solved for various outer radii of the annular region. As evident, the battery surface temperature is very insensitive to the size of the annular region. If heat transfer in the annulus were conduction-dominated, one would expect the battery surface temperature to *increase* as the annulus becomes larger. The opposite trend is evident here.

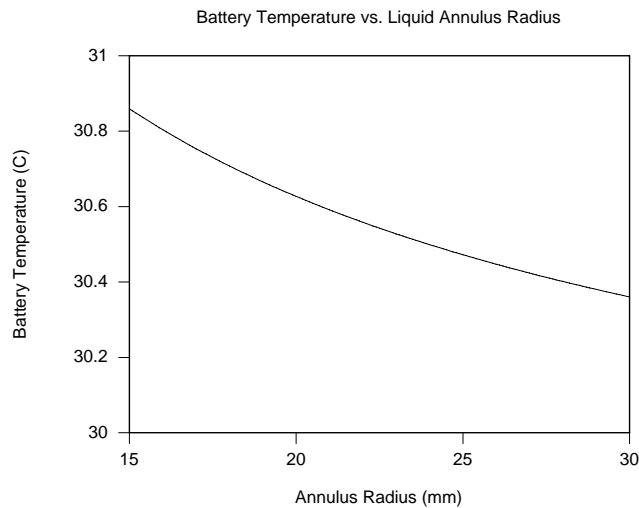

Continued...

### PROBLEM 9.103 (Cont.)

As the annulus becomes larger, fluid velocities associated with free convection increase and the effective thermal conductivity is expected to increase as well. The ratio of the effective thermal conductivity to the bulk thermal conductivity of the paraffin and its sensitivity to the size of the annulus is shown in the plot below. The enhanced fluid motion associated with the larger enclosures increases the effective thermal conductivity of the fluid significantly. Hence, both the numerator and denominator of Equation 9.58 increase with increasing size of the annular region, yielding relatively constant battery surface temperatures.

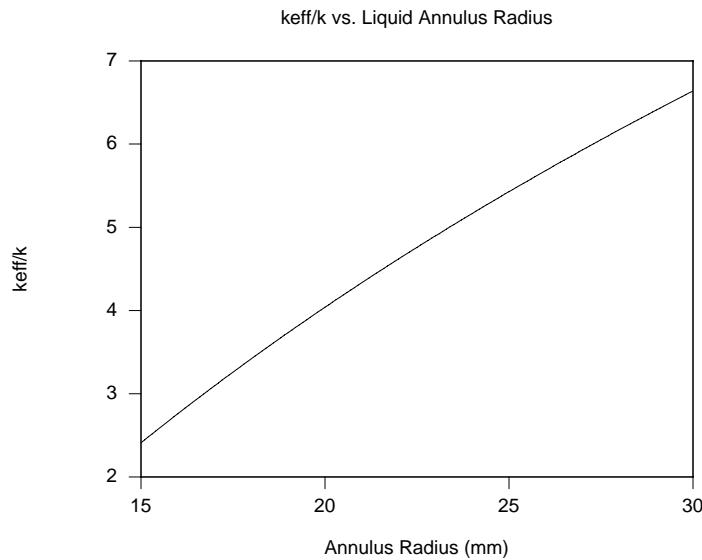

### PROBLEM 9.104

**KNOWN:** Temperatures of concentric spheres and diameter of inner sphere.

**FIND:** Outer sphere diameter required so that convection heat transfer is same as for inner sphere in a large, quiescent environment at 20°C.

**SCHEMATIC:**

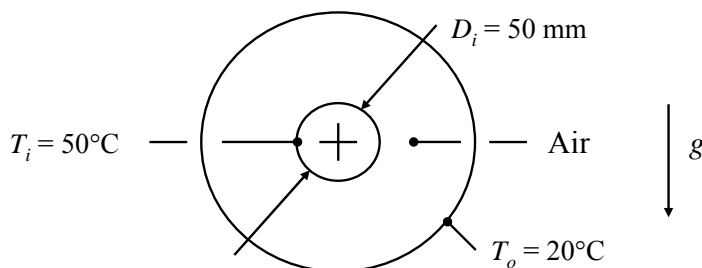

**ASSUMPTIONS:** (1) Steady-state, (2) Uniform sphere surface temperatures, (3) Constant properties.

**PROPERTIES:** Table A-4, Air ( $T = 308 \text{ K}$ ):  $\nu = 16.69 \times 10^{-6} \text{ m}^2/\text{s}$ ,  $\alpha = 23.68 \times 10^{-6} \text{ m}^2/\text{s}$ ,  $k = 26.9 \times 10^{-3} \text{ W/m} \cdot \text{K}$ ,  $Pr = 0.706$ ,  $\beta = 1/T = 0.00325 \text{ K}^{-1}$ .

**ANALYSIS:** For the single inner sphere in a large quiescent enclosure, the Rayleigh number based on inner diameter is

$$Ra_D = \frac{g\beta(T_i - T_\infty)D_i^3}{\nu\alpha} = \frac{9.8 \text{ m/s}^2 \times 0.00325 \text{ K}^{-1} \times (50 - 20)^\circ\text{C} \times (0.05 \text{ m})^3}{16.69 \times 10^{-6} \text{ m}^2/\text{s} \times 23.68 \times 10^{-6} \text{ m}^2/\text{s}} = 3.02 \times 10^5$$

Eq. 9.35 holds, and yields

$$\overline{Nu}_D = 2 + \frac{0.589 Ra_D^{1/4}}{[1 + (0.469 / Pr)^{9/16}]^{4/9}} = 12.7$$

and

$$q_1 = \bar{h}\pi D_i^2(T_i - T_\infty) = \overline{Nu}_D k \pi D_i(T_i - T_\infty) = 12.7 \times 26.9 \times 10^{-3} \text{ W/m} \cdot \text{K} \times \pi \times 0.05 \text{ m} \times (50 - 20)^\circ\text{C} = 1.60 \text{ W}$$

For the concentric spheres, the Rayleigh number is based on the length scale given by Eq. 9.63,

$$Ra_s = \frac{g\beta(T_i - T_o)}{\nu\alpha} \frac{(1/r_i - 1/r_o)^4}{2(r_i^{-7/5} + r_o^{-7/5})^5} \quad (1)$$

Substituting this into Eq. 9.62 and substituting Eq. 9.62 in Eq. 9.61 yields

Continued...



**PROBLEM 9.104 (Cont.)**

$$\begin{aligned}
 q_2 &= 4\pi k(T_i - T_o)0.74 \left( \frac{Pr}{0.861 + Pr} \right)^{1/4} \left( \frac{g\beta(T_i - T_o)}{\nu\alpha} \right)^{1/4} \frac{1}{2^{1/4}(r_i^{-7/5} + r_o^{-7/5})^{5/4}} \quad (2) \\
 &= 4\pi \times 26.9 \times 10^{-3} \text{ W/m} \cdot \text{K} \times (50 - 20)^\circ\text{C} \times 0.74 \times \left( \frac{0.706}{0.861 + 0.706} \right)^{1/4} \\
 &\quad \times \left( \frac{9.8 \text{ m/s}^2 \times 0.00325 \text{ K}^{-1} \times (50 - 20)^\circ\text{C}}{16.69 \times 10^{-6} \text{ m}^2/\text{s} \times 23.68 \times 10^{-6} \text{ m}^2/\text{s}} \right)^{1/4} \frac{1}{2^{1/4}(r_i^{-7/5} + r_o^{-7/5})^{5/4}} \\
 &= 1146 \text{ W/m}^{7/4} \frac{1}{(r_i^{-7/5} + r_o^{-7/5})^{5/4}}
 \end{aligned}$$

Setting  $q_2 = q_1 = 1.60 \text{ W}$ , and solving for  $r_o$  yields

$$r_o = \left[ \left( \frac{1146 \text{ W/m}^{7/4}}{1.60 \text{ W}} \right)^{4/5} - r_i^{-7/5} \right]^{-5/7} = \left[ \left( \frac{1146 \text{ W/m}^{7/4}}{1.60 \text{ W}} \right)^{4/5} - (0.025 \text{ m})^{-7/5} \right]^{-5/7} = 0.130 \text{ m}$$

Thus the required diameter of the outer cylinder is

$$D_o = 260 \text{ mm} \quad <$$

From Eq. (1),  $Ra_s = 5000$ , so the correlation for concentric spheres is within its range of applicability.

**COMMENTS:** It is of interest whether the concentric sphere correlation approaches the single sphere limit as  $r_o \rightarrow \infty$ . From Eq. (2) above, it can be seen that  $q_2$  reaches an asymptote. This can be rephrased in terms of a heat transfer coefficient for concentric spheres,  $h_2$ , defined such that  $q_2 = h_2 \pi D_i^2 (T_i - T_o)$ . The corresponding Nusselt number,  $\overline{Nu}_D = h_2 D_i / k$ , is then

$$\overline{Nu}_D = \frac{0.74 Ra_D^{1/4}}{(1 + 0.861 / Pr)^{1/4}}$$

This has the same asymptotic Rayleigh number dependence as Eq. 9.35 (as long as the leading 2 is negligible), but not the same Prandtl number dependence. When researchers fit experimental data to a correlating equation, they must make a judgment as to whether it is appropriate, based on the range of their experimental data, to impose the correct limiting behavior.

### PROBLEM 9.105

**KNOWN:** Annulus formed by two concentric, horizontal tubes with prescribed diameters and surface temperatures is filled with nitrogen at 5 atm.

**FIND:** Convective heat transfer rate per unit length of the tubes.

**SCHEMATIC:**

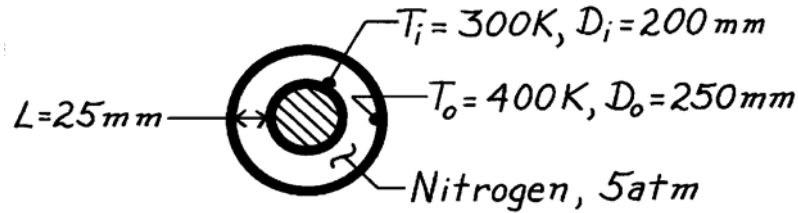

**ASSUMPTIONS:** (1) Thermophysical properties  $k$ ,  $\mu$ , and  $Pr$ , are independent of pressure, (2) Density is proportional to pressure, (3) Perfect gas behavior.

**PROPERTIES:** Table A-4, Nitrogen ( $\bar{T} = (T_i + T_o)/2 = 350\text{K}$ , 5 atm):  $k = 0.0293\text{ W/m}\cdot\text{K}$ ,  $\mu = 200 \times 10^{-7}\text{ N}\cdot\text{s/m}^2$ ,  $\rho(5\text{ atm}) = 5\rho(1\text{ atm}) = 5 \times 0.9625\text{ kg/m}^3 = 4.813\text{ kg/m}^3$ ,  $Pr = 0.711$ ,  $\nu = \mu/\rho = 4.155 \times 10^{-6}\text{ m}^2/\text{s}$ ,  $\alpha = k/\rho c = 0.0293\text{ W/m}\cdot\text{K}/(4.813\text{ kg/m}^3 \times 1042\text{ J/kg}\cdot\text{K}) = 5.842 \times 10^{-6}\text{ m}^2/\text{s}$ .

**ANALYSIS:** The length scale in  $Ra_c$  is given by Eq. 9.60,

$$L_c = \frac{2[\ln(r_o/r_i)]^{4/3}}{(r_i^{-3/5} + r_o^{-3/5})^{5/3}} = \frac{2[\ln(125/100)]^{4/3}}{[(0.1\text{ m})^{-3/5} + (0.125\text{ m})^{-3/5}]^{5/3}} = 0.0095\text{ m}$$

Then

$$Ra_c = \frac{g\beta(T_s - T_\infty)L_c^3}{\nu\alpha} = \frac{9.8\text{ m/s}^2 \times (1/350\text{ K}) (400 - 300)\text{K} (0.0095\text{ m})^3}{4.155 \times 10^{-6}\text{ m}^2/\text{s} \times 5.842 \times 10^{-6}\text{ m}^2/\text{s}} = 98,800$$

The effective thermal conductivity is found from Eq. 9.59,

$$\frac{k_{\text{eff}}}{k} = 0.386 \left( \frac{Pr}{0.861 + Pr} \right)^{1/4} Ra_c^{1/4}$$

$$\frac{k_{\text{eff}}}{k} = 0.386 \left( \frac{0.711}{0.861 + 0.711} \right)^{1/4} (98,800)^{1/4} = 5.61.$$

Hence, the heat rate, Eq. (1), becomes

$$q' = \frac{2\pi \times 5.61 \times 0.0293\text{ W/m}\cdot\text{K}}{\ln(125/100)} (400 - 300)\text{K} = 463\text{ W/m}. \quad <$$

**COMMENTS:** Note that the heat loss by convection is nearly six times that for conduction. Radiation transfer is likely to be important for this situation. The effect of nitrogen pressure is to decrease  $\nu$  which in turn increases  $Ra_L$ ; that is, free convection heat transfer will increase with increase in pressure.

### PROBLEM 9.106

**KNOWN:** Diameter of cylindrical enclosure housing solid PCM. Diameter and temperature of heated inner concentric cylinder. Initial PCM temperature.

**FIND:** Time to melt half of PCM.

**SCHEMATIC:**

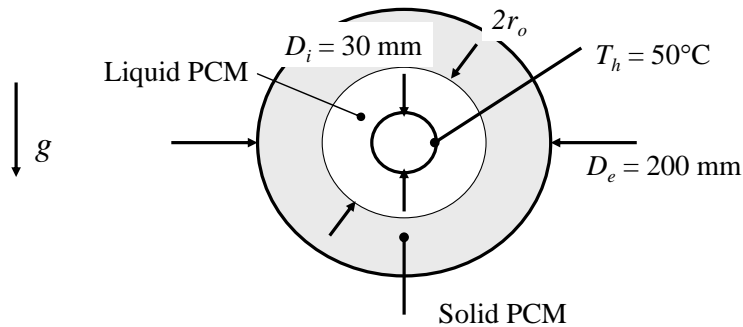

**ASSUMPTIONS:** (1) The quasi-steady approximation holds: the heat transfer coefficient can be evaluated based on steady-state conditions, (2) Constant properties, (3) The sensible energy associated with the portion of PCM above its melting temperature is negligible.

**PROPERTIES:** From Problems 8.47 and 9.57, PCM:  $T_m = 27.4^\circ\text{C}$ ,  $h_{sf} = 244 \text{ kJ/kg}$ ,  $\rho = 770 \text{ kg/m}^3$ ,  $k = 0.15 \text{ W/m} \cdot \text{K}$ ,  $\beta = 8 \times 10^{-4} \text{ K}^{-1}$ ,  $\nu = 5 \times 10^{-6} \text{ m}^2/\text{s}$ ,  $\alpha = 8.85 \times 10^{-8} \text{ m}^2/\text{s}$ ,  $Pr = \nu/\alpha = 56.5$ ,  $c_p = k/\rho\alpha = 2200 \text{ J/kg} \cdot \text{K}$ .

**ANALYSIS:** The molten PCM occupies the region between the heater radius,  $r_i$ , and the solid-liquid interface,  $r_o$ . The latter radius is a function of time. According to the quasi-steady approximation, the convection heat transfer rate can be found from Eqs. 9.58, 9.59, and 9.60 using the instantaneous value of  $r_o$ . Combining these equations yields the convection heat transfer rate per unit length:

$$q' = 2\pi k(T_i - T_o)0.386 \left( \frac{Pr}{0.861 + Pr} \right)^{1/4} \left( \frac{g\beta(T_i - T_o)}{\nu\alpha} \right)^{1/4} \frac{2^{3/4}}{(r_i^{-3/5} + r_o^{-3/5})^{5/4}} = \frac{A}{(r_i^{-3/5} + r_o^{-3/5})^{5/4}} \quad (1)$$

where  $T_o = T_m = 27.4^\circ\text{C}$  and  $T_i = T_h = 50^\circ\text{C}$ . The constant  $A$  is defined by the above equation and has the value  $A = 1.10 \times 10^4 \text{ W/m}^{7/4}$ . The rate at which heat reaches the solid-liquid interface is equal to the rate of change of mass of molten PCM (kg/s) multiplied by the latent heat of fusion, thus

$$q' = \frac{dm'}{dt} h_{sf} = \frac{d}{dt} (\rho\pi(r_o^2 - r_i^2)) h_{sf} = 2\pi r_o \rho h_{sf} \frac{dr_o}{dt} \quad (2)$$

Combining Eqs. (1) and (2) yields a differential equation for  $r_o(t)$ :

$$\frac{dr_o}{dt} = \frac{A / 2\pi\rho h_{sf}}{r_o (r_i^{-3/5} + r_o^{-3/5})^{5/4}}$$

The criterion that half the PCM has been melted is satisfied when  $\pi(r_{o,\text{final}}^2 - r_i^2) = \frac{1}{2}\pi(r_e^2 - r_i^2)$ , where  $r_e = \frac{1}{2}D_e = 0.1 \text{ m}$ . Thus,  $r_{o,\text{final}} = \left[ \frac{1}{2}(r_e^2 + r_i^2) \right]^{1/2} = 0.0715 \text{ m}$ . The above differential equation is most easily solved numerically. It has been solved using IHT to generate the following graph.

Continued...

### PROBLEM 9.106 (Cont.)

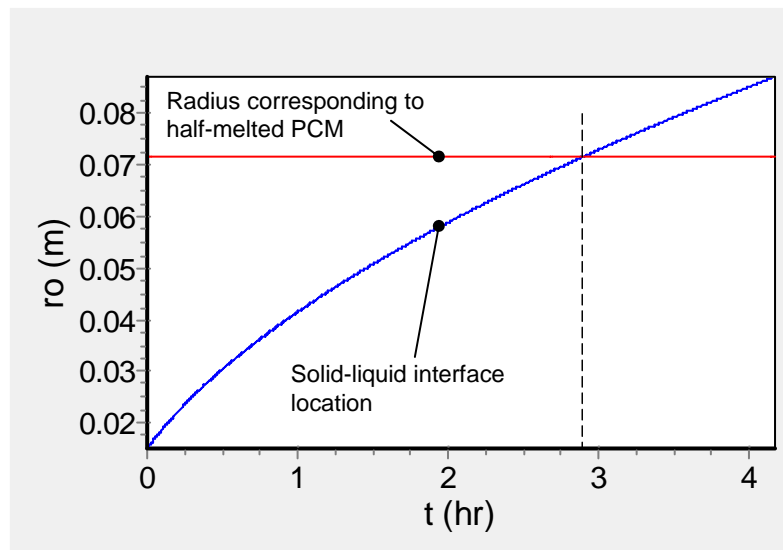

The final radius criterion,  $r_o = 0.0715$  m, is satisfied at  $t = 2.88$  h.

<

**COMMENTS:** (1) The solid-liquid interface moves slowly, traveling around 70 mm in 2.88 h. It is likely that the free convection motion can adjust to the instantaneous conditions relatively quickly compared with the rate at which the interface is moving. That is, the quasi-steady approximation is probably accurate. (2) The sensible energy associated with the portion of PCM above its melting temperature was neglected. The temperature of the molten PCM varies from the melting temperature to the heater temperature. We can estimate the average PCM temperature as  $(27.4+50)^\circ\text{C}/2 = 38.7^\circ\text{C}$ . The ratio of the sensible energy to the latent energy is  $mc_p(T - T_m)/mh_{sf} = c_p(T - T_m)/h_{sf}$ . This ratio is a dimensionless parameter known as the Stefan number,  $Ste$ . Here  $Ste = 0.10$ . Thus, the error associated with neglecting the sensible energy is on the order of 10%.

### PROBLEM 9.107

**KNOWN:** Diameters and temperatures of concentric spheres.

**FIND:** Rate at which stored nitrogen is vented.

**SCHEMATIC:**

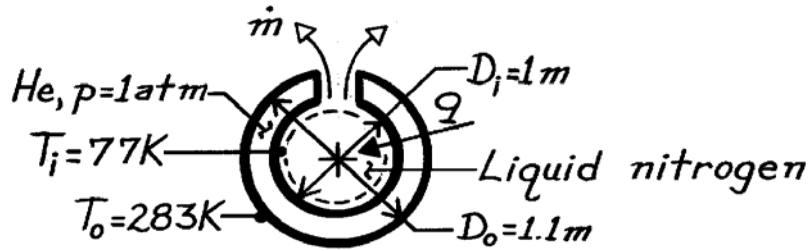

**ASSUMPTIONS:** (1) Negligible radiation.

**PROPERTIES:** Liquid nitrogen (given):  $h_{fg} = 2 \times 10^5 \text{ J/kg}$ ; Table A-4, Helium ( $\bar{T} = (T_i + T_o)/2 = 180\text{K}$ , 1 atm):  $\nu = 51.3 \times 10^{-6} \text{ m}^2/\text{s}$ ,  $k = 0.107 \text{ W/m}\cdot\text{K}$ ,  $\alpha = 76.2 \times 10^{-6} \text{ m}^2/\text{s}$ ,  $\text{Pr} = 0.673$ ,  $\beta = 0.00556 \text{ K}^{-1}$ .

**ANALYSIS:** Performing an energy balance for a control surface about the liquid nitrogen, it follows that

$$q = q_{\text{conv}} = \dot{m} h_{fg}$$

From the Raithby and Hollands expressions for free convection between concentric spheres,

$$q_{\text{conv}} = \frac{4\pi k_{\text{eff}} (T_i - T_o)}{(1/r_i) - (1/r_o)}$$

$$k_{\text{eff}} = 0.74k \left[ \text{Pr} / (0.861 + \text{Pr}) \right]^{1/4} \left( \text{Ra}_s \right)^{1/4}$$

where  $L_s = \frac{(1/r_i - 1/r_o)^{4/3}}{2^{1/3} (r_i^{-7/5} + r_o^{-7/5})^{5/3}} = 5.69 \times 10^{-3} \text{ m}$

$$\text{Ra}_s = \frac{g\beta(T_o - T_i)L_s^3}{\nu\alpha} = \frac{9.8 \text{ m/s}^2 (0.00556 \text{ K}^{-1})(206 \text{ K})(5.69 \times 10^{-3} \text{ m})^3}{(51.3 \times 10^{-6} \text{ m}^2/\text{s})(76.2 \times 10^{-6} \text{ m}^2/\text{s})} = 528$$

$$k_{\text{eff}} = 0.74(0.107 \text{ W/m}\cdot\text{K}) \left[ 0.673 / (0.861 + 0.673) \right]^{1/4} (528)^{1/4} = 0.309 \text{ W/m}\cdot\text{K}$$

Hence,  $q_{\text{conv}} = \frac{(0.309 \text{ W/m}\cdot\text{K}) \times 4\pi (206 \text{ K})}{(1/0.5 \text{ m}) - (1/0.55 \text{ m})} = 4399 \text{ W}$

The rate at which nitrogen is lost from the system is therefore

$$\dot{m} = q_{\text{conv}} / h_{fg} = 4399 \text{ W} / 2 \times 10^5 \text{ J/kg} = 0.022 \text{ kg/s}$$

<

**COMMENTS:** The heat gain and mass loss are large. Helium should be replaced by a noncondensing gas of smaller  $k$ , or the cavity should be evacuated.

## PROBLEM 9.108

**KNOWN:** Dimensions of enclosure, surface temperatures, and properties of aqueous humor.

**FIND:** The ratio of the effective to the bulk thermal conductivity of the aqueous humor.

**SCHEMATIC:**

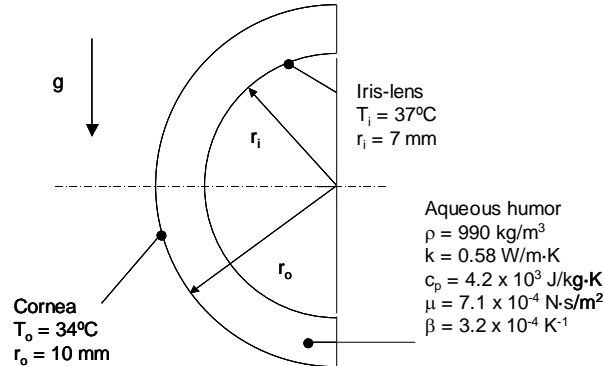

**ASSUMPTIONS:** (1) Constant properties, (2) Steady-state conditions, (3) Person is standing or sitting vertically.

**PROPERTIES:** Given, see schematic.

**ANALYSIS:** The kinematic viscosity is  $\nu = \mu/\rho = 7.1 \times 10^{-4} \text{ N}\cdot\text{s}/\text{m}^2/990 \text{ kg}/\text{m}^3 = 7.17 \times 10^{-9} \text{ m}^2/\text{s}$ . The thermal diffusivity is  $\alpha = k/\rho c_p = 0.58 \text{ W}/\text{m}\cdot\text{K}/(990 \text{ kg}/\text{m}^3 \times 4.2 \times 10^3 \text{ J}/\text{kg}\cdot\text{K}) = 139.5 \times 10^{-4} \text{ m}^2/\text{s}$ , while the Prandtl number is  $\text{Pr} = \nu/\alpha = (7.17 \times 10^{-9} \text{ m}^2/\text{s})/(139.5 \times 10^{-4} \text{ m}^2/\text{s}) = 5.14$ . The characteristic length for use in Equation 9.61 is

$$L_s = \frac{\left(\frac{1}{r_i} - \frac{1}{r_o}\right)^{4/3}}{2^{1/3} \left(r_i^{-7/5} + r_o^{-7/5}\right)^{5/3}} = \frac{\left(\frac{1}{7 \times 10^{-3} \text{ m}} - \frac{1}{10 \times 10^{-3} \text{ m}}\right)^{4/3}}{2^{1/3} \left((7 \times 10^{-3} \text{ m})^{-7/5} + (10 \times 10^{-3} \text{ m})^{-7/5}\right)^{5/3}} = 506 \times 10^{-6} \text{ m}$$

The Rayleigh number is

$$\text{Ra}_s = \frac{g\beta(T_s - T_o)L_s^3}{\nu \cdot \alpha} = \frac{9.8 \text{ m}/\text{s}^2 \times 3.2 \times 10^{-4} \text{ K}^{-1} \times (37 - 34)^\circ\text{C} \times (506 \times 10^{-6} \text{ m})^3}{7.17 \times 10^{-9} \text{ m}^2/\text{s} \times 139.5 \times 10^{-4} \text{ m}^2/\text{s}} = 12.2$$

The ratio of the effective thermal conductivity to bulk thermal conductivity is

$$\frac{k_{\text{eff}}}{k} = 0.74 \left(\frac{\text{Pr}}{0.861 + \text{Pr}}\right)^{1/4} \text{Ra}_s^{1/4} = 0.74 \times \left(\frac{5.14}{0.861 + 5.14}\right)^{1/4} \times (12.2)^{1/4} = 1.33 <$$

Since  $k_{\text{eff}}/k > 1$ , we conclude that free convection does occur in the aqueous humor.

**Comments:** (1). The velocity of the aqueous humor could be estimated by performing a detailed simulation using a CFD (computational fluid dynamics) tool. (2) Fluid motion is upward near the iris and downward adjacent to the cornea when the person is standing or sitting vertically.

### PROBLEM 9.109

**KNOWN:** Diameter and temperature of cylinder. Velocity and temperature of fluid in cross flow. Four different fluids.

**FIND:** Whether heat transfer by free convection is significant.

**SCHEMATIC:**

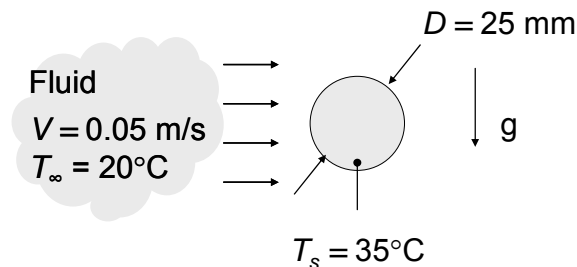

**ASSUMPTIONS:** (1) Steady state, (2) Constant properties, (3) Air can be modeled as an ideal gas.

**PROPERTIES:** Air (300K, 1 atm):  $\beta = 1/T_f = 3.333 \times 10^{-3} \text{ K}^{-1}$ ; Table A-6, Water ( $T_f = (T_\infty + T_s)/2 = 300\text{K}$ ):  $\beta = 276.1 \times 10^{-6} \text{ K}^{-1}$ ; Table A-5, Engine oil ( $T_f = (T_\infty + T_s)/2 = 300\text{K}$ ):  $\beta = 0.7 \times 10^{-3} \text{ K}^{-1}$ ; Table A-5, Mercury ( $T_f = (T_\infty + T_s)/2 = 300\text{K}$ ):  $\beta = 0.181 \times 10^{-3} \text{ K}^{-1}$ .

**ANALYSIS:** Following the discussion of Section 9.9, the general criterion for delineating the relative significance of free and forced convection depends upon the value of  $Gr/Re^2$ . Free convection is insignificant if  $Gr/Re^2 \ll 1$ , where  $Gr = g\beta(T_s - T_\infty)D^3/\nu^2$  and  $Re = VD/\nu$ . Thus,

$$Gr / Re^2 = g\beta(T_s - T_\infty)D / V^2$$

The only material property that impacts the determination of the significance of free convection is the thermal expansion coefficient,  $\beta$ . Furthermore with all other parameters held fixed, it is useful to express  $Gr/Re^2 = G\beta$ , where

$$G = g(T_s - T_\infty)D/V^2 = 9.8 \text{ m/s}^2 \times (35 - 20)^\circ\text{C} \times 0.025 \text{ m}/(0.05 \text{ m/s})^2 = 1470 \text{ K}$$

Thus, for air,

$$Gr/Re^2 = G\beta = 1470 \text{ K} \times 3.333 \times 10^{-3} \text{ K}^{-1} = 4.90$$

Since  $Gr/Re^2 > 1$ , free convection is significant. <

For water,

$$Gr/Re^2 = G\beta = 1470 \text{ K} \times 276.1 \times 10^{-6} \text{ K}^{-1} = 0.406$$

Since  $Gr/Re^2$  is not small compared to 1, free convection is likely to be important. <

Continued...

### PROBLEM 9.109 (Cont.)

For engine oil,

$$Gr/Re^2 = G\beta = 1470 \text{ K} \times 0.7 \times 10^{-3} \text{ K}^{-1} = 1.03$$

Since  $Gr/Re^2$  is of order 1, free and forced convection are likely to be equally important. <

For mercury,

$$Gr/Re^2 = G\beta = 1470 \text{ K} \times 0.181 \times 10^{-3} \text{ K}^{-1} = 0.266$$

Since  $Gr/Re^2$  is somewhat small compared to 1, free convection might be negligible, depending on the desired accuracy of the solution. <

**COMMENTS:** (1) None of the situations considered here correspond to conditions where heat transfer is clearly dominated by either natural or forced convection. In such situations, it may be necessary to determine the convection heat transfer rates experimentally, or by solving the three-dimensional, unsteady forms of the convection transfer equations computationally. (2)  $Gr/Re^2$  is sometimes referred to as the Richardson number,  $Ri$ .



### PROBLEM 9.110

**KNOWN:** Parallel air flow over a uniform temperature, heated vertical plate; the effect of free convection on the heat transfer coefficient will be 5% when  $Gr_L / Re_L^2 = 0.08$ .

**FIND:** Minimum vertical velocity required of air flow such that free convection effects will be less than 5% of the heat rate.

**SCHEMATIC:**

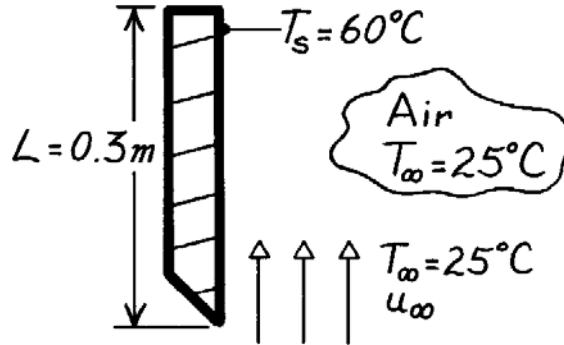

**ASSUMPTIONS:** (1) Steady-state conditions, (2) Criterion for combined free-forced convection determined from experimental results.

**PROPERTIES:** Table A-4, Air ( $T_f = (T_s + T_\infty)/2 = 315\text{K}$ , 1 atm):  $\nu = 17.40 \times 10^{-6} \text{ m}^2/\text{s}$ ,  $\beta = 1/T_f$ .

**ANALYSIS:** To delineate flow regimes, according to Section 9.9, the general criterion for predominately forced convection is that

$$Gr_L / Re_L^2 \ll 1. \quad (1)$$

From experimental results, when  $Gr_L / Re_L^2 \approx 0.08$ , free convection will be equal to 5% of the total heat rate.

For the vertical plate using Eq. 9.12,

$$Gr_L = \frac{g \beta (T_1 - T_2) L^3}{\nu^2} = \frac{9.8 \text{ m/s}^2 \times 1/315\text{K} \times (60 - 25)\text{K} \times (0.3\text{m})^3}{(17.40 \times 10^{-6} \text{ m}^2/\text{s})^2} = 9.711 \times 10^7. \quad (2)$$

For the vertical plate with forced convection,

$$Re_L = \frac{u_\infty L}{\nu} = \frac{u_\infty (0.3\text{m})}{17.4 \times 10^{-6} \text{ m}^2/\text{s}} = 1.724 \times 10^4 u_\infty. \quad (3)$$

By combining Eqs. (2) and (3),

$$\frac{Gr_L}{Re_L^2} = \frac{9.711 \times 10^7}{[1.724 \times 10^4 u_\infty]^2} = 0.08$$

find that

$$u_\infty = 2.02 \text{ m/s}. \quad <$$

That is, when  $u_\infty \geq 2.02 \text{ m/s}$ , free convection effects will not exceed 5% of the total heat rate.

### PROBLEM 9.111

**KNOWN:** Vertical array of circuit boards 0.15m high with maximum allowable uniform surface temperature for prescribed ambient air temperature.

**FIND:** Allowable electrical power dissipation per board,  $q'$  [W/m], for these cooling arrangements:

(a) Free convection only, (b) Air flow downward at 0.6 m/s, (c) Air flow upward at 0.3 m/s, and (d) Air flow upward or downward at 5 m/s.

**SCHEMATIC:**

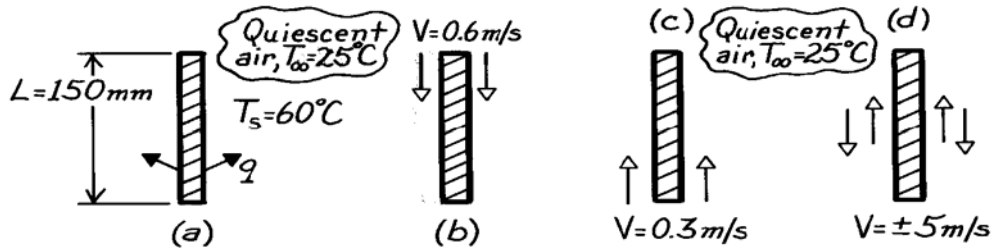

**ASSUMPTIONS:** (1) Uniform surface temperature, (2) Board horizontal spacing sufficient that boundary layers don't interfere, (3) Ambient air behaves as quiescent medium, (4) Perfect gas behavior.

**PROPERTIES:** Table A-4, Air ( $T_f = (T_s + T_\infty)/2 \approx 315\text{K}$ , 1 atm):  $\nu = 17.40 \times 10^{-6} \text{ m}^2/\text{s}$ ,  $k = 0.0274 \text{ W/m}\cdot\text{K}$ ,  $\alpha = 24.7 \times 10^{-6} \text{ m}^2/\text{s}$ ,  $\text{Pr} = 0.705$ ,  $\beta = 1/T_f$ .

**ANALYSIS:** (a) For *free convection* only, the allowable electrical power dissipation rate is

$$q' = \bar{h}_L (2L)(T_s - T_\infty) \quad (1)$$

where  $\bar{h}_L$  is estimated using the appropriate correlation for free convection from a vertical plate. Find the Rayleigh number,

$$\text{Ra}_L = \frac{g \beta \Delta T L^3}{\nu \alpha} = \frac{9.8 \text{ m/s}^2 (1/315\text{K})(60 - 25)\text{K} (0.150\text{m})^3}{17.4 \times 10^{-6} \text{ m}^2/\text{s} \times 24.7 \times 10^{-6} \text{ m}^2/\text{s}} = 8.551 \times 10^6. \quad (2)$$

Since  $\text{Ra}_L < 10^9$ , the flow is laminar. With Eq. 9.27 find

$$\bar{\text{Nu}}_L = \frac{\bar{h}_L}{k} = 0.68 + \frac{0.670 \text{ Ra}_L^{1/4}}{\left[1 + (0.492/\text{Pr})^{9/16}\right]^{4/9}} = 0.68 + \frac{\left(0.670 \left[8.551 \times 10^6\right]^{1/4}\right)}{\left[1 + (0.492/0.705)^{9/16}\right]^{4/9}} = 28.47 \quad (3)$$

$$\bar{h}_L = (0.0274 \text{ W/m}\cdot\text{K} / 0.150\text{m}) \times 28.47 = 5.20 \text{ W/m}^2 \cdot \text{K}.$$

Hence, the allowable electrical power dissipation rate is,

$$q' = 5.20 \text{ W/m}^2 \cdot \text{K} (2 \times 0.150\text{m})(60 - 25)^\circ\text{C} = 54.6 \text{ W/m}. \quad \leftarrow$$

(b) With *downward velocity*  $V = 0.6 \text{ m/s}$ , the possibility of mixed forced-free convection must be considered. With  $\text{Re}_L = VL/\nu$ , find

$$\left(\text{Gr}_L / \text{Re}_L^2\right) = \left(\frac{\text{Ra}_L}{\text{Pr}} / \text{Re}_L^2\right) \quad (4)$$

$$\left(\text{Gr}_L / \text{Re}_L^2\right) = \left(8.551 \times 10^6 / 0.705\right) / \left(0.6 \text{ m/s} \times 0.150\text{m} / 17.40 \times 10^{-6} \text{ m}^2/\text{s}\right)^2 = 0.453.$$

Continued ...

**PROBLEM 9.111 (Cont.)**

Since  $(Gr_L / Re_L^2) \sim 1$ , flow is mixed and the average heat transfer coefficient may be found from a correlating equation of the form

$$\overline{Nu}^n = Nu_F^n \pm Nu_N^n \quad (5)$$

where  $n = 3$  for the vertical plate geometry and the minus sign is appropriate since the natural convection (N) flow opposes the forced convection (F) flow. For the forced convection flow,  $Re_L = 5172$  and the flow is laminar; using Eq. 7.30,

$$\overline{Nu}_F = 0.664 Re_L^{1/2} Pr^{1/3} = 0.664(5172)^{1/2} (0.705)^{1/3} = 42.50. \quad (6)$$

Using  $\overline{Nu}_N = 28.47$  from Eq. (3), Eq. (5) now becomes

$$\overline{Nu}^3 = \left( \frac{\overline{h}L}{k} \right)^3 = (42.50)^3 - (28.47)^3 \quad \overline{Nu} = 37.72$$

$$\overline{h} = \left( \frac{0.0274 \text{ W/m} \cdot \text{K}}{0.150 \text{ m}} \right) \times 37.72 = 6.89 \text{ W/m}^2 \cdot \text{K}.$$

Substituting for  $\overline{h}$  into the rate equation, Eq. (1), the allowable power dissipation with a downward velocity of 0.6 m/s is

$$q' = 6.89 \text{ W/m}^2 \cdot \text{K} (2 \times 0.150 \text{ m}) (60 - 25)^\circ\text{C} = 72.3 \text{ W/m}. \quad <$$

(c) With an *upward velocity*  $V = 0.3$  m/s, the positive sign of Eq. (5) applies since the N-flow is assisting the F-flow. For forced convection, find

$$Re_L = VL/\nu = 0.3 \text{ m/s} \times 0.150 \text{ m} / (17.40 \times 10^{-6} \text{ m}^2/\text{s}) = 2586.$$

The flow is again laminar, hence Eq. (6) is appropriate.

$$\overline{Nu}_F = 0.664(2586)^{1/2} (0.705)^{1/3} = 30.05.$$

From Eq. (5), with the positive sign, and  $\overline{Nu}_N$  from Eq. (4),

$$\overline{Nu}^3 = (30.05)^3 + (28.47)^3 \quad \text{or} \quad \overline{Nu} = 36.88 \quad \text{and} \quad \overline{h} = 6.74 \text{ W/m}^2 \cdot \text{K}.$$

From Eq. (1), the allowable power dissipation with an upward velocity of 0.3 m/s is

$$q' = 6.74 \text{ W/m}^2 \cdot \text{K} (2 \times 0.150 \text{ m}) (60 - 25)^\circ\text{C} = 70.7 \text{ W/m}. \quad <$$

(d) With a *forced convection* velocity  $V = 5$  m/s, very likely forced convection will dominate. Check by evaluating whether  $(Gr_L / Re_L^2) \ll 1$  where  $Re_L = VL/\nu = 5 \text{ m/s} \times 0.150 \text{ m} / (17.40 \times 10^{-6} \text{ m}^2/\text{s}) = 43,103$ . Hence,

$$\left( Gr_L / Re_L^2 \right) = \left( \frac{Ra_L}{Pr} / Re_L^2 \right) = (8.551 \times 10^6 / 0.705) / 43,103^2 = 0.007.$$

The flow is not mixed, but pure forced convection. Using Eq. (6), find

$$\overline{h} = (0.0274 \text{ W/m} \cdot \text{K} / 0.150 \text{ m}) 0.664(43,103)^{1/2} (0.705)^{1/3} = 22.4 \text{ W/m}^2 \cdot \text{K}$$

and the allowable dissipation rate is

$$q' = 22.4 \text{ W/m}^2 \cdot \text{K} (2 \times 0.150 \text{ m}) (60 - 25)^\circ\text{C} = 235 \text{ W/m}. \quad <$$

**COMMENTS:** Be sure to compare dissipation rates to see relative importance of mixed flow conditions.

## PROBLEM 9.112

**KNOWN:** Dimensions of horizontal tube in wind tunnel. Air velocity and temperature, surroundings temperature, emissivity of tube surface, power dissipation.

**FIND:** (a) Tube surface temperature for  $T_\infty = 25^\circ\text{C}$ ,  $V = 0.1 \text{ m/s}$ , (b) Plot of the tube surface temperature versus the cross flow velocity for  $0.05 \text{ m/s} \leq V \leq 1 \text{ m/s}$ .

**SCHEMATIC:**

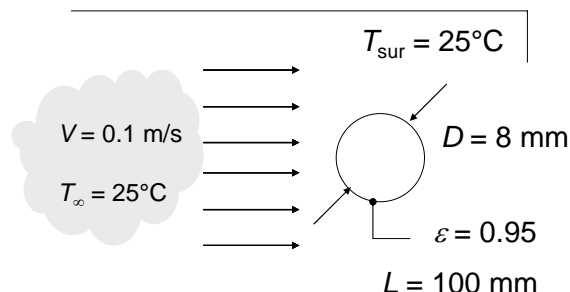

**ASSUMPTIONS:** (1) Constant properties, (2) Large surroundings, (3) Steady-state conditions, (4) Ideal gas.

**PROPERTIES:** Table A.4, air ( $T_f \approx 300 \text{ K}$ ):  $\nu = 15.89 \times 10^{-6} \text{ m}^2/\text{s}$ ,  $k = 0.0263 \text{ W/m}\cdot\text{K}$ ,  $\alpha = 22.5 \times 10^{-6} \text{ m}^2/\text{s}$ ,  $Pr = 0.707$ ,  $\beta = 1/T_f = 0.0033 \text{ K}^{-1}$ .

**ANALYSIS:** (a) An energy balance on the cylinder yields

$$\begin{aligned}
 P = 1.5 \text{ W} &= q_{\text{conv}} + q_{\text{rad}} = \pi DL \left[ \bar{h}(T_s - T_\infty) + \varepsilon \sigma (T_s^4 - T_{\text{sur}}^4) \right] \\
 &= \pi 0.008 \text{ m} \times 0.10 \text{ m} \left[ \bar{h}(T_s - (25 + 273) \text{ K}) + 0.95 \times 5.67 \times 10^{-8} \text{ W/m}^2 \cdot \text{K}^4 (T_s^4 - (25 + 273 \text{ K})^4) \right]
 \end{aligned} \tag{1}$$

From Equation 9.64 for mixed convection from a cylinder in transverse flows,

$$\overline{Nu}_D^4 = \overline{Nu}_{D,F}^4 + \overline{Nu}_{D,N}^4 \tag{2}$$

where the forced convection Nusselt number,  $\overline{Nu}_{D,F}$ , is provided by the Churchill and Bernstein correlation of Chapter 7, and  $Re_D = VD/\nu = (0.1 \text{ m/s} \times 0.008 \text{ m})/15.89 \times 10^{-6} \text{ m}^2/\text{s} = 50.35$ .

$$\begin{aligned}
 \overline{Nu}_{D,F} &= 0.3 + \frac{0.62 Re_D^{1/2} Pr^{1/3}}{\left[ 1 + (0.4/Pr)^{2/3} \right]^{1/4}} \left[ 1 + \left( \frac{Re_D}{282,000} \right)^{5/8} \right]^{4/5} \\
 &= 0.3 + \frac{0.62 \times 50.35^{1/2} \times 0.707^{1/3}}{\left[ 1 + (0.4/0.707)^{2/3} \right]^{1/4}} \left[ 1 + \left( \frac{50.35}{282,000} \right)^{5/8} \right]^{4/5} = 3.75
 \end{aligned} \tag{3}$$

The natural (free) convection Nusselt number,  $\overline{Nu}_{D,N}$ , is found from the Churchill and Chu correlation,

Continued...

**PROBLEM 9.112 (Cont.)**

$$\overline{Nu}_{D,N} = \left\{ 0.60 + \frac{0.387 Ra_D^{1/6}}{\left[ 1 + (0.559 / Pr)^{9/16} \right]^{8/27}} \right\}^2 \quad (4a)$$

where the Rayleigh number is,

$$Ra_D = \frac{g\beta(T_s - T_\infty)D^3}{\nu\alpha} = \frac{9.8 \text{ m/s}^2 \times (0.0033 \text{ K}^{-1}) \times (T_s - (25 + 273) \text{ K}) \times (0.008 \text{ m})^3}{15.89 \text{ m}^2/\text{s} \times 22.5 \times 10^{-12} \text{ m}^2/\text{s}} \quad (4b)$$

Finally,  $\bar{h} = \overline{Nu}_D k / D$  (5)

Simultaneous solution of Equations (1) through (5) yields  $T_s = 328.1 \text{ K} = 55.1^\circ\text{C}$  <

(b) The dependence of the surface temperature on the air velocity is shown below.

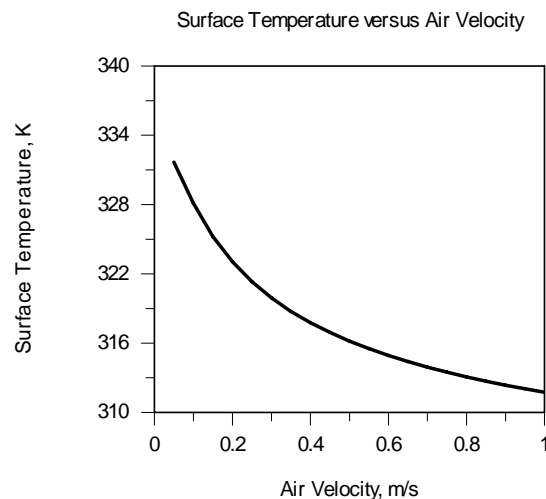

**COMMENTS:** (1) In part (a), the convective and radiative heat rates are  $q_{\text{conv}} = 1 \text{ W}$  and  $q_{\text{rad}} = 0.5 \text{ W}$ , respectively. Therefore, it is important to include radiative losses in the analysis, (2) If free convection is ignored in part (a), the predicted surface temperature is  $T_s = 329.4 \text{ K}$ . Alternatively, if the forced convection component is ignored,  $T_s = 334.3 \text{ K}$ , (3) The surface temperature is strongly dependent on the air velocity, as evident in the solution to part (b). Using modern infrared detectors, the resolution of the surface temperature measurement could be as small as  $\Delta T = 0.05 \text{ K}$ . Hence, the measured surface temperature could be used to determine the air velocity.

### PROBLEM 9.113

**KNOWN:** Horizontal pipe passing hot oil used to heat water.

**FIND:** Effect of water flow direction on the heat rate.

**SCHEMATIC:**

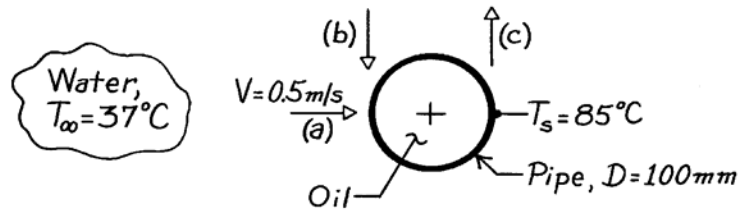

**ASSUMPTIONS:** (1) Uniform pipe surface temperature, (2) Constant properties.

**PROPERTIES:** Table A-6, Water ( $T_f = (T_s + T_\infty)/2 \approx 335\text{K}$ ):  $\nu = \mu_f \nu_f = 4.625 \times 10^{-7} \text{ m}^2/\text{s}$ ,  $k = 0.656 \text{ W/m}\cdot\text{K}$ ,  $\alpha = k \nu_f / c_p = 1.595 \times 10^{-7} \text{ m}^2/\text{s}$ ,  $\text{Pr} = 2.88$ ,  $\beta = 535.5 \times 10^{-6} \text{ K}^{-1}$ ; Table A-6, Water ( $T_\infty = 310\text{K}$ ):  $\nu = \mu_f \nu_f = 6.999 \times 10^{-7} \text{ m}^2/\text{s}$ ,  $k = 0.028 \text{ W/m}\cdot\text{K}$ ,  $\text{Pr} = 4.62$ ; Table A-6, Water ( $T_s = 358\text{K}$ ):  $\text{Pr} = 2.07$

**ANALYSIS:** The rate equation for the flow situations is of the form

$$q' = \bar{h} (\pi D) (T_s - T_\infty).$$

To determine whether mixed flow conditions are present, evaluate  $(\text{Gr}_D / \text{Re}_D^2)$ .

$$\text{Gr}_D = \frac{g \beta \Delta T D^3}{\nu^2} = \frac{9.8 \text{ m/s}^2 \times 535.5 \times 10^{-6} \text{ K}^{-1} (85 - 37) \text{ K} (0.100 \text{ m})^3}{(4.625 \times 10^{-7} \text{ m}^2/\text{s})^2} = 1.178 \times 10^9$$

$$\text{Re}_D = VD / \nu = 0.5 \text{ m/s} \times 0.100 \text{ m} / 6.999 \times 10^{-7} \text{ m}^2/\text{s} = 7.144 \times 10^4.$$

It follows that  $(\text{Gr}_D / \text{Re}_D^2) = 0.231$ ; since this ratio is of order unity, the flow condition is mixed. Using

Eq. 9.64,  $\overline{\text{Nu}}^n = \overline{\text{Nu}}_F^n \pm \overline{\text{Nu}}_N^n$  and for the three flow arrangements,

(a) Transverse flow:	(b) Opposing flow:	(c) Assisting flow:
$\overline{\text{Nu}}^4 = \overline{\text{Nu}}_F^4 + \overline{\text{Nu}}_N^4$	$\overline{\text{Nu}}^3 = \overline{\text{Nu}}_F^3 - \overline{\text{Nu}}_N^3$	$\overline{\text{Nu}}^3 = \overline{\text{Nu}}_F^3 + \overline{\text{Nu}}_N^3$

For *natural convection* from the cylinder, use Eq. 9.34 with  $\text{Ra} = \text{Gr} \cdot \text{Pr}$ .

$$\overline{\text{Nu}}_N = \left\{ 0.60 + \frac{0.387 \text{ Ra}_D^{1/6}}{\left[ 1 + (0.559 / \text{Pr})^{9/16} \right]^{8/27}} \right\}^2 = \left\{ 0.60 + \frac{0.387 \left( 1.178 \times 10^9 \times 2.88 \right)^{1/6}}{\left[ 1 + (0.559 / 2.88)^{9/16} \right]^{8/27}} \right\}^2 = 201.2$$

For *forced convection* in cross flow over the cylinder, from Table 7-4 use

$$\overline{\text{Nu}}_F = C \text{ Re}_D^m \text{ Pr}^n (\text{Pr} / \text{Pr}_s)^{1/4}$$

$$\overline{\text{Nu}}_F = 0.26 \left( 7.144 \times 10^4 \right)^{0.6} (4.62)^{0.37} (4.62 / 2.07)^{1/4} = 457.5$$

Continued ...

**PROBLEM 9.113 (Cont.)**

where  $n = 0.37$  since  $Pr \leq 10$ . The results of the calculations are tabulated.

Flow	$\overline{Nu}$	$\overline{h} \left( W / m^2 \cdot K \right)$	$q' \times 10^{-4} \left( W / m \right)$
(a) Transverse	461.7	3029	4.57
(b) Opposing	444.1	2913	4.39
(c) Assisting	470.1	3083	4.65

**COMMENTS:** Note that the flow direction has a minor effect (<6%) for these conditions.

## PROBLEM 9.114

**KNOWN:** Plate dimensions and initial temperature. Velocity and temperature of air in parallel flow over plates.

**FIND:** Initial rate of heat transfer from plate. Initial rate of change of plate temperature. Graph of the free, forced and mixed convection heat transfer coefficients over the range  $2 \leq u_\infty \leq 10$  m/s.

**SCHEMATIC:**

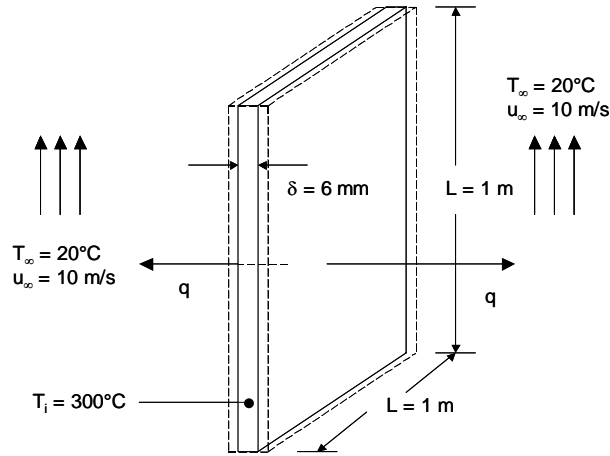

**ASSUMPTIONS:** (1) Negligible radiation, (2) Negligible effect of conveyor velocity on boundary layer development, (3) Lumped capacitance behavior, (4) Negligible heat transfer from sides of plate.

**PROPERTIES:** Table A.1, AISI 1010 steel ( $T = 573$  K):  $k_p = 49.2$  W/m·K,  $c = 549$  J/kg·K,  $\rho = 7832$  kg/m<sup>3</sup>. Table A.4, air: ( $p = 1$  atm,  $T_f = 433$  K):  $k = 0.0361$  W/m·K,  $\nu = 30.4 \times 10^{-6}$  m<sup>2</sup>/s,  $\alpha = 4.417 \times 10^{-5}$  m<sup>2</sup>/s,  $\text{Pr} = 0.688$ .

**ANALYSIS:** The initial rate of heat transfer from the plate is

$$q_i = 2\bar{h}A_s(T_i - T_\infty) = 2\bar{h}L(T_i - T_\infty)$$

With  $\text{Re}_L = u_\infty L / \nu = 10 \text{ m/s} \times 1 \text{ m} / 30.4 \times 10^{-6} \text{ m}^2/\text{s} = 3.29 \times 10^5$ , the forced convection is laminar. Therefore,  $\bar{\text{Nu}}_L = \text{Nu}_F = 0.664 \text{Re}_L^{1/2} \text{Pr}^{1/3} = 0.664 \times (3.29 \times 10^5)^{1/2} \times (0.688)^{1/3} = 336$ . With  $\text{Ra}_L = g\beta(T_i - T_\infty)L^3 / \nu\alpha = 9.8 \text{ m/s}^2 \times (1/433 \text{ K}) \times (300 - 20)^\circ\text{C} \times (1 \text{ m})^3 / (30.4 \times 10^{-6} \text{ m}^2/\text{s} \times 4.417 \times 10^{-5} \text{ m}^2/\text{s}) = 4.72 \times 10^9$ , The Churchill and Chu correlation yields

$$\bar{\text{Nu}}_L = \text{Nu}_N = \left\{ 0.825 + \frac{0.387\text{Ra}^{1/6}}{\left[1 + (0.492/\text{Pr})^{9/16}\right]^{8/27}} \right\}^2 = \left\{ 0.825 + \frac{0.387(4.72 \times 10^9)^{1/6}}{\left[1 + (0.492/0.688)^{9/16}\right]^{8/27}} \right\}^2 = 198$$

Continued...



### PROBLEM 9.114 (Cont.)

Since the forced and free convection induced flows are transverse,  $Nu = (Nu_F^3 + Nu_N^3)^{1/3} = (336^3 + 198^3) = 357$ . Hence,  $\bar{h} = Nu k/L = 357 \times 0.0361 \text{ W/m} \cdot \text{K} / 1\text{m} = 12.9 \text{ W/m}^2 \cdot \text{K}$  and

$$q_i = 2 \times 12.9 \text{ W/m}^2 \cdot \text{K} \times (1\text{m})^2 \times (300 - 20)^\circ\text{C} = 7224 \text{ W} \quad <$$

Performing an energy balance at an instant in time for the plate,  $-\dot{E}_{\text{out}} = \dot{E}_{\text{st}}$ , we obtain

$$\rho \delta L^2 c \left. \frac{dT}{dt} \right|_i = -\bar{h} 2L^2 (T_i - T_\infty)$$

or

$$\left. \frac{dT}{dt} \right|_i = \frac{2 \times 12.9 \text{ W/m}^2 \cdot \text{K} \times (300 - 20)^\circ\text{C}}{7832 \text{ kg/m}^3 \times 0.006 \text{ m} \times 549 \text{ J/kg} \cdot \text{K}} = -0.28^\circ\text{C/s} \quad <$$

The heat transfer coefficient may be evaluated over the velocity range  $2 \leq u_\infty \leq 10$  /ms, yielding

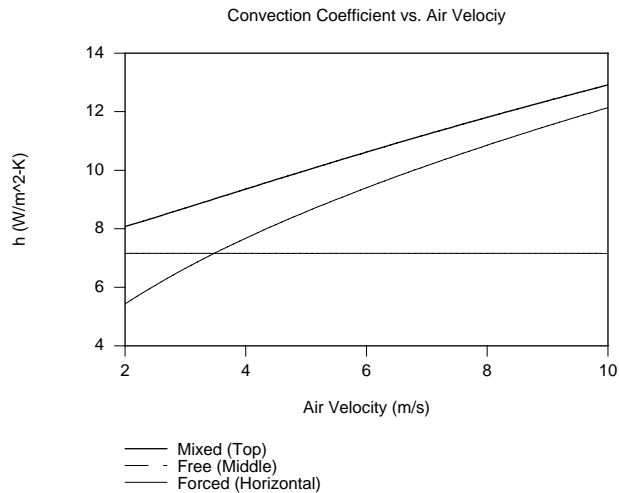

**COMMENTS:** (1) The Grashof number is  $Gr_L = Ra_L/Pr = 4.72 \times 10^9/0.688 = 6.86 \times 10^9$ . For the  $u_\infty = 10$  m/s case,  $Gr_L/Re_L^2 = 6.86 \times 10^9/(3.29 \times 10^5)^2 = 0.063 \ll 1$ . We therefore expect free convection effects to be minor. (2) At  $u_\infty \approx 3.5$  m/s the value of the free convection coefficient exceeds that of the forced convection coefficient. Free convection effects dominate at lower air forced velocities. (3) The Reynolds number,  $Re_L$ , is smaller than the transition Reynolds number ( $Re_{x,c} = 5 \times 10^5$ ) while the Rayleigh number,  $Ra_L$ , exceeds the value associated with transition to turbulent flow ( $Ra_{x,c} \approx 10^9$ ). This implies that flow conditions are very complex and the estimates of heat transfer rates are, at best, approximate. (4) At very low air forced velocities the plate motion will likely affect the boundary layer development. (5) The Biot number is  $Bi = \bar{h} \delta/k_p = 12.9 \text{ W/m}^2 \cdot \text{K} \times 0.006 \text{ m} / 49.2 \text{ W/m} \cdot \text{K} = 0.0016$  and the lumped capacitance approximation is valid.

## PROBLEM 9.115

**KNOWN:** Very small sphere.

**FIND:** Minimum value of the convection heat transfer coefficient expressed in terms of the sphere diameter and the thermal conductivity of air.

**SCHEMATIC:**

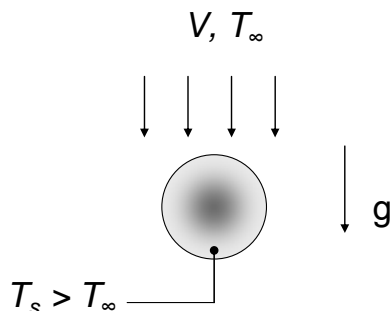

**ASSUMPTIONS:** Steady-state conditions.

**ANALYSIS:** According to Eq. 9.64, the Nusselt number for opposing flow is given by

$$Nu^n = Nu_F^n - Nu_N^n$$

The Nusselt number for pure forced convection past a sphere is given by Eq. 7.56. In the limit as  $D \rightarrow 0$ ,  $Re_D \rightarrow 0$ , and

$$Nu_F = 2$$

For pure free convection past a sphere, the Nusselt number is given by Eq. 9.35, and in the limit as  $D \rightarrow 0$ ,  $Ra_D \rightarrow 0$ , and

$$Nu_N = 2$$

Therefore, according to Eq. 9.64,

$$Nu^n = Nu_F^n - Nu_N^n = 0, \quad Nu = 0$$

Thus, Eq. 9.64 *implies* that convection heat losses could be entirely eliminated by incorporating the assistant's suggestion. However, this conclusion is flawed. The limiting values of Nusselt numbers for *both* the pure forced and pure free convection cases correspond to the conduction limit, that is, the limit of zero velocity everywhere. The best one could possibly achieve by superimposing a forced flow in opposition to free convection would be to eliminate the fluid motion. This condition would then correspond to heat loss from the sphere by pure conduction, yielding

$$Nu = 2 \text{ and } h = Nu(k/D) = 2k/D \quad <$$

**COMMENTS:** (1) It is not possible to completely eliminate heat losses, since heat transfer by conduction cannot be eliminated (except in a vacuum). (2) This exercise illustrates the approximate nature of Eq. 9.64, which is not correct in the limit of pure conduction. (3) In reality, it is not possible to completely eliminate motion at all points in the flow by superimposing a uniform downward flow on free convection.

### PROBLEM 9.116

**KNOWN:** Horizontal square panel removed from an oven and cooled in quiescent or moving air.

**FIND:** Initial convection heat rates for both methods of cooling.

**SCHEMATIC:**

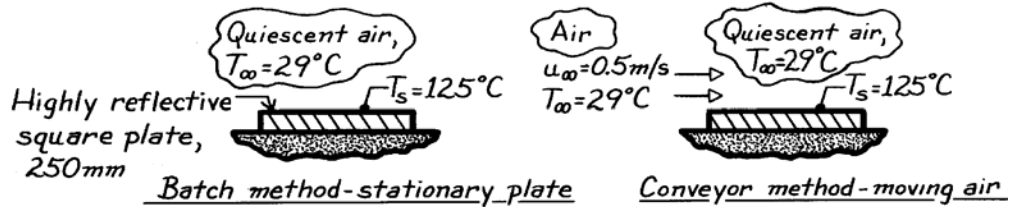

**ASSUMPTIONS:** (1) Quasi-steady state conditions, (2) Backside of plates insulated, (3) Air flow is in the length-wise (not diagonal) direction, (4) Constant properties, (5) Radiative exchange negligible.

**PROPERTIES:** Table A-4, Air ( $T_f = (T_\infty + T_s)/2 = 350\text{K}$ , 1 atm):  $\nu = 20.92 \times 10^{-6} \text{ m}^2/\text{s}$ ,  $k = 0.030 \text{ W/m}\cdot\text{K}$ ,  $\alpha = 29.9 \times 10^{-6} \text{ m}^2/\text{s}$ ,  $\text{Pr} = 0.700$ ,  $\beta = 1/T_f$ .

**ANALYSIS:** The initial heat transfer rate from the plates by convection is given by the rate equation  $q = \bar{h} A_s (T_s - T_\infty)$ . Test for the existence of combined free-forced convection by calculation of the ratio  $\text{Gr}_L / \text{Re}_L^2$ . Use the same characteristic length in both parameters,  $L = 250\text{mm}$ , the side length.

$$\text{Gr}_L = \frac{g \beta \Delta T L^3}{\nu^2} = \frac{9.8 \text{ m/s}^2 (1/350\text{K})(125 - 29) \text{ K} (0.250\text{m})^3}{(20.92 \times 10^{-6} \text{ m}^2/\text{s})^2} = 9.597 \times 10^7$$

$$\text{Re}_L = u_\infty L / \nu = 0.5 \text{ m/s} \times 0.250 \text{ m} / (20.92 \times 10^{-6} \text{ m}^2/\text{s}) = 5.975 \times 10^3.$$

Since  $\text{Gr}_L / \text{Re}_L^2 = 2.69$  flow is mixed. For the *stationary plate*,  $\text{Ra}_L = \text{Gr}_L \cdot \text{Pr} = 6.718 \times 10^7$  and Eq. 9.31 is the appropriate correlation,

$$\overline{\text{Nu}}_N = \frac{\bar{h}L}{k} = 0.15 \text{ Ra}_L^{1/3} = 0.15 (6.718 \times 10^7)^{1/3} = 60.9$$

$$\bar{h} = (0.030 \text{ W/m}\cdot\text{K} / 0.250\text{m}) \times 60.9 = 7.31 \text{ W/m}^2 \cdot \text{K}.$$

$$q = 7.31 \text{ W/m}^2 \cdot \text{K} \times (0.250\text{m})^2 (125 - 29) \text{ K} = 43.9 \text{ W}. \quad <$$

For the *plate with moving air*,  $\text{Re}_L = 5.975 \times 10^3$  and the flow is laminar.

$$\overline{\text{Nu}}_F = 0.664 \text{ Re}_L^{1/2} \text{ Pr}^{1/3} = 0.664 (5.975 \times 10^3)^{1/2} (0.700)^{1/3} = 45.6.$$

For combined free-forced convection, use the correlating equation with  $n = 7/2$ .

$$\overline{\text{Nu}}^{7/2} = \overline{\text{Nu}}_F^{7/2} + \overline{\text{Nu}}_N^{7/2} = (45.6)^{7/2} + (60.9)^{7/2} \quad \overline{\text{Nu}} = 66.5.$$

$$\bar{h} = \overline{\text{Nu}} k / L = 66.5 (0.030 \text{ W/m}\cdot\text{K} / 0.25\text{m}) = 7.99 \text{ W/m}^2 \cdot \text{K}$$

$$q = 7.99 \text{ W/m}^2 \cdot \text{K} (0.250\text{m})^2 (125 - 29) \text{ K} = 47.9 \text{ W}. \quad <$$

**COMMENTS:** (1) The conveyor method provides only slight enhancement of heat transfer.

### PROBLEM 9.117

**KNOWN:** Wet garment at 25°C hanging in a room with still, dry air at 40°C.

**FIND:** Drying rate per unit width of garment.

**SCHEMATIC:**

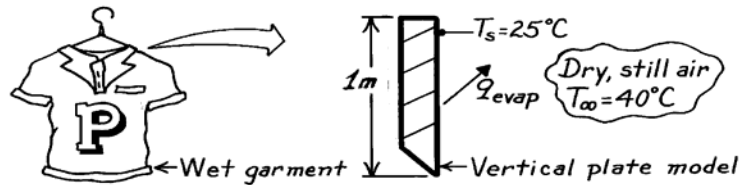

**ASSUMPTIONS:** (1) Analogy between heat and mass transfer applies, (2) Water vapor at garment surface is saturated at  $T_s$ , (3) Perfect gas behavior of vapor and air.

**PROPERTIES:** Table A-4, Air ( $T_f \approx (T_s + T_\infty)/2 = 305\text{K}$ , 1 atm):  $\nu = 16.39 \times 10^{-6} \text{ m}^2/\text{s}$ ; Table A-6, Water vapor ( $T_s = 298\text{K}$ , 1 atm):  $p_{A,s} = 0.0317 \text{ bar}$ ,  $\rho_{A,s} = 1/\nu_f = 0.02660 \text{ kg/m}^3$ ; Table A-8, Air-water vapor (305 K):  $D_{AB} = 0.27 \times 10^{-4} \text{ m}^2/\text{s}$ ,  $Sc = \nu/D_{AB} = 0.607$ .

**ANALYSIS:** The drying rate per unit width of the garment is

$$\dot{m}'_A = \bar{h}_m \cdot L (\rho_{A,s} - \rho_{A,\infty})$$

where  $\bar{h}_m$  is the mass transfer coefficient associated with a vertical surface that models the garment. From the heat and mass transfer analogy, Eq. 9.24 with  $C$  and  $n$  from Section 9.6.1 yields

$$\bar{Sh}_L = 0.59 (\text{Gr}_L \text{Sc})^{1/4}$$

where  $\text{Gr}_L = g\Delta\rho L^3/\rho\nu^2$  and  $\Delta\rho = \rho_s - \rho_\infty$ . Since the still air is dry,  $\rho_\infty = \rho_{B,\infty} = p_{B,\infty}/R_B T_\infty$ , where  $R_B = \mathcal{R}/\mathcal{M}_B = 8.314 \times 10^{-2} \text{ m}^3 \cdot \text{bar}/\text{kg} \cdot \text{K}/29 \text{ kg}/\text{kmol} = 0.00287 \text{ m}^3 \cdot \text{bar}/\text{kg} \cdot \text{K}$ . With  $p_{B,\infty} = 1 \text{ atm} = 1.0133 \text{ bar}$ ,

$$\rho_\infty = \frac{1.0133 \text{ bar}}{0.00287 \text{ m}^3 \cdot \text{bar}/\text{kg} \cdot \text{K} \times 313 \text{ K}} = 1.1280 \text{ kg/m}^3$$

The density of the air/vapor mixture at the surface is  $\rho_s = \rho_{A,s} + \rho_{B,s}$ . With  $p_{B,s} = 1 \text{ atm} - p_{A,s} = 1.0133 \text{ bar} - 0.0317 \text{ bar} = 0.9816 \text{ bar}$ ,

$$\rho_{B,s} = \frac{p_{B,s}}{R_B T_s} = \frac{0.9816 \text{ bar}}{0.00287 (\text{m}^3 \cdot \text{bar}/\text{kg} \cdot \text{K}) \times 298 \text{ K}} = 1.1477 \text{ kg/m}^3$$

Hence,  $\rho_s = (0.0266 + 1.1477) \text{ kg/m}^3 = 1.1743 \text{ kg/m}^3$  and  $\rho = (\rho_s + \rho_\infty)/2 = 1.1512 \text{ kg/m}^3$ . The Grashof number is then

$$\text{Gr}_L = \frac{9.8 \text{ m/s}^2 \times (1.1743 - 1.1280) \text{ kg/m}^3 (1 \text{ m})^3}{1.1512 \text{ kg/m}^3 \times (16.39 \times 10^{-6} \text{ m}^2/\text{s})^2} = 1.467 \times 10^9$$

and  $(\text{Gr}_L \text{Sc}) = 8.905 \times 10^8$ . The convection coefficient is then

$$\bar{h}_m = \frac{D_{AB}}{L} \bar{Sh}_L = \frac{0.27 \times 10^{-4} \text{ m}^2/\text{s}}{1 \text{ m}} \times 0.59 (8.905 \times 10^8)^{1/4} = 0.00275 \text{ m/s}$$

The drying rate is then

$$\dot{m}'_A = 2.750 \times 10^{-3} \text{ m/s} \times 1.0 \text{ m} (0.0226 - 0) \text{ kg/m}^3 = 6.21 \times 10^{-5} \text{ kg/s} \cdot \text{m} \quad <$$

**COMMENTS:** Since  $\rho_s > \rho_\infty$ , the buoyancy driven flow *descends* along the garment.

## PROBLEM 9.118

**KNOWN:** A water bath maintained at a uniform temperature of 37°C with top surface exposed to draft-free air and uniform temperature walls in a laboratory.

**FIND:** (a) The heat loss from the surface of the bath by radiation exchange with the surroundings; (b) Calculate the Grashof number using Eq. 9.65 with a characteristic length  $L$  that is appropriate for the exposed surface of the water bath; (c) Estimate the free convection heat transfer coefficient using the result for  $Gr_L$  obtained in part (b); (d) Invoke the heat-mass analogy and use an appropriate correlation to estimate the mass transfer coefficient using  $Gr_L$ ; calculate the water evaporation rate on a daily basis and the heat loss by evaporation; and (e) Calculate the total heat loss from the surface and compare relative contributions of the sensible, latent and radiative effects. Review assumptions made in your analysis, especially those relating to the heat-mass analogy.

**SCHEMATIC:**

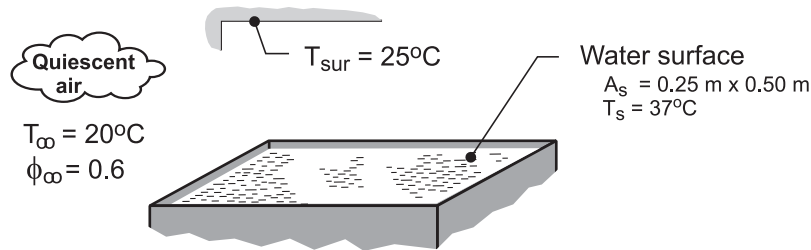

**ASSUMPTIONS:** (1) Steady-state conditions, (2) Laboratory air is quiescent, (3) Laboratory walls are isothermal and large compared to water bath exposed surface, (4) Emissivity of the water surface is 0.96, (5) Heat-mass analogy is applicable, and (6) Constant properties.

**PROPERTIES:** Table A-6, Water vapor ( $T_\infty = 293$  K):  $\rho_{A,\infty,\text{sat}} = 0.01693$  kg/m<sup>3</sup>; ( $T_s = 310$  K):  $\rho_{A,s} = 0.04361$  kg/m<sup>3</sup>,  $h_{fg} = 2.414 \times 10^6$  J/kg; Table A-4, Air ( $T_\infty = 293$  K, 1 atm):  $\rho_{B,\infty} = 1.194$  kg/m<sup>3</sup>; ( $T_s = 310$  K, 1 atm):  $\rho_{B,s} = 1.128$  kg/m<sup>3</sup>; ( $T_f = (T_s + T_\infty)/2 = 302$  K, 1 atm):  $\nu_B = 1.604 \times 10^{-5}$  m<sup>2</sup>/s,  $k = 0.0270$  W/m·K,  $Pr = 0.706$ ; Table A-8, Water vapor-air ( $T_f = 302$  K, 1 atm):  $D_{AB} = 0.24 \times 10^{-4}$  m<sup>2</sup>/s  $(302/298)^{3/2} = 2.45 \times 10^{-5}$  m<sup>2</sup>/s.

**ANALYSIS:** (a) Using the linearized form of the radiation exchange rate equation, the heat rate and radiation coefficient can be estimated.

$$h_{\text{rad}} = \varepsilon\sigma(T_s + T_{\text{sur}})(T_s^2 + T_{\text{sur}}^2) \quad (1)$$

$$h_{\text{rad}} = 0.96\sigma(310 + 298)(310^2 + 298^2) \text{ K}^3 = 6.12 \text{ W/m}^2 \cdot \text{K} \quad <$$

$$q_{\text{rad}} = h_{\text{rad}}A_s(T_s - T_{\text{sur}}) \quad (2)$$

$$q_{\text{rad}} = 6.12 \text{ W/m}^2 \cdot \text{K} \times (0.25 \times 0.50) \text{ m}^2 \times (37 - 25) \text{ K} = 9.18 \text{ W}$$

(b) The general form of the Grashof number, Eq. 9.65, applied to natural convection flows driven by concentration gradients

$$Gr_L = g(\rho_\infty - \rho_s)L^3 / \rho\nu^2 \quad (3)$$

where  $L$  is the characteristic length defined in Eq. 9.29 as  $L = A_s/P$ , where  $A_s$  and  $P$  are the exposed surface area and perimeter, respectively;  $\rho_s$  and  $\rho_\infty$  are the density of the mixture at the surface and in the quiescent fluid, respectively; and,  $\rho$  is the mean boundary layer density,  $(\rho_\infty + \rho_s)/2$ , and  $\nu$  is the kinematic viscosity of fluid B, evaluated at the film temperature  $T_f = (T_s + T_\infty)/2$ . Using the property values from above,

Continued ...

**PROBLEM 9.118 (Cont.)**

$$\rho_s = \rho_{A,s} + \rho_{B,s} = (0.04361 + 1.128) \text{ kg/m}^3 = 1.1716 \text{ kg/m}^3$$

$$\rho_\infty = \rho_{A,\infty} + \rho_{B,\infty} = \phi_\infty \rho_{A,\infty,\text{sat}} + \rho_{B,\infty}$$

$$\rho_\infty = (0.6 \times 0.01693 + 1.194) \text{ kg/m}^3 = 1.2042 \text{ kg/m}^3$$

$$\rho = (\rho_s + \rho_\infty) / 2 = 1.188 \text{ kg/m}^3$$

Substituting numerical values in Eq. (3), find the Grashof number.

$$\text{Gr}_L = \frac{9.8 \text{ m/s}^2 (1.2042 - 1.1716) \text{ kg/m}^3 \times (0.0833 \text{ m})^3}{1.188 \text{ kg/m}^3 (1.604 \times 10^{-5} \text{ m}^2/\text{s})^2}$$

$$\text{Gr}_L = 6.040 \times 10^5$$

&lt;

where the characteristic length is defined by Eq. 9.29,

$$L = A_s / P = (0.25 \times 0.5) \text{ m}^2 / 2(0.25 + 0.50) \text{ m} = 0.0833 \text{ m}$$

(c) The free convection heat transfer coefficient for the horizontal surface, Eq. 9.30, for *upper surface of heated plate*, is estimated as follows:

$$\text{Ra}_L = \text{Gr}_L \text{Pr}_L = 6.040 \times 10^5 \times 0.706 = 4.264 \times 10^5$$

$$\overline{\text{Nu}}_L = \frac{\bar{h}L}{k} = 0.54 \text{ Ra}_L^{1/4} = 13.80$$

$$\bar{h} = 13.80 \times 0.0270 \text{ W/m} \cdot \text{K} / 0.0833 \text{ m} = 4.47 \text{ W/m}^2 \cdot \text{K}$$

&lt;

(d) Invoking the heat-mass analogy, the mass transfer coefficient is estimated as follows,

$$\text{Ra}_{L,m} = \text{Gr}_L \text{Sc} = 6.040 \times 10^5 \times 0.655 = 3.954 \times 10^5$$

where the Schmidt number is given as

$$\text{Sc} = \nu / D_{AB} = 1.604 \times 10^{-5} \text{ m}^2/\text{s} / 2.45 \times 10^{-5} \text{ m}^2/\text{s} = 0.655$$

The correlation has the form

$$\overline{\text{Sh}}_L = \frac{\bar{h}_m L}{D_{AB}} = 0.54 \text{ Ra}_{L,m}^{1/4} = 13.54$$

$$\bar{h}_m = 13.54 \times 2.45 \times 10^{-5} \text{ m}^2/\text{s} / 0.0833 \text{ m} = 0.00398 \text{ m/s}$$

&lt;

The water evaporation rate on a daily basis is

$$n_A = \bar{h}_m A_s (\rho_{A,\text{sat}} - \rho_{A,\infty})$$

$$n_A = 0.00398 \text{ m/s} (0.25 \times 0.50) \text{ m}^2 (0.04361 - 0.6 \times 0.01693) \text{ kg/m}^3$$

Continued ...

**PROBLEM 9.118 (Cont.)**

$$n_A = 1.66 \times 10^{-5} \text{ kg/s} = 1.44 \text{ kg/day} \quad <$$

and the *heat loss by evaporation* is

$$q_{\text{evap}} = n_A h_{\text{fg}} = 1.66 \times 10^{-5} \text{ kg/s} \times 2.414 \times 10^6 \text{ J/kg} = 40.2 \text{ W} \quad <$$

(e) The *convective heat loss* is that of free convection,

$$q_{\text{cv}} = \bar{h} A_s (T_s - T_\infty)$$

$$q_{\text{cv}} = 4.47 \text{ W/m}^2 \times (0.25 \times 0.50) \text{ m}^2 (37 - 20) \text{ K} = 9.50 \text{ W} \quad <$$

In summary, the *total heat loss* from the surface of the bath, which must be supplied as electrical power to the bath heaters, is

$$q_{\text{tot}} = q_{\text{rad}} + q_{\text{cv}} + q_{\text{evap}}$$

$$q_{\text{tot}} = (9.18 + 9.50 + 40.2) \text{ W} = 59 \text{ W} \quad <$$

The *sensible heat losses* are by convection ( $q_{\text{rad}} + q_{\text{cv}}$ ), which represent 31% of the total; the balance is the *latent loss* by evaporation, 68%.

## PROBLEM 9.119

**KNOWN:** Diameter and surface temperature of lake. Temperature and relative humidity of air. Surroundings temperature.

**FIND:** Heat loss from lake by radiation, free convection, and evaporation. Justify use of heat transfer correlation outside of  $Ra_L$  range.

**SCHEMATIC:**

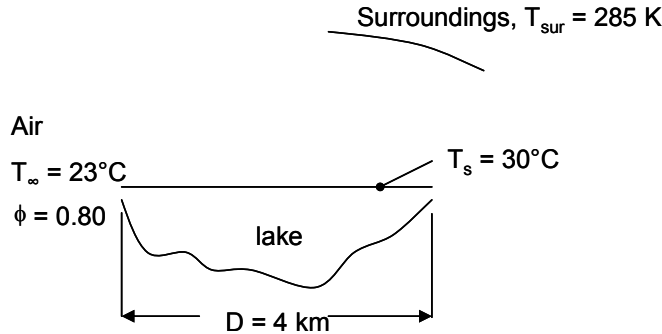

**ASSUMPTIONS:** (1) Steady-state conditions. (2) Negligible breeze. (3) Heat-mass transfer analogy is applicable. (4) Heat transfer correlation can be used outside of  $Ra_L$  range.

**PROPERTIES:** Table A-6, Water vapor ( $T_{\infty} = 296 \text{ K}$ ):  $\rho_{A,\infty,sat} = 0.02025 \text{ kg/m}^3$ ; ( $T_s = 303 \text{ K}$ ):  $\rho_{A,s} = 0.02985 \text{ kg/m}^3$ ,  $h_{fg} = 2.431 \times 10^6 \text{ J/kg}$ ; Table A-4, Air ( $T_{\infty} = 296 \text{ K}$ , 1 atm):  $\rho_{B,\infty} = 1.180 \text{ kg/m}^3$ ; ( $T_s = 303 \text{ K}$ , 1 atm):  $\rho_{B,s} = 1.151 \text{ kg/m}^3$ ; ( $T_f = (T_s + T_{\infty})/2 \approx 300 \text{ K}$ , 1 atm):  $\nu_B = 1.589 \times 10^{-5} \text{ m}^2/\text{s}$ ,  $k = 0.0263 \text{ W/m}\cdot\text{K}$ ,  $Pr = 0.707$ ; Table A-8, Water vapor-air ( $T_f \approx 300 \text{ K}$ , 1 atm):  $D_{AB} = 0.26 \times 10^{-4} \text{ m}^2/\text{s}$  ( $300/298$ )<sup>3/2</sup> =  $2.63 \times 10^{-5} \text{ m}^2/\text{s}$ ; Table A-11, Water ( $T_s \approx 300 \text{ K}$ ):  $\varepsilon = 0.96$ .

**ANALYSIS:** The radiation heat transfer can be calculated from

$$q_{rad} = \varepsilon \sigma A_s (T_s^4 - T_{sur}^4) \quad (1)$$

$$= 0.96 \times 5.67 \times 10^{-8} \text{ W/m}^2 \cdot \text{K}^4 \times \frac{\pi(4000 \text{ m})^2}{4} \times (303^4 - 285^4) \text{ K}^4 = 1253 \text{ MW} <$$

The natural convection above the lake surface is driven by the combination of temperature and concentration gradient. The general form of the Grashof number, Equation 9.65, is

$$Gr_L = g(\rho_{\infty} - \rho_s)L^3 / \rho \nu^2 \quad (2)$$

where  $L$  is the characteristic length defined in Eq. 9.29 as  $L = A_s/P$ , where  $A_s$  and  $P$  are the exposed surface area and perimeter, respectively;  $\rho_s$  and  $\rho_{\infty}$  are the density of the mixture at the surface and in the quiescent fluid, respectively;  $\rho$  is the mean boundary layer density,  $(\rho_{\infty} + \rho_s)/2$ ; and  $\nu$  is the kinematic viscosity of the mixture (approximated here as the value for pure air), evaluated at the film temperature  $T_f = (T_s + T_{\infty})/2$ . Using the property values from above,

$$\rho_s = \rho_{A,s} + \rho_{B,s} = (0.02985 + 1.151) \text{ kg/m}^3 = 1.181 \text{ kg/m}^3$$

$$\rho_{\infty} = \rho_{A,\infty} + \rho_{B,\infty} = \phi_{\infty} \rho_{A,\infty,sat} + \rho_{B,\infty}$$

$$\rho_{\infty} = (0.8 \times 0.02025 + 1.180) \text{ kg/m}^3 = 1.196 \text{ kg/m}^3$$

$$\rho = (\rho_s + \rho_{\infty})/2 = 1.189 \text{ kg/m}^3$$

$$L = A_s / P = \left( \frac{\pi(4000)^2}{4} \right) \text{ m}^2 / \pi(4000) \text{ m} = 1000 \text{ m}$$

Substituting numerical values in Equation (2) for the Grashof number,

Continued...



**PROBLEM 9.119 (Cont.)**

$$\text{Gr}_L = \frac{9.8 \text{ m/s}^2 (1.196 - 1.181) \text{ kg/m}^3 \times (1000 \text{ m})^3}{1.189 \text{ kg/m}^3 \left(1.589 \times 10^{-5} \text{ m}^2/\text{s}\right)^2} = 5.01 \times 10^{17}$$

Then  $\text{Ra}_L = \text{Gr}_L \text{Pr} = 5.01 \times 10^{17} \times 0.707 = 3.54 \times 10^{17}$  <

The free convection heat transfer coefficient for the upper surface of a hot plate is given by Equation 9.31, but the Rayleigh number is larger than the upper limit specified for this correlation. However, since  $\text{Ra}_L$  is raised to the 1/3 power, this correlation yields a heat transfer coefficient which is independent of  $L$ . Therefore it is reasonable to expect that the heat transfer coefficient calculated by this correlation is valid even though  $\text{Ra}_L$  is outside the range. Proceeding,

$$\overline{\text{Nu}}_L = \frac{\overline{h}L}{k} = 0.15 \text{ Ra}_L^{1/3} = 1.06 \times 10^5$$

$$\overline{h} = 1.06 \times 10^5 \times 0.0263 \text{ W/m} \cdot \text{K} / 1000 \text{ m} = 2.79 \text{ W/m}^2 \cdot \text{K}$$

$$q_{\text{cv}} = \overline{h}A_s (T_s - T_\infty)$$

$$q_{\text{cv}} = 2.79 \text{ W/m}^2 \times \left( \frac{\pi(4000)^2}{4} \right) \text{m}^2 (30 - 23) \text{ K} = 246 \text{ MW}$$
 <

Invoking the heat-mass analogy, the mass transfer coefficient is estimated as follows,

$$\text{Ra}_{L,m} = \text{Gr}_L \text{Sc} = 5.01 \times 10^{17} \times 0.604 = 3.03 \times 10^{17}$$

where the Schmidt number is given as

$$\text{Sc} = \nu / D_{\text{AB}} = 1.589 \times 10^{-5} \text{ m}^2/\text{s} / 2.63 \times 10^{-5} \text{ m}^2/\text{s} = 0.604$$

The correlation has the form

$$\overline{\text{Sh}}_L = \frac{\overline{h}_m L}{D_{\text{AB}}} = 0.15 \text{ Ra}_{L,m}^{1/3} = 1.01 \times 10^5$$

$$\overline{h}_m = 1.01 \times 10^5 \times 2.63 \times 10^{-5} \text{ m}^2/\text{s} / 1000 \text{ m} = 2.65 \times 10^{-3} \text{ m/s}$$

The water evaporation rate on a daily basis is

$$n_A = \overline{h}_m A_s (\rho_{\text{A,sat}} - \rho_{\text{A},\infty})$$

$$n_A = 2.65 \times 10^{-3} \text{ m/s} \times \pi(4000^2/4) \text{m}^2 (0.02985 - 0.8 \times 0.02025) \text{ kg/m}^3$$

$$n_A = 4.54 \times 10^2 \text{ kg/s} = 3.93 \times 10^7 \text{ kg/day}$$

and the *heat loss by evaporation* is

$$q_{\text{evap}} = n_A h_{\text{fg}} = 4.54 \times 10^2 \text{ kg/s} \times 2.431 \times 10^6 \text{ J/kg} = 1105 \text{ MW}$$
 <

In summary, the *total heat loss* from the surface of the lake, which determines the rate at which the lake can be used to cool the condenser, is

$$q_{\text{tot}} = q_{\text{rad}} + q_{\text{cv}} + q_{\text{evap}} = 1253 \text{ MW} + 246 \text{ MW} + 1105 \text{ MW} = 2604 \text{ MW}$$
 <

**COMMENTS:** The *sensible heat losses* are by convection ( $q_{\text{rad}} + q_{\text{cv}}$ ), which represent 58% of the total; the balance is the *latent loss* by evaporation, 42%.

## PROBLEM 9.120

**KNOWN:** Fuel cell cathode dimensions, oxygen mass fraction in the ambient and adjacent to the cathode, orientation of cathode, relationship between oxygen transfer rate and electrical current.

**FIND:** Maximum possible electrical current produced by the fuel cell.

**SCHEMATIC:**

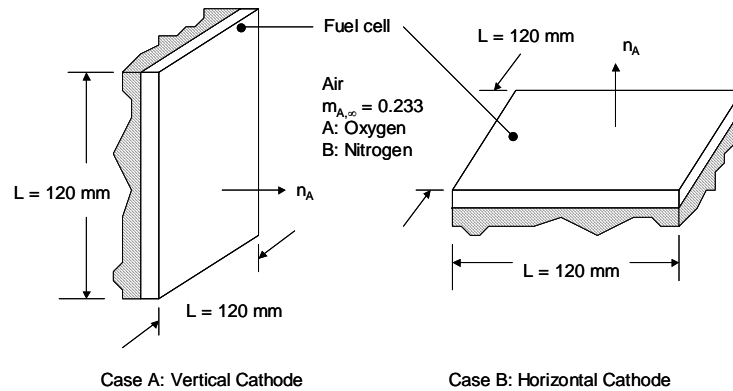

**ASSUMPTIONS:** (1) Ideal gas behavior, (2) Isothermal conditions, (3) Thermophysical properties of species B are those of air, except for the mass density.

**PROPERTIES:** Table A.4, air: ( $p = 1 \text{ atm}$ ,  $T_f = 298 \text{ K}$ ):  $\nu = 1.571 \times 10^{-5} \text{ m}^2/\text{s}$ , Table A.8, oxygen in air:  $D_{AB} = 0.21 \times 10^{-4} \text{ m}^2/\text{s}$ .

**ANALYSIS:** The molecular weights of oxygen (A) and nitrogen (B) are  $\mathcal{M}_A = 32 \text{ kg/kmol}$  and  $\mathcal{M}_B = 28 \text{ kg/kmol}$ , respectively. The mole fraction of A in the ambient is  $x_{A,\infty} = (m_{A,\infty}/\mathcal{M}_A)/[m_{A,\infty}/\mathcal{M}_A + (1 - m_{A,\infty})/\mathcal{M}_B] = (0.233/32 \text{ kg/kmol})/[0.233/32 \text{ kg/kmol} + (1 - 0.233)/28 \text{ kg/kmol}] = 0.210$ . Therefore,  $x_{B,\infty} = 1 - 0.210 = 0.790$ . The molecular weight of the ambient gas is  $\mathcal{M}_\infty = x_{A,\infty}\mathcal{M}_A + (1 - x_{A,\infty})\mathcal{M}_B = 0.210 \times 32 \text{ kg/kmol} + (1 - 0.210) \times 28 \text{ kg/kmol} = 28.84 \text{ kg/mol}$ . The gas constant of the ambient is  $R_\infty = \mathcal{R}/\mathcal{M}_\infty = 8.315 \text{ kJ/kmol}\cdot\text{K}/28.84 \text{ kg/kmol} = 288.3 \times 10^{-3} \text{ kJ/kg}\cdot\text{K}$ .

The mole fraction of A at the surface is  $x_{A,s} = (m_{A,s}/\mathcal{M}_A)/[m_{A,s}/\mathcal{M}_A + (1 - m_{A,s})/\mathcal{M}_B] = (0.10/32 \text{ kg/kmol})/[0.1/32 \text{ kg/kmol} + (1-0.1)/28\text{kg/kmol}] = 0.089$ . Therefore,  $x_{B,s} = 1 - 0.089 = 0.911$ . The molecular weight of the gas at the surface is  $\mathcal{M}_s = x_{A,s}\mathcal{M}_A + (1 - x_{A,s})\mathcal{M}_B = 0.089 \times 32 \text{ kg/kmol} + (1 - 0.089) \times 28 \text{ kg/kmol} = 28.36 \text{ kg/kmol}$ . The gas constant of the fluid at the surface is  $R_s = \mathcal{R}/\mathcal{M}_s = 8.315 \text{ kJ/kmol}\cdot\text{K}/28.36 \text{ kg/kmol} = 293.2 \times 10^{-3} \text{ kJ/kg}\cdot\text{K}$ .

The ambient gas density is

$$\rho_\infty = \frac{p}{R_\infty T} = \frac{1.0133 \times 10^5 \text{ N/m}^2}{288.3 \times 10^{-3} \text{ kJ/kg}\cdot\text{K} \times (25 + 273) \text{ K}} \times 0.001 \text{ kJ/J} = 1.1794 \text{ kg/m}^3$$

The surface gas density is

Continued...

**PROBLEM 9.120 (Cont.)**

$$\rho_s = \frac{p}{R_s T} = \frac{1.0133 \times 10^5 \text{ N/m}^2}{293.2 \times 10^{-3} \text{ kJ/kg} \cdot \text{K} \times (25 + 273) \text{ K}} \times 0.001 \text{ kJ/J} = 1.1597 \text{ kg/m}^3$$

The average gas density is  $\rho = (1.1794 \text{ kg/m}^3 + 1.1597 \text{ kg/m}^3)/2 = 1.1696 \text{ kg/m}^3$ .

Case a: Vertical Cathode. The Rayleigh number is

$$\begin{aligned} \text{Ra}_L &= \text{Gr}_L \text{Sc} = \left[ g(\rho_s - \rho_\infty) L^3 / \rho v^2 \right] \times [v / D_{AB}] \\ &= \frac{9.8 \text{ m/s}^2 \times (1.1597 - 1.1794) \text{ kg/m}^3 \times (0.12 \text{ m})^3}{1.1696 \text{ kg/m}^3 \times 1.571 \times 10^{-5} \text{ m}^2/\text{s} \times 0.21 \times 10^{-4} \text{ m}^2/\text{s}} = 865 \times 10^3 \end{aligned}$$

and the Schmidt number is  $\text{Sc} = v/D_{AB} = 1.571 \times 10^{-5} \text{ m}^2/\text{s} / 0.21 \times 10^{-4} \text{ m}^2/\text{s} = 0.748$ . The heat and mass transfer analogy may be applied to the Churchill and Chu correlation to yield

$$\begin{aligned} \bar{h}_{m,L} &= \frac{D_{AB}}{L} \left\{ 0.825 + \frac{0.387 \text{Ra}_L^{1/6}}{\left[ 1 + (0.492/\text{Sc})^{9/16} \right]^{8/27}} \right\}^2 \\ &= \frac{0.21 \times 10^{-4} \text{ m}^2/\text{s}}{0.12 \text{ m}} \times \left\{ 0.825 + \frac{0.387 \times (865 \times 10^3)^{1/6}}{\left[ 1 + (0.492/0.748)^{9/16} \right]^{8/27}} \right\}^2 = 0.0028 \text{ m/s} \end{aligned}$$

The mass transfer rate is

$$\begin{aligned} n_A &= \bar{h}_{m,L} A_s (\rho_{A,s} - \rho_{A,\infty}) = 0.0028 \text{ m/s} \times (0.12 \text{ m})^2 \times (1.1597 \text{ kg/m}^3 \times 0.1 - 1.1794 \text{ kg/m}^3 \times 0.233) \\ &= -6.4 \times 10^{-6} \text{ kg/s} \end{aligned}$$

The negative sign implies oxygen transfer to the cathode. The electric current is

$$I = 4n_A F / \mathcal{M}_A = \frac{4 \times 6.4 \times 10^{-6} \text{ kg/s} \times 96489 \text{ coulombs/mol} \times 1000 \text{ mol/kmol}}{32 \text{ kg/kmol}} = 77 \text{ A} <$$

Case b: Horizontal, Upward Facing Cathode. Since  $\rho_s < \rho_\infty$ , the analogous situation is the upper surface of a hot plate. The characteristic length is  $L = A_s/P = L^2/4L = L/4 = 0.12 \text{ m}/4 = 0.03 \text{ m}$ . The Rayleigh number is

$$\text{Ra}_L = \frac{9.8 \text{ m/s}^2 \times (1.1597 - 1.1794) \text{ kg/m}^3 \times (0.03 \text{ m})^3}{1.1696 \text{ kg/m}^3 \times 1.571 \times 10^{-5} \text{ m}^2/\text{s} \times 0.21 \times 10^{-4} \text{ m}^2/\text{s}} = 13500$$

Continued...

### PROBLEM 9.120 (Cont.)

From Equation 9.30,

$$\overline{Sh}_L = 0.54 \times (13500)^{1/4} = 5.82 \quad \text{and} \quad \overline{h}_L = \overline{Sh}_L D_{AB} / L = 5.82 \times 0.21 \times 10^{-4} \text{ m}^2 / \text{s} / 0.03 \text{ m} = 0.0041 \text{ m/s}$$

Hence, the mass transfer rate is

$$n_A = 0.0041 \text{ m/s} \times (0.12 \text{ m})^2 \times (1.1597 \text{ kg/m}^3 \times 0.1 - 1.1794 \text{ kg/m}^3 \times 0.233) = -9.38 \times 10^{-6} \text{ kg/s}$$

and the electric current is

$$I = \frac{4 \times 9.38 \times 10^{-6} \text{ kg/s} \times 96489 \text{ coulombs/mol} \times 1000 \text{ mol/kmol}}{32 \text{ kg/kmol}} = 102 \text{ A} \quad <$$

**COMMENTS:** Although the analysis is approximate because of the assumption of isothermal conditions, the fuel cell performance is clearly dependent upon its orientation.

## PROBLEM 10.1

**KNOWN:** Water at 1 atm with  $T_s - T_{\text{sat}} = 10^\circ\text{C}$ .

**FIND:** Show that the Jakob number is much less than unity; what is the physical significance of the result; does result apply to other fluids?

**ASSUMPTIONS:** (1) Boiling situation,  $T_s > T_{\text{sat}}$ .

**PROPERTIES:** *Table A-5 and Table A-6, (1 atm):*

	$h_{\text{fg}}$ (kJ/kg)	$c_{p,\ell}$ (J/kg·K)	$T_{\text{sat}}$ (K)
Water	2257	4217	373
Ethylene glycol	812	2742*	470
Mercury	301	135.5*	630
R-134a	217	1281	247

\* Estimated based upon value at highest temperature cited in Table A-5.

**ANALYSIS:** The Jakob number is the ratio of the maximum sensible energy absorbed by the vapor or liquid to the latent energy absorbed during boiling or condensation. That is,

$$\text{Ja} = c_p \Delta T / h_{\text{fg}}$$

The Jakob number can be based on the liquid or vapor specific heat depending on the circumstances. Since they are the same order of magnitude and we have liquid specific heats available for all the fluids listed above, we will use  $c_{p,\ell}$ .

For *water* with an excess temperature  $\Delta T_s = T_e - T_\infty = 10^\circ\text{C}$ , find

$$\text{Ja} = (4217 \text{ J/kg} \cdot \text{K} \times 10\text{K}) / 2257 \times 10^3 \text{ J/kg}$$

$$\text{Ja} = 0.019.$$

Since  $\text{Ja} \ll 1$ , the implication is that the sensible energy absorbed by the vapor is much less than the latent energy absorbed during the boiling phase change. Using the appropriate thermophysical properties for three other fluids, the Jakob numbers are:

$$\text{Ethylene glycol:} \quad \text{Ja} = (2742 \text{ J/kg} \cdot \text{K} \times 10\text{K}) / 812 \times 10^3 \text{ J/kg} = 0.0338 \quad <$$

$$\text{Mercury:} \quad \text{Ja} = (135.5 \text{ J/kg} \cdot \text{K} \times 10\text{K}) / 301 \times 10^3 \text{ J/kg} = 0.0045 \quad <$$

$$\text{Refrigerant, R-12:} \quad \text{Ja} = (1281 \text{ J/kg} \cdot \text{K} \times 10\text{K}) / 217 \times 10^3 \text{ J/kg} = 0.059 \quad <$$

For ethylene glycol and R-12, the Jakob number is larger than the value for water, but still much less than unity. Based upon these example fluids, we conclude that generally we'd expect Ja to be much less than unity.

**COMMENTS:** We would expect the same low value of Ja for the condensation process since  $c_{p,g}$  and  $c_{p,f}$  are of the same order of magnitude.

## PROBLEM 10.2

**KNOWN:** Diameter and temperature of horizontal cylinder or wire.

**FIND:** Heat flux due to natural convection and comparison with values shown in Figure 10.4

**SCHEMATIC:**

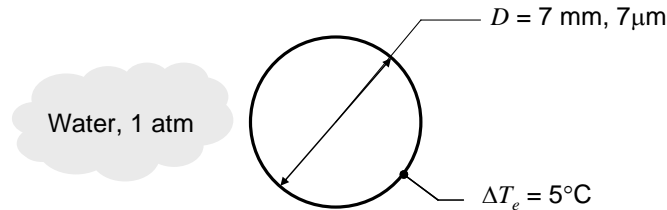

**ASSUMPTIONS:** (1) Constant properties, (2) No bubble nucleation.

**PROPERTIES:** Table A-6, Water (Saturated liquid,  $T_f = (T_{\text{sat}} + T_s)/2 = 102.5^\circ\text{C} = 375.5 \text{ K}$ ):  $k = 0.681 \text{ W/m}\cdot\text{K}$ ,  $\nu = 2.85 \times 10^{-7} \text{ m}^2/\text{s}$ ,  $\rho = 956.6 \text{ kg/m}^3$ ,  $c_p = 4221 \text{ J/kg}\cdot\text{K}$ ,  $Pr = 1.69$ ,  $\beta = 765 \times 10^{-6} \text{ K}^{-1}$ .

**ANALYSIS:** The thermal diffusivity is  $\alpha = k/\rho c_p = 0.681 \text{ W/m}\cdot\text{K}/(956.6 \text{ kg/m}^3 \times 4221 \text{ J/kg}\cdot\text{K}) = 1.68 \times 10^{-7} \text{ m}^2/\text{s}$ . For the  $D = 7 \text{ mm}$  cylinder, the Rayleigh number is

$$Ra_D = \frac{g\beta\Delta T_e D^3}{\nu\alpha} = \frac{9.81 \text{ m/s}^2 \times 765 \times 10^{-6} \text{ K}^{-1} \times 5 \text{ K} \times (7/1000 \text{ m})^3}{2.85 \times 10^{-7} \text{ m}^2/\text{s} \times 1.68 \times 10^{-7} \text{ m}^2/\text{s}} = 2.77 \times 10^5$$

Using the Churchill-Chu correlation,

$$\overline{Nu}_D = \frac{\bar{h}D}{k} = \left\{ 0.60 + \frac{0.387 Ra_D^{1/6}}{\left[ 1 + (0.559/Pr)^{9/16} \right]^{8/27}} \right\}^2 = \left\{ 0.60 + \frac{0.387 \times (2.77 \times 10^5)^{1/6}}{\left[ 1 + (0.559/1.69)^{9/16} \right]^{8/27}} \right\}^2 = 11.12$$

from which  $\bar{h} = \overline{Nu}_D k / D = 11.12 \times 0.681 \text{ W/m}\cdot\text{K} / (7/1000 \text{ m}) = 1083 \text{ W/m}^2 \cdot \text{K}$ .

Hence,  $q'' = h(\Delta T_e) = 1083 \text{ W/m}^2 \cdot \text{K} \times 5 \text{ K} = 5413 \text{ W/m}^2$ . <

The preceding calculations may be repeated for the  $D = 7 \mu\text{m}$  wire, yielding

$$Ra_D = 0.00027, \overline{Nu}_D = 0.471, \bar{h} = 4.586 \times 10^4 \text{ W/m}^2 \cdot \text{K}, q'' = 2.29 \times 10^5 \text{ W/m}^2. <$$

From Figure 10.4, the heat flux corresponding to  $\Delta T_e = 5^\circ\text{C}$  is approximately  $8,000 \text{ W/m}^2$ . The heat flux for the  $D = 7 \text{ mm}$  diameter cylinder is approximately 67% of this value. However, for the  $D = 7 \mu\text{m}$  wire, the heat flux is nearly 29 times greater than shown in Figure 10.4 and corresponds to values associated with vigorous nucleate boiling. Hence, Figure 10.4 is *not* generally applicable to all situations involving boiling of water at 1 atmosphere pressure and should be used, with caution, only in the absence of more detailed information. <

**Comments.** (1) Use of Equation 9.33 to calculate the heat flux for the wire yields

$\bar{h} = (0.681 \text{ W/m}\cdot\text{K} / 7 \times 10^{-6} \text{ m}) \times 0.675 \times 0.00027^{0.058} = 4.076 \times 10^4 \text{ W/m}^2 \cdot \text{K}$  and  $q'' = 2.04 \times 10^5 \text{ W/m}^2$ . This is in good agreement with the value calculated from the Churchill-Chu relation. (2) We would expect the boiling heat flux from the small wire to far exceed the values shown in Figure 10.4.

### PROBLEM 10.3

**KNOWN:** Spherical bubble of pure saturated vapor in mechanical and thermal equilibrium with its liquid.

**FIND:** (a) Expression for the bubble radius, (b) Bubble vapor and liquid states on a p-v diagram; how changes in these conditions cause bubble to collapse or grow, and (c) Bubble size for specified conditions.

**SCHEMATIC:**

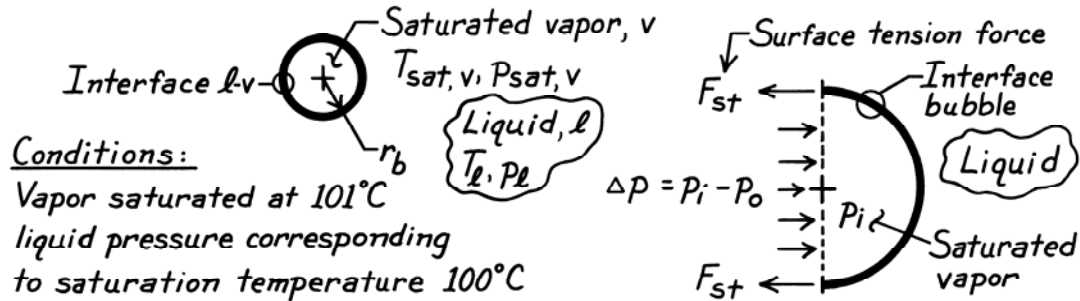

**ASSUMPTIONS:** (1) Liquid-vapor medium, (2) Thermal and mechanical equilibrium.

**PROPERTIES:** Table A-6, Water ( $T_{\text{sat}} = 101^\circ\text{C} = 374.15\text{K}$ ):  $p_{\text{sat}} = 1.0502\text{ bar}$ ; ( $T_{\text{sat}} = 100^\circ\text{C} = 373.15\text{K}$ ):  $p_{\text{sat}} = 1.0133\text{ bar}$ ,  $\sigma = 58.9 \times 10^{-3}\text{ N/m}$ .

**ANALYSIS:** (a) For mechanical equilibrium, the difference in pressure between the vapor inside the bubble and the liquid outside the bubble will be offset by the surface tension of the liquid-vapor interface. The force balance follows from the free-body diagram shown above (right),

$$F_{\text{St}} = (\pi r_b^2) \Delta p = (p_i - p_o) (\pi r_b^2)$$

$$(2\pi r_b) \sigma = (\pi r_b^2) (p_i - p_o)$$

$$r_b = 2\sigma / (p_i - p_o) \quad (1)$$

Thermal equilibrium requires that the temperatures of the vapor and liquid be equal. Since the vapor inside the bubble is saturated,  $p_i = p_{\text{sat},v}(T)$ . Since  $p_o < p_i$ , it follows that the liquid outside the bubble must be superheated; hence,  $p_o = p_\ell(T)$ , the pressure of superheated liquid at  $T$ . Hence, we can write,

$$r_b = 2\sigma / (p_{\text{sat},v} - p_\ell) \quad (2) <$$

(b) The vapor [1] and liquid [2] states are represented on the following p-v diagram. Thermal equilibrium requires both the vapor and liquid to be at the same temperature [3]. But mechanical equilibrium requires that the outside liquid pressure be less than the inside vapor pressure [4]. Hence the liquid must be in a superheated state. That is, its saturation temperature,  $T_{\text{sat}}(p_o)$  [5] is less than  $T_{\text{sat}}(p_i)$ ;  $T_\ell = T_{\text{sat}}(p_o)$  and  $p_o = p_\ell$ .

Continued ...

PROBLEM 10.3 (Cont.)

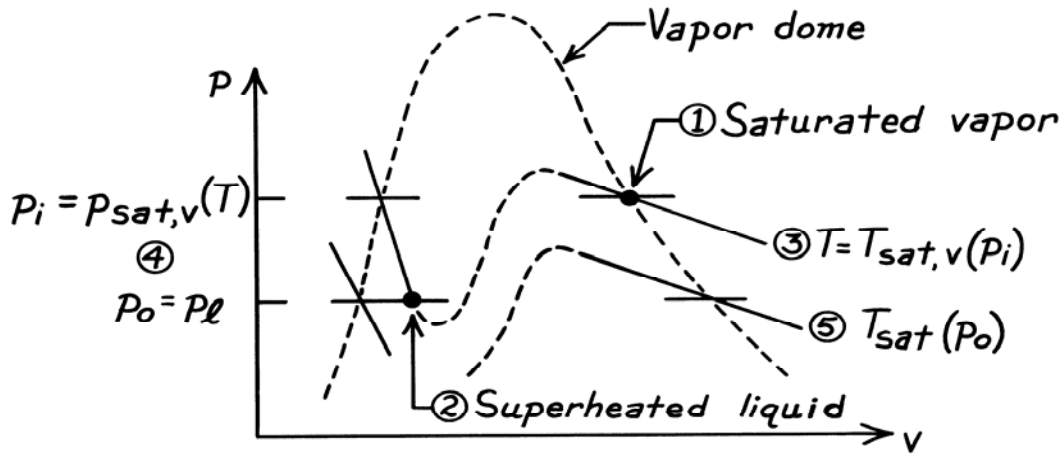

The equilibrium condition for the bubble is unstable. Consider situations for which the pressure of the surrounding liquid is greater or less than the equilibrium value. These situations are presented on portions of the p-v diagram

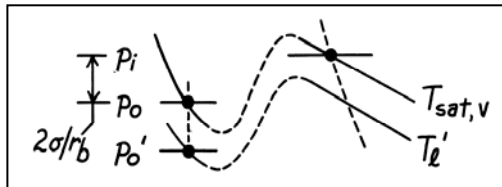

When  $p'_0 < p_0$ ,  $T'_\ell < T_{sat,v}$  and heat must be transferred out of the bubble and vapor condenses. Hence, the bubble collapses.

A similar argument for the condition  $p'_0 > p_0$  leads to  $T'_\ell > T_{sat,v}$  and heat is transferred into the bubble causing evaporation with the formation of vapor. Hence, the bubble begins to grow.

(c) Consider the specific conditions

$$T_{sat,v} = 101^\circ\text{C} \quad \text{and} \quad T_\ell = T_{sat}(p_0) = 100^\circ\text{C}$$

and calculate the radius of the bubble using the appropriate properties in Eq. (2).

$$r_b = 2 \times 58.9 \times 10^{-3} \frac{\text{N}}{\text{m}} / (1.0502 - 1.0133) \text{ bar} \times \left( 10^5 \frac{\text{N}}{\text{m}^2} / \text{bar} \right)$$

$$r_b = 0.032 \text{ mm.}$$

Note the small bubble size. This implies that nucleation sites of the same magnitude formed by pits and crevices are important in promoting the boiling process.



## PROBLEM 10.4

**KNOWN:** Boiling curve of Figure 10.4.

**FIND:** Heat transfer coefficient associated with Points A, B, C, D, and E. Which points are associated with the largest and smallest values of  $h$ . Thickness of vapor blanket at the Leidenfrost point.

**SCHEMATIC:**

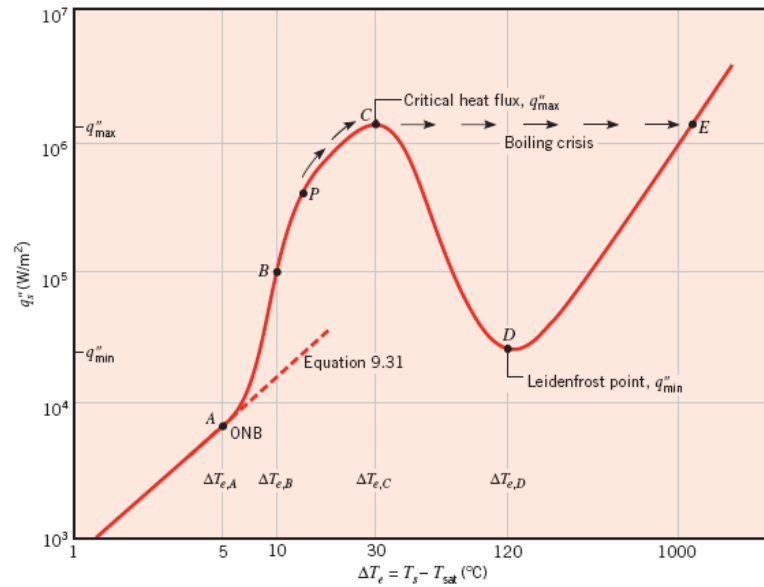

**ASSUMPTIONS:** (1) Neglect radiation during film boiling, (2) Surface is flat, (3) Vapor thermal conductivity can be evaluated at the film temperature.

**PROPERTIES:** Table A-6, Water vapor ( $T = 433 \text{ K}$ ) =  $0.0308 \text{ W/m} \cdot \text{K}$ .

**ANALYSIS:** Since  $h = q_s'' / \Delta T_e$ , the values of  $h$  can be found by reading  $q_s''$  and  $\Delta T_e$  from the graph.

Point	$q_s''$ ( $\text{W/m}^2$ )	$\Delta T_e$ ( $^\circ\text{C}$ )	$h$ ( $\text{W/m}^2 \cdot \text{K}$ )
A	6700	5	1300
B	$10^5$	10	10,000
C	$1.4 \times 10^6$	30	47,000
D	$2.5 \times 10^4$	120	210
E	$1.4 \times 10^6$	1200	1200

Among these points, the largest heat transfer coefficient occurs at point C, corresponding to the critical heat flux. The smallest heat transfer coefficient occurs at point D, the Leidenfrost point. <

Continued...

### PROBLEM 10.4 (Cont.)

At the Leidenfrost point, if radiation is neglected, heat transfer is due solely to conduction through the vapor film. The surface temperature is  $T_s = \Delta T_e + T_{\text{sat}} = 120^\circ\text{C} + 100^\circ\text{C} = 220^\circ\text{C}$ , so the film temperature is  $T_f = (220 + 100)^\circ\text{C}/2 = 160^\circ\text{C} = 433\text{ K}$ . Evaluating the vapor thermal conductivity at the film temperature, the film thickness is given by

$$\ell = k_v \Delta T_e / q'' = 0.0308\text{ W/m}\cdot\text{K} \times 120^\circ\text{C} / 2.5 \times 10^4\text{ W/m}^2 = 1.5 \times 10^{-4}\text{ m} = 0.15\text{ mm} \quad \leftarrow$$

**COMMENTS:** (1) Section 10.4.4 describes how to account for radiation heat transfer in film boiling. From Eq. 10.11, assuming  $\varepsilon = 1$  to maximize the effect of radiation, and using  $T_s = 220^\circ\text{C}$  corresponding to the Leidenfrost point, we find  $\bar{h}_{\text{rad}} = 19\text{ W/m}^2 \cdot \text{K}$ . This is considerably smaller than the overall heat transfer coefficient of  $h = 210\text{ W/m}^2 \cdot \text{K}$ . Figure 10.4 is based on experimental data, and therefore includes the effect of radiation, which becomes more significant as  $\Delta T_e$  increases. (2) Leidenfrost boiling can be observed by sprinkling water drops on a very hot flat pan surface. The vapor blanket beneath the droplets provides a means for the droplets to meander about the surface, and the droplets remain suspended for a relatively long time, indicative of relatively low heat transfer rates.

## PROBLEM 10.5

**KNOWN:** Long wire, 1 mm diameter, reaches a surface temperature of 126°C in water at 1 atm while dissipating 3150 W/m.

**FIND:** (a) Boiling heat transfer coefficient and (b) Correlation coefficient,  $C_{s,f}$ , if nucleate boiling occurs.

**SCHEMATIC:**

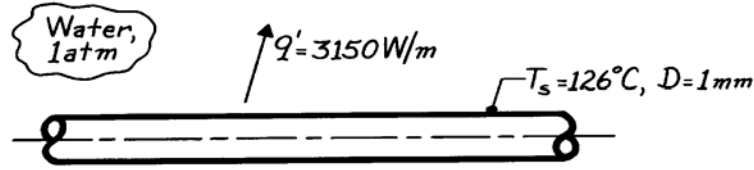

**ASSUMPTIONS:** (1) Steady-state conditions, (2) Nucleate boiling.

**PROPERTIES:** Table A-6, Water (saturated, 1 atm):  $T_s = 100^\circ\text{C}$ ,  $\rho_\ell = 1/v_f = 957.9 \text{ kg/m}^3$ ,  $\rho_v = 1/v_g = 0.5955 \text{ kg/m}^3$ ,  $c_{p,\ell} = 4217 \text{ J/kg}\cdot\text{K}$ ,  $\mu_\ell = 279 \times 10^{-6} \text{ N}\cdot\text{s/m}^2$ ,  $\text{Pr}_\ell = 1.76$ ,  $h_{fg} = 2257 \text{ kJ/kg}$ ,  $\sigma = 58.9 \times 10^{-3} \text{ N/m}$ .

**ANALYSIS:** (a) For the boiling process, the rate equation can be rewritten as

$$\bar{h} = q_s'' / (T_s - T_{\text{sat}}) = \frac{q_s'}{\pi D} / (T_s - T_{\text{sat}})$$

$$\bar{h} = \frac{3150 \text{ W/m}}{\pi \times 0.001 \text{ m}} / (126 - 100)^\circ\text{C} = 1.00 \times 10^6 \frac{\text{W}}{\text{m}^2} / 26^\circ\text{C} = 38,600 \text{ W/m}^2 \cdot \text{K} \quad <$$

Note the heat flux is very close to  $q''_{\text{max}}$ , and nucleate boiling does exist.

(b) For nucleate boiling, the Rohsenow correlation may be solved for  $C_{s,f}$  to give

$$C_{s,f} = \left\{ \frac{\mu_\ell h_{fg}}{q_s''} \right\}^{1/3} \left[ \frac{g(\rho_\ell - \rho_v)}{\sigma} \right]^{1/6} \left( \frac{c_{p,\ell} \Delta T_e}{h_{fg} \text{Pr}_\ell^n} \right).$$

Assuming the liquid-surface combination is such that  $n = 1$  and substituting numerical values with  $\Delta T_e = T_s - T_{\text{sat}}$ , find

$$C_{s,f} = \left\{ \frac{279 \times 10^{-6} \text{ N}\cdot\text{s/m}^2 \times 2257 \times 10^3 \text{ J/kg}}{1.00 \times 10^6 \text{ W/m}^2} \right\}^{1/3} \left[ \frac{9.8 \frac{\text{m}}{\text{s}^2} (957.9 - 0.5955) \frac{\text{kg}}{\text{m}^3}}{58.9 \times 10^{-3} \text{ N/m}} \right]^{1/6} \times \left( \frac{4217 \text{ J/kg}\cdot\text{K} \times 26 \text{ K}}{2257 \times 10^3 \text{ J/kg} \times 1.76} \right)$$

$$C_{s,f} = 0.017. \quad <$$

**COMMENTS:** By comparison with the values of  $C_{s,f}$  for other water-surface combinations of Table 10.1, the  $C_{s,f}$  value for the wire is large, suggesting that its surface must be highly polished. Note that the value of the boiling heat transfer coefficient is much larger than values common to single-phase convection.

## PROBLEM 10.6

**KNOWN:** Nucleate pool boiling on a 10 mm-diameter tube maintained at  $\Delta T_e = 10^\circ\text{C}$  in water at 1 atm; tube is platinum-plated.

**FIND:** Heat transfer coefficient.

**SCHEMATIC:**

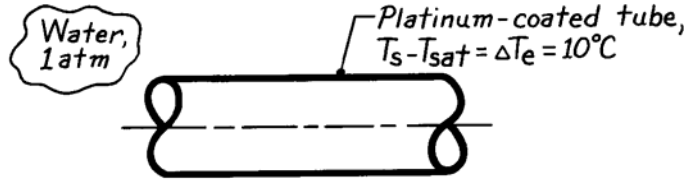

**ASSUMPTIONS:** (1) Steady-state conditions, (2) Nucleate pool boiling.

**PROPERTIES:** Table A-6, Water (saturated, 1 atm):  $T_s = 100^\circ\text{C}$ ,  $\rho_\ell = 1/v_f = 957.9 \text{ kg/m}^3$ ,  $\rho_v = 1/v_g = 0.5955 \text{ kg/m}^3$ ,  $c_{p,\ell} = 4217 \text{ J/kg}\cdot\text{K}$ ,  $\mu_\ell = 279 \times 10^{-6} \text{ N}\cdot\text{s/m}^2$ ,  $\text{Pr}_\ell = 1.76$ ,  $h_{fg} = 2257 \text{ kJ/kg}$ ,  $\sigma = 58.9 \times 10^{-3} \text{ N/m}$ .

**ANALYSIS:** The heat transfer coefficient can be estimated using the Rohsenow nucleate-boiling correlation and the rate equation

$$h = \frac{q_s''}{\Delta T_e} = \frac{\mu_\ell h_{fg}}{\Delta T_e} \left[ \frac{g(\rho_\ell - \rho_v)}{\sigma} \right]^{1/2} \left( \frac{c_{p,\ell} \Delta T_e}{C_{s,f} h_{fg} \text{Pr}_\ell^n} \right)^3.$$

From Table 10.1, find  $C_{s,f} = 0.013$  and  $n = 1$  for the water-platinum surface combination. Substituting numerical values,

$$h = \frac{279 \times 10^{-6} \text{ N}\cdot\text{s/m}^2 \times 2257 \times 10^3 \text{ J/kg}}{10 \text{ K}} \left[ \frac{9.8 \text{ m/s}^2 (957.9 - 0.5955) \text{ kg/m}^3}{58.9 \times 10^{-3} \text{ N/m}} \right]^{1/2} \times \left( \frac{4217 \text{ J/kg}\cdot\text{K} \times 10 \text{ K}}{0.013 \times 2257 \times 10^3 \text{ J/kg} \times 1.76} \right)^3$$

$$h = 13,690 \text{ W/m}^2 \cdot \text{K}.$$

<

**COMMENTS:** For this liquid-surface combination,  $q_s'' = 0.137 \text{ MW/m}^2$ , which is in general agreement with the *typical* boiling curve of Fig. 10.4. To a first approximation, the effect of the tube diameter is negligible.

## PROBLEM 10.7

**KNOWN:** Saturated water at 1 atm boiling on large, horizontal, polished copper plate.

**FIND:** Nucleate boiling heat flux over excess temperature range  $5^\circ\text{C} \leq \Delta T_e \leq 30^\circ\text{C}$ . Compare with Figure 10.4. Find excess temperature corresponding to critical heat flux.

**SCHEMATIC:**

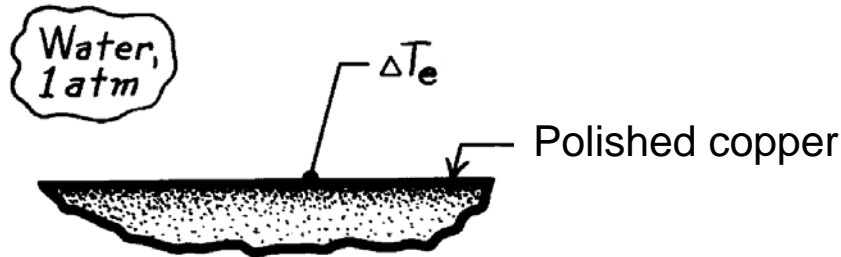

**ASSUMPTIONS:** (1) Steady-state conditions. (2) Nucleate pool boiling.

**PROPERTIES:** Table A-6, Saturated water (1 atm):  $T_{\text{sat}} = 100^\circ\text{C}$ ,  $\rho_\ell = 957.9 \text{ kg/m}^3$ ,  $\rho_v = 0.596 \text{ kg/m}^3$ ,  $c_{p,\ell} = 4217 \text{ J/kg}\cdot\text{K}$ ,  $\mu_\ell = 279 \times 10^{-6} \text{ N}\cdot\text{s/m}^2$ ,  $\text{Pr}_\ell = 1.76$ ,  $\sigma = 58.9 \times 10^{-3} \text{ N/m}$ ,  $h_{fg} = 2257 \text{ kJ/kg}$ .

**ANALYSIS:** The nucleate pool boiling heat flux can be estimated using the Rohsenow correlation.

$$q_s'' = \mu_\ell h_{fg} \left[ \frac{g(\rho_\ell - \rho_v)}{\sigma} \right]^{1/2} \left( \frac{c_{p,\ell} \Delta T_e}{C_{s,f} h_{fg} \text{Pr}_\ell^n} \right)^3$$

From Table 10.1, find for this liquid-surface combination,  $C_{s,f} = 0.0128$  and  $n = 1$ , and substituting numerical values,

$$q_s'' = 279 \times 10^{-6} \text{ N}\cdot\text{s/m}^2 \times 2257 \times 10^3 \text{ J/kg} \left[ \frac{9.8 \text{ m/s}^2 (957.9 - 0.596) \text{ kg/m}^3}{58.9 \times 10^{-3} \text{ N/m}} \right]^{1/2} \times \left( \frac{4217 \text{ J/kg}\cdot\text{K} \times \Delta T_e}{0.0128 \times 2257 \times 10^3 \text{ J/kg} \times 1.76} \right)^3$$

$$q_s'' = 143(\Delta T_e)^3 \text{ W/m}^2. \quad \leftarrow$$

This is plotted below.

Continued...

### PROBLEM 10.7 (Cont.)

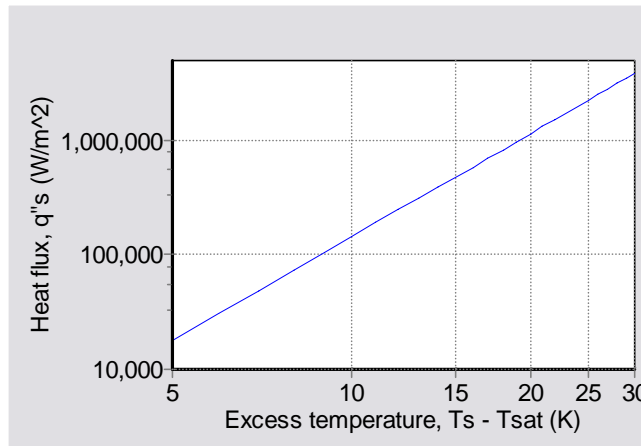

Compared with Figure 10.4, we see that this curve is a straight line on a log-log plot. The heat flux is higher than in Figure 10.4, especially for the higher values of excess temperature.

To find the excess temperature corresponding to the critical heat flux, we equate Eqs. (10.5) and (10.6) and solve for  $\Delta T_e$ .

$$\mu_\ell h_{fg} \left[ \frac{g(\rho_\ell - \rho_v)}{\sigma} \right]^{1/2} \left( \frac{c_{p,\ell} \Delta T_e}{C_{s,f} h_{fg} Pr_\ell^n} \right)^3 = Ch_{fg} \rho_v \left[ \frac{\sigma g(\rho_\ell - \rho_v)}{\rho_v^2} \right]^{1/4}$$

$$\Delta T_e = \frac{C_{s,f} h_{fg} Pr_\ell^n}{c_{p,\ell}} \left\{ Ch_{fg} \rho_v \left[ \frac{\sigma g(\rho_\ell - \rho_v)}{\rho_v^2} \right]^{1/4} \middle/ \left( \mu_\ell h_{fg} \left[ \frac{g(\rho_\ell - \rho_v)}{\sigma} \right]^{1/2} \right) \right\}^{1/3}$$

where  $C = 0.149$  for a large horizontal plate. Substituting numbers we find

$$\Delta T_e = 20.6^\circ\text{C}$$

<

**COMMENTS:** (1) The correlation and Figure 10.4 do not agree extremely well. The error is worst near ONB (70% error at  $\Delta T_e = 5^\circ\text{C}$ ) and CHF (170% error at  $\Delta T_e = 30^\circ\text{C}$ ). Since the correlation is a straight line on a log-log plot, it doesn't reproduce the curvature at the two ends of the curve. Since the correlation isn't accurate near CHF, it does not do an excellent job of predicting  $\Delta T_e$ , which appears to be around  $30^\circ\text{C}$  from Figure 10.4. (2) Figure 10.4 is a *typical* boiling curve. The boiling curve will shift as different boiling surfaces and geometries (and, in turn, different values of  $C_{s,f}$ ) are considered.

## PROBLEM 10.8

**KNOWN:** Simple expression to account for the effect of pressure on the nucleate boiling convection coefficient in water.

**FIND:** Compare predictions of this expression with the Rohsenow correlation for specified  $\Delta T_e$  and pressures (2 and 5 bar) applied to a horizontal plate.

**ASSUMPTIONS:** (1) Steady-state conditions, (2) Nucleate pool boiling, (3)  $C_{s,f} = 0.013$ ,  $n = 1$ .

**PROPERTIES:** Table A-6, Saturated water (2 bar):  $\rho_\ell = 942.7 \text{ kg/m}^3$ ,  $c_{p,\ell} = 4244.3 \text{ J/kg}\cdot\text{K}$ ,  $\mu_\ell = 230.7 \times 10^{-6} \text{ N}\cdot\text{s/m}^2$ ,  $\text{Pr}_\ell = 1.43$ ,  $h_{fg} = 2203 \text{ kJ/kg}$ ,  $\sigma = 54.97 \times 10^{-3} \text{ N/m}$ ,  $\rho_v = 1.1082 \text{ kg/m}^3$ ;  
Saturated water (5 bar):  $\rho_\ell = 914.7 \text{ kg/m}^3$ ,  $c_{p,\ell} = 4316 \text{ J/kg}\cdot\text{K}$ ,  $\mu_\ell = 179 \times 10^{-6} \text{ N}\cdot\text{s/m}^2$ ,  $\text{Pr}_\ell = 1.13$ ,  $h_{fg} = 2107.8 \text{ kJ/kg}$ ,  $\sigma = 48.4 \times 10^{-3} \text{ N/m}$ ,  $\rho_v = 2.629 \text{ kg/m}^3$ .

**ANALYSIS:** The simple expression by Jakob accounting for pressure effects is

$$h = C(\Delta T_e)^n (p/p_a)^{0.4} \quad (1)$$

where  $p$  and  $p_a$  are the system and standard atmospheric pressures. For a horizontal plate,  $C = 5.56$  and  $n = 3$  for the range  $15 < q_s'' < 235 \text{ kW/m}^2$ . For  $\Delta T_e = 10^\circ\text{C}$ ,

$$p = 2 \text{ bar} \quad h = 5.56(10)^3 (2 \text{ bar}/1.0133 \text{ bar})^{0.4} = 7,298 \text{ W/m}^2 \cdot \text{K}, \quad q_s'' = 73 \text{ kW/m}^2 <$$

$$p = 5 \text{ bar} \quad h = 5.56(10)^3 (5 \text{ bar}/1.0133 \text{ bar})^{0.4} = 10,529 \text{ W/m}^2 \cdot \text{K}, \quad q_s'' = 105 \text{ kW/m}^2 <$$

where  $q_s'' = h\Delta T_e$ . The Rohsenow correlation, Eq. 10.5, with  $C_{s,f} = 0.013$  and  $n = 1$ , is of the form

$$q_s'' = \mu_\ell h_{fg} \left[ \frac{g(\rho_\ell - \rho_v)}{\sigma} \right]^{1/2} \left[ \frac{c_{p,\ell} \Delta T_e}{C_{s,f} h_{fg} \text{Pr}_\ell^n} \right]^3 \quad (2)$$

$$p = 2 \text{ bar}: \quad q_s'' = 230.7 \times 10^{-6} \frac{\text{N}\cdot\text{s}}{\text{m}^2} \times 2203 \times 10^3 \frac{\text{J}}{\text{kg}} \left[ \frac{9.8 \frac{\text{m}}{\text{s}^2} (942.7 - 1.1082) \frac{\text{kg}}{\text{m}^3}}{54.97 \times 10^{-3} \text{ N/m}} \right]^{1/2} \times \left[ \frac{4244.3 \text{ J/kg}\cdot\text{K} \times 10 \text{ K}}{0.013 \times 2203 \times 10^3 \frac{\text{J}}{\text{kg}} \times 1.43^1} \right]^3$$

$$q_s'' = 232 \text{ kW/m}^2 <$$

$$p = 5 \text{ bar}: \quad q_s'' = 439 \text{ kW/m}^2 <$$

**COMMENTS:** For ease of comparison, the results with  $p_a = 1.0133 \text{ bar}$  are:

	$q_s'' \left( \text{kW/m}^2 \right)$		
Correlation/p (bar)	1	2	4
Simple	56	73	105
Rohsenow	135	232	439

Note that the range of  $q_s''$  is within the limits of the Simple correlation. The comparison is poor and therefore the correlation is not to be recommended. By manipulation of the Rohsenow results, find that the  $(p/p_o)^m$  dependence provides  $m \approx 0.75$ , compared to the exponent of 0.4 in the Simple correlation.

## PROBLEM 10.9

**KNOWN:** Diameter of copper pan. Initial temperature of water and saturation temperature of boiling water. Range of heat rates ( $1 \leq q \leq 100 \text{ kW}$ ).

**FIND:** (a) Variation of pan temperature with heat rate for boiling water, (b) Pan temperature shortly after start of heating with  $q = 8 \text{ kW}$ .

**SCHEMATIC:**

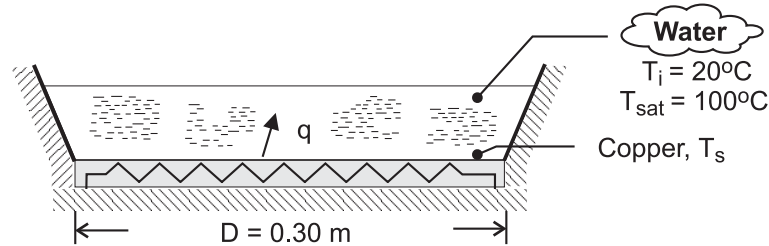

**ASSUMPTIONS:** (1) Conditions of part (a) correspond to steady nucleate boiling, (2) Surface of pan corresponds to polished copper, (3) Conditions of part (b) correspond to natural convection from a heated plate to an infinite quiescent medium, (4) Negligible heat loss to surroundings.

**PROPERTIES:** Table A-6, saturated water ( $T_{\text{sat}} = 100^\circ\text{C}$ ):  $\rho_\ell = 957.9 \text{ kg/m}^3$ ,  $\rho_v = 0.60 \text{ kg/m}^3$ ,

$c_{p,\ell} = 4217 \text{ J/kg}\cdot\text{K}$ ,  $\mu_\ell = 279 \times 10^{-6} \text{ N}\cdot\text{s/m}^2$ ,  $\text{Pr}_\ell = 1.76$ ,  $h_{fg} = 2.257 \times 10^6 \text{ J/kg}$ ,  $\sigma = 0.0589 \text{ N/M}$ .

Table A-6, saturated water (assume  $T_s = 100^\circ\text{C}$ ,  $T_f = 60^\circ\text{C} = 333 \text{ K}$ ):  $\rho = 983 \text{ kg/m}^3$ ,  $\mu = 467 \times 10^{-6} \text{ N}\cdot\text{s/m}^2$ ,  $k = 0.654 \text{ W/m}\cdot\text{K}$ ,  $\text{Pr} = 2.99$ ,  $\beta = 523 \times 10^{-6} \text{ K}^{-1}$ . Hence,  $\nu = 0.475 \times 10^{-6} \text{ m}^2/\text{s}$ ,  $\alpha = 0.159 \times 10^{-6} \text{ m}^2/\text{s}$ .

**ANALYSIS:** (a) From Eq. (10.5),

$$\Delta T_e = T_s - T_{\text{sat}} = \frac{C_{s,f} h_{fg} \text{Pr}_\ell^n}{c_{p,\ell}} \times \left\{ \frac{q_s / \mu_\ell h_{fg} A_s}{[g(\rho_\ell - \rho_v) / \sigma]^{1/2}} \right\}^{1/3}$$

For  $n = 1.0$ ,  $C_{s,f} = 0.0128$  and  $A_s = \pi D^2/4 = 0.0707 \text{ m}^2$ , the following variation of  $T_s$  with  $q_s$  is obtained.

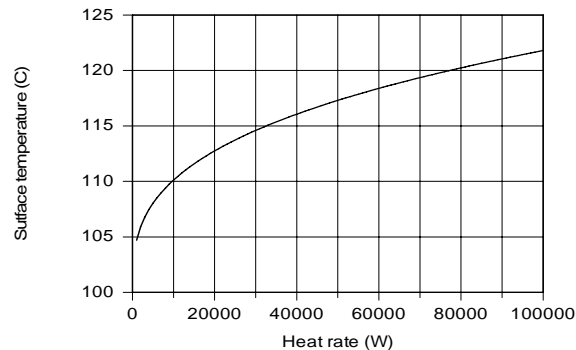

As indicated by the correlation, the surface temperature increases as the cube root of the heat rate, permitting large increases in  $q$  for modest changes in  $T_s$ . For  $q = 1 \text{ kW}$ ,  $T_s = 104.7^\circ\text{C}$ , which is barely sufficient to sustain boiling.

(b) Assuming  $10^7 < \text{Ra}_L < 10^{11}$ , the convection coefficient may be obtained from Eq. (9.31). Hence, with  $L = A_s/P = D/4 = 0.075 \text{ m}$ ,

Continued ...



**PROBLEM 10.9 (Cont.)**

$$\begin{aligned}\bar{h} &= \left(\frac{k}{L}\right) 0.15 \text{Ra}_L^{1/3} = \left(\frac{0.654 \text{ W/m}\cdot\text{K}}{0.075 \text{ m}}\right) 0.15 \left[ \frac{9.8 \text{ m/s}^2 \times 523 \times 10^{-6} \text{ K}^{-1} (T_s - T_i) (0.075 \text{ m})^3}{0.475 \times 0.159 \times 10^{-12} \text{ m}^4/\text{s}^2} \right]^{1/3} \\ &= 1.308 \left(2.86 \times 10^7\right)^{1/3} (T_s - T_i)^{1/3} = 400 (T_s - T_i)^{1/3}\end{aligned}$$

With  $A_s = \pi D^2/4 = 0.0707 \text{ m}^2$ , the heat rate is then

$$q = \bar{h} A_s (T_s - T_i) = \left(400 \text{ W/m}^2 \cdot \text{K}^{4/3}\right) 0.0707 \text{ m}^2 (T_s - T_i)^{4/3}$$

With  $q = 8000 \text{ W}$ ,

$$T_s = T_i + 69^\circ\text{C} = 89^\circ\text{C}$$

<

**COMMENTS:** (1) With  $(T_s - T_i) = 69^\circ\text{C}$ ,  $\text{Ra}_L = 1.97 \times 10^9$ , which is within the assumed Rayleigh number range. (2) The surface temperature increases as the temperature of the water increases, and bubbles may nucleate when it exceeds  $100^\circ\text{C}$ . However, while the water temperature remains below the saturation temperature, the bubbles will collapse in the subcooled liquid.

## PROBLEM 10.10

**KNOWN:** Fluids at 1 atm: mercury, ethanol, R-134a.

**FIND:** Critical heat flux; compare with value for water also at 1 atm.

**ASSUMPTIONS:** (1) Steady-state conditions, (2) Nucleate pool boiling.

**PROPERTIES:** Table A-5 and Table A-6 at 1 atm,

	$h_{fg}$ (kJ/kg)	$\rho_v$ (kg/m <sup>3</sup> )	$\rho_l$ (kg/m <sup>3</sup> )	$\sigma \times 10^3$ (N/m)	$T_{sat}$ (K)
Mercury	301	3.90	12,740	417	630
Ethanol	846	1.44	757	17.7	351
R-134a	217	5.26	1,377	15.4	247
Water	2257	0.596	957.9	58.9	373

**ANALYSIS:** The critical heat flux can be estimated by Eq. 10.6 with  $C = 0.149$ ,

$$q''_{max} = 0.149 h_{fg} \rho_v \left[ \frac{\sigma g (\rho_l - \rho_v)}{\rho_v^2} \right]^{1/4}.$$

To illustrate the calculation procedure, consider numerical values for *mercury*.

$$q''_{max} = 0.149 \times 301 \times 10^3 \text{ J/kg} \times 3.90 \text{ kg/m}^3 \times \left[ \frac{417 \times 10^{-3} \text{ N/m} \times 9.8 \text{ m/s}^2 (12,740 - 3.90) \text{ kg/m}^3}{(3.90 \text{ kg/m}^3)^2} \right]^{1/4}$$

$$q''_{max} = 1.34 \text{ MW/m}^2.$$

For the other fluids, the results are tabulated along with the ratio of the critical heat fluxes to that for water.

Fluid	$q''_{max}$ (MW/m <sup>2</sup> )	$q''_{max} / q''_{max, water}$
Mercury	1.34	1.06
Ethanol	0.512	0.41
R-134a	0.281	0.22
Water	1.26	1.00

**COMMENTS:** Note that, despite the large difference between mercury and water properties, their critical heat fluxes are similar.

## PROBLEM 10.11

**KNOWN:** Water at atmospheric pressure boiling on horizontal copper tube. Heat flux is 90% of critical value.

**FIND:** Tube surface temperature under scored conditions and conditions similar to a polished surface.

**SCHEMATIC:**

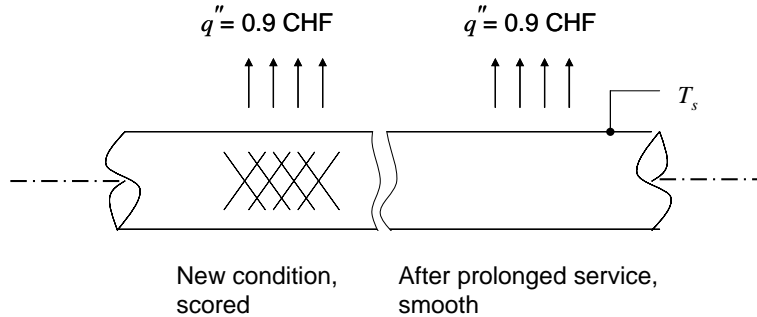

**ASSUMPTIONS:** (1) Steady-state, (2) Uniform tube wall temperature, (3) Nucleate boiling at outer surface of tube, (4) Constant properties.

**PROPERTIES:** Table A-6, Water ( $T = 373 \text{ K}$ ):  $\rho_l = 957.9 \text{ kg/m}^3$ ,  $\rho_v = 0.596 \text{ kg/m}^3$ ,  $h_{fg} = 2257 \text{ kJ/kg}$ ,  $c_{p,l} = 4.217 \text{ kJ/kg}\cdot\text{K}$ ,  $\mu_l = 279 \times 10^{-6} \text{ N}\cdot\text{s/m}^2$ ,  $k_l = 0.680 \text{ W/m}\cdot\text{K}$ ,  $Pr_l = 1.76$ ,  $\sigma = 58.9 \times 10^{-3} \text{ N/m}$ .

**ANALYSIS:** The heat flux is 90% of the critical heat flux given by Eq. 10.6, thus with  $C = 0.131$  for a large horizontal tube,

$$\begin{aligned}
 q_s'' &= 0.9 C h_{fg} \rho_v \left[ \frac{\sigma g (\rho_l - \rho_v)}{\rho_v^2} \right]^{1/4} = 0.9 \times 0.131 \times 2257 \times 10^3 \text{ J/kg} \times 0.596 \text{ kg/m}^3 \\
 &\times \left[ \frac{58.9 \times 10^{-3} \text{ N/m} \times 9.8 \text{ m/s}^2 \times (957.9 \text{ kg/m}^3 - 0.596 \text{ kg/m}^3)}{(0.596 \text{ kg/m}^3)^2} \right]^{1/4} \\
 &= 9.96 \times 10^5 \text{ W/m}^2
 \end{aligned}$$

The nucleate boiling heat flux is given by Eq. 10.5, with  $C_{s,f} = 0.0068$ ,  $n = 1.0$  for a scored copper surface. Solving for the excess temperature,

$$\begin{aligned}
 \Delta T_e &= \frac{C_{s,f} h_{fg} Pr_l^n}{c_{p,l}} \left\{ \frac{q_s''}{\mu_l h_{fg}} \left[ \frac{\sigma}{g (\rho_l - \rho_v)} \right]^{1/2} \right\}^{1/3} = \frac{0.0068 \times 2257 \times 10^3 \text{ J/kg} \times 1.76}{4217 \text{ J/kg}\cdot\text{K}} \\
 &\times \left\{ \frac{9.96 \times 10^5 \text{ W/m}^2}{279 \times 10^{-6} \text{ N}\cdot\text{s/m}^2 \times 2257 \times 10^3 \text{ J/kg}} \left[ \frac{58.9 \times 10^{-3} \text{ N/m}}{9.8 \text{ m/s}^2 (957.9 - 0.596) \text{ kg/m}^3} \right]^{1/2} \right\}^{1/3} \\
 &= 10.1^\circ\text{C}
 \end{aligned}$$

Thus, for the scored surface

$$T_s = \Delta T_e + T_{\text{sat}} = 10.1^\circ\text{C} + 100^\circ\text{C} = 110.1^\circ\text{C}$$

<

Continued...

### PROBLEM 10.11 (Cont.)

After the surface degrades to conditions similar to a polished surface, the value of  $C_{s,f}$  becomes 0.0128. Recognizing that  $\Delta T_e$  is proportional to  $C_{s,f}$ ,  $\Delta T_e = 10.1^\circ\text{C}(0.0128/0.0068) = 19.1^\circ\text{C}$ . Hence, after prolonged service,

$$T_s = \Delta T_e + T_{\text{sat}} = 19.1^\circ\text{C} + 100^\circ\text{C} = 119.1^\circ\text{C}$$

&lt;

**COMMENTS:** (1) A scored surface provides nucleation sites that enhance nucleate boiling, resulting in a smaller excess temperature relative to a smooth surface, for the same heat flux.

## PROBLEM 10.12

**KNOWN:** Copper pan, 150 mm diameter and filled with water at 1 atm, is maintained at 115°C.

**FIND:** Power required to boil water and the evaporation rate; ratio of heat flux to critical heat flux; pan temperature required to achieve critical heat flux.

**SCHEMATIC:**

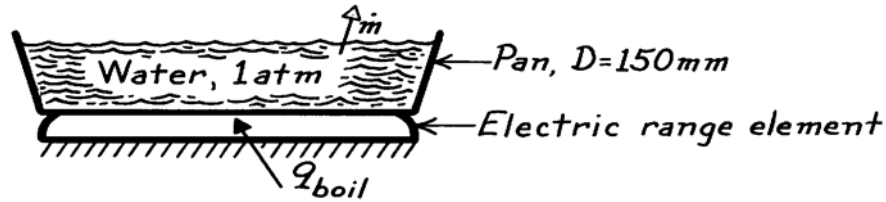

**ASSUMPTIONS:** (1) Nucleate pool boiling, (2) Copper pan is polished surface.

**PROPERTIES:** Table A-6, Water (1 atm):  $T_{\text{sat}} = 100^\circ\text{C}$ ,  $\rho_\ell = 957.9\text{ kg/m}^3$ ,  $\rho_v = 0.5955\text{ kg/m}^3$ ,  $c_{p,\ell} = 4217\text{ J/kg}\cdot\text{K}$ ,  $\mu_\ell = 279 \times 10^{-6}\text{ N}\cdot\text{s/m}^2$ ,  $\text{Pr}_\ell = 1.76$ ,  $h_{\text{fg}} = 2257\text{ kJ/kg}$ ,  $\sigma = 58.9 \times 10^{-3}\text{ N/m}$ .

**ANALYSIS:** The power requirement for boiling and the evaporation rate can be expressed as follows,

$$q_{\text{boil}} = q_s'' \cdot A_s \quad \dot{m} = q_{\text{boil}} / h_{\text{fg}}$$

The heat flux for nucleate pool boiling can be estimated using the Rohsenow correlation.

$$q_s'' = \mu_\ell h_{\text{fg}} \left[ \frac{g(\rho_\ell - \rho_v)}{\sigma} \right]^{1/2} \left( \frac{c_{p,\ell} \Delta T_e}{C_{s,f} h_{\text{fg}} \text{Pr}_\ell^n} \right)^3$$

Selecting  $C_{s,f} = 0.0128$  and  $n = 1$  from Table 10.1 for the polished copper finish, find

$$q_s'' = 279 \times 10^{-6} \frac{\text{N}\cdot\text{s}}{\text{m}^2} \times 2257 \times 10^3 \frac{\text{J}}{\text{kg}} \left[ \frac{9.8 \frac{\text{m}}{\text{s}^2} (957.9 - 0.5955) \frac{\text{kg}}{\text{m}^3}}{58.9 \times 10^{-3} \text{ N/m}} \right]^{1/2} \left( \frac{4217 \frac{\text{J}}{\text{kg}\cdot\text{K}} \times 15^\circ\text{C}}{0.0128 \times 2257 \times 10^3 \frac{\text{J}}{\text{kg}} \times 1.76} \right)^3$$

$$q_s'' = 4.839 \times 10^5 \text{ W/m}^2$$

The power and evaporation rate are

$$q_{\text{boil}} = 4.839 \times 10^5 \text{ W/m}^2 \times \frac{\pi}{4} (0.150\text{ m})^2 = 8.55 \text{ kW} \quad <$$

$$\dot{m}_{\text{boil}} = 8.55 \text{ kW} / 2257 \times 10^3 \text{ J/kg} = 3.79 \times 10^{-3} \text{ kg/s} = 14 \text{ kg/h} \quad <$$

The maximum or critical heat flux was found in Example 10.1 as

$$q_{\text{max}}'' = 1.26 \text{ MW/m}^2$$

Hence, the ratio of the operating to maximum heat flux is

$$\frac{q_s''}{q_{\text{max}}''} = 4.619 \times 10^5 \text{ W/m}^2 / 1.26 \text{ MW/m}^2 = 0.384 \quad <$$

From the boiling curve, Fig. 10.4,  $\Delta T_e \approx 30^\circ\text{C}$  will provide the maximum heat flux. <

### PROBLEM 10.13

**KNOWN:** Nickel-coated heater element exposed to saturated water at atmospheric pressure; thermocouple attached to the insulated, backside surface indicates a temperature  $T_o = 266.4^\circ\text{C}$  when the electrical power dissipation in the heater element is  $6.950 \times 10^7 \text{ W/m}^3$ .

**FIND:** (a) From the foregoing data, calculate the surface temperature,  $T_s$ , and the heat flux at the exposed surface, and (b) Using an appropriate boiling correlation, estimate the surface temperature based upon the surface heat flux determined in part (a).

**SCHEMATIC:**

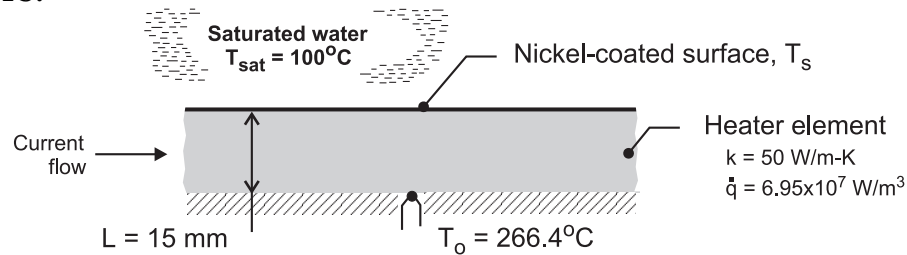

**ASSUMPTIONS:** (1) Steady-state conditions, (2) Water exposed to standard atmospheric pressure and uniform temperature,  $T_{\text{sat}}$ , and (3) Nucleate pool boiling occurs on exposed surface, (4) Uniform volumetric generation in element, and (5) Backside of heater is perfectly insulated.

**PROPERTIES:** Table A-6, Saturated water, liquid ( $100^\circ\text{C}$ ):  $\rho_\ell = 1/v_f = 957.9 \text{ kg/m}^3$ ,  $c_{p,\ell} = c_{p,f} = 4.217 \text{ kJ/kg}\cdot\text{K}$ ,  $\mu_\ell = \mu_f = 279 \times 10^{-6} \text{ N}\cdot\text{s/m}^2$ ,  $\text{Pr}_\ell = \text{Pr}_f = 1.76$ ,  $h_{fg} = 2257 \text{ kJ/kg}$ ,  $\sigma = 58.9 \times 10^{-3} \text{ N/m}$ ; Saturated water, vapor ( $100^\circ\text{C}$ ):  $\rho_v = 1/v_g = 0.5955 \text{ kg/m}^3$ .

**ANALYSIS:** (a) From Eq. 3.58, the temperature at the exposed surface,  $T_s$ , is

$$T_s = T_o - \frac{\dot{q}L^2}{2k} = 266.4^\circ\text{C} - \frac{6.95 \times 10^7 \text{ W/m}^3 (0.015 \text{ m})^2}{2 \times 50 \text{ W/m}\cdot\text{K}}$$

$$T_s = 110.0^\circ\text{C} \quad <$$

The heat flux at the exposed surface is

$$q_s'' = \dot{q}L = 6.95 \times 10^7 \text{ W/m}^3 \times 0.015 \text{ m} = 1.043 \times 10^6 \text{ W/m}^2 \quad <$$

(b) Since  $\Delta T_e = T_s - T_{\text{sat}} = (110 - 100)^\circ\text{C} = 10^\circ\text{C}$ , nucleate pool boiling occurs and the Rohsenow correlation, Eq. 10.5, with  $q_s''$  from part (a) can be used to estimate the surface temperature,  $T_{s,c}$ ,

$$q_s'' = \mu_\ell h_{fg} \left[ \frac{g(\rho_\ell - \rho_v)}{\sigma} \right]^{1/2} \left( \frac{c_{p,\ell} \Delta T_{e,c}}{C_{s,f} h_{fg} \text{Pr}_\ell^n} \right)^3$$

From Table 10.1, for the water-nickel surface-fluid combination,  $C_{s,f} = 0.006$  and  $n = 1.0$ .

Substituting numerical values, find  $\Delta T_{e,c}$  and  $T_{s,c}$ .

Continued ...

**PROBLEM 10.13 (Cont.)**

$$1.043 \times 10^6 \text{ W/m}^2 = 279 \times 10^{-6} \text{ N} \cdot \text{s/m}^2 \times 2257 \times 10^3 \text{ J/kg}$$

$$\times \left[ \frac{9.8 \text{ m/s}^2 (957.9 - 0.5955) \text{ kg/m}^3}{58.9 \times 10^{-3} \text{ N/m}} \right]^{1/2}$$

$$\times \left( \frac{4.217 \times 10^3 \text{ J/kg} \cdot \text{K} \times \Delta T_{e,c}}{0.006 \times 2257 \times 10^3 \text{ J/kg} \times 1.76} \right)^3$$

$$\Delta T_{e,c} = T_{s,c} - T_{\text{sat}} = 9.1^\circ\text{C}$$

$$T_{s,c} = 109.1^\circ\text{C}$$

<

**COMMENTS:** From the experimental data, part (a), the surface temperature is determined from the conduction analysis as  $T_s = 110.0^\circ\text{C}$ . Using the traditional nucleate boiling correlation with the experimental value for the heat flux, the surface temperature is estimated as  $T_{s,c} = 109.1^\circ\text{C}$ . The two approaches provide excess temperatures that are 10.0 vs. 9.1°C, which amounts to nearly a 10% difference.

## PROBLEM 10.14

**KNOWN:** Chips on a ceramic substrate operating at power levels corresponding to 50% of the critical heat flux.

**FIND:** (a) Chip power level and temperature rise of the chip surface, and (b) Compute and plot the chip temperature  $T_s$  as a function of heat flux for the range  $0.25 \leq q_s''/q_{s,\text{max}}'' \leq 0.90$ .

**SCHEMATIC:**

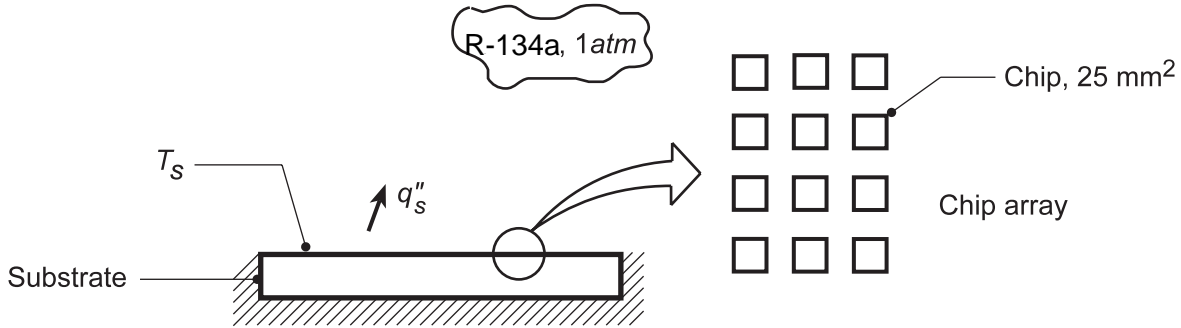

**ASSUMPTIONS:** (1) Nucleate boiling, (2) Fluid-surface with  $C_{s,f} = 0.004$ ,  $n = 1.7$  for Rohsenow correlation, (3) Backside of substrate insulated.

**PROPERTIES:** Table A-5, Refrigerant R-134a (1 atm):  $T_{\text{sat}} = 247 \text{ K} = -26^\circ\text{C}$ ,  $\rho_\ell = 1377 \text{ kg/m}^3$ ,  $\rho_v = 5.26 \text{ kg/m}^3$ ,  $h_{fg} = 217 \text{ kJ/kg}$ ,  $\sigma = 15.4 \times 10^{-3} \text{ N/m}$ ; R-134a, sat. liquid (given, 247 K):  $c_{p,\ell} = 1551 \text{ J/kg}\cdot\text{K}$ ,  $\mu_\ell = 1.46 \times 10^{-4} \text{ N}\cdot\text{s/m}^2$ ,  $\text{Pr}_\ell = 3.2$ .

**ANALYSIS:** (a) The operating power level (flux) is  $0.50 q_{s,\text{max}}''$ , where the critical heat flux is estimated from Eq. 10.6 with  $C=0.149$  for nucleate pool boiling,

$$q_{s,\text{max}}'' = 0.149 h_{fg} \rho_v \left[ \frac{\sigma g (\rho_\ell - \rho_v)}{\rho_v^2} \right]^{1/4}$$

$$q_{s,\text{max}}'' = 0.149 \times 217 \times 10^3 \frac{\text{J}}{\text{kg}} \times 5.26 \frac{\text{kg}}{\text{m}^3} \left[ \frac{15.4 \times 10^{-3} \frac{\text{N}}{\text{m}} \times 9.8 \frac{\text{m}}{\text{s}^2} (1377 - 5.26) \frac{\text{kg}}{\text{m}^3}}{\left( 5.26 \frac{\text{kg}}{\text{m}^3} \right)^2} \right]^{1/4}$$

$$q_{s,\text{max}}'' = 281 \text{ kW/m}^2.$$

Hence, the heat flux on a chip is  $0.5 \times 281 \text{ kW/m}^2 = 141 \text{ kW/m}^2$  and the power level is

$$q_{\text{chip}} = q_s'' \times A_s = 141 \times 10^3 \text{ W/m}^2 \times 25 \text{ mm}^2 \left( 10^{-3} \text{ m/mm} \right)^2 = 3.5 \text{ W}. \quad <$$

To determine the chip surface temperature for this condition, use the Rohsenow equation to find  $\Delta T_e = T_s - T_{\text{sat}}$  with  $q_s'' = 141 \times 10^3 \text{ W/m}^2$ . The correlation, Eq. 10.5, solved for  $\Delta T_e$  is

$$\Delta T_e = \frac{C_{s,f} h_{fg} \text{Pr}_\ell^n}{c_{p,\ell}} \left( \frac{q_s''}{\mu_\ell h_{fg}} \right)^{1/3} \left[ \frac{\sigma}{g (\rho_\ell - \rho_v)} \right]^{1/6} = \frac{0.004 \times 217 \times 10^3 \text{ J/kg} (3.2)^{1.7}}{1551 \text{ J/kg}\cdot\text{K}} \times$$

$$\left( \frac{141 \times 10^3 \text{ W/m}^2}{1.46 \times 10^{-4} \frac{\text{N}\cdot\text{s}}{\text{m}^2} \times 217 \times 10^3 \frac{\text{J}}{\text{kg}}} \right)^{1/3} \left[ \frac{15.4 \times 10^{-3} \text{ N/m}}{9.8 \frac{\text{m}}{\text{s}^2} (1377 - 5.26) \frac{\text{kg}}{\text{m}^3}} \right]^{1/6} = 6.8^\circ\text{C}.$$

Hence, the chip surface temperature is

Continued...



### PROBLEM 10.14 (Cont.)

$$T_s = T_{\text{sat}} + \Delta T_e = -26^\circ\text{C} + 6.8^\circ\text{C} \approx -19^\circ\text{C}$$

<

(b) Using the *IHT Correlations Tools, Boiling, Nucleate Pool Boiling -- Heat flux and Maximum heat flux*, the chip surface temperature,  $T_s$ , was calculated as a function of the ratio  $q''_s/q''_{\text{max}}$ . The required thermophysical properties as provided in the problem statement were entered directly into the IHT workspace. The results are plotted below.

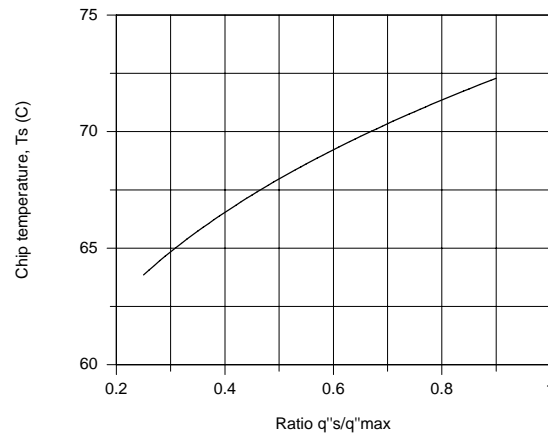

**COMMENTS:** (1) A copy of the *IHT Workspace* model used to generate the above plot is shown below.

```

// Correlations Tool – Boiling, Nucleate pool boiling, Critical heat flux
q''max = qmax_dprime_NPB(C,rhol,rhov,hfg,sigma,g) // Eq 10.6
g = 9.8 // Gravitational constant, m/s^2
// Evaluate liquid(l) and vapor(v) properties at Tsat.
// C = 0.131 for large horizontal cylinders and spheres
// C = 0.149 for large horizontal plates
C = 0.149
/* Correlation description: Critical (maximum) heat flux for nucleate pool boiling (NPB). Eq 10.6,
C=0.131 or 0.149 depending on geometry. See boiling curve, Fig 10.4 . */
// Correlations Tool – Boiling, Nucleate pool boiling, Heat flux
q''s = qs_dprime_NPB(Csf,n,rhol,rhov,hfg,cpl,mul,Prl,sigma,deltaTe,g) // Eq 10.5
//g = 9.8 // gravitational constant, m/s^2
deltaTe = Ts - Tsat // excess temperature, K
Tsat = 247 // saturation temperature, K
/* Evaluate liquid(l) and vapor(v) properties at Tsat. From Table 10.1 (Fill in as required), */
// fluid-surface combination:
Csf = 0.004 // Given
n = 1.7 // Given
/* Correlation description: Heat flux for nucleate pool boiling (NPB), water-surface combination
(Cf,n), Eq 10.5, Table 10.1 . See boiling curve, Fig 10.4 . */
// Heat rates:
qsqm = q''s / q''max // Ratio, heat flux over critical heat flux
qsqm = 0.5
// Thermophysical properties (given):
rhol = 1377 // Density, liquid, kg/m^3
rhov = 5.26 // Density, vapor, kg/m^3
hfg = 217000 // Heat of vaporization, J/kg
sigma = 15.4e-3 // Surface tension, N/m
cpl = 1551 // Specific heat, saturated liquid, J/kg.K
mul = 1.46e-4 // Viscosity, saturated liquid, N.s/m^2
Prl = 3.2 // Prandtl number, saturated liquid

```

### PROBLEM 10.15

**KNOWN:** Saturated ethylene glycol at 1 atm heated by a chromium-plated heater of 200 mm diameter and maintained at 480K.

**FIND:** Heater power, rate of evaporation, and ratio of required power to maximum power for critical heat flux.

**SCHEMATIC:**

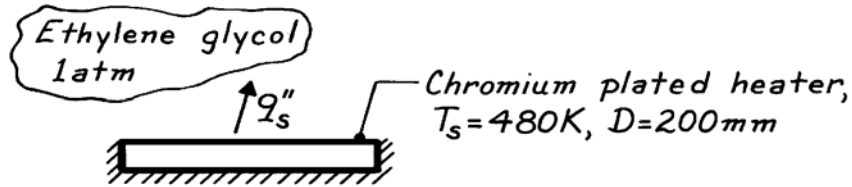

**ASSUMPTIONS:** (1) Nucleate pool boiling, (2) Fluid-surface,  $C_{s,f} = 0.010$  and  $n = 1$ .

**PROPERTIES:** Table A-5, Saturated ethylene glycol (1 atm):  $T_{sat} = 470\text{K}$ ,  $h_{fg} = 812\text{ kJ/kg}$ ,  $\rho_f = 1111\text{ kg/m}^3$ ,  $\sigma = 32.7 \times 10^{-3}\text{ N/m}$ ; Saturated ethylene glycol (given, 470K):  $\rho_v = 1.66\text{ kg/m}^3$ ,  $\mu_\ell = 0.38 \times 10^{-3}\text{ N}\cdot\text{s/m}^2$ ,  $c_{p,\ell} = 3280\text{ J/kg}\cdot\text{K}$ ,  $Pr_\ell = 8.7$ .

**ANALYSIS:** The power requirement for boiling and the evaporation rate are  $q_{boil} = q_s'' \cdot A_s$  and  $\dot{m} = q_{boil} / h_{fg}$ . Using the Rohsenow correlation,

$$q_s'' = \mu_\ell h_{fg} \left[ \frac{g(\rho_\ell - \rho_v)}{\sigma} \right]^{1/2} \left( \frac{c_{p,\ell} \Delta T_e}{C_{s,f} h_{fg} Pr_\ell^n} \right)^3$$

$$q_s'' = 0.38 \times 10^{-3} \frac{\text{N}\cdot\text{s}}{\text{m}^2} \times 812 \times 10^3 \frac{\text{J}}{\text{kg}} \left[ \frac{9.8\text{ m/s}^2 (1111 - 1.66)\text{ kg/m}^3}{32.7 \times 10^{-3}\text{ N/m}} \right]^{1/2} \left( \frac{3280\text{ J/kg}\cdot\text{K} (480 - 470)\text{ K}}{0.01 \times 812 \times 10^3 \frac{\text{J}}{\text{kg}} (8.7)^1} \right)^3$$

$$q_s'' = 1.78 \times 10^4\text{ W/m}^2 \quad q_{boil} = 1.78 \times 10^4\text{ W/m}^2 \times \pi/4 (0.200\text{ m})^2 = 559\text{ W} \quad <$$

$$\dot{m} = 559\text{ W} / 812 \times 10^3\text{ J/kg} = 6.89 \times 10^{-4}\text{ kg/s.} \quad <$$

For this fluid, the critical heat flux is estimated from Eq. 10.6 with  $C=0.149$ ,

$$q_{max}'' = 0.149 h_{fg} \rho_v \left[ \sigma g (\rho_\ell - \rho_v) / \rho_v^2 \right]^{1/4}$$

$$q_{max}'' = 0.149 \times 812 \times 10^3 \frac{\text{J}}{\text{kg}} \times 1.66 \frac{\text{kg}}{\text{m}^3} \left[ \frac{32.7 \times 10^{-3}\text{ N/m} \times 9.8\text{ m/s}^2 (1111 - 1.66)\text{ kg/m}^3}{(1.66\text{ kg/m}^3)^2} \right]^{1/4}$$

$$q_{max}'' = 6.77 \times 10^5\text{ W/m}^2.$$

Hence, the ratio of the operating heat flux to the critical heat flux is,

$$\frac{q_s''}{q_{max}''} = \frac{1.78 \times 10^4\text{ W/m}^2}{6.77 \times 10^5\text{ W/m}^2} \approx 0.026 \quad \text{or} \quad 2.6\%. \quad <$$

**COMMENTS:** Recognize that the results are crude approximations since the values for  $C_{s,f}$  and  $n$  are just estimates. This fluid is not normally used for boiling processes since it decomposes at higher temperatures.

## PROBLEM 10.16

**KNOWN:** Copper tubes, 25 mm diameter  $\times$  0.75 m long, used to boil saturated water at 1 atm operating at 75% of the critical heat flux.

**FIND:** (a) Number of tubes,  $N$ , required to evaporate at a rate of 750 kg/h; tube surface temperature,  $T_s$ , for these conditions, and (b) Compute and plot  $T_s$  and  $N$  required to provide the prescribed vapor production as a function of the heat flux ratio,  $0.25 \leq q_s''/q_{s,\max}'' \leq 0.90$ .

**SCHEMATIC:**

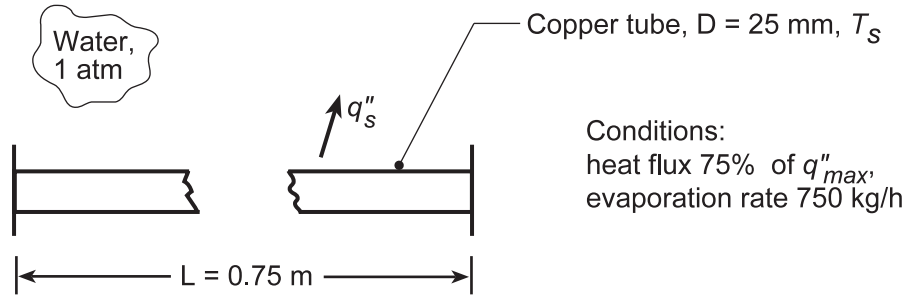

**ASSUMPTIONS:** (1) Nucleate pool boiling, (2) Polished copper tube surfaces.

**PROPERTIES:** Table A-6, Saturated water (100°C):  $\rho_\ell = 957.9 \text{ kg/m}^3$ ,  $c_{p,\ell} = 4217 \text{ J/kg}\cdot\text{K}$ ,  $\mu_\ell = 279 \times 10^{-6} \text{ N}\cdot\text{s/m}^2$ ,  $\text{Pr}_\ell = 1.76$ ,  $h_{fg} = 2257 \text{ kJ/kg}$ ,  $\sigma = 58.9 \times 10^{-3} \text{ N/m}$ ,  $\rho_v = 0.5955 \text{ kg/m}^3$ .

**ANALYSIS:** (a) The total number of tubes,  $N$ , can be evaluated from the rate equations

$$q = q_s'' A_s = q_s'' N \pi D L \quad q = \dot{m} h_{fg} \quad N = \dot{m} h_{fg} / q_s'' \pi D L \quad (1,2,3)$$

The tubes are operated at 75% of the critical flux. From Eq. 10.6, the heat flux is

$$q_{s,\max}'' = 0.75 \times C h_{fg} \rho_v \left[ \frac{\sigma g (\rho_\ell - \rho_v)}{\rho_v^2} \right]^{1/4} = 0.75 \times 0.131 \times 2257 \times 10^3 \text{ J/kg} \times 0.5955 \text{ kg/m}^3 \times$$

$$\left[ \frac{58.9 \times 10^{-3} \text{ N/m} \times 9.8 \text{ m/s}^2 (957.9 - 0.5955) \text{ kg/m}^3}{(0.5955 \text{ kg/m}^3)^2} \right]^{1/4} = 8.30 \times 10^5 \text{ W/m}^2$$

Substituting numerical values into Eq. (3), find

$$N = \frac{750 \text{ kg/h}}{3600 \text{ s/h}} \times 2257 \times 10^3 \text{ J/kg} / \left( 8.30 \times 10^5 \text{ W/m}^2 \times \pi \times 0.025 \text{ m} \times 0.75 \text{ m} \right) = 9.6 \approx 10. \blacktriangleleft$$

To determine the tube surface temperature, use the Rohsenow correlation,

$$\Delta T_e = \frac{C_{s,f} h_{fg} \text{Pr}_\ell^n}{c_{p,\ell}} \left( \frac{q_s''}{\mu_\ell h_{fg}} \right)^{1/3} \left[ \frac{\sigma}{g (\rho_\ell - \rho_v)} \right]^{1/6}$$

From Table 10.1 for the polished copper-water combination,  $C_{s,f} = 0.0128$  and  $n = 1.0$ .

Continued...

**PROBLEM 10.16 (Cont.)**

$$\Delta T_e = \frac{0.0128 \times 2257 \times 10^3 \text{ J/kg} (1.76)^1}{4217 \text{ J/kg} \cdot \text{K}} \left( \frac{8.30 \times 10^5 \text{ W/m}^2}{279 \times 10^{-6} \text{ N} \cdot \text{s/m}^2 \times 2257 \times 10^3 \text{ J/kg}} \right)^{1/3} \times \left[ \frac{58.9 \times 10^{-3} \text{ N/m}}{9.8 \text{ m/s}^2 (957.9 - 0.5955) \text{ kg/m}^3} \right]^{1/6} = 18.0^\circ \text{C}.$$

Hence,

$$T_s = T_{\text{sat}} + \Delta T_e = (100 + 18.0)^\circ \text{C} = 118^\circ \text{C}.$$

<

(b) Using the *IHT Correlations Tool, Boiling, Nucleate Pool Boiling, Heat flux* and the *Properties Tool for Water*, combined with Eqs. (1,2,3) above, the surface temperature  $T_s$  and  $N$  can be computed as a function of  $q_s''/q_{\text{max}}''$ . The results are plotted below.

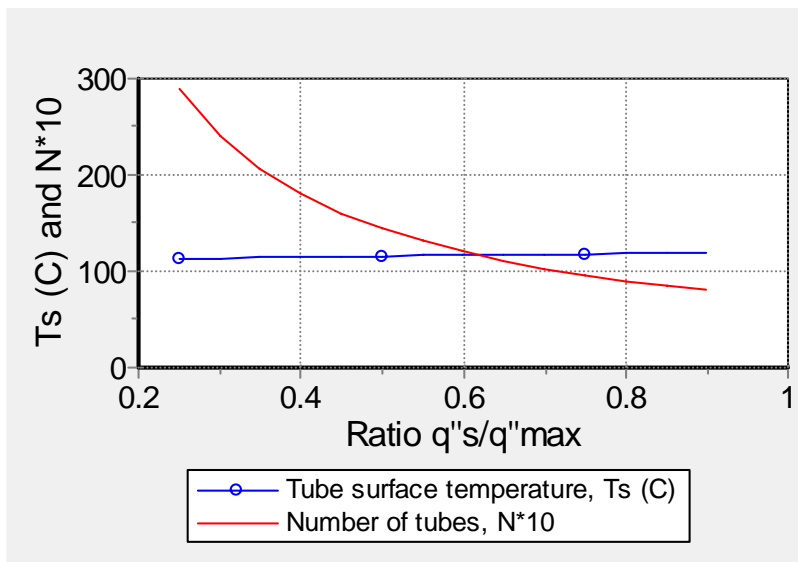

Note that the tube surface temperature increases only slightly (112 to 119°C) as the ratio  $q_s''/q_{\text{max}}''$  increases. The number of tubes required to provide the prescribed evaporation rate decreases markedly as  $q_s''/q_{\text{max}}''$  increases.

**COMMENTS:** The critical heat flux for pool boiling on a flat plate is calculated in Example 10.1 to be  $q_{\text{max}}'' = 1.26 \text{ MW/m}^2$ . For a horizontal cylinder, the critical heat flux is smaller by a factor of  $0.131/0.149 = 0.88$ . Hence, surface curvature effects can impact boiling phenomena.

## PROBLEM 10.17

**KNOWN:** Diameter and length of tube submerged in pressurized water. Water pressure. Flowrate and inlet temperature of gas flow through the tube.

**FIND:** Tube wall and gas outlet temperatures for (a) new, scored tube surfaces and (b) aged conditions with smooth tube walls.

**SCHEMATIC:**

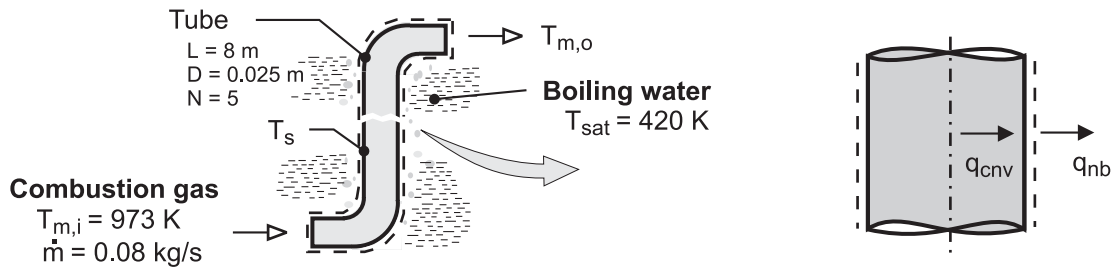

**ASSUMPTIONS:** (1) Steady-state, (2) Uniform tube wall temperature, (3) Nucleate boiling at outer surface of tube, (4) Fully developed flow in tube, (5) Combustion gas is ideal with negligible viscous dissipation and pressure work, (6) Constant properties, (7) Thin tube wall.

**PROPERTIES:** Table A-6, saturated water ( $p_{\text{sat}} = 4.37$  bars):  $T_{\text{sat}} = 420$  K,  $h_{\text{fg}} = 2.123 \times 10^6$  J/kg,  $\rho_{\ell} = 919$  kg/m<sup>3</sup>,  $\rho_{\nu} = 2.4$  kg/m<sup>3</sup>,  $\mu_{\ell} = 185 \times 10^{-6}$  N·s/m<sup>2</sup>,  $c_{p,\ell} = 4302$  J/kg·K,  $\text{Pr}_{\ell} = 1.16$ ,  $\sigma = 0.0494$  N/m. Table A-4, air ( $p = 1$  atm,  $\bar{T}_m \approx 700$  K):  $c_p = 1075$  J/kg·K,  $\mu = 339 \times 10^{-7}$  N·s/m<sup>2</sup>,  $k = 0.0524$  W/m·K,  $\text{Pr} = 0.695$ .

**ANALYSIS:** (a) From an energy balance performed for a control surface that bounds the tube, we know that the rate of heat transfer by convection from the gas to the inner surface must equal the rate of heat transfer due to boiling at the outer surface. Hence, from Eqs. 8.34 and 10.5, the energy balance for a single tube is of the form

$$\dot{m}c_p(T_{m,i} - T_{m,o}) = A_s \mu_{\ell} h_{\text{fg}} \left[ \frac{g(\rho_{\ell} - \rho_{\nu})}{\sigma} \right]^{1/2} \left( \frac{c_{p,\ell} \Delta T_e}{C_{s,f} h_{\text{fg}} \text{Pr}_{\ell}^n} \right)^3 \quad (1)$$

where  $C_{s,f} = 0.0068$  and  $n = 1.0$  from Table 10.1. The corresponding unknowns are the wall temperature  $T_s$  and gas outlet temperature,  $T_{m,o}$ , which are also related through Eq. 8.41b.

$$\frac{T_s - T_{m,o}}{T_s - T_{m,i}} = \exp\left(-\frac{\pi DL \bar{h}}{\dot{m} c_p}\right) \quad (2)$$

For  $\text{Re}_D = 4\dot{m}/\pi D\mu = 119,600$ , the flow is turbulent, and with  $n = 0.3$ , Eq. 8.60 yields,

$$\bar{h} = h_{\text{fd}} = \left(\frac{k}{D}\right) 0.023 \text{Re}_D^{4/5} \text{Pr}^{0.3} = \left(\frac{0.0524 \text{ W/m}\cdot\text{K}}{0.025 \text{ m}}\right) 0.023 (119,600)^{4/5} (0.695)^{0.3} = 502 \text{ W/m}^2 \cdot \text{K}$$

Continued...

### PROBLEM 10.17 (Cont.)

Solving Eqs. (1) and (2), we obtain

$$T_s = 150^\circ\text{C}, \quad T_{m,o} = 164^\circ\text{C} \quad <$$

(b) When the surface degrades to become similar to a polished surface, the value of  $C_{s,f}$  changes to 0.00128. Repeating the calculations yields

$$T_s = 152.6^\circ\text{C}, \quad T_{m,o} = 166.7^\circ\text{C} \quad <$$

**COMMENTS:** (1) The heat rate per tube in part (a) is  $q = \dot{m} c_p (T_{m,i} - T_{m,o}) = 46,100 \text{ W}$ , and the total heat rate is  $Nq = 230,500 \text{ W}$ , in which case the rate of steam production is  $\dot{m}_{\text{steam}} = q / h_{fg} = 0.109 \text{ kg/s}$ . (2) The boiling heat transfer coefficient,  $h_{\text{boil}} = q_s'' / (T_s - T_{\text{sat}})$ , is  $2.5 \times 10^4$  and  $1.3 \times 10^4 \text{ W/m}^2 \cdot \text{K}$  in parts (a) and (b), respectively. This large change has only a small effect on the surface and outlet temperatures because the dominant resistance is the internal forced convection gas resistance. (3) It would not be possible to maintain isothermal tube walls without a large wall thickness, and  $T_s$ , as well as the intensity of boiling, would decrease with increasing distance from the tube entrance. However the foregoing analysis suffices as a first approximation.

## PROBLEM 10.18

**KNOWN:** Nickel wire passing current while submerged in water at atmospheric pressure.

**FIND:** Current at which wire burns out.

**SCHEMATIC:**

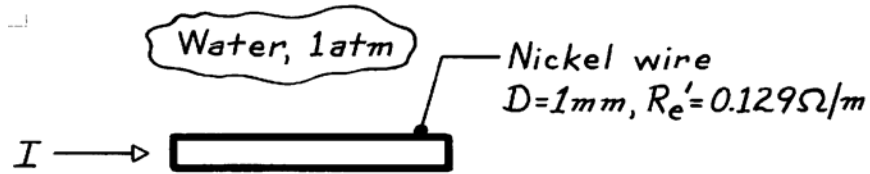

**ASSUMPTIONS:** (1) Steady-state conditions, (2) Pool boiling.

**ANALYSIS:** The burnout condition will occur when electrical power dissipation creates a surface heat flux exceeding the critical heat flux,  $q''_{max}$ . This burn out condition is illustrated on the boiling curve to the right and in Figure 10.3.

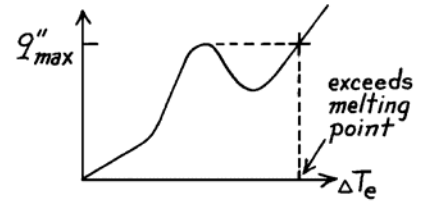

The criterion for burnout can be expressed as

$$q''_{max} \cdot \pi D = q'_{elec} \quad q'_{elec} = I^2 R'_e \quad (1,2)$$

That is,

$$I = [q''_{max} \pi D / R'_e]^{1/2} \quad (3)$$

For pool boiling of water at 1 atm, we found in Example 10.1 that

$$q''_{max} = 1.26 \text{ MW} / \text{m}^2.$$

Substituting numerical values into Eq. (3), find

$$I = \left[ 1.26 \times 10^6 \text{ W} / \text{m}^2 (\pi \times 0.001 \text{ m}) / 0.129 \Omega / \text{m} \right]^{1/2} = 175 \text{ A.} \quad <$$

**COMMENTS:** The magnitude of the current required to burn out the 1 mm diameter wire is very large. What current would burn out the wire in air?

## PROBLEM 10.19

**KNOWN:** Saturated water boiling on a brass plate maintained at  $\Delta T_e = 15^\circ\text{C}$ .

**FIND:** Power required ( $\text{W/m}^2$ ) for pressures of 1 and 10 atm; fraction of critical heat flux at which plate is operating.

**SCHEMATIC:**

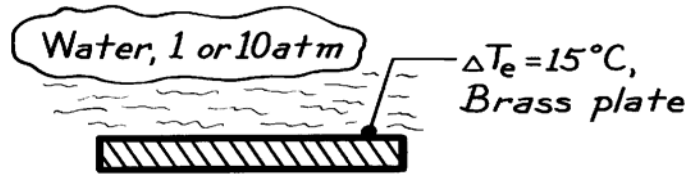

**ASSUMPTIONS:** (1) Nucleate pool boiling, (2)  $\Delta T_e = 15^\circ\text{C}$  for both pressure levels.

**PROPERTIES:** Table A-6, Saturated water, liquid (1 atm,  $T_{\text{sat}} = 100^\circ\text{C}$ ):  $\rho_\ell = 957.9 \text{ kg/m}^3$ ,  $c_{p,\ell} = 4217 \text{ J/kg}\cdot\text{K}$ ,  $\mu_\ell = 279 \times 10^{-6} \text{ N}\cdot\text{s/m}^2$ ,  $\text{Pr}_\ell = 1.76$ ,  $h_{\text{fg}} = 2257 \text{ kJ/kg}$ ,  $\sigma = 58.9 \times 10^{-3} \text{ N/m}$ ; Table A-6, Saturated water, vapor (1 atm):  $\rho_v = 0.596 \text{ kg/m}^3$ ; Table A-6, Saturated water, liquid (10 atm = 10.133 bar,  $T_{\text{sat}} = 453.4 \text{ K} = 180.4^\circ\text{C}$ ):  $\rho_\ell = 886.7 \text{ kg/m}^3$ ,  $c_{p,\ell} = 4410 \text{ J/kg}\cdot\text{K}$ ,  $\mu_\ell = 149 \times 10^{-6} \text{ N}\cdot\text{s/m}^2$ ,  $\text{Pr}_\ell = 0.98$ ,  $h_{\text{fg}} = 2012 \text{ kJ/kg}$ ,  $\sigma = 42.2 \times 10^{-3} \text{ N/m}$ ; Table A-6, Water, vapor (10.133 bar):  $\rho_v = 5.155 \text{ kg/m}^3$ .

**ANALYSIS:** With  $\Delta T_e = 15^\circ\text{C}$ , we expect nucleate pool boiling. The Rohsenow correlation with  $C_{s,f} = 0.006$  and  $n = 1.0$  for the brass-water combination gives

$$q_s'' = \mu_\ell h_{\text{fg}} \left[ \frac{g(\rho_\ell - \rho_v)}{\sigma} \right]^{1/2} \left( \frac{c_{p,\ell} \Delta T_e}{C_{s,f} h_{\text{fg}} \text{Pr}_\ell^n} \right)^3$$

$$1 \text{ atm: } q_s'' = 279 \times 10^{-6} \text{ N}\cdot\text{s/m}^2 \times 2257 \times 10^3 \text{ J/kg} \left[ \frac{9.8 \text{ m/s}^2 (957.9 - 0.596) \text{ kg/m}^3}{58.9 \times 10^{-3} \text{ N/m}} \right]^{1/2} \times \left( \frac{4217 \text{ J/kg}\cdot\text{K} \times 15 \text{ K}}{0.006 \times 2257 \times 10^3 \text{ J/kg} \times 1.76^1} \right)^3 = 4.70 \text{ MW/m}^2$$

$$10 \text{ atm: } q_s'' = 23.8 \text{ MW/m}^2$$

From Example 10.1,  $q_{\text{max}}'' (1 \text{ atm}) = 1.26 \text{ MW/m}^2$ . To find the critical heat flux at 10 atm, use the correlation of Eq. 10.6 with  $C = 0.149$ ,

$$q_{\text{max}}'' = 0.149 h_{\text{fg}} \rho_v \left[ \sigma g(\rho_\ell - \rho_v) / \rho_v^2 \right]^{1/4}$$

$$q_{\text{max}}'' (10 \text{ atm}) = 0.149 \times 2012 \times 10^3 \text{ J/kg} \times 5.155 \text{ kg/m}^3 \times$$

$$\left[ \frac{42.2 \times 10^{-3} \text{ N/m} \times 9.8 \text{ m/s}^2 (886.7 - 5.16) \text{ kg/m}^3}{(5.155 \text{ kg/m}^3)^2} \right]^{1/4} = 2.97 \text{ MW/m}^2$$

For both conditions, the Rohsenow correlation predicts a heat flux that exceeds the maximum heat flux,  $q_{\text{max}}''$ . We conclude that the boiling condition with  $\Delta T_e = 15^\circ\text{C}$  for the brass-water combination is beyond the inflection point (P, see Fig. 10.4) where the boiling heat flux is no longer proportional to  $\Delta T_e^3$ .

$$q_s'' \approx q_{\text{max}}'' (1 \text{ atm}) \leq 1.26 \text{ MW/m}^2 \quad q_s'' \approx q_{\text{max}}'' (10 \text{ atm}) \leq 2.97 \text{ MW/m}^2. \quad <$$



## PROBLEM 10.20

**KNOWN:** Properties of dielectric fluid boiling at 1 atm on a horizontal platinum wire of 0.5 mm diameter. Nucleate boiling constants. Correction factor for small horizontal cylinders.

**FIND:** Temperature of wire when heated at 50% of critical heat flux.

**SCHEMATIC:**

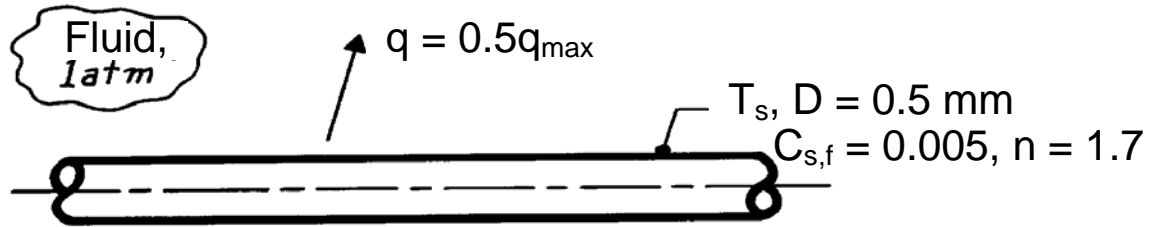

**ASSUMPTIONS:** (1) Steady-state conditions. (2) Nucleate pool boiling.

**PROPERTIES:** Dielectric fluid, given:  $T_{\text{sat}} = 34^\circ\text{C}$ ,  $\rho_\ell = 1400 \text{ kg/m}^3$ ,  $\rho_v = 7.2 \text{ kg/m}^3$ ,  $c_{p,\ell} = 1300 \text{ J/kg}\cdot\text{K}$ ,  $k_\ell = 0.075 \text{ W/m}\cdot\text{K}$ ,  $\nu_\ell = 0.32 \times 10^{-6} \text{ N}\cdot\text{s/m}^2$ ,  $\sigma = 12.4 \times 10^{-3} \text{ N/m}$ ,  $h_{fg} = 142 \text{ kJ/kg}$ .

**ANALYSIS:** The critical heat flux for a large horizontal cylinder can be estimated using Eq. 10.6, with  $C = 0.131$ .

$$\begin{aligned} q''_{\max,\text{large}} &= Ch_{fg}\rho_v \left[ \frac{\sigma g (\rho_\ell - \rho_v)}{\rho_v^2} \right]^{1/4} \\ &= 0.131 \times 142 \times 10^3 \text{ J/kg} \times 7.2 \text{ kg/m}^3 \\ &\quad \times \left[ \frac{12.4 \times 10^{-3} \text{ N/m} \times 9.8 \text{ m/s}^2 \times (1400 - 7.2) \text{ kg/m}^3}{(7.2 \text{ kg/m}^3)^2} \right]^{1/4} \\ &= 180 \text{ kW/m}^2 \end{aligned}$$

The Confinement number is given by  $Co = \sqrt{\sigma/[g(\rho_\ell - \rho_v)]}/R = 3.81$ , which is in the range of applicability of the expression for the correction factor,  $F$ ,

$$F = 0.89 + 2.27 \exp(-3.44Co^{-1/2}) = 0.89 + 2.27 \exp[-3.44(3.81)^{-1/2}] = 1.28$$

The wire is operated at 50% of the critical heat flux or,

$$q''_s = 0.5Fq''_{\max,\text{large}} = 0.5 \times 1.28 \times 180 \text{ kW/m}^2 = 115 \text{ kW/m}^2$$

The excess temperature can then be found from Eq. 10.5, the Rohsenow correlation,

$$q''_s = \mu_\ell h_{fg} \left[ \frac{g(\rho_\ell - \rho_v)}{\sigma} \right]^{1/2} \left( \frac{c_{p,\ell} \Delta T_e}{C_{s,f} h_{fg} Pr_\ell^n} \right)^3 = 115 \text{ kW/m}^2$$

Continued...

### PROBLEM 10.20 (Cont.)

Substituting numerical values, with  $\mu_\ell = \nu_\ell \rho_\ell = 4.48 \times 10^{-4} \text{ m/s}^2$  and  $\text{Pr}_\ell = \mu_\ell c_{p,\ell} / k_\ell = 7.77$ ,

$$4.48 \times 10^{-4} \text{ N} \cdot \text{s/m}^2 \times 142 \times 10^3 \text{ J/kg} \left[ \frac{9.8 \text{ m/s}^2 (1400 - 7.2) \text{ kg/m}^3}{12.4 \times 10^{-3} \text{ N/m}} \right]^{1/2} \times \\ \left( \frac{1300 \text{ J/kg} \cdot \text{K} \times \Delta T_e}{0.005 \times 142 \times 10^3 \text{ J/kg} \times 7.77^{1.7}} \right)^3 = 115 \times 10^3 \text{ W/m}^2$$

$$\Delta T_e = 21.4^\circ\text{C}$$

Thus

$$T_s = 34^\circ\text{C} + 21.4^\circ\text{C} = 55.4^\circ\text{C}$$

<

**COMMENTS:** The critical heat flux on the small wire is 28% higher than on a large cylinder.

## PROBLEM 10.21

**KNOWN:** Zuber-Kutateladze correlation for critical heat flux,  $q''_{\max}$ .

**FIND:** Pressure dependence of  $q''_{\max}$  for water; demonstrate maximum value occurs at approximately  $1/3 p_{\text{crit}}$ ; suggest coordinates for a universal curve to represent other fluids.

**ASSUMPTIONS:** Nucleate pool boiling conditions.

**PROPERTIES:** Table A-6, Water, saturated at various pressures; see below.

**ANALYSIS:** The Z-K correlation for estimating the critical heat flux, has the form

$$q''_{\max} = 0.149 \rho_v h_{fg} \left[ \frac{g \sigma (\rho_\ell - \rho_v)}{\rho_v^2} \right]^{1/4}$$

where the properties for saturation conditions are a function of pressure. The properties (Table A-6) and the values for  $q''_{\max}$  are as follows:

p (bar)	p/p <sub>c</sub>	$\rho_\ell$ (kg/m <sup>3</sup> )	$\rho_v$	$h_{fg}$ (kJ/kg)	$\sigma \times 10^3$ (N/m)	$q''_{\max}$ (MW/m <sup>2</sup> )
1.01	0.0045	957.9	0.59552257	58.9	1.258	
11.71	0.053	879.5	5.988	1989	40.7	3.138
26.40	0.120	831.3	13.05	1825	31.6	3.935
44.58	0.202	788.1	22.47	1679	24.5	4.398
61.19	0.277	755.9	31.55	1564	19.7	4.549
82.16	0.372	718.4	43.86	1429	15.0	4.520
123.5	0.557	648.9	72.99	1176	8.4	4.047
169.1	0.765	562.4	117.6	858	3.5	2.905
221.2	1.000	315.5	315.5	0	0	0

The  $q''_{\max}$  values are plotted as a function of  $p/p_c$ , where  $p_c$  is the critical pressure. Note the rapid decrease of  $h_{fg}$  and  $\sigma$  with increasing pressure. The universal curve coordinates would be  $q''_{\max} / q''_{\max}(1/3 p_{\text{crit}})$  vs.  $p/p_c$ .

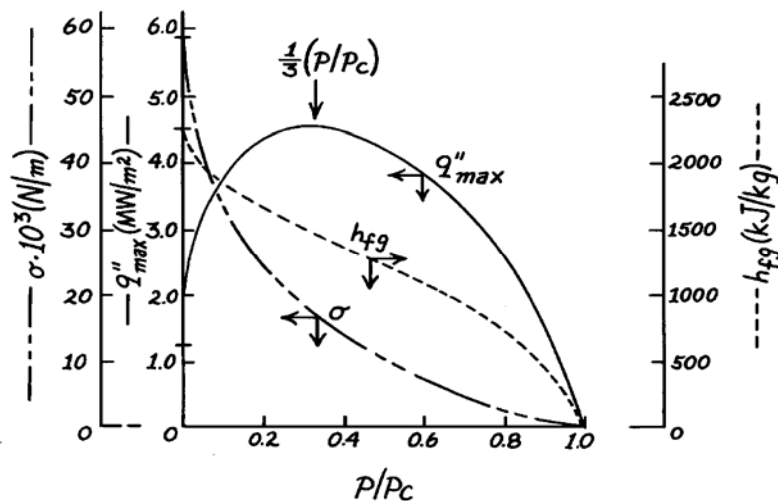

<

## PROBLEM 10.22

**KNOWN:** Kutateladze's dimensional analysis and the bubble diameter parameter.

**FIND:** Verify the dimensional consistency of the critical heat flux expression.

**ASSUMPTIONS:** Nucleate pool boiling.

**ANALYSIS:** Kutateladze postulated that the critical flux was dependent upon four parameters,

$$q''_{\max} = q''_{\max}(h_{fg}, \rho_v, \sigma, D_b)$$

where  $D_b$  is the bubble diameter parameter having the form

$$D_b = [\sigma / g(\rho_\ell - \rho_v)]^{1/2}. \quad (1)$$

The form of the critical heat flux expression was presumed to be

$$q''_{\max} = C h_{fg} \rho_v^{1/2} D_b^{-1/2} \sigma^{1/2} \quad (2)$$

where  $C$  is a constant. It is not possible to derive this equation from a dimensional (Pi) analysis. We can only determine that the equation is dimensionally consistent. Using SI units, check Eq. (1) for  $D_b$ ,

$$D_b \Rightarrow \left[ (\text{Nm}^{-1}) (\text{m}^{-1}\text{s}^2) (\text{kg}^{-1}\text{m}^3) \right]^{1/2} \Rightarrow \left[ \text{N} \left( \frac{\text{s}^2}{\text{kg} \cdot \text{m}} \right) \text{m}^2 \right]^{1/2} \Rightarrow [\text{m}]$$

and in Eq. (2) for  $q''_{\max}$ ,

$$q''_{\max} \Rightarrow \left[ (\text{J kg}^{-1}) (\text{kg}^{1/2} \text{m}^{-3/2}) (\text{m}^{-1/2}) (\text{N}^{1/2} \text{m}^{-1/2}) \right] \Rightarrow \left[ \frac{\text{J}}{\text{s}} \cdot \left( \frac{\text{N} \cdot \text{s}^2}{\text{kg} \cdot \text{m}} \right)^{1/2} \text{m}^{-2} \right] \Rightarrow \left[ \frac{\text{W}}{\text{m}^2} \right].$$

Hence, the equations are dimensionally consistent.

**COMMENTS:** Dimensional (Pi) analysis yields the following result:  $q''_{\max} / \rho_v h_{fg}^{2/3} = f(\sigma / \rho_v h_{fg} D_b)$ .

If  $f(\sigma / \rho_v h_{fg} D_b) = C(\sigma / \rho_v h_{fg} D_b)^{1/2}$ , we recover Eq.(2).

### PROBLEM 10.23

**KNOWN:** Thickness and thermal conductivity of a silicon chip. Properties of saturated fluorocarbon liquid.

**FIND:** (a) Temperature at bottom surface of chip for a prescribed heat flux and 90% of CHF, (b) Effect of heat flux on chip surface temperatures; maximum allowable heat flux.

**SCHEMATIC:**

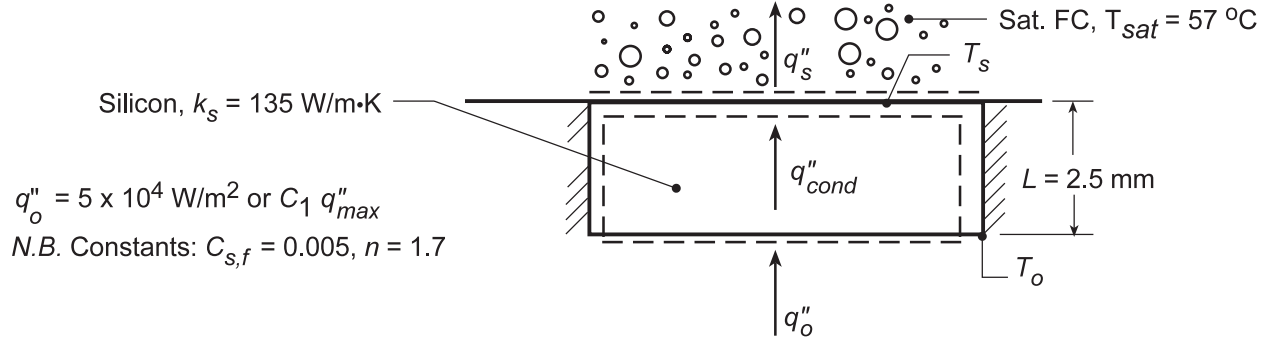

**ASSUMPTIONS:** (1) Steady-state conditions, (2) Uniform heat flux and adiabatic sides, hence one-dimensional conduction in chip, (3) Constant properties, (4) Nucleate boiling in liquid.

**PROPERTIES:** Saturated fluorocarbon (given):  $c_{p,l} = 1100 \text{ J/kg}\cdot\text{K}$ ,  $h_{fg} = 84,400 \text{ J/kg}$ ,  $\rho_l = 1619.2 \text{ kg/m}^3$ ,  $\rho_v = 13.4 \text{ kg/m}^3$ ,  $\sigma = 8.1 \times 10^{-3} \text{ kg/s}^2$ ,  $\mu_l = 440 \times 10^{-6} \text{ kg/m}\cdot\text{s}$ ,  $\text{Pr}_l = 9.01$ .

**ANALYSIS:** (a) Energy balances at the top and bottom surfaces yield  $q_o'' = q''_{cond} = k_s (T_o - T_s)/L = q_s''$ ; where  $T_s$  and  $q_s''$  are related by the Rohsenow correlation,

$$T_s - T_{sat} = \frac{C_{s,f} h_{fg} \text{Pr}_l^n}{c_{p,l}} \left( \frac{q_s''}{\mu_l h_{fg}} \right)^{1/3} \left[ \frac{\sigma}{g(\rho_l - \rho_v)} \right]^{1/6}$$

Hence, for  $q_s'' = 5 \times 10^4 \text{ W/m}^2$ ,

$$T_s - T_{sat} = \frac{0.005(84,400 \text{ J/kg})9.01^{1.7}}{1100 \text{ J/kg}\cdot\text{K}} \left( \frac{5 \times 10^4 \text{ W/m}^2}{440 \times 10^{-6} \text{ kg/m}\cdot\text{s} \times 84,400 \text{ J/kg}} \right)^{1/3} \times \left[ \frac{8.1 \times 10^{-3} \text{ kg/s}^2}{9.8 \text{ m/s}^2 (1619.2 - 13.4) \text{ kg/m}^3} \right]^{1/6} = 15.9^\circ \text{C}$$

$$T_s = (15.9 + 57)^\circ \text{C} = 72.9^\circ \text{C}.$$

From Fourier's law,

$$T_o = T_s + \frac{q_o'' L}{k_s} = 72.9^\circ \text{C} + \frac{5 \times 10^4 \text{ W/m}^2 \times 0.0025 \text{ m}}{135 \text{ W/m}\cdot\text{K}} = 73.8^\circ \text{C} \quad <$$

For a heat flux which is 90% of the critical heat flux ( $C_1 = 0.9$ ), it follows that

$$q_o'' = 0.9 q_{max}'' = 0.9 \times 0.149 h_{fg} \rho_v \left[ \frac{\sigma g (\rho_l - \rho_v)}{\rho_v^2} \right]^{1/4} = 0.9 \times 0.149 \times 84,400 \text{ J/kg} \times 13.4 \text{ kg/m}^3$$

Continued...

**PROBLEM 10.23 (Cont.)**

$$\times \left[ \frac{8.1 \times 10^{-3} \text{ kg/s}^2 \times 9.8 \text{ m/s}^2 (1619.2 - 13.4) \text{ kg/m}^3}{(13.4 \text{ kg/m}^3)^2} \right]^{1/4}$$

$$q''_o = 0.9 \times 15.5 \times 10^4 \text{ W/m}^2 = 13.9 \times 10^4 \text{ W/m}^2$$

From the results of the previous calculation and the Rohsenow correlation, it follows that

$$\Delta T_e = 15.9^\circ \text{C} \left( q''_o / 5 \times 10^4 \text{ W/m}^2 \right)^{1/3} = 15.9^\circ \text{C} (13.9/5)^{1/3} = 22.4^\circ \text{C}$$

Hence,  $T_s = 79.4^\circ \text{C}$  and

$$T_o = 79.4^\circ \text{C} + \frac{13.9 \times 10^4 \text{ W/m}^2 \times 0.0025 \text{ m}}{135 \text{ W/m} \cdot \text{K}} = 82^\circ \text{C}$$

<

(b) Using the energy balance equations with the *Correlations* Toolpad of IHT to perform the parametric calculations for  $0.2 \leq C_1 \leq 0.9$ , the following results are obtained.

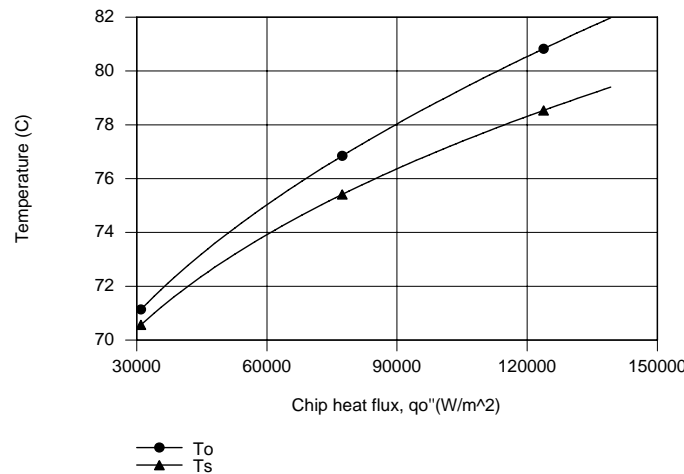

The chip surface temperatures, as well as the difference between temperatures, increase with increasing heat flux. The maximum chip temperature is associated with the bottom surface, and  $T_o = 80^\circ \text{C}$  corresponds to

$$q''_{o,\max} = 11.3 \times 10^4 \text{ W/m}^2$$

<

which is 73% of CHF ( $q''_{\max} = 15.5 \times 10^4 \text{ W/m}^2$ ).

**COMMENTS:** Many of today's VLSI chip designs involve heat fluxes well in excess of  $15 \text{ W/cm}^2$ , in which case pool boiling in a fluorocarbon would not be an appropriate means of heat dissipation.

### PROBLEM 10.24

**KNOWN:** Boiling water at 1 atm pressure on moon where the gravitational field is 1/6 that of the earth.

**FIND:** Critical heat flux.

**ASSUMPTIONS:** Nucleate pool boiling conditions.

**PROPERTIES:** Table A-6, Water (1 atm):  $T_{\text{sat}} = 100^\circ\text{C}$ ,  $\rho_\ell = 957.9 \text{ kg/m}^3$ ,  $\rho_v = 0.5955 \text{ kg/m}^3$ ,  $h_{\text{fg}} = 2257 \text{ kJ/kg}$ ,  $\sigma = 58.9 \times 10^{-3} \text{ N/m}$ .

**ANALYSIS:** The critical heat flux is given by Eq. 10.6 with  $C=0.149$ .

$$q''_{\text{max}} = 0.149 \rho_v^{1/2} h_{\text{fg}} [\sigma g (\rho_\ell - \rho_v)]^{1/4}.$$

The relation predicts the critical flux dependency on the gravitational acceleration as

$$q''_{\text{max}} \sim g^{1/4}.$$

It follows that if  $g_{\text{moon}} = (1/6) g_{\text{earth}}$  and recognizing  $q''_{\text{max,e}} = 1.26 \text{ MW/m}^2$  for earth acceleration (see Example 10.1),

$$q''_{\text{max,moon}} = q''_{\text{max,earth}} (g_{\text{moon}} / g_{\text{earth}})^{1/4}$$

$$q''_{\text{max,moon}} = 1.26 \frac{\text{MW}}{\text{m}^2} \left(\frac{1}{6}\right)^{1/4} = 0.81 \text{ MW/m}^2. \quad <$$

**COMMENTS:** Note from the discussion in Section 10.4.5 that the  $g^{1/4}$  dependence on the critical heat flux has been experimentally confirmed. In the nucleate pool boiling regime, the heat flux is nearly independent of the gravitational field.

## PROBLEM 10.25

**KNOWN:** Concentric stainless steel tubes packed with dense boron nitride powder. Inner tube has heat generation while outer tube surface is exposed to boiling heat flux,  $q_s'' = C(T_s - T_{sat})^3$ . Saturation temperature of boiling liquid and temperature of the outer tube surface.

**FIND:** Expressions for the maximum temperature in the stainless steel (ss) tubes and in the boron nitride (bn).

**SCHEMATIC:**

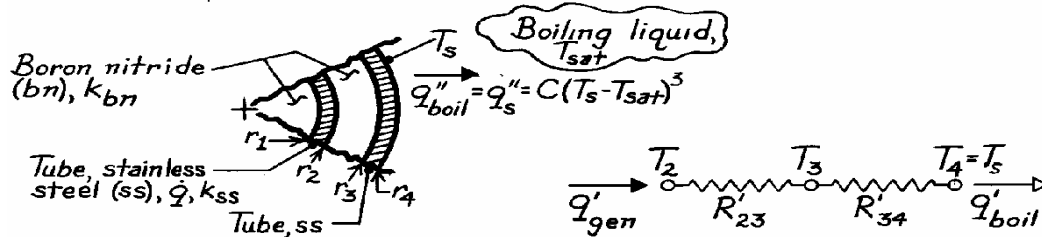

**ASSUMPTIONS:** (1) Steady-state conditions, (2) One-dimensional (cylindrical) steady-state heat transfer in tubes and boron nitride.

**ANALYSIS:** Construct the thermal circuit shown above where  $R'_{23}$  and  $R'_{34}$  represent the resistances due to the boron nitride between  $r_2$  and  $r_3$  and to the outer stainless steel tube, respectively. From an overall energy balance,

$$q'_{gen} = q'_{boil}$$

$$\dot{q}\pi(r_2^2 - r_1^2) = (2\pi r_4)C(T_s - T_{sat})^3.$$

With prescribed values for  $T_{sat}$ ,  $T_s$  and  $C$ , the required volumetric heating of the inner stainless steel tube is

$$\dot{q} = \frac{2r_4}{(r_2^2 - r_1^2)} C(T_s - T_{sat})^3.$$

Using the thermal circuit, we can write expressions for the *maximum* temperature of the stainless steel (ss) and boron nitride (bn).

*Stainless steel:*  $T_{ss,max}$  occurs at  $r_1$ . Using the results of Section 3.5.2, the temperature distribution in a radial tube of inner and outer radii  $r_1$  and  $r_2$  is

$$T(r) = -\frac{\dot{q}}{4k_{ss}}r^2 + C_1 \ln r + C_2$$

for which the boundary conditions are

$$\text{BC\#1:} \quad r = r_1 \quad \frac{dT}{dr} = 0 \quad 0 = -\frac{\dot{q}}{4k_{ss}}2r_1 + \frac{C_1}{r_1} + 0 \rightarrow C_1 = +\frac{\dot{q}r_1^2}{2k_{ss}}$$

Continued ...



**PROBLEM 10.25 (Cont.)**

$$\text{BC \#2:} \quad r = r_2 \quad T(r_2) = T_2 \quad T_2 = -\frac{\dot{q}}{4k_{ss}}r_2^2 + \frac{\dot{q}r_1^2}{2k_{ss}}\ln r_2 + C_2$$

$$C_2 = T_2 + \frac{\dot{q}}{4k_{ss}}r_2^2 - \frac{\dot{q}r_1^2}{2k_{ss}}\ln r_2$$

Hence,

$$T(r) = -\frac{\dot{q}}{4k_{ss}}(r^2 - r_2^2) + \frac{\dot{q}r_1^2}{2k_{ss}}\ln(r/r_2) + T_2.$$

Using the thermal circuit, find  $T_2$  in terms of known parameters  $T_s$ ,  $T_{\text{sat}}$  and  $C$ .

$$\frac{T_2 - T_s}{R'_{23} + R'_{34}} = (2\pi r_4)C(T_s - T_{\text{sat}})^3.$$

Hence, the maximum temperature in the inner stainless steel tube ( $r = r_1$ ) is

$$T_{\text{ss,max}} = T(r_1) = -\frac{\dot{q}}{4k_{ss}}(r_1^2 - r_2^2) + \frac{\dot{q}r_1^2}{2k_{ss}}\ln(r_1/r_2) + T_s$$

$$+ (R'_{23} + R'_{34})(2\pi r_4)C(T_s - T_{\text{sat}})^3 \quad <$$

where from Eq. 3.33

$$R'_{23} = \frac{\ln(r_3/r_2)}{2\pi k_{\text{bn}}} \quad R'_{34} = \frac{\ln(r_4/r_3)}{2\pi k_{\text{ss}}}.$$

*Boron nitride:*  $T_{\text{bn,max}}$  occurs at  $r_1$ . Hence

$$T_{\text{bn,max}} = T(r_1) \quad <$$

as derived above for the inner stainless steel tube.

## PROBLEM 10.26

**KNOWN:** Operating conditions of apparatus used to determine surface boiling characteristics.

**FIND:** (a) Nucleate boiling coefficient for special coating, (b) Surface temperature as a function of heat flux; apparatus temperatures for a prescribed heat flux; applicability of nucleate boiling correlation for a specified heat flux.

**SCHEMATIC:**

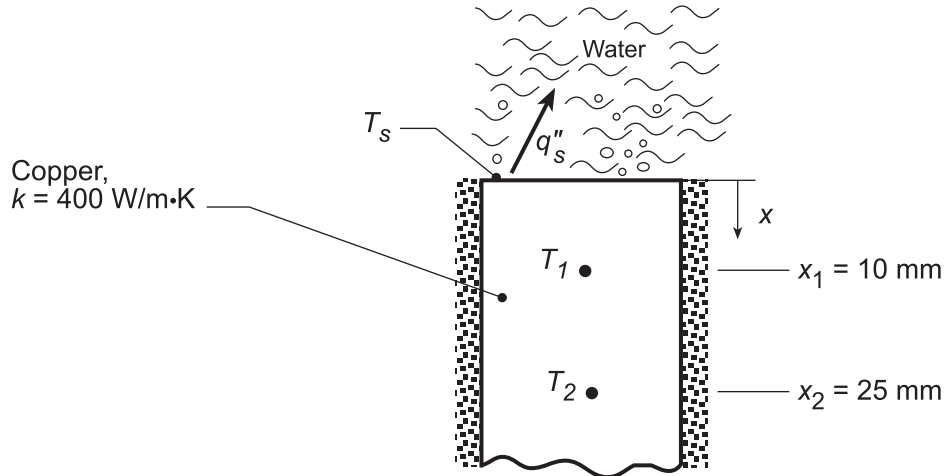

**ASSUMPTIONS:** (1) One-dimensional, steady-state conduction in the bar, (2) Water is saturated at 1 atm, (3) Applicability of Rohsenow correlation with  $n = 1$ .

**PROPERTIES:** Table A.6, saturated water (100°C):  $\rho_\ell = 957.9 \text{ kg/m}^3$ ,  $c_{p,\ell} = 4217 \text{ J/kg}\cdot\text{K}$ ,  $\mu_\ell = 279 \times 10^{-6} \text{ N}\cdot\text{s/m}^2$ ,  $\text{Pr}_\ell = 1.76$ ,  $h_{fg} = 2.257 \times 10^6 \text{ J/kg}$ ,  $\sigma = 0.0589 \text{ N/m}$ ,  $\rho_v = 0.5955 \text{ kg/m}^3$ .

**ANALYSIS:** (a) The coefficient  $C_{s,f}$  associated with Eq. 10.5 may be determined if  $q_s''$  and  $T_s$  are known. Applying Fourier's law between  $x_1$  and  $x_2$ ,

$$q_s'' = q_{\text{cond}}'' = k \frac{T_2 - T_1}{x_2 - x_1} = 400 \text{ W/m}\cdot\text{K} \times \frac{(158.6 - 133.7)^\circ\text{C}}{0.015 \text{ m}} = 6.64 \times 10^5 \text{ W/m}^2$$

Since the temperature distribution in the bar is linear,  $T_s = T_1 - (dT/dx)x_1 = T_1 - [(T_2 - T_1)/(x_2 - x_1)]x_1$ . Hence,

$$T_s = 133.7^\circ\text{C} - \left[ 24.9^\circ\text{C}/0.015 \text{ m} \right] 0.01 \text{ m} = 117.1^\circ\text{C}$$

From Eq. 10.5, with  $n = 1$ ,

$$C_{s,f} = \frac{c_{p,\ell} \Delta T_e}{h_{fg} \text{Pr}_\ell} \left( \frac{\mu_\ell h_{fg}}{q_s''} \right)^{1/3} \left[ \frac{g(\rho_\ell - \rho_v)}{\sigma} \right]^{1/6}$$

$$C_{s,f} = \frac{4217 \text{ J/kg}\cdot\text{K} (17.1^\circ\text{C})}{2.257 \times 10^6 \text{ J/kg} (1.76)} \left( \frac{279 \times 10^{-6} \text{ kg/s}\cdot\text{m} \times 2.257 \times 10^6 \text{ J/kg}}{6.64 \times 10^5 \text{ W/m}^2} \right)^{1/3} \left[ \frac{9.8 \text{ m/s}^2 \times 957.3 \text{ kg/m}^3}{0.0589 \text{ kg/s}^2} \right]^{1/6}$$

$$C_{s,f} = 0.0131 \quad \leftarrow$$

(b) Using the appropriate IHT *Correlations and Properties* Toolpads, the following portion of the nucleate boiling regime was computed.

Continued...

### PROBLEM 10.26 (Cont.)

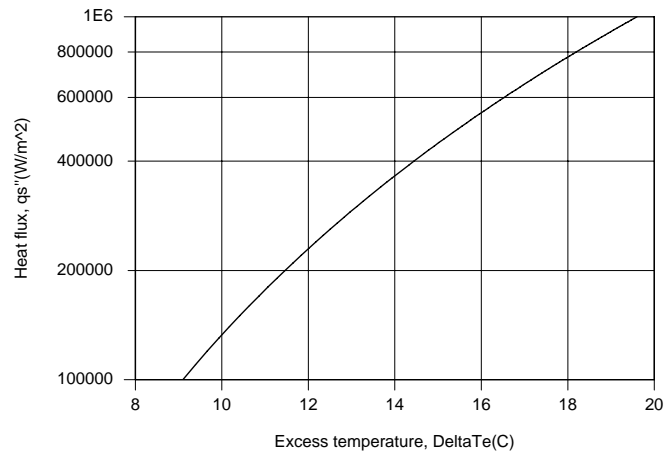

For  $q_s'' = 10^6 \text{ W/m}^2 = q_{\text{cond}}''$ ,  $T_s = 119.6^\circ\text{C}$  and

$$T_1 = 144.6^\circ\text{C} \quad \text{and} \quad T_2 = 182.1^\circ\text{C}$$

With the critical heat flux given by Eq. 10.6 with  $C=0.149$ ,

$$q_{\text{max}}'' = 0.149 h_{\text{fg}} \rho_v \left[ \frac{\sigma g (\rho_\ell - \rho_v)}{\rho_v^2} \right]^{1/4}$$

$$q_{\text{max}}'' = 0.149 \left( 2.257 \times 10^6 \text{ J/kg} \right) 0.5955 \text{ kg/m}^3 \left[ \frac{0.0589 \text{ kg/s}^2 \times 9.8 \text{ m/s}^2 \times 957.3 \text{ kg/m}^3}{(0.5955 \text{ kg/m}^3)^2} \right]^{1/4}$$

$$q_{\text{max}}'' = 1.25 \times 10^6 \text{ W/m}^2$$

Since  $q_s'' = 1.5 \times 10^6 \text{ W/m}^2 > q_{\text{max}}''$ , the heat flux exceeds that associated with nucleate boiling and the foregoing results can not be used.

**COMMENTS:** For  $q_s'' > q_{\text{max}}''$ , conditions correspond to film boiling, for which  $T_s$  may exceed acceptable operating conditions.

## PROBLEM 10.27

**KNOWN:** Small copper sphere, initially at a uniform temperature,  $T_i$ , greater than that corresponding to the Leidenfrost point,  $T_D$ , suddenly immersed in a large fluid bath maintained at  $T_{sat}$ .

**FIND:** (a) Sketch the temperature-time history,  $T(t)$ , during the quenching process; indicate temperature corresponding to  $T_i$ ,  $T_D$ , and  $T_{sat}$ , identify regimes of film, transition and nucleate boiling and the single-phase convection regime; identify key features; and (b) Identify times(s) in this quenching process when you expect the surface temperature of the sphere to deviate most from its center temperature.

**SCHEMATIC:**

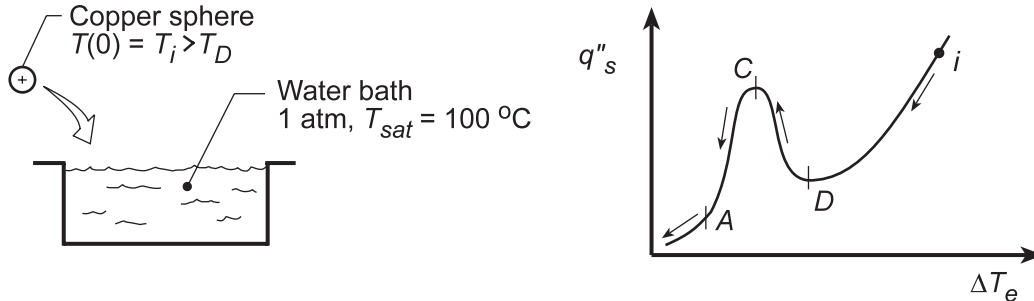

**ANALYSIS:** (a) In the right-hand schematic above, the quench process is shown on the “boiling curve” similar to Figure 10.4. Beginning at an initial temperature,  $T_i > T_D$ , the process proceeds as indicated by the arrows: film regime from  $i$  to  $D$ , transition regime from  $D$  to  $C$ , nucleate regime from  $C$  to  $A$ , and single-phase (free convection) from  $A$  to the condition when  $\Delta T_e = T_s - T_{sat} = 0$ . The quench process is shown on the temperature-time plot below and the boiling regimes and key temperatures are labeled..

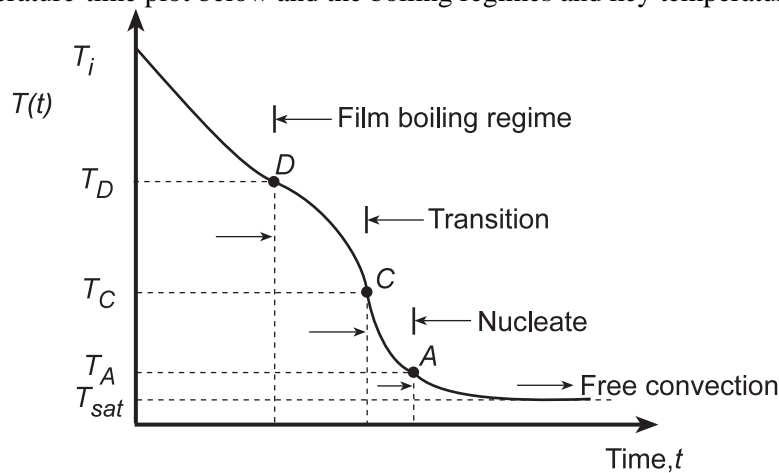

The highest temperature-time change should occur in the nucleate pool boiling regime, especially near the critical flux condition,  $T_c$ . The lowest temperature-time change will occur in the single-phase, free convection regime.

(b) The difference between the center and surface temperatures will be greatest when the Biot number is largest, which occurs in regimes with the highest convection coefficients. The convection coefficient is maximum at point  $P$  on the boiling curve of Fig. 10.4, which falls between points  $C$  and  $A$  on the above plots.

## PROBLEM 10.28

**KNOWN:** A sphere (aluminum alloy 2024) with a uniform temperature of 500°C and emissivity of 0.25 is suddenly immersed in a saturated water bath maintained at atmospheric pressure.

**FIND:** (a) The total heat transfer coefficient for the initial condition; fraction of the total coefficient contributed by radiation; and (b) Estimate the temperature of the sphere 30 s after it has been immersed in the bath.

**SCHEMATIC:**

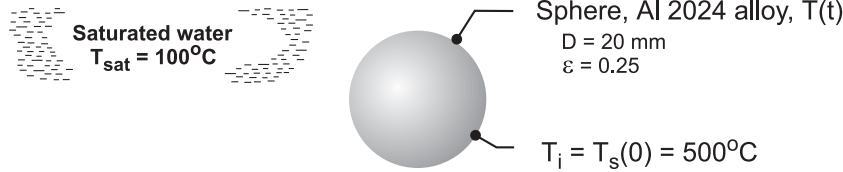

**ASSUMPTIONS:** (1) Water exposed to standard atmospheric pressure and uniform temperature,  $T_{\text{sat}}$ , and (2) Lumped capacitance method is valid.

**PROPERTIES:** See Comment 2; properties obtained with *IHT* code.

**ANALYSIS:** (a) For the initial condition with  $T_s = 500^\circ\text{C}$ , *film boiling* will occur and the coefficients due to convection and radiation are estimated using Eqs. 10.8 and 10.11, respectively,

$$\overline{\text{Nu}}_D = \frac{\bar{h}_{\text{conv}} D}{k_v} = C \left[ \frac{g(\rho_\ell - \rho_v) h'_{\text{fg}} D^3}{\nu_v k_v (T_s - T_{\text{sat}})} \right]^{1/4} \quad (1)$$

$$\bar{h}_{\text{rad}} = \frac{\varepsilon \sigma (T_s^4 - T_{\text{sat}}^4)}{T_s - T_{\text{sat}}} \quad (2)$$

where  $C = 0.67$  for spheres and  $\sigma = 5.67 \times 10^{-8} \text{ W/m}^2 \cdot \text{K}^4$ . The corrected latent heat is

$$h'_{\text{fg}} = h_{\text{fg}} + 0.8 c_{p,v} (T_s - T_{\text{sat}}) \quad (3)$$

The total heat transfer coefficient is given by Eq. 10.9 as

$$\bar{h}^{4/3} = \bar{h}_{\text{conv}}^{4/3} + \bar{h}_{\text{rad}} \cdot \bar{h}^{1/3} \quad (4)$$

The vapor properties are evaluated at the film temperature,

$$T_f = (T_s + T_{\text{sat}}) / 2 \quad (5)$$

while the liquid properties are evaluated at the saturation temperature. Using the foregoing relations in *IHT* (see Comments), the following results are obtained.

$\overline{\text{Nu}}_D$	$\bar{h}_{\text{cnv}} \left( \text{W/m}^2 \cdot \text{K} \right)$	$\bar{h}_{\text{rad}} \left( \text{W/m}^2 \cdot \text{K} \right)$	$\bar{h} \left( \text{W/m}^2 \cdot \text{K} \right)$	
85.5	171	12.0	180	<

The radiation process contribution is 6.7% that of the total heat rate.

(b) For the lumped-capacitance method, from Section 5.3, the energy balance is

$$-\bar{h} A_s (T_s - T_{\text{sat}}) = \rho_s V c_s \frac{dT_s}{dt} \quad (6)$$

where  $\rho_s$  and  $c_s$  are properties of the sphere. To determine  $T_s(t)$ , it is necessary to evaluate  $\bar{h}$  as a function of  $T_s$ . Using the foregoing relations in *IHT* (see Comments), the sphere temperature after 30s is

$$T_s(30\text{s}) = 300^\circ\text{C}. \quad <$$

Continued ...

## PROBLEM 10.28 (Cont.)

**COMMENTS:** (1) The Biot number associated with the aluminum alloy sphere cooling process for the initial condition is  $Bi = 0.019$ . Hence, the lumped-capacitance method is valid.

(2) The *IHT* code to solve this application uses the film-boiling correlation, the water properties functions, and the lumped capacitance energy balance, Eq. (6). The results for part (a), including the properties required of the correlation, are shown at the outset of the code.

```

/* Results, Part (a): Initial conditions, Ts = 500 C
NuDbar hbar hcvar hradbar F
85.5 180 171 12.0 0.0667 /*

/* Properties: Initial Conditions, Ts = 500 C, Tf = 573 K
rhov cpv nuv kv rho hfg h'fg
0.3843 2010 51.44E-6 0.03988 958 2257E3 2.901E6 */

/* Results: with initial condition, Ts = 500 C; after 30 s
Bi F Ts_C hbar t
0.019 0.067 500 180 0
0.020 0.033 300 188 30 */

//LCM analysis, energy balance
-hbar*As*(Ts-Tsat) = rhos * Vol * cps * der(Ts,t)
As = pi*D^2
Vol = pi*D^3/6

/* Correlation description: coefficients for film pool boiling (FPB). Eqs. 10.8, 10.9, and
10.11. See boiling curve, Fig. 10.4. */
NuDbar = NuD_bar_FPB(C,rho,rhov,h'fg,nuv,kv,deltaTe,D,g) // Eq 10.8
NuDbar = hcvar * D / kv
g = 9.8 // gravitational constant, m/s^2
deltaTe = Ts - Tsat // excess temperature, K
//Ts_C = 500 // surface temperature, K
Ts_C = Ts - 273
Tsat = 373 // saturation temperature, K
// The vapor properties are evaluated at the film temperature,Tf,
Tf = Tfluid_avg(Ts,Tsat)
// The correlation constant is 0.62 or 0.67 for cylinders or spheres,
C = 0.67
// The corrected latent heat is
h'fg = hfg + 0.80*cpv*(Ts - Tsat)
// The radiation coefficient is
hradbar = eps * sigma * (Ts^4 - Tsat^4) / (Ts - Tsat) // Eq 10.11
sigma = 5.67E-8 // Stefan-Boltzmann constant, W/m^2-K^4
eps = 0.25 // surface emissivity
// The total heat transfer coefficient is
hbar^(4/3) = hcvar^(4/3) + hradbar * hbar^(1/3) // Eq 10.9
F = hradbar / hbar // fractional contribution of radiation

// Input variables
D = 0.020
rhos = 2702 // Sphere properties, aluminum alloy 2024
cps = 875
ks = 186
Bi = hbar * D / ks

// Water properties
// Water property functions :T dependence, From Table A.6
//Saturated liquid properties. Units: T(K);
rho = rho_T("Water",Tsat,0) // Density, kg/m^3
hfg = hfg_T("Water",Tsat) // Heat of vaporization, J/kg

// Water vapor property functions : From Table A.4
// Units: T(K); 1 atm pressure
rhov = rho_T("Water Vapor",Tf) // Density, kg/m^3
cpv = cp_T("Water Vapor",Tf) // Specific heat, J/kg-K
nuv = nu_T("Water Vapor",Tf) // Kinematic viscosity, m^2/s
kv = k_T("Water Vapor",Tf) // Thermal conductivity, W/m-K

```

## PROBLEM 10.29

**KNOWN:** Initial temperature of hot rotor, temperature of water quenching bath, rotor orientation.

**FIND:** (a) Sketch of the rotor temperature versus time for Orientation A, (b) Relative cooling rate of the rotor for Orientation B.

**SCHEMATIC:**

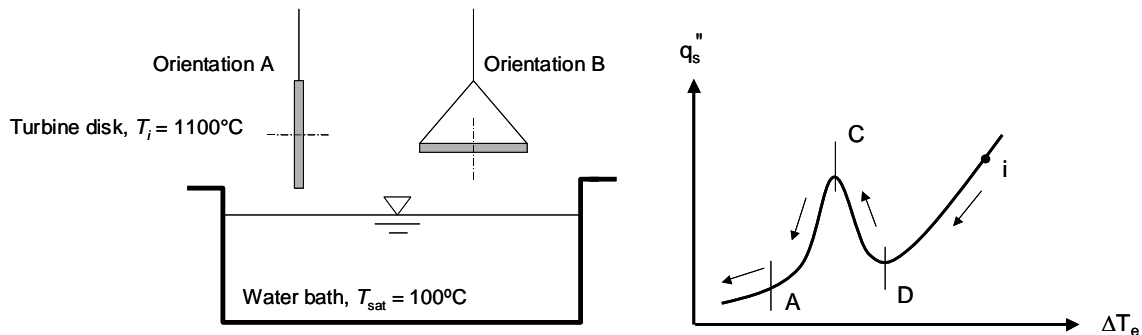

**ASSUMPTIONS:** (1) Lumped capacitance behavior, (2) Constant properties.

**ANALYSIS:** Assuming lumped capacitance behavior for the rotor, the time rate of change of the rotor temperature is proportional to the instantaneous heat flux from the rotor surface. In either orientation, the quenching process begins at an initial rotor temperature associated with film boiling (see Fig. 10.4 and the RHS schematic).

(a) For Orientation A, the rotor temperature versus time is shown in the sketch below. In the film boiling regime, the slope of the  $T(t)$  curve continually decreases as the boiling heat flux decreases until the Leidenfrost point (Point D) is reached. Between Points D and C, transition boiling occurs and the heat flux increases as the rotor temperature decreases until the critical heat flux value (Point C) is reached. Point C corresponds to a local maximum rotor cooling rate. As the rotor continues to cool, the heat flux continues to decrease throughout the nucleate boiling regime until Point A is reached, corresponding to the curtailment of boiling, the onset of free convection cooling, and very slow decreases in the rotor temperature with time.

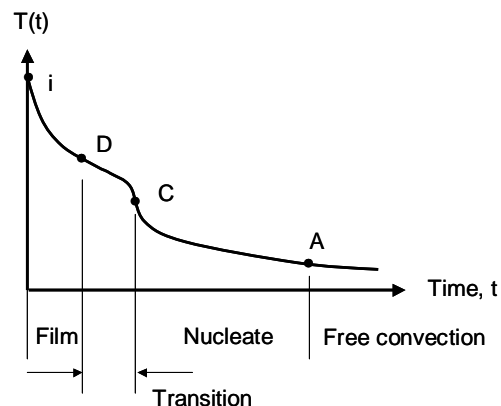

(b) For Orientation A, vapor rises unimpeded from the vicinity of the rotor. For Orientation B, however, the rotor obstructs the movement of vapor away from the bottom surface of the rotor. Hence, even in the nucleate boiling regime, an insulating vapor blanket would tend to form on the bottom surface, resulting in slower cooling relative to Orientation A.

### PROBLEM 10.30

**KNOWN:** Steel bar upon removal from a furnace immersed in water bath.

**FIND:** Initial heat transfer rate from bar.

**SCHEMATIC:**

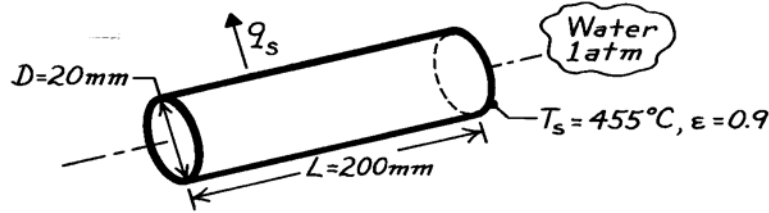

**ASSUMPTIONS:** (1) Uniform bar surface temperature, (2) Film pool boiling conditions.

**PROPERTIES:** Table A-6, Water, liquid (1 atm,  $T_{\text{sat}} = 100^\circ\text{C}$ ):  $\rho_\ell = 957.9 \text{ kg/m}^3$ ,  $h_{\text{fg}} = 2257 \text{ kJ/kg}$ ; Table A-4, Water, vapor ( $T_f = (T_s + T_{\text{sat}})/2 = 550\text{K}$ ):  $\rho_v = 0.4005 \text{ kg/m}^3$ ,  $c_{p,v} = 1997 \text{ J/kg}\cdot\text{K}$ ,  $\nu_v = 47.04 \times 10^{-6} \text{ m}^2/\text{s}$ ,  $k_v = 0.0379 \text{ W/m}\cdot\text{K}$ .

**ANALYSIS:** The total heat transfer rate from the bar at the instant of time it is removed from the furnace and immersed in the water is

$$q_s = \bar{h} A_s (T_s - T_{\text{sat}}) = \bar{h} A_s \Delta T_e \quad (1)$$

where  $\Delta T_e = 455 - 100 = 355\text{K}$ . According to the boiling curve of Figure 10.4, with such a high  $\Delta T_e$ , film pool boiling will occur. From Eq. 10.9 or 10.10,

$$\bar{h}^{4/3} = \bar{h}_{\text{conv}}^{4/3} + \bar{h}_{\text{rad}} \cdot \bar{h}^{1/3} \quad \text{or} \quad \bar{h} = \bar{h}_{\text{conv}} + \frac{3}{4} \bar{h}_{\text{rad}} \quad (\text{if } h_{\text{conv}} > h_{\text{rad}}). \quad (2)$$

To estimate the convection coefficient, use Eq. 10.8,

$$\overline{\text{Nu}}_D = \frac{\bar{h}_{\text{conv}} D}{k_v} = C \left[ \frac{g(\rho_\ell - \rho_v) h'_{\text{fg}} D^3}{\nu_v k_v \Delta T_e} \right]^{1/4} \quad (3)$$

where  $C = 0.62$  for the horizontal cylinder and  $h'_{\text{fg}} = h_{\text{fg}} + 0.8 c_{p,v} (T_s - T_{\text{sat}})$ . Find

$$\bar{h}_{\text{conv}} = \frac{0.0379 \text{ W/m}\cdot\text{K}}{0.020 \text{ m}} \cdot 0.62 \left[ \frac{9.8 \text{ m/s}^2 (957.9 - 0.4005) \text{ kg/m}^3 \left[ 2257 \times 10^3 + 0.8 \times 1997 \times 355 \right] \text{ J/kg} (0.020 \text{ m})^3}{(47.04 \times 10^{-6}) \text{ m}^2/\text{s} \times 0.0379 \text{ W/m}\cdot\text{K} \times 355 \text{ K}} \right]^{1/4}$$

$$\bar{h}_{\text{conv}} = 159 \text{ W/m}^2 \cdot \text{K}.$$

To estimate the radiation coefficient, use Eq. 10.11,

$$\bar{h}_{\text{rad}} = \frac{\varepsilon \sigma (T_s^4 - T_{\text{sat}}^4)}{T_s - T_{\text{sat}}} = \frac{0.9 \times 5.67 \times 10^{-8} \text{ W/m}^2 \cdot \text{K}^4 (728^4 - 373^4) \text{ K}^4}{355 \text{ K}} = 37.6 \text{ W/m}^2 \cdot \text{K}.$$

Substituting numerical values into the simpler form of Eq. (2), find

$$\bar{h} = (159 + (3/4)37.6) \text{ W/m}^2 \cdot \text{K} = 187 \text{ W/m}^2 \cdot \text{K}.$$

Using Eq. (1), the heat rate, with  $A_s = \pi D L$ , is

$$q_s = 187 \text{ W/m}^2 \cdot \text{K} (\pi \times 0.020 \text{ m} \times 0.200 \text{ m}) \times 355 \text{ K} = 835 \text{ W}. \quad <$$

**COMMENTS:** For these conditions, the combined radiation and convection heat transfer coefficient is 18% larger than the convection coefficient alone.



### PROBLEM 10.31

**KNOWN:** Electrical conductor with prescribed surface temperature immersed in water.

**FIND:** (a) Power dissipation per unit length,  $q'_s$  and (b) Compute and plot  $q'_s$  as a function of surface temperature  $250 \leq T_s \leq 650^\circ\text{C}$  for conductor diameters of 1.5, 2.0, and 2.5 mm; separately plot the percentage contribution of radiation as a function of  $T_s$ .

**SCHEMATIC:**

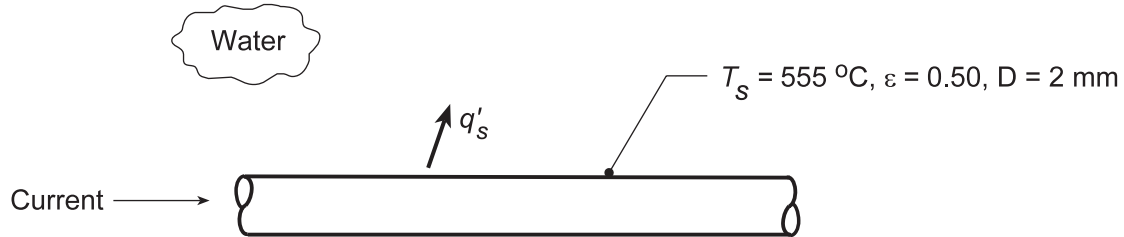

**ASSUMPTIONS:** (1) Steady-state conditions, (2) Water saturated at 1 atm, (3) Film pool boiling.

**PROPERTIES:** Table A-6, Water, liquid (1 atm,  $T_{\text{sat}} = 100^\circ\text{C}$ ):  $\rho_\ell = 957.9 \text{ kg/m}^3$ ,  $h_{\text{fg}} = 2257 \text{ kJ/kg}$ ; Table A-4, Water, vapor ( $T_f = (T_s + T_{\text{sat}}) / 2 = 600 \text{ K}$ ):  $\rho_v = 0.3652 \text{ kg/m}^3$ ,  $c_{p,v} = 2026 \text{ J/kg}\cdot\text{K}$ ,  $\nu_v = 56.60 \times 10^{-6} \text{ m}^2/\text{s}$ ,  $k_v = 0.0422 \text{ W/m}\cdot\text{K}$ .

**ANALYSIS:** (a) The heat rate per unit length due to electrical power dissipation is

$$q'_s = \frac{q_s}{\ell} = \bar{h} \frac{A_s}{\ell} (T_s - T_{\text{sat}}) = \bar{h} \pi D \Delta T_e$$

where  $\Delta T_e = (555 - 100)^\circ\text{C} = 455^\circ\text{C}$ . According to the boiling curve of Figure 10.4, with such a high  $\Delta T_e$ , film pool boiling will occur. From Eq 10.9 or 10.10,

$$\bar{h}^{4/3} = \bar{h}_{\text{conv}}^{4/3} + \bar{h}_{\text{rad}} \cdot \bar{h}^{1/3} \quad \text{or} \quad \bar{h} = \bar{h}_{\text{conv}} + \frac{3}{4} \bar{h}_{\text{rad}} \quad (\text{if } \bar{h}_{\text{conv}} > \bar{h}_{\text{rad}}).$$

To estimate the convection coefficient, use Eq. 10.8,

$$\overline{\text{Nu}}_D = \frac{\bar{h}_{\text{conv}} D}{k_v} = C \left[ \frac{g(\rho_\ell - \rho_v) h'_{\text{fg}} D^3}{\nu_v k_v \Delta T_e} \right]^{1/4}$$

where  $C = 0.62$  for the horizontal cylinder and  $h'_{\text{fg}} = h_{\text{fg}} + 0.8c_{p,v} (T_s - T_{\text{sat}})$ . Find

$$\bar{h}_{\text{conv}} = \frac{0.0422 \text{ W/m}\cdot\text{K}}{0.002 \text{ m}} \times 0.62 \left[ \frac{9.8 \text{ m/s}^2 (957.9 - 0.3652) \text{ kg/m}^3 \left[ 2257 \times 10^3 + 0.8 \times 2026 \times 455 \right] \text{ J/kg} (0.002 \text{ m})^3}{(56.60 \times 10^{-6}) \text{ m}^2/\text{s} \times 0.0422 \text{ W/m}\cdot\text{K} \times 455 \text{ K}} \right]^{1/4}$$

$$\bar{h}_{\text{conv}} = 279 \text{ W/m}^2 \cdot \text{K}.$$

To estimate the radiation coefficient, use Eq. 10.11.

$$\bar{h}_{\text{rad}} = \frac{\varepsilon \sigma (T_s^4 - T_{\text{sat}}^4)}{T_s - T_{\text{sat}}} = \frac{0.5 \times 5.67 \times 10^{-8} \text{ W/m}^2 \cdot \text{K}^4 (828^4 - 373^4) \text{ K}^4}{455 \text{ K}} = 28 \text{ W/m}^2 \cdot \text{K}.$$

Since  $\bar{h}_{\text{conv}} > \bar{h}_{\text{rad}}$ , the simpler form of Eq. 10.10 is appropriate. Find,

$$\bar{h} = (279 + (3/4) \times 28) \text{ W/m}^2 \cdot \text{K} = 300 \text{ W/m}^2 \cdot \text{K}$$

Continued...

### PROBLEM 10.31 (Cont.)

The heat rate is

$$q' = 300 \text{ W/m}^2 \cdot \text{K} \times \pi(0.002\text{m}) \times 455 \text{ K} = 858 \text{ kW/m.}$$

<

(b) Using the *IHT Correlation Tool, Boiling, Film Pool Boiling*, combined with the *Properties Tool for Water Vapor*, the heat rate,  $q'$ , was calculated as a function of the surface temperature,  $T_s$ , for conductor diameters of 1.5, 2.0, and 2.5 mm. Also plotted below is the ratio (%) of  $q'_{\text{rad}}/q'$  as a function of surface temperature.

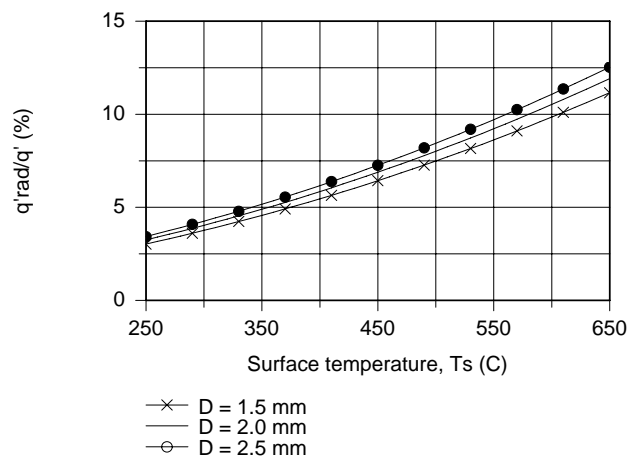
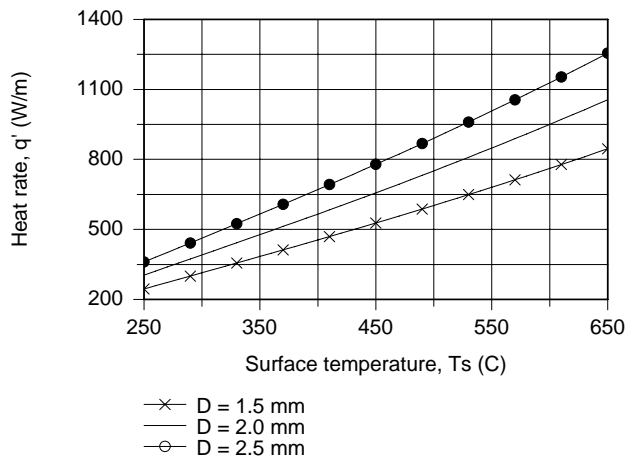

From the  $q'$  vs.  $T_s$  plot, note that the heat rate increases with increasing surface temperature, and as expected, the heat rate increases with increasing diameter. From the  $q'_{\text{rad}}/q'$  vs.  $T_s$  plot, the maximum contribution by radiation is 14%, and occurs at the maximum surface temperature.

### PROBLEM 10.32

**KNOWN:** Diameter and emissivity of heated platinum wire in saturated water at atmospheric pressure. Water vapor properties at film temperature.

**FIND:** Heat flux from wire when it is at its melting temperature and corresponding centerline temperature.

**SCHEMATIC:**

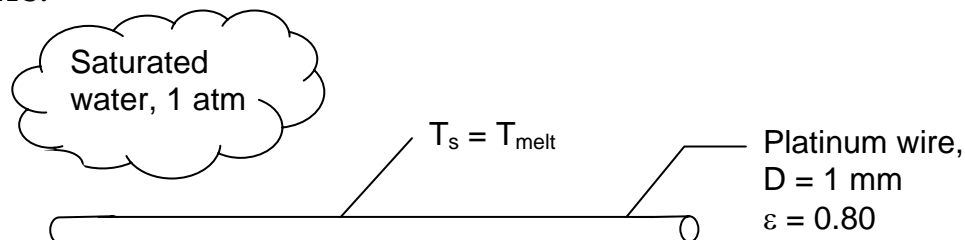

**ASSUMPTIONS:** (1) Steady-state conditions, (2) Film pool boiling occurs.

**PROPERTIES:** Table A.1, Platinum:  $T_{\text{melt}} = 2045 \text{ K}$ ,  $k_p = 99.4 \text{ W/m}\cdot\text{K}$ . Table A.6, Saturated water, liquid ( $T_{\text{sat}} = 100^\circ\text{C}$ , 1 atm):  $\rho_\ell = 957.9 \text{ kg/m}^3$ ,  $h_{fg} = 2257 \text{ kJ/kg}$ ; Water vapor at film temperature ( $T_f = 1209 \text{ K}$ , 1 atm), given:  $\rho_v = 0.189 \text{ kg/m}^3$ ,  $c_{p,v} = 2404 \text{ J/kg}\cdot\text{K}$ ,  $\nu_v = 231 \times 10^{-6} \text{ m}^2/\text{s}$ ,  $k_v = 0.113 \text{ W/m}\cdot\text{K}$ .

**ANALYSIS:** The heat flux is

$$q_s'' = \bar{h}(T_s - T_{\text{sat}}) = \bar{h}\Delta T_e \quad (1)$$

where  $\Delta T_e = (2045 - 373)\text{K} = 1672$  is indicative of film boiling. From Eq. 10.9,

$$\bar{h}^{4/3} = \bar{h}_{\text{conv}}^{4/3} + \bar{h}_{\text{rad}}\bar{h}^{1/3}$$

For  $\bar{h}_{\text{conv}}$  use Eq. 10.8 with  $C = 0.62$  for a horizontal cylinder,

$$\text{Nu}_D = \frac{\bar{h}_{\text{conv}}D}{k_v} = C \left[ \frac{g(\rho_\ell - \rho_v)h'_{fg}D^3}{\nu_v k_v (T_s - T_{\text{sat}})} \right]^{1/4}$$

$$\frac{\bar{h}_{\text{conv}} \times 0.001 \text{ m}}{0.113 \text{ W/m}\cdot\text{K}} = 0.62 \left[ \frac{9.8 \text{ m/s}^2 (957.9 - 0.189) \text{ kg/m}^3 \times 5473 \times 10^3 \text{ J/kg} (0.001 \text{ m})^3}{231 \times 10^{-6} \text{ m}^2/\text{s} \times 0.113 \text{ W/m}\cdot\text{K} (2045 - 373) \text{ K}} \right]^{1/4}$$

$$\bar{h}_{\text{conv}} = 410 \text{ W/m}^2 \cdot \text{K}$$

where

$h'_{fg} = h_{fg} + 0.8c_{p,v}(T_s - T_{\text{sat}}) = 2257 \text{ kJ/kg} + 0.8 \times 2.404 \text{ kJ/kg}\cdot\text{K} (2045 - 373) \text{ K} = 5473 \text{ kJ/kg}$ . To estimate the radiation coefficient, use Eq. 10.11,

$$\bar{h}_{\text{rad}} = \frac{\varepsilon\sigma(T_s^4 - T_{\text{sat}}^4)}{T_s - T_{\text{sat}}} = \frac{0.80 \times 5.67 \times 10^{-8} \text{ W/m}^2 \cdot \text{K}^4 (2045^4 - 373^4) \text{ K}^4}{(2045 - 373) \text{ K}} = 474 \text{ W/m}^2 \cdot \text{K}.$$

Continued...

### PROBLEM 10.32 (Cont.)

Then Eq. 10.9 becomes

$$\bar{h}^{4/3} = \left(410 \text{ W/m}^2 \cdot \text{K}\right)^{4/3} + \left(474 \text{ W/m}^2 \cdot \text{K}\right) \bar{h}^{1/3}$$

Solving iteratively, find  $\bar{h} = 802 \text{ W/m}^2 \cdot \text{K}$ . Then, using Eq. (1), find

$$q_s'' = 802 \text{ W/m}^2 \cdot \text{K} (2045 - 373) \text{ K} = 1.34 \text{ MW/m}^2. \quad <$$

The volumetric heat generation rate due to the electrical current can be found from the energy balance,

$$q_s'' \pi D = \dot{q} \pi D^2 / 4 \quad \dot{q} = 4q_s'' / D = 4 \times 1.34 \text{ MW/m}^2 / 0.001 \text{ m} = 5.36 \times 10^9 \text{ W/m}^3$$

From Eq. 3.59,

$$T_c = T(r=0) = \frac{\dot{q} r_0^2}{4k} + T_s$$

$$= \frac{5.36 \times 10^9 \text{ W/m}^2 \times (0.0005 \text{ m})^2}{4 \times 99.4 \text{ W/m} \cdot \text{K}} + 2045 \text{ K} = 2048 \text{ K} \quad <$$

**COMMENTS:** (1) The film boiling heat flux which causes the platinum wire to melt is not much greater than the critical heat flux. A system which was operating near the critical heat flux and underwent a small, unintentional increase in electrical power could cause destruction of the wire. (2) Radiation accounts for 60% of the heat flux from the wire at burnout. (3) Radial temperature differences in the wire are small because of the small radius and large thermal conductivity.

### PROBLEM 10.33

**KNOWN:** Heater element of 5-mm diameter maintained at a surface temperature of 350°C when immersed in water under atmospheric pressure; element sheath is stainless steel with a mechanically polished finish having an emissivity of 0.25.

**FIND:** (a) The electrical power dissipation and the rate of evaporation per unit length; (b) If the heater element were operated at the same power dissipation rate in the nucleate boiling regime, what temperature would the surface achieve? Calculate the rate of evaporation per unit length for this operating condition; and (c) Make a sketch of the boiling curve and represent the two operating conditions of parts (a) and (b). Compare the results of your analysis. If the heater element is operated in the power-controlled mode, explain how you would achieve these two operating conditions beginning with a cold element.

**SCHEMATIC:**

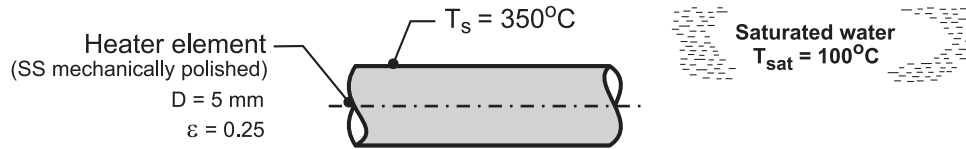

**ASSUMPTIONS:** (1) Steady-state conditions, and (2) Water exposed to standard atmospheric pressure and uniform temperature,  $T_{\text{sat}}$ .

**PROPERTIES:** Table A-6, Saturated water, liquid (100°C):  $\rho_\ell = 957.9 \text{ kg/m}^3$ ,  $c_{p,\ell} = 4217 \text{ J/kg}\cdot\text{K}$ ,  $\mu_\ell = 279 \times 10^{-6} \text{ N}\cdot\text{s/m}^2$ ,  $\text{Pr}_\ell = 1.76$ ,  $h_{\text{fg}} = 2257 \text{ kJ/kg}$ ,  $h'_{\text{fg}} = h_{\text{fg}} + 0.80 c_{p,v} (T_s - T_{\text{sat}}) = 2654 \text{ kJ/kg}$ ,  $\sigma = 58.9 \times 10^{-3} \text{ N/m}$ ; Saturated water, vapor (100°C):  $\rho_v = 0.5955 \text{ kg/m}^3$ ; Table A-4, Water vapor ( $T_f \approx 500 \text{ K}$ ):  $\rho_v = 0.4405 \text{ kg/m}^3$ ,  $c_{p,v} = 1985 \text{ J/kg}\cdot\text{K}$ ,  $k_v = 0.0339 \text{ W/m}\cdot\text{K}$ ,  $\nu_v = 38.68 \times 10^{-6} \text{ m}^2/\text{s}$ .

**ANALYSIS:** (a) Since  $\Delta T_e > 120^\circ\text{C}$ , the element is operating in the *film-boiling* (FB) regime. The electrical power dissipation per unit length is

$$q'_s = \bar{h}(\pi D)(T_s - T_{\text{sat}}) \quad (1)$$

where the total heat transfer coefficient is

$$\bar{h}^{4/3} = \bar{h}_{\text{conv}}^{4/3} + \bar{h}_{\text{rad}} \bar{h}^{1/3} \quad (2)$$

The convection coefficient is given by the correlation, Eq. 10.8, with  $C = 0.62$ ,

$$\frac{\bar{h}_{\text{conv}} D}{k_v} = C \left[ \frac{g(\rho_\ell - \rho_v) h'_{\text{fg}} D^3}{\nu_v k_v (T_s - T_{\text{sat}})} \right]^{1/4} \quad (3)$$

$$\bar{h}_{\text{conv}} = \frac{0.339 \text{ W/m}\cdot\text{K}}{0.005 \text{ m}} (0.62) \left[ \frac{9.8 \text{ m/s}^2 (833.9 - 0.4405) \text{ kg/m}^3 \times 2.654 \times 10^6 \text{ J/kg}\cdot\text{K} (0.005 \text{ m})^3}{38.68 \times 10^{-6} \text{ m}^2/\text{s} \times 0.0339 \text{ W/m}\cdot\text{K} (350 - 100) \text{ K}} \right]^{1/4}$$

$$\bar{h}_{\text{conv}} = 225 \text{ W/m}^2\cdot\text{K}$$

The radiation coefficient, Eq. (10.11), with  $\sigma = 5.67 \times 10^{-8} \text{ W/m}^2\cdot\text{K}^4$ , is

Continued ...

**PROBLEM 10.33 (Cont.)**

$$\bar{h}_{\text{rad}} = \frac{\varepsilon\sigma(T_s^4 - T_{\text{sat}}^4)}{(T_s - T_{\text{sat}})}$$

$$\bar{h}_{\text{rad}} = \frac{0.25\sigma(623^4 - 373^4)\text{K}^4}{(350 - 100)\text{K}} = 7.4 \text{ W/m}^2 \cdot \text{K}$$

Substituting numerical values into Eq. (2) for  $\bar{h}$ , and into Eq. (1) for  $q'_s$ , find

$$\bar{h} = 231 \text{ W/m}^2 \cdot \text{K}$$

$$q'_s = 231 \text{ W/m}^2 \cdot \text{K} (\pi \times 0.005 \text{ m})(350 - 100)\text{K} = 907 \text{ W/m} \quad <$$

$$q''_s = q'_s / \pi D = 57.8 \text{ kW/m}^2$$

The evaporation rate per unit length is

$$\dot{m}'_b = q'_s / h_{\text{fg}} = 1.4 \text{ kg/h} \cdot \text{m} \quad <$$

(b) For the same heat flux,  $q''_s = 57.8 \text{ kW/m}^2$ , using the Rohsenow correlation for the *nucleate boiling* (NB) regime, find  $\Delta T_e$ , and hence  $T_s$ .

$$q''_s = \mu_\ell h_{\text{fg}} \left[ \frac{g(\rho_\ell - \rho_v)}{\sigma} \right]^{1/2} \left( \frac{c_{p,\ell} \Delta T_e}{C_{s,f} h_{\text{fg}} \text{Pr}_\ell^n} \right)^3$$

where, from Table 10.1, for stainless steel mechanically polished finish with water,  $C_{s,f} = 0.0132$  and  $n = 1.0$ .

$$\begin{aligned} 57.8 \times 10^3 \text{ W/m}^2 &= 279 \times 10^{-6} \text{ N} \cdot \text{s/m}^2 \times 2.257 \times 10^6 \text{ J/kg} \\ &\times \left[ \frac{9.8 \text{ m/s}^2 (957.9 - 0.5955) \text{ kg/m}^3}{58.9 \times 10^{-3} \text{ N/m}} \right]^{1/2} \\ &\times \left( \frac{4217 \text{ J/kg} \cdot \text{K} \times \Delta T_e}{0.0132 \times 2.257 \times 10^6 \text{ J/kg} \times 1.76} \right)^3 \end{aligned}$$

$$\Delta T_e = T_s - T_{\text{sat}} = 7.6 \text{ K}$$

$$T_s = 107.6^\circ\text{C} \quad <$$

The evaporation rate per unit length is

$$\dot{m}'_b = q''_s (\pi D) h_{\text{fg}} = 1.4 \text{ kg/h} \cdot \text{m} \quad <$$

Continued ...

### PROBLEM 10.33 (Cont.)

(c) The two operating conditions are shown on the boiling curve, which is fashioned after Figure 10.4. For FB the surface temperature is  $T_s = 350^\circ\text{C}$  ( $\Delta T_e = 250^\circ\text{C}$ ). The element can be operated at NB with the same heat flux,  $q_s'' = 57.8 \text{ kW/m}^2$ , with a surface temperature of  $T_s = 108^\circ\text{C}$  ( $\Delta T_e = 8^\circ\text{C}$ ). Since the heat fluxes are the same for both conditions, the evaporation rates are the same.

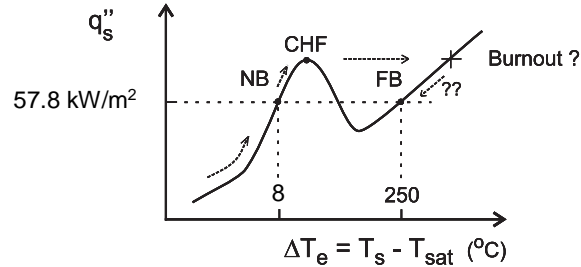

If the element is cold, and operated in a power-controlled mode, the element would be brought to the NB condition following the arrow shown next to the boiling curve near  $\Delta T_e = 0$ . If the power is increased beyond that for the NB point, the element will approach the critical heat flux (CHF) condition. If  $q_s''$  is increased beyond  $q_{s''\text{max}}$ , the temperature of the element will increase abruptly, and the burnout condition will likely occur. If burnout does not occur, reducing the heat flux would allow the element to reach the FB point.

### PROBLEM 10.34

**KNOWN:** Thickness and thermal conductivity of silicon chip. Properties of saturated fluorocarbon boiling on top of chip. Nucleate boiling constants. Surge in heat flux causes film boiling, then returns to 30% of critical heat flux.

**FIND:** (a) Boiling regime when heat flux returns to original value. (b) How much clock speed must be reduced to return to nucleate boiling regime.

**SCHEMATIC:**

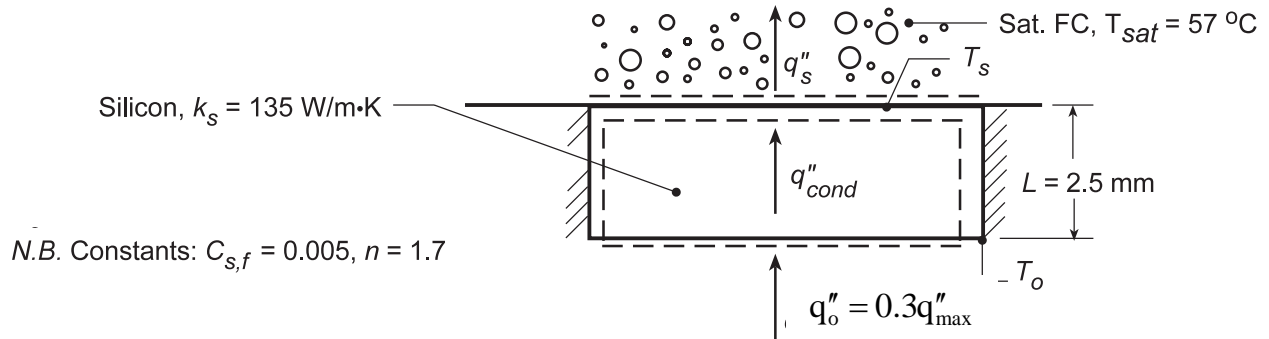

**ASSUMPTIONS:** (1) Steady-state conditions, (2) Uniform heat flux and adiabatic sides, hence one-dimensional conduction in chip, (3) Constant properties.

**PROPERTIES:** Saturated fluorocarbon (given):  $c_{p,\ell} = 1100 \text{ J/kg}\cdot\text{K}$ ,  $h_{fg} = 84,400 \text{ J/kg}$ ,  $\rho_\ell = 1619.2 \text{ kg/m}^3$ ,  $\rho_v = 13.4 \text{ kg/m}^3$ ,  $\sigma = 8.1 \times 10^{-3} \text{ kg/s}^2$ ,  $\mu_\ell = 440 \times 10^{-6} \text{ kg/m}\cdot\text{s}$ ,  $\text{Pr}_\ell = 9.01$ .

**ANALYSIS:** (a) We begin by calculating the critical heat flux from Eq. 10.6 with  $C = 0.149$  for a large horizontal plate.

$$\begin{aligned}
 q''_{\max} &= 0.149 h_{fg} \rho_v \left[ \frac{\sigma g (\rho_\ell - \rho_v)}{\rho_v^2} \right]^{1/4} \\
 &= 0.149 \times 84,400 \text{ J/kg} \times 13.4 \text{ kg/m}^3 \times \left[ \frac{8.1 \times 10^{-3} \text{ kg/s}^2 \times 9.8 \text{ m/s}^2 (1619.2 - 13.4) \text{ kg/m}^3}{(13.4 \text{ kg/m}^3)^2} \right]^{1/4} \\
 &= 1.55 \times 10^5 \text{ W/m}^2
 \end{aligned}$$

Thus the design heat flux is  $q''_{\text{des}} = 0.3q''_{\max} = 4.64 \times 10^4 \text{ W/m}^2$ . When a power surge causes film boiling and then the heat flux returns to this value, the regime will still be film boiling if this value exceeds the minimum heat flux. However, if it drops below the minimum heat flux it will return to nucleate boiling. The minimum heat flux can be calculated from Eq. 10.7,

$$q''_{\min} = 0.09 h_{fg} \rho_v \left[ \frac{\sigma g (\rho_\ell - \rho_v)}{(\rho_\ell + \rho_v)^2} \right]^{1/4}$$

Continued...



**PROBLEM 10.34 (Cont.)**

$$q''_{\min} = 0.09 \times 84,400 \text{ J/kg} \times 13.4 \text{ kg/m}^3 \times \left[ \frac{8.1 \times 10^{-3} \text{ kg/s}^2 \times 9.8 \text{ m/s}^2 (1619.2 - 13.4) \text{ kg/m}^3}{(1619.2 + 13.4 \text{ kg/m}^3)^2} \right]^{1/4}$$
$$= 8.46 \times 10^3 \text{ W/m}^2$$

Thus  $q''_{\text{des}} > q''_{\min}$  and the chip will operate in the film boiling regime after the heat flux returns to the design value. <

(b) The heat flux must be reduced below  $q''_{\min} = 8.46 \times 10^3 \text{ W/m}^2$  in order to return to the nucleate boiling regime. That is, it must be reduced to 18% of the design value, or a reduction of 82%. <

**COMMENTS:** In addition to having limited capability to cool VLSI chips (see Solution to Problem 10.23), boiling limits their reliability since, for all practical purposes, the chip must cease functioning in order to return to a safe operating condition.

### PROBLEM 10.35

**KNOWN:** Cylinder of 120 mm diameter at 1000K quenched in saturated water at 1 atm

**FIND:** Describe the quenching process and estimate the maximum heat removal rate per unit length during cooling.

**SCHEMATIC:**

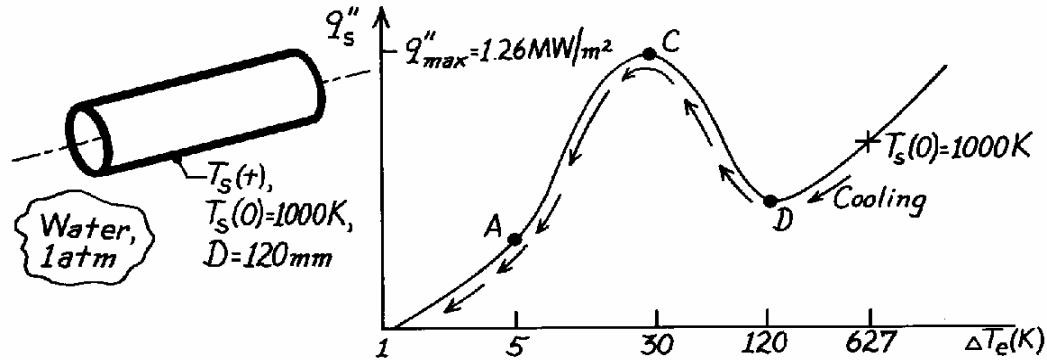

**ASSUMPTIONS:** Water exposed to 1 atm pressure,  $T_{\text{sat}} = 100^\circ\text{C}$ .

**ANALYSIS:** At the start of the quenching process, the surface temperature is  $T_s(0) = 1000\text{K}$ . Hence,  $\Delta T_e = T_s - T_{\text{sat}} = 1000\text{K} - 373\text{K} = 627\text{K}$ , and from the typical boiling curve of Figure 10.4, film boiling occurs, with  $q'' < q''_{\text{max}}$ .

As the cylinder temperature decreases,  $\Delta T_e$  decreases, and the cooling process follows the boiling curve sketched above. The cylinder boiling process passes through the Leidenfrost point D, into the transition or unstable boiling regime ( $D \rightarrow C$ ).

At point C, the boiling heat flux has reached a maximum,  $q''_{\text{max}} = 1.26\text{ MW/m}^2$  (see Example 10.1). Hence, the heat rate per unit length of the cylinder is

$$q'_s = q'_{\text{max}} = q''_{\text{max}} (\pi D) = 1.26\text{ MW/m}^2 [\pi (0.120\text{m})] = 0.475\text{ MW/m}. \quad <$$

As the cylinder cools further, nucleate boiling occurs ( $C \rightarrow A$ ) and the heat rate drops rapidly. Finally, at point A, boiling no longer is present and the cylinder is cooled by free convection.

**COMMENTS:** Why doesn't the quenching process follow the cooling curve of Figure 10.3?

### PROBLEM 10.36

**KNOWN:** Horizontal platinum wire of diameter of 1 mm, emissivity of 0.25, and surface temperature of 800 K in saturated water at 1 atm pressure.

**FIND:** (a) Surface heat flux,  $q_s''$ , when the surface temperature is  $T_s = 800$  K and (b) Compute and plot on log-log coordinates the heat flux as a function of the excess temperature,  $\Delta T_e = T_s - T_{sat}$ , for the range  $150 \leq \Delta T_e \leq 550$  K for emissivities of 0.1, 0.25, and 0.95; separately plot the percentage contribution of radiation as a function of  $\Delta T_e$ .

**SCHEMATIC:**

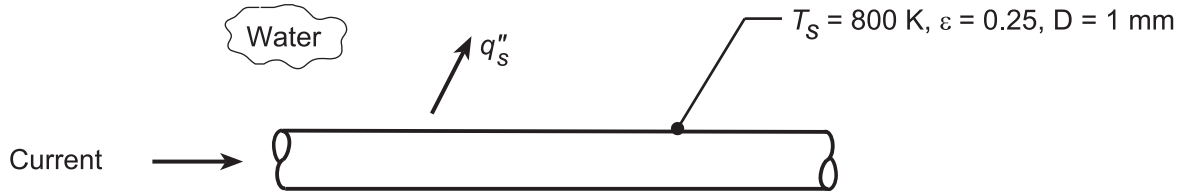

**ASSUMPTIONS:** (1) Steady-state conditions, (2) Film pool boiling.

**PROPERTIES:** Table A.6, Saturated water, liquid ( $T_{sat} = 100^\circ\text{C}$ , 1 atm):  $\rho_\ell = 957.9$  kg/m<sup>3</sup>,  $h_{fg} = 2257$  kJ/kg; Table A.4, Water, vapor ( $T_f = (T_s + T_{sat})/2 = (800 + 373)\text{K}/2 = 587$  K):  $\rho_v = 0.3744$  kg/m<sup>3</sup>,  $c_{p,v} = 2018$  J/kg·K,  $\nu_v = 54.11 \times 10^{-6}$  m<sup>2</sup>/s,  $k_v = 41.1 \times 10^{-3}$  W/m·K.

**ANALYSIS:** (a) The heat flux is

$$q_s'' = \bar{h}(T_s - T_{sat}) = \bar{h}\Delta T_e$$

where  $\Delta T_e = (800 - 373)\text{K} = 427$  is indicative of film boiling. From Eq. 10.9 or 10.10,

$$\bar{h}^{4/3} = \bar{h}_{conv}^{4/3} + \bar{h}_{rad}\bar{h}^{-1/3} \quad \text{or} \quad \bar{h} = \bar{h}_{conv} + (3/4)\bar{h}_{rad}$$

if  $\bar{h}_{rad} < \bar{h}_{conv}$ . Use Eq. 10.8 with  $C = 0.62$  for a horizontal cylinder,

$$\overline{\text{Nu}}_D = \frac{\bar{h}_{conv}D}{k_v} = C \left[ \frac{g(\rho_\ell - \rho_v)h'_{fg}D^3}{\nu_v k_v (T_s - T_{sat})} \right]^{1/4}$$

$$\frac{\bar{h}_{conv} \times 0.001 \text{ m}}{41.1 \times 10^{-3} \text{ W/m}\cdot\text{K}} = 0.62 \left[ \frac{9.8 \text{ m/s}^2 (957.9 - 0.3744) \text{ kg/m}^3 \times 2946 \text{ kJ/kg} (0.001 \text{ m})^3}{(54.11 \times 10^{-6} \text{ m}^2/\text{s}) \times 0.0411 \text{ W/m}\cdot\text{K} (800 - 373) \text{ K}} \right]^{1/4}$$

$$\bar{h}_{conv} = 333 \text{ W/m}^2 \cdot \text{K}$$

where  $h'_{fg} = h_{fg} + 0.8c_{p,v}(T_s - T_{sat}) = 2257 \text{ kJ/kg} + 0.8 \times 2018 \text{ J/kg}\cdot\text{K} (800 - 373) \text{ K} = 2946 \text{ kJ/kg}$ . To estimate the radiation coefficient, use Eq. 10.11,

$$\bar{h}_{rad} = \frac{\epsilon\sigma(T_s^4 - T_{sat}^4)}{T_s - T_{sat}} = \frac{0.25\sigma(800^4 - 373^4) \text{ K}^4}{(800 - 373) \text{ K}} = 13.0 \text{ W/m}^2 \cdot \text{K}.$$

Since  $\bar{h}_{rad} < \bar{h}_{conv}$ , use the simpler expression,

$$\bar{h} = 333 \text{ W/m}^2 \cdot \text{K} + (3/4)13.0 \text{ W/m}^2 \cdot \text{K} = 343 \text{ W/m}^2 \cdot \text{K}.$$

Using the rate equation, find

Continued...

**PROBLEM 10.36 (Cont.)**

$$q_s'' = 343 \text{ W/m}^2 \cdot \text{K} (800 - 373) \text{ K} = 146 \text{ kW/m}^2.$$

<

b) Using the *IHT Correlation Tool, Boiling, Film Pool Boiling*, combined with the *Properties Tool for Water Vapor*, the heat flux,  $q_s''$ , was calculated as a function of the surface temperature,  $\Delta T_e$ , for emissivities of 0.1, 0.25, and 0.95. Also plotted below is the ratio (%) of  $q_{\text{rad}}''/q_s''$  as a function of  $\Delta T_e$ .

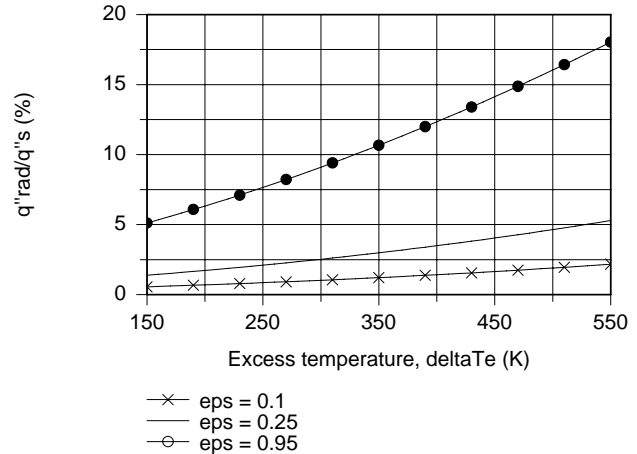
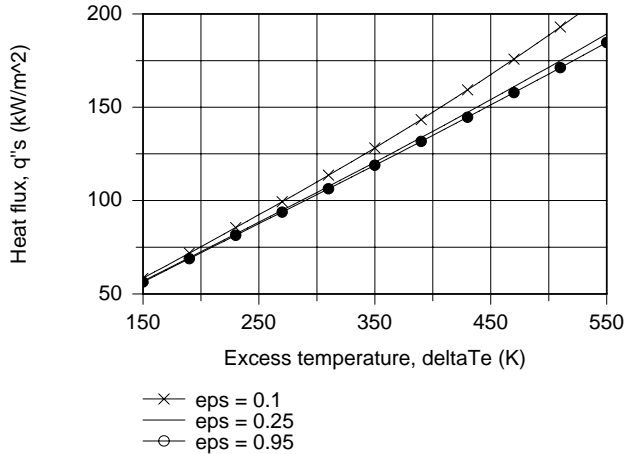

From the  $q_s''$  vs.  $\Delta T_e$  plot, note that the heat flux increases with increasing excess temperature and increasing emissivity. The heat flux falls between the minimum heat flux (Liedenfrost point) of  $18.9 \text{ kW/m}^2$  and the critical heat flux,  $1.26 \text{ MW/m}^2$  (see Example 10.1 for these values), however for sufficiently large excess temperature, the film boiling heat flux will exceed the critical heat flux. From the  $q_{\text{rad}}''/q_s''$  vs.  $\Delta T_e$  plot, the maximum contribution by radiation is around 16%, and occurs at the maximum surface temperature.

**COMMENTS:** Since  $q_s'' < q_{\text{max}}'' = 1.26 \text{ MW/m}^2$ , the prescribed condition can only be achieved in power-controlled heating by first exceeding  $q_{\text{max}}''$  and then decreasing the flux to  $146 \text{ kW/m}^2$ .

### PROBLEM 10.37

**KNOWN:** Surface temperature and emissivity of strip steel.

**FIND:** Heat flux across vapor blanket.

**SCHEMATIC:**

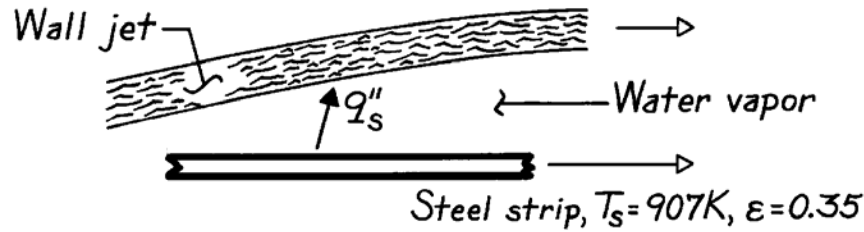

**ASSUMPTIONS:** (1) Steady-state conditions, (2) Vapor/jet interface is at  $T_{\text{sat}}$  for  $p = 1$  atm, (3) Negligible effect of jet and strip motion.

**PROPERTIES:** Table A-6, Saturated water ( $100^\circ\text{C}$ ):  $\rho_\ell = 957.9$  kg/m<sup>3</sup>,  $h_{fg} = 2257$  kJ/kg; Table A-4, Water vapor ( $T_f = 640\text{K}$ ):  $\rho_v = 0.3434$  kg/m<sup>3</sup>,  $c_{p,v} = 2050$  J/kg·K,  $\nu_v = 64.50 \times 10^{-6}$  m<sup>2</sup>/s,  $k = 0.0456$  W/m·K.

**ANALYSIS:** The heat flux is  $q_s'' = \bar{h}\Delta T_e$

where  $\Delta T_e = 907\text{ K} - 373\text{ K} = 534\text{ K}$

and  $\bar{h}^{4/3} = \bar{h}_{\text{conv}}^{4/3} + \bar{h}_{\text{rad}}\bar{h}^{1/3}$  or  $\bar{h} = \bar{h}_{\text{conv}} + (3/4)\bar{h}_{\text{rad}}$ . (1,2)

With  $h'_{fg} = h_{fg} + 0.80c_{p,v}(T_s - T_{\text{sat}}) = 3.13 \times 10^6$  J/kg

Equation 10.9 yields

$$\overline{\text{Nu}}_D = 0.62 \left[ \frac{9.8\text{ m/s}^2 (957.9 - 0.3434)\text{ kg/m}^3 (3.13 \times 10^6\text{ J/kg})(1\text{ m})^3}{64.50 \times 10^{-6}\text{ m}^2/\text{s} (0.0456\text{ W/m}\cdot\text{K})(907 - 373)\text{ K}} \right]^{1/4} = 1290.$$

Hence,

$$\bar{h}_{\text{conv}} = \overline{\text{Nu}}_D k_v / D = 1290\text{ W/m}^2 \cdot \text{K} (0.0456\text{ W/m}\cdot\text{K} / 1\text{ m}) = 58.8\text{ W/m}^2 \cdot \text{K}$$

$$\bar{h}_{\text{rad}} = \frac{\varepsilon \sigma (T_s^4 - T_{\text{sat}}^4)}{T_s - T_{\text{sat}}} = \frac{0.35 \times 5.67 \times 10^{-8}\text{ W/m}^2 \cdot \text{K}^4 (907^4 - 373^4)\text{ K}^4}{(907 - 373)\text{ K}}$$

$$\bar{h}_{\text{rad}} = 24\text{ W/m}^2 \cdot \text{K}$$

Hence,  $\bar{h} = 58.8\text{ W/m}^2 \cdot \text{K} + (3/4)(24\text{ W/m}^2 \cdot \text{K}) = 77.1\text{ W/m}^2 \cdot \text{K}$

Since  $h_{\text{conv}}$  and  $h_{\text{rad}}$  are the same order of magnitude, greater accuracy can be found by iterating on Eq.(1), which yields  $\bar{h} = 78.0\text{ W/m}^2 \cdot \text{K}$ . Then,

$$q_s'' = 78.0\text{ W/m}^2 \cdot \text{K} (907 - 373)\text{ K} = 4.16 \times 10^4\text{ W/m}^2. \quad \leftarrow$$

**COMMENTS:** The foregoing analysis is a very rough approximation to a complex problem. A more rigorous treatment is provided by Zumbrennen et al. in ASME Paper 87-WA/HT-5.

### PROBLEM 10.38

**KNOWN:** Copper sphere, 10 mm diameter, initially at a prescribed elevated temperature is quenched in a saturated (1 atm) water bath.

**FIND:** The time for the sphere to cool (a) from  $T_i = 130$  to  $110^\circ\text{C}$  and (b) from  $T_i = 550^\circ\text{C}$  to  $220^\circ\text{C}$ .

**SCHEMATIC:**

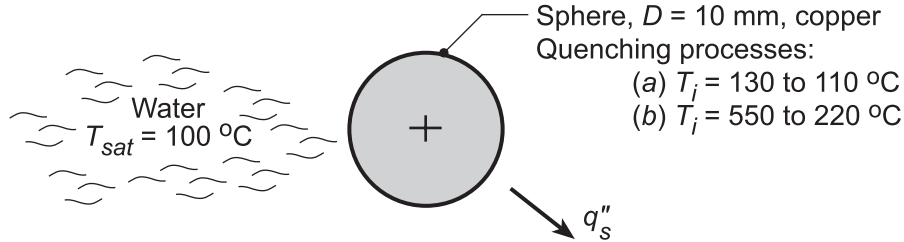

**ASSUMPTIONS:** (1) Sphere approximates lumped capacitance, (2) Water saturated at 1 atm, (3) Negligible radiation during film boiling process due to low emissivity of polished copper, (4) Average sphere temperature can be used in evaluating properties.

**PROPERTIES:** Table A-1, Copper:  $\rho = 8933 \text{ kg/m}^3$ , ( $T = (130 + 120)^\circ\text{C}/2 = 110^\circ\text{C} = 383 \text{ K}$ )  $c_p = 392 \text{ J/kg} \cdot \text{K}$ ; ( $T = (550 + 220)^\circ\text{C}/2 = 385^\circ\text{C} = 658 \text{ K}$ ,  $c_p = 422 \text{ J/kg} \cdot \text{K}$ . Table A.11, Copper (polished) :  $\varepsilon = 0.04$ , typical value; Table A.6, Water ( $T = 373 \text{ K}$ ),  $\rho_l = 1/v_f = 958 \text{ kg/m}^3$ ,  $\rho_v = 1/v_g = 0.596 \text{ kg/m}^3$ ,  $h_{fg} = 2257 \text{ kJ/kg}$ ,  $c_{p,l} = 4.217 \text{ kJ/kg} \cdot \text{K}$ ,  $\mu_l = 279 \times 10^{-6} \text{ N} \cdot \text{s/m}^2$ ,  $\sigma = 58.9 \times 10^{-3} \text{ N/m}$ ,  $Pr_l = 1.76$ ; Table A.4, Water ( $T_f = (T_s + T_{\text{sat}})/2 \approx 515 \text{ K}$ ),  $\rho_v = 1/v_g = 0.428 \text{ kg/m}^3$ ,  $c_{p,v} = 1.989 \text{ kJ/kg} \cdot \text{K}$ ,  $\nu_v = 4.13 \times 10^{-5} \text{ m}^2/\text{s}$ ,  $k_v = 0.0351 \text{ W/m} \cdot \text{K}$ .

**ANALYSIS:** For a heat transfer coefficient of the form given by Eq. 5.26, namely  $h = C(T - T_\infty)^n$ , the temperature distribution is given by Eq. 5.28. For boiling,  $T_\infty$  is replaced with  $T_{\text{sat}}$  in the expression for  $h$ . Making use of this substitution in Eq. 5.28 yields

$$\frac{\theta}{\theta_i} = \frac{T - T_{\text{sat}}}{T_i - T_{\text{sat}}} = \left[ \frac{nCA_{s,c}(T_i - T_{\text{sat}})^n}{\rho Vc} t + 1 \right]^{-1/n} \quad (1)$$

Solving for  $t$ ,

$$t = \frac{\rho Vc}{nCA_{s,c}(T_i - T_{\text{sat}})^n} \left[ \left( \frac{T - T_{\text{sat}}}{T_i - T_{\text{sat}}} \right)^{-n} - 1 \right] \quad (2)$$

(a) For cooling from  $T_i = 130^\circ$  to  $110^\circ\text{C}$ , with  $T_{\text{sat}} = 100^\circ\text{C}$ ,  $\Delta T_e = 30^\circ$  to  $10^\circ\text{C}$ . From Figure 10.4 the regime is nucleate pool boiling. From the Rohsenow correlation, Eq. 10.5,  $h = q''_s / \Delta T_e = C(\Delta T_e)^2$ , where

$$C = \mu_l h_{fg} \left[ \frac{g(\rho_l - \rho_v)}{\sigma} \right]^{1/2} \left( \frac{c_{p,l}}{C_{s,f} h_{fg} Pr_l^m} \right)^3$$

Note that exponent  $m$  has been used instead of  $n$ , to distinguish from the  $n$  exponent in Eqs. (1) and (2). From Table 10.1,  $C_{s,f} = 0.0128$ ,  $m = 1.0$ , thus

Continued...

**PROBLEM 10.38 (Cont.)**

$$C = 279 \times 10^{-6} \text{ N} \cdot \text{s/m}^2 \times 2257 \times 10^3 \text{ J/kg} \times \left[ \frac{9.81 \text{ m/s}^2 (958 \text{ kg/m}^3 - 0.596 \text{ kg/m}^3)}{58.9 \times 10^{-3} \text{ N/m}} \right]^{1/2} \\ \times \left( \frac{4217 \text{ J/kg} \cdot \text{K}}{0.0128 \times 2257 \times 10^3 \text{ J/kg} \times 1.76^{1.0}} \right)^3 = 143 \text{ W/m}^2 \cdot \text{K}^3$$

Thus, from Eq. (2), with  $n = 2$

$$t = \frac{8933 \text{ kg/m}^3 \times 395 \text{ J/kg} \cdot \text{K} \times 0.010 \text{ m/6}}{2 \times 143 \text{ W/m}^2 \cdot \text{K}^3 \times (130^\circ\text{C} - 100^\circ\text{C})^2} \left[ \left( \frac{110^\circ\text{C} - 100^\circ\text{C}}{130^\circ\text{C} - 100^\circ\text{C}} \right)^{-2} - 1 \right] = 0.18 \text{ s} <$$

(b) For cooling from  $T_i = 550^\circ$  to  $220^\circ\text{C}$ , with  $T_{\text{sat}} = 100^\circ\text{C}$ ,  $\Delta T_e = 450^\circ$  to  $120^\circ\text{C}$ . From Figure 10.4 the regime is film pool boiling. From Eq. 10.8 with  $C = 0.67$  for a sphere,  $h = C(\Delta T_e)^{-1/4}$ , where

$$C = 0.67 \frac{k_v}{D} \left[ \frac{g(\rho_l - \rho_v)h'_{fg}D^3}{\nu_v k_v} \right]^{-1/4}$$

In this expression,  $h'_{fg}$  is a function of temperature,  $h'_{fg} = h_{fg} + 0.80c_{p,v}(T - T_{\text{sat}})$ . However, since Eqs. (1) and (2) are only valid for  $C = \text{const.}$ , we evaluate  $h'_{fg}$  at the average temperature,  $T = (550 + 220)^\circ\text{C}/2 = 385^\circ\text{C}$ . This is a reasonable approximation since the temperature-dependent second term is substantially smaller than  $h_{fg}$ . Thus,

$$h'_{fg} = h_{fg} + 0.80c_{p,v}(T - T_{\text{sat}}) = 2257 \text{ kJ/kg} + 0.80 \times 1.989 \text{ kJ/kg} \cdot \text{K} \times (385 - 100)^\circ\text{C} = 2710 \text{ kJ/kg}$$

and

$$C = 0.67 \frac{0.0351 \text{ W/m} \cdot \text{K}}{0.010 \text{ m}} \left[ \frac{9.81 \text{ m/s}^2 (958 \text{ kg/m}^3 - 0.428 \text{ kg/m}^3) \times 2710 \times 10^3 \text{ J/kg} \times (0.010 \text{ m})^3}{4.13 \times 10^{-5} \text{ m}^2/\text{s} \times 0.0351 \text{ W/m} \cdot \text{K}} \right]^{1/4} \\ = 856 \text{ W/m}^2 \cdot \text{K}^{3/4}$$

Thus, from Eq. (2), with  $n = -1/4$ ,

$$t = \frac{8933 \text{ kg/m}^3 \times 422 \text{ J/kg} \cdot \text{K} \times 0.010 \text{ m/6}}{-(1/4) \times 856 \text{ W/m}^2 \cdot \text{K}^{3/4} \times (550^\circ\text{C} - 100^\circ\text{C})^{-1/4}} \left[ \left( \frac{220^\circ\text{C} - 100^\circ\text{C}}{550^\circ\text{C} - 100^\circ\text{C}} \right)^{1/4} - 1 \right] = 38.0 \text{ s} <$$

**COMMENTS:** Comparing the elapsed times for the two processes, the nucleate pool boiling process cools  $20^\circ\text{C}$  in 0.18s ( $110^\circ\text{C/s}$ ) vs.  $330^\circ\text{C}$  in 38.0s ( $8.7^\circ\text{C/s}$ ) for the film pool boiling process.

### PROBLEM 10.39

**KNOWN:** Saturated water at 1 atm is heated in cross flow with velocities 0 – 2 m/s over a 2 mm-diameter tube.

**FIND:** Plot the critical heat flux as a function of water velocity; identify the pool boiling and transition regions between the low and high velocity ranges.

**SCHEMATIC:**

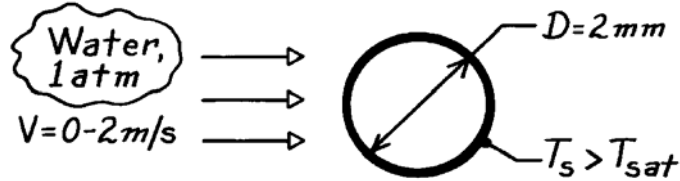

**ASSUMPTIONS:** Nucleate boiling in the presence of external forced convection.

**PROPERTIES:** Table A-6, Water (1 atm):  $T_{sat} = 100^\circ\text{C}$ ,  $\rho_\ell = 957.9 \text{ kg/m}^3$ ,  $\rho_v = 0.5955 \text{ kg/m}^3$ ,  $h_{fg} = 2257 \text{ kJ/kg}$ ,  $\sigma = 58.9 \times 10^{-3} \text{ N/m}$ .

**ANALYSIS:** The Lienhard-Eichhorn correlations for forced convection boiling with cross flow over a cylinder are appropriate for estimating  $q''_{max}$ , Eqs. 10.12 and 10.13.

*Low Velocity*

$$q''_{max} = \frac{\rho_v h_{fg}}{\pi} \left[ 1 + \left( \frac{4\sigma}{\rho_v V^2 D} \right)^{1/3} \right] V$$

$$q''_{max} = \frac{1}{\pi} 0.5955 \frac{\text{kg}}{\text{m}^3} \times 2257 \times 10^3 \frac{\text{J}}{\text{kg}} \left[ 1 + \left( \frac{4 \times 58.9 \times 10^{-3} \text{ N/m}}{0.5955 \text{ kg/m}^3 V^2 0.002 \text{ m}} \right)^{1/3} \right] V$$

$$q''_{max} = 4.2782 \times 10^5 V + 2.493 \times 10^6 V^{1/3}$$

*High Velocity*

$$q''_{max} = \frac{\rho_v h_{fg}}{\pi} \left[ \frac{1}{169} \left( \frac{\rho_\ell}{\rho_v} \right)^{3/4} + \frac{1}{19.2} \left( \frac{\rho_\ell}{\rho_v} \right)^{1/2} \left( \frac{\sigma}{\rho_v V^2 D} \right)^{1/3} \right] V$$

$$q''_{max} = \frac{1}{\pi} 0.5955 \frac{\text{kg}}{\text{m}^3} \times 2257 \times 10^3 \frac{\text{J}}{\text{kg}} \left[ \frac{1}{169} \left( \frac{957.9}{0.5955} \right)^{3/4} + \frac{1}{19.2} \left( \frac{957.9}{0.5955} \right)^{1/2} \left( \frac{58.9 \times 10^{-3} \text{ N/m}}{0.5955 \text{ kg/m}^3 V^2 0.002 \text{ m}} \right)^{1/3} \right] V$$

$$q''_{max} = 6.4299 \times 10^5 V + 3.280 \times 10^6 V^{1/3}$$

Continued ...



### PROBLEM 10.39 (Cont.)

The *transition* between the low and high velocity regions occurs when

$$q''_{\max} = \rho_v h_{fg} V \left[ \frac{0.275 \left( \frac{\rho_\ell}{\rho_v} \right)^{1/2}}{\pi} + 1 \right]$$

$$q''_{\max} = 0.5955 \frac{\text{kg}}{\text{m}^3} \times 2257 \times 10^3 \frac{\text{J}}{\text{kg}} V \left[ \frac{0.275 \left( \frac{957.9}{0.5955} \right)^{1/2}}{\pi} + 1 \right] = 6.0627 \times 10^6 V. \quad (3)$$

For pool boiling conditions when the velocity is zero, the critical heat flux must be estimated according to the correlation for the small horizontal cylinder as introduced in Problem 10.20. If the cylinder were “large,” the critical heat flux would be  $1.26 \text{ MW/m}^2$  as given by Eq. 10.6 with  $C=0.149$ . The Confinement number and correction factor are

$$Co = \frac{\sqrt{\sigma/g(\rho_\ell - \rho_v)}}{r} = \frac{\sqrt{58.9 \times 10^{-3} \text{ N/m}/9.8 \text{ m/s}^2 (957.9 - 0.5955) \text{ kg/m}^3}}{0.001 \text{ m}} = 2.51$$

$$F = 0.89 + 2.27 \exp(-3.44 Co^{-1/2}) = 1.15$$

and the critical heat flux for the “small” 2 mm cylinder is

$$q''_{\max} \Big|_{\text{pool}} = 1.15 \times 1.26 \text{ MW/m}^2 = 1.45 \text{ MW/m}^2.$$

The graph below identifies four regions: pool boiling where  $q''_{\max} = 1.45 \text{ MW/m}^2$  from  $V = 0$  to  $0.17 \text{ m/s}$  and the low velocity, transition and high velocity regimes.

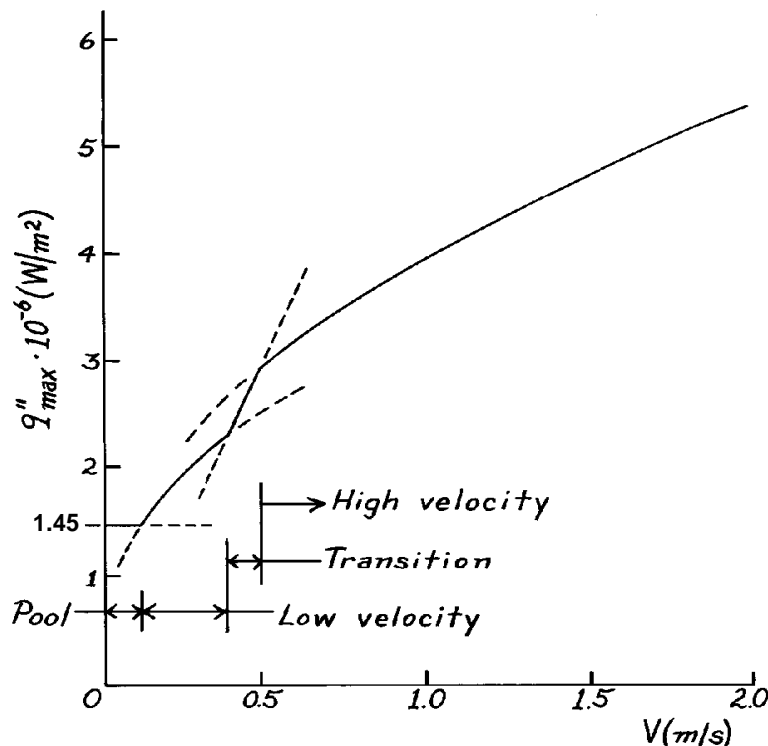

### PROBLEM 10.40

**KNOWN:** Saturated water at 1 atm and velocity 2 m/s in cross flow over a heater element of 5 mm diameter.

**FIND:** Maximum heating rate,  $q'$  [W/m].

**SCHEMATIC:**

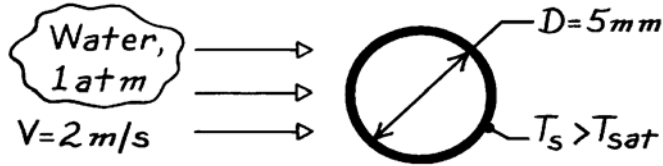

**ASSUMPTIONS:** Nucleate boiling in the presence of external forced convection.

**PROPERTIES:** Table A-6, Water (1 atm):  $T_{sat} = 100^\circ\text{C}$ ,  $\rho_\ell = 957.9 \text{ kg/m}^3$ ,  $\rho_v = 0.5955 \text{ kg/m}^3$ ,  $h_{fg} = 2257 \text{ kJ/kg}$ ,  $\sigma = 58.9 \times 10^{-3} \text{ N/m}$ .

**ANALYSIS:** The Lienhard-Eichhorn correlation for forced convection with cross flow over a cylinder is appropriate for estimating  $q''_{max}$ . Assuming high-velocity region flow, Eq. 10.13 with Eq. 10.14 can be written as

$$q''_{max} = \frac{\rho_v h_{fg} V}{\pi} \left[ \frac{1}{169} \left( \frac{\rho_\ell}{\rho_v} \right)^{3/4} + \frac{1}{19.2} \left( \frac{\rho_\ell}{\rho_v} \right)^{1/2} \left( \frac{\sigma}{\rho_v V^2 D} \right)^{1/3} \right].$$

Substituting numerical values, find

$$q''_{max} = \frac{1}{\pi} 0.5955 \text{ kg/m}^3 \times 2257 \times 10^3 \text{ J/kg} \times 2 \text{ m/s} \left[ \frac{1}{169} \left( \frac{957.9}{0.5955} \right)^{3/4} + \frac{1}{19.2} \left( \frac{957.9}{0.5955} \right)^{1/2} \left( \frac{58.9 \times 10^{-3} \text{ N/m}}{0.5955 \text{ kg/m}^3 (2 \text{ m/s})^2 0.005 \text{ m}} \right)^{1/3} \right]$$

$$q''_{max} = 4.331 \text{ MW/m}^2.$$

The high-velocity region assumption is satisfied if

$$\frac{q''_{max}}{\rho_v h_{fg} V} \stackrel{?}{<} \frac{0.275}{\pi} \left( \frac{\rho_\ell}{\rho_v} \right)^{1/2} + 1$$

$$\frac{4.331 \times 10^6 \text{ W/m}^2}{0.5955 \text{ kg/m}^3 \times 2257 \times 10^3 \text{ J/kg} \times 2 \text{ m/s}} = 1.61 \stackrel{?}{<} \frac{0.275}{\pi} \left( \frac{957.9}{0.5955} \right)^{1/2} + 1 = 4.51.$$

The inequality is satisfied. Using the  $q''_{max}$  estimate, the maximum heating rate is

$$q'_{max} = q''_{max} \cdot \pi D = 4.331 \text{ MW/m}^2 \times \pi (0.005 \text{ m}) = 68.0 \text{ kW/m}. \quad <$$

**COMMENTS:** Note that the effect of the forced convection is to increase the critical heat flux by  $4.33/1.26 = 3.4$  over the pool boiling case.

### PROBLEM 10.41

**KNOWN:** Diameter and wall heat flux for vertical steel tube. Velocity and pressure of saturated liquid water entering at bottom end.

**FIND:** (a) Tube wall temperature and water quality at  $x = 15$  m. (b) Tube wall temperature at location where single-phase vapor flow exists at mean temperature  $T_{\text{sat}}$ . (c) Plot tube wall temperature for  $-5 \text{ m} \leq x \leq 30 \text{ m}$ .

**SCHEMATIC:**

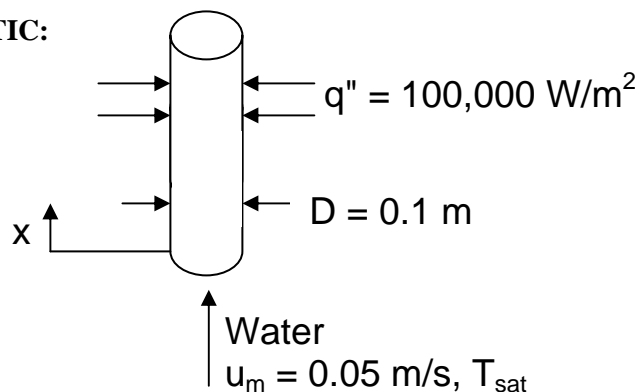

**ASSUMPTIONS:** (1) Steady-state conditions, (2) Constant properties. (3)  $G_{\text{sf}} = 1$ .

**PROPERTIES:** Table A.6, Saturated water, liquid (10 bars):  $T_{\text{sat}} = 452.8 \text{ K}$ ,  $\rho_{\ell} = 887.3 \text{ kg/m}^3$ ,  $h_{\text{fg}} = 2014 \text{ kJ/kg}$ ,  $\mu_{\ell} = 149.4 \times 10^{-6} \text{ N}\cdot\text{s/m}^2$ ,  $\nu_{\ell} = \mu_{\ell} / \rho_{\ell} = 1.684 \times 10^{-7} \text{ m}^2/\text{s}$ ,  $k_{\ell} = 0.6766 \text{ W/m}\cdot\text{K}$ ,  $\text{Pr}_{\ell} = 0.979$ . Table A.4, water vapor ( $T = 452.8 \text{ K}$ ):  $\rho_{\text{v}} = 5.094 \text{ kg/m}^3$ ,  $\mu_{\text{v}} = 14.95 \times 10^{-6} \text{ N}\cdot\text{s/m}^2$ ,  $k_{\text{v}} = 0.03353 \text{ W/m}\cdot\text{K}$ ,  $\text{Pr}_{\text{v}} = 1.149$ .

**ANALYSIS:** (a) The mass flow rate is

$$\dot{m} = \rho_{\ell} u_m A_c = 887.3 \text{ kg/m}^3 \times 0.05 \text{ m/s} \times \pi(0.1 \text{ m})^2 / 4 = 0.348 \text{ kg/s}$$

Then from Eq. 10.16,

$$\bar{X}(x = 15 \text{ m}) = \frac{q''_s \pi D x}{\dot{m} h_{\text{fg}}} = \frac{100,000 \text{ W/m}^2 \times \pi \times 0.1 \text{ m} \times 15 \text{ m}}{0.348 \text{ kg/s} \times 2.014 \times 10^6 \text{ J/kg}} = 0.672 \quad (1) \quad <$$

To find the wall temperature, we must first find the convection coefficient from Eq. 10.15. The Reynolds number is

$$\text{Re}_D = u_m D / \nu_{\ell} = 0.05 \text{ m/s} \times 0.1 \text{ m} / 1.684 \times 10^{-7} \text{ m}^2/\text{s} = 2.97 \times 10^4$$

Thus the flow is turbulent and the single phase convection coefficient can be calculated from Eq. 8.62,

$$\text{Nu}_D = \frac{(f/8) (\text{Re}_D - 1000) \text{Pr}_{\ell}}{1 + 12.7 (f/8)^{1/2} (\text{Pr}_{\ell}^{2/3} - 1)} = \frac{(0.0237/8) (2.97 \times 10^4 - 1000) 0.979}{1 + 12.7 (0.0237/8)^{1/2} (0.979^{2/3} - 1)} = 84.0$$

where from Equation 8.21,

$$f = (0.790 \ln \text{Re}_D - 1.64)^{-2} = (0.790 \ln (2.97 \times 10^4) - 1.64)^{-2} = 0.0237$$

Thus

$$h_{\text{sp}} = \text{Nu}_D k_{\ell} / D = 84.0 \times 0.6766 \text{ W/m}\cdot\text{K} / 0.1 \text{ m} = 568 \text{ W/m}^2 \cdot \text{K}$$

Continued...

### PROBLEM 10.41 (Cont.)

We must evaluate  $h$  from both Eqs. 10.15a and 10.15b and take the larger value. From Eq. 10.15b (which yields the larger value),

$$\begin{aligned} \frac{h}{h_{sp}} &= 1.136 \left( \frac{\rho_\ell}{\rho_v} \right)^{0.45} \bar{X}^{0.72} (1 - \bar{X})^{0.08} f(\text{Fr}) + 667.2 \left( \frac{q_s''}{\dot{m}'' h_{fg}} \right)^{0.7} (1 - \bar{X})^{0.8} G_{sf} \quad (2) \\ &= 1.136 \left( \frac{887.3}{5.094} \right)^{0.45} 0.672^{0.72} (1 - 0.672)^{0.08} \times 1 + 667.2 \left( \frac{10^5 \text{ W/m}^2}{44.4 \text{ kg/m}^2 \cdot \text{s} \times 2.014 \times 10^6 \text{ J/kg}} \right)^{0.7} (1 - 0.672)^{0.8} \times 1 \\ &= 10.3 \end{aligned}$$

where  $\dot{m}'' = \rho_\ell u_m = 44.4 \text{ kg/m}^2 \cdot \text{K}$ ,  $f(\text{Fr}) = 1$  for a vertical tube, and  $G_{sf} = 1$ . Thus  $h = 10.3(568 \text{ W/m}^2 \cdot \text{K}) = 5860 \text{ W/m}^2 \cdot \text{K}$  and from Eq. 10.3,

$$T_s = T_{\text{sat}} + q''/h = 452.8 \text{ K} + 10^5 \text{ W/m}^2 / 5860 \text{ W/m}^2 \cdot \text{K} = 470 \text{ K} = 197^\circ\text{C} \quad (3) \quad \leftarrow$$

(b) The mass flow rate is unchanged, but the viscosity is now that of the vapor, therefore,

$$\text{Re}_D = 4\dot{m} / \pi D \mu_v = 4 \times 0.348 \text{ kg/s} / \pi \times 0.1 \text{ m} \times 14.95 \times 10^{-6} \text{ N} \cdot \text{s/m}^2 = 2.97 \times 10^5$$

And once again from Eqs. 8.62 and 8.21,

$$\text{Nu}_D = \frac{(f/8)(\text{Re}_D - 1000) \text{Pr}_v}{1 + 12.7(f/8)^{1/2}(\text{Pr}_v^{2/3} - 1)} = \frac{(0.0145/8)(2.97 \times 10^5 - 1000) 1.149}{1 + 12.7(0.0145/8)^{1/2}(1.149^{2/3} - 1)} = 584$$

where

$$f = (0.790 \ln \text{Re}_D - 1.64)^{-2} = (0.790 \ln(2.97 \times 10^5) - 1.64)^{-2} = 0.0145$$

Thus

$$h = \text{Nu}_D k_v / D = 584 \times 0.03353 \text{ W/m} \cdot \text{K} / 0.1 \text{ m} = 196 \text{ W/m}^2 \cdot \text{K}$$

and

$$T_s = T_{\text{sat}} + q''/h = 452.8 \text{ K} + 10^5 \text{ W/m}^2 / 196 \text{ W/m}^2 \cdot \text{K} = 964 \text{ K} = 691^\circ\text{C} \quad \leftarrow$$

(c) For  $x < 0$ , the liquid is at its saturation temperature and the heat transfer coefficient is the single-phase value calculated in part (a). Thus the surface temperature is  $T_s = T_{\text{sat}} + q''/h_{sp} = 356^\circ\text{C}$ . For  $x > 0$  (until the fluid becomes fully vapor) Eqs. (1), (2), and (3) were entered into the *IHT* workspace along with the property values, previously calculated values of  $\dot{m}$ ,  $\dot{m}''$ , and  $h_{sp}$ , and other inputs. For locations where pure single-phase vapor exists,  $T_s = 691^\circ\text{C}$  as calculated in part (b). The results are shown below.

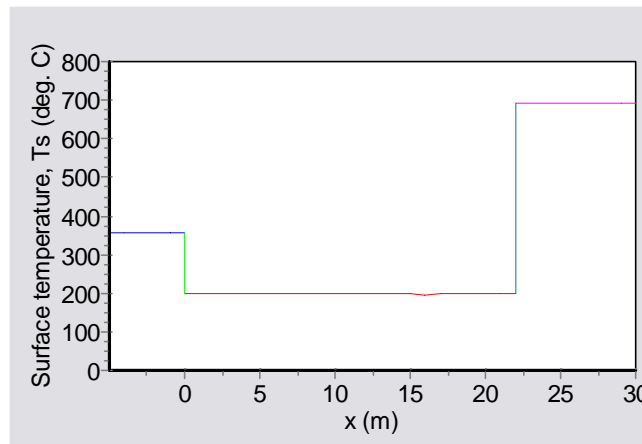

Continued....

### PROBLEM 10.41 (Cont.)

**COMMENTS:** (1) During pool boiling, we are concerned about approaching the critical heat flux. During forced convection boiling, an analogous situation exists whereby, once the liquid phase is entirely consumed, surface temperatures rise very rapidly, potentially melting the tube material. In applications where production of superheated steam is desired, such as in a Rankine power cycle, precautions must be made to ensure the tube material will survive the high temperatures in regions associated with pure vapor conditions. (2) Surface temperatures at negative  $x$  values will be slightly less than shown for the pure liquid flow. This is because the fluid quality is averaged across the tube radius and, for  $x < 0$ , fluid near the centerline of the tube will consist of subcooled liquid while superheated vapor exists near the tube wall. This situation can yield values of  $\bar{X}$  equal to zero, even though two-phase flow exists in the fluid, increasing the convection coefficient. Similarly, the average quality reaches a value of unity at  $x = 22.3$  m. Just beyond this location, the flow consists mainly of vapor, but a subcooled liquid mist can exist near the core of the flow, suppressing tube surface temperatures relative to those indicated just beyond  $x = 22.3$  m. (3) The quality reaches a value of 0.8 at  $x = 17.8$  m and Equation 10.15 is no longer applicable. The surface temperatures reported in the range  $17.8 \text{ m} \leq x \leq 22.3 \text{ m}$  will be less accurate than for those further upstream. (4) The pressure will decrease with increasing  $x$  due to friction losses. Prediction of pressure drops in flow boiling is difficult.

## PROBLEM 10.42

**KNOWN:** Diameter and wall thickness of horizontal tube. Saturation temperature and flow rate of R-134a. Wall heat flux.

**FIND:** Maximum wall temperature at  $x = 0.4$  m for (a) copper tube, (b) stainless steel tube.

**SCHEMATIC:**

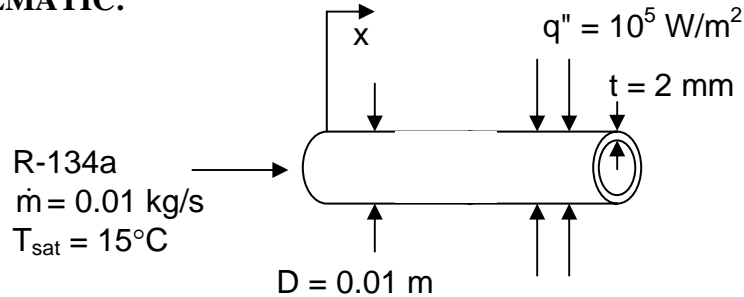

**ASSUMPTIONS:** (1) Constant properties, (2) Steady-state conditions, (3) The heat flux value of  $10^5 \text{ W/m}^2$  is based on the inner wall surface area.

**PROPERTIES:** *Table A.5*, Saturated liquid R-134a: ( $T_{\text{sat}} = 288 \text{ K}$ ):  $k_\ell = 0.0855 \text{ W/m}\cdot\text{K}$ ,  $c_{p,\ell} = 1387 \text{ J/kg}\cdot\text{K}$ ,  $\mu_\ell = 2.213 \times 10^{-4} \text{ N}\cdot\text{s/m}^2$ ,  $\text{Pr}_\ell = 3.54$ ,  $\rho_\ell = 1243.8 \text{ kg/m}^3$ ,  $h_{\text{fg}} = 186.6 \text{ kJ/kg}$ . Saturated vapor R-134a (given):  $\rho_v = 23.75 \text{ kg/m}^3$ . *Table A.1*, Pure copper ( $T \approx 300 \text{ K}$ ):  $k_w = 401 \text{ W/m}\cdot\text{K}$ . *Table A.1*, AISI 316 SS ( $T \approx 300 \text{ K}$ ):  $k_w = 13.4 \text{ W/m}\cdot\text{K}$ .

**ANALYSIS:** (a) From Eq. 10.16,

$$\bar{X}(x = 0.4 \text{ m}) = \frac{q''_s \pi D x}{\dot{m} h_{\text{fg}}} = \frac{10^5 \text{ W/m}^2 \times \pi \times 0.01 \text{ m} \times 0.4 \text{ m}}{0.01 \text{ kg/s} \times 186.6 \times 10^3 \text{ J/kg}} = 0.673$$

To find the wall temperature, we must first find the convection coefficient from Eq. 10.15. The Reynolds number is

$$\text{Re}_D = 4\dot{m} / \pi D \mu_\ell = 4 \times 0.01 \text{ kg/s} / \pi \times 0.01 \text{ m} \times 2.213 \times 10^{-4} \text{ N}\cdot\text{s/m}^2 = 5753$$

Thus the flow is turbulent and the single phase convection coefficient can be calculated from Eq. 8.62,

$$\text{Nu}_D = \frac{(f/8) (\text{Re}_D - 1000) \text{Pr}_\ell}{1 + 12.7 (f/8)^{1/2} (\text{Pr}_\ell^{2/3} - 1)} = \frac{(0.0370/8) (5753 - 1000) 3.54}{1 + 12.7 (0.0370/8)^{1/2} (3.54^{2/3} - 1)} = 36.3$$

where from Equation 8.21,

$$f = (0.790 \ln \text{Re}_D - 1.64)^{-2} = (0.790 \ln (5753) - 1.64)^{-2} = 0.0370$$

Thus

$$h_{\text{sp}} = \text{Nu}_D k_\ell / D = 36.3 \times 0.0855 \text{ W/m}\cdot\text{K} / 0.01 \text{ m} = 311 \text{ W/m}^2 \cdot \text{K}$$

Continued...

### PROBLEM 10.42 (Cont.)

We must evaluate  $h$  from both Eqs. 10.15a and 10.15b and take the larger value. We first calculate  $\dot{m}'' = \dot{m} / A_c = 127 \text{ kg/m}^2 \cdot \text{s}$ ,  $Fr = (\dot{m}'' / \rho_\ell)^2 / gD = 0.1069$ ,  $f(Fr) = 2.63Fr^{0.3} = 1.34$ , and note that  $G_{sf} = 1.63$  from Table 10.2. Then, from Eq. 10.15a (which yields the larger value),

$$\begin{aligned} \frac{h}{h_{sp}} &= 0.6683 \left( \frac{\rho_\ell}{\rho_v} \right)^{0.1} \bar{X}^{0.16} (1 - \bar{X})^{0.64} f(Fr) + 1058 \left( \frac{q_s''}{\dot{m}'' h_{fg}} \right)^{0.7} (1 - \bar{X})^{0.8} G_{sf} \\ &= 0.6683 \left( \frac{1243.8}{23.75} \right)^{0.1} 0.673^{0.16} (1 - 0.673)^{0.64} \times 1.34 + 1058 \left( \frac{10^5 \text{ W/m}^2}{127 \text{ kg/m}^2 \cdot \text{s} \times 186.6 \times 10^3 \text{ J/kg}} \right)^{0.7} (1 - 0.673)^{0.8} \times 1.63 \\ &= 15.9 \end{aligned}$$

Thus  $h = 15.9(311 \text{ W/m}^2 \cdot \text{K}) = 4942 \text{ W/m}^2 \cdot \text{K}$  and from Eq. 10.3,

$$T_s = T_{sat} + q'' / h = 15^\circ\text{C} + 10^5 \text{ W/m}^2 / 4942 \text{ W/m}^2 \cdot \text{K} = 35.2^\circ\text{C}$$

This is the inner wall temperature. The maximum wall temperature is the outer wall temperature, given by

$$T_{s,o} = T_s + q'' r_i \ln(r_o / r_i) / k_w = 35.2^\circ\text{C} + 10^5 \text{ W/m}^2 \times 0.005 \text{ m} \ln(0.007 / 0.005) / 401 \text{ W/m} \cdot \text{K}$$

$$T_{s,o} = 35.6^\circ\text{C} \quad \leftarrow$$

(b) For stainless steel, the value of  $G_{sf}$  changes,  $G_{sf} = 1$ , and the wall thermal conductivity is lower. Repeating the calculations (with Eq. 10.15b now yielding the larger value of  $h$ ) we find  $h = 3776 \text{ W/m}^2 \cdot \text{K}$ ,  $T_s = 41.5^\circ\text{C}$ , and

$$T_{s,o} = 54.0^\circ\text{C} \quad \leftarrow$$

**COMMENTS:** (1) The confinement number is  $Co = 0.089$  which is less than  $1/2$ , therefore Eq. 10.15 may be used. (2) For vertical tubes, the corresponding maximum wall temperatures are  $T_{max} = 35.9^\circ\text{C}$  and  $58.1^\circ\text{C}$ , respectively.

### PROBLEM 10.43

**KNOWN:** Various fluids at atmospheric pressure boiling in a tube.

**FIND:** Tube diameter associated with a Confinement number of 0.5.

**SCHEMATIC:**

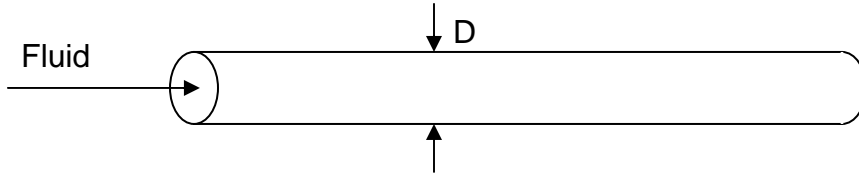

**ASSUMPTIONS:** (1) Constant properties.

**PROPERTIES:** *Table A.5*, Saturated ethanol ( $p = 1$  atm):  $\rho_\ell = 757$  kg/m<sup>3</sup>,  $\rho_v = 1.44$  kg/m<sup>3</sup>,  $\sigma = 17.7 \times 10^{-3}$  N/m. Saturated mercury ( $p = 1$  atm):  $\rho_\ell = 12,740$  kg/m<sup>3</sup>,  $\rho_v = 3.90$  kg/m<sup>3</sup>,  $\sigma = 417 \times 10^{-3}$  N/m. Saturated R-134a ( $p = 1$  atm):  $\rho_\ell = 1377$  kg/m<sup>3</sup>,  $\rho_v = 5.26$  kg/m<sup>3</sup>,  $\sigma = 15.4 \times 10^{-3}$  N/m. Saturated dielectric fluid, given in Problem 10.23 ( $p = 1$  atm):  $\rho_\ell = 1619.2$  kg/m<sup>3</sup>,  $\rho_v = 13.4$  kg/m<sup>3</sup>,  $\sigma = 8.1 \times 10^{-3}$  N/m. *Table A.6*, Saturated water ( $p = 1$  atm):  $\rho_\ell = 989$  kg/m<sup>3</sup>,  $\rho_v = 0.595$  kg/m<sup>3</sup>,  $\sigma = 58.9 \times 10^{-3}$  N/m.

**ANALYSIS:** The Confinement number is defined as,

$$Co = \sqrt{\sigma/[g(\rho_\ell - \rho_v)]} / D$$

Thus for a critical Confinement number of 0.5,

$$D = 2\sqrt{\sigma/[g(\rho_\ell - \rho_v)]}$$

The results are tabulated below for all five fluids.

Fluid	Critical diameter (mm)
Ethanol	3.03
Mercury	3.65
Water	4.93
R-134a	2.14
Dielectric fluid	1.43

**COMMENTS:** Despite the wide range of individual property values, the critical tube diameter below which the bubble occupies a significant fraction of the tube volume is confined to a relatively narrow range.

<



### PROBLEM 10.44

**KNOWN:** Saturated steam condensing on the outside of a brass tube and water flowing on the inside of the tube; convection coefficients are prescribed.

**FIND:** Steam condensation rate per unit length of the tube.

**SCHEMATIC:**

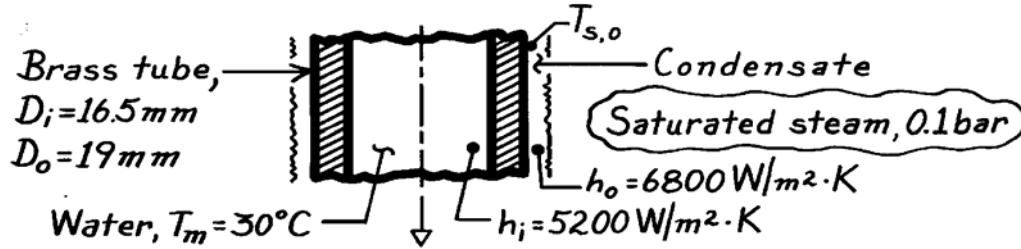

**ASSUMPTIONS:** (1) Steady-state conditions.

**PROPERTIES:** Table A-6, Water, vapor (0.1 bar):  $T_{\text{sat}} \approx 320\text{K}$ ,  $h_{\text{fg}} = 2390 \times 10^3 \text{ J/kg}$ ; Table A-1, Brass ( $\bar{T} = (T_m + T_{\text{sat}})/2 \approx 300\text{K}$ ):  $k = 110 \text{ W/m} \cdot \text{K}$

**ANALYSIS:** The condensation rate per unit length follows from Eq. 10.34 written as

$$\dot{m}' = q' / h'_{\text{fg}} \quad (1)$$

where the heat rate follows from Eq. 10.33 using an overall heat transfer coefficient

$$q' = U_o \cdot \pi D_o (T_{\text{sat}} - T_m) \quad (2)$$

and from Eq. 3.36,

$$U_o = \left[ \frac{1}{h_o} + \frac{D_o/2}{k} \ln \frac{D_o}{D_i} + \frac{D_o}{D_i} \frac{1}{h_i} \right]^{-1} \quad (3)$$

$$U_o = \left[ \frac{1}{6800 \text{ W/m}^2 \cdot \text{K}} + \frac{0.0095 \text{ m}}{110 \text{ W/m} \cdot \text{K}} \ln \frac{19}{16.5} + \frac{19}{16.5} \frac{1}{5200 \text{ W/m}^2 \cdot \text{K}} \right]^{-1}$$

$$U_o = \left[ 147.1 \times 10^{-6} + 12.18 \times 10^{-6} + 192.3 \times 10^{-6} \right]^{-1} \text{ W/m}^2 \cdot \text{K} = 2627 \text{ W/m}^2 \cdot \text{K}$$

Combining Eqs. (1) and (2) and substituting numerical values (see below for  $h'_{\text{fg}}$ ), find

$$\dot{m}' = U_o \pi D_o (T_{\text{sat}} - T_m) / h'_{\text{fg}}$$

$$\dot{m}' = 2627 \text{ W/m}^2 \cdot \text{K} \pi (0.019 \text{ m}) (320 - 303) \text{ K} / 2410 \times 10^3 \text{ J/kg} = 1.11 \times 10^{-3} \text{ kg/s. } <$$

**COMMENTS:** (1) Note from evaluation of Eq. (3) that the thermal resistance of the brass tube is not negligible. (2) From Eq. 10.27, with  $\text{Ja} = c_{p,\ell} (T_{\text{sat}} - T_s) / h_{\text{fg}}$ ,  $h'_{\text{fg}} = h_{\text{fg}} [1 + 0.68 \text{ Ja}]$ . Note from expression for  $U_o$ , that the internal resistance is the largest. Hence, estimate  $T_{s,o} \approx T_o - (R_o / \Sigma R) (T_o - T_m) \approx 313\text{K}$ . Hence,

$$h'_{\text{fg}} \approx 2390 \times 10^3 \text{ J/kg} \left[ 1 + 0.68 \times 4179 \text{ J/kg} \cdot \text{K} (320 - 313) \text{ K} / 2390 \times 10^3 \text{ J/kg} \right]$$

$$h'_{\text{fg}} = 2410 \text{ kJ/kg}$$

where  $c_{p,\ell}$  for water (liquid) is evaluated at  $T_f = (T_{s,o} + T_o) / 2 \approx 317\text{K}$ .

### PROBLEM 10.45

**KNOWN:** Insulated container having cold bottom surface and exposed to saturated vapor.

**FIND:** Expression for growth rate of liquid layer,  $\delta(t)$ ; thickness formed for prescribed conditions; compare with vertical plate condensate for same conditions.

**SCHEMATIC:**

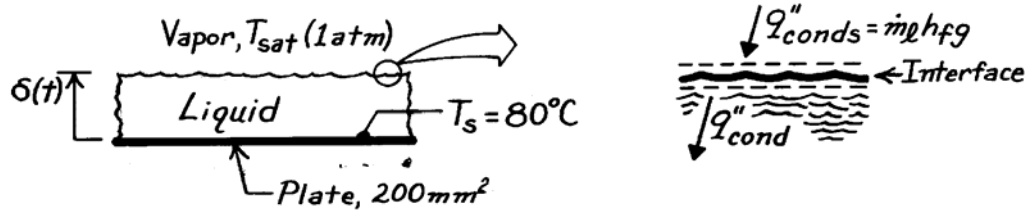

**ASSUMPTIONS:** (1) Side wall effects are negligible and, (2) Vapor-liquid interface is at  $T_{\text{sat}}$ , (3) Temperature distribution in liquid is linear, (4) Constant properties.

**PROPERTIES:** Table A-6, Saturated vapor ( $p = 1.0133 \text{ bar}$ ):  $T_{\text{sat}} = 100^\circ\text{C}$ ,  $\rho_v = 0.596 \text{ kg/m}^3$ ,  $h_{\text{fg}} = 2257 \text{ kJ/kg}$ ; Table A-6, Saturated liquid ( $T_f = 90^\circ\text{C} = 363\text{K}$ ):  $\rho_\ell = 965 \text{ kg/m}^3$ ,  $\mu_\ell = 313 \times 10^{-6} \text{ N}\cdot\text{s/m}^2$ ,  $k_\ell = 0.676 \text{ W/m}\cdot\text{K}$ ,  $c_{p,\ell} = 4207 \text{ J/kg}\cdot\text{K}$ ,  $\nu_\ell = \mu_\ell / \rho_\ell = 3.24 \times 10^{-7} \text{ m}^2/\text{s}$ .

**ANALYSIS:** Perform a surface energy balance on the interface (see above) recognizing that  $\dot{m}_\ell / A = \rho_\ell d\delta / dt$  from an overall mass rate balance on the liquid to obtain

$$\dot{E}_{\text{in}}'' - \dot{E}_{\text{out}}'' = q_{\text{conds}}'' - q_{\text{cond}}'' = \frac{\dot{m}}{A} h_{\text{fg}} - k_\ell \frac{T_{\text{sat}} - T_s}{\delta} = \rho_\ell \frac{d\delta}{dt} h_{\text{fg}} - k_\ell \frac{T_{\text{sat}} - T_s}{\delta} = 0 \quad (1)$$

where  $q_{\text{conds}}''$  is the condensation heat flux and  $q_{\text{cond}}''$  is the conduction heat flux into the liquid layer of thickness  $\delta$  with linear temperature distribution. Eq. (1) can be rewritten as

$$\rho_\ell h_{\text{fg}} \frac{d\delta}{dt} = k_\ell \frac{T_{\text{sat}} - T_s}{\delta}.$$

Separate variables and integrate with limits shown to obtain the liquid layer growth rate,

$$\int_0^\delta \delta d\delta = \int_0^t \frac{k_\ell (T_{\text{sat}} - T_s)}{\rho_\ell h_{\text{fg}}} dt \quad \text{or} \quad \delta = \left[ \frac{2k_\ell (T_{\text{sat}} - T_s)}{\rho_\ell h_{\text{fg}}} t \right]^{1/2}. \quad (2) \quad <$$

For the prescribed conditions, the liquid layer thickness and condensate formed in one hour are

$$\delta(1\text{h}) = \left[ 2 \times 0.676 \frac{\text{W}}{\text{m}\cdot\text{K}} (100 - 80)^\circ\text{C} \times 3600\text{s} / 965 \frac{\text{kg}}{\text{m}^3} \times 2257 \times 10^3 \frac{\text{J}}{\text{kg}} \right]^{1/2} = 6.69 \text{ mm} \quad <$$

$$M(1\text{h}) = \rho_\ell A \delta = 965 \text{ kg/m}^3 \times 200 \times 10^{-6} \text{ m}^2 \times 6.69 \times 10^{-3} \text{ m} = 1.29 \times 10^{-3} \text{ kg}. \quad <$$

Continued ...

**PROBLEM 10.45 (Cont.)**

The condensate formed on a vertical plate of length  $L = \sqrt{200 \text{ mm}^2} = 0.0141 \text{ m}$  with the same conditions follows from Eq. 10.34,

$$M_{vp} = \dot{m} \cdot t = \bar{h}_L A (T_{sat} - T_s) \cdot t / h'_{fg}$$

where  $h'_{fg}$  and  $\bar{h}_L$  follow from Eqs. 10.27 and one of Eqs. 10.43 - 10.45, respectively, with P given by Eq. 10.42.

$$h'_{fg} = h_{fg} (1 + 0.68 \text{Ja}) = h_{fg} \left( 1 + 0.68 c_{p,\ell} \Delta T / h_{fg} \right)$$

$$h'_{fg} = 2257 \times 10^3 \text{ J/kg} \left( 1 + 0.68 \times 4207 \frac{\text{J}}{\text{kg} \cdot \text{K}} (100 - 80)^\circ\text{C} / 2257 \times 10^3 \text{ J/kg} \right) = 2314 \text{ kJ/kg}$$

From Eq. 10.42,

$$P = \frac{k_\ell L (T_{sat} - T_s)}{\mu_\ell h'_{fg} (v_\ell^2 / g)^{1/3}}$$

$$= \frac{0.676 \text{ W/m} \cdot \text{K} \times 0.0141 \text{ m} (100 - 80)^\circ\text{C}}{313 \times 10^{-6} \text{ N} \cdot \text{s/m}^2 \times 2314 \times 10^3 \text{ J/kg} \times \left[ (3.24 \times 10^{-7} \text{ m}^2/\text{s})^2 / 9.8 \text{ m/s}^2 \right]^{1/3}} = 11.9$$

Since  $P < 15.8$ , Eq. 10.43 gives

$$\bar{h}_L = \frac{k_\ell}{(v_\ell^2 / g)^{1/3}} 0.943 P^{-1/4} = \frac{0.676 \text{ W/m} \cdot \text{K}}{\left[ (3.24 \times 10^{-7} \text{ m}^2/\text{s})^2 / 9.8 \text{ m/s}^2 \right]^{1/3}} 0.943 \times 11.9^{-1/4} = 15,560 \text{ W/m}^2 \cdot \text{K}$$

Hence,

$$M_{vp} = 15,560 \text{ W/m}^2 \cdot \text{K} \times 200 \times 10^{-6} \text{ m}^2 (100 - 80)^\circ\text{C} \times 3600 \text{ s} / 2314 \times 10^3 \text{ J/kg}$$

$$M_{vp} = 9.7 \times 10^{-2} \text{ kg.} \quad <$$

**COMMENTS:** Note that the condensate formed by the vertical plate is almost two orders of magnitude larger. For the vertical plate the rate of condensate formation is constant. For the container bottom surface, the rate decreases with increasing time since the conduction resistance increases as the liquid layer thickness increases.

### PROBLEM 10.46

**KNOWN:** Vertical tube experiencing condensation of steam on its outer surface.

**FIND:** Heat transfer and condensation rates.

**SCHEMATIC:**

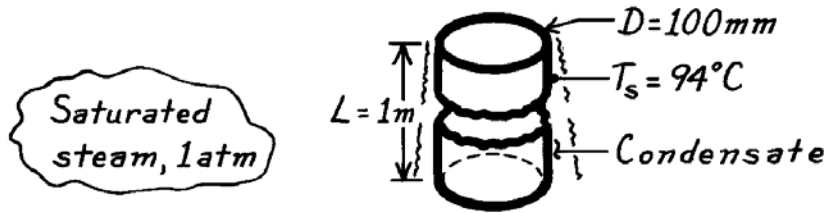

**ASSUMPTIONS:** (1) Film condensation, (2) Negligible non-condensibles, (3)  $D/2 \gg \delta$ , vertical plate behavior.

**PROPERTIES:** Table A-6, Water, vapor (1.0133 bar):  $T_{\text{sat}} = 100^\circ\text{C}$ ,  $\rho_v = 0.596 \text{ kg/m}^3$ ,  $h_{\text{fg}} = 2257 \text{ kJ/kg}$ ; Table A-6, Water, liquid ( $T_f = 97^\circ\text{C}$ ):  $\rho_\ell = 960.6 \text{ kg/m}^3$ ,  $\mu_\ell = 289 \times 10^{-6} \text{ N}\cdot\text{s/m}^2$ ,  $c_{p,\ell} = 4214 \text{ J/kg}\cdot\text{K}$ ,  $k_\ell = 0.679 \text{ W/m}\cdot\text{K}$ ,  $\nu_\ell = \mu_\ell / \rho_\ell = 3.01 \times 10^{-7} \text{ m}^2/\text{s}$ .

**ANALYSIS:** The heat transfer and condensation rates are

$$q = \bar{h}_L (\pi DL) (T_{\text{sat}} - T_s) \quad \dot{m} = q / h'_{\text{fg}}$$

where  $h'_{\text{fg}} = h_{\text{fg}} (1 + 0.68 \text{Ja})$  and  $\text{Ja} = c_{p,\ell} (T_{\text{sat}} - T_s) / h_{\text{fg}}$ . Hence  $\text{Ja} = 4214 \text{ J/kg}\cdot\text{K} (100 - 94)\text{K} / 2257 \times 10^3 \text{ J/kg} = 0.0112$  and  $h'_{\text{fg}} = 2274 \text{ kJ/kg}$ .

Eq. 10.42 yields,

$$P = \frac{k_\ell L (T_{\text{sat}} - T_s)}{\mu_\ell h'_{\text{fg}} (\nu_\ell^2 / g)^{1/3}} = \frac{0.679 \text{ W/m}\cdot\text{K} \times 1 \text{ m} \times (100 - 94)^\circ\text{C}}{289 \times 10^{-6} \text{ N}\cdot\text{s/m}^2 \times 2274 \times 10^3 \text{ J/kg} \times \left[ (3.01 \times 10^{-7} \text{ m}^2/\text{s})^2 / 9.8 \text{ m/s}^2 \right]^{1/3}} = 295$$

Since  $15.8 < P < 2530$ , Eq. 10.44 yields

$$\begin{aligned} \bar{h}_L &= \frac{k_\ell}{(\nu_\ell^2 / g)^{1/3}} \frac{1}{P} (0.68P + 0.89)^{0.82} \\ &= \frac{0.679 \text{ W/m}\cdot\text{K}}{\left[ (3.01 \times 10^{-7} \text{ m}^2/\text{s})^2 / 9.8 \text{ m/s}^2 \right]^{1/3}} \frac{1}{295} (0.68 \times 295 + 0.89)^{0.82} = 8500 \text{ W/m}^2 \cdot \text{K} \end{aligned}$$

Then from Eqs. 10.33 and 10.34,

$$\begin{aligned} q &= \bar{h}_L A (T_{\text{sat}} - T_s) = 8500 \text{ W/m}^2 \cdot \text{K} \times \pi \times 0.1 \text{ m} \times 1 \text{ m} \times (100 - 94)^\circ\text{C} = 16.0 \text{ kW} &< \\ \dot{m} &= q / h'_{\text{fg}} = (16.0 \times 10^3 \text{ W}) / (2.274 \times 10^6 \text{ J/kg}) = 7.1 \times 10^{-3} \text{ kg/s} &< \end{aligned}$$

**COMMENTS:** To determine whether the assumption  $D/2 \gg \delta$  is satisfied, use Eq. 10.26 to estimate  $\delta(L) \approx 0.12 \text{ mm}$ . Despite the laminar film assumption, clearly the assumption is justified and the vertical plate correlation is applicable.

### PROBLEM 10.47

**KNOWN:** Vertical tube experiencing condensation of steam on its outer surface.

**FIND:** Heat transfer and condensation rates.

**SCHEMATIC:**

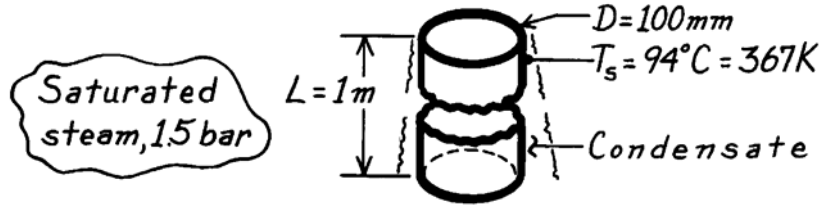

**ASSUMPTIONS:** (1) Film condensation, (2) Negligible condensibles in steam, (3)  $D/2 \gg \delta$ , vertical plate behavior.

**PROPERTIES:** Table A-6, Water, vapor (1.5 bar):  $T_{\text{sat}} \approx 385\text{ K}$ ,  $\rho_v = 0.876\text{ kg/m}^3$ ,  $h_{\text{fg}} = 2225\text{ kJ/kg}$ ;  
 Table A-6, Water, (liquid  $T_f = 376\text{ K}$ ):  $\rho_\ell = 956.2\text{ kg/m}^3$ ,  $c_{p,\ell} = 4220\text{ J/kg}\cdot\text{K}$ ,  $\mu_\ell = 271 \times 10^{-6}\text{ N}\cdot\text{s/m}^2$ ,  $k_\ell = 0.681\text{ W/m}\cdot\text{K}$ ,  $\nu_\ell = \mu_\ell / \rho_\ell = 2.83 \times 10^{-7}\text{ m}^2/\text{s}$ .

**ANALYSIS:** The heat transfer and condensation rates are

$$q = \bar{h}_L (\pi D L) (T_{\text{sat}} - T_s) \quad \dot{m} = q / h'_{\text{fg}}$$

where  $h'_{\text{fg}} = h_{\text{fg}} (1 + 0.68 \text{ Ja})$  and  $\text{Ja} = c_{p,\ell} (T_{\text{sat}} - T_s) / h_{\text{fg}}$ . Hence,  $\text{Ja} = 4220\text{ J/kg}\cdot\text{K} (385 - 367)\text{ K} / 2225 \times 10^3\text{ J/kg} = 0.0171$  and  $h'_{\text{fg}} = 2277\text{ kJ/kg}$ .

Eq. 10.42 yields,

$$P = \frac{k_\ell L (T_{\text{sat}} - T_s)}{\mu_\ell h'_{\text{fg}} (\nu_\ell^2 / g)^{1/3}} = \frac{0.681\text{ W/m}\cdot\text{K} \times 1\text{ m} \times (385 - 367)\text{ K}}{271 \times 10^{-6}\text{ N}\cdot\text{s/m}^2 \times 2277 \times 10^3\text{ J/kg} \times \left[ (2.83 \times 10^{-7}\text{ m}^2/\text{s})^2 / 9.8\text{ m/s}^2 \right]^{1/3}} = 986$$

Since  $15.8 < P < 2530$ , Eq. 10.44 yields

$$\begin{aligned} \bar{h}_L &= \frac{k_\ell}{(\nu_\ell^2 / g)^{1/3}} \frac{1}{P} (0.68P + 0.89)^{0.82} \\ &= \frac{0.681\text{ W/m}\cdot\text{K}}{\left[ (2.83 \times 10^{-7}\text{ m}^2/\text{s})^2 / 9.8\text{ m/s}^2 \right]^{1/3}} \frac{1}{986} (0.68 \times 986 + 0.89)^{0.82} = 7130\text{ W/m}^2 \cdot \text{K} \end{aligned}$$

$$\text{Hence, } q = 7130\text{ W/m}^2 \cdot \text{K} (\pi \times 0.1\text{ m} \times 1\text{ m}) (385 - 367)\text{ K} = 40.3\text{ kW} \quad <$$

$$\dot{m} = 40.3 \times 10^3\text{ W} / 2277 \times 10^3\text{ J/kg} = 0.0177\text{ kg/s.} \quad <$$

**COMMENTS:** By comparing these results with those of Problem 10.46, the effect of increased pressure on condensation can be seen.

p (bar)	$T_{\text{sat}}$ (K)	$T_{\text{sat}} - T_s$ (K)	$\bar{h}_L$ (W/m <sup>2</sup> ·K)	q (kW)	$\dot{m} \cdot 10^3$ (kg/s)
1.01	373	6	8500	16.0	7.1
1.5	385	18	7130	40.3	17.7

The effect of increasing the pressure from 1.01 to 1.5 bar is to increase the excess temperature three-fold, to decrease  $\bar{h}_L$  by 16%, and to increase the rates by a factor of 2.5.

## PROBLEM 10.48

**KNOWN:** Length of isothermal vertical plate,  $L$ , experiencing wave-free laminar condensation.

**FIND:** Expression for the average heat transfer coefficients for  $N$  plates each of length  $L_N = L/N$  to the average coefficient for the single plate.

**SCHEMATIC:**

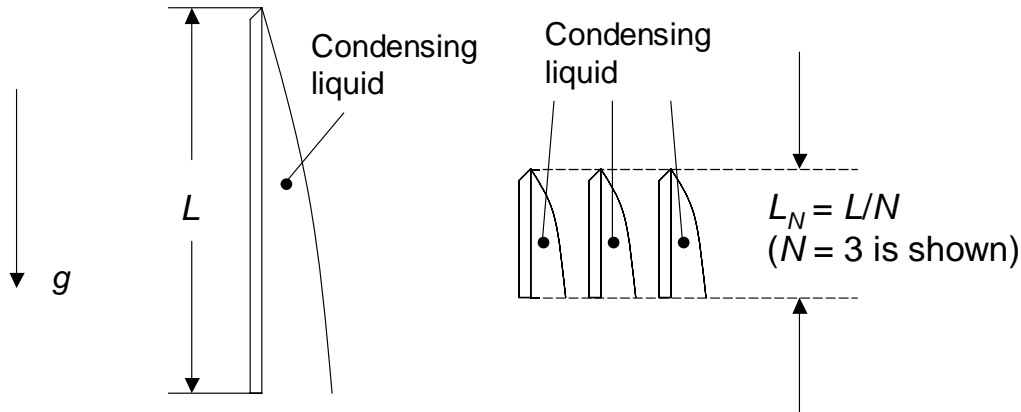

**ASSUMPTIONS:** (1) Constant properties.

**ANALYSIS:** Equation 10.42 gives

$$P = \frac{k_\ell L (T_{\text{sat}} - T_s)}{\mu_\ell h'_{fg} (v_\ell^2 / g)^{1/3}}$$

For wave free laminar condensation, Eq. 10.43 reveals that

$$\bar{h}_{L,1} \propto P^{-1/4} \propto L^{-1/4}$$

For multiple plates, each of length  $L_N = L/N$ ,

$$\bar{h}_{L,N} \propto L_N^{-1/4} \propto \left(\frac{L}{N}\right)^{-1/4}$$

Therefore,  $\bar{h}_{L,N} / \bar{h}_{L,1} = N^{1/4}$

<

**COMMENTS:** By breaking the single plate into shorter segments, the average liquid film thickness is reduced, resulting in a modest increase in the average heat transfer coefficient, resulting in heat transfer *enhancement*.

### PROBLEM 10.49

**KNOWN:** Cooled vertical plate 500-mm high and 200-mm wide condensing saturated steam at 1 atm.

**FIND:** (a) Surface temperature,  $T_s$ , required to achieve a condensation rate of  $\dot{m} = 25 \text{ kg/h}$ , (b) Compute and plot  $T_s$  as a function of the condensation rate for the range  $15 \leq \dot{m} \leq 50 \text{ kg/h}$ , and (c) Compute and plot  $T_s$  for the same range of  $\dot{m}$ , but if the plate is 200 mm high and 500 mm wide (vs. 500 mm high and 200 mm wide for parts (a) and (b)).

**SCHEMATIC:**

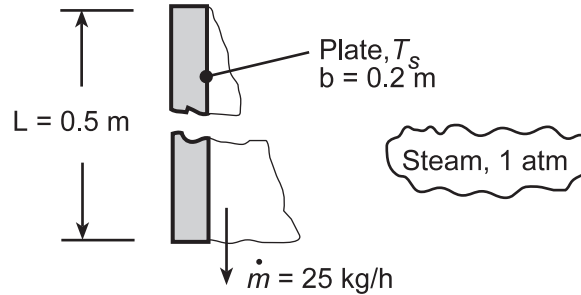

**ASSUMPTIONS:** (1) Film condensation, (2) Negligible non-condensables in steam.

**PROPERTIES:** Table A-6, Water, vapor (1.0133 bar):  $T_{\text{sat}} = 100^\circ\text{C}$ ,  $h_{\text{fg}} = 2257 \text{ kJ/kg}$ ; Table A-6, Water, liquid ( $T_f \approx (74 + 100)^\circ\text{C}/2 \approx 360 \text{ K}$ ):  $\rho_\ell = 967.1 \text{ kg/m}^3$ ,  $c_{p,\ell} = 4203 \text{ J/kg}\cdot\text{K}$ ,  $\mu_\ell = 324 \times 10^{-6} \text{ N}\cdot\text{s/m}^2$ ,  $k_\ell = 0.674 \text{ W/m}\cdot\text{K}$ ,  $\nu_\ell = \mu_\ell / \rho_\ell = 3.35 \times 10^{-7} \text{ m}^2/\text{s}$ .

**ANALYSIS:** (a) With knowledge of  $\dot{m} = 25 \text{ kg/h} = 6.94 \times 10^{-4} \text{ kg/s}$ ,  $\text{Re}_\delta$  can be calculated from Eq. 10.36,

$$\text{Re}_\delta = \frac{4\dot{m}}{\mu_\ell b} = \left(4 \times 6.94 \times 10^{-4} \text{ kg/s}\right) / \left(324 \times 10^{-6} \text{ N}\cdot\text{s/m}^2 \times 0.2 \text{ m}\right) = 429$$

Thus the flow is wavy laminar and Eq. 10.39 applies, from which

$$\begin{aligned} \bar{h}_L &= \frac{k_\ell}{(\nu_\ell^2/g)^{1/3}} \frac{\text{Re}_\delta}{1.08 \text{Re}_\delta^{1.22} - 5.2} \\ &= \frac{0.674 \text{ W/m}\cdot\text{K}}{\left[(3.35 \times 10^{-7} \text{ m}^2/\text{s})^2/9.8 \text{ m/s}^2\right]^{1/3}} \frac{429}{1.08 \times 429^{1.22} - 5.2} = 7320 \text{ W/m}^2 \cdot \text{K} \end{aligned}$$

Equation 10.34 can then be solved for  $T_{\text{sat}} - T_s$ , making use of Eq. 10.27, to give

$$T_{\text{sat}} - T_s = \frac{\dot{m} h_{\text{fg}}}{\bar{h}_L A - 0.68 \dot{m} c_{p,\ell}} = \frac{6.94 \times 10^{-4} \text{ kg/s} \times 2257 \times 10^3 \text{ J/kg}\cdot\text{K}}{7320 \text{ W/m}^2 \cdot \text{K} \times 0.1 \text{ m}^2 - 0.68 \times 6.94 \times 10^{-4} \text{ kg/s} \times 4203 \text{ J/kg}\cdot\text{K}} = 22.0^\circ\text{C}$$

Thus

$$T_s = 78^\circ\text{C} \quad \leftarrow$$

This value is to be compared to the assumed value of  $74^\circ\text{C}$  used for evaluating properties. See comment 1.

(b,c) Using the *IHT Correlations Tool, Film Condensation, Vertical Plate* for laminar, wavy-laminar and turbulent regions, combined with the *Properties Tool* for Water, the surface temperature  $T_s$  was calculated as a function of the condensation rate,  $\dot{m}$ , considering the two plate configurations as indicated in the plot below.

Continued...

## PROBLEM 10.49 (Cont.)

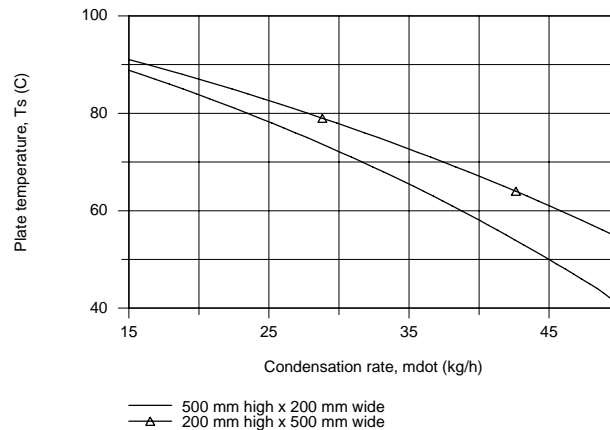

As expected the condensation rate increases with decreasing surface temperature. The plate with the shorter height ( $L = 200$  mm vs  $500$  mm) will have the thinner boundary layer and, hence, the higher average convection coefficient. Since both plate configurations have the same total surface area, the  $200$ -mm height plate will have the larger heat transfer and condensation rates. For the range of conditions examined, the condensate flow is in the wavy-laminar region.

**COMMENTS:** (1) With the IHT model developed for parts (b) and (c), the result for the part (a) conditions with  $\dot{m} = 25$  kg/h is  $T_s = 77.9^\circ\text{C}$  ( $Re_\delta = 438$  and  $\bar{h}_L = 7400$  W/m<sup>2</sup> · K). Hence, the assumed value ( $T_s = 74^\circ\text{C}$ ) required to initiate the analysis was a good one.

(2) A copy of the IHT Workspace model used to generate the above plot is shown below.

```

/* Correlations Tool
- Film Condensation, Vertical Plate, Laminar, wavy-laminar and turbulent regions: */
NuLbar = NuL_bar_FCO_VP(Re_delta,Pr) // Eq 10.38, 39, 40
NuLbar = hLbar * (nu^2 / g)^(1/3) / kl
g = 9.8 // Gravitational constant, m/s^2
Ts = Ts_C + 273 // Surface temperature, K
Ts_C = 78 // Initial guess value used to solve the model
Tsat = 100 + 273 // Saturation temperature, K
// The liquid properties are evaluated at the film temperature, Tf,
Tf = Tfluid_avg(Ts,Tsat)
// The condensation and heat rates are
q = hLbar * As * (Tsat - Ts) // Eq 10.33
As = L * b // Surface Area, m^2
mdot = q / h'fg // Eq 10.34
h'fg = hfg + 0.68 * cpl * (Tsat - Ts) // Eq 10.27
// The Reynolds number based upon film thickness is
Re_delta = 4 * mdot / (mu * b) // Eq 10.36
// Assigned Variables:
L = 0.5 // Vertical height, m
b = 0.2 // Width, m
mdot_h = mdot * 3600 // Condensation rate, kg/h
//mdot_h = 25 // Design value, part (a)
// Properties Tool - Water:
// Water property functions :T dependence, From Table A.6
// Units: T(K), p(bars);
xl = 0 // Quality (0=sat liquid or 1=sat vapor)
rho_l = rho_Tx("Water",Tf,xl) // Density, kg/m^3
hfg = hfg_T("Water",Tsat) // Heat of vaporization, J/kg
cpl = cp_Tx("Water",Tf,xl) // Specific heat, J/kg-K
mu_l = mu_Tx("Water",Tf,xl) // Viscosity, N-s/m^2
nu_l = nu_Tx("Water",Tf,xl) // Kinematic viscosity, m^2/s
kl = k_Tx("Water",Tf,xl) // Thermal conductivity, W/m-K
Pr_l = Pr_Tx("Water",Tf,xl) // Prandtl number

```



### PROBLEM 10.50

**KNOWN:** Plate dimensions, temperature and inclination. Pressure of saturated steam.

**FIND:** (a) Heat transfer and condensation rates for vertical plate, (b) Heat transfer and condensation rates for inclined plate.

**SCHEMATIC:**

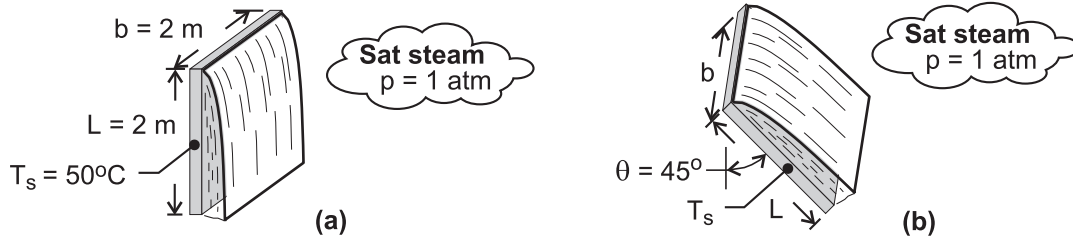

**ASSUMPTIONS:** (1) Constant properties.

**PROPERTIES:** Table A-6, saturated vapor ( $p=1.0133$  bars):  $T_{\text{sat}} = 100^\circ\text{C}$ ,  $h_{\text{fg}} = 2257$  kJ/kg. Table A-6, saturated liquid ( $T_f = 75^\circ\text{C}$ ):  $\rho_\ell = 975$  kg/m<sup>3</sup>,  $\mu_\ell = 375 \times 10^{-6}$  N·s/m<sup>2</sup>,  $k_\ell = 0.668$  W/m·K,  $c_{p,\ell} = 4193$  J/kg·K,  $\nu_\ell = \mu_\ell / \rho_\ell = 3.85 \times 10^{-7}$  m<sup>2</sup>/s,  $\text{Pr}_\ell = 2.35$ .

**ANALYSIS:** (a) Equation 10.27 gives  $h'_{\text{fg}} = h_{\text{fg}} + 0.68c_{p,\ell}(T_{\text{sat}} - T_s) = 2400$  kJ/kg. Then, from Eq. 10.42,

$$P = \frac{k_\ell L (T_{\text{sat}} - T_s)}{\mu_\ell h'_{\text{fg}} (\nu_\ell^2 / g)^{1/3}} = \frac{0.668 \text{ W/m} \cdot \text{K} \times 2 \text{ m} \times (100 - 50)^\circ\text{C}}{375 \times 10^{-6} \text{ N} \cdot \text{s/m}^2 \times 2400 \times 10^3 \text{ J/kg} \times \left[ (3.85 \times 10^{-7} \text{ m}^2/\text{s})^2 / 9.8 \text{ m/s}^2 \right]^{1/3}} = 3000$$

Therefore, Eq. 10.45 applies, and

$$\bar{h}_L = \frac{k_\ell}{(\nu_\ell^2 / g)^{1/3}} \frac{1}{P} \left[ (0.024P - 53) \text{Pr}_\ell^{1/2} + 89 \right]^{4/3} = \frac{0.668 \text{ W/m} \cdot \text{K}}{\left[ (3.85 \times 10^{-7} \text{ m}^2/\text{s})^2 / 9.8 \text{ m/s}^2 \right]^{1/3}} \frac{1}{3000} \left[ (0.024 \times 3000 - 53) \times 2.35^{1/2} + 89 \right]^{4/3} = 5220 \text{ W/m}^2 \cdot \text{K}$$

From Eqs. (10.33) and (10.34) the heat and condensation rates are then

$$q = \bar{h}_L A (T_{\text{sat}} - T_s) = 5220 \text{ W/m}^2 \cdot \text{K} \times 2 \text{ m} \times 2 \text{ m} \times (100 - 50)^\circ\text{C} = 1.04 \times 10^6 \text{ W} \quad <$$

$$\dot{m} = q/h'_{\text{fg}} = (1.04 \times 10^6 \text{ W}) / (2400 \times 10^3 \text{ J/kg}) = 0.435 \text{ kg/s} \quad <$$

(b) With  $\bar{h}_{L(\text{incl})} \approx (\cos \theta)^{1/4} \bar{h}_L$ , we obtain  $\bar{h}_{L(\text{incl})} \approx 0.917 \times 5220 \text{ W/m}^2 \cdot \text{K} = 4820 \text{ W/m}^2 \cdot \text{K}$ . If the inclination reduces  $\bar{h}_L$  by 8.4%, the heat and condensation rates are reduced by equivalent amounts. Hence,

$$q = 0.964 \times 10^6 \text{ W}, \quad \dot{m} = 0.402 \text{ kg/s} \quad <$$

### PROBLEM 10.51

**KNOWN:** Saturated ethylene glycol (1 atm) condensing on a vertical plate at 420 K.

**FIND:** Heat transfer rate to the plate and condensation rate.

**SCHEMATIC:**

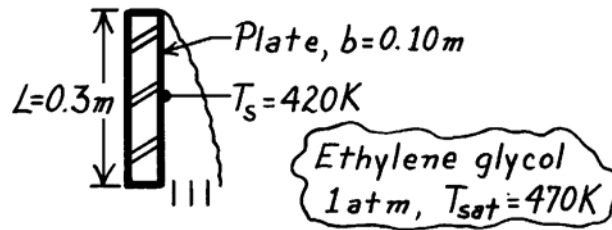

**ASSUMPTIONS:** (1) Film condensation, (2) Negligible non-condensable gases in vapor.

**PROPERTIES:** Table A-5, Ethylene glycol vapor (1 atm):  $T_{sat} = 470\text{ K}$ ,  $\rho_v \approx 0\text{ kg/m}^3$ ,  $h_{fg} = 812\text{ kJ/kg}$ ;  
Table A-5, Ethylene glycol, liquid ( $T_f = (T_s + T_{sat})/2 \approx 445\text{ K}$ ; use properties at upper limit of table 373K):  $\rho_\ell = 1058.5\text{ kg/m}^3$ ,  $c_{p,\ell} = 2742\text{ J/kg}\cdot\text{K}$ ,  $\mu_\ell = 0.215 \times 10^{-2}\text{ N}\cdot\text{s/m}^2$ ,  $k_\ell = 0.263\text{ W/m}\cdot\text{K}$ ,  $\nu_\ell = 2.03 \times 10^{-6}\text{ m}^2/\text{s}$ .

**ANALYSIS:** Equation 10.27 gives  $h'_{fg} = h_{fg} + 0.68c_{p,\ell}(T_{sat} - T_s) = 905\text{ kJ/kg}$ . Then Eq. 10.42 yields,

$$P = \frac{k_\ell L (T_{sat} - T_s)}{\mu_\ell h'_{fg} (\nu_\ell^2 / g)^{1/3}} = \frac{0.263\text{ W/m}\cdot\text{K} \times 0.3\text{ m} \times (470 - 420)\text{ K}}{0.215 \times 10^{-2}\text{ N}\cdot\text{s/m}^2 \times 905 \times 10^3\text{ J/kg} \times \left[ (2.03 \times 10^{-6}\text{ m}^2/\text{s})^2 / 9.8\text{ m/s}^2 \right]^{1/3}} = 27.1$$

Since  $15.8 < P < 2530$ , Eq. 10.44 yields

$$\begin{aligned} \bar{h}_L &= \frac{k_\ell}{(\nu_\ell^2 / g)^{1/3}} \frac{1}{P} (0.68P + 0.89)^{0.82} \\ &= \frac{0.263\text{ W/m}\cdot\text{K}}{\left[ (2.03 \times 10^{-6}\text{ m}^2/\text{s})^2 / 9.8\text{ m/s}^2 \right]^{1/3}} \frac{1}{27.1} (0.68 \times 27.1 + 0.89)^{0.82} = 1470\text{ W/m}^2\cdot\text{K} \end{aligned}$$

Then from Eqs. 10.33 and 10.34,

$$q = \bar{h}_L A (T_{sat} - T_s) = 1470\text{ W/m}^2\cdot\text{K} \times 0.3\text{ m} \times 0.1\text{ m} \times (470 - 420)\text{ K} = 2200\text{ W} \quad <$$

$$\dot{m} = q / h'_{fg} = (2200\text{ W}) / (905 \times 10^3\text{ J/kg}) = 2.43 \times 10^{-3}\text{ kg/s} \quad <$$

**COMMENTS:** Laminar condensation would yield results for the heat and mass rates within 1.2% of the wavy laminar values.

## PROBLEM 10.52

**KNOWN:** Vertical plate 2.5 m high at a surface temperature  $T_s = 54^\circ\text{C}$  exposed to steam at atmospheric pressure.

**FIND:** (a) Condensation and heat transfer rates per unit width, (b) Whether flow regime would stay the same or change if the height were halved, and (c) Compute and plot the condensation rates for the two plate heights (2.5 m and 1.25 m) as a function of surface temperature for the range,  $54 \leq T_s \leq 90^\circ\text{C}$ .

**SCHEMATIC:**

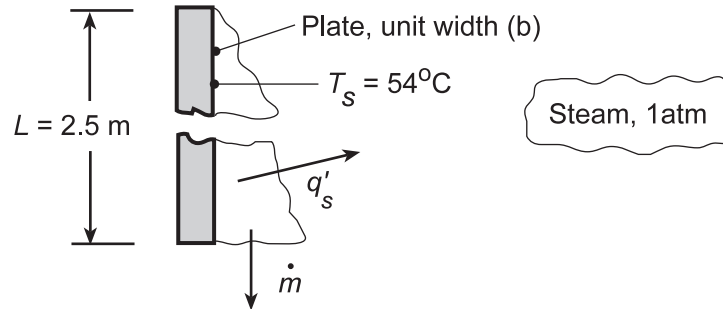

**ASSUMPTIONS:** (1) Film condensation, (2) Negligible non-condensables in steam.

**PROPERTIES:** Table A-6, Water, vapor (1 atm):  $T_{\text{sat}} = 100^\circ\text{C}$ ,  $h_{\text{fg}} = 2257 \text{ kJ/kg}$ ; Table A-6, Water, liquid ( $T_f = (100 + 54)^\circ\text{C}/2 = 350 \text{ K}$ ):  $\rho_\ell = 973.7 \text{ kg/m}^3$ ,  $k_\ell = 0.668 \text{ W/m}\cdot\text{K}$ ,  $\mu_\ell = 365 \times 10^{-6} \text{ N}\cdot\text{s/m}^2$ ,  $c_{p,\ell} = 4195 \text{ J/kg}\cdot\text{K}$ ,  $\text{Pr}_\ell = 2.29$ ,  $\nu_\ell = \mu_\ell / \rho_\ell = 3.75 \times 10^{-7} \text{ m}^2/\text{s}$ .

**ANALYSIS:** (a) From Equation 10.27,  $h'_{\text{fg}} = h_{\text{fg}} + 0.68c_{p,\ell}(T_{\text{sat}} - T_s) = 2388 \text{ kJ/kg}$ . Then Eq. 10.42 yields,

$$P = \frac{k_\ell L (T_{\text{sat}} - T_s)}{\mu_\ell h'_{\text{fg}} (\nu_\ell^2 / g)^{1/3}} = \frac{0.668 \text{ W/m}\cdot\text{K} \times 2.5 \text{ m} \times (100 - 54)^\circ\text{C}}{365 \times 10^{-6} \text{ N}\cdot\text{s/m}^2 \times 2388 \times 10^3 \text{ J/kg} \times [(3.75 \times 10^{-7} \text{ m}^2/\text{s})^2 / 9.8 \text{ m/s}^2]^{1/3}} = 3630$$

Since  $P > 2530$ , the regime is turbulent and Eq. 10.45 yields

$$\begin{aligned} \bar{h}_L &= \frac{k_\ell}{(\nu_\ell^2 / g)^{1/3}} \frac{1}{P} \left[ (0.024P - 53) \text{Pr}_\ell^{1/2} + 89 \right]^{4/3} \\ &= \frac{0.668 \text{ W/m}\cdot\text{K}}{[(3.75 \times 10^{-7} \text{ m}^2/\text{s})^2 / 9.8 \text{ m/s}^2]^{1/3}} \frac{1}{3630} \left[ (0.024 \times 3630 - 53) \times 2.29^{1/2} + 89 \right]^{4/3} = 5540 \text{ W/m}^2 \cdot \text{K} \end{aligned}$$

Then from Eqs. 10.33 and 10.34,

$$q' = \bar{h}_L L (T_{\text{sat}} - T_s) = 5540 \text{ W/m}^2 \cdot \text{K} \times 2.5 \text{ m} \times (100 - 54)^\circ\text{C} = 637 \text{ kW/m} \quad <$$

$$\dot{m}' = q' / h'_{\text{fg}} = 637 \times 10^3 \text{ W/m} / 2388 \times 10^3 \text{ J/kg} = 0.267 \text{ kg/m}\cdot\text{s} \quad <$$

(b) If the length is halved,  $L = 1.25 \text{ m}$ , then  $P$  will be halved,  $P = 1810$ .

Since  $15.8 < P < 2530$ , the flow regime changes to wavy laminar flow. <

Continued...

### PROBLEM 10.52 (Cont.)

Eq. 10.44 then yields  $\bar{h}_L = 5190 \text{ W/m}^2 \cdot \text{K}$  and we find  $q' = \bar{h}_L L (T_{\text{sat}} - T_s) = 299 \text{ kW/m}$  and  $\dot{m}' = q'/h'_{fg} = 0.125 \text{ kg/m} \cdot \text{s}$ . Note that the height was decreased by a factor of 2 while the rates decreased by a factor of 2.13. Would you have expected this result?

(c) Using the *IHT Correlation Tool, Film Condensation, Vertical Plate* for laminar, wavy-laminar, and turbulent regions, combined with the *Properties Tool for Water*, the condensation rates were calculated as a function of the surface temperature considering the two plate heights indicated.

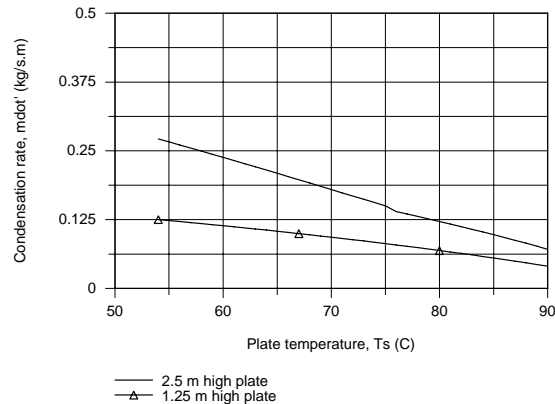

The condensation rate decreases nearly linearly with increasing surface temperature. The inflection in the upper curve ( $L = 2.5 \text{ m}$ ) corresponds to the flow transition at  $P = 2530$  between wavy-laminar and turbulent. For surface temperature lower than  $76^\circ\text{C}$ , the flow is turbulent over the  $2.5 \text{ m}$  plate. The flow over the  $1.25 \text{ m}$  plate is always in the wavy-laminar region. The fact that the  $2.5 \text{ m}$  plate experiences turbulent flow explains the height-rate relationship mentioned in the closing sentences of part (b).

**COMMENTS:** A copy of the IHT model used to generate the above plot is shown below.

```

/* Correlations Tool
- Film Condensation, Vertical Plate, Laminar, wavy-laminar and turbulent regions: */
NuLbar = NuL_bar_FCO_VP(Redelta,Pr) // Eq 10.38, 39, 40
NuLbar = hLbar * (nuL^2 / g)^(1/3) / kl
g = 9.8 // Gravitational constant, m/s^2
Ts = Ts_C + 273 // Surface temperature, K
Ts_C = 54 // Part (a) design condition
Tsat = 100 + 273 // Saturation temperature, K
// The liquid properties are evaluated at the film temperature, Tf
Tf = Tfluid_avg(Ts,Tsat)
// The condensation and heat rates are
q = hLbar * As * (Tsat - Ts) // Eq 10.33
As = L * b // Surface Area, m^2
mdot = q / h'fg // Eq 10.34
h'fg = hfg + 0.68 * cpl * (Tsat - Ts) // Eq 10.27
// The Reynolds number based upon film thickness is
Redelta = 4 * mdot / (muL * b) // Eq 10.36

// Assigned Variables:
L = 1.25 // Height, m
b = 1 // Width, m

// Properties Tool - Water:
// Water property functions :T dependence, From Table A.6
// Units: T(K), p(bars);
xl = 0 // Quality (0=sat liquid or 1=sat vapor)
rhoL = rho_Tx("Water",Tf,xl) // Density, kg/m^3
hfg = hfg_T("Water",Tsat) // Heat of vaporization, J/kg
cpl = cp_Tx("Water",Tf,xl) // Specific heat, J/kg-K
muL = mu_Tx("Water",Tf,xl) // Viscosity, N-s/m^2
nuL = nu_Tx("Water",Tf,xl) // Kinematic viscosity, m^2/s
kl = k_Tx("Water",Tf,xl) // Thermal conductivity, W/m-K
PrL = Pr_Tx("Water",Tf,xl) // Prandtl number

```

### PROBLEM 10.53

**KNOWN:** Two vertical plate configurations maintained at  $90^\circ\text{C}$  for condensing saturated steam at 1 atm: single plate  $L \times w$  and two plates each  $L/2 \times w$  where  $L$  and  $w$  are the vertical and horizontal dimensions, respectively.

**FIND:** Which case will provide the larger heat transfer or condensation rate.

**SCHEMATIC:**

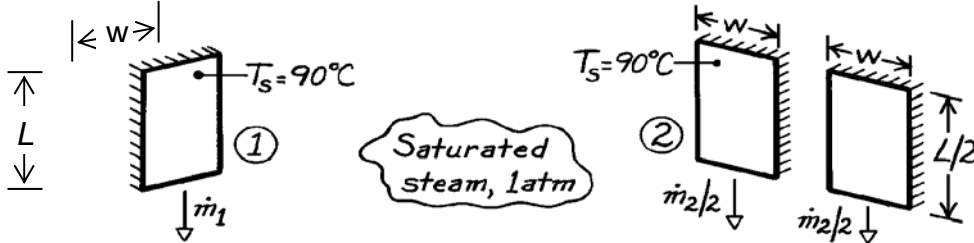

**ASSUMPTIONS:** (1) Negligible concentration of non-condensable gases in the steam.

**PROPERTIES:** Table A-6, Saturated water vapor (1 atm):  $T_{\text{sat}} = 100^\circ\text{C}$ ,  $h_{\text{fg}} = 2257 \text{ kJ/kg}$ ; Saturated water ( $T_f = (T_s + T_{\text{sat}})/2 = (90 + 100)^\circ\text{C}/2 = 95^\circ\text{C} = 368\text{K}$ ):  $\rho_\ell = (1/v_f) = 962 \text{ kg/m}^3$ ,  $\mu_\ell = 296 \times 10^{-6} \text{ N}\cdot\text{s/m}^2$ ,  $k_\ell = 0.678 \text{ W/m}\cdot\text{K}$ ,  $c_{p,\ell} = 4212 \text{ J/kg}\cdot\text{K}$ ,  $\nu_\ell = \mu_\ell / \rho_\ell = 3.08 \times 10^{-7} \text{ m}^2/\text{s}$ .

**ANALYSIS:** The heat transfer and condensation rates are

$$q = \bar{h}_L A_s (T_{\text{sat}} - T_s) \quad \dot{m} = q / h'_{\text{fg}}$$

where the total area,  $A_s$ , is the same for the two cases. Hence,

$$\frac{q_1}{q_2} = \frac{\dot{m}_1}{\dot{m}_2} = \frac{\bar{h}_{L,1}}{\bar{h}_{L,2}}$$

where the average convection coefficients  $\bar{h}_{L,1}$  and  $\bar{h}_{L,2}$  are evaluated for plate lengths of  $L$  and  $L/2$ , respectively. For *laminar film* condensation on both plates, using the correlation of Eq. 10.31, with  $\bar{h}_L \propto L^{-1/4}$ ,

$$q_1 / q_2 = (L / [L/2])^{-1/4} = 0.84.$$

Hence, case 2 is preferred and provides 19% more heat transfer ( $q_2 / q_1 = 1/0.84 = 1.19$ ). <

The laminar solution is valid provided that  $P < 15.8$ , therefore from Eq. 10.42 we require

Continued ...

### PROBLEM 10.53 (Cont.)

$$L < 15.8 \frac{\mu_\ell h'_{fg} (v_\ell^2/g)^{1/3}}{k_\ell (T_{\text{sat}} - T_s)} = 15.8 \times \frac{296 \times 10^{-6} \text{ N} \cdot \text{s}/\text{m}^2 \times 2286 \times 10^3 \text{ J}/\text{kg} \times \left[ (3.08 \times 10^{-7} \text{ m}^2/\text{s})^2 / 9.8 \text{ m}/\text{s}^2 \right]^{1/3}}{0.678 \text{ W}/\text{m} \cdot \text{K} \times (100 - 90)^\circ\text{C}}$$
$$= 0.035 \text{ m} = 35 \text{ mm}$$

where from Eq. 10.27,

$$h'_{fg} = h_{fg} + 0.68 c_{p,\ell} (T_{\text{sat}} - T_s)$$

$$h'_{fg} = 2257 \text{ kJ}/\text{kg} + 0.68 \times 4212 \text{ J}/\text{kg} \cdot \text{K} (100 - 90) \text{ K} = 2286 \text{ kJ}/\text{kg}.$$

We can anticipate for other, larger values of  $L$  that the comparison of  $\bar{h}_L$  values cannot be so easily made. However, according to Figure 10.13, we expect the same behavior of  $\bar{h}_L$  in the *wavy* region since  $\bar{h}_L$  decreases with increasing  $\text{Re}_\delta$  (corresponding to increasing  $L$ ), and anticipate that indeed case 2 will provide the greater condensation rate. Note that in the turbulent region with the increase in  $\bar{h}_L$  with  $\text{Re}_\delta$ , we cannot conclude with certainty which case is preferred.

**COMMENTS:** In dealing with single-phase, forced or free convection, we associate thin thermal boundary layers with higher heat transfer rates. For vertical plates, we would expect the shorter plate to have the higher convection heat transfer coefficient. The results of this problem suggest the same is true for condensation on the vertical plate.

## PROBLEM 10.54

**KNOWN:** Number, diameter and wall temperature of condenser tubes in a square array. Pressure of saturated steam around tubes.

**FIND:** Rates of heat transfer and condensation per unit length of the array.

**SCHEMATIC:**

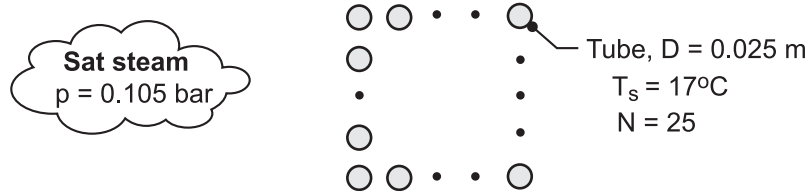

**ASSUMPTIONS:** (1) Spatially uniform cylinder temperature, (2) Negligible concentration of noncondensable gases in steam, (3) Average heat transfer coefficient varies with tube row as  $n = -1/6$  in Eq. 10.49.

**PROPERTIES:** Table A-6, saturated vapor ( $p_{\text{sat}} = 0.105 \text{ bar}$ ):  $T_{\text{sat}} = 320 \text{ K} = 47^\circ\text{C}$ ,  $\rho_v = 0.0713 \text{ kg/m}^3$ ,  $h_{\text{fg}} = 2390 \text{ kJ/kg}$ . Table A-6, saturated liquid ( $T_f = 32^\circ\text{C} = 305 \text{ K}$ ):  $\rho_\ell = 995 \text{ kg/m}^3$ ,  $\mu_\ell = 769 \times 10^{-6} \text{ N}\cdot\text{s/m}^2$ ,  $k_\ell = 0.620 \text{ W/m}\cdot\text{K}$ ,  $c_{p,\ell} = 4178 \text{ J/kg}\cdot\text{K}$ .

**ANALYSIS:** Equation 10.46 may be used to find the convection coefficient for the top, unfinned tube. With  $\text{Ja} = c_{p,\ell} (T_{\text{sat}} - T_s) / h_{\text{fg}} = 0.052$  and  $h'_{\text{fg}} = h_{\text{fg}} (1 + 0.68 \text{Ja}) = 1.04 (2.390 \times 10^6 \text{ J/kg}) = 2.51 \times 10^6 \text{ J/kg}$ ,

$$\bar{h}_D = 0.729 \left[ \frac{g \rho_\ell (\rho_\ell - \rho_v) k_\ell^3 h'_{\text{fg}}}{\mu_\ell (T_{\text{sat}} - T_s) D} \right]^{1/4}$$

$$\bar{h}_D = 0.729 \left[ \frac{9.8 \text{ m/s}^2 \times 995 \text{ kg/m}^3 (995 - 0.0713) \text{ kg/m}^3 (0.62 \text{ W/m}\cdot\text{K})^3 2.51 \times 10^6 \text{ J/kg}}{769 \times 10^{-6} \text{ N}\cdot\text{s/m}^2 (30^\circ\text{C}) 0.025 \text{ m}} \right]^{1/4} = 7308 \text{ W/m}^2 \cdot \text{K}$$

From Eq. 10.49 the array-averaged convection coefficient is

$$\bar{h}_{D,N} = \bar{h}_D N^n = 7308 \text{ W/m}^2 \cdot \text{K} \times 25^{-1/6} = 4274 \text{ W/m}^2 \cdot \text{K}.$$

The heat rate per unit length of the array is

$$q' = N^2 \bar{h}_{D,N} (\pi D) (T_{\text{sat}} - T_s) = 625 \times 4274 \text{ W/m}^2 \cdot \text{K} (\pi \times 0.025 \text{ m}) 30^\circ\text{C} = 6.29 \times 10^6 \text{ W/m} \quad <$$

The corresponding condensation rate is

$$\dot{m}' = \frac{q'}{h'_{\text{fg}}} = \frac{6.29 \times 10^6 \text{ W/m}}{2.51 \times 10^6 \text{ J/kg}} = 2.51 \text{ kg/s}\cdot\text{m} \quad <$$

**COMMENTS:** The heat transfer rate could be increased by adding fins to the tubes.

## PROBLEM 10.55

**KNOWN:** Tube wall diameters and thermal conductivity. Mean temperature and flow rate of water flow through tube. Pressure of saturated steam around tube.

**FIND:** (a) Rates of heat transfer and condensation per unit length, (b) Effect of flow rate on heat transfer.

**SCHEMATIC:**

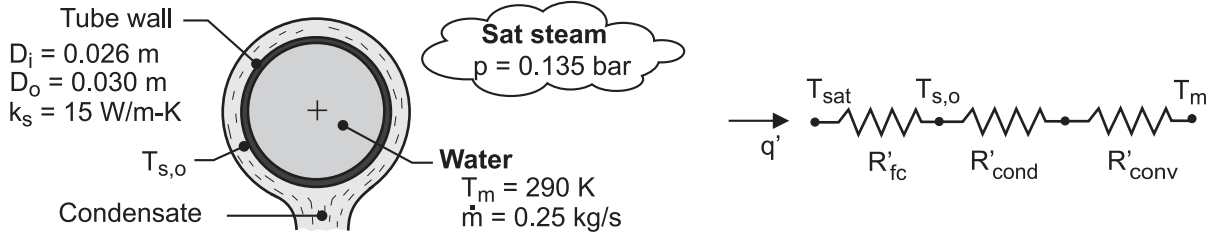

**ASSUMPTIONS:** (1) Negligible concentration of noncondensable gases in the steam, (2) Uniform tube surface temperatures, (3) Laminar film condensation, (4) Fully-developed internal flow, (5) Constant properties.

**PROPERTIES:** Table A-6, water ( $T_m = 290$  K):  $\mu = 0.00108$  N·s/m<sup>2</sup>,  $k = 0.598$  W/m·K,  $Pr = 7.56$ .

Table A-6, saturated vapor ( $p = 0.135$  bar):  $T_{sat} = 325$  K = 52°C,  $\rho_v = 0.0904$  kg/m<sup>3</sup>,  $h_{fg} = 2378$

kJ/kg. Table A-6, saturated liquid ( $T_f \approx T_{sat}$ ):  $\rho_\ell = 987$  kg/m<sup>3</sup>,  $c_{p,\ell} = 4182$  J/kg·K,

$\mu_\ell = 528 \times 10^{-6}$  N·s/m<sup>2</sup>,  $k_\ell = 0.645$  W/m·K.

**ANALYSIS:** (a) From the thermal circuit, the heat rate may be expressed as

$$q' = \frac{T_{sat} - T_m}{R'_{fc} + R'_{cond} + R'_{conv}} \quad (1)$$

where,  $R'_{cond} = \ln(D_o / D_i) / 2\pi k_s = 0.00152$  m·K/W

The convection resistance is  $R'_{conv} = (\pi D_i h_i)^{-1}$ . With  $Re_D = 4\dot{m} / \pi D_i \mu = 11,336$ , the flow is turbulent and the Dittus-Boelter correlation yields

$$h_i = \left( \frac{k}{D_i} \right) 0.023 Re_D^{4/5} Pr^{0.4} = \left( \frac{0.598 \text{ W/m}\cdot\text{K}}{0.026 \text{ m}} \right) 0.023 (11,336)^{4/5} (7.56)^{0.4} = 2082 \text{ W/m}^2 \cdot \text{K}$$

The convection resistance is then

$$R'_{conv} = (\pi D_i h_i)^{-1} = \left( \pi \times 0.026 \text{ m} \times 2082 \text{ W/m}^2 \cdot \text{K} \right)^{-1} = 0.00588 \text{ m}\cdot\text{K/W}$$

The resistance associated with the condensate film is  $R'_{fc} = (\pi D_o \bar{h}_o)^{-1}$ , where  $\bar{h}_o$  is given by Eq. 10.46. With  $C = 0.729$ ,

$$\bar{h}_o = C \left[ \frac{g \rho_\ell (\rho_\ell - \rho_v) k_\ell^3 h'_{fg}}{\mu_\ell (T_{sat} - T_{s,o}) D_o} \right]^{1/4} = 0.729 \left[ \frac{9.8 \text{ m/s}^2 \times 987 (987 - 0.09) \text{ kg}^2/\text{m}^6 (0.645 \text{ W/m}\cdot\text{K})^3 h'_{fg}}{528 \times 10^{-6} \text{ N}\cdot\text{s/m}^2 (325 - T_{s,o}) \times 0.030 \text{ m}} \right]^{1/4}$$

$$\bar{h}_o = 462 \left( \frac{\text{W}^3 \cdot \text{kg}}{\text{m}^8 \cdot \text{K}^3 \cdot \text{s}} \right)^{1/4} \left( \frac{h'_{fg}}{325 - T_{s,o}} \right)^{1/4}$$

where  $h'_{fg} = h_{fg} + 0.68 c_{p,\ell} (T_{sat} - T_{s,o}) = 2.38 \times 10^6$  J/kg + 2844 J/kg·K (325 -  $T_{s,o}$ )

The unknown surface temperature may be determined from an additional rate equation, such as

Continued ...



**PROBLEM 10.55 (Cont.)**

$$q' = \frac{T_{s,o} - T_m}{R'_{\text{cond}} + R'_{\text{conv}}} \quad (2)$$

Substituting the thermal resistances into Eqs. (1) and (2), an iterative solution yields

$$T_{s,o} = 321.6 \text{ K} = 48.6^\circ\text{C} \quad q' = 4270 \text{ W/m} \quad <$$

The condensation rate is then

$$\dot{m}'_{\text{cond}} = \frac{q'}{h'_{\text{fg}}} = \frac{4270 \text{ W/m}}{2.39 \times 10^6 \text{ J/kg}} = 0.00179 \text{ kg/s} \cdot \text{m} \quad <$$

The corresponding values of the condensate convection coefficient and resistance are

$$\bar{h}_o = 13,380 \text{ W/m}^2 \cdot \text{K}$$

and  $R'_{\text{fc}} = 0.000793 \text{ m} \cdot \text{K/W}$

Because  $R'_{\text{conv}}$  is much larger than  $R'_{\text{cond}}$  and  $R'_{\text{fc}}$ , attention should be paid to reducing the convection resistance in order to increase the heat rate. The resistance to heat flow by convection is the *limiting factor*.

(b) The effects of varying the flow rate are shown below

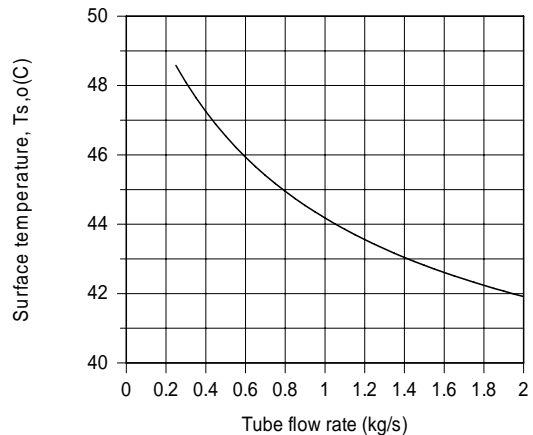
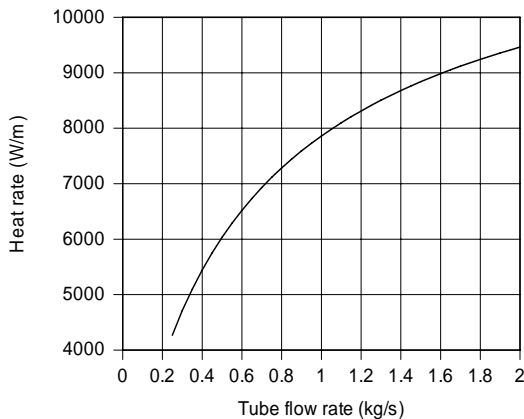

The effect of increasing  $\dot{m}$  on  $q'$  is significant and is accompanied by a reduction in  $T_{s,o}$ .

**COMMENTS:** (1) Use of the IHT convection and condensation correlations, as well as its temperature-dependent properties of water facilitated the numerical solution. (2) Evaluation of the film properties at  $T_{\text{sat}}$  is reasonable for part (a), since  $T_f = (T_{s,o} + T_{\text{sat}})/2 = 50.3^\circ\text{C} \approx T_{\text{sat}}$ . However, with increasing  $\dot{m}$  and hence decreasing  $T_{s,o}$ , the approximation would become inappropriate.

### PROBLEM 10.56

**KNOWN:** Inner surface of a vertical thin-walled container of length  $L$  and diameter  $D$  experiences condensation of a saturated vapor. Container wall maintained at a uniform surface temperature by flowing cold water across its outer surface.

**FIND:** Expression for the time,  $t_f$ , required to fill the container with condensate assuming the condensate film is laminar. Express your result in terms of  $D$ ,  $L$ ,  $(T_{sat} - T_s)$ ,  $g$ , and appropriate fluid properties.

**SCHEMATIC:**

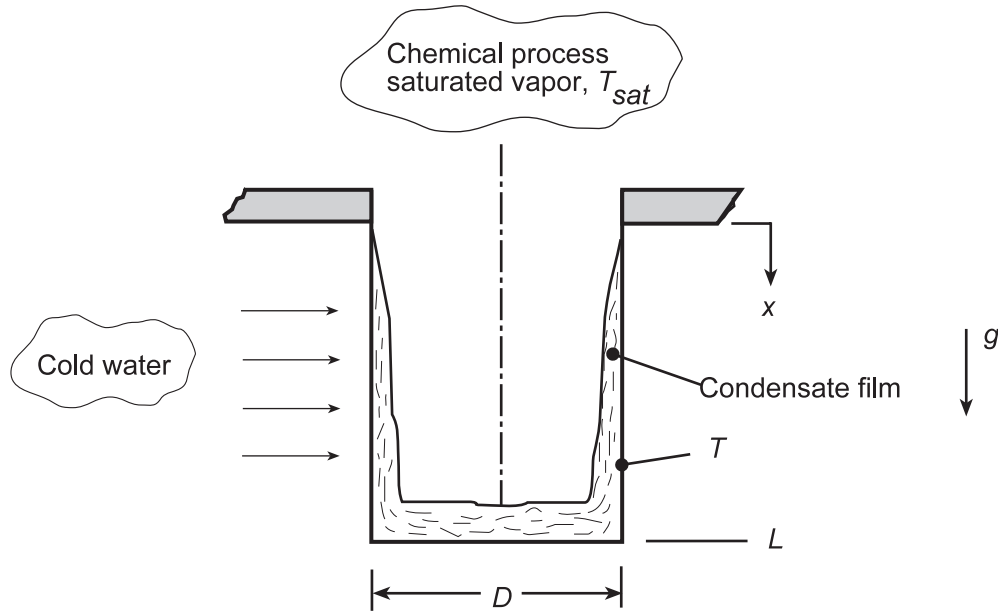

**ASSUMPTIONS:** (1) Laminar film condensation on a vertical surface, (2) Uniform temperature container wall surface, and (3) Mass of liquid condensate in the laminar film negligible compared to liquid mass on bottom of container.

**ANALYSIS:** From an instantaneous mass balance on the container,

$$\dot{m}(t) = \frac{dM}{dt} \quad (1)$$

Where  $\dot{m}(t)$  is the condensate rate and the liquid mass in the container,  $M$ , is

$$M = \rho_\ell \left( \pi D^2 / 4 \right) (L - x) \quad (2)$$

The condensate rate from Eq. 10.34 can be expressed as

$$\dot{m}(t) = \frac{q}{h'_{fg}} = \frac{\bar{h}_s A_s (T_{sat} - T_s)}{h'_{fg}} \quad (3)$$

where the average film coefficient over the height 0 to  $x$  from Eq. 10.31 is,

$$\bar{h}_s = 0.943 \left[ \frac{g \rho_\ell (\rho_\ell - \rho_v) k_\ell^3 h'_{fg}}{\mu_\ell (T_{sat} - T_s) x} \right]^{1/4} \quad (4)$$

and the surface area over which condensation occurs is

$$A_s = \pi D x \quad (5)$$

Continued...

**PROBLEM 10.56 (Cont.)**

Substituting Eqs (2-5) into Eq. (1),

$$0.943 \left[ \frac{g \rho_\ell (\rho_\ell - \rho_v) k_\ell^3 h'_{fg}}{\mu_\ell (T_{sat} - T_s) L} \right]^{1/4} \frac{L^{1/4}}{x^{1/4}} (\pi D x) (T_{sat} - T_s) / h'_{fg} = -\rho_\ell \left( \pi D^2 / 4 \right) \frac{dx}{dt} \quad (6)$$

Separate variables and identify the limits of integration,

$$\left\{ 0.943 \left[ \frac{g \rho_\ell (\rho_\ell - \rho_v) k_\ell^3 h'_{fg}}{\mu_\ell (T_{sat} - T_s) L} \right]^{1/4} L^{1/4} (\pi D) (T_{sat} - T_s) / \left[ h'_{fg} \rho_\ell \left( \pi D^2 / 4 \right) \right] \right\} \int_0^{t_f} dt = - \int_{x=L}^0 x^{-3/4} dx \quad (7)$$

The RHS integrates to

$$- \left[ x^{1/4} / (1/4) \right]_L^0 = 4L^{1/4} \quad (8)$$

and solving for  $t_f$ ,

$$t_f = 4 \left[ \frac{\rho_\ell \left( \pi D^2 / 4 \right) L h'_{fg}}{0.943 \left[ \frac{g \rho_\ell (\rho_\ell - \rho_v) k_\ell^3 h'_{fg}}{\mu_\ell (T_{sat} - T_s) L} \right]^{1/4} (\pi D L) (T_{sat} - T_s)} \right] <$$

**COMMENTS:** The numerator and denominator in the bracketed expression are of special significance. The numerator is the product of the mass in the filled container and the latent heat of vaporization; that is, the total energy removed by the cold water. What is the physical significance of the denominator? Can you interpret the time-to-fill,  $t_f$ , expression in light of these terms?

## PROBLEM 10.57

Determine the total condensation rate and heat transfer rate for the process of Problem 10.46 when the pipe is oriented at angles of  $\theta = 0, 30, 45$  and  $60^\circ$  from the horizontal.

**KNOWN:** Dimensions and surface temperature of tube exposed to steam. Non-vertical orientation angles.

**FIND:** Heat transfer and condensation rates.

**SCHEMATIC:**

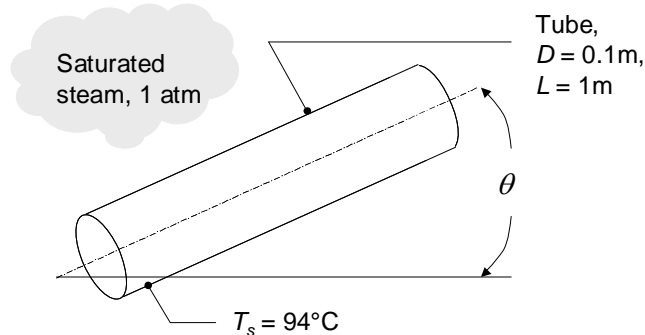

**ASSUMPTIONS:** (1) Laminar film condensation, (2) Negligible end effects, (3) Negligible concentration of non-condensable gases in steam.

**PROPERTIES:** Table A-6, Water Vapor (1 atm):  $T_{\text{sat}} = 100^\circ\text{C}$ ,  $\rho_v = 0.596\text{ kg/m}^3$ ,  $h_{fg} = 2257\text{ kJ/kg}$ ; Table A-6, Liquid Water ( $T_f = (T_s + T_{\text{sat}})/2 = 370\text{K}$ ):  $\rho_l = 960.6\text{ kg/m}^3$ ,  $c_{p,l} = 4214\text{ J/kg}\cdot\text{K}$ ,  $\mu_l = 289 \times 10^{-6}\text{ N}\cdot\text{s/m}^2$ ,  $k_l = 0.679\text{ W/m}\cdot\text{K}$ .

**ANALYSIS:** The tube's length to diameter ratio,  $L/D = 10$ , must exceed  $B = 1.8 \tan \theta$  in order to use Equation 10.46. The value of  $B$  is 0, 1.039, 1.8, and 3.118 for  $\theta = 0, 30, 45$  and  $60^\circ$ , respectively. Therefore, Equation 10.46 may be used by replacing  $g$  with  $g \cos \theta$  where the modified latent heat is found from Equation 10.27

$$\begin{aligned} h'_{fg} &= h_{fg} (1 + 0.68Ja) = h_{fg} + 0.68c_{p,l} (T_{\text{sat}} - T_s) \\ &= 2257\text{ kJ/kg} + 0.68 \times 4.214\text{ kJ/kg}\cdot\text{K} (100 - 94)^\circ\text{C} = 2274\text{ kJ/kg} \end{aligned}$$

Hence,

$$\begin{aligned} \bar{h}_D &= 0.729 \left[ \frac{g \cos \theta \rho_l (\rho_l - \rho_v) k_l^3 h'_{fg}}{\mu_l (T_{\text{sat}} - T_s) D} \right]^{1/4} \\ &= 0.729 \left[ \frac{9.81\text{ m/s}^2 \times \cos \theta \times 960.6\text{ kg/m}^3 (960.6 - 0.596)\text{ kg/m}^3 \times (0.679\text{ W/m}\cdot\text{K})^3 \times 2274 \times 10^3\text{ J/kg}\cdot\text{K}}{289 \times 10^{-6}\text{ N}\cdot\text{s/m}^2 (100 - 94)^\circ\text{C} \times 0.1\text{ m}} \right]^{1/4} \\ &= 10,120\text{ W/m}^2 \cdot \text{K} (\cos \theta)^{1/4} \end{aligned}$$

and the values of  $\bar{h}_D$  are 10,120, 9760, 9280 and 8510  $\text{W/m}^2 \cdot \text{K}$  for  $\theta = 0, 30, 45$  and  $60^\circ$ , respectively.

For  $\theta = 0^\circ$ , the heat transfer rate is

$$q = \bar{h}_D (\pi DL) (T_{\text{sat}} - T_s) = 10,120\text{ W/m}^2 \cdot \text{K} (\pi \times 0.1\text{ m} \times 1\text{ m}) (100 - 94)^\circ\text{C} = 19,076\text{ W} \quad <$$

$$\text{and the condensation rate is } \dot{m} = q / h'_{fg} = 19076\text{ W} / 2274 \times 10^3\text{ J/kg} = 8.39 \times 10^{-3}\text{ kg/s} \quad <$$

Similarly,  $q = 18,400, 17,500$  and  $16,000\text{ W}$  and  $\dot{m} = 8.09 \times 10^{-3}, 7.69 \times 10^{-3}$  and  $7.05 \times 10^{-3}\text{ kg/s}$ , for  $\theta = 30, 45$  and  $60^\circ$ , respectively. <

**COMMENTS:** The condensation rates decrease with increasing  $\theta$ . Why?

### PROBLEM 10.58

**KNOWN:** Horizontal tube, 50mm diameter, with surface temperature of 34°C is exposed to steam at 0.2 bar.

**FIND:** Estimate the heat transfer and condensation rates per unit length of the tube.

**SCHEMATIC:**

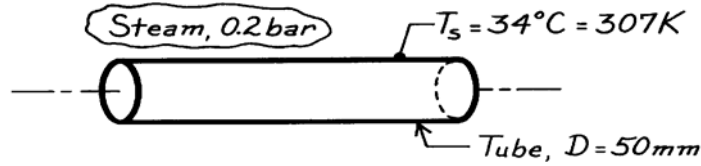

**ASSUMPTIONS:** (1) Laminar film condensation, (2) Negligible non-condensibles in steam.

**PROPERTIES:** Table A-6, Saturated steam (0.2 bar):  $T_{\text{sat}} = 333\text{K}$ ,  $\rho_v = 0.129\text{ kg/m}^3$ ,  $h_{\text{fg}} = 2358\text{ kJ/kg}$ ; Table A-6, Water, liquid ( $T_f = (T_s + T_{\text{sat}})/2 = 320\text{K}$ ):  $\rho_\ell = 989.1\text{ kg/m}^3$ ,  $c_{p,\ell} = 4180\text{ J/kg}\cdot\text{K}$ ,  $\mu_\ell = 577 \times 10^{-6}\text{ N}\cdot\text{s/m}^2$ ,  $k_\ell = 0.640\text{ W/m}\cdot\text{K}$ .

**ANALYSIS:** From Eqs. 10.33 and 10.34, the heat transfer and condensate rates per unit length of the tube are

$$q' = \bar{h}_D (\pi D) (T_{\text{sat}} - T_s) \quad \dot{m}' = q' / h'_{\text{fg}}$$

where from Eq. 10.27 with  $\text{Ja} = c_{p,\ell} (T_{\text{sat}} - T_s) / h_{\text{fg}}$ ,

$$h'_{\text{fg}} = h_{\text{fg}} [1 + 0.68 \text{Ja}] = 2358 \frac{\text{kJ}}{\text{kg}} \left[ 1 + 0.68 \times 4180 \text{ J/kg}\cdot\text{K} (333 - 307) \text{ K} / 2358 \times 10^3 \text{ J/kg} \right]$$

$$h'_{\text{fg}} = 2432 \text{ kJ/kg.}$$

For laminar film condensation, Eq. 10.45 is appropriate for estimating  $\bar{h}_D$  with  $C = 0.729$ ,

$$\bar{h}_D = 0.729 \left[ \frac{g \rho_\ell (\rho_\ell - \rho_v) k_\ell^3 h'_{\text{fg}}}{\mu_\ell (T_{\text{sat}} - T_s) D} \right]^{1/4}$$

$$\bar{h}_D = 0.729 \left[ \frac{9.8 \text{ m/s}^2 \times 989.1 \text{ kg/m}^3 (989.1 - 0.129) \text{ kg/m}^3 (0.640 \text{ W/m}\cdot\text{K})^3 \times 2432 \times 10^3 \text{ J/kg}}{577 \times 10^{-6} \text{ N}\cdot\text{s/m}^2 (333 - 307) \text{ K} \times 0.050 \text{ m}} \right]^{1/4}$$

$$\bar{h}_D = 6926 \text{ W/m}^2 \cdot \text{K.}$$

Hence, the heat transfer and condensation rates are

$$q' = 6926 \text{ W/m}^2 \cdot \text{K} (\pi \times 0.050 \text{ m}) (333 - 307) \text{ K} = 28.3 \text{ kW/m} \quad <$$

$$\dot{m}' = 28.3 \times 10^3 \text{ W/m} / 2432 \times 10^3 \text{ J/kg} = 1.16 \times 10^{-2} \text{ kg/s}\cdot\text{m.} \quad <$$

## PROBLEM 10.59

**KNOWN:** Dimensions and surface temperature of grooved horizontal tube exposed to steam at 0.2 bar.

**FIND:** Minimum condensation and heat transfer rates per unit length of the tube.

**SCHEMATIC:**

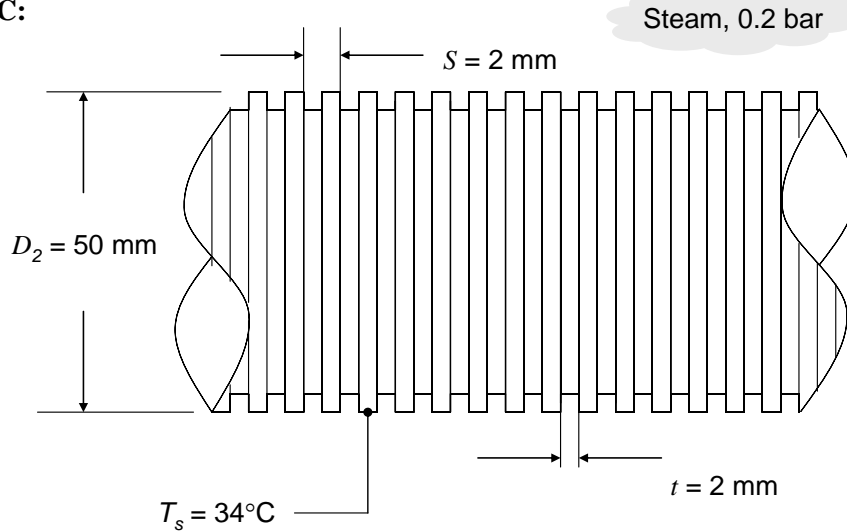

**ASSUMPTIONS:** (1) Laminar film condensation, (2) Negligible non-condensable gas in steam.

**PROPERTIES:** Table A-6, Saturated steam (0.2 bar):  $T_{\text{sat}} = 333 \text{ K}$ ,  $\rho_v = 0.129 \text{ kg/m}^3$ ,  $h_{fg} = 2358 \text{ kJ/kg}$ ,  $\sigma = 66.1 \times 10^{-3} \text{ N/m}$ ; Table A-6, Water, liquid ( $T_f = (T_s + T_{\text{sat}})/2 = 320 \text{ K}$ ):  $\rho_\ell = 989.1 \text{ kg/m}^3$ ,  $c_{p,\ell} = 4180 \text{ J/kg}\cdot\text{K}$ ,  $\mu_\ell = 577 \times 10^{-6} \text{ N}\cdot\text{s/m}^2$ ,  $k_\ell = 0.640 \text{ W/m}\cdot\text{K}$ .

**ANALYSIS:** The heat transfer rate of Problem 10.58 is based upon an unmilled tube of diameter  $D_2 = 50 \text{ mm}$ . From Eqs. 10.33 and 10.34, the heat transfer and condensation rates per unit length for this tube are

$$q'_2 = \bar{h}_D (\pi D_2) (T_{\text{sat}} - T_s) \quad \dot{m}' = q' / h'_{fg} \quad (1a,b)$$

where from Eq. 10.27 with  $Ja = c_{p,\ell} (T_{\text{sat}} - T_s) / h_{fg}$ ,

$$h'_{fg} = h_{fg} [1 + 0.68 Ja] = 2358 \text{ kJ/kg} [1 + 0.68 \times 4180 \text{ J/kg}\cdot\text{K} (333 - 307) \text{ K} / 2358 \times 10^3 \text{ J/kg}]$$

$$h'_{fg} = 2432 \text{ kJ/kg.}$$

For laminar film condensation, Eq. 10.46 is appropriate for estimating  $\bar{h}_D$  with  $C = 0.729$ ,

$$\bar{h}_D = C \frac{k_\ell}{D_2} \left[ \frac{\rho_l g (\rho_l - \rho_v) h'_{fg} D_2^3}{\mu_\ell k_\ell (T_{\text{sat}} - T_s)} \right]^{1/4} \quad (2)$$

Continued...

**PROBLEM 10.59 (Cont.)**

$$\begin{aligned}\bar{h}_D &= 0.729 \frac{0.640 \text{ W/m} \cdot \text{K}}{0.05 \text{ m}} \left[ \frac{989.1 \text{ kg/m}^3 \times 9.8 \text{ m/s}^2 (989.1 - 0.129) \text{ kg/m}^3 \times 2432 \times 10^3 \text{ J/kg} \times (0.05 \text{ m})^3}{577 \times 10^{-6} \text{ N} \cdot \text{s/m}^2 \times 0.640 \text{ W/m} \cdot \text{K} \times (333 - 307) \text{ K}} \right]^{1/4} \\ &= 6926 \text{ W/m}^2 \cdot \text{K}.\end{aligned}$$

Hence, the heat transfer and condensation rates for the smooth large tube are

$$\begin{aligned}q'_2 &= 6926 \text{ W/m}^2 \cdot \text{K} (\pi \times 0.05 \text{ m}) (333 - 307) \text{ K} = 28.3 \text{ kW/m} \\ \dot{m}'_{\text{cond},2} &= q'_2 / h'_{fg} = 28.3 \text{ kW/m} / 2432 \text{ kJ/kg} = 0.0116 \text{ kg/s} \cdot \text{m}\end{aligned}$$

The portions of the larger tube that are not milled away serve as fins. Therefore, the heat transfer rate from the grooved large tube is related to the heat transfer rate from a corresponding smooth tube of smaller diameter  $D_1 = 46 \text{ mm}$ , modified by the enhancement ratio, Eq. 10.48. We must first determine the heat transfer rate  $q'_{\text{uft},1}$  from a smooth tube of diameter  $D_1$ . From Eqs. (2) and (1a) above, with  $D_2$  replaced by  $D_1$ , and the same value for  $h'_{fg}$  :

$$q'_{\text{uft},1} = 26.6 \text{ kW/m}$$

The enhancement factor is given by Eq. 10.48.

$$\begin{aligned}\varepsilon_{\text{ft},\text{min}} &= \frac{q_{\text{ft},\text{min}}}{q_{\text{uft}}} = \frac{tr_2}{Sr_1} \left[ \frac{r_1}{r_2} + 1.02 \frac{\sigma r_1}{(\rho_l - \rho_v) g t^3} \right]^{1/4} \\ &= \frac{2 \text{ mm} \times 25 \text{ mm}}{4 \text{ mm} \times 23 \text{ mm}} \left[ \frac{23 \text{ mm}}{25 \text{ mm}} + 1.02 \frac{66.1 \times 10^{-3} \text{ N/m} \times 0.023 \text{ m}}{(989.1 - 0.129) 9.8 \text{ m/s}^2 (0.002 \text{ m})^3} \right]^{1/4} \\ &= 1.16\end{aligned}$$

Thus the minimum heat transfer rate for the grooved tube is

$$q'_{\text{ft},\text{min},1} = \varepsilon_{\text{ft},\text{min}} q'_{\text{uft},1} = 1.16 \times 26.6 \text{ kW/m} = 30.9 \text{ kW/m} \quad <$$

The corresponding condensation rate is

$$\dot{m}' = 30.9 \times 10^3 \text{ W/m} / 2432 \times 10^3 \text{ J/kg} = 1.27 \times 10^{-2} \text{ kg/s} \cdot \text{m} \quad <$$

The enhancement due to milling the larger diameter tube, for either heat transfer or condensation rate, is therefore

$$\text{Enhancement ratio} = q'_{\text{ft},\text{min},1} / q'_2 = 30.9 \text{ kW/m} / 28.3 \text{ kW/m} = 1.09 \quad <$$

**COMMENTS:** For a given fluid and operating conditions would an optimum groove geometry exist?

### PROBLEM 10.60

**KNOWN:** Horizontal tube 1m long with surface temperature of 70°C used to condense steam at 1 bar.

**FIND:** Diameter required for condensation rate of 125 kg/h.

**SCHEMATIC:**

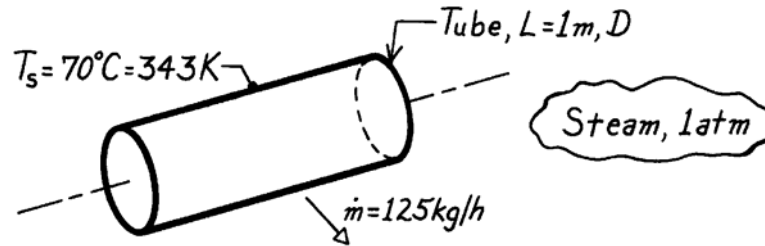

**ASSUMPTIONS:** (1) Laminar film condensation, (2) Negligible non-condensibles in steam.

**PROPERTIES:** Table A-6, Water, vapor (1 atm):  $T_{\text{sat}} = 100^\circ\text{C}$ ,  $\rho_v = 0.596 \text{ kg/m}^3$ ,  $h_{\text{fg}} = 2257 \text{ kJ/kg}$ ; Table A-6, Water, liquid ( $T_f = (T_s + T_{\text{sat}})/2 = 358\text{K}$ ):  $\rho_\ell = 968.6 \text{ kg/m}^3$ ,  $c_{p,\ell} = 4201 \text{ J/kg}\cdot\text{K}$ ,  $\mu_\ell = 332 \times 10^{-6} \text{ N}\cdot\text{s/m}^2$ ,  $k_\ell = 0.673 \text{ W/m}\cdot\text{K}$ .

**ANALYSIS:** From the rate equation, Eq. 10.34, with  $A = \pi D L$ , the required diameter is

$$D = \dot{m} h'_{\text{fg}} / \pi L \bar{h}_D (T_{\text{sat}} - T_s) \quad (1)$$

where from Eq. 10.27 with  $\text{Ja} = c_{p,\ell} (T_{\text{sat}} - T_s) / h_{\text{fg}}$ ,

$$h'_{\text{fg}} = h_{\text{fg}} (1 + 0.68 \text{Ja}) = 2257 \frac{\text{kJ}}{\text{kg}} \left( 1 + 0.68 \frac{4201 \text{ J/kg}\cdot\text{K} \times (100 - 70) \text{K}}{2257 \times 10^3 \text{ J/kg}} \right) = 2343 \text{ kJ/kg}. \quad (2)$$

Substituting numerical values, Eq. (1) becomes

$$D = \frac{125 \text{ kg}}{3600 \text{ s}} \times 2343 \times 10^3 \frac{\text{J}}{\text{kg}} / \pi \times 1 \text{m} \times \bar{h}_D (100 - 70) \text{K} = 863.2 \bar{h}_D^{-1}. \quad (3)$$

The appropriate correlation for  $\bar{h}_D$  is Eq. 10.46 with  $C = 0.729$ ,

$$\bar{h}_D = 0.729 \left[ \frac{g \rho_\ell (\rho_\ell - \rho_v) k_\ell^3 h'_{\text{fg}}}{\mu_\ell (T_{\text{sat}} - T_s) D} \right]^{1/4}. \quad (4)$$

Substitute Eq. (4) for  $\bar{h}_D$  into Eq. (3) and use numerical values,

$$863.2 D^{-1} = 0.729 \times$$

$$\left[ \frac{9.8 \text{ m/s}^2 \times 968.6 \text{ kg/m}^3 (968.6 - 0.596) \text{ kg/m}^3 (0.673 \text{ W/m}\cdot\text{K})^3 \times 2343 \times 10^3 \text{ J/kg}}{332 \times 10^{-6} \text{ N}\cdot\text{s/m}^2 (100 - 70) \text{K} \times D} \right]^{1/4}$$

$$863.2 D^{-1} = 3693.4 D^{-1/4}$$

$$D = 0.144 \text{m} = 144 \text{mm}. \quad <$$

**COMMENTS:** Note for this situation  $\text{Ja} = 0.06$ .



## PROBLEM 10.61

**KNOWN:** Array of condenser tubes exposed to saturated steam at 0.1 bar.

**FIND:** (a) Condensation rate per unit length of square array, (b) Options for increasing the condensation rate.

**SCHEMATIC:**

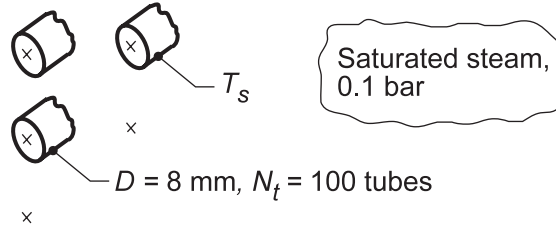

**ASSUMPTIONS:** (1) Spatially uniform cylinder temperature. (2) Average heat transfer coefficient varies with tube row with  $n = -1/6$  in Eq. 10.49. (3) Negligible concentration of noncondensable gases in the steam.

**PROPERTIES:** Table A.6, Saturated water vapor (0.1 bar):  $T_{\text{sat}} \approx 319 \text{ K}$ ,  $\rho_v = 0.067 \text{ kg/m}^3$ ,  $h_{\text{fg}} = 2393 \text{ kJ/kg}$ ; Table A.6, Water, liquid ( $T_f = (T_s + T_{\text{sat}})/2 = 309 \text{ K}$ ):  $\rho_\ell = 993 \text{ kg/m}^3$ ,  $c_{p,\ell} = 4178 \text{ J/kg}\cdot\text{K}$ ,  $\mu_\ell = 703 \times 10^{-6} \text{ N}\cdot\text{s/m}^2$ ,  $k_\ell = 0.627 \text{ W/m}\cdot\text{K}$ .

**ANALYSIS:** (a) With  $\text{Ja} = c_{p,\ell} \Delta T / h_{\text{fg}} = 4178 \text{ J/kg}\cdot\text{K} \times (319 - 300) \text{ K} / 2393 \times 10^3 \text{ J/kg} = 0.033$ ,  $h'_{\text{fg}} = h_{\text{fg}}(1 + 0.68 \text{ Ja}) = 2393 \text{ kJ/kg}(1 + 0.68 \times 0.033) = 2470 \text{ kJ/kg}$ .

Equation 10.46 may be written for the top tube,

$$\bar{h}_D = 0.729 \left[ \frac{g \rho_\ell (\rho_\ell - \rho_v) k_\ell^3 h'_{\text{fg}}}{\mu_\ell (T_{\text{sat}} - T_s) D} \right]^{1/4}$$

$$\bar{h}_D = 0.729 \left[ \frac{9.8 \text{ m/s}^2 \times 993 \text{ kg/m}^3 (993 - 0.067) \text{ kg/m}^3 (0.627 \text{ W/m}\cdot\text{K})^3 \times 2470 \times 10^3 \text{ J/kg}}{703 \times 10^{-6} \text{ N}\cdot\text{s/m}^2 (319 - 300) \text{ K} \times 0.008 \text{ m}} \right]^{1/4}$$

$$\bar{h}_D = 11,190 \text{ W/m}^2 \cdot \text{K}$$

From Eq. 10.49 the array-averaged convection coefficient is

$$\bar{h}_{D,N} = \bar{h}_D N^n = 11,190 \text{ W/m}^2 \cdot \text{K} \times 10^{-1/6} = 7622 \text{ W/m}^2 \cdot \text{K}$$

Hence, the condensation rate for the entire array per unit tube length is

$$\dot{m}' = 7622 \text{ W/m}^2 \cdot \text{K} (100) \pi \times 0.008 \text{ m} (319 - 300) \text{ K} / 2470 \times 10^3 \text{ J/kg}$$

$$\dot{m}' = 0.147 \text{ kg/s} \cdot \text{m} = 530 \text{ kg/h} \cdot \text{m} \quad \leftarrow$$

(b) Options for increasing the condensation rate include reducing the surface temperature and/or the number of tubes in a vertical tier. The following results were obtained using IHT.

Continued...

### PROBLEM 10.61 (Cont.)

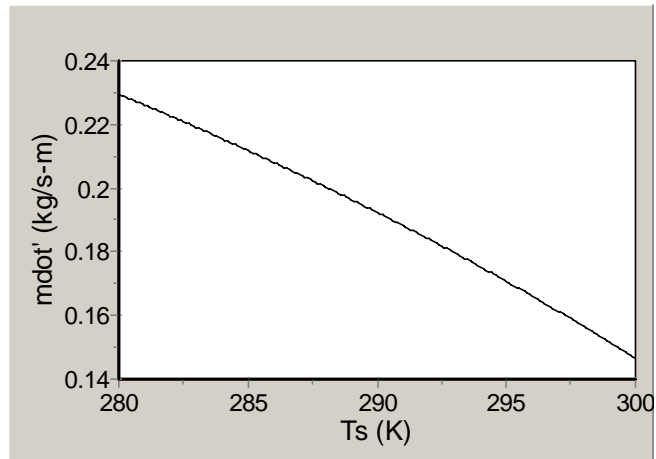

Condensation rate versus tube temperature (10 vertical tubes).

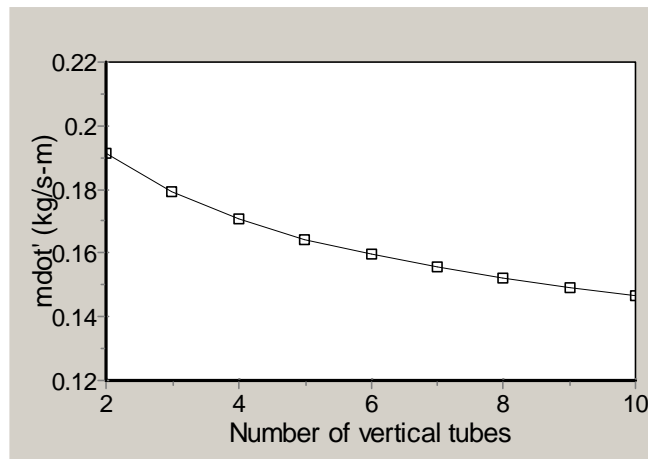

Condensation rate versus number of vertical tubes ( $T_s = 300\text{K}$ ).

**COMMENTS:** Note the sensitivity of the condensation rate to the manner in which the tubes are positioned within the array.

## PROBLEM 10.62

**KNOWN:** Thin-walled concentric tube arrangement for heating deionized water by condensation of steam.

**FIND:** Estimates for convection coefficients on both sides of the inner tube. Inner tube wall outlet temperature. Whether condensation provides fairly uniform inner tube wall temperature approximately equal to the steam saturation temperature.

**SCHEMATIC:**

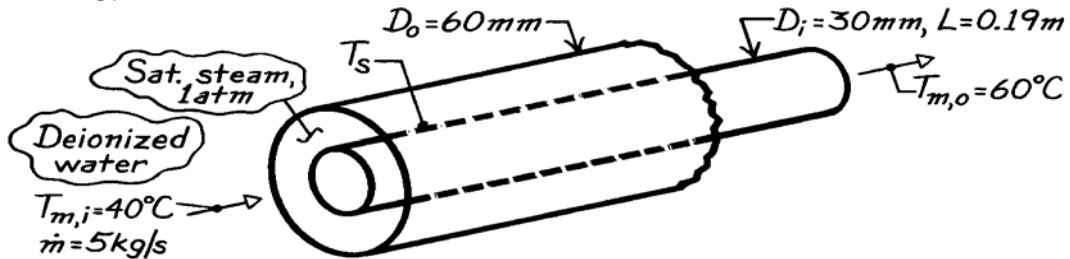

**ASSUMPTIONS:** (1) Negligible thermal resistance of inner tube wall, (2) Internal flow is fully developed.

**PROPERTIES:** Deionized water (given):  $\rho = 982.3 \text{ kg/m}^3$ ,  $c_p = 4181 \text{ J/kg}\cdot\text{K}$ ,  $k = 0.643 \text{ W/m}\cdot\text{K}$ ,  $\mu = 548 \times 10^{-6} \text{ N}\cdot\text{s/m}^2$ ,  $Pr = 3.56$ ; *Table A-6*, Saturated vapor (1 atm):  $T_{\text{sat}} = 100^\circ\text{C}$ ,  $\rho_v = (1/v_g) = 0.596 \text{ kg/m}^3$ ,  $h'_{fg} = 2257 \text{ kJ/kg}$ ; *Table A-6*, Saturated water (assume  $T_s \approx 75^\circ\text{C}$ ,  $T_f = (75 + 100)^\circ\text{C}/2 = 360\text{K}$ ):  $\rho_\ell = (1/v_f) = 967 \text{ kg/m}^3$ ,  $\mu_\ell = 324 \times 10^{-6} \text{ N}\cdot\text{s/m}^2$ ,  $k_\ell = 0.674 \text{ W/m}\cdot\text{K}$ ,  $c_{p,\ell} = 4203 \text{ J/kg}\cdot\text{K}$ .

**ANALYSIS:** From an energy balance on the inner tube at the outlet assuming a constant wall temperature,

$$\bar{h}_c (T_{\text{sat}} - T_s) = h_i (T_s - T_{m,o})$$

where  $\bar{h}_c$  and  $h_i$  are, respectively, the heat transfer coefficients for condensation (c) on a horizontal cylinder and internal (i) flow in a tube.

*Condensation.* From Eq. 10.46, for the horizontal tube,

$$\bar{h}_c = 0.729 \left[ \frac{g \rho_\ell (\rho_\ell - \rho_v) k_\ell^3 h'_{fg}}{\mu_\ell (T_{\text{sat}} - T_s) D} \right]^{1/4}$$

where  $h'_{fg} = h_{fg} \left\{ 1 + 0.68 c_{p,\ell} (T_{\text{sat}} - T_s) / h_{fg} \right\}$

$$h'_{fg} = 2257 \text{ kJ/kg} \left\{ 1 + 0.68 \times 4203 \text{ J/kg}\cdot\text{K} (100 - T_s) / 2257 \times 10^3 \text{ J/kg} \right\}$$

$$h'_{fg} = 2257 \text{ kJ/kg} \left\{ 1 + 1.266 \times 10^{-3} (100 - T_s) \right\}$$

$$\bar{h}_c = 0.729 \left[ 9.8 \text{ m/s}^2 \times 967 \text{ kg/m}^3 (967 - 0.596) \text{ kg/m}^3 (0.674 \text{ W/m}\cdot\text{K})^3 \times \right.$$

$$\left. 2257 \left\{ 1 + 1.266 \times 10^{-3} (100 - T_s) \right\} \text{ kJ/kg} / 324 \times 10^{-6} \text{ N}\cdot\text{s/m}^2 (100 - T_s) 0.030 \text{ m} \right]^{1/4}$$

Continued ...

**PROBLEM 10.62 (Cont.)**

$$\bar{h}_c = 2.071 \times 10^4 \left[ \frac{1 + 1.266 \times 10^{-3} (100 - T_s)}{100 - T_s} \right]^{1/4}.$$

*Internal flow.* From Eq. 8.6, evaluating properties at  $\bar{T}_m$ , find

$$\text{Re}_D = \frac{4\dot{m}}{\pi\mu D} = \frac{4 \times 5 \text{ kg/s}}{\pi \times 548 \times 10^{-6} \text{ N}\cdot\text{s/m}^2 \times 0.030 \text{ m}} = 3.872 \times 10^5$$

and for turbulent flow use the Dittus Boelter equation,

$$\text{Nu}_D = \frac{h_i D}{k} = 0.023 \text{Re}_D^{0.8} \text{Pr}^{0.4}$$

$$h_i = \frac{0.023 \times 0.643 \text{ W/m}\cdot\text{K}}{0.03 \text{ m}} \left( 3.872 \times 10^5 \right)^{0.8} (3.56)^{1/3} = 2.42 \times 10^4 \text{ W/m}^2 \cdot \text{K}. <$$

Substituting numerical values into the energy balance relation,

$$\begin{aligned} 2.071 \times 10^4 \left[ \frac{1 + 1.266 \times 10^{-3} (100 - T_s)}{100 - T_{s,o}} \right]^{1/4} (100 - T_s) \text{ K} \\ = 2.42 \times 10^4 \text{ W/m}^2 \cdot \text{K} (T_s - 60) \text{ K} \end{aligned}$$

and by trial-and-error, find

$$T_s \approx 70.8^\circ\text{C}.$$

With this value of  $T_s$ , find that

$$\bar{h}_c = 8990 \text{ W/m}^2 \cdot \text{K} <$$

which is approximately half that for the internal flow. Hence, the tube wall cannot be at a uniform temperature. This could only be achieved if  $\bar{h}_c \approx h_i$ .

### PROBLEM 10.63

**KNOWN:** Heat dissipation from multichip module to saturated liquid of prescribed temperature and properties. Diameter and inlet and outlet water temperatures for a condenser coil.

**FIND:** (a) Condensation and water flow rates. (b) Tube surface inlet and outlet temperatures. (c) Coil length.

**SCHEMATIC:**

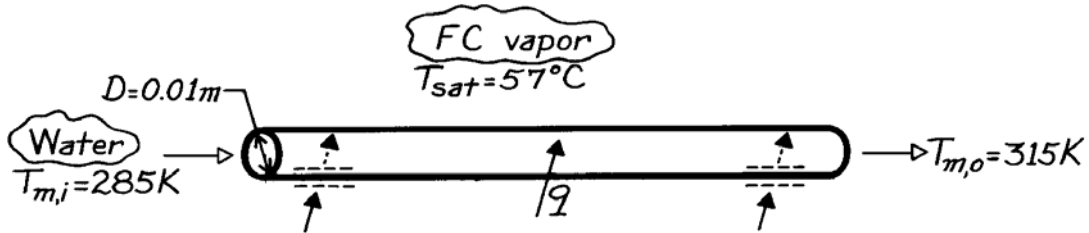

**ASSUMPTIONS:** (1) Steady-state conditions since rate of heat transfer from the module is balanced by rate of heat transfer to coil, (2) Fully developed flow in tube, (3) Water is incompressible liquid with negligible viscous dissipation.

**PROPERTIES:** Saturated fluorocarbon ( $T_{\text{sat}} = 57^\circ\text{C}$ , given):  $k_\ell = 0.0537 \text{ W/m}\cdot\text{K}$ ,  $c_{p,\ell} = 1100 \text{ J/kg}\cdot\text{K}$ ,  $h'_{\text{fg}} \approx h_{\text{fg}} = 84,400 \text{ J/kg}$ .  $\rho_\ell = 1619.2 \text{ kg/m}^3$ ,  $\rho_v = 13.4 \text{ kg/m}^3$ ,  $\sigma = 8.1 \times 10^{-3} \text{ kg/s}^2$ ,  $\mu_\ell = 440 \times 10^{-6} \text{ kg/m}\cdot\text{s}$ ,  $\text{Pr}_\ell = 9$ ; Table A-6, Water, sat. liquid ( $\bar{T}_m = 300\text{K}$ ):  $\rho = 997 \text{ kg/m}^3$ ,  $c_p = 4179 \text{ J/kg}\cdot\text{K}$ ,  $\mu = 855 \times 10^{-6} \text{ N}\cdot\text{s/m}^2$ ,  $k = 0.613 \text{ W/m}\cdot\text{K}$ ,  $\text{Pr} = 5.83$ .

**ANALYSIS:** (a) With

$$q = (q'' \times A)_{\text{module}} = 10^5 \text{ W/m}^2 (0.1 \text{ m})^2 = 10^3 \text{ W}$$

the condensation rate is

$$\dot{m}_{\text{con}} = \frac{q}{h'_{\text{fg}}} = \frac{10^3 \text{ W}}{84,400 \text{ J/kg}} = 0.0118 \text{ kg/s} \quad <$$

and the required water flow rate is

$$\dot{m} = \frac{q}{c_p (T_{m,o} - T_{m,i})} = \frac{1000 \text{ W}}{4179 \text{ J/kg}\cdot\text{K} (30 \text{ K})} = 7.98 \times 10^{-3} \text{ kg/s} \quad <$$

(b) The Reynolds number for flow through the tube is

$$\text{Re}_D = \frac{4 \dot{m}}{\pi D \mu} = \frac{4 \times 7.98 \times 10^{-3} \text{ kg/s}}{\pi (0.01 \text{ m}) 855 \times 10^{-6} \text{ N}\cdot\text{s/m}^2} = 1188.$$

Hence, the flow is laminar. Assuming a uniform wall temperature,

$$h_i = \text{Nu}_D k / D = 3.66 (0.613 \text{ W/m}\cdot\text{K} / 0.01 \text{ m}) = 224 \text{ W/m}^2 \cdot \text{K}.$$

Continued ...

**PROBLEM 10.63 (Cont.)**

For film condensation on the outer surface, Eq. 10.46 yields

$$h_o = 0.729 \left[ \frac{9.8 \text{ m/s}^2 \left( 1619.2 \text{ kg/m}^3 \right) \left( 1605.8 \text{ kg/m}^3 \right) \left( 0.0537 \text{ W/m}\cdot\text{K} \right)^3 84,400 \text{ J/kg}}{440 \times 10^{-6} \text{ kg/m}\cdot\text{s} \times 0.01 \text{ m} (T_{\text{sat}} - T_s)} \right]^{1/4}$$

$$h_o = 2150(57 - T_s)^{-1/4}.$$

From an energy balance on a portion of the tube surface,

$$h_o (T_{\text{sat}} - T_s) = h_i (T_s - T_m)$$

or

$$2150(57 - T_s)^{3/4} = 224(T_s - T_m)$$

At the entrance where  $(T_{m,i} = 285\text{K})$ , trial-and-error yields:

$$T_{s,i} = 50.6^\circ\text{C} \quad <$$

and at the exit where  $(T_{m,o} = 315\text{K})$ ,

$$T_{s,o} = 55.4^\circ\text{C} \quad <$$

We use an average value of  $T_s \approx 53^\circ\text{C}$  in the following.

(c) From Eqs. 8.43 and 8.44,

$$L = \frac{q}{h_i \pi D \Delta T_{\ell m}}$$

where

$$\Delta T_{\ell m} = \frac{(T_s - T_{m,i}) - (T_s - T_{m,o})}{\ln \left[ (T_s - T_{m,i}) / (T_s - T_{m,o}) \right]} = \frac{41 - 11}{\ln(41/11)} = 22.8^\circ\text{C}$$

$$L = \frac{1000 \text{ W}}{(224 \text{ W/m}^2 \cdot \text{K}) \pi (0.01 \text{ m}) 22.8^\circ\text{C}} = 6.23 \text{ m.} \quad <$$

**COMMENTS:** Some control over system performance may be exercised by adjusting the water flow rate. By increasing  $\dot{m}$ ,  $(T_{m,o} - T_{m,i})$  is reduced for a prescribed  $q$ . The value of  $h_i$  is increased substantially if the internal flow is turbulent.

### PROBLEM 10.64

**KNOWN:** Saturated ethylene glycol vapor at 1 atm condensing on a sphere of 100 mm diameter having surface temperature of 150°C.

**FIND:** Condensation rate.

**SCHEMATIC:**

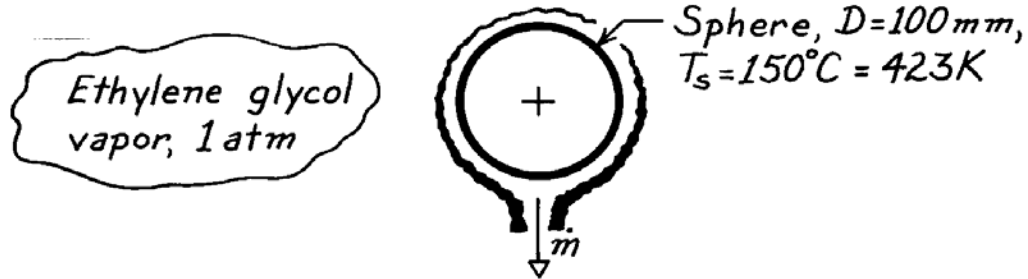

**ASSUMPTIONS:** (1) Laminar film condensation, (2) Negligible non-condensibles in vapor.

**PROPERTIES:** Table A-5, Saturated ethylene glycol, vapor (1 atm):  $T_{\text{sat}} = 470\text{ K}$ ,  $\rho_v \approx 0\text{ kg/m}^3$ ,  $h_{\text{fg}} = 812\text{ kJ/kg}$ ; Table A-5, Ethylene glycol, liquid ( $T_f = 423\text{ K}$ , but use values at 373 K, limit of data in table):  $\rho_\ell = 1058.5\text{ kg/m}^3$ ,  $c_{p,\ell} = 2742\text{ J/kg}\cdot\text{K}$ ,  $\mu_\ell = 0.215 \times 10^{-2}\text{ N}\cdot\text{s/m}^2$ ,  $k_\ell = 0.263\text{ W/m}\cdot\text{K}$ .

**ANALYSIS:** The condensation rate is given by Eq. 10.34 as

$$\dot{m} = \frac{q}{h'_{\text{fg}}} = \frac{\bar{h}_L (\pi D^2) (T_{\text{sat}} - T_s)}{h'_{\text{fg}}}$$

where  $A = \pi D^2$  for the sphere and  $h'_{\text{fg}}$ , with  $\text{Ja} = c_{p,\ell} \Delta T / h_{\text{fg}}$ , is given by Eq. 10.27 as

$$h'_{\text{fg}} = h_{\text{fg}} (1 + 0.68 \text{Ja}) = 812 \frac{\text{kJ}}{\text{kg}} \left( 1 + 0.68 \times 2742 \frac{\text{J}}{\text{kg}\cdot\text{K}} (470 - 423)\text{ K} / 812 \times 10^3 \text{ J/kg} \right) = 900 \text{ kJ/kg}.$$

The average heat transfer coefficient for the sphere follows from Eq. 10.46 with  $C = 0.826$ ,

$$\bar{h}_D = 0.826 \left[ \frac{g \rho_\ell (\rho_\ell - \rho_v) k_\ell^3 h'_{\text{fg}}}{\mu_\ell (T_{\text{sat}} - T_s) D} \right]^{1/4}$$

$$\bar{h}_D = 0.826 \left[ \frac{9.8 \text{ m/s}^2 \times 1058.5 \text{ kg/m}^3 (1058.5 - 0) \text{ kg/m}^3 (0.263 \text{ W/m}\cdot\text{K})^3 \times 900 \times 10^3 \text{ J/kg}}{0.215 \times 10^{-2} \text{ N}\cdot\text{s/m}^2 (470 - 423) \text{ K} \times 0.100 \text{ m}} \right]^{1/4}$$

$$\bar{h}_D = 1696 \text{ W/m}^2 \cdot \text{K}.$$

Hence, the condensation rate is

$$\dot{m} = 1696 \text{ W/m}^2 \cdot \text{K} \times \pi (0.100 \text{ m})^2 (470 - 423) \text{ K} / 900 \times 10^3 \text{ J/kg}$$

$$\dot{m} = 2.78 \times 10^{-3} \text{ kg/s}.$$

<

**COMMENTS:** Recognize this estimate is likely to be a poor one since properties were not evaluated at the proper  $T_f$  which was beyond the limit of the table.

### PROBLEM 10.65

**KNOWN:** Copper sphere of 10 mm diameter, initially at 50°C, is placed in a large container filled with saturated steam at 1 atm.

**FIND:** Time required for sphere to reach equilibrium and the condensate formed during this period.

**SCHEMATIC:**

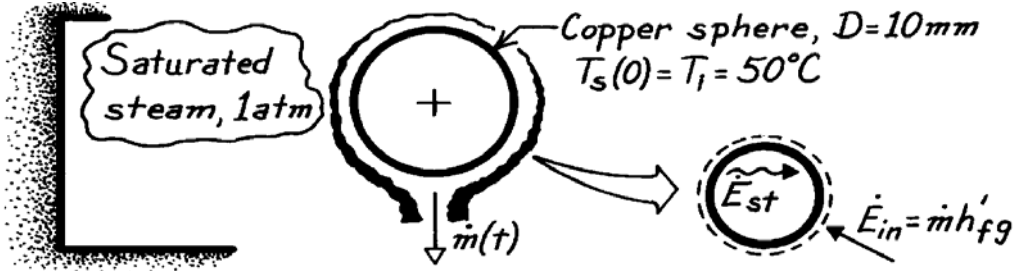

**ASSUMPTIONS:** (1) Laminar film condensation, (2) Negligible non-condensables in vapor, (3) Sphere is spacewise isothermal, (4) Sphere experiences heat gain by condensation only.

**PROPERTIES:** Table A-6, Saturated water vapor (1 atm):  $T_{\text{sat}} = 100^\circ\text{C}$ ,  $\rho_v = 0.596 \text{ kg/m}^3$ ,  $h_{\text{fg}} = 2257 \text{ kJ/kg}$ ; Table A-6, Water, liquid ( $T_f \approx (75 + 100)^\circ\text{C}/2 = 360\text{K}$ ):  $\rho_\ell = 967.1 \text{ kg/m}^3$ ,  $c_{p,\ell} = 4203 \text{ J/kg}\cdot\text{K}$ ,  $\mu_\ell = 324 \times 10^{-6} \text{ N}\cdot\text{s/m}^2$ ,  $k_\ell = 0.674 \text{ W/m}\cdot\text{K}$ ; Table A-1, Copper, pure ( $\bar{T} = 75^\circ\text{C}$ ):  $\rho_{\text{sp}} = 8933 \text{ kg/m}^3$ ,  $c_{p,\text{sp}} = 389 \text{ J/kg}\cdot\text{K}$ .

**ANALYSIS:** Using the lumped capacitance approach, an energy balance on the sphere provides,

$$\dot{E}_{\text{in}} - \dot{E}_{\text{out}} = \dot{E}_{\text{st}}$$

$$\dot{m} h'_{\text{fg}} = \bar{h}_D A_s (T_{\text{sat}} - T_s) = \rho_{\text{sp}} c_{p,\text{sp}} V_s \frac{dT_s}{dt}. \quad (1)$$

Properties of the sphere,  $\rho_{\text{sp}}$  and  $c_{p,\text{sp}}$ , will be evaluated at  $\bar{T}_s = (50 + 100)^\circ\text{C}/2 = 75^\circ\text{C}$ , while water (liquid) properties will be evaluated at  $\bar{T}_f = (\bar{T}_s + T_{\text{sat}})/2 = 87.5^\circ\text{C} \approx 360\text{K}$ . From Eq. 10.27 with  $\text{Ja} = c_{p,\ell} \Delta T / h_{\text{fg}}$  where  $\Delta T = T_{\text{sat}} - \bar{T}_s$ , find

$$h'_{\text{fg}} = h_{\text{fg}} (1 + 0.68 \text{Ja}) = 2257 \frac{\text{kJ}}{\text{kg}} \left( 1 + 0.68 \left[ 4203 \frac{\text{J}}{\text{kg}\cdot\text{K}} \times (100 - 75) \text{K} / 2257 \times 10^3 \text{J/kg} \right] \right) = 2328 \frac{\text{kJ}}{\text{kg}}. \quad (2)$$

To estimate the time required to reach equilibrium, we need to integrate Eq. (1) with appropriate limits. However, to perform the integration, an appropriate relation for the temperature dependence of  $\bar{h}_D$  needs to be found, as discussed in Chapter 5. Using Eq. 10.46 with  $C = 0.826$ ,

$$\bar{h}_D = 0.826 \left[ \frac{g \rho_\ell (\rho_\ell - \rho_v) k_\ell^3 h'_{\text{fg}}}{\mu_\ell (T_{\text{sat}} - T_s) D} \right]^{1/4}.$$

Substitute numerical values and find,

$$\bar{h}_D = 0.826 \left[ \frac{9.8 \text{ m/s}^2 \times 967.1 \text{ kg/m}^3 (967.1 - 0.596) \text{ kg/m}^3 (0.674 \text{ W/m}\cdot\text{K})^3 \times 2328 \times 10^3 \text{ J/kg}}{324 \times 10^{-6} \text{ N}\cdot\text{s/m}^2 (T_{\text{sat}} - T_s) \times 0.010 \text{ m}} \right]^{1/4}$$

$$\bar{h}_D = B (T_{\text{sat}} - T_s)^{-1/4} \quad \text{where} \quad B = 31,120 \text{ W/m}^2 \cdot (\text{K})^{3/4}. \quad (3)$$

Continued ...



**PROBLEM 10.65 (Cont.)**

Substitute Eq. (3) into Eq. (1) for  $\bar{h}_D$  and recognize  $V_s / A_s = \frac{1}{6} \pi D^3 / \pi D^2 = D/6$ ,

$$B(T_{\text{sat}} - T_s)^{-1/4} (T_{\text{sat}} - T_s) = \rho_{\text{sp}} c_{p,\text{sp}} (D/6) \frac{dT_s}{dt}. \quad (4)$$

Note that  $d(T_s) = -d(T_{\text{sat}} - T_s)$ ; letting  $\Delta T \equiv T_{\text{sat}} - T_s$  and separating variables, the energy balance relation has the form

$$\int_0^t dt = -\frac{\rho_{\text{sp}} c_{p,\text{sp}} (D/6)}{B} \int_{\Delta T_o}^{\Delta T} \frac{d(\Delta T)}{\Delta T^{3/4}} \quad (5)$$

where the limits of integration have been identified, with  $\Delta T_o = T_{\text{sat}} - T_i$  and  $T_i = T_s(0)$ . Performing the integration, find

$$t = -\frac{\rho_{\text{sp}} c_{p,\text{sp}} (D/6)}{B} \cdot \frac{1}{1-3/4} \left[ \Delta T^{1/4} - \Delta T_o^{1/4} \right].$$

Substituting numerical values with the limits,  $\Delta T = 0$  and  $\Delta T_o = 100 - 50 = 50^\circ\text{C}$ ,

$$t = -\frac{8933 \text{ kg/m}^3 \times 389 \text{ J/kg} \cdot \text{K} (0.010 \text{ m}/6)}{31,120 \text{ W/m}^2 \cdot \text{K}^{3/4}} \times 4 \left[ 0^{1/4} - 50^{1/4} \right] \text{K}^{1/4}$$

$$t = 2.0 \text{ s.} \quad <$$

To determine the total amount of condensate formed during this period, perform an energy balance on a time interval basis,

$$E_{\text{in}} - E_{\text{out}} = \Delta E = E_{\text{final}} - E_{\text{initial}}$$

$$E_{\text{in}} = \rho_{\text{sp}} c_{p,\text{sp}} V (T_{\text{final}} - T_{\text{initial}}) \quad (6)$$

where  $T_{\text{final}} = T_{\text{sat}}$  and  $T_{\text{initial}} = T_i = T_s(0)$ . Recognize that

$$E_{\text{in}} = M h'_{\text{fg}} \quad (7)$$

where  $M$  is the total mass of vapor that condenses. Combining Eqs. (6) and (7),

$$M = \frac{\rho_{\text{sp}} c_{p,\text{sp}} V}{h'_{\text{fg}}} [T_{\text{sat}} - T_i]$$

$$M = \frac{8933 \text{ kg/m}^3 \times 389 \text{ J/kg} \cdot \text{K} (\pi/6) (0.010 \text{ m})^3}{2328 \times 10^3 \text{ J/kg}} [100 - 50] \text{K}$$

$$M = 3.91 \times 10^{-5} \text{ kg.} \quad <$$

**COMMENTS:** The total amount of condensate could have been evaluated from the integral,

$$M = \int_0^t \dot{m} dt = \int_0^t \frac{q}{h'_{\text{fg}}} dt = \int_0^t \frac{\bar{h}_D A_s (T_{\text{sat}} - T_s) dt}{h'_{\text{fg}}}$$

giving the same result, but with more effort.

### PROBLEM 10.66

**KNOWN:** Saturation temperature and inlet flow rate of refrigerant. Diameter, length, and temperature of tube.

**FIND:** Rate of condensation and outlet flow rate.

**SCHEMATIC:**

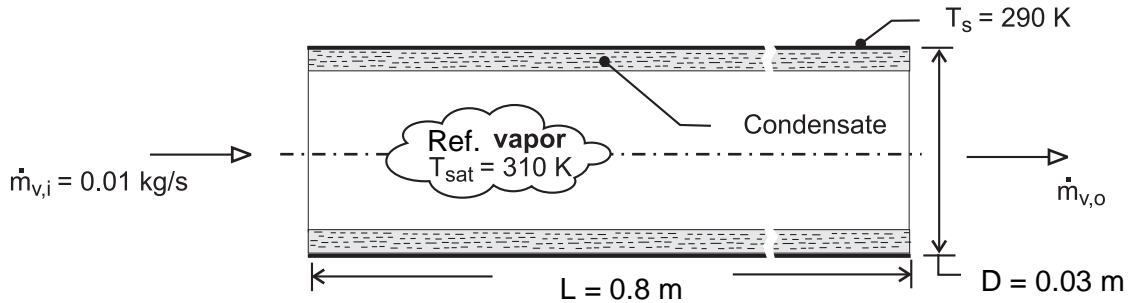

**ASSUMPTIONS:** (1) Negligible concentration of noncondensable gases in vapor.

**PROPERTIES:** Given, R-12, saturated vapor ( $T_{\text{sat}} = 310 \text{ K}$ ):  $\rho_v = 50.1 \text{ kg/m}^3$ ,  $h_{\text{fg}} = 160 \text{ kJ/kg}$ ,  $\mu_v = 150 \times 10^{-7} \text{ N}\cdot\text{s/m}^2$ . Saturated liquid ( $T_f = 300 \text{ K}$ ):  $\rho_\ell = 1306 \text{ kg/m}^3$ ,  $c_{p,\ell} = 978 \text{ J/kg}\cdot\text{K}$ ,  $\mu_\ell = 0.0254 \times 10^{-2} \text{ N}\cdot\text{s/m}^2$ ,  $k_\ell = 0.072 \text{ W/m}\cdot\text{K}$ . R-134a, saturated vapor ( $T_{\text{sat}} = 310 \text{ K}$ ):  $\rho_v = 46.1 \text{ kg/m}^3$ ,  $h_{\text{fg}} = 166 \text{ kJ/kg}$ ,  $\mu_v = 136 \times 10^{-7} \text{ N}\cdot\text{s/m}^2$ . *Table A.5:* R-134a, Saturated liquid ( $T_f = 300 \text{ K}$ ):  $\rho_\ell = 1199.7 \text{ kg/m}^3$ ,  $c_{p,\ell} = 1432 \text{ J/kg}\cdot\text{K}$ ,  $\mu_\ell = 0.01905 \times 10^{-2} \text{ N}\cdot\text{s/m}^2$ ,  $k_\ell = 0.0803 \text{ W/m}\cdot\text{K}$ .

**ANALYSIS: For R-12:** The Reynolds number associated with the inlet vapor flow is

$Re_{v,i} = 4 \dot{m}_{v,i} / \pi D \mu_v = 0.04 \text{ kg/s} / \pi \times 0.03 \text{ m} \times 150 \times 10^{-7} \text{ N}\cdot\text{s/m}^2 = 28,290 < 35,000$ . Hence, the average convection coefficient may be obtained from Eq. 10.46 with  $C = 0.555$ , where  $h'_{\text{fg}} = h_{\text{fg}} + 0.375 c_{p,\ell} (T_{\text{sat}} - T_s) = (1.6 \times 10^5 + 0.375 \times 978 \times 20) \text{ J/kg} = 1.67 \times 10^5 \text{ J/kg}$ .

$$\bar{h}_D = 0.555 \left[ \frac{g \rho_\ell (\rho_\ell - \rho_v) k_\ell^3 h'_{\text{fg}}}{\mu_\ell (T_{\text{sat}} - T_s) D} \right]^{1/4} = 0.555 \left[ \frac{9.8 \text{ m/s}^2 \times 1306 \text{ kg/m}^3 (1306 - 50.1) \text{ kg/m}^3 (0.072 \text{ W/m}\cdot\text{K})^3 1.67 \times 10^5 \text{ J/kg}}{0.0254 \times 10^{-2} \text{ N}\cdot\text{s/m}^2 \times 20 \text{ K} \times 0.03 \text{ m}} \right]^{1/4}$$

$$\bar{h}_D = 889 \text{ W/m}^2 \cdot \text{K}$$

The heat rate is then

$$q = \pi D L \bar{h}_D (T_{\text{sat}} - T_s) = \pi \times 0.03 \text{ m} \times 0.8 \text{ m} \times 889 \text{ W/m}^2 \cdot \text{K} \times 20 \text{ K} = 1340 \text{ W}$$

and the condensation rate is

$$\dot{m}_{\text{cond}} = \frac{q}{h'_{\text{fg}}} = \frac{1340 \text{ W}}{1.67 \times 10^5} = 0.0080 \text{ kg/s} \quad <$$

The flow rate of vapor leaving the tube is then

$$\dot{m}_{v,o} = \dot{m}_{v,i} - \dot{m}_{\text{cond}} = (0.0100 - 0.0080) \text{ kg/s} = 0.0020 \text{ kg/s} \quad <$$

Continued...

**PROBLEM 10.66 (Cont.)**

Repeating the analysis for R-134a, we find that  $\bar{h}_D = 1007 \text{ W/m}^2 \cdot \text{K}$ ,  $q = 1520 \text{ W}$ ,

$\dot{m}_{\text{cond}} = 0.0086 \text{ kg/s}$ , and  $\dot{m}_{\text{v,o}} = 0.0014 \text{ kg/s}$ .

<

**COMMENTS:** The behavior of the two refrigerants is comparable since the properties are similar, and R-134a could replace R-12 in many applications. The R-134a provides somewhat higher heat transfer and condensation rates in this application.

### PROBLEM 10.67

**KNOWN:** Saturated steam condensing on the inside of a horizontal pipe.

**FIND:** Heat transfer coefficient and the condensation rate per unit length of the pipe.

**SCHEMATIC:**

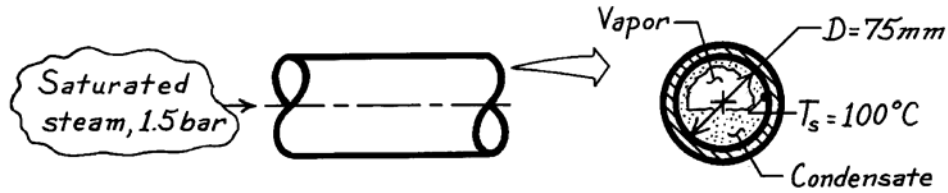

**ASSUMPTIONS:** (1) Film condensation with low vapor velocities.

**PROPERTIES:** Table A-6, Saturated water vapor (1.5 bar):  $T_{\text{sat}} \approx 385 \text{ K}$ ,  $\rho_v = 0.88 \text{ kg/m}^3$ ,  $h_{\text{fg}} = 2225 \text{ kJ/kg}$ ; Table A-6, Saturated water ( $T_f = (T_{\text{sat}} + T_s)/2 \approx 380 \text{ K}$ ):  $\rho_\ell = 953.3 \text{ kg/m}^3$ ,  $c_{p,\ell} = 4226 \text{ J/kg}\cdot\text{K}$ ,  $\mu_\ell = 260 \times 10^{-6} \text{ N}\cdot\text{s/m}^2$ ,  $k_\ell = 0.683 \text{ W/m}\cdot\text{K}$ .

**ANALYSIS:** The condensation rate per unit length follows from Eq. 10.34 with  $A = \pi D L$  and has the form

$$\dot{m}' = \frac{\dot{m}}{L} = \bar{h}_D (\pi D) (T_{\text{sat}} - T_s) / h'_{\text{fg}}$$

where  $\bar{h}_D$  is estimated from the correlation of Eq. 10.46 with the expression for  $h'_{\text{fg}}$  following the discussion after Eq. 10.50,

$$\bar{h}_D = 0.555 \left[ \frac{g \rho_\ell (\rho_\ell - \rho_v) k_\ell^3 h'_{\text{fg}}}{\mu_\ell (T_{\text{sat}} - T_s) D} \right]^{1/4}$$

where

$$h'_{\text{fg}} = h_{\text{fg}} + \frac{3}{8} c_{p,\ell} (T_{\text{sat}} - T_s) = 2225 \times 10^3 \frac{\text{J}}{\text{kg}} + \frac{3}{8} \times 4226 \frac{\text{J}}{\text{kg}\cdot\text{K}} (385 - 373) \text{ K}$$

$$h'_{\text{fg}} = 2244 \text{ kJ/kg.}$$

Hence,

$$\bar{h}_D = 0.555 \left[ \frac{9.8 \text{ m/s}^2 \times 953.3 \frac{\text{kg}}{\text{m}^3} (953.3 - 0.88) \frac{\text{kg}}{\text{m}^3} (0.683 \text{ W/m}\cdot\text{K})^3 2244 \times 10^3 \text{ J/kg}}{260 \times 10^{-6} \text{ N}\cdot\text{s/m}^2 (385 - 373) \text{ K} \times 0.075 \text{ m}} \right]^{1/4}$$

$$\bar{h}_D = 7127 \text{ W/m}^2 \cdot \text{K.}$$

It follows that the condensate rate per unit length of the tube is

$$\dot{m}' = 7127 \text{ W/m}^2 \cdot \text{K} (\pi \times 0.075 \text{ m}) (385 - 373) \text{ K} / 2244 \times 10^3 \text{ J/kg} = 9.0 \times 10^{-3} \text{ kg/s}\cdot\text{m.} \quad <$$

### PROBLEM 10.68

**KNOWN:** Pressure of saturated steam condensing on the inside of a horizontal pipe. Diameter and surface temperature of pipe. Mass flow rate.

**FIND:** (a) Heat transfer coefficient and condensation rate per unit length of the pipe for  $X = 0.2$ . (b) Plot heat transfer coefficient and condensation rate for  $0.1 \leq X \leq 0.3$ .

**SCHEMATIC:**

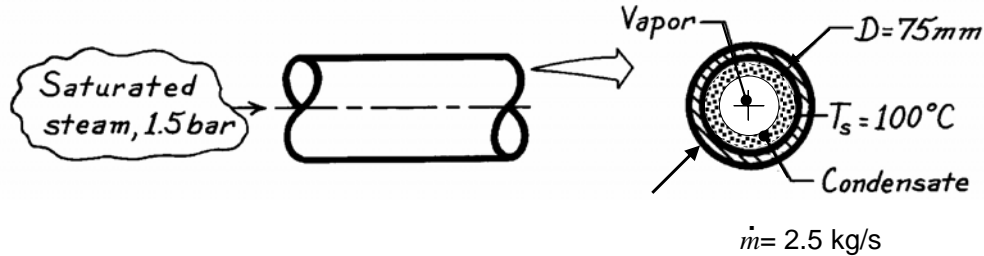

**ASSUMPTIONS:** (1) Film condensation with high vapor velocities, annular flow.

**PROPERTIES:** Table A-6, Saturated water (1.5 bar):  $T_{\text{sat}} \approx 385 \text{ K}$ ,  $\rho_l = 949.7 \text{ kg/m}^3$ ,  $\rho_v = 0.88 \text{ kg/m}^3$ ,  $h_{fg} = 2225 \text{ kJ/kg}$ ,  $c_{p,l} = 4.232 \text{ kJ/kg}$ ,  $\mu_l = 248 \times 10^{-6} \text{ N} \cdot \text{s/m}^2$ ,  $\mu_v = 12.49 \times 10^{-6} \text{ N} \cdot \text{s/m}^2$ ,  $k_l = 0.685 \text{ W/m} \cdot \text{K}$ ,  $Pr_l = 1.53$ .

**ANALYSIS:** The mass flow rate per unit cross sectional tube area is

$$\frac{\dot{m}}{A_c} = \frac{2.5 \text{ kg/s}}{\pi(0.075 \text{ m})^2 / 4} = 566 \text{ kg/s} \cdot \text{m}^2$$

Since this exceeds  $500 \text{ kg/s} \cdot \text{m}^2$ , the Dobson and Chato correlation, Eq. 10.51a can be used. The Reynolds number is

$$Re_{D,l} = 4\dot{m}(1 - X) / (\pi D \mu_l) = 4 \times 2.5 \text{ kg/s} \times (1 - 0.2) / (\pi \times 0.075 \text{ m} \times 248 \times 10^{-6} \text{ N} \cdot \text{s/m}^2) = 1.37 \times 10^5$$

and the Martinelli parameter is

$$X_u = \left( \frac{1 - X}{X} \right)^{0.9} \left( \frac{\rho_v}{\rho_l} \right)^{0.5} \left( \frac{\mu_l}{\mu_v} \right)^{0.1} = \left( \frac{1 - 0.2}{0.2} \right)^{0.9} \left( \frac{0.88}{949.7} \right)^{0.5} \left( \frac{248}{12.49} \right)^{0.1} = 0.143$$

Then,

$$Nu_D = \frac{hD}{k_l} = 0.023 Re_{D,l}^{0.8} Pr_l^{0.4} \left[ 1 + \frac{2.22}{X_u^{0.89}} \right] = 0.023 \times (1.37 \times 10^5)^{0.8} \times 1.53^{0.4} \left[ 1 + \frac{2.22}{0.143^{0.89}} \right] = 4750$$

The heat transfer coefficient is

$$h = Nu_D k_l / D = 4750 \times 0.685 \text{ W/m} \cdot \text{K} / 0.075 \text{ m} = 43,300 \text{ W/m}^2 \cdot \text{K}$$

<

Continued...

### PROBLEM 10.68 (Cont.)

The condensation rate per unit length follows from Eq. 10.34 with  $A = \pi DL$  and

$$h'_{fg} = h_{fg} + 0.375c_{p,l}(T_{\text{sat}} - T_s) = 2225 \text{ kJ/kg} + 0.375 \times 4.232 \text{ kJ/kg} \cdot \text{K} \times (385 - 373) \text{ K} = 2244 \text{ kJ/kg}.$$

Thus,

$$\dot{m}'_{\text{cond}} = \frac{\dot{m}_{\text{cond}}}{L} = h(\pi D)(T_{\text{sat}} - T_s) / h'_{fg}$$

$$= 43,400 \text{ W/m}^2 \cdot \text{K} \times \pi \times 0.075 \text{ m} \times (385 - 373) \text{ K} / 2244 \times 10^3 \text{ J/kg} = 0.0546 \text{ kg/s} \cdot \text{m} \quad \leftarrow$$

(b) Solving the same equations for  $0.1 \leq X \leq 0.3$  yields the plots below.

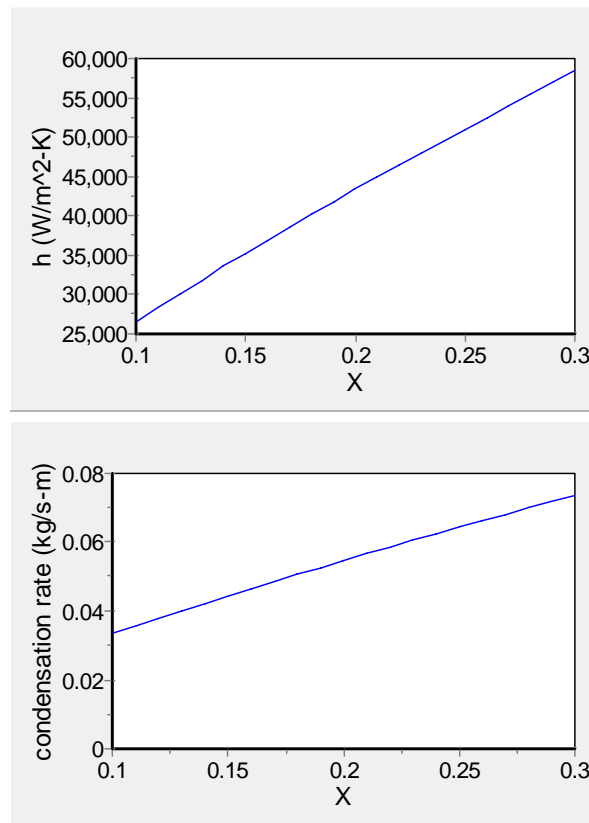

**COMMENTS:** (1) The value of  $X$  strongly impacts the heat transfer coefficient and condensation rate. (2) The condensation rate corresponding to the low vapor velocity case of Problem 10.67 is  $9.0 \times 10^{-3} \text{ kg/s} \cdot \text{m}$ . The higher vapor velocity yields a six-fold increase in heat transfer coefficient and condensation rate. (3) If the fluid were all vapor at the inlet,  $X = 1$ , the vapor velocity would be  $u_v = \dot{m} / (\rho_v A_c) = 2.5 / (0.88 \text{ kg/m}^3 \times \pi (0.075 \text{ m})^2 / 4) = 643 \text{ m/s}$ . The inlet Reynolds number would then be  $3.4 \times 10^6$ , and the criterion for the low vapor velocity solution, Eq. 10.50 would not be satisfied. (4) Treating water vapor as an ideal gas, the speed of sound at 385 K would be 479 m/s as determined in Comment 5. The mass flow rate specified in the problem could not be achieved in a tube of constant cross-sectional area with  $X = 1$ . (5) For water at  $T = 385 \text{ K}$  and  $p = 1.5 \text{ bar}$ ,  $R \equiv \mathcal{R}/M = 8315 \text{ J/kmol} \cdot \text{K} / 18 \text{ kg/kmol} = 462 \text{ J/kg}$ . The specific heat at constant volume is  $c_v \equiv c_p - R = 2080 \text{ J/kg} \cdot \text{K} - 462 \text{ J/kg} \cdot \text{K} = 1618 \text{ J/kg} \cdot \text{K}$ . Therefore the specific heat ratio is  $\gamma = c_p/c_v = 2080 \text{ J/kg} \cdot \text{K} / 1618 \text{ J/kg} \cdot \text{K} = 1.29$  and the speed of sound is  $a = \sqrt{1.29 \times 462 \text{ J/kg} \cdot \text{K} \times 385 \text{ K}} = 479 \text{ m/s}$ .

### PROBLEM 10.69

**KNOWN:** Mass flow rate and quality of R-22 condensing in tube. Tube diameter. Wall and saturation temperatures. Refrigerant properties.

**FIND:** Heat transfer coefficient, heat transfer rate, and condensation rate for (a)  $X = 0.5$ , (b)  $0.2 < X < 0.8$ .

**SCHEMATIC:**

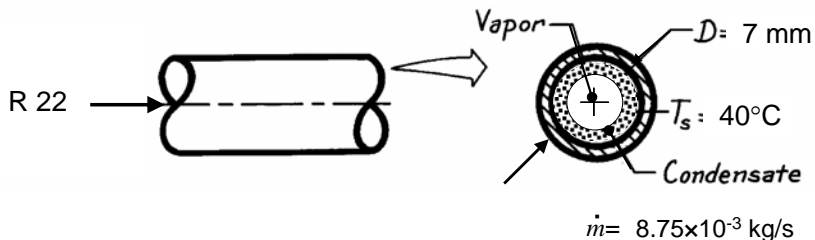

**ASSUMPTIONS:** (1) Film condensation with high vapor velocities, annular flow. (2) Heat of vaporization not strong function of temperature.

**PROPERTIES:** Refrigerant R-22 ( $T_{\text{sat}} = 318 \text{ K}$ ): Given  $\rho_v = 77 \text{ kg/m}^3$ ,  $\mu_v = 15 \times 10^{-6} \text{ N}\cdot\text{s/m}^2$ ; Table A-5,  $\rho_l = 1106 \text{ kg/m}^3$ ,  $\mu_l = 131 \times 10^{-6} \text{ N}\cdot\text{s/m}^2$ ,  $c_{p,l} = 1377 \text{ J/kg}\cdot\text{K}$ ,  $k_l = 0.0741 \text{ W/m}\cdot\text{K}$ ,  $Pr_l = 2.4$ ,  $h_{fg} = 234 \text{ kJ/kg}$ .

**ANALYSIS:** The mass flow rate per unit cross sectional tube area is

$$\frac{\dot{m}}{A_c} = \frac{8.75 \times 10^{-3} \text{ kg/s}}{\pi(0.007 \text{ m})^2 / 4} = 227 \text{ kg/s}\cdot\text{m}^2$$

Although this is below the recommended threshold of  $500 \text{ kg/s}\cdot\text{m}^2$ , since annular flow was observed, the Dobson and Chato correlation, Eq. 10.51a can be used. The Reynolds number is

$Re_{D,l} = 4\dot{m}(1-X) / (\pi D \mu_l) = 4 \times 8.75 \times 10^{-3} \text{ kg/s} \times (1-0.5) / (\pi \times 0.007 \text{ m} \times 131 \times 10^{-6} \text{ N}\cdot\text{s/m}^2) = 6070$   
and the Martinelli parameter is

$$X_{tt} = \left( \frac{1-X}{X} \right)^{0.9} \left( \frac{\rho_v}{\rho_l} \right)^{0.5} \left( \frac{\mu_l}{\mu_v} \right)^{0.1} = \left( \frac{1-0.5}{0.5} \right)^{0.9} \left( \frac{77}{1106} \right)^{0.5} \left( \frac{131}{15} \right)^{0.1} = 0.328$$

Then,

$$Nu_D = \frac{hD}{k_l} = 0.023 Re_{D,l}^{0.8} Pr_l^{0.4} \left[ 1 + \frac{2.22}{X_{tt}^{0.89}} \right] = 0.023 \times (6070)^{0.8} \times 2.4^{0.4} \left[ 1 + \frac{2.22}{0.328^{0.89}} \right] = 243$$

The heat transfer coefficient and heat transfer rate per unit length are

$$h = Nu_D k_l / D = 243 \times 0.0741 \text{ W/m}\cdot\text{K} / 0.007 \text{ m} = 2570 \text{ W/m}^2\cdot\text{K} \quad <$$

$$q'_s = h\pi D(T_{\text{sat}} - T_s) = 2570 \text{ W/m}^2\cdot\text{K} \times \pi \times 0.007 \text{ m} \times (45 - 40)^\circ\text{C} = 283 \text{ W/m}^2 \quad <$$

Continued...

### PROBLEM 10.69 (Cont.)

The condensation rate per unit length follows from Eq. 10.34 with  $A = \pi DL$  and

$$h'_{fg} = h_{fg} + 0.375c_{p,l}(T_{\text{sat}} - T_s) = 234 \text{ kJ/kg} + 0.375 \times 1.377 \text{ kJ/kg} \cdot \text{K} \times (45 - 40)^\circ\text{C} = 237 \text{ kJ/kg} . \text{ Thus,}$$

$$\dot{m}'_{\text{cond}} = q'_s / h'_{fg} = 283 \text{ W/m}^2 / 237 \times 10^3 \text{ J/kg} = 1.19 \times 10^{-3} \text{ kg/s} \cdot \text{m} \quad \leftarrow$$

(b) Solving the same equations for  $0.2 < X < 0.8$  yields the condensation rate plot below.

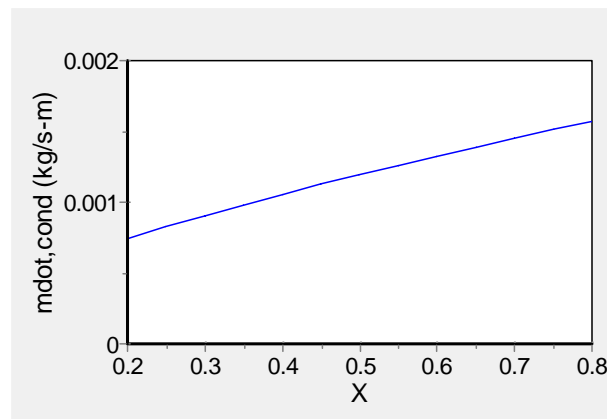

**COMMENTS:** (1) The value of  $X$  strongly impacts the heat transfer coefficient, heat transfer rate, and condensation rate. (2) This problem corresponds to one of the experimental conditions on which the Dobson and Chato correlation is based. Annular flow was observed for this and many, but not all, of the other cases for which the mass flow rate per unit area was less than  $500 \text{ kg/s} \cdot \text{m}^2$ . Annular flow was always observed for values greater than  $500 \text{ kg/s} \cdot \text{m}^2$ . Hence the recommended threshold value of  $\dot{m} / A_c = 500 \text{ kg/s} \cdot \text{m}^2$  is conservative. <



### PROBLEM 10.70

**KNOWN:** Inner and outer diameter of brass tube. Thickness of Teflon coating. Saturated steam at 1 bar outside tube. Convection coefficient and mean temperature of water flowing inside tube.

**FIND:** Condensation convection coefficient. Steam condensation rate per unit length. Comparison with condensation rate for uncoated brass tube.

**SCHEMATIC:**

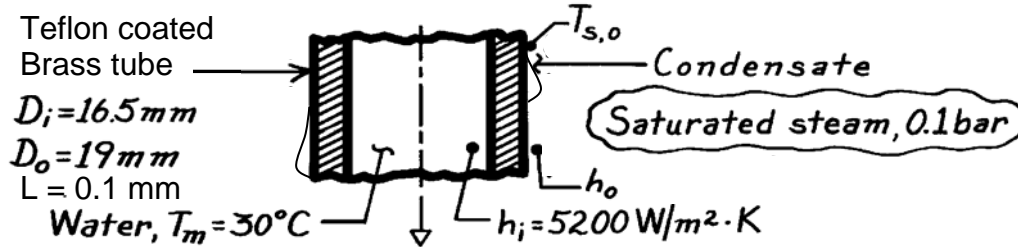

**ASSUMPTIONS:** (1) Dropwise condensation, (2) Correlations for a copper surface can be applied to Teflon, and (3) Negligible effect of noncondensable vapors.

**PROPERTIES:** Table A.6, Water, vapor (0.1 bar):  $T_{\text{sat}} = 318.9 \text{ K}$ ,  $h_{\text{fg}} = 2393 \times 10^3 \text{ J/kg}$ ; Table A.1, Brass ( $\bar{T} = (T_m + T_{\text{sat}})/2 \approx 300\text{K}$ ):  $k_b = 110 \text{ W/m} \cdot \text{K}$ ; Table A.3, Teflon ( $T \approx 300 \text{ K}$ ):  $k_t = 0.35 \text{ W/m} \cdot \text{K}$ .

**ANALYSIS:** The condensation rate per unit length follows from Eq. 10.34 written as

$$\dot{m}' = q' / h'_{\text{fg}} \quad (1)$$

where the heat rate per unit length follows from Eq. 10.33 using an overall heat transfer coefficient

$$q' = UP(T_{\text{sat}} - T_m) \quad (2)$$

where P is the perimeter. From Eq. 3.36, with resistances for the brass tube and Teflon coating,

$$UP = \left[ \frac{1}{h_o \pi (D_o + 2L)} + \frac{\ln[(D_o + 2L)/D_o]}{2\pi k_t} + \frac{\ln(D_o/D_i)}{2\pi k_b} + \frac{1}{h_i \pi D_i} \right]^{-1}$$

The outer heat transfer coefficient,  $h_o = \bar{h}_{\text{dc}}$ , can be calculated from Eq. 10.52,

$$\bar{h}_{\text{dc}} = 51,104 + 2044T_{\text{sat}}(^{\circ}\text{C}) = 51,104 + 2044(319.9 - 273) = 144,900 \text{ W/m}^2 \cdot \text{K}$$

Thus

$$UP = \left[ \frac{1}{144,900 \text{ W/m}^2 \cdot \text{K} \times \pi (19.2 \times 10^{-3} \text{ m})} + \frac{\ln(19.2/19)}{2\pi \times 0.35 \text{ W/m} \cdot \text{K}} \right. \\ \left. + \frac{\ln(19/16.5)}{2\pi \times 110 \text{ W/m} \cdot \text{K}} + \frac{1}{5200 \text{ W/m}^2 \cdot \text{K} \times \pi (16.5 \times 10^{-3} \text{ m})} \right]^{-1}$$

Continued...

**PROBLEM 10.70 (Cont.)**

$$UP = \left[ 1.14 \times 10^{-4} + 4.76 \times 10^{-3} + 2.04 \times 10^{-4} + 3.71 \times 10^{-3} \right]^{-1} \text{ W/m} \cdot \text{K} = 114 \text{ W/m} \cdot \text{K}.$$

Combining Eqs. (1) and (2) and substituting numerical values (see below for  $h'_{fg}$ ), find

$$\dot{m}' = UP(T_{\text{sat}} - T_m) / h'_{fg} = 114 \text{ W/m} \cdot \text{K} (318.9 - 303) \text{ K} / 2393 \times 10^3 \text{ J/kg}$$

$$\dot{m}' = 7.56 \times 10^{-4} \text{ kg/s.} \quad <$$

**COMMENTS:** (1) Since the outer convection resistance is small relative to the sum of the remaining resistances,  $T_{s,o} \approx T_{\text{sat}}$  and from Eq. 10.27,  $h'_{fg} \approx h_{fg}$ . (2) The Teflon coating induces a 21-fold increase in the condensation convection coefficient. However, the condensation rate decreases by 25 percent. This is because of the significant conduction resistance posed by the thin Teflon coating. (3) In addition to the conduction resistance, a contact resistance would exist at the Teflon-brass interface as well as constriction resistances at the droplet-Teflon interfaces, further reducing the condensation rate.

## PROBLEM 10.71

**KNOWN:** Conditions of saturated steam. Surface temperature of aluminum and stainless steel plates of known dimension.

**FIND:** (a) Temperature of the cold surface of the aluminum plate, (b) Temperature of the cold surface of the stainless steel plate.

**SCHEMATIC:**

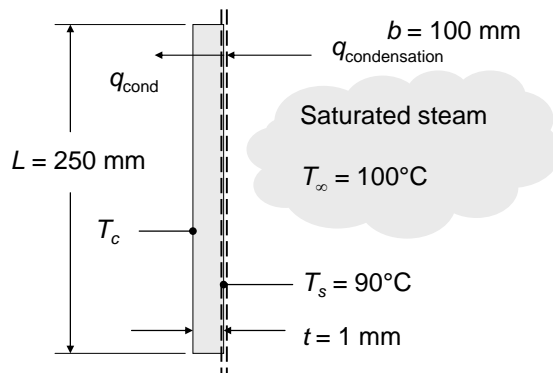

**ASSUMPTIONS:** (1) Dropwise condensation on stainless steel described by Equation 10.52, (2) Filmwise condensation on aluminum, (3) Constant properties, (4) Steady state.

**PROPERTIES:** Table A.6, Water vapor ( $T_\infty = 100^\circ\text{C} = 373 \text{ K}$ ):  $p_{\text{A,sat}} = 1.008 \text{ bar}$ ,  $h_{fg} = 2.257 \times 10^6 \text{ J/kg}$ ; Table A.6, Water, liquid ( $T_f = (T_s + T_{\text{sat}})/2 = 95^\circ\text{C} = 368 \text{ K}$ ):  $c_{p,l} = 4212 \text{ J/kg}\cdot\text{K}$ ,  $\mu_l = 0.0002958 \text{ N}\cdot\text{s/m}^2$ ,  $k_l = 0.6782 \text{ W/m}\cdot\text{K}$ ,  $\nu_l = 3.076 \times 10^{-7} \text{ m}^2/\text{s}$ ; Table A.1, Aluminum 2024-T6 ( $T = 300 \text{ K}$ ):  $k_{\text{Al}} = 177 \text{ W/m}\cdot\text{K}$ ; Table A.1 A302 Stainless Steel ( $T = 300 \text{ K}$ ):  $k_{\text{SS}} = 15.1 \text{ W/m}\cdot\text{K}$ .

**ANALYSIS:** An energy balance for the control surface at  $T_s$  yields

$$q = \bar{h}bL(T_{\text{sat}} - T_s) = \frac{k_m bL}{t}(T_s - T_c) \quad (1)$$

where  $k_m$  is the thermal conductivity of the metal plate. Equation (1) may be rearranged to yield

$$T_c = T_s - \frac{t\bar{h}}{k_m}(T_{\text{sat}} - T_s) \quad (2)$$

(a) For filmwise condensation on the aluminum plate,  $Ja = c_{p,l}(T_{\text{sat}} - T_s)/h_{fg} = 4212 \text{ J/kg}\cdot\text{K}(100 - 90)\text{K}/2.257 \times 10^6 \text{ J/kg} = 0.0187$ . The modified latent heat is  $h'_{fg} = h_{fg}(1 + 0.68Ja) = 2.257 \times 10^6 \text{ J/kg} \times (1 + 0.68 \times 0.0187) = 2.286 \times 10^6 \text{ J/kg}$ . Evaluation of Equation 10.42 yields

$$P = \frac{k_l L (T_{\text{sat}} - T_s)}{\mu_l h'_{fg} (\nu_l^2 / g)^{1/3}} = \frac{0.6782 \text{ W/m}\cdot\text{K} \times 0.25 \text{ m} \times (100 - 90)\text{K}}{0.0002958 \text{ N}\cdot\text{s/m}^2 \times 2.286 \times 10^6 \text{ J/kg} \times \left[ (3.076 \times 10^{-7} \text{ m}^2/\text{s})^2 / 9.8 \text{ m/s}^2 \right]^{1/3}} = 118$$

which is in the range of application of Equation 10.44. Therefore,

Continued...

### PROBLEM 10.71 (Cont.)

$$\begin{aligned}\bar{h}_L &= \frac{k_l}{(v_l^2/g)^{1/3}} \frac{1}{P} (0.68P + 0.89)^{0.82} \\ &= \frac{0.6782 \text{ W/m} \cdot \text{K}}{\left[ (3.076 \times 10^{-7} \text{ m}^2/\text{s})^2 / 9.8 \text{ m}^2/\text{s} \right]^{1/3}} \frac{1}{118} (0.68 \times 118 + 0.89)^{0.82} = 9930 \text{ W/m}^2 \cdot \text{K}\end{aligned}$$

From Equation (2), the cold surface temperature is

$$T_{c,AL} = 90^\circ\text{C} - \frac{0.001 \text{ m} \times 9930 \text{ W/m}^2 \cdot \text{K}}{177 \text{ W/m} \cdot \text{K}} (100 - 90) \text{ K} = 89.4^\circ\text{C} \quad <$$

(b) For dropwise condensation on the stainless steel plate, Equation 10.52 yields

$$\bar{h} = 51,104 + 2044 \times 100^\circ\text{C} = 255,500 \text{ W/m}^2 \cdot \text{K}$$

From Equation (2), the cold surface temperature is

$$T_{c,SS} = 90^\circ\text{C} - \frac{0.001 \text{ m} \times 255,500 \text{ W/m}^2 \cdot \text{K}}{15.1 \text{ W/m} \cdot \text{K}} (100 - 90) \text{ K} = -79^\circ\text{C} \quad <$$

**COMMENTS:** (1) The required cold surface temperature associated with the stainless steel is very low, compared to the corresponding value associated with the aluminum. (2) The heat transfer rate associated with the aluminum is

$$q_{AL} = \bar{h}bL(T_{\text{sat}} - T_s) = 9930 \text{ W/m}^2 \cdot \text{K} \times 0.1 \text{ m} \times 0.25 \text{ m} \times (100 - 90) \text{ K} = 2,480 \text{ W}$$

while heat transfer rate associated with the stainless steel is

$$q_{SS} = \bar{h}bL(T_{\text{sat}} - T_s) = 255,500 \text{ W/m}^2 \cdot \text{K} \times 0.1 \text{ m} \times 0.25 \text{ m} \times (100 - 90) \text{ K} = 63,900 \text{ W}.$$

(3) For the aluminum with film condensation, the thermal resistances associated with conduction and condensation are  $R_{t,\text{cond}} = t/kA = 0.001 \text{ m} / (177 \text{ W/m} \cdot \text{K} \times 0.25 \text{ m} \times 0.1 \text{ m}) = 225 \times 10^{-6} \text{ K/W}$  and

$$R_{t,\text{conv}} = 1/\bar{h}bL = 1/\left[ 9930 \text{ W/m}^2 \cdot \text{K} \times 0.25 \text{ m} \times 0.1 \text{ m} \right] = 4030 \times 10^{-6} \text{ K/W} \text{ respectively. Hence, if}$$

dropwise condensation could be promoted on the aluminum plate, the overall thermal resistance would decrease and the heat transfer rate would increase. (4) For the stainless steel with dropwise condensation, the thermal resistances associated with conduction and condensation are

$$R_{t,\text{cond}} = t/kA = 0.001 \text{ m} / (15.1 \text{ W/m} \cdot \text{K} \times 0.25 \text{ m} \times 0.1 \text{ m}) = 2650 \times 10^{-6} \text{ K/W} \text{ and}$$

$$R_{t,\text{conv}} = 1/\bar{h}bL = 1/\left[ 255,500 \text{ W/m}^2 \cdot \text{K} \times 0.25 \text{ m} \times 0.1 \text{ m} \right] = 157 \times 10^{-6} \text{ K/W} \text{ respectively. Hence, the}$$

primary resistance is associated with conduction within the metal. Further increases in the heat transfer coefficient associated with the condensation would not significantly increase the heat transfer rate. (5) Further information on the ion implantation effect on condensation is available in the following two references.

M.H. Rausch, A.P. Fröba, A. Leipertz, "Dropwise condensation heat transfer on ion implanted aluminum surfaces," *International Journal of Heat and Mass Transfer*, Vol. 51, pp. 1061 – 1070, 2008.

A. Bani Kananeh, M.H. Rausch, A.P. Fröba, A. Leipertz, "Experimental study of dropwise condensation on plasma-ion implanted stainless steel tubes," *International Journal of Heat and Mass Transfer*, Vol. 49, pp. 5018-5026, 2006.

## PROBLEM 10.72

**KNOWN:** Surface temperature and area of integrated circuits submerged in a dielectric fluid of prescribed properties. Height and temperature of condenser plates.

**FIND:** (a) Heat dissipation by an integrated circuit, (b) Condenser surface area needed to balance heat load.

**SCHEMATIC:**

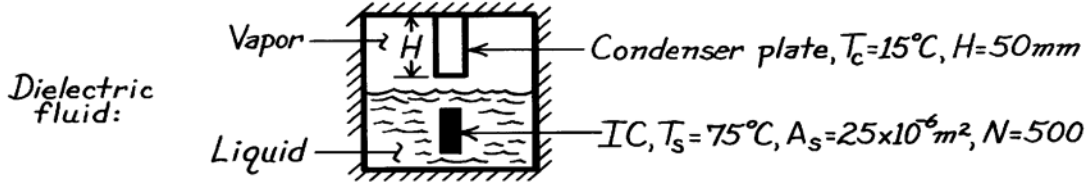

**ASSUMPTIONS:** (1) Nucleate pool boiling in liquid, (2) Laminar film condensation of vapor, (3) Negligible heat loss to surroundings.

**PROPERTIES:** Dielectric fluid (given,  $T_{\text{sat}} = 50^\circ\text{C}$ ):  $\rho_\ell = 1700\text{kg/m}^3$ ,  $c_{p,\ell} = 1005\text{J/kg}\cdot\text{K}$ ,  $\mu_\ell = 6.80 \times 10^{-4}\text{kg/s}\cdot\text{m}$ ,  $k_\ell = 0.062\text{W/m}\cdot\text{K}$ ,  $\text{Pr}_\ell = 11$ ,  $\sigma = 0.013\text{kg/s}^2$ ,  $h_{\text{fg}} = 1.05 \times 10^5\text{J/kg}$ ,  $C_{s,f} = 0.004$ ,  $n = 1.7$ ,  $\nu_\ell = \mu_\ell / \rho_\ell = 4.0 \times 10^{-7}\text{m}^2/\text{s}$ .

**ANALYSIS:** (a) For nucleate pool boiling,

$$q_s'' = \mu_\ell h_{\text{fg}} \left[ \frac{g(\rho_\ell - \rho_v)}{\sigma} \right]^{1/2} \left( \frac{c_{p,\ell} \Delta T_e}{C_{s,f} h_{\text{fg}} \text{Pr}_\ell^n} \right)^3 \approx 6.8 \times 10^{-4}\text{kg/s}\cdot\text{m} \left( 1.05 \times 10^5\text{J/kg} \right)$$

$$\times \left[ \frac{9.8\text{m/s}^2 \times 1700\text{kg/m}^3}{0.013\text{kg/s}^2} \right]^{1/2} \left( \frac{1005\text{J/kg}\cdot\text{K} \times 25\text{K}}{0.004 \times 1.05 \times 10^5\text{J/kg} \times 11^{1.7}} \right)^3 = 84,530\text{W/m}^2$$

$$q_s = A_s q_s'' = 84,530\text{W/m}^2 \times 25 \times 10^{-6}\text{m}^2 = 2.11\text{W} \quad <$$

(b) From Eq. 10.42,

$$P = \frac{k_\ell L (T_{\text{sat}} - T_s)}{\mu_\ell h'_{\text{fg}} (\nu_\ell^2 / g)^{1/3}}$$

$$= \frac{0.062\text{W/m}\cdot\text{K} \times 0.05\text{m} (50 - 15)\text{K}}{6.80 \times 10^{-4}\text{kg/s}\cdot\text{m} \times 1.29 \times 10^5\text{J/kg} \times \left[ (4.0 \times 10^{-7}\text{m}^2/\text{s})^2 / 9.8\text{m/s}^2 \right]^{1/3}} = 48.8$$

where  $h'_{\text{fg}} = h_{\text{fg}} + 0.68c_{p,\ell}(T_{\text{sat}} - T_s) = 1.29 \times 10^5\text{J/kg}$ . With  $15.8 < P < 2530$ , the flow is wavy laminar and Eq. 10.44 gives

$$\bar{h}_L = \frac{k_\ell}{(\nu_\ell^2 / g)^{1/3}} \frac{1}{P} (0.68P + 0.89)^{0.82}$$

$$= \frac{0.062\text{W/m}\cdot\text{K}}{\left[ (4.0 \times 10^{-7}\text{m}^2/\text{s})^2 / 9.8\text{m}^2/\text{s} \right]^{1/3}} \frac{1}{48.8} (0.68 \times 48.8 + 0.89)^{0.82} = 904\text{W/m}^2 \cdot \text{K}$$

To balance the heat load,  $q_c = Nq_s$ , thus from Eq. 10.33,

$$\bar{h}_L A_c (T_{\text{sat}} - T_c) = Nq_s = 500 \times 2.11\text{W} = 1055\text{W}$$

$$A_c = \frac{1055\text{W}}{904\text{W/m}^2 \cdot \text{K} \times (50 - 15)^\circ\text{C}} = 0.033\text{m}^2 \quad <$$

### PROBLEM 10.73

**KNOWN:** Thin-walled thermosyphon. Absorbs heat by boiling saturated water at atmospheric pressure on boiling section  $L_b$ . Rejects heat by condensing vapor into a thick film which falls length of condensation section  $L_c$  back into boiling section.

**FIND:** (a) Mean surface temperature,  $T_{s,b}$ , of the boiling surface if nucleate boiling flux is 30% critical flux, (b) Mean surface temperature,  $T_{s,c}$  of condensation section, and total condensation flow rate,  $\dot{m}$ , in thermosyphon.

**SCHEMATIC:**

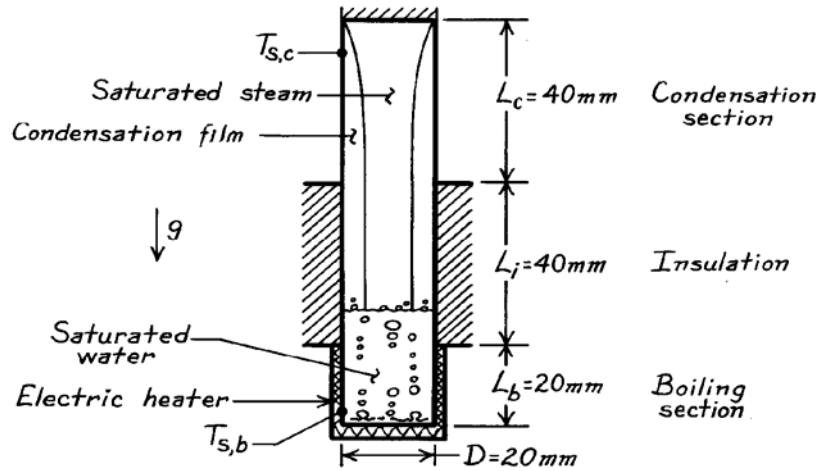

**ASSUMPTIONS:** (1) Film condensation occurs in condensation section which approximates a vertical plate, (2) Boiling and condensing section are separated by insulated length  $L_i$ , (3) Top surface of condensation section is insulated, (4) For condensation, liquid properties evaluated at  $T_f = 90^\circ\text{C}$ .

**PROPERTIES:** Table A-6, Saturated water ( $100^\circ\text{C}$ ):  $\rho_\ell = 1/v_f = 957.9 \text{ kg/m}^3$ ,  $c_{p,\ell} = 4217 \text{ J/kg}\cdot\text{K}$ ,  $\mu_\ell = 279 \times 10^{-6} \text{ N}\cdot\text{s/m}^2$ ,  $\text{Pr}_\ell = 1.76$ ,  $h_{fg} = 2257 \text{ kJ/kg}$ ,  $\sigma = 58.9 \times 10^{-3} \text{ N/m}$ ; Saturated vapor ( $100^\circ\text{C}$ ):  $\rho_v = 1/v_g = 0.5955 \text{ kg/m}^3$ ; Saturated water ( $90^\circ\text{C}$ ):  $\rho_\ell = 1/v_f = 964.9 \text{ kg/m}^3$ ,  $c_{p,\ell} = 4207 \text{ J/kg}\cdot\text{K}$ ,  $\mu_\ell = 313 \times 10^{-6} \text{ N}\cdot\text{s/m}^2$ ,  $k_\ell = 0.676 \text{ W/m}\cdot\text{K}$ ,  $\nu_\ell = \mu_\ell/\rho_\ell = 3.24 \times 10^{-7} \text{ m}^2/\text{s}$ .

**ANALYSIS:** (a) The heat flux for the boiling section is 30% of the critical heat flux which at atmospheric pressure is

$$q''_{s,b} = 0.30q''_{\max} = 0.30 \times 1.26 \times 10^6 \text{ W/m}^2 = 3.78 \times 10^5 \text{ W/m}^2.$$

Using the Rohsenow correlation for nucleate boiling with  $T_{\text{sat}} = 100^\circ\text{C}$  and typical values for the surface of  $C_{s,f} = 0.0130$  and  $n = 1.0$ , find

$$q''_{s,b} = \mu_\ell h_{fg} \left[ \frac{g(\rho_\ell - \rho_v)}{\sigma} \right]^{1/2} \left( \frac{c_{p,\ell} (T_{s,b} - T_{\text{sat}})}{C_{s,f} h_{fg} \text{Pr}_\ell^n} \right)^3$$

$$3.78 \times 10^5 \text{ W/m}^2 = 279 \times 10^{-6} \text{ N}\cdot\text{s/m}^2 \times 2257 \times 10^3 \text{ J/kg} \times$$

$$\left[ \frac{9.8 \text{ m/s}^2 (957.9 - 0.5955) \text{ kg/m}^3}{58.9 \times 10^{-3} \text{ N/m}} \right]^{1/2} \left( \frac{4217 \text{ J/kg}\cdot\text{K} (T_{s,b} - 100)}{0.013 \times 2257 \times 10^3 \text{ J/kg} \cdot 1.76^{1.0}} \right)^3$$

Continued ...

**PROBLEM 10.73 (Cont.)**

$$T_{s,b} = 114.0^\circ\text{C} \quad <$$

(b) The heat transferred into the boiling section must be rejected by film condensation,

$$q_c = q_b = q''_{s,b} \left[ \pi D^2 / 4 + \pi DL_b \right]$$

$$q_c = 3.78 \times 10^5 \text{ W/m}^2 \left[ \pi (0.020 \text{ m})^2 / 4 + \pi (0.020 \text{ m}) \times 0.020 \text{ m} \right] = 594 \text{ W}.$$

Thus from Eq. 10.34,  $\dot{m} = q_c / h'_{fg}$  and from Eq. 10.36,  $Re_\delta = 4\dot{m} / \mu_\ell b = 4q_c / h'_{fg} \mu_\ell \pi D$ , where  $h'_{fg} = h_{fg} + 0.68c_{p,\ell}(T_{sat} - T_{s,c})$ . We approximate  $h'_{fg} = h_{fg}$  and find  $Re_\delta \approx 53.5$ . Thus the flow is wavy laminar. From Eq. 10.39 we have

$$\begin{aligned} \bar{h}_L &= \frac{k_\ell}{(v_\ell^2/g)^{1/3}} \frac{Re_\delta}{1.08Re_\delta^{1.22} - 5.2} = \\ &= \frac{0.676 \text{ W/m} \cdot \text{K}}{\left[ (3.24 \times 10^{-7} \text{ m}^2/\text{s})^2 / 9.8 \text{ m}^2/\text{s} \right]^{1/3}} \frac{53.5}{1.08 \times 53.5^{1.22} - 5.2} = 12,290 \text{ W/m}^2 \cdot \text{K} \end{aligned} \quad (1)$$

From Eq. 10.33 we can solve for  $T_{sat} - T_{s,c}$ , as

$$T_{sat} - T_{s,c} = q_c / \bar{h}_L \pi DL = 594 \text{ W} / (12,290 \text{ W/m}^2 \cdot \text{K} \times \pi \times 0.02 \text{ m} \times 0.04 \text{ m}) = 19.2^\circ\text{C} \quad (2)$$

This solution can now be iterated by recalculating  $h'_{fg}$  and  $Re_\delta$  and re-solving Eqs. (1) and (2). The iterations converge to  $T_{sat} - T_{s,c} = 19.1^\circ\text{C}$ . Thus

$$T_{s,c} = 80.9^\circ\text{C} \quad <$$

Finally, with  $h'_{fg} = 2.31 \times 10^6 \text{ J/kg}$ ,

$$\dot{m} = q_c / h'_{fg} = 594 \text{ W} / 2.31 \times 10^6 \text{ J/kg} = 2.6 \times 10^{-4} \text{ kg/s} \quad <$$

## PROBLEM 10.74

**KNOWN:** Thermosyphon configuration for cooling a computer chip of prescribed size.

**FIND:** (a) Chip temperature and total power dissipation when chip operates at 90% of critical heat flux, (b) Required condenser length.

**SCHEMATIC:**

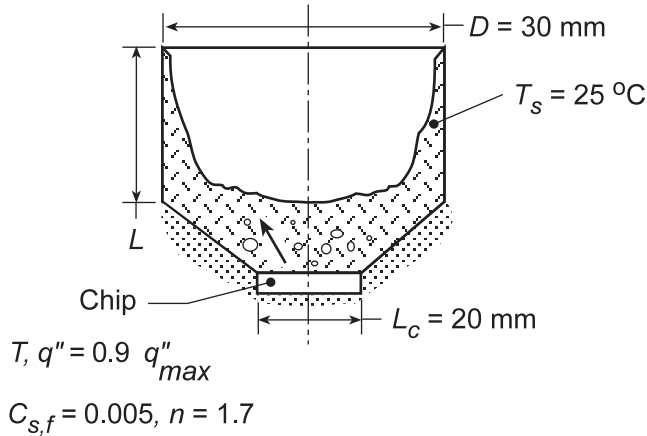

**ASSUMPTIONS:** (1) Steady-state, (2) Saturated liquid/vapor conditions, (3) Negligible heat transfer from bottom of chip.

**PROPERTIES:** Fluorocarbon (prescribed):  $T_{sat} = 57^\circ\text{C}$ ,  $c_{p,l} = 1100 \text{ J/kg}\cdot\text{K}$ ,  $h_{fg} = 84,400 \text{ J/kg}$ ,  $\rho_l = 1619.2 \text{ kg/m}^3$ ,  $\rho_v = 13.4 \text{ kg/m}^3$ ,  $\sigma = 8.1 \times 10^{-3} \text{ kg/s}^2$ ,  $\mu_l = 440 \times 10^{-6} \text{ kg/m}\cdot\text{s}$ ,  $\text{Pr}_l = 9.01$ ,  $k_l = 0.054 \text{ W/m}\cdot\text{K}$ ,  $\nu_l = \mu_l / \rho_l = 0.272 \times 10^{-6} \text{ m}^2/\text{s}$ .

**ANALYSIS:** (a) With  $q'' = 0.9 q''_{max}$  and the critical heat flux given by Eq. 10.6 with  $C=0.149$ , the chip power dissipation is

$$q = 0.9 L_c^2 \times 0.149 h_{fg} \rho_v \left[ \frac{\sigma g (\rho_l - \rho_v)}{\rho_v^2} \right]^{1/4}$$

$$q = 0.9 (0.02 \text{ m})^2 \times 0.149 (84,400 \text{ J/kg}) 13.4 \text{ kg/m}^3 \left[ \frac{0.0081 \text{ kg/s}^2 (9.8 \text{ m/s}^2) (1605.8 \text{ kg/m}^3)}{(13.4 \text{ kg/m}^3)^2} \right]^{1/4}$$

$$q_c = 0.9 (4 \times 10^{-4} \text{ m}^2) 1.55 \times 10^5 \text{ W/m}^2 = 55.7 \text{ W} \quad <$$

With operation at  $q'' = 1.40 \times 10^5 \text{ W/m}^2$  in the nucleate boiling region, Eq. 10.5 yields

$$T = T_{sat} + \frac{C_{s,f} h_{fg} \text{Pr}_l^n}{c_{p,l}} \left( \frac{q''}{\mu_l h_{fg}} \right)^{1/3} \left[ \frac{\sigma}{g (\rho_l - \rho_v)} \right]^{1/6}$$

$$T = 57^\circ\text{C} + \frac{0.005 (84,400 \text{ J/kg}) (9.01)^{1.7}}{1100 \text{ J/kg}\cdot\text{K}} \left( \frac{1.40 \times 10^5 \text{ W/m}^2}{4.4 \times 10^{-4} \text{ kg/m}\cdot\text{s} \times 84,400 \text{ J/kg}} \right)^{1/3} \left[ \frac{0.0081 \text{ kg/s}^2}{9.8 \text{ m/s}^2 (1605.8 \text{ kg/m}^3)} \right]^{1/6}$$

Continued...



**PROBLEM 10.74 (Cont.)**

$$T = 57^\circ\text{C} + 22.4^\circ\text{C} = 79.4^\circ\text{C}$$

&lt;

(b) The power dissipated by the chip must be balanced by the rate of heat transfer from the condensing section. We combine Eqs. 10.34 and 10.36 to obtain  $\text{Re}_\delta = 4q/\mu_\ell b h'_{fg}$ , where  $b = \pi D = 0.0942\text{ m}$  and  $h'_{fg} = h_{fg} + 0.68c_{p,1}(T_{\text{sat}} - T_s) = 84,400\text{ J/kg} + 0.68(1100\text{ J/kg}\cdot\text{K})32^\circ\text{C} = 108,300\text{ J/kg}$ . Hence,  $\text{Re}_\delta = 4(55.7\text{ W})/4.4 \times 10^{-4}\text{ kg/m}\cdot\text{s}(0.0942\text{ m})108,300\text{ J/kg} = 49.6$  and the condensate film is in the laminar-wavy region. Hence, from Eq. 10.39

$$\begin{aligned} \bar{h}_L &= \frac{k_\ell}{(v_\ell^2/g)^{1/3}} \frac{\text{Re}_\delta}{1.08\text{Re}_\delta^{1.22} - 5.2} = \\ &= \frac{0.054\text{ W/m}\cdot\text{K}}{\left[(0.272 \times 10^{-6}\text{ m}^2/\text{s})^2 / 9.8\text{ m}^2/\text{s}\right]^{1/3}} \frac{49.6}{1.08 \times 49.6^{1.22} - 5.2} = 1130\text{ W/m}^2 \cdot \text{K} \end{aligned}$$

and from Eq. 10.33,

$$L = \frac{q_c}{\bar{h}_L \pi D (T_{\text{sat}} - T_s)} = \frac{55.7\text{ W}}{1130\text{ W/m}^2 \cdot \text{K} \times 0.0942\text{ m} \times 32^\circ\text{C}} = 16.4\text{ mm}$$

&lt;

**COMMENTS:** The chip operating temperature ( $T = 79.4^\circ\text{C}$ ) is not excessive, and the proposed scheme provides a compact means of cooling high performance chips.

## PROBLEM 10.75

**KNOWN:** Copper plate,  $2\text{ m} \times 2\text{ m}$ , in a condenser-boiler section maintained at  $T_s = 100^\circ\text{C}$  separates condensing saturated steam and nucleate-pool boiling of saturated liquid X.

**FIND:** (a) Rates of evaporation and condensation (kg/s) for the two fluids and (b) Saturation temperature  $T_{\text{sat}}$  and pressure  $p$  for the steam, assuming that film condensation occurs.

**SCHEMATIC:**

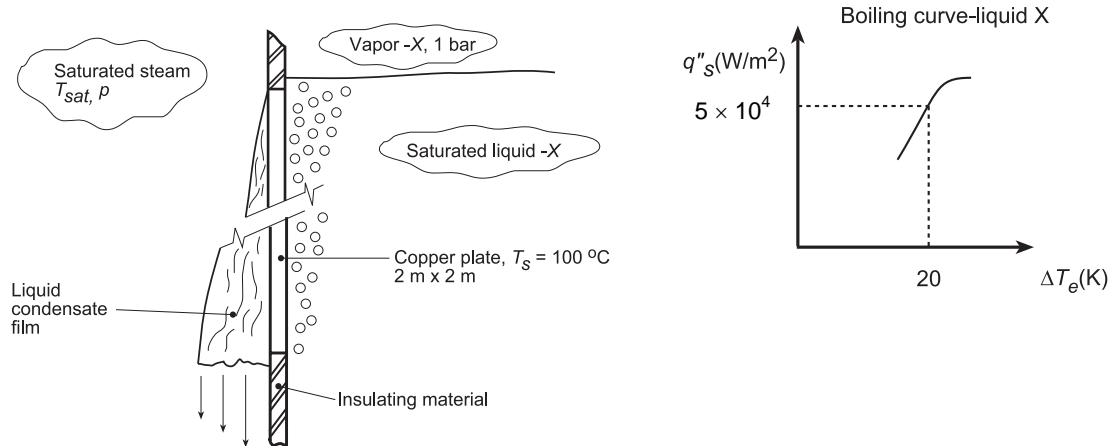

**ASSUMPTIONS:** (1) Steady-state conditions, (2) Isothermal copper plate.

**PROPERTIES:** *Fluid-X* (Given, 1 atm):  $T_{\text{sat}} = 80^\circ\text{C}$ ,  $h_{\text{fg}} = 700\text{ kJ/kg}$ , portion of boiling curve shown above for operating condition,  $\Delta T_e = T_s - T_{\text{sat}} = (100 - 80)^\circ\text{C} = 20^\circ\text{C}$ ,  $q_s'' = 5 \times 10^4\text{ W/m}^2$ ; *Table A.6*, Water (saturated,  $T_f \approx 100^\circ\text{C}$ ):  $\rho_\ell = 957.9\text{ kg/m}^3$ ,  $h_{\text{fg}} = 2257\text{ kJ/kg}$ ,  $c_{p,\ell} = 4217\text{ J/kg}$ ,  $\mu_\ell = 279 \times 10^{-6}\text{ N}\cdot\text{s/m}^2$ ,  $k_\ell = 0.680\text{ W/m}\cdot\text{K}$ ,  $\text{Pr}_\ell = 1.76$ ,  $\nu_\ell = \mu_\ell / \rho_\ell = 2.91 \times 10^{-7}\text{ m}^2/\text{s}$ .

**ANALYSIS:** (a) For fluid-X, with  $\Delta T_e = T_s - T_{\text{sat}} = (100 - 80)^\circ\text{C} = 20\text{ K}$ , the heat flux from the boiling curve is

$$q_s'' = 50,000\text{ W/m}^2$$

and the heat rate from the copper plate section into liquid-X is

$$q_s = q_s'' \times A_s = 50,000\text{ W/m}^2 \times (2 \times 2)\text{ m}^2 = 200,000\text{ W}$$

From an energy balance around liquid-X, the evaporation rate for fluid-X is

$$\dot{m}_X = q_s / h_{\text{fg},X} = 200,000\text{ W} / 700,000\text{ J/kg} = 0.286\text{ kg/s} \quad <$$

The heat rate into the copper plate section from the steam is  $q_s = 200,000\text{ W}$ , and from an energy balance around the condensate film, the condensation rate for steam (w)

$$\dot{m}_w = q_s / h'_{\text{fg},w} = 200,000\text{ W} / 2.257 \times 10^6\text{ J/kg} = 0.0886\text{ kg/s}$$

where we are assuming that  $T_{\text{sat},w}$  is only a few degrees above  $T_s$  so that  $h'_{\text{fg}} \approx h_{\text{fg}}$ .

(b) With  $T_{\text{sat}}$  unknown, we begin by evaluating the liquid water properties at  $100^\circ\text{C}$  as given above. Then from Eq. 10.36,

$$\text{Re}_\delta = 4\dot{m}_w / \mu_\ell b = 4 \times 0.0886\text{ kg/s} / 279 \times 10^{-6}\text{ N}\cdot\text{s/m}^2 \times 2\text{ m} = 635$$

Continued...

### PROBLEM 10.75 (Cont.)

Thus the flow is wavy laminar. From Eq. 10.39 we have

$$\begin{aligned}\bar{h}_L &= \frac{k_\ell}{(v_\ell^2/g)^{1/3}} \frac{\text{Re}_\delta}{1.08\text{Re}_\delta^{1.22} - 5.2} = \\ &= \frac{0.680 \text{ W/m}\cdot\text{K}}{\left[ (2.91 \times 10^{-7} \text{ m}^2/\text{s})^2 / 9.8 \text{ m}^2/\text{s} \right]^{1/3}} \frac{635}{1.08 \times 635^{1.22} - 5.2} = 7430 \text{ W/m}^2 \cdot \text{K}\end{aligned}$$

From Eq. 10.33 we can solve for  $T_{\text{sat}} - T_{\text{s,c}}$ , as

$$T_{\text{sat}} - T_{\text{s,c}} = q_c / \bar{h}_L A = 200,000 \text{ W} / (7430 \text{ W/m}^2 \cdot \text{K} \times 4 \text{ m}^2) = 6.7^\circ\text{C}$$

Thus

$$T_{\text{sat}} = 106.7^\circ\text{C} = 379.7 \text{ K} \quad <$$

$$\text{From Table A.6, } p = p_{\text{sat}}(379.7 \text{ K}) = 1.27 \text{ bars} \quad <$$

**COMMENTS:** The calculation could be repeated with properties evaluated at  $T_f = 103^\circ\text{C}$  and with  $h'_{fg} \neq h_{fg}$ , but the results would not change much.

### PROBLEM 10.76

**KNOWN:** Thin-walled container filled with a low boiling point liquid (A) at  $T_{\text{sat},A}$ . Outer surface of container experiences laminar-film condensation with the vapor of a high-boiling point fluid (B). Laminar film extends from the location of the liquid-A free surface. The heat flux for nucleate pool boiling in liquid-A along the container wall is given as  $q''_{\text{npb}} = C(T_s - T_{\text{sat}})^3$ , where  $C$  is a known empirical constant.

**FIND:** (a) Expression for the average temperature of the container wall,  $T_s$ ; assume that the properties of fluids A and B are known; (b) Heat rate supplied to liquid-A, and (c) Time required to evaporate all the liquid-A in the container, assuming that initially the container is filled,  $y = L$ .

**SCHEMATIC:**

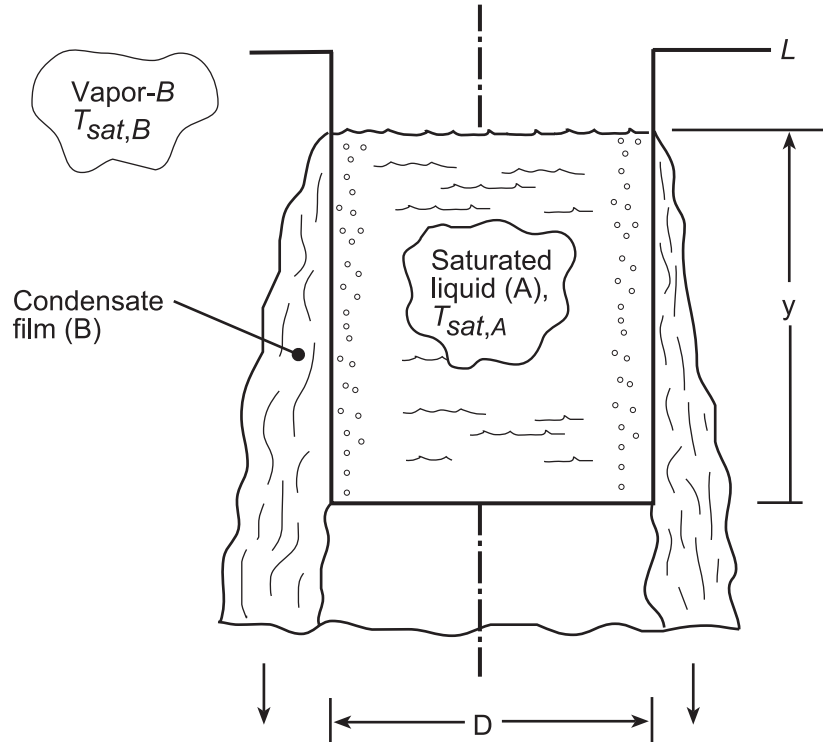

**ASSUMPTIONS:** (1) Nucleate pool boiling occurs on the inner surface of the container with liquid-A, (2) Laminar film condensation occurs on the outer surface of the container with fluid-B over the liquid-A free surface,  $y$ , and (3) Negligible wall thermal resistance.

**ANALYSIS:** (a) Perform an energy balance on the control surface about the container wall along locations experiencing boiling (A) and condensation (B) as shown in the schematic above.

$$\dot{E}''_{\text{in}} - \dot{E}''_{\text{out}} = 0 \quad (1)$$

$$q''_{\text{cond}} - q''_{\text{npb}} = 0 \quad (2)$$

$$\bar{h}_y (\pi D y) (T_{\text{sat},B} - T_s) - (\pi D y) C (T_s^3 - T_{\text{sat},A}^3) = 0$$

$$\bar{h}_y (T_{\text{sat},B} - T_s) = C (T_s - T_{\text{sat},A})^3 \quad (3) <$$

where  $\bar{h}_y$  is the average convection coefficient for laminar film condensation over the surface length 0 to  $y$ . From Eqs. 10.31 and 10.27,

Continued...

**PROBLEM 10.76 (Cont.)**

$$\bar{h}_y = 0.943 \left[ \frac{g \rho_\ell (\rho_\ell - \rho_v) k_\ell^3 h'_{fg}}{\mu_\ell (T_{sat} - T_s) y} \right]_B^{1/4} \quad (3)$$

$$h'_{fg} = h_{fg,B} + 0.68 c_{p,B} (T_{sat,B} - T_s) \quad (4)$$

where the properties are for fluid-B.

(b) The heat flux supplied to liquid-A is, from Eq. (2),  $q''_{cond} = q''_{npb}$ . Since  $\bar{h}_y$  is a function of  $y$ ,  $T_s$  and, hence, the heat fluxes will be functions of  $y$ , the height of liquid A in the container.

(c) To determine the dry-out time,  $t_f$ , begin with an energy balance on the inside of the container (fluid-A). The heat transfer supplied to liquid-A results in an evaporation rate of liquid-A,

$$q''_{npb} (\pi D y) - \frac{dM}{dt} h_{fg} = 0 \quad (4)$$

where  $M$  is the mass of liquid-A in the container,

$$M = \rho_{\ell,A} \left( \pi D^2 / 4 \right) y \quad (5)$$

Substituting Eq. (5) into (4), separating variables and identifying integration limits, find

$$C (T_s - T_{sat,A})^3 (\pi D y) = \frac{d}{dt} \left[ \rho_{\ell,A} \left( \pi D^2 / 4 \right) y \right] h_{fg}$$

$$\int_0^{t_f} dt = t_f = \frac{\rho_{\ell,A} \left( \pi D^2 / 4 \right) h_{fg}}{C \pi D} \int_L^0 \frac{dy}{(T_s - T_{sat,A})^3 y} \quad (6)$$

The definite integral could be numerically evaluated using values for  $T_s(y)$  obtained by solving Eq. (3).

### PROBLEM 10.77

**KNOWN:** Dimensions of ten thin-walled thermosyphons with boiling, insulated, and condensing sections of known lengths. Working fluid is saturated water at 0.047 bars.

**FIND:** (a) Heating rate delivered by thermosyphons if nucleate boiling heat flux is 25% of CHF and mean temperatures of boiling and condensing sections, (b) Heat loss from hot water tank to cool attic.

**SCHEMATIC:**

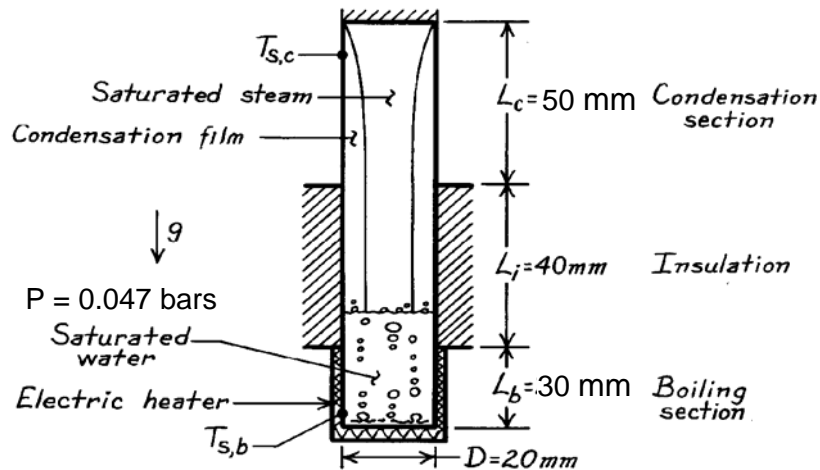

**ASSUMPTIONS:** (1) Bottom of thermosyphon can be treated as a large horizontal surface, (2) Nucleate boiling constants are typical values of  $C_{s,f} = 0.0130$  and  $n = 1.0$ , (3) Boiling and condensing section are separated by insulated length  $L_i$ , (4) Laminar film condensation occurs in condensation section which approximates a vertical plate, (5) Top surface of condensation section is insulated, (6) For condensation, liquid properties evaluated at  $T_f = 300$  K.

**PROPERTIES:** Table A-6, Saturated water ( $p = 0.047$  bars):  $T_{\text{sat}} = 305$  K,  $\rho_\ell = 1/v_f = 995$  kg/m<sup>3</sup>,  $c_{p,\ell} = 4178$  J/kg·K,  $\mu_\ell = 769 \times 10^{-6}$  N·s/m<sup>2</sup>,  $\text{Pr}_\ell = 5.20$ ,  $h_{fg} = 2426$  kJ/kg,  $\sigma = 70.9 \times 10^{-3}$  N/m; Saturated vapor ( $p = 0.047$  bars):  $\rho_v = 1/v_g = 0.0336$  kg/m<sup>3</sup>; Saturated water (300 K):  $\rho_\ell = 1/v_f = 997$  kg/m<sup>3</sup>,  $c_{p,\ell} = 4179$  J/kg·K,  $\mu_\ell = 855 \times 10^{-6}$  N·s/m<sup>2</sup>,  $\nu_\ell = \mu_\ell / \rho_\ell = 8.58 \times 10^{-7}$  m<sup>2</sup>/s,  $k_\ell = 0.613$  W/m·K.

**ANALYSIS:** (a) The heat flux for the boiling section is 25% of the critical heat flux, which is given by Eq. 10.6 with  $C = 0.149$  for a large horizontal surface,

$$q''_{s,b} = 0.25q''_{\text{max}} = (0.25)0.149h_{fg}\rho_v \left[ \frac{\sigma g(\rho_\ell - \rho_v)}{\rho_v^2} \right]^{1/4}$$

Continued ...

**PROBLEM 10.77 (Cont.)**

$$\begin{aligned}
 &= (0.25)0.149 \times 2426 \times 10^3 \text{ J/kg} \times 0.0336 \text{ kg/m}^3 \\
 &\quad \times \left[ \frac{70.9 \times 10^{-3} \text{ N/m} \times 9.8 \text{ m/s}^2 (995 - 0.0336) \text{ kg/m}^3}{(0.0336 \text{ kg/m}^3)^2} \right]^{1/4} \\
 &= 84,900 \text{ W/m}^2
 \end{aligned}$$

Using the Rohsenow correlation for nucleate boiling, find

$$\begin{aligned}
 q''_{s,b} &= \mu_\ell h_{fg} \left[ \frac{g(\rho_\ell - \rho_v)}{\sigma} \right]^{1/2} \left( \frac{c_{p,\ell} (T_{s,b} - T_{sat})}{C_{s,f} h_{fg} Pr_\ell^n} \right)^3 \\
 84,900 \text{ W/m}^2 &= 769 \times 10^{-6} \text{ N} \cdot \text{s/m}^2 \times 2426 \times 10^3 \text{ J/kg} \times
 \end{aligned}$$

$$\begin{aligned}
 &\left[ \frac{9.8 \text{ m/s}^2 (995 - 0.0336) \text{ kg/m}^3}{70.9 \times 10^{-3} \text{ N/m}} \right]^{1/2} \left( \frac{4178 \text{ J/kg} \cdot \text{K} (T_{s,b} - 305)}{0.013 \times 2426 \times 10^3 \text{ J/kg} \times 5.20^{1.0}} \right)^3 \\
 T_{s,b} &= 325 \text{ K.} &<
 \end{aligned}$$

The heat transferred into the boiling section must be rejected by film condensation,

$$\begin{aligned}
 q_c &= q_b = q''_{s,b} \left[ \pi D^2 / 4 + \pi D L_b \right] \\
 q_c &= 84,900 \text{ W/m}^2 \left[ \pi (0.020 \text{ m})^2 / 4 + \pi (0.020 \text{ m}) \times 0.030 \text{ m} \right] = 187 \text{ W.}
 \end{aligned}$$

For all ten thermosyphons, the heating rate is therefore

$$q_{tot} = 1870 \text{ W} \quad <$$

Thus from Eq. 10.34,  $\dot{m} = q_c / h'_{fg}$  and from Eq. 10.36,  $Re_\delta = 4\dot{m} / \mu_\ell b = 4q_c / h'_{fg} \mu_\ell \pi D$ , where  $h'_{fg} = h_{fg} + 0.68c_{p,\ell}(T_{sat} - T_{s,c})$ . We approximate  $h'_{fg} = h_{fg}$  and find  $Re_\delta \approx 5.7$ . Thus the flow is laminar as assumed. From Eq. 10.38 we have

$$\begin{aligned}
 \bar{h}_L &= \frac{k_\ell}{(v_\ell^2/g)^{1/3}} 1.47 Re_\delta^{-1/3} = \\
 &= \frac{0.613 \text{ W/m} \cdot \text{K}}{\left[ (8.58 \times 10^{-7} \text{ m}^2/\text{s})^2 / 9.8 \text{ m}^2/\text{s} \right]^{1/3}} 1.47 \times 5.7^{-1/3} = 11,930 \text{ W/m}^2 \cdot \text{K} \quad (1)
 \end{aligned}$$

Continued ...

### PROBLEM 10.77 (Cont.)

From Eq. 10.33 we can solve for  $T_{\text{sat}} - T_{\text{s,c}}$ , as

$$T_{\text{sat}} - T_{\text{s,c}} = q_c / \bar{h}_L \pi D L_c = 187 \text{ W} / (11,930 \text{ W/m}^2 \cdot \text{K} \times \pi \times 0.02 \text{ m} \times 0.05 \text{ m}) = 5.0^\circ\text{C} \quad (2)$$

This solution can now be iterated by recalculating  $h'_{fg}$  and  $Re_\delta$  and re-solving Eqs. (1) and (2). Subsequent iterations do not change the value of  $T_{\text{sat}} - T_{\text{s,c}}$ . Thus

$$T_{\text{s,c}} = T_{\text{sat}} - 5.0 \text{ K} = 300 \text{ K} \quad <$$

Note that  $T_f = 302.5 \text{ K}$ , which is not far from the assumed value of  $300 \text{ K}$ .

(b) There would be heat conduction through thermally-stratified water vapor in the thermosyphon tubes (neglecting tube wall conduction) which would yield a very small heat transfer rate. Hence the heat loss is approximately zero. <

**COMMENTS:** (1) The thermosyphon is a unique device in that it acts like a *thermal diode*, promoting high heat transfer rates in one direction, while serving as an effective insulator in the opposite direction. (2) The convective resistance between the boiling section and the attic air will be extremely large for an un-finned thermosyphon. Hence, it would be necessary to significantly reduce this resistance by, for example, attaching annular fins to each boiling section and using a fan to heat the fins with forced convection. (3) The operating temperatures in the boiling and condensation sections of the thermosyphon may not be optimal values. Adjustment of these temperatures can be accomplished by changing the pressure within the thermosyphon, or by using a working fluid other than water.



### PROBLEM 11.1

**KNOWN:** Initial overall heat transfer coefficient of a fire-tube boiler. Fouling factors following one year's application.

**FIND:** Whether cleaning should be scheduled.

**SCHEMATIC:**

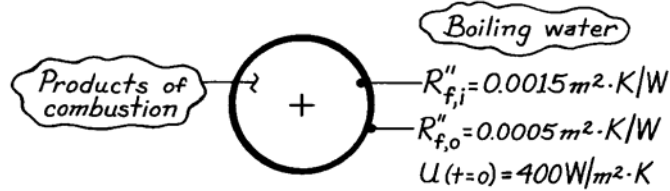

**ASSUMPTIONS:** (1) Negligible tube wall conduction resistance, (2) Negligible changes in  $h_c$  and  $h_h$ .

**ANALYSIS:** From Equation 11.1b, the overall heat transfer coefficient after one year is

$$\frac{1}{U} = \frac{1}{h_i} + \frac{1}{h_o} + R''_{f,i} + R''_{f,o}.$$

Since the first two terms on the right-hand side correspond to the reciprocal of the initial overall coefficient,

$$\frac{1}{U} = \frac{1}{400 \text{ W}/\text{m}^2 \cdot \text{K}} + (0.0015 + 0.0005) \text{ m}^2 \cdot \text{K}/\text{W} = 0.0045 \text{ m}^2 \cdot \text{K}/\text{W}$$

$$U = 222 \text{ W}/\text{m}^2 \cdot \text{K}.$$

**COMMENTS:** Periodic cleaning of the tube inner surfaces is essential to maintaining efficient fire-tube boiler operations.

## PROBLEM 11.2

**KNOWN:** Type-302 stainless tube with prescribed inner and outer diameters used in a cross-flow heat exchanger. Prescribed fouling factors and internal water flow conditions.

**FIND:** (a) Overall coefficient based upon the outer surface,  $U_o$ , with air at  $T_o = 15^\circ\text{C}$  and velocity  $V_o = 20$  m/s in cross-flow; compare thermal resistances due to convection, tube wall conduction and fouling; (b) Overall coefficient,  $U_o$ , with water (rather than air) at  $T_o = 15^\circ\text{C}$  and velocity  $V_o = 1$  m/s in cross-flow; compare thermal resistances due to convection, tube wall conduction and fouling; (c) For the water-air conditions of part (a), compute and plot  $U_o$  as a function of the air cross-flow velocity for  $5 \leq V_o \leq 30$  m/s for water mean velocities of  $u_{m,i} = 0.2, 0.5$  and  $1.0$  m/s; and (d) For the water-water conditions of part (b), compute and plot  $U_o$  as a function of the water mean velocity for  $0.5 \leq u_{m,i} \leq 2.5$  m/s for air cross-flow velocities of  $V_o = 1, 3$  and  $8$  m/s.

**SCHEMATIC:**

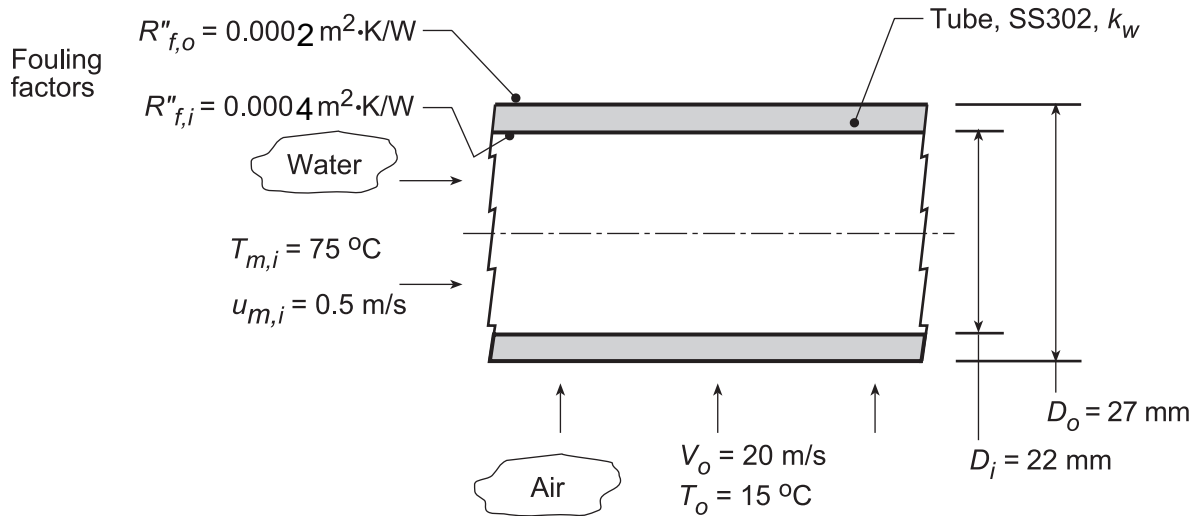

**ASSUMPTIONS:** (1) Steady-state conditions, (2) Fully developed internal flow,

**PROPERTIES:** *Table A.1*, Stainless steel, AISI 302 (300 K):  $k_w = 15.1$  W/m·K; *Table A.6*, Water ( $\bar{T}_{m,i} = 348$  K):  $\rho_i = 974.8$  kg/m<sup>3</sup>,  $\mu_i = 3.746 \times 10^{-4}$  N·s/m<sup>2</sup>,  $k_i = 0.668$  W/m·K,  $Pr_i = 2.354$ ; *Table A.4*, Air (assume  $\bar{T}_{f,o} = 315$  K, 1 atm):  $k_o = 0.02737$  W/m·K,  $\nu_o = 17.35 \times 10^{-6}$  m<sup>2</sup>/s,  $Pr_o = 0.705$ .

**ANALYSIS:** (a) For the water-air condition, the overall coefficient, Eq. 11.1, based upon the outer area can be expressed as the sum of the thermal resistances due to convection (cv), tube wall conduction (w) and fouling (f):

$$1/U_o A_o = R_{\text{tot}} = R_{\text{cv},i} + R_{\text{f},i} + R_w + R_{\text{f},o} + R_{\text{cv},o}$$

$$R_{\text{cv},i} = 1/\bar{h}_i A_i \quad R_{\text{cv},o} = 1/\bar{h}_o A_o$$

$$R_{\text{f},i} = R''_{\text{f},i}/A_i \quad R_{\text{f},o} = R''_{\text{f},o}/A_o$$

and from Eq. 3.33,

$$R_w = \ln(D_o/D_i)/(2\pi L k_w)$$

The convection coefficients can be estimated from appropriate correlations.

Continued...

### PROBLEM 11.2 (Cont.)

*Estimating  $\bar{h}_i$* : For internal flow, characterize the flow evaluating thermophysical properties at  $T_{m,i}$  with

$$\text{Re}_{D,i} = \frac{u_{m,i} D_i}{\nu_i} = \frac{0.5 \text{ m/s} \times 0.022 \text{ m}}{3.746 \times 10^{-4} \text{ N} \cdot \text{s/m}^2 / 974.8 \text{ kg/m}^3} = 28,625$$

For the turbulent flow, use the Dittus-Boelter correlation, Eq. 8.60,

$$\text{Nu}_{D,i} = 0.023 \text{Re}_{D,i}^{0.8} \text{Pr}_i^{0.3}$$

$$\text{Nu}_{D,i} = 0.023(28,625)^{0.8} (2.354)^{0.3} = 109.3$$

$$\bar{h}_i = \text{Nu}_{D,i} k_i / D_i = 109.3 \times 0.668 \text{ W/m}^2 \cdot \text{K} / 0.022 \text{ m} = 3313 \text{ W/m}^2 \cdot \text{K}$$

*Estimating  $\bar{h}_o$* : For external flow, characterize the flow with

$$\text{Re}_{D,o} = \frac{V_o D_o}{\nu_o} = \frac{20 \text{ m/s} \times 0.027 \text{ m}}{17.35 \times 10^{-6} \text{ m}^2/\text{s}} = 31,124$$

evaluating thermophysical properties at  $T_{f,o} = (T_{s,o} + T_o)/2$  when the surface temperature is determined from the thermal circuit analysis result,

$$(T_{m,i} - T_o) / R_{\text{tot}} = (T_{s,o} - T_o) / R_{\text{cv},o}$$

Assume  $T_{f,o} = 315 \text{ K}$ , and check later. Using the Churchill-Bernstein correlation, Eq. 7.54, find

$$\bar{\text{Nu}}_{D,o} = 0.3 + \frac{0.62 \text{Re}_{D,o}^{1/2} \text{Pr}_o^{1/3}}{\left[1 + (0.4/\text{Pr}_o)^{2/3}\right]^{1/4}} \left[1 + \left(\frac{\text{Re}_{D,o}}{282,000}\right)^{5/8}\right]^{4/5}$$

$$\bar{\text{Nu}}_{D,o} = 0.3 + \frac{0.62(31,124)^{1/2} (0.705)^{1/3}}{\left[1 + (0.4/0.705)^{2/3}\right]^{1/4}} \left[1 + \left(\frac{31,124}{282,000}\right)^{5/8}\right]^{4/5}$$

$$\bar{\text{Nu}}_{D,o} = 102.6$$

$$\bar{h}_o = \bar{\text{Nu}}_{D,o} k_o / D_o = 102.6 \times 0.02737 \text{ W/m} \cdot \text{K} / 0.027 \text{ m} = 104.0 \text{ W/m} \cdot \text{K}$$

Using the above values for  $\bar{h}_i$ , and  $\bar{h}_o$ , and other prescribed values, the thermal resistances and overall coefficient can be evaluated and are tabulated below.

$R_{\text{cv},i}$	$R_{f,i}$	$R_w$	$R_{f,o}$	$R_{\text{cv},o}$	$U_o$	$R_{\text{tot}}$
(K/W)	(K/W)	(K/W)	(K/W)	(K/W)	(W/m <sup>2</sup> ·K)	(K/W)
0.00436	0.00578	0.00216	0.00236	0.1134	92.1	0.128

The major thermal resistance is due to outside (air) convection, accounting for 89% of the total resistance. The other thermal resistances are of similar magnitude, nearly 50 times smaller than  $R_{\text{cv},o}$ .

(b) For the water-water condition, the method of analysis follows that of part (a). For the internal flow, the estimated convection coefficient is the same as part (a). For an assumed outer film coefficient,  $\bar{T}_{f,o} = 292 \text{ K}$ , the convection correlation for the outer water flow condition  $V_o = 1 \text{ m/s}$  and  $T_o = 15^\circ\text{C}$ ,

Continued...

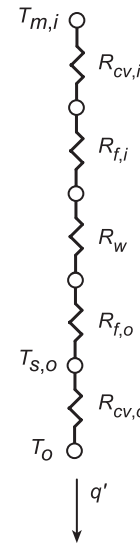

### PROBLEM 11.2 (Cont.)

find

$$Re_{D,o} = 26,260 \quad Nu_{D,o} = 220.6 \quad \bar{h}_o = 4914 \text{ W/m}^2 \cdot \text{K}$$

The thermal resistances and overall coefficient are tabulated below.

$R_{cv,i}$	$R_{f,i}$	$R_w$	$R_{f,o}$	$R_{cv,o}$	$R_{tot}$	$U_o$
(K/W)	(K/W)	(K/W)	(K/W)	(K/W)	(K/W)	(W/m <sup>2</sup> ·K)
0.00436	0.00579	0.00216	0.00236	0.00240	0.0171	691

Note that the thermal resistances are of similar magnitude. In contrast with the results for the water-air condition of part (a), the thermal resistance of the outside convection process,  $R_{cv,o}$ , is nearly 50 times smaller. The overall coefficient for the water-water condition is 7.5 times greater than that for the water-air condition.

(c) For the water-air condition, using the IHT workspace with the analysis of part (a),  $U_o$  was calculated as a function of the air cross-flow velocity for selected mean water velocities.

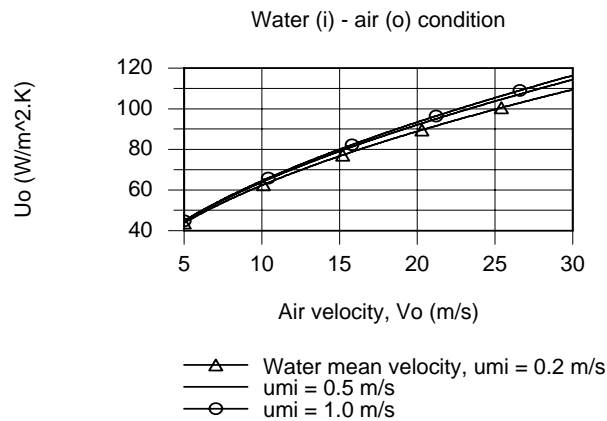

The effect of increasing the cross-flow air velocity is to increase  $U_o$  since the  $R_{cv,o}$  is the dominant thermal resistance for the system. While increasing the water mean velocity will increase  $\bar{h}_i$ , because  $R_{cv,i} \ll R_{cv,o}$ , this increase has only a small effect on  $U_o$ .

(d) For the water-water condition, using the IHT workplace with the analysis of part (b),  $U_o$  was calculated as a function of the mean water velocity for selected air cross-flow velocities.

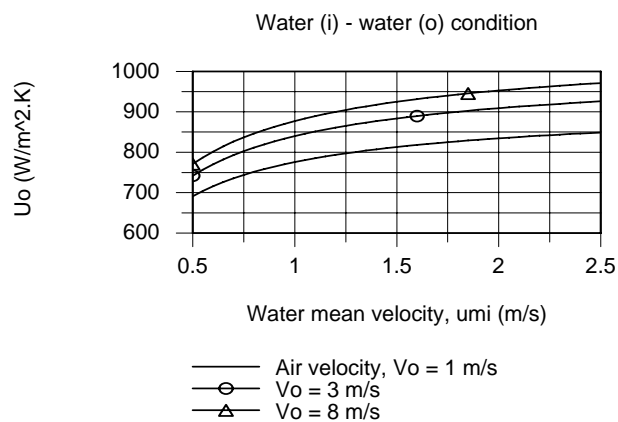

Because the thermal resistances for the convection processes,  $R_{cv,i}$  and  $R_{cv,o}$ , are of similar magnitude according to the results of part (b), we expect to see  $U_o$  significantly increase with increasing water mean velocity and air cross-flow velocity.

### PROBLEM 11.3

**KNOWN:** Inner and outer diameters of tubes in shell-and-tube heat exchanger. Inner and outer heat transfer coefficients. Properties of plastic and metal candidate wall materials.

**FIND:** (a) Ratio of surface areas for the two materials for the same heat transfer rate, (b) Ratio of masses for the two materials, (c) Which tube material would be lower cost.

**SCHEMATIC:**

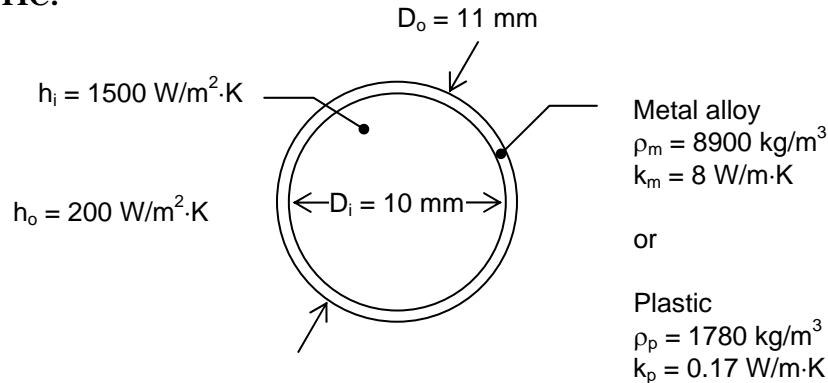

**ASSUMPTIONS:** (1) Steady-state conditions, (2) Negligible fouling.

**ANALYSIS:** (a) From Eq. 11.14, the heat transfer rates will be the same for the two wall materials when  $UA$  is the same for both. From Eq. 11.1, with no fouling or fins, and with the wall resistance given by Eq. 3.33,

$$\frac{1}{UA} = \left( \frac{1}{h_i \pi D_i} + \frac{\ln(D_o/D_i)}{2\pi k_w} + \frac{1}{h_o \pi D_o} \right) \frac{1}{L} = (R'_{\text{conv},i} + R'_w + R'_{\text{conv},o}) \frac{1}{L} \quad (1)$$

where

$$R'_{\text{conv},i} = \frac{1}{h_i \pi D_i} = \frac{1}{1500 \text{ W/m}^2 \cdot \text{K} \times \pi \times 0.01 \text{ m}} = 0.0212 \text{ m} \cdot \text{K/W}$$

$$R'_{\text{conv},o} = \frac{1}{h_o \pi D_o} = \frac{1}{200 \text{ W/m}^2 \cdot \text{K} \times \pi \times 0.011 \text{ m}} = 0.1447 \text{ m} \cdot \text{K/W}$$

and

$$R'_w = \frac{\ln(D_o/D_i)}{2\pi k_w} = \begin{cases} \frac{\ln(11/10)}{2\pi \times 8 \text{ W/m} \cdot \text{K}} = 0.0019 \text{ W/m} \cdot \text{K} & \text{metal alloy} \\ \frac{\ln(11/10)}{2\pi \times 0.17 \text{ W/m} \cdot \text{K}} = 0.0892 \text{ W/m} \cdot \text{K} & \text{plastic} \end{cases}$$

Thus, from Eq. (1),  $(UA)_m = (UA)_p$  implies the following ratio of areas,

Continued...

### PROBLEM 11.3 (Cont.)

$$\frac{A_p}{A_m} = \frac{L_p}{L_m} = \frac{R_{\text{conv},i} + R_{w,p} + R_{\text{conv},o}}{R_{\text{conv},i} + R_{w,m} + R_{\text{conv},o}}$$
$$= \frac{0.0212 \text{ m} \cdot \text{K/W} + 0.0892 \text{ m} \cdot \text{K/W} + 0.1447 \text{ m} \cdot \text{K/W}}{0.0212 \text{ m} \cdot \text{K/W} + 0.0019 \text{ m} \cdot \text{K/W} + 0.1447 \text{ m} \cdot \text{K/W}}$$

$$\frac{A_p}{A_m} = 1.52 \quad <$$

(b) The mass ratio is found as follows,

$$\frac{m_p}{m_m} = \frac{\rho_p A_p}{\rho_m A_m} = \frac{1780 \text{ kg/m}^3}{8900 \text{ kg/m}^3} 1.52 = 0.304 \quad <$$

(c) The cost ratio is

$$\frac{C_p}{C_m} = \frac{m_p}{3m_m} = \frac{1}{3} 0.304 = 0.10$$

The plastic should be specified on the basis of cost. <

**COMMENTS:** (1) Because of its lower thermal conductivity, the plastic heat exchanger wall requires 50% more surface area than the metal wall. Nonetheless, it is 70% lighter and 90% less expensive. (2) Plastic heat exchanger components must operate at temperatures below their glass transition point, which for PVDF is approximately 160°C. If the plastic heat exchanger is operated above the glass transition temperature, it will soften and lose all structural rigidity. (3) The cost-based selection of the material will change depending on the values of the inside and outside heat transfer coefficients. For example, as the inside and outside heat transfer coefficients approach infinity, the metal core should be selected on the basis of cost. For applications involving condensation or boiling, the heat transfer coefficients will depend strongly on the tube material, as discussed in Chapter 10.

## PROBLEM 11.4

**KNOWN:** Dimensions of heat exchanger tube with or without fins. Cold and hot side convection coefficients.

**FIND:** Cold side overall heat transfer coefficient without and with fins.

**SCHEMATIC:**

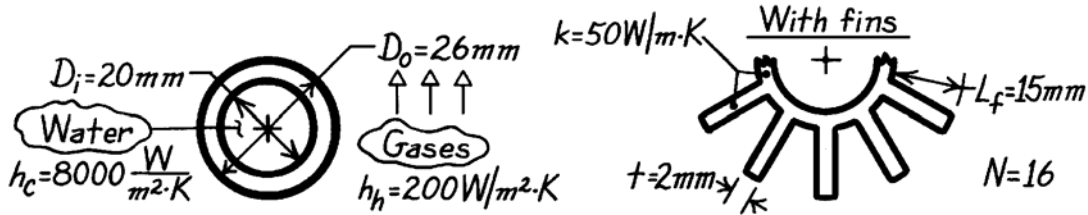

**ASSUMPTIONS:** (1) Negligible fouling, (2) Negligible contact resistance between fins and tube wall, (3)  $h_h$  is not affected by fins, (4) One-dimensional conduction in fins, (5) Adiabatic fin tip.

**ANALYSIS:** From Eq. 11.1,

$$\frac{1}{U_c} = \frac{1}{(\eta_o h)_c} + \frac{D_i \ln(D_o/D_i)}{2k} + \frac{A_c}{(\eta_o h A)_h}$$

Without fins:  $\eta_{o,c} = \eta_{o,h} = 1$

$$\frac{1}{U_c} = \frac{1}{8000 \text{ W/m}^2 \cdot \text{K}} + \frac{(0.02 \text{ m}) \ln(26/20)}{100 \text{ W/m} \cdot \text{K}} + \frac{1}{200 \text{ W/m}^2 \cdot \text{K}} \frac{20}{26}$$

$$1/U_c = (1.25 \times 10^{-4} + 5.25 \times 10^{-5} + 3.85 \times 10^{-3}) \text{ m}^2 \cdot \text{K/W} = 4.02 \times 10^{-3} \text{ m}^2 \cdot \text{K/W}$$

$$U_c = 249 \text{ W/m}^2 \cdot \text{K}. \quad <$$

With fins:  $\eta_{o,c} = 1$ ,  $\eta_{o,h} = 1 - (A_f/A)(1 - \eta_f)$  Per unit length along the tube axis,

$$A_f = N(2L_f + t) = 16(30 + 2) \text{ mm} = 512 \text{ mm}$$

$$A_h = A_f + (\pi D_o - 16t) = (512 + 81.7 - 32) \text{ mm} = 561.7 \text{ mm}$$

$$\text{With } m = (2h/kt)^{1/2} = (400 \text{ W/m}^2 \cdot \text{K} / 50 \text{ W/m} \cdot \text{K} \times 0.002 \text{ m})^{1/2} = 63.3 \text{ m}^{-1}$$

$$mL_f = (63.3 \text{ m}^{-1})(0.015 \text{ m}) = 0.95$$

and Eq. 11.4 yields

$$\eta_f = \tanh(mL_f) / mL_f = 0.739 / 0.95 = 0.778.$$

The overall surface efficiency is then

$$\eta_o = 1 - (A_f/A_h)(1 - \eta_f) = 1 - (512/561.7)(1 - 0.778) = 0.798.$$

$$\text{Hence } \frac{1}{U_c} = \left( 1.25 \times 10^{-4} + 5.25 \times 10^{-5} + \frac{\pi(20)}{0.798(200)561.7} \right) \text{ m}^2 \cdot \text{K/W} = 8.78 \times 10^{-4} \text{ m}^2 \cdot \text{K/W}$$

$$U_c = 1138 \text{ W/m}^2 \cdot \text{K}. \quad <$$

## PROBLEM 11.5

**KNOWN:** Geometry of finned, annular heat exchanger. Gas-side temperature and convection coefficient. Water-side flowrate and temperature.

**FIND:** Heat rate per unit length.

**SCHEMATIC:**

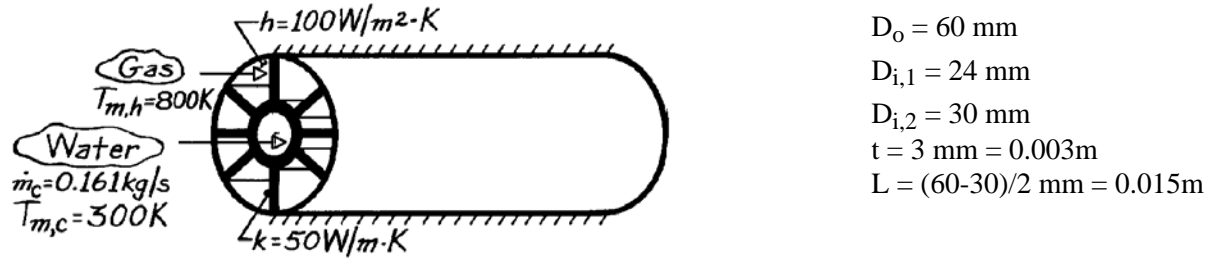

**ASSUMPTIONS:** (1) Steady-state conditions, (2) Constant properties, (3) One-dimensional conduction in strut, (4) Adiabatic outer surface conditions, (5) Negligible gas-side radiation, (6) Fully-developed internal flow, (7) Negligible fouling.

**PROPERTIES:** Table A-6, Water (300 K):  $k = 0.613 \text{ W/m}\cdot\text{K}$ ,  $\text{Pr} = 5.83$ ,  $\mu = 855 \times 10^{-6} \text{ N}\cdot\text{s/m}^2$ .

**ANALYSIS:** The heat rate is

$$q = (UA)_c (T_{m,h} - T_{m,c})$$

where

$$1/(UA)_c = 1/(hA)_c + R_w + 1/(\eta_o hA)_h$$

$$R_w = \frac{\ln(D_{i,2}/D_{i,1})}{2\pi kL} = \frac{\ln(30/24)}{2\pi(50 \text{ W/m}\cdot\text{K})\text{lm}} = 7.10 \times 10^{-4} \text{ K/W}.$$

With

$$\text{Re}_D = \frac{4\dot{m}}{\pi D_{i,1}\mu} = \frac{4 \times 0.161 \text{ kg/s}}{\pi(0.024\text{m})855 \times 10^{-6} \text{ N}\cdot\text{s/m}^2} = 9990$$

internal flow is turbulent and the Dittus-Boelter correlation gives

$$h_c = (k/D_{i,1})0.023 \text{Re}_D^{4/5} \text{Pr}^{0.4} = \left(\frac{0.613 \text{ W/m}\cdot\text{K}}{0.024\text{m}}\right)0.023(9990)^{4/5} (5.83)^{0.4} = 1883 \text{ W/m}^2 \cdot \text{K}$$

$$(hA)_c^{-1} = (1883 \text{ W/m}^2 \cdot \text{K} \times \pi \times 0.024\text{m})^{-1} = 7.043 \times 10^{-3} \text{ K/W}.$$

Find the fin efficiency as

$$\eta_o = 1 - (A_f/A)(1 - \eta_f)$$

$$A_f = 8 \times 2(L \cdot w) = 8 \times 2(0.015\text{m} \times 1\text{m}) = 0.24\text{m}^2$$

$$A = A_f + (\pi D_{i,2} - 8t)w = 0.24\text{m}^2 + (\pi \times 0.03\text{m} - 8 \times 0.003\text{m}) = 0.31\text{m}^2.$$

Continued...



### PROBLEM 11.5 (Cont.)

From Eq. 11.4,

$$\eta_f = \frac{\tanh(mL)}{mL}$$

where

$$m = [2h/kt]^{1/2} = [2 \times 100 \text{ W/m}^2 \cdot \text{K} / 50 \text{ W/m} \cdot \text{K} (0.003\text{m})]^{1/2} = 36.5 \text{ m}^{-1}$$

$$mL = (2h/kt)^{1/2} L = 36.5 \text{ m}^{-1} \times 0.015\text{m} = 0.55$$

$$\tanh\left[(2h/kt)^{1/2} L\right] = 0.499.$$

Hence

$$\eta_f = 0.499 / 0.55 = 0.911$$

$$\eta_o = 1 - (A_f / A)(1 - \eta_f) = 1 - (0.24 / 0.31)(1 - 0.911) = 0.931$$

$$(\eta_o h A)_h^{-1} = (0.931 \times 100 \text{ W/m}^2 \cdot \text{K} \times 0.31\text{m}^2)^{-1} = 0.0347 \text{ K/W}.$$

Hence

$$(UA)_c^{-1} = (7.043 \times 10^{-3} + 7.1 \times 10^{-4} + 0.0347) \text{ K/W}$$

$$(UA)_c = 23.6 \text{ W/K}$$

and

$$q = 23.6 \text{ W/K} (800 - 300) \text{ K} = 11,800 \text{ W} \quad <$$

for a 1m long section.

**COMMENTS:** (1) The gas-side resistance is substantially decreased by using the fins ( $A_f \gg \pi D_{i,2}$ ) and  $q$  is increased.

(2) Heat transfer enhancement by the fins could be increased further by using a material of larger  $k$ , but material selection would be limited by the large  $T_{m,h}$ .

## PROBLEM 11.6

**KNOWN:** Condenser arrangement of tube with six longitudinal fins ( $k = 200 \text{ W/m}\cdot\text{K}$ ). Condensing refrigerant at temperature  $45^\circ\text{C}$  flows axially through inner tube while water flows at  $0.012 \text{ kg/s}$  and  $15^\circ\text{C}$  through the six channels formed by the splines.

**FIND:** Heat removal rate per unit length of the exchanger.

**SCHEMATIC:**

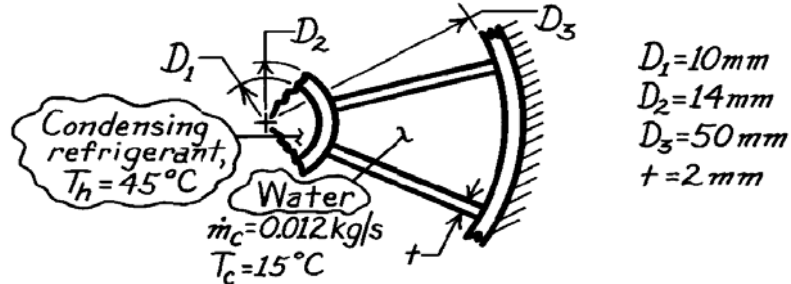

**ASSUMPTIONS:** (1) No heat loss/gain to the surroundings, (2) Water is incompressible liquid with negligible viscous dissipation, (3) Negligible thermal resistance on condensing refrigerant side,  $h_i \rightarrow \infty$ , (4) Water flow is fully developed, (5) Negligible thermal contact between splines and inner tube, (6) Heat transfer from outer tube negligible.

**PROPERTIES:** Table A-6, Water ( $\bar{T}_c = 15^\circ\text{C} = 288 \text{ K}$ ):  $\rho = 1000 \text{ kg/m}^3$ ,  $k = 0.595 \text{ W/m}\cdot\text{K}$ ,  $\nu = \mu/\rho = 1138 \times 10^{-6} \text{ N}\cdot\text{s/m}^2/1000 \text{ kg/m}^3 = 1.138 \times 10^{-6} \text{ m}^2/\text{s}$ ,  $\text{Pr} = 8.06$ ; Tube fins (given):  $k = 200 \text{ W/m}\cdot\text{K}$ .

**ANALYSIS:** Following the discussion of Section 11.2,

$$q' = UA'(T_h - T_c)$$

$$\frac{1}{UA'} = R'_h + R'_w + R'_c = R'_w + \frac{1}{(\eta_o h A')_c}$$

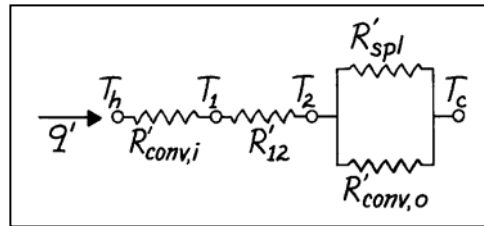

where  $R'_h = 0$ , due to the negligible thermal resistance on the refrigerant side ( $h$ ), and

$$R'_w = \frac{\ln(D_2/D_1)}{2\pi k} = \frac{\ln(14/10)}{2\pi(200 \text{ W/m}\cdot\text{K})} = 2.678 \times 10^{-4} \text{ m}\cdot\text{K/W}$$

To estimate the thermal resistance on the water side ( $c$ ), first evaluate the convection coefficient. The hydraulic diameter for a passage, where  $A_c$  is the cross-sectional area of the passage is

$$D_{h,c} = \frac{4A_c}{P} = \frac{4 \left[ \pi(D_3^2 - D_2^2)/4 - 6(D_3 - D_2)t/2 \right] / 6}{(\pi D_2 - 6t)/6 + (\pi D_3 - 6t)/6 + 2(D_3 - D_2)/2}$$

$$D_{h,c} = \frac{4 \left[ \pi(50^2 - 14^2)/4 - 6(50 - 14) \right] \times 10^{-6} \text{ m}^2 / 6}{\left[ (14\pi - 6 \times 2)/6 + (50\pi - 6 \times 2)/6 + (50 - 14) \right] \times 10^{-3} \text{ m}}$$

$$D_{h,c} = \frac{4 \times 2.656 \times 10^{-4} \text{ m}^2}{6.551 \times 10^{-2} \text{ m}} = 0.01622 \text{ m}$$

Hence the Reynolds number is

Continued ...

**PROBLEM 11.6 (Cont.)**

$$\text{Re}_{D,c} = \frac{\left[ (0.012 \text{ kg/s} / 6) / \left( 1000 \text{ kg/m}^3 \times 2.656 \times 10^{-4} \text{ m}^2 \right) \right] \times 0.01622 \text{ m}}{1.138 \times 10^{-6} \text{ m}^2/\text{s}} = 107$$

and assuming the flow is fully developed,

$$\text{Nu}_{D,c} = \frac{h_c D_{h,c}}{k} = 3.66$$

$$h_c = 3.66 \times 0.595 \text{ W/m} \cdot \text{K} / 0.01622 = 134 \text{ W/m}^2 \cdot \text{K}.$$

The temperature effectiveness of the splines (fins) on the cold side is

$$\eta_o = 1 - \frac{A_{f,c}}{A_c} (1 - \eta_f)$$

where  $A_{f,c}$  and  $A_c$  are, respectively, the finned and total (fin plus prime) surface areas, while

$$\eta_f = \frac{\tanh(mL)}{mL}$$

$$m = (2h_c / kt)^{1/2} = \left[ (2 \times 134 \text{ W/m}^2 \cdot \text{K}) / (200 \text{ W/m} \cdot \text{K} \times 0.002 \text{ m}) \right]^{1/2} = 25.88 \text{ m}^{-1}$$

$$\eta_f = \frac{\tanh(25.88 \text{ m}^{-1} \times 0.018 \text{ m})}{25.88 \text{ m}^{-1} \times 0.018 \text{ m}} = \frac{0.4348}{0.4658} = 0.934.$$

Hence

$$\eta_o = 1 - \frac{6(D_3 - D_2)}{6(D_3 - D_2) + (\pi D_2 - 6t)} [1 - \eta_f]$$

$$\eta_o = 1 - \frac{6(50 - 14)}{6(50 - 14) + (14\pi - 6 \times 2)} (1 - 0.934) = 0.943$$

$$\frac{1}{\eta_o h A'_c} = \frac{1}{0.943 \times 134 \text{ W/m}^2 \cdot \text{K} [6(50 - 14) + (14\pi - 6 \times 2)] \times 10^{-3} \text{ m}} = 3.22 \times 10^{-2} \text{ m} \cdot \text{K} / \text{W}$$

and the heat rate is

$$q' = \frac{T_h - T_c}{R'_w + 1/(\eta_o h A'_c)}$$

$$q' = \frac{(45 - 15) \text{ K}}{2.678 \times 10^{-4} \text{ m} \cdot \text{K} / \text{W} + 3.22 \times 10^{-2} \text{ m} \cdot \text{K} / \text{W}} = 924 \text{ W/m.} \quad <$$

**COMMENTS:** (1) The effective length of the fin representing the splines was conservatively estimated. The heat transfer by conduction through the splines to the outer tube and then by convection to the water was ignored.

(2) Without the splines, find  $D_h = (D_3 - D_2) = 36 \text{ mm}$  so that  $h_c = 60.5 \text{ W/m}^2 \cdot \text{K}$ . The heat rate with  $A'_c = \pi D_2$  is

$$q' = (h A'_c)(T_h - T_c) = 60.5 \text{ W/m}^2 \cdot \text{K} (0.014\pi \text{ m}) (45 - 15) \text{ K} = 79 \text{ W/m.}$$

The splines enhance the heat transfer rate by a factor of  $924/79 = 11.7$ .

## PROBLEM 11.7

**KNOWN:** Number, inner and outer diameters, and thermal conductivity of condenser tubes. Convection coefficient at outer surface. Overall flow rate, inlet temperature and properties of water flow through the tubes. Flow rate and pressure of condensing steam. Fouling factor for inner surface.

**FIND:** (a) Overall coefficient based on outer surface area,  $U_o$ , without fouling, (b) Overall coefficient with fouling, (c) Temperature of water leaving the condenser.

**SCHEMATIC:**

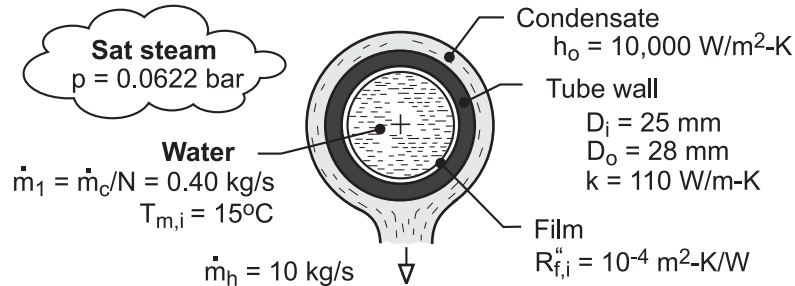

**ASSUMPTIONS:** (1) Water is incompressible with negligible viscous dissipation, (2) Fully-developed flow in tubes, (3) Negligible effect of fouling on  $D_i$ .

**PROPERTIES:** Water (Given):  $c_p = 4180 \text{ J/kg}\cdot\text{K}$ ,  $\mu = 9.6 \times 10^{-4} \text{ N}\cdot\text{s/m}^2$ ,  $k = 0.60 \text{ W/m}\cdot\text{K}$ ,  $\text{Pr} = 6.6$ .  
Table A-6, Water, saturated vapor ( $p = 0.0622 \text{ bars}$ ):  $T_{\text{sat}} = 310 \text{ K}$ ,  $h_{\text{fg}} = 2.414 \times 10^6 \text{ J/kg}$ .

**ANALYSIS:** (a) Without fouling, Eq. 11.5 yields

$$\frac{1}{U_o} = \frac{1}{h_i} \left( \frac{D_o}{D_i} \right) + \frac{D_o \ln(D_o/D_i)}{2k_t} + \frac{1}{h_o}$$

With  $\text{Re}_{D_i} = 4 \dot{m}_1 / \pi D_i \mu = 1.60 \text{ kg/s} / (\pi \times 0.025 \text{ m} \times 9.6 \times 10^{-4} \text{ N}\cdot\text{s/m}^2) = 21,220$ , flow in the tubes is turbulent, and from Eq. 8.60

$$h_i = \left( \frac{k}{D_i} \right) 0.023 \text{Re}_{D_i}^{4/5} \text{Pr}^{0.4} = \left( \frac{0.60 \text{ W/m}\cdot\text{K}}{0.025 \text{ m}} \right) 0.023 (21,200)^{4/5} (6.6)^{0.4} = 3400 \text{ W/m}^2\cdot\text{K}$$

$$U_o = \left[ \frac{1}{3400} \left( \frac{28}{25} \right) + \frac{0.028 \ln(28/25)}{2 \times 110} + \frac{1}{10,000} \right]^{-1} \text{ W/m}^2\cdot\text{K} =$$

$$\left( 3.29 \times 10^{-4} + 1.44 \times 10^{-5} + 10^{-4} \right)^{-1} \text{ W/m}^2\cdot\text{K} = 2255 \text{ W/m}^2\cdot\text{K} \quad <$$

(b) With fouling, Eq. 11.5 yields

$$U_o = \left[ 4.43 \times 10^{-4} + (D_o/D_i) R_{f,i}'' \right]^{-1} = \left( 5.55 \times 10^{-4} \right)^{-1} = 1800 \text{ W/m}^2\cdot\text{K} \quad <$$

(c) The rate at which energy is extracted from the steam equals the rate of heat transfer to the water,  $\dot{m}_h h_{\text{fg}} = \dot{m}_c c_p (T_{m,o} - T_{m,i})$ , in which case

$$T_{m,o} = T_{m,i} + \frac{\dot{m}_h h_{\text{fg}}}{\dot{m}_c c_p} = 15^\circ\text{C} + \frac{10 \text{ kg/s} \times 2.414 \times 10^6 \text{ J/kg}}{400 \text{ kg/s} \times 4180 \text{ J/kg}\cdot\text{K}} = 29.4^\circ\text{C} \quad <$$

**COMMENTS:** (1) The largest contribution to the thermal resistance is due to convection at the interior of the tube. To increase  $U_o$ ,  $h_i$  could be increased by increasing  $\dot{m}_1$ , either by increasing  $\dot{m}_c$  or decreasing  $N$ . (2) Note that  $T_{m,o} = 302.4 \text{ K} < T_{\text{sat}} = 310 \text{ K}$ , as must be the case.

## PROBLEM 11.8

**KNOWN:** Diameter and inner and outer convection coefficients of a condenser tube. Thickness, outer diameter, and pitch of aluminum fins.

**FIND:** (a) Overall heat transfer coefficient without fins, (b) Effect of fin thickness and pitch on overall heat transfer coefficient with fins.

**SCHEMATIC:**

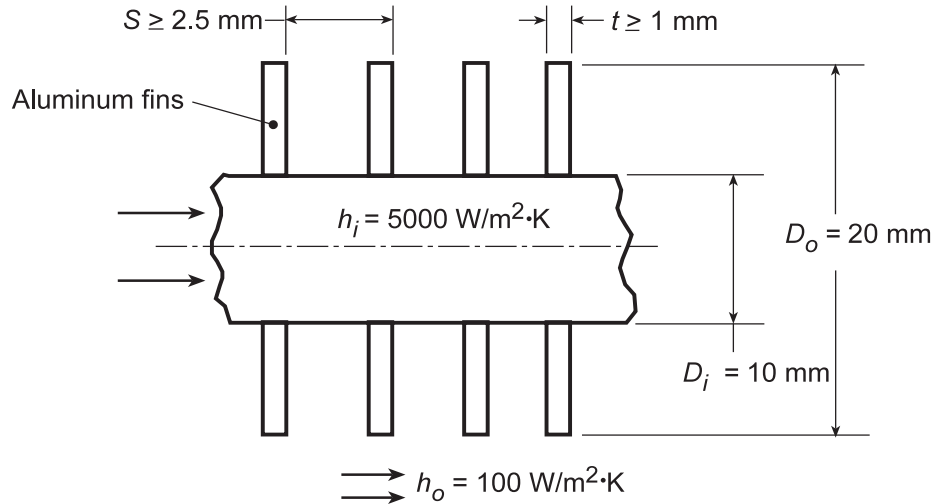

**ASSUMPTIONS:** (1) Negligible tube wall conduction resistance, (2) Negligible fouling and fin contact resistance, (3) One-dimensional conduction in fin.

**PROPERTIES:** Table A.1, Aluminum ( $T = 300$  K):  $k = 237$  W/m·K.

**ANALYSIS:** (a) With no fins, Eq. 11.1 yields

$$U = \left( h_i^{-1} + h_o^{-1} \right)^{-1} = \left( 2 \times 10^{-4} + 0.01 \right)^{-1} \text{ W/m}^2 \cdot \text{K} = 98.0 \text{ W/m}^2 \cdot \text{K} \quad <$$

(b) With fins and a unit tube length, Eqs. 11.1 and 11.3 yield

$$\frac{1}{U_i \pi D_i} = \frac{1}{h_i \pi D_i} + \frac{1}{\eta_o h_o A'_o}$$

and  $\eta_o = 1 - (A'_f/A'_o)(1 - \eta_f)$ . The total fin surface area per unit length is  $A'_f = N' 2\pi (r_{oc}^2 - r_i^2)$ , where the number of fins per unit length is  $N' = 1m/S(m)$ . The total outside surface area per unit length is  $A'_o = A'_f + (1 - N't)\pi D_i$ , and the fin efficiency is given by Eq. 3.96 or Fig. 3.20.

For  $t = 0.0015$  m and  $S = 0.0035$  m,  $r_{oc} = (D_o/2) + (t/2) = 0.01075$  m,  $N' \approx 286$ ,  $A'_f = 0.163$  m<sup>2</sup>/m, and  $A'_o = (0.163 + 0.018)$  m<sup>2</sup>/m = 0.181 m<sup>2</sup>/m. With  $r_{oc}/r_i = 2.15$ ,  $L_c = 0.00575$  m,  $A_p = 8.625 \times 10^{-6}$  m<sup>2</sup>, and  $L_c^{3/2} (h_o/kA_p)^{1/2} = 0.0964$ , Fig. 3.20 yields  $\eta_f \approx 0.99$ . Hence,  $\eta_o \approx 1 - (0.163/0.181)(0.01) = 0.99$  and

$$U_i = \left[ (1/h_i) + (\pi D_i / \eta_o h_o A'_o) \right]^{-1}$$

$$U_i = \left[ 2 \times 10^{-4} \text{ m}^2 \cdot \text{K/W} + \pi \times 0.01 \text{ m} / 0.99 \times 100 \text{ W/m}^2 \cdot \text{K} \times 0.181 \text{ m}^2/\text{m} \right]^{-1} = 512 \text{ W/m}^2 \cdot \text{K} <$$

We may use the IHT *Extended Surface Model (Performance Calculations for a Circular Rectangular Fin Array)* to consider the effect of varying  $t$  and  $S$ . To maximize  $N'$ , the minimum allowable value of

Continued...

### PROBLEM 11.8 (Cont.)

$S - t = 1.5$  mm should be selected. It is then a matter of choosing between a large number of thin fins or a smaller number of thicker fins. Calculations were performed for the following options.

$t$ (mm)	$S$ (mm)	$N'$	$U_i$ (W/m <sup>2</sup> ·K)
1	2.5	400	640
2	3.5	286	512
3	4.5	222	460
4	5.5	182	420

Since heat transfer increases with  $U_i$ , the best configuration corresponds to  $t = 1$  mm and  $S = 2.5$  mm, which provides the largest airside surface area.

**COMMENTS:** The best performance is always associated with a large number of closely spaced fins, so long as the flow between adjoining fins is sufficient to maintain the convection coefficient.

## PROBLEM 11.9

**KNOWN:** Operating conditions and surface area of a finned-tube, cross-flow exchanger.

**FIND:** Overall heat transfer coefficient.

**SCHEMATIC:**

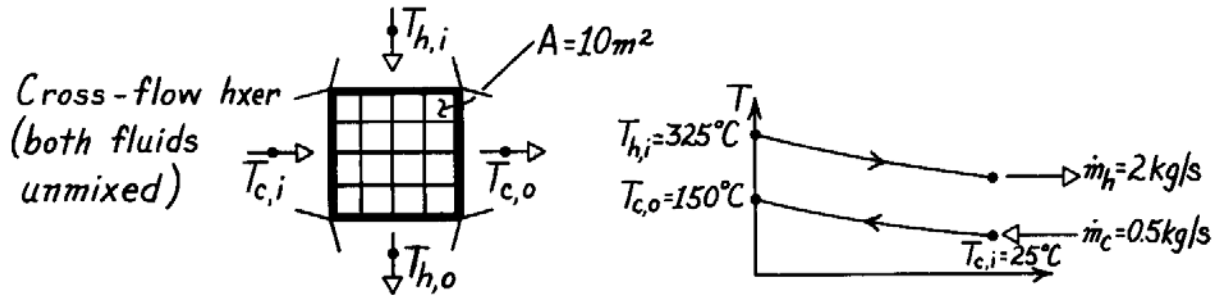

**ASSUMPTIONS:** (1) Negligible heat loss to surroundings, (2) Constant properties, (3) Exhaust gas properties are those of air.

**PROPERTIES:** Table A-6, Water ( $\bar{T}_m = 87^\circ\text{C}$ ):  $\bar{c}_p = 4203 \text{ J/kg}\cdot\text{K}$ ; Table A-4, Air ( $T_m \approx 275^\circ\text{C}$ ):  $\bar{c}_p = 1040 \text{ J/kg}\cdot\text{K}$ .

**ANALYSIS:** Since this is a cross-flow heat exchanger, we will use the  $\epsilon - \text{NTU}$  method, for which

$$C_c = \dot{m}_c c_{p,c} = 0.5 \text{ kg/s} \times 4203 \text{ J/kg}\cdot\text{K} = 2102 \text{ W/K}$$

$$C_h = \dot{m}_h c_{p,h} = 2 \text{ kg/s} \times 1040 \text{ J/kg}\cdot\text{K} = 2080 \text{ W/K}$$

$$C_r = C_{\min} / C_{\max} = 0.990$$

$$q_{\max} = C_{\min} (T_{h,i} - T_{c,i}) = 2080 \text{ W/K} (325 - 25)^\circ\text{C} = 6.24 \times 10^5 \text{ W}$$

$$q = C_c (T_{c,o} - T_{c,i}) = 2102 \text{ W/K} (150 - 25)^\circ\text{C} = 2.63 \times 10^5 \text{ W}$$

Thus

$$\epsilon = q/q_{\max} = 0.421$$

and from Figure 11.14 or solving Eq. 11.32 iteratively for NTU,

$$\text{NTU} = 0.81$$

and

$$U = C_{\min} \text{NTU} / A = 2080 \text{ W/K} \times 0.81 / 10 \text{ m}^2 = 168 \text{ W/m}^2\cdot\text{K}$$

<

**COMMENTS:** The hot outlet temperature is found from  $q = C_h (T_{h,i} - T_{h,o})$  to be  $199^\circ\text{C}$ , thus properties of the hot fluid should be evaluated at around  $262^\circ\text{C}$ . This will have little effect since  $c_p$  is not a strong function of temperature for water.

### PROBLEM 11.10

**KNOWN:** Heat exchanger with two shell passes and eight tube passes having an area  $925\text{m}^2$ ;  $45,500\text{ kg/h}$  water is heated from  $80^\circ\text{C}$  to  $150^\circ\text{C}$ ; hot exhaust gases enter at  $350^\circ\text{C}$  and exit at  $175^\circ\text{C}$ .

**FIND:** Overall heat transfer coefficient.

**SCHEMATIC:**

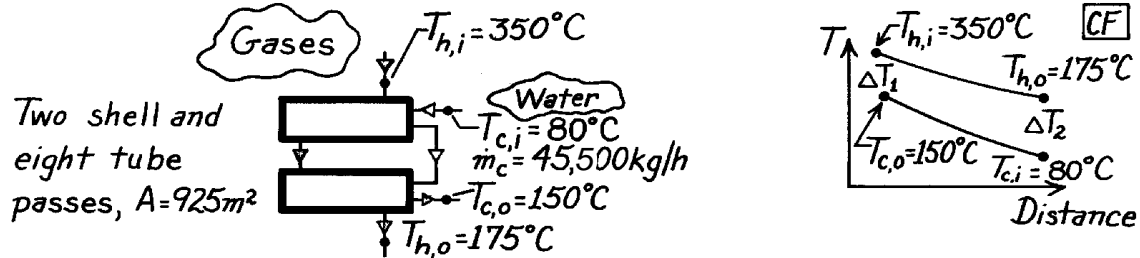

**ASSUMPTIONS:** (1) Negligible losses to surroundings, (2) Constant properties, (3) Exhaust gas properties are approximated as those of atmospheric air.

**PROPERTIES:** Table A-6, Water ( $\bar{T}_c = (80 + 150)^\circ\text{C} / 2 = 388\text{K}$ ):  $c_c = c_{p,f} = 4236\text{ J/kg}\cdot\text{K}$ .

**ANALYSIS:** Since this is a shell-and-tube heat exchanger, we will use the  $\epsilon$  - NTU method, for which

$$C_c = \dot{m}_c c_c = \frac{45,500\text{ kg/h}}{3600\text{ s/h}} \times 4236\text{ J/kg}\cdot\text{K} = 5.35 \times 10^4\text{ W/K}$$

$$q = C_c(T_{c,o} - T_{c,i}) = 5.35 \times 10^4\text{ W/K} (150 - 80)^\circ\text{C} = 3.75 \times 10^6\text{ W}$$

Then we can find  $C_h$  from an energy balance on the hot stream,

$$C_h = q / (T_{h,i} - T_{h,o}) = 3.75 \times 10^6\text{ W} / (350 - 175)^\circ\text{C} = 2.14 \times 10^4\text{ W/K}$$

Thus

$$C_r = C_{\min} / C_{\max} = 0.40$$

$$\epsilon = q / C_{\min} (T_{h,i} - T_{c,i}) = 3.75 \times 10^6\text{ W} / 2.14 \times 10^4\text{ W/K} (350 - 80)^\circ\text{C} = 0.648$$

From Eqs. 11.31b and c, with  $n = 2$ ,

$$F = \left( \frac{\epsilon C_r - 1}{\epsilon - 1} \right)^{1/n} = 1.45, \quad \epsilon_1 = \frac{F - 1}{F - C_r} = 0.429$$

From Eqs. 11.30c and 11.30b,

$$E = \frac{2/\epsilon_1 - (1 + C_r)}{(1 + C_r^2)^{1/2}} = 3.0$$

$$(\text{NTU})_1 = -(1 + C_r^2)^{-1/2} \ln \left[ \frac{E - 1}{E + 1} \right] = 0.637$$

and from Eq. 11.31d,

$$\text{NTU} = n(\text{NTU})_1 = 1.27$$

Therefore,

$$U = \text{NTU} \times C_{\min} / A = 1.27 \times 2.14 \times 10^4\text{ W/K} / (925\text{ m}^2) = 29.5\text{ W/m}^2\cdot\text{K}$$

<

**COMMENTS:** Compare the above result with representative values for air-water exchangers, as given in Table 11.2.



## PROBLEM 11.11

**KNOWN:** Geometry of heat exchanger made from extruded polypropylene sheets. Thermal conductivity of polypropylene. Temperature, pressure, and velocity, of air and carbon dioxide flowing in channels.

**FIND:** Product of overall heat transfer coefficient and surface area,  $UA$ , for 200 cool and 200 warm channels.

**SCHEMATIC:**

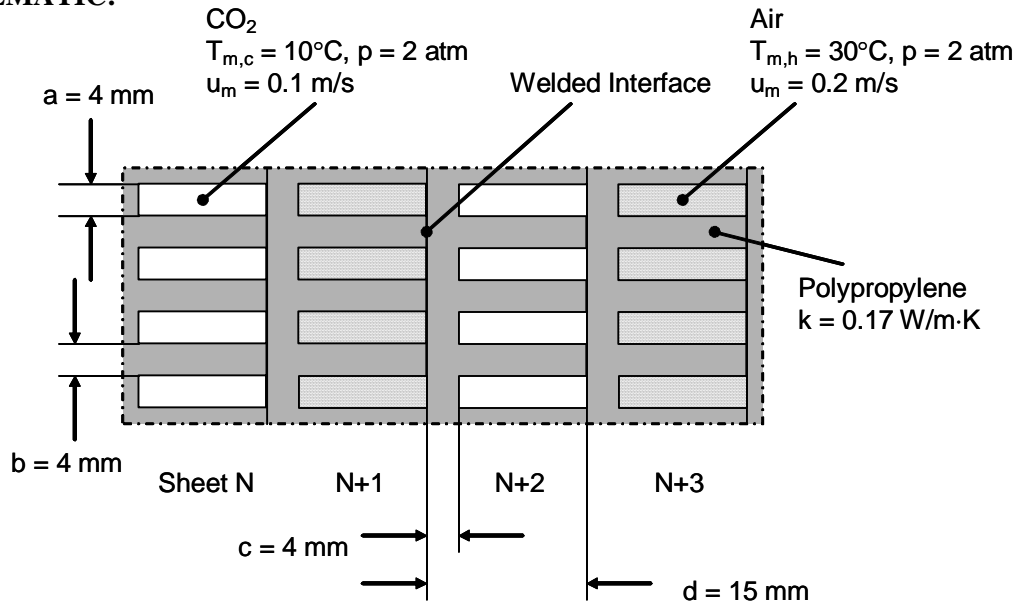

**ASSUMPTIONS:** (1) Constant properties and steady-state conditions, (2) Density of air and  $\text{CO}_2$  is proportional to pressure, (3) Wall temperature is approximately uniform along channels, (4) Thermal resistance at welded interface is negligible, (5) Channel walls can be treated as fins.

**PROPERTIES:** Table A.5, Air: ( $T_{m,h} = 303 \text{ K}$ ,  $p = 2 \text{ atm}$ ):  $k_h = 0.0265 \text{ W/m}\cdot\text{K}$ ,  $c_{p,h} = 1007 \text{ J/kg}\cdot\text{K}$ ,  $\mu_h = 186 \times 10^{-7} \text{ N}\cdot\text{s/m}^2$ ,  $\text{Pr}_h = 0.707$ ,  $\rho_h = 2.303 \text{ kg/m}^3$ ;  $\text{CO}_2$  ( $T_{m,c} = 283 \text{ K}$ ):  $k_c = 0.0154 \text{ W/m}\cdot\text{K}$ ,  $c_{p,c} = 833 \text{ J/kg}\cdot\text{K}$ ,  $\mu_c = 141 \times 10^{-7} \text{ N}\cdot\text{s/m}^2$ ,  $\text{Pr}_c = 0.765$ ,  $\rho_c = 3.76 \text{ kg/m}^3$ . Polypropylene (given):  $k_p = 0.17 \text{ W/m}\cdot\text{K}$ .

**ANALYSIS:** We begin by finding the heat transfer coefficients for air and  $\text{CO}_2$ . In both cases, the hydraulic diameter is  $D_h = 4A_c/P = 4 \times 11 \times 4 / (2(11+4)) \text{ mm} = 5.87 \text{ mm}$ . The Reynolds number for air is

$$\text{Re}_{D,h} = \frac{\rho_h u_{m,h} D_h}{\mu_h} = \frac{2.303 \text{ kg/m}^3 \times 0.2 \text{ m/s} \times 0.00587 \text{ m}}{186 \times 10^{-7} \text{ N}\cdot\text{s/m}^2} = 145$$

A similar calculation for  $\text{CO}_2$  gives  $\text{Re}_{D,c} = 156$ , thus both flows are laminar. From Table 8.1, assuming uniform wall temperature and interpolating for an aspect ratio of  $(d-c)/a = 2.75$ , we find  $\text{Nu}_D = 3.82$ . Then for air,

Continued...

### PROBLEM 11.11 (Cont.)

$$h_h = \text{Nu}_{D,h} k_h / D_h = 3.82 \times 0.0265 \text{ W/m} \cdot \text{K} / 0.00587 \text{ m} = 17.2 \text{ W/m}^2 \cdot \text{K}$$

And a similar calculation for CO<sub>2</sub> yields  $h_c = 10.0 \text{ W/m}^2 \cdot \text{K}$ .

Focusing on one vertical wall of thickness  $c$  in the schematic above, we see that it has fins extending to the right and left into the two fluids. By symmetry, the midpoint of those fins is an adiabat, and we can treat the fins as having length  $L = (d-c)/2 = 5.5 \text{ mm}$ , with an insulated tip. We will use Eq. 11.1 for  $UA$ , with Eqs. 11.3 and 11.4 for the fin efficiency. Note that for channels of length  $w$ ,  $P/A_c = 2(w+b)/wb \approx 2/b$ . For air,

$$m_h = \sqrt{\frac{h_h P}{k_p A_c}} = \sqrt{\frac{2h_h}{k_p b}} = \sqrt{\frac{2 \times 17.2 \text{ W/m}^2 \cdot \text{K}}{0.17 \text{ W/m} \cdot \text{K} \times 0.004 \text{ m}}} = 225 \text{ m}^{-1}$$

$$m_h L = 225 \text{ m}^{-1} \times 0.0055 \text{ m} = 1.24$$

$$\eta_{f,h} = \tanh(m_h L) / m_h L = \tanh(1.24) / 1.24 = 0.682$$

Then  $A_f/A = 2L/(2L + a) = 0.733$  and

$$\eta_{o,h} = 1 - \frac{A_f}{A} (1 - \eta_{f,h}) = 1 - 0.733(1 - 0.682) = 0.767$$

A similar calculation for CO<sub>2</sub> yields  $\eta_{o,c} = 0.839$ . Finally, we use Eq. 11.1 to calculate  $UA$ .

Note that for  $N = 200$  channels (and  $N$  fins) of depth  $w$ ,  $A = 2LwN + awN = 3w \text{ m}^2$  and  $A_w = (a+b)wN = 1.6w \text{ m}^2$ . Thus, for a unit length of the heat exchanger ( $w = 1 \text{ m}$ ),

$$\begin{aligned} \frac{1}{UA} &= \frac{1}{(\eta_o h A)_c} + \frac{c}{k_p A_w} + \frac{1}{(\eta_o h A)_c} \\ &= \frac{1}{0.839 \times 10.0 \text{ W/m}^2 \cdot \text{K} \times 3 \text{ m}^2} + \frac{0.004 \text{ m}}{0.17 \text{ W/m} \cdot \text{K} \times 1.6 \text{ m}^2} + \frac{1}{0.767 \times 17.2 \text{ W/m}^2 \cdot \text{K} \times 3 \text{ m}^2} \end{aligned}$$

$$UA = 12.6 \text{ W/m}^2 \cdot \text{K}$$

<

**COMMENTS:** (1) The product of the overall heat transfer coefficient and the heat transfer area is not large, but the design enables production of a compact heat exchanger that is not prone to corrosion and can be constructed at low cost. (2) The low thermal conductivity of the “fins” may result in significant temperature variation across their thickness, rendering the assumption of one-dimensional heat transfer in these extended surfaces invalid. (3) The contact resistance at the welded interfaces may not be negligible. In this case the system is not symmetric about the channel centerlines. (4) A numerical solution could account for two-dimensional conduction and address the considerations of Comments 2 and 3. (5) The thermal boundary condition at the channel boundaries is neither constant temperature nor constant heat flux. (6) Polypropylene is a semitransparent material (see Chapter 12) and radiation transfer may occur between the two gases. Since the temperatures are relatively low and the convective heat transfer coefficient is relatively high, radiation heat transfer will not be significant.

### PROBLEM 11.12

**KNOWN:** Properties and flow rates for the hot and cold fluid of a heat exchanger.

**FIND:** Which fluid limits the heat transfer rate of the exchanger?

**ASSUMPTIONS:** (1) Steady-state conditions, (2) Constant properties, and (3) Negligible losses to the surroundings.

**ANALYSIS:** The properties and flow rates for the hot and cold fluid of the heat exchanger are tabulated below.

	<i>Cold fluid</i>	<i>Hot fluid</i>
Density, kg/m <sup>3</sup>	997	1247
Specific heat, J/kg·K	4179	2564
Thermal conductivity, W/m·K	0.613	0.287
Viscosity, N·s/m <sup>2</sup>	$8.55 \times 10^{-4}$	$1.68 \times 10^{-4}$
Flow rate, m <sup>3</sup> /h	14	16

The fluid which limits the heat transfer rate of the exchanger is the minimum fluid,

$C_{\min} = (\dot{m} \cdot c)_{\min}$ . For the hot and cold fluids, find

$$C_h = \dot{m}_h c_h = 16 \text{ m}^3 / \text{h} \times 1247 \text{ kg} / \text{m}^3 \times 2564 \text{ J} / \text{kg} \cdot \text{K} \times (1\text{h} / 3600\text{s}) = 14.21 \text{ kW} / \text{K}$$

$$C_c = \dot{m}_c c_c = 14 \text{ m}^3 / \text{h} \times 997 \text{ kg} / \text{m}^3 \times 4179 \text{ J} / \text{kg} \cdot \text{K} \times (1\text{h} / 3600\text{s}) = 16.20 \text{ kW} / \text{K}$$

Hence, the hot fluid is the minimum fluid,

$$C_{\min} = C_h \quad <$$

For any exchanger, the heat rate is  $q = \varepsilon q_{\max}$ , where  $\varepsilon$  depends upon the exchanger type. The maximum heat rate is  $q_{\max} = C_{\min} (T_{h,i} - T_{c,i})$ . Hence, it is the conditions for the minimum fluid that limit the performance of the exchanger.

### PROBLEM 11.13

**KNOWN:** Process (hot) fluid having a specific heat of 3500 J/kg·K and flowing at 2 kg/s is to be cooled from 80°C to 50°C with chilled-water (cold fluid) supplied at 2.5 kg/s and 15°C assuming an overall heat transfer coefficient of 2000 W/m<sup>2</sup>·K.

**FIND:** The required heat transfer areas for the following heat exchanger configurations; (a) Concentric tube (CT) - parallel flow, (b) CT - counterflow, (c) Shell and tube, one-shell pass and 2 tube passes; (d) Cross flow, single pass, both fluids unmixed. Use the *IHT Tools | Heat Exchanger* models as your solution tool.

**SCHEMATIC:**

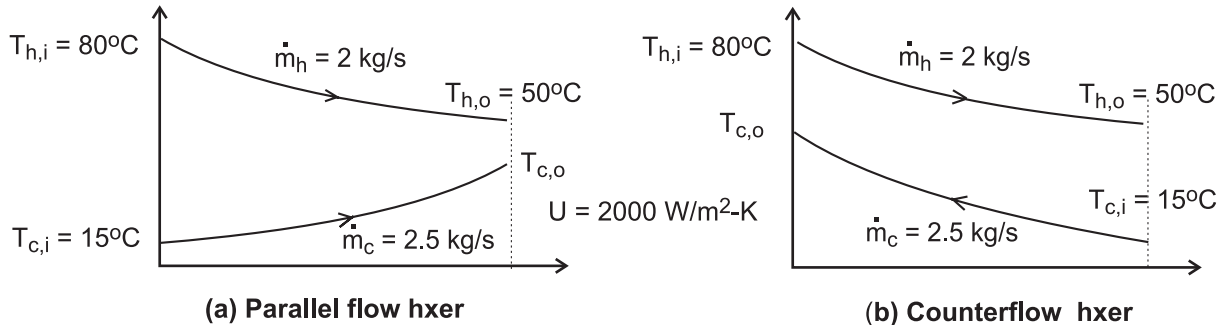

**ASSUMPTIONS:** (1) Steady-state conditions, (2) Negligible losses to the surroundings, (3) Overall heat transfer coefficient remains constant with different configurations, and (4) Constant properties.

**ANALYSIS:** The *IHT Tools | Heat Exchanger* models are based upon the effectiveness-NTU method and suited for design-type problems. The table below summarizes the results of our analysis using the IHT models including model equations, figures, and the required heat transfer area. The cold fluid outlet temperature for all configurations is  $T_{c,o} = 35.1^\circ\text{C}$ . The IHT code for the concentric tube, parallel flow heat exchanger is provided in the Comments.

Heat exchanger type	Eqs.	Figs	$A(\text{m}^2)$
(a) CT -Parallel flow	11.28b	11.10	3.09
(b) CT -Counterflow	11.29b	11.11	2.64
(c) Shell and tube (1 - sp, 2 - tp)	11.30b	11.12	2.83
(d) Crossflow (1 - p, unmixed)	11.32	11.14	2.84

**COMMENTS:** (1) Referring to the tabulated results, note that for the concentric tube exchangers, the area required for parallel flow is 17% larger than for counterflow. Under what circumstances would you choose to use the PF arrangement if the area has to be significantly larger?

(2) The shell-tube and crossflow exchangers require nearly the same heat transfer area. What are other factors that might influence your decision to select one type over the other for an application?

(3) Based upon area considerations only, the CF arrangement requires the smallest heat transfer area. What practical issues need to be considered in making a CF heat exchanger with a 2.6 m<sup>2</sup> area?

Continued ...

## PROBLEM 11.13 (Cont.)

(4) The *IHT* code used for the concentric tube, parallel flow heat exchanger is shown below. Note the use of the water property function, *cp\_Tx*, and the intrinsic function, *Tfluid\_avg*, to provide the specific heat at the mean water (cold fluid) temperature.

```

// Results - energy balance only
Cc          Ch          Tco      cc          q          Tci       Thi       Tho       ch
1.045E4     7000          35.1     4180        2.1E5      15        80        50        3500*/

// Results of sizing
A          CR          NTU      eps
3.87      0.6699    0.882    0.4615 */

// Design conditions
Thi = 80
Tho = 50
mdoth = 2
ch = 3500
mdotc = 2.5
Tci = 15
U = 2000

// For the parallel-flow, concentric-tube heat exchanger,
// For the parallel-flow, concentric-tube heat exchanger,
NTU = -ln(1 - eps * (1 + Cr))/(1 + Cr) // Eq 11.28b
// where the heat-capacity ratio is
Cr = Cmin/Cmax
// and the number of transfer units, NTU, is
NTU = U * A/Cmin // Eq 11.24
// The effectiveness is defined as
eps = q/qmax
qmax = Cmin * (Thi - Tci) // Eq 11.18, 11.19
// See Tables 11.3 and 11.4 and Fig 11.14

// Energy balances
q = Cc * (Tco - Tci)
q = Ch * (Thi - Tho)
Cc = mdotc * cc
Ch = mdoth * ch
Cmin = Ch
Cmax = Cc

// Water property functions: T dependence, From Table A.6
// Units: T(K), p(bars):
xc = 0 // Quality (0=sat liquid or 1=sat vapor)
cc = cp_Tx("Water", Tcm,xc) // Specific heat, J/kg-K
Tcm = Tfluid_avg(Tci, Tco) // Mean temperature; K; intrinsic function

```

### PROBLEM 11.14

**KNOWN:** A shell and tube Hxer (two shells, four tube passes) heats 10,000 kg/h of pressurized water from 35°C to 120°C with 5,000 kg/h water entering at 300°C.

**FIND:** Required heat transfer area,  $A_s$ .

**SCHEMATIC:**

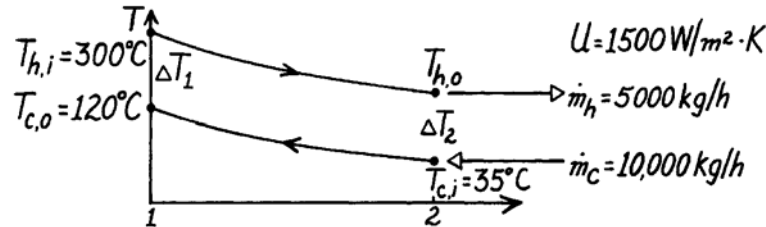

**ASSUMPTIONS:** (1) Negligible heat loss to surroundings, (2) Constant properties.

**PROPERTIES:** Table A-6, Water ( $\bar{T}_c = 350$  K):  $c_p = 4195$  J/kg·K; Table A-6, Water (Assume  $T_{h,o} \approx 150^\circ\text{C}$ ,  $\bar{T}_h \approx 500$  K):  $c_p = 4660$  J/kg·K.

**ANALYSIS:** For a shell and tube heat exchanger, we use the  $\epsilon$  – NTU method. An energy balance on the cold fluid yields

$$q = \dot{m}_c c_{p,c} (T_{c,o} - T_{c,i}) = \frac{10,000 \text{ kg/h}}{3600 \text{ s/h}} \times 4195 \frac{\text{J}}{\text{kg} \cdot \text{K}} (120 - 35) \text{ K} = 9.905 \times 10^5 \text{ W}.$$

An energy balance on the hot fluid yields

$$T_{h,o} = T_{h,i} - q / \dot{m}_h c_{p,h} = 300^\circ\text{C} - 9.905 \times 10^5 \text{ W} / \frac{5000 \text{ kg}}{3600 \text{ s}} \times 4660 \frac{\text{J}}{\text{kg} \cdot \text{K}} = 147^\circ\text{C}.$$

Thus  $\bar{T}_h = (300 + 147)^\circ\text{C}/2 = 497$  K is the proper temperature for evaluating properties of the hot fluid. Then

$$C_c = \dot{m}_c c_{p,c} = \frac{10,000 \text{ kg/h}}{3,600 \text{ s/h}} \times 4195 \text{ J/kg} \cdot \text{K} = 11,650 \text{ W/K}$$

$$C_h = \dot{m}_h c_{p,h} = \frac{5,000 \text{ kg/h}}{3,600 \text{ s/h}} \times 4660 \text{ J/kg} \cdot \text{K} = 6470 \text{ W/K}$$

$$C_r = C_{\min} / C_{\max} = 6470 / 11,650 = 0.555$$

$$q_{\max} = C_{\min} (T_{h,i} - T_{c,i}) = 6470 \text{ W/K} (300 - 35)^\circ\text{C} = 1.75 \times 10^6 \text{ W}$$

$$\epsilon = q / q_{\max} = 9.905 \times 10^5 \text{ W} / 1.72 \times 10^6 \text{ W} = 0.577$$

From Eqs. 11.31c, 11.31b, and 11.30c, with  $n=2$ ,

$$F = \left( \frac{\epsilon C_r - 1}{\epsilon - 1} \right)^{1/n} = 1.27, \quad \epsilon_1 = \frac{F - 1}{F - C_r} = 0.376$$

$$E = \frac{2/\epsilon_1 - (1 + C_r)}{(1 + C_r^2)^{1/2}} = 3.29$$

then from Eqs. 11.30b and 11.31d,

$$\text{NTU} = n (\text{NTU})_1 = -n (1 + C_r^2)^{-1/2} \ln \left[ \frac{E - 1}{E + 1} \right] = 1.10$$

Finally,

$$A = \text{NTU} \times C_{\min} / U = (1.10 \times 6470 \text{ W/K}) / (1500 \text{ W/m}^2 \cdot \text{K}) = 4.75 \text{ m}^2$$

<

### PROBLEM 11.15

**KNOWN:** The shell and tube Hxer (two shells, four tube passes) of Problem 11.14, known to have an area  $4.75\text{m}^2$ , provides  $95^\circ\text{C}$  water at the cold outlet (rather than  $120^\circ\text{C}$ ) after several years of operation. Flow rates and inlet temperatures of the fluids remain the same.

**FIND:** The fouling factor,  $R_f$ .

**SCHEMATIC:**

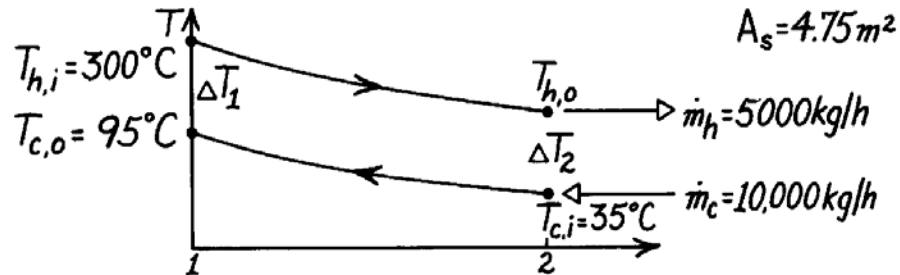

**ASSUMPTIONS:** (1) Negligible heat loss to surroundings, (2) Constant properties, (3) Thermal resistance for the clean condition is  $R_t'' = (1500 \text{ W/m}^2 \cdot \text{K})^{-1}$ .

**PROPERTIES:** Table A-6, Water ( $\bar{T}_c \approx 338 \text{ K}$ ):  $c_p = 4187 \text{ J/kg} \cdot \text{K}$ ; Table A-6, Water (Assume  $T_{h,o} \approx 190^\circ\text{C}$ ,  $\bar{T}_h \approx 520 \text{ K}$ ):  $c_p = 4840 \text{ J/kg} \cdot \text{K}$ .

**ANALYSIS:** The overall heat transfer coefficient can be expressed as

$$U = 1/(R_t'' + R_f'') \quad \text{or} \quad R_f'' = 1/U - R_t'' \quad (1)$$

where  $R_t''$  is the thermal resistance for the clean condition and  $R_f''$ , the fouling factor, represents the additional resistance due to fouling of the surface. We use the  $\epsilon - \text{NTU}$  method as follows,

$$C_c = \dot{m}_c c_{p,c} = \frac{10,000 \text{ kg/h}}{3,600 \text{ s/h}} \times 4187 \text{ J/kg} \cdot \text{K} = 1.16 \times 10^4 \text{ W/K}$$

$$C_h = \dot{m}_h c_{p,h} = \frac{5,000 \text{ kg/h}}{3,600 \text{ s/h}} \times 4840 \text{ J/kg} \cdot \text{K} = 6.72 \times 10^3 \text{ W/K}$$

$$C_r = C_{\min} / C_{\max} = 0.578$$

$$q_{\max} = C_{\min} (T_{h,i} - T_{c,i}) = 6.72 \times 10^3 \text{ W/K} (300 - 35)^\circ\text{C} = 1.78 \times 10^6 \text{ W}$$

$$q = C_c (T_{c,o} - T_{c,i}) = 1.16 \times 10^4 \text{ W/K} (95 - 35)^\circ\text{C} = 6.98 \times 10^5 \text{ W}$$

$$\epsilon = q/q_{\max} = 0.392$$

Note, that  $T_{h,o} = T_{h,i} - q/C_h = 196^\circ\text{C}$ , so properties should be evaluated at

$\bar{T}_h = (T_{h,i} + T_{h,o})/2 = 248^\circ\text{C} = 521 \text{ K}$ , very close to the assumed value. From Eqs. 11.31 and 11.30, with  $n = 2$ ,

$$F = \left( \frac{\epsilon C_r - 1}{\epsilon - 1} \right)^{1/n} = 1.13, \quad \epsilon_1 = \frac{F - 1}{F - C_r} = 0.232,$$

$$E = \frac{2/\epsilon_1 - (1 + C_r)}{(1 + C_r^2)^{1/2}} = 6.09$$

$$\text{NTU} = -n (1 + C_r^2)^{-1/2} \ln \left[ \frac{E - 1}{E + 1} \right] = 0.574$$

Continued...

### PROBLEM 11.15 (Cont.)

Thus,

$$U = NTU \times C_{\min}/A = (0.574 \times 6.72 \times 10^3 \text{ W/K})/(4.75 \text{ m}^2) = 813 \text{ W/m}^2 \cdot \text{K}$$

From Eq. (1), the fouling factor is

$$R_f'' = \frac{1}{813 \text{ W/m}^2 \cdot \text{K}} - \frac{1}{1500 \text{ W/m}^2 \cdot \text{K}} = 5.64 \times 10^{-4} \text{ m}^2 \cdot \text{K/W}. \quad <$$

**COMMENTS:** Note that the effect of fouling is to nearly double ( $U_{\text{clean}}/U_{\text{fouled}} = 1500/813 \approx 1.9$ ) the resistance to heat transfer. Note also the assumption for  $T_{h,o}$  used for property evaluation is satisfactory.



## PROBLEM 11.16

**KNOWN:** Inlet and outlet temperatures of hot and cold fluid streams in a concentric tube heat exchanger.

**FIND:** Whether the heat exchanger is operated in counter- or parallel flow, heat exchanger effectiveness, heat exchanger NTU.

**SCHEMATIC:**

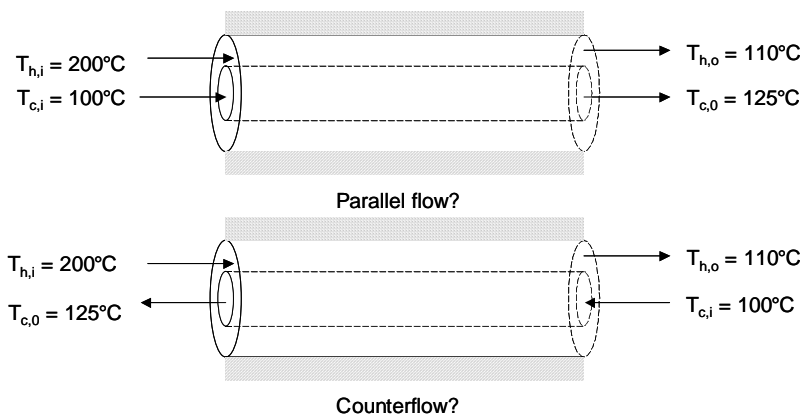

**ASSUMPTIONS:** (1) Negligible heat transfer between the heat exchanger and the surroundings, (2) Constant properties.

**ANALYSIS:** The heat exchanger must be operating in a counterflow configuration because  $T_{h,o} < T_{c,o}$ . <

From energy balances on each fluid,  $q = C_h(T_{h,i} - T_{h,o}) = C_c(T_{c,o} - T_{c,i})$ , from which

$$C_h/C_c = C_{\min}/C_{\max} = (T_{c,o} - T_{c,i})/(T_{h,i} - T_{h,o}) = 25/90 = 0.278 \text{ and } C_{\min} = C_h.$$

From the definition of the effectiveness,  $q = \varepsilon C_{\min}(T_{h,i} - T_{c,i}) = \varepsilon C_h(T_{h,i} - T_{c,i}) = C_h(T_{h,o} - T_{h,i})$  from which

$$\varepsilon = (T_{h,o} - T_{h,i})/(T_{h,i} - T_{c,i}) = 90/100 = 0.90 \quad <$$

From Fig. 11.11,  $NTU \approx 2.8$  <

**COMMENTS:** The NTU may also be found from Eq. 11.28b, yielding  $NTU = 2.79$ .

## PROBLEM 11.17

**KNOWN:** Inlet temperatures of pharmaceutical product and water in a concentric tube heat exchanger. Tube diameters and fluid velocities.

**FIND:** (a) Value of the overall heat transfer coefficient,  $U$ , (b) Mean outlet temperature of the pharmaceutical product for counterflow operation, (c) Mean outlet temperature of the pharmaceutical product for parallel-flow operation.

**SCHEMATIC:**

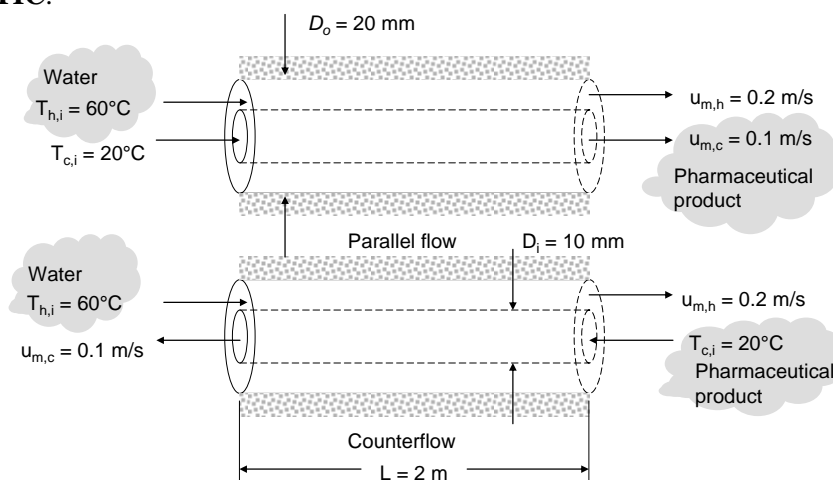

**ASSUMPTIONS:** (1) Negligible heat transfer between the heat exchanger and the surroundings, (2) Constant properties, (3) Negligible conduction resistance posed by the thin-walled inner tube, (4) Smooth tube surfaces.

**PROPERTIES:** Pharmaceutical product (given):  $\nu = 10 \times 10^{-6} \text{ m}^2/\text{s}$ ,  $k = 0.25 \text{ W/m}\cdot\text{K}$ ,  $\rho = 1100 \text{ kg/m}^3$  and  $c_p = 2460 \text{ J/kg}\cdot\text{K}$ . Table A.6, water ( $\bar{T}_h = 50^\circ\text{C}$ ):  $\nu = 5.54 \times 10^{-7} \text{ m}^2/\text{s}$ ,  $k = 0.643 \text{ W/m}\cdot\text{K}$ ,  $\rho = 987.9 \text{ kg/m}^3$ ,  $Pr = 3.56$  and  $c_p = 4181 \text{ J/kg}\cdot\text{K}$ .

**ANALYSIS:** (a) The Prandtl number of the pharmaceutical product is  $Pr_c = \rho c_p \nu / k = (1100 \text{ kg/m}^3 \times 2460 \text{ J/kg}\cdot\text{K} \times 10 \times 10^{-6} \text{ m}^2/\text{s}) / 0.25 \text{ W/m}\cdot\text{K} = 108$ . The overall heat transfer coefficient is  $U = (1/h_i + 1/h_o)^{-1}$ . For the flow in the inner tube,  $Re_{D_i} = u_{m,c} D_i / \nu = (0.1 \text{ m/s} \times 0.01 \text{ m}) / 10 \times 10^{-6} \text{ m}^2/\text{s} = 100$ . The thermal entrance length is  $x_{fd,t} = 0.05 Re_{D_i} Pr D_i = 0.05 Re_{D_i} (\rho c_p \nu / k) D_i = 0.05 \times 100 \times (1100 \text{ kg/m}^3 \times 2460 \text{ J/kg}\cdot\text{K} \times 10 \times 10^{-6} \text{ m}^2/\text{s} / 0.25 \text{ W/m}\cdot\text{K}) \times 0.01 \text{ m} = 5.41 \text{ m}$ . Therefore, entrance effects are important. The Hausen correlation is appropriate for determining the average Nusselt number associated with the inner tube flow.

$$\overline{Nu}_{D_i} = 3.66 + \frac{0.0668(D/L)Re_{D_i}Pr}{1 + 0.04[(D/L)Re_{D_i}Pr]^{2/3}} = 3.66 + \frac{0.0668 \times (0.01/2) \times 100 \times 108}{1 + 0.04[(0.01/2) \times 100 \times 108]^{2/3}} = 5.96$$

Therefore,

$$h_i = \frac{\overline{Nu}_{D_i} k}{D_i} = \frac{5.96 \times 0.25 \text{ W/m}\cdot\text{K}}{0.01 \text{ m}} = 149 \text{ W/m}^2 \cdot \text{K}$$

Continued...

### Problem 11.17 (Cont.)

For the annular flow,  $Re_{Dh} = u_{m,h}(D_o - D_i)/\nu = 0.2 \text{ m/s} \times 0.01 \text{ m}/5.54 \times 10^{-7} \text{ m}^2/\text{s} = 3610$ . Hence, the Gnielinski correlation is appropriate for use. The friction factor for the annular region is obtained from Eq. 8.21 and is

$$f = (0.790 \ln Re_{Dh} - 1.64)^{-2} = (0.790 \ln(3610) - 1.64)^{-2} = 0.0428$$

Therefore,

$$\overline{Nu}_{Dh} = \frac{(f/8)(Re_{Dh} - 1000)Pr}{1 + 12.7(f/8)^{1/2}(Pr^{2/3} - 1)} = \frac{(0.0428/8)(3610 - 1000)3.56}{1 + 12.7(0.0428/8)^{1/2}(3.56^{2/3} - 1)} = 22.22$$

and

$$h_o = \frac{\overline{Nu}_{Dh}k}{D_o - D_i} = \frac{22.22 \times 0.643 \text{ W/m} \cdot \text{K}}{0.01 \text{ m}} = 1430 \text{ W/m}^2 \cdot \text{K}$$

The overall heat transfer coefficient is

$$U = (1/h_i + 1/h_o)^{-1} = [1/(149 \text{ W/m}^2 \cdot \text{K}) + 1/(1430 \text{ W/m}^2 \cdot \text{K})]^{-1} = 135 \text{ W/m}^2 \cdot \text{K} \quad <$$

(b) The heat capacity rate of the cold (pharmaceutical product) stream is

$$C_c = \dot{m}_c c_p = \left[ u_{m,c} \rho \pi D_i^2 / 4 \right] c_p = \left[ \frac{0.1 \text{ m/s} \times 1100 \text{ kg/m}^3 \times \pi \times (0.01 \text{ m})^2}{4} \right] \times 2460 \text{ J/kg} \cdot \text{K} = 21.3 \text{ W/K}$$

The heat capacity rate of the hot (water) stream is

$$C_c = \dot{m}_c c_p = \left[ u_{m,c} \rho \pi (D_o^2 - D_i^2) / 4 \right] c_p \\ = \left[ \frac{0.2 \text{ m/s} \times 987.9 \text{ kg/m}^3 \times \pi \times [(0.02 \text{ m})^2 - (0.01 \text{ m})^2]}{4} \right] \times 4181 \text{ J/kg} \cdot \text{K} = 195 \text{ W/K}$$

Therefore,  $C_r = C_{\min}/C_{\max} = (21.3 \text{ W/K})/(195 \text{ W/K}) = 0.11$  and the number of transfer units is  $NTU = UA/C_{\min} = U\pi D_i L/C_{\min} = (135 \text{ W/m}^2 \cdot \text{K} \times \pi \times 0.01 \text{ m} \times 2 \text{ m})/21.3 \text{ W/K} = 0.398$ . The effectiveness of the counterflow heat exchanger is obtained from Eq. 11.29a and is

$$\varepsilon = \frac{1 - \exp[-NTU(1 - C_r)]}{1 - C_r \exp[-NTU(1 - C_r)]} = \frac{1 - \exp[-0.398(1 - 0.11)]}{1 - 0.11 \exp[-0.398(1 - 0.11)]} = 0.323$$

Continued...

### Problem 11.17 (Cont.)

The heat transfer rate is

$$q = \dot{m}_c c_p (T_{c,o} - T_{c,i}) = \varepsilon C_{\min} (T_{h,i} - T_{c,i}) \quad \text{from which}$$

$$T_{c,o} = T_{c,i} + \frac{\varepsilon C_{\min} (T_{h,i} - T_{c,i})}{\rho u_{m,c} (\pi D_i^2 / 4) c_p} = 20^\circ\text{C} + \frac{0.323 \times 21.3 \text{ W/K} \times (60^\circ\text{C} - 20^\circ\text{C})}{1100 \text{ kg/m}^3 \times 0.1 \text{ m/s} \times (\pi (0.01 \text{ m})^2 / 4) 2460 \text{ J/kg} \cdot \text{K}} = 33.0^\circ\text{C} <$$

(c) For parallel-flow operation,

$$\varepsilon = \frac{1 - \exp[-NTU(1 + C_r)]}{1 + C_r} = \frac{1 - \exp[-0.398(1 + 0.11)]}{1 + 0.11} = 0.322$$

Therefore, the cold stream outlet temperature is

$$T_{c,o} = T_{c,i} + \frac{\varepsilon C_{\min} (T_{h,i} - T_{c,i})}{\rho u_{m,c} (\pi D_i^2 / 4) c_p} = 20^\circ\text{C} + \frac{0.322 \times 21.3 \text{ W/K} \times (60^\circ\text{C} - 20^\circ\text{C})}{1100 \text{ kg/m}^3 \times 0.1 \text{ m/s} \times (\pi (0.01 \text{ m})^2 / 4) 2460 \text{ J/kg} \cdot \text{K}} = 31.2^\circ\text{C} <$$

**COMMENTS:** There is little difference in the outlet temperature of the pharmaceutical product. However, if the outlet temperature of the pharmaceutical product cannot exceed some critical value, the heat exchanger should be operated in parallel-flow since the ultimate outlet temperature associated with a very long concentric tube apparatus would be determined by the conservation of energy principle.

## PROBLEM 11.18

**KNOWN:** Inner tube diameter ( $D = 0.02 \text{ m}$ ) and fluid inlet and outlet temperatures corresponding to design conditions for a counterflow, concentric tube heat exchanger. Overall heat transfer coefficient ( $U = 500 \text{ W/m}^2\cdot\text{K}$ ) and desired heat rate ( $q = 3000 \text{ W}$ ). Cold fluid outlet temperature after three years of operation.

**FIND:** (a) Required heat exchanger length, (b) Heat rate, hot fluid outlet temperature, overall heat transfer coefficient, and fouling factor after three years.

**SCHEMATIC:**

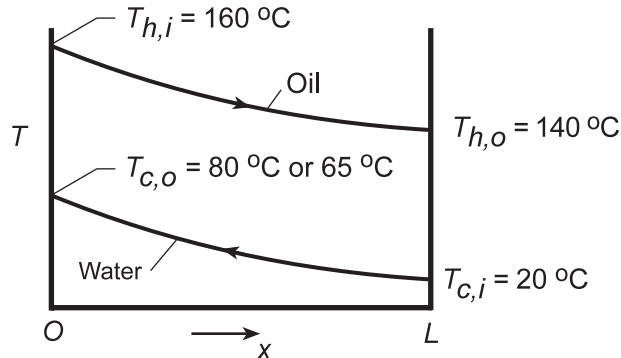

**ASSUMPTIONS:** (1) Negligible heat loss to the surroundings, (2) Negligible tube wall conduction resistance, (3) Constant properties.

**ANALYSIS:** (a) The tube length needed to achieve the prescribed conditions may be obtained from Eqs. 11.14 and 11.15 where  $\Delta T_1 = T_{h,i} - T_{c,o} = 80^\circ\text{C}$  and  $\Delta T_2 = T_{h,o} - T_{c,i} = 120^\circ\text{C}$ . Hence,  $\Delta T_{1m} = (120 - 80)^\circ\text{C}/\ln(120/80) = 98.7^\circ\text{C}$  and

$$L = \frac{q}{(\pi D)U\Delta T_{1m}} = \frac{3000 \text{ W}}{(\pi \times 0.02 \text{ m})500 \text{ W/m}^2 \cdot \text{K} \times 98.7^\circ\text{C}} = 0.968 \text{ m} \quad <$$

(b) With  $q = C_c(T_{c,o} - T_{c,i})$ , the following ratio may be formed in terms of the design and 3 year conditions.

$$\frac{q}{q_3} = \frac{C_c(T_{c,o} - T_{c,i})}{C_c(T_{c,o} - T_{c,i})_3} = \frac{60^\circ\text{C}}{45^\circ\text{C}} = 1.333$$

Hence,

$$q_3 = q/1.33 = 3000 \text{ W}/1.333 = 2250 \text{ W} \quad <$$

Having determined the ratio of heat rates, it follows that

$$\frac{q}{q_3} = \frac{C_h(T_{h,i} - T_{h,o})}{C_h(T_{h,i} - T_{h,o})_3} = \frac{20^\circ\text{C}}{160^\circ\text{C} - T_{h,o(3)}} = 1.333$$

Hence,

$$T_{h,o(3)} = 160^\circ\text{C} - 20^\circ\text{C}/1.333 = 145^\circ\text{C} \quad <$$

With  $\Delta T_{1m,3} = (125 - 95)/\ln(125/95) = 109.3^\circ\text{C}$ ,

$$U_3 = \frac{q_3}{(\pi DL)\Delta T_{1m,3}} = \frac{2250 \text{ W}}{\pi(0.02 \text{ m})0.968 \text{ m}(109.3^\circ\text{C})} = 338 \text{ W/m}^2 \cdot \text{K} \quad <$$

Continued...

**PROBLEM 11.18 (Cont.)**

With  $U = [(1/h_i) + (1/h_o)]^{-1}$  and  $U_3 = [(1/h_i) + (1/h_o) + R_{f,c}'' ]^{-1}$ ,

$$R_{f,c}'' = \frac{1}{U_3} - \frac{1}{U} = \left( \frac{1}{338} - \frac{1}{500} \right) \text{m}^2 \cdot \text{K/W} = 9.59 \times 10^{-4} \text{m}^2 \cdot \text{K/W}$$

<

**COMMENTS:** Over time fouling will always contribute to a degradation of heat exchanger performance. In practice it is desirable to remove fluid contaminants and to implement a regular maintenance (cleaning) procedure.

## PROBLEM 11.19

**KNOWN:** Counterflow, concentric tube heat exchanger of Example 11.1; maintaining the outlet oil temperature of 60°C, but with variable rate of cooling water, all other conditions remaining the same.

**FIND:** (a) Calculate and plot the required exchanger tube length  $L$  and water outlet temperature  $T_{c,o}$  for the cooling water flow rate in the range 0.15 to 0.3 kg/s, and (b) Calculate  $U$  as a function of the water flow rate assuming the water properties are independent of temperature; justify using a constant value of  $U$  for the part (a) calculations.

**SCHEMATIC:**

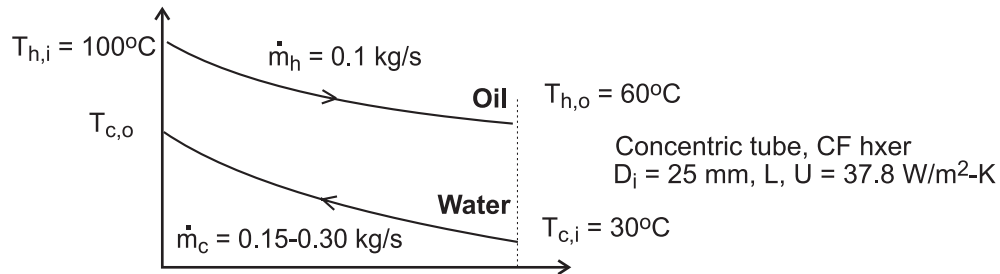

**ASSUMPTIONS:** (1) Steady-state conditions, (2) Negligible losses to the surroundings, (3) Overall heat transfer coefficient independent of water flow rate for this range, and (4) Constant properties.

**PROPERTIES:** Table A-6, Water ( $\bar{T}_c = 35^\circ\text{C} = 308\text{K}$ ):  $c_p = 4178\text{ J/kg}\cdot\text{K}$ ,  $\mu = 725 \times 10^{-6}\text{ N}\cdot\text{s/m}^2$ ,  $k = 0.625\text{ W/m}\cdot\text{K}$ ,  $Pr = 4.85$ , Table A-4, Unused engine oil ( $\bar{T}_h = 353\text{K}$ ):  $c_p = 2131\text{ J/kg}\cdot\text{K}$ .

**ANALYSIS:** (a) The NTU- $\varepsilon$  method will be used to calculate the tube length  $L$  and water outlet temperature  $T_{c,o}$  using this system of equations in the *IHT* workspace:

*NTU relation, CF hxer, Eq. 11.29b*

$$NTU = \frac{1}{C_r - 1} \ln \frac{(\varepsilon - 1)}{(\varepsilon C_r - 1)} \quad C_r = C_{\max} / C_{\min} \quad (1, 2)$$

$$NTU = U \cdot A / C_{\min} \quad (3)$$

$$A = \pi D_i \cdot L \quad (4)$$

*Capacity rates, find minimum fluid*

$$C_h = \dot{m}_h c_h = 0.1\text{ kg/s} \times 2131\text{ J/kg}\cdot\text{K} = 213.1\text{ W/K}$$

$$C_c = \dot{m}_c c_c = (0.15\text{ to }0.30)\text{ kg/s} \times 4178\text{ J/kg}\cdot\text{K} = 626.7 - 1253\text{ W/K} \quad (5)$$

$$C_{\min} = C_h \quad (6)$$

*Effectiveness and maximum heat rate, Eqs. 11.18 and 11.19*

$$\varepsilon = q / q_{\max} \quad (7)$$

$$q_{\max} = C_{\min} (T_{h,i} - T_{c,i}) = C_c (T_{h,i} - T_{c,i}) \quad (8)$$

Continued ...

### PROBLEM 11.19 (Cont.)

$$q = C_h(T_{h,i} - T_{h,o}) \quad (9)$$

With the foregoing equations and the parameters specified in the schematic, the results are plotted in the graphs below.

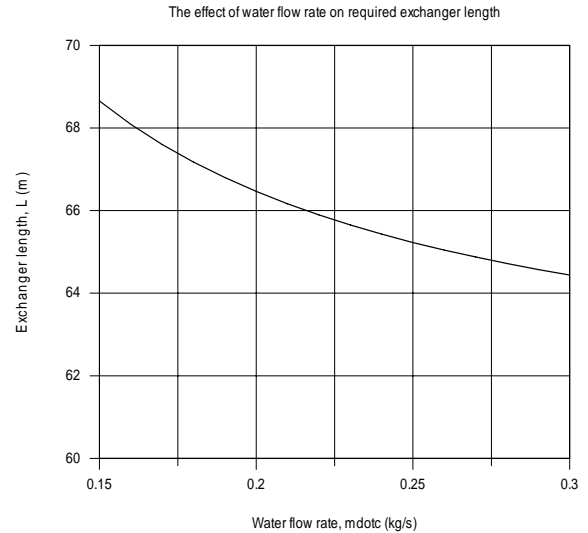
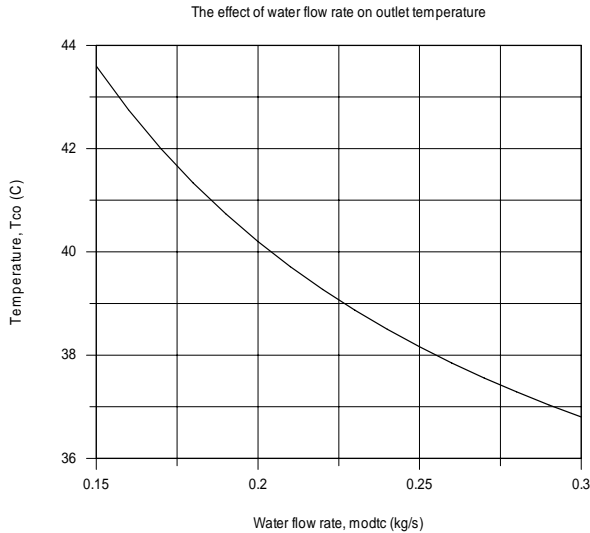

(b) The overall coefficient can be written in terms of the inner (cold) and outer (hot) side convection coefficients,

$$U = 1 / (1 / h_i + 1 / h_o) \quad (10)$$

From Example 11.1,  $h_o = 38.8 \text{ W/m}^2 \cdot \text{K}$ , and  $h_i$  will vary with the flow rate from Eq. 8.60 as

$$h_i = h_{i,b} (\dot{m}_i / \dot{m}_{i,b})^{0.8} \quad (11)$$

where the subscript  $b$  denotes the base case when  $\dot{m}_i = 0.2 \text{ kg/s}$ . From these equations, the results are tabulated.

$\dot{m}_c$ (kg/s)	$h_i$ ( $\text{W/m}^2 \cdot \text{K}$ )	$h_o$ ( $\text{W/m}^2 \cdot \text{K}$ )	$U$ ( $\text{W/m}^2 \cdot \text{K}$ )
0.15	1787	38.8	38.0
0.20	2250	38.8	38.1
0.25	2690	38.8	38.2
0.30	3112	38.8	38.3

Note that while  $h_i$  varies nearly 50%, there is a negligible effect on the value of  $U$ .

**COMMENTS:** Note from the graphical results, that by doubling the flow rate (from 0.15 to 0.30 kg/s), the required length of the exchanger can be decreased by approximately 6%. Increasing the flow rate is not a good strategy for reducing the length of the exchanger. However, any increase in the hot-side (oil) convection coefficient would provide a proportional decrease in the length.



## PROBLEM 11.20

**KNOWN:** Concentric tube heat exchanger with area of  $50 \text{ m}^2$  with operating conditions as shown on the schematic.

**FIND:** (a) Outlet temperature of the hot fluid; (b) Whether the exchanger is operating in counterflow or parallel flow; or can't tell from information provided; (c) Overall heat transfer coefficient; (d) Effectiveness of the exchanger; and (e) Effectiveness of the exchanger if its length is made very long

**SCHEMATIC:**

Operating conditions Concentric tube HXer, $A = 50 \text{ m}^2$		
	Hot fluid (h)	Cold fluid (c)
Capacity rate, kW/K	6	3
Inlet temperature, °C	60	30
Outlet temperature, °C	--	54

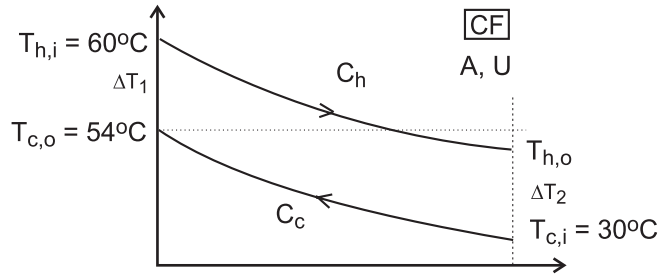

**ASSUMPTIONS:** (1) Negligible heat loss to surroundings, (2) Constant properties.

**ANALYSIS:** From overall energy balances on the hot and cold fluids, find the hot fluid outlet temperature

$$q = C_c (T_{c,o} - T_{c,i}) = C_h (T_{h,i} - T_{h,o}) \quad (1)$$

$$3000 \text{ W/K} (54 - 30) \text{ K} = 6000 (60 - T_{h,o}) \quad T_{h,o} = 48^\circ\text{C} \quad <$$

(b) HXer must be operating in counterflow (CF) since  $T_{h,o} < T_{c,o}$ . See schematic for temperature distribution.

(c) From the rate equation with  $A = 50 \text{ m}^2$ , with Eq. (1) for  $q$ ,

$$q = C_c (T_{c,o} - T_{c,i}) = UA \Delta T_{lm} \quad (2)$$

$$\Delta T_{lm} = \frac{\Delta T_1 - \Delta T_2}{\ln(\Delta T_1 / \Delta T_2)} = \frac{(60 - 54) \text{ K} - (48 - 30) \text{ K}}{\ln(6/18)} = 10.9^\circ\text{C} \quad (3)$$

$$3000 \text{ W/K} (54 - 30) \text{ K} = U \times 50 \text{ m}^2 \times 10.9 \text{ K}$$

$$U = 132 \text{ W/m}^2 \cdot \text{K} \quad <$$

(d) The effectiveness, from Eq. 11.19, with the cold fluid as the minimum fluid,  $C_c = C_{min}$ ,

$$\varepsilon = \frac{q}{q_{max}} = \frac{C_c (T_{c,o} - T_{c,i})}{C_{min} (T_{h,i} - T_{c,i})} = \frac{(54 - 30) \text{ K}}{(60 - 30) \text{ K}} = 0.8 \quad <$$

(e) For a very long CF HXer, the outlet of the minimum fluid,  $C_{min} = C_c$ , will approach  $T_{h,i}$ . That is,

$$q \rightarrow C_{min} (T_{c,o} - T_{c,i}) \rightarrow q_{max} \quad \varepsilon = 1 \quad <$$

## PROBLEM 11.21

**KNOWN:** Specifications for a water-to-water heat exchanger as shown in the schematic including the flow rate, and inlet and outlet temperatures.

**FIND:** (a) Design a heat exchanger to meet the specifications; that is, size the heat exchanger, and (b) Evaluate your design by identifying what features and configurations could be explored with your customer in order to develop more complete, detailed specifications.

**SCHEMATIC:**

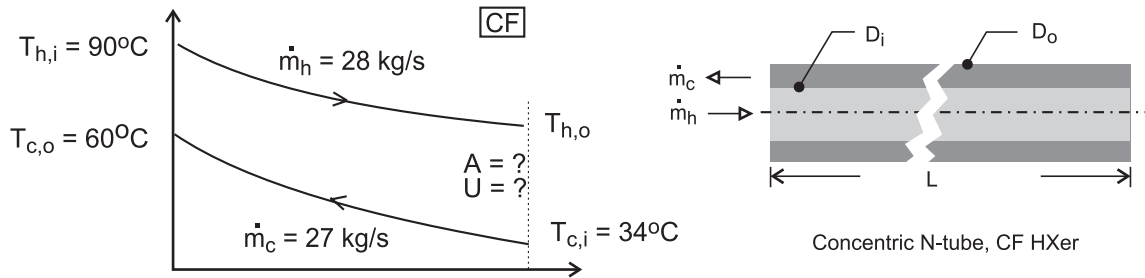

**ASSUMPTIONS:** (1) Negligible heat loss to surroundings, (2) Tube walls have negligible thermal resistance, (3) Flow is fully developed, and (4) Constant properties.

**ANALYSIS:** (a) Referring to the schematic above and using the rate equation, we can determine the value of the  $UA$  product required to satisfy the design requirements. Sizing the heat exchanger involves determining the heat transfer area,  $A$  (tube diameter, length and number), and the associated overall convection coefficient,  $U$ , such that  $U \times A$  satisfies the required  $UA$  product. Our approach has five steps: (1) *Calculate the UA product:* Select a configuration and calculate the required  $UA$  product; (2) *Estimate the area, A:* Assume a range for the overall coefficient, calculate the area and consider suitable tube diameter(s); (3) *Estimate the overall coefficient, U:* For selected tube diameter(s), use correlations to estimate hot- and cold-side convection coefficients and the overall coefficient; (4) *Evaluate first-pass design:* Check whether the  $A$  and  $U$  values ( $U \times A$ ) from Steps 2 and 3 satisfy the required  $UA$  product; if not, then (5) *Repeat the analysis:* Iterate on different values for area parameters until a satisfactory match is made,  $(U \times A) = UA$ .

To perform the analysis, *IHT* models and tools will be used for the effectiveness-NTU method relations, internal flow convection correlations, and thermophysical properties. See the Comments section for details.

*Step 1 Calculate the required UA.* For the initial design, select a concentric tube, counterflow heat exchanger. Calculate  $UA$  using the following set of equations, Eqs. 11.29a,

$$\varepsilon = \frac{1 - \exp[-NTU(1 - C_r)]}{1 - C_r \exp[-NTU(1 - C_r)]} \quad (1)$$

$$NTU = UA / C_{\min} \quad C_r = C_{\min} / C_{\max} \quad (2,3)$$

$$\varepsilon = q / q_{\max} \quad q_{\max} = C_{\min} (T_{h,i} - T_{c,i}) \quad (4,5)$$

where  $C = \dot{m} c_p$ , and  $c_p$  is evaluated at the average mean temperature of the fluid,  $\bar{T}_m = (T_{m,i} + T_{m,o})/2$ . Substituting numerical values, find

$$\varepsilon = 0.464 \quad NTU = 0.8523 \quad q = 2.934 \times 10^6 \text{ W} \quad T_{h,o} = 65.0^\circ\text{C}$$

Continued ...

**PROBLEM 11.21 (Cont.)**

$$UA = 9.62 \times 10^4 \text{ W/K} \quad <$$

*Step 2 Estimate the area, A.* From Table 11.2, the typical range of U for water-to-water exchangers is 850 – 1700 W/m<sup>2</sup>·K. With  $UA = 9.619 \times 10^4 \text{ W/K}$ , the range for A is 57 – 113 m<sup>2</sup>, where

$$A = \pi D_i LN \quad (6)$$

where L and N are the length and number of tubes, respectively. Consider these values of D<sub>i</sub> with L = 10 m to describe the exchanger:

Case	D <sub>i</sub> (mm)	L (m)	N	A (m <sup>2</sup> )
1	25	10	73-146	57-113
2	50	10	36-72	57-113
3	75	10	24-48	57-113

*Step 3 Estimate the overall coefficient, U.* With the inner (hot) and outer (cold) fluids in the concentric tube arrangement, the overall coefficient is

$$1/U = 1/\bar{h}_i + 1/\bar{h}_o \quad (7)$$

and the  $\bar{h}$  are estimated using the Dittus-Boelter correlation assuming fully developed turbulent flow.

*Coefficient, hot side,  $\bar{h}_i$ .* For flow in the inner tube,

$$\text{Re}_{D_i} = \frac{4 \dot{m}_{h,i}}{\pi D_i \mu_h} \quad \dot{m}_h = \dot{m}_{hi} \cdot N \quad (8,9)$$

and the correlation, Eq. 8.60 with n = 0.3, is

$$\frac{\bar{h}_i}{k} = \frac{\bar{h}_i D_i}{k} = 0.037 \text{Re}_{D_i}^{4/5} \text{Pr}^{0.3} \quad (10)$$

where properties are evaluated at the average mean temperature,  $\bar{T}_h = (T_{hi} + T_{ho})/2$ .

*Coefficient, cold side,  $\bar{h}_o$ .* For flow in the annular space,  $D_o - D_i$ , the above relations apply where the characteristic dimension is the hydraulic diameter,

$$D_{h,o} = 4 A_{c,o} / P_o \quad A_{c,o} = \pi (D_o^2 - D_i^2) / 4 \quad P_o = \pi (D_o + D_i) \quad (11-13)$$

To determine the outer diameter D<sub>o</sub>, require that the inner and outer fluid flow areas are the same, that is,

$$A_{c,i} = A_{c,o} \quad \pi D_i^2 / 4 = \pi (D_o^2 - D_i^2) / 4 \quad (14,15)$$

*Summary of the convection coefficient calculations.* The results of the analysis with L = 10 m are summarized below.

Continued ...

### PROBLEM 11.21 (Cont.)

Case	$D_i$ (mm)	N	A ( $m^2$ )	$\bar{h}_i$ ( $W/m^2 \cdot K$ )	$\bar{h}_o$ ( $W/m^2 \cdot K$ )	U ( $W/m^2 \cdot K$ )	$U \times A$ W/K
1a	25	73	57	4795	4877	2418	$1.39 \times 10^5$
2a	50	36	57	2424	2465	1222	$6.91 \times 10^4$
3a	75	24	57	1616	1644	814	$4.61 \times 10^4$

For all these cases, the Reynolds numbers are above 10,000 and turbulent flow occurs.

*Step 4 Evaluate first-pass design.* The required UA product value determined in step 1 is  $UA = 9.62 \times 10^4$  W/K. By comparison with the results in the above table, note that the  $U \times A$  values for cases 1a and 2a are, respectively, larger and smaller than that required. In this first-pass design trial we have identified the range of  $D_i$  and N (with  $L = 10$  m) that could satisfy the exchanger specifications. A strategy can now be developed in *Step 5* to iterate the analysis on values for  $D_i$  and N, as well as with different L, to identify a combination that will meet specifications.

(b) What information could have been provided by the customer to simplify the analysis for design of the exchanger? Looking back at the analysis, recognize that we had to assume the exchanger configuration (type) and overall length. Will knowledge of the customer's installation provide any insight? While no consideration was given in our analysis to pumping power limitations, that would affect the flow velocities, and hence selection of tube diameter.

**COMMENTS:** The *IHT* workspace with the relations for step 3 analysis is shown below, including summary of key correlation parameters. The set of equations is quite stiff so that good initial guesses are required to make the initial solve.

```

/* Results, Step 3 - Di = 25 mm, N = 73, L = 10 m
A   Do   U   UA   Di   L   N
57.33 0.03536 2418 1.386E5 0.025 10 73
ReDi   ReDo   hDi   hDo
5.384E4 1.352E4 4795 4877 */

/* Results, Step 3 - Di = 50 mm, N = 36, L = 10 m
A   Do   U   UA   Di   L   N
56.55 0.07071 1222 6.912E4 0.05 10 36
ReDi   ReDo   hDi   hDo
5.459E4 1.371E4 2424 2465 */

/* Results, Step 3 - Di = 75 mm, N = 24, L = 10 m
A   Do   U   UA   Di   L   N
56.55 0.1061 814.8 4.608E4 0.075 10 24
ReDi   ReDo   hDi   hDo
5.459E4 1.371E4 1616 1644 */

// Input variables
//Di = 0.050
Di = 0.025
//Di = 0.075
//N = 36
N = 73
//N = 24
L = 10
mdoth = 28
Thi_C = 90
Tho_C = 65.0 // From Step 1
mdotc = 27
Tci_C = 34
Tco_C = 60

```

Continued ...

## PROBLEM 11.21 (Cont.)

### // Flow rate and number of tubes, inside parameters (hot)

```
mdot = N * um * ρi * Ac  
Ac = π * Di2 / 4  
1 / U = 1 / hi + 1 / ho  
UA = U * A  
A = π * Di * L * N
```

### // Flow rate, outside parameters (cold)

```
mdot = ρo * Ao * uo * N  
Ao = Ac // Make cross-sectional areas of equal size  
Ao = π * (Do2 - Di2) / 4  
Dh = 4 * Ao / P // hydraulic diameter  
P = π * (Di + Do) // wetted perimeter of the annular space
```

### // Inside coefficient, hot fluid

```
Nui = NuD_bar_IF_T_FD(Rei, Pri, n) // Eq 8.60  
n = 0.3 // n = 0.4 or 0.3 for Ts > Tm or Ts < Tm  
Nui = hi * Di / ki  
Rei = um * Di / νi  
/* Evaluate properties at the fluid average mean temperature, Tm. */  
Tm = Tfluid_avg(Th, Tc)  
//Tm = 310
```

### // Outside coefficient, cold fluid

```
Nuo = NuD_bar_IF_T_FD(Reo, Pro, nn) // Eq 8.60  
nn = 0.4 // n = 0.4 or 0.3 for Ts > Tm or Ts < Tm  
Nuo = ho * Dh / ko  
Reo = uo * Dh / νo  
/* Evaluate properties at the fluid average mean temperature, Tm. */  
Tm = Tfluid_avg(Tc, Th)  
//Tm = 310
```

### // Water property functions :T dependence, From Table A.6

```
// Units: T(K), p(bars);  
x = 0 // Quality (0=sat liquid or 1=sat vapor)  
ρi = ρTx("Water", Tm, x) // Density, kg/m3  
νi = νTx("Water", Tm, x) // Kinematic viscosity, m2/s  
ki = kTx("Water", Tm, x) // Thermal conductivity, W/m·K  
Pri = PrTx("Water", Tm, x) // Prandtl number  
ρo = ρTx("Water", Tm, x) // Density, kg/m3  
νo = νTx("Water", Tm, x) // Kinematic viscosity, m2/s  
ko = kTx("Water", Tm, x) // Thermal conductivity, W/m·K  
Pro = PrTx("Water", Tm, x) //Prandtl number
```

### // Conversions

```
Th_C = Th - 273  
To_C = To - 273  
Tc_C = Tc - 273  
Tco_C = Tco - 273
```

## PROBLEM 11.22

**KNOWN:** Inlet and outlet temperatures for a shell-and-tube heat exchanger with 10 tubes making eight passes. Heat transfer coefficient for oil flowing in shell. Mass flow rate of water in tubes. Tube diameter.

**FIND:** Oil flow rate required to achieve specified outlet temperature. Tube length required to achieve specified water heating.

**SCHEMATIC:**

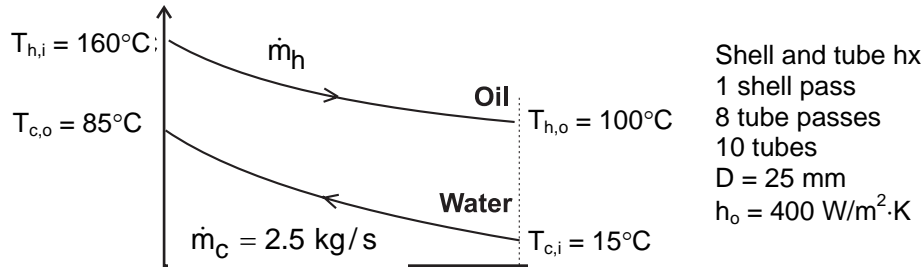

**ASSUMPTIONS:** (1) Negligible heat loss to the surroundings, (2) Constant properties, (3) Negligible tube wall thermal resistance and fouling effects, (4) Fully developed water flow in tubes.

**PROPERTIES:** Table A.5, unused engine oil: ( $\bar{T}_h = 130^\circ\text{C}$ ):  $c_p = 2350 \text{ J/kg}\cdot\text{K}$ . Table A.6, water ( $\bar{T}_c = 50^\circ\text{C}$ ):  $c_p = 4181 \text{ J/kg}\cdot\text{K}$ ,  $\mu = 548 \times 10^{-6} \text{ N}\cdot\text{s/m}^2$ ,  $k = 0.643 \text{ W/m}\cdot\text{K}$ ,  $\text{Pr} = 3.56$ .

**ANALYSIS:** From the overall energy balance, Eq. 11.7b, the heat transfer required of the exchanger is

$$q = \dot{m}_c c_{p,c} (T_{c,o} - T_{c,i}) = 2.5 \text{ kg/s} \times 4181 \text{ J/kg}\cdot\text{K} (85 - 15)^\circ\text{C} = 7.317 \times 10^5 \text{ W}$$

Hence from Eq. 11.6b,

$$\dot{m}_h = \frac{q}{c_{p,h} (T_{h,i} - T_{h,o})} = \frac{7.317 \times 10^5 \text{ W}}{2350 \text{ J/kg}\cdot\text{K} (160 - 100)^\circ\text{C}} = 5.19 \text{ kg/s} \quad <$$

The required tube length may be obtained using the  $\epsilon$ -NTU method. We first calculate the heat capacity rates,  $C_h = \dot{m}_h c_{p,h} = 12,195 \text{ W/K}$ ,  $C_c = \dot{m}_c c_{p,c} = 10,453 \text{ W/K}$ . Thus,  $C_{\min} = C_c$ , and  $C_r = C_{\min}/C_{\max} = 0.857$ . Then from Eq. 11.21,

$$\epsilon = \frac{T_{c,o} - T_{c,i}}{T_{h,i} - T_{c,i}} = \frac{(85 - 15)^\circ\text{C}}{(160 - 15)^\circ\text{C}} = 0.483$$

Using Eqs. 11.30b,c for one shell pass and an even number of tube passes, we find

Continued...

**PROBLEM 11.22 (Cont.)**

$$E = \frac{2/\varepsilon - (1 + C_r)}{(1 + C_r^2)^{1/2}} = \frac{2/0.483 - (1 + 0.857)}{(1 + 0.857^2)^{1/2}} = 1.74$$

$$\text{NTU} = -(1 + C_r^2)^{-1/2} \ln\left(\frac{E - 1}{E + 1}\right) = -(1 + 0.857^2)^{-1/2} \ln\left(\frac{1.74 - 1}{1.74 + 1}\right) = 0.997$$

Thus  $UA = \text{NTU} \times C_{\min} = 10,420 \text{ W/K}$ . To find the required tube length, we must know the heat transfer coefficients for the water flow. We calculate the Reynolds number, with  $\dot{m}_1 = \dot{m}_c / N = 0.25 \text{ kg/s}$  defined as the water flow rate per tube, Eq. 8.6 yields

$$\text{Re}_D = \frac{4\dot{m}_1}{\pi D \mu_c} = \frac{4 \times 0.25 \text{ kg/s}}{\pi (0.025 \text{ m}) 548 \times 10^{-6} \text{ N} \cdot \text{s/m}^2} = 23,234$$

Hence the flow is turbulent, and from Eq. 8.60,

$$\text{Nu}_D = 0.023 \text{Re}_D^{4/5} \text{Pr}^{0.4} = 0.023(23,234)^{4/5} (3.56)^{0.4} = 119$$

and

$$h_c = \frac{k_c}{D} \text{Nu}_D = \frac{0.643 \text{ W/m} \cdot \text{K}}{0.025 \text{ m}} 119 = 3060 \text{ W/m}^2 \cdot \text{K}$$

Hence  $U = [1/h_c + 1/h_h]^{-1} = 354 \text{ W/m}^2 \cdot \text{K}$  and we can find the required tube length from

$$L = \frac{UA}{UN\pi D} = \frac{10,420 \text{ W/K}}{354 \text{ W/m}^2 \cdot \text{K} \times 10 \times \pi \times 0.025 \text{ m}} = 37.5 \text{ m} \quad <$$

**COMMENTS:** (1) With  $L/D = 1516$ , the assumption of fully developed conditions throughout the tube is justified. (2) With eight passes, the shell length is approximately  $L/8 = 4.7 \text{ m}$ .

### PROBLEM 11.23

**KNOWN:** Counterflow concentric tube heat exchanger.

**FIND:** (a) Total heat transfer rate and outlet temperature of the water and (b) Required length.

**SCHEMATIC:**

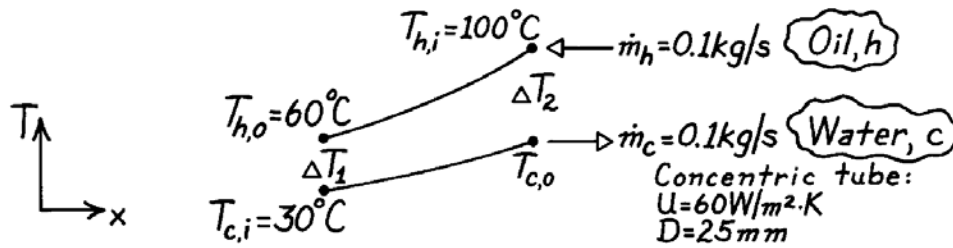

**ASSUMPTIONS:** (1) Negligible heat loss to surroundings, (2) Negligible thermal resistance due to tube wall thickness.

**PROPERTIES:** (given):

	$\rho$ (kg/m <sup>3</sup> )	$c_p$ (J/kg·K)	$\nu$ (m <sup>2</sup> /s)	$k$ (W/m·K)	Pr
Water	1000	4200	$7 \times 10^{-7}$	0.64	4.7
Oil	800	1900	$1 \times 10^{-5}$	0.134	140

**ANALYSIS:** (a) With the outlet temperature,  $T_{c,o} = 60^\circ\text{C}$ , from an overall energy balance on the hot (oil) fluid, find

$$q = \dot{m}_h c_h (T_{h,i} - T_{h,o}) = 0.1 \text{ kg/s} \times 1900 \text{ J/kg} \cdot \text{K} (100 - 60)^\circ\text{C} = 7600 \text{ W.} \quad <$$

From an energy balance on the cold (water) fluid, find

$$T_{c,o} = T_{c,i} + q / \dot{m}_c c_c = 30^\circ\text{C} + 7600 \text{ W} / 0.1 \text{ kg/s} \times 4200 \text{ J/kg} \cdot \text{K} = 48.1^\circ\text{C.} \quad <$$

(b) Using the LMTD method, the length of the CF heat exchanger follows from

$$q = UA\Delta T_{\text{lm,CF}} = U(\pi DL)\Delta T_{\text{lm,CF}} \quad L = q / U(\pi D)\Delta T_{\text{lm,CF}}$$

where

$$\Delta T_{\text{lm,CF}} = \frac{\Delta T_1 - \Delta T_2}{\ln(\Delta T_1 / \Delta T_2)} = \frac{(60 - 30)^\circ\text{C} - (100 - 48.1)^\circ\text{C}}{\ln(30 / 51.9)} = 40.0^\circ\text{C}$$

$$L = 7600 \text{ W} / 60 \text{ W/m}^2 \cdot \text{K} (\pi \times 0.025 \text{ m}) \times 40.0^\circ\text{C} = 40.3 \text{ m.} \quad <$$

**COMMENTS:** Using the  $\epsilon$ -NTU method, find  $C_{\min} = C_h = 190 \text{ W/K}$  and  $C_{\max} = C_c = 420 \text{ W/K}$ . Hence

$$q_{\max} = C_{\min} (T_{h,i} - T_{c,i}) = 190 \text{ W/K} (100 - 30) \text{ K} = 13,300 \text{ W}$$

and  $\epsilon = q/q_{\max} = 0.571$ . With  $C_r = C_{\min}/C_{\max} = 0.452$  and using Eq. 11.29b,

$$\text{NTU} = \frac{UA}{C_{\min}} = \frac{1}{C_r - 1} \ln\left(\frac{\epsilon - 1}{\epsilon C_r - 1}\right) = \frac{1}{0.452 - 1} \ln\left(\frac{0.571 - 1}{0.571 \times 0.452 - 1}\right) = 1.00$$

so that with  $A = \pi DL$ , find  $L = 40.3 \text{ m}$ .



### PROBLEM 11.24

**KNOWN:** Counterflow, concentric tube heat exchanger undergoing test after service for an extended period of time; surface area of  $5 \text{ m}^2$  and design value for the overall heat transfer coefficient of  $U_d = 38 \text{ W/m}^2 \cdot \text{K}$ .

**FIND:** Fouling factor, if any, based upon the test results of engine oil flowing at  $0.1 \text{ kg/s}$  cooled from  $110^\circ\text{C}$  to  $66^\circ\text{C}$  by water supplied at  $25^\circ\text{C}$  and a flow rate of  $0.2 \text{ kg/s}$ .

**SCHEMATIC:**

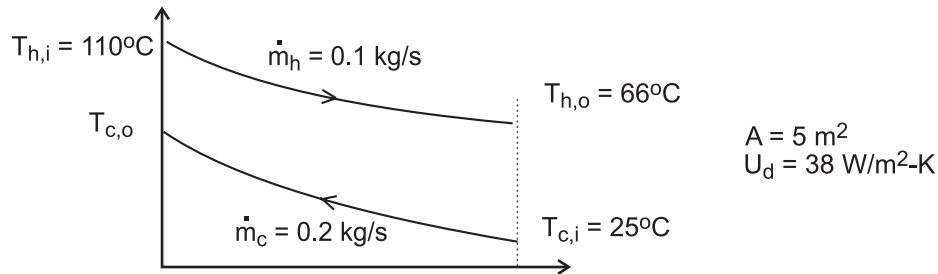

**ASSUMPTIONS:** (1) Steady-state conditions, (2) Negligible losses to the surroundings, (3) Constant properties.

**PROPERTIES:** Table A-5, Engine oil ( $\bar{T}_h = 361 \text{ K}$ ):  $c = 2166 \text{ J/kg}\cdot\text{K}$ ; Table A-6, Water ( $\bar{T}_c = 304 \text{ K}$ , assuming  $T_{c,o} = 36^\circ\text{C}$ ):  $c = 4178 \text{ J/kg}\cdot\text{K}$ .

**ANALYSIS:** For the CF conditions shown in the Schematic, find the heat rate,  $q$ , from an energy balance on the hot fluid (oil); the cold fluid outlet temperature,  $T_{c,o}$ , from an energy balance on the cold fluid (water); the overall coefficient  $U$  from the rate equation; and a fouling factor,  $R$ , by comparison with the design value,  $U_d$ .

*Energy balance on hot fluid*

$$q = \dot{m}_h c_h (T_{h,i} - T_{h,o}) = 0.1 \text{ kg/s} \times 2166 \text{ J/kg}\cdot\text{K} (110 - 66) \text{ K} = 9530 \text{ W}$$

*Energy balance on the cold fluid*

$$q = \dot{m}_c c_c (T_{c,o} - T_{c,i}), \quad \text{find } T_{c,o} = 36.4^\circ\text{C}$$

*Rate equation*

$$q = UA \Delta T_{\ln,CF}$$

$$\Delta T_{\ln,CF} = \frac{(T_{h,i} - T_{c,o}) - (T_{h,o} - T_{c,i})}{\ln\left[\frac{(T_{h,i} - T_{c,o})}{(T_{h,o} - T_{c,i})}\right]} = \frac{(110 - 36.4)^\circ\text{C} - (66 - 25)^\circ\text{C}}{\ln[73.6/41.0]} = 55.7^\circ\text{C}$$

$$9530 \text{ W} = U \times 5 \text{ m}^2 \times 55.7^\circ\text{C}$$

$$U = 34.2 \text{ W/m}^2 \cdot \text{K}$$

*Overall resistance including fouling factor*

$$U = 1/[1/U_d + R_f']$$

$$34.2 \text{ W/m}^2 \cdot \text{K} = 1/[1/38 \text{ W/m}^2 \cdot \text{K} + R_f']$$

$$R_f' = 0.0029 \text{ m}^2 \cdot \text{K/W}$$

<

### PROBLEM 11.25

**KNOWN:** Flow rates and inlet temperatures for automobile radiator configured as a cross-flow heat exchanger with both fluids unmixed. Overall heat transfer coefficient.

**FIND:** (a) Area required to achieve hot fluid (water) outlet temperature,  $T_{h,o} = 330$  K, and (b) Outlet temperatures,  $T_{h,o}$  and  $T_{c,o}$ , as a function of the overall coefficient for the range,  $200 \leq U \leq 400$  W/m<sup>2</sup>·K with the surface area  $A$  found in part (a) with all other heat transfer conditions remaining the same as for part (a).

**SCHEMATIC:**

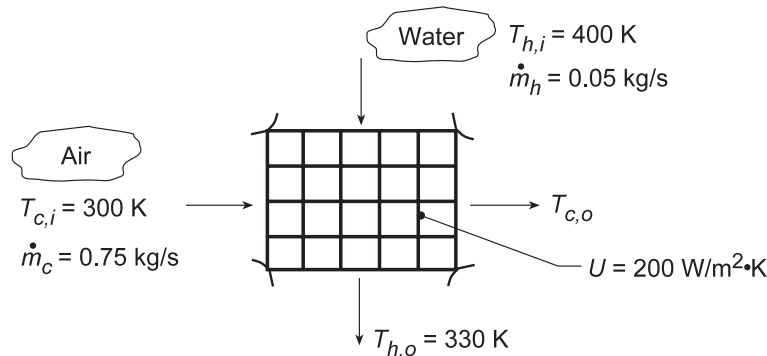

**ASSUMPTIONS:** (1) Negligible heat loss to surroundings, (2) Constant properties.

**PROPERTIES:** Table A.6, Water ( $\bar{T}_h = 365$  K):  $c_{p,h} = 4209$  J/kg·K; Table A.4, Air ( $\bar{T}_c \approx 310$  K):  $c_{p,c} = 1007$  J/kg·K.

**ANALYSIS:** (a) The required heat transfer rate is

$$q = \dot{m}_h c_{p,h} (T_{h,i} - T_{h,o}) = 0.05 \text{ kg/s} (4209 \text{ J/kg} \cdot \text{K}) 70 \text{ K} = 14,732 \text{ W} .$$

Using the  $\varepsilon$ -NTU method,

$$C_{\min} = C_h = 210.45 \text{ W/K} \quad C_{\max} = C_c = 755.25 \text{ W/K} .$$

Hence,  $C_{\min}/C_{\max} = 0.279$  and

$$q_{\max} = C_{\min} (T_{h,i} - T_{c,i}) = 210.45 \text{ W/K} (100 \text{ K}) = 21,045 \text{ W}$$

$$\varepsilon = q/q_{\max} = 14,732 \text{ W}/21,045 \text{ W} = 0.700 .$$

Figure 11.14 yields  $NTU \approx 1.5$ , hence,

$$A = NTU (C_{\min}/U) = 1.5 \times 210.45 \text{ W/K} / (200 \text{ W/m}^2 \cdot \text{K}) = 1.58 \text{ m}^2 . \quad <$$

(b) Using the *IHT Heat Exchanger Tool* for *Cross-flow with both fluids unmixed* arrangement and the *Properties Tool* for *Air* and *Water*, a model was generated to solve part (a) evaluating the efficiency using Eq. 11.32. The following results were obtained:

$$A = 1.516 \text{ m}^2 \quad NTU = 1.441 \quad T_{c,o} = 319.5 \text{ K}$$

Using the model but assigning  $A = 1.516$  m<sup>2</sup>, the outlet temperature  $T_{h,o}$  and  $T_{c,o}$  were calculated as a function of  $U$  and the results plotted below.

Continued...

## PROBLEM 11.25 (Cont.)

With a higher  $U$ , the outlet temperature of the hot fluid (water) decreases. A benefit is enhanced heat removal from the engine block and a cooler operating temperature. If it is desired to cool the engine with water at 330 K, the heat exchanger surface area and, hence its volume in the engine component could be reduced.

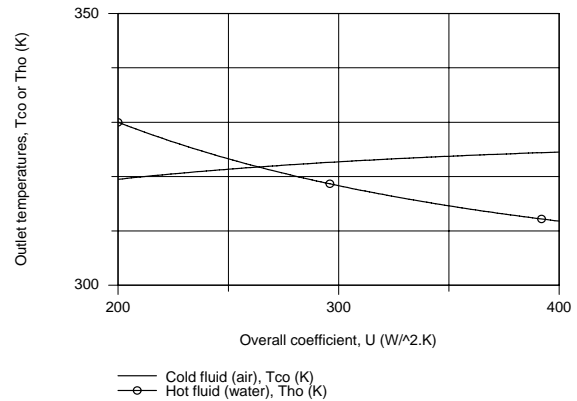

**COMMENTS:** (1) For the results of part (a), the air outlet temperature is

$$T_{c,o} = T_{c,i} + q/C_c = 300 \text{ K} + (14,732 \text{ W}/755.25 \text{ W/K}) = 319.5 \text{ K} .$$

(2) The IHT workspace with the model to generate the above plot is shown below. Note that it is necessary to enter the overall energy balances on the fluids from the keyboard.

```

// Heat Exchanger Tool - Cross-flow with both fluids unmixed:
// For the cross-flow, single-pass heat exchanger with both fluids unmixed,
eps = 1 - exp((1 / Cr) * (NTU^0.22) * (exp(-Cr * NTU^0.78) - 1)) // Eq 11.32
// where the heat-capacity ratio is
Cr = Cmin / Cmax
// and the number of transfer units, NTU, is
NTU = U * A / Cmin // Eq 11.24
// The effectiveness is defined as
eps = q / qmax
qmax = Cmin * (Thi - Tci) // Eq 11.18, 11.19
// See Tables 11.3 and 11.4 and Fig 11.14
// Overall Energy Balances on Fluids:
q = mdoth * cph * (Thi - Tho)
q = mdotc * cpc * (Tco - Tci)
// Assigned Variables:
Cmin = Ch // Capacity rate, minimum fluid, W/K
Ch = mdoth * cph // Capacity rate, hot fluid, W/K
mdoth = 0.05 // Flow rate, hot fluid, kg/s
Thi = 400 // Inlet temperature, hot fluid, K
Tho = 330 // Outlet temperature, hot fluid, K; specified for part (a)
Cmax = Cc // Capacity rate, maximum fluid, W/K
Cc = mdotc * cpc // Capacity rate, cold fluid, W/K
mdotc = 0.75 // Flow rate, cold fluid, kg/s
Tci = 300 // Inlet temperature, cold fluid, K
U = 200 // Overall coefficient, W/m^2.K
// Properties Tool - Water (h)
// Water property functions :T dependence, From Table A.6
// Units: T(K), p(bars);
xh = 0 // Quality (0=sat liquid or 1=sat vapor)
rho_h = rho_Tx("Water",Tmh,xh) // Density, kg/m^3
cph = cp_Tx("Water",Tmh,xh) // Specific heat, J/kg.K
Tmh = Tfluid_avg(Thi,Tho)
// Properties Tool - Air(c)
// Air property functions : From Table A.4
// Units: T(K); 1 atm pressure
rho_c = rho_T("Air",Tmc) // Density, kg/m^3
cpc = cp_T("Air",Tmc) // Specific heat, J/kg.K
Tmc = Tfluid_avg(Tci,Tco)

```

## PROBLEM 11.26

**KNOWN:** Flowrates and inlet temperatures of a cross-flow heat exchanger with both fluids unmixed. Total surface area and overall heat transfer coefficient for clean surfaces. Fouling resistance associated with extended operation.

**FIND:** (a) Fluid outlet temperatures, (b) Effect of fouling, (c) Effect of UA on air outlet temperature.

**SCHEMATIC:**

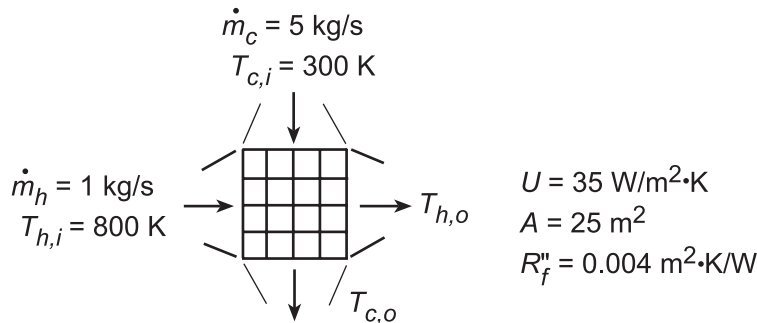

**ASSUMPTIONS:** (1) Negligible heat loss to surroundings, (2) Constant properties, (3) Negligible tube wall resistance.

**PROPERTIES:** Air and gas (given):  $c_p = 1040 \text{ J/kg}\cdot\text{K}$ .

**ANALYSIS:** (a) With  $C_{\min} = C_h = 1 \text{ kg/s} \times 1040 \text{ J/kg}\cdot\text{K} = 1040 \text{ W/K}$  and  $C_{\max} = C_c = 5 \text{ kg/s} \times 1040 \text{ J/kg}\cdot\text{K} = 5200 \text{ W/K}$ ,  $C_{\min}/C_{\max} = 0.2$ . Hence,  $\text{NTU} = UA/C_{\min} = 35 \text{ W/m}^2\cdot\text{K}(25 \text{ m}^2)/1040 \text{ W/K} = 0.841$  and Fig. 11.14 yields  $\varepsilon \approx 0.57$ . With  $C_{\min}(T_{h,i} - T_{c,i}) = 1040 \text{ W/K}(500 \text{ K}) = 520,000 \text{ W} = q_{\max}$ , Eqs. (11.20) and (11.21) yield

$$T_{h,o} = T_{h,i} - \varepsilon q_{\max} / C_h = 800 \text{ K} - 0.57(520,000 \text{ W}) / 1040 \text{ W/K} = 515 \text{ K} \quad <$$

$$T_{c,o} = T_{c,i} + \varepsilon q_{\max} / C_c = 300 \text{ K} + 0.57(520,000 \text{ W}) / 5200 \text{ W/K} = 357 \text{ K} \quad <$$

(b) With fouling, the overall heat transfer coefficient is reduced to

$$U_f = \left( U^{-1} + R_f'' \right)^{-1} = \left[ (0.029 + 0.004) \text{ m}^2 \cdot \text{K/W} \right]^{-1} = 30.7 \text{ W/m}^2 \cdot \text{K}$$

This 12% reduction in performance is large enough to justify cleaning of the tubes. <

(c) Using the *Heat Exchangers* option from the IHT Toolpad to explore the effect of UA, we obtain the following result.

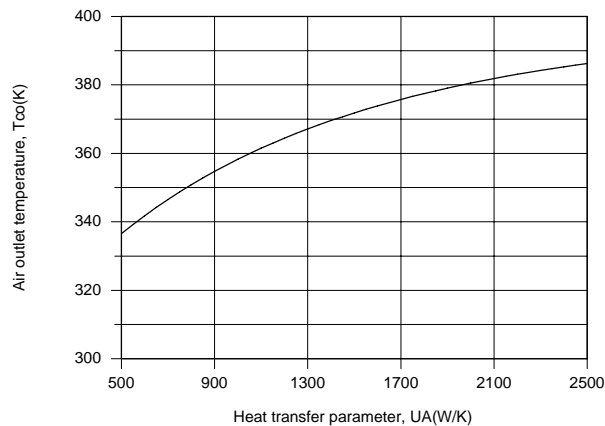

The heat rate, and hence the air outlet temperature, increases with increasing UA, with  $T_{c,o}$  approaching a maximum outlet temperature of 400 K as  $UA \rightarrow \infty$  and  $\varepsilon \rightarrow 1$ .

**COMMENTS:** Note that, for conditions of part (a), Eq. 11.32 yields a value of  $\varepsilon = 0.538$ , which reveals the level of approximation associated with reading  $\varepsilon$  from Fig. 11.14.

## PROBLEM 11.27

**KNOWN:** Cooling milk from a dairy operation to a safe-to-store temperature,  $T_{h,o} \leq 13^\circ\text{C}$ , using ground water in a counterflow concentric tube heat exchanger with a 50-mm diameter inner pipe and overall heat transfer coefficient of  $1000 \text{ W/m}^2 \cdot \text{K}$ .

**FIND:** (a) The UA product required for the chilling process and the length  $L$  of the exchanger, (b) The outlet temperature of the ground water, and (c) the milk outlet temperatures for the cases when the water flow rate is halved and doubled, using the UA product found in part (a)

**SCHEMATIC:**

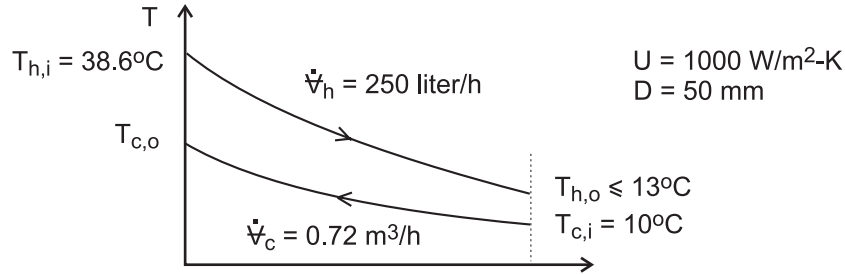

**ASSUMPTIONS:** (1) Steady-state conditions, (2) Negligible heat loss to surroundings, and (3) Constant properties.

**PROPERTIES:** Table A-6, Water ( $\bar{T}_c = 287 \text{ K}$ , assume  $T_{c,o} = 18^\circ\text{C}$ ):  $\rho = 1000 \text{ kg/m}^3$ ,

$c_p = 4187 \text{ J/kg} \cdot \text{K}$ ; Milk (given):  $\rho = 1030 \text{ kg/m}^3$ ,  $c_p = 3860 \text{ J/kg} \cdot \text{K}$ .

**ANALYSIS:** (a) Using the effectiveness-NTU method, determine the capacity rates and the minimum fluid.

*Hot fluid, milk:*

$$\dot{m}_h = \rho_h \dot{V}_h = 1030 \text{ kg/m}^3 \times 250 \text{ liter/h} \times 10^{-3} \text{ m}^3/\text{liter} \times 1 \text{ h}/3600 \text{ s} = 0.0715 \text{ kg/s}$$

$$C_h = \dot{m}_h c_h = 0.0715 \text{ kg/s} \times 3860 \text{ J/kg} \cdot \text{K} = 276 \text{ W/K}$$

*Cold fluid, water:*

$$C_c = \dot{m}_c c_c = 1000 \text{ kg/m}^3 \times (0.72/3600 \text{ m}^3/\text{s}) \times 4187 \text{ J/kg} \cdot \text{K} = 837 \text{ W/K}$$

It follows that  $C_{\min} = C_h$ . The effectiveness of the exchanger from Eq. 11.20 is

$$\varepsilon = \frac{q}{q_{\max}} = \frac{C_h (T_{h,i} - T_{h,o})}{C_{\min} (T_{h,i} - T_{c,i})} = \frac{(38.6 - 13)\text{K}}{(38.6 - 10)\text{K}} = 0.895 \quad (1)$$

The NTU can be calculated from Eq. 11.29b, where  $C_r = C_{\min}/C_{\max} = 0.330$ ,

$$\text{NTU} = \frac{1}{C_r - 1} \ln \left( \frac{\varepsilon - 1}{\varepsilon C_r - 1} \right) \quad (2)$$

$$\text{NTU} = \frac{1}{0.330 - 1} \ln \left( \frac{0.895 - 1}{0.895 \times 0.330 - 1} \right) = 2.842$$

Continued ...

### PROBLEM 11.27 (Cont.)

From Eq. 11.24, find UA

$$[UA] = NTU \cdot C_{\min} = 2.842 \times 276 \text{ W/K} = 785 \text{ W/K} \quad <$$

and the exchanger tube length with  $A = \pi DL$  is

$$L = [UA] / \pi DU = 785 \text{ W/K} / \pi 0.050 \text{ m} \times 1000 \text{ W/m}^2 \cdot \text{K} = 5.0 \text{ m} \quad <$$

(b) The water outlet temperature,  $T_{c,o}$ , can be calculated from the heat rates,

$$C_h (T_{h,i} - T_{h,o}) = C_c (T_{c,o} - T_{c,i}) \quad (3)$$

$$276 \text{ W/K} (38.6 - 13) \text{K} = 837 \text{ W/K} (T_{c,o} - 10) \text{K}$$

$$T_{c,o} = 18.4^\circ \text{C} \quad <$$

(c) Using the foregoing Eqs. (1 - 3) in the *IHT* workspace, the hot fluid (milk) outlet temperatures are evaluated with  $UA = 785 \text{ W/K}$  for different water flow rates. The results, including the hot fluid outlet temperatures, are compared to the base case, part (a).

Case	$C_c$ (W/K)	$T_{c,o}$ ( $^\circ\text{C}$ )	$T_{h,o}$ ( $^\circ\text{C}$ )
1, halved flow rate	419	14.9	25.6
Base, part (a)	837	13	18.4
2, doubled flow rate	1675	12.3	14.3

**COMMENTS:** (1) From the results table in part (c), note that if the water flow rate is halved, the milk will not be properly chilled, since  $T_{c,o} = 14.9^\circ\text{C} > 13^\circ\text{C}$ . Doubling the water flow rate reduces the outlet milk temperature by less than  $1^\circ\text{C}$ .

(2) From the results table, note that the water outlet temperature changes are substantially larger than those of the milk with changes in the water flow rate. Why is this so? What operational advantage is achieved using the heat exchanger under the present conditions?

(3) The water thermophysical properties were evaluated at the average cold fluid temperature,  $\bar{T}_c = (T_{c,i} + T_{c,o})/2$ . We assumed an outlet temperature of  $18^\circ\text{C}$ , which as the results show, was a good choice. Because the water properties are not highly temperature dependent, it was acceptable to use the same values for the calculations of part (c). You could, of course, use the properties function in *IHT* that will automatically use the appropriate values.

(4) The value of the overall heat transfer coefficient,  $U$ , will change as the mass flow rate is varied. The answer to part (c) would be different if this variation is accounted for.

## PROBLEM 11.28

**KNOWN:** Flow rate, inlet temperatures and overall heat transfer coefficient for a regenerator. Desired regenerator effectiveness. Cost of natural gas.

**FIND:** (a) Heat transfer area required for regenerator and corresponding heat recovery rate and outlet temperatures, (b) Annual energy and fuel cost savings.

**SCHEMATIC:**

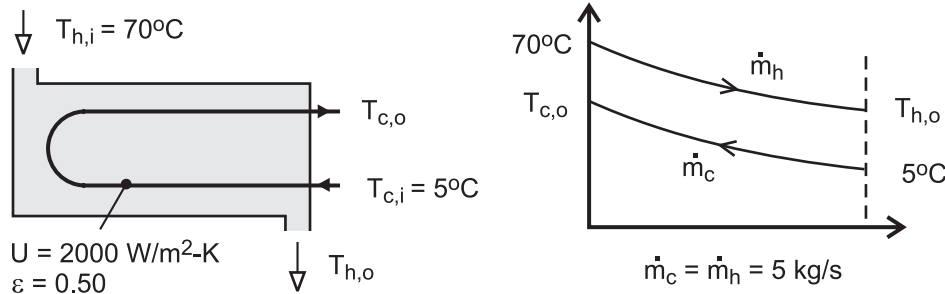

**ASSUMPTIONS:** (a) Negligible heat loss to surroundings, (b) Constant properties.

**PROPERTIES:** Problem 11.27, milk:  $c_p = 3860 \text{ J/kg}\cdot\text{K}$ .

**ANALYSIS:** (a) With  $C_r = 1$  and  $\varepsilon = 0.50$  for one shell and two tube passes, Eq. 11.30c yields  $E = 1.414$ . With  $C_{\min} = 5 \text{ kg/s} \times 3860 \text{ J/kg}\cdot\text{K} = 19,300 \text{ W/K}$ , Eq. 11.30b then yields

$$A = -\frac{C_{\min}}{U} \frac{\ln[(E-1)/(E+1)]}{(1+C_r^2)^{1/2}} = -\frac{19,300 \text{ W/K}}{2000 \text{ W/m}^2 \cdot \text{K}} \frac{\ln(0.171)}{1.414} = 12.03 \text{ m}^2 \quad <$$

With  $\varepsilon = 0.50$ , the heat recovery rate is then

$$q = \varepsilon C_{\min} (T_{h,i} - T_{c,i}) = 627,000 \text{ W} \quad <$$

and the outlet temperatures are

$$T_{c,o} = T_{c,i} + \frac{q}{C_c} = 5^\circ\text{C} + \frac{627,000 \text{ W}}{19,300 \text{ W/K}} = 37.5^\circ\text{C} \quad <$$

$$T_{h,o} = T_{h,i} - \frac{q}{C_h} = 70^\circ\text{C} - \frac{627,000 \text{ W}}{19,300 \text{ W/K}} = 37.5^\circ\text{C} \quad <$$

(b) The amount of energy recovered for continuous operation over 365 days is

$$\Delta E = 627,000 \text{ W} \times 365 \text{ d/yr} \times 24 \text{ h/d} \times 3600 \text{ s/h} = 1.98 \times 10^{13} \text{ J/yr}$$

The annual fuel savings  $S_A$  is then

$$S_A = \frac{\Delta E \times C_{\text{ng}}}{\eta} = \frac{1.98 \times 10^7 \text{ MJ/yr} \times \$0.02/\text{MJ}}{0.9} = \$440,000/\text{yr} \quad <$$

**COMMENTS:** (1) With  $C_c = C_h$ , the temperature changes are the same for the two fluids, (2) A larger effectiveness and hence a smaller value of  $A$  can be achieved with a counterflow exchanger (compare Figs. 11.11 and 11.12 for  $C_r = 1$ ), (c) The savings are significant and well worth the cost of the heat exchanger. An additional benefit is that, with  $T_{h,o}$  reduced from 70 to 37.5°C, less energy is consumed by the refrigeration system used to restore the milk temperature to 5°C.

## PROBLEM 11.29

**KNOWN:** Twin-tube counterflow heat exchanger with balanced flow rates,  $\dot{m}_h = 0.003 \text{ kg/s}$ . Cold airstream enters at 280 K and must be heated to 340 K. Maximum allowable pressure drop of cold airstream is 10 kPa.

**FIND:** (a) Tube diameter  $D$  and length  $L$  which satisfies the heat transfer and pressure drop requirements, and (b) Compute and plot the cold stream outlet temperature  $T_{c,o}$ , the heat rate  $q$ , and pressure drop  $\Delta p$  as a function of the balanced flow rate from 0.002 to 0.004 kg/s.

**SCHEMATIC:**

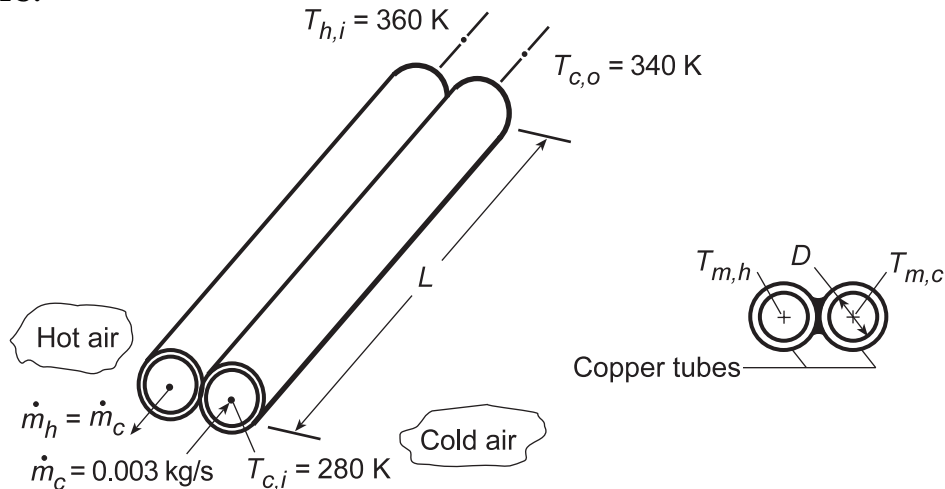

**ASSUMPTIONS:** (1) Steady-state conditions, (2) Negligible heat loss to surroundings, (3) Average pressure of the airstreams is 1 atm, (4) Tube walls act as fins with 100% efficiency, (4) Fully developed flow.

**PROPERTIES:** Table A.4, Air ( $\bar{T}_m = 310 \text{ K}$ , 1 atm):  $\rho = 1.128 \text{ kg/m}^3$ ,  $c_p = 1007 \text{ J/kg}\cdot\text{K}$ ,  $\mu = 18.93 \times 10^{-6} \text{ m}^2/\text{s}$ ,  $k = 0.0270 \text{ W/m}\cdot\text{K}$ ,  $Pr = 0.7056$ .

**ANALYSIS:** (a) The heat exchanger diameter  $D$  and length  $L$  can be specified through two analyses: (1) heat transfer based upon the effectiveness-NTU method to meet the cold air heating requirement and (2) pressure drop calculation to meet the requirement of 10 kPa. The *heat transfer analysis* begins by determining the effectiveness from Eq. 11.21, since  $C_{\min} = C_{\max}$  and  $C_r = 1$ ,

$$\varepsilon = \frac{q}{q_{\max}} = \frac{C(T_{c,o} - T_{c,i})}{C(T_{h,i} - T_{c,i})} = \frac{(340 - 280) \text{ K}}{(360 - 280) \text{ K}} = 0.750 \quad (1)$$

From Table 11.4, Eq. 11.29b for  $C_r = 1$ ,

$$NTU = \frac{\varepsilon}{1 - \varepsilon} = \frac{0.750}{1 - 0.750} = 3 \quad (2)$$

where NTU, following its definition, Eq. 11.24, is

$$NTU = \frac{\bar{U}A}{C_{\min}} \quad (3)$$

with

$$C_{\min} = \dot{m}c_p = 0.003 \text{ kg/s} \times 1007 \text{ J/kg}\cdot\text{K} = 3.021 \text{ K/W} \quad (4)$$

Continued...



**PROBLEM 11.29 (Cont.)**

and  $1/\bar{U}A$  represents the thermal resistance between the two fluids at  $T_{m,h}$  and  $T_{m,c}$  as illustrated in the above-right schematic. Since the tube walls are isothermal, it follows that

$$1/UA = 1/\bar{h}_c A + 1/\bar{h}_h A \quad (5)$$

and since the flow conditions are nearly identical  $\bar{h}_c = \bar{h}_h$  so that

$$U = 0.5\bar{h} \quad (6)$$

where the heat transfer area is

$$A = \pi DL \quad (7)$$

This is a consequence of the assumption that the walls act as fins with 100% efficiency. Hence, Eq. (3) can now be expressed as

$$3 = \frac{0.5\bar{h}(\pi DL)}{3.021 \text{ K/W}}$$

$$\bar{h}DL = 5.7697 \quad (8)$$

Assuming an average mean temperature  $\bar{T}_{m,c} = 310 \text{ K}$ , characterize the flow with

$$\text{Re}_D = \frac{4\dot{m}}{\pi D \mu} = \frac{4 \times 0.003 \text{ kg/s}}{\pi \times D \times 18.93 \times 10^{-6} \text{ m}^2/\text{s}} = \frac{201.78}{D} \quad (9)$$

and assuming the flow is both turbulent and fully developed using the Dittus-Boelter, Eq. 8.60,

$$\frac{\bar{h}D}{k} = 0.023 \text{Re}_D^{0.8} \text{Pr}^{0.4}$$

$$\bar{h}D = 0.023 \times 0.0270 \text{ W/m} \cdot \text{K} (201.78/D)^{0.8} (0.7056)^{0.4}$$

$$\bar{h}D^{1.8} = 0.0377 \quad (10)$$

Note that the heating condition has been selected ( $n = 0.4$ ) for both streams, as an estimate.

The *pressure drop* for fully developed flow, Eq. 8.22a, is

$$\Delta p = f \frac{\rho u_m^2 L}{2D} \quad (11)$$

where the mean velocity is  $u_m = \dot{m}/(\rho\pi D^2/4)$  so that

$$\Delta p = f \frac{\rho \left(4\dot{m}/\rho\pi D^2\right)^2 L}{2D} = \frac{8}{\pi^2} f \frac{\dot{m}^2 L}{\rho D^5}$$

$$\Delta p = \frac{8}{\pi^2} f \frac{(0.003 \text{ kg/s})^2 L}{(1.128 \text{ kg/m}^3) D^5} = 6.467 \times 10^{-6} f L D^{-5} \quad (12)$$

Recall that the pressure drop requirement is  $\Delta p = 10 \text{ kPa} = 10^4 \text{ N/m}^2$ , so that Eq. (12) can be rewritten as

$$f L D^{-5} = 1.546 \times 10^9 \quad (13)$$

Continued...

### PROBLEM 11.29 (Cont.)

For the Reynolds number range,  $3000 \leq \text{Re}_D \leq 5 \times 10^6$ , Eq. 8.21 provides an estimate for the friction factor,

$$f = \left[ (0.790 \ln(\text{Re}_D) - 1.64) \right]^{-2}$$

$$f = \left[ (0.790 \ln(201.78/D) - 1.64) \right]^{-2} \quad (14)$$

In the foregoing analysis, there are 4 unknowns ( $D$ ,  $L$ ,  $f$ ,  $\bar{h}$ ) and 4 equations (8, 10, 13, 14). Using the IHT workspace, find

$$D = 9.0 \text{ mm} \quad L = 3.5 \text{ m} \quad f = 0.0254 \quad \bar{h} = 183 \text{ W/m}^2 \cdot \text{K}$$

For this configuration,  $\text{Re}_D = 22,500$  so the flow is turbulent and since  $L/D = 3.5/0.0090 = 390 \gg 10$ , the fully developed assumption is reasonable.

(b) The foregoing analysis entered into the IHT workspace was used to determine  $T_{c,o}$ ,  $q$  and  $\Delta p$  as a function of the balanced flow rate,  $\dot{m}$ .

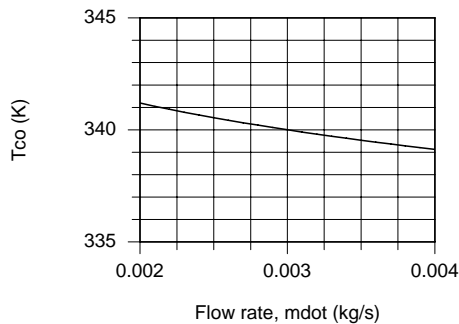
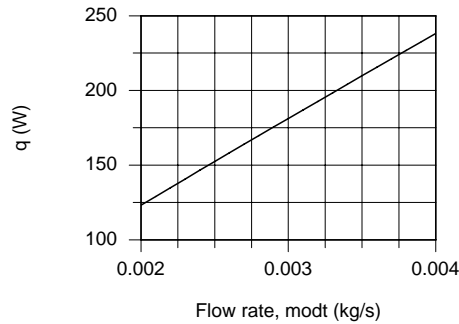
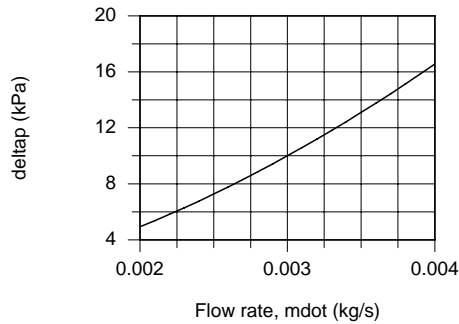

The outlet temperature of the cold air,  $T_{c,o}$ , is nearly insensitive to the flow rate. It follows that the heat rate,  $q$ , must be nearly proportional to the flow rate as can be seen in the  $q$  vs.  $\dot{m}$  plot above. The pressure drop varies with the mean velocity squared.

### PROBLEM 11.30

**KNOWN:** Dimensions and thermal conductivity of twin-tube, counterflow heat exchanger. Contact resistance between tubes. Air inlet conditions for one tube and pressure of saturated steam in other tube.

**FIND:** Air outlet temperature and condensation rate.

**SCHEMATIC:**

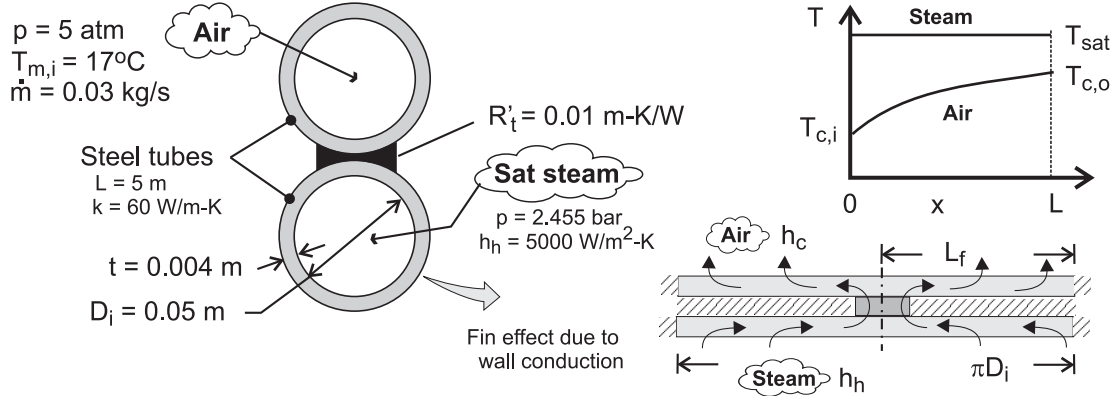

**ASSUMPTIONS:** (1) Negligible heat exchange with surroundings, (2) Fully developed air flow, (3) Negligible fouling, (4) Constant properties.

**PROPERTIES:** Table A-4, air ( $\bar{T}_c \approx 325 \text{ K}$ ,  $p = 5 \text{ atm}$ ):  $c_p = 1008 \text{ J/kg}\cdot\text{K}$ ,  $\mu = 196.4 \times 10^{-7}$

$\text{N}\cdot\text{s/m}^2$ ,  $k = 0.0281 \text{ W/m}\cdot\text{K}$ ,  $\text{Pr} = 0.703$ . Table A-6, sat. steam ( $p = 2.455 \text{ bar}$ ):  $T_{h,i} = T_{h,o} = 400 \text{ K}$ ,  $h_{fg} = 2183 \text{ kJ/kg}$ .

**ANALYSIS:** With  $C_{\max} \rightarrow \infty$ ,  $C_r = 0$  and Eqs. 11.21 and 11.35a yield

$$\varepsilon = \frac{T_{c,o} - T_{c,i}}{T_{h,i} - T_{c,i}} = 1 - \exp(-\text{NTU}) \quad (1)$$

From Eq. 11.1,

$$\frac{1}{UA} = \frac{1}{(\eta_o hA)_c} + \frac{R'_t}{L} + \frac{1}{(\eta_o hA)_h} \quad (2)$$

With  $\text{Re}_D = 4\dot{m}/\pi D_i \mu = 0.12 \text{ kg/s}/\pi(0.05\text{m})196.4 \times 10^{-7} \text{ N}\cdot\text{s/m}^2 = 38,900$ , the air flow is turbulent and the Dittus-Boelter correlation yields

$$h_c \approx h_{fD} = \left(\frac{k}{D_i}\right) 0.023 \text{Re}_D^{4/5} \text{Pr}^{0.4} = \left(\frac{0.0281 \text{ W/m}\cdot\text{K}}{0.05\text{m}}\right) 0.023(38,900)^{4/5} (0.703)^{0.4} = 52.7 \text{ W/m}^2 \cdot \text{K}$$

As shown on the inset, each tube wall may be modelled as two fins, each of length  $L_f \approx \pi D_i/2 = 0.0785\text{m}$ . The total surface area for heat transfer is  $A_t = \pi D_i L = 0.785 \text{ m}^2 = A_c$ , which is equivalent to the surface area of the fins. With  $NA_f = A_t$  from Eq. 3.102,  $\eta_o = \eta_f$ . Because the outer surface of the tube is insulated, a wall thickness of  $2t$  must be used in evaluating  $\eta_f$ . With  $m = (2h/k \times 2t)^{1/2} = (h/kt)^{1/2} = [52.7 \text{ W/m}^2 \cdot \text{K}/(60 \text{ W/m}\cdot\text{K} \times 0.004\text{m})]^{1/2} = 14.8 \text{ m}^{-1}$ ,  $L_c = L_f$  for an adiabatic tip, and  $mL_f = 1.163$ , Eq. 3.92 yields

$$\eta_f = \frac{\tanh mL_f}{mL_f} = \frac{0.821}{1.163} = 0.706 = \eta_{o,c}$$

Continued ...

### PROBLEM 11.30 (Cont.)

Similarly, for the steam tube,  $m = (h/kt)^{1/2} = [5,000 \text{ W/m}^2 \cdot \text{K}/(60 \text{ W/m} \cdot \text{K} \times 0.004\text{m})]^{1/2} = 144.3 \text{ m}^{-1}$  and  $mL_f = 11.33$ . Hence,

$$\eta_f = \frac{\tanh mL_f}{mL_f} = \frac{1.00}{11.33} = 0.088 = \eta_{o,h}$$

Substituting into Eq. (2),

$$UA = \left[ \frac{1}{0.706 \times 52.7 \times 0.785} + \frac{0.01}{5} + \frac{1}{0.088 \times 5000 \times 0.785} \right]^{-1} \frac{\text{W}}{\text{K}} = 25.6 \frac{\text{W}}{\text{K}}$$

Hence, with  $C_{\min} = (\dot{m} c_p)_c = 0.03 \text{ kg/s} \times 1008 \text{ J/kg} \cdot \text{K} = 30.2 \text{ W/K}$ ,  $NTU = UA/C_{\min} = 0.847$  and  $\varepsilon = 1 - \exp(-NTU) = 0.571$ . From Eq. (1), the air outlet temperature is then

$$T_{c,o} = T_{c,i} + \varepsilon(T_{h,i} - T_{c,i}) = 17^\circ\text{C} + 0.571(127 - 17)^\circ\text{C} = 79.8^\circ\text{C} \quad <$$

The rate of heat transfer to the air is

$$q = \dot{m} c_p (T_{c,o} - T_{c,i}) = 0.03 \text{ kg/s} \times 1008 \text{ J/kg} \cdot \text{K} \times 62.8^\circ\text{C} = 1900 \text{ W}$$

and the rate of condensation is

$$\dot{m}_{\text{cond}} = \frac{q}{h_{fg}} = \frac{1900 \text{ W}}{2.183 \times 10^6 \text{ J/kg}} = 8.70 \times 10^{-4} \text{ kg/s} \quad <$$

**COMMENTS:** (1) With  $\bar{T}_c = 321.4 \text{ K}$ , the initial estimate of  $325 \text{ K}$  is reasonable and iteration on the property values is not necessary, (2) The major contribution to the total thermal resistance is due to air-side convection, (3) The foregoing results are independent of air pressure.

### PROBLEM 11.31

**KNOWN:** Tube inner and outer diameters and longitudinal and transverse pitches for a cross-flow heat exchanger. Number of tubes in transverse plane. Water and gas flow rates and inlet temperatures. Water outlet temperature.

**FIND:** (a) Gas outlet temperature and number of longitudinal tube rows, (b) Effect of gas flowrate and inlet temperature on fluid outlet temperatures.

**SCHEMATIC:**

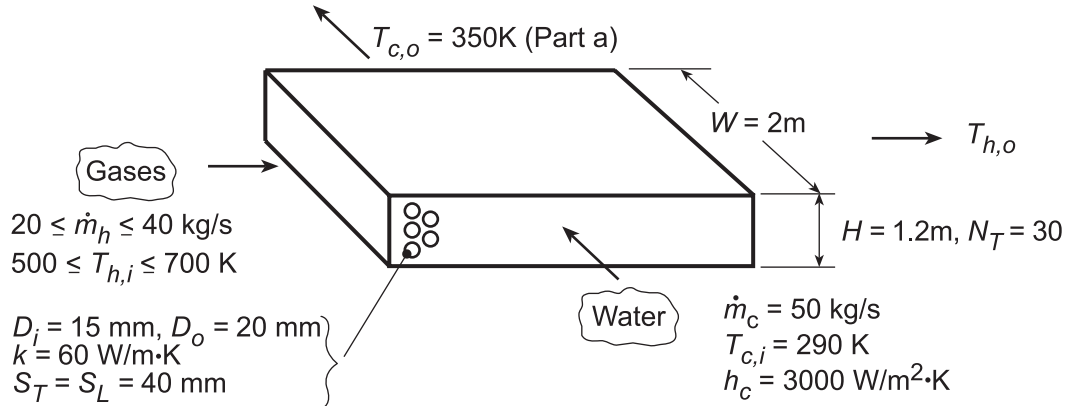

**ASSUMPTIONS:** (1) Negligible heat loss to surroundings, (2) Constant properties, (3) Negligible fouling.

**PROPERTIES:** Table A.6, Water ( $\bar{T}_c = 320$  K):  $c_p = 4180$  J/kg·K,  $\mu = 577 \times 10^{-6}$  N·s/m<sup>2</sup>,  $k_f = 0.640$  W/m·K,  $Pr = 3.77$ ; Table A.4, Air ( $\bar{T}_h \approx 550$  K):  $c_p = 1040$  J/kg·K,  $\mu = 288.4 \times 10^{-7}$  N·s/m<sup>2</sup>,  $k = 0.0439$  W/m·K,  $Pr = 0.683$ ,  $\rho = 0.633$  kg/m<sup>3</sup>.

**ANALYSIS:** (a) The required heat transfer rate is

$$q = \dot{m}_c c_{p,c} (T_{c,o} - T_{c,i}) = 50 \text{ kg/s} (4180 \text{ J/kg} \cdot \text{K}) 60 \text{ K} = 1.254 \times 10^7 \text{ W}.$$

Hence, with  $T_{h,o} = T_{h,i} - q/\dot{m}_h c_{p,h}$ ,

$$T_{h,o} = 700 \text{ K} - 1.254 \times 10^7 \text{ W} / (40 \text{ kg/s} \times 1040 \text{ J/kg} \cdot \text{K}) = 398.6 \text{ K} \quad <$$

Use the  $\epsilon$ -NTU method to compute the hot side HX surface area,  $A_H$ . To calculate  $U_h$ , we must find  $h_h$ .

For the tube bank,  $S_D = 44.7 \text{ mm} > (S_T + D)/2 = 30 \text{ mm}$ . Hence, with  $\rho V_{\max} = [S_T / (S_T - D_o)] \rho V = [S_T / (S_T - D_o)] (\dot{m}_h / WH)$ ,

$$\rho V_{\max} = (40/20) \left[ 40 \text{ kg/s} / (2 \times 1.2) \text{ m}^2 \right] = 33.3 \text{ kg/s} \cdot \text{m}^2$$

$$Re_{D,\max} = (\rho V_{\max} D_o) / \mu = \left[ 33.3 \text{ kg/s} \cdot \text{m}^2 (0.02 \text{ m}) \right] / 288.4 \times 10^{-7} \text{ N} \cdot \text{s/m}^2 = 23,116.$$

From the Zukauskas correlation, with  $(Pr/Pr_s) \approx 1$ , and Table 7.5,

$$\overline{Nu}_D = 0.35 Re_D^{0.6} Pr^{0.36} = 0.35 (23,116)^{0.6} (0.683)^{0.36} = 127$$

where it is assumed that  $N_L > 20$ . Hence,

$$h_h = \overline{Nu}_D (k/D_o) = 127 (0.0439 \text{ W/m} \cdot \text{K} / 0.02 \text{ m}) = 279 \text{ W/m}^2 \cdot \text{K}.$$

From Eq. 11.1,

Continued...

**PROBLEM 11.31 (Cont.)**

$$\frac{1}{U_h} = \frac{1}{h_c} \frac{D_o}{D_i} + \frac{D_o \ln(D_o/D_i)}{2k} + \frac{1}{h_h} = \frac{1}{3000 \text{ W/m}^2 \cdot \text{K}} \frac{20}{15} + \frac{0.02 \text{ m} \ln(20/15)}{60 \text{ W/m} \cdot \text{K}} + \frac{1}{279 \text{ W/m}^2 \cdot \text{K}}$$

$$\frac{1}{U_h} = \left( 4.44 \times 10^{-4} + 9.59 \times 10^{-5} + 3.58 \times 10^{-3} \right) \text{ m}^2 \cdot \text{K/W} = 4.12 \times 10^{-3} \text{ m}^2 \cdot \text{K/W}$$

$$U_h = 243 \text{ W/m}^2 \cdot \text{K}.$$

With  $C_h = C_{\min} = 4.160 \times 10^4 \text{ W/K}$  and  $C_c = C_{\max} = 2.09 \times 10^5 \text{ W/K}$ ,  $C_{\min}/C_{\max} = 0.199$  and  $q_{\max} = C_{\min}(T_{h,i} - T_{c,i}) = 4.16 \times 10^4 \text{ W/K}(410 \text{ K}) = 1.71 \times 10^7 \text{ W}$ . Hence,  $\epsilon = (q/q_{\max}) = (1.254 \times 10^7 \text{ W}/1.71 \times 10^7 \text{ W}) = 0.735$ . With  $C_{\min}$  mixed and  $C_{\max}$  unmixed, Eq. 11.34b gives  $\text{NTU} = 1.54$  and

$$A_h = \text{NTU}(C_{\min}/U_h) = 1.54 \left( 4.160 \times 10^4 \text{ W/K} / 243 \text{ W/m}^2 \cdot \text{K} \right) = 264 \text{ m}^2.$$

$$\text{Hence, } N_L = \frac{A_h}{(\pi D_o W) N_T} = \frac{264 \text{ m}^2}{\pi (0.02) 2(30) \text{ m}^2} = 70$$

(b) Using the IHT *Correlations, Heat Exchangers* and *Properties* Toolpads to perform the parametric calculations, we obtain the following results for  $N_L = 90$ .

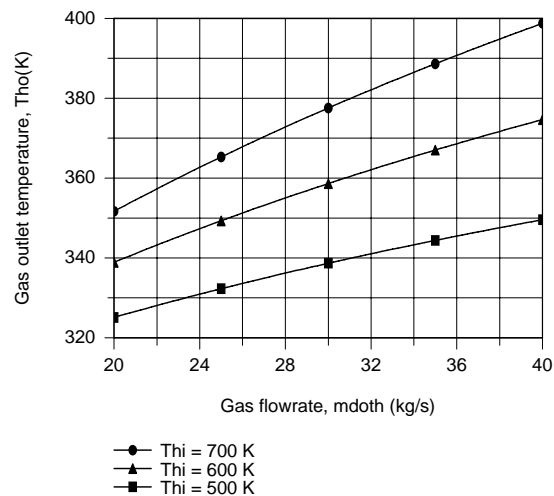
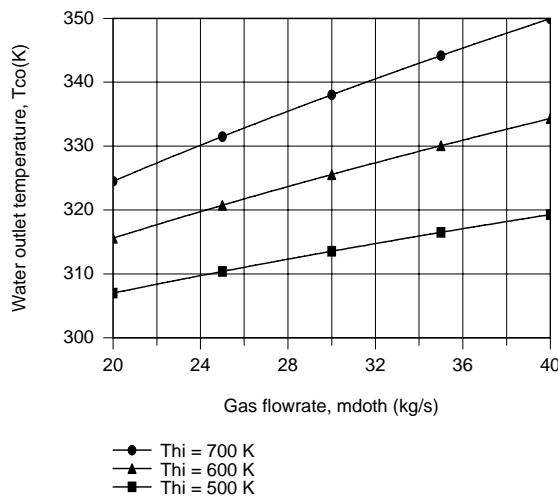

Since  $h_h$ , and hence  $U_h$ , increases with  $\dot{m}_h$ ,  $q$ , and hence,  $T_{c,o}$ , increases with increasing  $\dot{m}_h$ , as well as with increasing  $T_{h,i}$ . Although  $q$  increases with  $\dot{m}_h$ , the proportionality is not linear ( $q \propto \dot{m}_h^a$ , where  $a < 1$ ) and  $(T_{h,i} - T_{h,o})$  must decrease with increasing  $\dot{m}_h$ , in which case  $T_{h,o}$  must increase. From the above results, it is clear that operation is restricted to  $\dot{m}_h \geq 40 \text{ kg/s}$  and  $T_{h,i} \geq 700 \text{ K}$ , if corrosion of the heat exchanger surfaces is to be avoided.

**COMMENTS:** To check the presumed value of  $h_c = 3000 \text{ W/m}^2 \cdot \text{K}$ , compute

$$\text{Re}_D = \frac{4(\dot{m}_c/N)}{\pi D_i \mu} = \frac{4(50 \text{ kg/s})/70 \times 30}{\pi (0.015 \text{ m}) 577 \times 10^{-6} \text{ N} \cdot \text{s/m}^2} = 3500.$$

$$\text{Hence, } \text{Nu}_D = 0.023 \text{Re}_D^{4/5} \text{Pr}^{0.4} = 0.023(3500)^{4/5} (3.77)^{0.4} = 26.8$$

$$h_c = (k/D) \text{Nu}_D = (0.640 \text{ W/m} \cdot \text{K} / 0.015 \text{ m}) 26.8 = 1142 \text{ W/m}^2 \cdot \text{K}.$$

Hence, the cold side convection coefficient has been overestimated and the calculations should be repeated using a value of  $h_c$  calculated from the Gnielinski correlation, which applies in this Reynolds number range.

### PROBLEM 11.32

**KNOWN:** Single pass, cross-flow heat exchanger with hot exhaust gases (mixed) to heat water (unmixed)

**FIND:** Required surface area.

**SCHEMATIC:**



**ASSUMPTIONS:** (1) Negligible heat loss to surroundings, (2) Exhaust gas properties assumed to be those of air.

**PROPERTIES:** Table A-6, Water ( $\bar{T}_c = (80 + 30)^\circ\text{C}/2 = 328\text{ K}$ ):  $c_p = 4184\text{ J/kg}\cdot\text{K}$ ; Table A-4, Air (1 atm,  $\bar{T}_h = (100 + 225)^\circ\text{C}/2 = 436\text{ K}$ ):  $c_p = 1019\text{ J/kg}\cdot\text{K}$ .

**ANALYSIS:** Using the  $\epsilon$ -NTU method,

$$C_c = \dot{m}_c c_c = 3\text{ kg/s} \times 4184\text{ J/kg}\cdot\text{K} = 12,552\text{ W/K}$$

$$q = C_c (T_{c,o} - T_{c,i}) = 12,552\text{ W/K} (80 - 30)^\circ\text{C} = 627,600\text{ W}$$

From an energy balance on the hot fluid,

$$C_h = q / (T_{h,i} - T_{h,o}) = 627,600\text{ W} / (225 - 100)^\circ\text{C} = 5,021\text{ W/K}$$

Thus,  $C_r = C_{\min} / C_{\max} = 0.40$  and  $\epsilon = q / C_{\min} (T_{h,i} - T_{c,i}) = 0.641$ . With  $C_{\min}$  mixed and  $C_{\max}$  unmixed, Eq. 11.34b yields

$$\text{NTU} = -\frac{1}{C_r} \ln [C_r \ln(1 - \epsilon) + 1] = -\frac{1}{0.4} \ln [0.4 \ln(1 - 0.641) + 1] = 1.32$$

Thus,

$$A = \text{NTU} \times C_{\min} / U = 1.32 \times 5021\text{ W/K} / 200\text{ W/m}^2\cdot\text{K} = 33.1\text{ m}^2$$

<

### PROBLEM 11.33

**KNOWN:** Concentric tube heat exchanger operating in parallel flow (PF) conditions with a thin-walled separator tube of 100-mm diameter; fluid conditions as specified.

**FIND:** (a) Required length for the exchanger; (b) Convection coefficient for water flow, assumed to be fully developed; (c) Compute and plot the heat transfer rate,  $q$ , and fluid inlet temperatures,  $T_{h,o}$  and  $T_{c,o}$ , as a function of the tube length for  $60 \leq L \leq 400$  m with the PF arrangement and overall coefficient ( $U = 200 \text{ W/m}^2 \cdot \text{K}$ ), inlet temperatures ( $T_{h,i} = 225^\circ\text{C}$  and  $T_{c,i} = 30^\circ\text{C}$ ), and fluid flow rates from Problem 11.32; (d) Reduction in required length relative to the value found in part (a) if the exchanger were operated in the counterflow (CF) arrangement; and (e) Compute and plot the effectiveness and fluid outlet temperatures as a function of tube length for  $60 \leq L \leq 400$  m for the CF arrangement of part (c).

**SCHEMATIC:**

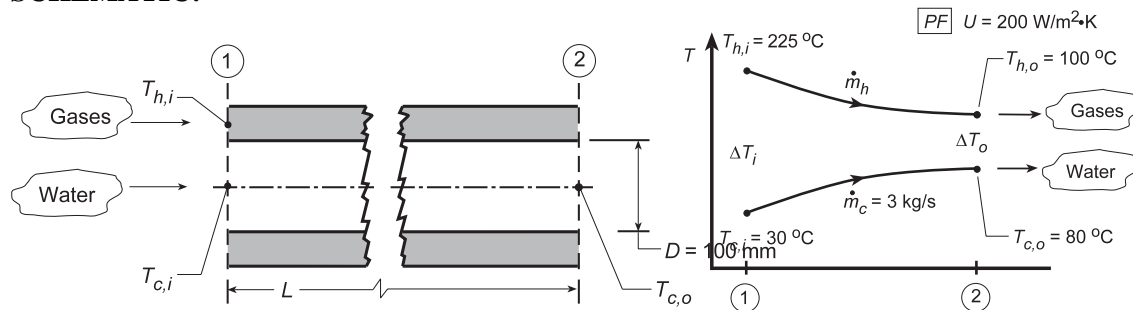

**ASSUMPTIONS:** (1) No losses to surroundings, (2) Separation tube has negligible thermal resistance, (3) Water flow is fully developed, (4) Constant properties, (5) Exhaust gas properties are those of atmospheric air.

**PROPERTIES:** Table A-4, Hot fluid, Air (1 atm,  $\bar{T} = (225 + 100)^\circ\text{C} / 2 = 436 \text{ K}$ ):  $c_p = 1019 \text{ J/kg}\cdot\text{K}$ ; Table A-6, Cold fluid, Water  $\bar{T} = (30 + 80)^\circ\text{C} / 2 \approx 328 \text{ K}$ :  $\rho = 1/v_f = 985.4 \text{ kg/m}^3$ ,  $c_p = 4183 \text{ J/kg}\cdot\text{K}$ ,  $k = 0.648 \text{ W/m}\cdot\text{K}$ ,  $\mu = 505 \times 10^{-6} \text{ N}\cdot\text{s/m}^2$ ,  $\text{Pr} = 3.58$ .

**ANALYSIS:** (a) From the rate equation, Eq. 11.14, with  $A = \pi DL$ , the length of the exchanger is

$$L = q / U \cdot \pi D \cdot \Delta T_{\ell m, \text{PF}} \quad (1)$$

The heat rate follows from an energy balance on the cold fluid, using Eq. 11.7, find

$$q = \dot{m}_c c_c (T_{c,o} - T_{c,i}) = 3 \text{ kg/s} \times 4183 \text{ J/kg}\cdot\text{K} (80 - 30) \text{ K} = 627.5 \times 10^3 \text{ W}.$$

Using an energy balance on the hot fluid, find  $\dot{m}_h$  for later use.

$$\dot{m}_h = q / c_h (T_{h,i} - T_{h,o}) = 627.5 \times 10^3 \text{ W} / 1019 \text{ J/kg}\cdot\text{K} (225 - 100) \text{ K} = 4.93 \text{ kg/s} \quad (2)$$

For parallel flow, Eqs. 11.15 and 11.16,

$$\Delta T_{\ell m, \text{PF}} = \frac{\Delta T_1 - \Delta T_2}{\ln \Delta T_1 / \Delta T_2} = \frac{(225 - 30)^\circ\text{C} - (100 - 80)^\circ\text{C}}{\ln(225 - 30) / (100 - 80)} = 76.8^\circ\text{C}.$$

Substituting numerical values into Eq. (1), find

$$L = 627.5 \times 10^3 \text{ W} / 200 \text{ W/m}^2 \cdot \text{K} (\pi \times 0.1 \text{ m}) 76.8 \text{ K} = 130 \text{ m}.$$

<

Continued...



### PROBLEM 11.33 (Cont.)

(b) Considering the water flow within the separator tube, from Eq. 8.6,

$$Re_D = 4\dot{m}/\pi D\mu = 4 \times 3 \text{ kg/s} / \left( \pi \times 0.1 \text{ m} \times 505 \times 10^{-6} \text{ N/s} \cdot \text{m}^2 \right) = 75,638.$$

Since  $Re_D > 2300$ , the flow is turbulent and since flow is assumed to be fully developed, use the Dittus-Boelter correlation with  $n = 0.4$  for heating,

$$Nu_D = 0.023 Re_D^{0.8} Pr^{0.4} = 0.023 (75,638)^{0.8} (3.58)^{0.4} = 306.4$$

$$h = Nu_D \frac{k}{D} = 306.4 \times 0.648 \text{ W/m} \cdot \text{K} / (0.1 \text{ m}) = 1985 \text{ W/m}^2 \cdot \text{K}.$$

(c) Using the *IHT Heat Exchanger Tool, Concentric Tube, Parallel Flow, Effectiveness relation*, and the *Properties Tool for Water and Air*, a model was developed for the PF arrangement. With  $U = 200 \text{ W/m}^2 \cdot \text{K}$  and prescribed inlet temperatures,  $T_{h,i} = 225^\circ\text{C}$  and  $T_{c,i} = 30^\circ\text{C}$ , the outlet temperatures,  $T_{h,o}$  and  $T_{c,o}$  and heat rate,  $q$ , were computed as a function of tube length  $L$ .

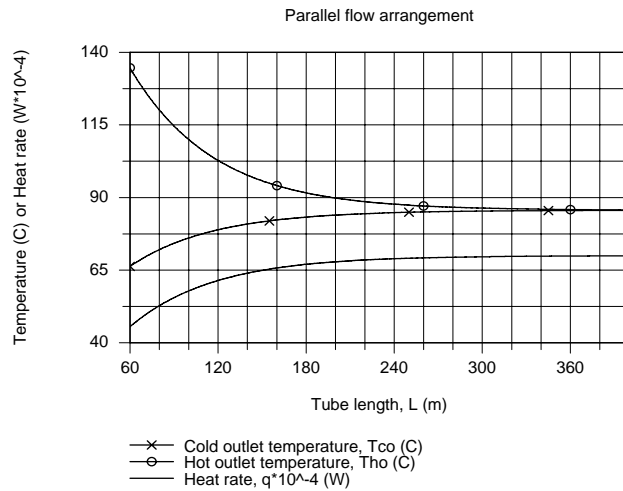

As the tube length increases, the outlet temperatures approach one another and eventually reach  $T_{h,o} = T_{c,o} = 85.6^\circ\text{C}$ .

(d) If the exchanger as for part (a) is operated in counterflow (rather than parallel flow), the log mean temperature difference is

$$\Delta T_{\ell m, CF} = \frac{\Delta T_1 - \Delta T_2}{\ln \Delta T_1 / \Delta T_2}$$

$$\Delta T_{\ell m, CF} = \frac{(225 - 80) - (100 - 30)}{\ln(225 - 80) / (100 - 30)} = 103.0^\circ\text{C}.$$

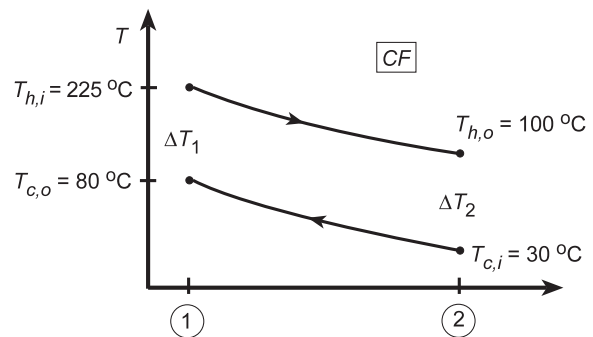

Using Eq. (1), the required length is

$$L = 627.5 \times 10^3 \text{ W} / 200 \text{ W/m}^2 \cdot \text{K} \times \pi \times 0.1 \text{ m} \times 103.0 \text{ K} = 97 \text{ m}.$$

The reduction in required length of CF relative to PF operation is

Continued...

### PROBLEM 11.33 (Cont.)

$$\Delta L = (L_{PF} - L_{CF}) / L_{PF} = (103 - 97) / 103 = 5.8\%$$

<

(e) Using the *IHT Heat Exchanger Tool, Concentric Tube, Counterflow, Effectiveness relation*, and the *Properties Tool for Water and Air*, a model was developed for the CF arrangement. For the same conditions as part (c), but CF rather than PF, the effectiveness and fluid outlet temperatures were computed as a function of tube length  $L$ .

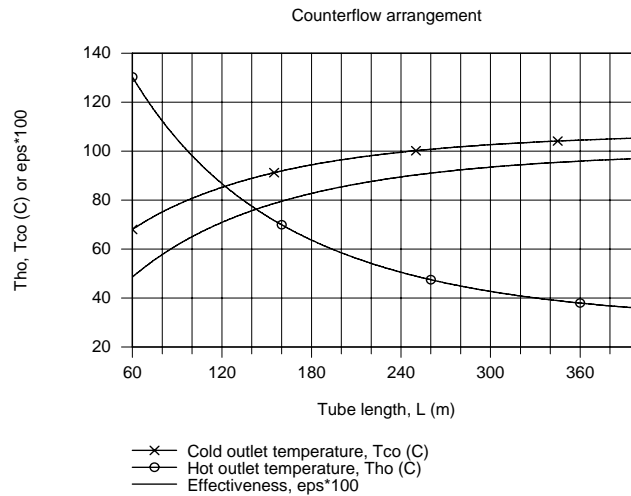

Note that as the length increases, the effectiveness tends toward unity, and the hot fluid outlet temperature tends toward  $T_{c,i} = 30^\circ\text{C}$ . Remember the heat rate for an infinitely long CF heat exchanger is  $q_{\max}$  and the minimum fluid (hot in our case) experiences the temperature change,  $T_{h,i} - T_{c,i}$ .

**COMMENTS:** (1) As anticipated, the required length for CF operations was less than for PF operation.

(2) Note that  $U$  is substantially less than  $h_i$  implying that the gas-side coefficient must be the controlling thermal resistance.

### PROBLEM 11.34

**KNOWN:** Heat exchanger in car operating between warm radiator fluid and cooler outside air. Effectiveness of heater is  $\varepsilon \sim \dot{m}_{\text{air}}^{-0.2}$  since water flow rate is large compared to that of the air. For low-speed fan condition, heater warms outdoor air from  $0^\circ\text{C}$  to  $30^\circ\text{C}$ .

**FIND:** (a) Increase in heat added to car for high-speed fan condition causing  $\dot{m}_{\text{air}}$  to be doubled while inlet temperatures remain the same, and (b) Air outlet temperature for medium-speed fan condition where air flow rate increases 50% and heat transfer increases 20%.

**SCHEMATIC:**

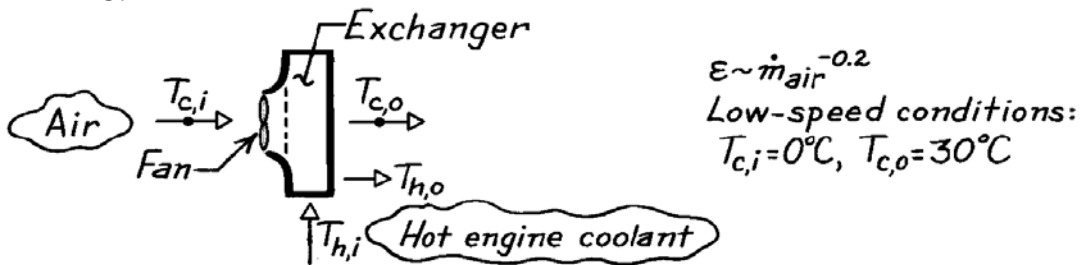

**ASSUMPTIONS:** (1) Negligible heat losses from heat exchanger to surroundings, (2)  $T_{h,i}$  and  $T_{c,i}$  remain fixed for all fan-speed conditions, (3) Water flow rate is much larger than that of air.

**ANALYSIS:** (a) Assuming the flow rate of the water is much larger than that of air,

$$C_{\min} = C_c = \dot{m}_{\text{air}} c_{p,c}$$

Hence, the heat rate can be written as

$$q = \varepsilon q_{\max} = \varepsilon C_{\min} (T_{h,i} - T_{c,i}) = \varepsilon \cdot \dot{m}_{\text{air}} c_{p,\text{air}} (T_{h,i} - T_{c,i})$$

Taking the ratio of the heat rates for the high and low speed fan conditions, find

$$\frac{q_{\text{hi}}}{q_{\text{lo}}} = \frac{(\varepsilon \dot{m}_{\text{air}})_{\text{hi}}}{(\varepsilon \dot{m}_{\text{air}})_{\text{lo}}} = \frac{(\dot{m}_{\text{air}}^{0.8})_{\text{hi}}}{(\dot{m}_{\text{air}}^{0.8})_{\text{lo}}} = 2^{0.8} = 1.74 \quad <$$

where we have used  $\varepsilon \sim \dot{m}_{\text{air}}^{-0.2}$  and recognized that for the high speed fan condition, the air flow rate is doubled. Hence the heat rate is increased by 74%.

(b) Considering the medium and low speed conditions, it was observed that,

$$\frac{q_{\text{med}}}{q_{\text{lo}}} = 1.2 \quad \frac{(\dot{m}_{\text{air}})_{\text{med}}}{(\dot{m}_{\text{air}})_{\text{lo}}} = 1.5$$

To find the outlet air temperature for the medium speed condition,

$$\frac{q_{\text{med}}}{q_{\text{lo}}} = \frac{[\dot{m}_{\text{air}} c_{p,c} (T_{c,o} - T_{c,i})]_{\text{med}}}{[\dot{m}_{\text{air}} c_{p,c} (T_{c,o} - T_{c,i})]_{\text{lo}}}$$

$$1.2 = \frac{1.5 (T_{c,o} - 0^\circ\text{C})}{(30 - 0^\circ\text{C})} \quad T_{c,o} = 24^\circ\text{C} \quad <$$

### PROBLEM 11.35

**KNOWN:** Counterflow heat exchanger formed by two brazed tubes with prescribed hot and cold fluid inlet temperatures and flow rates.

**FIND:** Outlet temperature of the air.

**SCHEMATIC:**

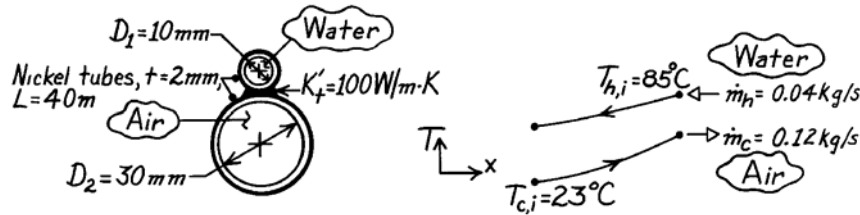

**ASSUMPTIONS:** (1) Negligible loss/gain from tubes to surroundings, (2) Flow in tubes is fully developed since  $L/D_h = 40 \text{ m}/0.030 \text{ m} = 1333$ .

**PROPERTIES:** Table A-6, Water ( $\bar{T}_h = 335 \text{ K}$ ):  $c_h = c_{p,h} = 4186 \text{ J/kg}\cdot\text{K}$ ,  $\mu = 453 \times 10^{-6} \text{ N}\cdot\text{s/m}^2$ ,  $k = 0.656 \text{ W/m}\cdot\text{K}$ ,  $Pr = 2.88$ ; Table A-4, Air (300 K):  $c_c = c_{p,c} = 1007 \text{ J/kg}\cdot\text{K}$ ,  $\mu = 184.6 \times 10^{-7} \text{ N}\cdot\text{s/m}^2$ ,  $k = 0.0263 \text{ W/m}\cdot\text{K}$ ,  $Pr = 0.707$ ; Table A-1, Nickel ( $\bar{T} = (23 + 85)^\circ\text{C}/2 = 327 \text{ K}$ ):  $k = 88 \text{ W/m}\cdot\text{K}$ .

**ANALYSIS:** Using the NTU -  $\epsilon$  method, from Eq. 11.28a,

$$\epsilon = \frac{1 - \exp[-NTU(1 - C_r)]}{1 - C_r \exp[-NTU(1 - C_r)]} \quad NTU = UA / C_{\min} \quad C_r = C_{\min} / C_{\max} \quad (1,2,3)$$

Estimate UA from a model of the tubes and flows, and determine the outlet temperature from the expression

$$\epsilon = C_c (T_{c,o} - T_{c,i}) / C_{\min} (T_{h,i} - T_{c,i}) \quad (4)$$

$$\text{Water-side:} \quad Re_D = \frac{4\dot{m}_h}{\pi D \mu} = \frac{4 \times 0.04 \text{ kg/s}}{\pi \times 0.010 \text{ m} \times 453 \times 10^{-6} \text{ N}\cdot\text{s/m}^2} = 11,243.$$

The flow is turbulent and since fully developed, use the Dittus-Boelter correlation,

$$\overline{Nu}_h = \bar{h}_h D / k = 0.023 Re_D^{0.8} Pr^{0.3} = 0.023 (11,243)^{0.8} (2.88)^{0.3} = 54.99$$

$$\bar{h}_h = 54.99 \times 0.656 \text{ W/m}\cdot\text{K} / 0.01 \text{ m} = 3,607 \text{ W/m}^2 \cdot \text{K}.$$

$$\text{Air-side:} \quad Re_D = \frac{4\dot{m}_c}{\pi D \mu} = \frac{4 \times 0.120 \text{ kg/s}}{\pi \times 0.030 \text{ m} \times 184.6 \times 10^{-7} \text{ N}\cdot\text{s/m}^2} = 275,890.$$

The flow is turbulent and since fully developed, again use the correlation

$$\overline{Nu}_c = \bar{h}_c D / k = 0.023 Re_D^{0.8} Pr^{0.4} = 0.023 (275,890)^{0.8} (0.707)^{0.4} = 450.9$$

$$\bar{h}_c = 450.9 \times 0.0263 \text{ W/m}\cdot\text{K} / 0.030 \text{ m} = 395.3 \text{ W/m}^2 \cdot \text{K}.$$

**Overall coefficient:** From Eq. 11.1, considering the temperature effectiveness of the tube walls and the thermal conductance across the brazed region,

Continued ...

**PROBLEM 11.35 (Cont.)**

$$\frac{1}{UA} = \frac{1}{(\eta_o hA)_h} + \frac{1}{K'_t L} + \frac{1}{(\eta_o hA)_c} \quad (5)$$

where  $\eta_o$  needs to be evaluated for each of the tubes. Note that each tube can be viewed as two fins of length  $\pi D/2$ . However, since the fins exchange heat on only one side, they can be combined into a single fin of length  $\pi D/2$  and thickness  $2t$ , exchanging heat on both sides.

*Water-side temperature effectiveness:*  $A_h = \pi D_h L = \pi (0.010\text{m}) 40\text{m} = 1.257\text{m}^2$

$$\eta_{o,h} = \eta_{f,h} = \tanh(mL_h) / mL_h \quad m = (\bar{h}_h P / kA)^{1/2} = (h_h / kt)^{1/2}$$

$$m = \left( 3607 \text{ W/m}^2 \cdot \text{K} / 88 \text{ W/m} \cdot \text{K} \times 0.002\text{m} \right)^{1/2} = 143.2 \text{ m}^{-1}$$

and with  $L_h = 0.5 \pi D_h$ ,  $\eta_{o,h} = \tanh(143.2 \text{ m}^{-1} \times 0.5 \pi \times 0.010\text{m}) / 143.2 \text{ m}^{-1} \times 0.5 \pi \times 0.010 \text{m} = 0.435$ .

*Air-side temperature effectiveness:*  $A_c = \pi D_c L = \pi (0.030\text{m}) 40\text{m} = 3.770\text{m}^2$

$$\eta_{o,c} = \eta_{f,c} = \tanh(mL_c) / mL_c \quad m = \left( 395.3 \text{ W/m}^2 \cdot \text{K} / 88 \text{ W/m} \cdot \text{K} \times 0.002\text{m} \right)^{1/2} = 47.39 \text{ m}^{-1}$$

and with  $L_c = 0.5 \pi D_c$ ,  $\eta_{o,c} = \tanh(47.39 \text{ m}^{-1} \times 0.5 \pi \times 0.030\text{m}) / 47.39 \text{ m}^{-1} \times 0.5 \pi \times 0.030\text{m} = 0.438$ .

Hence, the overall heat transfer coefficient using Eq. (5) is

$$\frac{1}{UA} = \frac{1}{0.435 \times 3607 \text{ W/m}^2 \cdot \text{K} \times 1.257\text{m}^2} + \frac{1}{100 \text{ W/m} \cdot \text{K} (40\text{m})} + \frac{1}{0.438 \times 395.3 \text{ W/m}^2 \cdot \text{K} \times 3.770\text{m}^2}$$

$$UA = \left[ 5.070 \times 10^{-4} + 2.50 \times 10^{-4} + 1.533 \times 10^{-3} \right]^{-1} \text{ W/K} = 437 \text{ W/K}.$$

Evaluating now the *heat exchanger effectiveness* from Eq. (1) with

$$\left. \begin{aligned} C_h = \dot{m}_h c_h = 0.040 \text{ kg/s} \times 4186 \text{ J/kg} \cdot \text{K} = 167.4 \text{ W/K} \leftarrow C_{\max} \\ C_c = \dot{m}_c c_c = 0.120 \text{ kg/s} \times 1007 \text{ J/kg} \cdot \text{K} = 120.8 \text{ W/K} \leftarrow C_{\min} \end{aligned} \right\} C_r = C_{\min} / C_{\max} = 0.722$$

$$NTU = \frac{UA}{C_{\min}} = \frac{437 \text{ W/K}}{120.8 \text{ W/K}} = 3.62 \quad \varepsilon = \frac{1 - \exp[-3.62(1 - 0.722)]}{1 - 0.722 \exp[-3.62(1 - 0.722)]} = 0.862$$

and finally from Eq. (4) with  $C_{\min} = C_c$ ,

$$0.862 = \frac{C_c (T_{c,o} - 23^\circ\text{C})}{C_c (85 - 23)^\circ\text{C}} \quad T_{c,o} = 76.4^\circ\text{C} \quad <$$

**COMMENTS:** (1) Using overall energy balances, the water outlet temperature is

$$T_{h,o} = T_{h,i} + (C_c / C_h)(T_{c,o} - T_{c,i}) = 85^\circ\text{C} - 0.722(76.4 - 23)^\circ\text{C} = 46.4^\circ\text{C}.$$

(2) To initially evaluate the properties, we assumed that  $\bar{T}_h \approx 335 \text{ K}$  and  $\bar{T}_c \approx 300 \text{ K}$ . From the calculated values of  $T_{h,o}$  and  $T_{c,o}$ , more appropriate estimates of  $\bar{T}_h$  and  $\bar{T}_c$  are  $338 \text{ K}$  and  $322 \text{ K}$ , respectively. We conclude that proper thermophysical properties were used for water but that the estimates could be improved for air.

## PROBLEM 11.36

**KNOWN:** Air and ammonia flow rates and inlet temperatures. Relationship of  $UA$  product to water flow rate. Water mass flow rates in tubes. Heat exchanger type.

**FIND:** (a) Air and ammonia outlet temperatures and heat transfer rate. (b) Air and ammonia outlet temperatures for water flow rates in the range  $0 \text{ kg/s} \leq \dot{m}_{c,A} = \dot{m}_{h,B} \leq 2 \text{ kg/s}$ .

**SCHEMATIC:**

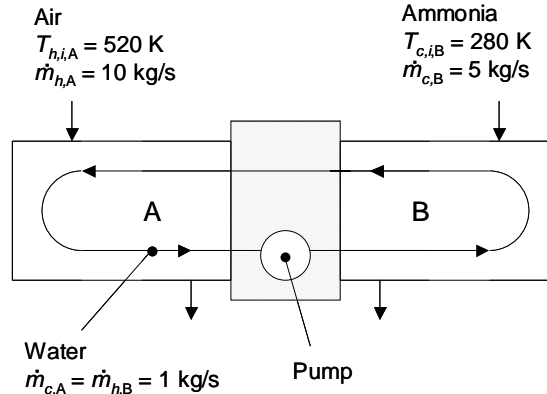

**ASSUMPTIONS:** (1) Negligible heat transfer between heat exchangers and surroundings, negligible heat transfer between two heat exchangers, (2) Constant properties, (3) Negligible energy added to the system by the pump.

**PROPERTIES:** Table A.6 (water) ( $\bar{T} = 400 \text{ K}$ ):  $c_p = 4256 \text{ J/kg}\cdot\text{K}$ . Table A.4 (air) ( $\bar{T} = 500 \text{ K}$ ):  $c_p = 1030 \text{ J/kg}\cdot\text{K}$ . Table A.4 (ammonia) ( $\bar{T} = 300 \text{ K}$ ):  $c_p = 2158 \text{ J/kg}\cdot\text{K}$ .

**ANALYSIS:** (a) For heat exchanger A,  $C_{h,A} = 10 \text{ kg/s} \times 1030 \text{ J/kg}\cdot\text{K} = 10,300 \text{ W/K}$ . For heat exchanger B,  $C_{c,B} = 5 \text{ kg/s} \times 2158 \text{ J/kg}\cdot\text{K} = 10790 \text{ W/K}$ . For the water,  $C_{c,A} = C_{h,B} = 1 \text{ kg/s} \times 4256 \text{ J/kg}\cdot\text{K} = 4256 \text{ W/K}$ . Therefore,  $C_{\min,A} = C_{\min,B} = 4256 \text{ W/K}$ . For heat exchanger A,  $UA_A = 6000 \text{ W/K} + 100 \text{ J/kg}\cdot\text{K} \times 1 \text{ kg/s} = 6100 \text{ W/K}$  while for heat exchanger B,  $UA_B = 1.2UA_A = 7320 \text{ W/K}$ . The relative heat rates are  $C_{r,A} = 4256/10,300 = 0.4132$  and  $C_{r,B} = 4256/10,790 = 0.3944$ . The number of transfer units for heat exchanger A is  $NTU_A = 6100/4256 = 1.433$ , while for heat exchanger B  $NTU_B = 7320/4256 = 1.720$ . The effectiveness may be evaluated using Eq. 11.30a resulting in  $\varepsilon_A = 0.6468$ ,  $\varepsilon_B = 0.6966$ .

For heat exchangers A and B, the following equations may be written, making special note that the water temperature is the same between the inlet and outlet of the shell-side of each heat exchanger.

$$q_A = \varepsilon_A C_{\min,A} (T_{h,i,A} - T_{c,i,A}) = 0.6468 \times 4256 \text{ W/K} \times (520 \text{ K} - T_{c,i,A}) \quad (1)$$

$$q_B = \varepsilon_B C_{\min,B} (T_{h,i,B} - T_{c,i,B}) = 0.6966 \times 4256 \text{ W/K} \times (T_{h,i,B} - 280 \text{ K}) \quad (2)$$

$$T_{h,o,A} = T_{h,i,A} - q_A / C_{\max,A} = 520 \text{ K} - q_A / 10300 \text{ W/K} \quad (3)$$

$$T_{c,o,B} = T_{c,i,B} + q_B / C_{\max,B} = 280 \text{ K} + q_B / 10790 \text{ W/K} \quad (4)$$

$$T_{h,i,B} = T_{c,o,A} \quad (5)$$

$$T_{h,o,B} = T_{c,i,A} \quad (6)$$

Equations (1) through (6) may be solved simultaneously to yield

$$q_A = q_B = 5.17 \times 10^5 \text{ W}, T_{h,o,A} = 469.8 \text{ K}, T_{c,o,B} = 327.9 \text{ K}$$

<  
Continued...

### PROBLEM 11.36 (Cont.)

In addition, we note that

$$T_{h,i,B} = T_{c,o,A} = 454.5\text{K} \qquad T_{h,o,B} = T_{c,i,A} = 332.9\text{K}$$

(b) *IHT* was used to solve the preceding equations simultaneously, and to plot the following results.

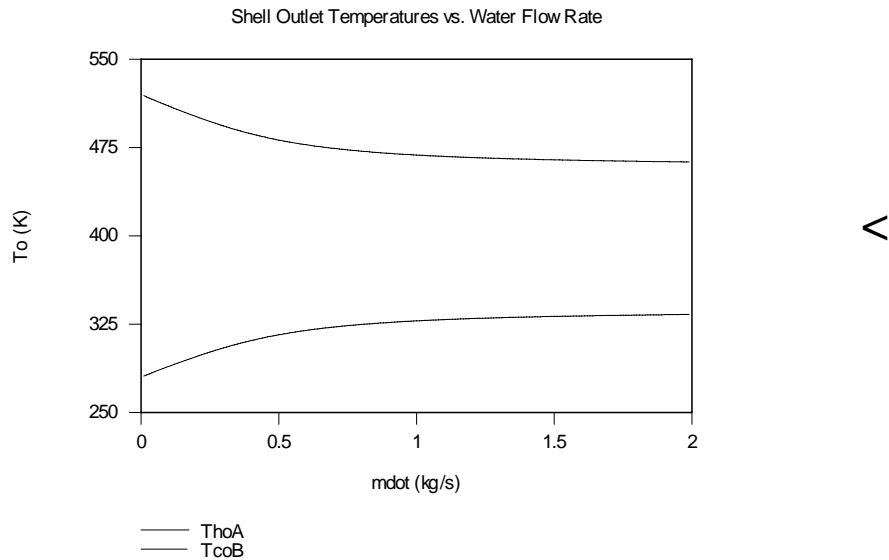

**COMMENTS:** (1) The *IHT* code used in part (b) is listed below. (2) As evident in part (b), fine-tuning is feasible, but to a limited degree for the conditions of this problem. The capability to fine-tune the device is dependent upon the *UA* values associated with each heat exchanger. Neglecting the dependence of *UA* on the water mass flow rate, the calculations were repeated and the outlet temperatures of the air in heat exchanger A are shown in the plot below.

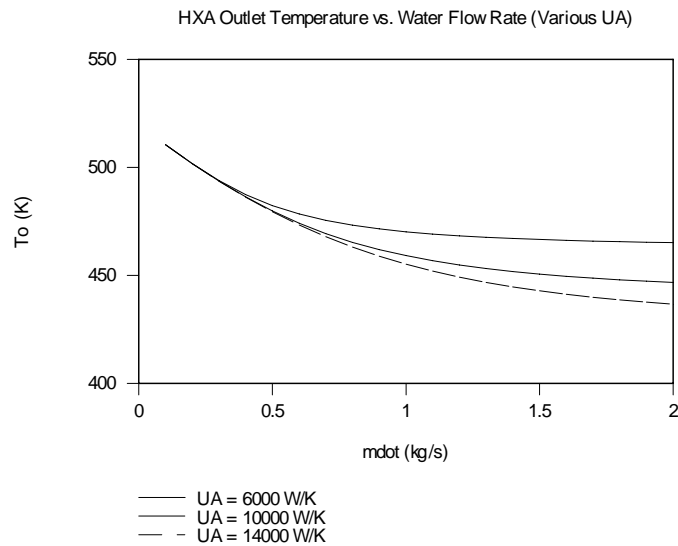

Continued...

## PROBLEM 11.36 (Cont.)

//IHT code for Cmin associated with the water flow rate

/\* For the shell-and tube heat exchanger with one shell and any multiple of two tube passes (2, 4, ...),  
\*/

$$\text{epsA} = 2 * (1 + \text{CrA} + (1 + \text{CrA}^2)^{0.5} * (1 + \exp(-\text{NTUA} * (1 + \text{CrA}^2)^{0.5})) / (1 - \exp(-\text{NTUA} * (1 + \text{CrA}^2)^{0.5})))^{(-1)} \quad //$$

// where the heat-capacity ratio is

$$\text{CrA} = \text{CminA} / \text{CmaxA}$$

// and the number of transfer units, NTUA, is

$$\text{NTUA} = \text{UAA} / \text{CminA} \quad // \text{Eq 11.24}$$

// The effectiveness is defined as

$$\text{epsA} = \text{qA} / \text{qmaxA}$$

$$\text{qmaxA} = \text{CminA} * (\text{ThiA} - \text{TciA}) \quad // \text{Eq 11.18, 11.19}$$

// See Tables 11.3 and 11.4 and Fig 11.12

/\* For the shell-and tube heat exchanger with one shell and any multiple of two tube passes (2, 4, ...),  
\*/

$$\text{epsB} = 2 * (1 + \text{CrB} + (1 + \text{CrB}^2)^{0.5} * (1 + \exp(-\text{NTUB} * (1 + \text{CrB}^2)^{0.5})) / (1 - \exp(-\text{NTUB} * (1 + \text{CrB}^2)^{0.5})))^{(-1)} \quad //$$

// where the heat-capacity ratio is

$$\text{CrB} = \text{CminB} / \text{CmaxB}$$

// and the number of transfer units, NTUB, is

$$\text{NTUB} = \text{UAB} / \text{CminB} \quad // \text{Eq 11.24}$$

// The effectiveness is defined as

$$\text{epsB} = \text{qB} / \text{qmaxB}$$

$$\text{qmaxB} = \text{CminB} * (\text{ThiB} - \text{TciB}) \quad // \text{Eq 11.18, 11.19}$$

// See Tables 11.3 and 11.4 and Fig 11.12

$$\text{mdot} = 1$$

$$\text{cpw} = 4256$$

$$\text{UAA} = 6000 + 100 * \text{mdot}$$

$$\text{UAB} = 1.2 * \text{UAA}$$

$$\text{CminA} = \text{mdot} * \text{cpw}$$

$$\text{CmaxA} = 10300$$

$$\text{CmaxB} = 10790$$

$$\text{CminB} = \text{mdot} * \text{cpw}$$

$$\text{ThiA} = 520$$

$$\text{TciB} = 280$$

$$\text{qA} = \text{CminA} * (\text{TcoA} - \text{TciA})$$

$$\text{qB} = \text{CminB} * (\text{ThiB} - \text{ThoB})$$

$$\text{ThiB} = \text{TcoA}$$

$$\text{ThoB} = \text{TciA}$$

//Equations to determine outlet temperatures on shell side

$$\text{ThoA} = \text{ThiA} - \text{qA} / \text{CmaxA}$$

$$\text{TcoB} = \text{TciB} + \text{qB} / \text{CmaxB}$$



## PROBLEM 11.37

**KNOWN:** Air and ammonia flow rates and inlet temperatures. Relationship of  $UA$  product to water flow rate. Mass flow rate of water in tubes.

**FIND:** (a) Air and ammonia outlet temperatures and heat transfer rate. (b) Air and ammonia outlet temperatures for water flow rates in the range  $5 \text{ kg/s} \leq \dot{m}_{c,A} = \dot{m}_{h,B} \leq 50 \text{ kg/s}$ .

**SCHEMATIC:**

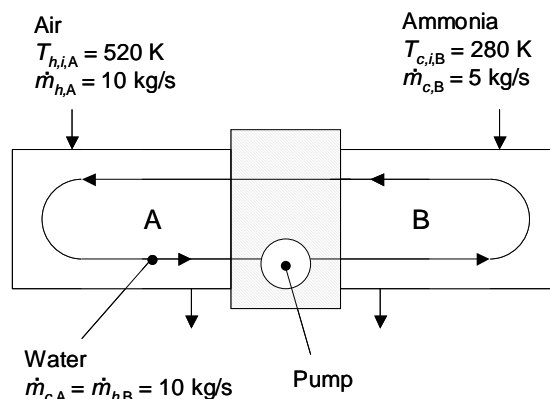

**ASSUMPTIONS:** (1) Negligible heat transfer between heat exchangers and surroundings, negligible heat transfer between two heat exchangers, (2) Constant properties.

**PROPERTIES:** Table A.6 (water) ( $\bar{T} = 400 \text{ K}$ ):  $c_p = 4256 \text{ J/kg}\cdot\text{K}$ . Table A.4 (air) ( $\bar{T} = 500 \text{ K}$ ):  $c_p = 1030 \text{ J/kg}\cdot\text{K}$ . Table A.4 (ammonia) ( $\bar{T} = 300 \text{ K}$ ):  $c_p = 2158 \text{ J/kg}\cdot\text{K}$ .

**ANALYSIS:** (a) For heat exchanger A,  $C_{h,A} = 10 \text{ kg/s} \times 1030 \text{ J/kg}\cdot\text{K} = 10,300 \text{ W/K}$ . For heat exchanger B,  $C_{c,B} = 5 \text{ kg/s} \times 2158 \text{ J/kg}\cdot\text{K} = 10,790 \text{ W/K}$ . For the water,  $C_{c,A} = C_{h,B} = 10 \text{ kg/s} \times 4256 \text{ J/kg}\cdot\text{K} = 42,560 \text{ W/K}$ . Therefore,  $C_{\min,A} = 10,300 \text{ W/K}$  and  $C_{\min,B} = 10,790 \text{ W/K}$ . For heat exchanger A,  $UA_A = 6000 \text{ W/K} + 100 \text{ J/kg}\cdot\text{K} \times 10 \text{ kg/s} = 7000 \text{ W/K}$  while for heat exchanger B,  $UA_B = 1.2UA_A = 8400 \text{ W/K}$ . The relative heat rates are  $C_{r,A} = 10,300/42,560 = 0.2420$  and  $C_{r,B} = 10,790/42,560 = 0.2535$ . The number of transfer units for heat exchanger A is  $NTU_A = 7000/10,300 = 0.6796$ , while for heat exchanger B  $NTU_B = 8400/10,790 = 0.779$ . The effectiveness may be evaluated using Eq. 11.30a resulting in  $\varepsilon_A = 0.4647$ ,  $\varepsilon_B = 0.5052$ .

For heat exchangers A and B, we may write the following, making special note that the water temperature is the same between the inlet and outlet of the shell-side of each heat exchanger.

$$q_A = \varepsilon_A C_{\min,A} (T_{h,i,A} - T_{c,i,A}) = 0.4647 \times 10300 \text{ W/K} \times (520 \text{ K} - T_{c,i,A}) \quad (1)$$

$$q_B = \varepsilon_B C_{\min,B} (T_{h,i,B} - T_{c,i,B}) = 0.5052 \times 10790 \text{ W/K} \times (T_{h,i,B} - 280 \text{ K}) \quad (2)$$

$$T_{h,o,A} = T_{h,i,A} - q_A / C_{\max,A} = 520 \text{ K} - q_A / 10300 \text{ W/K} \quad (3)$$

$$T_{c,o,B} = T_{c,i,B} + q_B / C_{\max,B} = 280 \text{ K} + q_B / 10790 \text{ W/K} \quad (4)$$

$$T_{h,i,B} = T_{c,o,A} \quad (5)$$

$$T_{h,o,B} = T_{c,i,A} \quad (6)$$

Equations (1) through (6) may be solved simultaneously to yield

$$q_A = q_B = 6.51 \times 10^5 \text{ W}, T_{h,o,A} = 456.8 \text{ K}, T_{c,o,B} = 340.3 \text{ K}$$

<  
Continued...

## PROBLEM 11.37 (Cont.)

In addition, we note that

$$T_{h,i,B} = T_{c,o,A} = 399.4\text{K} \qquad T_{h,o,B} = T_{c,i,A} = 384.1\text{K}$$

(b) *IHT* was used to solve the preceding equations simultaneously, and to plot the following results.

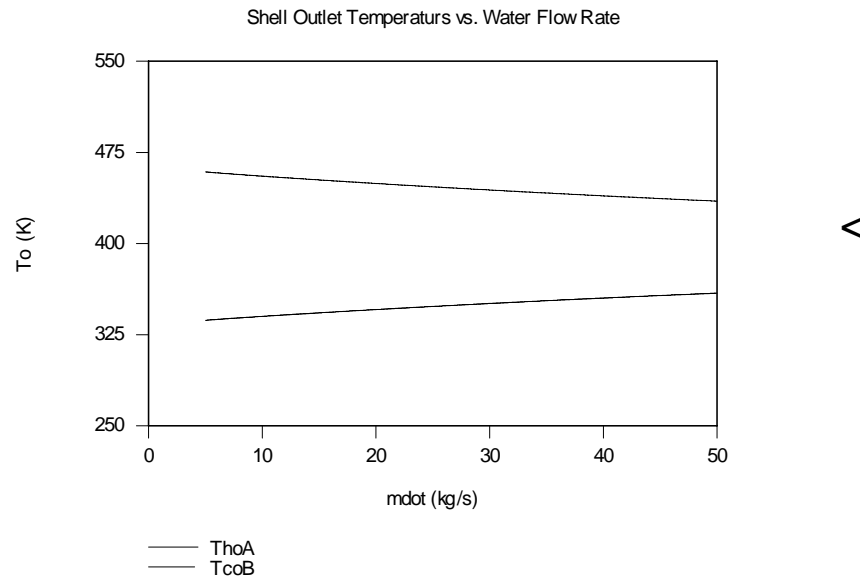

**COMMENTS:** (1) The *IHT* code used in part (b) is listed below. (2) As evident in part (b), fine-tuning is feasible.

```
//IHT code for Cmin associated with the shell-side flows
/* For the shell-and tube heat exchanger with one shell and any multiple of two tube passes (2, 4, ...),
*/
epsA = 2 * (1 + CrA + (1 + CrA^2)^0.5 * (1 + exp(-NTUA * (1 + CrA^2)^0.5)) / (1 - exp(-NTUA * (1 +
CrA^2)^0.5)))^(-1) /
// where the heat-capacity ratio is
CrA = CminA / CmaxA
// and the number of transfer units, NTUA, is
NTUA = UAA / CminA
// The effectiveness is defined as
epsA = qA / qmaxA
qmaxA = CminA * (ThiA - TciA)
// See Tables 11.3 and 11.4 and Fig 11.12

/* For the shell-and tube heat exchanger with one shell and any multiple of two tube passes (2, 4, ...),
*/
epsB = 2 * (1 + CrB + (1 + CrB^2)^0.5 * (1 + exp(-NTUB * (1 + CrB^2)^0.5)) / (1 - exp(-NTUB * (1 +
CrB^2)^0.5)))^(-1)
// where the heat-capacity ratio is
CrB = CminB / CmaxB
// and the number of transfer units, NTUB, is
NTUB = UAB / CminB
// The effectiveness is defined as
epsB = qB / qmaxB
qmaxB = CminB * (ThiB - TciB)
// See Tables 11.3 and 11.4 and Fig 11.16
```

Continued...

## PROBLEM 11.37 (Cont.)

$$\dot{m} = 10$$

$$c_{pw} = 4256$$

$$U_{AA} = 6000 + 100\dot{m}$$

$$U_{AB} = 1.2U_{AA}$$

$$C_{minA} = 10300$$

$$C_{maxA} = \dot{m}c_{pw}$$

$$C_{maxB} = \dot{m}c_{pw}$$

$$C_{minB} = 10790$$

$$T_{hiA} = 520$$

$$T_{ciB} = 280$$

$$q_A = \dot{m}c_{pw}(T_{coA} - T_{ciA})$$

$$q_B = \dot{m}c_{pw}(T_{hiB} - T_{hoB})$$

$$T_{hiB} = T_{coA}$$

$$T_{hoB} = T_{ciA}$$

//Equations to determine outlet temperatures on shell side

$$T_{hoA} = T_{hiA} - q_A/10300$$

$$T_{coB} = T_{ciB} + q_B/10790$$

## PROBLEM 11.38

**KNOWN:** Air flow rate, cold outside temperature, warm indoor temperature, dew point temperature,  $UA$  product.

**FIND:** (a) Required water flow rate.

**SCHEMATIC:**

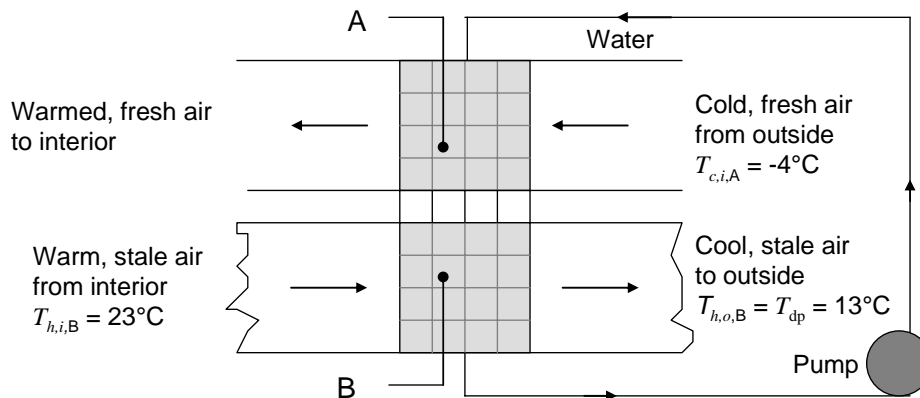

**ASSUMPTIONS:** (1) Negligible heat transfer between heat exchangers and surroundings, negligible heat transfer between two heat exchangers, (2) Constant properties, (3) Negligible energy added to the system by the pump, (4)  $C_{\max}$  is associated with the air, (5) Properties of water with anti-freeze agent are the same as properties of water.

**PROPERTIES:** Table A.6 (water) ( $\bar{T} = 9^\circ\text{C} = 283\text{ K}$ ):  $c_p = 4194\text{ J/kg}\cdot\text{K}$ . Table A.4 (air) ( $\bar{T} = 9^\circ\text{C} = 283\text{ K}$ ):  $c_p = 1007\text{ J/kg}\cdot\text{K}$ .

**ANALYSIS:** (a) Note that  $C_{\max} = C_{\text{air}} = \dot{m}c_p = 1.50\text{ kg/s} \times 1007\text{ J/kg}\cdot\text{K} = 1510\text{ W/K}$ . The heat transfer rate is  $q = q_A = q_B = C_{\max} \times (T_{h,i,B} - T_{h,o,B}) = 1510\text{ W/K} \times (23 - 13)^\circ\text{C} = 15,100\text{ W}$ . The following equations describe the behavior of the system.

$$\begin{aligned} NTU &= UA/C_{\min} = (2500\text{ W/K})/C_{\min} \\ q &= \varepsilon C_{\min} (T_{h,i,A} - T_{c,i,A}) = 15,100\text{ W} = \varepsilon C_{\min} (T_{h,i,A} - (-4^\circ\text{C})) \\ q &= \varepsilon C_{\min} (T_{h,i,B} - T_{c,i,B}) = 15,100\text{ W} = \varepsilon C_{\min} (23^\circ\text{C} - T_{c,i,B}) \\ q &= C_{\min} (T_{c,o,B} - T_{c,i,B}) = 15,100\text{ W} = C_{\min} (T_{c,o,B} - T_{c,i,B}) \\ C_r &= C_{\min}/C_{\max} \\ T_{c,o,B} &= T_{h,i,A} \\ T_{h,o,A} &= T_{c,i,B} \\ \varepsilon &= 1 - \exp\left[\left(\frac{1}{C_r}\right)(NTU)^{0.22} \left\{\exp[-C_r(NTU)^{0.78}] - 1\right\}\right] \end{aligned}$$

A trial-and-error solution yields  $\dot{m}_w = C_{\min}/c_{p,w} = (776\text{ K/W})/4194\text{ J/kg}\cdot\text{K} = 0.185\text{ kg/s}$

<

Continued...

### PROBLEM 11.38 (Cont.)

**COMMENTS:** (1) Note that the maximum allowable water flow rate to justify the assumption that  $C_{\max}$  is associated with the air flow is  $\dot{m}_{\max} = C_{\max}/c_{p,w} = 1510 \text{ W/K}/4194 \text{ J/kg}\cdot\text{K} = 0.36 \text{ kg/s}$ . The assumption is valid. (2) The maximum heat transfer rate is associated with an infinite water flow rate. For this case, the water temperature is constant at an average value of  $\bar{T} = 9^\circ\text{C} = 283 \text{ K}$  and  $C_{\min}$  is associated with the air flow and is equal to  $1510 \text{ K/W}$ . Assuming a constant value of  $UA$ , the effectiveness for an infinite  $C_{\max}$  is given by Eq. 11.35a and is  $\varepsilon = 1 - \exp(-NTU) = 1 - \exp(-2500/1510) = 0.81$ . Hence, for an infinite water flow rate,  $q = 0.81 \times 1510 \text{ W/K} \times (23 - 9.5)^\circ\text{C} = 16,500 \text{ W}$ . (3) The heat transfer rate, as well as the maximum and minimum water temperatures as a function of the water flow rate, are shown in the plots below (letting the cool stale air temperature be unknown). Note that at water mass flow rates of approximately  $0.25 \text{ kg/s}$ , the heat transfer rate asymptotically approaches that of an infinite water flow rate calculated in Comment 2.

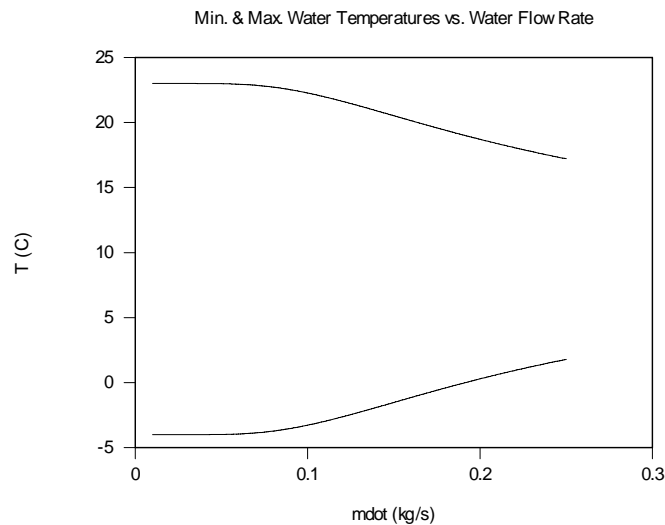
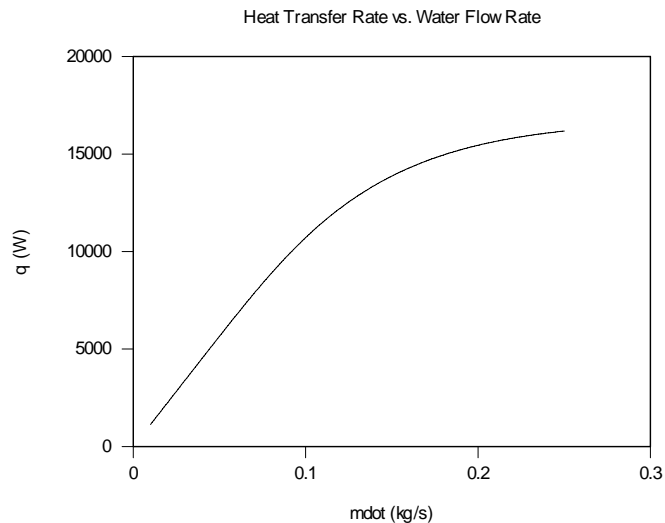

### PROBLEM 11.39

**KNOWN:** Cross-flow heat exchanger (both fluids unmixed) cools blood to induce body hypothermia using ice-water as the coolant.

**FIND:** (a) Heat transfer rate from the blood, (b) Water flow rate,  $\dot{V}_c$  (liter/min), (c) Surface area of the exchanger, and (d) Calculate and plot the blood and water outlet temperatures as a function of the water flow rate for the range,  $2 \leq \dot{V} \leq 4$  liter/min, assuming all other parameters remain unchanged.

**SCHEMATIC:**

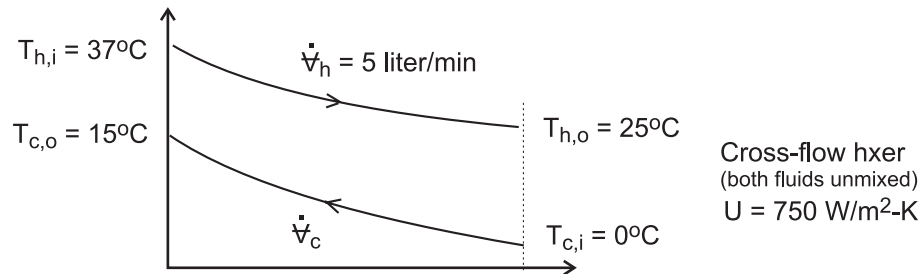

**ASSUMPTIONS:** (1) Steady-state conditions, (2) Negligible losses to the surroundings, (3) Overall heat transfer coefficient remains constant with water flow rate changes, and (4) Constant properties.

**PROPERTIES:** Table A-6, Water ( $\bar{T}_c = 280\text{K}$ ),  $\rho = 1000 \text{ kg/m}^3$ ,  $c = 4198 \text{ J/kg}\cdot\text{K}$ . Blood (given):  $\rho = 1050 \text{ kg/m}^3$ ,  $c = 3740 \text{ J/kg}\cdot\text{K}$ .

**ANALYSIS:** (a) The heat transfer rate from the blood is calculated from an energy balance on the hot fluid,

$$\dot{m}_h = \rho_h \dot{V}_h = 1050 \text{ kg/m}^3 \times (5 \text{ liter/min} \times 1 \text{ min/60 s}) \times 10^{-3} \text{ m}^3/\text{liter} = 0.0875 \text{ kg/s}$$

$$q = \dot{m}_h c_h (T_{h,i} - T_{h,o}) = 0.0875 \text{ kg/s} \times 3740 \text{ J/kg}\cdot\text{K} (37 - 25)\text{K} = 3927 \text{ W} \quad (1)$$

(b) From an energy balance on the cold fluid, find the coolant water flow rate,

$$q = \dot{m}_c c_c (T_{c,o} - T_{c,i}) \quad (2)$$

$$3927 \text{ W} = \dot{m}_c \times 4198 \text{ J/kg}\cdot\text{K} (15 - 0)\text{K} \quad \dot{m}_c = 0.0624 \text{ kg/s}$$

$$\dot{V}_c = \dot{m}_c / \rho_c = 0.0624 \text{ kg/s} / 1000 \text{ kg/m}^3 \times 10^3 \text{ liter/m}^3 \times 60 \text{ s/min} = 3.74 \text{ liter/min} \quad (3)$$

(c) The surface area can be determined using the effectiveness-NTU method. The capacity rates for the exchanger are

$$C_h = \dot{m}_h c_h = 327 \text{ W/K} \quad C_c = \dot{m}_c c_c = 262 \text{ W/K} \quad C_{\min} = C_c \quad (3, 4, 5)$$

From Eq. 11.18 and 11.19, the maximum heat rate and effectiveness are

Continued .....

**PROBLEM 11.39 (Cont.)**

$$q_{\max} = C_{\min}(T_{h,i} - T_{c,i}) = 262 \text{ W / K } (37 - 0)\text{K} = 9694 \text{ W} \quad (6)$$

$$\varepsilon = q / q_{\max} = 3927 / 9694 = 0.405 \quad (7)$$

For the cross flow exchanger, with both fluids unmixed, substitute numerical values into Eq. 11.32 to find the number of transfer units, NTU, where  $C_r = C_{\min} / C_{\max}$ .

$$\varepsilon = 1 - \exp\left[\left(1/C_r\right)NTU^{0.22}\left\{\exp\left[-C_rNTU^{0.78}\right] - 1\right\}\right] \quad (8)$$

$$NTU = 0.691$$

From Eq. 11.24, find the surface area, A.

$$NTU = UA / C_{\min}$$

$$A = 0.691 \times 262 \text{ W / K } / 750 \text{ W / m}^2 \cdot \text{K} = 0.241 \text{ m}^2 \quad <$$

(d) Using the foregoing equations in the *IHT* workspace, the blood and water outlet temperatures,  $T_{h,o}$  and  $T_{c,o}$ , respectively, are calculated and plotted as a function of the water flow rate, all other parameters remaining unchanged.

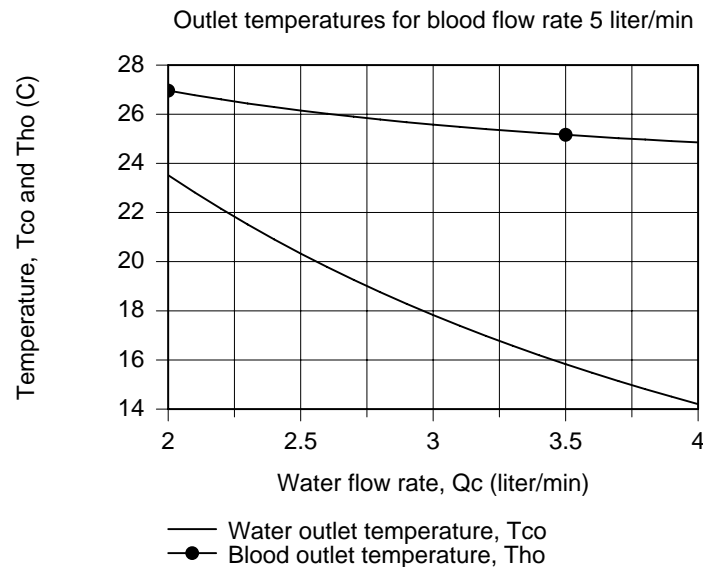

From the graph, note that with increasing water flow rate, both the blood and water outlet temperatures decrease. However, the effect of the water flow rate is greater on the water outlet temperature. This is an advantage for this application, since it is desirable to have the blood outlet temperature relatively insensitive to changes in the water flow rate. That is, if there are pressure changes on the water supply line or a slight mis-setting of the water flow rate controller, the outlet blood temperature will not change markedly.

## PROBLEM 11.40

**KNOWN:** Steam at 0.14 bar condensing in a shell and tube HXer (one shell, two tube passes consisting of 130 brass tubes of length 2 m,  $D_i = 13.4$  mm,  $D_o = 15.9$  mm). Cooling water enters at 20°C with a mean velocity 1.25 m/s. Heat transfer convection coefficient for condensation on outer tube surface is  $h_o = 13,500$  W/m<sup>2</sup>·K.

**FIND:** (a) Overall heat transfer coefficient,  $U$ , for the HXer, outlet temperature of cooling water,  $T_{c,o}$ , and condensation rate of the steam  $\dot{m}_h$ ; and (b) Compute and plot  $T_{c,o}$  and  $\dot{m}_h$  as a function of the water flow rate  $10 \leq \dot{m}_c \leq 30$  kg/s with all other conditions remaining the same, but accounting for changes in  $U$ .

**SCHEMATIC:**

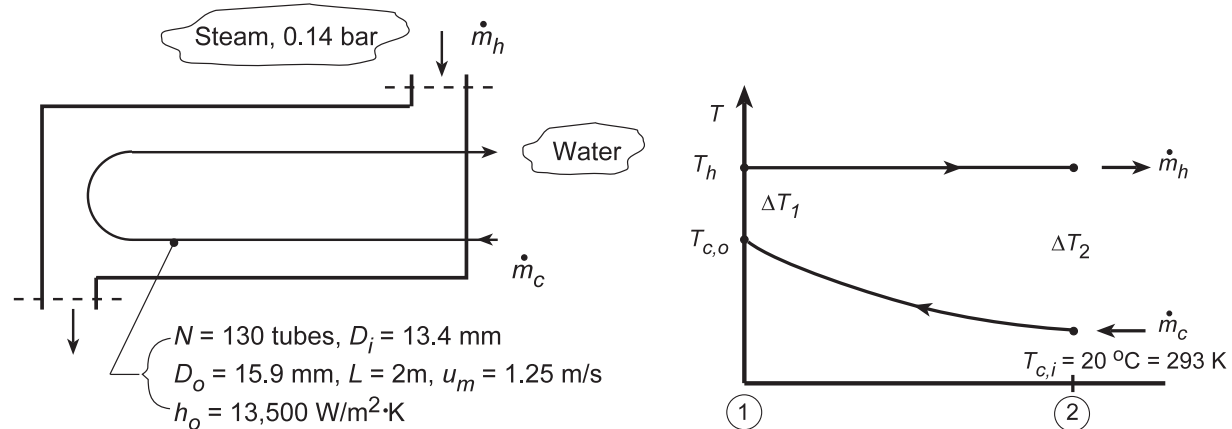

**ASSUMPTIONS:** (1) Negligible heat loss to surroundings, (2) Constant properties, (3) Fully developed water flow in tubes.

**PROPERTIES:** Table A-6, Steam (0.14 bar):  $T_{\text{sat}} = T_h = 327$  K,  $h_{fg} = 2373$  kJ/kg,  $c_p = 1898$  J/kg·K; Table A-6, Water (Assume  $T_{c,o} \approx 44^\circ\text{C}$  or  $\bar{T}_C \approx 305$  K):  $\nu_f = 1.005 \times 10^{-3}$  m<sup>3</sup>/kg,  $c_p = 4178$  J/kg·K,  $\mu_f = 769 \times 10^{-6}$  N·s/m<sup>2</sup>,  $k_f = 0.620$  W/m·K,  $\text{Pr}_f = 5.2$ ; Table A-1, Brass - 70/30 (Evaluate at  $\bar{T} = (T_h + \bar{T}_C)/2 = 316$  K):  $k = 114$  W/m·K.

**ANALYSIS:** (a) The overall heat transfer coefficient based upon the outside tube area follows from Eq. 11.5,

$$U_o = \left[ \frac{1}{h_o} + \frac{r_o}{k} \ln \frac{r_o}{r_i} + \left( \frac{r_o}{r_i} \right) \frac{1}{h_i} \right]^{-1} \quad (1)$$

The value for  $h_i$  can be estimated from an appropriate internal flow correlation. First determine the nature of the flow within the tubes. From Eq. 8.1,

$$\text{Re}_{D_i} = \rho u_m \frac{D_i}{\mu} = \frac{(1.005 \times 10^{-3} \text{ m}^3/\text{kg})^{-1} \times 1.25 \text{ m/s} \times 13.4 \times 10^{-3} \text{ m}}{769 \times 10^{-6} \text{ N}\cdot\text{s}/\text{m}^2} = 21,673.$$

The water flow is turbulent and fully developed ( $L/D_i = 2 \text{ m} / 13.4 \times 10^{-3} \text{ m} = 150 > 10$ ). The Dittus-Boelter correlation with  $n = 0.4$  is appropriate,

$$\text{Nu}_D = h_i D_i / k_f = 0.023 \text{Re}_D^{0.8} \text{Pr}_f^{0.4} = 0.023 \times (21,673)^{0.8} (5.2)^{0.4} = 130.9$$

Continued...



**PROBLEM 11.40 (Cont.)**

$$h_i = \frac{k_f}{D_i} \text{Nu}_D = \frac{0.620 \text{ W/m} \cdot \text{K}}{13.4 \times 10^{-3} \text{ m}} \times 130.9 = 6057 \text{ W/m}^2 \cdot \text{K}.$$

Substituting numerical values into Eq. (1), the overall heat transfer coefficient is

$$U_o = \left[ \frac{1}{13,500 \text{ W/m}^2 \cdot \text{K}} + \frac{(15.9 \times 10^{-3} \text{ m})/2}{114 \text{ W/m} \cdot \text{K}} \ln \frac{15.9}{13.4} + \frac{15.9}{13.4} \times \frac{1}{6057 \text{ W/m}^2 \cdot \text{K}} \right]^{-1}$$

$$U_o = \left[ 7.407 \times 10^{-5} + 1.193 \times 10^{-5} + 19.590 \times 10^{-5} \right]^{-1} \text{ W/m}^2 \cdot \text{K} = 3549 \text{ W/m}^2 \cdot \text{K}. \quad <$$

To find the outlet temperature of the water, we'll employ the  $\epsilon - \text{NTU}$  method. From an energy balance on the cold fluid,

$$T_{c,o} = T_{c,i} + q/C_c \quad (3)$$

where the heat rate can be expressed as

$$q = \epsilon q_{\max} \quad q_{\max} = C_{\min} (T_{h,i} - T_{h,o}). \quad (4,5)$$

The minimum capacity rate is that of the cold water since  $C_h \rightarrow \infty$ . Evaluating, find

$$C_{\min} = C_c = (\dot{m} c_p)_c = 22.8 \text{ kg/s} \times 4178 \text{ J/kg} \cdot \text{K} = 95,270 \text{ W/K}.$$

where

$$\dot{m}_c = (\rho A u_m) N = 995.0 \text{ kg/m}^3 \times \pi/4 (0.0134 \text{ m})^2 \times 1.25 \text{ m/s} \times 130 = 22.8 \text{ kg/s}$$

To determine  $\epsilon$ , use Fig. 11.12 (one shell and any multiple of tube passes) with  $C_r = 0$  and

$$\text{NTU} = \frac{U_o A_o}{C_{\min}} = \frac{3549 \text{ W/m}^2 \cdot \text{K} (\pi 0.0159 \text{ m} \times 2 \text{ m} \times 130 \times 2)}{95,270 \text{ W/K}} = 0.968$$

where 130 and 2 represent the number of tubes and passes, respectively, to find  $\epsilon \approx 0.62$ . Combining Eqs. (4) and (5) into Eq. (3), find

$$T_{c,o} = T_{c,i} + \epsilon C_{\min} (T_{h,i} - T_{c,i}) / C_c = 20^\circ \text{C} + 0.62 (327 - 293) \text{K} = 41.1^\circ \text{C}. \quad <$$

The condensation rate of the steam is given by

$$\dot{m}_h = q/h_{fg} \quad (6)$$

where the heat rate can be determined from Eq. (3) with  $T_{c,o}$ ,

$$\dot{m}_h = C_c (T_{c,o} - T_{c,i}) / h_{fg} = 95,270 \text{ W/K} (41.1 - 20.0) \text{K} / 2373 \times 10^3 \text{ J/kg} \cdot \text{K} = 0.85 \text{ kg/s}. \quad <$$

(b) Using the *IHT Heat Exchanger Tool, All Exchangers*,  $C_r = 0$ , and the *Properties Tool for Water*, a model was developed and the cold outlet temperature and condensation rate were computed and plotted.

Continued...

### PROBLEM 11.40 (Cont.)

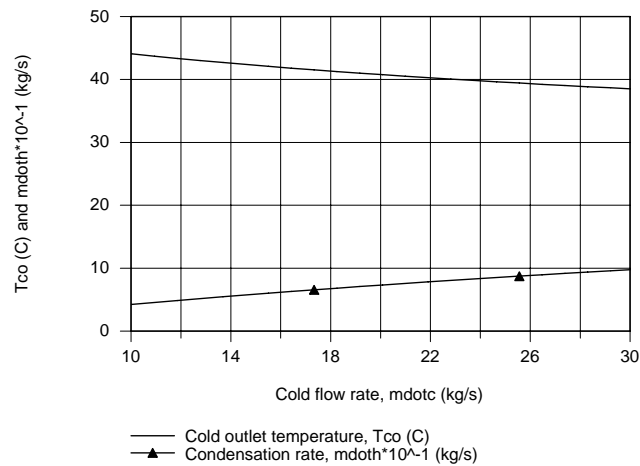

With increasing cold flow rate, the cold outlet temperature decreases as expected. The condensation rate increases with increasing cold flow rate. Note that  $T_{c,o}$  and  $\dot{m}_h$  are nearly linear with the cold flow rate.

**COMMENTS:** For part (a) analysis, note that the assumption  $T_{c,o} \approx 44^\circ\text{C}$  used for evaluation of the cold fluid properties was reasonable. Using the IHT model of part (b), we found  $T_{c,o} = 40.2^\circ\text{C}$  and  $\dot{m}_h = 0.812 \text{ kg /s}$ .

## PROBLEM 11.41

**KNOWN:** Shell-and-tube (one shell, two tube passes) heat exchanger design. Water flow rate and inlet temperature. Steam pressure and convection coefficient.

**FIND:** (a) Water outlet temperature,  $T_{c,o}$ ; (b)  $T_{c,o}$  as a function of flow rate,  $\dot{m}_c$ , for the range,  $5 \leq \dot{m}_c \leq 20$  kg/s, with all other conditions remaining the same, but accounting for changes in the overall coefficient,  $U$ ; and (c) Plot  $T_{c,o}$  on the same graph considering fouling factors of  $R_f'' = 0.0002$  and  $0.0005$  m<sup>2</sup>·K/W

**SCHEMATIC:**

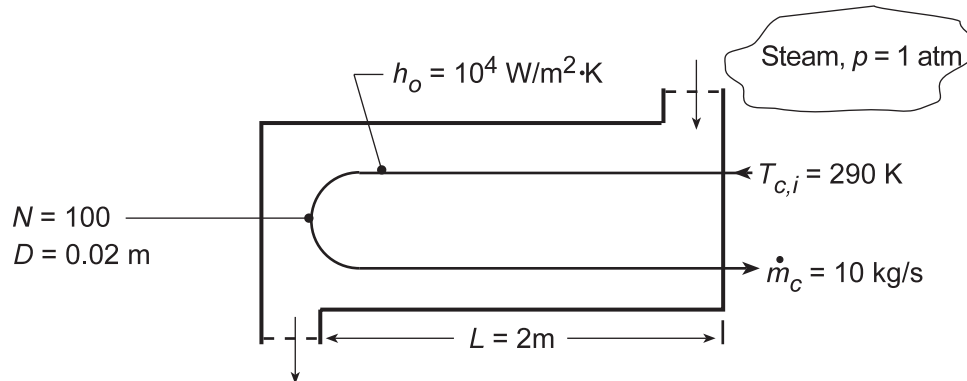

**ASSUMPTIONS:** (1) Negligible heat loss to surroundings, (2) Negligible wall conduction and fouling resistances, (3) Constant properties.

**PROPERTIES:** Table A-6, Sat. water ( $p = 1.0133$  bar):  $T_{\text{sat}} = T = 373.1$  K; ( $\bar{T}_C \approx 320$  K):  $c_p = 4180$  J/kg·K,  $\mu = 577 \times 10^{-6}$  N·s/m<sup>2</sup>,  $k = 0.640$  W/m·K,  $Pr = 3.77$ .

**ANALYSIS:** Using the NTU-effectiveness method, calculate  $U$  by finding  $h_i$ . With

$$Re_D = 4\dot{m}/\pi D\mu = [4(10 \text{ kg/s})/100] / [\pi(0.02 \text{ m})(577 \times 10^{-6} \text{ N}\cdot\text{s}/\text{m}^2)] = 11,033 \quad (1)$$

and using the Dittus-Boelter correlation,

$$Nu_D = 0.023 Re_D^{4/5} Pr^{0.4} = 0.023(11,033)^{4/5} (3.77)^{0.4} = 67.05 \quad (2)$$

$$h_i = (k/D) Nu_D = (0.640 \text{ W}/\text{m}\cdot\text{K}/0.02 \text{ m}) 67.05 = 2146 \text{ W}/\text{m}^2\cdot\text{K}.$$

From Eq. 11.5

$$1/U = 1/h_i + 1/h_o = [(1/10,000) + (1/2146)] \text{ m}^2\cdot\text{K}/\text{W} = 5.66 \times 10^{-4} \text{ m}^2\cdot\text{K}/\text{W} \quad (3)$$

$$U = 1766 \text{ W}/\text{m}^2\cdot\text{K}.$$

The heat transfer surface area, capacity rates and NTU are

$$A = N(\pi D) 2L = 100(\pi 0.02 \text{ m}) 2 \times 2 \text{ m} = 25.1 \text{ m}^2$$

$$C_{\min} = C_c = 10 \text{ kg/s}(4180 \text{ J}/\text{kg}\cdot\text{K}) = 41,800 \text{ W}/\text{K}$$

$$NTU = UA/C_{\min} = 1766 \text{ W}/\text{m}^2\cdot\text{K} \times 25.1 \text{ m}^2 / 41,800 \text{ W}/\text{K} = 1.06$$

From Eq. 11.35a

Continued...

### PROBLEM 11.41 (Cont.)

$$\varepsilon = 1 - \exp(-NTU) = 1 - \exp(-1.06) = 0.654. \quad (4)$$

With

$$q_{\max} = C_{\min} (T_{h,i} - T_{c,i}) = 41,800 \text{ W/K} (373.15 - 290) \text{ K} = 3.48 \times 10^6 \text{ W} \quad (5)$$

$$q = \varepsilon q_{\max} = 0.654 (3.48 \times 10^6 \text{ W}) = 2.27 \times 10^6 \text{ W}$$

find

$$T_{c,o} = T_{c,i} + (q/C_c) = 290 \text{ K} + (2.27 \times 10^6 \text{ W} / 41,800 \text{ W/K}) = 344.4 \text{ K}. \quad (6) <$$

(b,c) Using the *IHT Heat Exchanger Tool, All Exchangers*,  $C_r = 0$ , the *Properties Tool* for Water and the *Correlation Tool, Forced Convection, Internal Flow*, for Turbulent, fully developed conditions, a model was developed following the foregoing analysis to compute and plot the outlet temperature  $T_{c,o}$  as a function of the cold fluid flow rate,  $\dot{m}_c$ . The expression for the overall coefficient, Eq.(1), was modified to include the fouling factor,

$$1/U = 1/h_i + R_f'' + 1/h_o.$$

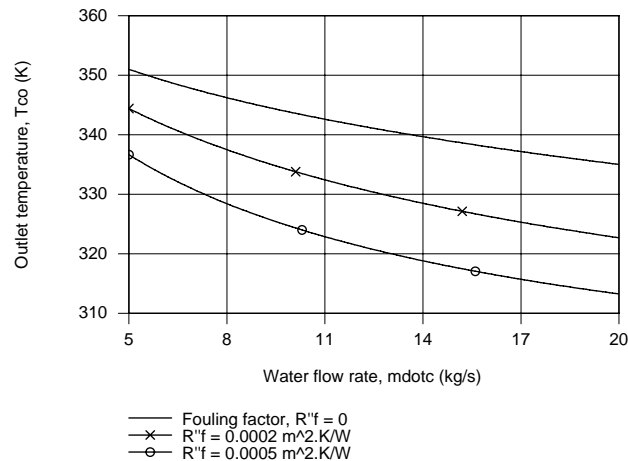

The effect of increasing the cold flow rate is to decrease the outlet temperature. The effect of the fouling resistance is to decrease the outlet temperature as well.

**COMMENTS:** (1) For the part (a) analysis,  $\bar{T}_c = 317 \text{ K}$  and the initial guess of 320 K was reasonably good.

(2) In the analysis of parts (b,c),  $Re_{D,c}$  is as low as 4880, below the turbulent range (10,000) and above the laminar range (2300). We chose to treat the flow as turbulent.

## PROBLEM 11.42

**KNOWN:** Saturated steam at 110°C condensing in a shell and tube heat exchanger (one shell pass, 2, 4, tube passes) with a UA value of 2.5 kW/K; cooling water enters at 40°C.

**FIND:** Cooling water flow rate required to maintain a heat rate of 150 kW; and (b) Calculate and plot the water flow rate required to provide heat rates over the range 130 to 160 kW, assuming that UA is independent of flow rate. Comment on the validity of the assumption.

**SCHEMATIC:**

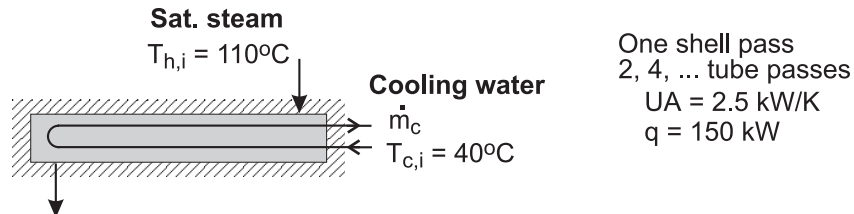

**ASSUMPTIONS:** (1) Negligible heat loss to surroundings, (2) UA independent of flow rate, and (3) Constant properties.

**PROPERTIES:** Table A-6, Water ( $T_{m,c} = (T_{c,i} + T_{c,o})/2 = 49.5^\circ\text{C} = 322.5\text{ K}$ ):  $c_{p,c} = 4181\text{ J/kg}\cdot\text{K}$ .

**ANALYSIS:** (a) For the shell-tube heat exchanger with any multiple of two-tube passes, from Eq. 11.35a with  $C_r = 0$ , using Eqs. 11.19 and 11.22,

$$\varepsilon = 1 - \exp(-NTU) \quad NTU = UA / C_{\min} \quad (1,2)$$

$$\varepsilon = q / q_{\max} \quad q_{\max} = C_c (T_{h,i} - T_{c,i}) \quad (3,4)$$

By combining the equations with  $C_{\min} = C_c = \dot{m}_c c_{p,c}$ ,

$$\frac{q}{\dot{m}_c c_{p,c} (T_{h,i} - T_{c,i})} = 1 - \exp\left(-\frac{UA}{\dot{m}_c c_{p,c}}\right) \quad (5)$$

Substituting numerical values, and solving using *IHT* find

$$\dot{m}_c = 1.89\text{ kg/s} \quad <$$

The specific heat of the cold fluid,  $c_{p,c}$ , is evaluated at the average of the mean inlet and outlet temperatures,  $T_{m,c} = (T_{c,i} + T_{c,o})/2$ , with  $T_{c,o}$  determined from the energy balance equation,

$$q = \dot{m}_c c_{p,c} (T_{c,o} - T_{c,i}). \quad (6)$$

(b) Solving the above system of equations in the *IHT* workspace, the graph below illustrates the water flow rate required to provide a range of heat rates.

Continued ...

### PROBLEM 11.42 (Cont.)

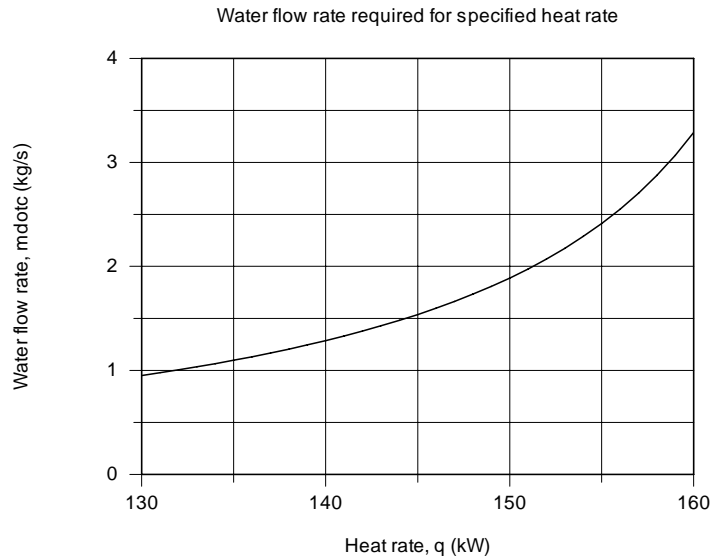

**COMMENTS:** (1) The assumption that  $UA$  is constant with flow rate is a poor one. Because the heat transfer coefficient for condensation is so high, the overall coefficient is controlled by the water-side coefficient. Presuming the flow is turbulent, from the Dittus-Boelter correlation, we'd expect  $U \propto \dot{m}_c^{0.8}$ . Over the range of the graph above,  $U$  will vary by approximately a factor of  $(3.5/1)^{0.8} = 2.7$ .

(2) If we considered  $UA$  to vary with the cold water flow rate as just described, make a sketch of  $\dot{m}_c$  vs.  $q$  and compare it to the graph above.

### PROBLEM 11.43

**KNOWN:** Temperature, convection coefficient and condensation rate of saturated steam. Tube diameter for shell-and-tube heat exchanger with one shell pass and two tube passes. Velocity and inlet and maximum allowable exit temperatures of cooling water.

**FIND:** (a) Minimum number of tubes and tube length per pass, (b) Effect of tube-side heat transfer enhancement on tube length.

**SCHEMATIC:**

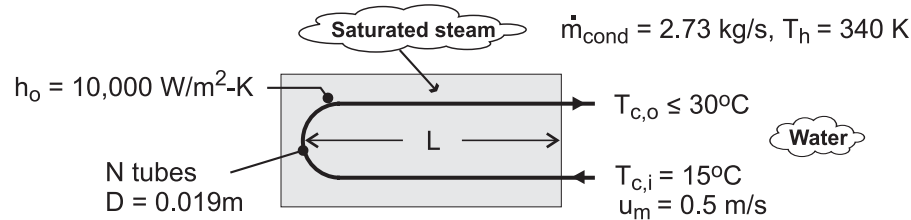

**ASSUMPTIONS:** (1) Negligible heat exchange with surroundings, (2) Negligible tube wall conduction and fouling resistance, (3) Constant properties, (4) Fully developed internal flow throughout.

**PROPERTIES:** Table A-6, Sat. water (340 K):  $h_{fg} = 2.342 \times 10^6$  J/kg; Sat. water ( $\bar{T}_c = 22.5^\circ\text{C} \approx 295$  K):  $\rho = 998$  kg/m<sup>3</sup>,  $c_p = 4181$  J/kg·K,  $\mu = 959 \times 10^{-6}$  N·s/m<sup>2</sup>,  $k = 0.606$  W/m·K, Pr = 6.62.

**ANALYSIS:** (a) The required heat rate and the maximum allowable temperature rise of the water determine the minimum allowable flow rate. That is, with

$$q = q_{\text{cond}} = \dot{m}_{\text{cond}} h_{fg} = 2.73 \text{ kg/s} \times 2.342 \times 10^6 \text{ J/kg} = 6.39 \times 10^6 \text{ W}$$

$$\dot{m}_{c,\text{min}} = \frac{q}{c_{p,c} (T_{c,o} - T_{c,i})} = \frac{6.39 \times 10^6 \text{ W}}{4181 \text{ J/kg} \cdot \text{K} (15^\circ\text{C})} = 101.9 \text{ kg/s}$$

With a specified flow rate per tube of  $\dot{m}_{c,1} = \rho u_m \pi D^2/4 = 998 \text{ kg/m}^3 \times 0.5 \text{ m/s} \times \pi (0.019 \text{ m})^2/4 = 0.141 \text{ kg/s}$ , the minimum number of tubes is

$$N_{\text{min}} = \frac{\dot{m}_{c,\text{min}}}{\dot{m}_{c,1}} = \frac{101.9 \text{ kg/s}}{0.141 \text{ kg/s}} = 720 \quad \leftarrow$$

To determine the corresponding tube length, we must first find the required heat transfer surface area. With  $Re_D = \rho u_m D / \mu = 998 \text{ kg/m}^3 (0.5 \text{ m/s}) 0.019 \text{ m} / 959 \times 10^{-6} \text{ N} \cdot \text{s/m}^2 = 9,886$ , the Dittus-Boelter equation yields

$$\bar{h}_i = (k/D) 0.023 Re_D^{4/5} Pr^{0.4} = (0.606 \text{ W/m} \cdot \text{K} / 0.019 \text{ m}) 0.023 (9886)^{4/5} (6.62)^{0.4} = 2454 \text{ W/m}^2 \cdot \text{K}$$

Continued ...

**PROBLEM 11.43 (Cont.)**

$$\text{Hence, } U = \left[ \bar{h}_i^{-1} + h_o^{-1} \right]^{-1} = 1970 \text{ W/m}^2 \cdot \text{K}$$

With  $C_r = 0$ ,  $C_{\min} = \dot{m}_c c_{p,c} = 101.9 \text{ kg/s} \times 4181 \text{ J/kg} \cdot \text{K} = 4.26 \times 10^5 \text{ W/K}$ ,  $q_{\max} = C_{\min} (T_{h,i} - T_{c,i}) = 4.26 \times 10^5 \text{ W/K} (340 - 288) \text{ K} = 2.215 \times 10^7 \text{ W}$  and  $\varepsilon = q/q_{\max} = 0.289$ , Eq. 11.35b yields  $\text{NTU} = -\ln(1 - \varepsilon) = -\ln(1 - 0.289) = 0.341$ . Hence the tube length per pass is

$$L = \frac{A}{2N\pi D} = \frac{\text{NTU} \times C_{\min}}{2N\pi DU} = \frac{0.341 \times 4.26 \times 10^5 \text{ W/K}}{2 \times 720 \times \pi (0.019\text{m}) 1970 \text{ W/m}^2 \cdot \text{K}} = 0.858\text{m} \quad <$$

(b) If the tube-side convection coefficient is doubled,  $\bar{h}_i = 4908 \text{ W/m}^2 \cdot \text{K}$  and  $U = 3292 \text{ W/m}^2 \cdot \text{K}$ . Since  $q$ ,  $C_r$ ,  $C_{\min}$ ,  $q_{\max}$  and hence  $\varepsilon$  are unchanged, the number of transfer units is still  $\text{NTU} = 0.341$ . Hence, the tube length per pass is now

$$L = \frac{\text{NTU} \times C_{\min}}{2N\pi DU} = \frac{0.341 \times 4.26 \times 10^5 \text{ W/K}}{2 \times 720 \times \pi (0.019\text{m}) 3292 \text{ W/m}^2 \cdot \text{K}} = 0.513\text{m} \quad <$$

**COMMENTS:** Heat transfer enhancement for the flow with the smallest convection coefficient significantly reduces the size of the heat exchanger.



### PROBLEM 11.44

**KNOWN:** Pressure and initial flow rate of water vapor. Water inlet and outlet temperatures. Initial and final overall heat transfer coefficients.

**FIND:** (a) Surface area for initial U and water flow rate, (b) Vapor flow rate for final U.

**SCHEMATIC:**

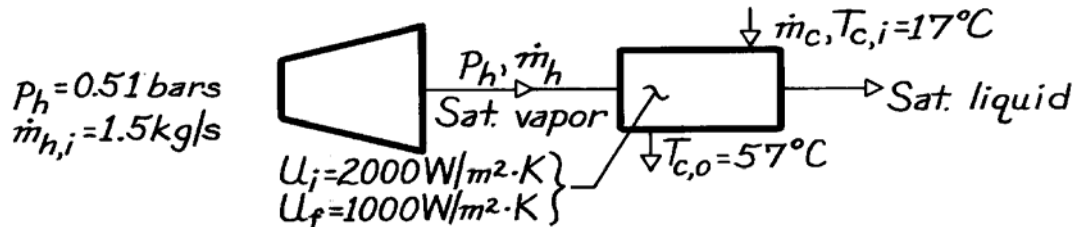

**ASSUMPTIONS:** (1) Negligible heat loss to surroundings, (2) Negligible wall conduction resistance.

**PROPERTIES:** Table A-6, Sat. water ( $\bar{T}_c = 310$  K):  $c_{p,c} = 4178$  J/kg·K; ( $p = 0.51$  bars):  $T_{\text{sat}} = 355$  K,  $h_{fg} = 2304$  kJ/kg.

**ANALYSIS:** (a) The required heat transfer rate is

$$q = \dot{m}_h h_{fg} = 1.5 \text{ kg/s} \left( 2.304 \times 10^6 \text{ J/kg} \right) = 3.46 \times 10^6 \text{ W}$$

and the corresponding heat capacity rate for the water is

$$C_c = C_{\min} = q / (T_{c,o} - T_{c,i}) = 3.46 \times 10^6 \text{ W} / 40 \text{ K} = 86,400 \text{ W/K}.$$

$$\text{Hence, } \varepsilon = q / (C_{\min} [T_{h,i} - T_{c,i}]) = 3.46 \times 10^6 \text{ W} / 86,400 \text{ W/K} (65 \text{ K}) = 0.62.$$

Since  $C_{\min}/C_{\max} = 0$ , Eq. 11.35b yields

$$NTU = -\ln(1 - \varepsilon) = -\ln(1 - 0.62) = 0.97$$

$$\text{and } A = NTU (C_{\min} / U) = 0.97 \left( 86,400 \text{ W/K} / 2000 \text{ W/m}^2 \cdot \text{K} \right) = 41.9 \text{ m}^2 \quad <$$

$$\dot{m}_c = C_c / c_{p,c} = 86,400 \text{ W/K} / 4178 \text{ J/kg} \cdot \text{K} = 20.7 \text{ kg/s.} \quad <$$

(b) Using the final overall heat transfer coefficient, find

$$NTU = UA / C_{\min} = 1000 \text{ W/m}^2 \cdot \text{K} \left( 41.9 \text{ m}^2 \right) / 86,400 \text{ W/K} = 0.485.$$

Since  $C_{\min}/C_{\max} = 0$ , Eq. 11.35a yields

$$\varepsilon = 1 - \exp(-NTU) = 1 - \exp(-0.485) = 0.384.$$

$$\text{Hence, } q = \varepsilon C_{\min} (T_{h,i} - T_{c,i}) = 0.384 (86,400 \text{ W/K}) 65 \text{ K} = 2.16 \times 10^6 \text{ W}$$

$$\dot{m}_h = q / h_{fg} = 2.16 \times 10^6 \text{ W} / 2.304 \times 10^6 \text{ J/kg} = 0.936 \text{ kg/s.} \quad <$$

**COMMENTS:** The significant reduction (38%) in  $\dot{m}_h$  represents a significant loss in turbine power. Periodic cleaning of condenser surfaces should be employed to minimize the adverse effects of fouling.

### PROBLEM 11.45

**KNOWN:** Two-fluid heat exchanger with prescribed inlet and outlet temperatures of the two fluids.

**FIND:** (a) Whether exchanger is operating in parallel or counter flow, (b) Effectiveness of the exchanger when  $C_c = C_{\min}$ .

**SCHEMATIC:**

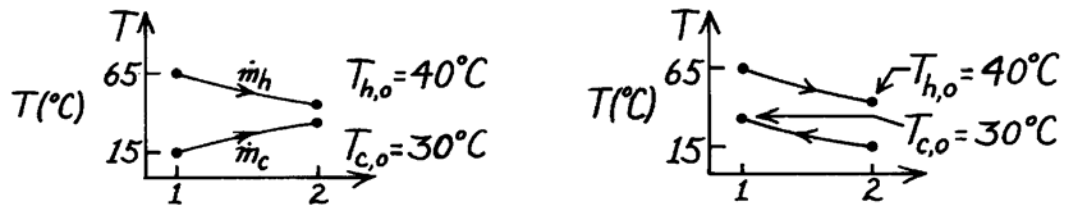

**ASSUMPTIONS:** (1) Negligible heat loss to the surroundings.

**ANALYSIS:** (a) To determine whether operation is PF or CF, consider the temperature distributions. From the distributions we note that PF or CF operation is possible.

(b) The effectiveness of the exchanger follows from Eq. 11.19,

$$\varepsilon = q / q_{\max} \quad (1)$$

where from Eq. 11.18,

$$q_{\max} = C_{\min} (T_{h,i} - T_{c,i}). \quad (2)$$

Since the hot fluid undergoes a larger temperature change than the cold fluid,  $C_{\min} = C_h$  and performing an energy balance on the cold fluid, Eq. (1) with Eq. (2) becomes

$$\varepsilon = C_h (T_{h,i} - T_{h,o}) / C_{\min} (T_{h,i} - T_{c,i}) = (T_{h,i} - T_{h,o}) / (T_{h,i} - T_{c,i})$$

$$\varepsilon = (65 - 40)^\circ\text{C} / (65 - 15)^\circ\text{C} = 0.50. \quad <$$

**COMMENTS:** If  $T_{c,o}$  were greater than  $T_{h,o}$ , parallel-flow operation would not be possible.

## PROBLEM 11.46

**KNOWN:** Length and diameters of vein and artery running from chest to base of skull. Separation distance. Inlet temperatures and mass flow rates of blood flowing in opposite directions in vein and artery. Thermal conductivity of surrounding tissue.

**FIND:** Outlet temperature of arterial blood. How much higher the arterial blood inlet temperature can be if blood flow rate is halved and exit temperature must still be below 37°C.

**SCHEMATIC:**

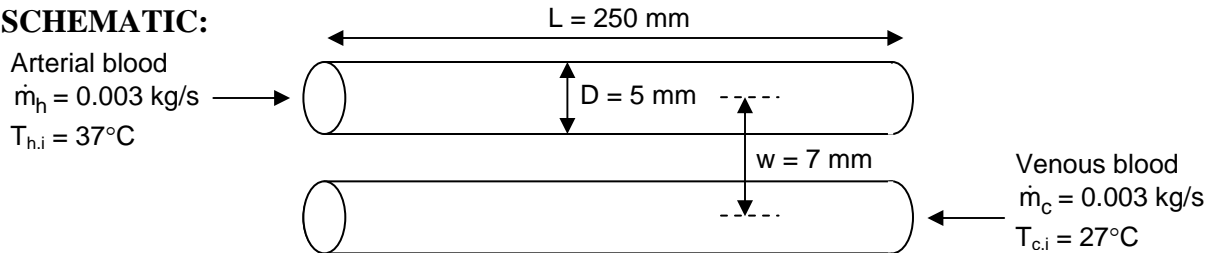

**ASSUMPTIONS:** (1) Constant properties and steady-state conditions, (2) Blood properties are those of water, (3) All heat leaving artery enters vein, (4) Vessel walls have negligible thermal resistance. (4) Properties of both flows can be evaluated at 305 K, (5) Uniform wall temperature correlation is appropriate, (5) Flows are hydrodynamically and thermally fully developed.

**PROPERTIES:** Table A.6, water: ( $T = 305 \text{ K}$ ):  $c_p = 4178 \text{ J/kg}\cdot\text{K}$ ,  $\mu = 769 \times 10^{-6} \text{ N}\cdot\text{s/m}^2$ ,  $k = 0.620 \text{ W/m}\cdot\text{K}$ . Tissue (given):  $k_t = 0.5 \text{ W/m}\cdot\text{K}$ .

**ANALYSIS:** The pair of vessels can be seen as a counterflow heat exchanger. We begin by evaluating the heat transfer coefficients, which will be the same in both vessels. From Eq. 8.6,

$$\text{Re}_D = \frac{4\dot{m}}{\pi D \mu} = \frac{4 \times 0.003 \text{ kg/s}}{\pi(0.005 \text{ m})769 \times 10^{-6} \text{ N}\cdot\text{s/m}^2} = 993$$

Hence the flow is laminar and  $\text{Nu}_D = 3.66$ . Therefore,

$$h_c = \frac{k}{D} \text{Nu}_D = \frac{0.620 \text{ W/m}\cdot\text{K}}{0.005 \text{ m}} 3.66 = 454 \text{ W/m}^2 \cdot \text{K}$$

With the assumption that all the heat that leaves the artery enters the vein, conduction between the two cylinders can be represented by the shape factor in Table 4.1, case 4. Then

$$R_{\text{cond}} = \frac{1}{S k_t} = \frac{\cosh^{-1} \left( \frac{4w^2 - 2D^2}{2D^2} \right)}{2\pi L k_t} = \frac{\cosh^{-1} \left( \frac{4(0.007 \text{ m})^2 - 2(0.005 \text{ m})^2}{2(0.005 \text{ m})^2} \right)}{2\pi \times 0.250 \text{ m} \times 0.5 \text{ W/m}\cdot\text{K}} = 2.208 \text{ K/W}$$

Then we can find  $UA$  for heat transfer between the two blood flows.

Continued...

**PROBLEM 11.46 (Cont.)**

$$\begin{aligned}
 UA^{-1} &= \frac{1}{h\pi DL} + R_{\text{cond}} + \frac{1}{h\pi DL} \\
 &= 2 \frac{1}{454 \text{ W/m}^2 \cdot \text{K} \times \pi \times 0.005 \text{ m} \times 0.25 \text{ m}} + 2.208 \text{ K/W} = 3.33 \text{ K/W}
 \end{aligned}$$

$$UA = 0.300 \text{ W/K}$$

Now using the  $\epsilon$ -NTU method, with equal heat capacity rates for the two flows,

$$NTU = \frac{UA}{\dot{m}c_p} = \frac{0.300 \text{ W/K}}{0.003 \text{ kg/s} \times 4178 \text{ J/kg} \cdot \text{K}} = 0.0240, \quad C_r = 1$$

From Eq. 11.29b, with  $C_r = 1$  and using Eq. 11.20

$$\epsilon = \frac{NTU}{NTU + 1} = \frac{0.024}{0.024 + 1} = 0.0234 = \frac{T_{h,i} - T_{h,o}}{T_{h,i} - T_{c,i}}$$

Thus

$$T_{h,o} = T_{h,i} - \epsilon(T_{h,i} - T_{c,i}) = 37^\circ\text{C} - 0.0234(37^\circ\text{C} - 27^\circ\text{C})$$

$$T_{h,o} = 36.8^\circ\text{C} \quad <$$

If the mass flow rate is halved, the flows remain laminar and the heat transfer coefficients are unchanged, as is  $UA$ . Thus,  $NTU$  doubles, i.e.  $NTU = 0.0480$ , and  $\epsilon = 0.048/1.048 = 0.0458$ .

Thus

$$\epsilon = \frac{T_{h,i} - T_{h,o}}{T_{h,i} - T_{c,i}}, \quad T_{h,i} = \frac{T_{h,o} - \epsilon T_{c,i}}{1 - \epsilon} = \frac{37^\circ\text{C} - 0.0458 \times 27^\circ\text{C}}{1 - 0.0458} = 37.5^\circ\text{C} \quad <$$

**COMMENTS:** (1) The assumed mean temperature is not accurate, but this is not worth correcting since the properties of blood are not those of water. (2) With  $x_{fd,h} = 0.05\text{Re}_D\text{Pr}_D = 1.3$  m, the flow is not fully developed thermally. The actual heat transfer coefficients would be greater and there would be a larger temperature change between inlet and outlet. (3) Heat transfer from the artery to the cooler neck surface can have a comparable or somewhat larger effect on cooling the arterial blood.

### PROBLEM 11.47

**KNOWN:** A very long, concentric tube heat exchanger having hot and cold water inlet temperatures, 85°C and 15°C, respectively; flow rate of hot water is twice that of the cold water.

**FIND:** Outlet temperatures for counterflow and parallel flow operation.

**SCHEMATIC:**

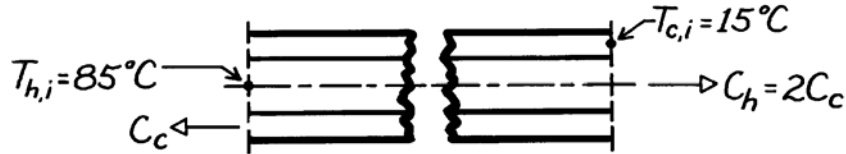

**ASSUMPTIONS:** (1) Equivalent hot and cold water specific heats, (2) No heat loss to surroundings.

**ANALYSIS:** The heat rate for a concentric tube heat exchanger with very large surface area operating in the counterflow mode is

$$q = q_{\max} = C_{\min} (T_{h,i} - T_{c,i})$$

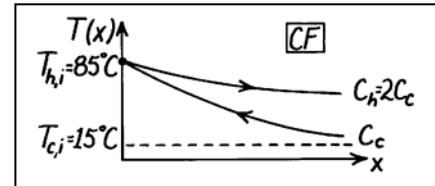

where  $C_{\min} = C_c$ . From an energy balance on the hot fluid,

$$q = C_h (T_{h,i} - T_{h,o}).$$

Combining the above relations and rearranging, find

$$T_{h,o} = -\frac{C_{\min}}{C_h} (T_{h,i} - T_{c,i}) + T_{h,i} = -\frac{C_c}{C_h} (T_{h,i} - T_{c,i}) + T_{h,i}.$$

Substituting numerical values,

$$T_{h,o} = -\frac{1}{2} (85 - 15)^\circ\text{C} + 85^\circ\text{C} = 50^\circ\text{C}.$$

For parallel flow operation, the hot and cold outlet temperatures will be equal; that is,  $T_{c,o} = T_{h,o}$ . Hence,

$$C_c (T_{c,o} - T_{c,i}) = C_h (T_{h,i} - T_{h,o}).$$

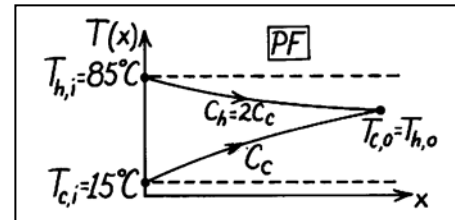

Setting  $T_{c,o} = T_{h,o}$  and rearranging,

$$T_{h,o} = \left( T_{h,i} + \frac{C_c}{C_h} T_{c,i} \right) / \left( 1 + \frac{C_c}{C_h} \right)$$

$$T_{h,o} = \left( 85 + \frac{1}{2} \times 15 \right)^\circ\text{C} / \left( 1 + \frac{1}{2} \right) = 61.7^\circ\text{C}.$$

**COMMENTS:** Note that while  $\varepsilon = 1$  for CF operation, for PF operation find  $\varepsilon = q/q_{\max} = 0.67$ .

## PROBLEM 11.48

**KNOWN:** Saturation temperature and condensation rate of refrigerant. Frontal area of condenser and dependence of overall coefficient on inlet velocity. Operational range of the air inlet temperature.

**FIND:** (a) Required heat exchanger area and air outlet temperature for prescribed air inlet velocity and temperature, (b) Variation in air velocity needed to achieve prescribed condensation rate.

**SCHEMATIC:**

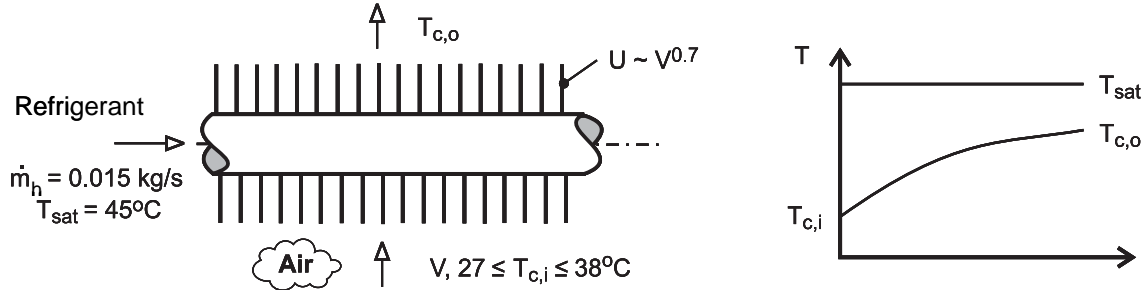

**ASSUMPTIONS:** (1) Negligible heat loss to surroundings, (2) Constant properties.

**PROPERTIES:** Given (Refrigerant):  $h_{fg} = 1.35 \times 10^5 \text{ J/kg}$ . Table A-4, air ( $T_{c,i} = 303 \text{ K}$ ):  $\rho_c = 1.17 \text{ kg/m}^3$ ,  $c_{p,c} = 1007 \text{ J/kg}\cdot\text{K}$ .

**ANALYSIS:** (a) With  $\dot{m}_c = \rho_c V A_{fr} = 1.17 \text{ kg/m}^3 \times 2 \text{ m/s} \times 0.25 \text{ m}^2 = 0.585 \text{ kg/s}$ ,

$C_{\min} = \dot{m}_c c_{p,c} = 589 \text{ W/K}$ . Hence, from Eq. 11.18, with  $T_{h,i} = T_{\text{sat}}$ ,

$$q_{\max} = C_{\min} (T_{h,i} - T_{c,i}) = 589 \text{ W/K} (45 - 30) \text{ K} = 8,836 \text{ W}$$

and with  $q = \dot{m}_h h_{fg} = 0.015 \text{ kg/s} \times 1.35 \times 10^5 \text{ J/kg} = 2025 \text{ W}$

$$\varepsilon = \frac{q}{q_{\max}} = \frac{2025}{8836} = 0.229$$

From Eq. 11.35b we then obtain (for  $C_r = 0$ ),

$$A = \frac{C_{\min}}{U} \text{NTU} = -\frac{C_{\min}}{U} \ln(1 - \varepsilon) = -\frac{589 \text{ W/K}}{50 \text{ W/m}^2 \cdot \text{K}} \ln(0.771) = 3.067 \text{ m}^2 \quad <$$

With  $q = C_{\min} (T_{c,o} - T_{c,i})$ , the outlet temperature is

$$T_{c,o} = T_{c,i} + \frac{q}{C_{\min}} = 30^\circ\text{C} + \frac{2025 \text{ W}}{589 \text{ W/K}} = 33.4^\circ\text{C} \quad <$$

(b) With  $q = 2025 \text{ W}$ ,  $A = 3.06 \text{ m}^2$  and  $U = 50 \text{ W/m}^2 \cdot \text{K} (V/2)^{0.7}$ , the foregoing equations may be solved to obtain  $V$  as a function of  $T_{c,i}$ .

Continued...

### PROBLEM 11.48 (Cont.)

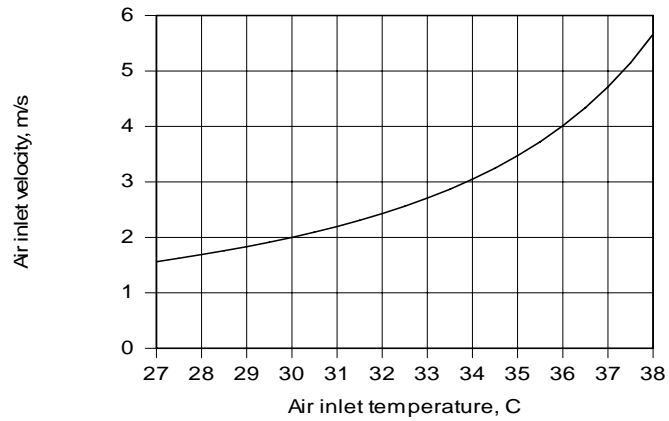

With increasing  $T_{c,i}$ , the driving potential for heat transfer,  $T_{h,i} - T_{c,i}$ , decreases and a larger value of  $U$ , and hence  $V$ , is needed to maintain the required heat rate. For  $27 \leq T_{c,i} \leq 38^\circ\text{C}$ ,  $1.56 \leq V \leq 5.66$  m/s and  $42.1 \leq U \leq 103.6 \text{ W/m}^2 \cdot \text{K}$ .

**COMMENTS:** The variation of  $V$  with  $T_{c,i}$  is nonlinear, and, in principle,  $V \rightarrow \infty$  as  $T_{c,i} \rightarrow T_{\text{sat}}$ .

## PROBLEM 11.49

**KNOWN:** Conditions of oil and water for heat exchanger, one shell with 4 tube passes.

**FIND:** Length of exchanger tubes per pass,  $L$ ; and (b) Compute and plot the effectiveness,  $\epsilon$ , fluid outlet temperatures,  $T_{h,o}$  and  $T_{c,o}$ , and water-side convection coefficient,  $h_c$ , as a function of the water flow rate for  $5000 \leq \dot{m}_c \leq 15,000$  kg/h for the tube length found in part (a) with all other conditions remaining the same.

**SCHEMATIC:**

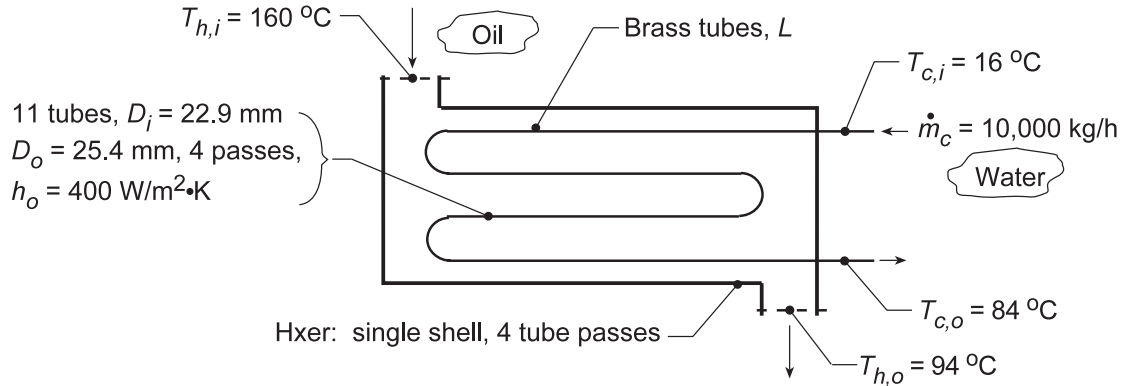

**ASSUMPTIONS:** (1) Negligible heat loss to surroundings, (2) Constant properties, (3) Fully-developed flow in tubes.

**PROPERTIES:** Table A-1, Brass (400 K):  $k = 137$  W/m·K; Table A-5, Water (323 K):  $\rho = 998.1$  kg/m<sup>3</sup>,  $k = 0.643$  W/m·K,  $c_p = 4182$  J/kg·K,  $\mu = 548 \times 10^{-6}$  N·s/m<sup>2</sup>,  $Pr = 3.56$ .

**ANALYSIS:** (a) Using the  $\epsilon$ -NTU method,

$$C_c = \dot{m}_c c_c = \frac{10,000 \text{ kg/h}}{3600 \text{ s/h}} \times 4182 \text{ J/kg} \cdot \text{K} = 11,620 \text{ W/K}$$

From an energy balance on the water,  $q = C_c(T_{c,o} - T_{c,i}) = 11,620 \text{ W/K}(84 - 16)^\circ\text{C} = 789,900 \text{ W}$

From an energy balance on the oil,  $C_h = q/(T_{h,i} - T_{h,o}) = 789,900 \text{ W}/(160 - 94)^\circ\text{C} = 11,970 \text{ W/K}$

Thus,  $C_r = C_{\min}/C_{\max} = 0.971$ ,  $q_{\max} = C_{\min}(T_{h,i} - T_{c,i}) = 11,620 \text{ W/K}(160 - 16)^\circ\text{C} = 1.673 \times 10^6 \text{ W}$ , and  $\epsilon = q/q_{\max} = 0.472$ . From Eqs. 11.30c and 11.30b,

$$E = \frac{2/\epsilon - (1 + C_r)}{(1 + C_r^2)^{1/2}} = \frac{2/0.472 - (1 + 0.971)}{(1 + 0.971^2)^{1/2}} = 1.625$$

$$NTU = -(1 + C_r^2)^{-1/2} \ln\left(\frac{E-1}{E+1}\right) = -(1 + 0.971^2)^{-1/2} \ln\left(\frac{1.625-1}{1.625+1}\right) = 1.03 \quad (1)$$

and since  $NTU = UA/C_{\min}$ ,  $A_o = NTU \times C_{\min}/U_o$  (2)

Thus we can determine  $L$  if we know  $U_o$ . From Eq. 11.5,

$$U_o = \left[ \frac{1}{h_o} + \frac{r_o}{k} \ln \frac{r_o}{r_i} + \frac{r_o}{r_i} \frac{1}{h_i} \right]^{-1}$$

where  $h_i$  must be estimated from the appropriate correlation. With  $N = 11$ , the number of tubes,

Continued...



**PROBLEM 11.49 (Cont.)**

$$Re_D = \frac{4\dot{m}/N}{\pi D \mu} = \frac{4 \times (10,000/3600) \text{ kg/s} / (11)}{\pi \times 22.9 \times 10^{-3} \text{ m} \times 548 \times 10^{-6} \text{ N}\cdot\text{s}/\text{m}^2} = 25,621.$$

For fully developed turbulent flow, the Dittus-Boelter correlation with  $n = 0.4$  yields

$$Nu_D = h_i D/k = 0.023 Re_D^{0.8} Pr^{0.4} = 0.023 (25,621)^{0.8} (3.56)^{0.4} = 128.6$$

$$h_i = Nu_D (k/D) = 128.6 \times 0.643 \text{ W/m}\cdot\text{K} / (22.9 \times 10^{-3} \text{ m}) = 3610 \text{ W/m}^2 \cdot \text{K}.$$

$$U_o = \left[ \frac{1}{400 \text{ W/m}^2 \cdot \text{K}} + \frac{25.4 \times 10^{-3} \text{ m}}{2 \times 137 \text{ W/m}\cdot\text{K}} \ln \frac{25.4}{22.9} + \frac{25.4}{22.9} \times \frac{1}{3610 \text{ W/m}^2 \cdot \text{K}} \right]^{-1} = 355 \text{ W/m}^2 \cdot \text{K}.$$

Returning now to Eq. (2), find  $A_o$ , then the length,

$$A_o = \pi D_o L \times \text{No. of Passes} \times \text{No. of Tubes} = \pi \times 25.4 \times 10^{-3} \text{ m} \times 4 \times 11 L = 3.511 L$$

$$L = NTU \times C_{\min} / 3.511 U_o = 1.03 \times 11,620 \text{ W/K} / 3.511 \text{ m} \times 355 \text{ W/m}^2 \cdot \text{K} = 9.6 \text{ m} \quad <$$

(b) Using the *IHT Heat Exchanger Tool, Shell and Tube, One-shell pass and N tube passes*, the *Correlation Tool, Forced Convection, Internal Flow for Turbulent, fully developed condition*, and the *Properties Tool for Water*, a model was developed using the effectiveness - NTU method to compute and plot  $T_{c,o}$ ,  $T_{h,o}$ ,  $\epsilon$ , and  $h_i$  as a function of  $\dot{m}_c$ .

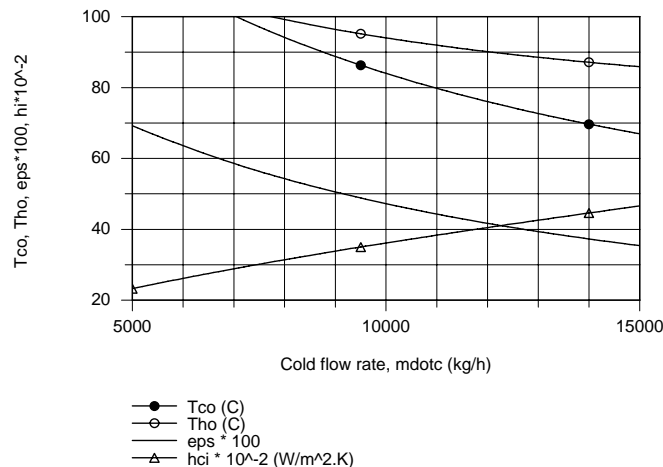

In order to avoid a boiling condition in the cold fluid, the cold flow rate should not be less than 8000 kg/h. As expected,  $T_{c,o}$  and  $T_{h,o}$  decrease and the internal convection coefficient increases nearly linearly with increasing flow rate. The effectiveness increases with increasing flow rate since the overall convection coefficient is increasing.

**COMMENT:** The thermal resistance of the brass tubes is negligible. Since  $L/D_i = 400$ , fully-developed conditions are reasonable.

## PROBLEM 11.50

**KNOWN:** Properties and flow rate of computer coolant. Diameter and number of heat exchanger tubes. Heat exchanger transfer rate and inlet temperature of computer coolant. Flow rate, specific heat, inlet temperature, and average convection coefficient of water.

**FIND:** (a) Tube flow convection coefficient,  $\bar{h}_i$ , (b) Tube length/pass required to achieve prescribed fluid outlet temperature, (c) Compute and plot the dielectric fluid outlet temperature,  $T_{f,o}$ , as a function of its flow rate  $\dot{m}_f$  for the range  $4 \leq \dot{m}_f \leq 6$  kg/s based upon the length/pass found in part (c), (d) the effect of  $\pm 10\%$  change in the water flow rate,  $\dot{m}_w$ , on  $T_{f,o}$  and (e) the effect of  $\pm 3^\circ\text{C}$  change in inlet water temperature,  $T_{w,i}$ , on  $T_{f,o}$ . For parts (c, d, e), account for any changes in the overall convection coefficient, while all other conditions remain the same.

**SCHEMATIC:**

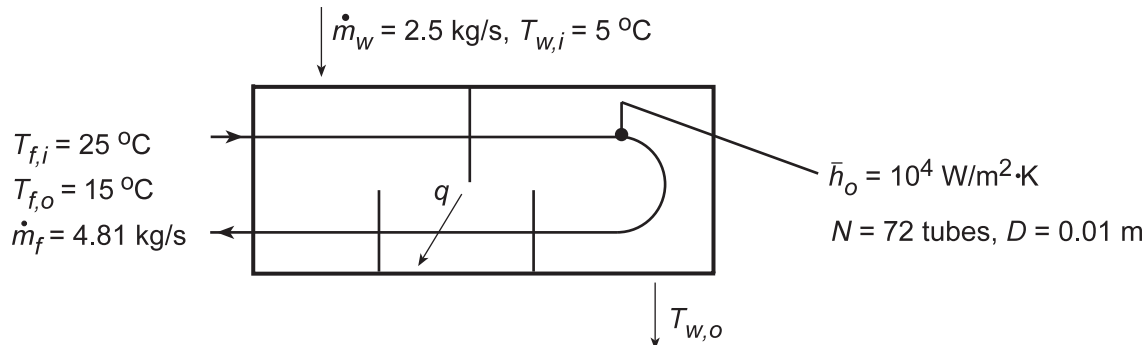

**ASSUMPTIONS:** (1) Negligible heat loss to surroundings, fouling and tube wall resistance; (2) Constant properties; (3) Fully developed flow, (4) Convection coefficient on shell side,  $\bar{h}_o$ , remains constant for all operating conditions.

**PROPERTIES:** Coolant (given):  $c_p = 1040$  J/kg·K,  $\mu = 7.65 \times 10^{-4}$  kg/s·m,  $k = 0.058$  W/m·K,  $Pr = 14$ ; Water (given):  $c_p = 4200$  J/kg·K.

**ANALYSIS:** (a) For flow through a single tube,

$$Re_D = \frac{4\dot{m}_{f,t}}{\pi D \mu} = \frac{4(4.81 \text{ kg/s})/72}{\pi(0.01 \text{ m})7.65 \times 10^{-4} \text{ kg/s} \cdot \text{m}} = 11,120$$

and using the Dittus-Boelter correlation, find

$$h_i = (k/D)0.023 Re_D^{4/5} Pr^{0.3} = 0.023 \frac{0.058 \text{ W/m} \cdot \text{K}}{0.01 \text{ m}} (11,120)^{4/5} (14)^{0.3} = 508 \text{ W/m}^2 \cdot \text{K} <$$

(b) Find the capacity ratio

$$C_f = \dot{m}_f c_{p,f} = 4.81 \text{ kg/s} (1040 \text{ J/kg} \cdot \text{K}) = 5002 \text{ W/K} = C_{\min}$$

$$C_w = \dot{m}_w c_{p,w} = 2.5 \text{ kg/s} (4200 \text{ J/kg} \cdot \text{K}) = 10,500 \text{ W/K} = C_{\max}$$

hence,  $C_r = C_{\min}/C_{\max} = 0.476$  and

$$\varepsilon = \frac{q}{q_{\max}} = \frac{C_f (T_{f,i} - T_{f,o})}{C_f (T_{f,i} - T_{w,i})} = \frac{(25 - 15)^\circ \text{C}}{(25 - 5)^\circ \text{C}} = 0.500.$$

Using Fig. 11.12 with  $NTU = (UA/C_{\min}) = (UN\pi D^2 L/C_{\min}) \approx 0.85$ ,

Continued...

**PROBLEM 11.50 (Cont.)**

$$U = (h_i^{-1} + h_o^{-1})^{-1} = \left[ (508)^{-1} + (10^4)^{-1} \right]^{-1} \text{ W/m}^2 \cdot \text{K} = 483 \text{ W/m}^2 \cdot \text{K}$$

$$L = 0.85(5002 \text{ W/K}) / 144\pi (483 \text{ W/m}^2 \cdot \text{K}) 0.01 \text{ m} = 1.95 \text{ m} .$$

<

(c) Using the *IHT Heat Exchanger Tool, Shell and Tube, One-shell pass and N-tube passes*, and the *Correlation Tool, Forced Convection, Internal Flow for Turbulent, fully developed conditions*, a model was developed using the effectiveness-NTU method employed above to compute and plot  $T_{f,o}$  as a function of  $\dot{m}_f$ .

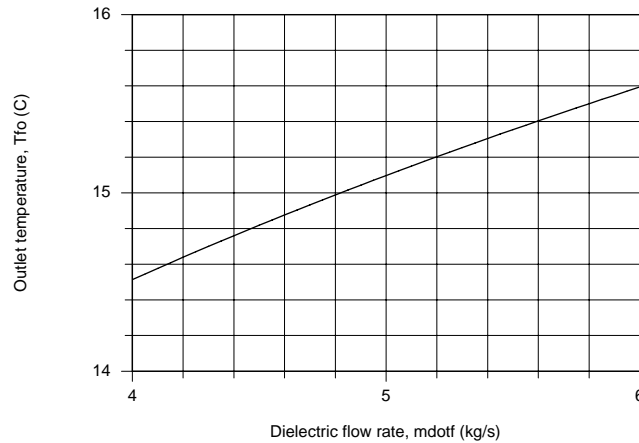

A change in the dielectric fluid flow rate of  $\pm 1$  kg/s causes approximately  $\pm 0.5^\circ\text{C}$  change in its outlet temperature.

(d) Using the above IHT model with the base conditions for part (c), the effect of a  $\pm 10\%$  change in the water flow rate from its design value,  $\dot{m}_w = 2.5$  kg/s ( $2.25 \leq \dot{m}_w \leq 2.75$  kg/s) causes the dielectric fluid outlet temperature to change as

$$T_{f,o} = 15 \pm 0.14^\circ\text{C}$$

<

(e) Using the IHT model of part (c) with the base case conditions for part (c), the effect of a  $\pm 3^\circ\text{C}$  in the water inlet temperature from its design value,  $T_{c,i} = 5^\circ\text{C}$  ( $2 \leq T_{c,i} \leq 8^\circ\text{C}$ ) cause the dielectric fluid outlet temperature to change as

$$T_{f,o} = 15 \pm 1.5^\circ\text{C}$$

<

**COMMENTS:** (1) For the analyses of part (a), Eq. 11.30b,c yields  $\text{NTU} = 0.85$  and  $q = 50$  kW and  $T_{w,o} = 9.76^\circ\text{C}$ .

(2) The results of the analyses provide operating performance information on the effect of changes due to dielectric fluid flow rate ( $\pm 1$  kg/s of  $\dot{m}_f$ ), water fluid flow rate ( $\leq 10\%$  of  $\dot{m}_w$ ) and water inlet temperature ( $\pm 3^\circ\text{C}$  of  $T_{w,i}$ ) on the dielectric fluid outlet temperature,  $T_{f,o}$ , supplied to the computer. The greatest effect on  $T_{f,o}$ , is that by the input water temperature.

## PROBLEM 11.51

**KNOWN:** Inlet temperatures of brine and working fluid in a geothermal power plant heat exchanger. Brine outlet temperature. Electric power generation and thermal efficiency of the geothermal plant. Overall heat transfer coefficients under clean and fouled conditions.

**FIND:** (a) Brine flow rate, heat exchanger effectiveness, required heat transfer surface area for clean conditions. (b) Electric power generated under fouled conditions.

**SCHEMATIC:**

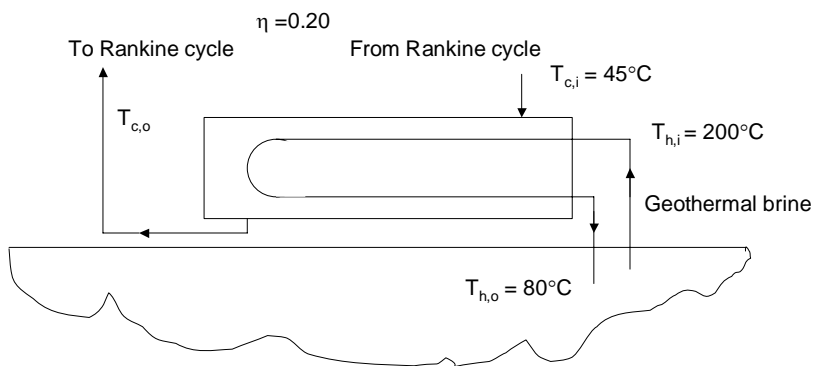

**ASSUMPTIONS:** (1) Negligible heat transfer between heat exchanger and surroundings, (2) Constant properties.

**PROPERTIES:** Table A.6 brine (water),  $\bar{T} = 140^\circ\text{C}$ :  $c_p = 4285 \text{ J/kg}\cdot\text{K}$ .

**ANALYSIS:** (a) The heat input to the working fluid of the Rankine cycle is supplied from the heat exchanger and is  $q = P/\eta = 25 \times 10^6 \text{ W}/0.20 = 125 \times 10^6 \text{ W}$ . Therefore, the required brine flow rate is

$$\dot{m} = q/[c_p(T_{h,i} - T_{h,o})] = 125 \times 10^6 \text{ W}/[4285 \text{ J/kg}\cdot\text{K} \times (200^\circ\text{C} - 80^\circ\text{C})] = 243 \text{ kg/s} \quad <$$

and  $C_{\min} = \dot{m}c_p = 243 \text{ kg/s} \times 4285 \text{ J/kg}\cdot\text{K} = 1.04 \times 10^6 \text{ W/K}$ . The required effectiveness is

$$\varepsilon = q/[C_{\min}(T_{h,i} - T_{c,i})] = 125 \times 10^6 \text{ W}/[1.04 \times 10^6 \text{ W/K}(200^\circ\text{C} - 45^\circ\text{C})] = 0.775 \quad <$$

From Fig. 11.12, the NTU is 1.5 and  $A = \text{NTU} \cdot C_{\min}/U = (1.5 \times 1.04 \times 10^6 \text{ W/K})/4000 \text{ W/m}^2\cdot\text{K} = 390 \text{ m}^2$ . <

(b) Under fouled conditions,  $\text{NTU} = UA/C_{\min} = 2000 \text{ W/m}^2\cdot\text{K} \times 390 \text{ m}^2/(1.04 \times 10^6 \text{ W/m}^2\cdot\text{K}) = 0.75$ . From Fig. 11.12, the effectiveness is  $\varepsilon = 0.55$ . Hence,  $q = \varepsilon C_{\min}(T_{h,i} - T_{c,i}) = 0.55 \times 1.04 \times 10^6 \text{ W/K} \times (200^\circ - 45^\circ\text{C}) = 88.7 \times 10^6 \text{ W}$  and the electric power generated is  $P = \eta q = 0.20 \times 88.7 \times 10^6 \text{ W} = 17.7 \times 10^6 \text{ W} = 17.7 \text{ MW}$  (electric). <

**COMMENTS:** (1) With this analysis, the electric power output is reduced by  $[(25 - 17.7)/25] \times 100 = 29\%$  due to fouling. (2) The outlet brine temperature as well as the inlet Rankine fluid temperature would also change as a result of fouling. A more accurate estimate of the effect of fouling would require coupling the heat transfer analysis with an analysis of the Rankine cycle and its components. (3) Use of Eq. 11.35b yields  $\text{NTU} = 1.49$  in part (a) and  $\varepsilon = 0.525$  and  $P = 17.0 \text{ MW}$  in part (b). (4) See Tester et al., "Impact of Enhanced Geothermal Systems on U.S. Energy Supply in the Twenty-First Century," *Philosophical Transactions of the Royal Society A*, Vol. 365, pp. 1057 – 1094, 2007 for a discussion of the geothermal energy potential in the United States.

## PROBLEM 11.52

**KNOWN:** Warm water flow rate and temperature. Cold water flow rate and temperature. Configuration of a shell-and-tube heat exchanger including number of tube passes, number of tubes, and tube length and tube diameter. Outside heat transfer coefficient during melting of the phase change material. Duration of melting.

**FIND:** (a) Volume of phase change material melted over a 12-hour period. Diameter of shell. (b) Heat transfer rate during solidification of phase change material relative to heat transfer rate in part (a).

**SCHEMATIC:**

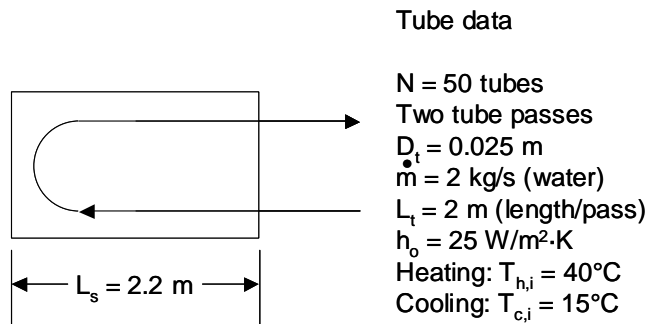

**ASSUMPTIONS:** (1) Negligible heat transfer between heat exchanger and surroundings, (2) Negligible fouling effects, (3) Negligible wall resistance, (4) Negligible convective resistance on inside of tubing, (5) Negligible sensible energy change in phase change material, (6) Constant properties.

**PROPERTIES:** *n*-octadecane (Problem 8.47):  $T_f = 27.4^\circ\text{C}$ ,  $h_{sf} = 244$  kJ/kg,  $\rho = 770$  kg/m<sup>3</sup>. Table A.6 (water) ( $\bar{T} = 27^\circ\text{C} = 300$  K):  $c_p = 4179$  J/kg·K.

**ANALYSIS:** (a) With no change in the *n*-octadecane temperature, the minimum heat rate is associated with the water and is  $C_{\min} = C_h = \dot{m}c_p = 2\text{ kg/s} \times 4179$  J/kg·K = 8358 W/K. The heat transfer area is  $A = 2N(\pi D_t L_t) = 2 \times 50 \times (\pi \times 0.025$  m  $\times 2\text{ m}) = 15.7$  m<sup>2</sup>. For negligible convective and tube wall resistances and negligible fouling effects,  $U = h_o = 25$  W/m<sup>2</sup>·K. Therefore,  $\text{NTU} = UA/C_{\min} = (25$  W/m<sup>2</sup>·K  $\times 15.7$  m<sup>2</sup>)/8358 W/K = 0.047. The effectiveness is

$$\varepsilon = 1 - \exp(-\text{NTU}) = 1 - \exp(-0.047) = 0.0458.$$

and the heat transfer rate is

$$q = \varepsilon C_{\min} (T_{h,i} - T_f) = 0.0458 \times 8358 \text{ W/K} \times (40 - 27.4)^\circ\text{C} = 4823 \text{ W}$$

Over a 12-hour period, the volume of phase change material that is melted is

$$V_{pcm} = qt / (\rho h_{s,f}) = (4823 \text{ W} \times 12 \text{ h} \times 60 \text{ min/h} \times 60 \text{ s/min}) / (770 \text{ kg/m}^3 \times 244 \times 10^3 \text{ J/kg}) = 1.11 \text{ m}^3 <$$

so the total volume of phase change material in the shell is  $V_{\text{tot}} = 1.5 \times 1.11 \text{ m}^3 = 1.66 \text{ m}^3$ .

Continued...

### PROBLEM 11.52 (Cont.)

The total shell volume is occupied by (i) phase change material and (ii) tubing. The tubing volume is

$$V_{tub} = 2NL_t(\pi D_t^2 / 4) = 2 \times 50 \times 2\text{m} \times (\pi [0.025\text{m}]^2 / 4) = 0.098\text{m}^3$$

Therefore, the shell diameter is

$$D_s = \sqrt{\frac{4(V_{tub} + V_{pcm})}{\pi L_s}} = \sqrt{\frac{4(0.098\text{m}^3 + 1.66\text{m}^3)}{\pi \times 2.2\text{m}}} = 1.0\text{ m} \quad <$$

(b) The difference between the water temperature and the melting temperature of the phase change material is approximately 12.5 degrees Celsius for both heating and cooling modes. However, during solidification of the phase change material, the solid phase will form adjacent to the cold tube wall. Since the thermal conductivity of the phase change material is small ( $k = 0.653\text{ W/m}\cdot\text{K}$ ; Problem 8.47) we expect the conduction resistance posed by the solid material to be very large and will increase as the solidification ensues. Hence, the overall heat transfer coefficient,  $U$ , will be much smaller during solidification and the overall heat transfer rate will be much smaller relative to that of part (a).

<

**COMMENTS:** (1) Evaluating water properties at  $40^\circ\text{C}$  and for  $N = 50$  tubes,  $Re_D = 4\dot{m}/(N\pi D\mu) = 3100$ ,  $Nu_D = 22.2$  and  $h_i = 560\text{ W/m}^2\cdot\text{K}$  using the Dittus-Boelter relationship of Chapter 8. Since  $h_i \gg h_o$ , the assumption of negligible convection resistance on the inside of the tube is reasonable. (2) The outlet temperature of the warm water is

$$T_{h,o} = T_{h,i} - q/C_{\min} = 40^\circ\text{C} - 4823\text{W}/8358\text{K/W} = 39.4^\circ\text{C}$$

(3) During melting, the value of the overall heat transfer coefficient will vary with time as the distance between the warm tube wall and the solid-liquid interface increases. (4) A detailed analysis would be necessary to determine the time-variation of the overall heat transfer coefficient, particularly when operating in the solidification mode.

### PROBLEM 11.53

**KNOWN:** Shell and tube heat exchanger with 135 tubes (one shell, double pass) of inner diameter 12.5 mm and surface area 47.5 m<sup>2</sup>.

**FIND:** (a) Exchanger gas and water outlet temperatures, (b) Tube heat transfer coefficient,  $\bar{h}_i$ , assuming fully developed flow, (c) Compute and plot the effectiveness and fluid outlet temperatures,  $T_{c,o}$  and  $T_{h,o}$  for the water flow rate range  $6 \leq \dot{m}_c \leq 12$  kg/s with all other conditions remaining the same, and (d) Hot gas inlet temperature,  $T_{h,i}$ , required to supply 10 kg/s of hot water with an outlet temperature of 42°C with all other conditions the same; determine also the effectiveness.

**SCHEMATIC:**

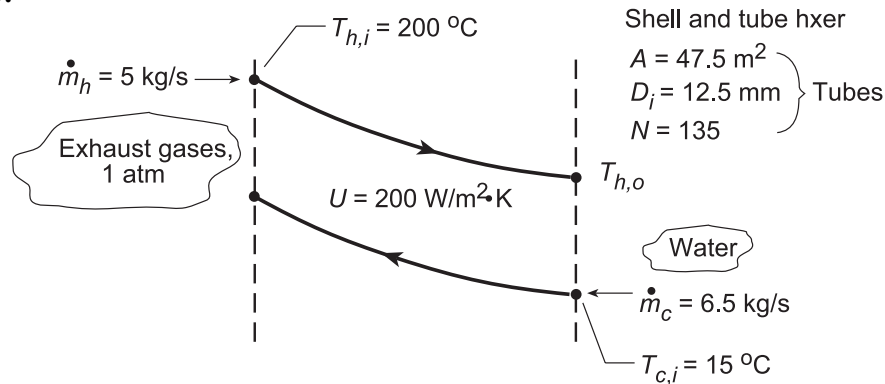

**ASSUMPTIONS:** (1) Negligible heat lost to surroundings, (2) Fully-developed conditions for internal flow of water in tubes, (3) Exhaust gas properties are those of air, and (4) The overall coefficient remains unchanged for the operating conditions examined.

**PROPERTIES:** Table A-6, Water ( $\bar{T}_c \approx 300$  K):  $\rho = 997$  kg/m<sup>3</sup>,  $c = 4179$  J/kg·K,  $k = 0.613$  W/m·K,  $\mu = 855 \times 10^{-6}$  N·s/m<sup>2</sup>,  $Pr = 5.83$ ; Table A-4, Air (1 atm,  $\bar{T}_h \approx 400$  K):  $\rho = 0.8711$  kg/m<sup>3</sup>,  $c = 1014$  J/kg·K.

**ANALYSIS:** (a) Using the  $\epsilon$ -NTU method, first find the capacity rates,  $C = \dot{m}c$ ,

$$C_c = 6.5 \text{ kg/s} \times 4179 \text{ J/kg} \cdot \text{K} = 27,164 \text{ W/K} \quad C_h = 5.0 \text{ kg/s} \times 1014 \text{ J/kg} \cdot \text{K} = 5,070 \text{ W/K}.$$

Recognize that  $C_h = C_{\min}$  and determine

$$\frac{C_{\min}}{C_{\max}} = \frac{C_h}{C_c} = \frac{5,070}{27,164} = 0.19 \quad NTU = \frac{AU}{C_{\min}} = \frac{47.5 \text{ m}^2 \times 200 \text{ W/m}^2 \cdot \text{K}}{5,070 \text{ W/K}} = 1.87.$$

From Fig. 11.12 for the shell and tube exchanger, find with  $NTU = 1.87$  and  $C_{\min}/C_{\max} = 0.19$  that  $\epsilon \approx 0.78$ . From the definition of effectiveness,

$$\epsilon = \frac{q}{q_{\max}} = \frac{C_h (T_{h,i} - T_{h,o})}{C_{\min} (T_{h,i} - T_{c,i})} = \frac{200 - T_{h,o}}{200 - 15} = 0.78 \quad \text{or} \quad T_{h,o} = 55.7^\circ \text{C}. \quad <$$

From energy balances on the two fluids,  $C_h (T_{h,i} - T_{h,o}) = C_c (T_{c,o} - T_{c,i})$ , find

$$T_{c,o} = T_{c,i} + (C_h/C_c)(T_{h,i} - T_{h,o}) = 15^\circ \text{C} + 0.19(200 - 55.7)^\circ \text{C} = 41.9^\circ \text{C}. \quad <$$

(b) To estimate  $\bar{h}_i$  for the water, find first the Reynolds number. From Eq. 8.6,

Continued...

**PROBLEM 11.53 (Cont.)**

$$\text{Re}_{D_i} = \frac{4\dot{m}}{\pi D_i \mu} = \frac{4\dot{m}_C / N}{\pi D_i \mu} = \frac{4 \times 6.5 \text{ kg/s} / 135}{\pi 12.5 \times 10^{-3} \text{ m} \times 855 \times 10^{-6} \text{ N/s} \cdot \text{m}^2} = 5736$$

While the flow is fully developed and turbulent,  $\text{Re}_D = 10,000$  such that Dittus-Boelter correlation is not strictly applicable. However, its use allows a first estimate.

$$\overline{\text{Nu}}_{D_i} = \bar{h} D_i / k = 0.023 \text{Re}_D^{4/5} \text{Pr}^{0.4} = 0.023 (5736)^{4/5} (5.83)^{0.4} = 47.3$$

$$\bar{h}_i = \overline{\text{Nu}}_D k / D_i = 47.3 \times 0.613 \text{ W/m}^2 \cdot \text{K} / 12.5 \times 10^{-3} \text{ m} = 2320 \text{ W/m}^2 \cdot \text{K} .$$

<

(c) Using the *IHT Heat Exchanger Tool, Shell and Tube, One-shell pass and N-tube passes*, and the prescribed properties, a model was developed following the analysis of part (a) to compute and plot  $\epsilon$ ,  $T_{c,o}$ , and  $T_{h,o}$  for a function of  $\dot{m}_C$ .

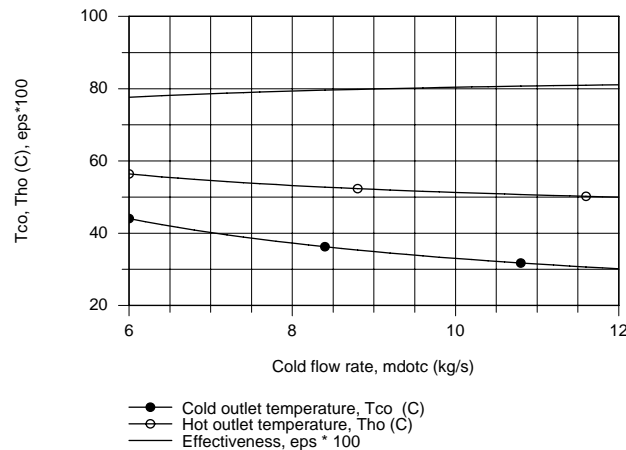

The outlet temperatures decrease nearly linearly with increasing cold fluid flow rate; the decrease in the cold outlet temperature is nearly twice that of the hot fluid. The change in the effectiveness with increasing flow rate is only slightly increased.

(d) Using the above IHT model, the hot inlet temperature  $T_{h,i}$ , required to provide  $\dot{m}_C = 10 \text{ kg/s}$  with  $T_{c,o} = 42^\circ\text{C}$  and the effectiveness for this operating condition are

$$T_{h,i} = 74.4^\circ\text{C} \quad \epsilon = 0.55$$

<

**COMMENTS:** (1) Check that assumptions for  $\bar{T}_h$  and  $\bar{T}_c$  used in part (a) for evaluation of the fluid properties are satisfactory as  $\bar{T}_h = 400.7 \text{ K}$  and  $\bar{T}_c = 301.5 \text{ K}$ .

(2) From part (b), with  $\bar{h}_i = 2320 \text{ W/m}^2 \cdot \text{K}$  and  $U = 200 \text{ W/m}^2 \cdot \text{K}$ , the shell-side convection coefficient is  $\bar{h}_o = 219 \text{ W/m}^2 \cdot \text{K}$ . As such,  $U$  is controlled by shell-side conditions. Assuming  $U$  as a constant in part (c) with changes in  $\dot{m}_C$  is therefore reasonable. However, for part (d) with  $\dot{m}_h$  doubling, we should expect  $U$  to increase.



### PROBLEM 11.54

**KNOWN:** Power output and efficiency of an ocean energy conversion system. Temperatures and overall heat transfer coefficient of shell-and-tube evaporator.

**FIND:** (a) Evaporator area, (b) Water flow rate.

**SCHEMATIC:**

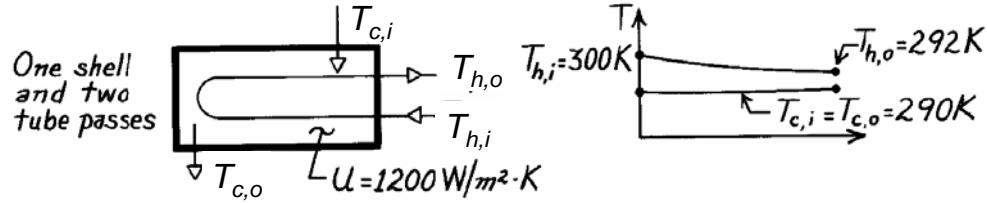

**ASSUMPTIONS:** (1) Negligible heat loss to surroundings, (2) Constant properties.

**PROPERTIES:** Table A-6, Water ( $\bar{T}_m = 296 \text{ K}$ ):  $c_p = 4181 \text{ J/kg}\cdot\text{K}$ .

**ANALYSIS:** (a) The efficiency is

$$\eta = \frac{\dot{W}}{q} = \frac{2 \text{ MW}}{q} = 0.03.$$

Hence the required heat transfer rate is  $q = \frac{2 \text{ MW}}{0.03} = 66.7 \text{ MW}$ .

From the  $\varepsilon$ -NTU method,  $C_c \rightarrow \infty$ , and  $C_h = C_{\min}$  can be found from an energy balance on the hot fluid,

$$C_h = q / (T_{h,i} - T_{h,o}) = 66.7 \times 10^6 \text{ W} / (300 - 292) \text{ K} = 8.33 \times 10^6 \text{ W/K}$$

Thus  $q_{\max} = C_{\min}(T_{h,i} - T_{c,i}) = 8.33 \times 10^7 \text{ W}$  and  $\varepsilon = q/q_{\max} = 0.80$ . Then, from Eqs. 11.30 b and c,

$$E = \frac{2/\varepsilon - (1 + C_r)}{(1 + C_r^2)^{1/2}} = \frac{2/0.8 - (1 + 0)}{1} = 1.50$$

$$\text{NTU} = -\left(1 + C_r^2\right)^{-1/2} \ln\left(\frac{E-1}{E+1}\right) = -\ln\left(\frac{1.5-1}{1.5+1}\right) = 1.61$$

Then,  $A = \text{NTU} \times C_{\min}/U = 1.61 \times 8.33 \times 10^6 \text{ W/K} / 1200 \text{ W/m}^2\cdot\text{K} = 11,200 \text{ m}^2$  <

(b) The water flow rate through the evaporator is

$$\dot{m}_h = \frac{q}{c_{p,h}(T_{h,i} - T_{h,o})} = \frac{6.67 \times 10^7 \text{ W}}{4181 \text{ J/kg}\cdot\text{K}(300 - 292)}$$

$$\dot{m}_h = 1994 \text{ kg/s.} <$$

**COMMENT:** (1) The required heat exchanger size is enormous due to the small temperature differences involved.

## PROBLEM 11.55

**KNOWN:** Single-pass cross-flow heat exchanger with both fluids unmixed. Flow rate and inlet and outlet temperatures of cold water. Inlet temperature of hot exhaust gases. Value of UA.

**FIND:** Required mass flow rate of exhaust gases.

**SCHEMATIC:**

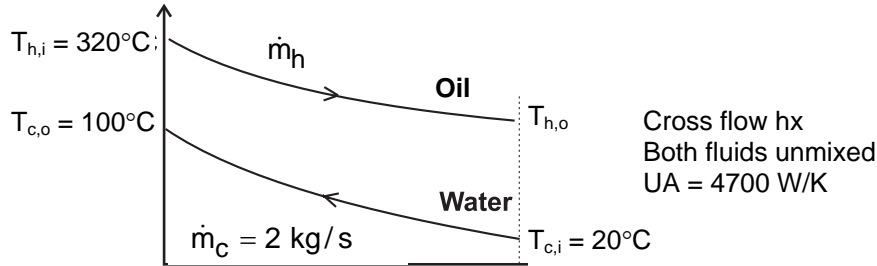

**ASSUMPTIONS:** (1) Constant properties and steady-state conditions, (2) Negligible heat loss to surroundings, (3) U independent of mass flow rates.

**PROPERTIES:** Water (given):  $c_{p,c} = 4200 \text{ J/kg}\cdot\text{K}$ . Oil (given):  $c_{p,h} = 1200 \text{ J/kg}\cdot\text{K}$ .

**ANALYSIS:** We use the  $\varepsilon$ -NTU method, but without knowing the hot mass flow rate or the hot outlet temperature we don't know which fluid is the minimum fluid. We begin by assuming the cold fluid is the minimum fluid: if this leads to a solution for which the cold heat capacity rate is indeed lower than for the hot fluid, this is the correct solution. If it does not lead to a consistent solution, our assumption is incorrect. Thus, we assume

$$C_{\min} = \dot{m}_c c_{p,c} = 2 \text{ kg/s} \times 4200 \text{ J/kg}\cdot\text{K} = 8400 \text{ W/K}$$

Thus,  $\text{NTU} = UA/C_{\min} = 4700/8400 = 0.560$ ,  $q = C_c(T_{c,o} - T_{c,i}) = 6.72 \times 10^5 \text{ W}$  and from Eqs. 11.18 and 11.19,

$$\varepsilon = \frac{q}{C_{\min}(T_{h,i} - T_{c,i})} = \frac{6.72 \times 10^5 \text{ W}}{8400 \text{ W/K} (320 - 20)^\circ\text{C}} = 0.267$$

Referring to Figure 11.14, we see that there is no solution for  $\text{NTU} = 0.560$ ,  $\varepsilon = 0.267$ , therefore our initial assumption was incorrect and the hot fluid is the minimum fluid. We have the following four equations relating the four unknowns  $\varepsilon$ ,  $C_{\min}$ , NTU, and  $C_r$ ,

$$\varepsilon = \frac{q}{C_{\min}(T_{h,i} - T_{c,i})} = \frac{6.72 \times 10^5 \text{ W}}{C_{\min}(320 - 20)^\circ\text{C}} = \frac{2240 \text{ W/K}}{C_{\min}} \quad (1)$$

$$\text{NTU} = \frac{UA}{C_{\min}} = \frac{4700 \text{ W/K}}{C_{\min}}, \quad C_r = \frac{C_{\min}}{C_{\max}} = \frac{C_{\min}}{8400 \text{ W/K}} \quad (2,3)$$

and from Eq. 11.32,

Continued...

**PROBLEM 11.55 (Cont.)**

$$\varepsilon = 1 - \exp \left[ \left( \frac{1}{C_r} \right) (\text{NTU})^{0.22} \left\{ \exp \left[ -C_r (\text{NTU})^{0.78} \right] - 1 \right\} \right] \quad (4)$$

These equations can be solved simultaneously using *IHT*, or by hand. One approach to solving the equations by hand is as follows. Substituting Eqs. (1), (2), and (3) into Eq. (4) yields (where the units have been omitted),

$$\frac{2240}{C_{\min}} = 1 - \exp \left[ \frac{8400}{C_{\min}} \left( \frac{4700}{C_{\min}} \right)^{0.22} \left\{ \exp \left[ -\frac{C_{\min}}{8400} \left( \frac{4700}{C_{\min}} \right)^{0.78} \right] - 1 \right\} \right]$$

Beginning with an assumed value of  $C_{\min}$  and substituting it into the right hand side, we solve for  $C_{\min}$  on the left hand side, and repeat the process until it converges. Beginning with  $C_{\min} = 5000$ , the sequence of  $C_{\min}$  values is 5000, 4375, 3984, 3745, 3601, 3515, 3463, 3434, 3416, 3406, 3400, 3396, 3394, 3393, 3392, 3392. Thus

$$\dot{m}_h = C_{\min} / c_{p,h} = 3392 \text{ W/K} / 1200 \text{ J/kg} \cdot \text{K} = 2.83 \text{ kg/s} \quad <$$

**COMMENTS:** It is easier to solve the system of simultaneous equations using *IHT* or other non-linear equation solver.

## PROBLEM 11.56

**KNOWN:** Shell(1)-and-tube (two passes,  $p = 2$ ) heat exchanger for condensing saturated steam at 1 atm. Inlet cooling water temperature and mean velocity. Thin-walled tube diameter and length prescribed, as well as, convective heat transfer coefficient on outer tube surface,  $h_o$ .

**FIND:** (a) Number of tubes/pass,  $N$ , required to condense 2.3 kg/s of steam, (b) Outlet water temperature,  $T_{c,o}$ , (c) Maximum condensation rate possible for same water flowrate and inlet temperature, and (d) Compute and plot  $T_{c,o}$  and the condensation rate,  $\dot{m}_h$ , for water mean velocity,  $u_m$ , in the range  $1 \leq u_m \leq 5$  m/s, using the heat transfer surface area found in part (a) assuming the shell-side convection coefficient remains unchanged.

**SCHEMATIC:**

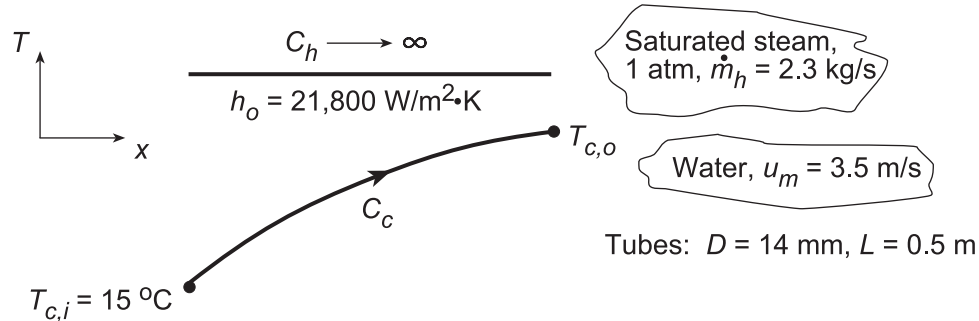

**ASSUMPTIONS:** (1) Negligible heat loss to surroundings, (2) Negligible thermal resistance due to the tube walls.

**PROPERTIES:** Table A.6, Saturated steam (1 atm):  $T_{\text{sat}} = 100^\circ\text{C}$ ,  $h_{\text{fg}} = 2257$  kJ/kg; Water (assume  $T_{c,o} \approx 25^\circ\text{C}$ ,  $\bar{T}_m = (T_h + T_c)/2 \approx 295$  K):  $\rho = 1/v_f = 998$  kg/m<sup>3</sup>,  $c_c = c_{p,f} = 4181$  J/kg·K,  $\mu = \mu_f = 959 \times 10^{-6}$  N·s/m<sup>2</sup>,  $k = k_f = 0.606$  W/m·K,  $\text{Pr} = \text{Pr}_f = 6.62$ .

**ANALYSIS:** (a) The heat transfer rate for the heat exchanger is

$$q = \dot{m}_h h_{\text{fg}} = 2.3 \text{ kg/s} \times 2257 \times 10^3 \text{ J/kg} = 5.191 \times 10^6 \text{ W} \quad (1)$$

Using the  $\varepsilon$ -NTU method, evaluate the following parameters:

Water-side heat transfer coefficient:

$$\text{Re}_D = \frac{u_m D}{\mu / \rho} = \frac{3.5 \text{ m/s} \times 0.014 \text{ m}}{959 \times 10^{-6} \text{ N} \cdot \text{s} / \text{m}^2 / 998 \text{ kg} / \text{m}^3} = 50,993 \quad (2)$$

$$h_i = \frac{k}{D} \text{Nu}_D = \frac{k}{D} 0.023 \text{Re}_D^{0.8} \text{Pr}^{0.4} = \frac{0.606 \text{ W/m} \cdot \text{K}}{0.014 \text{ m}} \times 0.023 (50,993)^{0.8} (6.62)^{0.4} = 12,400 \text{ W/m}^2 \cdot \text{K} \quad (3)$$

using the Dittus-Boelter equation for fully developed turbulent conditions.

Overall coefficient:

$$\bar{U} = (1/h_i + 1/h_o)^{-1} = (1/12,400 + 1/21,800)^{-1} = 7900 \text{ W/m}^2 \cdot \text{K} \quad (4)$$

Effectiveness relations: With  $C_{\text{min}} = C_c$  and  $\dot{m}_c = \rho(\pi D^2/4)u_m N$ ,

$$q = \varepsilon q_{\text{max}} = \varepsilon C_{\text{min}} (T_{h,i} - T_{c,i}) \quad (5)$$

$$C_{\text{min}} = \dot{m}_c c_c = 998 \text{ kg/m}^3 \left( \pi \times 0.014^2 \text{ m}^2 / 4 \right) \times 3.5 \text{ m/s} \times N \times 4181 \text{ J/kg} \cdot \text{K} = 2248 N \quad (6)$$

Continued...

### PROBLEM 11.56 (Cont.)

$$5.191 \times 10^6 \text{ W} = \varepsilon \times 2248 \text{ N} (100 - 15) \text{ K}$$

$$\varepsilon \text{ N} = 27.17 \tag{7}$$

From Eq. 11.35a with  $C_r = 0$ , the effectiveness is

$$\varepsilon = 1 - \exp(-\text{NTU}) = 1 - \exp(-0.155) = 0.144 \tag{8}$$

where, using  $A_s = \pi \text{DLNP}$ , NTU is evaluated as,

$$\text{NTU} = \frac{\bar{U} A_s}{C_{\min}} = \frac{7900 \text{ W/m}^2 \cdot \text{K} (\pi \times 0.014 \text{ m} \times 0.5 \text{ m}) \text{ N} \times 2}{2248 \text{ N}} = 0.155$$

Hence, using Eq. (7), the required number of tubes is

$$N = 27.17 / \varepsilon = 205.8 \approx 189 \tag{9}$$

and the total surface area is

$$A_s = \pi \text{DLNP} = \pi \times 0.014 \text{ m} \times 0.5 \text{ m} \times 189 \times 2 = 8.31 \text{ m}^2.$$

(b) The water outlet temperature with  $C_{\min} = 2248 \text{ N} = 424,900 \text{ W/K}$ ,

$$T_{c,o} = T_{c,i} + q / C_{\min} = 15^\circ \text{C} + 5.191 \times 10^6 \text{ W} / 424,900 \text{ W/K} = 27.2^\circ \text{C} \tag{10}$$

(c) The maximum condensation rate will occur when  $q = q_{\max}$ . Hence

$$\dot{m}_{h,\max} = \frac{q_{\max}}{h_{fg}} = \frac{C_{\min} (T_{h,i} - T_{c,i})}{h_{fg}} = \frac{424,900 \text{ W/K} (100 - 15) \text{ K}}{2257 \times 10^3 \text{ J/kg}} = 16.0 \text{ kg/s}. \tag{11}$$

(d) Using the *IHT Heat Exchanger Tool, All Exchangers*,  $C_r = 0$ , along with the *Properties Tool* for *Water*, the foregoing analysis was performed to obtain  $T_{h,o}$  and  $\dot{m}_h$  using the heat transfer surface area  $A_s = 8.31 \text{ m}^2$  (part a) as a function of  $u_m$ .

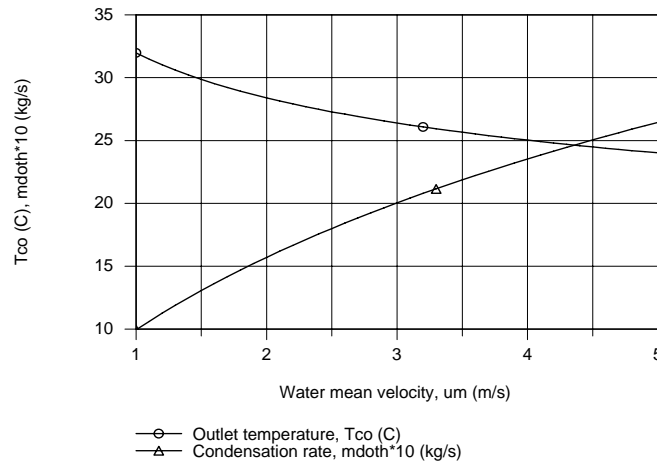

Note that the condensation rate increases nearly linearly with the water mean velocity. The cold water outlet temperature decreases nearly linearly with  $u_m$ . We should expect this behavior from energy balance considerations. Since  $h_h$  is nearly two times greater than  $h_c$ ,  $\bar{U}$  is controlled by the water side coefficient. Hence  $\bar{U}$  will increase with increasing  $u_m$ .

**COMMENTS:** Note that the assumed value for  $\bar{T}_m$  to evaluate water properties in part (a) was a good choice.

## PROBLEM 11.57

**KNOWN:** Dimensions of counterflow, concentric tube heat exchanger for recovering heat from shower drains. Inlet temperatures of hot and cold water streams. Heat transfer coefficient of inner (hot) flow. Mass flow rate of outer (cold) flow.

**FIND:** (a) Heat transfer rate and outlet temperature of cold flow, (b) Heat transfer rate and outlet temperature of cold flow when helical spring provides specified outer heat transfer coefficient, (c) Daily savings if 15,000 students each take a 10-minute shower per day and cost of heating water is \$0.07/kW·h.

**SCHEMATIC:**

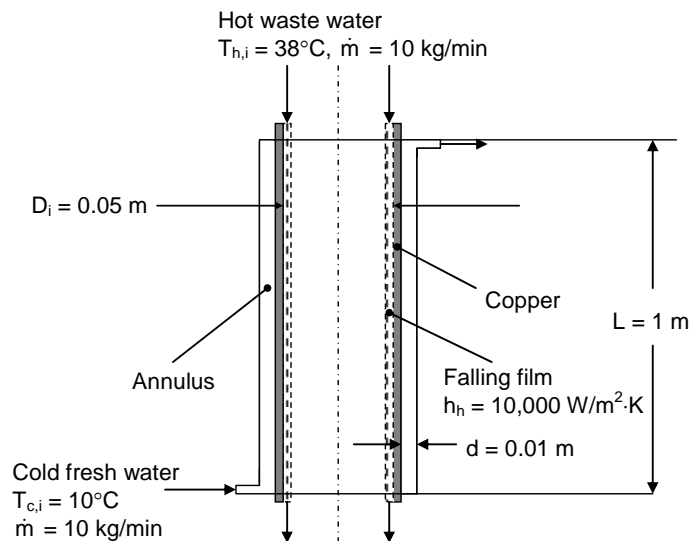

**ASSUMPTIONS:** (1) Constant properties and steady-state conditions, (2) Negligible heat transfer to surroundings, (3) Fully developed flow in the annular gap, (4) Uniform surface temperature correlation is appropriate, (5) Inner tube wall thermal resistance is negligible.

**PROPERTIES:** Table A.6, water ( $T \approx 285$  K):  $k = 0.591$  W/m·K,  $c_p = 4189$  J/kg·K,  $\mu = 1225 \times 10^{-6}$  N·s/m<sup>2</sup>,  $Pr = 8.81$ .

**ANALYSIS:** (a) We begin by finding the heat transfer coefficient for the flow in the annular gap. The Reynolds number is

$$Re_D = \frac{\rho u_m D_h}{\mu} = \frac{\dot{m} D_h}{\mu A_c} = \frac{4\dot{m}}{\mu P} = \frac{4 \times 10 \text{ kg/min} / 60 \text{ min/s}}{1225 \times 10^{-6} \text{ N} \cdot \text{s/m}^2 \times \pi(0.05 \text{ m} + 0.07 \text{ m})} = 1444$$

Thus the flow is laminar, and from Table 8.2 with  $D_i/D_o = 0.71$ ,  $Nu_i = 5.36$ . Hence,

$$h_c = \frac{Nu_i k}{D_h} = \frac{5.36 \times 0.591 \text{ W/m} \cdot \text{K}}{0.02 \text{ m}} = 158 \text{ W/m}^2 \cdot \text{K}$$

Continued...

### PROBLEM 11.57 (Cont.)

Then the overall heat transfer coefficient is

$$U = [1/h_c + 1/h_h]^{-1} = [1/158 \text{ W/m}^2 \cdot \text{K} + 1/10,000 \text{ W/m}^2 \cdot \text{K}]^{-1} = 156 \text{ W/m}^2 \cdot \text{K}$$

and using the  $\varepsilon$ -NTU method, with  $C_{\min} = C_{\max} = \dot{m}c_p = 698 \text{ W/K}$ ,  $C_r = 1$ , we have

$$\text{NTU} = UA/C_{\min} = U\pi D_i L/C_{\min} = 156 \text{ W/m}^2 \cdot \text{K} \times \pi \times 0.05 \text{ m} \times 1 \text{ m}/698 \text{ W/K} = 0.035$$

And from Eq. 11.29a,  $\varepsilon = \text{NTU}/(1 + \text{NTU}) = 0.034$ . Thus from Eqs. 11.18 and 11.19,

$$q = \varepsilon C_{\min}(T_{h,i} - T_{c,i}) = 0.034 \times 698 \text{ W/K} (38 - 10)^\circ\text{C} = 661 \text{ W} \quad <$$

and from Eq. 11.7b,

$$T_{c,o} = T_{c,i} + q/C_c = 10^\circ\text{C} + 661 \text{ W}/698 \text{ W/K} = 11.0^\circ\text{C} \quad <$$

(b) The value of  $U$  changes to  $U = [1/9050 \text{ W/m}^2 \cdot \text{K} + 1/10,000 \text{ W/m}^2 \cdot \text{K}]^{-1} = 4751 \text{ W/K}$ . Then  $\text{NTU} = 1.07$ ,  $\varepsilon = 0.517$ , and

$$q = \varepsilon C_{\min}(T_{h,i} - T_{c,i}) = 0.517 \times 697 \text{ W/K} (38 - 10)^\circ\text{C} = 10,100 \text{ W} \quad <$$

$$T_{c,o} = T_{c,i} + q/C_c = 10^\circ\text{C} + 10,100 \text{ W}/698 \text{ W/K} = 24.5^\circ\text{C} \quad <$$

(c) The savings is the cost of the energy transferred from the wastewater to the cold water,

$$\text{Savings} = 10.1 \text{ kW} \times 600 \text{ s} \times 15,000/3600 \text{ s/h} \times \$0.07/\text{kW}\cdot\text{h} = \$1767 \quad <$$

**COMMENTS:** (1) Commercially-available devices that are used in high density buildings such as dormitories are typically installed on larger drains that collect shower water from multiple showers, rather than on individual showers. The devices use heat transfer enhancement techniques to ensure large values of the cold side heat transfer coefficient. (2) With  $x_{fd,t} = 0.05\text{Re}_D\text{Pr}_h = 13 \text{ m}$ , the flow in the annular gap is not fully developed, and the actual heat transfer coefficient would be higher than predicted in part (a). (3) In part (a), the mean temperature of the cold stream is 283.5 K. Evaluation of properties at 285 K is appropriate.

### PROBLEM 11.58

**KNOWN:** Shell-and-tube heat exchanger with one shell pass and 20 tube passes.

**FIND:** Average convection coefficient for the outer tube surface.

**SCHEMATIC:**

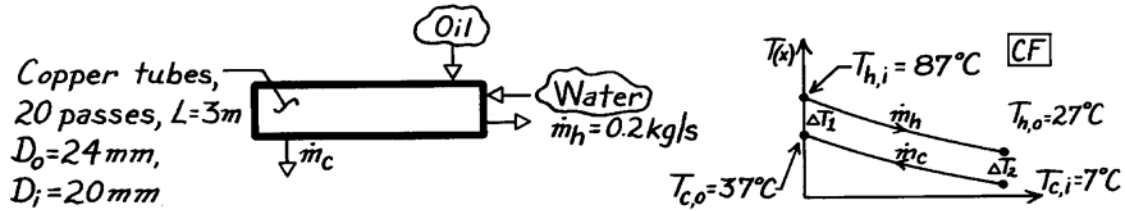

**ASSUMPTIONS:** (1) Negligible heat loss to surroundings, (2) Constant properties, (3) Type of oil not specified, (4) Thermal resistance of tubes negligible; no fouling.

**PROPERTIES:** Table A-6, Water, liquid ( $\bar{T}_h = 330 \text{ K}$ ):  $c_p = 4184 \text{ J/kg}\cdot\text{K}$ ,  $k = 0.650 \text{ W/m}\cdot\text{K}$ ,  $\mu = 489 \times 10^{-6} \text{ N}\cdot\text{s/m}^2$ ,  $\text{Pr} = 3.15$ .

**ANALYSIS:** To find the average coefficient for the outer tube surface,  $h_o$ , we need to evaluate  $h_i$  for the internal tube flow and  $U$ , the overall coefficient. From Eq. 11.5,

$$\frac{1}{UA} = \frac{1}{h_i A_i} + \frac{1}{h_o A_o} = \frac{1}{N_t \pi L} \left[ \frac{1}{h_i D_i} + \frac{1}{h_o D_o} \right]$$

where  $N_t$  is the total number of tubes. Solving for  $h_o$ ,

$$h_o = D_o^{-1} \left[ (UA)^{-1} N_t \pi L - 1/h_i D_i \right]^{-1}. \quad (1)$$

Evaluate  $h_i$  from an appropriate correlation; begin by calculating the Reynolds number.

$$\text{Re}_{D,i} = \frac{4 \dot{m}_h}{\pi D_i \mu} = \frac{4 \times 0.2 \text{ kg/s}}{\pi (0.020 \text{ m}) 489 \times 10^{-6} \text{ N}\cdot\text{s/m}^2} = 26,038.$$

Hence, flow is turbulent and since  $L \gg D_i$ , the flow is likely to be fully developed. Use the Dittus-Boelter correlation with  $n = 0.3$  since  $T_s < T_m$ ,  $\text{Nu}_D = 0.023 \text{ Re}_D^{4/5} \text{ Pr}^{0.3}$

$$h_i = \frac{k}{D} \text{Nu}_D = \frac{0.650 \text{ W/m}\cdot\text{K}}{0.020 \text{ m}} \times 0.023 (26,038)^{4/5} (3.15)^{0.3} = 3594 \text{ W/m}^2 \cdot \text{K}. \quad (2)$$

To evaluate  $UA$ , we use the  $\epsilon$ -NTU method.

$$C_h = \dot{m}_h c_{p,h} = 0.2 \text{ kg/s} \times 4184 \text{ J/kg}\cdot\text{K} = 836.8 \text{ W/K}$$

$$q = C_h (T_{h,i} - T_{h,o}) = 836.8 \text{ W/K} (87 - 27)^\circ\text{C} = 50,208 \text{ W}$$

Then from an energy balance on the cold fluid,

$$C_c = q/(T_{c,o} - T_{c,i}) = 50,208 \text{ W}/(37 - 7)^\circ\text{C} = 1674 \text{ W/K}$$

Thus  $C_r = C_{\min}/C_{\max} = 0.50$ ,  $q_{\max} = C_{\min}(T_{h,i} - T_{c,i}) = 66,944 \text{ W}$ , and  $\epsilon = q/q_{\max} = 0.75$ . From Eqs. 11.30b,c,

Continued...



**PROBLEM 11.58 (Cont.)**

$$E = \frac{2/\varepsilon - (1 + C_r)}{(1 + C_r^2)^{1/2}} = \frac{2/0.75 - (1 + 0.5)}{(1 + 0.5^2)^{1/2}} = 1.04$$

$$NTU = -(1 + C_r^2) \ln\left(\frac{E - 1}{E + 1}\right) = 3.44$$

Therefore,

$$UA = NTU \times C_{\min} = 3.44 \times 836.8 \text{ W/K} = 2881 \text{ W/K} \quad (3)$$

and

$$h_o = (0.024\text{m})^{-1} \left[ (2881 \text{ W/K})^{-1} \times 20 \times \pi \times 3\text{m} - 1/3594 \text{ W/m}^2 \cdot \text{K} \times 0.020\text{m} \right]^{-1}$$
$$= 808 \text{ W/m}^2 \cdot \text{K} \quad <$$

### PROBLEM 11.59

**KNOWN:** Engine oil cooled by air in a cross-flow heat exchanger with both fluids unmixed.

**FIND:** (a) Heat transfer coefficient on oil side of exchanger assuming fully-developed conditions and constant wall heat flux, (b) Effectiveness, and (c) Outlet temperature of the oil.

**SCHEMATIC:**

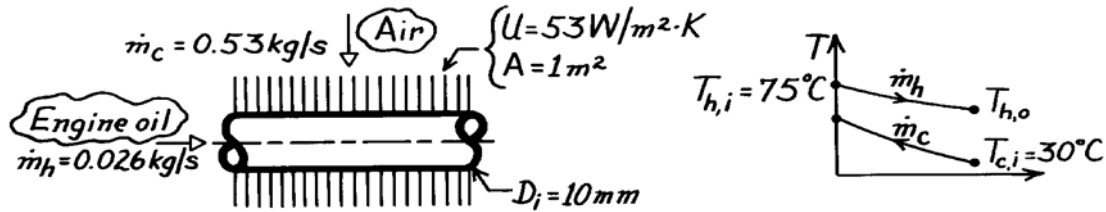

**ASSUMPTIONS:** (1) Negligible heat loss to surroundings, (2) Constant properties, (3) Oil flow and thermal conditions are fully developed, (4) Oil cooling process approximates constant wall flux conditions.

**PROPERTIES:** Table A-5, Engine oil (assume  $T_{h,o} \approx 45^\circ\text{C}$ ,  $\bar{T}_h = (45 + 75)^\circ\text{C}/2 = 333\text{ K}$ ):  $c_h = 2047\text{ J/kg}\cdot\text{K}$ ,  $\mu = 7.45 \times 10^{-2}\text{ N}\cdot\text{s/m}^2$ ,  $k = 0.140\text{ W/m}\cdot\text{K}$ ; Table A-4, Air (assume  $T_{c,o} \approx 40^\circ\text{C}$ ,  $\bar{T}_c = (30 + 40)^\circ\text{C}/2 = 308\text{ K}$ , 1 atm):  $c_c = 1007\text{ J/kg}\cdot\text{K}$ .

**ANALYSIS:** (a) For the oil side, using Eq. 8.6, find,

$$\text{Re}_D = 4 \dot{m} / \pi D \mu = 4(0.026\text{ kg/s}) / (\pi(0.01\text{m})7.45 \times 10^{-2}\text{ N}\cdot\text{s/m}^2) = 44.4$$

Since  $\text{Re}_D < 2000$  the flow is laminar. For the fully-developed conditions with constant wall flux,

$$\text{Nu}_D = \frac{h_i D}{k} = 4.36, \quad h_i = 4.36 \frac{k}{D} = 4.36 \frac{0.140\text{ W/m}\cdot\text{K}}{0.01\text{m}} = 61.0\text{ W/m}^2\cdot\text{K}. \quad <$$

(b) The effectiveness can be determined by the  $\epsilon$ -NTU method.

$$C_h = \dot{m}_h c_h = 0.026\text{ kg/s} \times 2047\text{ J/kg}\cdot\text{K} = 53.22\text{ W/K} \quad C_{\min} = C_h$$

$$C_c = \dot{m}_c c_c = 0.53\text{ kg/s} \times 1007\text{ J/kg}\cdot\text{K} = 533.7\text{ W/K} \quad C_{\min}/C_{\max} = 0.10$$

$$\text{NTU} = UA/C_{\min} = 53\text{ W/m}^2\cdot\text{K} \times 1\text{m}^2 / 53.22\text{ W/K} = 1.00.$$

Using Fig. 11.14, with  $C_{\min}/C_{\max} = 0.1$  and  $\text{NTU} = 1$ , find  $\epsilon \approx 0.64$ . <

(c) From Eqs. 11.19 and 11.18,

$$\epsilon = \frac{q}{q_{\max}} = \frac{C_h (T_{h,i} - T_{h,o})}{C_{\min} (T_{h,i} - T_{c,i})} = \frac{T_{h,i} - T_{h,o}}{T_{h,i} - T_{c,i}}.$$

Solving for  $T_{h,o}$  and substituting numerical values, find

$$T_{h,o} = T_{h,i} - \epsilon (T_{h,i} - T_{c,i}) = 75^\circ\text{C} - 0.64(75 - 30)^\circ\text{C} = 46.2^\circ\text{C}. \quad <$$

**COMMENTS:** Note that the  $\bar{T}_h$  value at which the oil properties were evaluated is reasonable.

## PROBLEM 11.60

**KNOWN:** Dimensions, configuration and material of a single-pass, cross-flow heat exchanger. Inlet conditions of inner and outer flow. Fouling factor of inner surface.

**FIND:** (a) Percent fuel savings for prescribed conditions, (b) Effect of UA on air outlet temperature and fuel savings.

**SCHEMATIC:**

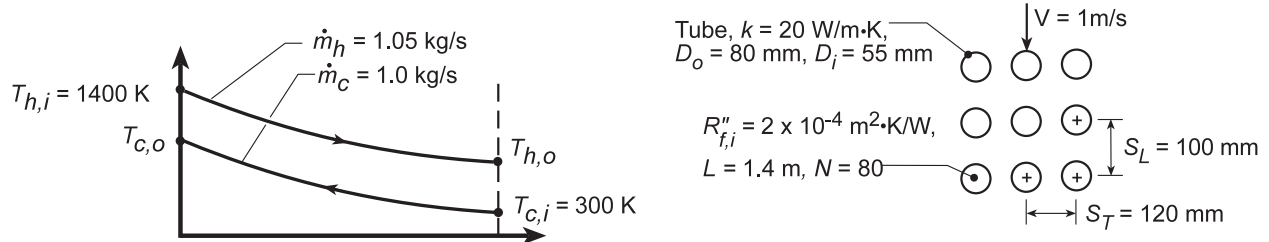

**ASSUMPTIONS:** (1) Negligible heat loss to surroundings, (2) Air properties are those of atmospheric air at 300 K, (3) Gas properties are those of atmospheric air at 1400 K, (4) Tube wall temperature may be approximated as 800 K for treating variable property effects.

**PROPERTIES:** Table A.4, Air (1 atm, T = 300 K):  $\nu = 15.89 \times 10^{-6} \text{ m}^2/\text{s}$ ,  $c_p = 1007 \text{ J/kg}\cdot\text{K}$ ,  $k = 0.0263 \text{ W/m}\cdot\text{K}$ ,  $\text{Pr} = 0.707$ ; (T = 1400 K):  $\mu = 530 \times 10^{-7} \text{ kg/s}\cdot\text{m}$ ,  $c_p = 1207 \text{ J/kg}\cdot\text{K}$ ,  $k = 0.091 \text{ W/m}\cdot\text{K}$ ,  $\text{Pr} = 0.703$ ; (T = 800 K):  $\text{Pr} = 0.709$ .

**ANALYSIS:** (a) With capacity rates of  $C_c = \dot{m}_c c_{p,c} = 1 \text{ kg/s} \times 1007 \text{ J/kg}\cdot\text{K} = 1007 \text{ W/K} = C_{\min}$  and  $C_h = \dot{m}_h c_{p,h} = 1.05 \text{ kg/s} \times 1207 \text{ J/kg}\cdot\text{K} = 1267 \text{ W/K} = C_{\max}$ ,  $C_{\min}/C_{\max} = 0.795$ . The overall coefficient is

$$\frac{1}{UA} = \frac{1}{h_i A_i} + \frac{R''_{f,i}}{A_i} + \frac{\ln(D_o/D_i)}{(2\pi kL)N} + \frac{1}{h_o A_o}$$

For flow through a single tube,

$$\text{Re}_D = \frac{4\dot{m}_h}{N\pi D_i \mu} = \frac{4 \times 1.05 \text{ kg/s}}{80\pi (0.055 \text{ m}) 530 \times 10^{-7} \text{ kg/s}\cdot\text{m}} = 5733$$

Assuming fully developed turbulent flow throughout and using the Gnielinski correlation,

$$\text{Nu}_D = \frac{(f/8)(\text{Re}_D - 1000)\text{Pr}}{1 + 12.7(f/8)^{1/2}(\text{Pr}^{2/3} - 1)} = 18.8$$

where  $f = (0.79 \ln \text{Re}_D - 1.64)^{-2} = 0.0370$

$$h_i = \text{Nu}_D k / D_i = 18.8 (0.091 \text{ W/m}\cdot\text{K}) / 0.055 \text{ m} = 31.1 \text{ W/m}^2\cdot\text{K}$$

For flow over the tube bank,

$$V_{\max} = [S_T / (S_T - D_o)] V = [0.12 \text{ m} / (0.12 - 0.08) \text{ m}] 1 \text{ m/s} = 3 \text{ m/s}$$

$$\text{Re}_{D,\max} = \frac{V_{\max} D_o}{\nu} = \frac{3 \text{ m/s} (0.08 \text{ m})}{15.89 \times 10^{-6} \text{ m}^2/\text{s}} = 15,100$$

From the Zukauskas correlation for a tube bank,

$$\overline{\text{Nu}}_D = 0.27 (15,100)^{0.63} (0.707)^{0.36} (0.707/0.709)^{1/4} = 102.3$$

$$\overline{h}_o = \overline{\text{Nu}}_D (k/D_o) = 102.3 (0.0263 \text{ W/m}\cdot\text{K}) / 0.08 \text{ m} = 33.6 \text{ W/m}^2\cdot\text{K}$$

Hence, based on the inner surface, the overall coefficient is

Continued...

**PROBLEM 11.60 (Cont.)**

$$\frac{1}{U_i} = \frac{1}{h_i} + R_{f,i}'' + \frac{D_i \ln(D_o/D_i)}{2k} + \frac{D_i}{D_o h_o}$$

$$\frac{1}{U_i} = \left( 0.0322 + 0.0002 + \frac{0.055 \ln(0.08/0.055)}{20} + \frac{0.055}{0.08 \times 33.6} \right) \text{m}^2 \cdot \text{K/W}$$

$$U_i = \left[ 0.0322 + 0.0002 + 0.001 + 0.0205 \text{m}^2 \cdot \text{K/W} \right]^{-1} = 18.6 \text{ W/m}^2 \cdot \text{K}$$

Hence,  $(UA)_i = U_i N \pi D_i L = 18.6 \text{ W/m}^2 \cdot \text{K} \times 80 \pi (0.055 \text{ m}) 1.4 \text{ m} = 360 \text{ W/K}$ . The number of transfer units is then  $NTU = UA/C_{\min} = 360 \text{ W/K}/1007 \text{ W/K} = 0.357$ , and with  $C_{\text{mixed}}/C_{\text{unmixed}} = C_c/C_h = C_{\min}/C_{\max} = 0.795$ , Fig. 11.15 yields  $\varepsilon \approx 0.29$  or, from Eq. 11.34 a,

$$\varepsilon = 1 - \exp\left(-C_r^{-1} \{1 - \exp[-C_r \cdot NTU]\}\right) = 0.267.$$

Hence, with

$$q_{\max} = C_{\min} (T_{h,i} - T_{c,i}) = 1007 \text{ W/K} (1100 \text{ K}) = 1.11 \times 10^6 \text{ W}$$

$$q = \varepsilon q_{\max} = 0.267 \times 1.11 \times 10^6 \text{ W} = 295,800 \text{ W}$$

$$T_{c,o} = T_{c,i} + q/C_{\min} = 300 \text{ K} + (295,800 \text{ W}/1007 \text{ W/K}) = 594 \text{ K}.$$

Hence,

$$\% \text{ fuel savings} \equiv FS = (\Delta T_c / 10 \text{ K}) \times 1\% = (294 \text{ K}/10 \text{ K}) \times 1\% = 29.4\%$$

(b) Using the Heat Exchangers Toolpad of IHT to perform the parametric calculations, the following results are obtained.

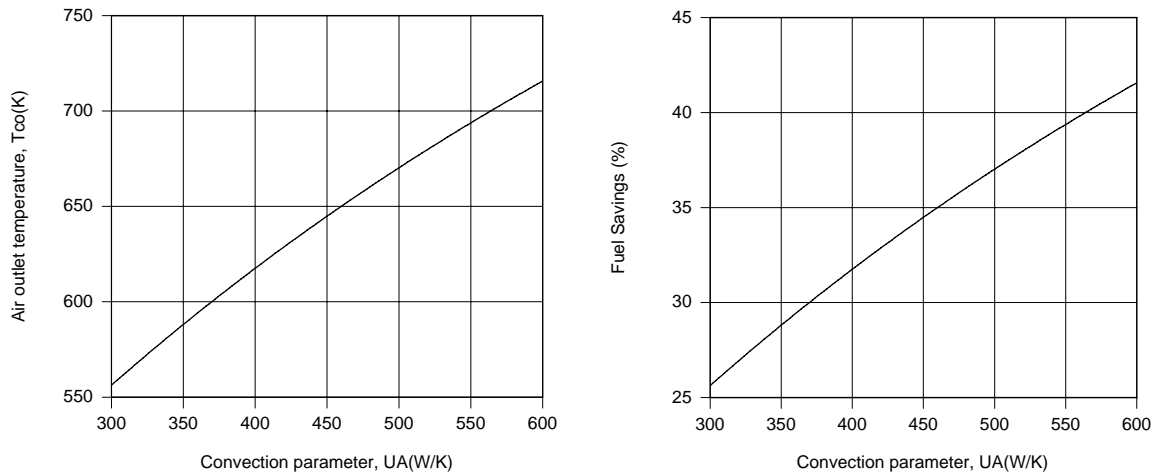

Significant benefits are derived by increasing UA, with values of  $T_{c,o} = 716 \text{ K}$  and  $FS = 41.6\%$  obtained for  $UA = 600 \text{ W/K}$ . The major contributions to the total resistance are made by the inner and outer convection resistances. These contributions could be reduced by using extended surfaces on both the inner and outer surfaces.

**COMMENTS:** For part (a), properties of the flue gas should be evaluated at  $(T_{h,i} + T_{h,o})/2$  and the calculations repeated.

## PROBLEM 11.61

**KNOWN:** Rate of thermal energy production in combustor and transfer to load in furnace. Cold air and flue gas flowrates and specific heats in recuperator. Recuperator cold air inlet temperature.

**FIND:** Recuperator hot gas inlet and outlet temperatures and air outlet temperature for a recuperator effectiveness of  $\varepsilon = 0.3$ . Value of  $\varepsilon$  needed to achieve a recuperator outlet temperature of 800 K.

**SCHEMATIC:**

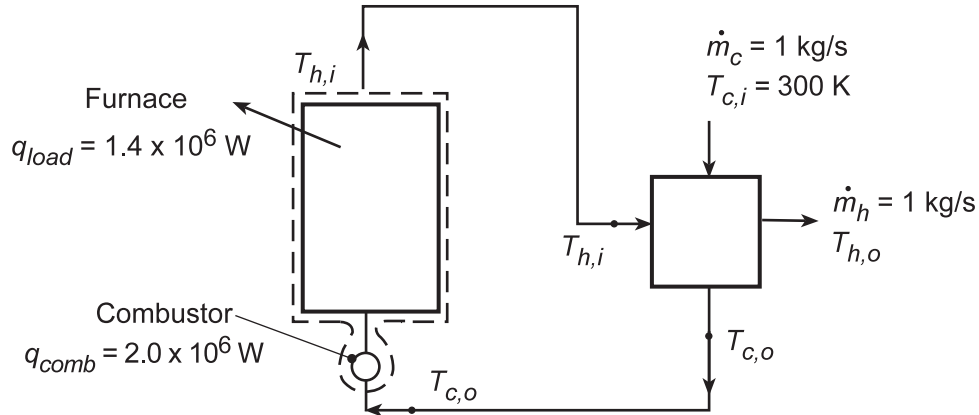

**ASSUMPTIONS:** (1) Constant properties, (2) Negligible effect of fuel addition on flow rate.

**PROPERTIES:** Air and gas:  $c_{p,c} = c_{p,h} = 1200 \text{ J/kg}\cdot\text{K}$ .

**ANALYSIS:** With  $C_c = C_h = C_{\min}$ , the effectiveness of the recuperator,  $\varepsilon = q/q_{\max}$ , may be expressed as

$$\varepsilon = \frac{C_c (T_{c,o} - T_{c,i})}{C_{\min} (T_{h,i} - T_{c,i})} = \frac{T_{c,o} - 300 \text{ K}}{T_{h,i} - 300 \text{ K}} = 0.3$$

The unknown temperatures,  $T_{c,o}$  and  $T_{h,i}$ , are also related through an energy balance performed on the air entering the combustor and leaving the furnace. Specifically,

$$C(T_{h,i} - T_{c,o}) = q_{\text{comb}} - q_{\text{load}} = 0.6 \times 10^6 \text{ W}$$

where  $C = 1 \text{ kg/s} \times 1200 \text{ J/kg}\cdot\text{K} = 1200 \text{ W/K}$ . Solving the foregoing equations, we obtain

$$T_{h,i} = 1014 \text{ K} \quad T_{c,o} = 514 \text{ K} \quad \leftarrow$$

Expressing the effectiveness as

$$\varepsilon = \frac{C_h (T_{h,i} - T_{h,o})}{C_{\min} (T_{h,i} - T_{c,i})} = \frac{1014 \text{ K} - T_{h,o}}{714 \text{ K}}$$

we also obtain  $T_{h,o} = 800 \text{ K}$ . ←

For a combustor air inlet temperature of  $T_{c,o} = 800 \text{ K}$  and  $T_{h,i} = 1014 \text{ K}$ , the required effectiveness is

$$\varepsilon = \frac{T_{c,o} - T_{c,i}}{T_{h,i} - T_{c,i}} = \frac{(800 - 300) \text{ K}}{(1014 - 300) \text{ K}} = 0.70 \quad \leftarrow$$

**COMMENTS:** The effectiveness of the recuperator may be increased by increasing NTU and hence UA, as, for example, by increasing the number of tubes.

## PROBLEM 11.62

**KNOWN:** Shell-tube heat exchanger with one shell and single tube pass; Tube side: exhaust gas with specified flow rate and temperature change; Shell side: supply of saturated water at 11.7 bar; Tube dimensions and thermal conductivity, and fouling resistance on gas side,  $R''_{f,h}$ , specified.

**FIND:** Number of tubes and their length if the gas velocity is not to exceed  $u_{m,i} = 25$  m/s.

**SCHEMATIC:**

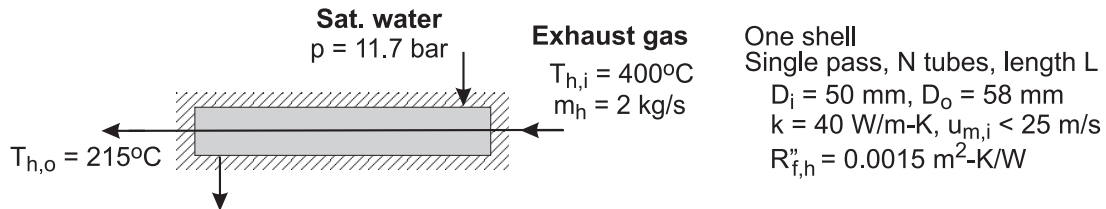

**ASSUMPTIONS:** (1) Steady-state conditions, (2) Negligible losses to the surroundings, (3) Negligible water-side thermal resistance, (4) Exhaust gas properties are those of atmospheric air, (5) Gas-side flow is fully developed, and (6) Constant properties.

**PROPERTIES:** Table A-4, Air ( $\bar{T}_h = 581$  K):  $\rho = 0.600$  kg/m<sup>3</sup>,  $c = 1047$  J/kg·K,  $\nu = 4.991 \times 10^{-5}$  m<sup>2</sup>/s,  $k = 0.0457$  W/m·K,  $Pr = 0.684$ . Table A-6, Water (11.7 bar, saturated):  $T_{c,i} = 460$  K = 187°C.

**ANALYSIS:** We'll employ the NTU- $\epsilon$  method to design the exchanger. Since  $C_r = 0$ , use Eq. 11.35b.

$$NTU = -\ln(1 - \epsilon)$$

where the effectiveness can be evaluated from Eqs. 11.18 and 11.19.

$$C_{\min} = C_h = \dot{m}_h c_h = 2 \text{ kg/s} \times 1047 \text{ J/kg} \cdot \text{K} = 2094 \text{ W/K}$$

$$\epsilon = \frac{C_h (T_{h,i} - T_{h,o})}{C_{\min} (T_{h,i} - T_{c,i})} = \frac{(400 - 215)^\circ\text{C}}{(400 - 187)^\circ\text{C}} = 0.868$$

$$NTU = -\ln(1 - 0.868) = 2.029$$

From Eq. 11.24,

$$UA = C_{\min} \cdot NTU = 2094 \text{ W/K} \times 2.029 = 4249 \text{ W/K} \quad (1)$$

Considering the gas-side flow rate and velocity criteria, find the number of tubes required as

$$\dot{m}_h = N \cdot \rho_h \cdot A_c \cdot u_{m,i} = N \cdot \rho_h \left( \pi D_1^2 / 4 \right) u_{m,i}$$

Continued ...

### PROBLEM 11.62 (Cont.)

$$2 \text{ kg/s} = N \times 0.600 \text{ kg/m}^3 \times \pi (0.050 \text{ m})^2 / 4 \times 25 \text{ m/s}$$

$$N = 67.9 \text{ tubes, specify 68}$$

&lt;

The overall coefficient, considering the convection process, fouling resistance and the tube thermal resistance, is evaluated as

$$U_i = 1 / [R_{f,i}'' + R_{cv,i}'' + R_{cd,t}''] = 56.4 \text{ W/m}^2 \cdot \text{K}$$

$$R_{f,i}'' = 0.0015 \text{ m}^2 \cdot \text{K/W}$$

$$R_{cv,i}'' = 1/h_i = 1/62 \text{ W/m}^2 \cdot \text{K} = 0.0161 \text{ m}^2 \cdot \text{K/W}$$

$$R_{cd,t}'' = \frac{D_i \ln(D_o/D_i)}{2k} = \frac{0.050 \text{ m} \ln(58/50)}{2 \times 40 \text{ W/m} \cdot \text{K}} = 9.28 \times 10^{-5} \text{ m}^2 \cdot \text{K/W}$$

where the gas-side convection coefficient estimate is explained in the Comments section. Substituting numerical values, determine the required tube length

$$[UA] = U_i \cdot A_i = U_i (N \pi D_i L)$$

$$4249 \text{ W/K} = 56.4 \text{ W/m}^2 \cdot \text{K} \times 68 \times \pi \times 0.050 \text{ m} \times L$$

$$L = 7.1 \text{ m}$$

&lt;

**COMMENTS:** (1) Is the assumption of negligible water-side thermal resistance reasonable? Explain why.

(2) Knowing the tube gas-side velocity, the usual convection correlation calculation methodology is followed. The flow is turbulent,  $Re_{D_i} = 2.5 \times 10^4$ , and assuming fully developed flow, use the Dittius-Boelter correlation, Eq. 8.60, to find  $Nu_{D_i} = 67.8$  and  $h_i = 62.0 \text{ W/m}^2 \cdot \text{K}$ .

### PROBLEM 11.63

**KNOWN:** Hot and cold gas flow rates and inlet temperatures of a recuperator. Overall heat transfer coefficient. Desired cold gas outlet temperature.

**FIND:** (a) Required surface area, (b) Effect of surface area on cold-gas outlet temperature.

**SCHEMATIC:**

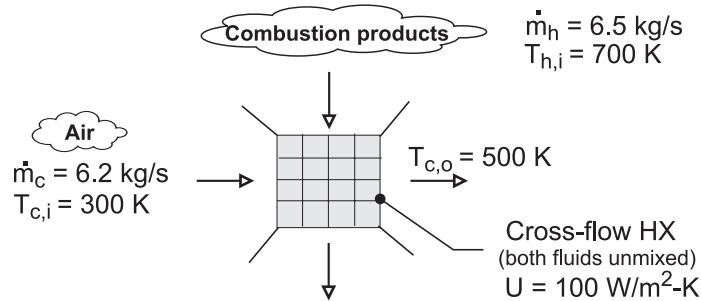

**ASSUMPTIONS:** (1) Negligible heat loss to surroundings, (2) Constant properties.

**PROPERTIES:** Given:  $c_{p,c} = c_{p,h} = 1040 \text{ W/m}\cdot\text{K}$ .

**ANALYSIS:** (a) With  $C_{\min} = C_c = 6.2 \text{ kg/s} \times 1040 \text{ J/kg}\cdot\text{K} = 6,448 \text{ W/K}$ ,  $C_{\max} = C_h = 6.5 \text{ kg/s} \times 1040 \text{ J/kg}\cdot\text{K} = 6,760 \text{ W/K}$ ,  $C_r = C_{\min}/C_{\max} = 0.954$ ,  $q = C_c (T_{c,o} - T_{c,i}) = 6,448 \text{ W/K} (200 \text{ K}) = 1.29 \times 10^6 \text{ W}$ ,  $q_{\max} = C_{\min} (T_{h,i} - T_{c,i}) = 6,448 \text{ W/K} (400 \text{ K}) = 2.58 \times 10^6 \text{ W}$ , and  $\epsilon = q/q_{\max} = 0.50$ , Fig. 11.14 yields  $\text{NTU} \approx 1.10$ . Hence

$$A = \frac{\text{NTU} \times C_{\min}}{U} = \frac{1.10 \times 6,448 \text{ W/K}}{100 \text{ W/m}^2 \cdot \text{K}} = 70.9 \text{ m}^2 \quad <$$

(b) Using the Heat Exchanger option of *IHT*, the following result was obtained

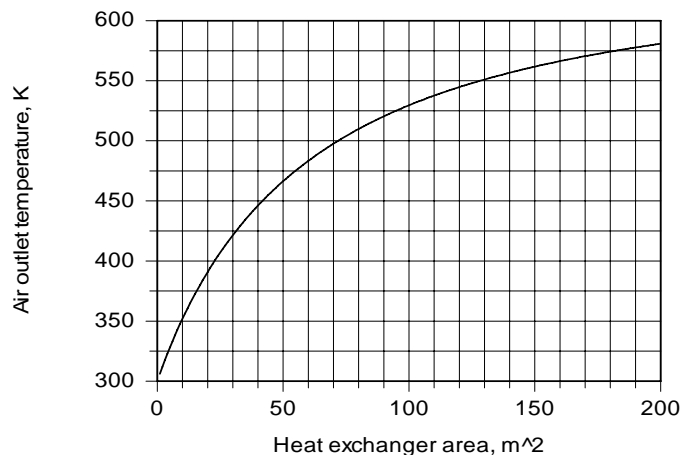

The air outlet temperature increases, of course, with increasing heat exchanger area, but the approach to the maximum possible outlet temperature,  $T_{h,i}$ , is slow and the heat exchanger size needed to achieve a large outlet temperature may be prohibitively expensive.



### PROBLEM 11.64

**KNOWN:** Inlet temperature and flow rates for a concentric tube heat exchanger. Hot fluid outlet temperature.

**FIND:** (a) Maximum possible heat transfer rate and effectiveness, (b) Preferred mode of operation.

**SCHEMATIC:**

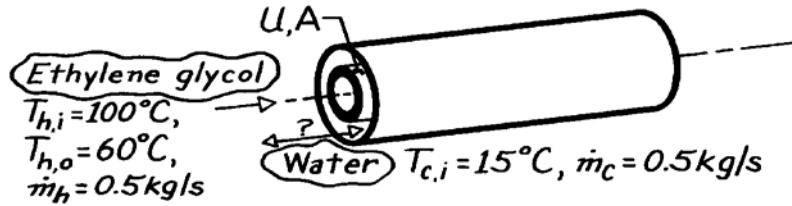

**ASSUMPTIONS:** (1) Steady-state operation, (2) Negligible heat loss to surroundings, (3) Fixed overall heat transfer coefficient.

**PROPERTIES:** Table A-5, Ethylene glycol ( $\bar{T}_m = 80^\circ\text{C}$ ):  $c_p = 2650 \text{ J/kg}\cdot\text{K}$ ; Table A-6, Water ( $\bar{T}_m \approx 30^\circ\text{C}$ ):  $c_p = 4178 \text{ J/kg}\cdot\text{K}$ .

**ANALYSIS:** (a) Using the  $\epsilon$ -NTU method, find

$$C_{\min} = C_h = \dot{m}_h c_{p,h} = (0.5 \text{ kg/s})(2650 \text{ J/kg}\cdot\text{K}) = 1325 \text{ W/K}.$$

Hence from Eqs. 11.18 and 11.6,

$$q_{\max} = C_{\min} (T_{h,i} - T_{c,i}) = (1325 \text{ W/K})(100 - 15)^\circ\text{C} = 1.13 \times 10^5 \text{ W}.$$

$$q = \dot{m}_h c_{p,h} (T_{h,i} - T_{h,o}) = 0.5 \text{ kg/s} (2650 \text{ J/kg}\cdot\text{K})(100 - 60)^\circ\text{C} = 0.53 \times 10^5 \text{ W}. <$$

Hence from Eq. 11.19,

$$\epsilon = q/q_{\max} = 0.53 \times 10^5 / 1.13 \times 10^5 = 0.47. <$$

(b) From Eq. 11.7,

$$T_{c,o} = T_{c,i} + \frac{q}{\dot{m}_c c_{p,c}} = 15^\circ\text{C} + \frac{0.53 \times 10^5}{0.5 \text{ kg/s} \times 4178 \text{ J/kg}\cdot\text{K}} = 40.4^\circ\text{C}.$$

Since  $T_{c,o} < T_{h,o}$ , a *parallel flow* mode of operation is possible. However, with  $(C_{\min}/C_{\max}) = (\dot{m}_h c_{p,h}/\dot{m}_c c_{p,c}) = 0.63$ ,

$$\text{Fig. 11.10} \rightarrow (\text{NTU})_{\text{PF}} \approx 0.95$$

$$\text{Fig. 11.11} \rightarrow (\text{NTU})_{\text{CF}} \approx 0.75.$$

Hence from Eq. 11.24

$$(A_{\text{CF}}/A_{\text{PF}}) = (\text{NTU})_{\text{CF}}/(\text{NTU})_{\text{PF}} \approx (0.75/0.95) = 0.79.$$

Because of the reduced size requirement, and hence capital investment, the *counterflow* mode of operation is preferred.

### PROBLEM 11.65

**KNOWN:** Single-pass, cross-flow heat exchanger with both fluids (water) unmixed; hot water enters at  $90^\circ\text{C}$  and at  $10,000\text{ kg/h}$  while cold water enters at  $10^\circ\text{C}$  and at  $20,000\text{ kg/h}$ ; effectiveness is  $60\%$ .

**FIND:** Cold water exit temperature,  $T_{c,o}$ .

**SCHEMATIC:**

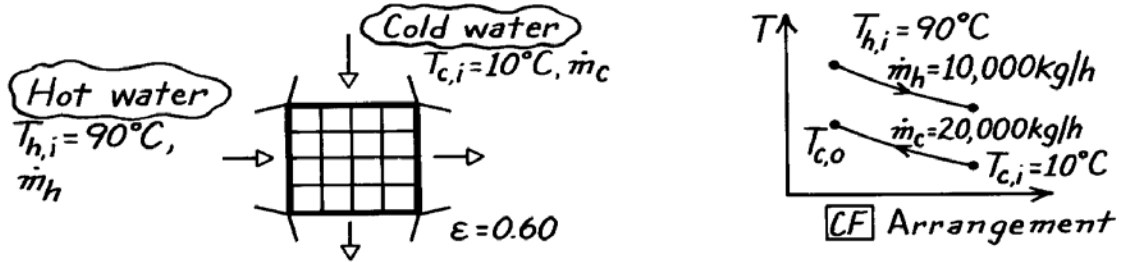

**ASSUMPTIONS:** (1) Negligible heat loss to surroundings, (2) Constant properties.

**PROPERTIES:** Table A-6, Water ( $\bar{T}_c \approx (10 + 40)^\circ\text{C}/2 \approx 300\text{ K}$ ):  $c_c = 4179\text{ J/kg}\cdot\text{K}$ ; Table A-6, Water ( $\bar{T}_h \approx (90 + 60)^\circ\text{C}/2 \approx 350\text{ K}$ ):  $c_h = 4195\text{ J/kg}\cdot\text{K}$ .

**ANALYSIS:** From an energy balance on the cold fluid, Eq. 11.7, the outlet temperature can be expressed as

$$T_{c,o} = T_{c,i} + q / \dot{m}_c C_c.$$

The heat rate can be written in terms of the effectiveness and  $q_{\max}$ . Using Eqs. 11.19 and 11.18,

$$q = \varepsilon q_{\max} = \varepsilon C_{\min} (T_{h,i} - T_{c,i}).$$

By inspection, it can be noted that the hot fluid is the minimum capacity fluid. Substituting numerical values,

$$q = \varepsilon (\dot{m}_h c_h) (T_{h,i} - T_{c,i})$$

$$q = 0.60(10,000\text{ kg/h} / 3600\text{ s/h}) 4195\text{ J/kg}\cdot\text{K} (90 - 10)^\circ\text{C} = 559.3 \times 10^3\text{ W}.$$

The exit temperature of the cold water is then

$$T_{c,o} = 10^\circ\text{C} + 559.3 \times 10^3\text{ W} / \frac{20,000}{3600}\text{ kg/s} \times 4179\text{ J/kg}\cdot\text{K} = 34.1^\circ\text{C}. \quad <$$

**COMMENTS:** (1) The properties of the cold fluid should be evaluated at  $\bar{T} = (T_{c,o} + T_{c,i})/2 = (34.1 + 10)^\circ\text{C}/2 = 295\text{ K}$ . Note the analysis assumed  $\bar{T}_c \approx 300\text{ K}$ , hence little error is incurred. For best precision, one should check  $\bar{T}_h$  and  $C_h$ .

(2) From Fig. 11.14, the value of NTU could be determined. First evaluate the term

$$C_{\min} / C_{\max} = \dot{m}_h C_h / \dot{m}_c C_c = \frac{10,000 \times 4195}{20,000 \times 4179} = 0.50$$

and with  $\varepsilon = 0.60$ , find  $\text{NTU} \approx 1.2$ .

### PROBLEM 11.66

**KNOWN:** Hxer consisting of 32 tubes in 0.6m square duct. Hot water enters tubes at 150°C with mean velocity 0.5 m/s. Atmospheric air at 10°C enters exchanger with volumetric flow rate of 1 m<sup>3</sup>/s. Heat transfer coefficient on tube outer surfaces is 400 W/m<sup>2</sup>·K.

**FIND:** Outlet temperatures of the fluids, T<sub>c,o</sub> and T<sub>h,o</sub>.

**SCHEMATIC:**

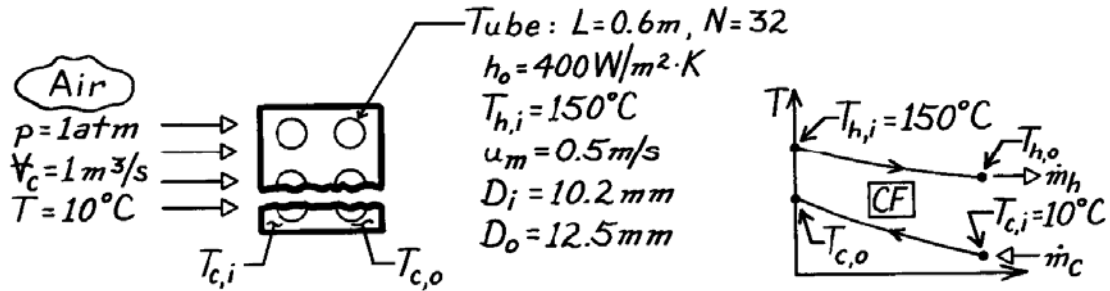

**ASSUMPTIONS:** (1) Negligible heat loss to surroundings, (2) Constant properties, (3) Hxer is a single-pass, cross-flow type with one fluid mixed (air) and the other unmixed (water), (4) Tube water flow is fully developed, (5) Negligible thermal resistance due to tube wall.

**PROPERTIES:** Table A-4, Air (T<sub>c,i</sub> = 10°C = 283 K, 1 atm): ρ = 1.2407 kg/m<sup>3</sup>; Table A-4, Air (assume T<sub>c,o</sub> ≈ 40°C, T̄<sub>c</sub> = (10 + 40)°C/2 = 298 K, 1 atm): c<sub>p</sub> = 1007 J/kg·K; Table A-6, Water (assume T<sub>h,o</sub> ≈ 140°C, T̄<sub>h</sub> = (140 + 150)°C/2 = 418 K): ρ = 1/v<sub>f</sub> = 1/1.0850 × 10<sup>-3</sup> m<sup>3</sup>/kg, c<sub>p</sub> = 4297 J/kg·K, μ<sub>f</sub> = 188 × 10<sup>-6</sup> N·s/m<sup>2</sup>, k<sub>f</sub> = 0.688 W/m·K, Pr<sub>f</sub> = 1.18.

**ANALYSIS:** Using the ε-NTU method, first find the capacity rates.

$$C_h = \dot{m}_h c_{p,h} = (\rho A_c u_m)_h N \cdot c_{p,h}$$

$$C_h = \frac{1}{1.0850 \times 10^{-3} \text{ m}^3/\text{kg}} \times \frac{\pi}{4} \left(10.2 \times 10^{-3} \text{ m}\right)^2 \times 0.5 \frac{\text{m}}{\text{s}} \times 32 \times 4297 \frac{\text{J}}{\text{kg} \cdot \text{K}} = 5178 \frac{\text{W}}{\text{K}}$$

$$C_c = \dot{m}_c c_{p,c} = (\rho V)_c c_{p,c} = 1.2407 \frac{\text{kg}}{\text{m}^3} \times 1 \text{ m}^3/\text{s} \times 1007 \text{ J/kg} \cdot \text{K} = 1249 \frac{\text{W}}{\text{K}}. \quad (1,2)$$

Note that the cold fluid is the minimum fluid, C<sub>c</sub> = C<sub>min</sub>. The overall heat transfer coefficient follows from Eq. 11.5,

$$U_o A_o = \left[ \frac{1}{h_i A_i} + \frac{1}{h_o A_o} \right]^{-1} \quad (3)$$

where h<sub>i</sub> must be estimated from an appropriate internal flow correlation. The Reynolds number for water flow is

$$\text{Re}_D = \frac{\rho u_m D_i}{\mu} = \frac{\left(1/1.0850 \times 10^{-3} \text{ m}^3/\text{kg}\right) \times 0.5 \text{ m/s} \times \left(10.2 \times 10^{-3} \text{ m}\right)}{188 \times 10^{-6} \text{ N} \cdot \text{s}/\text{m}^2} = 25,002. \quad (4)$$

Continued ...

### PROBLEM 11.66 (Cont.)

The flow is turbulent and since  $L/D_i = 0.6\text{m}/10.2 \times 10^{-3}\text{m} = 59$ , fully developed conditions may be assumed. The Dittus-Boelter correlation with  $n = 0.3$  is appropriate.

$$\text{Nu}_D = \frac{h_i D_i}{k} = 0.023 \text{Re}_D^{0.8} \text{Pr}^{0.3} = 0.023(25,002)^{0.8} (1.18)^{0.3} = 79.7$$

$$h_i = \frac{k}{D_i} \text{Nu}_D = \frac{0.688 \text{W/m}\cdot\text{K}}{10.2 \times 10^{-3}\text{m}} \times 79.7 = 5376 \text{W/m}^2 \cdot \text{K}.$$

Substituting numerical values into Eq. (3), find

$$U_o = \left[ \left( \frac{12.5\text{mm}}{10.2\text{mm}} \right) \frac{1}{5376 \text{W/m}^2 \cdot \text{K}} + \frac{1}{400 \text{W/m}^2 \cdot \text{K}} \right]^{-1} = 366.6 \text{W/m}^2 \cdot \text{K}.$$

It follows from Eq. 11.24, with  $A_o = N(\pi D_o L)$ , that

$$\text{NTU} = \frac{U_o A_o}{C_{\min}} = 366.6 \frac{\text{W}}{\text{m}^2 \cdot \text{K}} \times \left( 32 \times \pi \times 12.5 \times 10^{-3}\text{m} \times 0.6\text{m} \right) / 1249 \frac{\text{W}}{\text{K}} = 0.22.$$

From Fig. 11.15, noting that  $C_{\min} = C_c$  is the mixed fluid (solid curves),

$$\frac{C_{\text{mixed}}}{C_{\text{unmixed}}} = \frac{C_{\min}}{C_{\max}} = \frac{C_c}{C_h} = \frac{1249 \text{W/K}}{5178 \text{W/K}} = 0.24$$

and with  $\text{NTU} = 0.22$  find  $\varepsilon \approx 0.19$ . From the definition of effectiveness, Eq. 11.19,

$$\varepsilon = \frac{q}{q_{\max}} = \frac{C_c (T_{c,o} - T_{c,i})}{C_{\min} (T_{h,i} - T_{c,i})}$$

$$T_{c,o} = T_{c,i} + \varepsilon (T_{h,i} - T_{c,i}) = 10^\circ\text{C} + 0.19(150 - 10)^\circ\text{C} = 36.6^\circ\text{C}. \quad <$$

Equating the energy balances on both fluids,

$$C_c (T_{c,o} - T_{c,i}) = C_h (T_{h,i} - T_{h,o})$$

or

$$T_{h,o} = T_{h,i} - \frac{C_c}{C_h} (T_{c,o} - T_{c,i})$$

$$T_{h,o} = 150^\circ\text{C} - \frac{1249 \text{W/K}}{5178 \text{W/K}} (36.6 - 10)^\circ\text{C} = 143.5^\circ\text{C}. \quad <$$

**COMMENTS:** (1) Note that the assumptions of  $T_{h,o}$  and  $T_{c,o}$  used in evaluating properties are reasonable.

(2) Note that to calculate  $\dot{m}_c$  from  $V$ , the density at  $10^\circ\text{C}$  is more appropriate than at  $\bar{T}_c$ .

### PROBLEM 11.67

**KNOWN:** Flow rates and inlet temperatures of exhaust gases and combustion air used in a cross-flow (one fluid mixed) heat exchanger. Overall heat transfer coefficient. Desired air outlet temperature.

**FIND:** Required heat exchanger surface area.

**SCHEMATIC:**

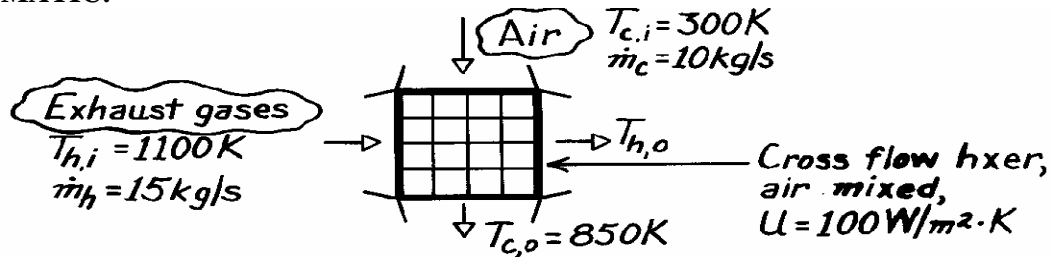

**ASSUMPTIONS:** (1) Steady-state conditions, (2) Negligible heat loss to surroundings, (3) Constant properties, (4) Gas properties are those of air.

**PROPERTIES:** Table A-4, Air ( $\bar{T}_m \approx 700\text{ K}$ , 1 atm):  $c_p = 1075\text{ J/kg}\cdot\text{K}$ .

**ANALYSIS:** Using the  $\epsilon - \text{NTU}$  method,

$$C_c = \dot{m}_c c_{p,c} = 10\text{ kg/s} \times 1075\text{ J/kg}\cdot\text{K} = 10,750\text{ W/K}$$

$$C_h = \dot{m}_h c_{p,h} = 15\text{ kg/s} \times 1075\text{ J/kg}\cdot\text{K} = 16,125\text{ W/K}$$

$$\text{Thus } C_r = C_{\min}/C_{\max} = 0.667, \quad \epsilon = q/q_{\max} = (T_{c,o} - T_{c,i})/(T_{h,i} - T_{c,i}) = 0.688$$

From Eq. 11.34b,

$$\text{NTU} = -\frac{1}{C_r} \ln[C_r \ln(1 - \epsilon) + 1] = -\frac{1}{0.667} \ln[0.667 \ln(1 - 0.688) + 1] = 2.24$$

Therefore,

$$A = \text{NTU} \times C_{\min}/U = (2.24 \times 10,750\text{ W/K}) / (100\text{ W/m}^2\cdot\text{K}) = 241\text{ m}^2$$

<

## PROBLEM 11.68

**KNOWN:** Heat exchanger with  $C_r = 0$ .

**FIND:** Derivation of Equation 11.35a.

**ASSUMPTIONS:** (1) Negligible heat transfer between heat exchangers and surroundings, negligible heat transfer between two heat exchangers, (2) Constant properties.

**ANALYSIS:** For  $C_r = 0$ ,  $C_{\max} \rightarrow \infty$ . If the hot stream is associated with  $C_{\max}$ , then  $T_{h,i} = T_{h,o}$ . From Eq. 8.45 with  $T_{\infty} = T_{h,i}$  and  $T_{m,o} = T_{c,o}$ ,  $T_{m,i} = T_{c,i}$ ,

$$\frac{T_{h,i} - T_{c,o}}{T_{h,i} - T_{c,i}} = \exp\left(-\frac{UA}{\dot{m}c_p}\right) = \exp(-NTU) \quad (1)$$

where  $\dot{m}c_p = C_c = C_{\min}$  or

$$T_{c,o} = T_{h,i} - (T_{h,i} - T_{c,i})\exp(-NTU) \quad (2)$$

and

$$q = \dot{m}c_p (T_{m,o} - T_{m,i}) = C_{\min} (T_{c,o} - T_{c,i}) = C_{\min} [T_{h,i} - (T_{h,i} - T_{c,i})\exp(-NTU) - T_{c,i}] \quad (3)$$

From Eq. 11.22,

$$q = \varepsilon C_{\min} (T_{h,i} - T_{c,i}) \quad (4)$$

Equating Eqs. (3) and (4) yields

$$\varepsilon C_{\min} (T_{h,i} - T_{c,i}) = C_{\min} [T_{h,i} - (T_{h,i} - T_{c,i})\exp(-NTU) - T_{c,i}]$$

or

$$\varepsilon = 1 - \exp(-NTU) \quad <$$

**COMMENTS:** Eq. 11.35a may be used to solve a wide variety of problems, beyond those associated with two-fluid heat exchangers, involving constant surface temperature conditions.

## PROBLEM 11.69

**KNOWN:** Inlet and outlet temperatures of natural gas and seawater in an LNG vaporizer. LNG flow rate and properties of its liquid and vapor phases, as well as phase change temperature and latent heat of vaporization. Overall heat transfer coefficients for three sections of the vaporizer. Seawater properties.

**FIND:** Required vaporizer heat transfer area.

**SCHEMATIC:**

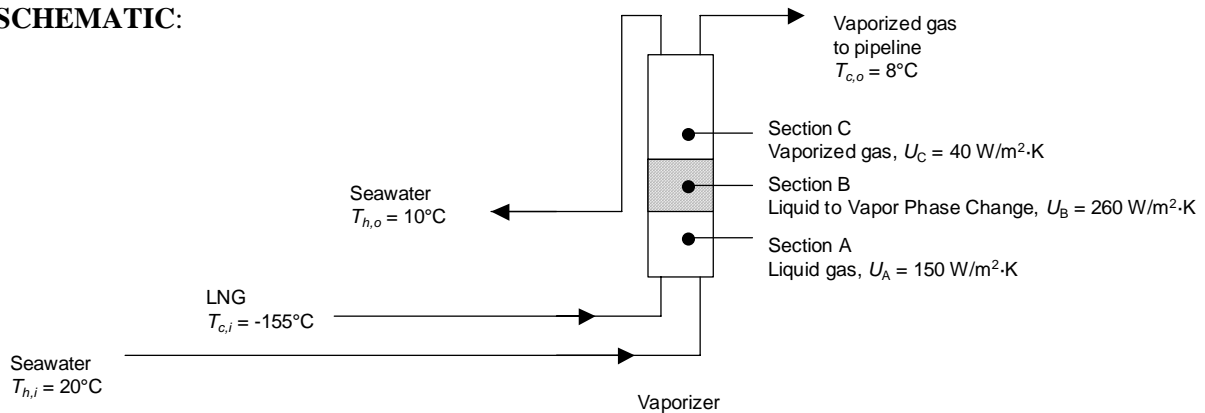

**ASSUMPTIONS:** (1) Negligible heat transfer between the heat exchanger and the surroundings, (2) Constant properties, (3) Parallel flow.

**PROPERTIES:** Given. NG:  $c_{p,l} = 4200 \text{ J/kg}\cdot\text{K}$ ,  $c_{p,v} = 2210 \text{ J/kg}\cdot\text{K}$ ,  $h_{fg} = 575 \text{ kJ/kg}$ ,  $T_f = -75^\circ\text{C}$ . SW:  $c_{p,sw} = 3985 \text{ J/kg}\cdot\text{K}$ .

**ANALYSIS:** Application of the conservation of energy principle to the gas stream yields

$$\begin{aligned}
 q &= \dot{m}_{\text{NG}} \left[ c_{p,l} (T_f - T_{c,i}) + h_{fg} + c_{p,v} (T_{c,o} - T_f) \right] = q_A + q_B + q_C \\
 &= 150 \text{ kg/s} \left[ 4200 \text{ J/kg}\cdot\text{K} (-75 - (-155)^\circ\text{C}) + 575 \times 10^3 \text{ J/kg}\cdot\text{K} + 2210 \text{ J/kg}\cdot\text{K} (8 - (-75)^\circ\text{C}) \right] \\
 &= 50.4 \times 10^6 \text{ W} + 86.3 \times 10^6 \text{ W} + 27.5 \times 10^6 \text{ W} = 164 \times 10^6 \text{ W} = 164 \text{ MW}
 \end{aligned}$$

The flow rate of seawater is

$$\dot{m}_{\text{sw}} = q / \left[ c_{p,sw} (T_{h,i} - T_{h,o}) \right] = 164 \times 10^6 \text{ W} / \left[ 3985 \text{ J/kg}\cdot\text{K} (10^\circ\text{C}) \right] = 4120 \text{ kg/s}$$

Recognizing that the outlet conditions of Section A (B) serve as inlet conditions to Section B (C), we may analyze the vaporizer on a section-by-section basis.

Section A The heat capacity rates are

$$\begin{aligned}
 \text{NG: } \dot{m}c_{p,l} &= 150 \text{ kg/s} \times 4200 \text{ J/kg}\cdot\text{K} = 630 \times 10^3 \text{ W/K} = C_{\text{min},A} \\
 \text{SW: } \dot{m}c_{p,sw} &= 4120 \text{ kg/s} \times 3985 \text{ J/kg}\cdot\text{K} = 16.4 \times 10^6 \text{ W/K} = C_{\text{max},A} \\
 C_{r,A} &= C_{\text{min},A} / C_{\text{max},A} = 630 \times 10^3 / 16.4 \times 10^6 = 0.0384
 \end{aligned}$$

Continued...

### PROBLEM 11.69 (Cont.)

The effectiveness is

$$\varepsilon_A = \frac{q_A}{C_{\min,A}(T_{h,i,A} - T_{c,i,A})} = \frac{50.4 \times 10^6 \text{ W}}{630 \times 10^3 \text{ W/K} \times (20 - (-155)^\circ\text{C})} = 0.457$$

and the NTU is determined from Equation 11.28b

$$\text{NTU}_A = -\frac{\ln[1 - 0.457(1 + 0.0384)]}{1 + 0.0384} = 0.620; A_A = \frac{\text{NTU}_A C_{\min,A}}{U_A} = \frac{0.620 \times 630 \times 10^3 \text{ W/K}}{150 \text{ W/m}^2 \cdot \text{K}} = 2600 \text{ m}^2$$

while the outlet temperature of the seawater is

$$T_{h,o,A} = T_{h,i,A} - q_A / C_{\max,A} = 20^\circ\text{C} - 50.4 \times 10^6 \text{ W} / 16.4 \times 10^6 \text{ W/K} = 16.9^\circ\text{C}$$

Section B The heat capacity rates are

$$\text{NG: } C_{\max,B} \rightarrow \infty$$

$$\text{SW: } \dot{m}c_{p,sw} = 4120 \text{ kg/s} \times 3985 \text{ J/kg} \cdot \text{K} = 16.4 \times 10^6 \text{ W/K} = C_{\min,B}$$

$$C_{r,B} = C_{\min,B} / C_{\max,B} = 0$$

The effectiveness is

$$\varepsilon_B = \frac{q_B}{C_{\min,B}(T_{h,i,B} - T_{c,i,B})} = \frac{q_B}{C_{\min,B}(T_{h,o,A} - T_f)} = \frac{86.3 \times 10^6 \text{ W}}{16.4 \times 10^6 \text{ W/K} \times (16.9 - (-75)^\circ\text{C})} = 0.0572$$

and the NTU is determined from Equation 11.28b

$$\text{NTU}_B = -\frac{\ln[1 - 0.0572]}{1} = 0.0588; A_B = \frac{\text{NTU}_B C_{\min,B}}{U_B} = \frac{0.0588 \times 16.4 \times 10^6 \text{ W/K}}{260 \text{ W/m}^2 \cdot \text{K}} = 3720 \text{ m}^2$$

while the outlet temperature of the seawater is

$$T_{h,o,B} = T_{h,i,B} - q_B / C_{\min,B} = 16.9^\circ\text{C} - 86.3 \times 10^6 \text{ W} / 16.4 \times 10^6 \text{ W/K} = 11.7^\circ\text{C}$$

Section C The heat capacity rates are

$$\text{NG: } \dot{m}c_{p,v} = 150 \text{ kg/s} \times 2210 \text{ J/kg} \cdot \text{K} = 332 \times 10^3 \text{ W/K} = C_{\min,C}$$

$$\text{SW: } \dot{m}c_{p,sw} = 4120 \text{ kg/s} \times 3985 \text{ J/kg} \cdot \text{K} = 16.4 \times 10^6 \text{ W/K} = C_{\max,C}$$

$$C_{r,C} = C_{\min,C} / C_{\max,C} = 332 \times 10^3 / 16.4 \times 10^6 = 0.020$$

The effectiveness is

$$\varepsilon_C = \frac{q_C}{C_{\min,C}(T_{h,i,C} - T_{c,i,C})} = \frac{q_C}{C_{\min,C}(T_{h,o,B} - T_f)} = \frac{27.5 \times 10^6 \text{ W}}{332 \times 10^3 \text{ W/K} \times (11.7 - (-75)^\circ\text{C})} = 0.958$$

Continued...



### PROBLEM 11.69 (Cont.)

and the NTU is found from Equation 11.28b

$$NTU_C = -\frac{\ln[1 - 0.958(1 + 0.020)]}{1 + 0.020} = 3.69; A_C = \frac{NTU_C C_{\min,C}}{U_C} = \frac{3.69 \times 332 \times 10^3 \text{ W/K}}{40 \text{ W/m}^2 \cdot \text{K}} = 30,600 \text{ m}^2$$

Therefore, the total heat transfer area for the vaporizer is

$$A = A_A + A_B + A_C = 2600 \text{ m}^2 + 3720 \text{ m}^2 + 30,600 \text{ m}^2 = 36,900 \text{ m}^2 \quad <$$

**COMMENTS:** (1) The scheme may not be feasible in a cold-weather port due to the potential of freezing the seawater. In cold-weather ports, approximately 2% of the natural gas will be burned, with the combustion products sent through the vaporizer to supply the necessary heating. See B. Eisentrout, S. Wintercorn and B. Weber, "Study Focuses on Six LNG Regasification Systems," *LNG Journal*, July/August, pp. 21 – 22, 2006. (2) For a counterflow vaporizer with sea water introduced at the top of the heat exchanger, the required area is  $A = 23,700 \text{ m}^2$ , a 36% size reduction. See Problem 11.70.

## PROBLEM 11.70

**KNOWN:** Inlet and outlet temperatures of natural gas and seawater in an LNG vaporizer. LNG flow rate and properties of its liquid and vapor phases, as well as phase change temperature and latent heat of vaporization. Overall heat transfer coefficients for three sections of the vaporizer. Seawater properties.

**FIND:** Required vaporizer heat transfer area.

**SCHEMATIC:**

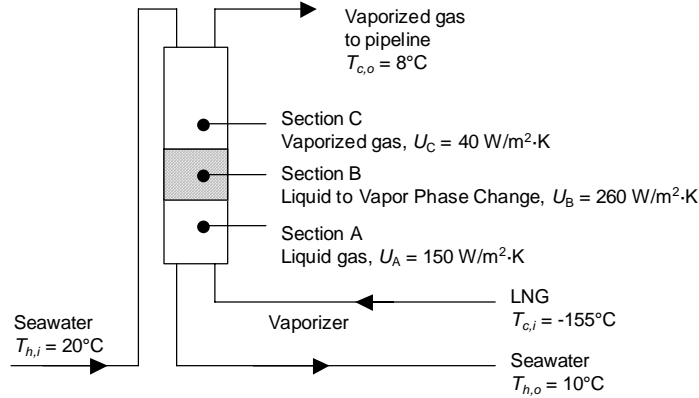

**ASSUMPTIONS:** (1) Negligible heat transfer between the heat exchanger and the surroundings, (2) Constant properties, (3) Counterflowing fluids.

**PROPERTIES:** Given. NG:  $c_{p,l} = 4200 \text{ J/kg}\cdot\text{K}$ ,  $c_{p,v} = 2210 \text{ J/kg}\cdot\text{K}$ ,  $h_{fg} = 575 \text{ kJ/kg}$ ,  $T_f = -75^\circ\text{C}$ . SW:  $c_{p,sw} = 3985 \text{ J/kg}\cdot\text{K}$ .

**ANALYSIS:** Application of the conservation of energy principle to the gas stream yields

$$\begin{aligned} q &= \dot{m}_{\text{NG}} \left[ c_{p,l} (T_f - T_{c,i}) + h_{fg} + c_{p,v} (T_{c,o} - T_f) \right] = q_A + q_B + q_C \\ &= 150 \text{ kg/s} \left[ 4200 \text{ J/kg}\cdot\text{K} (-75 - (-155)^\circ\text{C}) + 575 \times 10^3 \text{ J/kg}\cdot\text{K} + 2210 \text{ J/kg}\cdot\text{K} (8 - (-75)^\circ\text{C}) \right] \\ &= 50.4 \times 10^6 \text{ W} + 86.3 \times 10^6 \text{ W} + 27.5 \times 10^6 \text{ W} = 164 \times 10^6 \text{ W} = 164 \text{ MW} \end{aligned}$$

The flow rate of seawater is

$$\dot{m}_{\text{sw}} = q / \left[ c_{p,sw} (T_{h,i} - T_{h,o}) \right] = 164 \times 10^6 \text{ W} / \left[ 3985 \text{ J/kg}\cdot\text{K} (10^\circ\text{C}) \right] = 4120 \text{ kg/s}$$

Recognizing that the NG (cold stream) outlet conditions of Section A (B) serve as NG inlet conditions to Section B (C), and that the SW (hot stream) outlet conditions of Section C (B) serve as the SW inlet conditions for Section B(A), we may write

$$\begin{aligned} T_{h,i,C} &= T_{h,i} = 20^\circ\text{C} ; T_{h,i,B} = T_{h,i,C} - q_C / \dot{m}_{\text{sw}} c_{p,sw} = 20^\circ\text{C} - 27.5 \times 10^6 \text{ W} / (4120 \text{ kg/s} \times 3985 \text{ J/kg}\cdot\text{K}) = 18.3^\circ\text{C} \\ T_{h,i,A} &= T_{h,i,B} - q_B / \dot{m}_{\text{sw}} c_{p,sw} = 18.3^\circ\text{C} - 86.3 \times 10^6 \text{ W} / (4120 \text{ kg/s} \times 3985 \text{ J/kg}\cdot\text{K}) = 13.1^\circ\text{C} \\ T_{c,i,A} &= T_{c,i} = -155^\circ\text{C} ; T_{c,i,B} = T_f = -75^\circ\text{C} ; T_{c,i,C} = T_f = -75^\circ\text{C} \end{aligned}$$

Section A The heat capacity rates are

$$\text{NG: } \dot{m} c_{p,l} = 150 \text{ kg/s} \times 4200 \text{ J/kg}\cdot\text{K} = 630 \times 10^3 \text{ W/K} = C_{\text{min},A}$$

Continued...

### PROBLEM 11.70 (Cont.)

$$\text{SW: } \dot{m}c_{p,\text{sw}} = 4120 \text{ kg/s} \times 3985 \text{ J/kg} \cdot \text{K} = 16.4 \times 10^6 \text{ W/K} = C_{\text{max,A}}$$

$$C_{r,A} = C_{\text{min,A}} / C_{\text{max,A}} = 630 \times 10^3 / 16.4 \times 10^6 = 0.0384$$

The effectiveness is

$$\varepsilon_A = \frac{q_A}{C_{\text{min,A}}(T_{h,i,A} - T_{c,i,A})} = \frac{50.4 \times 10^6 \text{ W}}{630 \times 10^3 \text{ W/K} \times (13.1 - (-155)^\circ\text{C})} = 0.476$$

The NTU is determined from Equation 11.29b

$$\text{NTU}_A = \frac{1}{C_{r,A} - 1} \ln\left(\frac{\varepsilon_A - 1}{\varepsilon_A C_{r,A} - 1}\right) = \frac{1}{0.0384 - 1} \ln\left(\frac{0.476 - 1}{0.476 \times 0.0384 - 1}\right) = 0.653$$

and the area of Section A is

$$A_A = \frac{\text{NTU}_A C_{\text{min,A}}}{U_A} = \frac{0.653 \times 630 \times 10^3 \text{ W/K}}{150 \text{ W/m}^2 \cdot \text{K}} = 2740 \text{ m}^2$$

Section B The heat capacity rates are

$$\text{NG: } C_{\text{max,B}} \rightarrow \infty$$

$$\text{SW: } \dot{m}c_{p,\text{sw}} = 4120 \text{ kg/s} \times 3985 \text{ J/kg} \cdot \text{K} = 16.4 \times 10^6 \text{ W/K} = C_{\text{min,B}}$$

$$C_{r,A} = C_{\text{min,B}} / C_{\text{max,B}} = 0$$

The effectiveness is

$$\varepsilon_B = \frac{q_B}{C_{\text{min,B}}(T_{h,i,B} - T_{c,i,B})} = \frac{q_B}{C_{\text{min,B}}(T_{h,i,B} - T_f)} = \frac{86.3 \times 10^6 \text{ W}}{16.4 \times 10^6 \text{ W/K} \times (18.3 - (-75)^\circ\text{C})} = 0.0563$$

and the NTU is determined from Equation 11.29b

$$\text{NTU}_B = -\frac{\ln[1 - 0.0563]}{1} = 0.0579 \quad ; \quad A_B = \frac{\text{NTU}_B C_{\text{min,B}}}{U_B} = \frac{0.0579 \times 16.4 \times 10^6 \text{ W/K}}{260 \text{ W/m}^2 \cdot \text{K}} = 3660 \text{ m}^2$$

Section C The heat capacity rates are

$$\text{NG: } \dot{m}c_{p,v} = 150 \text{ kg/s} \times 2210 \text{ J/kg} \cdot \text{K} = 332 \times 10^3 \text{ W/K} = C_{\text{min,C}}$$

$$\text{SW: } \dot{m}c_{p,\text{sw}} = 4120 \text{ kg/s} \times 3985 \text{ J/kg} \cdot \text{K} = 16.4 \times 10^6 \text{ W/K} = C_{\text{max,C}}$$

$$C_{r,C} = C_{\text{min,C}} / C_{\text{max,C}} = 332 \times 10^3 / 16.4 \times 10^6 = 0.020$$

The effectiveness is

$$\varepsilon_C = \frac{q_C}{C_{\text{min,C}}(T_{h,i,C} - T_{c,i,C})} = \frac{q_C}{C_{\text{min,C}}(T_{h,i,C} - T_f)} = \frac{27.5 \times 10^6 \text{ W}}{332 \times 10^3 \text{ W/K} \times (20 - (-75)^\circ\text{C})} = 0.874$$

and the NTU is found from Equation 11.29b

Continued...

**PROBLEM 11.70 (Cont.)**

$$\text{NTU}_C = \frac{1}{0.020-1} \ln\left(\frac{0.874-1}{0.874 \times 0.020-1}\right) = 2.09; A_C = \frac{\text{NTU}_C C_{\min,C}}{U_C} = \frac{2.09 \times 332 \times 10^3 \text{ W/K}}{40 \text{ W/m}^2 \cdot \text{K}} = 17,300 \text{ m}^2$$

Therefore, the total heat transfer area for the vaporizer is

$$A = A_A + A_B + A_C = 2740 \text{ m}^2 + 3660 \text{ m}^2 + 17,300 \text{ m}^2 = 23,700 \text{ m}^2 \quad <$$

**COMMENTS:** (1) The scheme may not be feasible in a cold-weather port due to the potential of freezing the seawater. In cold-weather ports, approximately 2% of the natural gas will be burned, with the combustion products sent through the vaporizer to supply the necessary heating. See B. Eisentrout, S. Wintercorn and B. Weber, "Study Focuses on Six LNG Regasification Systems," *LNG Journal*, July/August, pp. 21 – 22, 2006. (2) For a parallel flow vaporizer with sea water introduced at the bottom of the heat exchanger, the required area is  $A = 36,900 \text{ m}^2$ , a 55% larger heat exchanger. See Problem 11.69.

## PROBLEM 11.71

**KNOWN:** Heat dissipation by electronics in sealed enclosure and dissipation from air-handling fan, mass flow rate of air, dimensions of concentric tube tower, temperature of ground water, heat transfer coefficients at top and bottom surfaces.

**FIND:** Temperature of the hot plate,  $T_2$ , for infinite and zero conduction resistance in the inner concentric tube. Determine whether maximum temperatures are maintained below  $80^\circ\text{C}$ .

**SCHEMATIC:**

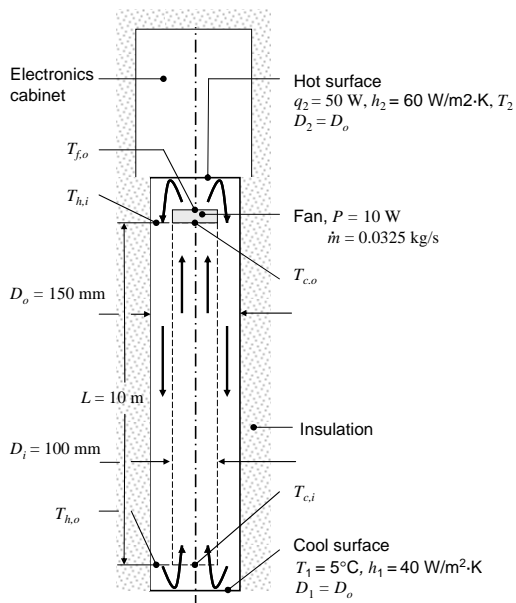

**ASSUMPTIONS:** (1) Negligible heat transfer between the device and the surroundings, (2) Constant properties.

**PROPERTIES:** Table A.4 (air) ( $\bar{T} = 300\text{ K}$ ):  $c_p = 1014\text{ J/kg}\cdot\text{K}$ ,  $\mu = 185 \times 10^{-7}\text{ N}\cdot\text{s/m}^2$ ,  $k = 0.0263\text{ W/m}\cdot\text{K}$ ,  $Pr = 0.707$ .

**ANALYSIS:** The overall heat transfer coefficient associated with the concentric tube section of the device depends on the values of the inside and outside convective heat transfer coefficients,  $h_i$  and  $h_o$ . For the inside convection coefficient, the Reynolds number is

$$Re_D = \frac{4\dot{m}}{\pi D \mu} = \frac{4 \times 0.0325\text{ kg/s}}{\pi \times 0.100\text{ m} \times 185 \times 10^{-7}\text{ N}\cdot\text{s/m}^2} = 22370$$

Since  $L/D = 10\text{ m}/0.100\text{ m} = 100$ , the flow is fully-developed and turbulent. Using the Dittus-Boelter correlation,

$$Nu_D = 0.023 \times (22370)^{4/5} \times 0.707^{0.4} = 60.43 ; h_i = 60.43 \times 0.0263\text{ W/m}\cdot\text{K} / 0.100\text{ m} = 15.90\text{ W/m}^2 \cdot \text{K}$$

For the annulus, the characteristic length is the hydraulic diameter,  $D_h = D_o - D_i = 0.150\text{ m} - 0.100\text{ m} = 0.050\text{ m}$ . Hence, the Reynolds number for the annular flow is  $Re_D = 22370 \times 2 = 44740$ . Therefore, the annular flow is also turbulent and fully-developed. Using the Dittus-Boelter correlation,

$$Nu_D = 0.023 \times (44740)^{4/5} \times 0.707^{0.3} = 108.9 ; h_o = 108.9 \times 0.0263\text{ W/m}\cdot\text{K} / 0.050\text{ m} = 57.28\text{ W/m}^2 \cdot \text{K}$$

Continued...

### PROBLEM 11.71 (Cont.)

The overall heat transfer coefficient is  $U = (1/h_i + 1/h_o)^{-1} = 12.44 \text{ W/m}^2 \cdot \text{K}$ , assuming no wall conduction resistance. The heat capacity rates of the two air streams are identical and are  $C_{\min} = C_{\max} = \dot{m} c_p = 0.0325 \text{ kg/s} \times 1014 \text{ J/kg} \cdot \text{K} = 32.73 \text{ W/K}$ . The relative heat capacity rate is  $C_r = 1$ . Hence,  $\text{NTU} = UA/C_{\min} = 12.44 \text{ W/m}^2 \cdot \text{K} \times \pi \times 0.100 \text{ m} \times 10 \text{ m} / [32.73 \text{ W/K}] = 1.19$ . From Eq. 11.29a, the effectiveness is  $\varepsilon = \text{NTU} / (1 + \text{NTU}) = 1.19 / 2.19 = 0.543$ . The heat transfer rate in the concentric tube, counter-flow heat exchanger,  $q_{\text{HX}}$ , is

$$q_{\text{HX}} = \varepsilon C_{\min} (T_{h,i} - T_{c,i}) = 0.543 \times 32.73 \text{ W/K} (T_{h,i} - T_{c,i}) \quad (1)$$

$$q_{\text{HX}} = \dot{m} c_p (T_{h,i} - T_{h,o}) = 0.0325 \text{ kg/s} \times 1014 \text{ J/kg} \cdot \text{K} (T_{h,i} - T_{h,o}) \quad (2)$$

At Surface 1, the heat flux is

$$q_1'' = \frac{(q + P)}{A_c} = \frac{(50 \text{ W} + 10 \text{ W})}{(\pi (0.15 \text{ m})^2 / 4)} = \bar{h}_1 (T_{h,o} - T_1) = 40 \text{ W/m}^2 \cdot \text{K} (T_{h,o} - T_1) \quad (3)$$

At Surface 2, the heat flux may be expressed as

$$q_2'' = \frac{q}{A_c} = \frac{50 \text{ W}}{(\pi (0.15 \text{ m})^2 / 4)} = \bar{h}_2 (T_2 - T_{f,o}) = 60 \text{ W/m}^2 \cdot \text{K} (T_2 - T_{f,o}) \quad (4)$$

By considering a control volume about the fan,

$$P = 10 \text{ W} = \dot{m} c_p (T_{f,o} - T_{c,o}) = 10 \text{ W} = 0.0325 \text{ kg/s} \times 1014 \text{ J/kg} \cdot \text{K} (T_{f,o} - T_{c,o}) \quad (5)$$

For the control volume in the vicinity of Surface 1,

$$P + q = \dot{m} c_p (T_{h,o} - T_{c,i}) = 50 \text{ W} + 10 \text{ W} = 0.0325 \text{ kg/s} \times 1014 \text{ J/kg} \cdot \text{K} \times (T_{h,o} - T_{c,i}) \quad (6)$$

For the control volume in the vicinity of Surface 2,

$$q = \dot{m} c_p (T_{h,i} - T_{f,o}) = 50 \text{ W} = 0.0325 \text{ kg/s} \times 1014 \text{ J/kg} \cdot \text{K} \times (T_{h,i} - T_{f,o}) \quad (7)$$

Equations (1) through (7) may be solved simultaneously to yield the following results.

$U = 12.44 \text{ W/m}^2 \cdot \text{K}$  (zero conduction resistance):

$T_2$	$T_{f,o}$	$T_{c,i}$	$T_{c,o}$	$T_{h,i}$	$T_{h,o}$	$q_{\text{HX}}$
137.6°C	90.49°C	88.06°C	90.19°C	92.01°C	89.88°C	70.1 W

$U = 0 \text{ W/m}^2 \cdot \text{K}$  (infinite conduction resistance):

$T_2$	$T_{f,o}$	$T_{c,i}$	$T_{c,o}$	$T_{h,i}$	$T_{h,o}$	$q_{\text{HX}}$
135.5°C	88.37°C	88.06°C	88.06°C	89.88°C	89.88°C	0 W

Neither case provides acceptable maximum temperatures.

<  
Continued...

### **PROBLEM 11.71 (Cont.)**

**COMMENTS:** (1). The heat transfer coefficients at Surfaces 1 and 2 are relatively small. Improved performance would result by increasing the surface area available for transfer through, for example, addition of fins. (2). Significantly improved performance would result by replacing the air and fan arrangement with liquid water and a pump. (3) See Hadim, Mehmedagic, and Wendell, "A New GEOPOLE Cooling Technique for Outdoor Electronic Enclosures," *International Journal of Energy Research*, Vol. 30, pp. 459 – 470, 2006, for more information.

## PROBLEM 11.72

**KNOWN:** Inlet and outlet temperatures and flow rates for a shell-and-tube heat exchanger with a single shell and 100 tubes making two passes. Tube inner and outer diameters and length. Heat transfer coefficient for ethylene-glycol water mixture flowing in shell.

**FIND:** (a) Heat transfer rate and outlet temperatures when the tubes are copper. (b) For nylon tubes, heat exchanger length required to transfer the same amount of energy as in part (a).

**SCHEMATIC:**

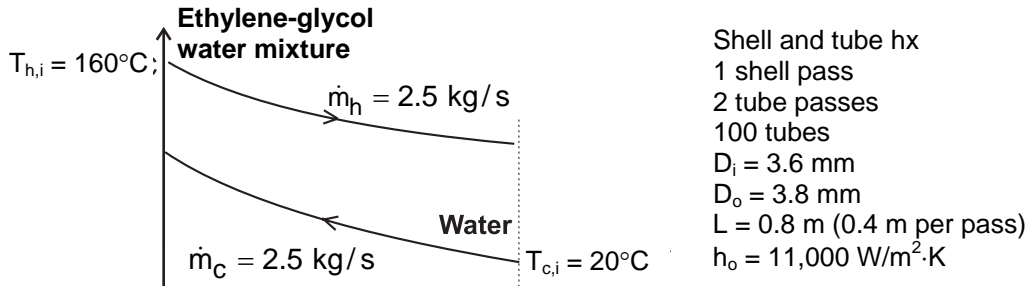

**ASSUMPTIONS:** (1) Negligible heat loss to the surroundings, (2) Constant properties, (3) Fully developed water flow in tubes.

**PROPERTIES:** Table A.6, water ( $T \approx 300$  K):  $k = 0.613$  W/m·K,  $c_p = 4179$  J/kg·K,  $\mu = 855 \times 10^{-6}$  N·s/m<sup>2</sup>,  $Pr = 5.83$ . Ethylene-glycol water mixture (given):  $\rho = 1040$  kg/m<sup>3</sup>,  $c_p = 3660$  J/kg·K. Copper ( $T \approx 300$  K):  $k_c = 401$  W/m·K. Nylon (given):  $k_n = 0.31$  W/m·K.

**ANALYSIS:** (a) We begin by finding the heat transfer coefficient for the flow in tubes. The Reynolds number is

$$Re_D = \frac{4\dot{m}_1}{\pi D_i \mu_c} = \frac{4 \times 2.5 \text{ kgs}/100}{\pi \times 0.0036 \text{ m} \times 855 \times 10^{-6} \text{ N} \cdot \text{s}/\text{m}^2} = 1.03 \times 10^4$$

Hence the flow is turbulent and we can use the Dittus-Boelter correlation,

$$h_c = (k/D_i)0.023 Re_D^{4/5} Pr^{0.4} = (0.613 \text{ W}/\text{m} \cdot \text{K}/0.0036 \text{ m})0.023(1.03 \times 10^4)^{4/5}(5.83)^{0.4} \\ = 1.29 \times 10^4 \text{ W}/\text{m}^2 \cdot \text{K}$$

Then UA can be found from

$$UA = \left[ \frac{1}{h_i \pi D_i} + \frac{\ln(D_o/D_i)}{2\pi k_c} + \frac{1}{h_o \pi D_o} \right]^{-1} LN \\ = \left[ 6.85 \times 10^{-3} + 2.15 \times 10^{-5} + 7.62 \times 10^{-3} \right]^{-1} \text{ W}/\text{m} \cdot \text{K} \times 0.8 \text{ m} \times 100 = 5522 \text{ W}/\text{K}$$

Continued...



**PROBLEM 11.72 (Cont.)**

Using the  $\varepsilon$ -NTU method,  $C_{\min} = C_h = 2.5 \text{ kg/s} \times 3600 \text{ J/kg}\cdot\text{K} = 9000 \text{ W/K}$ ,  $C_{\max} = 2.5 \text{ kg/s} \times 4179 \text{ J/kg}\cdot\text{K} = 10,450 \text{ W/K}$ ,  $C_r = 0.861$ , and  $\text{NTU} = \text{UA}/C_{\min} = 0.614$ . Then from Eq. 11.30a,

$$\varepsilon = 2 \left\{ 1 + C_r + (1 + C_r^2)^{1/2} \times \frac{1 + \exp\left[-\text{NTU}(1 + C_r^2)^{1/2}\right]}{1 - \exp\left[-\text{NTU}(1 + C_r^2)^{1/2}\right]} \right\}^{-1} = 0.378$$

and from Eqs. 11.18, 11.19, 11.6b, and 11.7b,

$$q = \varepsilon C_{\min}(T_{h,i} - T_{c,i}) = 0.378 \times 9000 \text{ W/K} (80 - 20)^\circ\text{C} = 204 \text{ kW} \quad <$$

$$T_{h,o} = T_{h,i} - q/C_h = 80^\circ\text{C} - 204,000 \text{ W}/9000 \text{ W/K} = 57.3^\circ\text{C} \quad <$$

$$T_{c,o} = T_{c,i} + q/C_c = 20^\circ\text{C} + 204,000 \text{ W}/10,450 \text{ W/K} = 42.7^\circ\text{C} \quad <$$

(b) In order to maintain the same heat rate, we must have the same effectiveness, which means that NTU and UA must be the same as in part (a). When the tubes are nylon, we can recalculate UA from Eq. (1),

$$\begin{aligned} \text{UA} &= \left[ \frac{1}{h_i \pi D_i} + \frac{\ln(D_o/D_i)}{2\pi k_n} + \frac{1}{h_o \pi D_o} \right]^{-1} \text{LN} \\ &= \left[ 6.85 \times 10^{-3} + 2.78 \times 10^{-2} + 7.62 \times 10^{-3} \right]^{-1} \text{W/m}\cdot\text{K} \times 100 \times L \text{ (m)} = 5522 \text{ W/K} \end{aligned}$$

Solving for L,

$$L = 2.33 \text{ m} \quad <$$

**COMMENTS:** (1) The nylon tube bundle is significantly larger due to nylon's low thermal conductivity relative to the copper. Based upon a nylon density of  $1150 \text{ kg/m}^3$ , the masses of the two tube bundles are 0.83 kg and 0.39 kg for the copper and nylon, respectively. The cost difference between the two raw materials is negligible. However, the nylon heat exchanger may ultimately be less expensive when assembly costs are considered. Time-consuming and expensive brazing, joining, and welding processes associated with construction of the copper heat exchanger are avoided with use of materials such as nylon. (2) With  $L/D \approx 200$ , the fully developed assumption is excellent. (3) The properties of the cold stream should have been calculated at the mean temperature of 304 K, very close to the assumed value.

### PROBLEM 11.73

**KNOWN:** Heat exchanger operating in parallel-flow configuration.

**FIND:** Expression for  $R_{lm}/R_t$  which doesn't involve temperatures. Plot result.

**SCHEMATIC:**

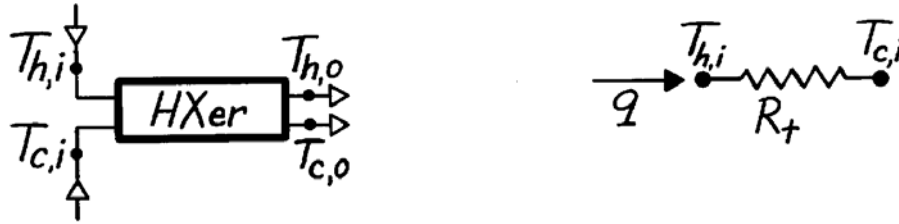

**ASSUMPTIONS:** (1) Negligible heat loss to surroundings, (2) Negligible change in kinetic and potential energy.

**ANALYSIS:** (a) For the exchanger, the rate equation is

$$q = UA\Delta T_{lm}$$

and we can define thermal resistances as

$$R_t = (T_{h,i} - T_{c,i})/q \quad \text{or} \quad R_{lm} = (\Delta T_{lm})/q = 1/UA.$$

Using the rate equation and the definition of effectiveness, find the thermal resistance based upon the inlet temperatures of the hot and cold fluids as

$$R_t = C_{min} (T_{h,i} - T_{c,i})/C_{min} \cdot q = 1/\varepsilon C_{min}.$$

The ratio of these resistances is

$$\frac{R_{lm}}{R_t} = \frac{1/UA}{1/\varepsilon C_{min}} = \frac{\varepsilon}{UA/C_{min}} = \frac{\varepsilon}{NTU}$$

and for the parallel flow, concentric tube configuration using Eq. 11.28a,

$$\frac{R_{lm}}{R_t} = \frac{1 - \exp[-NTU(1 + C_r)]}{NTU(1 + C_r)} = \frac{1 - \exp(-B)}{B}$$

where  $B = NTU(1 + C_r)$ . Evaluating the ratio for various values of  $B$ , find

$B$	$R_{lm}/R_t$
0.1	0.95
0.5	0.79
1.0	0.63
3.0	0.32
5.0	0.20
10.0	0.10

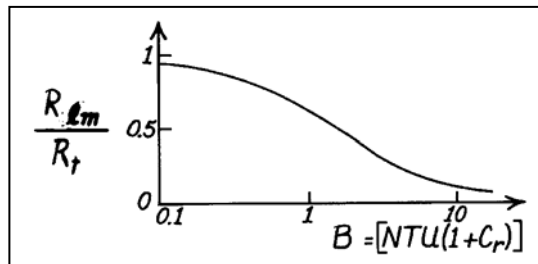

**COMMENTS:** (1) For  $C_{max} \rightarrow \infty$ ,  $C_r \rightarrow 0$ ; hence  $B \rightarrow NTU$ . (2) For  $C_{max} \approx C_{min}$ ,  $B \rightarrow 2NTU$  or  $B \sim C_{min}^{-1}$ . (3) For  $B \ll 1$ ,  $R_{lm}/R_t \rightarrow 1$ . (4) For  $B \gg 1$ ,  $R_{lm}/R_t \rightarrow B^{-1}$ . (5) We conclude that care must be taken in representing heat exchangers with a thermal resistance, recognizing that the resistance will depend on flow rates for wide ranges of conditions.

### PROBLEM 11.74

**KNOWN:** Required power for automobile. Overall heat transfer coefficient for radiator, analyzed as a cross-flow heat exchanger with both fluids unmixed. Inlet temperature of air for cooling.

**FIND:** (a) Required heat transfer area if engine efficiency is 35%, water inlet and outlet temperatures are 400 and 330 K, respectively, and air flow rate is 3 kg/s. (b) Required heat transfer area and engine coolant (water) mass flow rate if vehicle is powered by 50% efficient fuel cell, water inlet and outlet temperatures are 335 and 330 K, respectively, and air flow rate is proportional to radiator surface area. (c) Required heat transfer area and coolant (water) outlet temperature for fuel cell powered vehicle if air flow rate is 3 kg/s.

**SCHEMATIC:**

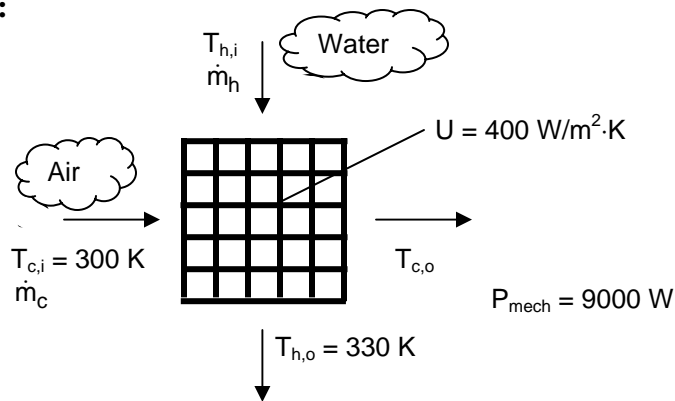

**ASSUMPTIONS:** (1) Negligible heat loss to the surroundings, (2) Constant properties, (3) Negligible fouling factors.

**PROPERTIES:** Table A.6, water: ( $\bar{T}_m = 365$  K):  $c_p = 4209$  J/kg·K; Table A.4, air ( $\bar{T}_m \approx 350$  K):  $c_p = 1009$  J/kg·K.

**ANALYSIS:** (a) We can determine how much heat must be removed by the radiator as follows. The required mechanical power is 9 kW, which is 35% of the total engine power, i.e.  $P_{tot} = 9 \text{ kW}/0.35 = 25.7 \text{ kW}$ . The waste heat is 65% of the total power, or

$$q = 0.65P_{tot} = 0.65 \times 25.7 \text{ kW} = 16.7 \text{ kW}$$

Then from Eq. 11.6b,

$$C_h = q/(T_{h,i} - T_{h,o}) = 16.7 \text{ kW}/(400 - 330)\text{K} = 239 \text{ W/K}$$

The heat capacity rate for the air is

$$C_c = (\dot{m}c_p)_c = 3 \text{ kg/s} \times 1009 \text{ J/kg} \cdot \text{K} = 3027 \text{ W/K}$$

Continued...

**PROBLEM 11.74 (Cont.)**

Thus  $C_{\min} = C_h$ ,  $C_r = 239/3027 = 0.0789$  and  $\varepsilon = q/C_{\min}(T_{h,i} - T_{h,o}) = 0.699$ . Then from Fig. 11.14,  $NTU \approx 1.25$ , and we can refine this estimate by solving Eq. 11.32 iteratively, to yield  $NTU = 1.26$ . Thus,  $UA = NTU \times C_{\min} = 1.26 \times 239 \text{ W/K} = 301 \text{ W/K}$ . With  $U = 400 \text{ W/m}^2 \cdot \text{K}$ ,

$$A = UA/U = 301 \text{ W/K} / 400 \text{ W/m}^2 \cdot \text{K} = 0.752 \text{ m}^2 \quad <$$

(b) With 50% efficiency,  $P_{\text{tot}} = 9 \text{ kW}/0.50 = 18 \text{ kW}$  and  $q = 0.50P_{\text{tot}} = 9 \text{ kW}$ . Then

$$C_h = q/(T_{h,i} - T_{h,o}) = 9 \text{ kW}/(355 - 330)\text{K} = 360 \text{ W/K}$$

and

$$\dot{m}_h = C_h / c_{p,h} = 360 \text{ W/K} / 4209 \text{ J/kg} \cdot \text{K} = 0.0855 \text{ kg/s} \quad <$$

The heat capacity rate for the air is unknown, but can be expressed as follows, where the “o” subscript refers to the baseline conditions of part (a),

$$C_c = (\dot{m}c_p)_c = (\dot{m}_o c_p)_c \frac{A}{A_o} = 3027 \text{ W/K} \frac{A}{0.752 \text{ m}^2} = (4025 \text{ W/m}^2 \cdot \text{K})A$$

Assuming the hot fluid is still the minimum fluid,  $C_{\min} = 360 \text{ W/K}$ ,

$$\varepsilon = q/C_{\min}(T_{h,i} - T_{c,i}) = 9 \text{ kW}/[360 \text{ W/K}(355 - 300)\text{K}] = 0.455 \quad (1)$$

$$C_r = (360 \text{ W/K} / 4025 \text{ W/m}^2 \cdot \text{K})A^{-1} = (0.0895 \text{ m}^2) A^{-1} \quad (2)$$

$$NTU = UA/C_{\min} = (400 \text{ W/m}^2 \cdot \text{K}/360 \text{ W/K})A = (1.11 \text{ m}^2)A \quad (3)$$

And from Eq. 11.32,

$$\varepsilon = 1 - \exp \left[ \left( \frac{1}{C_r} \right) (NTU)^{0.22} \left\{ \exp \left[ -C_r (NTU)^{0.78} \right] - 1 \right\} \right] \quad (4)$$

Substituting Eqs. (1), (2), and (3) into Eq. (4),

$$0.455 = 1 - \exp \left[ \left( \frac{A}{0.0895 \text{ m}^2} \right) (1.11 \text{ m}^{-2} A)^{0.22} \left\{ \exp \left[ -\frac{0.0895 \text{ m}^2}{A} (1.11 \text{ m}^{-2} A)^{0.78} \right] - 1 \right\} \right]$$

Solving iteratively for A results in

$$A = 0.576 \text{ m}^2 \quad <$$

Note that  $C_c = 2.30 \text{ kg/s} \times 1009 \text{ J/kg} \cdot \text{K} = 2319 \text{ W/K}$ , so that our assumption that the hot fluid is the minimum was correct.

Continued...

### PROBLEM 11.74 (Cont.)

(c) With the same coolant (water) flow rate as in part (a),  $C_h = 239 \text{ W/K}$ . Then

$$\varepsilon = q/C_{\min}(T_{h,i} - T_{c,i}) = 9 \text{ kW}/[239 \text{ W/K}(355 - 300)\text{K}] = 0.685 \quad (5)$$

$$C_r = (239 \text{ W/K} / 4025 \text{ W/m}^2\cdot\text{K})A^{-1} = (0.0594 \text{ m}^2) A^{-1} \quad (6)$$

$$NTU = UA/C_{\min} = (400 \text{ W/m}^2\cdot\text{K}/239 \text{ W/K})A = (1.67 \text{ m}^2)A \quad (7)$$

And substituting Eqs. (5), (6), and (7) into Eq. (4),

$$0.685 = 1 - \exp \left[ \left( \frac{A}{0.0594 \text{ m}^2} \right) (1.67 \text{ m}^{-2}A)^{0.22} \left\{ \exp \left[ -\frac{0.0594 \text{ m}^2}{A} (1.67 \text{ m}^{-2}A)^{0.78} \right] - 1 \right\} \right]$$

Solving iteratively for A results in

$$A = 0.723 \text{ m}^2 \quad <$$

The outlet temperature of the coolant (water) is calculated from Eq. 11.6b,

$$T_{h,o} = T_{h,i} - q/C_h = 355 \text{ K} - 9000 \text{ W}/239 \text{ W/K} = 317 \text{ K} \quad <$$

**COMMENTS:** (1) The heat that must be rejected from the radiator when the fuel cell is used is  $9000 \text{ W}/16700 \text{ W} \times 100 = 53\%$  of that associated with the internal combustion engine. (2) As seen in Part (b), using the fuel cell and increasing the flow rate of the coolant results in a significantly smaller radiator size. (3) As seen in Part (c), if the coolant flow rate is the same as that of the internal combustion engine the coolant exits the radiator at a lower value since its residence time in the radiator is larger. (4) Reduced radiator sizes will provide opportunities to enhance streamlining of the front of the vehicle and will reduce drag forces, further increasing fuel economy. The radiator size can be reduced significantly with the fuel cell in place if a metal hydride hydrogen storage system is on board and waste heat from the fuel cell is used to desorb the hydrogen, as discussed in Example 7.5.

## PROBLEM 11.75

**KNOWN:** Air conditioner modeled as a reversed Carnot heat engine, with refrigerant as the working fluid, operating between indoor and outdoor temperatures of 23 and 43°C, respectively, removing 5 kW from a building. Compressor and fan motor efficiency of 80%.

**FIND:** (a) Required motor power assuming negligible thermal resistances *between* the refrigerant in the condenser and the outside air and *between* the refrigerant in the evaporator and the inside air, and (b) Required power if thermal resistances are each  $3 \times 10^{-3}$  K/W.

**SCHEMATIC:**

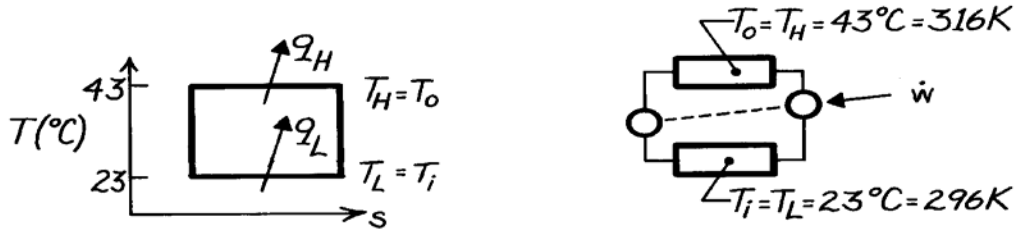

**ASSUMPTIONS:** (1) Ideal heat exchanger with no losses, (2) Air conditioner behaves as reversed Carnot engine.

**ANALYSIS:** (a) With negligible thermal resistances, the Carnot cycle and reversed heat engine can be represented as shown above. Hence, from Chapter 1

$$\dot{w}_{\text{ideal}} = q_H - q_L = q_L \left[ \left( \frac{T_H}{T_L} \right) - 1 \right] = 5 \text{ kW} \left[ \left( \frac{316 \text{ K}}{296 \text{ K}} \right) - 1 \right] = 0.3378 \text{ kW}.$$

Considering the fan power requirement and the efficiency of the motor,

$$\dot{w}_{\text{act}} = (\dot{w}_{\text{ideal}} + \dot{w}_{\text{fan}}) / \eta_c = (0.3378 + 0.200) \text{ kW} / 0.8 = 0.672 \text{ kW}. \quad <$$

(b) Consider now thermal resistances of  $R_t = 3 \times 10^{-3}$  K/W on the high temperature (condenser) and low temperature (evaporator) sides.

*Low side:* in order to remove heat from the room,  $T_C < T_i$ . That is

$$T_i - T_C = q R_t = 5 \text{ kW} \left( 3 \times 10^{-3} \text{ K/W} \right) = 15 \text{ K}$$

$$T_C = T_i - 15 \text{ K} = 23^\circ\text{C} - 15 \text{ K} = 8^\circ\text{C}.$$

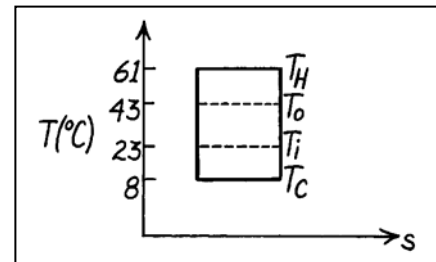

*High side:* in order to reject heat from the condenser to the outside air,  $T_H > T_o$ ,

$$T_H - T_o = q_H R_t = q_c \left( \frac{T_H}{T_C} \right) R_t$$

$$T_H - (43 + 273) \text{ K} = 5 \text{ kW} \left[ \frac{T_H}{(8 + 273)} \right] 3 \times 10^{-3} \text{ K/W} \quad T_H = 333.9 \text{ K} = 61^\circ\text{C}.$$

The work required for this cycle is

$$\dot{w}_{\text{ideal}} = q_H - q_L = q_L \left[ \left( \frac{T_H}{T_L} \right) - 1 \right] = 5 \text{ kW} \left[ \left( \frac{61 + 273}{8 + 273} \right) - 1 \right] = 0.943 \text{ kW}$$

$$\dot{w}_{\text{act}} = (\dot{w}_{\text{ideal}} + \dot{w}_{\text{fan}}) / \eta_c = (0.943 + 0.2) \text{ kW} / 0.8 = 1.43 \text{ kW}. \quad <$$

The effect of finite thermal resistances in the evaporator and condenser is to increase the power by a factor of two.

## PROBLEM 11.76

**KNOWN:** Flow rate and pressure of saturated vapor entering a condenser. Number and diameter of condenser tubes. Water flow rate and inlet temperature. Tube outside convection coefficient.

**FIND:** (a) Water outlet temperature, (b) Total tube length, (c) Effect of fouling on mass condensation, (d) Effect of water flow rate and inlet temperature on condenser performance.

**SCHEMATIC:**

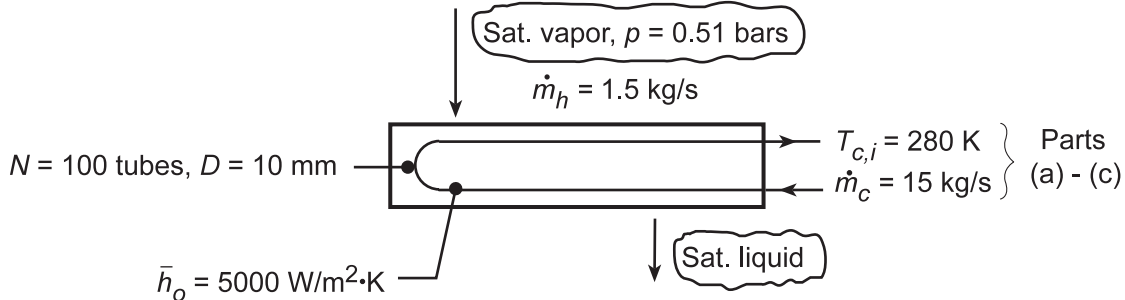

**ASSUMPTIONS:** (1) Negligible heat loss to surroundings, (2) Constant properties, (3) Negligible wall conduction resistance and fouling (initially).

**PROPERTIES:** Water (given):  $c_p = 4178 \text{ J/kg}\cdot\text{K}$ ,  $\mu = 700 \times 10^{-6} \text{ kg/s}\cdot\text{m}$ ,  $k = 0.628 \text{ W/m}\cdot\text{K}$ ,  $\text{Pr} = 4.6$ ; Table A.6, Sat. steam (355 K):  $h_{fg} = 2.304 \times 10^6 \text{ J/kg}$ ; With fouling:  $R_f'' = 0.0003 \text{ m}^2\cdot\text{K/W}$ .

**ANALYSIS:** (a) From an energy balance,  $q_h = \dot{m}_h (i_{h,i} - i_{h,o}) = \dot{m}_h h_{fg} = q_c = \dot{m}_c c_{p,c} (T_{c,o} - T_{c,i})$ , or

$$T_{c,o} = T_{c,i} + \frac{\dot{m}_h h_{fg}}{\dot{m}_c c_{p,c}} = 280 \text{ K} + \frac{1.5 \text{ kg/s} \times 2.304 \times 10^6 \text{ J/kg}}{15 \text{ kg/s} \times 4178 \text{ J/kg}\cdot\text{K}} = 335.1 \text{ K}. \quad <$$

(b) Since  $C_r = 0$ ,  $\text{NTU} = -\ln(1 - \varepsilon)$ , where

$$\varepsilon = \frac{q}{q_{\max}} = \frac{\dot{m}_c c_{p,c} (T_{c,o} - T_{c,i})}{\dot{m}_c c_{p,c} (T_{h,i} - T_{c,i})} = \frac{(335.1 - 280) \text{ K}}{(355 - 280) \text{ K}} = 0.735$$

Hence,  $\text{NTU} = -\ln(1 - 0.735) = 1.327 = \text{UA}/C_{\min}$ . The overall heat transfer coefficient is given by  $1/U = 1/\bar{h}_i + 1/\bar{h}_o$ . For the internal tube flow,

$$\text{Re}_D = \frac{4\dot{m}_{c,1}}{\pi D \mu} = \frac{4 \times 15 \text{ kg/s} / 100}{\pi (0.01 \text{ m}) 700 \times 10^{-6} \text{ kg/s}\cdot\text{m}} = 27,284$$

Hence, assuming fully developed flow with the Dittus-Boelter correlation,

$$\text{Nu}_D = 0.023 \text{Re}_D^{4/5} \text{Pr}^n = 0.023 (27,284)^{4/5} (4.6)^{0.4} = 149.8$$

$$\bar{h}_i = (k/D) \text{Nu}_D = \frac{0.628 \text{ W/m}\cdot\text{K}}{0.01 \text{ m}} 149.8 = 9408 \text{ W/m}^2\cdot\text{K}$$

and  $U = [(1/9408) + (1/5000)]^{-1} \text{ W/m}^2\cdot\text{K} = 3265 \text{ W/m}^2\cdot\text{K}$ . Hence, the heat transfer area is

$$A = \dot{m}_c c_{p,c} (\text{NTU}/U) = 15 \text{ kg/s} (4178 \text{ J/kg}\cdot\text{K}) (1.327 / 3265 \text{ W/m}^2\cdot\text{K}) = 25.5 \text{ m}^2$$

and the tube length is  $L = A/N\pi D = 25.5 \text{ m}^2 / 100\pi(0.01 \text{ m}) = 8.11 \text{ m}$ . <

(c) With fouling, the overall heat transfer coefficient is  $1/U_w = 1/U_{wo} + R_f''$ . Hence,

Continued...

**PROBLEM 11.76 (Cont.)**

$$1/U_w = \left(3.063 \times 10^{-4} + 3 \times 10^{-4}\right) \text{m}^2 \cdot \text{K}/\text{W}$$

$$U_w = 1649 \text{ W}/\text{m}^2 \cdot \text{K}.$$

$$\text{NTU} = UA/C_{\min} = \left(1649 \text{ W}/\text{m}^2 \cdot \text{K} \times 25.5 \text{ m}^2\right) / \left(15 \text{ kg}/\text{s} \times 4178 \text{ J}/\text{kg} \cdot \text{K}\right) = 0.671$$

From Eq. 11.35a,  $\varepsilon = 1 - \exp(-\text{NTU}) = 1 - \exp(-0.671) = 0.489$ . Hence,  $q = \varepsilon q_{\max} = 0.489 \times 15 \text{ kg}/\text{s} \times 4178 \text{ J}/\text{kg} \cdot \text{K}(355 - 280)\text{K} = 2.30 \times 10^6 \text{ W}$ . Without fouling the heat rate was

$$q = \dot{m}_h h_{fg} = 1.5 \text{ kg}/\text{s} \times 2.304 \times 10^6 \text{ J}/\text{kg} = 3.46 \times 10^6 \text{ W}.$$

$$\text{Hence, } \dot{m}_{h,w} / \dot{m}_{h,wo} = 2.30 \times 10^6 / 3.46 \times 10^6 = 0.666. \quad \leftarrow$$

The condensation rate with fouling is then  $\dot{m}_{h,w} = 0.666 \times 1.5 \text{ kg}/\text{s} = 0.998 \text{ kg}/\text{s}$ .

(d) The prescribed water inlet temperature of  $T_{c,i} = 280 \text{ K}$  is already at the lower limit of available sources, and it would not be feasible to consider smaller values. In addition, with  $\bar{h}_i$  already quite large, an increase in  $\dot{m}_c$  is not likely to provide a significant improvement in performance. Using the *Heat Exchanger and Correlations Tools* from IHT, the following results were obtained for  $15 \leq \dot{m}_c \leq 25 \text{ kg}/\text{s}$ .

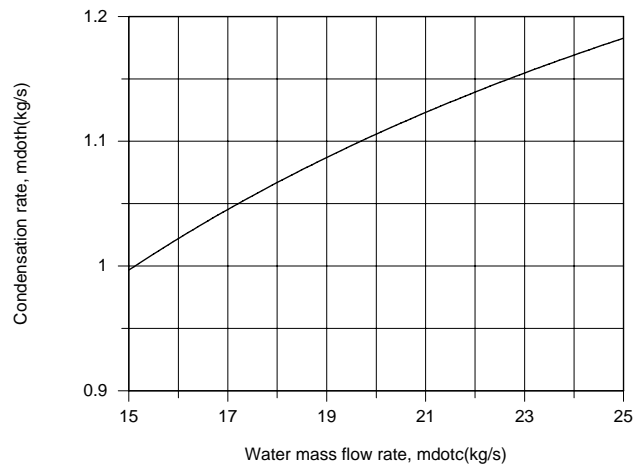

Over the specified range of  $\dot{m}_c$ , there is approximately an 18% increase in the heat rate, and hence in the condensation rate. This increase is, in part, due to the increase in  $\bar{h}_i$  from 9408 to 14,160  $\text{W}/\text{m}^2 \cdot \text{K}$ , which increases  $U$  from 1649 to 1752  $\text{W}/\text{m}^2 \cdot \text{K}$ , as well as to a reduction in  $T_{c,o}$  from 316.6 to 306.0 K, which increases the mean driving potential for heat transfer.

**COMMENTS:** There is a significant reduction in performance due to fouling, which can not be restored by increasing  $\dot{m}_c$ . The desired performance could be achieved by oversizing the condenser, that is, by increasing the number of tubes and/or the tube length.



## PROBLEM 11.77

**KNOWN:** Rankine cycle with saturated steam leaving the boiler at 2 MPa and a condenser pressure of 10 kPa. Net reversible work of 0.5 MW.

**FIND:** (a) Thermal efficiency of ideal Rankine cycle, (b) Required cooling water flow rate to condenser at 15°C with allowable temperature rise of 10°C, and (c) Design of a shell and tube heat exchanger (one shell and multiple tube passes) to satisfy condenser flow rate and temperature rise.

**SCHEMATIC:**

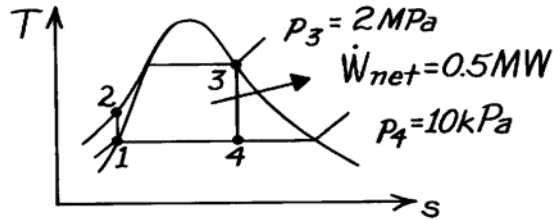

**ASSUMPTIONS:** (1) Negligible loss from condenser to surroundings, (2) Ideal Rankine cycle, and (3) Negligible thermal resistance on condensate side of exchanger tubes.

**PROPERTIES:** *Steam Tables*, (Wark, 4<sup>th</sup> Edition): (1)  $p_1 = p_4 = 10 \text{ kPa} = 0.10 \text{ bar}$ ,  $T_{\text{sat}} = 45.8^\circ\text{C} = 319 \text{ K}$ ,  $v_f = 1.0102 \times 10^{-3} \text{ m}^3/\text{kg}$ ,  $h_f = 191.83 \text{ kJ/kg}$ ; (3)  $p_2 = p_3 = 2 \text{ MPa} = 20 \text{ bar}$ ,  $h_g = 2799.5 \text{ kJ/kg}$ ,  $s_g = 6.3409 \text{ kJ/kg}\cdot\text{K}$ ; (4)  $s_4 = s_3 = 6.3409 \text{ kJ/kg}\cdot\text{K}$ ,  $p_4 = 0.10 \text{ bar}$ ,  $s_f = 0.6493 \text{ kJ/kg}\cdot\text{K}$ ,  $s_g = 8.1502 \text{ kJ/kg}\cdot\text{K}$ ,  $h_f = 191.83 \text{ kJ/kg}$ ,  $h_{fg} = 2392.8 \text{ kJ/kg}$ ; *Table A-6*, Water ( $T_{\text{sat}} = 293 \text{ K}$ ):  $c_{p,c} = 4182 \text{ J/kg}\cdot\text{K}$ ,  $\mu = 1007 \times 10^{-6} \text{ N}\cdot\text{s/m}^2$ ,  $k = 0.603 \text{ W/m}\cdot\text{K}$ ,  $\text{Pr} = 7.0$ . Note:  $1 \text{ bar} = 10^5 \text{ N/m}^2 = 10^5 \text{ Pa}$ .

**ANALYSIS:** (a) Referring to Chapter 1 and your thermodynamics text, find that

$$\eta = \frac{w_{\text{net}}}{Q_H} = \frac{w_t - w_p}{Q_H} = \frac{(h_3 - h_4) - v_1(p_2 - p_1)}{h_3 - h_2}$$

where the net work is the turbine minus the pump work. Assuming the liquid in the pump is incompressible,

$$w_p = v_1(p_2 - p_1) = 1.0102 \times 10^{-3} \text{ m}^3/\text{kg} (2 \times 10^6 - 10 \times 10^3) \text{ N/m}^2 = 2.01 \text{ kJ/kg}.$$

To find the enthalpies at states 2, 3, and 4, consider the individual processes. For the *pump*,

$$h_2 = h_1 + w_p = (191.83 + 2.01) \text{ kJ/kg} = 193.84 \text{ kJ/kg}.$$

Since the exit state of the boiler is saturated at  $p_3 = 2 \text{ MPa}$ ,

$$h_3 = h_g = 2799.5 \text{ kJ/kg}.$$

$$Q_H = h_3 - h_2 = (2799.5 - 193.84) \text{ kJ/kg} = 2605.7 \text{ kJ/kg}.$$

Since the process from 3 to 4 is isentropic,  $s_4 = s_3$ , hence

$$x_4 = (s_4 - s_f) / (s_g - s_f) = (6.3409 - 0.6493) / (8.1502 - 0.6493) = 0.759$$

$$h_4 = h_f + x h_{fg} = [191.83 + 0.759(2392.8)] \text{ kJ/kg} = 2007.5 \text{ kJ/kg}.$$

Continued ...

**PROBLEM 11.77 (Cont.)**

$$w_t = h_3 - h_4 = (2799.5 - 2007.5) \text{ kJ/kg} = 792.0 \text{ kJ/kg}.$$

Substituting appropriate values, the thermal efficiency is

$$\eta = \frac{(792.0 - 2.01) \text{ kJ/kg}}{2605.7 \text{ kJ/kg}} = 0.303 = 30.3\%.$$

<

(b) From an overall balance on the cycle, the heat rejected to the condenser is

$$Q_c = Q_H - w_{\text{net}} = [2605.7 - (792.0 - 2.01)] \text{ kJ/kg} = 1815.7 \text{ kJ/kg}.$$

Since the net reversible power is 0.5 MW, the required steam rate (h) is

$$\dot{m}_h = \dot{W}_{\text{net}} / w_{\text{net}} = 0.5 \times 10^6 \text{ W} / (792.0 - 2.01) \text{ kJ/kg} = 0.6329 \text{ kg/s}.$$

Hence, the heat rate to be removed by the cold water passing through the condenser is

$$q_c = Q_c \cdot \dot{m}_h = \dot{m}_c c_{p,c} (T_{c,\text{out}} - T_{c,\text{in}})$$

$$1815.7 \text{ kJ/kg} \times 0.6329 \text{ kg/s} = 1.149 \times 10^6 \text{ W} = \dot{m}_c \times 4182 \text{ J/kg} \cdot \text{K} (25 - 15) \text{ K}$$

$$\dot{m}_c = 27.47 \text{ kg/s}$$

<

where  $c_{p,c} = c_{p,f}$  is evaluated at  $T_2$ ,  $T_{c,\text{in}} = 15^\circ\text{C}$  and  $T_{c,\text{out}} - T_{c,\text{in}} = 10^\circ\text{C}$ , the specified allowable rise.

(c) To design the heat exchanger we need to evaluate  $UA$ . Considering the shell-tube configuration and since  $C_r = C_{\text{min}}/C_{\text{max}} = 0$ ,

$$\varepsilon = 1 - \exp(-NTU) = 1 - \exp\left[-(UA/C_{\text{min}})\right]$$

$$\varepsilon = \frac{q}{q_{\text{max}}} = \frac{q_c}{\dot{m}_c c_{p,c} (T_h - T_{c,i})}$$

$$\varepsilon = \frac{1.149 \times 10^6 \text{ W}}{27.47 \text{ kg/s} \times 4182 \text{ J/kg} \cdot \text{K} (45.7 - 15) \text{ K}} = 0.326$$

$$0.326 = 1 - \exp\left(-\frac{UA}{27.47 \text{ kg/s} \times 4182 \text{ J/kg} \cdot \text{K}}\right)$$

$$UA_s = 45,372 \text{ W/K}$$

where  $C_{\text{min}} = \dot{m}_c c_{p,c}$ . Our design process will involve the following steps: select tube diameter,  $D = 15 \text{ mm}$ ; set  $u_m = 2 \text{ m/s}$  in each tube and find number of tubes; perform internal flow calculation to estimate  $\bar{h}_c$  and then determine the length.

$$\dot{m}_c = \rho A_c \text{Nu}_m = \left(1.010 \times 10^{-3} \text{ m}^3/\text{kg}\right)^{-1} \left(\pi (0.015 \text{ m})^2 / 4\right) 2 \text{ m/s} \times N = 27.47 \text{ kg/s}$$

$$N = 78.5 \approx 79.$$

Continued ...

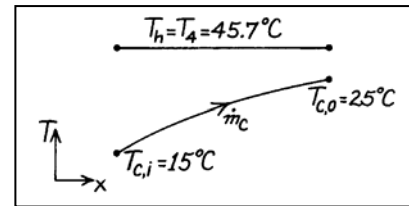

### PROBLEM 11.77 (Cont.)

For flow in a single tube,

$$\text{Re}_D = \frac{4 \dot{m}_t}{\pi D \mu} = \frac{4(27.47 \text{ kg/s}/79)}{\pi(0.015\text{m})1007 \times 10^{-6} \text{ N}\cdot\text{s}/\text{m}^2} = 29,310.$$

Assuming the flow is fully developed and using the Dittus-Boelter correlation,

$$\text{Nu} = \frac{hD}{k} = 0.023 \text{Re}_D^{0.8} \text{Pr}^{0.4} = 0.023(29,310)^{0.8} (7.00)^{0.4} = 187.7$$

$$h = 0.603 \text{ W}/\text{m}\cdot\text{K} \times 187.7/0.015\text{m} = 7544 \text{ W}/\text{m}^2 \cdot \text{K}.$$

Hence, the tube length is

$$UA_s = h(\pi DL)N = 45,372 \text{ W}/\text{K}$$

$$L = 45,372 \text{ W}/\text{K} / 7544 \text{ W}/\text{m}^2 \cdot \text{K} \times \pi(0.015\text{m})79 = 1.6\text{m}$$

and our design has the following parameters:

$$N = 79 \text{ tubes}$$

$$L = 1.6\text{m}$$

$$D = 15 \text{ mm}.$$

<

**COMMENTS:** (1) The selection of the tube diameter and water velocity values (15 mm, 2 m/s) was based upon prior experience; they seemed reasonable. We could, however, establish other requirements which would influence these choices such as allowable pressure drop and standard tube sizes.

### PROBLEM 11.78

**KNOWN:** Rankine cycle with saturated steam leaving the boiler at 2 MPa and a condenser pressure of 10 kPa. Heat rejected to the condenser of 2.3 MW. Condenser supplied with cooling water at rate of 70 kg/s at 15°C.

**FIND:** (a) Size of the condenser as determined by the parameter, UA, and (b) Reduction in thermal efficiency of the cycle if U decreases by 10% due to fouling assuming water flow rate and inlet temperature and the condenser steam pressure remain fixed.

**SCHEMATIC:**

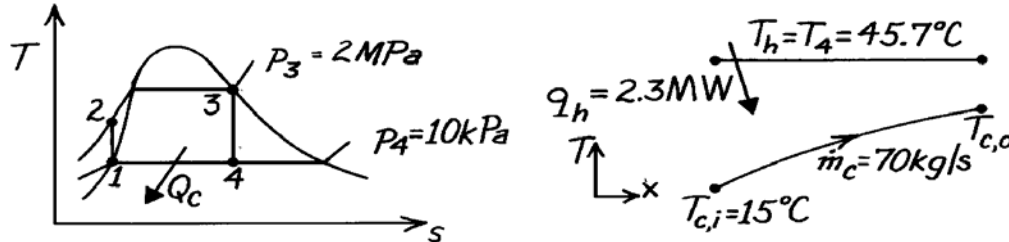

**ASSUMPTIONS:** (1) Negligible loss from condenser to surroundings, (2) Ideal Rankine cycle, (3) For fouled operating condition,  $\dot{m}_c$ ,  $T_{c,i}$  and  $p_4$  remain the same.

**PROPERTIES:** *Steam Tables* (Thermodynamics text): See previous problem for calculations to obtain cycle enthalpies;  $h_1 = 191.83$  kJ/kg,  $h_4 = 2007.5$  kJ/kg.

**ANALYSIS:** (a) For the condenser, recognize that  $C_{\min} = C_c$ , and  $C_r = C_{\min}/C_{\max} = 0$ ,

$$\varepsilon = \frac{q}{q_{\max}} = 1 - \exp(-NTU) = 1 - \exp(-UA/C_{\min})$$

$$C_{\min} = \dot{m}_c c_{p,c} = 70 \text{ kg/s} \times 4182 \text{ J/kg} \cdot \text{K} = 292,740 \text{ W/K}$$

$$q_{\max} = C_{\min} (T_h - T_{c,i}) = 292,740 \text{ W/K} (45.7 - 15) \text{ K} = 8.987 \times 10^6 \text{ W.}$$

$$q = q_h = 2.30 \times 10^6 \text{ W}$$

$$\frac{2.30 \times 10^6 \text{ W}}{8.987 \times 10^6 \text{ W}} = 0.256 = 1 - \exp\left(-\frac{UA}{292,740 \text{ W/K}}\right)$$

$$UA = 86,538 \text{ W/K.} \quad <$$

(b) In the fouled condition, U is reduced 10%, hence

$$U_f A = 0.9 UA = 77,884 \text{ W/K}$$

and

$$NTU_f = \frac{U_f A}{C_{\min}} = \frac{77,884 \text{ W/K}}{292,740 \text{ W/K}} = 0.266$$

$$\varepsilon_f = 1 - \exp(-NTU_f) = 1 - \exp(-0.266) = 0.234.$$

Continued ...

### PROBLEM 11.78 (Cont.)

If we operate the cycle at the same back pressure  $p_4 = 10 \text{ kPa}$  so that  $T_h = 45.7^\circ\text{C}$ , the heat removal rate must decrease,

$$q_h = \varepsilon q_{\max} = 0.234 \times 8.987 \times 10^6 \text{ W} = 2.103 \times 10^6 \text{ W}$$

since  $q_{\max} = C_{\min} (T_h - T_{c,i})$  remains the same. From the previous problem, we found the heat rejected as

$$h_4 - h_1 = (2007.5 - 191.83) \text{ kJ/kg} = 1815.7 \text{ kJ/kg}$$

and hence the cycle steam rate through the *fouled* condenser is

$$\dot{m}_{h,f} = q_h / (h_4 - h_1) = 2.103 \times 10^6 \text{ W} / 1815.7 \text{ kJ/kg} = 1.158 \text{ kg/s.}$$

For the *unfouled* condenser of part (a), the steam rate was

$$\dot{m}_h = 2.3 \text{ MW} / 1815.7 \text{ kJ/kg} = 1.267 \text{ kg/s.}$$

Hence, we see that fouling reduces the steam rate by 8.5% when  $U$  is decreased 10%. Since  $p_4$  remains the same, the thermal efficiency remains unchanged,

$$\eta = 30.3\%$$

<

as calculated in the previous problem. However, the net work of the cycle will decrease 8.5%.

**COMMENTS:** Fouling of the condenser heat exchanger has no effect on the thermal efficiency of the cycle since the back pressure at the condenser is maintained constant. The effect is, however, to reduce the heat rejection rate while maintaining exchanger flow rate and inlet temperature fixed. Comparing the conditions:

Parameter	Clean	Fouled	Change (%)
UA, W/K	86,538	77,884	-10.0
$\varepsilon$	0.256	0.234	-8.6
$q_h$ , MW	2.300	2.103	-8.6
$\dot{W}_{\text{net}}$	--	--	-8.6

## PROBLEM 11.79

**KNOWN:** Concentric tube heat exchanger with prescribed conditions.

**FIND:** (a) Maximum possible heat transfer, (b) Effectiveness, (c) Whether heat exchanger should be run in PF or CF to minimize size or weight; determine ratio of required areas for the two flow conditions.

**SCHEMATIC:**

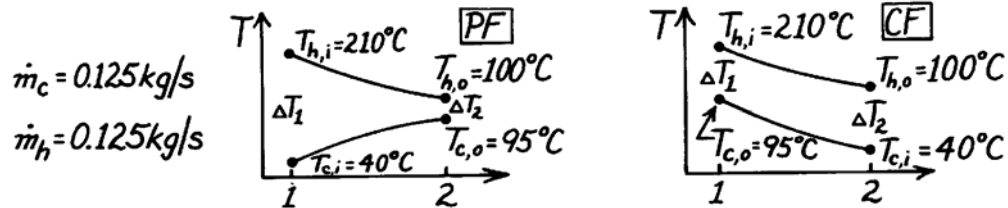

**ASSUMPTIONS:** (1) Negligible heat loss to surroundings, (2) Constant properties, (3) Overall heat transfer coefficient remains unchanged for PF or CF conditions.

**PROPERTIES:** Hot fluid (given):  $c = 2100 \text{ J/kg}\cdot\text{K}$ ; Cold fluid (given):  $c = 4200 \text{ J/kg}\cdot\text{K}$ .

**ANALYSIS:** (a) The maximum possible heat transfer rate is given by Eq. 11.18.

$$q_{\max} = C_{\min} (T_{h,i} - T_{c,o})$$

The minimum capacity fluid is the hot fluid with  $C_{\min} = \dot{m}_h c_h$ , giving

$$q_{\max} = \dot{m}_h c_h (T_{h,i} - T_{c,o}) = 0.125 \frac{\text{kg}}{\text{s}} \times 2100 \frac{\text{J}}{\text{kg}\cdot\text{K}} (210 - 40) \text{K} = 44,625 \text{ W} \quad <$$

(b) The effectiveness is defined by Eq. 11.19 and the heat rate,  $q$ , can be determined from an energy balance on the cold fluid.

$$\varepsilon = q / q_{\max} = \dot{m}_c c_c (T_{c,o} - T_{c,i}) / q_{\max}$$

$$\varepsilon = 0.125 \text{ kg/s} \times 4200 \text{ J/kg}\cdot\text{K} (95 - 40) \text{K} / 44,625 \text{ W} = 0.65 \quad <$$

(c) Operating the heat exchanger under CF conditions will require a smaller heat transfer area than for PF conditions. The ratio of the areas is

$$\frac{A_{\text{CF}}}{A_{\text{PF}}} = \frac{q / U \Delta T_{\ell m, \text{CF}}}{q / U \Delta T_{\ell m, \text{PF}}} = \frac{\Delta T_{\ell m, \text{PF}}}{\Delta T_{\ell m, \text{CF}}}$$

To calculate the LMTD, first find  $T_{h,o}$  from overall energy balances on the two fluids.

$$T_{h,o} = T_{h,i} - \frac{\dot{m}_c c_c}{\dot{m}_h c_h} (T_{c,o} - T_{c,i}) = 210^\circ\text{C} - \frac{0.125 \times 4200}{0.125 \times 2100} (95 - 40)^\circ\text{C} = 100^\circ\text{C}$$

Using Eq. 11.15 with  $\Delta T_1$  and  $\Delta T_2$  as shown below, find  $\Delta T_{\ell m} = (\Delta T_1 - \Delta T_2) / \ln(\Delta T_1 / \Delta T_2)$ .

Substituting values, find

$$\frac{A_{\text{CF}}}{A_{\text{PF}}} = \frac{[(210 - 40) - (100 - 95)] / \ln(170/5)}{[(210 - 95) - (100 - 40)] / \ln(115/60)} = \frac{46.8^\circ\text{C}}{84.5^\circ\text{C}} = 0.55 \quad <$$

**COMMENTS:** In solving part (c), it is also possible to use Figs. 11.11 and 11.12 to evaluate NTU values for corresponding  $\varepsilon$  and  $C_{\min}/C_{\max}$  values. With knowledge of NTU it is then possible to find  $A_{\text{CF}}/A_{\text{PF}}$ .

## PROBLEM 11.80

**KNOWN:** Inlet and outlet temperatures for a shell-and-tube heat exchanger with two shells, each with 10 tubes making eight passes. Heat transfer coefficient for oil flowing in shell. Mass flow rate of water in tubes. Tube diameter.

**FIND:** Is the required tube length sufficiently small to fit in an 8 m long facility, if the floor space must be at least 2.5 times the length of the heat exchanger?

**SCHEMATIC:**

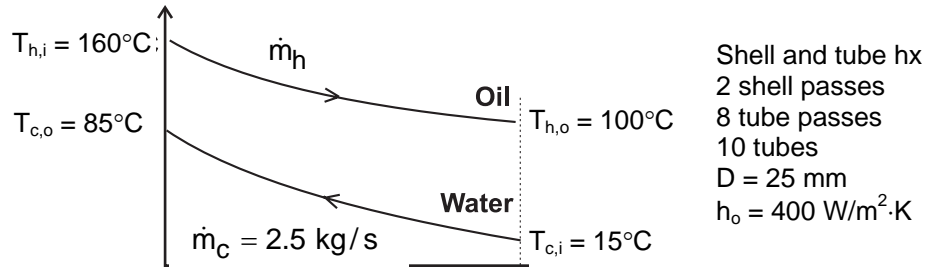

**ASSUMPTIONS:** (1) Negligible heat loss to the surroundings, (2) Constant properties, (3) Negligible tube wall thermal resistance and fouling effects, (4) Fully developed water flow in tubes.

**PROPERTIES:** Table A.5, unused engine oil: ( $\bar{T}_h = 130^\circ\text{C}$ ):  $c_p = 2350 \text{ J/kg}\cdot\text{K}$ . Table A.6, water ( $\bar{T}_c = 50^\circ\text{C}$ ):  $c_p = 4181 \text{ J/kg}\cdot\text{K}$ ,  $\mu = 548 \times 10^{-6} \text{ N}\cdot\text{s/m}^2$ ,  $k = 0.643 \text{ W/m}\cdot\text{K}$ ,  $\text{Pr} = 3.56$ .

**ANALYSIS:** From the overall energy balance, Eq. 11.7b, the heat transfer required of the exchanger is

$$q = \dot{m}_c c_{p,c} (T_{c,o} - T_{c,i}) = 2.5 \text{ kg/s} \times 4181 \text{ J/kg}\cdot\text{K} (85 - 15)^\circ\text{C} = 7.317 \times 10^5 \text{ W}$$

Hence from Eq. 11.6b,

$$\dot{m}_h = \frac{q}{c_{p,h} (T_{h,i} - T_{h,o})} = \frac{7.317 \times 10^5 \text{ W}}{2350 \text{ J/kg}\cdot\text{K} (160 - 100)^\circ\text{C}} = 5.19 \text{ kg/s}$$

The required tube length may be obtained using the  $\epsilon$ -NTU method. We first calculate the heat capacity rates,  $C_h = \dot{m}_h c_{p,h} = 12,195 \text{ W/K}$ ,  $C_c = \dot{m}_c c_{p,c} = 10,453 \text{ W/K}$ . Thus,  $C_{\min} = C_c$ , and  $C_r = C_{\min}/C_{\max} = 0.857$ . Then from Eq. 11.21,

$$\epsilon = \frac{T_{c,o} - T_{c,i}}{T_{h,i} - T_{c,i}} = \frac{(85 - 15)^\circ\text{C}}{(160 - 15)^\circ\text{C}} = 0.483$$

Using Eqs. 11.31c, 11.31b, 11.30c, 11.30b, and 11.31d, in that order, we find,  $F = 1.06$ ,  $\epsilon_1 = 0.311$ ,

Continued...

**PROBLEM 11.80 (Cont.)**

$$E = \frac{2/\varepsilon_1 - (1 + C_r)}{(1 + C_r^2)^{1/2}} = \frac{2/0.311 - (1 + 0.857)}{(1 + 0.857^2)^{1/2}} = 3.47$$

$$(\text{NTU})_1 = -(1 + C_r^2)^{-1/2} \ln\left(\frac{E - 1}{E + 1}\right) = -(1 + 0.857^2)^{-1/2} \ln\left(\frac{3.47 - 1}{3.47 + 1}\right) = 0.451$$

$$\text{NTU} = n(\text{NTU})_1 = 2 \times 0.451 = 0.901$$

Thus  $UA = \text{NTU} \times C_{\min} = 9420 \text{ W/K}$ . To find the required tube length, we must know the heat transfer coefficient for the water flow. We calculate the Reynolds number from Eq. 8.6, with the water flow rate per tube as  $\dot{m}_1 = \dot{m}_c / N = 0.25 \text{ kg/s}$ ,

$$\text{Re}_D = \frac{4\dot{m}_1}{\pi D \mu_c} = \frac{4 \times 0.25 \text{ kg/s}}{\pi(0.025 \text{ m})548 \times 10^{-6} \text{ N} \cdot \text{s/m}^2} = 23,234$$

Hence the flow is turbulent, and from Eq. 8.60,

$$\text{Nu}_D = 0.023 \text{Re}_D^{4/5} \text{Pr}^{0.4} = 0.023(23,234)^{4/5} (3.56)^{0.4} = 119$$

and

$$h_c = \frac{k_c}{D} \text{Nu}_D = \frac{0.643 \text{ W/m} \cdot \text{K}}{0.025 \text{ m}} 119 = 3060 \text{ W/m}^2 \cdot \text{K}$$

Hence  $U = [1/h_c + 1/h_h]^{-1} = 354 \text{ W/m}^2 \cdot \text{K}$  and we can find the required tube length from

$$L = \frac{UA}{UN\pi D} = \frac{9420 \text{ W/K}}{354 \text{ W/m}^2 \cdot \text{K} \times 10 \times \pi \times 0.025 \text{ m}} = 33.9 \text{ m}$$

This is the total tube length for all ten tubes in both shells, therefore the length of the heat exchanger shell must be

$$L_{\text{shell}} = L/(8 \times 2) = 2.12 \text{ m}$$

Therefore the room would have to be  $2.12 \text{ m} \times 2.5 = 5.3 \text{ m}$ .

Yes, the floorspace of 8 m is sufficiently long to service the heat exchanger. <

**COMMENTS:** (1) With  $L/D = 33.9/0.025 = 1356$ , the assumption of fully developed conditions throughout the tube is justified. (2) The floor-to-ceiling height must be sufficiently large to stack one shell above the other.



## PROBLEM 11.81

**KNOWN:** Configuration of a cubical plate-type heat exchanger with 40 gaps. Fluid flow rates, inlet temperatures, and desired oil outlet temperature.

**FIND:** (a) Core dimension,  $L$ , of the heat exchanger, when the sheet thickness is 0.8 mm, for aluminum and PVDF sheets. (b) Plot core dimension as a function of sheet thickness for aluminum and PVDF over the range  $0 \leq t \leq 1$  mm.

**SCHEMATIC:**

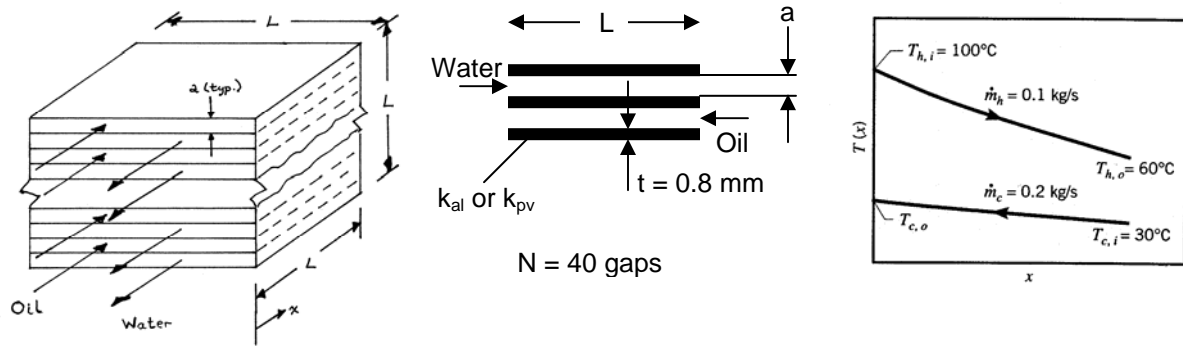

**ASSUMPTIONS:** (1) Negligible heat loss to the surroundings, (2) Constant properties, (3) Negligible fouling factors, (4) Laminar, fully developed conditions for the water and oil, (5) Identical gap-to-gap heat transfer coefficients. (6) Heat exchanger exterior dimension is large compared to the gap width.

**PROPERTIES:** Table A.6, water ( $\bar{T}_c \approx 35^\circ\text{C}$ ):  $\mu = 725 \times 10^{-6} \text{ N}\cdot\text{s}/\text{m}^2$ ,  $k = 0.625 \text{ W}/\text{m}\cdot\text{K}$ .  
 Table A.5, unused engine oil ( $\bar{T}_h = 353 \text{ K}$ ):  $\mu = 3.25 \times 10^{-2} \text{ N}\cdot\text{s}/\text{m}^2$ ,  $k = 0.138 \text{ W}/\text{m}\cdot\text{K}$ . Aluminum (given):  $k_{al} = 237 \text{ W}/\text{m}\cdot\text{K}$ . PVDF (given):  $k_{pv} = 0.17 \text{ W}/\text{m}\cdot\text{K}$ .

**ANALYSIS:** (a) From Example 11.2, assuming the flow is still laminar,

$$h_c = 7.54k/D_h = 7.54k/2a, \quad h_c a = 7.54 \times 0.625 \text{ W}/\text{m}\cdot\text{K} / 2 = 2.36 \text{ W}/\text{m}\cdot\text{K} \quad (1a)$$

$$h_h = 7.54k/D_h = 7.54k/2a, \quad h_h a = 7.54 \times 0.138 \text{ W}/\text{m}\cdot\text{K} / 2 = 0.520 \text{ W}/\text{m}\cdot\text{K} \quad (1b)$$

and the overall convection coefficient, including the wall thermal resistance, is given by

$$U^{-1} = 1/h_c + t/k_w + 1/h_h = a/(h_c a) + t/k_w + a/(h_h a) \quad (2)$$

where  $(h_c a)$  and  $(h_h a)$  are constants given by Eq. (1). In addition, from Example 11.1, the required log mean temperature difference and heat transfer rate are  $\Delta T_{lm} = 43.2^\circ\text{C}$  and  $q = 8524 \text{ W}$ , respectively. Thus with  $A = (N-1)L^2$ , we have

$$U^{-1} = \frac{A \Delta T_{lm}}{q} = \frac{39 \times 43.2^\circ\text{C} \times L^2}{8524 \text{ W}} = 0.198 \text{ K}/\text{W} L^2 \quad (3)$$

Continued...

### PROBLEM 11.81 (Cont.)

The core dimension,  $L$ , is related to the gap dimension,  $a$ , and sheet thickness,  $t$ , (neglecting the exterior plates) by the expression

$$L = Na + (N-1)t \quad (4)$$

Thus, Eq. (3) becomes

$$U^{-1} = 0.198 \text{ K/W} [Na + (N-1)t]^2 \quad (5)$$

Equating Eqs. (2) and (5), we can solve the resulting quadratic equation for  $a$ ,

$$a/(h_c a) + t/k_w + a/(h_h a) = 0.198 \text{ K/W} [Na + (N-1)t]^2$$

$$Aa^2 + Ba + C = 0, \quad a = \frac{-B \pm \sqrt{B^2 - 4AC}}{2A}$$

where

$$A = 0.198 \text{ K/W} N^2 = 0.198 \text{ K/W} \times 40^2 = 316 \text{ K/W}$$

$$B = 2(0.198 \text{ K/W})N(N-1)t - \frac{1}{h_c a} - \frac{1}{h_h a}$$

$$= 0.395 \text{ K/W} \times 40 \times 39 \times 0.0008 \text{ m} - \frac{1}{2.36 \text{ W/m} \cdot \text{K}} - \frac{1}{0.520 \text{ W/m} \cdot \text{K}} = -1.85 \text{ m} \cdot \text{K/W}$$

$$C = (0.198 \text{ W/K})(N-1)^2 t^2 - \frac{t}{k_w}$$

$$= (0.198 \text{ K/W})39^2(0.0008 \text{ m})^2 - \frac{0.0008 \text{ m}}{237 \text{ W/m} \cdot \text{K}} = 1.89 \times 10^{-4} \text{ m}^2 \cdot \text{K/W}$$

We have used  $k_w = k_{al}$  in evaluating  $C$ . Thus

$$a = \frac{-B \pm \sqrt{B^2 - 4AC}}{2A} = \frac{1.85 \pm \sqrt{1.85^2 - 4 \times 316 \times 1.89 \times 10^{-4}}}{2 \times 316} \text{ m}$$

$$= 1.04 \times 10^{-4} \text{ m or } 0.0058 \text{ m}$$

See the Comments for a discussion of the two different solutions. Hence from Eq. (4), when the sheets are aluminum,

$$L_{al} = \begin{cases} 0.0354 \text{ m} \\ 0.261 \text{ m} \end{cases} \quad <$$

Continued...

### PROBLEM 11.81 (Cont.)

Repeating the calculations for PVDF, we find only one (positive) solution,  $a = 0.00771$  m, for which

$$L_{pv} = 0.340 \text{ m}$$

(b) The calculations were keyed into the *IHT* workspace and solved for  $0 \leq t \leq 1$  mm. The solution is shown below for aluminum and PVDF sheets.

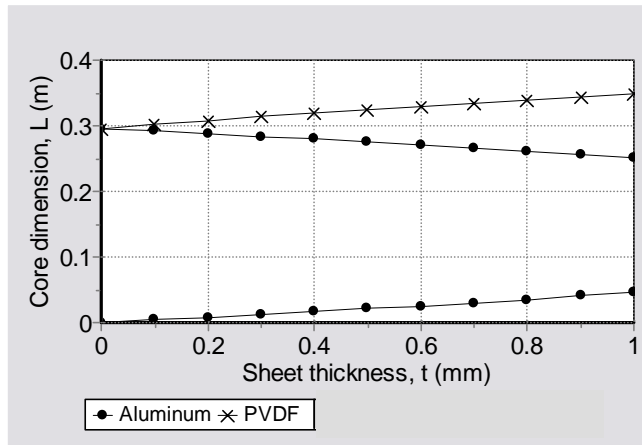

**COMMENTS:** (1) We can check the Reynolds number to see if the flow is truly laminar. The largest Reynolds number would be for water, since it is less viscous and has a higher flow rate. Thus  $Re = 4\dot{m}_1 / \mu P \approx 4\dot{m} / (N/2) / 2\mu L$ . For the smaller value of  $L$ ,  $Re = 779$ . Hence the flow is laminar for both oil and water. (2) As expected, utilization of PVDF results in a larger heat exchanger due to its lower thermal conductivity. (3) For aluminum sheets, there are two solutions. The very small spacing gives rise to high heat transfer coefficients that enable a small heat exchange area. The larger spacing corresponds to smaller heat transfer coefficients that require a larger heat exchange area. For PVDF, the thermal resistance of the sheets is larger and it is impossible to increase the value of  $U$  sufficiently to enable the smaller channel solution. (4) Manufacturing of the smaller channels would pose a challenge, and the pressure drop could be prohibitively large. Fouling could also be more of a problem in the smaller channels. (5) If the heat exchanger didn't have to be cubical, there could be solutions with superior properties with respect to pressure drop and manufacturing constraints.

## PROBLEM 11.82

**KNOWN:** Shell and tube heat exchanger for cooling exhaust gases with water.

**FIND:** Required surface area using  $\epsilon$ -NTU method.

**SCHEMATIC:**

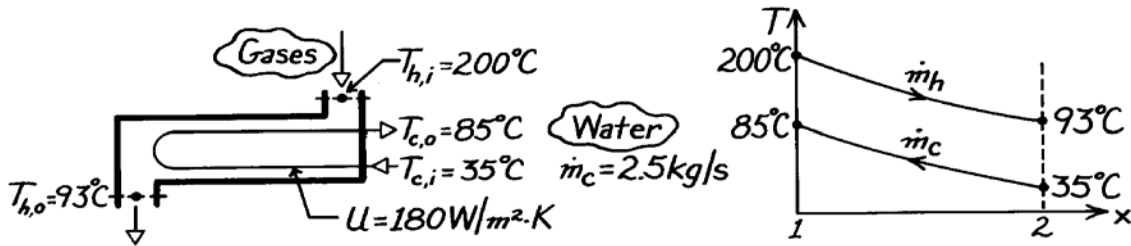

**ASSUMPTIONS:** (1) Negligible heat loss to surroundings, (2) Constant properties, (3) Gases have properties of air.

**PROPERTIES:** Table A-6, Water, liquid ( $\bar{T}_c = (85 + 35)^\circ\text{C}/2 = 333\text{ K}$ ):  $c_p = 4185\text{ J/kg}\cdot\text{K}$ .

**ANALYSIS:** Using the  $\epsilon$ -NTU method, the area can be expressed as

$$A = \text{NTU} \cdot C_{\min} / U \quad (1)$$

where NTU must be found from knowledge of  $\epsilon$  and  $C_{\min}/C_{\max} = C_r$ . The capacity rates are:

$$C_c = \dot{m}_c c_{p,c} = 2.5\text{ kg/s} \times 4185\text{ J/kg}\cdot\text{K} = 10,463\text{ W/K}$$

Equating the energy balance relation for each fluid,

$$C_h = C_c (T_{c,o} - T_{c,i}) / (T_{h,i} - T_{h,o}) = 10,463\text{ W/K} (85 - 35) / (200 - 93) = 4889\text{ W/K}.$$

Hence,

$$C_r = C_{\min} / C_{\max} = C_h / C_c = 4889 / 10,463 = 0.467.$$

The effectiveness of the exchanger, with  $q_{\max} = C_{\min} (T_{h,i} - T_{c,i})$  and  $C_{\min} = C_h$ , is

$$\epsilon = q / q_{\max} = C_h (T_{h,i} - T_{h,o}) / C_h (T_{h,i} - T_{c,i}) = (200 - 93) / (200 - 35) = 0.648.$$

Considering the HXer to be a single shell with 2,4,...tube passes, Eqs. 11.30b,c are appropriate to evaluate NTU.

$$\text{NTU} = -\left(1 + C_r^2\right)^{-1/2} \ln \frac{E - 1}{E + 1} \quad E = \frac{2/\epsilon - (1 + C_r)}{\left(1 + C_r^2\right)^{1/2}}.$$

Substituting numerical values,

$$E = \frac{2/0.648 - (1 + 0.467)}{\left(1 + 0.467^2\right)^{1/2}} = 1.467 \quad \text{NTU} = -\left(1 + (0.467)^2\right)^{-1/2} \ln \frac{1.467 - 1}{1.467 + 1} = 1.51.$$

Using the appropriate numerical values in Eq. (1), the required area is

$$A = 1.51 \times 4889\text{ W/K} / 180\text{ W/m}^2 \cdot \text{K} = 40.9\text{ m}^2. \quad \leftarrow$$

**COMMENTS:** Figure 11.12 could also have been used with  $C_r$  and  $\epsilon$  to find NTU.

### PROBLEM 11.83

**KNOWN:** Dimensions, fluid flow rates, and fluid temperatures for a counterflow heat exchanger used to heat blood.

**FIND:** (a) Outlet temperature of the blood, (b) Effect of water flowrate and inlet temperature on heat rate and blood outlet temperature.

**SCHEMATIC:**

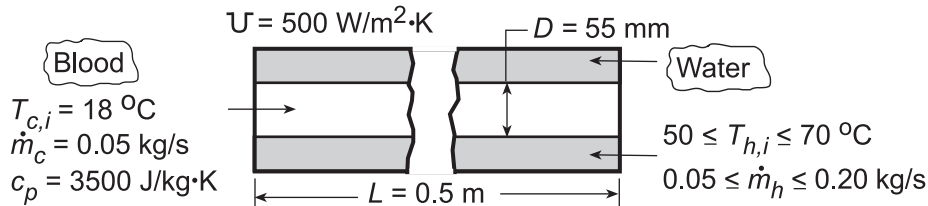

**ASSUMPTIONS:** (1) Negligible heat loss to surroundings, (2) Constant properties.

**PROPERTIES:** Table A.6, Water ( $\bar{T}_m \approx 55^\circ\text{C}$ ):  $c_p = 4183 \text{ J/kg}\cdot\text{K}$ .

**ANALYSIS:** (a) Using the  $\varepsilon$  - NTU method, we first obtain  $C_h = (\dot{m}_h c_{p,h}) = (0.10 \text{ kg/s} \times 4183 \text{ J/kg}\cdot\text{K}) = 418.3 \text{ W/K}$  and  $C_c = (\dot{m}_c c_{p,c}) = (0.05 \text{ kg/s} \times 3500 \text{ J/kg}\cdot\text{K}) = 175 \text{ W/K} = C_{\min}$ . Hence,  $(C_{\min}/C_{\max}) = 0.418$  and

$$\text{NTU} = \frac{UA}{C_{\min}} = \frac{(500 \text{ W/m}^2\cdot\text{K})\pi(0.055 \text{ m})(0.5 \text{ m})}{175 \text{ W/K}} = 0.247.$$

From Eq. 11.29a,  $\varepsilon = 0.21$ . Hence, from Eq. 11.22

$$q = \varepsilon C_{\min} (T_{h,i} - T_{c,i}) = 0.21(175 \text{ W/K})(60 - 18)^\circ\text{C} = 1544 \text{ W}.$$

From Eq. 11.7,

$$T_{c,o} = T_{c,i} + \frac{q}{C_c} = 18^\circ\text{C} + \frac{1544 \text{ W}}{175 \text{ W/K}} = 26.8^\circ\text{C}$$

(b) Because the variation of  $C_{\min}/C_{\max}$  with  $\dot{m}_h$  does not have a significant effect on  $\varepsilon$  for the prescribed NTU,  $T_{c,o}$  and  $q$  increase only slightly with increasing  $\dot{m}_h$ .

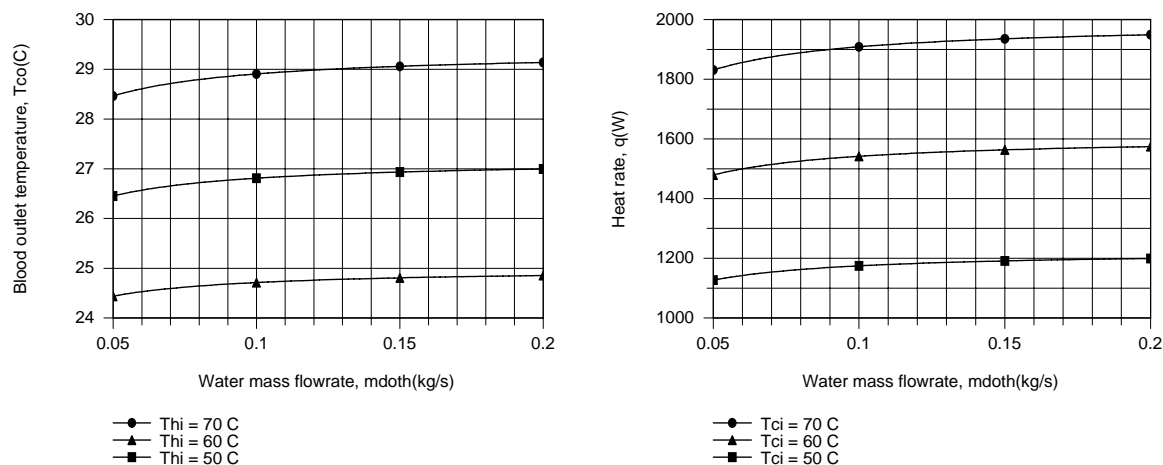

However, the water inlet temperature does have a significant effect, and accelerated heating is achieved with  $T_{h,i} = 70^\circ\text{C}$ .

**COMMENTS:** With  $\dot{m}_h = 0.2 \text{ kg/s}$  and  $T_{h,i} = 70^\circ\text{C}$ , the outlet temperature of the blood is still below the desired level of  $T_{c,o} \approx 37^\circ\text{C}$ . This value of  $T_{c,o}$  could be increased by increasing  $L$  or  $T_{h,i}$ .

## PROBLEM 11.84

**KNOWN:** Inlet temperatures and flow rates of water (c) and ethylene glycol (h) in a shell-and-tube heat exchanger (one shell pass and two tube passes) of prescribed area and overall heat transfer coefficient.

**FIND:** (a) Heat transfer rate and fluid outlet temperatures and (b) Compute and plot the effectiveness,  $\epsilon$ , and fluid outlet temperatures,  $T_{c,o}$  and  $T_{h,o}$  as a function of the flow rate of ethylene glycol,  $\dot{m}_h$ , for the range  $0.5 \leq \dot{m}_h \leq 5 \text{ kg/s}$ .

**SCHEMATIC:**

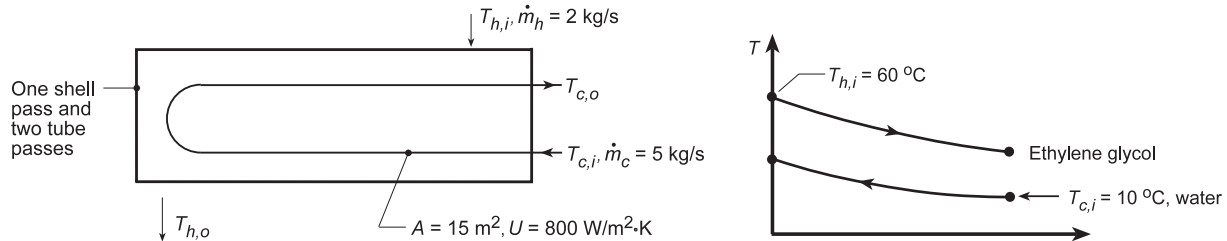

**ASSUMPTIONS:** (1) Negligible heat loss to surroundings, (2) Constant properties, and (3) Overall coefficient remains unchanged.

**PROPERTIES:** Table A-5, Ethylene glycol ( $\bar{T}_m \approx 40^\circ\text{C}$ ):  $c_p = 2474 \text{ J/kg}\cdot\text{K}$ ; Table A-6, Water ( $\bar{T}_m \approx 15^\circ\text{C}$ ):  $c_p = 4186 \text{ J/kg}\cdot\text{K}$ .

**ANALYSIS:** (a) Using the  $\epsilon$ -NTU method we first obtain

$$C_h = (\dot{m}_h c_{p,h}) = (2 \text{ kg/s} \times 2474 \text{ J/kg}\cdot\text{K}) = 4948 \text{ W/K}$$

$$C_c = (\dot{m}_c c_{p,c}) = (5 \text{ kg/s} \times 4186 \text{ J/kg}\cdot\text{K}) = 20,930 \text{ W/K}.$$

Hence with  $C_{\min} = C_h = 4948 \text{ W/K}$  and  $C_r = C_{\min}/C_{\max} = 0.236$ ,

$$\text{NTU} = \frac{UA}{C_{\min}} = \frac{(800 \text{ W/m}^2 \cdot \text{K})15 \text{ m}^2}{4948 \text{ W/K}} = 2.43.$$

From Fig. 11.12,  $\epsilon = 0.81$  and from Eq. 11.22

$$q = \epsilon C_{\min} (T_{h,i} - T_{c,i}) = 0.81(4948 \text{ W/K})(60 - 10) \text{ K} = 2 \times 10^5 \text{ W}.$$

From Eqs. 11.6 and 11.7, energy balances on the fluids,

$$T_{h,o} = T_{h,i} - \frac{q}{C_h} = 60^\circ\text{C} - \frac{2 \times 10^5 \text{ W}}{4948 \text{ W/K}} = 19.6^\circ\text{C}$$

$$T_{c,o} = T_{c,i} + \frac{q}{C_c} = 10^\circ\text{C} + \frac{2 \times 10^5 \text{ W}}{20,930 \text{ W/K}} = 19.6^\circ\text{C}.$$

(b) Using the *IHT Heat Exchanger Tool, Shell and Tube*, and the *Properties Tool* for Water and Ethylene Glycol,  $T_{c,o}$ ,  $T_{h,o}$ , and  $\epsilon$  as a function of  $\dot{m}_h$  were computed and plotted.

At very low  $C_{\min}$ , (low  $\dot{m}_h$ ) note that  $\epsilon \rightarrow 1$  while  $T_{h,o} \rightarrow T_{c,i}$ . As  $\dot{m}_h$  increases, both fluid outlet temperatures increase and the effectiveness decreases.

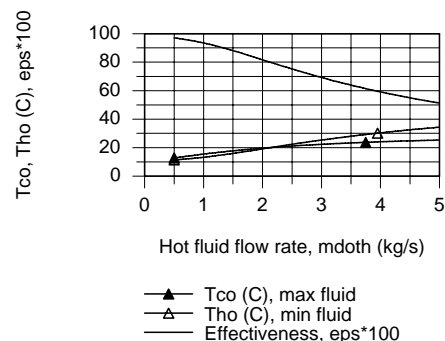

### PROBLEM 11.85

**KNOWN:** Flow rate, specific heat and inlet temperature of gas in cross-flow heat exchanger. Flow rate and temperature of water which enters as saturated liquid and leaves as saturated vapor. Number of tubes, tube diameter and overall heat transfer coefficient.

**FIND:** Required tube length.

**SCHEMATIC:**

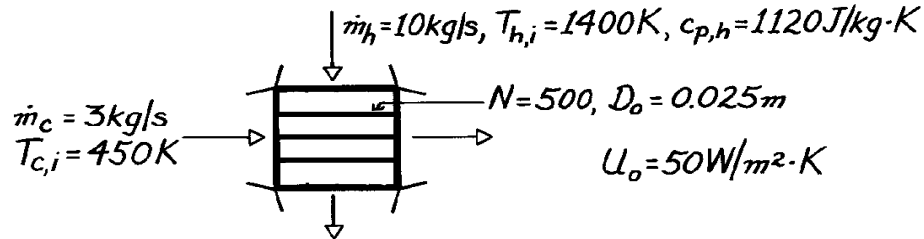

**ASSUMPTIONS:** (1) Negligible heat loss to surroundings, (2) Constant gas specific heat.

**PROPERTIES:** Table A-6, Saturated Water, ( $T = 450 \text{ K}$ ):  $h_{fg} = 2.024 \times 10^6 \text{ J/kg}$ .

**ANALYSIS:** Use effectiveness-NTU method

$$\varepsilon = \frac{q}{q_{\max}} = \frac{q}{C_{\min}(T_{h,i} - T_{c,i})} = \frac{q}{\dot{m}_h c_{p,h}(T_{h,i} - T_{c,i})}$$

$$q = \dot{m}_c h_{fg} = 3 \text{ kg/s} \times 2.024 \times 10^6 \text{ J/kg} = 6.072 \times 10^6 \text{ W}$$

$$\varepsilon = \frac{6.072 \times 10^6 \text{ W}}{10 \text{ kg/s} \times 1120 \text{ J/kg} \cdot \text{K} (1400 - 450) \text{ K}} = 0.571 \quad C_{\min} / C_{\max} = 0.$$

From Fig. 11.15, find

$$NTU \approx 0.8 \approx U_o N \pi D_o L / C_{\min}$$

$$L \approx \frac{0.8 \times 10 \text{ kg/s} \times 1120 \text{ J/kg} \cdot \text{K}}{50 \text{ W/m}^2 \cdot \text{K} \times 500 \pi \times 0.025 \text{ m}} = 4.56 \text{ m.} \quad <$$

**COMMENTS:** The gas outlet temperature is

$$T_{h,o} = T_{h,i} - q / \dot{m}_h c_{p,h} = 1400 \text{ K} - 6.072 \times 10^6 \text{ W} / 10 \text{ kg/s} \times 1120 \text{ J/kg} \cdot \text{K} = 857.9 \text{ K.}$$

## PROBLEM 11.86

**KNOWN:** Gas flow conditions upstream of a tube bank of prescribed geometry. Flow rate and inlet temperature of water passing through the tubes.

**FIND:** (a) Overall heat transfer coefficient, (b) Water and gas outlet temperatures, (c) Effect of water flow rate on heat recovery and outlet temperatures.

**SCHEMATIC:**

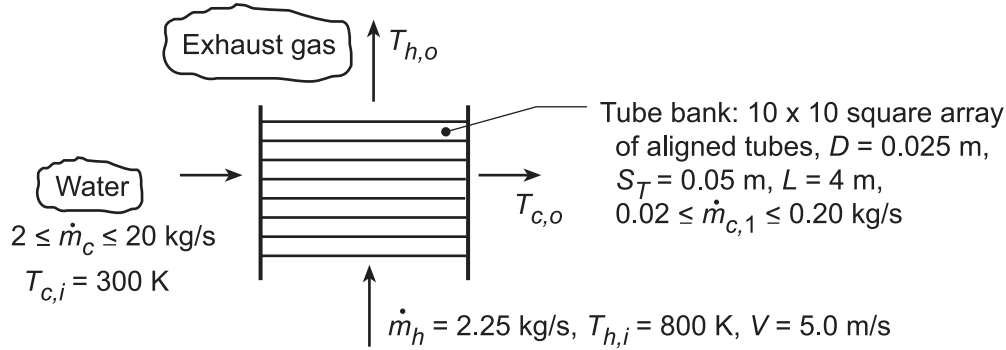

**ASSUMPTIONS:** (1) Steady-state conditions, (2) Constant properties, (3) Negligible heat loss to the surroundings, (3) Negligible tube fouling and wall thermal resistance, (4) Fully developed water flow, (5) Gas properties are those of air.

**PROPERTIES:** Table A.6, Water (Assume  $\bar{T}_m \approx 340$  K):  $c_p = 4188$  J/kg·K,  $\mu = 420 \times 10^{-6}$  N·s/m<sup>2</sup>,  $k = 0.660$  W/m·K,  $Pr = 2.66$ ; Table A.4, Air (Assume  $\bar{T}_m \approx 600$  K):  $c_p = 1051$  J/kg·K,  $\nu = 52.7 \times 10^{-6}$  m<sup>2</sup>/s,  $k = 0.047$  W/m·K,  $Pr = 0.69$ .

**ANALYSIS:** (a) For the prescribed conditions,  $U = (1/h_i + 1/h_o)^{-1}$ . For the *internal* flow, with  $\dot{m}_{c,1} = 0.025$  kg/s,

$$Re_D = \frac{4\dot{m}_{c,1}}{\pi D \mu} = \frac{4 \times 0.025 \text{ kg/s}}{\pi (0.025 \text{ m}) 420 \times 10^{-6} \text{ N}\cdot\text{s/m}^2} = 3032.$$

Hence, from the Gnielinski correlation,

$$Nu_D = \frac{(f/8)(Re_D - 1000)Pr}{1 + 12.7(f/8)^{1/2}(Pr^{2/3} - 1)} = \frac{(0.0454/8)(3032 - 1000)2.66}{1 + 12.7(0.0454/8)^{1/2}(2.66^{2/3} - 1)} = 16.3$$

where  $f = (0.79 \ln Re_D - 1.64)^{-2} = 0.0454$

$$h_i = \frac{k}{D} Nu_D = \frac{0.660 \text{ W/m}\cdot\text{K}}{0.025 \text{ m}} 16.3 = 431 \text{ W/m}^2 \cdot \text{K}.$$

For the external flow,  $V_{\max} = \frac{0.05 \text{ m}}{(0.05 - 0.025) \text{ m}} 5.0 \text{ m/s} = 10.0 \text{ m/s}$ . Hence

$$Re_{D,\max} = \frac{V_{\max} D}{\nu} = \frac{10 \text{ m/s} \times 0.025}{52.7 \times 10^{-6} \text{ m}^2/\text{s}} = 4744$$

From the Zukauskas correlation and Tables 7.5 and 7.6,  $\overline{Nu}_D = (0.97) 0.27 Re_{D,\max}^{0.63} Pr^{0.36} (Pr/Pr_s)^{1/4}$ .

Neglecting the Prandtl number ratio,

$$\overline{Nu}_D = (0.97) 0.27 (4744)^{0.63} (0.69)^{0.36} = 47.4$$

$$\overline{h}_o = \frac{k}{D} \overline{Nu}_D = \frac{0.047 \text{ W/m}\cdot\text{K}}{0.025 \text{ m}} 47.4 = 89.1 \text{ W/m}^2 \cdot \text{K}.$$

Continued...



### PROBLEM 11.86 (Cont.)

Hence,  $U = (1/431 + 1/89.1)^{-1} = 73.9 \text{ W/m}^2\cdot\text{K}$ . <

(b) The fluid outlet temperatures may be determined from the  $\epsilon$ -NTU method. With  $\dot{m}_c = 2.5 \text{ kg/s}$ ,  $C_c = \dot{m}_c c_{p,c} = 2.5 \text{ kg/s} \times 4188 \text{ J/kg}\cdot\text{K} = 10,470 \text{ W/K}$ . With  $C_h = \dot{m}_h c_{p,h} = 2.25 \text{ kg/s} \times 1051 \text{ J/kg}\cdot\text{K} = 2365 \text{ W/K}$ ,  $C_{\min}/C_{\max} = C_{\text{mixed}}/C_{\text{unmixed}} = 2365/10,470 = 0.23$ . Hence, with  $A = N\pi DL = 100\pi \times 0.025 \text{ m} \times 4 \text{ m} = 31.4 \text{ m}^2$ ,

$$\text{NTU} = \frac{UA}{C_{\min}} = \frac{73.9 \text{ W/m}^2\cdot\text{K} (31.4 \text{ m}^2)}{2365 \text{ W/K}} = 0.98$$

From Fig. 11.15,  $\epsilon \approx 0.61$ . From Eq. 11.18,  $q_{\max} = C_{\min}(T_{h,i} - T_{c,i}) = 2365 \text{ W/K}(800 - 300)\text{K} = 1.18 \times 10^6 \text{ W}$ . Hence,  $q = \epsilon q_{\max} = 0.72 \times 10^6 \text{ W}$ . From Eq. 11.6b,

$$(T_{h,i} - T_{h,o}) = \frac{q}{C_h} = \frac{0.72 \times 10^6 \text{ W}}{2365 \text{ W/K}} = 304 \text{ K} \quad T_{h,o} = 496 \text{ K} \quad <$$

From Eq. 11.7b,  $(T_{c,o} - T_{c,i}) = \frac{q}{C_c} = \frac{0.72 \times 10^6 \text{ W}}{10,470 \text{ W/K}} = 69 \text{ K} \quad T_{c,o} = 369 \text{ K} \quad <$

(c) Using the appropriate *Heat Exchangers, Correlations and Properties* Toolpads of IHT, the following results were obtained.

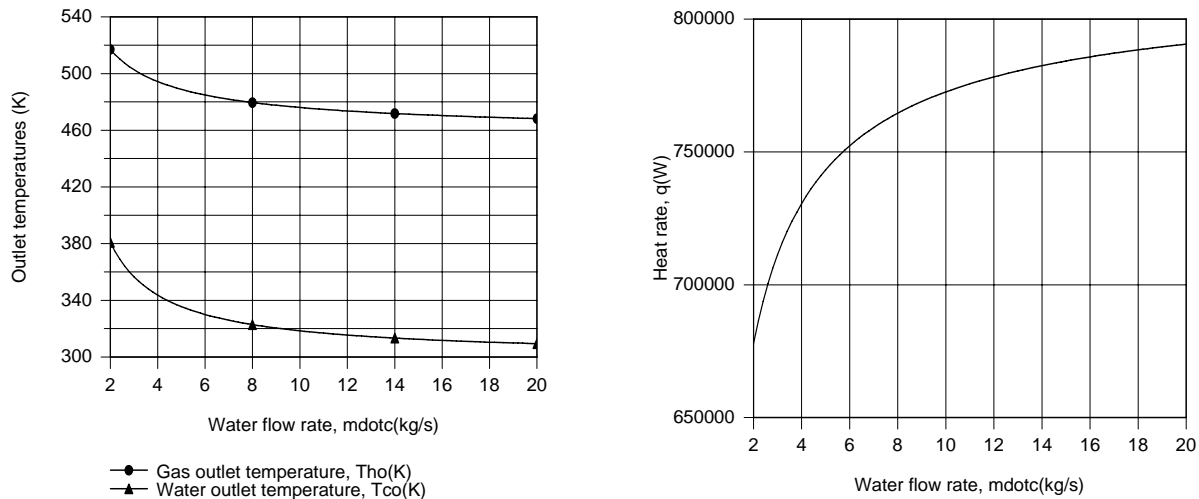

With increasing  $\dot{m}_c$  (and  $\dot{m}_{c,1}$ ),  $h_i$  increases, thereby increasing  $U$  and  $q$ . However, because the total resistance is dominated by the gas-side condition,  $\dot{m}_c = 20 \text{ kg/s}$  only yields  $U = 83.9 \text{ W/m}^2\cdot\text{K}$ , despite the fact that  $h_i = 2180 \text{ W/m}^2\cdot\text{K}$ . Because the extent to which  $q$  increases with increasing  $\dot{m}_c$  is much smaller than the increase in  $\dot{m}_c$  itself,  $T_{c,o}$  decreases with increasing  $\dot{m}_c$ . Hence, there is a trade-off between the amount of hot water and the temperature at which it is delivered. If, for example, the temperature must exceed  $50^\circ\text{C}$  ( $T_{c,o} > 323 \text{ K}$ ),  $\dot{m}_c$  cannot exceed  $8 \text{ kg/s}$ . To maintain an acceptable value of  $T_{c,o}$ , while increasing  $\dot{m}_c$ ,  $\dot{m}_h$  (and  $V$ ) should be increased, thereby increasing  $h_o$ , and hence  $U$  and  $q$ .

**COMMENTS:** If the air and water property functions of IHT are used to evaluate properties at appropriate mean values of the inlet and outlet fluid temperatures and Eq. 11.34a is used to evaluate  $\epsilon$ , the following, more accurate, results would be obtained for Parts (a) and (b):  $\epsilon = 0.565$ ,  $q = 0.677 \times 10^6 \text{ W}$ ,  $T_{c,o} = 364.6 \text{ K}$ ,  $T_{h,o} = 517.5 \text{ K}$ ,  $h_i = 383 \text{ W/m}^2\cdot\text{K}$ ,  $h_o = 86.3 \text{ W/m}^2\cdot\text{K}$  and  $U = 70.5 \text{ W/m}^2\cdot\text{K}$ .

### PROBLEM 11.87

**KNOWN:** Tube arrangement in steam-to-air, cross-flow heat exchanger. Flow rate  $\dot{m}_c$  and inlet temperature of air. Condensing temperature of steam.

**FIND:** (a) Air outlet temperature for  $\dot{m}_c = 12 \text{ kg/s}$ , (b) Effect of  $\dot{m}_c$  on air outlet temperature, heat rate and condensation rate.

**SCHEMATIC:**

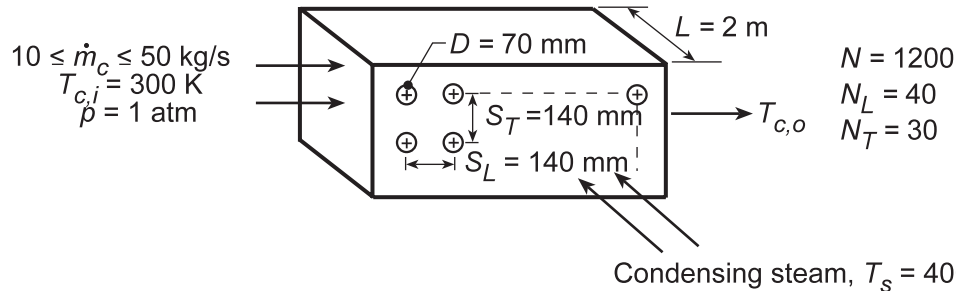

**ASSUMPTIONS:** (1) Negligible heat loss to surroundings, (2) Negligible steam side convection and tube wall conduction resistance, (3) Mean air temperature is 350 K.

**PROPERTIES:** Table A.4, Air (Assume  $\bar{T}_c \equiv (T_{c,i} + T_{c,o})/2 \approx 350 \text{ K}$ , 1 atm):  $\rho = 0.995 \text{ kg/m}^3$ ,  $c_p = 1009 \text{ J/kg}\cdot\text{K}$ ,  $\nu = 20.92 \times 10^{-6} \text{ m}^2/\text{s}$ ,  $k = 0.030 \text{ W/m}\cdot\text{K}$ ,  $\text{Pr} = 0.700$ ;  $T_s = 400 \text{ K}$ :  $\text{Pr} = 0.690$ .

**ANALYSIS:** (a) For a single-pass, cross-flow heat exchanger with one fluid mixed and the other unmixed, Fig. 11.15 can be used to obtain  $\epsilon$ , where  $C_{\min}/C_{\max} = C_{\text{mixed}}/C_{\text{unmixed}} = 0$  and  $\text{NTU} = UA/C_{\min} = U(\pi DL)N/\dot{m}_c c_p$ . From Eq. 11.5,  $U = \bar{h}_o$ , and the Zukauskas correlation may be used to estimate  $\bar{h}_o$ .

The upstream velocity may be obtained from  $\dot{m}_c = \rho VA \approx \rho V N_T L S_T$ . Hence,

$$V = \frac{\dot{m}_c}{\rho N_T L S_T} = \frac{12 \text{ kg/s}}{0.995 \text{ kg/m}^3 \times 30 \times 2 \text{ m} \times 0.14 \text{ m}} = 1.44 \text{ m/s}.$$

For aligned tubes,

$$V_{\max} = \frac{S_T}{S_T - D} V = \frac{0.14 \text{ m}}{(0.14 - 0.07) \text{ m}} 1.44 \text{ m/s} = 2.88 \text{ m/s}$$

$$\text{Re}_{D,\max} = \frac{V_{\max} D}{\nu} = \frac{2.88 \text{ m/s} \times 0.07 \text{ m}}{20.92 \times 10^{-6} \text{ m}^2/\text{s}} = 9637.$$

From Table 7.5, select values of  $C = 0.27$  and  $m = 0.63$ . Hence,

$$\overline{\text{Nu}}_D = 0.27 \text{Re}_{D,\max}^{0.63} \text{Pr}^{0.36} (\text{Pr}/\text{Pr}_s)^{0.25}$$

$$\overline{\text{Nu}}_D = 0.27 (9637)^{0.63} (0.70)^{0.36} (0.70/0.69)^{0.25} = 77.1$$

$$\bar{h}_o = \overline{\text{Nu}}_D \frac{k}{D} = 77.1 \frac{0.030 \text{ W/m}\cdot\text{K}}{0.07 \text{ m}} = 33.0 \text{ W/m}^2\cdot\text{K}.$$

Hence,

$$\text{NTU} = \frac{\bar{h}_o \pi D L N}{\dot{m}_c c_p} = \frac{33.0 \text{ W/m}^2\cdot\text{K} \times \pi (0.07 \text{ m}) 2 \text{ m} (1200)}{12 \text{ kg/s} \times 1009 \text{ J/kg}\cdot\text{K}} = 1.44.$$

From Fig. 11.15, find  $\epsilon \approx 0.77$  and then determine

Continued...

**PROBLEM 11.87 (Cont.)**

$$\varepsilon = \frac{q}{q_{\max}} = \frac{\dot{m}_c c_{p,c} (T_{c,o} - T_{c,i})}{\dot{m}_c c_{p,c} (T_s - T_{c,i})} = \frac{T_{c,o} - T_{c,i}}{T_s - T_{c,i}}$$

$$T_{c,o} = T_{c,i} + \varepsilon (T_s - T_{c,i}) = 300 \text{ K} + 0.77 (400 - 300) \text{ K} = 377 \text{ K} = 104^\circ \text{ C}$$

<

(b) With  $q = \varepsilon q_{\max} = \varepsilon C_c (T_s - T_{c,i})$  and the condensation rate given by Eqs. 10.34 and 10.27,

$$\dot{m}_{cd} = \frac{q}{h'_{fg}} \approx \frac{q}{h_{fg}}$$

the foregoing model may be used with the Heat Exchangers, Correlations and Properties Toolpads of IHT to determine the effect of  $\dot{m}_c$  on  $T_{c,o}$ ,  $q$  and  $\dot{m}_{cd}$ .

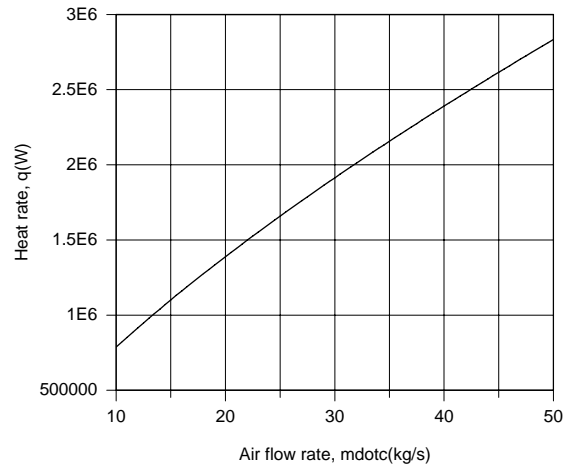
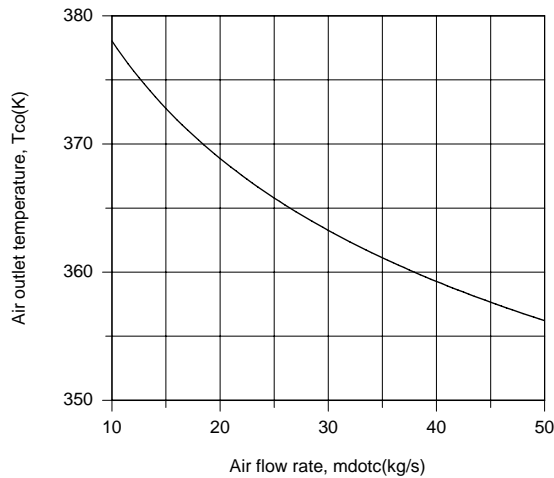

Since  $\bar{h}_o$  increases with increasing  $\dot{m}_c$ ,  $q$  must also increase. However, since the increase in  $q$  is proportionally less than the increase in  $\dot{m}_c$ ,  $T_{c,o}$  decreases with increasing  $\dot{m}_c$ .

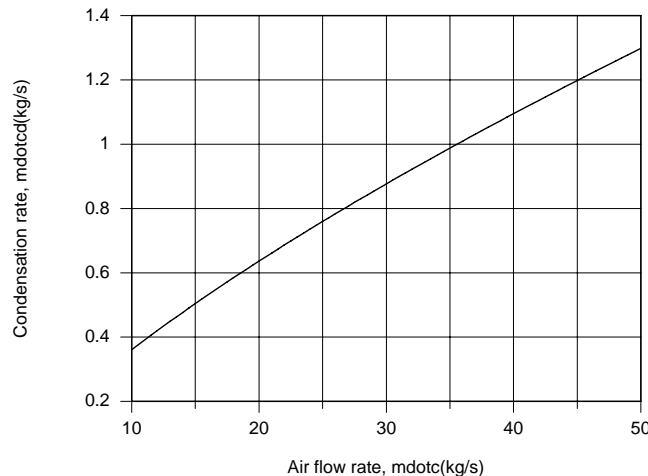

The condensation rate increases proportionally with the increase in  $q$ , and if the objective is to maximize the condensation rate, the largest value of  $\dot{m}_c$  should be maintained.

**COMMENTS:** If the objective is to heat the air, there is obviously a trade-off between maintaining elevated values of the flow rate and outlet temperature.

## PROBLEM 11.88

**KNOWN:** Steel balls cooled in an oil bath.

**FIND:** Derivation of the expression for the modified effectiveness of Comment 4 of Example 11.8.

**SCHEMATIC:**

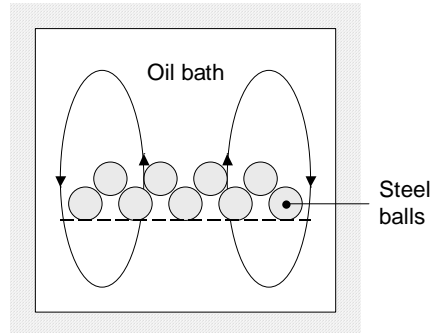

**ASSUMPTIONS:** (1) Spatially uniform bath and ball temperature at any instant, (2) Constant properties, (3) Negligible heat losses from bath.

**ANALYSIS:** From Comment 4 of Example 11.8,

$$\Delta E_{\max} = C_{t,\min}(T_{h,i} - T_{c,i}) \quad ; \quad \varepsilon^* = \frac{\Delta E}{\Delta E_{\max}} \quad ; \quad \text{NTU}^* = \frac{UA\Delta t}{C_{t,\min}} \quad (1, 2, 3)$$

Combining Eqs. (1) and (2) yields

$$\Delta E = \varepsilon^* C_{t,\min}(T_{h,i} - T_{c,i}) \quad (4)$$

Assuming  $C_{t,\min} = C_{t,h}$ , it follows that  $\varepsilon^* = \frac{T_{h,i} - T_{h,f}}{T_{h,i} - T_{c,i}}$  (5)

and therefore,

$$\frac{C_{t,\min}}{C_{t,\max}} = \frac{m_h c_h}{m_c c_c} = \frac{T_{c,f} - T_{c,i}}{T_{h,i} - T_{h,f}} \quad (6)$$

Note that Eqs. (1) through (6) are analogous to Eqs. 11.18, 11.19, 11.24, 11.22, 11.25 and 11.26 in the text.

From Comment 3 of Example 11.8,

$$\ln\left(\frac{\Delta T_2}{\Delta T_1}\right) = \ln\left(\frac{T_{h,f} - T_{c,f}}{T_{h,i} - T_{c,i}}\right) = -UA\left(\frac{1}{C_{t,h}} + \frac{1}{C_{t,c}}\right)\Delta t = -\text{NTU}^* \left(1 + \frac{C_{t,\min}}{C_{t,\max}}\right)$$

Continued...

### Problem 11.88 (Cont.)

or

$$\frac{T_{h,f} - T_{c,f}}{T_{h,i} - T_{c,i}} = \exp \left[ -NTU * \left( 1 + \frac{C_{t,\min}}{C_{t,\max}} \right) \right] \quad (7)$$

Equation (7) is identical in form to Eq. 11.27 in the text.

Noting the analogy between Eqs.(1) through (7) with the equations in the text, we may proceed in a manner identical to that of the text, after Equation 11.27, obtaining

$$\epsilon^* = \frac{1 - \exp[-NTU * (1 + C_{t,r})]}{1 + C_{t,r}} \quad <$$

**COMMENTS:** The derivation is straightforward, once the analogy between the parallel-flow concentric tube heat exchanger analysis is recognized.

## PROBLEM 11.89

**KNOWN:** Dimensions and maximum allowable temperature of an electronic chip. Thermal contact resistance between chip and heat sink. Dimensions and thermal conductivity of heat sink. Inlet temperature and convection coefficient associated with air flow through the heat sink.

**FIND:** (a) Inlet air velocity using an appropriate correlation from Chapter 8, (b) Chip power,  $q_c$  and the outlet temperature of the air exiting the channels. (c) Chip power and air outlet temperature for air velocity half of the value calculated in part (a).

### SCHEMATIC

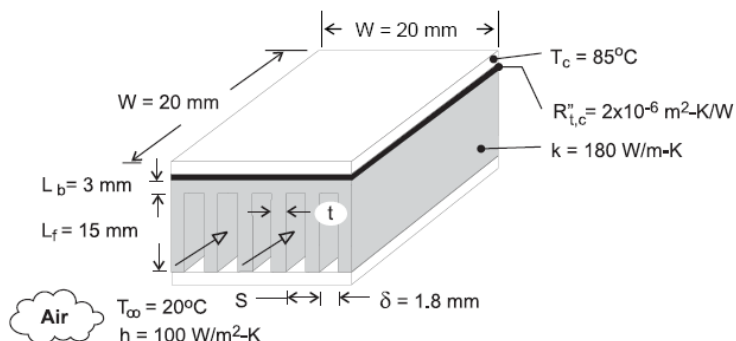

**ASSUMPTIONS:** (1) Steady state, (2) One-dimensional heat transfer in fins and base, (3) Isothermal chip, (4) Negligible heat transfer from top of chip, (5) Uniform convection coefficient over exposed surfaces, (6) Negligible radiation, (7) Negligible axial conduction in the heat sink, (8) Laminar flow, (9) Combined entry length.

**PROPERTIES:** Given. Aluminum,  $k_{hs} = 180 \text{ W/m}\cdot\text{K}$ . Air ( $T = 300 \text{ K}$ ; Table A.4)  $\rho = 1.1614 \text{ kg/m}^3$ ,  $c_p = 1007 \text{ J/kg}\cdot\text{K}$ ,  $k = 0.0263 \text{ W/m}\cdot\text{K}$ ,  $\nu = 15.89 \times 10^{-6} \text{ m}^2/\text{s}$ ,  $Pr = 0.707$ .

**ANALYSIS:** (a) The hydraulic diameter is  $D_h = 4A_c/P = 4L_f(S - t)/[2(S - t) + 2L_f] = 4 \times 0.0018 \text{ m} \times 0.015 \text{ m}/[2 \times 0.0018 \text{ m} + 2 \times 0.015 \text{ m}] = 0.00321 \text{ m}$ . From the specified convection coefficient,

$$\overline{Nu}_{D_h} = \frac{\bar{h}D_h}{k} = \frac{100 \text{ W/m}^2 \cdot \text{K} \times 0.00321 \text{ m}}{0.0263 \text{ W/m}\cdot\text{K}} = 12.22$$

$$\text{Using Eq. 8.58 } \overline{Nu}_{D_h} = 12.22 = \frac{\frac{3.66}{\tanh\left[2.264Gr_{D_h}^{-1/3} + 1.7Gz_{D_h}^{-2/3}\right]} + 0.0499Gz_{D_h} \tanh\left(Gz_{D_h}^{-1}\right)}{\tanh\left(2.432Pr^{1/6}Gz_{D_h}^{-1/6}\right)}$$

from which  $Gz_{D_h} = 204 = (D_h/W)Re_{D_h}Pr = (0.00321/0.02) \times Re_{D_h} \times 0.707$ . This yields  $Re_{D_h} = 1800$ . The flow is in the upper laminar range. From the definition of the Reynolds number,

$$u_w = \frac{Re_{D_h} \nu}{D_h} = \frac{1800 \times 15.89 \times 10^{-6} \text{ m}^2/\text{s}}{0.00321 \text{ m}} = 8.89 \text{ m/s} \quad <$$

(b) The resistances between the chip and the channel flow are due to the chip-heat sink interface ( $R_{t,c}$ ), the base of the heat sink ( $R_{t,b}$ ) and the fin array resistance ( $R_{t,o}$ ). The resistance values are:

$$R_{t,c} = R_{t,c}''/W^2 = 2 \times 10^{-6} \text{ m}^2 \cdot \text{K/W}/(0.02 \text{ m})^2 = 0.005 \text{ K/W}$$

Continued...

**PROBLEM 11.89 (Cont.)**

$$R_{t,b} = L_b / (k_{hs} W^2) = 0.003 \text{ m} / (180 \text{ W/m} \cdot \text{K} \times [0.02 \text{ m}]^2) = 0.042 \text{ K/W}$$

$$R_{t,o} = \frac{1}{\eta_o h A_t} \text{ where } \eta_o = 1 - \frac{N A_f}{A_t} (1 - \eta_f) \text{ and } A_t = N A_f + A_b$$

where  $A_f = 2WL_f = 2 \times 0.02 \text{ m} \times 0.015 \text{ m} = 6 \times 10^{-4} \text{ m}^2$  and  $A_b = W^2 - N(tW) = (0.02 \text{ m})^2 - 11(0.182 \times 10^{-3} \text{ m} \times 0.02 \text{ m}) = 3.6 \times 10^{-4} \text{ m}^2$ . With  $mL_f = (2\bar{h}/k_{hs}t)^{1/2}L_f = (200 \text{ W/m}^2 \cdot \text{K} / 180 \text{ W/m} \cdot \text{K} \times 0.182 \times 10^{-3} \text{ m})^{1/2}(0.015 \text{ m}) = 1.17$ ,  $\tanh(mL_f) = 0.824$  and Eq. (3.87) yields  $\eta_f = (\tanh mL_f) / mL_f = 0.824 / 1.17 = 0.704$ . It follows that  $A_t = 6.96 \times 10^{-3} \text{ m}^2$ ,  $\eta_o = 0.719$  and  $R_{t,o} = 2.00 \text{ K/W}$ . Accounting for the air flow within the heat sink only, the value of the minimum heat capacity rate is

$$\begin{aligned} C_{\min} &= \dot{m}c_p = u_w L_f (S - t)(N - 1)\rho c_p \\ &= 8.89 \text{ m/s} \times 0.015 \text{ m} \times 0.0018 \text{ m} \times 10 \times 1.1614 \text{ kg/m}^3 \times 1007 \text{ J/kg} \cdot \text{K} = 2.80 \text{ W/K} \end{aligned}$$

The NTU is

$$\text{NTU} = UA / C_{\min} = \frac{1}{(R_{t,c} + R_{t,b} + R_{t,o})C_{\min}} = \frac{1}{(0.005 \text{ K/W} + 0.042 \text{ K/W} + 2.00 \text{ K/W})2.80 \text{ W/K}} = 0.174$$

while the effectiveness is found from Eq. 8.35a.

$$\varepsilon = 1 - \exp(-\text{NTU}) = 1 - \exp(-0.174) = 0.160$$

yielding a heat rate of

$$q_c = 0.160 \times 2.80 \text{ W/K} (85 - 20) \text{ K} = 29.1 \text{ W} \quad <$$

The temperature of the air exiting the heat sink is found from

$$T_o = T_\infty + q_c / C_{\min} = 20^\circ\text{C} + 29.1 \text{ W} / (2.80 \text{ W/K}) = 30.4^\circ\text{C} \quad <$$

(c) If the air flow velocity is halved,  $Gz_{D_h} = 102$  and  $\bar{h} = 75.2 \text{ W/m}^2 \cdot \text{K}$

yielding  $mL_f = 1.016$  and  $\tanh(mL_f) = 0.768$ . Following the steps described in part (b),  $\eta_f = 0.769 / 1.0183 = 0.756$  and  $\eta_o = 0.768$ . Also,  $R_{t,o} = 2.48 \text{ K/W}$ ,  $\text{NTU} = 0.281$  and  $\varepsilon = 0.245$ . The heat rate is  $q_c = 22.4 \text{ W}$  and the outlet air temperature is  $T_o = 36.0^\circ\text{C}$ . <

**COMMENTS:** (1) Without accounting for the increase in the air flow temperature, the answer for Part (a) is (from Problem 3.144)  $q_c = 31.8 \text{ W}$ . As expected, the increasing air temperature, as it makes its way through the heat sink, reduces the heat transfer rate. (2) The heat rate in Part (c) is reduced because of the combined effects of (i) decreasing value of the convective heat transfer coefficient and (ii) decreasing average temperature difference between the chip and the coolant. (3) Although the flow is laminar, the value of the heat transfer coefficient is relatively high. How much would the allowable heat rate increase (or decrease) if the flow in Part (a) was treated as turbulent?

## PROBLEM 11.90

**KNOWN:** Dimensions of aluminum heat sink. Temperature and velocity of coolant (water) flow through the heat sink. Power dissipation of electronic package attached to the heat sink.

**FIND:** Base temperature of heat sink.

**SCHEMATIC:**

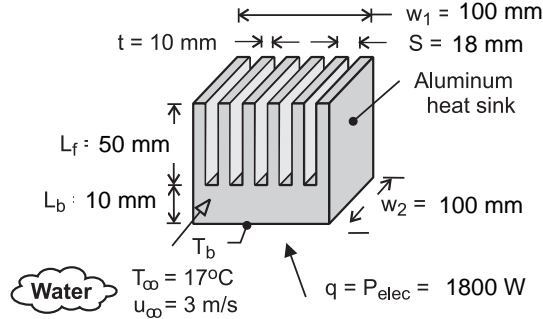

**ASSUMPTIONS:** (1) Average convection coefficient associated with water flow over fin surfaces may be approximated as that for a flat plate in parallel flow, (2) All of the electric power is dissipated by the heat sink, (3) Transition Reynolds number of  $Re_{x,c} = 5 \times 10^5$ , (4) Constant properties, (5), Water does not exit the upper surface of the heat sink.

**PROPERTIES:** Given. Aluminum,  $k_{hs} = 180 \text{ W/m}\cdot\text{K}$ . Water,  $\rho = 995 \text{ kg/m}^3$ ,  $c_p = 4178 \text{ J/kg}\cdot\text{K}$ ,  $k_w = 0.62 \text{ W/m}\cdot\text{K}$ ,  $\nu = 7.73 \times 10^{-7} \text{ m}^2/\text{s}$ ,  $Pr = 5.2$ .

**ANALYSIS:** The heat transfer rate is

$$q = P_{\text{elec}} = \varepsilon C_{\min} (T_b - T_{c,i}) = \varepsilon C_{\min} (T_b - T_{\infty}) \quad (1)$$

$$\text{where } \varepsilon = 1 - \exp(-NTU) = 1 - \exp(-UA/C_{\min}) = 1 - \exp(-1/[(R_b + R_{t,o})C_{\min}]) \quad (2)$$

The base resistance is  $R_b = L_b/k_{hs}(w_1 \times w_2) = 0.01\text{m}/180\text{W/m}\cdot\text{K}(0.10 \text{ m})^2 = 5.56 \times 10^{-3} \text{ K/W}$  and from Eqs. 3.107 and 3.108,

$$R_{t,o} = \left\{ \bar{h} A_t \left[ 1 - \frac{N A_f}{A_t} (1 - \eta_f) \right] \right\}^{-1} \quad (3)$$

The Reynolds number is  $Re_{w_2} = u_{\infty} w_2 / \nu = 3 \text{ m/s} \times 0.10 \text{ m} / 7.73 \times 10^{-7} \text{ m}^2/\text{s} = 3.88 \times 10^5$ , and the flow is laminar. Hence,

$$\bar{h} = \left( \frac{k_w}{w_2} \right) 0.664 Re_{w_2}^{1/2} Pr^{1/3} = \left( \frac{0.62 \text{ W/m}\cdot\text{K}}{0.10 \text{ m}} \right) \times 0.664 \times (3.88 \times 10^5)^{1/2} (5.2)^{1/3} = 4443 \text{ W/m}^2 \cdot \text{K}$$

The fin area is  $A_f = 2w_2(L_f + t/2) = 0.2 \text{ m} (0.055 \text{ m}) = 0.011 \text{ m}^2$  while the total surface area of the array is  $A_t = N A_f + A_b = N A_f + (N - 1)(S - t)w_2 = 6(0.011 \text{ m}^2) + 5(0.008 \text{ m})0.1 \text{ m} = 0.070 \text{ m}^2$ . The fin parameter  $m = (2\bar{h}/k_{hs}t)^{1/2} = ([2 \times 4443 \text{ W/m}^2 \cdot \text{K}] / [180 \text{ W/m}\cdot\text{K} \times 0.01 \text{ m}])^{1/2} = 70.3 \text{ m}^{-1}$  and  $L_c = L_f + t/2 = 0.050 \text{ m} + 0.010/2 \text{ m} = 0.055 \text{ m}$ . Hence, Eq. 3.94 yields  $\eta_f = \tanh(mL_c)/(mL_c) = 0.259$ .

Continued...



### PROBLEM 11.90 (Cont.)

Hence,

$$R_{t,o} = \left\{ 4443 \text{ W/m}^2 \cdot \text{K} \times 0.070 \text{ m}^2 \left[ 1 - \frac{0.066 \text{ m}^2}{0.070 \text{ m}^2} (1 - 0.259) \right] \right\}^{-1} = 0.0107 \text{ K/W}$$

The heat capacity rate is  $C_{\min} = \rho(N-1)L_f(S-t)u_{\infty}c_p = 995 \text{ kg/m}^3 \times (6-1) \times 0.050 \text{ m} \times (0.018 \text{ m} - 0.010 \text{ m}) \times 3 \text{ m/s} \times 4178 \text{ J/kg}\cdot\text{K} = 24,940$ .

Equations (1) and (2) can be combined to yield

$$\begin{aligned} T_b &= T_{\infty} + \frac{P_{\text{elec}}}{\left[ 1 - \exp\left(-\frac{1}{(R_b + R_{t,o})C_{\min}}\right) \right] C_{\min}} \\ &= 17^{\circ}\text{C} + \frac{1800 \text{ W}}{\left[ 1 - \exp\left(-\frac{1}{(5.56 \times 10^{-3} \text{ K/W} + 0.0107 \text{ K/W})24,940 \text{ W/K}}\right) \right] 24,940 \text{ W/K}} \\ &= 46.3^{\circ}\text{C}. \end{aligned}$$

<

**COMMENTS:** (1) The outlet water temperature is  $T_{c,o} = T_{c,i} + P_{\text{elec}}/C_{\min} = 17^{\circ}\text{C} + 1800 \text{ W}/24,940 \text{ W/K} = 17.1^{\circ}\text{C}$  and the assumption of constant water temperature made in Problem 7.29 is valid. (2) The hydrodynamic boundary layer thickness at the exit of the heat sink is  $\delta = 5w_2 Re_{w2}^{-1/2} = 0.80 \text{ mm}$  which is much less than  $S - t = 8 \text{ mm}$ . Hence, the assumption of flow over a flat plate is reasonable. (3) For this problem, reduced water flow rates, or use of a gaseous coolant may invalidate the assumption of constant coolant temperature and a heat exchanger-based analysis would be needed. (4) To ensure against coolant loss from the upper surface of the heat sink, a shroud would normally be added.

## PROBLEM 11.91

**KNOWN:** Dimensions of aluminum heat sink. Temperature of air entering the heat sink and specified base temperature.

**FIND:** Plot of the allowable power dissipation and air exit temperature as a function of air velocity over the range  $1 \text{ m/s} \leq u_\infty \leq 5 \text{ m/s}$ .

**SCHEMATIC:**

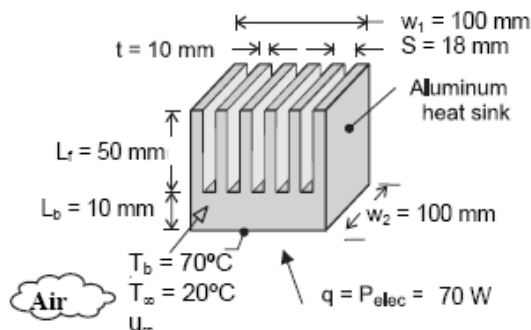

**ASSUMPTIONS:** (1) Average convection coefficient associated with air flow over fin surfaces may be approximated as that for a channel composed of isothermal parallel plates of width  $L_f$ , (2) All of the electric power is dissipated by the heat sink, (3) Laminar flow, (4) Constant properties, (5), Air does not exit through the upper surface of the heat sink.

**PROPERTIES:** Given. Aluminum,  $k_{hs} = 180 \text{ W/m}\cdot\text{K}$ . Air,  $\rho = 1.145 \text{ kg/m}^3$ ,  $c_p = 1007 \text{ J/kg}\cdot\text{K}$ ,  $k = 0.027 \text{ W/m}\cdot\text{K}$ ,  $\nu = 16.4 \times 10^{-6} \text{ m}^2/\text{s}$ ,  $Pr = 0.706$ .

**ANALYSIS:** Assuming laminar flow, from Eq. 8.58 the average Nusselt number (for a hydraulic diameter of  $D_h = 4A_c/P = 4L_f(S-t)/[2(S-t) + 2L_f] = 4 \times 0.05 \text{ m} \times (0.018 \text{ m} - 0.010 \text{ m})/[2 \times (0.018 \text{ m} - 0.010 \text{ m}) + 2 \times 0.050 \text{ m}] = 0.0138 \text{ m}$ ) is,

$$\overline{Nu}_{D_h} = \frac{\frac{3.66}{\tanh\left[2.264Gr_{D_h}^{-1/3} + 1.7Gz_{D_h}^{-2/3}\right]} + 0.0499Gz_{D_h} \tanh\left(Gz_{D_h}^{-1}\right)}{\tanh\left(2.432Pr^{1/6}Gz_{D_h}^{-1/6}\right)} \quad (1a)$$

$$\text{where } Gz_{D_h} = (D_h / w_2)Re_{D_h}Pr = (0.0138 / 0.01) \times (u_{\text{air}} \times 0.0138 \text{ m} / 16.4 \times 10^{-6} \text{ m}^2/\text{s}) \times 0.706 \quad (1b)$$

$$\text{and } \bar{h} = Nu_{D_h}k / D_h = Nu_{D_h} \times 0.027 \text{ W/m}\cdot\text{K} / 0.0138 \text{ m} \quad (1c)$$

The total resistance consists of the base and fin resistances in series. The base resistance is  $R_b = L_b/k_{hs}(w_1 \times w_2) = 0.01\text{m}/180\text{W/m}\cdot\text{K}(0.10 \text{ m})^2 = 5.56 \times 10^{-3} \text{ K/W}$  and from Eqs. 3.107 and 3.108,

$$R_{t,o} = \left\{ \bar{h}A_t \left[ 1 - \frac{NA_f}{A_t}(1 - \eta_f) \right] \right\}^{-1} \quad (2)$$

The fin area is  $A_f = 2w_2(L_f + t/2) = 0.2 \text{ m} (0.055 \text{ m}) = 0.011 \text{ m}^2$  while the total surface area of the array is  $A_t = NA_f + A_b = NA_f + (N - 1)(S - t)w_2 = 6(0.011 \text{ m}^2) + 5(0.008 \text{ m})0.1 \text{ m} = 0.070 \text{ m}^2$ . To find the fin efficiency, note that the fin parameter,  $m$ , is

Continued...

### PROBLEM 11.91 (Cont.)

$$m = (2\bar{h}/k_{hs}t)^{1/2} = ([2 \times \bar{h} \text{ W/m}^2\cdot\text{K}]/[180 \text{ W/m}\cdot\text{K} \times 0.01 \text{ m}])^{1/2} \quad (3)$$

and  $L_c = L_f + t/2 = 0.050 \text{ m} + 0.010/2 \text{ m} = 0.055 \text{ m}$ . From Eq. 3.94, the fin array efficiency is

$$\eta_f = \tanh(mL_c)/(mL_c) = \tanh(m \times 0.055 \text{ m})/(m \times 0.055 \text{ m}) \quad (4)$$

The minimum heat capacity rate is

$$\begin{aligned} C_{\min} &= u_{\infty} \rho c_p (N-1)(S-t)L_f \\ &= u_{\infty} \times 1.145 \text{ kg/m}^3 \times 1007 \text{ J/kg}\cdot\text{K} \times (6-1) \times (0.018 \text{ m} - 0.010 \text{ m}) \times 0.050 \text{ m} \end{aligned} \quad (5)$$

and the effectiveness is

$$\begin{aligned} \varepsilon &= 1 - \exp(-NTU) = 1 - \exp(-UA/C_{\min}) = 1 - \exp\left(-\frac{1}{(R_{t,o} + R_b)C_{\min}}\right) \\ &= 1 - \exp\left(-\frac{1}{(R_{t,o} + 5.56 \times 10^{-3} \text{ K/W})C_{\min}}\right) \end{aligned} \quad (6)$$

The heat transfer rate may be expressed as

$$q = P_{\text{elec}} = \varepsilon C_{\min} (T_b - T_{\infty}) = \varepsilon C_{\min} (70^{\circ}\text{C} - 20^{\circ}\text{C}) \quad (7)$$

and the outlet air temperature is

$$T_o = T_{\infty} + P_{\text{elec}}/C_{\min} \quad (8)$$

Equations 1 through 7 can be solved using IHT as noted in Comment 1. The allowable power and exit air temperatures are shown below.

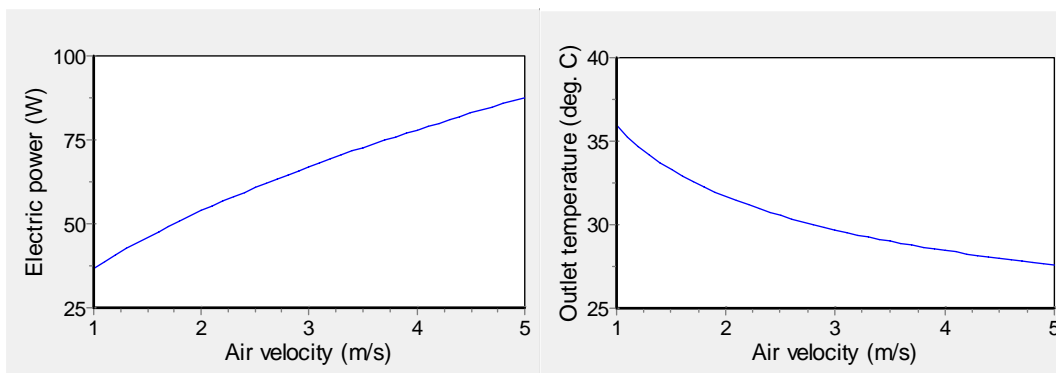

Continued...

## PROBLEM 11.91 (Cont.)

**COMMENTS:** (1) The IHT code is shown below. (2) Values of the Reynolds number range from 841 to 4205 for air velocities ranging from 1 m/s to 5 m/s. Hence, the flow will be transitioning to a turbulent state at velocities greater than approximately 3 m/s. (3) To dissipate  $P_{\text{elec}} = 70 \text{ W}$ , it is necessary to provide an air velocity of  $u_{\infty} = 3.3 \text{ m/s}$ , corresponding to a Reynolds number of 2775. (4) Increasing air velocity has two effects, (i) the heat transfer coefficient is increased (from 13 to  $28 \text{ W/m}^2\cdot\text{K}$  for the range of velocities considered here), and (ii) the average air temperature is reduced, as evident in the graph above.

```
//Geometrical Values
w2 = 0.10 //m
At = 0.070 //m^2
Af = 0.011 //m^2
N = 6
Lc = 0.055 //m
t = 0.010 //m
S = 0.018 //m
Lf = 0.050 //m

//Properties
nuair = 16.4e-6 //m^2/s
Prair = 0.706
kair = 0.027 //W/mK
cpair = 1007 //J/kgK
khs = 180 //W/mK
rhoair = 1.145 //kg/m^3

//Base Thermal Resistance
Rtb = 5.56*10^-3 //K/W

//Driving Temperatures
Tbase = 70 //C
Tinf = 20 //C

//Begin by Guessing the Air Velocity
uair = 2 //m/s

//Convection Coefficient
Dh = 4*Lf*(S - t)/(2*(S - t) + 2*Lf) //m
Re = uair*Dh/nuair
//Apply the Baehr and Stephan correlation of Chapter 8
Gz = (Dh/w2)*Re*Prair
Nuair = (A + B)/C
A = 3.66/(2.264*tanh(Gz^(-1/3))+1.7*Gz^(-2/3))
B = 0.0499*Gz*tanh(1/Gz)
C = tanh(2.432*Prair^(1/6)*Gz^(-1/6))
hbar = Nuair*kair/Dh //W/m^2K

//Fin Resistance
m = sqrt(2*hbar/khs/t) //m^-1
etaf = tanh(m*Lc)/(m*Lc)
Rto = 1/(hbar*At*arg) //K/W
arg = 1-N*(Af/At)*(1-etaf)
UA = 1/(Rtb + Rto) //W/K

//Heat Exchanger Dimensionless Parameters
Cmin = uair*(N-1)*rhoair*cpair*(S - t)*Lf //W/K
NTU = UA/Cmin //W/K
eff = 1 - exp(-NTU)

//Energy Balances
Pelec = eff*Cmin*(Tbase - Tinf) //W
Pelec = Cmin*(Tout - Tinf) //W
```

## PROBLEM 11.92

**KNOWN:** Chip and cooling channel dimensions. Water flow rate and inlet temperature. Temperature of chip at base of channel. Chip thermal conductivity.

**FIND:** Water outlet temperature and chip power.

**SCHEMATIC:**

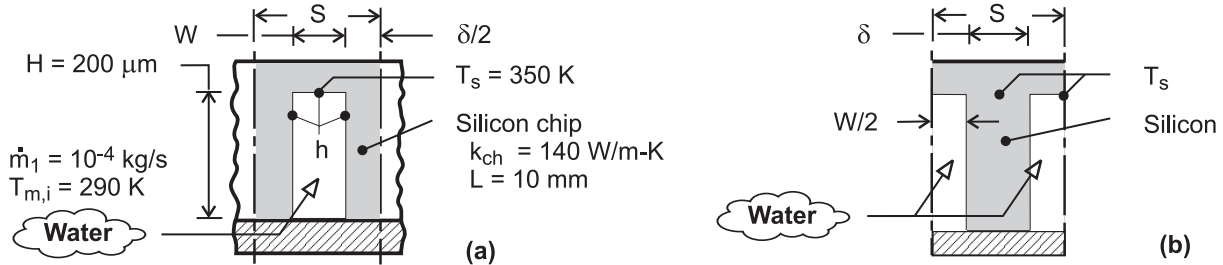

**ASSUMPTIONS:** (1) Incompressible liquid with negligible viscous dissipation, (2) Flow may be approximated as fully developed and channel walls as isothermal for purposes of estimating the convection coefficient, (3) One-dimensional conduction along channel side walls, (4) Adiabatic condition at end of side walls, (5) Heat dissipation is exclusively through fluid flow in channels, (6) Constant properties.

**PROPERTIES:** Table A-6, Water ( $\bar{T}_m = 300\text{K}$ ):  $c_p = 4179\text{ J/kg}\cdot\text{K}$ ,  $\mu = 855 \times 10^{-6}\text{ kg/s}\cdot\text{m}$ ,  $k = 0.613\text{ W/m}\cdot\text{K}$ ,  $Pr = 5.83$ .

**ANALYSIS:** Since the heat sink's bottom surface temperature is spatially uniform, and axial conduction is neglected, the heat sink's thermal behavior corresponds to a single stream heat exchanger. We may use Equation 11.22 to determine the heat transfer rate,

$$q = \varepsilon C_{\min}(T_{h,i} - T_{c,i}) \quad (1)$$

where  $C_{\min} = C_c = \dot{m}_c c_{p,c}$  and  $C_r \rightarrow 0$ . From Section 11.2 and the discussion surrounding Equations 8.45b and 8.46b, we note that the term  $1/UA$  used in the definition of NTU corresponds to the overall thermal resistance between the two fluid streams of a heat exchanger. In this example,  $UA = 1/R_{\text{tot}}$  where  $R_{\text{tot}}$  is the total thermal resistance between the bottom of the heat sink and the fluid. Therefore, Equation 11.35a may be written as

$$\varepsilon = 1 - \exp(-NTU) = 1 - \exp\left(-\frac{UA}{C_{\min}}\right) = 1 - \exp\left(-\frac{1}{R_{\text{tot}} C_{\min}}\right) \quad (2)$$

Once  $C_{\min}$  and  $R_{\text{tot}}$  are evaluated, the effectiveness can be found from Equation 2, and the heat rate may be determined from Equation 1.

**Determination of  $R_{\text{tot}}$ .** The channel sidewalls act as fins, and a *unit* channel/sidewall combination is shown in schematic (a), where the total number of unit cells corresponds to  $N = L/S$ . With  $N = 50$  and  $L = 10\text{ mm}$ ,  $S = 200\text{ }\mu\text{m}$  and  $\delta = S - W = 150\text{ }\mu\text{m}$ . Alternatively, the unit cell may be represented in terms of a single fin of thickness  $\delta$ , as shown in schematic (b). The thermal resistance of the unit cell may be obtained from the expression for a fin array, Eq. (3.108),  $R_{t,o} = (\eta_o h A_t)^{-1}$ , where  $A_t = A_f + A_b = L(2H + W) = 0.01\text{ m}(4 \times 10^{-4} + 0.5 \times 10^{-4})\text{ m} = 4.5 \times 10^{-6}\text{ m}^2$ . With  $D_h = 4(H \times W)/(2(H + W)) = 4(2 \times 10^{-4}\text{ m} \times 0.5 \times 10^{-4}\text{ m})/(2(2.5 \times 10^{-4}\text{ m})) = 8 \times 10^{-5}\text{ m}$ , the Reynolds number is  $Re_D = \rho u_m D_h/\mu = \dot{m}_1 D_h/A_c \mu = 10^{-4}\text{ kg/s} \times 8 \times 10^{-5}\text{ m}/(2 \times 10^{-4}\text{ m} \times 0.5 \times 10^{-4}\text{ m}) 855 \times 10^{-6}\text{ kg/s}\cdot\text{m} = 936$ . Hence, the flow is laminar, and assuming fully developed conditions throughout a channel with uniform surface temperature, Table 8.1 yields  $Nu_D = 4.44$ . Hence,

Continued...

### PROBLEM 11.92 (Cont.)

$$h = \frac{k}{D_h} \text{Nu}_D = \frac{0.613 \text{ W/m}\cdot\text{K} \times 4.44}{8 \times 10^{-5} \text{ m}} = 34,022 \text{ W/m}^2 \cdot \text{K}$$

With  $m = (2h/k_{ch}\delta)^{1/2} = (68,044 \text{ W/m}^2 \cdot \text{K} / 140 \text{ W/m}\cdot\text{K} \times 1.5 \times 10^{-4} \text{ m})^{1/2} = 1800 \text{ m}^{-1}$  and  $mH = 0.36$ , the fin efficiency is

$$\eta_f = \frac{\tanh mH}{mH} = \frac{0.345}{0.36} = 0.958$$

and the overall surface efficiency is

$$\eta_o = 1 - \frac{A_f}{A_t} (1 - \eta_f) = 1 - \frac{4.0 \times 10^{-6}}{4.5 \times 10^{-6}} (1 - 0.958) = 0.963$$

The thermal resistance of the unit cell is then

$$R_{\text{tot}} = (\eta_o h A_t)^{-1} = (0.963 \times 34,022 \text{ W/m}^2 \cdot \text{K} \times 4.5 \times 10^{-6} \text{ m}^2)^{-1} = 6.78 \text{ K/W}$$

*Determination of  $C_{\text{min}}$ .* The minimum heat capacity rate is

$$C_{\text{min}} = \dot{m}_1 c_p = 10^{-4} \text{ kg/s} \times 4179 \text{ J/kg}\cdot\text{K} = 0.4179 \text{ W/K}$$

From Equation 2,

$$\varepsilon = 1 - \exp\left(-\frac{1}{R_{\text{tot}} C_{\text{min}}}\right) = 1 - \exp\left(-\frac{1}{6.78 \text{ K/W} \times 0.4179 \text{ W/K}}\right) = 0.297$$

and from Equation 1, the heat rate per channel is

$$q_1 = \varepsilon C_{\text{min}} (T_h - T_{c,i}) = 0.297 \times 0.4179 \text{ W/K} \times (350 \text{ K} - 290 \text{ K}) = 7.46 \text{ W}$$

and the chip power dissipation is

$$q = Nq_1 = 50 \times 7.46 \text{ W} = 373 \text{ W} \quad <$$

The outlet temperature follows from an energy balance on a channel,

$$q_1 = C_{\text{min}} (T_{m,o} - T_{m,i}), \quad T_{m,o} = T_{m,i} + \frac{q_1}{C_{\text{min}}} = 290 \text{ K} + \frac{7.46 \text{ W}}{0.4179 \text{ W/K}} = 307.8 \text{ K} \quad <$$

**COMMENTS:** (1) With  $L/D_h = 125$  and  $(L/D_h)_{\text{fd}} \approx 0.05 \text{ Re}_D \text{ Pr} = 273$ , fully developed flow is not achieved and the value of  $h = h_{\text{fd}}$  underestimates the actual value of  $\bar{h}$  in the channel. The coefficient is also underestimated by using a Nusselt number that presumes heat transfer from all four (rather than three) surfaces of a channel.

### PROBLEM 11.93

**KNOWN:** Dimensions, particle diameter, and porosity of bronze foam sheet. Temperature of upper and lower surfaces of foam. Velocity and inlet temperature of air flowing through foam.

**FIND:** Convection heat transfer rate to air accounting for both the increase in the air temperature as it flows through the foam and thermal resistance due to conduction in the foam. Whether actual heat transfer rate would be greater, less, or the same.

**SCHEMATIC:**

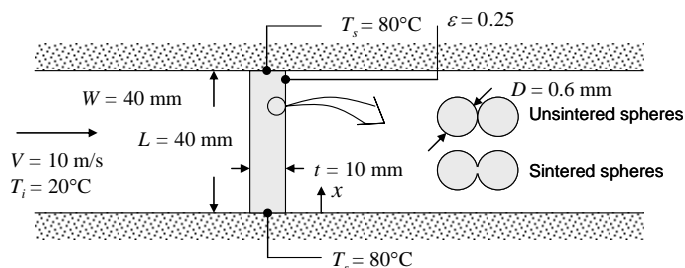

**ASSUMPTIONS:** (1) Steady-state conditions, (2) Constant properties, (3) Heat transfer coefficient between foam and air can be determined from packed bed analysis, (4) Foam behaves as extended surface, (5) Effective thermal conductivity of foam can be found from Maxwell's relation, (6) Negligible radiation transfer.

**PROPERTIES:** Table A-1, Commercial bronze ( $T \approx 325$  K):  $k_b = 52$  W/m·K. Table A-4, Air ( $T \approx 325$  K):  $\rho = 1.0782$  kg/m<sup>3</sup>,  $c_p = 1008$  J/kg·K,  $k = 0.0282$  W/m·K,  $\nu = 18.41 \times 10^{-6}$  m<sup>2</sup>/s,  $Pr = 0.704$ .

**ANALYSIS:** Following Example 11.7, the air flow can be treated as flow through a single stream heat exchanger, exchanging heat with a surface at  $T_s$  through a single fin resistance. Due to symmetry, the foam sheet can be treated as a fin of length  $L/2$  with an insulated fin tip.

Because the fin is foam and the air flows through it, the heat transfer coefficient can be found from the packed bed analysis of Equation 7.81:

$$\varepsilon \bar{j}_H = \varepsilon \frac{\bar{h}}{\rho c_p V} Pr^{2/3} = 2.06 Re_D^{-0.575}$$

where  $Re_D = VD/\nu = 10 \text{ m/s} \times 0.0006 \text{ m} / 18.41 \times 10^{-6} \text{ m}^2/\text{s} = 326$

$$\begin{aligned} \bar{h} &= \frac{2.06 \rho c_p V}{\varepsilon} Re_D^{-0.575} Pr^{-2/3} \\ &= \frac{2.06 \times 1.0782 \text{ kg/m}^3 \times 1008 \text{ J/kg} \cdot \text{K} \times 10 \text{ m/s}}{0.25} (326)^{-0.575} (0.704)^{-2/3} = 4060 \text{ W/m}^2 \cdot \text{K} \end{aligned}$$

The surface area of the sintered particles can be found as follows, where  $N$  = number of particles:

$$\begin{aligned} V_p &= N\pi D^3/6 = (1 - \varepsilon)V_{\text{tot}} = (1 - \varepsilon)WtL \text{ and} \\ A_{p,t} &= N\pi D^2 = 6(1 - \varepsilon)WtL/D = \frac{6 \times 0.75 \times 0.04 \text{ m} \times 0.01 \text{ m} \times 0.04 \text{ m}}{0.0006 \text{ m}} = 0.12 \text{ m}^2 \end{aligned}$$

Continued...

### PROBLEM 11.93 (Cont.)

For a slice of the foam of length  $dx$ , the surface area of foam in contact with the air is  $dA_s = A_{p,t}dx/L$ . Thus,

$$dq_{\text{conv}} = \frac{\bar{h}A_{p,t}dx}{L}(T(x) - T_\infty)$$

By analogy with  $dq_{\text{conv}} = hPdx(T(x) - T_\infty)$  for a solid fin, we find

$$P_{\text{eff}} = \frac{A_{p,t}}{L} = \frac{0.12 \text{ m}^2}{0.04 \text{ m}} = 3.0 \text{ m}$$

From Equation 3.25, with  $k_s = k_b$ ,

$$\begin{aligned} k_{\text{eff}} &= \left[ \frac{k_f + 2k_b - 2\varepsilon(k_b - k_f)}{k_f + 2k_b + \varepsilon(k_b - k_f)} \right] k_b \\ &= \left[ \frac{(0.0282 + 2 \times 52 - 2 \times 0.25 \times (52 - 0.0282)) \text{ W/m} \cdot \text{K}}{(0.0282 + 2 \times 52 + 0.25 \times (52 - 0.0282)) \text{ W/m} \cdot \text{K}} \right] \times 52 \text{ W/m} \cdot \text{K} = 34.7 \text{ W/m} \cdot \text{K} < \end{aligned}$$

The fin efficiency is given by Equation 11.4, where  $A_c$  is the fin cross-sectional area,  $A_c = Wt = 0.04 \text{ m} \times 0.01 \text{ m} = 4 \times 10^{-4} \text{ m}^2$ . We first calculate

$$mL_f = \sqrt{\bar{h}P_{\text{eff}}/k_{\text{eff}}A_c}(L/2) = \sqrt{4060 \text{ W/m}^2 \cdot \text{K} \times 3 \text{ m}/(34.7 \text{ W/m} \cdot \text{K} \times 4 \times 10^{-4} \text{ m}^2)} \times 0.02 \text{ m} = 18.7$$

Then

$$\eta_f = \frac{\tanh(mL_f)}{mL_f} = \frac{\tanh(18.7)}{18.7} = 0.0535$$

The fin is inefficient because it is significantly longer than it needs to be to maximize heat transfer between the air and foam. From Equation 3.97, the fin resistance is

$$R_{t,f} = 1/\bar{h}A_{p,t}\eta_f = 1/(4060 \text{ W/m}^2 \cdot \text{K} \times 0.12 \text{ m}^2 \times 0.0535) = 0.0384 \text{ K/W}$$

Note that the fin surface area is  $A_{p,t}$ , since this is the area for heat transfer between the foam and air. Following the approach in Example 11.7,

$$\begin{aligned} C_{\text{min}} &= \dot{m}_c c_{p,c} = \rho V A_{c,b} c_p \\ &= 1.0782 \text{ kg/m}^3 \times 10 \text{ m/s} \times (0.04 \text{ m})^2 \times 1008 \text{ J/kg} \cdot \text{K} = 17.4 \text{ W/K} \end{aligned}$$

Continued...



### PROBLEM 11.93 (Cont.)

$$\varepsilon = 1 - \exp(-NTU) = 1 - \exp\left(-\frac{1}{R_{t,f} C_{\min}}\right) = 1 - \exp\left(-\frac{1}{0.0384 \text{ K/W} \times 17.4 \text{ W/K}}\right) = 0.776$$

Finally,

$$q = \varepsilon C_{\min}(T_s - T_{c,i}) = 0.776 \times 17.4 \text{ W/K} \times (80^\circ\text{C} - 20^\circ\text{C}) = 810 \text{ W} \quad <$$

This is probably close to the correct answer, although temperature gradients in the streamwise direction in the foam are not accounted for. The actual value would therefore be less than 810 W. <

**COMMENTS:** The solution to Problem 7.113 was achieved in two ways: (a) assuming the foam temperature is uniform at  $T_s$  and accounting for the variation of air temperature in the flow direction, and (b) assuming the air temperature is uniform at  $T_i$  and accounting for the variation of foam temperature in the  $x$ -direction. Both of these approaches significantly overestimate the actual heat transfer rate.

## PROBLEM 11.94

**KNOWN:** Dimensions, particle diameter, and porosity of bronze foam heat sink attached to silicon chip. Chip temperature. Velocity and inlet temperature of air flowing through foam.

**FIND:** Heat transfer rate from chip.

**SCHEMATIC:**

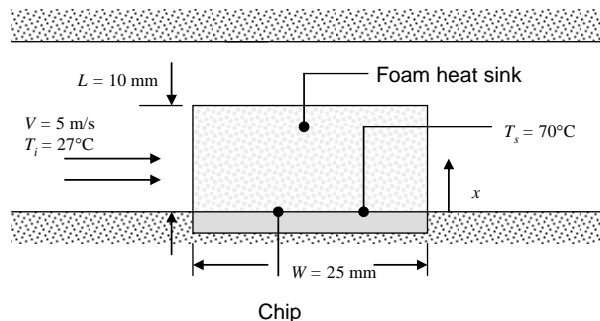

**ASSUMPTIONS:** (1) Steady-state, (2) Constant properties, (3) Heat transfer coefficient between foam and air can be determined from packed bed analysis, (4) Foam behaves as extended surface, (5) Effective thermal conductivity of foam can be found from Maxwell's relation, (6) Air flows uniformly through foam rather than being diverted toward open region above heat sink, (7) Negligible radiation transfer.

**PROPERTIES:** Table A-1, Commercial bronze ( $T \approx 323$  K):  $k_b = 52$  W/m·K. Table A-4, Air ( $T \approx 325$  K):  $\rho_a = 1.0782$  kg/m<sup>3</sup>,  $c_{p,a} = 1008$  J/kg·K,  $k_a = 0.0282$  W/m·K,  $\nu_a = 18.41 \times 10^{-6}$  m<sup>2</sup>/s,  $Pr = 0.704$ .

**ANALYSIS:** Following Example 11.7, the air flow can be treated as flow through a single stream heat exchanger, exchanging heat with a surface at  $T_s$  through a single fin resistance. Because the fin is foam and the air flows through it, the heat transfer coefficient can be found from the packed bed analysis of Equation 7.81:

$$\varepsilon \bar{j}_H = \varepsilon \frac{\bar{h}}{\rho c_p V} Pr^{2/3} = 2.06 Re_D^{-0.575}$$

where  $Re_D = VD/\nu = 5 \text{ m/s} \times 0.0006 \text{ m} / 18.41 \times 10^{-6} \text{ m}^2/\text{s} = 163$

$$\begin{aligned} \bar{h} &= \frac{2.06 \rho c_p V}{\varepsilon} Re_D^{-0.575} Pr^{-2/3} \\ &= \frac{2.06 \times 1.0782 \text{ kg/m}^3 \times 1008 \text{ J/kg} \cdot \text{K} \times 5 \text{ m/s}}{0.25} (163)^{-0.575} (0.704)^{-2/3} = 3030 \text{ W/m}^2 \cdot \text{K} \end{aligned}$$

The surface area of the sintered particles can be found as follows, where  $N$  = number of particles:

$$\begin{aligned} V_p &= N\pi D^3/6 = (1 - \varepsilon)V_{\text{tot}} = (1 - \varepsilon)W^2L \text{ and} \\ A_{p,t} &= N\pi D^2 = 6(1 - \varepsilon)W^2L/D = \frac{6 \times 0.75 \times (0.025 \text{ m})^2 \times 0.01 \text{ m}}{0.0006 \text{ m}} = 0.0469 \text{ m}^2 \end{aligned}$$

Continued...

### PROBLEM 11.94 (Cont.)

For a slice of the foam of length  $dx$ , the surface area of foam in contact with the air is  $dA_s = A_{p,t} dx/L$ . Thus,

$$dq_{\text{conv}} = \frac{\bar{h}A_{p,t} dx}{L} (T(x) - T_\infty)$$

By analogy with  $dq_{\text{conv}} = hPdx(T(x) - T_\infty)$  for a solid fin, we find

$$P_{\text{eff}} = \frac{A_{p,t}}{L} = \frac{0.0469 \text{ m}^2}{0.01 \text{ m}} = 4.69 \text{ m}$$

From Equation 3.25, with  $k_s = k_b$ ,

$$\begin{aligned} k_{\text{eff}} &= \left[ \frac{k_f + 2k_b - 2\varepsilon(k_b - k_f)}{k_f + 2k_b + \varepsilon(k_b - k_f)} \right] k_b \\ &= \left[ \frac{(0.0282 + 2 \times 52 - 2 \times 0.25 \times (52 - 0.0282)) \text{ W/m} \cdot \text{K}}{(0.0282 + 2 \times 52 + 0.25 \times (52 - 0.0282)) \text{ W/m} \cdot \text{K}} \right] \times 52 \text{ W/m} \cdot \text{K} = 34.7 \text{ W/m} \cdot \text{K} \end{aligned}$$

The fin efficiency is given by Equation 11.4, where  $A_c$  is the fin cross-sectional area,  $A_c = W^2 = (0.025 \text{ m})^2 = 6.25 \times 10^{-4} \text{ m}^2$ . We first calculate

$$mL = \sqrt{\bar{h}P_{\text{eff}} / k_{\text{eff}} A_c} L = \sqrt{3030 \text{ W/m}^2 \cdot \text{K} \times 4.69 \text{ m} / (34.7 \text{ W/m} \cdot \text{K} \times 6.25 \times 10^{-4} \text{ m}^2)} \times 0.01 \text{ m} = 8.09$$

Then

$$\eta_f = \frac{\tanh(mL_f)}{mL_f} = \frac{\tanh(8.09)}{8.09} = 0.124$$

From Equation 3.97, the fin resistance is

$$R_{t,f} = 1 / \bar{h}A_{p,t}\eta_f = 1 / (3030 \text{ W/m}^2 \cdot \text{K} \times 0.0469 \text{ m}^2 \times 0.124) = 0.0570 \text{ K/W}$$

Note that the fin surface area is  $A_{p,t}$ , since this is the area for heat transfer between the foam and air. Following the approach in Example 11.7,

$$\begin{aligned} C_{\text{min}} &= \dot{m}_c c_{p,c} = \rho V A_{c,b} c_p \\ &= 1.0782 \text{ kg/m}^3 \times 5 \text{ m/s} \times 0.01 \text{ m} \times 0.025 \text{ m} \times 1008 \text{ J/kg} \cdot \text{K} = 1.36 \text{ W/K} \end{aligned}$$

Continued...

**PROBLEM 11.94 (Cont.)**

$$\varepsilon = 1 - \exp(-NTU) = 1 - \exp\left(-\frac{1}{R_{t,f} C_{\min}}\right) = 1 - \exp\left(-\frac{1}{0.0570 \text{ K/W} \times 1.36 \text{ W/K}}\right) = 1.0$$

Finally,

$$q = \varepsilon C_{\min}(T_s - T_{c,i}) = 1.0 \times 1.36 \text{ W/K} \times (70^\circ\text{C} - 27^\circ\text{C}) = 58.4 \text{ W} \quad <$$

**COMMENTS:** (1) With a fin efficiency of unity, the foam temperature is essentially uniform at  $T_s$ , and the heat transfer rate is identical to that which would be found from a packed bed analysis that ignored the conduction resistance in the foam. This is an indication that the heat sink design could be improved to reduce its weight without significantly sacrificing performance. (2) The heat sink poses a resistance to air flow, and much of the air would be diverted around the foam block toward the open area above it, reducing its performance. The design could be altered to inhibit diversion of the air to the open region.

## PROBLEM 12.1

**KNOWN:** Opaque, horizontal plate, well insulated on backside, is subjected to a prescribed irradiation. Also known are the reflected irradiation, emissive power, plate temperature and convection coefficient for known air temperature.

**FIND:** (a) Emissivity, absorptivity and radiosity and (b) Net heat transfer per unit area of the plate.

**SCHEMATIC:**

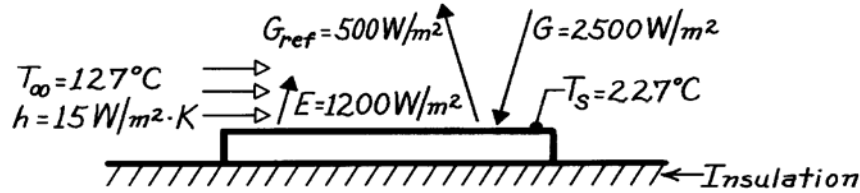

**ASSUMPTIONS:** (1) Plate is insulated on backside, (2) Plate is opaque.

**ANALYSIS:** (a) The emissivity of the plate according to Table 12.1 is

$$\varepsilon = \frac{E}{E_b(T_s)} = \frac{E}{\sigma T_s^4} = \frac{1200 \text{ W/m}^2}{5.67 \times 10^{-8} \text{ W/m}^2 \cdot \text{K}^4 \times (227 + 273)^4 \text{ K}^4} = 0.34. \quad <$$

The absorptivity is related to the reflectivity by Eq. 12.3 for an opaque surface. That is,  $\alpha = 1 - \rho$ . By definition, the reflectivity is the fraction of irradiation reflected, such that

$$\alpha = 1 - G_{\text{ref}} / G = 1 - 500 \text{ W/m}^2 / (2500 \text{ W/m}^2) = 1 - 0.20 = 0.80. \quad <$$

The radiosity,  $J$ , is defined as the radiant flux leaving the surface by emission and reflection per unit area of the surface (Eq. 12.4).

$$J = \rho G + \varepsilon E_b = G_{\text{ref}} + E = 500 \text{ W/m}^2 + 1200 \text{ W/m}^2 = 1700 \text{ W/m}^2. \quad <$$

(b) The net heat transfer to the surface is determined from an energy balance,

$$q''_{\text{net}} = q''_{\text{in}} - q''_{\text{out}} = G - G_{\text{ref}} - E - q''_{\text{conv}}$$

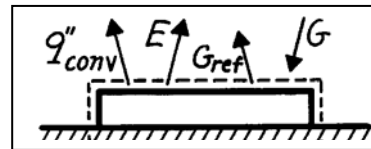

$$q''_{\text{net}} = (2500 - 500 - 1200) \text{ W/m}^2 - 15 \text{ W/m}^2 \cdot \text{K} (227 - 127) \text{ K} = -700 \text{ W/m}^2. \quad <$$

An alternate approach to the energy balance using the radiosity, Eq. 12.5,

$$q''_{\text{net}} = G - J - q''_{\text{conv}}$$

$$q''_{\text{net}} = (2500 - 1700 - 1500) \text{ W/m}^2$$

$$q''_{\text{net}} = -700 \text{ W/m}^2.$$

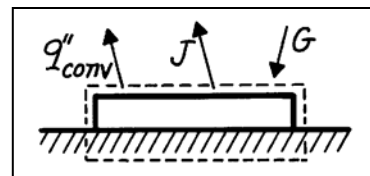

**COMMENTS:** (1) Since the net heat rate per unit area is negative, energy must be added to the plate in order to maintain it at  $T_s = 227^\circ\text{C}$ . (2) Note that  $\alpha \neq \varepsilon$ . Hence, the plate is not a gray surface, as described in Section 1.2.3. (3) Note the use of radiosity in performing energy balances. That is, considering only the radiation processes,  $q''_{\text{net}} = G - J$ .

## PROBLEM 12.2

**KNOWN:** Horizontal, opaque surface at steady-state temperature of  $77^\circ\text{C}$  is exposed to a convection process; emissive power, irradiation and reflectivity are prescribed.

**FIND:** (a) Absorptivity of the surface, (b) Net radiation heat transfer rate for the surface; indicate direction, (c) Total heat transfer rate for the surface; indicate direction.

**SCHEMATIC:**

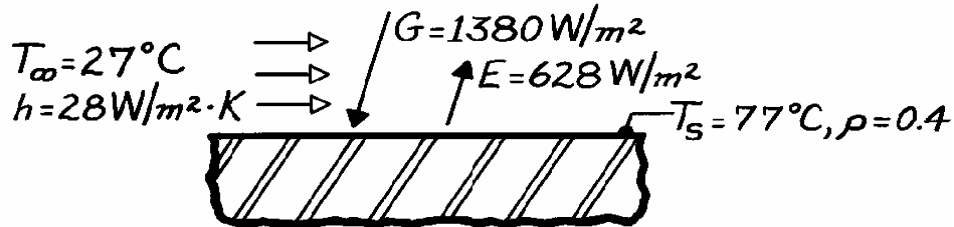

**ASSUMPTIONS:** (1) Surface is opaque, (2) Effect of surroundings included in the specified irradiation, (3) Steady-state conditions.

**ANALYSIS:** (a) From the definition of the thermal radiative properties and a radiation balance for an opaque surface, according to Eq. 12.3,

$$\alpha = 1 - \rho = 1 - 0.4 = 0.6.$$

(b) The net radiation heat transfer rate from the surface is

$$q''_{\text{rad}} = E + \rho G - G = (628 + 0.4 \times 1380 - 1380) \text{ W/m}^2 = -200 \text{ W/m}^2.$$

Since  $q''_{\text{rad}}$  is negative, the net radiation heat transfer rate is *to* the surface.

(c) Performing a surface energy balance considering all heat transfer processes, the local heat transfer rate is

$$q''_{\text{tot}} = q''_{\text{rad}} + q''_{\text{conv}}$$

$$q''_{\text{tot}} = -200 \text{ W/m}^2 + 28 \text{ W/m}^2 \cdot \text{K} (77 - 27) \text{ K} = 1200 \text{ W/m}^2.$$

The total heat flux is shown as a positive value indicating the heat flux is *from* the surface.

**COMMENTS:** (1) Note that the surface radiation balance could also be expressed as

$$q''_{\text{rad}} = J - G \quad \text{or} \quad E - \alpha G.$$

Note the use of radiosity to express the radiation flux leaving the surface.

(2) From knowledge of the surface emissive power and  $T_s$ , find the emissivity as

$$\varepsilon \equiv E / \sigma T_s^4 = 628 \text{ W/m}^2 / (5.67 \times 10^{-8} \text{ W/m}^2 \cdot \text{K}^4) (77 + 273)^4 \text{ K}^4 = 0.74.$$

COMMENT: Since  $\varepsilon \neq \alpha$ , we know the surface is not gray, as discussed in Section 1.2.3.

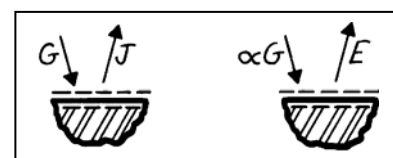
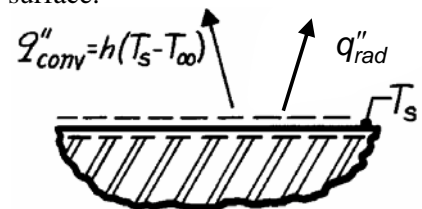
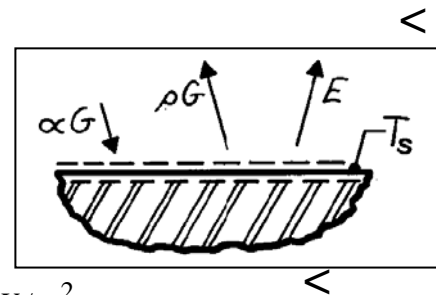

### PROBLEM 12.3

**KNOWN:** Thickness and temperature of aluminum plate. Irradiation. Convection conditions. Absorptivity and emissivity.

**FIND:** Radiosity and net radiation heat flux at top plate surface, rate of change of plate temperature.

**SCHEMATIC:**

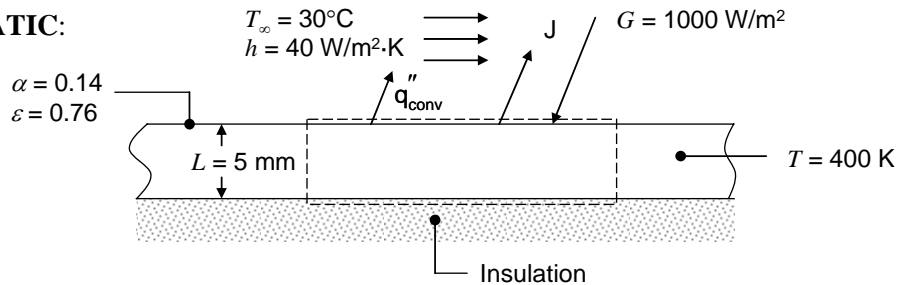

**ASSUMPTIONS:** (1) Plate temperature is uniform, (2) Plate is opaque,  $\tau = 0$ .

**PROPERTIES:** Table A-1, Pure aluminum ( $T = 400$  K):  $\rho = 2702$  kg/m<sup>3</sup>,  $c = 949$  J/kg·K.

**ANALYSIS:** The radiosity is equal to the sum of emitted and reflected radiation:

$$\begin{aligned} J &= \rho G + \varepsilon E_b = (1 - \alpha)G + \varepsilon \sigma T^4 \\ &= (1 - 0.14) \times 1000 \text{ W/m}^2 + 0.76 \times 5.67 \times 10^{-8} \text{ W/m}^2 \cdot \text{K}^4 \times (400 \text{ K})^4 \\ &= 1963 \text{ W/m}^2 \end{aligned} \quad <$$

The net radiation heat flux from the plate is equal to the radiosity minus the irradiation:

$$q''_{\text{rad}} = J - G = 1963 \text{ W/m}^2 - 1000 \text{ W/m}^2 = 963 \text{ W/m}^2 \quad <$$

The rate of change of the plate temperature can be found from an energy balance on the plate, accounting for heat loss by both radiation and convection,

$$\begin{aligned} \frac{dT}{dt} &= -\frac{q_{\text{conv}} + q_{\text{rad}}}{\rho c V} = -\frac{q''_{\text{conv}} + q''_{\text{rad}}}{\rho c L} = -\frac{h(T - T_{\infty}) + q''_{\text{rad}}}{\rho c L} \\ &= -\frac{40 \text{ W/m}^2 \cdot \text{K} \times (400 \text{ K} - (30 + 273) \text{ K}) + 963 \text{ W/m}^2}{2702 \text{ kg/m}^3 \times 949 \text{ J/kg} \cdot \text{K} \times 0.005 \text{ m}} = -0.378 \text{ K/s} \end{aligned} \quad <$$

**COMMENTS:** (1) The values given for absorptivity and emissivity correspond to solar irradiation and room temperature emission for anodized aluminum. (2) The surroundings temperature is not needed for this solution since the irradiation value is given.

## PROBLEM 12.4

**KNOWN:** Temperature, absorptivity, transmissivity, radiosity and convection conditions for a semitransparent plate.

**FIND:** Plate irradiation and total hemispherical emissivity.

**SCHEMATIC:**

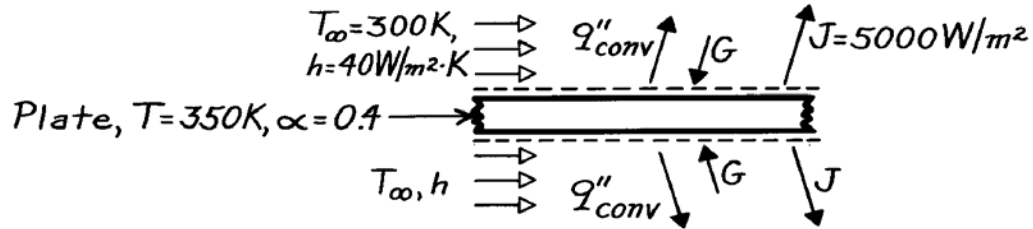

**ASSUMPTIONS:** (1) Steady-state conditions, (2) Uniform surface conditions.

**ANALYSIS:** From an energy balance on the plate

$$\dot{E}_{\text{in}} = \dot{E}_{\text{out}}$$

$$2G = 2q''_{\text{conv}} + 2J.$$

Solving for the irradiation and substituting numerical values,

$$G = 40 \text{ W/m}^2 \cdot \text{K} (350 - 300) \text{ K} + 5000 \text{ W/m}^2 = 7000 \text{ W/m}^2. \quad <$$

From the definition of the radiosity J,

$$J = E + \rho G + \tau G = E + (1 - \alpha)G.$$

Solving for the emissivity and substituting numerical values,

$$\varepsilon = \frac{J - (1 - \alpha)G}{\sigma T^4} = \frac{(5000 \text{ W/m}^2) - 0.6(7000 \text{ W/m}^2)}{5.67 \times 10^{-8} \text{ W/m}^2 \cdot \text{K}^4 (350 \text{ K})^4} = 0.94. \quad <$$

Hence,

$$\alpha \neq \varepsilon$$

and the surface is not gray for the prescribed conditions.

**COMMENTS:** The emissivity may also be determined by expressing the plate energy balance as

$$2\alpha G = 2q''_{\text{conv}} + 2E.$$

Hence

$$\varepsilon \sigma T^4 = \alpha G - h(T - T_{\infty})$$

$$\varepsilon = \frac{0.4(7000 \text{ W/m}^2) - 40 \text{ W/m}^2 \cdot \text{K} (50 \text{ K})}{5.67 \times 10^{-8} \text{ W/m}^2 \cdot \text{K}^4 (350 \text{ K})^4} = 0.94.$$



## PROBLEM 12.5

**KNOWN:** Rate at which radiation is intercepted by each of three surfaces (see Example 12.1).

**FIND:** Irradiation,  $G$  [ $\text{W}/\text{m}^2$ ], at each of the three surfaces.

**SCHEMATIC:**

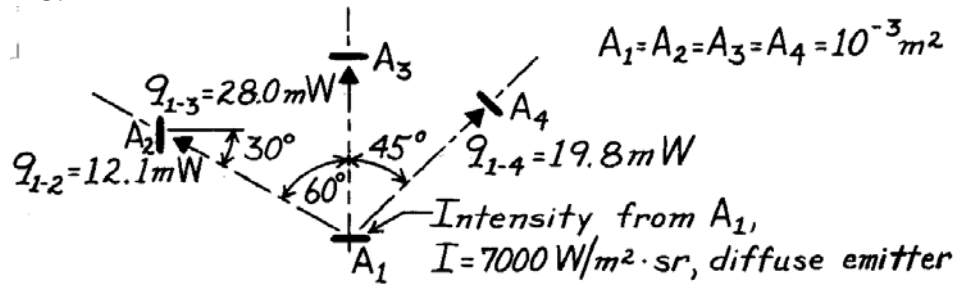

**ANALYSIS:** The irradiation at a surface is the rate at which radiation is incident on a surface per unit area of the surface. The irradiation at surface  $j$  due to emission from surface 1 is

$$G_j = \frac{q_{1-j}}{A_j}$$

With  $A_1 = A_2 = A_3 = A_4 = 10^{-3} \text{ m}^2$  and the incident radiation rates  $q_{1-j}$  from the results of Example 12.1, find

$$G_2 = \frac{12.1 \times 10^{-3} \text{ W}}{10^{-3} \text{ m}^2} = 12.1 \text{ W}/\text{m}^2 \quad <$$

$$G_3 = \frac{28.0 \times 10^{-3} \text{ W}}{10^{-3} \text{ m}^2} = 28.0 \text{ W}/\text{m}^2 \quad <$$

$$G_4 = \frac{19.8 \times 10^{-3} \text{ W}}{10^{-3} \text{ m}^2} = 19.8 \text{ W}/\text{m}^2. \quad <$$

**COMMENTS:** The irradiation could also be computed from Eq. 12.18, which, for the present situation, takes the form

$$G_j = I_1 \cos \theta_j \omega_{1-j}$$

where  $I_1 = I = 7000 \text{ W}/\text{m}^2 \cdot \text{sr}$  and  $\omega_{1-j}$  is the solid angle subtended by surface 1 with respect to  $j$ . For example,

$$G_2 = I_1 \cos \theta_2 \omega_{1-2}$$

$$G_2 = 7000 \text{ W}/\text{m}^2 \cdot \text{sr} \times$$

$$\cos 30^\circ \frac{10^{-3} \text{ m}^2 \times \cos 60^\circ}{(0.5 \text{ m})^2}$$

$$G_2 = 12.1 \text{ W}/\text{m}^2.$$

Note that, since  $A_1$  is a diffuse radiator, the intensity  $I$  is independent of direction.

## PROBLEM 12.6

**KNOWN:** A diffuse surface of area  $A_1 = 10^{-4} \text{ m}^2$  emits diffusely with total emissive power  $E = 5 \times 10^4 \text{ W/m}^2$ .

**FIND:** (a) Rate this emission is intercepted by small surface of area  $A_2 = 5 \times 10^{-4} \text{ m}^2$  at a prescribed location and orientation, (b) Irradiation  $G_2$  on  $A_2$ , and (c) Compute and plot  $G_2$  as a function of the separation distance  $r_2$  for the range  $0.25 \leq r_2 \leq 1.0 \text{ m}$  for zenith angles  $\theta_2 = 0, 30$  and  $60^\circ$ .

**SCHEMATIC:**

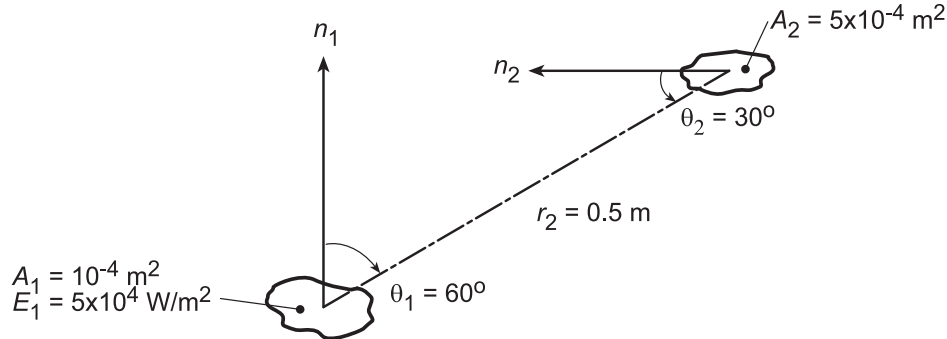

**ASSUMPTIONS:** (1) Surface  $A_1$  emits diffusely, (2)  $A_1$  may be approximated as a differential surface area and that  $A_2/r_2^2 \ll 1$ .

**ANALYSIS:** (a) The rate at which emission from  $A_1$  is intercepted by  $A_2$  follows from Eq. 12.11 written on a total rather than spectral basis.

$$q_{1 \rightarrow 2} = I_{e,1}(\theta, \phi) A_1 \cos \theta_1 d\omega_{2-1}. \quad (1)$$

Since the surface  $A_1$  is diffuse, it follows from Eq. 12.16 that

$$I_{e,1}(\theta, \phi) = I_{e,1} = E_1/\pi. \quad (2)$$

The solid angle subtended by  $A_2$  with respect to  $A_1$  is

$$d\omega_{2-1} \approx A_2 \cos \theta_2 / r_2^2. \quad (3)$$

Substituting Eqs. (2) and (3) into Eq. (1) with numerical values gives

$$q_{1 \rightarrow 2} = \frac{E_1}{\pi} \cdot A_1 \cos \theta_1 \cdot \frac{A_2 \cos \theta_2}{r_2^2} = \frac{5 \times 10^4 \text{ W/m}^2}{\pi \text{ sr}} \times (10^{-4} \text{ m}^2 \times \cos 60^\circ) \times \left[ \frac{5 \times 10^{-4} \text{ m}^2 \times \cos 30^\circ}{(0.5 \text{ m})^2} \right] \text{ sr} \quad (4)$$

$$q_{1 \rightarrow 2} = 15,915 \text{ W/m}^2 \text{ sr} \times (5 \times 10^{-5} \text{ m}^2) \times 1.732 \times 10^{-3} \text{ sr} = 1.378 \times 10^{-3} \text{ W}. \quad <$$

(b) From section 12.3.3, the irradiation is the rate at which radiation is incident upon the surface per unit surface area,

$$G_2 = \frac{q_{1 \rightarrow 2}}{A_2} = \frac{1.378 \times 10^{-3} \text{ W}}{5 \times 10^{-4} \text{ m}^2} = 2.76 \text{ W/m}^2 \quad (5) <$$

(c) Using the IHT workspace with the foregoing equations, the  $G_2$  was computed as a function of the separation distance for selected zenith angles. The results are plotted below.

Continued...

### PROBLEM 12.6 (Cont.)

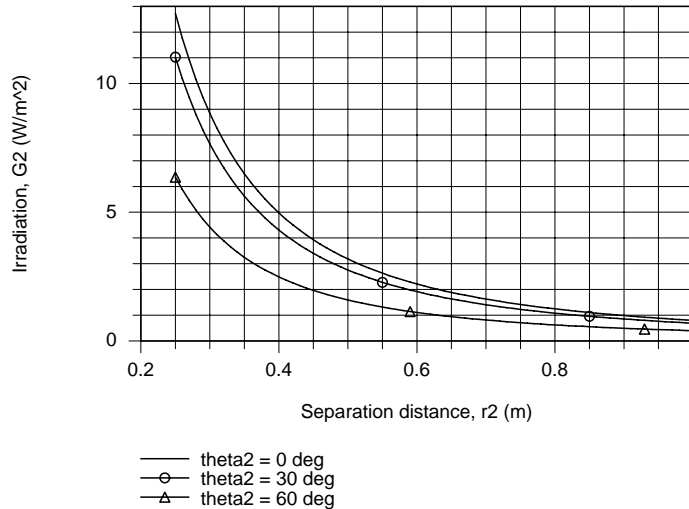

For all zenith angles,  $G_2$  decreases with increasing separation distance  $r_2$ . From Eq. (3), note that  $d\omega_{2-1}$  and, hence  $G_2$ , vary inversely as the square of the separation distance. For any fixed separation distance,  $G_2$  is a maximum when  $\theta_2 = 0^\circ$  and decreases with increasing  $\theta_2$ , proportional to  $\cos \theta_2$ .

**COMMENTS:** (1) For a diffuse surface, the intensity,  $I_e$ , is independent of direction and related to the emissive power as  $I_e = E/\pi$ . Note that  $\pi$  has the units of [sr] in this relation.

(2) Note that Eq. 12.12 is an important relation for determining the radiant power leaving a surface in a prescribed manner. It has been used here on a total rather than spectral basis.

(3) Returning to part (b) and referring to Figure 12.10, the irradiation on  $A_2$  may be expressed as

$$G_2 = I_{1,2} \cos \theta_2 \frac{A_1 \cos \theta_1}{r_2^2}$$

Show that the result is  $G_2 = 2.76 \text{ W/m}^2$ . Explain how this expression follows from Eq. 12.18.

## PROBLEM 12.7

**KNOWN:** Furnace with prescribed aperture and emissive power.

**FIND:** (a) Position of gauge such that irradiation is  $G = 1000 \text{ W/m}^2$ , (b) Irradiation when gauge is tilted  $\theta_d = 20^\circ$ , and (c) Compute and plot the gage irradiation,  $G$ , as a function of the separation distance,  $L$ , for the range  $100 \leq L \leq 300 \text{ mm}$  and tilt angles of  $\theta_d = 0, 20$ , and  $60^\circ$ .

**SCHEMATIC:**

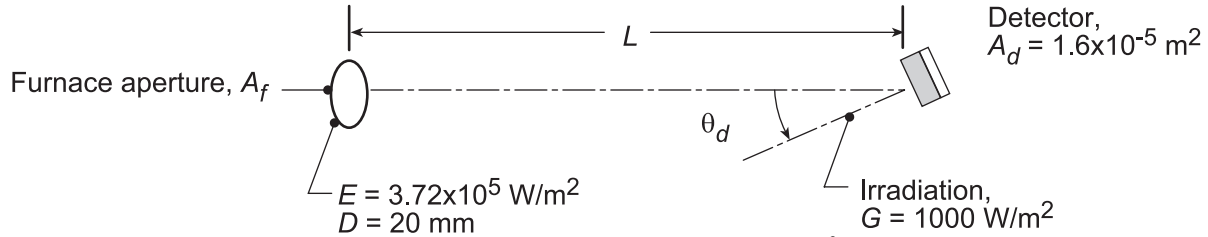

**ASSUMPTIONS:** (1) Furnace aperture emits diffusely, (2)  $A_d \ll L^2$ .

**ANALYSIS:** (a) The irradiation on the detector area is defined as the power incident on the surface per unit area of the surface. That is

$$G = q_{f \rightarrow d} / A_d \quad q_{f \rightarrow d} = I_e A_f \cos \theta_f \omega_{d-f} \quad (1,2)$$

where  $q_{f \rightarrow d}$  is the radiant power which leaves  $A_f$  and is intercepted by  $A_d$ . From Eqs. 12.7 and 12.12,

$\omega_{d-f}$  is the solid angle subtended by surface  $A_d$  with respect to  $A_f$ ,

$$\omega_{d-f} = A_d \cos \theta_d / L^2. \quad (3)$$

Noting that since the aperture emits diffusely,  $I_e = E/\pi$  (see Eq. 12.17), and hence

$$G = (E/\pi) A_f \cos \theta_f \left( A_d \cos \theta_d / L^2 \right) / A_d \quad (4)$$

Solving for  $L^2$  and substituting for the condition  $\theta_f = 0^\circ$  and  $\theta_d = 0^\circ$ ,

$$L^2 = E \cos \theta_f \cos \theta_d A_f / \pi G. \quad (5)$$

$$L = \left[ 3.72 \times 10^5 \text{ W/m}^2 \times \frac{\pi}{4} (20 \times 10^{-3})^2 \text{ m}^2 / \pi \times 1000 \text{ W/m}^2 \right]^{1/2} = 193 \text{ mm}. \quad \leftarrow$$

(b) When  $\theta_d = 20^\circ$ ,  $q_{f \rightarrow d}$  will be reduced by a factor of  $\cos \theta_d$  since  $\omega_{d-f}$  is reduced by a factor  $\cos \theta_d$ . Hence,

$$G = 1000 \text{ W/m}^2 \times \cos \theta_d = 1000 \text{ W/m}^2 \times \cos 20^\circ = 940 \text{ W/m}^2. \quad \leftarrow$$

(c) Using the IHT workspace with Eq. (4),  $G$  is computed and plotted as a function of  $L$  for selected  $\theta_d$ . Note that  $G$  decreases inversely as  $L^2$ . As expected,  $G$  decreases with increasing  $\theta_d$  and in the limit, approaches zero as  $\theta_d$  approaches  $90^\circ$ .

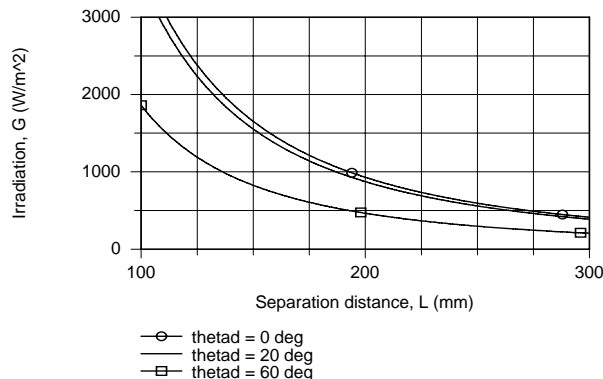

### PROBLEM 12.8

**KNOWN:** Radiation from a diffuse radiant source  $A_1$  with intensity  $I_1 = 1.2 \times 10^5 \text{ W/m}^2 \cdot \text{sr}$  is incident on a mirror  $A_m$ , which reflects radiation onto the radiation detector  $A_2$ .

**FIND:** (a) Radiant power incident on  $A_m$  due to emission from the source,  $A_1$ ,  $q_{1 \rightarrow m}$  (mW), (b) Intensity of radiant power leaving the perfectly reflecting, diffuse mirror  $A_m$ ,  $I_m$  ( $\text{W/m}^2 \cdot \text{sr}$ ), and (c) Radiant power incident on the detector  $A_2$  due to the reflected radiation leaving  $A_m$ ,  $q_{m \rightarrow 2}$  ( $\mu\text{W}$ ), (d) Plot the radiant power  $q_{m \rightarrow 2}$  as a function of the lateral separation distance  $y_o$  for the range  $0 \leq y_o \leq 0.2 \text{ m}$ ; explain features of the resulting curve.

**SCHEMATIC:**

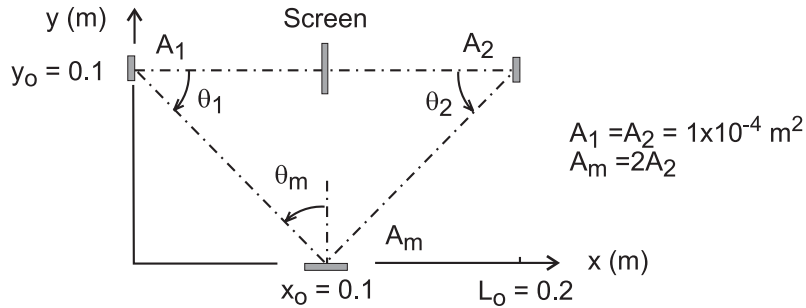

**ASSUMPTIONS:** (1) Surface  $A_1$  emits diffusely, (2) Surface  $A_m$  does not emit, but reflects perfectly and diffusely, and (3) Surface areas are much smaller than the square of their separation distances.

**ANALYSIS:** (a) The radiant power leaving  $A_1$  that is incident on  $A_m$  is

$$q_{1 \rightarrow m} = I_1 \cdot A_1 \cdot \cos \theta_1 \cdot \Delta \omega_{m-1}$$

where  $\omega_{m-1}$  is the solid angle  $A_m$  subtends with respect to  $A_1$ , Eq. 12.7,

$$\Delta \omega_{m-1} \equiv \frac{dA_n}{r^2} = \frac{A_m \cos \theta_m}{x_o^2 + y_o^2} = \frac{2 \times 10^{-4} \text{ m}^2 \cdot \cos 45^\circ}{[0.1^2 + 0.1^2] \text{ m}^2} = 7.07 \times 10^{-3} \text{ sr}$$

with  $\theta_m = 90^\circ - \theta_1$  and  $\theta_1 = 45^\circ$ ,

$$q_{1 \rightarrow m} = 1.2 \times 10^5 \text{ W/m}^2 \cdot \text{sr} \times 1 \times 10^{-4} \text{ m}^2 \times \cos 45^\circ \times 7.07 \times 10^{-3} \text{ sr} = 60 \text{ mW} \quad <$$

(b) The intensity of radiation leaving  $A_m$ , after perfect and diffuse reflection, is

$$I_m = (q_{1 \rightarrow m} / A_m) / \pi = \frac{60 \times 10^{-3} \text{ W}}{\pi \times 2 \times 10^{-4} \text{ m}^2} = 95.5 \text{ W/m}^2 \cdot \text{sr}$$

(c) The radiant power leaving  $A_m$  due to reflected radiation leaving  $A_m$  is

$$q_{m \rightarrow 2} = q_2 = I_m \cdot A_m \cdot \cos \theta_m \cdot \Delta \omega_{2-m}$$

where  $\Delta \omega_{2-m}$  is the solid angle that  $A_2$  subtends with respect to  $A_m$ , Eq. 12.7,

Continued ...

**PROBLEM 12.8 (Cont.)**

$$\Delta\omega_{2-m} \equiv \frac{dA_n}{r^2} = \frac{A_2 \cos \theta_2}{(L_o - x_o)^2 + y_o^2} = \frac{1 \times 10^{-4} \text{ m}^2 \times \cos 45^\circ}{\left[0.1^2 + 0.1^2\right] \text{ m}^2} = 3.54 \times 10^{-3} \text{ sr}$$

with  $\theta_2 = 90^\circ - \theta_m$

$$q_{m \rightarrow 2} = q_2 = 95.5 \text{ W/m}^2 \cdot \text{sr} \times 2 \times 10^{-4} \text{ m}^2 \times \cos 45^\circ \times 3.54 \times 10^{-3} \text{ sr} = 47.8 \text{ } \mu\text{W} \quad <$$

(d) Using the foregoing equations in the *IHT* workspace,  $q_2$  is calculated and plotted as a function of  $y_o$  for the range  $0 \leq y_o \leq 0.2$  m.

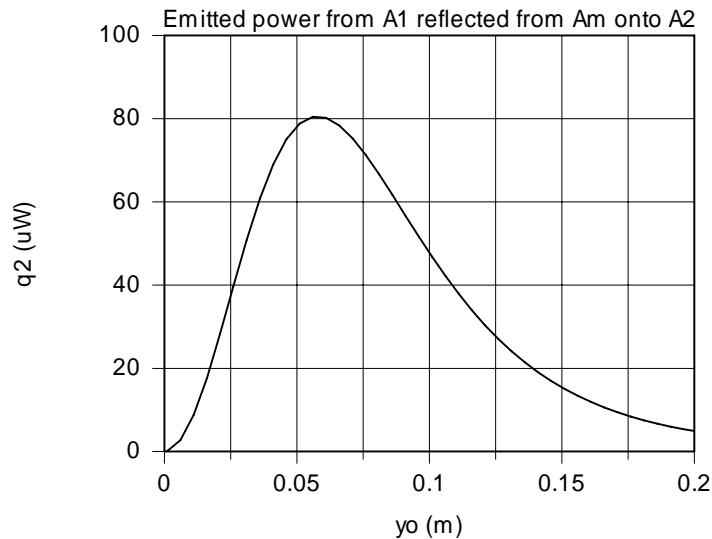

From the relations, note that  $q_2$  is dependent upon the geometric arrangement of the surfaces in the following manner. For small values of  $y_o$ , that is, when  $\theta_1 \approx 0^\circ$ , the  $\cos \theta_1$  term is at a maximum, near unity. But, the solid angles  $\Delta\omega_{m-1}$  and  $\Delta\omega_{2-m}$  are very small. As  $y_o$  increases, the  $\cos \theta_1$  term doesn't diminish as much as the solid angles increase, causing  $q_2$  to increase. A maximum in the power is reached as the  $\cos \theta_1$  term decreases and the solid angles increase. The maximum radiant power occurs when  $y_o = 0.058$  m which corresponds to  $\theta_1 = 30^\circ$ .

### PROBLEM 12.9

**KNOWN:** Flux and intensity of direct and diffuse components, respectively, of solar irradiation.

**FIND:** Total irradiation.

**SCHEMATIC:**

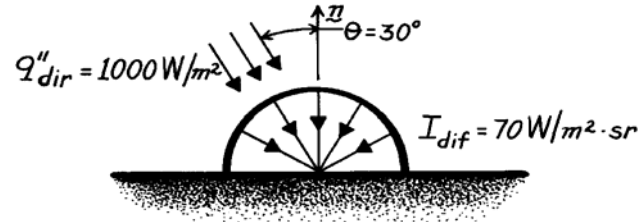

**ANALYSIS:** Since the irradiation is based on the actual surface area, the contribution due to the direct solar radiation is

$$G_{\text{dir}} = q''_{\text{dir}} \cdot \cos \theta.$$

From Eq. 12.17 the contribution due to the diffuse radiation is

$$G_{\text{dif}} = \pi I_{\text{dif}}.$$

Hence

$$G = G_{\text{dir}} + G_{\text{dif}} = q''_{\text{dir}} \cdot \cos \theta + \pi I_{\text{dif}}$$

or

$$G = 1000 \text{ W/m}^2 \times 0.866 + \pi \text{ sr} \times 70 \text{ W/m}^2 \cdot \text{sr}$$

$$G = (866 + 220) \text{ W/m}^2$$

or

$$G = 1086 \text{ W/m}^2.$$

<

**COMMENTS:** Although a diffuse approximation is often made for the non-direct component of solar radiation, the actual directional distribution deviates from this condition, providing larger intensities at angles close to the direct beam.

## PROBLEM 12.10

**KNOWN:** Daytime solar radiation conditions with direct solar intensity  $I_{\text{dir}} = 2.10 \times 10^7 \text{ W/m}^2 \cdot \text{sr}$  within the solid angle subtended with respect to the earth,  $\Delta\omega_{\text{S}} = 6.74 \times 10^{-5} \text{ sr}$ , and diffuse intensity  $I_{\text{dif}} = 70 \text{ W/m}^2 \cdot \text{sr}$ .

**FIND:** (a) Total solar irradiation at the earth's surface when the direct radiation is incident at  $30^\circ$ , and (b) Verify the prescribed value of  $\Delta\omega_{\text{S}}$  recognizing that the diameter of the earth is  $D_{\text{S}} = 1.39 \times 10^9 \text{ m}$ , and the distance between the sun and the earth is  $r_{\text{e-S}} = 1.496 \times 10^{11} \text{ m}$  (1 astronomical unit).

**SCHEMATIC:**

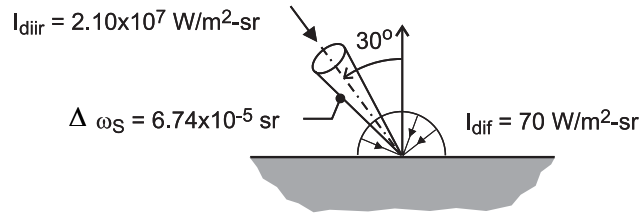

**ANALYSIS:** (a) From Eq. 12.22 the diffuse irradiation is

$$G_{\text{dif}} = \pi I_{\text{dif}} = \pi \text{ sr} \times 70 \text{ W/m}^2 \cdot \text{sr} = 220 \text{ W/m}^2$$

The direct irradiation follows from Eq. 12.18, expressed in terms of the solid angle

$$G_{\text{dir}} = I_{\text{dir}} \cos \theta \Delta\omega_{\text{S}}$$

$$G_{\text{dir}} = 2.10 \times 10^7 \text{ W/m}^2 \cdot \text{sr} \times \cos 30^\circ \times 6.74 \times 10^{-5} \text{ sr} = 1226 \text{ W/m}^2$$

The total solar irradiation is the sum of the diffuse and direct components,

$$G_{\text{S}} = G_{\text{dif}} + G_{\text{dir}} = (220 + 1226) \text{ W/m}^2 = 1446 \text{ W/m}^2 \quad <$$

(b) The solid angle the sun subtends with respect to the earth is calculated from Eq. 12.7,

$$\Delta\omega_{\text{S}} = \frac{dA_{\text{n}}}{r^2} = \frac{\pi D_{\text{S}}^2 / 4}{r_{\text{e-S}}^2} = \frac{\pi (1.39 \times 10^9 \text{ m})^2 / 4}{(1.496 \times 10^{11} \text{ m})^2} = 6.74 \times 10^{-5} \text{ sr} \quad <$$

where  $dA_{\text{n}}$  is the projected area of the sun and  $r_{\text{e-S}}$ , the distance between the earth and sun. We are assuming that  $r_{\text{e-S}}^2 \gg D_{\text{S}}^2$ .

**COMMENTS:** Can you verify that the direct solar intensity,  $I_{\text{dir}}$ , is a reasonable value, assuming that the solar disk emits as a black body at 5800 K?  $(I_{\text{b,S}} = \sigma T_{\text{S}}^4 / \pi = \sigma (5800 \text{ K})^4 / \pi = 2.04 \times 10^7 \text{ W/m}^2 \cdot \text{sr})$ . Because of local cloud formations, it is possible to have an appreciable diffuse component. But it is not likely to have such a high direct component as given in the problem statement.



### PROBLEM 12.11

**KNOWN:** Directional distribution of solar radiation intensity incident at earth's surface on an overcast day.

**FIND:** Solar irradiation at earth's surface.

**SCHEMATIC:**

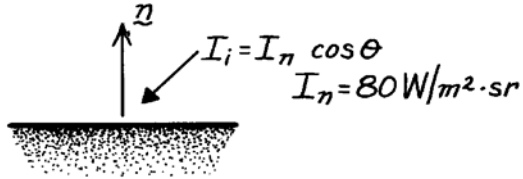

**ASSUMPTIONS:** (1) Intensity is independent of azimuthal angle  $\theta$ .

**ANALYSIS:** Applying Eq. 12.18 to the total intensity

$$G = \int_0^{2\pi} \int_0^{\pi/2} I_i(\theta) \cos \theta \sin \theta \, d\theta \, d\phi$$

$$G = 2\pi I_n \int_0^{\pi/2} \cos^2 \theta \sin \theta \, d\theta$$

$$G = (2\pi \text{ sr}) \times 80 \text{ W/m}^2 \cdot \text{sr} \left( -\frac{1}{3} \cos^3 \theta \right) \Big|_0^{\pi/2}$$

$$G = -167.6 \text{ W/m}^2 \cdot \text{sr} \left( \cos^3 \frac{\pi}{2} - \cos^3 0 \right)$$

$$G = 167.6 \text{ W/m}^2.$$

<

## PROBLEM 12.12

**KNOWN:** Hemispherical and spherical arrangements for radiant heat treatment of a thin-film material. Heater emits diffusely with intensity  $I_{e,h} = 169,000 \text{ W/m}^2 \cdot \text{sr}$  and has an area  $0.0052 \text{ m}^2$ .

**FIND:** (a) Expressions for the irradiation on the film as a function of the zenith angle,  $\theta$ , and (b) Identify arrangement which provides the more uniform irradiation, and hence better quality control for the treatment process.

**SCHEMATIC:**

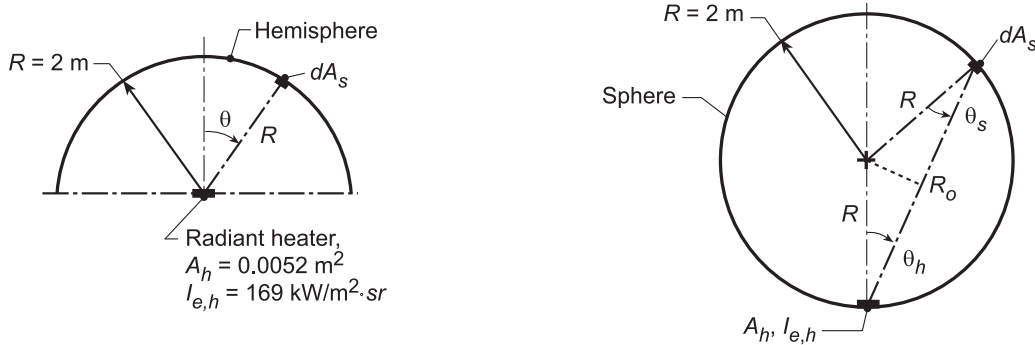

**ASSUMPTIONS:** (1) Heater emits diffusely, (2) All radiation leaving the heater is absorbed by the thin film.

**ANALYSIS:** (a) The irradiation on any differential area,  $dA_s$ , due to emission from the heater,  $A_h$ , follows from its definition, Section 12.3.3,

$$G = \frac{q_{h \rightarrow s}}{dA_s} \quad (1)$$

Where  $q_{h \rightarrow s}$  is the radiant heat rate leaving  $A_h$  and intercepted by  $dA_s$ . From Eq. 12.12,

$$q_{h \rightarrow s} = I_{e,h} \cdot dA_h \cos \theta_h \cdot \omega_{s-h} \quad (2)$$

where  $\omega_{s-h}$  is the solid angle  $dA_s$  subtends with respect to any point on  $A_h$ . From the definition, Eq. 12.7,

$$\omega = \frac{dA_n}{r^2} \quad (3)$$

where  $dA_n$  is normal to the viewing direction and  $r$  is the separation distance.

*For the hemisphere:* Referring to the schematic above, the solid angle is

$$\omega_{s-h} = \frac{dA_s}{R^2}$$

and the irradiation distribution on the hemispheric surface as a function of  $\theta_h$  is

$$G = I_{e,h} A_h \cos \theta_h / R^2 \quad (1) <$$

*For the sphere:* From the schematic, the solid angle is

$$\omega_{s,h} = \frac{dA_s \cos \theta_s}{R_o^2} = \frac{dA_s}{4R^2 \cos \theta_h}$$

where  $R_o$ , from the geometry of sphere cord and radii with  $\theta_s = \theta_h$ , is

Continued...

### PROBLEM 12.12 (Cont.)

$$R_o = 2R \cos \theta_h$$

and the irradiation distribution on the spherical surface as a function of  $\theta_h$  is

$$G = I_{e,h} d A_h / 4R^2 \quad (2) <$$

(b) The spherical shape provides more uniform irradiation as can be seen by comparing Eqs. (1) and (2). In fact, for the spherical shape, the irradiation on the thin film is uniform and therefore provides for better quality control for the treatment process. Substituting numerical values, the irradiations are:

$$G_{\text{hem}} = 169,000 \text{ W/m}^2 \cdot \text{sr} \times 0.0052 \text{ m}^2 \cos \theta_h / (2\text{m})^2 = 219.7 \cos \theta_h \text{ W/m}^2 \quad (3)$$

$$G_{\text{sph}} = 169,000 \text{ W/m}^2 \cdot \text{sr} \times 0.0052 \text{ m}^2 / 4(2\text{m})^2 = 54.9 \text{ W/m}^2 \quad (4)$$

**COMMENTS:** (1) The radiant heat rate leaving the diffuse heater surface by emission is

$$q_{\text{tot}} = \pi I_{e,h} A_h = 2761 \text{ W}$$

The average irradiation on the *spherical surface*,  $A_{\text{sph}} = 4\pi R^2$ ,

$$\bar{G}_{\text{sph}} = q_{\text{tot}} / A_{\text{sph}} = 2761 \text{ W} / 4\pi (2\text{m})^2 = 54.9 \text{ W/m}^2$$

while the average irradiation on the *hemispherical surface*,  $A_{\text{hem}} = 2\pi R^2$  is

$$\bar{G}_{\text{hem}} = 2761 \text{ W} / 2\pi (2\text{m})^2 = 109.9 \text{ W/m}^2$$

(2) Note from the foregoing analyses for the *sphere* that the result for  $\bar{G}_{\text{sph}}$  is identical to that found as Eq. (4). That follows since the irradiation is uniform.

(3) Note that  $\bar{G}_{\text{hem}} > \bar{G}_{\text{sph}}$  since the surface area of the hemisphere is half that of the sphere.

Recognize that for the hemisphere thin film arrangement, the distribution of the irradiation is quite variable with a maximum at  $\theta = 0^\circ$  (top) and half the maximum value at  $\theta = 30^\circ$ .

### PROBLEM 12.13

**KNOWN:** Hot part,  $\Delta A_p$ , located a distance  $x_1$  from an origin directly beneath a motion sensor at a distance  $L_d = 1$  m.

**FIND:** (a) Location  $x_1$  at which sensor signal  $S_1$  will be 75% that corresponding to  $x = 0$ , directly beneath the sensor,  $S_o$ , and (b) Compute and plot the signal ratio,  $S/S_o$ , as a function of the part position  $x_1$  for the range  $0.2 \leq S/S_o \leq 1$  for  $L_d = 0.8, 1.0$  and  $1.2$  m; compare the  $x$ -location for each value of  $L_d$  at which  $S/S_o = 0.75$ .

**SCHEMATIC:**

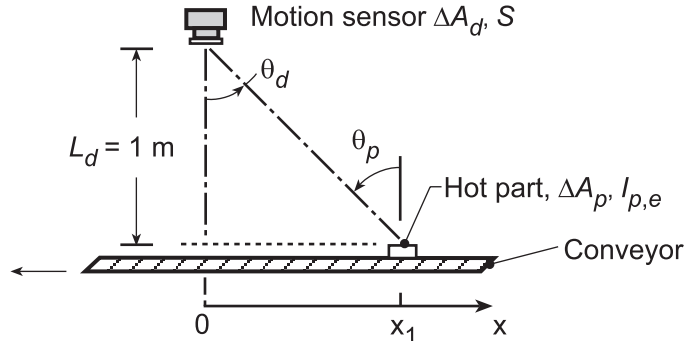

**ASSUMPTIONS:** (1) Hot part is diffuse emitter, (2)  $L_d^2 \gg \Delta A_p, \Delta A_o$ .

**ANALYSIS:** (a) The sensor signal,  $S$ , is proportional to the radiant power leaving  $\Delta A_p$  and intercepted by  $\Delta A_d$ ,

$$S \sim q_{p \rightarrow d} = I_{p,e} \Delta A_p \cos \theta_p \Delta \omega_{d-p} \quad (1)$$

when

$$\cos \theta_p = \cos \theta_d = \frac{L_d}{R} = L_d / (L_d^2 + x_1^2)^{1/2} \quad (2)$$

$$\Delta \omega_{d-p} = \frac{\Delta A_d \cdot \cos \theta_d}{R^2} = \Delta A_d \cdot L_d / (L_d^2 + x_1^2)^{3/2} \quad (3)$$

Hence,

$$q_{p \rightarrow d} = I_{p,e} \Delta A_p \Delta A_d \frac{L_d^2}{(L_d^2 + x_1^2)^2} \quad (4)$$

It follows that, with  $S_o$  occurring when  $x = 0$  and  $L_d = 1$  m,

$$\frac{S}{S_o} = \frac{L_d^2 / (L_d^2 + x_1^2)^2}{L_d^2 / (L_d^2 + 0^2)^2} = \left[ \frac{L_d^2}{L_d^2 + x_1^2} \right]^2 \quad (5)$$

so that when  $S/S_o = 0.75$ , find,

$$x_1 = 0.393 \text{ m} \quad \leftarrow$$

(b) Using Eq. (5) in the IHT workspace, the signal ratio,  $S/S_o$ , has been computed and plotted as a function of the part position  $x$  for selected  $L_d$  values.

Continued...

**PROBLEM 12.13 (Cont.)**

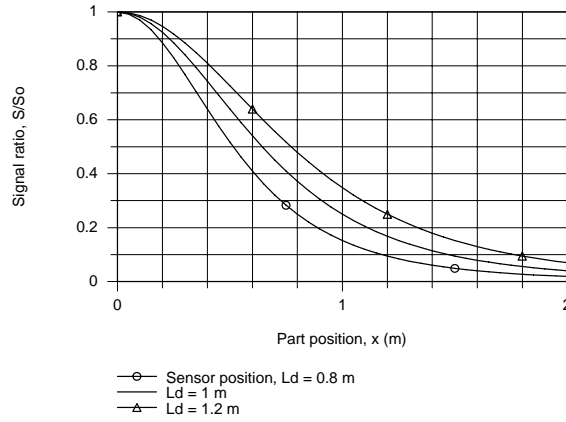

When the part is directly under the sensor,  $x = 0$ ,  $S/S_o = 1$  for all values of  $L_d$ . With increasing  $x$ ,  $S/S_o$  decreases most rapidly with the smallest  $L_d$ . From the IHT model we found the part position  $x$  corresponding to  $S/S_o = 0.75$  as follows.

$S/S_o$	$L_d$ (m)	$x_1$ (m)
0.75	0.8	0.315
0.75	1.0	0.393
0.75	1.2	0.472

If the sensor system is set so that when  $S/S_o$  reaches 0.75 a process is initiated, the technician can use the above plot and table to determine at what position the part will begin to experience the treatment process.

## PROBLEM 12.14

**KNOWN:** Surface area, and emission from area  $A_1$ . Size and orientation of area  $A_2$ .

**FIND:** (a) Irradiation of  $A_2$  by  $A_1$  for  $L_1 = 1$  m,  $L_2 = 0.5$  m, (b) Irradiation of  $A_2$  over the range  $0 \leq L_2 \leq 10$  m.

**SCHEMATIC:**

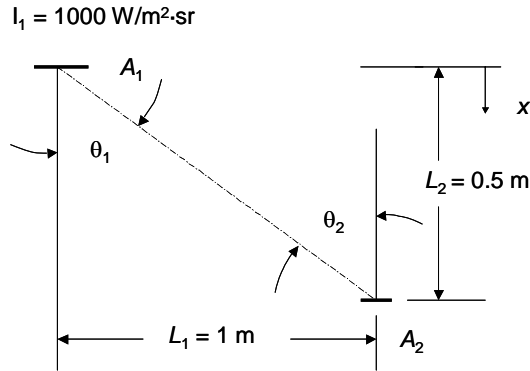

**ASSUMPTIONS:** Diffuse emission.

**ANALYSIS:** (a) The irradiation of Surface 1 is  $G_{1-2} = q_{1-2}/A_2$  and from Example 12.1,

$$q_{1-2} = I_1 A_1 \cos \theta_1 \omega_{2-1} = I_1 A_1 \cos \theta_1 A_2 \cos \theta_2 / r^2$$

Since  $\theta_1 = \theta_2 = \theta = \tan^{-1}(L_1/L_2) = \tan^{-1}(1/0.5) = 63.43^\circ$  and  $r^2 = L_1^2 + L_2^2 = (1\text{m})^2 + (0.5\text{m})^2 = 1.25 \text{ m}^2$ ,

$$G_{1-2} = I_1 A_1 \cos^2 \theta / r^2 = 1000 \text{ W/m}^2 \cdot \text{sr} \times 2 \times 10^{-4} \text{ m}^2 \times \cos^2(63.43^\circ) / 1.25 \text{ m}^2 = 0.032 \text{ W/m}^2 \quad \leftarrow$$

(b) The preceding equations may be solved for various values of  $L_2$ . The irradiation over the range  $0 \leq L_2 \leq 10$  m is shown below.

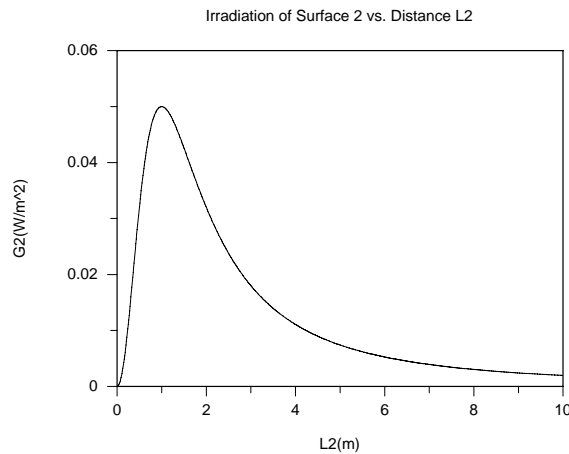

**COMMENTS:** The irradiation is zero for  $L_2 = 0$  and  $L_2 \rightarrow \infty$ .

### PROBLEM 12.15

**KNOWN:** Emissive power of a diffuse surface.

**FIND:** Fraction of emissive power that leaves surface in the directions  $\pi/4 \leq \theta \leq \pi/2$  and  $0 \leq \phi \leq \pi$ .

**SCHEMATIC:**

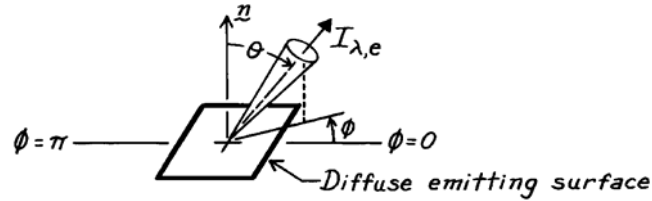

**ASSUMPTIONS:** (1) Diffuse emitting surface.

**ANALYSIS:** According to Eq. 12.15, the total, hemispherical emissive power is

$$E = \int_0^{\infty} \int_0^{2\pi} \int_0^{\pi/2} I_{\lambda, e}(\lambda, \theta, \phi) \cos \theta \sin \theta \, d\theta \, d\phi \, d\lambda.$$

For a diffuse surface  $I_{\lambda, e}(\lambda, \theta, \phi)$  is independent of direction, and as given by Eq. 12.17,

$$E = \pi I_e.$$

The emissive power, which has directions prescribed by the limits on  $\theta$  and  $\phi$ , is

$$\begin{aligned} \Delta E &= \int_0^{\infty} I_{\lambda, e}(\lambda) \, d\lambda \left[ \int_0^{\pi} d\phi \right] \left[ \int_{\pi/4}^{\pi/2} \cos \theta \sin \theta \, d\theta \right] \\ \Delta E &= I_e [\phi]_0^{\pi} \times \left[ \frac{\sin^2 \theta}{2} \right]_{\pi/4}^{\pi/2} = I_e [\pi] \left[ \frac{1}{2} (1 - 0.707^2) \right] \end{aligned}$$

$$\Delta E = 0.25 \pi I_e.$$

It follows that

$$\frac{\Delta E}{E} = \frac{0.25 \pi I_e}{\pi I_e} = 0.25.$$

<

**COMMENTS:** The diffuse surface is an important concept in radiation heat transfer, and the directional independence of the intensity should be noted.

## PROBLEM 12.16

**KNOWN:** Spectral distribution of  $E_\lambda$  for a diffuse surface.

**FIND:** (a) Total emissive power  $E$ , (b) Total intensity associated with directions  $\theta = 0^\circ$  and  $\theta = 30^\circ$ , and (c) Fraction of emissive power leaving the surface in directions  $\pi/4 \leq \theta \leq \pi/2$ .

**SCHEMATIC:**

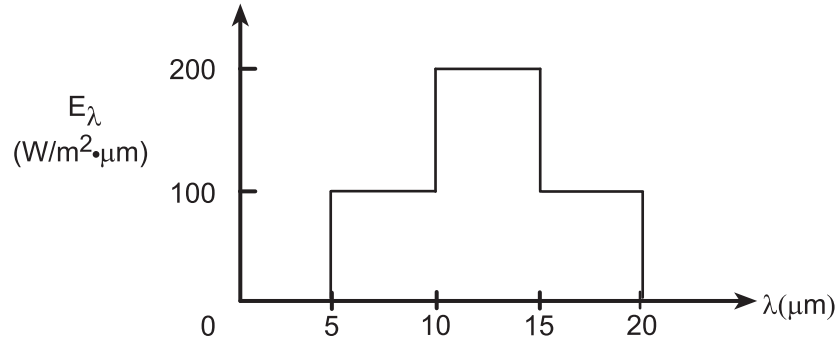

**ASSUMPTIONS:** (1) Diffuse emission.

**ANALYSIS:** (a) From Eq. 12.14 it follows that

$$E = \int_0^{\infty} E_\lambda(\lambda) d\lambda = \int_0^5 (0) d\lambda + \int_5^{10} (100) d\lambda + \int_{10}^{15} (200) d\lambda + \int_{15}^{20} (100) d\lambda + \int_{20}^{\infty} (0) d\lambda$$

$$E = 100 \text{ W/m}^2 \cdot \mu\text{m} (10 - 5) \mu\text{m} + 200 \text{ W/m}^2 \cdot \mu\text{m} (15 - 10) \mu\text{m} + 100 \text{ W/m}^2 \cdot \mu\text{m} (20 - 15) \mu\text{m}$$

$$E = 2000 \text{ W/m}^2 \quad <$$

(b) For a diffuse emitter,  $I_e$  is independent of  $\theta$  and Eq. 12.17 gives

$$I_e = \frac{E}{\pi} = \frac{2000 \text{ W/m}^2}{\pi \text{ sr}}$$

$$I_e = 637 \text{ W/m}^2 \cdot \text{sr} \quad <$$

(c) Since the surface is diffuse, use Eqs. 12.13 and 12.17,

$$\frac{E(\pi/4 \rightarrow \pi/2)}{E} = \frac{\int_0^{2\pi} \int_{\pi/4}^{\pi/2} I_e \cos \theta \sin \theta d\theta d\phi}{\pi I_e}$$

$$\frac{E(\pi/4 \rightarrow \pi/2)}{E} = \frac{\int_{\pi/4}^{\pi/2} \cos \theta \sin \theta d\theta \int_0^{2\pi} d\phi}{\pi} = \frac{1}{\pi} \left[ \frac{\sin^2 \theta}{2} \right]_{\pi/4}^{\pi/2} \phi \Big|_0^{2\pi}$$

$$\frac{E(\pi/4 \rightarrow \pi/2)}{E} = \frac{1}{\pi} \left[ \frac{1}{2} (1^2 - 0.707^2) (2\pi - 0) \right] = 0.50 \quad <$$

**COMMENTS:** (1) Note how a spectral integration may be performed in parts.

(2) In performing the integration of part (c), recognize the significance of the diffuse emission assumption for which the intensity is uniform in all directions.



## PROBLEM 12.17

**KNOWN:** Diffuse surface  $\Delta A_o$ , 5-mm square, with total emissive power  $E_o = 4000 \text{ W/m}^2$ .

**FIND:** (a) Rate at which radiant energy is emitted by  $\Delta A_o$ ,  $q_{\text{emit}}$ ; (b) Intensity  $I_{o,e}$  of the radiation field emitted from the surface  $\Delta A_o$ ; (c) Expression for  $q_{\text{emit}}$  presuming knowledge of the intensity  $I_{o,e}$  beginning with Eq. 12.13; (d) Rate at which radiant energy is incident on the hemispherical surface,  $r = R_1 = 0.5 \text{ m}$ , due to emission from  $\Delta A_o$ ; (e) Rate at which radiant energy leaving  $\Delta A_o$  is intercepted by the small area  $\Delta A_2$  located in the direction  $(40^\circ, \phi)$  on the hemispherical surface using Eq. 12.10; also determine the irradiation on  $\Delta A_2$ ; (f) Repeat part (e), for the location  $(0^\circ, \phi)$ ; are the irradiances at the two locations equal? and (g) Irradiation  $G_1$  on the hemispherical surface at  $r = R_1$  using Eq. 12.18.

**SCHEMATIC:**

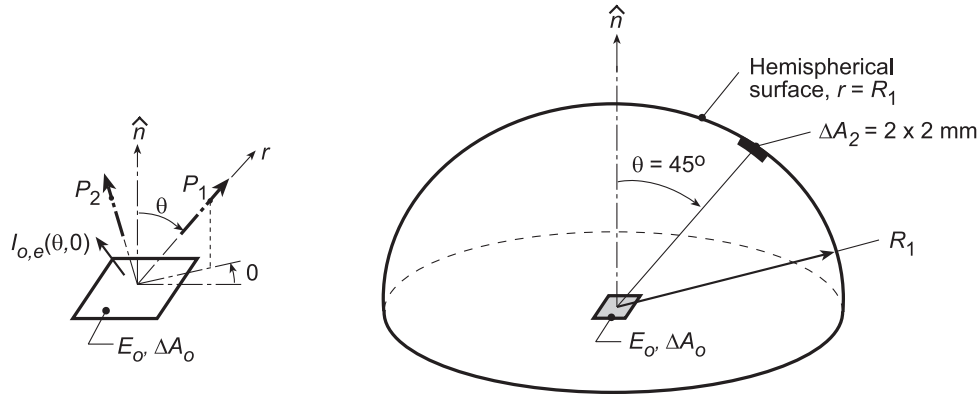

**ASSUMPTIONS:** (1) Diffuse surface,  $\Delta A_o$ , (2) Medium above  $\Delta A_o$  is also non-participating, (3)  $R_1^2 \gg \Delta A_o, \Delta A_2$ .

**ANALYSIS:** (a) The radiant power leaving  $\Delta A_o$  by emission is

$$q_{\text{emit}} = E_o \cdot \Delta A_o = 4000 \text{ W/m}^2 (0.005 \text{ m} \times 0.005 \text{ m}) = 0.10 \text{ W} \quad <$$

(b) The emitted intensity is  $I_{o,e}$  and is independent of direction since  $\Delta A_o$  is a diffuser emitter,

$$I_{o,e} = E_o / \pi = 1273 \text{ W/m}^2 \cdot \text{sr} \quad <$$

The intensities at points  $P_1$  and  $P_2$  are also  $I_{o,e}$  and the intensity in the directions shown in the schematic above will remain constant no matter how far the point is from the surface  $\Delta A_o$  since the space is non-participating.

(c) From knowledge of  $I_{o,e}$ , the radiant power leaving  $\Delta A_o$  from Eq. 12.13 is,

$$q_{\text{emit}} = \int_{\text{h}} I_{o,e} \Delta A_o \cos \theta \sin \theta d\theta d\phi = I_{o,e} \Delta A_o \int_{\phi=0}^{2\pi} \int_{\theta=0}^{\pi/2} \cos \theta \sin \theta d\theta d\phi = \pi I_{o,e} \Delta A_o = 0.10 \text{ W} \quad <$$

(d) Defining control surfaces above  $\Delta A_o$  and on  $A_1$ , the radiant power leaving  $\Delta A_o$  must pass through  $A_1$ . That is,

$$q_{1,\text{inc}} = E_o \Delta A_o = 0.10 \text{ W} \quad <$$

Recognize that the average irradiation on the hemisphere,  $A_1$ , where  $A_1 = 2\pi R_1^2$ , based upon the definition, Section 12.3.3,

$$\bar{G}_1 = q_{1,\text{inc}} / A_1 = E_o \Delta A_o / 2\pi R_1^2 = 63.7 \text{ mW/m}^2$$

where  $q_{1,\text{inc}}$  is the radiant power incident on surface  $A_1$ .

Continued...

**PROBLEM 12.17 (Cont.)**

(e) The radiant power leaving  $\Delta A_o$  intercepted by  $\Delta A_2$ , where  $\Delta A_2 = 4 \times 10^{-6} \text{ m}^2$ , located at  $(\theta = 45^\circ, \phi)$  as per the schematic, follows from Eq. 12.10,

$$q_{\Delta A_o \rightarrow \Delta A_2} = I_{o,e} \Delta A_o \cos \theta_o \Delta \omega_{2-o}$$

where  $\theta_o = 45^\circ$  and the solid angle  $\Delta A_2$  subtends with respect to  $\Delta A_o$  is

$$\Delta \omega_{2-o} = \Delta A_2 \cos \theta_2 / R_1^2 = 4 \times 10^{-6} \text{ m}^2 \cdot 1 / (0.5 \text{ m})^2 = 1.60 \times 10^{-5} \text{ sr}$$

where  $\theta_2 = 0^\circ$ , the direction normal to  $\Delta A_2$ ,

$$q_{\Delta A_o \rightarrow \Delta A_2} = 1273 \text{ W/m}^2 \cdot \text{sr} \times 25 \times 10^{-6} \text{ m}^2 \cos 45^\circ \times 1.60 \times 10^{-5} \text{ sr} = 3.60 \times 10^{-7} \text{ W} \quad <$$

From the definition of irradiation, Section 12.3.3,

$$G_2 = q_{\Delta A_o \rightarrow \Delta A_2} / \Delta A_2 = 90 \text{ mW/m}^2$$

(f) With  $\Delta A_2$ , located at  $(\theta = 0^\circ, \phi)$ , where  $\cos \theta_o = 1$ ,  $\cos \theta_2 = 1$ , find

$$\Delta \omega_{2-o} = 1.60 \times 10^{-5} \text{ sr} \quad q_{\Delta A_o \rightarrow \Delta A_2} = 5.09 \times 10^{-7} \text{ W} \quad G_2 = 127 \text{ mW/m}^2 \quad <$$

Note that the irradiation on  $\Delta A_2$  when it is located at  $(0^\circ, \phi)$  is larger than when  $\Delta A_2$  is located at  $(45^\circ, \phi)$ ; that is,  $127 \text{ mW/m}^2 > 90 \text{ mW/m}^2$ . Is this intuitively satisfying?

(g) Using Eq. 12.18, based upon Figure 12.10, find

$$\bar{G}_1 = \int_h I_{1,i} dA_1 \cdot d\omega_{0-1} / A_1 = \pi I_{o,e} \Delta A_o / \Delta A_1 = 63.7 \text{ mW/m}^2 \quad <$$

where the elemental area on the hemispherical surface  $A_1$  and the solid angle  $\Delta A_o$  subtends with respect to  $\Delta A_1$  are, respectively,

$$dA_1 = R_1^2 \sin \theta d\theta d\phi \quad d\omega_{0-1} = \Delta A_o \cos \theta / R_1^2$$

From this calculation you found that the *average* irradiation on the hemisphere surface,  $r = R_1$ , is  $\bar{G}_1 = 63.7 \text{ mW/m}^2$ . From parts (e) and (f), you found irradiations,  $G_2$  on  $\Delta A_2$  at  $(0^\circ, \phi)$  and  $(45^\circ, \phi)$  as  $127 \text{ mW/m}^2$  and  $90 \text{ mW/m}^2$ , respectively. Did you expect  $\bar{G}_1$  to be less than either value for  $G_2$ ? How do you explain this?

**COMMENTS:** (1) Note that from Parts (e) and (f) that the irradiation on  $A_1$  is not uniform. Parts (d) and (g) give an average value.

(2) What conclusions would you reach regarding  $G_1$  if  $\Delta A_o$  were a sphere?

## PROBLEM 12.18

**KNOWN:** Intensities of radiating various surfaces of known areas.

**FIND:** Surface temperature and emitted energy assuming blackbody behavior.

**SCHEMATIC:**

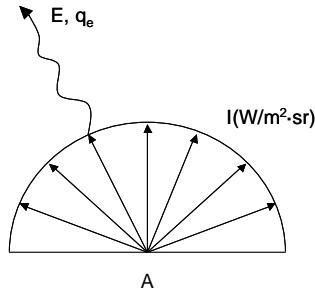

**ANALYSIS:** For blackbody emission,  $T = \left(\frac{E}{\sigma}\right)^{1/4}$  and  $E = \pi I$ . Therefore,

$$T = \left(\frac{\pi I_e}{\sigma}\right)^{1/4} ; \quad q_e = AE = A\pi I_e \quad (1,2)$$

Equations (1) and (2) may be used to find T and  $q_e$  as follows. <

Problem	$I_e$ (W/m <sup>2</sup> ·sr)	A (m <sup>2</sup> )	T (K)	$q_e$ (W)
Example 12.1	7000	10 <sup>-3</sup>	789	22
Problem 12.8	1.2 × 10 <sup>5</sup>	10 <sup>-4</sup>	1606	37.7
Problem 12.12	169,000	0.0052	1750	2761
Problem 12.14	1000	2 × 10 <sup>-4</sup>	485	0.628

**COMMENTS:** If the surface is not black, the intensity leaving the surface will include a reflected component.

## PROBLEM 12.19

**KNOWN:** Diameter and temperature of burner. Temperature of ambient air. Burner efficiency.

**FIND:** (a) Radiation and convection heat rates, and wavelength corresponding to maximum spectral emission. Rate of electric energy consumption. (b) Effect of burner temperature on convection and radiation rates.

**SCHEMATIC:**

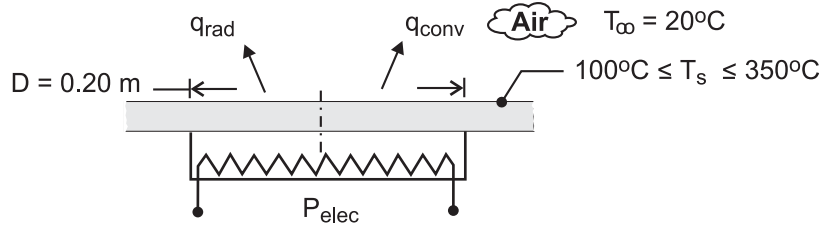

**ASSUMPTIONS:** (1) Burner emits as a blackbody, (2) Negligible irradiation of burner from surrounding, (3) Ambient air is quiescent, (4) Constant properties.

**PROPERTIES:** Table A-4, air ( $T_f = 408 \text{ K}$ ):  $k = 0.0344 \text{ W/m}\cdot\text{K}$ ,  $\nu = 27.4 \times 10^{-6} \text{ m}^2/\text{s}$ ,  $\alpha = 39.7 \times 10^{-6} \text{ m}^2/\text{s}$ ,  $\text{Pr} = 0.70$ ,  $\beta = 0.00245 \text{ K}^{-1}$ .

**ANALYSIS:** (a) For emission from a blackbody

$$q_{\text{rad}} = A_s E_b = \left( \pi D^2 / 4 \right) \sigma T^4 = \left[ \pi (0.2\text{m})^2 / 4 \right] 5.67 \times 10^{-8} \text{ W/m}^2 \cdot \text{K}^4 (523\text{K})^4 = 133 \text{ W} \quad <$$

With  $L = A_s/P = D/4 = 0.05\text{m}$  and  $\text{Ra}_L = g\beta(T_s - T_\infty) L^3 / \alpha\nu = 9.8 \text{ m/s}^2 \times 0.00245 \text{ K}^{-1} (230 \text{ K}) (0.05\text{m})^3 / (27.4 \times 39.7 \times 10^{-12} \text{ m}^4/\text{s}^2) = 6.35 \times 10^5$ , Eq. 9.30 yields

$$\bar{h} = \frac{k}{L} \overline{\text{Nu}}_L = \left( \frac{k}{L} \right) 0.54 \text{ Ra}_L^{1/4} = \left( \frac{0.0344 \text{ W/m}\cdot\text{K}}{0.05\text{m}} \right) 0.54 (6.35 \times 10^5)^{1/4} = 10.5 \text{ W/m}^2 \cdot \text{K}$$

$$q_{\text{conv}} = \bar{h} A_s (T_s - T_\infty) = 10.5 \text{ W/m}^2 \cdot \text{K} \left[ \pi (0.2\text{m})^2 / 4 \right] 230 \text{ K} = 75.7 \text{ W} \quad <$$

The electric power requirement is then

$$P_{\text{elec}} = \frac{q_{\text{rad}} + q_{\text{conv}}}{\eta} = \frac{(133 + 75.7) \text{ W}}{0.9} = 232 \text{ W} \quad <$$

The wavelength corresponding to peak emission is obtained from Wien's displacement law, Eq. 12.31

$$\lambda_{\text{max}} = 2898 \mu\text{m} \cdot \text{K} / 523\text{K} = 5.54 \mu\text{m} \quad <$$

(b) As shown below, and as expected, the radiation rate increases more rapidly with temperature than the convection rate due to its stronger temperature dependence ( $T_s^4$  vs.  $T_s^{5/4}$ ).

Continued ...

### PROBLEM 12.19 (Cont.)

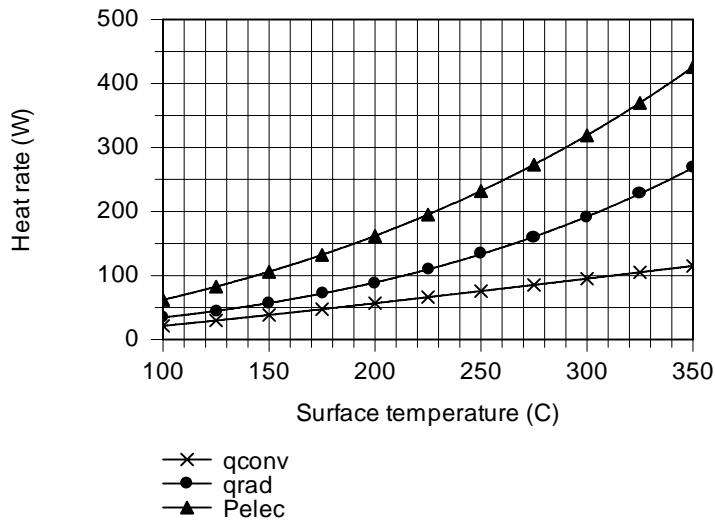

**COMMENTS:** If the surroundings are treated as a large enclosure with isothermal walls at  $T_{\text{sur}} = T_{\infty} = 293 \text{ K}$ , irradiation of the burner would be  $G = \sigma T_{\text{sur}}^4 = 418 \text{ W/m}^2$  and the corresponding heat rate would be  $A_s G = 13 \text{ W}$ . This input is much smaller than the energy outflows due to convection and radiation and is justifiably neglected.

## PROBLEM 12.20

**KNOWN:** Solar flux at outer edge of earth's atmosphere,  $1368 \text{ W/m}^2$ .

**FIND:** (a) Emissive power of sun, (b) Surface temperature of sun, (c) Wavelength of maximum solar emission, (d) Earth equilibrium temperature.

**SCHEMATIC:**

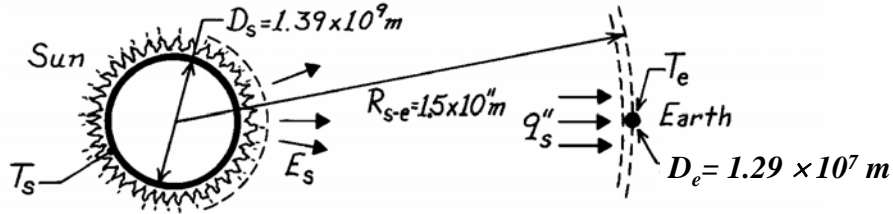

**ASSUMPTIONS:** (1) Sun and earth emit as blackbodies, (2) No attenuation of solar radiation enroute to earth, (3) Earth atmosphere has no effect on earth energy balance.

**ANALYSIS:** (a) Applying conservation of energy to the solar energy crossing two concentric spheres, one having the radius of the sun and the other having the radial distance from the edge of the earth's atmosphere to the center of the sun

$$E_s \left( \pi D_s^2 \right) = 4\pi \left( R_{s-e} - \frac{D_e}{2} \right)^2 q''_s.$$

Hence

$$E_s = \frac{4 \left( 1.5 \times 10^{11} \text{ m} - 0.65 \times 10^7 \text{ m} \right)^2 \times 1368 \text{ W/m}^2}{\left( 1.39 \times 10^9 \text{ m} \right)^2} = 6.37 \times 10^7 \text{ W/m}^2. \quad <$$

(b) From Eq. 12.32, the temperature of the sun is

$$T_s = \left( \frac{E_s}{\sigma} \right)^{1/4} = \left( \frac{6.37 \times 10^7 \text{ W/m}^2}{5.67 \times 10^{-8} \text{ W/m}^2 \cdot \text{K}^4} \right)^{1/4} = 5790 \text{ K}. \quad <$$

(c) From Wien's displacement law, Eq. 12.25, the wavelength of maximum emission is

$$\lambda_{\max} = \frac{C_3}{T} = \frac{2898 \mu\text{m} \cdot \text{K}}{5790 \text{ K}} = 0.50 \mu\text{m}.$$

(d) From an energy balance on the earth's surface

$$E_e \left( \pi D_e^2 \right) = q''_S \left( \pi D_e^2 / 4 \right).$$

Hence, from Eq. 12.26,

$$T_e = \left( \frac{q''_S}{4\sigma} \right)^{1/4} = \left( \frac{1368 \text{ W/m}^2}{4 \times 5.67 \times 10^{-8} \text{ W/m}^2 \cdot \text{K}^4} \right)^{1/4} = 279 \text{ K}. \quad <$$

**COMMENTS:** The average earth temperature is higher than 279 K due to the shielding effect of the earth's atmosphere (transparent to solar radiation but not to longer wavelength earth emission).

## PROBLEM 12.21

**KNOWN:** Small flat plate positioned just beyond the earth's atmosphere oriented such that its normal passes through the center of the sun. Pertinent earth-sun dimensions from Problem 12.20.

**FIND:** (a) Solid angle subtended by the sun about a point on the surface of the plate, (b) Incident intensity,  $I_i$ , on the plate using the known value of the solar irradiation about the earth's atmosphere,  $G_S = 1368 \text{ W/m}^2$ , and (c) Sketch of the incident intensity as a function of the zenith angle  $\theta$ , where  $\theta$  is measured from the normal to the plate.

**SCHEMATIC:**

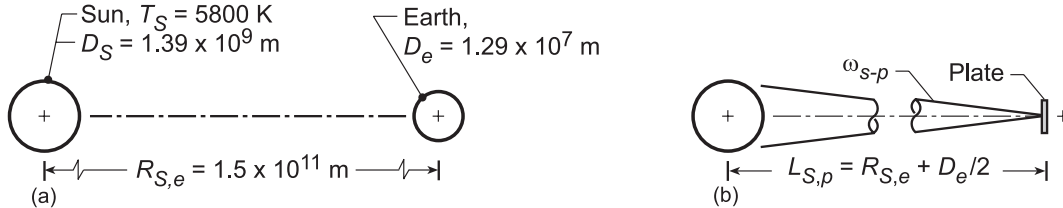

**ASSUMPTIONS:** (1) Plate oriented normal to centerline between sun and earth, (2) Height of earth's atmosphere negligible compared to distance from the sun to the plate, (3) Dimensions of the plate are very small compared to sun-earth dimensions.

**ANALYSIS:** (a) The pertinent sun-earth dimensions are shown in the schematic (a) above while the position of the plate relative to the sun and the earth is shown in (b). The solid angle subtended by the sun with respect to any point on the plate follows from Eq. 12.7,

$$\omega_{S-p} = \frac{A_S \cos \theta_p}{L_{S,p}^2} = \frac{\left(\frac{\pi D_S^2}{4}\right) \cos \theta_p}{(R_{S,e})^2} = \frac{\pi (1.39 \times 10^9 \text{ m})^2 / 4 \times 1}{(1.5 \times 10^{11} \text{ m})^2} = 6.74 \times 10^{-5} \text{ sr} \quad (1) <$$

where  $A_S$  is the projected area of the sun (the solar disk),  $\theta_p$  is the zenith angle measured between the plate normal and the centerline between the sun and earth, and  $L_{S,p}$  is the separation distance between the plate at the sun's center.

(b) The plate is irradiated by solar flux in the normal direction only (not diffusely). Using Eq. 12.18, the radiant power incident on the plate can be expressed as

$$G_S \Delta A_p = I_i \cdot \Delta A_p \cos \theta_p \cdot \omega_{S-p} \quad (2)$$

and the intensity  $I_i$  due to the solar irradiation  $G_S$  with  $\cos \theta_p = 1$ ,

$$I_i = G_S / \omega_{S-p} = 1368 \text{ W/m}^2 / 6.74 \times 10^{-5} \text{ sr} = 2.03 \times 10^7 \text{ W/m}^2 \cdot \text{sr} \quad <$$

(c) As illustrated in the schematic to the right, the intensity  $I_i$  will be constant for the zenith angle range  $0 \leq \theta_p \leq \theta_{p,o}$  where

$$\theta_{p,o} = \frac{D_S/2}{L_{S,p}} = \frac{1.39 \times 10^9 \text{ m}/2}{1.5 \times 10^{11} \text{ m}}$$

$$\theta_{p,o} = 4.633 \times 10^{-3} \text{ rad} \approx 0.27^\circ$$

For the range  $\theta_p > \theta_{p,o}$ , the intensity will be zero. Hence the  $I_i$  as a function of  $\theta_p$  will appear as shown to the right.

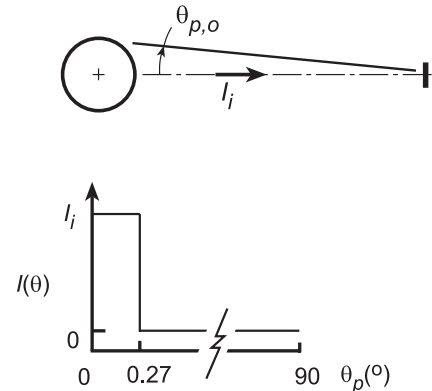

## PROBLEM 12.22

**KNOWN:** Evacuated, aluminum sphere ( $D = 2\text{m}$ ) serving as a radiation test chamber.

**FIND:** Irradiation on a small test object when the inner surface is lined with carbon black and at  $600\text{K}$ . What effect will surface coating have?

**SCHEMATIC:**

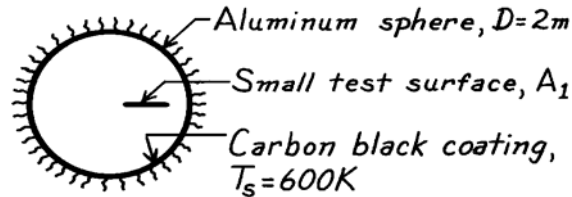

**ASSUMPTIONS:** (1) Sphere walls are isothermal, (2) Test surface area is small compared to the enclosure surface.

**ANALYSIS:** It follows from the discussion of Section 12.4 that this isothermal sphere is an enclosure behaving as a blackbody. For such a condition, see Fig. 12.11(c), the irradiation on a small surface within the enclosure is equal to the blackbody emissive power at the temperature of the enclosure. That is

$$G_1 = E_b(T_s) = \sigma T_s^4$$

$$G_1 = 5.67 \times 10^{-8} \text{W/m}^2 \cdot \text{K}^4 (600\text{K})^4 = 7348 \text{W/m}^2.$$

<

The irradiation is independent of the nature of the enclosure surface coating properties.

**COMMENTS:** (1) The irradiation depends only upon the enclosure surface temperature and is independent of the enclosure surface properties. (2) Note that the test surface area must be small compared to the enclosure surface area. This allows for inter-reflections to occur such that the radiation field, within the enclosure will be uniform (diffuse) or isotropic. (3) The irradiation level would be the same if the enclosure were not evacuated since, in general, air would be a non-participating medium.



## PROBLEM 12.23

**KNOWN:** Diameter of spherical fuel pellet. Pellet emissivity and absorptivity. Laser power and number of lasers. Laser entrance hole diameters.

**FIND:** (a) Maximum fuel temperature for direct laser irradiation. (b) Maximum fuel temperature for irradiation using the enclosure.

**SCHEMATIC:**

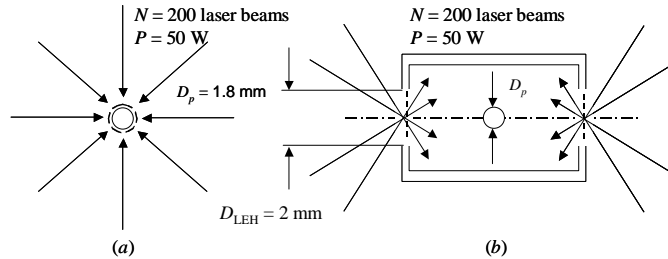

**ASSUMPTIONS:** (1) Steady state conditions. (2) Negligible irradiation from surroundings. (3) Uniform temperature inside enclosure. (4) Enclosure behaves as a blackbody. (5) Negligible heat loss through enclosure walls.

**PROPERTIES:** Given:  $\varepsilon = 0.8$ ,  $\alpha = 0.3$ .

**ANALYSIS:**

(a) An energy balance on the spherical pellet yields

$$\dot{E}_{in} = \dot{E}_{out} = \alpha NP = (\pi D_p^2) \varepsilon \sigma T_p^4$$

or

$$T_p = \left( \frac{\alpha NP}{\varepsilon \sigma \pi D_p^2} \right)^{1/4} = \left( \frac{0.3 \times 200 \times 500 \text{ W}}{0.8 \times 5.67 \times 10^{-8} \text{ W/m}^2 \text{K}^4 \times \pi \times (1.8 \times 10^{-3} \text{ m})^2} \right)^{1/4} = 15,970 \text{ K} \quad <$$

(b) An energy balance on the enclosure yields

$$\dot{E}_{in} = \dot{E}_{out} = NP = 2 \left( \pi D_{LEH}^2 / 4 \right) \sigma T_e^4$$

or

$$T_e = \left( \frac{2NP}{\sigma \pi D_{LEH}^2} \right)^{1/4} = \left( \frac{2 \times 200 \times 500 \text{ W}}{5.67 \times 10^{-8} \text{ W/m}^2 \text{K}^4 \times \pi \times (2.0 \times 10^{-3} \text{ m})^2} \right)^{1/4} = 23,020 \text{ K}$$

Since the enclosure temperature is assumed to be uniform,  $T_p = T_e = 23,020 \text{ K}$  <

**COMMENTS:** (1) The temperature of the pellet is increased by 44% by placing it in the enclosure. (2) The actual maximum temperature of the pellet in the enclosure can be much less than calculated if the area of the laser entrance holes is not small relative to the interior area of the enclosure. (3) The temperatures are extremely high, as required. (4) This problem is motivated by the U.S. National Ignition Facility at the Lawrence Livermore National Laboratory. The lasers used to heat the 1.8 mm diameter pellet occupy a facility that is 10 stories tall with a footprint the size of three football fields.

### PROBLEM 12.24

**KNOWN:** Isothermal enclosure of surface area,  $A_s$ , and small opening,  $A_o$ , through which 70W emerges.

**FIND:** (a) Temperature of the interior enclosure wall if the surface is black, (b) Temperature of the wall surface having  $\epsilon = 0.15$ .

**SCHEMATIC:**

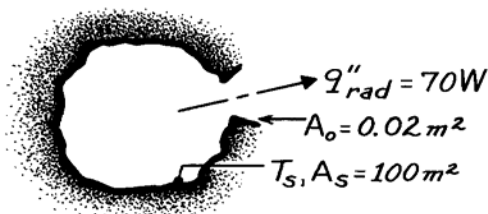

**ASSUMPTIONS:** (1) Enclosure is isothermal, (2)  $A_o \ll A_s$ .

**ANALYSIS:** A characteristic of an isothermal enclosure, according to Section 12.4, is that the radiant power emerging through a small aperture will correspond to blackbody conditions. Hence

$$q_{\text{rad}} = A_o E_b(T_s) = A_o \sigma T_s^4$$

where  $q_{\text{rad}}$  is the radiant power leaving the enclosure opening. That is,

$$T_s = \left( \frac{q_{\text{rad}}}{A_o \sigma} \right)^{1/4} = \left( \frac{70\text{W}}{0.02\text{m}^2 \times 5.670 \times 10^{-8} \text{W/m}^2 \cdot \text{K}^4} \right)^{1/4} = 498\text{K.} \quad <$$

Recognize that the radiated power will be independent of the emissivity of the wall surface. As long as  $A_o \ll A_s$  and the enclosure is isothermal, then the radiant power will depend only upon the temperature.

**COMMENTS:** It is important to recognize the unique characteristics of isothermal enclosures. See Fig. 12.11 to identify them.

### PROBLEM 12.25

**KNOWN:** Sun has equivalent blackbody temperature of 5800 K. Diameters of sun and earth as well as separation distance are prescribed.

**FIND:** Temperature of the earth assuming the earth is black.

**SCHEMATIC:**

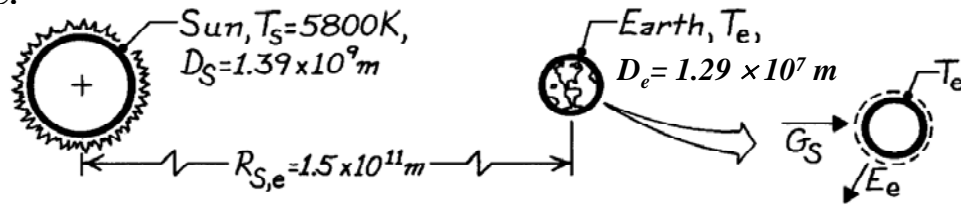

**ASSUMPTIONS:** (1) Sun and earth emit as blackbodies, (2) No attenuation of solar irradiation enroute to earth, and (3) Earth atmosphere has no effect on earth energy balance.

**ANALYSIS:** Performing an energy balance on the earth,

$$\begin{aligned} \dot{E}_{in} - \dot{E}_{out} &= 0 \\ A_{e,p} \cdot G_S &= A_{e,s} \cdot E_b(T_e) \\ \left(\pi D_e^2 / 4\right) G_S &= \pi D_e^2 \sigma T_e^4 \\ T_e &= (G_S / 4\sigma)^{1/4} \end{aligned}$$

where  $A_{e,p}$  and  $A_{e,s}$  are the projected area and total surface area of the earth, respectively. To determine the irradiation  $G_S$  at the earth's surface, equate the rate of emission from the sun to the rate at which this radiation passes through a spherical surface of radius  $R_{S,e} - D_e/2$ .

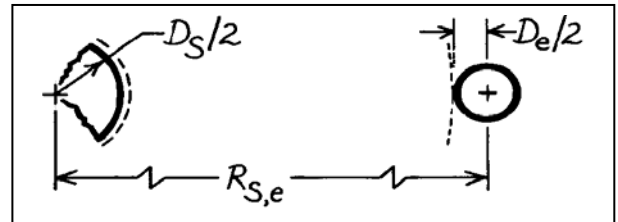

$$\begin{aligned} \dot{E}_{in} - \dot{E}_{out} &= 0 \\ \pi D_S^2 \cdot \sigma T_S^4 &= 4\pi [R_{S,e} - D_e/2]^2 G_S \\ \pi (1.39 \times 10^9 \text{ m})^2 \times 5.67 \times 10^{-8} \text{ W/m}^2 \cdot \text{K}^4 (5800 \text{ K})^4 &= 4\pi [1.5 \times 10^{11} - 1.27 \times 10^7 / 2]^2 \text{ m}^2 \times G_S \\ G_S &= 1377.5 \text{ W/m}^2. \end{aligned}$$

Substituting numerical values, find

$$T_e = \left(1377.5 \text{ W/m}^2 / 4 \times 5.67 \times 10^{-8} \text{ W/m}^2 \cdot \text{K}^4\right)^{1/4} = 279 \text{ K.} \quad <$$

**COMMENTS:** (1) The average earth's temperature is greater than 279 K since the effect of the atmosphere is to reduce the heat loss by radiation.

(2) Note carefully the different areas used in the earth energy balance. Emission occurs from the total spherical area, while solar irradiation is absorbed by the projected spherical area.

## PROBLEM 12.26

**KNOWN:** Solar power concentrated into cavity, energy storage rate for salt, salt temperature, cavity opening diameter.

**FIND:** Thermal energy delivered to the Rankine cycle.

**SCHEMATIC:**

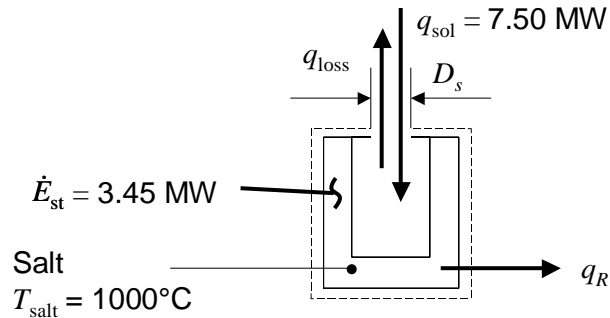

**ASSUMPTIONS:** (1) Temperatures are not changing with time. (2) Negligible irradiation from surroundings and convective losses. (3) Cavity opening area is small relative to cavity surface area.

**ANALYSIS:**

(a) An energy balance on the control volume shown in the schematic yields

$$q_R = q_{sol} - \dot{E}_{st} - q_{loss}$$

where the heat loss through the cavity opening is

$$q_{loss} = \frac{\pi D_s^2}{4} \sigma T_{salt}^4 = \frac{\pi (1 \text{ m})^2}{4} \times 5.67 \times 10^{-8} \text{ W/m}^2 \cdot \text{K}^4 \times (1000 + 273 \text{ K})^4 = 117,000 \text{ W} = 0.12 \text{ MW}$$

Hence the heat transfer to the Rankine cycle is

$$q_R = 7.50 - 3.45 - 0.12 = 3.93 \text{ MW}$$

<

**COMMENTS:** (1) The radiation heat loss through the cavity opening is relatively small, but could be reduced further by decreasing the size of the cavity opening. Reducing the size of the opening would require more expensive heliostats and mirrors in order to more precisely direct the concentrated solar irradiation into the cavity. (2) Convection losses through the cavity opening may be large, necessitating placement of a radiatively-transparent window over the cavity opening.

## PROBLEM 12.27

**KNOWN:** Spectral distribution of the emissive power given by Planck's distribution.

**FIND:** Approximations to the Planck distribution for the extreme cases when (a)  $C_2/\lambda T \gg 1$ , Wien's law and (b)  $C_2/\lambda T \ll 1$ , Rayleigh-Jeans law.

**ANALYSIS:** Planck's distribution provides the spectral, hemispherical emissive power of a blackbody as a function of wavelength and temperature, Eq. 12.30,

$$E_{\lambda,b}(\lambda, T) = C_1 / \lambda^5 [\exp(C_2 / \lambda T) - 1].$$

We now consider the extreme cases of  $C_2/\lambda T \gg 1$  and  $C_2/\lambda T \ll 1$ .

(a) When  $C_2/\lambda T \gg 1$  (or  $\lambda T \ll C_2$ ), it follows  $\exp(C_2/\lambda T) \gg 1$ . Hence, the  $-1$  term in the denominator of the Planck distribution is insignificant, giving

$$E_{\lambda,b}(\lambda, T) \approx (C_1 / \lambda^5) \exp(-C_2 / \lambda T). \quad <$$

This approximate relation is known as *Wien's law*. The ratio of the emissive power by Wien's law to that by the Planck law is,

$$\frac{E_{\lambda,b,Wien}}{E_{\lambda,b,Planck}} = \frac{1/\exp(C_2 / \lambda T)}{1/[\exp(C_2 / \lambda T) - 1]}.$$

For the condition  $\lambda T = \lambda_{max} T = 2898 \mu\text{m}\cdot\text{K}$ ,  $C_2/\lambda T = \frac{14388 \mu\text{m}\cdot\text{K}}{2898 \mu\text{m}\cdot\text{K}} = 4.966$  and

$$\frac{E_{\lambda,b}|_{Wien}}{E_{\lambda,b}|_{Planck}} = \frac{1/\exp(4.966)}{1/[\exp(4.966) - 1]} = 0.9930. \quad <$$

That is, for  $\lambda T \leq 2898 \mu\text{m}\cdot\text{K}$ , Wien's law is a good approximation to the Planck distribution.

(b) If  $C_2/\lambda T \ll 1$  (or  $\lambda T \gg C_2$ ), the exponential term may be expressed as a series that can be approximated by the first two terms. That is,

$$e^x = 1 + x + \frac{x^2}{2!} + \frac{x^3}{3!} + \dots \approx 1 + x \quad \text{when} \quad x \ll 1.$$

The *Rayleigh-Jeans* approximation is then

$$E_{\lambda,b}(\lambda, T) \approx C_1 / \lambda^5 [1 + (C_2 / \lambda T) - 1] = C_1 T / C_2 \lambda^4.$$

For the condition  $\lambda T = 100,000 \mu\text{m}\cdot\text{K}$ ,  $C_2/\lambda T = 0.1439$

$$\frac{E_{\lambda,b,R-J}}{E_{\lambda,b,Planck}} = \frac{C_1 T / C_2 \lambda^4}{C_1 / \lambda^5} [\exp(C_2 / \lambda T) - 1]^{-1} = (\lambda T / C_2) [\exp(C_2 / \lambda T) - 1] = 1.0754. \quad <$$

That is, for  $\lambda T \geq 100,000 \mu\text{m}\cdot\text{K}$ , the Rayleigh-Jeans law is a good approximation (better than 10%) to the Planck distribution.

**COMMENTS:** Wien's law is used extensively in optical pyrometry for values of  $\lambda$  near  $0.65 \mu\text{m}$  and temperatures above  $700 \text{ K}$ . The Rayleigh-Jeans law is of limited use in heat transfer but of utility for far infrared applications.

## PROBLEM 12.28

**KNOWN:** Various surface temperatures.

**FIND:** (a) Wavelength corresponding to maximum emission for each surface, (b) Fraction of solar emission in UV, VIS and IR portions of the spectrum.

**ASSUMPTIONS:** (1) Spectral distribution of emission from each surface is approximately that of a blackbody, (2) The sun emits as a blackbody at 5800 K.

**ANALYSIS:** (a) From Wien's displacement law, Eq. 12.31, the wavelength of maximum emission for blackbody radiation is

$$\lambda_{\max} = \frac{C_3}{T} = \frac{2898 \mu\text{m} \cdot \text{K}}{T}$$

For the prescribed surfaces

Surface	Sun (5800K)	Tungsten (2500K)	Hot metal (1500K)	Skin metal (305K)	Cool metal (60K)	
$\lambda_{\max}(\mu\text{m})$	0.50	1.16	1.93	9.50	48.3	<

(b) From Fig. 12.3, the spectral regions associated with each portion of the spectrum are

Spectrum	Wavelength limits, $\mu\text{m}$
UV	0.01 – 0.4
VIS	0.4 – 0.7
IR	0.7 - 100

For  $T = 5800\text{K}$  and each of the wavelength limits, from Table 12.1 find:

$\lambda(\mu\text{m})$	$10^{-2}$	0.4	0.7	$10^2$
$\lambda T(\mu\text{m} \cdot \text{K})$	58	2320	4060	$5.8 \times 10^5$
$F_{(0 \rightarrow \lambda)}$	0	0.125	0.491	1

Hence, the fraction of the solar emission in each portion of the spectrum is:

$$F_{\text{UV}} = 0.125 - 0 = 0.125 \quad <$$

$$F_{\text{VIS}} = 0.491 - 0.125 = 0.366 \quad <$$

$$F_{\text{IR}} = 1 - 0.491 = 0.509. \quad <$$

**COMMENTS:** (1) Spectral concentration of surface radiation depends strongly on surface temperature. (2) Much of the UV solar radiation is absorbed in the earth's atmosphere.

## PROBLEM 12.29

**KNOWN:** Thermal imagers operating in the spectral regions 3 to 5  $\mu\text{m}$  and 8 to 14  $\mu\text{m}$ .

**FIND:** (a) Band-emission factors for each of the spectral regions, 3 to 5  $\mu\text{m}$  and 8 to 14  $\mu\text{m}$ , for temperatures of 300 and 900 K, (b) Calculate and plot the band-emission factors for each of the spectral regions for the temperature range 300 to 1000 K; identify the maxima, and draw conclusions concerning the choice of an imager for an application; and (c) Considering imagers operating at the maximum-fraction temperatures found from the graph of part (b), determine the sensitivity (%) required of the radiation detector to provide a noise-equivalent temperature (NET) of 5°C.

**ASSUMPTIONS:** The sensitivity of the imager's radiation detector within the operating spectral region is uniform.

**ANALYSIS:** (a) From Eqs. 12.34 and 12.35, the band-emission fraction  $F(\lambda_1 \rightarrow \lambda_2, T)$  for blackbody emission in the spectral range  $\lambda_1$  to  $\lambda_2$  for a temperature T is

$$F(\lambda_1 \rightarrow \lambda_2, T) = F(0 \rightarrow \lambda_2, T) - F(0 \rightarrow \lambda_1, T)$$

Using the *IHT Radiation | Band Emission* tool (or Table 12.1), evaluate  $F(0 \rightarrow \lambda, T)$  at appropriate  $\lambda \cdot T$  products:

*3 to 5  $\mu\text{m}$  region*

$$F(\lambda_1 \rightarrow \lambda_2, 300 \text{ K}) = 0.1375 - 0.00017 = 0.01373 \quad <$$

$$F(\lambda_1 \rightarrow \lambda_2, 900 \text{ K}) = 0.5640 - 0.2055 = 0.3585 \quad <$$

*8 to 14  $\mu\text{m}$  region*

$$F(\lambda_1 \rightarrow \lambda_2, 300 \text{ K}) = 0.5160 - 0.1403 = 0.3757 \quad <$$

$$F(\lambda_1 \rightarrow \lambda_2, 900 \text{ K}) = 0.9511 - 0.8192 = 0.1319 \quad <$$

(b) Using the *IHT Radiation | Band Emission* tool, the band-emission fractions for each of the spectral regions is calculated and plotted below as a function of temperature.

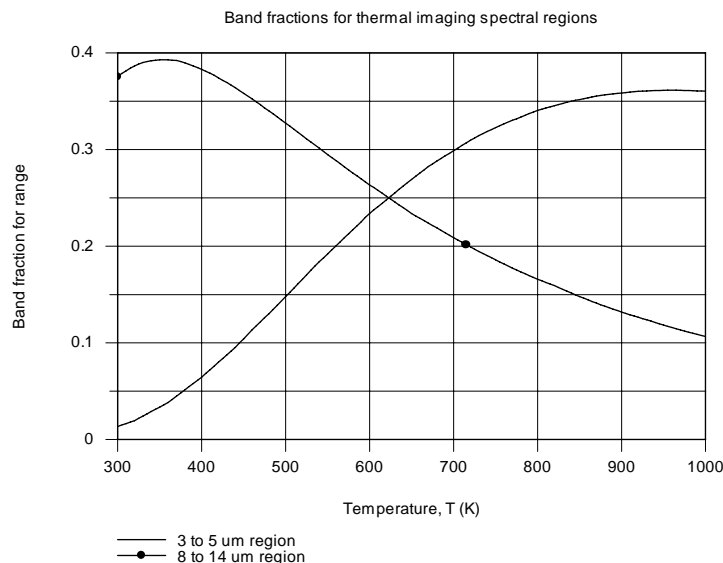

Continued ...

### PROBLEM 12.29 (Cont.)

For the 3 to 5  $\mu\text{m}$  imager, the band-emission factor increases with increasing temperature. For low temperature applications, not only is the radiant power ( $\sigma T^4$ ,  $T \approx 300 \text{ K}$ ) low, but the band fraction is small. However, for high temperature applications, the imager operating conditions are more favorable with a large band-emission factor, as well as much higher radiant power ( $\sigma T^4$ ,  $T \rightarrow 900 \text{ K}$ ).

For the 8 to 14  $\mu\text{m}$  imager, the band-emission factor decreases with increasing temperature. This is a more favorable instrumentation feature, since the band-emission factor (proportionally more power) becomes larger as the radiant power decreases. This imager would be preferred over the 3 to 5  $\mu\text{m}$  imager at lower temperatures since the band-emission factor is 8 to 10 times higher.

Recognizing that from Wien's displacement law, the peaks of the blackbody curves for 300 and 900 K are approximately 10 and 3.3  $\mu\text{m}$ , respectively, it follows that the imagers will receive the most radiant power when the peak target spectral distributions are close to the operating spectral region. It is good application practice to choose an imager having a spectral operating range close to the peak of the blackbody curve (or shorter than, if possible) corresponding to the target temperature.

The maxima band fractions for the 3 to 5  $\mu\text{m}$  and 8 to 14  $\mu\text{m}$  spectral regions correspond to temperatures of 960 and 355 K, respectively. Other application factors not considered (like smoke, water vapor, etc), the former imager is better suited with higher temperature scenes, and the latter with lower temperature scenes.

(c) Consider the 3 to 5  $\mu\text{m}$  and 8 to 14  $\mu\text{m}$  imagers operating at their band-emission peak temperatures, 355 and 960 K, respectively. The sensitivity  $S$  (% units) of the imager to resolve an NET of  $5^\circ\text{C}$  can be expressed as

$$S(\%) = \frac{F(\lambda_1 - \lambda_2, T_1) - F(\lambda_1 - \lambda_2, T_2)}{F(\lambda_1 - \lambda_2, T_1)} \times 100$$

where  $T_1 = 355$  or  $960 \text{ K}$  and  $T_2 = 360$  or  $965 \text{ K}$ , respectively. Using this relation in the *IHT* workspace, find

$$S_{3-5} = 0.035\%$$

$$S_{8-14} = 0.023\%$$

<

That is, we require the radiation detector (with its signal-processing system) to resolve the output signal with the foregoing precision in order to indicate a  $5^\circ\text{C}$  change in the scene temperature.



### PROBLEM 12.30

**KNOWN:** Tube furnace maintained at  $T_f = 2000$  K used to calibrate a heat flux gage of sensitive area  $5 \text{ mm}^2$  mounted coaxial with the furnace centerline, and positioned  $60 \text{ mm}$  from the opening of the furnace.

**FIND:** (a) Heat flux ( $\text{kW/m}^2$ ) on the gage, (b) Radiant flux in the spectral region  $0.4$  to  $2.5 \mu\text{m}$ , the sensitive spectral region of a solid-state (photoconductive type) heat-flux gage, and (c) Calculate and plot the heat fluxes for each of the gages as a function of the furnace temperature for the range  $2000 \leq T_f \leq 3000$  K. Compare the values for the two types of gages; explain why the solid-state gage will always indicate systematically low values; does the solid-state gage performance improve, or become worse as the source temperature increases?

**SCHEMATIC:**

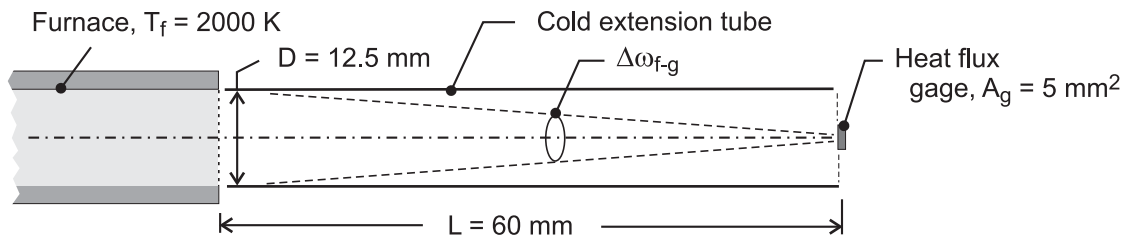

**ASSUMPTIONS:** (1) Steady-state conditions, (2) Graphite tube furnace behaves as a blackbody, (3) Areas of gage and furnace opening are small relative to separation distance squared, and (4) Extension tube is cold relative to the furnace.

**ANALYSIS:** (a) The heat flux to the gage is equal to the irradiation,  $G_g$ , on the gage and can be expressed as (see Section 12.3.3)

$$G_g = I_f \cdot \cos \theta_g \cdot \Delta\omega_{f-g}$$

where  $\Delta\omega_{f-g}$  is the solid angle that the furnace opening subtends relative to the gage. From Eq. 12.7, with  $\theta_g = 0^\circ$

$$\Delta\omega_{f-g} \equiv \frac{dA_n}{r^2} = \frac{A_f \cos \theta_g}{L^2} = \frac{\pi(0.0125 \text{ m})^2 / 4 \times 1}{(0.060 \text{ m})^2} = 3.409 \times 10^{-2} \text{ sr}$$

The intensity of the radiation from the furnace is

$$I_f = E_{b,f}(T_f) / \pi = \sigma T_f^4 / \pi = 5.67 \times 10^{-8} \text{ W/m}^2 \cdot \text{K}^4 (2000 \text{ K})^4 / \pi = 2.888 \times 10^5 \text{ W/m}^2 \cdot \text{sr}$$

Substituting numerical values,

$$G_g = 2.888 \times 10^5 \text{ W/m}^2 \cdot \text{sr} \times 1 \times 3.409 \times 10^{-2} \text{ sr} = 9.84 \text{ kW/m}^2 \quad <$$

(b) The solid-state detector gage, sensitive only in the spectral region  $\lambda_1 = 0.4 \mu\text{m}$  to  $\lambda_2 = 2.5 \mu\text{m}$ , will receive the band irradiation.

$$G_{g, \lambda_1-\lambda_2} = F(\lambda_1 \rightarrow \lambda_2, T_f) \cdot G_{g,b} = \left[ F(0 \rightarrow \lambda_2, T_f) - F(0 \rightarrow \lambda_1, T_f) \right] G_{g,b}$$

Continued ...

### PROBLEM 12.30 (Cont.)

where for  $\lambda_1 T_f = 0.4 \mu\text{m} \times 2000 \text{ K} = 800 \mu\text{m}\cdot\text{K}$ ,  $F_{(0-\lambda_1)} = 0.0000$  and for  $\lambda_2 \cdot T_f = 2.5 \mu\text{m} \times 2000 \text{ K} = 5000 \mu\text{m}\cdot\text{K}$ ,  $F_{(0-\lambda_2)} = 0.6337$ . Hence,

$$G_{g,\lambda_1-\lambda_2} = [0.6337 - 0.0000] \times 9.84 \text{ kW} / \text{m}^2 = 6.24 \text{ kW} / \text{m}^2 \quad <$$

(c) Using the foregoing equation in the *IHT* workspace, the heat fluxes for each of the gage types are calculated and plotted as a function of the furnace temperature.

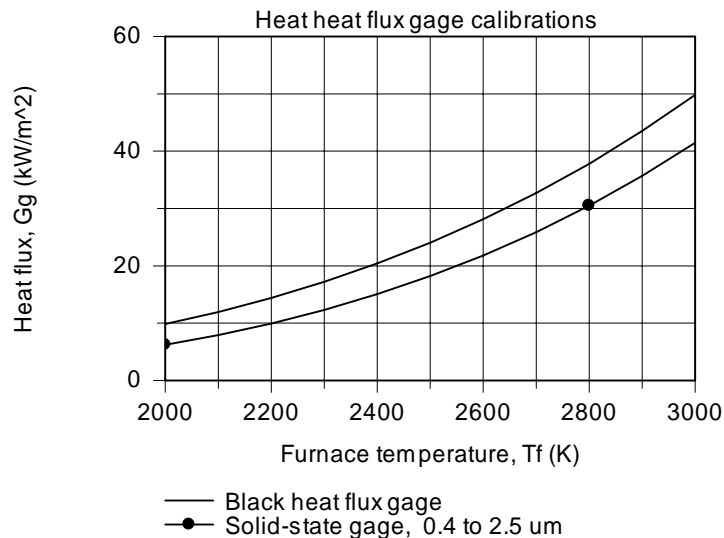

For the black gage, the irradiation received by the gage,  $G_g$ , increases as the fourth power of the furnace temperature. For the solid-state gage, the irradiation increases slightly greater than the fourth power of the furnace temperature since the band-emission factor for the spectral region,  $F_{(\lambda_1 - \lambda_2, T_f)}$ , increases with increasing temperature. The solid-state gage will always indicate systematic low readings since its band-emission factor never approaches unity. However, the error will decrease with increasing temperature as a consequence of the corresponding increase in the band-emission factor.

**COMMENTS:** For this furnace-gage geometrical arrangement, evaluating the solid angle,  $\Delta\omega_{f-g}$ , and the areas on a differential basis leads to results that are systematically high by 1%. Using the view factor concept introduced in Chapter 13, the results for the black and solid-state gages are 9.74 and 6.17  $\text{kW}/\text{m}^2$ , respectively.

### PROBLEM 12.31

**KNOWN:** Bandgap of photovoltaic material. Relationship between wavelength and energy state of photon. Inter-band gap efficiency. Half of incident photons not converted to electricity are absorbed as thermal energy. Solar irradiation and associated blackbody temperature.

**FIND:** Wavelengths of solar irradiation corresponding to material's band gap. Overall efficiency. Heat absorption per unit surface area.

**SCHEMATIC:**

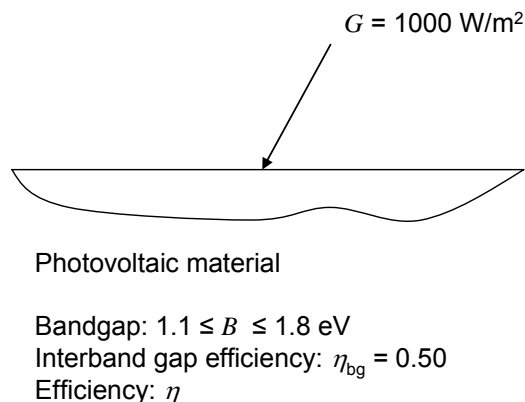

**ASSUMPTIONS:** Wavelength distribution of solar irradiation corresponds to a blackbody at 5800 K.

**ANALYSIS:** The lower boundary of the band-gap,  $B = 1.1$  eV, corresponds to a wavelength of

$$\lambda_2 = \frac{1240 \text{ eV} \cdot \text{nm}}{B} = \frac{1240 \text{ eV} \cdot \text{nm}}{1.1 \text{ eV}} = 1127 \text{ nm} = 1.127 \mu\text{m}$$

Similarly, the upper boundary,  $B = 1.8$  eV, corresponds to  $\lambda_1 = 0.689 \mu\text{m}$ . Thus, the wavelength range corresponding to the band gap is

$$0.689 \mu\text{m} \leq \lambda \leq 1.127 \mu\text{m} \quad \leftarrow$$

The fraction of the irradiation that falls in this wavelength range can be found from Table 12.1. With  $T = 5800$  K,  $\lambda_1 T = 0.689 \mu\text{m} \times 5800 \text{ K} = 4000 \mu\text{m} \cdot \text{K}$ ,  $\lambda_2 T = 6540 \mu\text{m} \cdot \text{K}$ , thus

$$F_{(\lambda_1 \rightarrow \lambda_2)} = F_{(0 \rightarrow \lambda_2)} - F_{(0 \rightarrow \lambda_1)} = 0.7647 - 0.4809 = 0.2838$$

Hence the overall efficiency is

$$\eta = \eta_{bg} F_{bg} = 0.50 \times 0.2838 = 0.1419 \quad \leftarrow$$

If half of the irradiation that is *not* converted to electricity is absorbed as thermal energy, then the fraction absorbed is  $0.5 \times (1 - 0.1419) = 0.4290$ . Thus, the absorbed energy is

$$q = 0.4290 \times 1000 \text{ W/m}^2 = 429 \text{ W/m}^2 \quad \leftarrow$$

**COMMENT:** The irradiation that is neither converted to electricity nor converted to thermal energy is reflected from or transmitted through the material.

### PROBLEM 12.32

**KNOWN:** Geometry and temperature of a ring-shaped radiator. Area of irradiated part and distance from radiator.

**FIND:** Rate at which radiant energy is incident on the part.

**SCHEMATIC:**

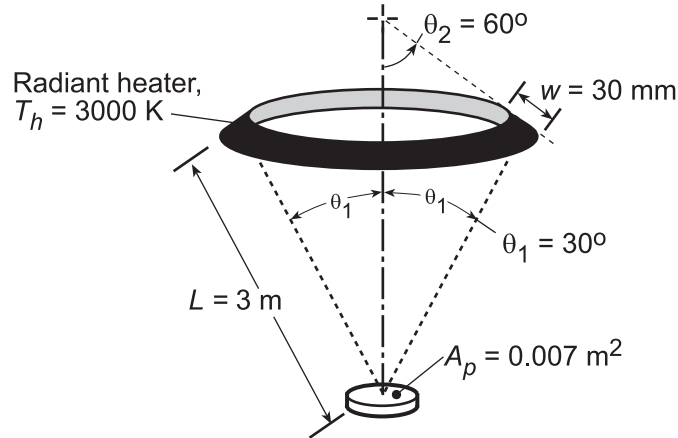

**ASSUMPTIONS:** (1) Heater emits as a blackbody.

**ANALYSIS:** Expressing Eq. 12.12 on the basis of the total radiation,  $dq = I_e dA_h \cos\theta d\omega$ , the rate at which radiation is incident on the part is

$$q_{h-p} = \int dq = I_e \iint \cos\theta d\omega_{p-h} dA_h \approx I_e \cos\theta \cdot \omega_{p-h} \cdot A_h$$

Since radiation leaving the heater in the direction of the part is oriented normal to the heater surface,  $\theta = 0$  and  $\cos\theta = 1$ . The solid angle subtended by the part with respect to the heater is  $\omega_{p-h} = A_p \cos\theta_1 / L^2$ , while the area of the heater is  $A_h \approx 2\pi r_h W = 2\pi(L \sin\theta_1)W$ . Hence, with  $I_e = E_b / \pi = \sigma T_h^4 / \pi$ ,

$$q_{h-p} \approx \frac{5.67 \times 10^{-8} \text{ W/m}^2 \cdot \text{K}^4 (3000 \text{ K})^4}{\pi} \times \frac{0.007 \text{ m}^2 (\cos 30^\circ)}{(3 \text{ m})^2} \times 2\pi (1.5 \text{ m}) 0.03 \text{ m}$$

$$q_{h-p} \approx 278.4 \text{ W}$$

<

**COMMENTS:** The foregoing representation for the double integral is an excellent approximation since  $W \ll L$  and  $A_p \ll L^2$ .

### PROBLEM 12.33

**KNOWN:** Aperture of an isothermal furnace emits as a blackbody.

**FIND:** (a) An expression for the ratio of the fractional change in the spectral intensity to the fractional change in temperature of the furnace aperture, (b) Allowable variation in temperature of a furnace operating at 2000 K such that the spectral intensity at 0.65 μm will not vary by more than 1/2%. Allowable variation for 10 μm.

**SCHEMATIC:**

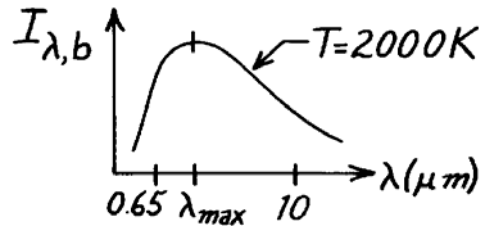

**ASSUMPTIONS:** (1) Furnace is isothermal and aperture radiates as a blackbody.

**ANALYSIS:** (a) The Planck spectral distribution, Eq. 12.30, is

$$I_{\lambda}(\lambda, T) = C_1 / \pi \lambda^5 \left[ \exp(C_2 / \lambda T) - 1 \right].$$

Taking natural logarithms of both sides, find  $\ln I_{\lambda} = \ln \left[ C_1 / \pi \lambda^5 \right] - \ln \left[ \exp(C_2 / \lambda T) - 1 \right]$ . Take the total derivative of both sides, but consider the  $\lambda$  variable as a constant.

$$\frac{dI_{\lambda}}{I_{\lambda}} = \frac{d \left[ \exp(C_2 / \lambda T) - 1 \right]}{\left[ \exp(C_2 / \lambda T) - 1 \right]} = \frac{\left\{ \exp(C_2 / \lambda T) \right\} (C_2 / \lambda) (-1/T^2) dT}{\left[ \exp(C_2 / \lambda T) - 1 \right]}$$

$$\frac{dI_{\lambda}}{I_{\lambda}} = \frac{C_2}{\lambda T} \cdot \frac{\exp(C_2 / \lambda T)}{\left[ \exp(C_2 / \lambda T) - 1 \right]} \cdot \frac{dT}{T} \quad \text{or} \quad \frac{dI_{\lambda} / I_{\lambda}}{dT / T} = \frac{C_2}{\lambda T} \cdot \frac{1}{1 - \exp(-C_2 / \lambda T)} \quad <$$

(b) If the furnace operates at 2000 K and the desirable fractional change of the spectral intensity is 0.5% at 0.65 μm, the allowable temperature variation is

$$\frac{dT}{T} = \frac{dI_{\lambda}}{I_{\lambda}} / \left\{ \frac{C_2}{\lambda T} \frac{1}{1 - \exp(-C_2 / \lambda T)} \right\}$$

$$\frac{dT}{T} = 0.005 / \left\{ \frac{14,388 \mu\text{m} \cdot \text{K}}{0.65 \mu\text{m} \times 2000 \text{K}} / \left[ 1 - \exp \left( \frac{-14,388 \mu\text{m} \cdot \text{K}}{0.65 \mu\text{m} \times 2000 \text{K}} \right) \right] \right\} = 4.517 \times 10^{-4}.$$

That is, the allowable fractional variation in temperature is 0.045%; at 2000 K, the allowable temperature variation is

$$\Delta T \approx 4.517 \times 10^{-4} T = 4.517 \times 10^{-4} \times 2000 \text{K} = 0.90 \text{K}. \quad <$$

Substituting with  $T = 2000 \text{K}$  and  $\lambda = 10 \mu\text{m}$ , find that

$$\frac{dT}{T} = 3.565 \times 10^{-3} \quad \text{and} \quad \Delta T \approx 3.565 \times 10^{-3} T = 7.1 \text{K}. \quad <$$

**COMMENTS:** Note that the power control requirements to satisfy the spectral intensity variation for 0.65 μm and 10 μm conditions are quite different. The peak of the blackbody curve for 2000 K is  $\lambda_{\text{max}} = 2898 \mu\text{m} \cdot \text{K} / 2000 \text{K} = 1.45 \mu\text{m}$ .

### PROBLEM 12.34

**KNOWN:** Variation of spectral, hemispherical emissivity with wavelength for two materials.

**FIND:** Nature of the variation with temperature of the total, hemispherical emissivity.

**SCHEMATIC:**

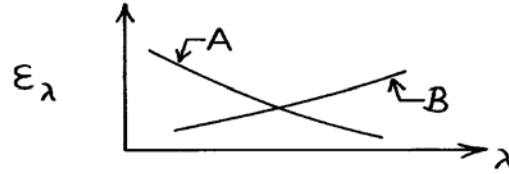

**ASSUMPTIONS:** (1)  $\epsilon_\lambda$  is independent of temperature.

**ANALYSIS:** The total, hemispherical emissivity may be obtained from knowledge of the spectral, hemispherical emissivity by using Eq. 12.43

$$\epsilon(T) = \frac{\int_0^\infty \epsilon_\lambda(\lambda) E_{\lambda,b}(\lambda, T) d\lambda}{E_b(T)} = \int_0^\infty \epsilon_\lambda(\lambda) \frac{E_{\lambda,b}(\lambda, T)}{E_b(T)} d\lambda.$$

We also know that the spectral emissive power of a blackbody becomes more concentrated at lower wavelengths with increasing temperature (Fig. 12.12). That is, the weighting factor,  $E_{\lambda,b}(\lambda, T)/E_b(T)$  increases at lower wavelengths and decreases at longer wavelengths with increasing  $T$ . Accordingly,

*Material A:*  $\epsilon(T)$  increases with increasing  $T$  <

*Material B:*  $\epsilon(T)$  decreases with increasing  $T$ . <

### PROBLEM 12.35

**KNOWN:** Initial and final object temperature. Variation of spectral emissivity with wavelength for two coatings.

**FIND:** Which coating cools faster.

**SCHEMATIC:**

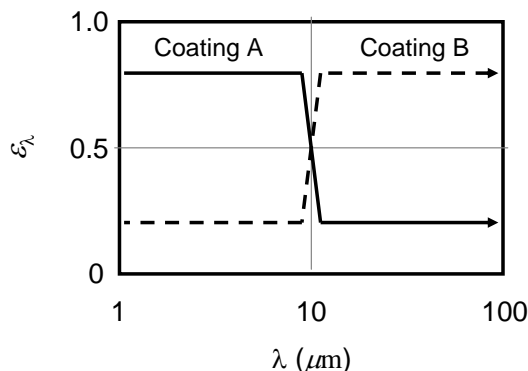

**ASSUMPTIONS:** (1) Surface is a diffuse emitter, (2) Negligible radiation from low-temperature vacuum chamber to object, (3) The spectral emissivity distribution can be approximated as a step change.

**ANALYSIS:** The object cools by radiation to the surroundings, and the object will cool faster if its emissivity is greater. The total, hemispherical emissivity is given by Equation 12.43, and changes with time as the temperature of the object changes. From Equation 12.43,

$$\begin{aligned}\varepsilon(T) &= \frac{\int_0^{\infty} \varepsilon_{\lambda} E_{\lambda,b} d\lambda}{E_b(T)} = \frac{\varepsilon_1 \int_0^{\lambda_c} E_{\lambda,b} d\lambda + \varepsilon_2 \int_{\lambda_c}^{\infty} E_{\lambda,b} d\lambda}{E_b(T)} \\ &= \varepsilon_1 F_{(0 \rightarrow \lambda_c)} + \varepsilon_2 (1 - F_{(0 \rightarrow \lambda_c)})\end{aligned}$$

where  $\lambda_c = 10 \mu\text{m}$  is the cut-off wavelength at which the emissivity changes from  $\varepsilon_1$  to  $\varepsilon_2$ . For coating A,  $\varepsilon_1$  is the higher value and  $\varepsilon_2$  is the lower value, and vice versa for coating B. At the initial temperature of 1000 K, we find  $\lambda_c T = 10,000 \mu\text{m}\cdot\text{K}$ , and from Table 12.1,  $F_{(0 \rightarrow \lambda_c)} = 0.914$ . Therefore coating A has the higher emissivity value over 91.4% of the spectrum and has the higher total emissivity. At the final temperature of 500 K, we find  $\lambda_c T = 5000 \mu\text{m}\cdot\text{K}$ , and from Table 12.1,  $F_{(0 \rightarrow \lambda_c)} = 0.0634$ . Thus, coating A still has the higher emissivity value.

Coating A will cause the object to cool faster. <

**COMMENTS:** The emissivity of coatings A and B are the same when  $F_{(0 \rightarrow \lambda_c)} = 0.5$ . From Table 12.1, this occurs at a temperature of  $T = 411 \text{ K}$ . Below this temperature, coating B will cause faster cooling than coating A. If the object were to be cooled below 411 K, a more complex analysis would be required to determine which coating would lead to the fastest cooling over the entire time period.

### PROBLEM 12.36

**KNOWN:** The total directional emissivity of non-metallic materials may be approximated as  $\varepsilon_\theta = \varepsilon_n \cos \theta$  where  $\varepsilon_n$  is the total normal emissivity.

**FIND:** Show that for such materials, the total hemispherical emissivity,  $\varepsilon$ , is 2/3 the total normal emissivity.

**SCHEMATIC:**

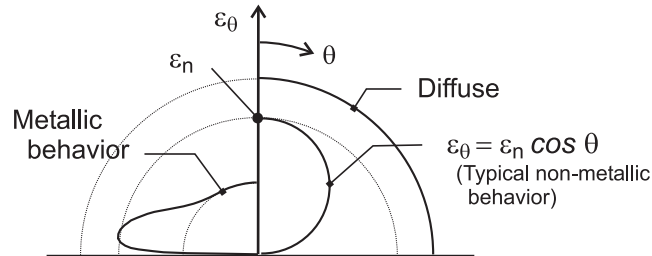

**ANALYSIS:** From Eq. 12.42, written on a total rather than spectral basis, the hemispherical emissivity  $\varepsilon$  can be determined from the directional emissivity  $\varepsilon_\theta$  as

$$\varepsilon = 2 \int_0^{\pi/2} \varepsilon_\theta \cos \theta \sin \theta d\theta$$

With  $\varepsilon_\theta = \varepsilon_n \cos \theta$ , find

$$\varepsilon = 2 \varepsilon_n \int_0^{\pi/2} \cos^2 \theta \sin \theta d\theta$$

$$\varepsilon = -2 \varepsilon_n \left( \cos^3 \theta / 3 \right) \Big|_0^{\pi/2} = 2/3 \varepsilon_n$$

<

**COMMENTS:** (1) Refer to Fig. 12.16 illustrating on cartesian coordinates representative directional distributions of the total, directional emissivity for nonmetallic and metallic materials. In the schematic above, we've shown  $\varepsilon_\theta$  vs.  $\theta$  on a polar plot for both types of materials, in comparison with a diffuse surface.

(2) See Section 12.5 for discussion on other characteristics of emissivity for materials.



### PROBLEM 12.37

**KNOWN:** Metallic surface with prescribed spectral, directional emissivity at 2000 K and 1  $\mu\text{m}$  (see Example 12.7) and additional measurements of the spectral, hemispherical emissivity.

**FIND:** (a) Total hemispherical emissivity,  $\epsilon$ , and the emissive power,  $E$ , at 2000 K, (b) Effect of temperature on the emissivity.

**SCHEMATIC:**

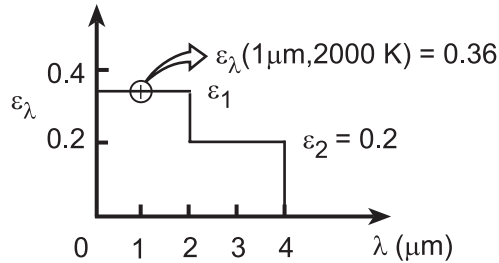

**ANALYSIS:** (a) The total, hemispherical emissivity,  $\epsilon$ , may be determined from knowledge of the spectral, hemispherical emissivity,  $\epsilon_\lambda$ , using Eq. 12.43.

$$\epsilon(T) = \int_0^\infty \epsilon_\lambda(\lambda) E_{\lambda,b}(\lambda, T) d\lambda / E_b(T) = \epsilon_1 \int_0^{2\mu\text{m}} \frac{E_{\lambda,b}(\lambda, T) d\lambda}{E_b(T)} + \epsilon_2 \int_{2\mu\text{m}}^{4\mu\text{m}} \frac{E_{\lambda,b}(\lambda, T) d\lambda}{E_b(T)}$$

or from Eq. 12.34,

$$\epsilon(T) = \epsilon_1 F_{(0 \rightarrow \lambda_1)} + \epsilon_2 [F_{(0 \rightarrow \lambda_2)} - F_{(0 \rightarrow \lambda_1)}]$$

From Table 12.1,

$$\lambda_1 = 2 \mu\text{m}, \quad T = 2000 \text{ K}: \quad \lambda_1 T = 4000 \mu\text{m} \cdot \text{K}, \quad F_{(0 \rightarrow \lambda_1)} = 0.481$$

$$\lambda_2 = 4 \mu\text{m}, \quad T = 2000 \text{ K}: \quad \lambda_2 T = 8000 \mu\text{m} \cdot \text{K}, \quad F_{(0 \rightarrow \lambda_2)} = 0.856$$

Hence,

$$\epsilon(T) = 0.36 \times 0.481 + 0.20(0.856 - 0.481) = 0.25 \quad <$$

The total emissive power at 2000 K is

$$E(2000 \text{ K}) = \epsilon(2000 \text{ K}) \cdot E_b(2000 \text{ K})$$

$$E(2000 \text{ K}) = 0.25 \times 5.67 \times 10^{-8} \text{ W/m}^2 \cdot \text{K}^4 \times (2000 \text{ K})^4 = 2.27 \times 10^5 \text{ W/m}^2. \quad <$$

(b) Using the *Radiation Toolpad* of IHT, the following result was generated.

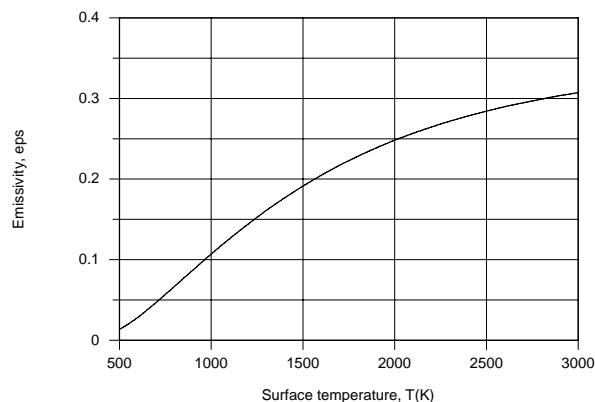

Continued...

### PROBLEM 12.37 (Cont.)

At  $T \approx 500$  K, most of the radiation is emitted in the far infrared region ( $\lambda > 4 \mu\text{m}$ ), in which case  $\varepsilon \approx 0$ . With increasing  $T$ , emission is shifted to lower wavelengths, causing  $\varepsilon$  to increase. As  $T \rightarrow \infty$ ,  $\varepsilon \rightarrow 0.36$ .

**COMMENTS:** Note that the value of  $\varepsilon_\lambda$  for  $0 < \lambda \leq 2 \mu\text{m}$  cannot be read directly from the  $\varepsilon_\lambda$  distribution provided in the problem statement. This value is calculated from knowledge of  $\varepsilon_{\lambda,\theta}(\theta)$  in Example 12.7.

### PROBLEM 12.38

**KNOWN:** Expression for spectral emissivity of titanium at room temperature.

**FIND:** (a) Emissive power of titanium surface at 300 K. (b) Value of  $\lambda_{\max}$  for emissive power of surface in part (a).

**SCHEMATIC:**

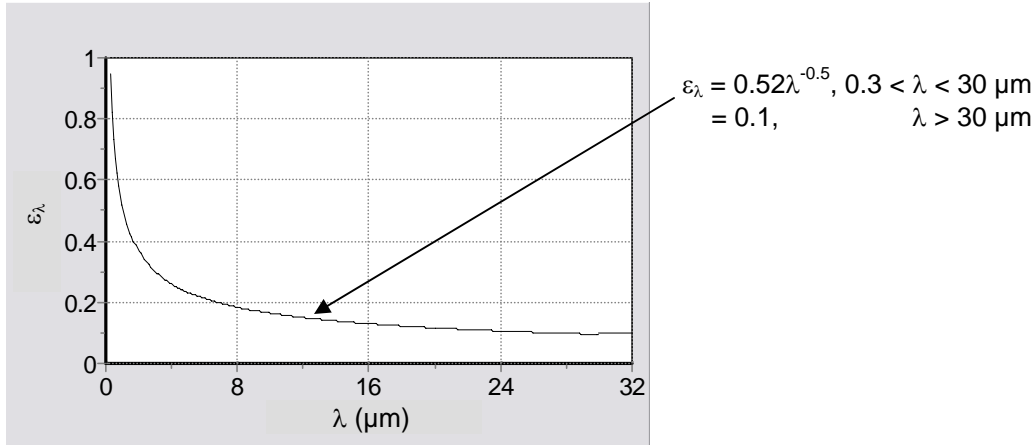

**ANALYSIS:** (a) Combining Eqs. 12.40 and 12.43, the emissive power is given by

$$E(T) = \varepsilon(T)E_b(T) = \int_0^{\infty} \varepsilon_{\lambda}(\lambda, T)E_{\lambda, b}(\lambda, T)d\lambda = I_1 + I_2 + I_3$$

where

$$I_1 = \int_0^{0.3 \mu\text{m}} \varepsilon_{\lambda}(\lambda, T)E_{\lambda, b}(\lambda, T)d\lambda \leq \int_0^{0.3 \mu\text{m}} E_{\lambda, b}(\lambda, T)d\lambda = F_{(0 \rightarrow 0.3 \mu\text{m})}E_b(T)$$

$$I_2 = 0.52 \int_{0.3 \mu\text{m}}^{30 \mu\text{m}} \lambda^{-0.5} E_{\lambda, b}(\lambda, T)d\lambda$$

$$I_3 = 0.1 \int_{30 \mu\text{m}}^{\infty} E_{\lambda, b}(\lambda, T)d\lambda = 0.1F_{(30 \mu\text{m} \rightarrow \infty)}E_b(T)$$

From Table 12.1, with  $\lambda_1 T = 0.3 \mu\text{m} \times 300 \text{ K} = 90 \mu\text{m} \cdot \text{K}$  and  $\lambda_2 T = 30 \mu\text{m} \times 300 \text{ K} = 9000 \mu\text{m} \cdot \text{K}$ ,

$$F_{(0 \rightarrow 0.3 \mu\text{m})} \approx 0$$

$$F_{(30 \mu\text{m} \rightarrow \infty)} = 1 - F_{(0 \rightarrow 30 \mu\text{m})} = 1 - 0.890029 = 0.110$$

Thus

$$I_1 \approx 0$$

$$I_3 = 0.1 \times 0.110 \times 5.67 \times 10^{-8} \text{ W/m}^2 \cdot \text{K}^4 \times (300 \text{ K})^4 = 5.05 \text{ W/m}^2$$

The integral  $I_2$  must be evaluated numerically. Making use of Eq. 12.30 for  $E_{\lambda, b}$ ,

$$I_2 = 0.52 \int_{0.3 \mu\text{m}}^{30 \mu\text{m}} \lambda^{-0.5} \frac{C_1}{\lambda^5 [\exp(C_2/\lambda T) - 1]} d\lambda$$

Continued...

### PROBLEM 12.38 (Cont.)

This integral can be evaluated using the INTEGRAL function of IHT. The result is  $I_2 = 61.16 \text{ W/m}^2$ . Thus,

$$E(T) = I_1 + I_2 + I_3 = 0 + 61.16 \text{ W/m}^2 + 5.05 \text{ W/m}^2 = 66.2 \text{ W/m}^2 \quad <$$

(b) The value of  $\lambda_{\max}$  is the value of  $\lambda$  for which  $E_\lambda$  is maximum. The maximum in  $E_{\lambda,b}$  occurs for  $\lambda_{\max}T = 2898 \mu\text{m}\cdot\text{K}$ , or at 300 K,  $\lambda_{\max} = 9.66 \mu\text{m}$ . However, for  $E_\lambda = \varepsilon_\lambda E_{\lambda,b}$ , the maximum will be shifted because of the dependence of  $\varepsilon_\lambda$  on  $\lambda$ . We consider

$$\frac{dE_\lambda}{d\lambda} = \frac{d(\varepsilon_\lambda E_{\lambda,b})}{d\lambda} = \varepsilon_\lambda \frac{dE_{\lambda,b}}{d\lambda} + \frac{d\varepsilon_\lambda}{d\lambda} E_{\lambda,b} = 0$$

Considering the range  $0.3 \mu\text{m} \leq \lambda \leq 30 \mu\text{m}$ , for which  $\varepsilon_\lambda = 0.52\lambda^{-0.5}$ , this becomes

$$\begin{aligned} 0.52\lambda^{-0.5} \frac{dE_{\lambda,b}}{d\lambda} - 0.5(0.52\lambda^{-1.5})E_{\lambda,b} &= 0 \\ \lambda \frac{dE_{\lambda,b}}{d\lambda} - 0.5E_{\lambda,b} &= 0 \end{aligned} \quad (1)$$

Then

$$\begin{aligned} \frac{dE_{\lambda,b}}{d\lambda} &= \frac{-5C_1}{\lambda^6 [\exp(C_2/\lambda T) - 1]} + \frac{-C_1 \exp(C_2/\lambda T)}{\lambda^5 [\exp(C_2/\lambda T) - 1]^2} \left( -\frac{C_2}{\lambda^2 T} \right) \\ \frac{dE_{\lambda,b}}{d\lambda} &= -5 \frac{E_{\lambda,b}}{\lambda} + \frac{E_{\lambda,b} \exp(C_2/\lambda T)}{[\exp(C_2/\lambda T) - 1]} \left( \frac{C_2}{\lambda^2 T} \right) \end{aligned} \quad (2)$$

Substituting Eq. (2) into Eq. (1) and simplifying,

$$\frac{\exp(C_2/\lambda T)}{[\exp(C_2/\lambda T) - 1]} \left( \frac{C_2}{\lambda T} \right) = 5.5 \quad (3)$$

Solving this implicit equation for  $C_2/\lambda T$  yields

$$\frac{C_2}{\lambda T} = 5.477$$

Thus

$$\lambda_{\max} = \frac{C_2}{5.477T} = \frac{1.439 \times 10^4 \mu\text{m}\cdot\text{K}}{5.477 \times 300 \text{ K}} = 8.76 \mu\text{m} \quad <$$

$E_{\lambda,b}$  will be smaller in the ranges  $\lambda < 0.3 \mu\text{m}$ , and  $\lambda > 30 \mu\text{m}$ .

**COMMENTS:** Because the titanium has an emissivity that increases with decreasing wavelength, the value of  $\lambda_{\max}$  is smaller than would have been predicted with use of Wien's displacement law,  $\lambda_{\max,W} = 2898 \mu\text{m}\cdot\text{K}/300\text{K} = 9.66 \mu\text{m}$ .

### PROBLEM 12.39

**KNOWN:** Spectral directional emissivity of a diffuse material at 2000K.

**FIND:** (a) Total, hemispherical emissivity, (b) Emissive power over the spectral range 0.8 to 2.5  $\mu\text{m}$  and for directions  $0 \leq \theta \leq \pi/6$ .

**SCHEMATIC:**

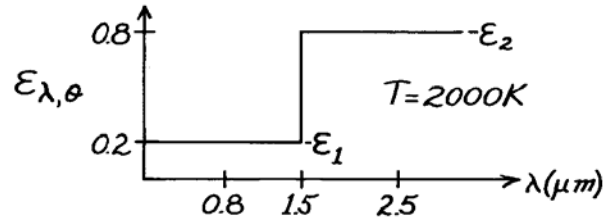

**ASSUMPTIONS:** (1) Surface is diffuse emitter.

**ANALYSIS:** (a) Since the surface is diffuse,  $\varepsilon_{\lambda,\theta}$  is independent of direction; from Eq. 12.42,  $\varepsilon_{\lambda,\theta} = \varepsilon_\lambda$ . Using Eq. 12.43,

$$\varepsilon(T) = \int_0^\infty \varepsilon_\lambda(\lambda) E_{\lambda,b}(\lambda, T) d\lambda / E_b(T)$$

$$E(T) = \int_0^{1.5} \varepsilon_1 E_{\lambda,b}(\lambda, 2000) d\lambda / E_b + \int_{1.5}^\infty \varepsilon_2 E_{\lambda,b}(\lambda, 2000) d\lambda / E_b.$$

Written now in terms of  $F_{(0 \rightarrow \lambda)}$ , with  $F_{(0 \rightarrow 1.5)} = 0.2732$  at  $\lambda T = 1.5 \times 2000 = 3000 \mu\text{m}\cdot\text{K}$ , (Table 12.1) find,

$$\varepsilon(2000 \text{ K}) = \varepsilon_1 \times F_{(0 \rightarrow 1.5)} + \varepsilon_2 [1 - F_{(0 \rightarrow 1.5)}] = 0.2 \times 0.2732 + 0.8 [1 - 0.2732] = 0.636. \quad <$$

(b) For the prescribed spectral and geometric limits, from an equation similar to Eq. 12.15,

$$\Delta E = \int_{0.8}^{2.5} \int_0^{2\pi} \int_0^{\pi/6} \varepsilon_{\lambda,\theta} I_{\lambda,b}(\lambda, T) \cos \theta \sin \theta d\theta d\phi d\lambda$$

where  $I_{\lambda,e}(\lambda, \theta, \phi) = \varepsilon_{\lambda,\theta} I_{\lambda,b}(\lambda, T)$ . Since the surface is diffuse,  $\varepsilon_{\lambda,\theta} = \varepsilon_\lambda$ , and noting  $I_{\lambda,b}$  is independent of direction and equal to  $E_{\lambda,b}/\pi$ , we can write

$$\Delta E = \left\{ \int_0^{2\pi} \int_0^{\pi/6} \cos \theta \sin \theta d\theta d\phi \right\} \frac{E_b(T)}{\pi} \left\{ \frac{\int_{0.8}^{1.5} \varepsilon_1 E_{\lambda,b}(\lambda, T) d\lambda}{E_b(T)} + \frac{\int_{1.5}^{2.5} \varepsilon_2 E_{\lambda,b}(\lambda, T) d\lambda}{E_b(T)} \right\}$$

or in terms  $F_{(0 \rightarrow \lambda)}$  values,

$$\Delta E = \left\{ \phi \left|_0^{2\pi} \times \frac{\sin^2 \theta}{2} \right|_0^{\pi/6} \right\} \frac{\sigma T^4}{\pi} \left\{ \varepsilon_1 [F_{0 \rightarrow 1.5} - F_{0 \rightarrow 0.8}] + \varepsilon_2 [F_{0 \rightarrow 2.5} - F_{0 \rightarrow 1.5}] \right\}.$$

From Table 12.1:  $\lambda T = 0.8 \times 2000 = 1600 \mu\text{m}\cdot\text{K}$   $F_{(0 \rightarrow 0.8)} = 0.0197$

$\lambda T = 2.5 \times 2000 = 5000 \mu\text{m}\cdot\text{K}$   $F_{(0 \rightarrow 2.5)} = 0.6337$

$$\Delta E = \left\{ 2\pi \times \frac{\sin^2 \pi/6}{2} \right\} \frac{5.67 \times 10^{-8} \times 2000^4}{\pi} \frac{\text{W}}{\text{m}^2} \cdot \{0.2 [0.2732 - 0.0197] + 0.8 [0.6337 - 0.2732]\}$$

$$\Delta E = 0.25 \times (5.67 \times 10^{-8} \times 2000^4) \text{ W/m}^2 \times 0.339 = 76.89 \text{ kW/m}^2. \quad <$$

## PROBLEM 12.40

**KNOWN:** Spectral emissivity distribution of diffuse surface. Surface temperature range.

**FIND:** Temperature at which the emissive power is minimized.

**SCHEMATIC:**

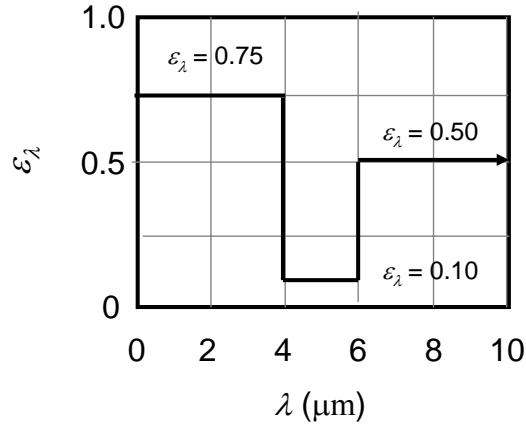

**ASSUMPTIONS:** Surface is a diffuse emitter.

**ANALYSIS:** The emissive power is  $E(T) = \epsilon(T)E_b(T)$ . It is known that  $E_b(T)$  increases with  $T$ , but it is not immediately obvious how  $\epsilon(T)$  varies with temperature since as temperature increases, the heaviest weighting of the spectral emissivity distribution shifts from higher to lower wavelengths. From Eq. 12.43,

$$\begin{aligned} \epsilon(T) &= \frac{\int_0^\infty \epsilon_\lambda E_{\lambda,b} d\lambda}{E_b(T)} = \frac{\epsilon_1 \int_0^{\lambda_1} E_{\lambda,b} d\lambda + \epsilon_2 \int_0^{\lambda_2} E_{\lambda,b} d\lambda + \epsilon_3 \int_0^{\lambda_3} E_{\lambda,b} d\lambda}{E_b(T)} \\ &= \epsilon_1 F_{(0 \rightarrow \lambda_1)} + \epsilon_2 (F_{(0 \rightarrow \lambda_2)} - F_{(0 \rightarrow \lambda_1)}) + \epsilon_3 (1 - F_{(0 \rightarrow \lambda_2)}) \end{aligned}$$

where  $\lambda_1 = 4 \mu\text{m}$ ,  $\lambda_2 = 6 \mu\text{m}$ ,  $\epsilon_1 = 0.75$ ,  $\epsilon_2 = 0.10$ , and  $\epsilon_3 = 0.50$ . At  $T = 300 \text{ K}$ ,

$$\lambda_1 T = 1200 \mu\text{m}\cdot\text{K}, \quad \lambda_2 T = 1800 \mu\text{m}\cdot\text{K}.$$

From Table 12.1,

$$F_{(0 \rightarrow \lambda_1)} = 0.002134, \quad F_{(0 \rightarrow \lambda_2)} = 0.039341.$$

Thus,

$$\epsilon(300 \text{ K}) = 0.75 \times 0.002134 + 0.10 \times (0.039341 - 0.002134) + 0.50 \times (1 - 0.039341) = 0.486$$

and

$$E(300 \text{ K}) = \epsilon(300 \text{ K})\sigma T^4 = 0.486 \times 5.67 \times 10^{-8} \text{ W/m}^2 \cdot \text{K} \times (300 \text{ K})^4 = 223 \text{ W/m}^2$$

Repeating these calculations over the temperature range  $300 \leq T_s \leq 1000 \text{ K}$ , the following plots can be generated.

Continued...

### PROBLEM 12.40 (Cont.)

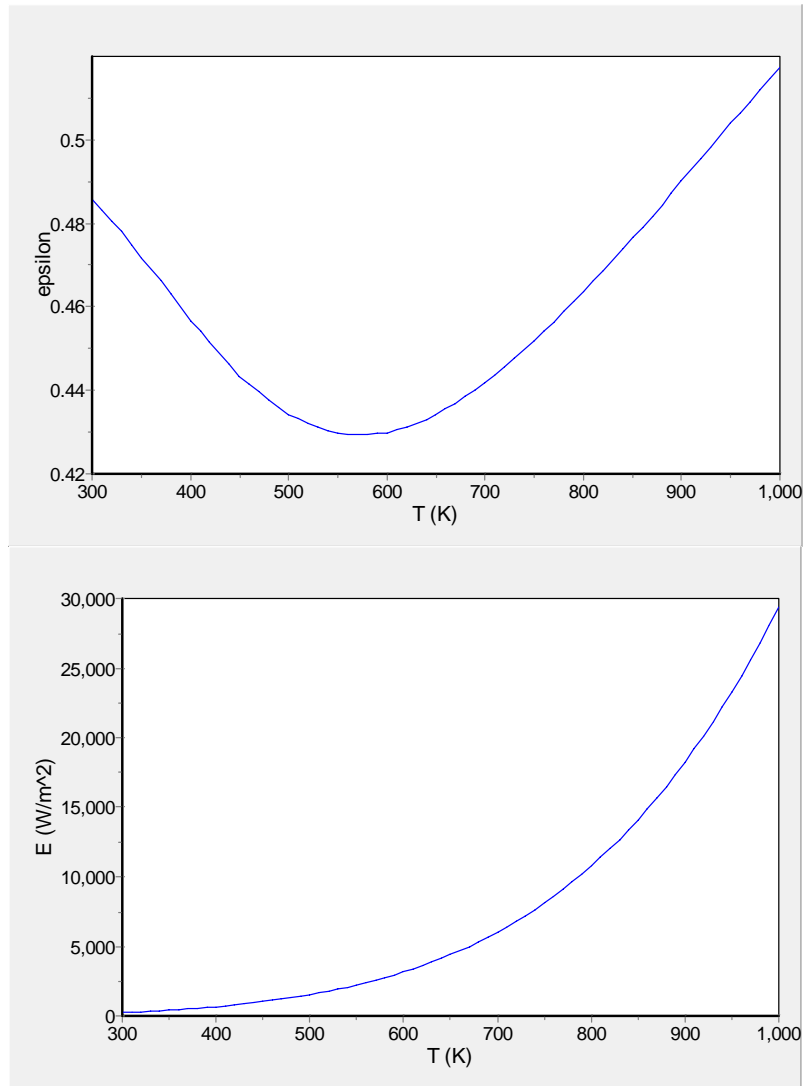

It can be seen that  $\epsilon(T)$  has a minimum around 570 K, however

the minimum value of  $E$  occurs at 300 K

<

and is  $E_{\min} = 223 \text{ W/m}^2$ .

**COMMENTS:** The blackbody emissive power varies as  $T^4$ . The variation of emissivity with temperature is nowhere near as strong and therefore does not give rise to a local minimum in emissive power.

### PROBLEM 12.41

**KNOWN:** Directional emissivity,  $\varepsilon_\theta$ , of a selective surface.

**FIND:** Ratio of the normal emissivity,  $\varepsilon_n$ , to the hemispherical emissivity,  $\varepsilon$ .

**SCHEMATIC:**

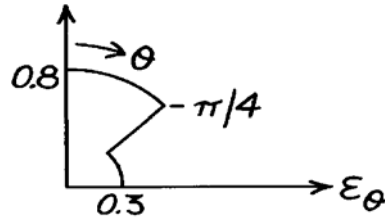

**ASSUMPTIONS:** Surface is isotropic in  $\phi$  direction.

**ANALYSIS:** From Eq. 12.42 written on a total, rather than spectral, basis, the hemispherical emissivity is

$$\varepsilon = 2 \int_0^{\pi/2} \varepsilon_\theta(\theta) \cos \theta \sin \theta d\theta.$$

Recognizing that the integral can be expressed in two parts, find

$$\varepsilon = 2 \left[ \int_0^{\pi/4} \varepsilon_\theta(\theta) \cos \theta \sin \theta d\theta + \int_{\pi/4}^{\pi/2} \varepsilon_\theta(\theta) \cos \theta \sin \theta d\theta \right]$$

$$\varepsilon = 2 \left[ 0.8 \int_0^{\pi/4} \cos \theta \sin \theta d\theta + 0.3 \int_{\pi/4}^{\pi/2} \cos \theta \sin \theta d\theta \right]$$

$$\varepsilon = 2 \left[ 0.8 \frac{\sin^2 \theta}{2} \Big|_0^{\pi/4} + 0.3 \frac{\sin^2 \theta}{2} \Big|_{\pi/4}^{\pi/2} \right]$$

$$\varepsilon = 2 \left[ 0.8 \frac{1}{2} (0.50 - 0) + 0.3 \times \frac{1}{2} (1 - 0.50) \right] = 0.550.$$

The ratio of the normal emissivity ( $\varepsilon_n$ ) to the hemispherical emissivity is

$$\frac{\varepsilon_n}{\varepsilon} = \frac{0.8}{0.550} = 1.45.$$

<

**COMMENTS:** Note that Eq. 12.42 is based on the assumption that the directional emissivity is independent of the  $\phi$  coordinate. If this is not the case, then Eq. 12.41 would need to be evaluated.



### PROBLEM 12.42

**KNOWN:** Incandescent sphere suspended in air within a darkened room exhibiting these characteristics:

*initially:* brighter around the rim

*after some time:* brighter in the center

**FIND:** Plausible explanation for these observations.

**ASSUMPTIONS:** (1) The sphere is at a uniform surface temperature,  $T_s$ .

**ANALYSIS:** Recognize that in observing the sphere by eye, emission from the central region is in a nearly normal direction. Emission from the rim region, however, has a large angle from the normal to the surface.

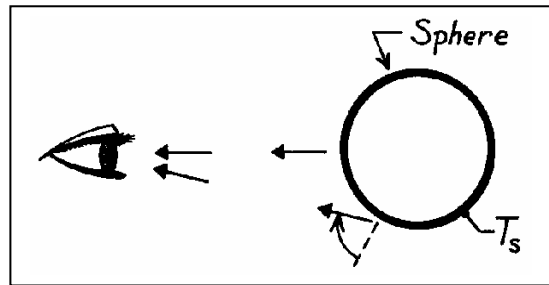

Note now the directional behavior,  $\epsilon_\theta$ , for conductors and non-conductors as represented in Fig. 12.16.

Assume that the sphere is fabricated from a *metallic* material. Then, the rim would appear brighter than the central region. This follows since  $\epsilon_\theta$  is higher at higher angles of emission.

If the metallic sphere oxidizes with time, then the  $\epsilon_\theta$  characteristics change. Then  $\epsilon_\theta$  at small angles of  $\theta$  become larger than at higher angles. This would cause the sphere to appear brighter at the center portion of the sphere.

**COMMENTS:** Since the emissivity of non-conductors is generally larger than for metallic materials, you would also expect the oxidized sphere to appear brighter for the same surface temperature.

### PROBLEM 12.43

**KNOWN:** Surface area, temperature, and emissivity of the heated surface  $A_1$ . Surface area and orientation of area  $A_2$ . Distance  $L_1$  between the two surfaces.

**FIND:** (a) Distance,  $L_2$ , between the two surfaces associated with maximum irradiation on surface 2, when surface 1 emits diffusely with  $\varepsilon = 0.85$ . (b) Distance associated with maximum irradiation, when the directional emissivity of surface 1 is  $\varepsilon_\theta = \varepsilon_n \cos\theta$ . (c) Plot irradiation on surface 2 for  $0 \leq L_2 \leq 10$  m.

**SCHEMATIC:**

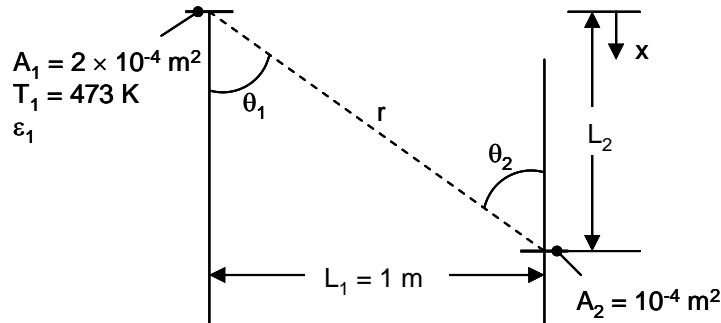

**ASSUMPTIONS:** (1) Surfaces can be treated as differential areas.

**ANALYSIS:** (a) Treating both surfaces as differential areas, from Eq. 12.7 and Example 12.1,

$$\omega_{2-1} = A_2 \cos\theta_2 / r^2$$

Then from Eq. 12.11 the total radiation from surface 1 to surface 2 is,

$$q_{1-2} = I_{e1} A_1 \cos\theta_1 \omega_{2-1} = (\varepsilon_1 E_{b1} / \pi) A_1 \cos\theta_1 (A_2 \cos\theta_2 / r^2) \quad (1)$$

Since  $\cos\theta_1 = \cos\theta_2 = L_2 / r$  and  $r^2 = L_1^2 + L_2^2$ , Eq. (1) can be written

$$q_{1-2} = (\varepsilon_1 E_{b1} / \pi) A_1 A_2 L_2^2 / (L_1^2 + L_2^2)^2 \quad (2)$$

We can find the value of  $L_2$  corresponding to the maximum value of  $q_{1-2}$  by differentiating Eq. (2) with respect to  $L_2$  and setting the derivative equal to zero,

$$\frac{dq_{1-2}}{dL_2} = \frac{\varepsilon_1 E_{b1}}{\pi} A_1 A_2 \left( \frac{2L_2(L_1^2 + L_2^2) - 4L_2^3}{(L_1^2 + L_2^2)^3} \right) = 0$$

$$L_{2,crit} = L_1$$

<

Continued...

**PROBLEM 12.43 (Cont.)**

(b) We repeat the calculation for the case in which surface 1 is no longer diffuse. The radiation heat transfer rate is still given by Eq. (2), except that the emissivity is the value for radiation in the direction corresponding to  $\theta_1$ . That is,

$$q_{1-2} = (\epsilon_{n1} \cos \theta_1 E_{b1} / \pi) A_1 A_2 L_2^2 / (L_1^2 + L_2^2)^2 = (\epsilon_{n1} E_{b1} / \pi) A_1 A_2 L_2^3 / (L_1^2 + L_2^2)^{2.5} \quad (3)$$

Differentiating Eq. (3),

$$\frac{dq_{1-2}}{dL_2} = \frac{\epsilon_{n1} E_{b1}}{\pi} A_1 A_2 \left( \frac{3L_2^2 (L_1^2 + L_2^2) - 5L_2^4}{(L_1^2 + L_2^2)^{3.5}} \right) = 0$$

$$L_2 = \sqrt{3/2} L_1 = 1.225 L_1$$

(c) Eqs. (2) and (3) were keyed into the *IHT* workspace and the following graph was generated.

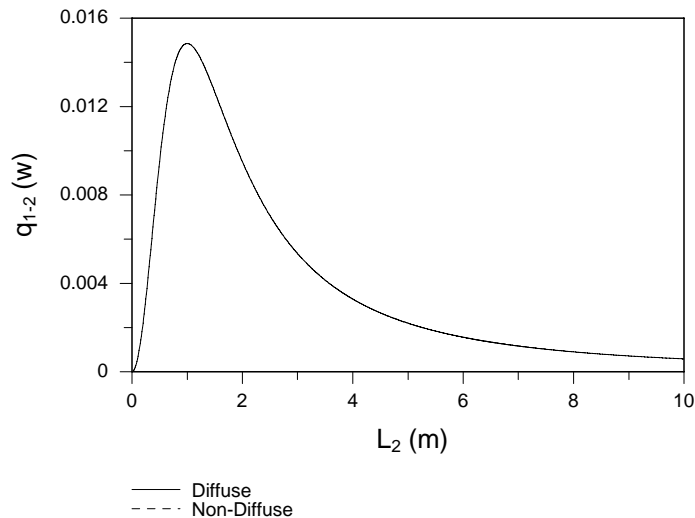

**COMMENTS:** (1) The value of  $L_{2,crit}$  is independent of the object's temperature or emissivity, but does depend on the directional nature of the emissivity. If the detector is calibrated to respond to the proximity of a diffuse object and the object emits as a typical non-metallic material, an error of  $(1.225 - 1)/1.225 = 18\%$  results. (2) The value of  $L_{2,crit}$  can be changed by changing the separation distance,  $L_1$ . (3) The temperature and emissivity of the hotter surface must be relatively high, otherwise the reflected component will dominate and the device will not work.

## PROBLEM 12.44

**KNOWN:** Temperature of polished stainless steel. Spectral emissivity distribution.

**FIND:** Total hemispherical emissivity using 5-band integration. Emissive power.

**SCHEMATIC:**

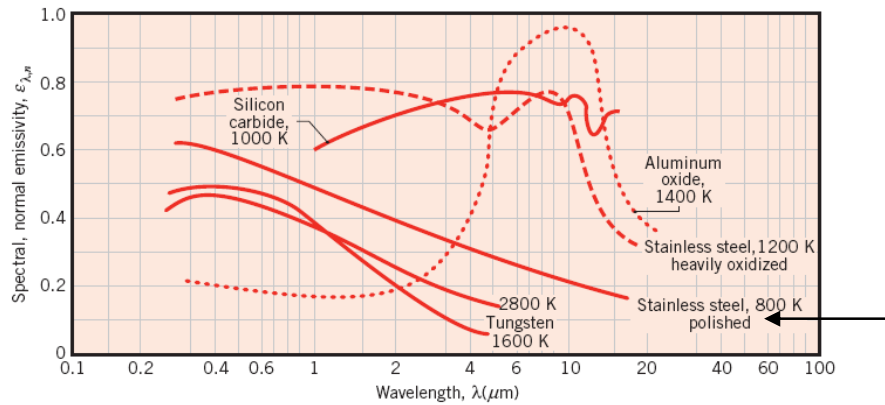

**ASSUMPTIONS:** Spectral hemispherical and normal emissivities are equal.

**ANALYSIS:** From Equation 12.43,

$$\epsilon(T) = \frac{\int_0^{\infty} \epsilon_{\lambda} E_{\lambda,b} d\lambda}{E_b} = \frac{\sum_{i=1}^5 \epsilon_i \int_{\Delta\lambda_i} E_{\lambda,b} d\lambda}{E_b} = \sum_{i=1}^5 \epsilon_i F_{(\lambda_{i-1} \rightarrow \lambda_i)} = \sum_{i=1}^5 \epsilon_i (0.2)$$

The last equality results from the choice that each band contains 20% of the blackbody emission. The median wavelength for the first band is chosen such that  $F_{(0 \rightarrow \lambda_m)} = 0.1$ . Interpolating in Table 12.1,

$F_{(0 \rightarrow \lambda_m)} = 0.1$  when  $\lambda_{m,1} T = 2195 \mu\text{m}\cdot\text{K}$ . For  $T = 800 \text{ K}$ ,  $\lambda_{m,1} = 2195 \mu\text{m}\cdot\text{K}/800 \text{ K} = 2.74 \mu\text{m}$ . From

Figure 12.17,  $\epsilon_1 = \epsilon_{n,1} \approx 0.35$ . The following table can be constructed for all the bands:

Band	$F_{(0 \rightarrow \lambda_m)}$	$\lambda_m$ ( $\mu\text{m}$ )	$\epsilon$
1	0.1	2.74	0.35
2	0.3	3.90	0.31
3	0.5	5.14	0.28
4	0.7	6.99	0.26
5	0.9	11.73	0.20

Thus,

$$\epsilon = (\epsilon_1 + \epsilon_2 + \epsilon_3 + \epsilon_4 + \epsilon_5)(0.2) = (0.35 + 0.31 + 0.28 + 0.26 + 0.20)/5 = 0.28 \quad <$$

The surface emissive power is

$$E = \epsilon \sigma T^4 = 0.28 \times 5.67 \times 10^{-8} \text{ W/m}^2 \cdot \text{K} \times (800 \text{ K})^4 = 6500 \text{ W/m}^2 \quad <$$

**COMMENTS:** Estimating the average emissivity value directly from Figure 12.17 might suggest an average value of about 0.4, leading to a 40% error in the emissive power calculation. Much of the high emissivity data plotted in Figure 12.17 are for regions for which there is negligible blackbody radiation at 800 K (see Figure 12.12).

## PROBLEM 12.45

**KNOWN:** Radiation thermometer responding to radiant power within a prescribed spectral interval and calibrated to indicate the temperature of a blackbody.

**FIND:** (a) Whether radiation thermometer will indicate temperature greater than, less than, or equal to  $T_s$  when surface has  $\varepsilon < 1$ , (b) Expression for  $T_s$  in terms of spectral radiance temperature and spectral emissivity, (c) Indicated temperature for prescribed conditions of  $T_s$  and  $\varepsilon_\lambda$ .

**SCHEMATIC:**

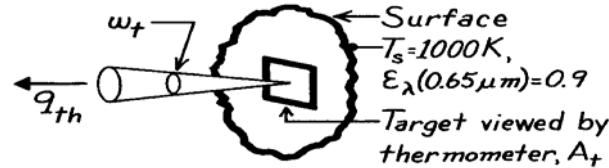

**ASSUMPTIONS:** (1) Surface is a diffuse emitter, (2) Thermometer responds to radiant flux over interval  $d\lambda$  about  $\lambda$ .

**ANALYSIS:** (a) The radiant power which reaches the radiation thermometer is

$$q_\lambda = \varepsilon_\lambda I_{\lambda,b}(\lambda, T_s) \cdot A_t \cdot \omega_t \quad (1)$$

where  $A_t$  is the area of the surface viewed by the thermometer (referred to as the target) and  $\omega_t$  the solid angle through which  $A_t$  is viewed. The thermometer responds as if it were viewing a blackbody at  $T_\lambda$ , the spectral radiance temperature,

$$q_\lambda = I_{\lambda,b}(\lambda, T_\lambda) \cdot A_t \cdot \omega_t. \quad (2)$$

By equating the two relations, Eqs. (1) and (2), find

$$I_{\lambda,b}(\lambda, T_\lambda) = \varepsilon_\lambda I_{\lambda,b}(\lambda, T_s). \quad (3)$$

Since  $\varepsilon_\lambda < 1$ , it follows that  $I_{\lambda,b}(\lambda, T_\lambda) < I_{\lambda,b}(\lambda, T_s)$  or that  $T_\lambda < T_s$ . That is, the thermometer will always indicate a temperature lower than the true or actual temperature for a surface with  $\varepsilon < 1$ .

(b) Using Wien's distribution in Eq. (3), find

$$I_\lambda(\lambda, T) = \frac{1}{\pi} C_1 \lambda^{-5} \exp(-C_2 / \lambda T)$$

$$\frac{1}{\pi} C_1 \lambda^{-5} \exp(-C_2 / \lambda T_\lambda) = \varepsilon_\lambda \cdot \frac{1}{\pi} C_1 \lambda^{-5} \exp(-C_2 / \lambda T_s).$$

Canceling terms  $(C_1 \lambda^{-5} / \pi)$ , taking natural logs of both sides of the equation and rearranging, the desired expression is

$$\frac{1}{T_s} = \frac{1}{T_\lambda} + \frac{\lambda}{C_2} \ln \varepsilon_\lambda. \quad (4) \quad <$$

(c) For  $T_s = 1000\text{K}$  and  $\varepsilon = 0.9$ , from Eq. (4), the indicated temperature is

$$\frac{1}{T_\lambda} = \frac{1}{T_s} - \frac{\lambda}{C_2} \ln \varepsilon_\lambda = \frac{1}{1000\text{K}} - \frac{0.65 \mu\text{m}}{14,388 \mu\text{m} \cdot \text{K}} \ln(0.9) \quad T_\lambda = 995.3\text{K}. \quad <$$

That is, the thermometer indicates 5K less than the true temperature. The ratio of the emissive power by Wien's distribution to that by the Planck distribution is,

$$\frac{E_{\lambda,b,\text{Wien}}}{E_{\lambda,b,\text{Planck}}} = \frac{1/\exp(C_2 / \lambda T)}{1/[\exp(C_2 / \lambda T) - 1]}.$$

Continued...

### Problem 12.45 (Cont.)

For the condition  $\lambda T = 0.65 \mu\text{m} \times 1000 \text{ K} = 650 \mu\text{m}\cdot\text{K}$ ,  $C_2/\lambda T = 14388 \mu\text{m}\cdot\text{K}/650 \mu\text{m}\cdot\text{K} = 22.14$  and

$$\frac{E_{\lambda,b}|_{\text{Wien}}}{E_{\lambda,b}|_{\text{Planck}}} = \frac{1/\exp(22.14)}{1/[\exp(22.14)-1]} = 0.995. \quad <$$

Thus, Wien's spectral distribution is an excellent approximation to Planck's distribution for this situation.

### PROBLEM 12.46

**KNOWN:** Spectral distribution of emission from a blackbody. Uncertainty in measurement of intensity.

**FIND:** Corresponding uncertainties in using the intensity measurement to determine (a) the surface temperature or (b) the emissivity.

**ASSUMPTIONS:** Diffuse surface behavior.

**ANALYSIS:** From Eq. 12.29, the spectral intensity associated with emission may be expressed as

$$I_{\lambda,e} = \varepsilon_{\lambda} I_{\lambda,b} = \frac{\varepsilon_{\lambda} C_1 / \pi}{\lambda^5 [\exp(C_2 / \lambda T) - 1]}$$

(a) To determine the effect of temperature on intensity, we evaluate the derivative,

$$\frac{\partial I_{\lambda,e}}{\partial T} = - \frac{(\varepsilon_{\lambda} C_1 / \pi) \lambda^5 \exp(C_2 / \lambda T) (-C_2 / \lambda T^2)}{\left\{ \lambda^5 [\exp(C_2 / \lambda T) - 1] \right\}^2}$$

$$\frac{\partial I_{\lambda,e}}{\partial T} = \frac{(C_2 / \lambda T^2) \exp(C_2 / \lambda T)}{\exp(C_2 / \lambda T) - 1} I_{\lambda,e}$$

Hence,

$$\frac{dT}{T} = \frac{1 - \exp(-C_2 / \lambda T)}{(C_2 / \lambda T)} \frac{dI_{\lambda,e}}{I_{\lambda,e}}$$

With  $(dI_{\lambda,e} / I_{\lambda,e}) = 0.1$ ,  $C_2 = 1.439 \times 10^4 \mu\text{m} \cdot \text{K}$  and  $\lambda = 10 \mu\text{m}$ ,

$$\frac{dT}{T} = \left[ \frac{1 - \exp(-1439 \text{ K} / T)}{1439 \text{ K} / T} \right] \times 0.1$$

$$T = 500 \text{ K}: \quad dT/T = 0.033 \rightarrow 3.3\% \text{ uncertainty} \quad <$$

$$T = 1000 \text{ K}: \quad dT/T = 0.053 \rightarrow 5.3\% \text{ uncertainty} \quad <$$

(b) To determine the effect of the emissivity on intensity, we evaluate

$$\frac{\partial I_{\lambda,e}}{\partial \varepsilon_{\lambda}} = I_{\lambda,b} = \frac{I_{\lambda,e}}{\varepsilon_{\lambda}}$$

$$\text{Hence, } \frac{d\varepsilon_{\lambda}}{\varepsilon_{\lambda}} = \frac{dI_{\lambda,e}}{I_{\lambda,e}} = 0.10 \rightarrow 10\% \text{ uncertainty} \quad <$$

**COMMENTS:** The uncertainty in the temperature is less than that of the intensity, but increases with increasing temperature (and wavelength). In the limit as  $C_2 / \lambda T \rightarrow 0$ ,  $\exp(-C_2 / \lambda T) \rightarrow 1 - C_2 / \lambda T$  and  $dT/T \rightarrow dI_{\lambda,e} / I_{\lambda,e}$ . The uncertainty in temperature then corresponds to that of the intensity measurement. The same is true for the uncertainty in the emissivity, irrespective of the value of  $T$  or  $\lambda$ .

### PROBLEM 12.47

**KNOWN:** Temperature, thickness and spectral emissivity of steel strip emerging from a hot roller. Temperature dependence of total, hemispherical emissivity.

**FIND:** (a) Initial total, hemispherical emissivity, (b) Initial cooling rate, (c) Time to cool to prescribed final temperature.

**SCHEMATIC:**

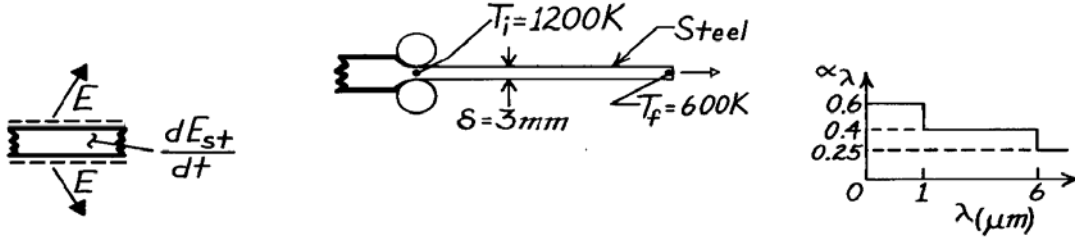

**ASSUMPTIONS:** (1) Negligible conduction (in longitudinal direction), convection and radiation from surroundings, (2) Negligible transverse temperature gradients.

**PROPERTIES:** Steel (given):  $\rho = 7900 \text{ kg/m}^3$ ,  $c = 640 \text{ J/kg}\cdot\text{K}$ ,  $\varepsilon = 1200\varepsilon_i/T \text{ (K)}$ .

**ANALYSIS:** (a) The initial total hemispherical emissivity is

$$\varepsilon_i = \int_0^{\infty} \varepsilon_{\lambda} [E_{\lambda b}(1200)/E_b(1200)] d\lambda$$

and integrating by parts using values from Table 12.1, find

$$\lambda T = 1200 \mu\text{m}\cdot\text{K} \rightarrow F_{(0-1\mu\text{m})} = 0.002; \lambda T = 7200 \mu\text{m}\cdot\text{K} \rightarrow F_{(0-6\mu\text{m})} = 0.819$$

$$\varepsilon_i = 0.6 \times 0.002 + 0.4(0.819 - 0.002) + 0.25(1 - 0.819) = 0.373. \quad <$$

(b) From an energy balance on a unit surface area of strip (top and bottom),

$$-\dot{E}_{\text{out}} = dE_{\text{st}}/dt \quad -2\varepsilon\sigma T^4 = d(\rho\delta cT)/dt$$

$$\left. \frac{dT}{dt} \right|_i = -\frac{2\varepsilon_i\sigma T_i^4}{\rho\delta c} = \frac{-2(0.373)5.67 \times 10^{-8} \text{ W/m}^2 \cdot \text{K}^4 (1200 \text{ K})^4}{7900 \text{ kg/m}^3 (0.003 \text{ m})(640 \text{ J/kg}\cdot\text{K})} = -5.78 \text{ K/s}. \quad <$$

(c) From the energy balance,

$$\frac{dT}{dt} = -\frac{2\varepsilon_i(1200/T)\sigma T^4}{\rho\delta c}, \int_{T_i}^{T_f} \frac{dT}{T^3} = -\frac{2400\varepsilon_i\sigma}{\rho\delta c} \int_0^t dt, \quad t = \frac{\rho\delta c}{4800\varepsilon_i\sigma} \left( \frac{1}{T_f^2} - \frac{1}{T_i^2} \right)$$

$$t = \frac{7900 \text{ kg/m}^3 (0.003 \text{ m}) 640 \text{ J/kg}\cdot\text{K}}{4800 \text{ K} \times 0.373 \times 5.67 \times 10^{-8} \text{ W/m}^2 \cdot \text{K}^4} \left( \frac{1}{600^2} - \frac{1}{1200^2} \right) \text{K}^{-2} = 311 \text{ s}. \quad <$$

**COMMENTS:** Initially, from Eq. 1.9,  $h_r \approx \varepsilon_i\sigma T_i^3 = 36.6 \text{ W/m}^2 \cdot \text{K}$ . Assuming a plate width of  $W = 1 \text{ m}$ , the Rayleigh number may be evaluated from  $Ra_L = g\beta(T_i - T_{\infty})(W/2)^3/\nu\alpha$ . Assuming  $T_{\infty} = 300 \text{ K}$  and evaluating properties at  $T_f = 750 \text{ K}$ ,  $Ra_L = 1.8 \times 10^8$ . From Eq. 9.31,  $Nu_L = 84$ , giving  $\bar{h} = 9.2 \text{ W/m}^2 \cdot \text{K}$ . Hence heat loss by radiation exceeds that associated with free convection. To check the validity of neglecting transverse temperature gradients, compute  $Bi = h(\delta/2)/k$ . With  $h = 36.6 \text{ W/m}^2 \cdot \text{K}$  and  $k = 28 \text{ W/m}\cdot\text{K}$ ,  $Bi = 0.002 \ll 1$ . Hence the assumption is valid.



### PROBLEM 12.48

**KNOWN:** Large body of nonluminous gas at 1200 K has emission bands between 2.5 – 3.5  $\mu\text{m}$  and between 5 – 8  $\mu\text{m}$  with effective emissivities of 0.8 and 0.6, respectively.

**FIND:** Emissive power of the gas.

**SCHEMATIC:** —

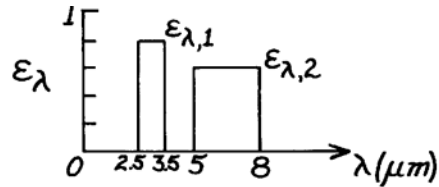
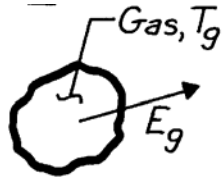

**ASSUMPTIONS:** (1) Gas radiates only in specified bands, (2) Emitted radiation is diffuse.

**ANALYSIS:** The emissive power of the gas is

$$E_g = \varepsilon E_b(T_g) = \int_0^{\infty} \varepsilon_{\lambda} E_{\lambda,b}(T_g) d\lambda$$

$$E_g = \int_{2.5}^{3.5} \varepsilon_{\lambda,1} E_{\lambda,b}(T_g) d\lambda + \int_5^8 \varepsilon_{\lambda,2} E_{\lambda,b}(T_g) d\lambda$$

$$E_g = \left[ \varepsilon_1 F(2.5-3.5 \mu\text{m}) + \varepsilon_2 F(5-8 \mu\text{m}) \right] \sigma T_g^4.$$

Using the blackbody function  $F_{(0-\lambda T)}$  from Table 12.1 with  $T_g = 1200$  K,

$\lambda T(\mu\text{m}\cdot\text{K})$	$2.5 \times 1200$	$3.5 \times 1200$	$5 \times 1200$	$8 \times 1200$
	3000	4200	6000	9600
$F_{(0-\lambda T)}$	0.273	0.516	0.738	0.905

so that

$$F(2.5-3.5 \mu\text{m}) = F(0-3.5 \mu\text{m}) - F(0-2.5 \mu\text{m}) = 0.516 - 0.273 = 0.243$$

$$F(5-8 \mu\text{m}) = F(0-8 \mu\text{m}) - F(0-5 \mu\text{m}) = 0.905 - 0.738 = 0.167.$$

Hence the emissive power is

$$E_g = [0.8 \times 0.243 + 0.6 \times 0.167] 5.67 \times 10^{-8} \text{ W/m}^2 \cdot \text{K}^4 (1200 \text{ K})^4$$

$$E_g = 0.295 \times 117,573 \text{ W/m}^2 = 34,684 \text{ W/m}^2. \quad <$$

**COMMENTS:** Note that the effective emissivity for the gas is 0.295. This seems surprising since emission occurs only at the discrete bands. Since  $\lambda_{\text{max}} = 2.4 \mu\text{m}$ , all of the spectral emissive power is at wavelengths beyond the peak of blackbody radiation at 1200 K.

## PROBLEM 12.49

**KNOWN:** An opaque surface with prescribed spectral, hemispherical reflectivity distribution is subjected to a prescribed spectral irradiation.

**FIND:** (a) The spectral, hemispherical absorptivity, (b) Total irradiation, (c) The absorbed radiant flux, and (d) Total, hemispherical absorptivity.

**SCHEMATIC:**

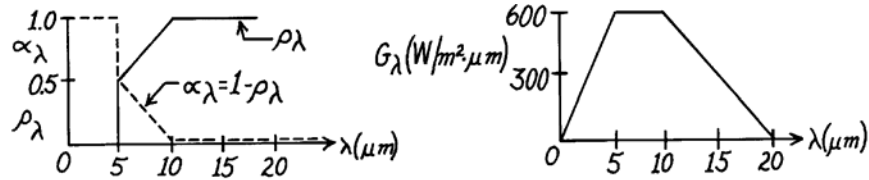

**ASSUMPTIONS:** (1) Surface is opaque.

**ANALYSIS:** (a) The spectral, hemispherical absorptivity,  $\alpha_\lambda$ , for an opaque surface is given by Eq. 12.62,

$$\alpha_\lambda = 1 - \rho_\lambda \quad <$$

which is shown as a dashed line on the  $\rho_\lambda$  distribution axes.

(b) The total irradiation,  $G$ , follows from Eq. 12.19 which can be integrated by parts,

$$G = \int_0^\infty G_\lambda d\lambda = \int_0^{5\mu\text{m}} G_\lambda d\lambda + \int_{5\mu\text{m}}^{10\mu\text{m}} G_\lambda d\lambda + \int_{10\mu\text{m}}^{20\mu\text{m}} G_\lambda d\lambda$$

$$G = \frac{1}{2} \times 600 \frac{\text{W}}{\text{m}^2 \cdot \mu\text{m}} (5 - 0) \mu\text{m} + 600 \frac{\text{W}}{\text{m}^2 \cdot \mu\text{m}} (10 - 5) \mu\text{m} + \frac{1}{2} \times 600 \frac{\text{W}}{\text{m}^2 \cdot \mu\text{m}} \times (20 - 10) \mu\text{m}$$

$$G = 7500 \text{ W/m}^2. \quad <$$

(c) The absorbed irradiation follows from Eqs. 12.51 and 12.52 with the form

$$G_{\text{abs}} = \int_0^\infty \alpha_\lambda G_\lambda d\lambda = \alpha_1 \int_0^{5\mu\text{m}} G_\lambda d\lambda + G_{\lambda,2} \int_{5\mu\text{m}}^{10\mu\text{m}} \alpha_\lambda d\lambda + \alpha_3 \int_{10\mu\text{m}}^{20\mu\text{m}} G_\lambda d\lambda.$$

Noting that  $\alpha_1 = 1.0$  for  $\lambda = 0 \rightarrow 5 \mu\text{m}$ ,  $G_{\lambda,2} = 600 \text{ W/m}^2 \cdot \mu\text{m}$  for  $\lambda = 5 \rightarrow 10 \mu\text{m}$  and  $\alpha_3 = 0$  for  $\lambda > 10 \mu\text{m}$ , find that

$$G_{\text{abs}} = 1.0 \left( 0.5 \times 600 \text{ W/m}^2 \cdot \mu\text{m} \right) (5 - 0) \mu\text{m} + 600 \text{ W/m}^2 \cdot \mu\text{m} (0.5 \times 0.5) (10 - 5) \mu\text{m} + 0$$

$$G_{\text{abs}} = 2250 \text{ W/m}^2. \quad <$$

(d) The total, hemispherical absorptivity is defined as the fraction of the total irradiation that is absorbed. From Eq. 12.51,

$$\alpha = \frac{G_{\text{abs}}}{G} = \frac{2250 \text{ W/m}^2}{7500 \text{ W/m}^2} = 0.30. \quad <$$

**COMMENTS:** Recognize that the total, hemispherical absorptivity,  $\alpha = 0.3$ , is for the given spectral irradiation. For a different  $G_\lambda$ , one would then expect a different value for  $\alpha$ .

## PROBLEM 12.50

**KNOWN:** Temperature and spectral emissivity of small object suspended in large furnace of prescribed temperature and total emissivity.

**FIND:** (a) Total surface emissivity and absorptivity, (b) Reflected radiative flux and net radiative flux to surface, (c) Spectral emissive power at  $\lambda = 2 \mu\text{m}$ , (d) Wavelength  $\lambda_{1/2}$  for which one-half of total emissive power is in spectral region  $\lambda \geq \lambda_{1/2}$ .

**SCHEMATIC:**

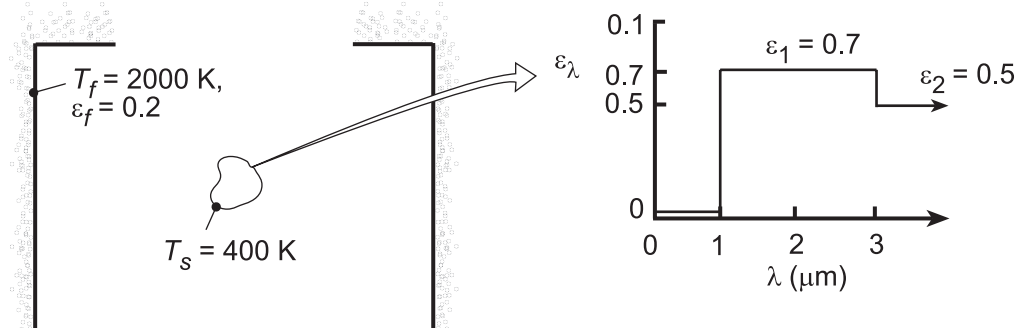

**ASSUMPTIONS:** (1) Surface is opaque and diffuse, (2) Walls of furnace are much larger than object.

**ANALYSIS:** (a) The emissivity of the object may be obtained from Eq. 12.43, which is expressed as

$$\varepsilon(T_s) = \frac{\int_0^{\infty} \varepsilon_{\lambda}(\lambda) E_{\lambda,b}(\lambda, T_s) d\lambda}{E_b(T)} = \varepsilon_1 \left[ F_{(0 \rightarrow 3\mu\text{m})} - F_{(0 \rightarrow 1\mu\text{m})} \right] + \varepsilon_2 \left[ 1 - F_{(0 \rightarrow 3\mu\text{m})} \right]$$

where, with  $\lambda_1 T_s = 400 \mu\text{m}\cdot\text{K}$  and  $\lambda_2 T_s = 1200 \mu\text{m}\cdot\text{K}$ ,  $F_{(0 \rightarrow 1\mu\text{m})} = 0$  and  $F_{(0 \rightarrow 3\mu\text{m})} = 0.002$ . Hence,

$$\varepsilon(T_s) = 0.7(0.002) + 0.5(0.998) = 0.500 \quad <$$

The absorptivity of the surface is determined by Eq. 12.52,

$$\alpha = \frac{\int_0^{\infty} \alpha_{\lambda}(\lambda) G_{\lambda}(\lambda) d\lambda}{\int_0^{\infty} G_{\lambda}(\lambda) d\lambda} = \frac{\int_0^{\infty} \alpha_{\lambda}(\lambda) E_{\lambda,b}(\lambda, T_f) d\lambda}{E_b(T_f)}$$

Hence, with  $\lambda_1 T_f = 2000 \mu\text{m}\cdot\text{K}$  and  $\lambda_2 T_f = 6000 \mu\text{m}\cdot\text{K}$ ,  $F_{(0 \rightarrow 1\mu\text{m})} = 0.067$  and  $F_{(0 \rightarrow 3\mu\text{m})} = 0.738$ . It follows that

$$\alpha = \alpha_1 \left[ F_{(0 \rightarrow 3\mu\text{m})} - F_{(0 \rightarrow 1\mu\text{m})} \right] + \alpha_2 \left[ 1 - F_{(0 \rightarrow 3\mu\text{m})} \right] = 0.7 \times 0.671 + 0.5 \times 0.262 = 0.601 \quad <$$

(b) The reflected radiative flux is

$$G_{\text{ref}} = \rho G = (1 - \alpha) E_b(T_f) = 0.399 \times 5.67 \times 10^{-8} \text{ W/m}^2 \cdot \text{K}^4 (2000 \text{ K})^4 = 3.620 \times 10^5 \text{ W/m}^2 \quad <$$

The net radiative flux to the surface is

$$q_{\text{rad}}'' = G - \rho G - \varepsilon E_b(T_s) = \alpha E_b(T_f) - \varepsilon E_b(T_s)$$

$$q_{\text{rad}}'' = 5.67 \times 10^{-8} \text{ W/m}^2 \cdot \text{K}^4 \left[ 0.601 (2000 \text{ K})^4 - 0.500 (400 \text{ K})^4 \right] = 5.438 \times 10^5 \text{ W/m}^2 \quad <$$

(c) At  $\lambda = 2 \mu\text{m}$ ,  $\lambda T_s = 800 \text{ K}$  and, from Table 12.1,  $I_{\lambda,b}(\lambda, T) / \sigma T^5 = 0.991 \times 10^{-7} (\mu\text{m}\cdot\text{K}\cdot\text{sr})^{-1}$ . Hence,

Continued...

**PROBLEM 12.50 (Cont.)**

$$I_{\lambda,b} = 0.991 \times 10^{-7} \times 5.67 \times 10^{-8} \frac{\text{W}/\text{m}^2 \cdot \text{K}^4}{\mu\text{m} \cdot \text{K} \cdot \text{sr}} \times (400 \text{ K})^5 = 0.0575 \frac{\text{W}}{\text{m}^2 \cdot \mu\text{m} \cdot \text{sr}}$$

Hence, with  $E_{\lambda} = \varepsilon_{\lambda} E_{\lambda,b} = \varepsilon_{\lambda} \pi I_{\lambda,b}$ ,

$$E_{\lambda} = 0.7 (\pi \text{sr}) 0.0575 \text{ W}/\text{m}^2 \cdot \mu\text{m} \cdot \text{sr} = 0.126 \text{ W}/\text{m}^2 \cdot \mu\text{m} \quad <$$

(d) From Table 12.1,  $F_{(0 \rightarrow \lambda)} = 0.5$  corresponds to  $\lambda T_s \approx 4100 \mu\text{m} \cdot \text{K}$ , in which case,

$$\lambda_{1/2} \approx 4100 \mu\text{m} \cdot \text{K} / 400 \text{ K} \approx 10.3 \mu\text{m} \quad <$$

**COMMENTS:** Because of the significant difference between  $T_f$  and  $T_s$ ,  $\alpha \neq \varepsilon$ . With increasing  $T_s \rightarrow T_f$ ,  $\varepsilon$  would increase and approach a value of 0.601.

## PROBLEM 12.51

**KNOWN:** Small flat plate maintained at 400 K coated with white paint having spectral absorptivity distribution (Figure 12.22) approximated as a staircase function. Enclosure surface maintained at 3000 K with prescribed spectral emissivity distribution.

**FIND:** (a) Total emissivity of the enclosure surface,  $\epsilon_{es}$ , and (b) Total emissivity,  $\epsilon$ , and absorptivity,  $\alpha$ , of the surface.

**SCHEMATIC:**

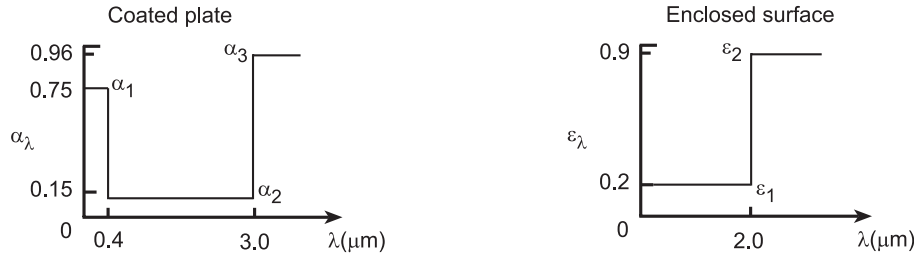

**ASSUMPTIONS:** (1) Coated plate with white paint is diffuse and opaque, so that  $\alpha_\lambda = \epsilon_\lambda$ , (2) Plate is small compared to the enclosure surface, and (3) Enclosure surface is isothermal, diffuse and opaque.

**ANALYSIS:** (a) The total emissivity of the enclosure surface at  $T_{es} = 3000$  K follows from Eq. 12.43 which can be expressed in terms of the band emission factor,  $F_{(0-\lambda T)}$ , Eq. 12.35,

$$\epsilon_{e,s} = \epsilon_1 F_{(0-\lambda_1 T_{es})} + \epsilon_2 [1 - F_{(0-\lambda_1 T_{es})}] = 0.2 \times 0.738 + 0.9 [1 - 0.738] = 0.383 \quad <$$

where, from Table 12.1, with  $\lambda_1 T_{es} = 2 \mu\text{m} \times 3000 \text{ K} = 6000 \mu\text{m}\cdot\text{K}$ ,  $F_{(0-\lambda T)} = 0.738$ .

(b) The total emissivity of the coated plate at  $T = 400$  K can be expressed as

$$\epsilon = \alpha_1 F_{(0-\lambda_1 T_s)} + \alpha_2 [F_{(0-\lambda_2 T_s)} - F_{(0-\lambda_1 T_s)}] + \alpha_3 [1 - F_{(0-\lambda_2 T_s)}]$$

$$\epsilon = 0.75 \times 0 + 0.15 [0.002134 - 0.000] + 0.96 [1 - 0.002134] = 0.958 \quad <$$

where, from Table 12.1, the band emission factors are: for  $\lambda_1 T_s = 0.4 \times 400 = 160 \mu\text{m}\cdot\text{K}$ , find  $F_{(0-\lambda_1 T_s)} = 0.000$ ; for  $\lambda_2 T_s = 3.0 \times 400 = 1200 \mu\text{m}\cdot\text{K}$ , find  $F_{(0-\lambda_2 T_s)} = 0.002134$ . The total absorptivity for the irradiation due to the enclosure surface at  $T_{es} = 3000$  K is

$$\alpha = \alpha_1 F_{(0-\lambda_1 T_{es})} + \alpha_2 [F_{(0-\lambda_2 T_{es})} - F_{(0-\lambda_1 T_{es})}] + \alpha_3 [1 - F_{(0-\lambda_2 T_{es})}]$$

$$\alpha = 0.75 \times 0.002134 + 0.15 [0.8900 - 0.002134] + 0.96 [1 - 0.8900] = 0.240 \quad <$$

where, from Table 12.1, the band emission factors are: for  $\lambda_1 T_{es} = 0.4 \times 3000 = 1200 \mu\text{m}\cdot\text{K}$ , find  $F_{(0-\lambda_1 T_{es})} = 0.002134$ ; for  $\lambda_2 T_{es} = 3.0 \times 3000 = 9000 \mu\text{m}\cdot\text{K}$ , find  $F_{(0-\lambda_2 T_{es})} = 0.8900$ .

**COMMENTS:** (1) In evaluating the total emissivity and absorptivity, remember that  $\epsilon = \epsilon(\epsilon_\lambda, T_s)$  and  $\alpha = \alpha(\alpha_\lambda, G_\lambda)$  where  $T_s$  is the temperature of the surface and  $G_\lambda$  is the spectral irradiation, which if the surroundings are large and isothermal,  $G_\lambda = E_{b,\lambda}(T_{sur})$ . Hence,  $\alpha = \alpha(\alpha_\lambda, T_{sur})$ . For the opaque, diffuse surface,  $\alpha_\lambda = \epsilon_\lambda$ . (2) Note that the coated plate (white paint) has an absorptivity for the 3000 K-enclosure surface irradiation of  $\alpha = 0.240$ . You would expect it to be a low value since the coating appears visually “white”. (3) The emissivity of the coated plate is quite high,  $\epsilon = 0.958$ . Would you have expected this of a “white paint”? Most paints are oxide systems (high absorptivity at long wavelengths) with pigmentation (controls the “color” and hence absorptivity in the visible and near infrared regions).

## PROBLEM 12.52

**KNOWN:** Area, temperature, irradiation and spectral absorptivity of a surface.

**FIND:** Absorbed irradiation, emissive power, radiosity and net radiation transfer from the surface.

**SCHEMATIC:**

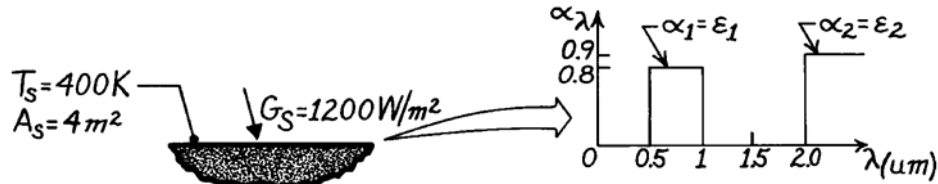

**ASSUMPTIONS:** (1) Opaque, diffuse surface behavior, (2) Spectral distribution of solar radiation corresponds to emission from a blackbody at 5800 K.

**ANALYSIS:** The absorptivity to solar irradiation is

$$\alpha_s = \frac{\int_0^\infty \alpha_\lambda G_\lambda d\lambda}{G} = \frac{\int_0^\infty \alpha_\lambda E_{\lambda b}(5800 \text{ K}) d\lambda}{E_b} = \alpha_1 F_{(0.5 \rightarrow 1 \mu\text{m})} + \alpha_2 F_{(2 \rightarrow \infty)}$$

From Table 12.1,

$$\lambda T = 2900 \mu\text{m}\cdot\text{K}:$$

$$F_{(0 \rightarrow 0.5 \mu\text{m})} = 0.250$$

$$\lambda T = 5800 \mu\text{m}\cdot\text{K}:$$

$$F_{(0 \rightarrow 1 \mu\text{m})} = 0.720$$

$$\lambda T = 11,600 \mu\text{m}\cdot\text{K}:$$

$$F_{(0 \rightarrow 2 \mu\text{m})} = 0.941$$

$$\alpha_s = 0.8(0.720 - 0.250) + 0.9(1 - 0.941) = 0.429.$$

Hence,  $G_{\text{abs}} = \alpha_s G_S = 0.429(1200 \text{ W/m}^2) = 515 \text{ W/m}^2.$  <

The emissivity is

$$\varepsilon = \frac{\int_0^\infty \varepsilon_\lambda E_{\lambda b}(400 \text{ K}) d\lambda}{E_b} = \varepsilon_1 F_{(0.5 \rightarrow 1 \mu\text{m})} + \varepsilon_2 F_{(2 \rightarrow \infty)}$$

From Table 12.1,

$$\lambda T = 200 \mu\text{m}\cdot\text{K}:$$

$$F_{(0 \rightarrow 0.5 \mu\text{m})} = 0$$

$$\lambda T = 400 \mu\text{m}\cdot\text{K}:$$

$$F_{(0 \rightarrow 1 \mu\text{m})} = 0$$

$$\lambda T = 800 \mu\text{m}\cdot\text{K}:$$

$$F_{(0 \rightarrow 2 \mu\text{m})} = 0.$$

Hence,  $\varepsilon = \varepsilon_2 = 0.9,$

$$E = \varepsilon \sigma T_s^4 = 0.9 \times 5.67 \times 10^{-8} \text{ W/m}^2 \cdot \text{K}^4 (400 \text{ K})^4 = 1306 \text{ W/m}^2. <$$

The radiosity is

$$J = E + \rho_S G_S = E + (1 - \alpha_s) G_S = [1306 + 0.571 \times 1200] \text{ W/m}^2 = 1991 \text{ W/m}^2. <$$

The net radiation transfer from the surface is

$$q_{\text{net}} = (E - \alpha_s G_S) A_s = (1306 - 515) \text{ W/m}^2 \times 4 \text{ m}^2 = 3164 \text{ W}. <$$

**COMMENTS:** Unless 3164 W are supplied to the surface by other means (for example, by convection), the surface temperature will decrease with time.

### PROBLEM 12.53

**KNOWN:** Solar irradiation, specular reflectivity of polished silver, absorptivity of wood, cumulative irradiation of  $N$  mirrors from  $N$  students,  $G_{s,N} = 70,000 \text{ W/m}^2$  as in Problem 4.51.

**FIND:** (a) Number of students,  $N$ , for first-surface mirrors, (b) Number of students,  $N$ , for second-surface mirrors.

**SCHEMATIC:**

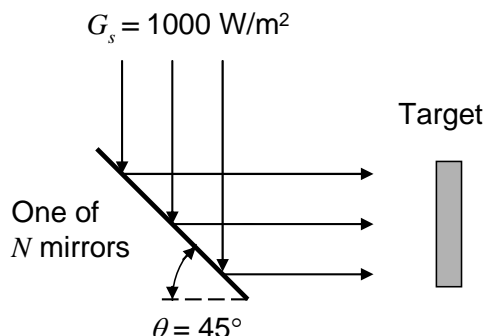

**ASSUMPTIONS:** (1) Spectral transmissivity of plain glass as in Problem 12.62, (2) Solar irradiation is that of a blackbody at  $T_s = 5800 \text{ K}$ .

**ANALYSIS:** (a) From the schematic for the first-surface mirror,

$$G_{s,N} = NG_s \rho_m \alpha_w \quad \text{or} \quad N = \frac{G_{s,N}}{G_s \rho_m \alpha_w} = \frac{70,000 \text{ W/m}^2}{1000 \text{ W/m}^2 \times 0.98 \times 0.80} = 90 \quad <$$

where  $\rho_m$  is the reflectivity of the silver surface and  $\alpha_w$  is the absorptivity of the wood.

(b) From the schematic for a second-surface mirror,  $G_{s,N} = NG_s \tau_g \rho_m \alpha_w$  where  $\tau_g$  is the transmissivity of the plain glass. Using Table 12.1,

$$\begin{array}{lll} \lambda_2 = 2.5 \mu\text{m} & \lambda_{2T} = 2.5 \mu\text{m} \times 5800 \text{ K} = 14,500 \mu\text{m}\cdot\text{K} & F(0 \rightarrow \lambda_2) = 0.966 \\ \lambda_1 = 0.3 \mu\text{m} & \lambda_{1T} = 0.3 \mu\text{m} \times 5800 \text{ K} = 1740 \mu\text{m}\cdot\text{K} & F(0 \rightarrow \lambda_1) = 0.033 \end{array}$$

$$\tau_g = 0.9(0.966 - 0.033) = 0.839 \quad \text{and}$$

$$N = \frac{G_{s,N}}{G_s \tau_g \rho_m \alpha_w} = \frac{70,000 \text{ W/m}^2}{1000 \text{ W/m}^2 \times 0.839 \times 0.98 \times 0.80} = 106 \quad <$$

**COMMENTS:** (1) The first-surface mirror is preferred in order to maximize the irradiation of the target. (2) First-surface mirrors are used in applications involving large radiation heat fluxes, such as in laser processing. Use of a second-surface mirrors might lead to excessive heating of the mirror material (glass) and failure of the mirrors.

### PROBLEM 12.54

**KNOWN:** Temperature and spectral emissivity of a receiving surface. Direction and spectral distribution of incident flux. Distance and aperture of surface radiation detector.

**FIND:** Radiant power received by the detector.

**SCHEMATIC:**

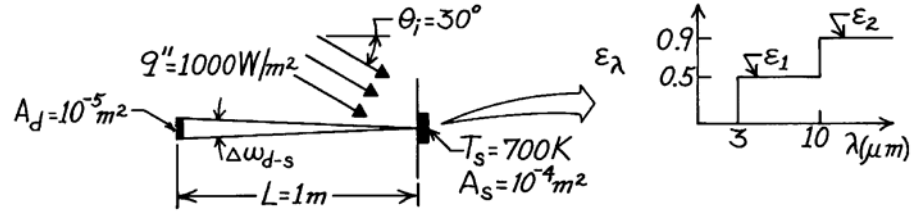

**ASSUMPTIONS:** (1) Target surface is diffuse, (2)  $A_d/L^2 \ll 1$ .

**ANALYSIS:** The radiant power received by the detector depends on emission and reflection from the target.

$$q_d = I_{e+r} A_s \cos \theta_{d-s} \Delta \omega_{d-s}$$

$$q_d = \frac{\varepsilon \sigma T_s^4 + \rho G}{\pi} A_s \frac{A_d}{L^2}$$

$$\varepsilon = \frac{\int_0^{\infty} \varepsilon_{\lambda} E_{\lambda b}(700 \text{ K}) d\lambda}{E_b(700 \text{ K})} = \varepsilon_1 F_{(3 \rightarrow 10 \mu\text{m})} + \varepsilon_2 F_{(10 \rightarrow \infty)}$$

From Table 12.1,

$$\lambda T = 2100 \mu\text{m}\cdot\text{K}:$$

$$F_{(0 \rightarrow 3 \mu\text{m})} = 0.0838$$

$$\lambda T = 7000 \mu\text{m}\cdot\text{K}:$$

$$F_{(0 \rightarrow 10 \mu\text{m})} = 0.8081.$$

The emissivity can be expected as

$$\varepsilon = 0.5(0.8081 - 0.0838) + 0.9(1 - 0.8081) = 0.535.$$

Also,

$$\rho = \frac{\int_0^{\infty} \rho_{\lambda} G_{\lambda} d\lambda}{G} = \frac{\int_0^{\infty} (1 - \varepsilon_{\lambda}) q''_{\lambda} d\lambda}{q''} = 1 \times F_{(1 \rightarrow 3 \mu\text{m})} + 0.5 \times F_{(3 \rightarrow 6 \mu\text{m})}$$

$$\rho = 1 \times 0.4 + 0.5 \times 0.6 = 0.70.$$

Hence, with  $G = q'' \cos \theta_i = 866 \text{ W/m}^2$ ,

$$q_d = \frac{0.535 \times 5.67 \times 10^{-8} \text{ W/m}^2 \cdot \text{K}^4 (700 \text{ K})^4 + 0.7 \times 866 \text{ W/m}^2}{\pi} 10^{-4} \text{ m}^2 \frac{10^{-5} \text{ m}^2}{(1 \text{ m})^2}$$

$$q_d = 2.51 \times 10^{-6} \text{ W.} \quad <$$

**COMMENTS:** A total radiation detector cannot discriminate between emitted and reflected radiation from a surface.



## PROBLEM 12.55

**KNOWN:** Small disk positioned at center of an isothermal, hemispherical enclosure with a small aperture.

**FIND:** Radiant power [ $\mu\text{W}$ ] leaving the aperture.

**SCHEMATIC:**

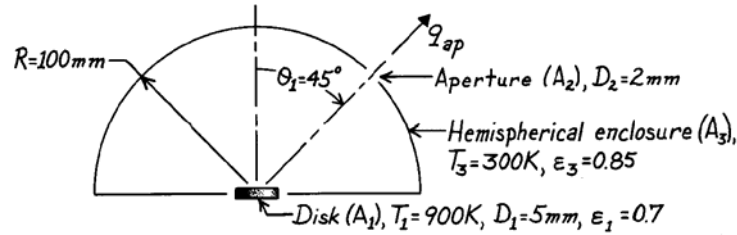

**ASSUMPTIONS:** (1) Disk is diffuse-gray, (2) Enclosure is isothermal and has area much larger than disk, (3) Aperture area is very small compared to enclosure area, (4) Areas of disk and aperture are small compared to radius squared of the enclosure.

**ANALYSIS:** The radiant power leaving the aperture is due to radiation leaving the disk and to irradiation on the aperture from the enclosure. That is,

$$q_{ap} = q_{1 \rightarrow 2} + G_2 \cdot A_2. \quad (1)$$

The radiation leaving the disk can be written in terms of the radiosity of the disk. For the diffuse disk,

$$q_{1 \rightarrow 2} = \frac{1}{\pi} J_1 \cdot A_1 \cos \theta_1 \cdot \omega_{2-1} \quad (2)$$

and with  $\varepsilon = \alpha$  for the gray behavior, the radiosity is

$$J_1 = \varepsilon_1 E_b(T_1) + \rho G_1 = \varepsilon_1 \sigma T_1^4 + (1 - \varepsilon_1) \sigma T_3^4 \quad (3)$$

where the irradiation  $G_1$  is the emissive power of the black enclosure,  $E_b(T_3)$ ;  $G_1 = G_2 = E_b(T_3)$ .

The solid angle  $\omega_{2-1}$  follows from Eq. 12.7,

$$\omega_{2-1} = A_2 / R^2. \quad (4)$$

Combining Eqs. (2), (3) and (4) into Eq. (1) with  $G_2 = \sigma T_3^4$ , the radiant power is

$$\begin{aligned} q_{ap} &= \frac{1}{\pi} \sigma \left[ \varepsilon_1 T_1^4 + (1 - \varepsilon_1) T_3^4 \right] A_1 \cos \theta_1 \cdot \frac{A_2}{R^2} + A_2 \sigma T_3^4 \\ q_{ap} &= \frac{1}{\pi} 5.67 \times 10^{-8} \frac{\text{W}}{\text{m}^2 \cdot \text{K}^4} \left[ 0.7(900\text{K})^4 + (1 - 0.7)(300\text{K})^4 \right] \frac{\pi}{4} (0.005\text{m})^2 \cos 45^\circ \times \\ &\quad \frac{\pi/4 (0.002\text{m})^2}{(0.100\text{m})^2} + \frac{\pi}{4} (0.002\text{m})^2 5.67 \times 10^{-8} \text{W} / \text{m}^2 \cdot \text{K}^4 (300\text{K})^4 \\ q_{ap} &= (36.2 + 0.19 + 1443) \mu\text{W} = 1479 \mu\text{W}. \quad < \end{aligned}$$

**COMMENTS:** Note the relative magnitudes of the three radiation components. Also, recognize that the emissivity of the enclosure  $\varepsilon_3$  doesn't enter into the analysis. Why?

### PROBLEM 12.56

**KNOWN:** Spectral, hemispherical absorptivity of an opaque surface.

**FIND:** (a) Solar absorptivity, (b) Total, hemispherical emissivity for  $T_s = 340\text{K}$ .

**SCHEMATIC:**

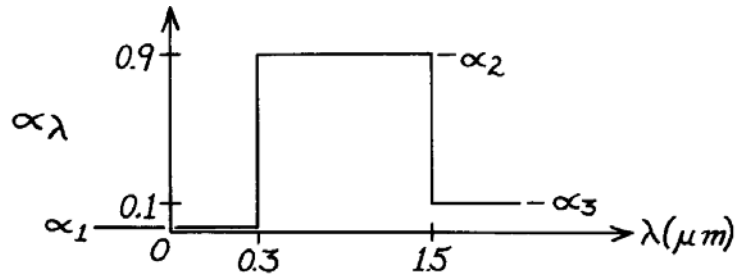

**ASSUMPTIONS:** (1) Surface is opaque, (2)  $\varepsilon_\lambda = \alpha_\lambda$ , (3) Solar spectrum has  $G_\lambda = G_{\lambda,S}$  proportional to  $E_{\lambda,b}(\lambda, 5800\text{K})$ .

**ANALYSIS:** (a) The solar absorptivity follows from Eq. 12.53.

$$\alpha_S = \int_0^\infty \alpha_\lambda(\lambda) E_{\lambda,b}(\lambda, 5800\text{K}) d\lambda / \int_0^\infty E_{\lambda,b}(\lambda, 5800\text{K}) d\lambda.$$

The integral can be written in three parts using  $F_{(0 \rightarrow \lambda)}$  terms.

$$\alpha_S = \alpha_1 F_{(0 \rightarrow 0.3\mu\text{m})} + \alpha_2 \left[ F_{(0 \rightarrow 1.5\mu\text{m})} - F_{(0 \rightarrow 0.3\mu\text{m})} \right] + \alpha_3 \left[ 1 - F_{(0 \rightarrow 1.5\mu\text{m})} \right].$$

From Table 12.1,

$$\begin{aligned} \lambda T = 0.3 \times 5800 &= 1740 \mu\text{m}\cdot\text{K} & F_{(0 \rightarrow 0.3 \mu\text{m})} &= 0.0335 \\ \lambda T = 1.5 \times 5800 &= 8700 \mu\text{m}\cdot\text{K} & F_{(0 \rightarrow 1.5 \mu\text{m})} &= 0.8805. \end{aligned}$$

Hence,

$$\alpha_S = 0 \times 0.0335 + 0.9 [0.8805 - 0.0335] + 0.1 [1 - 0.8805] = 0.774. \quad <$$

(b) The total, hemispherical emissivity for the surface at 340K will be

$$\varepsilon = \int_0^\infty \varepsilon_\lambda(\lambda) E_{\lambda,b}(\lambda, 340\text{K}) d\lambda / E_b(340\text{K}).$$

If  $\varepsilon_\lambda = \alpha_\lambda$ , then using the  $\alpha_\lambda$  distribution above, the integral can be written in terms of  $F_{(0 \rightarrow \lambda)}$  values. It is readily recognized that since

$$F_{(0 \rightarrow 1.5 \mu\text{m}, 340\text{K})} \approx 0.000 \quad \text{at} \quad \lambda T = 1.5 \times 340 = 510 \mu\text{m}\cdot\text{K}$$

there is negligible spectral emissive power below 1.5  $\mu\text{m}$ . It follows then that

$$\varepsilon = \varepsilon_\lambda = \alpha_\lambda = 0.1 \quad <$$

**COMMENTS:** The assumption  $\varepsilon_\lambda = \alpha_\lambda$  can be satisfied if this surface were irradiated diffusely or if the surface itself were diffuse. Note that for this surface under the specified conditions of solar irradiation and surface temperature  $\alpha_S \neq \varepsilon$ . Such a surface is referred to as a spectrally selective surface.

### PROBLEM 12.57

**KNOWN:** Spectral distribution of the absorptivity and irradiation of a surface at 1000 K.

**FIND:** (a) Total, hemispherical absorptivity, (b) Total, hemispherical emissivity, (c) Net radiant flux to the surface.

**SCHEMATIC:**

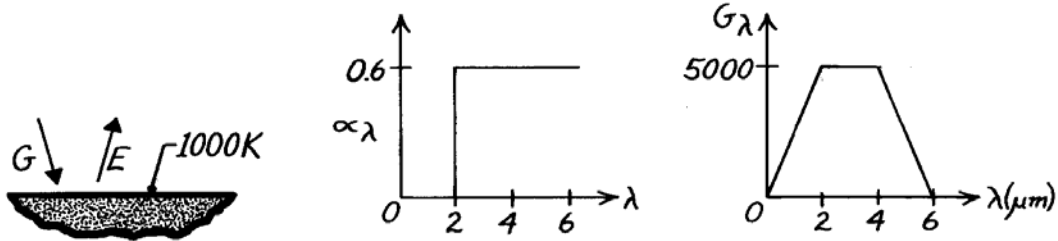

**ASSUMPTIONS:** (1)  $\alpha_\lambda = \varepsilon_\lambda$ .

**ANALYSIS:** (a) From Eq. 12.52,

$$\alpha = \frac{\int_0^\infty \alpha_\lambda G_\lambda d\lambda}{\int_0^\infty G_\lambda d\lambda} = \frac{\int_0^{2\mu\text{m}} \alpha_\lambda G_\lambda d\lambda + \int_2^{4\mu\text{m}} \alpha_\lambda G_\lambda d\lambda + \int_4^{6\mu\text{m}} \alpha_\lambda G_\lambda d\lambda}{\int_0^{2\mu\text{m}} G_\lambda d\lambda + \int_2^{4\mu\text{m}} G_\lambda d\lambda + \int_4^{6\mu\text{m}} G_\lambda d\lambda}$$

$$\alpha = \frac{0 \times 1/2(2-0)5000 + 0.6(4-2)5000 + 0.6 \times 1/2(6-4)5000}{1/2(2-0)5000 + (4-2)(5000) + 1/2(6-4)5000}$$

$$\alpha = \frac{9000}{20,000} = 0.45. \quad <$$

(b) From Eq. 12.43,

$$\varepsilon = \frac{\int_0^\infty \varepsilon_\lambda E_{\lambda,b} d\lambda}{E_b} = \frac{0 \int_0^{2\mu\text{m}} E_{\lambda,b} d\lambda}{E_b} + \frac{0.6 \int_2^\infty E_{\lambda,b} d\lambda}{E_b}$$

$$\varepsilon = 0.6 F_{(2\mu\text{m} \rightarrow \infty)} = 0.6 [1 - F_{(0 \rightarrow 2\mu\text{m})}].$$

From Table 12.1, with  $\lambda T = 2 \mu\text{m} \times 1000\text{K} = 2000 \mu\text{m}\cdot\text{K}$ , find  $F_{(0 \rightarrow 2 \mu\text{m})} = 0.0667$ . Hence,

$$\varepsilon = 0.6 [1 - 0.0667] = 0.56. \quad <$$

(c) The net radiant heat flux to the surface is

$$q''_{\text{rad,net}} = \alpha G - E = \alpha G - \varepsilon \sigma T^4$$

$$q''_{\text{rad,net}} = 0.45 (20,000 \text{ W/m}^2) - 0.56 \times 5.67 \times 10^{-8} \text{ W/m}^2 \cdot \text{K}^4 \times (1000\text{K})^4$$

$$q''_{\text{rad,net}} = (9000 - 31,751) \text{ W/m}^2 = -22,751 \text{ W/m}^2. \quad <$$

### PROBLEM 12.58

**KNOWN:** Spectral distribution of surface absorptivity and irradiation. Surface temperature.

**FIND:** (a) Total absorptivity, (b) Emissive power, (c) Nature of surface temperature change.

**SCHEMATIC:**

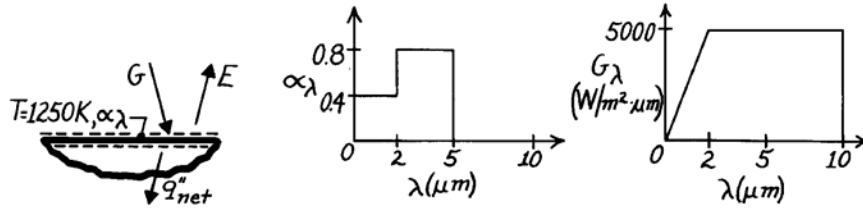

**ASSUMPTIONS:** (1) Opaque, diffuse surface behavior, (2) Convection effects are negligible.

**ANALYSIS:** (a) From Eqs. 12.51 and 12.52, the absorptivity is defined as

$$\alpha \equiv G_{\text{abs}} / G = \int_0^{\infty} \alpha_{\lambda} G_{\lambda} d\lambda / \int_0^{\infty} G_{\lambda} d\lambda.$$

The absorbed irradiation is,

$$G_{\text{abs}} = 0.4 \left( 5000 \text{ W/m}^2 \cdot \mu\text{m} \times 2 \mu\text{m} \right) / 2 + 0.8 \times 5000 \text{ W/m}^2 \cdot \mu\text{m} (5 - 2) \mu\text{m} + 0 = 14,000 \text{ W/m}^2.$$

The irradiation is,

$$G = \left( 2 \mu\text{m} \times 5000 \text{ W/m}^2 \cdot \mu\text{m} \right) / 2 + (10 - 2) \mu\text{m} \times 5000 \text{ W/m}^2 \cdot \mu\text{m} = 45,000 \text{ W/m}^2.$$

Hence,  $\alpha = 14,000 \text{ W/m}^2 / 45,000 \text{ W/m}^2 = 0.311.$  <

(b) From Eq. 12.43, the emissivity is

$$\varepsilon = \int_0^{\infty} \varepsilon_{\lambda} E_{\lambda,b} d\lambda / E_b = 0.4 \int_0^2 E_{\lambda,b} d\lambda / E_b + 0.8 \int_2^5 E_{\lambda,b} d\lambda / E_b$$

From Table 12.1,  $\lambda T = 2 \mu\text{m} \times 1250\text{K} = 2500\text{K}$ ,  $F_{(0-2)} = 0.162$   
 $\lambda T = 5 \mu\text{m} \times 1250\text{K} = 6250\text{K}$ ,  $F_{(0-5)} = 0.757.$

Hence,  $\varepsilon = 0.4 \times 0.162 + 0.8(0.757 - 0.162) = 0.54.$

$$E = \varepsilon E_b = \varepsilon \sigma T^4 = 0.54 \times 5.67 \times 10^{-8} \text{ W/m}^2 \cdot \text{K}^4 (1250\text{K})^4 = 74,751 \text{ W/m}^2. \quad <$$

(c) From an energy balance on the surface, the net heat flux *to* the surface is

$$q''_{\text{net}} = \alpha G - E = (14,000 - 74,751) \text{ W/m}^2 = -60,751 \text{ W/m}^2.$$

Hence the temperature of the surface is *decreasing*. <

**COMMENTS:** Note that  $\alpha \neq \varepsilon$ . Hence the surface is not gray for the prescribed conditions.

### PROBLEM 12.59

**KNOWN:** Spectral emissivity of an opaque, diffuse surface.

**FIND:** (a) Total, hemispherical emissivity of the surface when maintained at 1000 K, (b) Total, hemispherical absorptivity when irradiated by large surroundings of emissivity 0.8 and temperature 1500 K, (c) Radiosity when maintained at 1000 K and irradiated as prescribed in part (b), (d) Net radiation flux into surface for conditions of part (c), and (e) Compute and plot each of the parameters of parts (a)-(c) as a function of the surface temperature  $T_s$  for the range  $750 < T_s \leq 2000$  K.

**SCHEMATIC:**

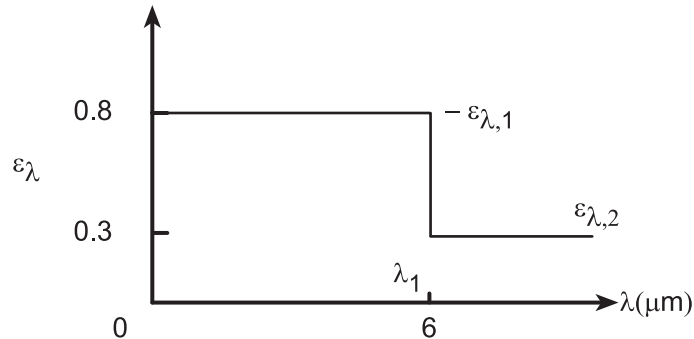

**ASSUMPTIONS:** (1) Surface is opaque, diffuse, and (2) Surroundings are large compared to the surface.

**ANALYSIS:** (a) When the surface is maintained at 1000 K, the total, hemispherical emissivity is evaluated from Eq. 12.43 written as

$$\begin{aligned}\varepsilon &= \int_0^{\infty} \varepsilon_{\lambda} E_{\lambda,b}(T) d\lambda / E_b(T) = \varepsilon_{\lambda,1} \int_0^{\lambda_1} E_{\lambda,b}(T) d\lambda / E_b(T) + \varepsilon_{\lambda,2} \int_{\lambda_1}^{\infty} E_{\lambda,b}(T) d\lambda / E_b(T) \\ \varepsilon &= \varepsilon_{\lambda,1} F_{(0-\lambda_1)T} + \varepsilon_{\lambda,2} (1 - F_{(0-\lambda_1)T})\end{aligned}$$

where for  $\lambda T = 6 \mu\text{m} \times 1000 \text{ K} = 6000 \mu\text{m}\cdot\text{K}$ , from Table 12.1, find  $F_{0-\lambda T} = 0.738$ . Hence,

$$\varepsilon = 0.8 \times 0.738 + 0.3(1 - 0.738) = 0.669. \quad <$$

(b) When the surface is irradiated by large surroundings at  $T_{\text{sur}} = 1500 \text{ K}$ ,  $G = E_b(T_{\text{sur}})$ . From Eq. 12.52,

$$\begin{aligned}\alpha &= \int_0^{\infty} \alpha_{\lambda} G_{\lambda} d\lambda / \int_0^{\infty} G_{\lambda} d\lambda = \int_0^{\infty} \varepsilon_{\lambda} E_{\lambda,b}(T_{\text{sur}}) d\lambda / E_b(T_{\text{sur}}) \\ \alpha &= \varepsilon_{\lambda,1} F_{(0-\lambda_1)T_{\text{sur}}} + \varepsilon_{\lambda,2} (1 - F_{(0-\lambda_1)T_{\text{sur}}})\end{aligned}$$

where for  $\lambda_1 T_{\text{sur}} = 6 \mu\text{m} \times 1500 \text{ K} = 9000 \mu\text{m}\cdot\text{K}$ , from Table 12.1, find  $F_{(0-\lambda T)} = 0.890$ . Hence,

$$\alpha = 0.8 \times 0.890 + 0.3(1 - 0.890) = 0.745. \quad <$$

Note that  $\alpha_{\lambda} = \varepsilon_{\lambda}$  for all conditions and the emissivity of the surroundings is irrelevant.

(c) The radiosity for the surface maintained at 1000 K and irradiated as in part (b) is

$$\begin{aligned}J &= \varepsilon E_b(T) + \rho G = \varepsilon E_b(T) + (1 - \alpha) E_b(T_{\text{sur}}) \\ J &= 0.669 \times 5.67 \times 10^{-8} \text{ W/m}^2 \cdot \text{K}^4 (1000 \text{ K})^4 + (1 - 0.745) 5.67 \times 10^{-8} \text{ W/m}^2 \cdot \text{K}^4 (1500 \text{ K})^4 \\ J &= (37,932 + 73,196) \text{ W/m}^2 = 111,128 \text{ W/m}^2 \quad <\end{aligned}$$

Continued...

### PROBLEM 12.59 (Cont.)

(d) The net radiation flux into the surface with  $G = \sigma T_{\text{sur}}^4$  is

$$q''_{\text{rad,in}} = \alpha G - \varepsilon E_b(T) = G - J$$

$$q''_{\text{rad,in}} = 5.67 \times 10^{-8} \text{ W/m}^2 \cdot \text{K} (1500 \text{ K})^4 - 111,128 \text{ W/m}^2$$

$$q''_{\text{rad,in}} = 175,915 \text{ W/m}^2.$$

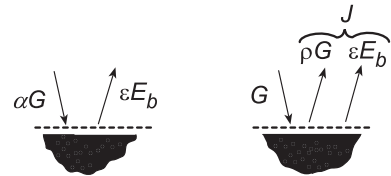

(e) The foregoing equations were entered into the IHT workspace along with the *IHT Radiation Tool*, *Band Emission Factor*, to evaluate  $F_{(0-\lambda T)}$  values and the respective parameters for parts (a)-(d) were computed and are plotted below.

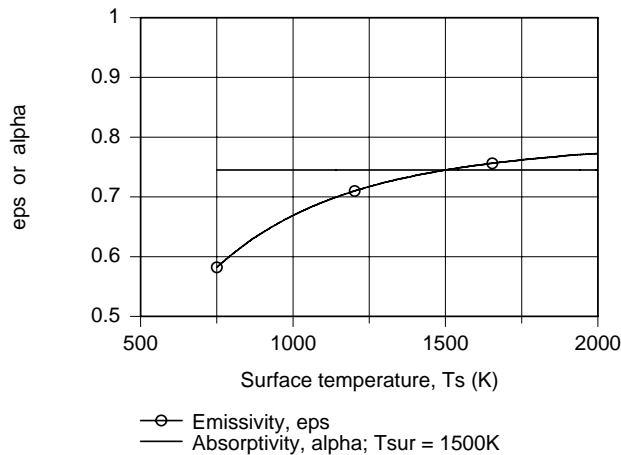

Note that the absorptivity,  $\alpha = \alpha(\alpha_\lambda, T_{\text{sur}})$ , remains constant as  $T_s$  changes since it is a function of  $\alpha_\lambda$  (or  $\varepsilon_\lambda$ ) and  $T_{\text{sur}}$  only. The emissivity  $\varepsilon = \varepsilon(\varepsilon_\lambda, T_s)$  is a function of  $T_s$  and increases as  $T_s$  increases. Could you have surmised as much by looking at the spectral emissivity distribution? At what condition is  $\varepsilon = \alpha$ ?

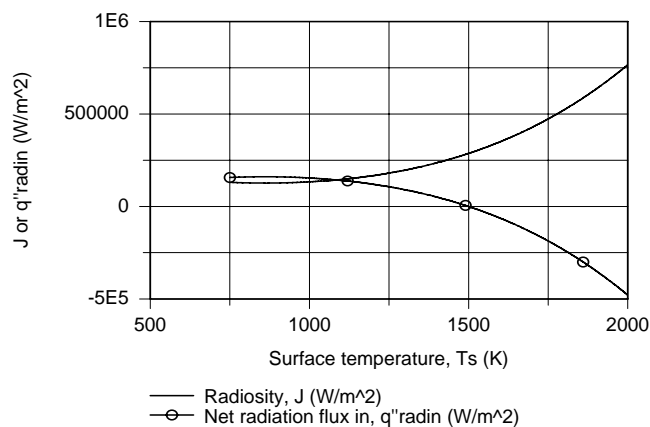

The radiosity,  $J_1$  increases with increasing  $T_s$  since  $E_b(T)$  increases markedly with temperature; the reflected irradiation,  $(1 - \alpha)E_b(T_{\text{sur}})$  decreases only slightly as  $T_s$  increases compared to  $E_b(T)$ . Since  $G$  is independent of  $T_s$ , it follows that the variation of  $q''_{\text{rad,in}}$  will be due to the radiosity change; note the sign difference.

**COMMENTS:** We didn't use the emissivity of the surroundings ( $\varepsilon = 0.8$ ) to determine the irradiation onto the surface. Why?

### PROBLEM 12.60

**KNOWN:** Furnace wall temperature and aperture diameter. Distance of detector from aperture and orientation of detector relative to aperture.

**FIND:** (a) Rate at which radiation from the furnace is intercepted by the detector, (b) Effect of aperture window of prescribed spectral transmissivity on the radiation interception rate.

**SCHEMATIC:**

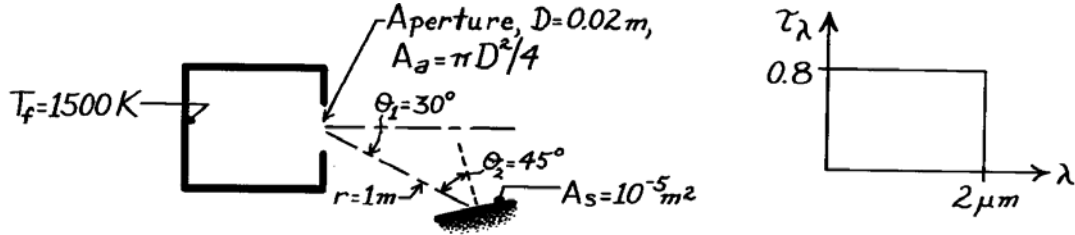

**ASSUMPTIONS:** (1) Radiation emerging from aperture has characteristics of emission from a blackbody, (2) Cover material is diffuse, (3) Aperture and detector surface may be approximated as infinitesimally small.

**ANALYSIS:** (a) From Eq. 12.12, the heat rate leaving the furnace aperture and intercepted by the detector is

$$q = I_e A_a \cos \theta_1 \omega_{s-a}$$

From Eqs. 12.17 and 12.32

$$I_e = \frac{E_b(T_f)}{\pi} = \frac{\sigma T_f^4}{\pi} = \frac{5.67 \times 10^{-8} (1500)^4}{\pi} = 9.14 \times 10^4 \text{ W/m}^2 \cdot \text{sr}.$$

From Eq. 12.7,

$$\omega_{s-a} = \frac{A_n}{r^2} = \frac{A_s \cdot \cos \theta_2}{r^2} = \frac{10^{-5} \text{ m}^2 \times \cos 45^\circ}{(1 \text{ m})^2} = 0.707 \times 10^{-5} \text{ sr}.$$

Hence

$$q = 9.14 \times 10^4 \text{ W/m}^2 \cdot \text{sr} \left[ \pi (0.02 \text{ m})^2 / 4 \right] \cos 30^\circ \times 0.707 \times 10^{-5} \text{ sr} = 1.76 \times 10^{-4} \text{ W}. <$$

(b) With the window, the heat rate is

$$q = \tau (I_e A_a \cos \theta_1 \omega_{s-a})$$

where  $\tau$  is the transmissivity of the window to radiation emitted by the furnace wall. From Eq. 12.61,

$$\tau = \frac{\int_0^\infty \tau_\lambda G_\lambda d\lambda}{\int_0^\infty G_\lambda d\lambda} = \frac{\int_0^\infty \tau_\lambda E_{\lambda,b}(T_f) d\lambda}{\int_0^\infty E_{\lambda,b} d\lambda} = 0.8 \int_0^2 (E_{\lambda,b} / E_b) d\lambda = 0.8 F_{(0 \rightarrow 2 \mu\text{m})}.$$

With  $\lambda T = 2 \mu\text{m} \times 1500 \text{ K} = 3000 \mu\text{m} \cdot \text{K}$ , Table 12.1 gives  $F_{(0 \rightarrow 2 \mu\text{m})} = 0.273$ . Hence, with  $\tau = 0.273 \times 0.8 = 0.218$ , find

$$q = 0.218 \times 1.76 \times 10^{-4} \text{ W} = 0.384 \times 10^{-4} \text{ W}. <$$

## PROBLEM 12.61

**KNOWN:** Approximate spectral transmissivity of 1-mm thick liquid water layer.

**FIND:** (a) Transmissivity of a 1-mm thick water layer adjacent to surface at the critical temperature ( $T_s = 647.3 \text{ K}$ ), (b) Transmissivity of a 1-mm thick water layer subject to irradiation from a melting platinum wire ( $T_s = 2045 \text{ K}$ ), (c) Transmissivity of a 1-mm thick water layer subject to solar irradiation at  $T_s = 5800 \text{ K}$ .

**SCHEMATIC:**

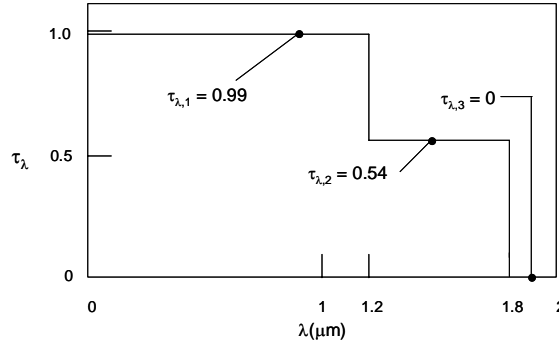

**ASSUMPTIONS:** Irradiation is proportional to that of a blackbody.

**ANALYSIS:** From Eq. 12.61 and incorporating the assumption, the transmissivity is expressed as

$$\tau = \frac{\int_0^{\infty} \tau_{\lambda} E_{\lambda,b} d\lambda}{E_b} = \frac{\tau_{\lambda,1} \int_0^{1.2} E_{\lambda,b} d\lambda}{E_b} + \frac{\tau_{\lambda,2} \int_{1.2}^{1.8} E_{\lambda,b} d\lambda}{E_b} + \frac{\tau_{\lambda,3} \int_{1.8}^{\infty} E_{\lambda,b} d\lambda}{E_b} \quad \text{or}$$

$$\tau = \tau_{\lambda,1} F_{(0-1.2\mu\text{m})} + \tau_{\lambda,2} F_{(1.2-1.8\mu\text{m})} + \tau_{\lambda,3} F_{(1.8\mu\text{m}-\infty)}$$

where  $F_{(1.2-1.8\mu\text{m})} = F_{(0-1.8\mu\text{m})} - F_{(0-1.2\mu\text{m})}$  and  $F_{(1.8\mu\text{m}-\infty)} = 1 - F_{(0-1.2\mu\text{m})} - F_{(1.2-1.8\mu\text{m})}$

(a) For a source temperature of 647.3 K,

$$F_{(0-1.2\mu\text{m})} = 1.414 \times 10^{-5}, \quad F_{(0-1.8\mu\text{m})} = 0.001818$$

$$\tau = 0.99 \times 1.414 \times 10^{-5} + 0.54 \times (0.001818 - 1.414 \times 10^{-5}) = 0.00099 \quad <$$

(b) For a source temperature of 2045 K,

$$F_{(0-1.2\mu\text{m})} = 0.1518, \quad F_{(0-1.8\mu\text{m})} = 0.4197$$

$$\tau = 0.99 \times 0.1518 + 0.54 \times (0.4197 - 0.1518) = 0.295 \quad <$$

(c) For a source temperature of 5800 K,

$$F_{(0-1.2\mu\text{m})} = 0.8057, \quad F_{(0-1.8\mu\text{m})} = 0.9226$$

$$\tau = 0.99 \times 0.8057 + 0.54 \times (0.9226 - 0.8057) = 0.861 \quad <$$

**COMMENTS:** Liquid water may be treated as opaque for most engineering applications. Exceptions include applications involving solar irradiation, irradiation from very high temperature plasmas that can achieve temperatures at tens of thousands of kelvins, and situations involving very thin layers of liquid water.



## PROBLEM 12.62

**KNOWN:** Spectral transmissivity of a plain and tinted glass.

**FIND:** (a) Solar energy transmitted by each glass, (b) Visible radiant energy transmitted by each with solar irradiation.

**SCHEMATIC:**

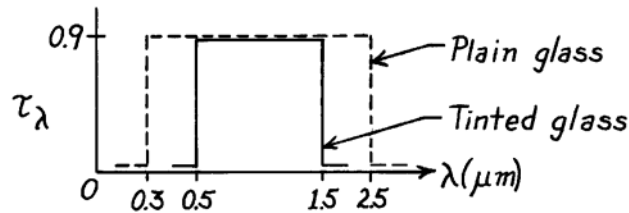

**ASSUMPTIONS:** (1) Spectral distribution of solar irradiation is proportional to spectral emissive power of a blackbody at 5800K.

**ANALYSIS:** To compare the energy transmitted by the glasses, it is sufficient to calculate the transmissivity of each glass for the prescribed spectral range when the irradiation distribution is that of the solar spectrum. From Eq. 12.61,

$$\tau_S = \int_0^{\infty} \tau_{\lambda} \cdot G_{\lambda, S} d\lambda / \int_0^{\infty} G_{\lambda, S} d\lambda = \int_0^{\infty} \tau_{\lambda} \cdot E_{\lambda, b}(\lambda, 5800\text{K}) d\lambda / E_b(5800\text{K}).$$

Recognizing that  $\tau_{\lambda}$  will be constant for the range  $\lambda_1 \rightarrow \lambda_2$ , using Eq. 12.29, find

$$\tau_S = \tau_{\lambda} \cdot F(\lambda_1 \rightarrow \lambda_2) = \tau_{\lambda} \left[ F(0 \rightarrow \lambda_2) - F(0 \rightarrow \lambda_1) \right].$$

(a) For the two glasses, the solar transmissivity, using Table 12.1 for F, is then

<i>Plain glass:</i>	$\lambda_2 = 2.5 \mu\text{m}$	$\lambda_2 T = 2.5 \mu\text{m} \times 5800\text{K} = 14,500 \mu\text{m}\cdot\text{K}$	$F(0 \rightarrow \lambda_2) = 0.966$
	$\lambda_1 = 0.3 \mu\text{m}$	$\lambda_1 T = 0.3 \mu\text{m} \times 5800\text{K} = 1,740 \mu\text{m}\cdot\text{K}$	$F(0 \rightarrow \lambda_1) = 0.033$

$$\tau_S = 0.9 [0.966 - 0.033] = 0.839. \quad <$$

<i>Tinted glass:</i>	$\lambda_2 = 1.5 \mu\text{m}$	$\lambda_2 T = 1.5 \mu\text{m} \times 5800\text{K} = 8,700 \mu\text{m}\cdot\text{K}$	$F(0 \rightarrow \lambda_2) = 0.881$
	$\lambda_1 = 0.5 \mu\text{m}$	$\lambda_1 T = 0.5 \mu\text{m} \times 5800\text{K} = 2,900 \mu\text{m}\cdot\text{K}$	$F(0 \rightarrow \lambda_1) = 0.250$

$$\tau_S = 0.9 [0.881 - 0.250] = 0.568. \quad <$$

(b) The limits of the visible spectrum are  $\lambda_1 = 0.4$  and  $\lambda_2 = 0.7 \mu\text{m}$ . For the tinted glass,  $\lambda_1 = 0.5 \mu\text{m}$  rather than  $0.4 \mu\text{m}$ . From Table 12.1,

$\lambda_2 = 0.7 \mu\text{m}$	$\lambda_2 T = 0.7 \mu\text{m} \times 5800\text{K} = 4,060 \mu\text{m}\cdot\text{K}$	$F(0 \rightarrow \lambda_2) = 0.491$
$\lambda_1 = 0.5 \mu\text{m}$	$\lambda_1 T = 0.5 \mu\text{m} \times 5800\text{K} = 2,900 \mu\text{m}\cdot\text{K}$	$F(0 \rightarrow \lambda_1) = 0.250$
$\lambda_1 = 0.4 \mu\text{m}$	$\lambda_1 T = 0.4 \mu\text{m} \times 5800\text{K} = 2,320 \mu\text{m}\cdot\text{K}$	$F(0 \rightarrow \lambda_1) = 0.125$

<i>Plain glass:</i>	$\tau_{\text{vis}} = 0.9 [0.491 - 0.125] = 0.329$	<
---------------------	---	---

<i>Tinted glass:</i>	$\tau_{\text{vis}} = 0.9 [0.491 - 0.250] = 0.217$	<
----------------------	---	---

**COMMENTS:** For solar energy, the transmissivities are 0.839 for the plain glass vs. 0.568 for the tinted glass. Within the visible region,  $\tau_{\text{vis}}$  is 0.329 vs. 0.217. Tinting reduces solar flux by 32% and visible solar flux by 34%.

### PROBLEM 12.63

**KNOWN:** Spectral transmissivity of low iron glass (see Fig. 12.23).

**FIND:** Interpretation of the greenhouse effect.

**SCHEMATIC:**

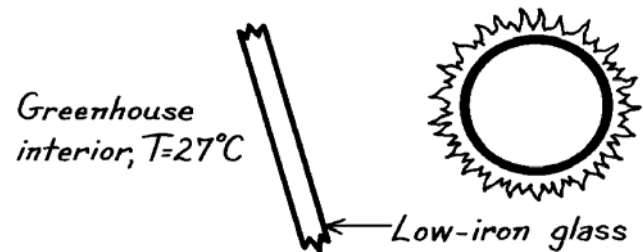

**ANALYSIS:** The glass affects the net radiation transfer to the contents of the greenhouse. Since most of the solar radiation is in the spectral region  $\lambda < 3 \mu\text{m}$ , the glass will transmit a large fraction of this radiation. However, the contents of the greenhouse, being at a comparatively low temperature, emit most of their radiation in the medium to far infrared. This radiation is not transmitted by the glass. Hence the glass allows short wavelength solar radiation to enter the greenhouse, but does not permit long wavelength radiation to leave.

## PROBLEM 12.64

**KNOWN:** Spectrally selective, diffuse surface exposed to solar irradiation.

**FIND:** (a) Spectral transmissivity,  $\tau_\lambda$ , (b) Transmissivity,  $\tau_S$ , reflectivity,  $\rho_S$ , and absorptivity,  $\alpha_S$ , for solar irradiation, (c) Emissivity,  $\varepsilon$ , when surface is at  $T_s = 350\text{K}$ , (d) Net heat flux by radiation to the surface.

**SCHEMATIC:**



**ASSUMPTIONS:** (1) Surface is diffuse, (2) Spectral distribution of solar irradiation is proportional to  $E_{\lambda,b}(\lambda, 5800\text{K})$ .

**ANALYSIS:** (a) Conservation of radiant energy requires, according to Eq. 12.54, that  $\rho_\lambda + \alpha_\lambda + \tau_\lambda = 1$  or  $\tau_\lambda = 1 - \rho_\lambda - \alpha_\lambda$ . Hence, the spectral transmissivity appears as shown above (dashed line). Note that the surface is opaque for  $\lambda > 1.38 \mu\text{m}$ .

(b) The transmissivity to solar irradiation,  $G_S$ , follows from Eq. 12.61,

$$\tau_S = \int_0^\infty \tau_\lambda G_{\lambda,S} d\lambda / G_S = \int_0^\infty \tau_\lambda E_{\lambda,b}(\lambda, 5800\text{K}) d\lambda / E_b(5800\text{K})$$

$$\tau_S = \tau_{\lambda,b} \int_0^{1.38} E_{\lambda,b}(\lambda, 5800\text{K}) d\lambda / E_b(5800\text{K}) = \tau_{\lambda,1} F_{(0 \rightarrow \lambda_1)} = 0.7 \times 0.856 = 0.599 \quad <$$

where  $\lambda_1 T_S = 1.38 \times 5800 = 8000 \mu\text{m}\cdot\text{K}$  and from Table 12.1,  $F_{(0 \rightarrow \lambda_1)} = 0.856$ . From Eqs. 12.58 and 12.63,

$$\rho_S = \int_0^\infty \rho_\lambda G_{\lambda,S} d\lambda / G_S = \rho_{\lambda,1} F_{(0 \rightarrow \lambda_1)} = 0.1 \times 0.856 = 0.086 \quad <$$

$$\alpha_S = 1 - \rho_S - \tau_S = 1 - 0.086 - 0.599 = 0.315. \quad <$$

(c) For the surface at  $T_s = 350\text{K}$ , the emissivity can be determined from Eq. 12.43. Since the surface is diffuse, according to Eq. 12.67,  $\alpha_\lambda = \varepsilon_\lambda$ , the expression has the form

$$\varepsilon = \int_0^\infty \varepsilon_\lambda E_{\lambda,b}(T_s) d\lambda / E_b(T_s) = \int_0^\infty \alpha_\lambda E_{\lambda,b}(350\text{K}) d\lambda / E_b(350\text{K})$$

$$\varepsilon = \alpha_{\lambda,1} F_{(0-1.38 \mu\text{m})} + \alpha_{\lambda,2} [1 - F_{(0-1.38 \mu\text{m})}] = \alpha_{\lambda,2} = 1 \quad <$$

where from Table 12.1 with  $\lambda_1 T_s = 1.38 \times 350 = 483 \mu\text{m}\cdot\text{K}$ ,  $F_{(0-\lambda T)} \approx 0$ .

(d) The net heat flux by radiation to the surface is determined by a radiation balance

$$q''_{\text{rad}} = G_S - \rho_S G_S - \tau_S G_S - E$$

$$q''_{\text{rad}} = \alpha_S G_S - E$$

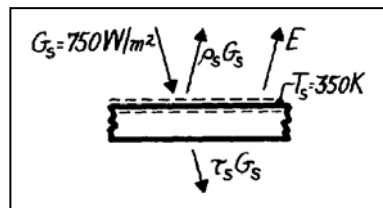

$$q''_{\text{rad}} = 0.315 \times 750 \text{ W/m}^2 - 1.0 \times 5.67 \times 10^{-8} \text{ W/m}^2 \cdot \text{K}^4 (350\text{K})^4 = -615 \text{ W/m}^2. \quad <$$

## PROBLEM 12.65

**KNOWN:** Large furnace with diffuse, opaque walls ( $T_f$ ,  $\varepsilon_f$ ) and a small diffuse, spectrally selective object ( $T_o$ ,  $\tau_\lambda$ ,  $\rho_\lambda$ ).

**FIND:** For points on the furnace wall and the object, find  $\varepsilon$ ,  $\alpha$ ,  $E$ ,  $G$  and  $J$ .

**SCHEMATIC:**



**ASSUMPTIONS:** (1) Furnace walls are isothermal, diffuse, and gray, (2) Object is isothermal and diffuse.

**ANALYSIS:** Consider first the furnace wall (A). Since the wall material is diffuse and gray, it follows that

$$\varepsilon_A = \varepsilon_f = \alpha_A = 0.85. \quad <$$

The emissive power is

$$E_A = \varepsilon_A E_b(T_f) = \varepsilon_A \sigma T_f^4 = 0.85 \times 5.67 \times 10^{-8} \text{ W/m}^2 \cdot \text{K}^4 (3000 \text{ K})^4 = 3.904 \times 10^6 \text{ W/m}^2. \quad <$$

Since the furnace is an isothermal enclosure, blackbody conditions exist such that

$$G_A = J_A = E_b(T_f) = \sigma T_f^4 = 5.67 \times 10^{-8} \text{ W/m}^2 \cdot \text{K}^4 (3000 \text{ K})^4 = 4.593 \times 10^6 \text{ W/m}^2. \quad <$$

Considering now the semitransparent, diffuse, spectrally selective object at  $T_o = 300 \text{ K}$ . From the radiation balance requirement, find

$$\alpha_\lambda = 1 - \rho_\lambda - \tau_\lambda \quad \text{or} \quad \alpha_1 = 1 - 0.6 - 0.3 = 0.1 \quad \text{and} \quad \alpha_2 = 1 - 0.7 - 0.0 = 0.3$$

$$\alpha_B = \int_0^\infty \alpha_\lambda G_\lambda d\lambda / G = F_{0-\lambda T} \cdot \alpha_1 + (1 - F_{0-\lambda T}) \cdot \alpha_2 = 0.970 \times 0.1 + (1 - 0.970) \times 0.3 = 0.106 \quad <$$

where  $F_{0-\lambda T} = 0.970$  at  $\lambda T = 5 \mu\text{m} \times 3000 \text{ K} = 15,000 \mu\text{m} \cdot \text{K}$  since  $G = E_b(T_f)$ . Since the object is diffuse,  $\varepsilon_\lambda = \alpha_\lambda$ , hence

$$\varepsilon_B = \int_0^\infty \varepsilon_\lambda E_{\lambda,b}(T_o) d\lambda / E_{b,o} = F_{0-\lambda T} \alpha_1 + (1 - F_{0-\lambda T}) \cdot \alpha_2 = 0.0138 \times 0.1 + (1 - 0.0138) \times 0.3 = 0.297 \quad <$$

where  $F_{0-\lambda T} = 0.0138$  at  $\lambda T = 5 \mu\text{m} \times 300 \text{ K} = 1500 \mu\text{m} \cdot \text{K}$ . The emissive power is

$$E_B = \varepsilon_B E_{b,B}(T_o) = 0.297 \times 5.67 \times 10^{-8} \text{ W/m}^2 \cdot \text{K}^4 (300 \text{ K})^4 = 136.5 \text{ W/m}^2. \quad <$$

The irradiation is that due to the large furnace for which blackbody conditions exist,

$$G_B = G_A = \sigma T_f^4 = 4.593 \times 10^6 \text{ W/m}^2. \quad <$$

The radiosity leaving point B is due to emission and reflected irradiation,

$$J_B = E_B + \rho_B G_B = 136.5 \text{ W/m}^2 + 0.3 \times 4.593 \times 10^6 \text{ W/m}^2 = 1.378 \times 10^6 \text{ W/m}^2. \quad <$$

If we include transmitted irradiation,  $J_B = E_B + (\rho_B + \tau_B) G_B = E_B + (1 - \alpha_B) G_B = 4.106 \times 10^6 \text{ W/m}^2$ .

In the first calculation, note how we set  $\rho_B \approx \rho_\lambda (\lambda < 5 \mu\text{m})$ .

### PROBLEM 12.66

**KNOWN:** Spectral characteristics of four diffuse surfaces exposed to solar radiation.

**FIND:** Surfaces which may be assumed to be gray.

**SCHEMATIC:**

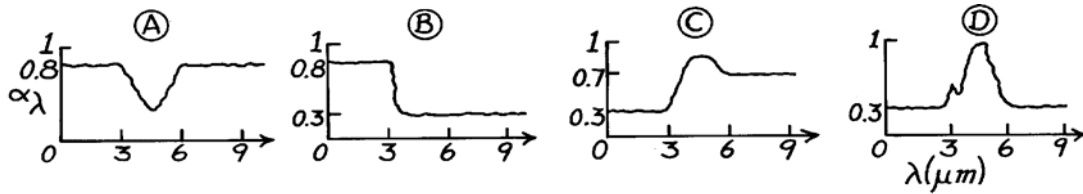

**ASSUMPTIONS:** (1) Diffuse surface behavior.

**ANALYSIS:** A gray surface is one for which  $\alpha_\lambda$  and  $\varepsilon_\lambda$  are constant over the spectral regions of the irradiation and the surface emission.

For  $\lambda = 3 \mu\text{m}$  and  $T = 5800\text{K}$ ,  $\lambda T = 17,400 \mu\text{m}\cdot\text{K}$  and from Table 12.1, find  $F_{(0 \rightarrow \lambda)} = 0.984$ . Hence, 98.4% of the solar radiation is in the spectral region below  $3 \mu\text{m}$ .

For  $\lambda = 6 \mu\text{m}$  and  $T = 300\text{K}$ ,  $\lambda T = 1800 \mu\text{m}\cdot\text{K}$  and from Table 12.1, find  $F_{(0 \rightarrow \lambda)} = 0.039$ . Hence, 96.1% of the surface emission is in the spectral region above  $6 \mu\text{m}$ .

Hence:	Surface A is gray:	$\alpha_S \approx \varepsilon = 0.8$	<
	Surface B is not gray:	$\alpha_S \approx 0.8, \varepsilon \approx 0.3$	<
	Surface C is not gray:	$\alpha_S \approx 0.3, \varepsilon \approx 0.7$	<
	Surface D is gray:	$\alpha_S \approx \varepsilon = 0.3$ .	<

### PROBLEM 12.67

**KNOWN:** A gray, but directionally selective, material with  $\alpha(\theta, \phi) = 0.5(1 - \cos\phi)$ .

**FIND:** (a) Hemispherical absorptivity when irradiated with collimated solar flux in the direction ( $\theta = 45^\circ$  and  $\phi = 0^\circ$ ) and (b) Hemispherical emissivity of the material.

**SCHEMATIC:**

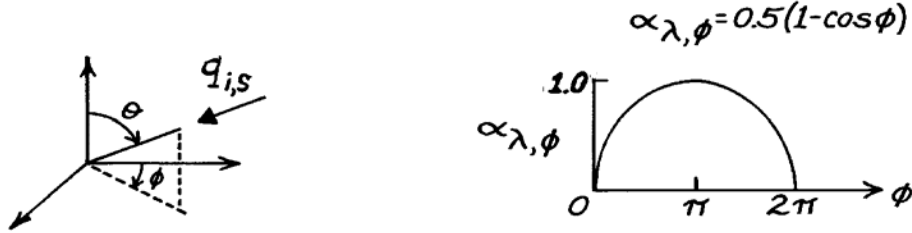

**ASSUMPTIONS:** (1) Gray surface behavior.

**ANALYSIS:** (a) The surface has the directional absorptivity given as

$$\alpha(\theta, \phi) = \alpha_{\lambda, \phi} = 0.5[1 - \cos\phi].$$

When irradiated in the direction  $\theta = 45^\circ$  and  $\phi = 0^\circ$ , the directional absorptivity for this condition is

$$\alpha(45^\circ, 0^\circ) = 0.5[1 - \cos(0^\circ)] = 0. \quad <$$

That is, the surface is completely reflecting (or transmitting) for irradiation in this direction.

(b) From Kirchhoff's law, Eq. 12.68

$$\alpha_{\theta, \phi} = \varepsilon_{\theta, \phi}$$

so that

$$\varepsilon_{\theta, \phi} = \alpha_{\theta, \phi} = 0.5(1 - \cos\phi).$$

Using Eq. 12.41 find

$$\varepsilon = \frac{\int_0^{2\pi} \int_0^{\pi/2} \varepsilon_{\theta, \phi, \lambda} \cos\theta \sin\theta d\theta d\phi}{\int_0^{2\pi} \int_0^{\pi/2} \cos\theta \sin\theta d\theta d\phi}$$

$$\varepsilon = \frac{\int_0^{2\pi} 0.5(1 - \cos\phi) d\phi}{\int_0^{2\pi} d\phi} = \frac{0.5(\phi - \sin\phi)}{2\pi} \Bigg|_0^{2\pi} = 0.5. \quad <$$

## PROBLEM 12.68

**KNOWN:** Approximate spectral transmissivity of polymer film over the range  $2.5 \mu\text{m} \leq \lambda \leq 15 \mu\text{m}$ .

**FIND:** (a) Maximum possible total transmissivity for irradiation from blackbody at  $30^\circ\text{C}$ , (b) Minimum possible total transmissivity for irradiation from blackbody at  $30^\circ\text{C}$ , (c) Maximum and minimum possible total transmissivities for a source temperature of  $600^\circ\text{C}$ .

**SCHEMATIC:**

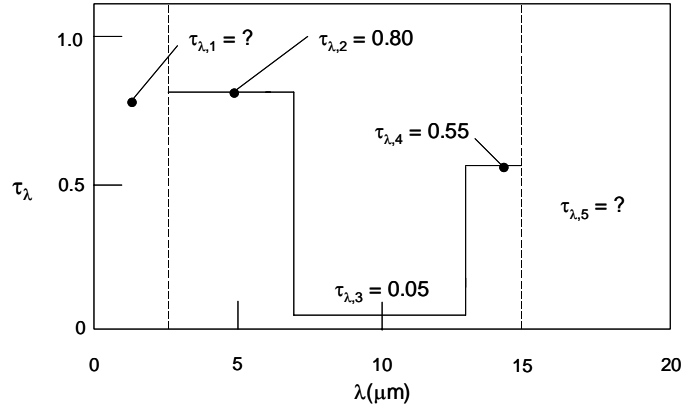

**ASSUMPTIONS:** (1) Irradiation is proportional to that of a blackbody.

**ANALYSIS:** (a) The maximum possible total transmissivity is associated with  $\tau_{\lambda,1} = \tau_{\lambda,5} = 1$ . From Eq. 12.61 and incorporating the assumption, the total transmissivity is written as

$$\tau = \frac{\int_0^{\infty} \tau_{\lambda} E_{\lambda,b} d\lambda}{E_b} = \frac{\tau_{\lambda,1} \int_0^{2.5} E_{\lambda,b} d\lambda}{E_b} + \frac{\tau_{\lambda,2} \int_{2.5}^7 E_{\lambda,b} d\lambda}{E_b} + \frac{\tau_{\lambda,3} \int_7^{13} E_{\lambda,b} d\lambda}{E_b} + \frac{\tau_{\lambda,4} \int_{13}^{15} E_{\lambda,b} d\lambda}{E_b} + \frac{\tau_{\lambda,5} \int_{15}^{\infty} E_{\lambda,b} d\lambda}{E_b}$$

or

$$\tau = \tau_{\lambda,1} F_{(0-2.5\mu\text{m})} + \tau_{\lambda,2} F_{(2.5-7\mu\text{m})} + \tau_{\lambda,3} F_{(7-13\mu\text{m})} + \tau_{\lambda,4} F_{(13-15\mu\text{m})} + \tau_{\lambda,5} F_{(15\mu\text{m}-\infty)}$$

where, at  $T_s = 30^\circ\text{C} + 273 \text{ K} = 303 \text{ K}$ ,

$$F_{(2.5-7\mu\text{m})} = F_{(0-7\mu\text{m})} - F_{(0-2.5\mu\text{m})} = 0.08739 - 1.26 \times 10^{-5} = 0.08738$$

$$F_{(7-13\mu\text{m})} = F_{(0-13\mu\text{m})} - F_{(0-7\mu\text{m})} = 0.4694 - 0.008739 = 0.3820$$

$$F_{(13-15\mu\text{m})} = F_{(0-15\mu\text{m})} - F_{(0-13\mu\text{m})} = 0.5709 - 0.4694 = 0.1015$$

$$F_{(15\mu\text{m}-\infty)} = 1 - F_{(0-15\mu\text{m})} = 1 - 0.5709 = 0.4291$$

Therefore,

Continued...

### PROBLEM 12.68 (Cont.)

$$\tau_{\max} = 1 \times 1.26 \times 10^{-5} + 0.80 \times 0.08738 + 0.05 \times 0.3820 + 0.55 \times 0.1015 + 1 \times 0.4291 = 0.574 <$$

(b) The minimum possible total transmissivity is associated with  $\tau_{\lambda,1} = \tau_{\lambda,5} = 0$ . Hence,

$$\tau_{\min} = 0 \times 1.26 \times 10^{-5} + 0.80 \times 0.08738 + 0.05 \times 0.3820 + 0.55 \times 0.1015 + 0 \times 0.4291 = 0.145 <$$

(c) at  $T_s = 600^\circ\text{C} + 273 \text{ K} = 873 \text{ K}$ ,

$$F_{(2.5-7\mu\text{m})} = F_{(0-7\mu\text{m})} - F_{(0-2.5\mu\text{m})} = 0.7469 - 0.0979 = 0.6490$$

$$F_{(7-13\mu\text{m})} = F_{(0-13\mu\text{m})} - F_{(0-7\mu\text{m})} = 0.9375 - 0.7469 = 0.1906$$

$$F_{(13-15\mu\text{m})} = F_{(0-15\mu\text{m})} - F_{(0-13\mu\text{m})} = 0.9559 - 0.9375 = 0.0184$$

$$F_{(15\mu\text{m}-\infty)} = 1 - F_{(0-15\mu\text{m})} = 1 - 0.9559 = 0.0441$$

Therefore,

$$\tau_{\max} = 1 \times 0.0979 + 0.80 \times 0.6490 + 0.05 \times 0.1906 + 0.55 \times 0.0184 + 1 \times 0.0441 = 0.681 <$$

The minimum possible total transmissivity is associated with  $\tau_{\lambda,1} = \tau_{\lambda,5} = 0$ . Hence,

$$\tau_{\min} = 0 \times 0.0979 + 0.80 \times 0.6490 + 0.05 \times 0.1906 + 0.55 \times 0.0184 + 0 \times 0.0441 = 0.539 <$$

**COMMENTS:** (1) For irradiation from the low temperature source, 43% of the irradiation is in the wavelength range greater than  $15 \mu\text{m}$ . Since the spectral transmissivity is not known in this wavelength range, there is a very large uncertainty regarding the total transmissivity of the polymer film. (2) For irradiation from the high temperature source,  $9.8\% + 4.4\% = 14.4\%$  of the irradiation is in wavelength ranges less than  $2.5 \mu\text{m}$  and greater than  $15 \mu\text{m}$ . Hence, the uncertainty of the total transmissivity of the polymer film is significantly smaller than that associated with the low temperature source. (3) A source temperature exists for which the uncertainty in the total transmissivity is minimum. This temperature is between  $30^\circ\text{C}$  and  $600^\circ\text{C}$ . Why?



### PROBLEM 12.69

**KNOWN:** Thickness, thermal conductivity and surface temperatures of a flat plate. Irradiation on the top surface, reflected irradiation, air and water temperatures, air convection coefficient.

**FIND:** Transmissivity, reflectivity, absorptivity, and emissivity of the plate. Radiosity of the surface. Convection coefficient associated with the water flow.

**SCHEMATIC:**

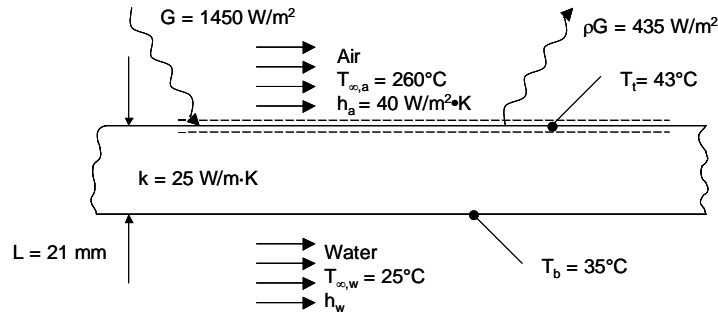

**ASSUMPTIONS:** (1) Opaque and diffuse surface, (2) Water is opaque to thermal radiation.

**ANALYSIS:** The plate is opaque. Therefore,  $\tau = 0$  <

The reflectivity is  $\rho = \rho G / G = (435 \text{ W/m}^2) / (1450 \text{ W/m}^2) = 0.3$  <

The absorptivity is  $\alpha = 1 - \tau - \rho = 1 - 0 - 0.3 = 0.7$  <

Consider an energy balance on the top surface.

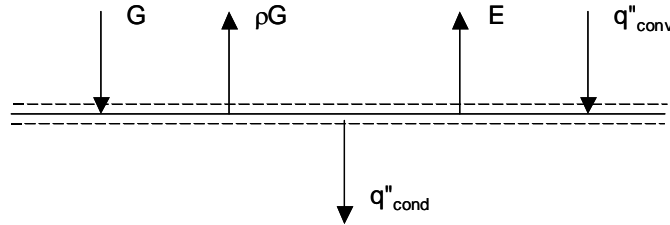

$q''_{\text{cond}} = G + q''_{\text{conv}} - \rho G - E$  where  $E = \epsilon \sigma T_s^4$ . Rearranging, we see that

$$\epsilon = \frac{(G + q''_{\text{conv}} - \rho G - q''_{\text{cond}})}{(\sigma T_t^4)}$$

$$= \frac{\left[ 1450 \text{ W/m}^2 + 40 \text{ W/m}^2 \cdot \text{K} \times (260 - 43)^\circ\text{C} - 435 \text{ W/m}^2 \right] - 25 \text{ W/m} \cdot \text{K} \times (43 - 35)^\circ\text{C} / 0.021 \text{ m}}{5.67 \times 10^{-8} \text{ W/m}^2 \cdot \text{K}^4 \times (273 + 43)^4 \text{ K}^4} = 0.303$$
 <

Since  $\alpha \neq \epsilon$ , the plate is not gray. <

Continued...

### PROBLEM 12.69 (Cont.)

The radiosity associated with the top surface is

$$J = E + \rho G = 0.303 \times 5.67 \times 10^{-8} \text{ W/m}^2 \cdot \text{K}^4 \times (273 + 43)^4 \text{ K}^4 + 435 \text{ W/m}^2 = 606 \text{ W/m}^2 \quad <$$

Consider an energy balance on the bottom surface with  $q''_{\text{cond}} = q''_{\text{conv}}$  which yields

$$\begin{aligned} h_w &= k(T_t - T_b)/[L(T_b - T_{\infty,w})] \\ &= [25 \text{ W/m} \cdot \text{K} \times (43 - 35)^\circ\text{C}]/[0.021\text{m} \times (35 - 25)^\circ\text{C}] = 952 \text{ W/m}^2 \cdot \text{K}. \quad < \end{aligned}$$

**COMMENTS:** (1) The calculated emissivity is extremely sensitive to the plate thickness. Conduction through the plate is much larger than the emission; small changes in the conduction heat flux result in very large changes in the calculated emission. For example, reducing the plate thickness to 20 mm yields a negative emissivity, while increasing the plate thickness to 22 mm yields an emissivity greater than unity. In reality, as the plate thickness is modified, the surface temperatures would also change.

## PROBLEM 12.70

**KNOWN:** Isothermal enclosure at a uniform temperature provides a known irradiation on two small surfaces whose absorption rates have been measured.

**FIND:** (a) Net heat transfer rates and temperatures of the two surfaces, (b) Absorptivity of the surfaces, (c) Emissive power of the surfaces, (d) Emissivity of the surfaces.

**SCHEMATIC:**

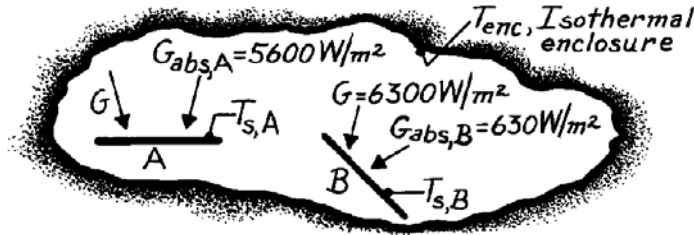

**ASSUMPTIONS:** (1) Enclosure is at a uniform temperature and large compared to surfaces A and B, (2) Surfaces A and B have been in the enclosure a long time, (3) Irradiation to both surfaces is the same.

**ANALYSIS:** (a) Since the surfaces A and B have been within the enclosure a long time, thermal equilibrium conditions exist. That is,

$$q_{A,\text{net}} = q_{B,\text{net}} = 0.$$

Furthermore, the surface temperatures are the same as the enclosure,  $T_{s,A} = T_{s,B} = T_{enc}$ . Since the enclosure is at a uniform temperature, it follows that blackbody radiation exists within the enclosure (see Fig. 12.11) and

$$G = E_b(T_{enc}) = \sigma T_{enc}^4$$

$$T_{enc} = (G/\sigma)^{1/4} = \left(6300 \text{ W/m}^2 / 5.67 \times 10^{-8} \text{ W/m}^2 \cdot \text{K}^4\right)^{1/4} = 577.4 \text{ K.} \quad <$$

(b) From Eq. 12.51, the absorptivity is  $G_{abs}/G$ ,

$$\alpha_A = \frac{5600 \text{ W/m}^2}{6300 \text{ W/m}^2} = 0.89 \quad \alpha_B = \frac{630 \text{ W/m}^2}{6300 \text{ W/m}^2} = 0.10. \quad <$$

(c) Since the surfaces experience zero net heat transfer, the energy balance is  $G_{abs} = E$ . That is, the absorbed irradiation is equal to the emissive power,

$$E_A = 5600 \text{ W/m}^2 \quad E_B = 630 \text{ W/m}^2. \quad <$$

(d) The emissive power,  $E(T)$ , is written as

$$E = \varepsilon E_b(T) = \varepsilon \sigma T^4 \quad \text{or} \quad \varepsilon = E/\sigma T^4.$$

Since the temperature of the surfaces and the emissive powers are known,

$$\varepsilon_A = 5600 \text{ W/m}^2 / \left[5.67 \times 10^{-8} \frac{\text{W}}{\text{m}^2 \cdot \text{K}^4} (577.4 \text{ K})^4\right] = 0.89 \quad \varepsilon_B = 0.10. \quad <$$

**COMMENTS:** Note for this equilibrium condition,  $\varepsilon = \alpha$ .

## PROBLEM 12.71

**KNOWN:** Temperature and spectral characteristics of a diffuse surface at  $T_s = 500$  K situated in a large enclosure with uniform temperature,  $T_{sur} = 1500$  K.

**FIND:** (a) Sketch of spectral distribution of  $E_\lambda$  and  $E_{\lambda,b}$  for the surface, (b) Net heat flux to the surface,  $q''_{rad,in}$  (c) Compute and plot  $q''_{rad,in}$  as a function of  $T_s$  for the range  $500 \leq T_s \leq 1000$  K; also plot the heat flux for a diffuse, gray surface with total emissivities of 0.4 and 0.8; and (d) Compute and plot  $\varepsilon$  and  $\alpha$  as a function of the surface temperature for the range  $500 \leq T_s \leq 1000$  K.

**SCHEMATIC:**

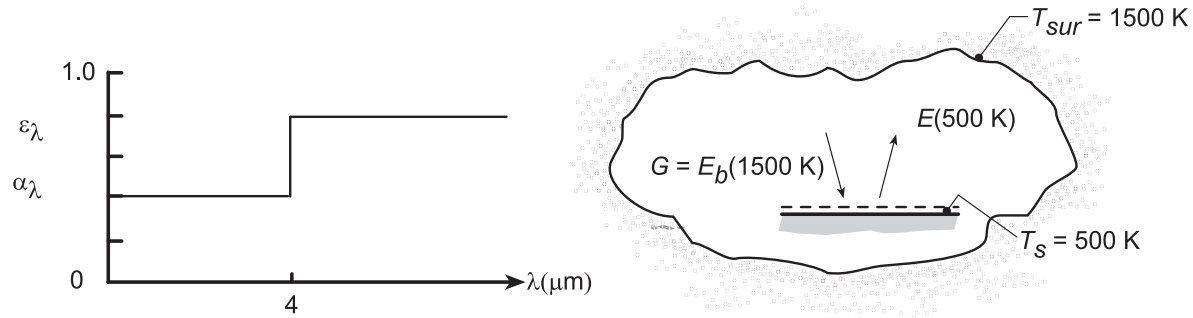

**ASSUMPTIONS:** (1) Surface is diffuse, (2) Convective effects are negligible, (3) Surface irradiation corresponds to blackbody emission at 1500 K.

**ANALYSIS:** (a) From Wien's displacement law, Eq. 12.31,  $\lambda_{max} T = 2898 \mu\text{m}\cdot\text{K}$ . Hence, for blackbody emission from the surface at  $T_s = 500$  K,

$$\lambda_{max} = \frac{2898 \mu\text{m} \cdot \text{K}}{500 \text{ K}} = 5.80 \mu\text{m}.$$

(b) From an energy balance on the surface, the net heat flux to the surface is

$$q''_{rad,in} = \alpha G - E = \alpha E_b(1500 \text{ K}) - \varepsilon E_b(500 \text{ K}).$$

From Eq. 12.52,

$$\alpha = 0.4 \int_0^4 \frac{E_{\lambda,b}(1500)}{E_b} d\lambda + 0.8 \int_4^\infty \frac{E_{\lambda,b}(1500)}{E_b} d\lambda = 0.4 F_{(0-4\mu\text{m})} + 0.8 [1 - F_{(0-4\mu\text{m})}].$$

From Table 12.1 with  $\lambda T = 4 \mu\text{m} \times 1500 \text{ K} = 6000 \mu\text{m}\cdot\text{K}$ ,  $F_{(0-4)} = 0.738$ , find

$$\alpha = 0.4 \times 0.738 + 0.8 (1 - 0.738) = 0.505.$$

From Eq. 12.43

$$\varepsilon = 0.4 \int_0^4 \frac{E_{\lambda,b}(500)}{E_b} d\lambda + 0.8 \int_4^\infty \frac{E_{\lambda,b}(500)}{E_b} d\lambda = 0.4 F_{(0-4\mu\text{m})} + 0.8 [1 - F_{(0-4\mu\text{m})}].$$

From Table 12.1 with  $\lambda T = 4 \mu\text{m} \times 500 \text{ K} = 2000 \mu\text{m}\cdot\text{K}$ ,  $F_{(0-4)} = 0.0667$ , find

$$\varepsilon = 0.4 \times 0.0667 + 0.8 (1 - 0.0667) = 0.773.$$

Hence, the net heat flux to the surface is

$$q''_{rad,in} = 5.67 \times 10^{-8} \text{ W/m}^2 \cdot \text{K}^4 [0.505 \times (1500 \text{ K})^4 - 0.773 \times (500 \text{ K})^4] = 1.422 \times 10^5 \text{ W/m}^2. \quad \leftarrow$$

Continued...

### PROBLEM 12.71 (Cont.)

(c) Using the foregoing equations in the IHT workspace along with the *IHT Radiation Tool, Band Emission Factor*,  $q''_{\text{rad,in}}$  was computed and plotted as a function of  $T_s$ .

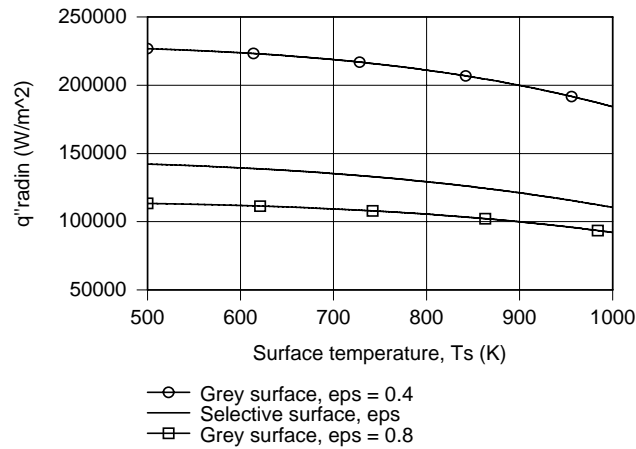

The net radiation heat rate,  $q''_{\text{rad,in}}$  decreases with increasing surface temperature since  $E$  increases with  $T_s$  and the absorbed irradiation remains constant according to Eq. (1). The heat flux is largest for the gray surface with  $\epsilon = 0.4$  and the smallest for the gray surface with  $\epsilon = 0.8$ . As expected, the heat flux for the selective surface is between the limits of the two gray surfaces.

(d) Using the IHT model of part (c), the emissivity and absorptivity of the surface are computed and plotted below.

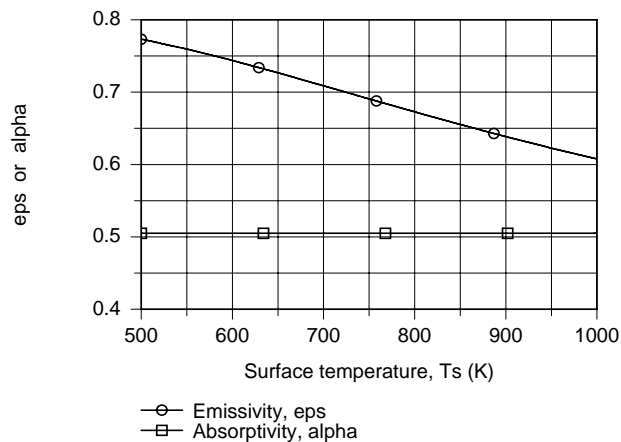

The absorptivity,  $\alpha = \alpha(\alpha_\lambda, T_{\text{sur}})$ , remains constant as  $T_s$  changes since it is a function of  $\alpha_\lambda$  (or  $\epsilon_\lambda$ ) and  $T_{\text{sur}}$  only. The emissivity,  $\epsilon = \epsilon(\epsilon_\lambda, T_s)$  is a function of  $T_s$  and decreases as  $T_s$  increases. Could you have surmised as much by looking at the spectral emissivity distribution? Under what condition would you expect  $\alpha = \epsilon$ ?

## PROBLEM 12.72

**KNOWN:** Opaque, diffuse surface with prescribed spectral reflectivity and at a temperature of 750K is subjected to a prescribed spectral irradiation,  $G_\lambda$ .

**FIND:** (a) Total absorptivity,  $\alpha$ , (b) Total emissivity,  $\varepsilon$ , (c) Net radiative heat flux to the surface.

**SCHEMATIC:**

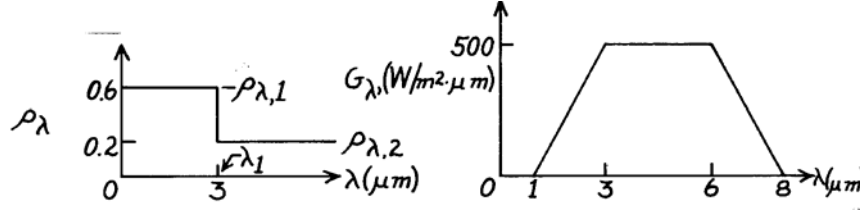

**ASSUMPTIONS:** (1) Opaque and diffuse surface, (2) Backside insulated.

**ANALYSIS:** (a) The total absorptivity is determined from Eq. 12.52 and 12.62,

$$\alpha_\lambda = 1 - \rho_\lambda \quad \text{and} \quad \alpha = \int_0^\infty \alpha_\lambda G_\lambda d\lambda / G. \quad (1,2)$$

Evaluating by separate integrals over various wavelength intervals.

$$\alpha = \frac{(1 - \rho_{\lambda,1}) \int_1^3 G_\lambda d\lambda + (1 - \rho_{\lambda,2}) \int_3^6 G_\lambda d\lambda + (1 - \rho_{\lambda,2}) \int_6^8 G_\lambda d\lambda}{\int_1^3 G_\lambda d\lambda + \int_3^6 G_\lambda d\lambda + \int_6^8 G_\lambda d\lambda} = \frac{G_{\text{abs}}}{G}$$

$$G_{\text{abs}} = (1 - 0.6) \left[ 0.5 \times 500 \text{ W/m}^2 \cdot \mu\text{m} (3 - 1) \mu\text{m} \right] + (1 - 0.2) \left[ 500 \text{ W/m}^2 \cdot \mu\text{m} (6 - 3) \mu\text{m} \right] \\ + (1 - 0.2) \left[ 0.5 \times 500 \text{ W/m}^2 \cdot \mu\text{m} (8 - 6) \mu\text{m} \right]$$

$$G = 0.5 \times 500 \text{ W/m}^2 \cdot \mu\text{m} \times (3 - 1) \mu\text{m} + 500 \text{ W/m}^2 \cdot \mu\text{m} (6 - 3) \mu\text{m} + 0.5 \times 500 \text{ W/m}^2 \cdot \mu\text{m} (8 - 6) \mu\text{m}$$

$$\alpha = \frac{[200 + 1200 + 400] \text{ W/m}^2}{[500 + 1500 + 500] \text{ W/m}^2} = \frac{1800 \text{ W/m}^2}{2500 \text{ W/m}^2} = 0.720. \quad <$$

(b) The total emissivity of the surface is determined from Eq. 12.43 and 12.62,

$$\varepsilon_\lambda = \alpha_\lambda \quad \text{and, hence} \quad \varepsilon_\lambda = 1 - \rho_\lambda. \quad (3,4)$$

The total emissivity can then be expressed as

$$\varepsilon = \int_0^\infty \varepsilon_\lambda E_{\lambda,b}(\lambda, T_s) d\lambda / E_b(T_s) = \int_0^\infty (1 - \rho_\lambda) E_{\lambda,b}(\lambda, T_s) d\lambda / E_b(T_s)$$

$$\varepsilon = (1 - \rho_{\lambda,1}) \int_0^3 E_{\lambda,b}(\lambda, T_s) d\lambda / E_b(T_s) + (1 - \rho_{\lambda,2}) \int_3^\infty E_{\lambda,b}(\lambda, T_s) d\lambda / E_b(T_s)$$

$$\varepsilon = (1 - \rho_{\lambda,1}) F_{(0 \rightarrow 3 \mu\text{m})} + (1 - \rho_{\lambda,2}) [1 - F_{(0 \rightarrow 3 \mu\text{m})}]$$

$$\varepsilon = (1 - 0.6) \times 0.111 + (1 - 0.2) [1 - 0.111] = 0.756 \quad <$$

where Table 12.1 is used to find  $F_{(0 \rightarrow \lambda)} = 0.111$  for  $\lambda_1 T_s = 3 \times 750 = 2250 \mu\text{m} \cdot \text{K}$ .

(c) The net radiative heat flux to the surface is

$$q''_{\text{rad}} = \alpha G - \varepsilon E_b(T_s) = \alpha G - \varepsilon \sigma T_s^4$$

$$q''_{\text{rad}} = 0.720 \times 2500 \text{ W/m}^2$$

$$-0.756 \times 5.67 \times 10^{-8} \text{ W/m}^2 \cdot \text{K}^4 (750\text{K})^4 = -11,763 \text{ W/m}^2. \quad <$$

### PROBLEM 12.73

**KNOWN:** Diffuse glass at  $T_g = 750$  K with prescribed spectral radiative properties being heated in a large oven having walls with emissivity of 0.75 and 1800 K.

**FIND:** (a) Total transmissivity  $\tau$ , total reflectivity  $\rho$ , and total emissivity  $\varepsilon$  of the glass; Net radiative heat flux to the glass, (b)  $q''_{\text{rad, in}}$ ; and (c) Compute and plot  $q''_{\text{rad, in}}$  as a function of glass temperatures for the range  $500 \leq T_g \leq 800$  K for oven wall temperatures of  $T_w = 1500, 1800$  and  $2000$  K.

**SCHEMATIC:**

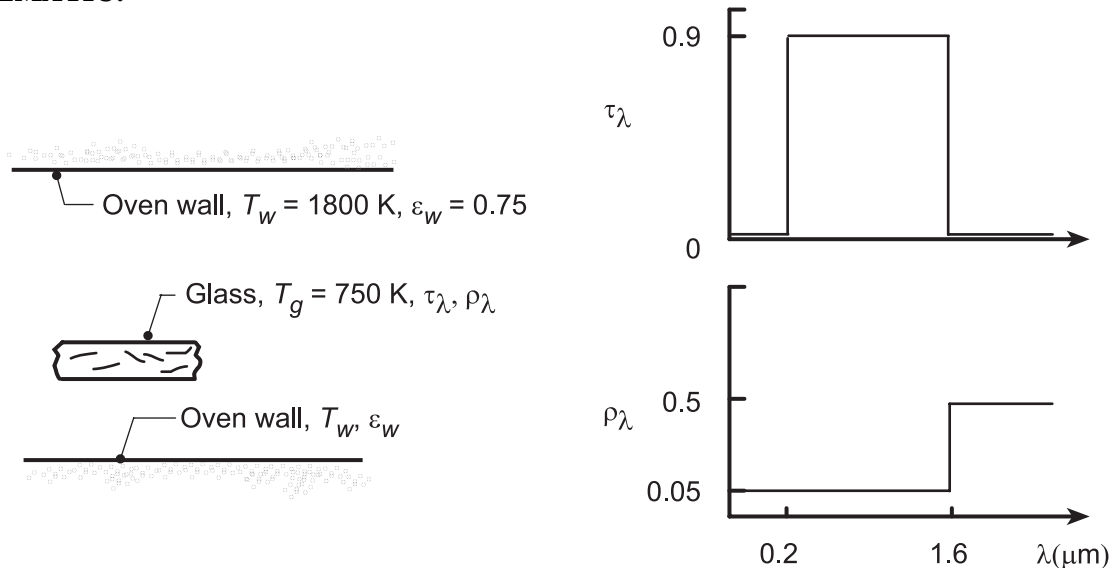

**ASSUMPTIONS:** (1) Glass is of uniform temperature, (2) Glass is diffuse, (3) Furnace walls large compared to the glass;  $\varepsilon_w$  plays no role, (4) Negligible convection.

**ANALYSIS:** (a) From knowledge of the spectral transmittance,  $\tau_\lambda$ , and spectral reflectivity,  $\rho_\lambda$ , the following radiation properties are evaluated:

*Total transmissivity,  $\tau$ :* For the irradiation from the furnace walls,  $G_\lambda = E_{\lambda, b}(\lambda, T_w)$ . Hence

$$\tau = \int_0^\infty \tau_\lambda E_{\lambda, b}(\lambda, T_w) d\lambda / \sigma T_w^4 \approx \tau_{\lambda 1} F_{(0-\lambda T)} = 0.9 \times 0.25 = 0.225. \quad \leftarrow$$

where  $\lambda T = 1.6 \mu\text{m} \times 1800 \text{ K} = 2880 \mu\text{m} \cdot \text{K} \approx 2898 \mu\text{m} \cdot \text{K}$  giving  $F_{(0-\lambda T)} \approx 0.25$ .

*Total reflectivity,  $\rho$ :* With  $G_\lambda = E_{\lambda, b}(\lambda, T_w)$ ,  $T_w = 1800$  K, and  $F_{0-\lambda T} = 0.25$ ,

$$\rho \approx \rho_{\lambda 1} F_{(0-\lambda T)} + \rho_{\lambda 2} (1 - F_{(0-\lambda T)}) = 0.05 \times 0.25 + 0.5(1 - 0.25) = 0.388 \quad \leftarrow$$

*Total absorptivity,  $\alpha$ :* To perform the energy balance later, we'll need  $\alpha$ . Employ the conservation expression,

$$\alpha = 1 - \rho - \tau = 1 - 0.388 - 0.225 = 0.387.$$

*Emissivity,  $\varepsilon$ :* Based upon surface temperature  $T_g = 750$  K, for

$$\lambda T = 1.6 \mu\text{m} \times 750 \text{ K} = 1200 \mu\text{m} \cdot \text{K}, \quad F_{0-\lambda T} \approx 0.002.$$

Hence for  $\lambda > 1.6 \mu\text{m}$ ,  $\varepsilon \approx \varepsilon_\lambda \approx 0.5. \quad \leftarrow$

(b) Performing an energy balance on the glass, the net radiative heat flux by radiation into the glass is,

Continued...

### PROBLEM 12.73 (Cont.)

$$q''_{\text{net,in}} = E''_{\text{in}} - E''_{\text{out}}$$

$$q''_{\text{net,in}} = 2(\alpha G - \varepsilon E_b(T_g))$$

where  $G = \sigma T_w^4$

$$q''_{\text{net,in}} = 2\left[0.387\sigma(1800\text{K})^4 - 0.5\sigma(750\text{K})^4\right]$$

$$q''_{\text{net,in}} = 442.8 \text{ kW/m}^2.$$

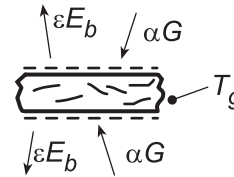

(b) Using the foregoing equations in the IHT Workspace along with the *IHT Radiation Tool, Band Emission Factor*, the net radiative heat flux,  $q''_{\text{rad,in}}$ , was computed and plotted as a function of  $T_g$  for selected wall temperatures  $T_w$ .

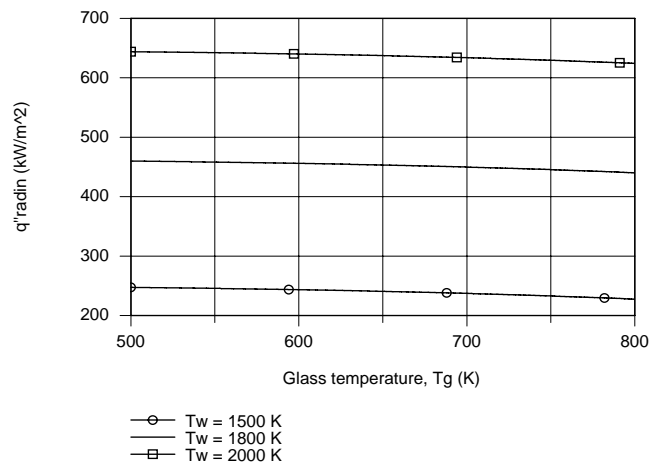

As the glass temperature increases, the rate of emission increases so we'd expect the net radiative heat rate into the glass to decrease. Note that the decrease is not very significant. The effect of increased wall temperature is to increase the irradiation and, hence the absorbed irradiation to the surface and the net radiative flux increase.



## PROBLEM 12.74

**KNOWN:** Material with prescribed radiative properties covering the peep hole of a furnace and exposed to surroundings on the outer surface.

**FIND:** Steady-state temperature of the cover,  $T_s$ ; heat loss from furnace.

**SCHEMATIC:**

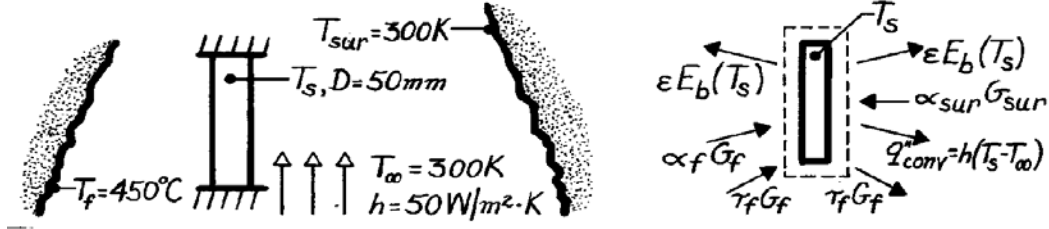

**ASSUMPTIONS:** (1) Cover is isothermal, no gradient, (2) Surroundings of the outer surface are large compared to cover, (3) Cover is insulated from its mount on furnace wall, (4) Negligible convection on interior surface.

**PROPERTIES:** Cover material (given): For irradiation from the furnace interior:  $\tau_f = 0.8$ ,  $\rho_f = 0$ ; For room temperature emission:  $\tau = 0$ ,  $\varepsilon = 0.8$ .

**ANALYSIS:** Perform an energy balance identifying the modes of heat transfer,

$$\dot{E}_{\text{in}} - \dot{E}_{\text{out}} = 0 \quad \alpha_f G_f + \alpha_{\text{sur}} G_{\text{sur}} - 2\varepsilon E_b(T_s) - h(T_s - T_{\infty}) = 0. \quad (1)$$

Recognize that  $G_f = \sigma T_f^4$   $G_{\text{sur}} = \sigma T_{\text{sur}}^4$  (2,3)

From Eq. 12.63, it follows that  $\alpha_f = 1 - \tau_f - \rho_f = 1 - 0.8 - 0.0 = 0.2$ . (4)

Since the irradiation  $G_{\text{sur}}$  will have nearly the same spectral distribution as the emissive power of the cover,  $E_b(T_s)$ , and since  $G_{\text{sur}}$  is diffuse irradiation,

$$\alpha_{\text{sur}} = \varepsilon = 0.8. \quad (5)$$

This reasoning follows from Eqs. 12.69 and 12.70. Substituting Eqs. (2-5) into Eq. (1) and using numerical values,

$$\begin{aligned} 0.2 \times 5.67 \times 10^{-8} (450 + 273)^4 \text{ W/m}^2 + 0.8 \times 5.67 \times 10^{-8} \times 300^4 \text{ W/m}^2 & \quad (2-5) \\ - 2 \times 0.8 \times 5.67 \times 10^{-8} T_s^4 \text{ W/m}^2 - 50 \text{ W/m}^2 \cdot \text{K} (T_s - 300) \text{ K} = 0 & \quad < \\ 9.072 \times 10^{-8} T_s^4 + 50 T_s = 18,466 & \quad \text{or} \quad T_s = 344 \text{ K}. \end{aligned}$$

The heat loss from the furnace (see energy balance schematic) is

$$\begin{aligned} q_{f, \text{loss}} &= A_s \left[ \alpha_f G_f + \tau_f G_f - \varepsilon E_b(T_s) \right] = \frac{\pi D^2}{4} \left[ (\alpha_f + \tau_f) G_f - \varepsilon E_b(T_s) \right] \\ q_{f, \text{loss}} &= \pi (0.050 \text{ m})^2 / 4 \left[ (0.8 + 0.2) (723 \text{ K})^4 \right. \\ & \quad \left. - 0.8 (344 \text{ K})^4 \right] 5.67 \times 10^{-8} \text{ W/m}^2 \cdot \text{K}^4 = 29.2 \text{ W}. \end{aligned} \quad <$$

## PROBLEM 12.75

**KNOWN:** Window with prescribed  $\tau_\lambda$  and  $\rho_\lambda$  mounted on cooled vacuum chamber passing radiation from a solar simulator.

**FIND:** (a) Solar transmissivity of the window material, (b) State-state temperature reached by window with simulator operating, (c) Net radiation heat transfer to chamber.

**SCHEMATIC:**

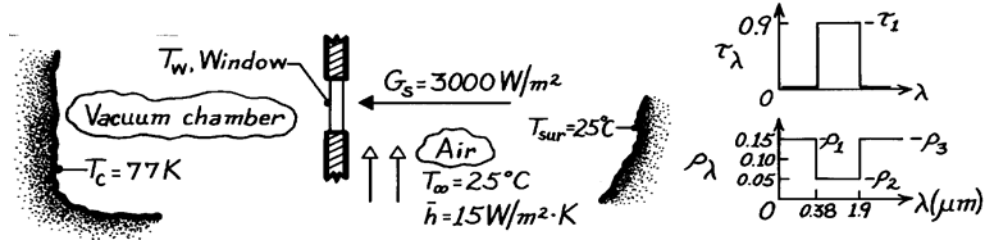

**ASSUMPTIONS:** (1) Steady-state conditions, (2) Diffuse behavior of window material, (3) Chamber and room surroundings large compared to window, (4) Solar simulator flux has spectral distribution of 5800K blackbody, (5) Window insulated from its mount, (6) Window is isothermal at  $T_w$ .

**ANALYSIS:** (a) Using Eq. 12.61 and recognizing that  $G_{\lambda,S} \sim E_{b,\lambda}(\lambda, 5800\text{K})$ ,

$$\tau_S = \tau_1 \int_{0.38}^{1.9} E_{\lambda,b}(\lambda, 5800\text{K}) d\lambda / E_b(5800\text{K}) = \tau_1 \left[ F_{(0 \rightarrow 1.9\mu\text{m})} - F_{(0 \rightarrow 0.38\mu\text{m})} \right].$$

From Table 12.1 at  $\lambda T = 1.9 \times 5800 = 11,020 \mu\text{m}\cdot\text{K}$ ,  $F_{(0 \rightarrow \lambda)} = 0.932$ ; at  $\lambda T = 0.38 \times 5800 \mu\text{m}\cdot\text{K} = 2,204 \mu\text{m}\cdot\text{K}$ ,  $F_{(0 \rightarrow \lambda)} = 0.101$ ; hence

$$\tau_S = 0.90 [0.932 - 0.101] = 0.748. \quad <$$

Recognizing that later we'll need  $\alpha_S$ , use Eq. 12.58 to find  $\rho_S$

$$\rho_S = \rho_1 F_{(0 \rightarrow 0.38\mu\text{m})} + \rho_2 \left[ F_{(0 \rightarrow 1.9\mu\text{m})} - F_{(0 \rightarrow 0.38\mu\text{m})} \right] + \rho_3 \left[ 1 - F_{(0 \rightarrow 1.9\mu\text{m})} \right]$$

$$\rho_S = 0.15 \times 0.101 + 0.05 [0.932 - 0.101] + 0.15 [1 - 0.932] = 0.067$$

$$\alpha_S = 1 - \rho_S - \tau_S = 1 - 0.067 - 0.748 = 0.185.$$

(b) Perform an energy balance on the window.

$$\alpha_S G_S - q''_{w-c} - q''_{w-sur} - q''_{conv} = 0$$

$$\alpha_S G_S - \varepsilon \sigma (T_w^4 - T_c^4) - \varepsilon \sigma (T_w^4 - T_{sur}^4) - \bar{h} (T_w - T_\infty) = 0.$$

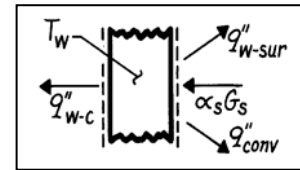

Recognize that  $\rho_\lambda(\lambda > 1.9) = 0.15$  and that  $\varepsilon \approx 1 - 0.15 = 0.85$  since  $T_w$  will be near 300K.

Substituting numerical values, find by trial and error,

$$0.185 \times 3000 \text{ W/m}^2 - 0.85 \times \sigma \left[ 2T_w^4 - 298^4 - 77^4 \right] \text{ K}^4 - 28 \text{ W/m}^2 \cdot \text{K} (T_w - 298) \text{ K} = 0$$

$$T_w = 302.6\text{K} = 29.6^\circ\text{C}. \quad <$$

(c) The net radiation transfer per unit area of the window to the vacuum chamber, excluding the transmitted simulated solar flux is

$$q''_{w-c} = \varepsilon \sigma (T_w^4 - T_c^4) = 0.85 \times 5.67 \times 10^{-8} \text{ W/m}^2 \cdot \text{K}^4 \left[ 302.6^4 - 77^4 \right] \text{ K}^4 = 402 \text{ W/m}^2. \quad <$$

## PROBLEM 12.76

**KNOWN:** Reading and emissivity of a thermocouple (TC) located in a large duct to measure gas stream temperature. Duct wall temperature and emissivity; convection coefficient.

**FIND:** (a) Gas temperature,  $T_\infty$ , (b) Effect of convection coefficient on measurement error.

**SCHEMATIC:**

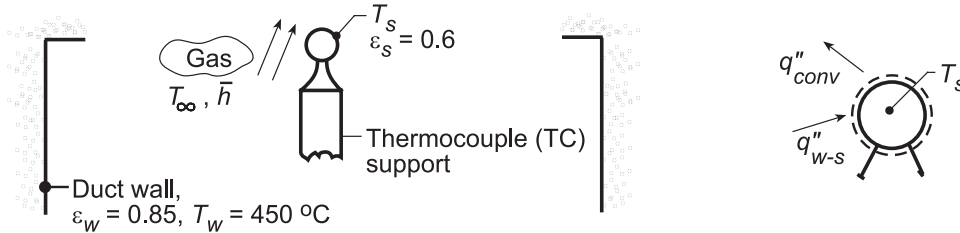

**ASSUMPTIONS:** (1) Steady-state conditions, (2) Negligible heat loss from TC sensing junction to support, (3) Duct wall much larger than TC, (4) TC surface is diffuse-gray.

**ANALYSIS:** (a) Performing an energy balance on the thermocouple, it follows that

$$q''_{w-s} - q''_{conv} = 0.$$

Hence,

$$\epsilon_s \sigma (T_w^4 - T_s^4) - \bar{h} (T_s - T_\infty) = 0.$$

Solving for  $T_\infty$  with  $T_s = 180^\circ\text{C}$ ,

$$T_\infty = T_s - \frac{\epsilon_s \sigma}{\bar{h}} (T_w^4 - T_s^4)$$

$$T_\infty = (180 + 273)\text{K} - \frac{0.6(5.67 \times 10^{-8} \text{ W/m}^2 \cdot \text{K}^4)}{125 \text{ W/m}^2 \cdot \text{K}} \left( [450 + 273]^4 - [180 + 273]^4 \right) \text{K}^4$$

$$T_\infty = 453 \text{ K} - 62.9 \text{ K} = 390 \text{ K} = 117^\circ\text{C}.$$

<

(b) Using the IHT *First Law* model for an *Isothermal Solid Sphere* to solve the foregoing energy balance for  $T_s$ , with  $T_\infty = 125^\circ\text{C}$ , the measurement error, defined as  $\Delta T = T_s - T_\infty$ , was determined and is plotted as a function of  $\bar{h}$ .

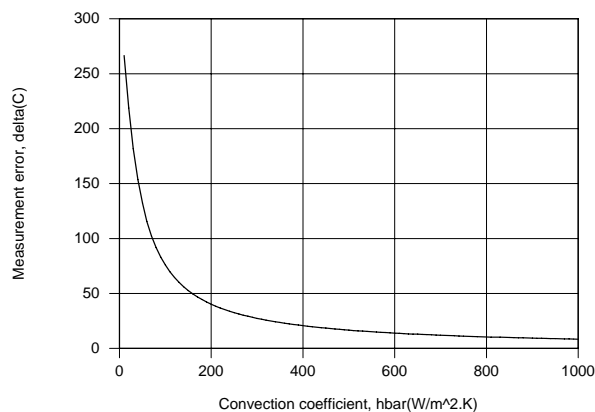

The measurement error is enormous ( $\Delta T \approx 270^\circ\text{C}$ ) for  $\bar{h} = 10 \text{ W/m}^2 \cdot \text{K}$ , but decreases with increasing  $\bar{h}$ . However, even for  $\bar{h} = 1000 \text{ W/m}^2 \cdot \text{K}$ , the error ( $\Delta T \approx 8^\circ\text{C}$ ) is not negligible. Such errors must always be considered when measuring a gas temperature in surroundings whose temperature differs significantly from that of the gas.

Continued...

### **PROBLEM 12.76 (Cont.)**

**COMMENTS:** (1) Because the duct wall surface area is much larger than that of the thermocouple, its emissivity is not a factor. (2) For such a situation, a shield about the thermocouple would reduce the influence of the hot duct wall on the indicated TC temperature. A low emissivity thermocouple coating would also help.

## PROBLEM 12.77

**KNOWN:** Diameter and emissivity of a horizontal thermocouple (TC) sheath located in a large room. Air and wall temperatures.

**FIND:** (a) Temperature indicated by the TC, (b) Effect of emissivity on measurement error.

**SCHEMATIC:**

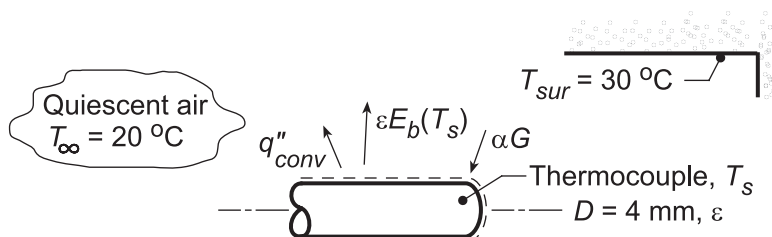

**ASSUMPTIONS:** (1) Room walls approximate isothermal, large surroundings, (2) Room air is quiescent, (3) TC approximates horizontal cylinder, (4) No conduction losses, (5) TC surface is opaque, diffuse and gray.

**PROPERTIES:** Table A-4, Air (assume  $T_s = 25 \text{ }^\circ\text{C}$ ,  $T_f = (T_s + T_\infty)/2 \approx 296 \text{ K}$ , 1 atm):

$$\nu = 15.53 \times 10^{-6} \text{ m}^2/\text{s}, \quad k = 0.026 \text{ W/m}\cdot\text{K}, \quad \alpha = 22.0 \times 10^{-6} \text{ m}^2/\text{s}, \quad \text{Pr} = 0.708, \quad \beta = 1/T_f.$$

**ANALYSIS:** (a) Perform an energy balance on the thermocouple considering convection and radiation processes. On a unit area basis, with  $q''_{conv} = \bar{h}(T_s - T_\infty)$ ,

$$\begin{aligned} \dot{E}_{in} - \dot{E}_{out} &= 0 \\ \alpha G - \epsilon E_b(T_s) - \bar{h}(T_s - T_\infty) &= 0. \end{aligned} \quad (1)$$

Since the surroundings are isothermal and large compared to the thermocouple,  $G = E_b(T_{sur})$ . For the gray-diffuse surface,  $\alpha = \epsilon$ . Using the Stefan-Boltzmann law,  $E_b = \sigma T^4$ , Eq. (1) becomes

$$\epsilon \sigma (T_{sur}^4 - T_s^4) - \bar{h}(T_s - T_\infty) = 0. \quad (2)$$

Using the Churchill-Chu correlation for a horizontal cylinder, estimate  $\bar{h}$  due to free convection.

$$\overline{\text{Nu}}_D = \frac{\bar{h}D}{k} = \left\{ 0.60 + \frac{0.387 \text{Ra}_D^{1/6}}{\left[ 1 + (0.559/\text{Pr})^{9/16} \right]^{8/27}} \right\}^2, \quad \text{Ra}_D = \frac{g\beta\Delta T D^3}{\nu\alpha}. \quad (3,4)$$

To evaluate  $\text{Ra}_D$  and  $\overline{\text{Nu}}_D$ , assume  $T_s = 25 \text{ }^\circ\text{C}$ , giving

$$\text{Ra}_D = \frac{9.8 \text{ m/s}^2 (1/296 \text{ K})(25 - 20) \text{ K} (0.004 \text{ m})^3}{15.53 \times 10^{-6} \text{ m}^2/\text{s} \times 22.0 \times 10^{-6} \text{ m}^2/\text{s}} = 31.0$$

$$\bar{h} = \frac{0.026 \text{ W/m}\cdot\text{K}}{0.004 \text{ m}} \left\{ 0.60 + \frac{0.387(31.0)^{1/6}}{\left[ 1 + (0.559/0.708)^{9/16} \right]^{8/27}} \right\} = 8.89 \text{ W/m}^2\cdot\text{K}. \quad (5)$$

With  $\epsilon = 0.4$ , the energy balance, Eq. (2), becomes

$$0.4 \times 5.67 \times 10^{-8} \text{ W/m}^2\cdot\text{K}^4 [(30 + 273)^4 - T_s^4] \text{ K}^4 - 8.89 \text{ W/m}^2\cdot\text{K} [T_s - (20 + 273)] \text{ K} = 0 \quad (6)$$

where all temperatures are in kelvin units. By trial-and-error, find

$$T_s \approx 22.2 \text{ }^\circ\text{C}$$

<  
Continued...

### PROBLEM 12.77 (Cont.)

(b) The thermocouple measurement error is defined as  $\Delta T = T_s - T_\infty$  and is a consequence of radiation exchange with the surroundings. Using the IHT *First Law Model* for an *Isothermal Solid Cylinder* with the appropriate *Correlations* and *Properties* Toolpads to solve the foregoing energy balance for  $T_s$ , the measurement error was determined as a function of the emissivity.

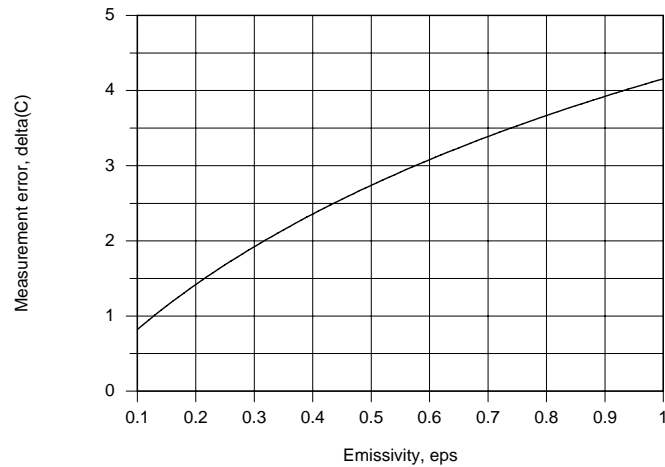

The measurement error decreases with decreasing  $\epsilon$ , and hence a reduction in net radiation transfer from the surroundings. However, even for  $\epsilon = 0.1$ , the error ( $\Delta T \approx 1^\circ\text{C}$ ) is not negligible.

**COMMENT:** A trial-and-error solution accounting for the effect of temperature-dependent properties and various values of  $\bar{h}$  yields  $T_s = 22.1^\circ\text{C}$  ( $\bar{h} = 7.85 \text{ W/m}^2\cdot\text{K}$ ).

## PROBLEM 12.78

**KNOWN:** Temperature sensor imbedded in a diffuse, gray tube of emissivity 0.8 positioned within a room with walls and ambient air at 30 and 20 °C, respectively. Convection coefficient is 5 W/m<sup>2</sup>·K.

**FIND:** (a) Temperature of sensor for prescribed conditions, (b) Effect of surface emissivity and using a fan to induce air flow over the tube.

**SCHEMATIC:**

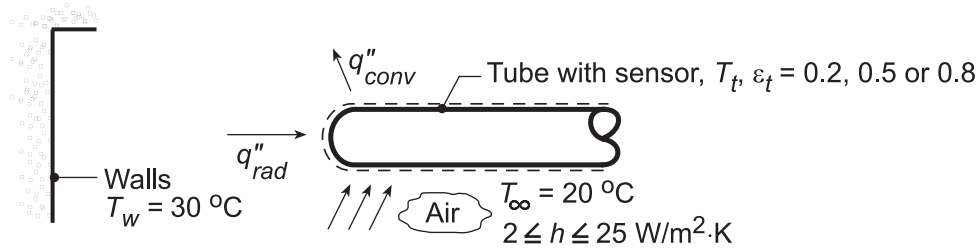

**ASSUMPTIONS:** (1) Room walls (surroundings) much larger than tube, (2) Tube is diffuse, gray surface, (3) No losses from tube by conduction, (4) Steady-state conditions, (5) Sensor measures temperature of tube surface.

**ANALYSIS:** (a) Performing an energy balance on the tube,  $\dot{E}_{in} - \dot{E}_{out} = 0$ . Hence,  $q''_{rad} - q''_{conv} = 0$ , or  $\epsilon_t \sigma (T_w^4 - T_t^4) - h(T_t - T_\infty) = 0$ . With  $h = 5 \text{ W/m}^2 \cdot \text{K}$  and  $\epsilon_t = 0.8$ , the energy balance becomes

$$0.8 \times 5.67 \times 10^{-8} \text{ W/m}^2 \cdot \text{K}^4 \left[ (30 + 273)^4 - T_t^4 \right] \text{K}^4 = 5 \text{ W/m}^2 \cdot \text{K} [T_t - (20 + 273)] \text{K}$$

$$4.5360 \times 10^{-8} \left[ 303^4 - T_t^4 \right] = 5 [T_t - 293]$$

which yields  $T_t = 298 \text{ K} = 25^\circ\text{C}$ .

(b) Using the IHT *First Law Model*, the following results were determined.

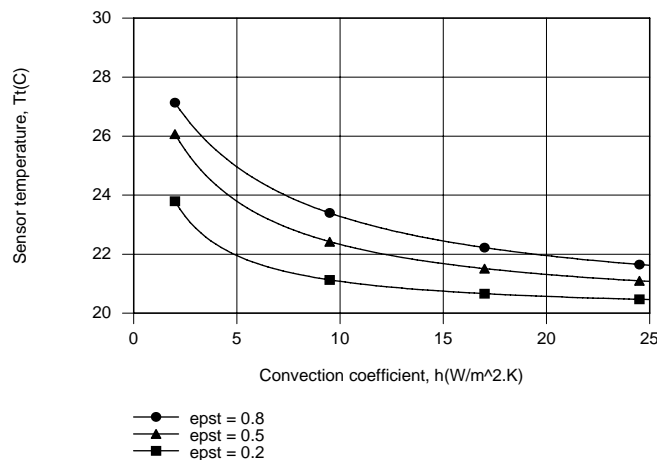

The sensor temperature exceeds the air temperature due to radiation absorption, which must be balanced by convection heat transfer. Hence, the excess temperature  $T_t - T_\infty$ , may be reduced by increasing  $h$  or by decreasing  $\alpha_t$ , which equals  $\epsilon_t$  for a diffuse-gray surface, and hence the absorbed radiation.

**COMMENTS:** A fan will increase the air velocity over the sensor and thereby increase the convection heat transfer coefficient. Hence, the sensor will indicate a temperature closer to  $T_\infty$ .

## PROBLEM 12.79

**KNOWN:** Diffuse-gray sphere is placed in large oven with known wall temperature and experiences convection process.

**FIND:** (a) Net heat transfer rate to the sphere when its temperature is 300 K, (b) Steady-state temperature of the sphere, (c) Time required for the sphere, initially at 300 K, to come within 20 K of the steady-state temperature, and (d) Elapsed time of part (c) as a function of the convection coefficient for  $10 \leq h \leq 25$   $\text{W}/\text{m}^2\cdot\text{K}$  for emissivities 0.2, 0.4 and 0.8.

**SCHEMATIC:**

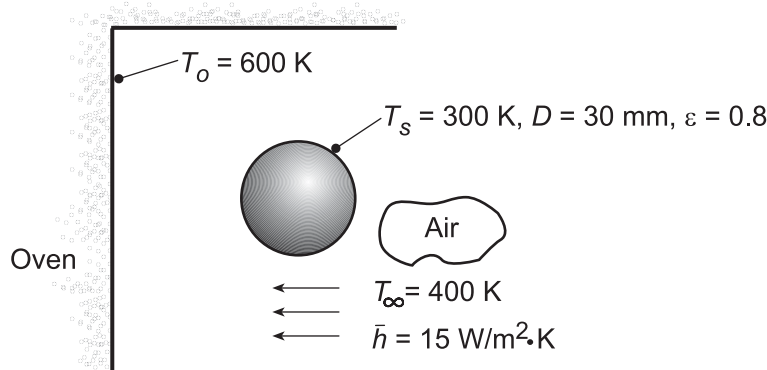

**ASSUMPTIONS:** (1) Sphere surface is diffuse-gray, (2) Sphere area is much smaller than the oven wall area, (3) Sphere surface is isothermal.

**PROPERTIES:** Sphere (Given) :  $\alpha = 7.25 \times 10^{-5} \text{ m}^2/\text{s}$ ,  $k = 185 \text{ W}/\text{m}\cdot\text{K}$ .

**ANALYSIS:** (a) From an energy balance on the sphere find

$$q_{\text{net}} = q_{\text{in}} - q_{\text{out}}$$

$$q_{\text{net}} = \alpha G A_s + q_{\text{conv}} - E A_s$$

$$q_{\text{net}} = \alpha \sigma T_o^4 A_s + h A_s (T_\infty - T_s) - \epsilon \sigma T_s^4 A_s \quad (1)$$

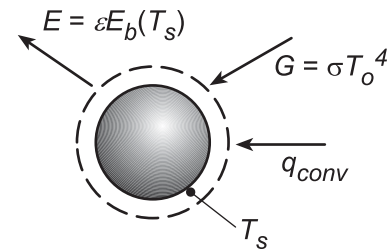

Note that the irradiation to the sphere is the emissive power of a blackbody at the temperature of the oven walls. This follows since the oven walls are isothermal and have a much larger area than the sphere area. Substituting numerical values, noting that  $\alpha = \epsilon$  since the surface is diffuse-gray and that  $A_s = \pi D^2$ , find

$$q_{\text{net}} = \left[ 0.8 \times 5.67 \times 10^{-8} \text{ W}/\text{m}^2 \cdot \text{K}^4 (600\text{K})^4 + 15 \text{ W}/\text{m}^2 \cdot \text{K} \times (400 - 300) \text{ K} - 0.8 \times 5.67 \times 10^{-8} \text{ W}/\text{m}^2 \cdot \text{K}^4 (300\text{K})^4 \right] \pi (30 \times 10^{-3} \text{ m})^2$$

$$q_{\text{net}} = [16.6 + 4.2 - 1.0] \text{ W} = 19.8 \text{ W} \quad (1) <$$

(b) For steady-state conditions,  $q_{\text{net}}$  in the energy balance of Eq. (1) will be zero,

$$0 = \alpha \sigma T_o^4 A_s + h A_s (T_\infty - T_{\text{ss}}) - \epsilon \sigma T_{\text{ss}}^4 A_s \quad (2)$$

Substitute numerical values and find the steady-state temperature as

$$T_{\text{ss}} = 538.2\text{K} \quad <$$

Continued...



### PROBLEM 12.79 (Cont.)

(c) Using the *IHT Lumped Capacitance Model* considering convection and radiation processes, the temperature- time history of the sphere, initially at  $T_s(0) = T_i = 300$  K, can be determined. The elapsed time required to reach

$$T_s(t_0) = (538.2 - 20) \text{ K} = 518.2 \text{ K}$$

was found as

$$t_0 = 855 \text{ s} = 14.3 \text{ min}$$

<

(d) Using the IHT model of part (c), the elapsed time for the sphere to reach within 20 K of its steady-state temperature,  $t_f$ , as a function of the convection coefficient for selected emissivities is plotted below.

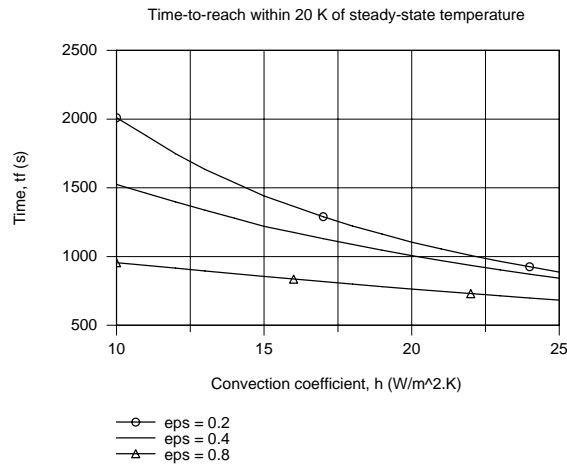

For a fixed convection coefficient,  $t_f$  increases with decreasing  $\epsilon$  since the radiant heat transfer into the sphere decreases with decreasing emissivity. For a given emissivity, the  $t_f$  decreases with increasing  $h$  since the convection heat rate increases with increasing  $h$ . However, the effect is much more significant with lower values of emissivity.

**COMMENTS:** (1) Why is  $t_f$  more strongly dependent on  $h$  for a lower sphere emissivity? Hint: Compare the relative heat rates by convection and radiation processes. (2) The steady-state temperature,  $T_{ss}$ , as a function of the convection coefficient for selected emissivities calculated using (2) is plotted below. Are these results consistent with the above plot of  $t_f$  vs  $h$ ?

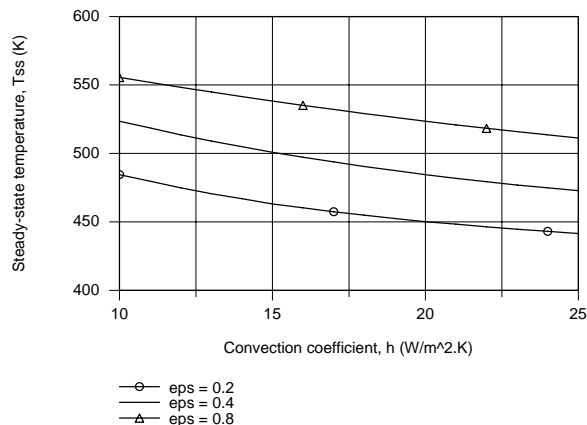

## PROBLEM 12.80

**KNOWN:** Thermograph with spectral response in 9 to 12  $\mu\text{m}$  region views a target of area  $200\text{mm}^2$  with solid angle  $0.001\text{ sr}$  in a normal direction.

**FIND:** (a) For a black surface at  $60^\circ\text{C}$ , the emissive power in 9 – 12  $\mu\text{m}$  spectral band, (b) Radiant power (W), received by thermograph when viewing black target at  $60^\circ\text{C}$ , (c) Radiant power (W) received by thermograph when viewing a gray, diffuse target having  $\epsilon = 0.7$  and considering the surroundings at  $T_{\text{sur}} = 23^\circ\text{C}$ .

**SCHEMATIC:**

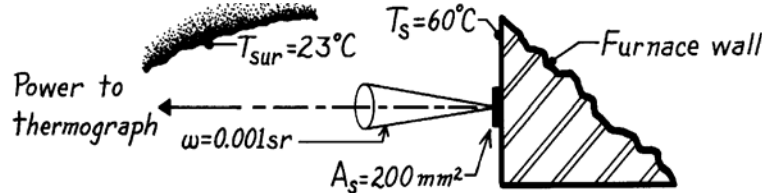

**ASSUMPTIONS:** (1) Wall is diffuse, (2) Surroundings are black with  $T_{\text{sur}} = 23^\circ\text{C}$ .

**ANALYSIS:** (a) Emissive power in spectral range 9 to 12  $\mu\text{m}$  for a  $60^\circ\text{C}$  black surface is

$$E_t \equiv E_b(9-12\ \mu\text{m}) = E_b [F(0 \rightarrow 12\ \mu\text{m}) - F(0 \rightarrow 9\ \mu\text{m})]$$

where  $E_b(T_s) = \sigma T_s^4$ . From Table 12.1:

$$\lambda_2 T_s = 12 \times (60 + 273) \approx 4000\ \mu\text{m K}, \quad F(0-12\ \mu\text{m}) = 0.481$$

$$\lambda_1 T_s = 9 \times (60 + 273) \approx 3000\ \mu\text{m K}, \quad F(0-9\ \mu\text{m}) = 0.273.$$

Hence

$$E_t = 5.667 \times 10^{-8}\ \text{W/m}^2 \cdot \text{K}^4 \times (60 + 273)^4\ \text{K}^4 [0.481 - 0.273] = 145\ \text{W/m}^2. \quad <$$

(b) The radiant power,  $q_b$  (W), received by the thermograph from a black target is determined as

$$q_b = \frac{E_t}{\pi} \cdot A_s \cos \theta_1 \cdot \omega$$

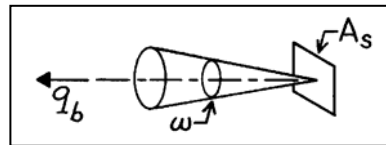

where

$E_t$  = emissive power in 9 – 12  $\mu\text{m}$  spectral region, part (a) result

$A_s$  = target area viewed by thermograph,  $200\text{mm}^2$  ( $2 \times 10^{-4}\ \text{m}^2$ )

$\omega$  = solid angle thermograph aperture subtends when viewed from the target,  $0.001\text{ sr}$

$\theta$  = angle between target area normal and view direction,  $0^\circ$ .

Hence,

$$q_b = \frac{145\ \text{W/m}^2}{\pi\ \text{sr}} \times (2 \times 10^{-4}\ \text{m}^2) \times \cos 0^\circ \times 0.001\ \text{sr} = 9.23\ \mu\text{W}. \quad <$$

Continued ...

### PROBLEM 12.80 (Cont.)

(c) When the target is a gray, diffuse emitter,  $\varepsilon = 0.7$ , the thermograph will receive emitted power from the target and reflected irradiation resulting from the surroundings at  $T_{\text{sur}} = 23^\circ\text{C}$ . Schematically:

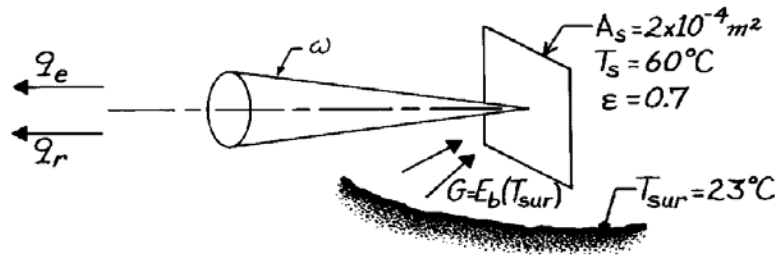

The power is expressed as

$$q = q_e + q_r = \varepsilon q_b + I_r \cdot A_s \cos \theta_1 \cdot \omega \left[ F_{(0 \rightarrow 12 \mu\text{m})} - F_{(0 \rightarrow 9 \mu\text{m})} \right]$$

where

$q_b$  = radiant power from black surface, part (b) result

$F_{(0-\lambda)}$  = band emission fraction for  $T_{\text{sur}} = 23^\circ\text{C}$ ; using Table 12.1

$$\lambda_2 T_{\text{sur}} = 12 \times (23 + 273) = 3552 \mu\text{m}\cdot\text{K}, F_{(0-\lambda_2)} = 0.394$$

$$\lambda_1 T_{\text{sur}} = 9 \times (23 + 273) = 2664 \mu\text{m}\cdot\text{K}, F_{(0-\lambda_1)} = 0.197$$

$I_r$  = reflected intensity, which because of diffuse nature of surface

$$I_r = \rho \frac{G}{\pi} = (1 - \varepsilon) \frac{E_b(T_{\text{sur}})}{\pi}.$$

Hence

$$q = 0.7 \times 9.23 \mu\text{W} + (1 - 0.7) \frac{5.667 \times 10^{-8} \text{ W/m}^2 \cdot \text{K}^4 \times (273 + 23)^4 \text{ K}}{\pi \text{ sr}} \\ \times (2 \times 10^{-4} \text{ m}^2) \times \cos 0^\circ \times 0.001 \text{ sr} [0.394 - 0.197]$$

$$q = 6.46 \mu\text{W} + 1.64 \mu\text{W} = 8.10 \mu\text{W}. \quad \leftarrow$$

**COMMENTS:** (1) Comparing the results of parts (a) and (b), note that the power to the thermograph is slightly less for the gray surface with  $\varepsilon = 0.7$ . From part (b) see that the effect of the irradiation is substantial; that is,  $1.64/8.10 \approx 20\%$  of the power received by the thermograph is due to reflected irradiation. Ignoring such effects leads to misinterpretation of temperature measurements using thermography. (2) Many thermography devices have a spectral response in the 3 to 5  $\mu\text{m}$  wavelength region as well as 9 – 12  $\mu\text{m}$ .

## PROBLEM 12.81

**KNOWN:** Radiation thermometer (RT) viewing a steel billet being heated in a furnace.

**FIND:** Temperature of the billet when the RT indicates 1160K.

**SCHEMATIC:**

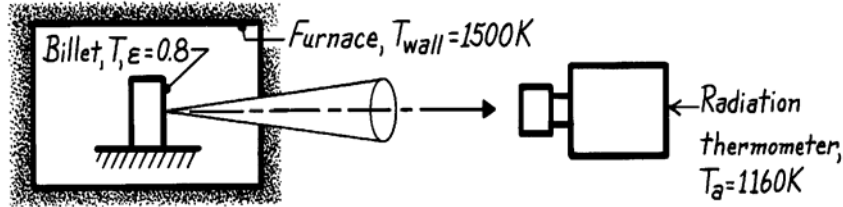

**ASSUMPTIONS:** (1) Billet is diffuse-gray, (2) Billet is small object in large enclosure, (3) Furnace behaves as isothermal, large enclosure, (4) RT is a radiometer sensitive to total (rather than a prescribed spectral band) radiation and is calibrated to correctly indicate the temperature of a black body, (5) RT receives radiant power originating from the target area on the billet.

**ANALYSIS:** The radiant power reaching the radiation thermometer (RT) is proportional to the radiosity of the billet. For the diffuse-gray billet within the large enclosure (furnace), the radiosity is

$$J = \varepsilon E_b(T) + \rho G = \varepsilon E_b(T) + (1 - \varepsilon) E_b(T_w)$$

$$J = \varepsilon \sigma T^4 + (1 - \varepsilon) \sigma T_w^4 \quad (1)$$

where  $\alpha = \varepsilon$ ,  $G = E_b(T_w)$  and  $E_b = \sigma T^4$ . When viewing the billet, the RT indicates  $T_a = 1100\text{K}$ , referred to as the apparent temperature of the billet. That is, the RT *indicates* the billet is a blackbody at  $T_a$  for which the radiosity will be

$$E_b(T_a) = J_a = \sigma T_a^4 \quad (2)$$

Recognizing that  $J_a = J$ , set Eqs. (1) and (2) equal to one another and solve for  $T$ , the billet true temperature.

$$T = \left[ \frac{1}{\varepsilon} T_a^4 - \frac{1 - \varepsilon}{\varepsilon} T_w^4 \right]^{1/4}$$

Substituting numerical values, find

$$T = \left[ \frac{1}{0.8} (1160\text{K})^4 - \frac{1 - 0.8}{0.8} (1500\text{K})^4 \right]^{1/4} = 999\text{K} \quad <$$

**COMMENTS:** (1) The effect of the reflected wall irradiation from the billet is to cause the RT to indicate a temperature higher than the true temperature.

(2) What temperature would the RT indicate when viewing the furnace wall assuming the wall emissivity were 0.85?

(3) What temperature would the RT indicate if the RT were sensitive to spectral radiation at  $0.65 \mu\text{m}$  instead of total radiation? Hint: in Eqs. (1) and (2) replace the emissive power terms with spectral intensity. Answer: 1365K.

## PROBLEM 12.82

**KNOWN:** Irradiation and temperature of a small surface.

**FIND:** Rate at which radiation is received by a detector due to emission and reflection from the surface.

**SCHEMATIC:**

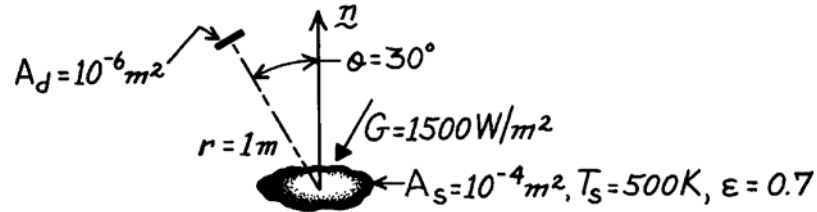

**ASSUMPTIONS:** (1) Opaque, diffuse-gray surface behavior, (2)  $A_s$  and  $A_d$  may be approximated as differential areas.

**ANALYSIS:** Radiation intercepted by the detector is due to emission and reflection from the surface, and from the definition of the intensity, it may be expressed as

$$q_{s-d} = I_{e+r} A_s \cos \theta \Delta \omega.$$

The solid angle intercepted by  $A_d$  with respect to a point on  $A_s$  is

$$\Delta \omega = \frac{A_d}{r^2} = 10^{-6} \text{ sr}.$$

Since the surface is diffuse it follows from Eq. 12.27 that

$$I_{e+r} = \frac{J}{\pi}$$

where, since the surface is opaque and gray ( $\epsilon = \alpha = 1 - \rho$ ),

$$J = E + \rho G = \epsilon E_b + (1 - \epsilon) G.$$

Substituting for  $E_b$  from Eq. 12.32

$$J = \epsilon \sigma T_s^4 + (1 - \epsilon) G = 0.7 \times 5.67 \times 10^{-8} \frac{\text{W}}{\text{m}^2 \cdot \text{K}^4} (500 \text{ K})^4 + 0.3 \times 1500 \frac{\text{W}}{\text{m}^2}$$

or

$$J = (2481 + 450) \text{ W/m}^2 = 2931 \text{ W/m}^2.$$

Hence

$$I_{e+r} = \frac{2931 \text{ W/m}^2}{\pi \text{ sr}} = 933 \text{ W/m}^2 \cdot \text{sr}$$

and

$$q_{s-d} = 933 \text{ W/m}^2 \cdot \text{sr} \left( 10^{-4} \text{ m}^2 \times 0.866 \right) 10^{-6} \text{ sr} = 8.08 \times 10^{-8} \text{ W}.$$

<

### PROBLEM 12.83

**KNOWN:** Small, diffuse, gray block with  $\varepsilon = 0.92$  at  $35^\circ\text{C}$  is located within a large oven whose walls are at  $175^\circ\text{C}$  with  $\varepsilon = 0.85$ .

**FIND:** Radiant power reaching detector when viewing (a) a deep hole in the block and (b) an area on the block's surface.

**SCHEMATIC:**

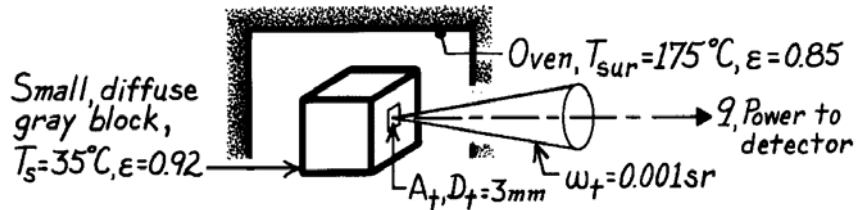

**ASSUMPTIONS:** (1) Block is isothermal, diffuse, gray and small compared to the enclosure, (2) Oven is isothermal enclosure.

**ANALYSIS:** (a) The small, deep hole in the isothermal block approximates a blackbody at  $T_s$ . The radiant power to the detector can be determined from Eq. 12.11 written in the form:

$$q = I_e \cdot A_t \cdot \omega_t = \frac{\sigma T_s^4}{\pi} \cdot A_t \cdot \omega_t$$

$$q = \frac{1}{\pi \text{ sr}} \left[ 5.67 \times 10^{-8} \times (35 + 273)^4 \right] \frac{\text{W}}{\text{m}^2} \times \frac{\pi (3 \times 10^{-3})^2 \text{ m}^2}{4} \times 0.001 \text{ sr} = 1.15 \mu\text{W} <$$

where  $A_t = \pi D_t^2 / 4$ . Note that the hole diameter must be greater than 3mm diameter.

(b) When the detector views an area on the surface of the block, the radiant power reaching the detector will be due to emission and reflected irradiation originating from the enclosure walls. In terms of the radiosity, Section 12.3.4, we can write using Eq. 12.23,

$$q = I_{e+r} \cdot A_t \cdot \omega_t = \frac{J}{\pi} \cdot A_t \cdot \omega_t.$$

Since the surface is diffuse and gray, the radiosity can be expressed as

$$J = \varepsilon E_b(T_s) + \rho G = \varepsilon E_b(T_s) + (1 - \varepsilon) E_b(T_{sur})$$

recognizing that  $\rho = 1 - \varepsilon$  and  $G = E_b(T_{sur})$ . The radiant power is

$$q = \frac{1}{\pi} \left[ \varepsilon E_b(T_s) + (1 - \varepsilon) E_b(T_{sur}) \right] \cdot A_t \cdot \omega_t$$

$$q = \frac{1}{\pi \text{ sr}} \left[ 0.92 \times 5.67 \times 10^{-8} (35 + 273)^4 + (1 - 0.92) \times 5.67 \times 10^{-8} (175 + 273)^4 \right] \text{W/m}^2 \times$$

$$\frac{\pi (3 \times 10^{-3})^2 \text{ m}^2}{4} \times 0.001 \text{ sr} = 1.47 \mu\text{W}. <$$

**COMMENTS:** The effect of reflected irradiation when  $\varepsilon < 1$  is important for objects in enclosures. The practical application is one of measuring temperature by radiation from objects within furnaces.

### PROBLEM 12.84

**KNOWN:** Diffuse, gray opaque disk (1) coaxial with a ring-shaped disk (2), both with prescribed temperatures and emissivities. Cooled detector disk (3), also coaxially positioned at a prescribed location.

**FIND:** Rate at which radiation is incident on the detector due to emission and reflection from  $A_1$ .

**SCHEMATIC:**

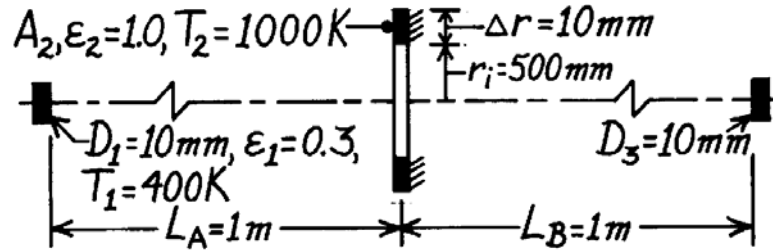

**ASSUMPTIONS:** (1)  $A_1$  is diffuse-gray, (2)  $A_2$  is black, (3)  $A_1$  and  $A_3 \ll R^2$ , the distance of separation, (4)  $\Delta r \ll r_i$ , such that  $A_2 \approx 2\pi r_i \Delta r$ , and (5) Backside of  $A_2$  is insulated.

**ANALYSIS:** The radiant power leaving  $A_1$  intercepted by  $A_3$  is of the form

$$q_{1 \rightarrow 3} = (J_1 / \pi) A_1 \cos \theta_1 \cdot \omega_{3-1}$$

where for this configuration of  $A_1$  and  $A_3$ ,

$$\theta_1 = 0^\circ \quad \omega_{3-1} = A_3 \cos \theta_3 / (L_A + L_B)^2 \quad \theta_3 = 0^\circ.$$

Hence,

$$q_{1 \rightarrow 3} = (J_1 / \pi) A_1 \cdot A_3 / (L_A + L_B)^2 \quad J_1 = \rho G_1 + \varepsilon E_b(T_1) = \rho G_1 + \varepsilon \sigma T_1^4.$$

The irradiation on  $A_1$  due to emission from  $A_2$ ,  $G_1$ , is

$$G_1 = q_{2 \rightarrow 1} / A_1 = (I_2 \cdot A_2 \cos \theta_2' \cdot \omega_{1-2}) / A_1$$

where

$$\omega_{1-2} = A_1 \cos \theta_1' / R^2$$

is constant over the surface  $A_2$ . From geometry,

$$\theta_1' = \theta_2' = \tan^{-1} [(r_i + \Delta r / 2) / L_A] = \tan^{-1} [(0.500 + 0.005) / 1.000] = 26.8^\circ$$

$$R = L_A / \cos \theta_1' = 1 \text{ m} / \cos 26.8^\circ = 1.12 \text{ m}.$$

Hence,

$$G_1 = (\sigma T_2^4 / \pi) A_2 \cos 26.8^\circ \cdot [A_1 \cos 26.8^\circ / (1.12 \text{ m})^2] / A_1 = 360.2 \text{ W/m}^2$$

using  $A_2 = 2\pi r_i \Delta r = 3.142 \times 10^{-2} \text{ m}^2$  and

$$J_1 = (1 - 0.3) \times 360.2 \text{ W/m}^2 + 0.3 \times 5.67 \times 10^{-8} \text{ W/m}^2 \cdot \text{K}^4 (400 \text{ K})^4 = 687.7 \text{ W/m}^2.$$

Hence the radiant power is

$$q_{1 \rightarrow 3} = (687.7 \text{ W/m}^2 / \pi) \left[ \pi (0.010 \text{ m})^2 / 4 \right]^2 / (1 \text{ m} + 1 \text{ m})^2 = 337.6 \times 10^{-9} \text{ W}. <$$

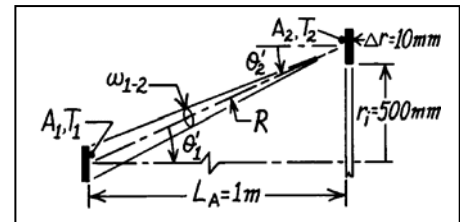

## PROBLEM 12.85

**KNOWN:** Infrared thermograph with a 3- to 5-micrometer spectral bandpass views a metal plate maintained at  $T_s = 327^\circ\text{C}$  having four diffuse, gray coatings of different emissivities. Surroundings at  $T_{\text{sur}} = 87^\circ\text{C}$ .

**FIND:** (a) Expression for the output signal,  $S_o$ , in terms of the responsivity,  $R$  ( $\mu\text{V}\cdot\text{m}^2/\text{W}$ ), the black coating ( $\epsilon_o = 1$ ) emissive power and appropriate band emission fractions; assuming  $R = 1 \mu\text{V}\cdot\text{m}^2/\text{W}$ , evaluate  $S_o(\text{V})$ ; (b) Expression for the output signal,  $S_c$ , in terms of the responsivity  $R$ , the blackbody emissive power of the coating, the blackbody emissive power of the surroundings, the coating emissivity,  $\epsilon_c$ , and appropriate band emission fractions; (c) Thermograph signals,  $S_c$  ( $\mu\text{V}$ ), when viewing with emissivities of 0.8, 0.5 and 0.2 assuming  $R = 1 \mu\text{V}\cdot\text{m}^2/\text{W}$ ; and (d) Apparent temperatures which the device will indicate based upon the signals found in part (c) for each of the three coatings.

**SCHEMATIC:**

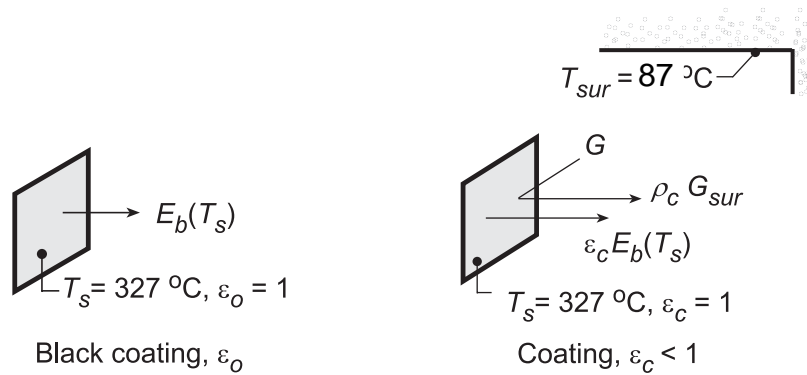

**ASSUMPTIONS:** (1) Plate has uniform temperature, (2) Surroundings are isothermal and large compared to the plate, and (3) Coatings are diffuse and gray so that  $\epsilon = \alpha$  and  $\rho = 1 - \epsilon$ .

**ANALYSIS:** (a) When viewing the black coating ( $\epsilon_o = 1$ ), the scanner output signal can be expressed as

$$S_o = R F(\lambda_1 - \lambda_2, T_s) E_b(T_s) \quad (1)$$

where  $R$  is the responsivity ( $\mu\text{V}\cdot\text{m}^2/\text{W}$ ),  $E_b(T_s)$  is the blackbody emissive power at  $T_s$  and  $F(\lambda_1 - \lambda_2, T_s)$  is the fraction of the spectral band between  $\lambda_1$  and  $\lambda_2$  in the spectrum for a blackbody at  $T_s$ ,

$$F(\lambda_1 - \lambda_2, T_s) = F(0 - \lambda_2, T_s) - F(0 - \lambda_1, T_s) \quad (2)$$

where the band fractions Eq. 12.35 are evaluated using Table 12.1 with  $\lambda_1 T_s = 3 \mu\text{m} (327 + 273)\text{K} = 1800 \mu\text{m}\cdot\text{K}$  ( $F_{0-\lambda_1} = 0.0393$ ) and  $\lambda_2 T_s = 5 \mu\text{m} (327 + 273) = 3000 \mu\text{m}\cdot\text{K}$  ( $F_{0-\lambda_2} = 0.2732$ ). Substituting numerical values with  $R = 1 \mu\text{V}\cdot\text{m}^2/\text{W}$ , find

$$S_o = 1 \mu\text{V}\cdot\text{m}^2/\text{W} [0.2732 - 0.0393] 5.67 \times 10^{-8} \text{W}/\text{m}^2 \cdot \text{K}^4 (600\text{K})^4$$

$$S_o = 1718 \mu\text{V} \quad <$$

(b) When viewing one of the coatings ( $\epsilon_c < \epsilon_o = 1$ ), the output signal as illustrated in the schematic above will be affected by the emission and reflected irradiation from the surroundings,

$$S_c = R \left\{ F(\lambda_1 - \lambda_2, T_s) \epsilon_c E_b(T_s) + F(\lambda_1 - \lambda_2, T_{\text{sur}}) \rho_c G_c \right\} \quad (3)$$

where the reflected irradiation parameters are

Continued...



**PROBLEM 12.85 (Cont.)**

$$\rho_c = 1 - \varepsilon_c \quad G_c = \sigma T_{\text{sur}}^4 \quad (4,5)$$

and the related band fractions are

$$F(\lambda_1 - \lambda_2, T_{\text{sur}}) = F(0 - \lambda_2, T_{\text{sur}}) - F(0 - \lambda_1, T_{\text{sur}}) \quad (6)$$

Combining Eqs. (2-6) above, the scanner output signal when viewing a coating is

$$S_c = R \left\{ \left[ F(0 - \lambda_2, T_s) - F(0 - \lambda_1, T_s) \right] \varepsilon_c \sigma T_s^4 + \left[ F(0 - \lambda_2, T_{\text{sur}}) - F(0 - \lambda_1, T_{\text{sur}}) \right] (1 - \varepsilon_c) \sigma T_{\text{sur}}^4 \right\} \quad (7)$$

(c) Substituting numerical values into Eq. (7), find

$$S_c = 1 \mu\text{V} \cdot \text{m}^2 / \text{W} \left\{ [0.2732 - 0.0393] \varepsilon_c \sigma (600\text{K})^4 + [0.0393 - 0.0010] (1 - \varepsilon_c) \sigma (360\text{K})^4 \right\}$$

where for  $\lambda_2 T_{\text{sur}} = 5 \mu\text{m} \times 360 \text{K} = 1800 \mu\text{m} \cdot \text{K}$ ,  $F(0 - \lambda_2, T_{\text{sur}}) = 0.0393$  and  $\lambda_1 T_{\text{sur}} = 3 \mu\text{m} \times 360 \text{K} = 1080 \mu\text{m} \cdot \text{K}$ ,  $F(0 - \lambda_1, T_{\text{sur}}) = 0.0010$ . For  $\varepsilon_c = 0.80$ , find

$$S_c (\varepsilon_c = 0.8) = 1 \mu\text{V} \cdot \text{m}^2 / \text{W} \{1375 + 7.295\} \text{W} / \text{m}^2 = 1382 \mu\text{V} \quad <$$

$$S_c (\varepsilon_c = 0.5) = 1 \mu\text{V} \cdot \text{m}^2 / \text{W} \{859.4 + 18.238\} \text{W} / \text{m}^2 = 878 \mu\text{V} \quad <$$

$$S_c (\varepsilon_c = 0.2) = 1 \mu\text{V} \cdot \text{m}^2 / \text{W} \{343.8 + 29.180\} \text{W} / \text{m}^2 = 373 \mu\text{V} \quad <$$

(d) The thermograph calibrated against a black surface ( $\varepsilon_1 = 1$ ) interprets the radiation reaching the detector by emission and reflected radiation from a coating target ( $\varepsilon_c < \varepsilon_o$ ) as that from a blackbody at an apparent temperature  $T_a$ . That is,

$$S_c = R F(\lambda_1 - \lambda_2, T_a) E_b(T_a) = R \left[ F(0 - \lambda_2, T_a) - F(0 - \lambda_1, T_a) \right] \sigma T_a^4 \quad (8)$$

For each of the coatings in part (c), solving Eq. (8) using the IHT workspace with the *Radiation Tool, Band Emission Factor*, the following results were obtained,

$\varepsilon_c$	$S_c$ ( $\mu\text{V}$ )	$T_a$ (K)	$T_a - T_s$ (K)
0.8	1382	579.3	-20.7
0.5	878	539.2	-60.8
0.2	373	476.7	-123.3

**COMMENTS:** (1) From part (c) results for  $S_c$ , note that the contribution of the reflected irradiation becomes relatively more significant with lower values of  $\varepsilon_c$ .

(2) From part (d) results for the apparent temperature, note that the error,  $(T - T_a)$ , becomes larger with decreasing  $\varepsilon_c$ . By rewriting Eq. (8) to include the emissivity of the coating,

$$S'_c = R \left[ F(0 - \lambda_2, T_a) - F(0 - \lambda_1, T_a) \right] \varepsilon_c \sigma T_a^4$$

The apparent temperature  $T'_a$  will be influenced only by the reflected irradiation. The results correcting only for the emissivity,  $\varepsilon_c$ , are

$\varepsilon_c$	0.8	0.5	0.2
$T'_a$ (K)	600.5	602.2	608.5
$T'_a - T_s$ (K)	+0.5	+2.2	+8.5

## PROBLEM 12.86

**KNOWN:** Spectral range of a CCD device used for infrared temperature measurement, thickness of quartz window, transmissivity of polyethylene sheet, emissivity of painted aluminum billet, temperatures of the billet, window and surroundings.

**FIND:** (a) Temperature indicated by the CCD device when quartz window is used, (b) Temperature indicated by the CCD device when polyethylene window is used.

**SCHEMATIC:**

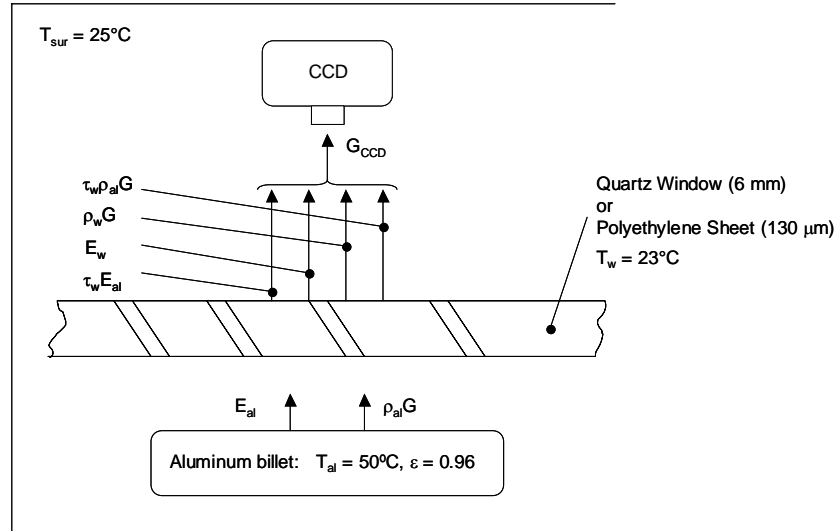

**ASSUMPTIONS:** (1) Large surroundings, (2) Diffuse surfaces, (3) Radiative properties do not vary in the spectral range of the CCD device, (4) Reflection from bottom of window is negligible.

**ANALYSIS:** (a) In the spectral range of the CCD detector,

$$G_{\text{CCD},9-12} = \tau_w E_{\text{al}} \left[ F_{(0-12\mu\text{m})} - F_{(0-9\mu\text{m})} \right] + E_w \left[ F_{(0-12\mu\text{m})} - F_{(0-9\mu\text{m})} \right] + \rho_w G \left[ F_{(0-12\mu\text{m})} - F_{(0-9\mu\text{m})} \right] + \tau_w \rho_{\text{al}} G \left[ F_{(0-12\mu\text{m})} - F_{(0-9\mu\text{m})} \right] \quad (1)$$

From Figure 12.23,  $\tau_w \approx 0$  in the spectral range ( $9 \mu\text{m} \leq \lambda \leq 12 \mu\text{m}$ ). Hence, Equation 1 becomes

$$G_{\text{CCD},9-12} = \left[ F_{(0-12\mu\text{m})} - F_{(0-9\mu\text{m})} \right] \left[ \varepsilon_w \sigma T_w^4 + \rho_w \sigma T_{\text{sur}}^4 \right]$$

Since  $\alpha_w + \rho_w = 1$  and  $\alpha_w = \varepsilon_w$  for a diffuse surface that is at the same temperature at the surroundings (see Equation 12.36) it follows that

$$G_{\text{CCD},9-12} = \left[ F_{(0-12\mu\text{m})} - F_{(0-9\mu\text{m})} \right] \sigma T_{\text{sur}}^4 = \left[ F_{(0-12\mu\text{m})} - F_{(0-9\mu\text{m})} \right] \sigma T_d^4$$

where  $T_d$  is the temperature indicated by the detector. Hence,  $T_d = T_{\text{sur}} = 23^\circ\text{C}$ .

<

Continued...

### PROBLEM 12.86 (Cont.)

(b) With the polyethylene sheet as the window and an aluminum temperature of  $T_{al} = 50^\circ\text{C} + 273$  K = 323 K,

$$G_{\text{CCD},9-12} = \tau_w \varepsilon_{al} \sigma T_{al}^4 \left[ F_{(0-12\mu\text{m},323\text{K})} - F_{(0-9\mu\text{m},323\text{K})} \right] + \varepsilon_w \sigma T_w^4 \left[ F_{(0-12\mu\text{m},300\text{K})} - F_{(0-9\mu\text{m},300\text{K})} \right] \\ + \rho_w \sigma T_{sur}^4 \left[ F_{(0-12\mu\text{m},300\text{K})} - F_{(0-9\mu\text{m},300\text{K})} \right] + \tau_w \rho_{al} \sigma T_{sur}^4 \left[ F_{(0-12\mu\text{m},300\text{K})} - F_{(0-9\mu\text{m},300\text{K})} \right]$$

For the window,  $\alpha_w + \rho_w + \tau_w = 1$ . Since  $\alpha_{\lambda,w} = \varepsilon_{\lambda,w}$  for the diffuse surface and since  $T_w = T_{sur}$ ,  $\alpha_w = \varepsilon_w$  as evident in Equation 12.43. Hence,

$$G_{\text{CCD},9-12} = \left[ F_{(0-12\mu\text{m},T_d)} - F_{(0-9\mu\text{m},T_d)} \right] \sigma T_d^4 = \tau_w \varepsilon_{al} \sigma T_{al}^4 \left[ F_{(0-12\mu\text{m},323\text{K})} - F_{(0-9\mu\text{m},323\text{K})} \right] \\ + \sigma T_{sur}^4 (1 - \tau_w) \left[ F_{(0-12\mu\text{m},300\text{K})} - F_{(0-9\mu\text{m},300\text{K})} \right] + \tau_w (1 - \varepsilon_{al}) \sigma T_{sur}^4 \left[ F_{(0-12\mu\text{m},300\text{K})} - F_{(0-9\mu\text{m},300\text{K})} \right]$$

or

$$T_d = \left[ \frac{\tau_w \varepsilon_{al} T_{al}^4 \left[ F_{(0-12\mu\text{m},323\text{K})} - F_{(0-9\mu\text{m},323\text{K})} \right] + (1 - \tau_w \varepsilon_{al}) T_{sur}^4 \left[ F_{(0-12\mu\text{m},300\text{K})} - F_{(0-9\mu\text{m},300\text{K})} \right]}{\left[ F_{(0-12\mu\text{m},T_d)} - F_{(0-9\mu\text{m},T_d)} \right]} \right]^{1/4}$$

Substituting values,

$$T_d = \left[ \frac{0.78 \times 0.96 \times (323\text{K})^4 [0.4576 - 0.2521] + (1 - 0.78 \times 0.96) \times (300\text{K})^4 [0.4036 - 0.2055]}{\left[ F_{(0-12\mu\text{m},T_d)} - F_{(0-9\mu\text{m},T_d)} \right]} \right]^{1/4}$$

A trial-and-error solution, or solution using IHT yields

$$T_d = 317.6 \text{ K} = 44.6^\circ\text{C}$$

<

**COMMENTS:** (1) Materials that are transparent in the visible spectrum, such as quartz, are often opaque in the infrared part of the spectrum. The quartz window does not allow the warm billet to be viewed by the CCD device. (2) This analysis could be extended to calibrate the CCD device so that the indicated temperature is identical to the actual temperature.

## PROBLEM 12.87

**KNOWN:** Diameter, emissivity and temperature of a spherical object. Aperture areas, locations, and spectral transmissivity of the optics of two detectors. Surroundings temperature and irradiation detected at two times.

**FIND:** Velocity of the object, location and time at which the object will strike the  $y = 0$  plane.

**SCHEMATIC:**

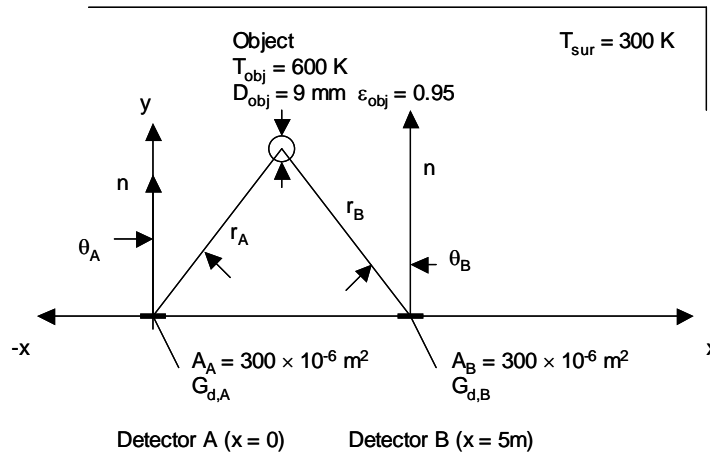

**ASSUMPTIONS:** (1) Diffuse object, (2) Object travels in a straight line, (3) Object is located above  $y = 2$  m.

**ANALYSIS:** We begin by analyzing the situation at time  $t = 0$ . For Detector A, the irradiation that is detected,  $G_{d,A}$ , is composed of irradiation from the surroundings,  $G_{sur}$ , and irradiation from the object,  $G_{obj}$ . Hence,  $G_{d,A} = G_{sur,d,A} + G_{obj,d,A}$ . The irradiation from the surroundings that is detected is

$$G_{sur,d,A} = \pi I_b F_{(0-2.5\mu m)} \tau_\lambda = E_b(300K) F_{(0-2.5\mu m)} \tau_\lambda$$

$$= 5.67 \times 10^{-8} \text{ W/m}^2 \cdot \text{K}^4 \times 300^4 \text{ K}^4 \times 1.2 \times 10^{-5} \times 0.9 = 4.96 \times 10^{-3} \text{ W/m}^2$$

Therefore,  $G_{obj,d,A} = 5.06 \times 10^{-3} \text{ W/m}^2 - 4.96 \times 10^{-3} \text{ W/m}^2 = 100 \times 10^{-6} \text{ W/m}^2$ . Proceeding as in Example 12.1,

$$G_{obj,d,A} = \left[ I_{obj} A_{obj} \cos \theta_{obj} A_A \cos \theta_A / A_A r_A^2 \right] \times F_{(0-2.5\mu m)} \tau_\lambda$$

Since the projected area of the sphere is a circle,  $A_{obj} \cos \theta_{obj} = \pi D_{obj}^2 / 4$ . In addition,

$I_{obj} = \epsilon_{obj} \sigma T_{obj}^4 / 4$ . Therefore,

Continued...

**PROBLEM 12.87 (Cont.)**

$$100 \times 10^{-6} \text{ W/m}^2 = \left[ 0.95 \times 5.67 \times 10^{-8} \text{ W/m}^2 \cdot \text{K}^4 \times (600\text{K})^4 \times (9 \times 10^{-3} \text{ m})^2 \times \cos \theta_A \times 0.01375 \times 0.9 \right] / 4r_A^2$$

Simplifying the preceding expression results in

$$\frac{\cos \theta_A}{r_A^2} = 57.14 \times 10^{-3} \text{ m}^{-2} \quad (1)$$

We also note that

$$x_{\text{obj},1} = r_A \sin \theta_A, \quad y_{\text{obj},1} = r_A \cos \theta_A \quad (2,3)$$

where  $x_{\text{obj},1}$  and  $y_{\text{obj},1}$  are the x- and y-locations of the object. For Detector B,  $G_{\text{d},B} = G_{\text{sur},\text{d},B} + G_{\text{obj},\text{d},B}$  where  $G_{\text{sur},\text{d},B} = G_{\text{sur},\text{d},A} = 4.96 \times 10^{-3} \text{ W/m}^2$ . Therefore,  $G_{\text{obj},\text{d},B} = 5.00 \times 10^{-3} \text{ W/m}^2 - 4.96 \times 10^{-3} \text{ W/m}^2 = 40 \times 10^{-6} \text{ W/m}^2$ . As for Detector A,

$$G_{\text{obj},\text{d},B} = \left[ I_{\text{obj}} A_{\text{obj}} \cos \theta_{\text{obj}} A_B \cos \theta_B / A_B r_B^2 \right] \times F_{(0-2.5\mu\text{m})} \tau_\lambda$$

Therefore,

$$40 \times 10^{-6} \text{ W/m}^2 = \left[ 0.95 \times 5.67 \times 10^{-8} \text{ W/m}^2 \cdot \text{K}^4 \times (600\text{K})^4 \times (9 \times 10^{-3} \text{ m})^2 \times \cos \theta_B \times 0.01375 \times 0.9 \right] / 4r_B^2$$

Simplifying the preceding expression results in

$$\frac{\cos \theta_B}{r_B^2} = 22.86 \times 10^{-3} \text{ m}^{-2} \quad (4)$$

where

$$x_{\text{obj},1} = r_B \sin \theta_B + 5\text{m}, \quad y_{\text{obj},1} = r_B \cos \theta_B \quad (5,6)$$

Equations 1 through 3 may be solved simultaneously to find all possible positions of the object at  $t = 0$ , as determined from Detector A. Equations 4 through 6 may be solved simultaneously to find all possible positions of the object at  $t = 0$ , as determined from Detector B. These results are plotted below in the first graph. Note that there are two possible locations. Since we know the object is located above  $y = 2 \text{ m}$ , the object is located at the single position shown, which corresponds to  $x_{\text{obj}} = 1.078 \text{ m}$ ,  $y_{\text{obj}} = 3.965 \text{ m}$ .

Now, consider  $t = 4 \text{ ms}$ . The analysis proceeds as for  $t = 0$ , resulting in

$$\frac{\cos \theta_A}{r_A^2} = 28.57 \times 10^{-3} \text{ m}^{-2} \quad (7)$$

$$x_{\text{obj},2} = r_A \sin \theta_A, \quad y_{\text{obj},2} = r_A \cos \theta_A \quad (8,9)$$

$$\frac{\cos \theta_B}{r_B^2} = 51.43 \times 10^{-3} \text{ m}^{-2} \quad (10)$$

Continued...

### PROBLEM 12.87 (Cont.)

$$x_{\text{obj},2} = r_B \sin \theta_B + 5 \text{ m}, \quad y_{\text{obj},2} = r_B \cos \theta_B \quad (11,12)$$

Equations 7 through 9 may be solved simultaneously to find all possible positions of the object at  $t = 4 \text{ ms}$  as determined from Detector A. Equations 10 through 12 may be solved to find all possible positions at  $t = 4 \text{ ms}$ , as determined from Detector B. The two possible positions are shown in the second plot below. Since the object is located above  $y = 2 \text{ m}$ , the object is at the single position shown, which is  $x_{\text{obj},2} = 3.360 \text{ m}$ ,  $y_{\text{obj},2} = 3.903 \text{ m}$ .

The velocity components of the object are

$$v_x = \frac{(x_{\text{obj},2} - x_{\text{obj},1})}{\Delta t} = \frac{(3.360 \text{ m} - 1.078 \text{ m})}{4 \times 10^{-3} \text{ s}} = 571 \text{ m/s} \quad <$$

$$v_y = \frac{(y_{\text{obj},2} - y_{\text{obj},1})}{\Delta t} = \frac{(3.903 \text{ m} - 3.965 \text{ m})}{4 \times 10^{-3} \text{ s}} = -15.5 \text{ m/s} \quad <$$

The object's time of flight is  $t_f = y_{\text{obj},1} / |v_y| = 3.965 \text{ m} / 15.5 \text{ m/s} = 0.256 \text{ s}$  and the object will travel a distance of  $d = v_x t_f = 570.5 \text{ m} \times 0.256 \text{ s} = 146 \text{ m}$ . <

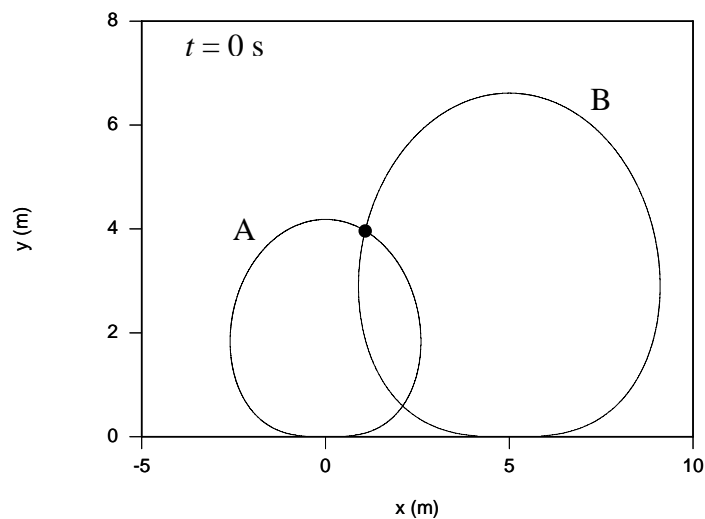

Continued...

**PROBLEM 12.87 (Cont.)**

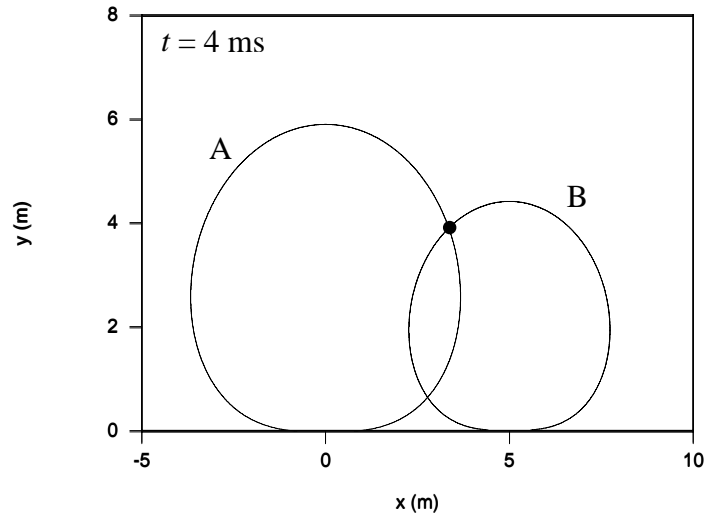

**COMMENTS:** (1) This is known as an “inverse” problem. Multiple solutions exist to such problems. (2) Use of a third detector would allow one to determine the object’s position in three-dimensional space.

## PROBLEM 12.88

**KNOWN:** Sample at  $T_s = 700$  K with ring-shaped cold shield viewed normally by a radiation detector.

**FIND:** (a) Shield temperature,  $T_{sh}$ , required so that its emitted radiation is 1% of the total radiant power received by the detector, and (b) Compute and plot  $T_{sh}$  as a function of the sample emissivity for the range  $0.05 \leq \epsilon \leq 0.35$  subject to the parametric constraint that the radiation emitted from the cold shield is 0.05, 1 or 1.5% of the total radiation received by the detector.

**SCHEMATIC:**

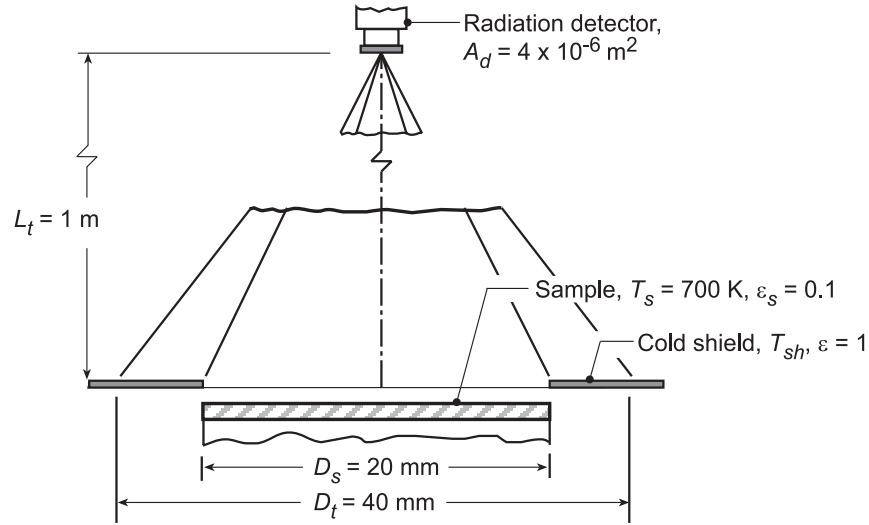

**ASSUMPTIONS:** (1) Sample is diffuse and gray, (2) Cold shield is black, and (3)  $A_d, D_s^2, D_t^2 \ll L_t^2$ .

**ANALYSIS:** (a) The radiant power intercepted by the detector from within the target area is

$$q_d = q_{s \rightarrow d} + q_{sh \rightarrow d}$$

The contribution from the sample is

$$q_{s \rightarrow d} = I_{s,e} A_s \cos \theta_s \Delta \omega_{d-s} \quad \theta_s = 0^\circ$$

$$I_{s,e} = \epsilon_s E_b / \pi = \epsilon_s \sigma T_s^4 / \pi$$

$$\Delta \omega_{d-s} = \frac{A_d \cos \theta_d}{L_t^2} = \frac{A_d}{L_t^2} \quad \theta_d = 0^\circ$$

$$q_{s \rightarrow d} = \epsilon_s \sigma T_s^4 A_s A_d / \pi L_t^2 \quad (1)$$

The contribution from the ring-shaped cold shield is

$$q_{sh \rightarrow d} = I_{sh,e} A_{sh} \cos \theta_{sh} \Delta \omega_{d-sh}$$

$$I_{sh,e} = E_b / \pi = \sigma T_{sh}^4 / \pi$$

and, from the geometry of the shield -detector,

$$A_{sh} = \frac{\pi}{4} (D_t^2 - D_s^2)$$

$$\cos \theta_{sh} = L_t / \left[ \left( \bar{D} / 2 \right)^2 + L_t^2 \right]^{1/2}$$

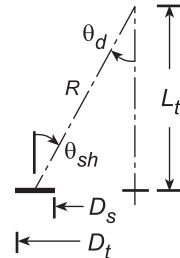

Continued...



### PROBLEM 12.88 (Cont.)

where  $\bar{D} = (D_s + D_t)/2$

$$\Delta\omega_{d-sh} = \frac{A_d \cos\theta_d}{R^2} \quad \cos\theta_d = \cos\theta_{sh}$$

where  $R = [L_t^2 + \bar{D}^2]^{1/2}$

$$q_{sh \rightarrow d} = \frac{\sigma T_{sh}^4}{\pi} A_{sh} \left[ \frac{L_t}{[(D_s + D_t)/4]^2 + L_t^2} \right]^2 \frac{A_d}{[(D_s + D_t)/4]^2 + L_t^2} \quad (2)$$

The requirement that the emitted radiation from the cold shield is 1% of the total radiation intercepted by the detector is expressed as

$$\frac{q_{sh-d}}{q_{tot}} = \frac{q_{sh-d}}{q_{sh-d} + q_{s-d}} = 0.01 \quad (3)$$

By evaluating Eq. (3) using Eqs. (1) and (3), find

$$T_{sh} = 134 \text{ K}$$

(b) Using the foregoing equations in the IHT workspace, the required shield temperature for  $q_{sh-d}/q_{tot} = 0.5, 1$  or  $1.5\%$  was computed and plotted as a function of the sample emissivity.

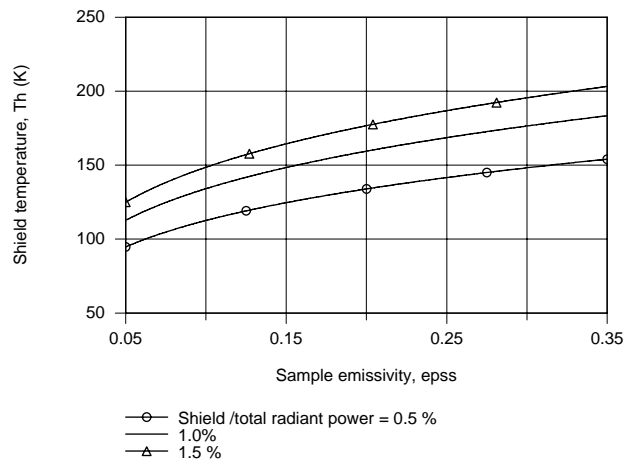

As the shield emission-to-total radiant power ratio decreases ( from 1.5 to 0.5% ), the required shield temperature decreases. The required shield temperature increases with increasing sample emissivity for a fixed ratio.

## PROBLEM 12.89

**KNOWN:** Wavelengths associated with a two-color pyrometer.

**FIND:** The ratio of intensities emitted by the surface at nominal wavelength of  $\lambda = 5 \mu\text{m}$  and  $\Delta\lambda = 0.1, 0.5$  and  $1 \mu\text{m}$ .

**ASSUMPTIONS:** Surface is hot relative to the surroundings so that reflection is negligible relative to emission.

**ANALYSIS:** The spectral intensity emitted by the surface is

$$I_{\lambda,e} = \varepsilon_{\lambda} I_{\lambda,b}(\lambda, T) = \frac{\varepsilon_{\lambda} 2hc_o^2}{\lambda^5 [\exp(hc_o / \lambda kT) - 1]}$$

Assuming the spectral emissivity is independent of wavelength over  $\Delta\lambda$ , the intensity ratio, R, is

$$R = \frac{\lambda^5 [\exp(hc_o / \lambda kT) - 1]}{(\lambda + \Delta\lambda)^5 [\exp(hc_o / (\lambda + \Delta\lambda) kT) - 1]}$$

with  $h = 6.626 \times 10^{-34} \text{ J}\cdot\text{s}$ ,  $k = 1.381 \times 10^{-23} \text{ J/K}$ ,  $c_o = 2.998 \times 10^8 \text{ m/s}$ ,  $\lambda = 5 \mu\text{m}$  and  $\Delta\lambda = 0.1, 0.5$  and  $1.0 \mu\text{m}$ , the variation of R over the range  $500 \text{ K} \leq T \leq 1000 \text{ K}$  is shown below.

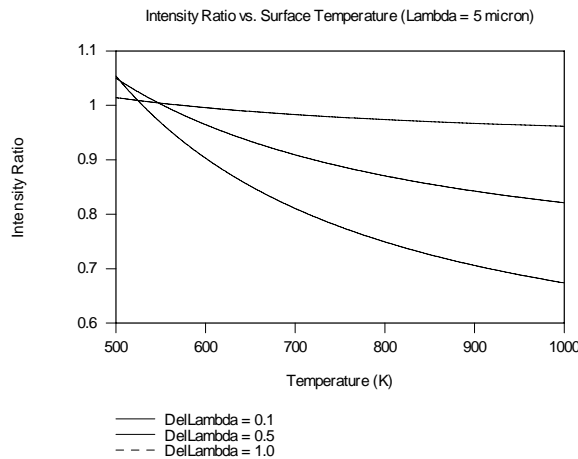

As  $\Delta\lambda$  increases, the ratio of intensities exhibits higher sensitivity to the surface temperature. However, a tradeoff exists since the assumption of uniform spectral emissivity over  $\Delta\lambda$  becomes less robust as the difference between  $\lambda_1$  and  $\lambda_2$  becomes large.

**COMMENTS:** (1) The pyrometer will also detect the reflection from the surface. If the surface reflectivity is large, or if the surface is cold relative to the surroundings, care must be made when interpreting the detector's output. (2) Care should be taken if the surface emissivity exhibits highly spectral behavior. (3) The intensity ratio is greater than unity at relatively low temperatures and less than unity at higher temperatures. Can you explain why?

### PROBLEM 12.90

**KNOWN:** Two wavelength values associated with a two-color pyrometer. Ratio of detected radiation from stainless steel.

**FIND:** Temperature of stainless steel.

**ASSUMPTIONS:** (1) Surface is hot relative to the surroundings so that reflection is negligible relative to emission, (2) Wien's law holds, (3) Emissivity does not vary greatly over the wavelength range associated with the pyrometer.

**ANALYSIS:** From Problem 12.27, Wien's law is

$$E_{\lambda,b} \approx \frac{C_1}{\lambda^5} \exp\left(-\frac{C_2}{\lambda T}\right)$$

The detected radiation flux is equal to the radiation flux emitted from the steel surface, since reflection has been assumed negligible. The ratio of intensities is equal to the ratio of emissive power (since  $I_\lambda = \pi E_\lambda$ ). Thus,

$$\frac{I_{\lambda_1}}{I_{\lambda_2}} = \frac{E_{\lambda_1}}{E_{\lambda_2}} = \frac{\varepsilon_1 E_{\lambda_1,b}}{\varepsilon_2 E_{\lambda_2,b}} = \frac{\lambda_2^5}{\lambda_1^5} \exp\left[-\frac{C_2}{T} \left(\frac{1}{\lambda_1} - \frac{1}{\lambda_2}\right)\right] = 2.15$$

where the assumption  $\varepsilon_1 \approx \varepsilon_2$  has been used. Solving for  $T$ ,

$$T = C_2 \frac{\left(\frac{1}{\lambda_2} - \frac{1}{\lambda_1}\right)}{\ln\left(2.15 \frac{\lambda_1^5}{\lambda_2^5}\right)} = 1.439 \times 10^4 \mu\text{m} \cdot \text{K} \frac{\left(\frac{1}{0.63 \mu\text{m}} - \frac{1}{0.65 \mu\text{m}}\right)}{\ln\left(2.15 \left(\frac{0.65 \mu\text{m}}{0.63 \mu\text{m}}\right)^5\right)} = 762 \text{ K} \quad <$$

**COMMENTS:** Comparing Eq. 12.30 to Wien's law, it can be seen that Wien's law is accurate provided that  $\exp(C_2/\lambda T) \gg 1$ . For the conditions of this problem,  $\exp(C_2/\lambda_1 T) = 4 \times 10^{12}$  and Wien's law is highly accurate.

## PROBLEM 12.91

**KNOWN:** Painted plate located inside a large enclosure being heated by an infrared lamp bank.

**FIND:** (a) Lamp irradiation required to maintain plot at  $T_s = 140^\circ\text{C}$  for the prescribed convection and enclosure irradiation conditions, (b) Compute and plot the lamp irradiation,  $G_{\text{lamp}}$ , required as a function of the plate temperature,  $T_s$ , for the range  $100 \leq T_s \leq 300^\circ\text{C}$  and for convection coefficients of  $h = 15, 20$  and  $30 \text{ W/m}^2\cdot\text{K}$ , and (c) Compute and plot the air stream temperature,  $T_\infty$ , required to maintain the plate at  $140^\circ\text{C}$  as a function of the convection coefficient  $h$  for the range  $10 \leq h \leq 30 \text{ W/m}^2\cdot\text{K}$  with a lamp irradiation  $G_{\text{lamp}} = 3000 \text{ W/m}^2$ .

**SCHEMATIC:**

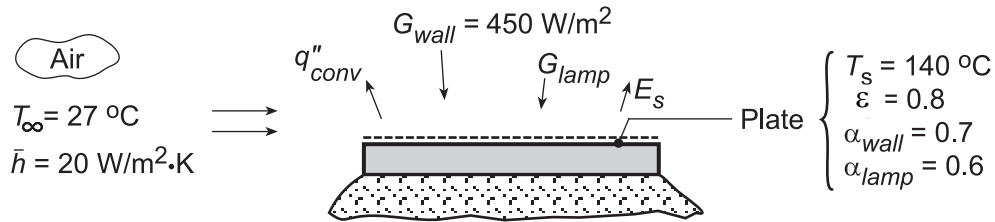

**ASSUMPTIONS:** (1) Steady-state conditions, (2) No losses on backside of plate.

**ANALYSIS:** (a) Perform an energy balance on the plate, per unit area,

$$\dot{E}_{\text{in}} - \dot{E}_{\text{out}} = 0 \quad (1)$$

$$\alpha_{\text{wall}} \cdot G_{\text{wall}} + \alpha_{\text{lamp}} G_{\text{lamp}} - q''_{\text{conv}} - E_s = 0 \quad (2)$$

where the emissive power of the surface and convective fluxes are

$$E_s = \epsilon_s E_b(T_s) = \epsilon_s \cdot \sigma T_s^4 \quad q''_{\text{conv}} = h(T_s - T_\infty) \quad (3,4)$$

Substituting values, find the lamp irradiation

$$0.7 \times 450 \text{ W/m}^2 + 0.6 \times G_{\text{lamp}} - 20 \text{ W/m}^2 \cdot \text{K} (413 - 300) \text{ K} - 0.8 \times 5.67 \times 10^{-8} \text{ W/m}^2 \cdot \text{K}^4 (413 \text{ K})^4 = 0 \quad (5)$$

$$G_{\text{lamp}} = 5441 \text{ W/m}^2 \quad \leftarrow$$

(b) Using the foregoing equations in the IHT workspace, the irradiation,  $G_{\text{lamp}}$ , required to maintain the plate temperature in the range  $100 \leq T_s \leq 300^\circ\text{C}$  for selected convection coefficients was computed. The results are plotted below.

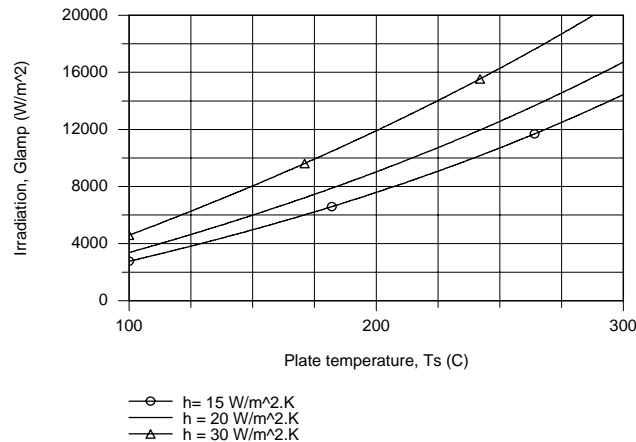

Continued...

### PROBLEM 12.91 (Cont.)

As expected, to maintain the plate at higher temperatures, the lamp irradiation must be increased. At any plate operating temperature condition, the lamp irradiation must be increased if the convection coefficient increases. With forced convection (say,  $h \geq 20 \text{ W/m}^2\cdot\text{K}$ ) of the airstream at  $27^\circ\text{C}$ , excessive irradiation levels are required to maintain the plate above the cure temperature of  $140^\circ\text{C}$ .

(c) Using the IHT model developed for part (b), the airstream temperature,  $T_\infty$ , required to maintain the plate at  $T_s = 140^\circ\text{C}$  as a function of the convection coefficient with  $G_{\text{lamp}} = 3000 \text{ W/m}^2\cdot\text{K}$  was computed and the results are plotted below.

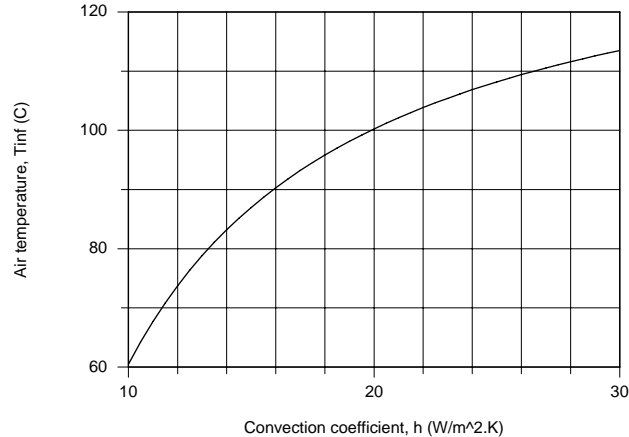

As the convection coefficient increases, for example by increasing the airstream velocity over the plate, the required air temperature must increase. Give a physical explanation for why this is so.

**COMMENTS:** (1) For a spectrally selective surface, we should expect the absorptivity to depend upon the spectral distribution of the source and  $\alpha \neq \varepsilon$ .

(2) Note the new terms used in this problem; use your Glossary, Section 12.10 to reinforce their meaning.

## PROBLEM 12.92

**KNOWN:** Small sample of reflectivity,  $\rho_\lambda$ , and diameter,  $D$ , is irradiated with an isothermal enclosure at  $T_f$ .

**FIND:** (a) Absorptivity,  $\alpha$ , of the sample with prescribed  $\rho_\lambda$ , (b) Emissivity,  $\varepsilon$ , of the sample, (c) Heat removed by coolant to the sample, (d) Explanation of why system provides a measure of  $\rho_\lambda$ .

**SCHEMATIC:**

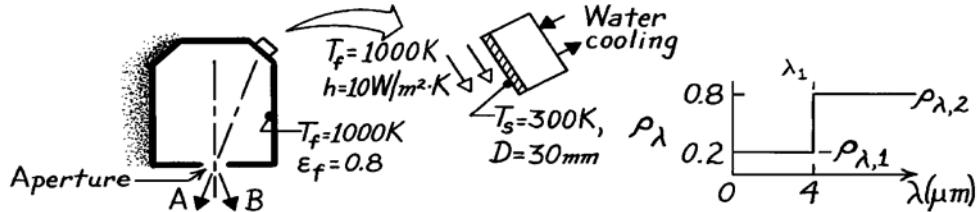

**ASSUMPTIONS:** (1) Sample is diffuse and opaque, (2) Furnace is an isothermal enclosure with area much larger than the sample, (3) Aperture of furnace is small.

**ANALYSIS:** (a) The absorptivity,  $\alpha$ , follows from Eq. 12.48, where the irradiation on the sample is  $G = E_b(T_f)$  and  $\alpha_\lambda = 1 - \rho_\lambda$ .

$$\alpha = \int_0^\infty \alpha_\lambda G_\lambda d\lambda / G = \int_0^\infty (1 - \rho_\lambda) E_{\lambda,b}(\lambda, 1000\text{K}) d\lambda / E_b(1000\text{K})$$

$$\alpha = (1 - \rho_{\lambda,1}) F_{(0 \rightarrow \lambda_1)} + (1 - \rho_{\lambda,2}) [1 - F_{(0 \rightarrow \lambda_1)}]$$

Using Table 12.1 for  $\lambda_1 T_f = 4 \times 1000 = 4000 \mu\text{m}\cdot\text{K}$ ,  $F_{(0-\lambda)} = 0.481$  giving

$$\alpha = (1 - 0.2) \times 0.481 + (1 - 0.8) \times (1 - 0.481) = 0.49. \quad <$$

(b) The emissivity,  $\varepsilon$ , follows from Table 12.1 with  $\varepsilon_\lambda = \alpha_\lambda = 1 - \rho_\lambda$  since the sample is diffuse.

$$\varepsilon = E(T_s) / E_b(T_s) = \int_0^\infty \varepsilon_\lambda E_{\lambda,b}(\lambda, 300\text{K}) d\lambda / E_b(300\text{K})$$

$$\varepsilon = (1 - \rho_{\lambda,1}) F_{(0-\lambda_1)} + (1 - \rho_{\lambda,2}) [1 - F_{(0-\lambda_1)}]$$

Using Table 12.1 for  $\lambda_1 T_s = 4 \times 300 = 1200 \mu\text{m}\cdot\text{K}$ ,  $F_{(0-\lambda)} = 0.002$  giving

$$\varepsilon = (1 - 0.2) \times 0.002 + (1 - 0.8) \times (1 - 0.002) = 0.20.$$

(c) Performing an energy balance on the sample, the heat removal rate by the cooling water is

$$q_{\text{cool}} = A_s [\alpha G + q_{\text{conv}}'' - \varepsilon E_b(T_s)]$$

where

$$G = E_b(T_f) = E_b(1000\text{K})$$

$$q_{\text{conv}}'' = h(T_f - T_s) \quad A_s = \pi D^2 / 4$$

$$q_{\text{cool}} = (\pi/4)(0.03\text{m})^2 \left[ 0.49 \times 5.67 \times 10^{-8} \text{W/m}^2 \cdot \text{K}^4 \times (1000\text{K})^4 \right. \\ \left. + 10 \text{W/m}^2 \cdot \text{K} (1000 - 300) \text{K} - 0.20 \times 5.67 \times 10^{-8} \text{W/m}^2 \cdot \text{K}^4 \times (300\text{K})^4 \right] = 24.5 \text{W}. \quad <$$

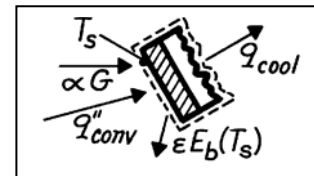

(d) Assume that reflection makes the dominant contribution to the radiosity of the sample. When viewing in the direction A, the spectral radiant power is proportional to  $\rho_\lambda G_\lambda$ . In direction B, the spectral radiant power is proportional to  $E_{\lambda,b}(T_f)$ . Noting that  $G_\lambda = E_{\lambda,b}(T_f)$ , the ratio gives  $\rho_\lambda$ .

### PROBLEM 12.93

**KNOWN:** Small, opaque surface initially at 1200 K with prescribed  $\alpha_\lambda$  distribution placed in a large enclosure at 2400 K.

**FIND:** (a) Total, hemispherical absorptivity of the sample surface, (b) Total, hemispherical emissivity, (c)  $\alpha$  and  $\varepsilon$  after long time has elapsed, (d) Variation of sample temperature with time.

**SCHEMATIC:**

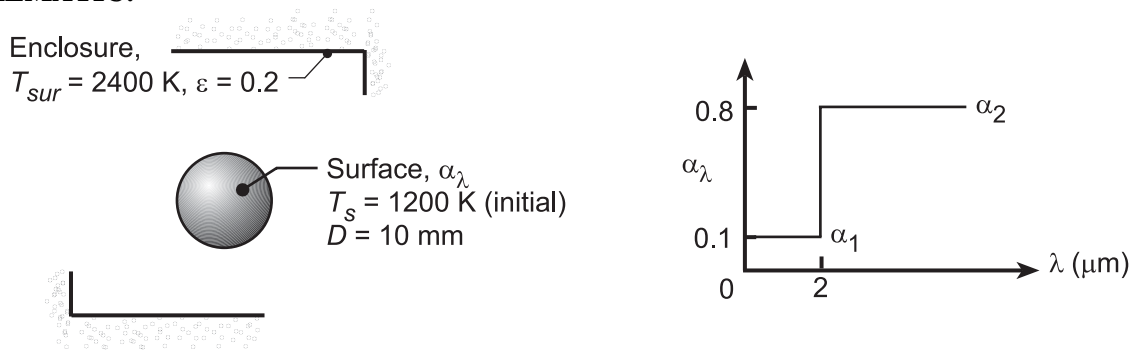

**ASSUMPTIONS:** (1) Surface is diffusely radiated. (2) Enclosure is much larger than surface and at a uniform temperature.

**PROPERTIES:** Table A.1, Tungsten ( $T \approx 1800$  K):  $\rho = 19,300$  kg/m<sup>3</sup>,  $c_p = 163$  J/kg·K,  $k \approx 102$  W/m·K.

**ANALYSIS:** (a) The total, hemispherical absorptivity follows from Eq. 12.52, where  $G_\lambda = E_{\lambda,b}(T_{\text{sur}})$ . That is, the irradiation corresponds to the spectral emissive power of a blackbody at the enclosure temperature and is independent of the enclosure emissivity.

$$\alpha = \int_0^\infty \alpha_\lambda G_\lambda d\lambda / \int_0^\infty G_\lambda d\lambda = \int_0^\infty \alpha_\lambda E_{\lambda,b}(\lambda, T_{\text{sur}}) d\lambda / E_b(T_{\text{sur}})$$

$$\alpha = \alpha_1 \int_0^{2\mu\text{m}} E_{\lambda,b}(\lambda, T_{\text{sur}}) d\lambda / \sigma T_{\text{sur}}^4 + \alpha_2 \int_{2\mu\text{m}}^\infty E_{\lambda,b}(\lambda, T_{\text{sur}}) d\lambda / \sigma T_{\text{sur}}^4$$

$$\alpha = \alpha_1 F_{(0 \rightarrow 2\mu\text{m})} + \alpha_2 [1 - F_{(0 \rightarrow 2\mu\text{m})}] = 0.1 \times 0.6076 + 0.8[1 - 0.6076] = 0.375 \quad <$$

where at  $\lambda T = 2 \times 2400 = 4800 \mu\text{m} \cdot \text{K}$ ,  $F_{(0 \rightarrow 2\mu\text{m})} = 0.6076$  from Table 12.1.

(b) The total, hemispherical emissivity follows from Eq. 12.43,

$$\varepsilon = \int_0^\infty \varepsilon_\lambda E_{\lambda,b}(\lambda, T_s) d\lambda / \int_0^\infty E_{\lambda,b}(\lambda, T_s) d\lambda$$

Since the surface is diffuse,  $\varepsilon_\lambda = \alpha_\lambda$  and the integral can be expressed as

$$\varepsilon = \alpha_1 \int_0^{2\mu\text{m}} E_{\lambda,b}(\lambda, T_s) d\lambda / \sigma T_s^4 + \alpha_2 \int_{2\mu\text{m}}^\infty E_{\lambda,b}(\lambda, T_s) d\lambda / \sigma T_s^4$$

$$\varepsilon = \alpha_1 F_{(0 \rightarrow 2\mu\text{m})} + \alpha_2 [1 - F_{(0 \rightarrow 2\mu\text{m})}] = 0.1 \times 0.1403 + 0.8[1 - 0.1403] = 0.702 \quad <$$

where at  $\lambda T = 2 \times 1200 = 2400 \mu\text{m} \cdot \text{K}$ , find  $F_{(0 \rightarrow 2\mu\text{m})} = 0.1403$  from Table 12.1.

(c) After a long period of time, the surface will be at the temperature of the enclosure. This condition of thermal equilibrium is described by Kirchoff's law, for which

$$\varepsilon = \alpha = 0.375. \quad <$$

Continued...

### PROBLEM 12.93 (Cont.)

(d) Using the IHT *Lumped Capacitance Model*, the energy balance relation is of the form

$$\rho c_p \forall \frac{dT}{dt} = A_s [\alpha G - \varepsilon(T) E_b(T)]$$

where  $T = T_s$ ,  $\forall = \pi D^3/6$ ,  $A_s = \pi D^2$  and  $G = \sigma T_{\text{sur}}^4$ . Integrating over time in increments of  $\Delta t = 0.5\text{s}$  and using the *Radiation Toolpad* to determine  $\varepsilon(t)$ , the following results are obtained.

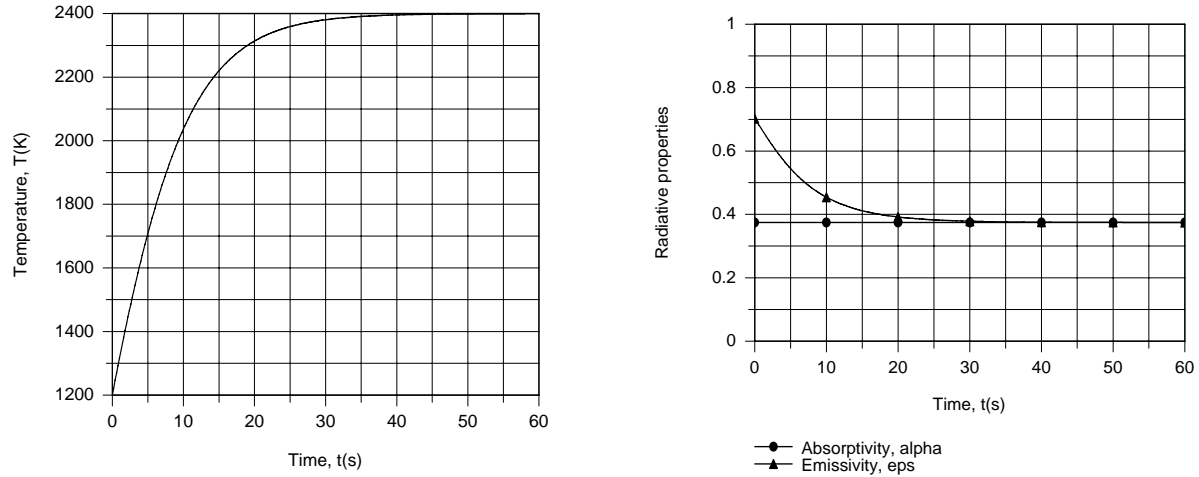

The temperature of the specimen increases rapidly with time and achieves a value of 2399 K within  $t \approx 47\text{s}$ . The emissivity decreases with increasing time, approaching the absorptivity as  $T$  approaches  $T_{\text{sur}}$ .

**COMMENTS:** (1) Recognize that  $\alpha$  always depends upon the spectral irradiation distribution, which, in this case, corresponds to emission from a blackbody at the temperature of the enclosure.

(2) With  $h_r = \varepsilon \sigma (T + T_{\text{sur}})(T^2 + T_{\text{sur}}^2) \approx 0.375 \sigma 4 T_{\text{sur}}^3 = 1176 \text{ W/m}^2 \cdot \text{K}$ ,  $\text{Bi} = h_r (r_o/3)/k = (1176 \text{ W/m}^2 \cdot \text{K}) 1.667 \times 10^{-3} \text{ m}/102 \text{ W/m} \cdot \text{K} = 0.0192 \ll 1$ , use of the lumped capacitance model is justified.



## PROBLEM 12.94

**KNOWN:** Diameter and initial temperature of copper rod. Wall and gas temperature.

**FIND:** (a) Expression for initial rate of change of rod temperature, (b) Initial rate for prescribed conditions, (c) Transient response of rod temperature.

**SCHEMATIC:**

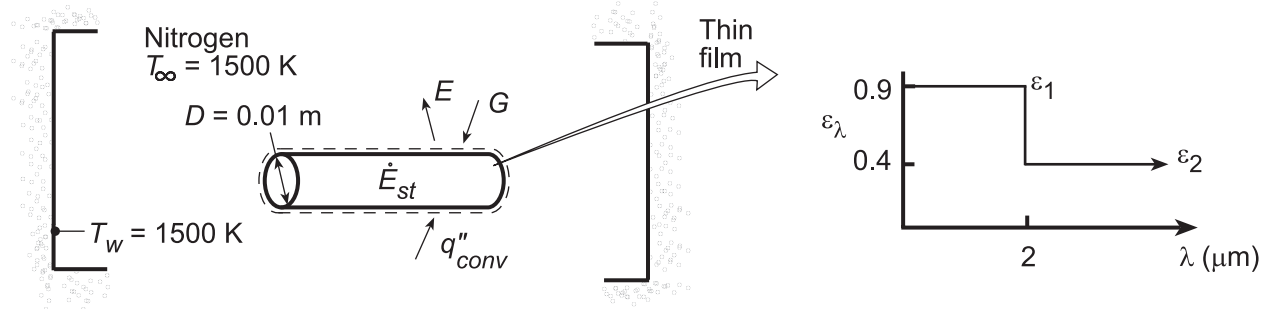

**ASSUMPTIONS:** (1) Applicability of lumped capacitance approximation, (2) Furnace approximates a blackbody cavity, (3) Thin film is diffuse and has negligible thermal resistance, (4) Properties of nitrogen approximate those of air (Part c).

**PROPERTIES:** Table A.1, copper ( $T = 300 \text{ K}$ ):  $c_p = 385 \text{ J/kg}\cdot\text{K}$ ,  $\rho = 8933 \text{ kg/m}^3$ ,  $k = 401 \text{ W/m}\cdot\text{K}$ .  
Table A.4, nitrogen ( $p = 1 \text{ atm}$ ,  $T_f = 900 \text{ K}$ ):  $\nu = 100.3 \times 10^{-6} \text{ m}^2/\text{s}$ ,  $\alpha = 139 \times 10^{-6} \text{ m}^2/\text{s}$ ,  $k = 0.0597 \text{ W/m}\cdot\text{K}$ ,  $\text{Pr} = 0.721$ .

**ANALYSIS:** (a) Applying conservation of energy at an instant of time to a control surface about the cylinder,  $\dot{E}_{\text{in}} - \dot{E}_{\text{out}} = \dot{E}_{\text{st}}$ , where energy inflow is due to natural convection and radiation from the furnace wall and energy outflow is due to emission. Hence, for a unit cylinder length,

$$q_{\text{conv}} + q_{\text{rad,net}} = \frac{\rho \pi D^2}{4} c_p \frac{dT}{dt}$$

where

$$q_{\text{conv}} = \bar{h}(\pi D)(T_\infty - T)$$

$$q_{\text{rad,net}} = \pi D(\alpha G - \varepsilon E_b) = \pi D[\alpha E_b(T_w) - \varepsilon E_b(T)]$$

Hence, at  $t = 0$  ( $T = T_i$ ),

$$dT/dt|_i = (4/\rho c_p D) [\bar{h}(T_\infty - T_i) + \alpha E_b(T_w) - \varepsilon E_b(T_i)]$$

(b) With  $\text{Ra}_D = \frac{g\beta(T_\infty - T_i)D^3}{\alpha\nu} = \frac{9.8 \text{ m/s}^2 (1/900 \text{ K})(1200 \text{ K})(0.01 \text{ m})^3}{100.3 \times 139 \times 10^{-12} \text{ m}^4/\text{s}^2} = 937$ , the Churchill-Chu

correlation of Chapter 9 yields

$$\bar{\text{Nu}}_D = \left\{ 0.60 + \frac{0.387 \text{Ra}_D^{1/6}}{\left[ 1 + (0.559/\text{Pr})^{9/16} \right]^{8/27}} \right\}^2 = 2.58$$

$$\bar{h} = k \frac{\bar{\text{Nu}}_D}{D} = \frac{(0.0597 \text{ W/m}\cdot\text{K}) 2.58}{0.01 \text{ m}} = 15.4 \text{ W/m}^2\cdot\text{K}$$

With  $T = T_i = 300 \text{ K}$ ,  $\lambda T = 600 \mu\text{m}\cdot\text{K}$  yields  $F_{(0 \rightarrow \lambda)} = 0$ , in which case  $\varepsilon = \varepsilon_1 F_{(0 \rightarrow \lambda)} + \varepsilon_2 [1 - F_{(0 \rightarrow \lambda)}] = 0.4$ .

With  $T = T_w = 1500 \text{ K}$ ,  $\lambda T = 3000 \text{ K}$  yields  $F_{(0 \rightarrow \lambda)} = 0.273$ . Hence, with  $\alpha_\lambda = \varepsilon_\lambda$ ,  $\alpha = \varepsilon_1 F_{(0 \rightarrow \lambda)} + \varepsilon_2 [1 - F_{(0 \rightarrow \lambda)}] = 0.9(0.273) + 0.4(1 - 0.273) = 0.537$ . It follows that

Continued...

**PROBLEM 12.94 (Cont.)**

$$\left. \frac{dT}{dt} \right|_i = \frac{4}{8933 \frac{\text{kg}}{\text{m}^3} \left( 385 \frac{\text{J}}{\text{kg} \cdot \text{K}} \right) 0.01 \text{m}} \left[ 15.4 \frac{\text{W}}{\text{m}^2 \cdot \text{K}} (1500 - 300) \text{K} \right. \\ \left. + 0.537 \times 5.67 \times 10^{-4} \frac{\text{W}}{\text{m}^2 \cdot \text{K}^4} (1500 \text{K})^4 - 0.4 \times 5.67 \times 10^{-8} \frac{\text{W}}{\text{m}^2 \cdot \text{K}^4} (300 \text{K})^4 \right]$$

$$dT/dt)_i = 1.163 \times 10^{-4} \text{m}^2 \cdot \text{K}/\text{J} [18,480 + 154,140 - 180] \text{W}/\text{m}^2 = 20 \text{K/s} \quad <$$

Defining a pseudo radiation coefficient as  $h_r = (\alpha G - \epsilon E_b)/(T_w - T_i) = (153,960 \text{ W/m}^2)/1200 \text{ K} = 128.3 \text{ W/m}^2 \cdot \text{K}$ ,  $Bi = (h + h_r)(D/4)/k = 143.7 \text{ W/m}^2 \cdot \text{K} (0.0025 \text{ m})/401 \text{ W/m} \cdot \text{K} = 0.0009$ . Hence, the lumped capacitance approximation is appropriate.

(c) Using the IHT *Lumped Capacitance Model with the Correlations, Radiation and Properties* (copper and air) Toolpads, the transient response of the rod was computed for  $300 \leq T < 1200 \text{ K}$ , where the upper limit was determined by the temperature range of the copper property table.

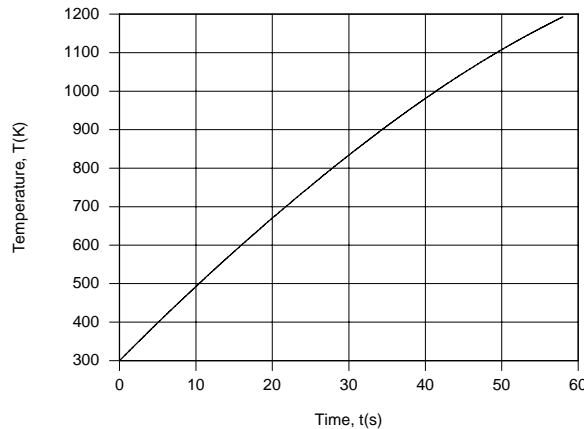

The rate of change of the rod temperature,  $dT/dt$ , decreases with increasing temperature, in accordance with a reduction in the convective and *net* radiative heating rates. Note, however, that even at  $T \approx 1200 \text{ K}$ ,  $\alpha G$ , which is fixed, is large relative to  $q''_{\text{conv}}$  and  $\epsilon E_b$  and  $dT/dt$  is still significant.

## PROBLEM 12.95

**KNOWN:** Temperatures of furnace wall and top and bottom surfaces of a planar sample. Dimensions and emissivity of sample.

**FIND:** (a) Sample thermal conductivity, (b) Validity of assuming uniform bottom surface temperature.

**SCHEMATIC:**

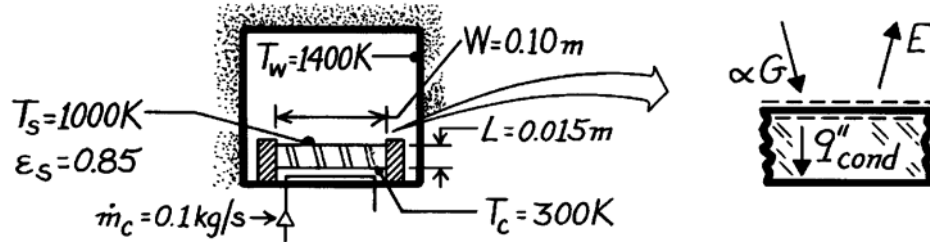

**ASSUMPTIONS:** (1) Steady-state conditions, (2) One-dimensional conduction in sample, (3) Constant  $k$ , (4) Diffuse-gray surface, (5) Irradiation equal to blackbody emission at 1400K.

**PROPERTIES:** Table A-6, Water coolant (300K):  $c_{p,c} = 4179 \text{ J/kg}\cdot\text{K}$

**ANALYSIS:** (a) From energy balance at top surface,

$$\alpha G - E = q''_{\text{cond}} = k_s (T_s - T_c) / L$$

where  $E = \varepsilon_s \sigma T_s^4$ ,  $G = \sigma T_w^4$ ,  $\alpha = \varepsilon_s$  giving

$$\varepsilon_s \sigma T_w^4 - \varepsilon_s \sigma T_s^4 = k_s (T_s - T_c) / L.$$

Solving for the thermal conductivity and substituting numerical values, find

$$k_s = \frac{\varepsilon_s L \sigma}{T_s - T_c} (T_w^4 - T_s^4)$$

$$k_s = \frac{0.85 \times 0.015 \text{ m} \times 5.67 \times 10^{-8} \text{ W/m}^2 \cdot \text{K}^4}{(1000 - 300) \text{ K}} \left[ (1400 \text{ K})^4 - (1000 \text{ K})^4 \right]$$

$$k_s = 2.93 \text{ W/m}\cdot\text{K}. \quad <$$

(b) Non-uniformity of bottom surface temperature depends on coolant temperature rise. From the energy balance

$$q = \dot{m}_c c_{p,c} \Delta T_c = (\alpha G - E) W^2$$

$$\Delta T_c = \frac{0.85 \times 5.67 \times 10^{-8} \text{ W/m}^2 \cdot \text{K}^4 \left[ 1400^4 - 1000^4 \right] \text{ K}^4 (0.10 \text{ m})^2}{0.1 \text{ kg/s} \times 4179 \text{ J/kg}\cdot\text{K}}$$

$$\Delta T_c = 3.3 \text{ K}. \quad <$$

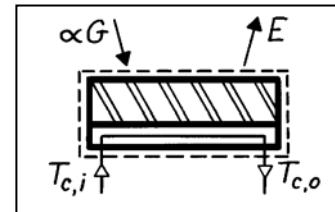

The variation in  $T_c$  ( $\sim 3\text{K}$ ) is small compared to  $(T_s - T_c) \approx 700\text{K}$ . Hence it is not large enough to introduce significant error in the  $k$  determination.

## PROBLEM 12.96

**KNOWN:** Thicknesses and thermal conductivities of a ceramic/metal composite. Emissivity of ceramic surface. Temperatures of vacuum chamber wall and substrate lower surface. Receiving area of radiation detector, distance of detector from sample, and sample surface area viewed by detector.

**FIND:** (a) Ceramic top surface temperature and heat flux, (b) Rate at which radiation emitted by the ceramic is intercepted by detector, (c) Effect of an interfacial (ceramic/substrate) contact resistance on sample top and bottom surface temperatures.

**SCHEMATIC:**

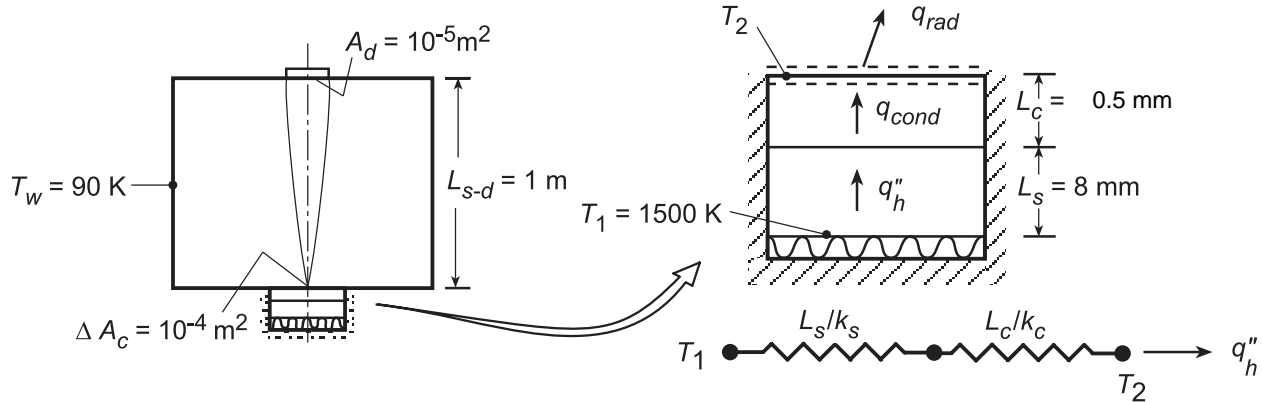

**ASSUMPTIONS:** (1) One-dimensional, steady-state conduction in sample, (2) Constant properties, (3) Chamber forms a blackbody enclosure at  $T_w$ , (4) Ceramic surface is diffuse/gray, (5) Negligible interface contact resistance for part (a).

**PROPERTIES:** Ceramic:  $k_c = 6 \text{ W/m}\cdot\text{K}$ ,  $\epsilon_c = 0.8$ . Substrate:  $k_s = 25 \text{ W/m}\cdot\text{K}$ .

**ANALYSIS:** (a) From an energy balance at the exposed ceramic surface,  $q''_{\text{cond}} = q''_{\text{rad}}$ , or

$$\frac{T_1 - T_2}{(L_s/k_s) + (L_c/k_c)} = \epsilon_c \sigma (T_2^4 - T_w^4)$$

$$\frac{1500 \text{ K} - T_2}{\frac{0.008 \text{ m}}{25 \text{ W/m}\cdot\text{K}} + \frac{0.0005 \text{ m}}{6 \text{ W/m}\cdot\text{K}}} = 0.8 \times 5.67 \times 10^{-8} \text{ W/m}^2 \cdot \text{K}^4 (T_2^4 - 90^4) \text{ K}^4$$

$$3.72 \times 10^6 - 2479 T_2 = 4.54 \times 10^{-8} T_2^4 - 2.98$$

$$4.54 \times 10^{-8} T_2^4 + 2479 T_2 = 3.72 \times 10^6$$

Solving, we obtain

$$T_2 = 1425 \text{ K} \quad \angle$$

$$q''_h = \frac{T_1 - T_2}{(L_s/k_s) + (L_c/k_c)} = \frac{(1500 - 1425) \text{ K}}{4.033 \times 10^{-4} \text{ m}^2 \cdot \text{K/W}} = 1.87 \times 10^5 \text{ W/m}^2 \quad \angle$$

(b) Since the ceramic surface is diffuse, the total intensity of radiation emitted in all directions is  $I_e = \epsilon_c E_b(T_s)/\pi$ . Hence, the rate at which emitted radiation is intercepted by the detector is

$$q_{c(\text{em})-d} = I_e \Delta A_c \left( A_d / L_{s-d}^2 \right)$$

$$q_{c(\text{em})-d} = \frac{0.8 \times 5.67 \times 10^{-8} \text{ W/m}^2 \cdot \text{K}^4 (1425 \text{ K})^4}{\pi \text{ sr}} \times 10^{-4} \text{ m}^2 \times 10^{-5} \text{ sr} = 5.95 \times 10^{-5} \text{ W}$$

Continued...

### PROBLEM 12.96 (Cont.)

(c) With the development of an interfacial thermal contact resistance and fixed values of  $q_h''$  and  $T_w$ , (i)  $T_2$  remains the same (its value is determined by the requirement that  $q_h'' = \varepsilon_c \sigma (T_2^4 - T_w^4)$ ), while (ii)  $T_1$  increases (its value is determined by the requirement that  $q_h'' = (T_1 - T_2)/R_{\text{tot}}''$ , where  $R_{\text{tot}}'' = [(L_s/k_s) + R_{t,c}'' + (L_c/k_c)]$ ); if  $q_h''$  and  $T_2$  are fixed,  $T_1$  must increase with increasing  $R_{\text{tot}}''$ .

**COMMENTS:** The detector will also see radiation which is reflected from the ceramic. The corresponding radiation rate is  $q_{c(\text{reflection})-d} = \rho_c G_c \Delta A_c A_d / L_{s-d}^2 = 0.2 \sigma (90 \text{ K})^4 \times 10^{-4} \text{ m}^2 \times (10^{-5} \text{ sr}) = 7.44 \times 10^{-10} \text{ W}$ . Hence, reflection is negligible.

## PROBLEM 12.97

**KNOWN:** Wafer heated by ion beam source within large process-gas chamber with walls at uniform temperature; radiometer views a  $5 \times 5$  mm target on the wafer. Black panel mounted in place of wafer in a pre-production test of the equipment.

**FIND:** (a) Radiant power ( $\mu\text{W}$ ) received by the radiometer when the black panel temperature is  $T_{\text{bp}} = 800$  K and (b) Temperature of the wafer,  $T_{\text{w}}$ , when the ion beam source is adjusted so that the radiant power received by the radiometer is the same as that of part (a)

**SCHEMATIC:**

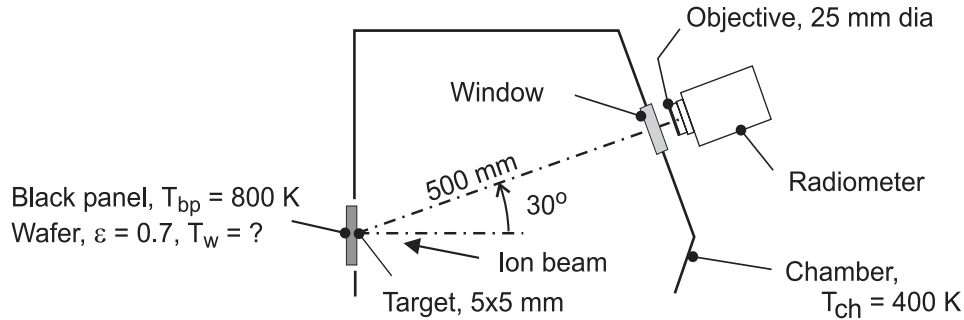

**ASSUMPTIONS:** (1) Steady-state conditions, (2) Chamber represents large, isothermal surroundings, (3) Wafer is opaque, diffuse-gray, and (4) Target area  $\ll$  square of distance between target and radiometer objective.

**ANALYSIS:** (a) The radiant power leaving the black-panel target and reaching the radiometer as illustrated in the schematic below is

$$q_{\text{bp-rad}} = \left[ E_{\text{b, bp}}(T_{\text{bp}}) / \pi \right] A_{\text{t}} \cos \theta_{\text{t}} \cdot \Delta \omega_{\text{rad-t}} \quad (1)$$

where  $\theta_{\text{t}} = 0^\circ$  and the solid angle the radiometer subtends with respect to the target follows from Eq. 12.7,

$$\Delta \omega_{\text{rad-t}} = \frac{dA_{\text{n}}}{r^2} = \frac{(\pi D_{\text{o}}^2 / 4)}{r^2} = \frac{\pi (0.025 \text{ m})^2 / 4}{(0.500 \text{ m})^2} = 1.964 \times 10^{-3} \text{ sr}$$

With  $E_{\text{b, bp}} = \sigma T_{\text{bp}}^4$ , find

$$q_{\text{bp-rad}} = \left[ 5.67 \times 10^{-8} \text{ W/m}^2 \cdot \text{K}^4 (800 \text{ K})^4 / \pi \text{ sr} \right] \\ \times (0.005 \text{ m})^2 \times \cos 30^\circ \times 1.964 \times 10^{-3} \text{ sr}$$

$$q_{\text{bp-rad}} = 314 \mu\text{W}$$

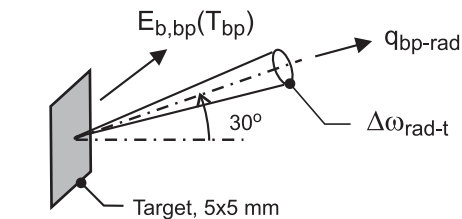

(a) Black panel,  $T_{\text{bp}} = 800$  K

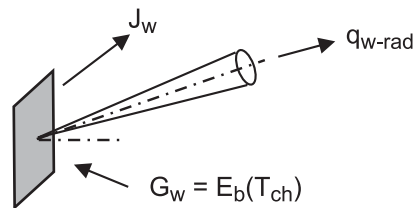

(b) Wafer,  $\epsilon_{\text{w}} = 0.7$ ,  $T_{\text{w}} = ?$

Continued ...

### PROBLEM 12.97 (Cont.)

(b) With the wafer mounted, the ion beam source is adjusted until the radiometer receives the same radiant power as with part (a) for the black panel. The power reaching the radiometer is expressed in terms of the wafer radiosity,

$$q_{w-\text{rad}} = [J_w / \pi] A_t \cos \theta_t \cdot \Delta \omega_{\text{rad-t}} \quad (2)$$

Since  $q_{w-\text{rad}} = q_{\text{bp-rad}}$  (see Eq. (1)), recognize that

$$J_w = E_{\text{b, bp}}(T_{\text{bp}}) \quad (3)$$

where the radiosity is

$$J_w = \varepsilon_w E_{\text{b,w}}(T_w) + \rho_w G_w = \varepsilon_w E_{\text{b,w}}(T_w) + (1 - \varepsilon_w) E_{\text{b}}(T_{\text{ch}}) \quad (4)$$

and  $G_w$  is equal to the blackbody emissive power at  $T_{\text{ch}}$ . Using Eqs. (3) and (4) and substituting numerical values, find

$$\sigma T_{\text{bp}}^4 = \varepsilon_w \sigma T_w^4 + (1 - \varepsilon_w) \sigma T_{\text{ch}}^4$$

$$(800 \text{ K})^4 = 0.7 T_w^4 + 0.3(400 \text{ K})^4$$

$$T_w = 871 \text{ K} \quad <$$

**COMMENTS:** (1) Explain why  $T_w$  is higher than 800 K, the temperature of the black panel, when the radiometer receives the same radiant power for both situations.

(2) If the chamber walls were cold relative to the wafer, say near liquid nitrogen temperature,  $T_{\text{ch}} = 80 \text{ K}$ , and the test repeated with the same indicated radiometer power, is the wafer temperature higher or lower than 871 K?

(3) If the chamber walls were maintained at 800 K, and the test repeated with the same indicated radiometer power, what is the wafer temperature?

## PROBLEM 12.98

**KNOWN:** Spectral emissivity of fire brick wall used to construct brick oven. Magnitude and distribution of irradiation on wall. Temperature and heat transfer coefficient of gases adjacent to wall. Wall thickness and thermal conductivity.

**FIND:** Wall interior surface temperature if heat loss through wall is negligible. Wall interior surface temperature if wall is insulated and exterior surface temperature of insulation is 300 K.

**SCHEMATIC:**

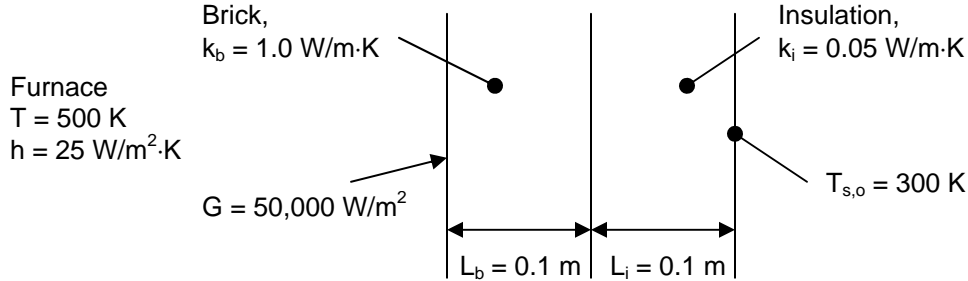

**ASSUMPTIONS:** (1) Brick wall is opaque and diffuse, (2) Spectral distribution of irradiation reaching brick wall approximates that due to emission from a blackbody at 2000 K.

**PROPERTIES:** Fire brick wall (given in Example 12.10):  $\varepsilon_\lambda \approx 0.1$ ,  $\lambda < 1.5 \mu\text{m}$ ,  $\varepsilon_\lambda \approx 0.5$ ,  $1.5 \mu\text{m} \leq \lambda < 10 \mu\text{m}$ ,  $\varepsilon_\lambda \approx 0.8$ ,  $\lambda \geq 10 \mu\text{m}$ ;  $\alpha = 0.395$  (for irradiation with spectral distribution proportional to blackbody at 2000 K).

**ANALYSIS:** Neglecting heat transfer through the wall, an energy balance on the wall can be written,

$$\begin{aligned} \dot{E}_{\text{in}} - \dot{E}_{\text{out}} &= \alpha G - E - q''_{\text{conv}} = 0 \\ \alpha G - E(T_s) - h(T_s - T_\infty) &= 0 \end{aligned} \quad (1)$$

From Example 12.10, we know that the absorptivity to irradiation having the spectral distribution of a blackbody at 2000 K is  $\alpha = 0.395$ . Now we must find the emissive power of the wall from Table 12.1 and Eq. 12.43,

$$E(T_s) = \varepsilon(T_s)E_b(T_s) = \int_0^\infty \varepsilon_\lambda(\lambda)E_{\lambda,b}(\lambda, T_s)d\lambda = I_1 + I_2 + I_3$$

where

$$I_1 = 0.1 \int_0^{1.5 \mu\text{m}} E_{\lambda,b}(\lambda, T_s)d\lambda = 0.1F_{(0 \rightarrow 1.5 \mu\text{m})}E_b(T_s)$$

$$I_2 = 0.5 \int_{1.5 \mu\text{m}}^{10 \mu\text{m}} E_{\lambda,b}(\lambda, T_s)d\lambda = 0.5F_{(1.5 \mu\text{m} \rightarrow 10 \mu\text{m})}E_b(T_s)$$

$$I_3 = 0.8 \int_{10 \mu\text{m}}^\infty E_{\lambda,b}(\lambda, T_s)d\lambda = 0.8F_{(10 \mu\text{m} \rightarrow \infty)}E_b(T_s)$$

Continued...



### PROBLEM 12.98 (Cont.)

Thus,

$$E(T_s) = \left[ 0.1F_{(0 \rightarrow 1.5\mu\text{m})} + 0.5(F_{(0 \rightarrow 10\mu\text{m})} - F_{(0 \rightarrow 1.5\mu\text{m})}) + 0.8(1 - F_{(0 \rightarrow 10\mu\text{m})}) \right] E_b(T_s) \quad (2)$$

Eqs. (1) and (2) are two equations in the two unknowns,  $T_s$  and  $E(T_s)$ , where each of the  $F$ 's also depends on  $T_s$  (from Table 12.1). A numerical solution is required. An *IHT* code to solve this problem is shown in the Comments section. The solution is

$$T_s = 796 \text{ K} \quad <$$

With conduction through the wall, the energy balance becomes

$$\begin{aligned} \dot{E}_{\text{in}} - \dot{E}_{\text{out}} &= \alpha G - E - q_{\text{conv}}'' - q_{\text{cond}}'' = 0 \\ \alpha G - E(T_s) - h(T_s - T_{\infty}) - (T_s - T_{s,o})/R_{\text{tot}}'' &= 0 \end{aligned} \quad (3)$$

where

$$R_{\text{tot}}'' = L_b/k_b + L_i/k_i = 0.1 \text{ m}/1.0 \text{ W/m}\cdot\text{K} + 0.1 \text{ m}/0.05 \text{ W/m}\cdot\text{K} = 2.1 \text{ m}^2 \cdot \text{K}/\text{W}$$

Eqs. (2) and (3) can once again be solved using *IHT*, to find

$$T_s = 793 \text{ K} \quad <$$

**COMMENTS:** (1) If the conduction heat flux is included, the surface temperature drops by only 3 K. (2) The *IHT* code to solve the problem is shown below. Note that if Eq. (1) or (3) is used directly, the code does not converge to a solution for  $T_s$ . Instead, the code is set up to calculate a variable “qnet” that is the net heat flux at the surface, and  $T_s$  is varied until qnet is approximately zero.

```
//Energy balance on inner surface
/* To effect convergence, calculate qnet as a function of Ts, and "Explore" Ts to find value for which qnet = 0. */
qnet = alpha*G - E - h*(Ts - Tinf) - qcond
Ts = 500

//Calculate qcond. Select from two options below.
qcond = (Ts - Tso)/Rtot
//qcond = 0

//Calculate E(Ts).
lambda1 = 1.5
lambda2 = 10
/* The blackbody band emission factor, Figure 12.14 and Table 12.1, is */
FLT1 = F_lambda_T(lambda1,Ts) // Eq 12.34
FLT2 = F_lambda_T(lambda2,Ts) // Eq 12.34
// where units are lambda (micrometers, mum) and T (K)
E = (0.1*FLT1 + 0.5*(FLT2 - FLT1) + 0.8*(1-FLT2))*Eb
Eb = sigma*Ts^4
sigma = 5.67e-8

//Inputs
alpha = 0.395
G = 50000
h = 25
Tinf = 500
Tso = 300
Rtot = 0.1/1.0 + 0.1/0.05
```

## PROBLEM 12.99

**KNOWN:** Laser-materials-processing apparatus. Spectrally selective sample heated to the operating temperature  $T_s = 2000$  K by laser irradiation ( $0.5 \mu\text{m}$ ),  $G_{\text{laser}}$ , experiences convection with an inert gas and radiation exchange with the enclosure.

**FIND:** (a) Total emissivity of the sample,  $\epsilon$ ; (b) Total absorptivity of the sample,  $\alpha$ , for irradiation from the enclosure; (c) Laser irradiation required to maintain the sample at  $T_s = 2000$  K by performing an energy balance on the sample; (d) Sketch of the sample emissivity during the cool-down process when the laser and inert gas flow are deactivated; identify key features including the emissivity for the final condition ( $t \rightarrow \infty$ ); and (e) Time-to-cool the sample from the operating condition at  $T_s(0) = 2000$  K to a safe-to-touch temperature of  $T_s(t) = 40^\circ\text{C}$ ; use the lumped capacitance method and include the effects of convection with inert gas ( $T_\infty = 300$  K,  $h = 50$  W/m<sup>2</sup>·K) as well as radiation exchange  $T_{\text{enc}} = T_\infty$ .

**SCHEMATIC:**

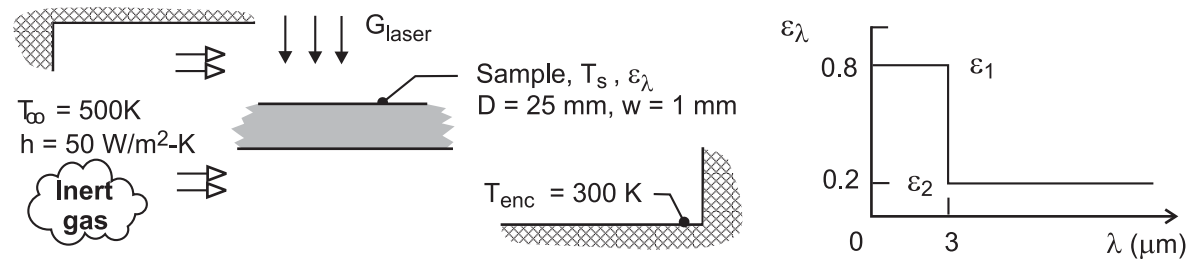

**ASSUMPTIONS:** (1) Enclosure is isothermal and large compared to the sample, (2) Sample is opaque and diffuse, but spectrally selective, so that  $\epsilon_\lambda = \alpha_\lambda$ , (3) Sample is isothermal.

**PROPERTIES:** Sample (Given)  $\rho = 3900$  kg/m<sup>3</sup>,  $c_p = 760$  J/kg,  $k = 45$  W/m·K.

**ANALYSIS:** (a) The total emissivity of the sample,  $\epsilon$ , at  $T_s = 2000$  K follows from Eq. 12.43 which can be expressed in terms of the band emission factor,  $F_{(0-\lambda_1 T)}$  Eq. 12.34,

$$\epsilon = \epsilon_1 F_{(0-\lambda_1 T_s)} + \epsilon_2 [1 - F_{(0-\lambda_1 T_s)}] \quad (1)$$

$$\epsilon = 0.8 \times 0.7378 + 0.2 [1 - 0.7378] = 0.643 \quad <$$

where from Table 12.1, with  $\lambda_1 T_s = 3 \mu\text{m} \times 2000$  K = 6000  $\mu\text{m} \cdot \text{K}$ ,  $F_{(0-\lambda_1 T)} = 0.7378$ .

(b) The total absorptivity of the sample,  $\alpha$ , for irradiation from the enclosure at  $T_{\text{enc}} = 300$  K, is

$$\alpha = \epsilon_1 F_{(0-\lambda_1 T_{\text{enc}})} + \epsilon_2 [1 - F_{(0-\lambda_1 T_{\text{enc}})}] \quad (2)$$

$$\alpha = 0.8 \times 0 + 0.2 [1 - 0] = 0.200 \quad <$$

where, from Table 12.1, with  $\lambda_1 T_{\text{enc}} = 3 \mu\text{m} \times 300$  K = 900  $\mu\text{m} \cdot \text{K}$ ,  $F_{(0-\lambda_1 T)} = 0$ .

Continued...

### PROBLEM 12.99 (Cont.)

(c) The energy balance on the sample, on a per unit area basis, as shown in the schematic at the right is

$$\dot{E}_{in} - \dot{E}_{out} = 0$$

$$+\alpha_{las}G_{laser} + 2\alpha G - 2\varepsilon E_b(T_s) - q''_{cv} = 0$$

$$\alpha_{las}G_{laser} + 2\alpha\sigma T_{enc}^4 - 2\varepsilon\sigma T_s^4 - 2h(T_s - T_\infty) = 0 \quad (3)$$

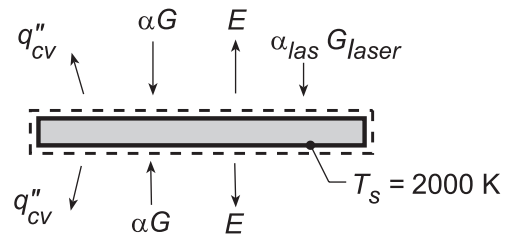

Recognizing that  $\alpha_{las}(0.5 \mu\text{m}) = 0.8$ , and substituting numerical values find,

$$0.8 \times G_{laser} + 2 \times 0.200 \times 5.67 \times 10^{-8} \text{ W/m}^2 \cdot \text{K}^4 (300 \text{ K})^4$$

$$- 2 \times 0.643 \times 5.67 \times 10^{-8} \text{ W/m}^2 \cdot \text{K}^4 (2000 \text{ K})^4 - 2 \times 50 \text{ W/m}^2 \cdot \text{K} (2000 - 500) \text{ K} = 0$$

$$0.8 \times G_{laser} = \left[ -184.6 + 1.167 \times 10^6 + 1.500 \times 10^5 \right] \text{ W/m}^2$$

$$G_{laser} = 1646 \text{ kW/m}^2$$

(d) During the cool-down process, the total emissivity  $\varepsilon$  will decrease as the temperature decreases,  $T_s(t)$ . In the limit,  $t \rightarrow \infty$ , the sample will reach that of the enclosure,  $T_s(\infty) = T_{enc}$  for which  $\varepsilon = \alpha = 0.200$ .

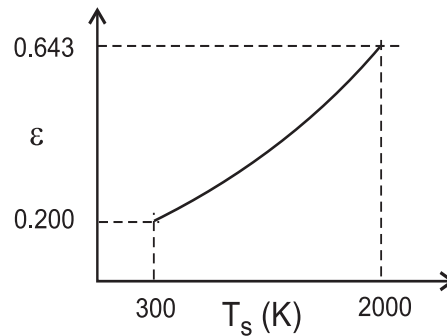

(e) Using the *IHT Lumped Capacitance Model* considering radiation exchange ( $T_{enc} = 300 \text{ K}$ ) and convection ( $T_\infty = 300 \text{ K}$ ,  $h = 50 \text{ W/m}^2 \cdot \text{K}$ ) and evaluating the emissivity using Eq. (1) with the *Radiation Tool, Band Emission Factors*, the temperature-time history was determined and the time-to-cool to  $T(t) = 40^\circ\text{C}$  was found as

$$t = 119 \text{ s}$$

**COMMENTS:** (1) From the IHT model used for part (e), the emissivity as a function of cooling time and sample temperature were computed and are plotted below. Compare these results to your sketch of part (c).

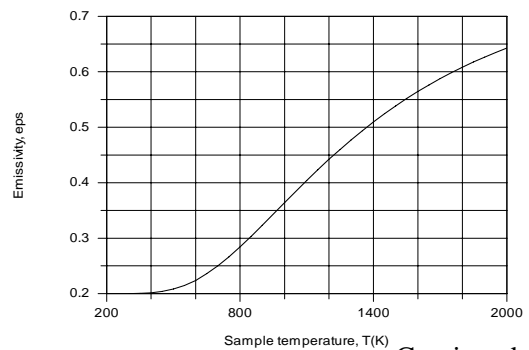
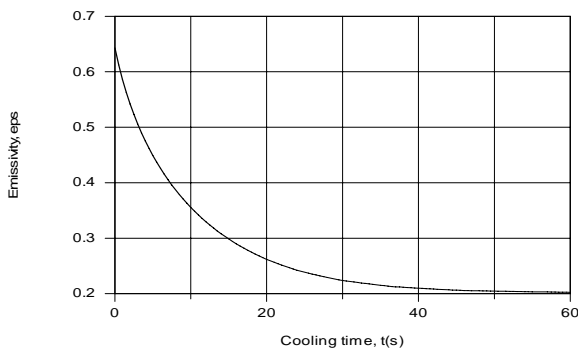

Continued...

## PROBLEM 12.99 (Cont.)

(2) The IHT workspace model to perform the lumped capacitance analysis with variable emissivity is shown below.

### // Lumped Capacitance Model - convection and emission/irradiation radiation processes:

```
/* Conservation of energy requirement on the control volume, CV. */
Edotin - Edotout = Edotst
Edotin = As * ( + Gabs)
Edotout = As * ( + q"cv + E )
Edotst = rho * vol * cp * Der(T,t)
T_C = T - 273
// Absorbed irradiation from large surroundings on CS
Gabs = alpha * G
G = sigma * Tsur^4
sigma = 5.67e-8 // Stefan-Boltzmann constant, W/m^2-K^4
// Emissive power of CS
E = eps * Eb
Eb = sigma * T^4
//sigma = 5.67e-8 // Stefan-Boltzmann constant, W/m^2-K^4
//Convection heat flux for control surface CS
q"cv = h * ( T - Tinf )
/* The independent variables for this system and their assigned numerical values are */
As = 2 * 1 // surface area, m^2; unit area, top and bottom surfaces
vol = 1 * w // vol, m^3
w = 0.001 // sample thickness, m
rho = 3900 // density, kg/m^3
cp = 760 // specific heat, J/kg-K
// Convection heat flux, CS
h = 50 // convection coefficient, W/m^2-K
Tinf = 300 // fluid temperature, K
// Emission, CS
//eps = 0.5 // emissivity; value used to test the model initially
// Irradiation from large surroundings, CS
alpha = 0.200 // absorptivity; from Part (b); remains constant during cool-down
Tsur = 300 // surroundings temperature, K
```

### // Radiation Tool - Band emission factor:

```
eps = eps1 * FL1T + eps2 * ( 1 - FL1T )
/* The blackbody band emission factor, Figure 12.12 and Table 12.1, is */
FL1T = F_lambda_T(lambda1,T) // Eq 12.34
// where units are lambda (micrometers, mum) and T (K)
lambda1 = 3 // wavelength, mum
eps1 = 0.8 // spectral emissivity; for lambda < lambda1
eps2 = 0.2 // spectral emissivity; for lambda > lambda1
```

## PROBLEM 12.100

**KNOWN:** Cross flow of air over a cylinder placed within a large furnace.

**FIND:** (a) Steady-state temperature of the cylinder when it is diffuse and gray with  $\varepsilon = 0.5$ , (b) Steady-state temperature when surface has spectral properties shown below, (c) Steady-state temperature of the diffuse, gray cylinder if air flow is parallel to the cylindrical axis, (d) Effect of air velocity on cylinder temperature for conditions of part (a).

**SCHEMATIC:**

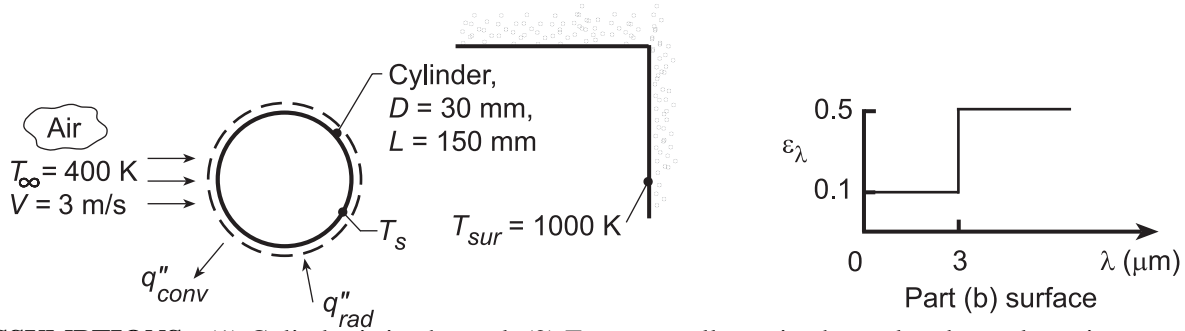

**ASSUMPTIONS:** (1) Cylinder is isothermal, (2) Furnace walls are isothermal and very large in area compared to the cylinder, (3) Steady-state conditions.

**PROPERTIES:** Table A.4, Air ( $T_f \approx 600$  K):  $\nu = 52.69 \times 10^{-6} \text{ m}^2/\text{s}$ ,  $k = 46.9 \times 10^{-3} \text{ W/m}\cdot\text{K}$ ,  $\text{Pr} = 0.685$ .

**ANALYSIS:** (a) When the cylinder surface is gray and diffuse with  $\varepsilon = 0.5$ , the energy balance is of the form,  $q''_{\text{rad}} - q''_{\text{conv}} = 0$ . Hence,

$$\varepsilon \sigma (T_{\text{sur}}^4 - T_s^4) - \bar{h} (T_s - T_{\infty}) = 0.$$

The heat transfer coefficient,  $\bar{h}$ , can be estimated from the Churchill-Bernstein correlation of Chapter 7,

$$\overline{\text{Nu}}_D = (\bar{h} D/k) = 0.3 + \frac{0.62 \text{Re}_D^{1/2} \text{Pr}^{1/3}}{\left[1 + (0.4/\text{Pr})^{2/3}\right]^{1/4}} \left[1 + \left(\frac{\text{Re}_D}{282,000}\right)^{5/8}\right]^{4/5}$$

where  $\text{Re}_D = VD/\nu = 3 \text{ m/s} \times 30 \times 10^{-3} \text{ m} / 52.69 \times 10^{-6} \text{ m}^2/\text{s} = 1710$ . Hence,

$$\overline{\text{Nu}}_D = 20.8$$

$$\bar{h} = 20.8 \times 46.9 \times 10^{-3} \text{ W/m}\cdot\text{K} / 30 \times 10^{-3} \text{ m} = 32.5 \text{ W/m}^2\cdot\text{K}.$$

Using this value of  $\bar{h}$  in the energy balance expression, we obtain

$$0.5 \times 5.67 \times 10^{-8} (1000^4 - T_s^4) \text{ W/m}^2 - 32.5 \text{ W/m}^2\cdot\text{K} (T_s - 400) \text{ K} = 0$$

which yields  $T_s \approx 839$  K. <

(b) When the cylinder has the spectrally selective behavior, the energy balance is written as

$$\alpha G - \varepsilon E_b(T_s) - q''_{\text{conv}} = 0$$

where  $G = E_b(T_{\text{sur}})$ . With  $\alpha = \int_0^{\infty} \alpha_{\lambda} G_{\lambda} d\lambda / G$ ,

$$\alpha = 0.1 \times F_{(0 \rightarrow 3 \mu\text{m})} + 0.5 \times (1 - F_{(0 \rightarrow 3 \mu\text{m})}) = 0.1 \times 0.273 + 0.5(1 - 0.273) = 0.391$$

where, using Table 12.1 with  $\lambda T = 3 \times 1000 = 3000 \mu\text{m}\cdot\text{K}$ ,  $F_{(0 \rightarrow 3)} = 0.273$ . Assuming  $T_s$  is such that emission in the spectral region  $\lambda < 3 \mu\text{m}$  is negligible, the energy balance becomes

Continued...

### PROBLEM 12.100 (Cont.)

$$0.391 \times 5.67 \times 10^{-8} \times 1000^4 \text{ W/m}^2 - 0.5 \times 5.67 \times 10^{-8} \times T_s^4 \text{ W/m}^2 - 32.5 \text{ W/m}^2 \cdot \text{K} (T_s - 400) \text{ K} = 0$$

which yields  $T_s \approx 770 \text{ K}$ . <

Note that, for  $\lambda T = 3 \times 770 = 2310 \text{ } \mu\text{m}\cdot\text{K}$ ,  $F_{(0 \rightarrow \lambda)} \approx 0.11$ ; hence the assumption of  $\varepsilon = 0.5$  is acceptable.

Note that the value of  $\bar{h}$  based upon  $T_f = 600 \text{ K}$  is also acceptable.

(c) When the cylinder is diffuse-gray with air flow in the longitudinal direction, the characteristic length for convection is different. Assume conditions can be modeled as flow over a flat plate of  $L = 150 \text{ mm}$ .  
With

$$\text{Re}_L = VL/\nu = 3 \text{ m/s} \times 150 \times 10^{-3} \text{ m} / 52.69 \times 10^{-6} \text{ m}^2/\text{s} = 8540$$

$$\overline{\text{Nu}}_L = (\bar{h}L/k) = 0.664 \text{Re}_L^{1/2} \text{Pr}^{1/3} = 0.664(8540)^{1/2} 0.685^{1/3} = 54.1$$

$$\bar{h} = 54.1 \times 0.0469 \text{ W/m} \cdot \text{K} / 0.150 \text{ m} = 16.9 \text{ W/m}^2 \cdot \text{K}.$$

The energy balance now becomes

$$0.5 \times 5.667 \times 10^{-8} \text{ W/m}^2 \cdot \text{K}^4 (1000^4 - T_s^4) \text{ K}^4 - 16.9 \text{ W/m}^2 \cdot \text{K} (T_s - 400) \text{ K} = 0$$

which yields  $T_s \approx 850 \text{ K}$ . <

(b) Using the IHT *First Law Model* with the *Correlations and Properties* Toolpads, the effect of velocity may be determined and the results are as follows:

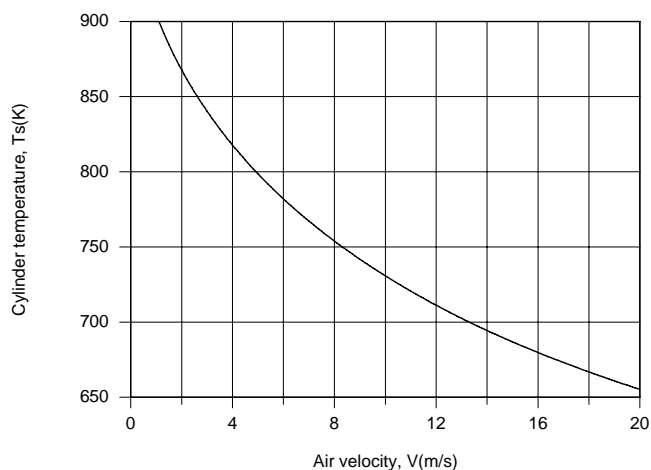

Since the convection coefficient increases with increasing  $V$  (from 18.5 to 90.6  $\text{W/m}^2 \cdot \text{K}$  for  $1 \leq V \leq 20 \text{ m/s}$ ), the cylinder temperature decreases, since a smaller value of  $(T_s - T_\infty)$  is needed to dissipate the absorbed irradiation by convection.

**COMMENTS:** The cylinder temperature exceeds the air temperature due to absorption of the incident radiation. The cylinder temperature would approach  $T_\infty$  as  $\bar{h} \rightarrow \infty$  and/or  $\alpha \rightarrow 0$ . If  $\alpha \rightarrow 0$  and  $\bar{h}$  has a small to moderate value, would  $T_s$  be larger than, equal to, or less than  $T_\infty$ ? Why?

## PROBLEM 12.101

**KNOWN:** Instrumentation pod, initially at  $87^\circ\text{C}$ , on a conveyor system passes through a large vacuum brazing furnace. Inner surface of pod surrounded by a mass of phase-change material (PCM). Outer surface with special diffuse, opaque coating of  $\epsilon_\lambda$ . Electronics in pod dissipate 50 W.

**FIND:** How long before all the PCM changes to the liquid state?

**SCHEMATIC:**

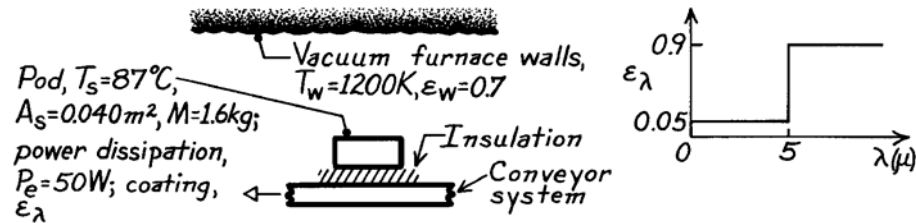

**ASSUMPTIONS:** (1) Surface area of furnace walls much larger than that of pod, (2) No convection, (3) No heat transfer to pod from conveyor, (4) Pod coating is diffuse, opaque, (5) Initially pod internal temperature is uniform at  $T_{\text{pcm}} = 87^\circ\text{C}$  and remains so during time interval  $\Delta t_m$ , (6) Surface area provided is that exposed to walls.

**PROPERTIES:** Phase-change material, PCM (given): Fusion temperature,  $T_f = 87^\circ\text{C}$ ,  $h_{fg} = 25$  kJ/kg.

**ANALYSIS:** Perform an energy balance on the pod for an interval of time  $\Delta t_m$  which corresponds to the time for which the PCM changes from solid to liquid state,

$$E_{\text{in}} - E_{\text{out}} + E_{\text{gen}} = \Delta E$$

$$\left[ (\alpha G - \epsilon E_b) A_s + P_e \right] \Delta t_m = M h_{fg}$$

where  $P_e$  is the electrical power dissipation rate,  $M$  is the mass of PCM, and  $h_{fg}$  is the heat of fusion of PCM.

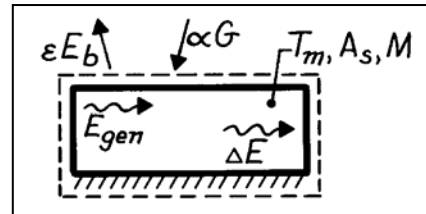

**Irradiation:**  $G = \sigma T_w^4 = 5.67 \times 10^{-8} \text{ W/m}^2 \cdot \text{K}^4 (1200 \text{ K})^4 = 117,573 \text{ W/m}^2$

**Emissive power:**  $E_b = \sigma T_m^4 = \sigma (87 + 273)^4 = 952 \text{ W/m}^2$

**Emissivity:**  $\epsilon = \epsilon_1 F_{(0-\lambda T)} + \epsilon_2 (1 - F_{(0-\lambda T)})$   $\lambda T = 5 \times 360 = 1800 \mu\text{m} \cdot \text{K}$   
 $\epsilon = 0.05 \times 0.0393 + 0.9 (1 - 0.0393)$   $F_{0-\lambda T} = 0.0393$  (Table 12.1)  
 $\epsilon = 0.867$

**Absorptivity:**  $\alpha = \alpha_1 F_{(0-\lambda T)} + \alpha_2 (1 - F_{(0-\lambda T)})$   $\lambda T = 5 \times 1200 = 6000 \mu\text{m} \cdot \text{K}$   
 $\alpha = 0.05 \times 0.7378 + 0.9 (1 - 0.7378)$   $F_{0-\lambda T} = 0.7378$  (Table 12.1)  
 $\alpha = 0.273$

Substituting numerical values into the energy balance, find,

$$\left[ (0.273 \times 117,573 - 0.867 \times 952) \text{ W/m}^2 \times 0.040 \text{ m}^2 + 50 \text{ W} \right] \Delta t_m = 1.6 \text{ kg} \times 25 \times 10^3 \text{ J/kg}$$

$$\Delta t_m = 32.5 \text{ s} = 0.54 \text{ min.}$$

<

## PROBLEM 12.102

**KNOWN:** Temperatures of furnace and surroundings separated by ceramic plate. Maximum allowable temperature and spectral absorptivity of plate.

**FIND:** (a) Minimum value of air-side convection coefficient,  $h_o$ , (b) Effect of  $h_o$  on plate temperature.

**SCHEMATIC:**

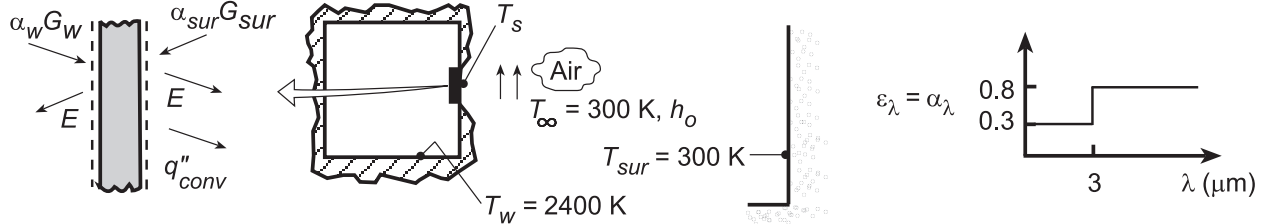

**ASSUMPTIONS:** (1) Diffuse surface, (2) Negligible temperature gradients in plate, (3) Negligible inside convection, (4) Furnace and surroundings act as blackbodies.

**ANALYSIS:** (a) From a surface energy balance on the plate,  $\alpha_w G_w + \alpha_{sur} G_{sur} = 2E + q''_{conv}$ . Hence,

$$\alpha_w \sigma T_w^4 + \alpha_{sur} \sigma T_{sur}^4 = 2\epsilon \sigma T_s^4 + h_o (T_s - T_\infty).$$

$$h_o = \frac{\alpha_w \sigma T_w^4 + \alpha_{sur} \sigma T_{sur}^4 - 2\epsilon \sigma T_s^4}{(T_s - T_\infty)}$$

Evaluating the absorptivities and emissivity,

$$\alpha_w = \int_0^\infty \alpha_\lambda G_\lambda d\lambda / G = \int_0^\infty \alpha_\lambda E_{\lambda b}(T_w) / E_b(T_w) d\lambda = 0.3F_{(0-3\mu m)} + 0.8[1 - F_{(0-3\mu m)}]$$

With  $\lambda T_w = 3 \mu m \times 2400 \text{ K} = 7200 \mu m \cdot \text{K}$ , Table 12.1  $\rightarrow F_{(0-3\mu m)} = 0.819$ . Hence,

$$\alpha_w = 0.3 \times 0.819 + 0.8(1 - 0.819) = 0.391$$

Since  $T_{sur} = 300 \text{ K}$ , irradiation from the surroundings is at wavelengths well above  $3 \mu m$ . Hence,

$$\alpha_{sur} = \int_0^\infty \alpha_\lambda E_{\lambda b}(T_{sur}) / E_b(T_{sur}) d\lambda \approx 0.800.$$

The emissivity is  $\epsilon = \int_0^\infty \epsilon_\lambda E_{\lambda b}(T_s) / E_b(T_s) d\lambda = 0.3F_{(0-3\mu m)} + 0.8[1 - F_{(0-3\mu m)}]$ . With

$\lambda T_s = 5400 \mu m \cdot \text{K}$ , Table 12.1  $\rightarrow F_{(0-3\mu m)} = 0.680$ . Hence,  $\epsilon = 0.3 \times 0.68 + 0.8(1 - 0.68) = 0.460$ .

For the maximum allowable value of  $T_s = 1800 \text{ K}$ , it follows that

$$h_o = \frac{0.391 \times 5.67 \times 10^{-8} (2400)^4 + 0.8 \times 5.67 \times 10^{-8} (300)^4 - 2 \times 0.46 \times 5.67 \times 10^{-8} (1800)^4}{(1800 - 300)}$$

$$h_o = \frac{7.335 \times 10^5 + 3.674 \times 10^2 - 5.476 \times 10^5}{1500} = 126 \text{ W/m}^2 \cdot \text{K}.$$

(b) Using the IHT *First Law Model* with the *Radiation Toolpad*, parametric calculations were performed to determine the effect of  $h_o$ .

Continued...



### PROBLEM 12.102 (Cont.)

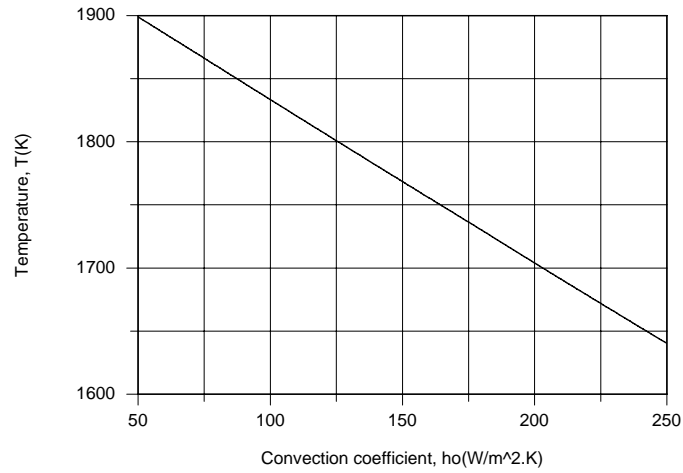

With increasing  $h_o$ , and hence enhanced convection heat transfer at the outer surface, the plate temperature is reduced.

**COMMENTS:** (1) The surface is not gray. (2) The required value of  $h_o \geq 126 \text{ W/m}^2 \cdot \text{K}$  is well within the range of air cooling.

### PROBLEM 12.103

**KNOWN:** Spectral radiative properties of thin coating applied to long circular copper rods of prescribed diameter and initial temperature. Wall and atmosphere conditions of furnace in which rods are inserted.

**FIND:** (a) Emissivity and absorptivity of the coated rods when their temperature is  $T_s = 300$  K, (b) Initial rate of change of their temperature,  $dT_s/dt$ , (c) Emissivity and absorptivity when they reach steady-state temperature, and (d) Time required for the rods, initially at  $T_s = 300$  K, to reach 1000 K.

**SCHEMATIC:**

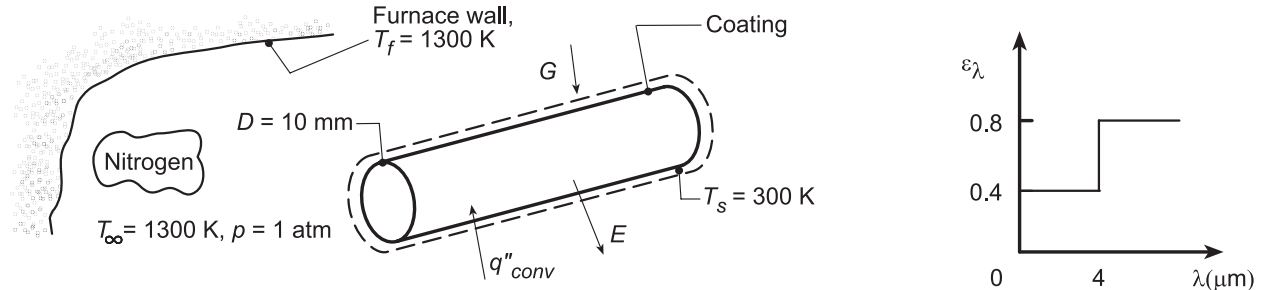

**ASSUMPTIONS:** (1) Rod temperature is uniform, (2) Nitrogen is quiescent, (3) Constant properties, (4) Diffuse, opaque surface coating, (5) Furnace walls form a blackbody cavity about the cylinders,  $G = E_b(T_f)$ , (6) Negligible end effects.

**PROPERTIES:** Table A.1, Copper (300 K):  $\rho = 8933$  kg/m<sup>3</sup>,  $c_p = 385$  J/kg·K,  $k = 401$  W/m·K; Table A.4, Nitrogen ( $T_f = 800$  K, 1 atm):  $\nu = 82.9 \times 10^{-6}$  m<sup>2</sup>/s,  $k = 0.0548$  W/m·K,  $\alpha = 116 \times 10^{-6}$  m<sup>2</sup>/s,  $Pr = 0.715$ ,  $\beta = (T_f)^{-1} = 1.25 \times 10^{-3}$  K<sup>-1</sup>.

**ANALYSIS:** (a) The total emissivity of the copper rod,  $\epsilon$ , at  $T_s = 300$  K follows from Eq. 12.43 which can be expressed in terms of the band emission factor,  $F(0 - \lambda T)$ , Eq. 12.34,

$$\epsilon = \epsilon_1 F(0 - \lambda_1 T_s) + \epsilon_2 [1 - F(0 - \lambda_1 T_s)] \quad (1)$$

$$\epsilon = 0.4 \times 0.0021 + 0.8 [1 - 0.0021] = 0.799 \quad <$$

where, from Table 12.1, with  $\lambda_1 T_s = 4 \mu\text{m} \times 300 \text{ K} = 1200 \mu\text{m}\cdot\text{K}$ ,  $F(0 - \lambda T) = 0.0021$ . The total absorptivity,  $\alpha$ , for irradiation for the furnace walls at  $T_f = 1300$  K, is

$$\alpha = \epsilon_1 F(0 - \lambda_1 T_f) + \epsilon_2 [1 - F(0 - \lambda_1 T_f)] \quad (2)$$

$$\alpha = 0.4 \times 0.6590 + 0.8 [1 - 0.6590] = 0.536 \quad <$$

where, from Table 12.1, with  $\lambda_1 T_f = 4 \mu\text{m} \times 1300 \text{ K} = 5200 \text{ K}$ ,  $F(0 - \lambda T) = 0.6590$ .

(b) From an energy balance on a control volume about the rod,

$$\dot{E}_{st} = \rho c_p \left( \pi D^2 / 4 \right) L (dT/dt) = \dot{E}_{in} - \dot{E}_{out} = \pi DL [\alpha G + \bar{h} (T_\infty - T_s) - E]$$

$$dT_s/dt = 4 \left[ \alpha G + \bar{h} (T_\infty - T_s) - \epsilon \sigma T_s^4 \right] / \rho c_p D. \quad (3)$$

With

$$Ra_D = \frac{g \beta (T_\infty - T_s) D^3}{\nu \alpha} = \frac{9.8 \text{ m}^2/\text{s} (1.25 \times 10^{-3} \text{ K}^{-1}) 1000 \text{ K} (0.01 \text{ m})^3}{82.9 \times 10^{-6} \text{ m}^2/\text{s} \times 116 \times 10^{-6} \text{ m}^2/\text{s}} = 1274 \quad (4)$$

The Churchill-Chu correlation of Chapter 9 gives

Continued...

### PROBLEM 12.103 (Cont.)

$$\bar{h} = \frac{0.0548}{0.01 \text{ m}} \left\{ 0.60 + \frac{0.387(1274)^{1/6}}{\left[ 1 + (0.559/0.715)^{9/16} \right]^{8/27}} \right\}^2 = 15.1 \text{ W/m}^2 \cdot \text{K} \quad (5)$$

With values of  $\varepsilon$  and  $\alpha$  from part (a), the rate of temperature change with time is

$$dT_s/dt = \frac{4 \left[ 0.53 \times 5.67 \times 10^{-8} \text{ W/m}^2 \cdot \text{K}^4 \times (1300 \text{ K})^4 + 15.1 \text{ W/m}^2 \cdot \text{K} \times 1000 \text{ K} - 0.8 \times 5.67 \times 10^{-8} \text{ W/m}^2 \cdot \text{K} \times (300 \text{ K})^4 \right]}{8933 \text{ kg/m}^3 \times 385 \text{ J/kg} \cdot \text{K} \times 0.01 \text{ m}}$$

$$dT_s/dt = 1.16 \times 10^{-4} [85,829 + 15,100 - 3767] \text{ K/s} = 11.7 \text{ K/s} . \quad <$$

(c) Under steady-state conditions,  $T_s = T_\infty = T_f = 1300 \text{ K}$ . For this situation,  $\varepsilon = \alpha$ , hence

$$\varepsilon = \alpha = 0.536 \quad <$$

(d) The time required for the rods, initially at  $T_s(0) = 300 \text{ K}$ , to reach  $1000 \text{ K}$  can be determined using the lumped capacitance method. Using the *IHT Lumped Capacitance Model*, considering convection, irradiation and emission processes; the *Correlations Tool, Free Convection, Horizontal Cylinder*; *Radiation Tool, Band Emission Fractions*; and a user-generated *Lookup Table Function* for the nitrogen thermophysical properties, find

$$T_s(t_0) = 1000 \text{ K} \quad t_0 = 81.8 \text{ s} \quad <$$

**COMMENTS:** (1) To determine the validity of the lumped capacitance method to this heating process, evaluate the approximate Biot number,  $Bi = \bar{h}D/k = 15 \text{ W/m}^2 \cdot \text{K} \times 0.010 \text{ m}/401 \text{ W/m} \cdot \text{K} = 0.0004$ . Since  $Bi \ll 0.1$ , the method is appropriate.

(2) The IHT workspace with the model used for part (c) is shown below.

```
// Lumped Capacitance Model - irradiation, emission, convection
/* Conservation of energy requirement on the control volume, CV. */
Edotin - Edotout = Edotst
Edotin = As * ( + Gabs)
Edotout = As * ( + q"cv + E )
Edotst = rho * vol * cp * Der(Ts,t)
//Convection heat flux for control surface CS
q"cv = h * ( Ts - Tinf )
// Emissive power of CS
E = eps * Eb
Eb = sigma * Ts^4
sigma = 5.67e-8 // Stefan-Boltzmann constant, W/m^2.K^4
// Absorbed irradiation from large surroundings on CS
Gabs = alpha * G
G = sigma * Tf^4
/* The independent variables for this system and their assigned numerical values are */
As = pi * D * 1 // surface area, m^2
vol = pi * D^2 / 4 * 1 // vol, m^3
rho = 8933 // density, kg/m^3
cp = 433 // specific heat, J/kg.K; evaluated at 800 K
// Convection heat flux, CS
//h = // convection coefficient, W/m^2.K
Tinf = 1300 // fluid temperature, K
// Emission, CS
//eps = // emissivity
// Irradiation from large surroundings, CS
//alpha = // absorptivity
Tf = 1300 // surroundings temperature, K
```

Continued...

## PROBLEM 12.103 (Cont.)

### // Radiative Properties Tool - Band Emission Fraction

```
eps = eps1 * FL1Ts + eps2 * (1 - FL1Ts)
/* The blackbody band emission factor, Figure 12.14 and Table 12.1, is */
FL1Ts = F_lambda_T(lambda1, Ts) // Eq 12.34
// where units are lambda (micrometers, mum) and T (K)
alpha = eps1 * FL1Tf + eps2 * (1 - FL1Tf)
/* The blackbody band emission factor, Figure 12.14 and Table 12.1, is */
FL1Tf = F_lambda_T(lambda1, Tf) // Eq 12.34
```

### // Assigned Variables:

```
D = 0.010 // Cylinder diameter, m
eps1 = 0.4 // Spectral emissivity for lambda < lambda1
eps2 = 0.8 // Spectral emissivity for lambda > lambda1
lambda1 = 4 // Wavelength, mum
```

### // Correlations Tool - Free Convection, Cylinder, Horizontal:

```
NuDbar = NuD_bar_FC_HC(RaD, Pr) // Eq 9.34
NuDbar = h * D / k
RaD = g * beta * deltaT * D^3 / (nu * alphan) //Eq 9.25
deltaT = abs(Ts - Tinf)
g = 9.8 // gravitational constant, m/s^2
// Evaluate properties at the film temperature, Tf.
Tff = Tfluid_avg(Tinf, Ts)
```

### // Properties Tool - Nitrogen: Lookup Table Function "nitrog"

```
nu = lookupval (nitrog, 1, Tff, 2)
k = lookupval (nitrog, 1, Tff, 3)
alphan = lookupval (nitrog, 1, Tff, 4)
Pr = lookupval (nitrog, 1, Tff, 5)
beta = 1 / Tff
/* Lookup table function, nitrog; from Table A.4 1 atm):
Columns: T(K), nu(m^2/s), k(W/m.K), alpha(m^2/s), Pr
300 1.586E-5 0.0259 2.21E-5 0.716
350 2.078E-5 0.0293 2.92E-5 0.711
400 2.616E-5 0.0327 3.71E-5 0.704
450 3.201E-5 0.0358 4.56E-5 0.703
500 3.824E-5 0.0389 5.47E-5 0.7
550 4.17E-5 0.0417 6.39E-5 0.702
600 5.179E-5 0.0446 7.39E-5 0.701
700 6.671E-5 0.0499 9.44E-5 0.706
800 8.29E-5 0.0548 0.000116 0.715
900 0.0001003 0.0597 0.000139 0.721
1000 0.0001187 0.0647 0.000165 0.721 */
```

### PROBLEM 12.104

**KNOWN:** Large combination convection-radiation oven heating a cylindrical product of a prescribed spectral emissivity.

**FIND:** (a) Initial heat transfer rate to the product when first placed in oven at 300 K, (b) Steady-state temperature of the product, (c) Time to achieve a temperature within 50°C of the steady-state temperature.

**SCHEMATIC:**

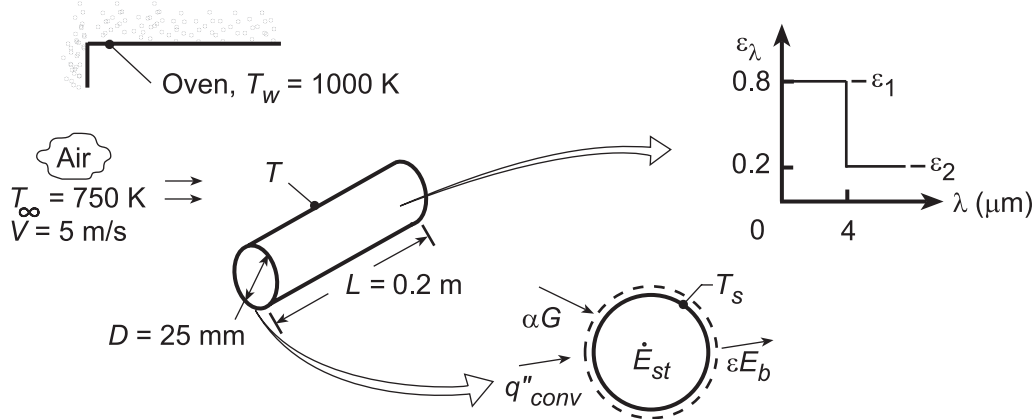

**ASSUMPTIONS:** (1) Cylinder is opaque-diffuse, (2) Oven walls are very large compared to the product, (3) Cylinder end effects are negligible, (4)  $\epsilon_\lambda$  is dependent of temperature.

**PROPERTIES:** Table A-4, Air ( $T_f = 525$  K, 1 atm):  $\nu = 42.2 \times 10^{-6} \text{ m}^2/\text{s}$ ,  $k = 0.0423 \text{ W/m}\cdot\text{K}$ ,  $\text{Pr} = 0.684$ ; ( $T_f = 850$  K (assumed), 1 atm):  $\nu = 93.8 \times 10^{-6} \text{ m}^2/\text{s}$ ,  $k = 0.0596 \text{ W/m}\cdot\text{K}$ ,  $\text{Pr} = 0.716$ .

**ANALYSIS:** (a) The net heat rate to the product is  $q_{\text{net}} = A_s(q''_{\text{conv}} + \alpha G - \epsilon E_b)$ , or

$$q_{\text{net}} = \pi DL[\bar{h}(T_\infty - T) + \alpha G - \epsilon \sigma T^4] \quad (1)$$

Evaluating properties at  $T_f = 525$  K,  $\text{Re}_D = VD/\nu = 5 \text{ m/s} \times 0.025 \text{ m} / 42.2 \times 10^{-6} \text{ m}^2/\text{s} = 2960$ , and the Churchill-Bernstein correlation of Chapter 7 yields

$$\overline{\text{Nu}}_D = \frac{\bar{h}D}{k} = 0.3 + \frac{0.62 \text{Re}_D^{1/2} \text{Pr}^{1/3}}{[1 + (0.4/\text{Pr})^{2/3}]^{1/4}} \left[ 1 + \left( \frac{\text{Re}_D}{282,000} \right)^{5/8} \right]^{4/5} = 27.5$$

Hence,

$$\bar{h} = \frac{0.0423 \text{ W/m}\cdot\text{K}}{0.025 \text{ m}} \times 27.5 = 46.5 \text{ W/m}^2 \cdot \text{K}.$$

The total, hemispherical emissivity of the diffuse, spectrally selective surface follows from Eq. 12.43,

$\epsilon = \int_0^\infty \epsilon_\lambda(\lambda, T_s) E_{\lambda, b} / \sigma T_s^4 = \epsilon_1 F_{(0 \rightarrow 4 \mu\text{m})} + \epsilon_2 (1 - F_{(0 \rightarrow 4 \mu\text{m})})$ , where  $\lambda T = 4 \mu\text{m} \times 300 \text{ K} = 1200 \mu\text{m}\cdot\text{K}$  and  $F_{(0 \rightarrow \lambda T)} = 0.002$  (Table 12.1). Hence,  $\epsilon = 0.8 \times 0.002 + 0.2 (1 - 0.002) = 0.201$ .

The absorptivity is for irradiation from the oven walls which, because they are large and isothermal, behave as a black surface at 1000 K. From Eq. 12.52, with  $G_\lambda = E_{\lambda, b}(\lambda, 1000 \text{ K})$  and  $\alpha_\lambda = \epsilon_\lambda$ ,

$$\alpha = \epsilon_1 F_{(0 \rightarrow 4 \mu\text{m})} + \epsilon_2 (1 - F_{(0 \rightarrow 4 \mu\text{m})}) = 0.8 \times 0.481 + 0.2(1 - 0.481) = 0.489$$

where, for  $\lambda T = 4 \times 1000 = 4000 \mu\text{m}\cdot\text{K}$  from Table 12.1,  $F_{(0 \rightarrow \lambda T)} = 0.481$ . From Eq. (1) the net initial

heat rate is  $q_{\text{net}} = \pi \times 0.025 \text{ m} \times 0.2 \text{ m} [46.5 \text{ W/m}^2 \cdot \text{K} (750 - 300) \text{ K} + 0.489 \sigma (1000)^4 \text{ K}^4 - 0.201 \sigma (300 \text{ K})^4]$

Continued...

### PROBLEM 12.104 (Cont.)

$$q = 763 \text{ W.}$$

&lt;

(b) For the steady-state condition, the net heat rate will be zero, and the energy balance yields,

$$0 = \bar{h}(T_\infty - T) + \alpha G - \varepsilon \sigma T^4 \quad (2)$$

Evaluating properties at an assumed film temperature of  $T_f = 850 \text{ K}$ ,  $Re_D = VD/\nu = 5 \text{ m/s} \times 0.025 \text{ m} / 93.8 \times 10^{-6} \text{ m}^2/\text{s} = 1333$ , and the Churchill-Bernstein correlation yields  $\overline{Nu}_D = 18.6$ . Hence,  $\bar{h} = 18.6 (0.0596 \text{ W/m} \cdot \text{K}) / 0.025 \text{ m} = 44.3 \text{ W/m}^2 \cdot \text{K}$ . Since irradiation from the oven walls is fixed, the absorptivity is unchanged, in which case  $\alpha = 0.489$ . However, the emissivity depends on the product temperature. Assuming  $T = 950 \text{ K}$ , we obtain

$$\varepsilon = \varepsilon_1 F_{(0 \rightarrow 4 \mu\text{m})} + \varepsilon_2 (1 - F_{(0 \rightarrow 4 \mu\text{m})}) = 0.8 \times 0.443 + 0.2(1 - 0.443) = 0.466$$

where for  $\lambda T = 4 \times 950 = 3800 \mu\text{m} \cdot \text{K}$ ,  $F_{0-\lambda T} = 0.443$ , from Table 12.1. Substituting values into Eq. (2) with  $\sigma = 5.67 \times 10^{-8} \text{ W/m}^2 \cdot \text{K}^4$ ,

$$0 = 44.3 (750 - T) + 0.489 \sigma (1000 \text{ K})^4 - 0.466 \sigma T^4.$$

A trial-and-error solution yields  $T \approx 930 \text{ K}$ .

&lt;

(c) Using the IHT *Lumped Capacitance Model* with the *Correlations, Properties* (for copper and air) and *Radiation Toolpads*, the transient response of the cylinder was computed and the time to reach  $T = 880 \text{ K}$  is

$$t \approx 537 \text{ s.}$$

&lt;

**COMMENTS:** Note that  $\bar{h}$  is relatively insensitive to  $T$ , while  $\varepsilon$  is not. At  $T = 930 \text{ K}$ ,  $\varepsilon = 0.456$ .

## PROBLEM 12.105

**KNOWN:** Workpiece, initially at 25°C, to be annealed at a temperature above 725°C for a period of 5 minutes and then cooled; furnace wall temperature and convection conditions; cooling surroundings and convection conditions.

**FIND:** (a) Emissivity and absorptivity of the workpiece at 25°C when it is placed in the furnace, (b) Net heat rate per unit area into the workpiece for this initial condition; change in temperature with time,  $dT/dt$ , for the workpiece; (c) Calculate the time for the workpiece to cool from 750°C to a safe-to-touch temperature of 40°C if the cool surroundings and cooling air temperature are 25°C and the convection coefficient is 100 W/m<sup>2</sup>·K.

**SCHEMATIC:**

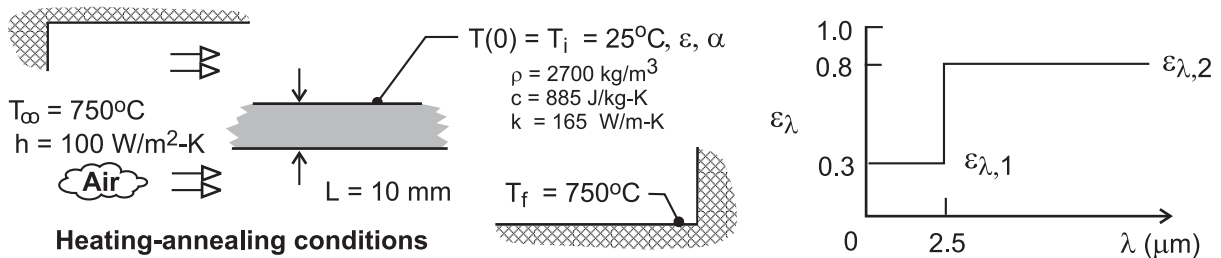

**ASSUMPTIONS:** (1) Workpiece is opaque and diffuse, (2) Spectral emissivity is independent of temperature, and (3) Furnace and cooling environment are large isothermal surroundings.

**ANALYSIS:** (a) Using Eqs. 12.43 and 12.52,  $\epsilon$  and  $\alpha$  can be determined using band-emission factors, Eq. 12.34 and 12.35.

*Emissivity, workpiece at 25°C*

$$\begin{aligned}\epsilon &= \epsilon_{\lambda 1} \cdot F_{(0-\lambda T)} + \epsilon_{\lambda 2} (1 - F_{(0-\lambda T)}) \\ \epsilon &= 0.3 \times 1.6 \times 10^{-5} + 0.8 \times (1 - 1.6 \times 10^{-5}) = 0.8\end{aligned} \quad <$$

where  $F_{(0-\lambda T)}$  is determined from Table 12.1 with  $\lambda T = 2.5 \mu\text{m} \times 298 \text{ K} = 745 \mu\text{m}\cdot\text{K}$ .

*Absorptivity, furnace temperature  $T_f = 750^\circ\text{C}$*

$$\begin{aligned}\alpha &= \epsilon_{\lambda 1} \cdot F_{(0-\lambda, T)} + \epsilon_{\lambda 2} \cdot (1 - F_{(0-\lambda, T)}) \\ \alpha &= 0.3 \times 0.174 + 0.8 \times (1 - 0.174) = 0.713\end{aligned} \quad <$$

where  $F_{(0-\lambda T)}$  is determined with  $\lambda T = 2.5 \mu\text{m} \times 1023 \text{ K} = 2557.5 \mu\text{m}\cdot\text{K}$ .

(b) For the initial condition,  $T(0) = T_i$ , the energy balance shown schematically below is written in terms of the net heat rate  $\dot{in}$ ,

Continued ...

**PROBLEM 12.105 (Cont.)**

$$\dot{E}_{\text{in}}'' - \dot{E}_{\text{out}}'' = \dot{E}_{\text{st}}'' \quad \text{and} \quad q_{\text{net,in}}'' = \dot{E}_{\text{in}}'' - \dot{E}_{\text{out}}''$$

$$q_{\text{net,in}}'' = 2[q_{\text{cv}}'' - \varepsilon E_b(T_i) + \alpha E_b(T_f)]$$

where  $G = E_b(T_f)$ . Substituting numerical values,

$$q_{\text{net,in}}'' = 2 \left[ h(T_\infty - T_i) - \varepsilon \sigma T_i^4 + \alpha \sigma T_f^4 \right]$$

$$q_{\text{net,in}}'' = 2 \left[ 100 \text{ W/m}^2 \cdot \text{K} (750 - 25) \text{ K} - 0.8 \times 5.67 \times 10^{-8} \text{ W/m}^2 \cdot \text{K}^4 (298 \text{ K})^4 + 0.713 \times 5.67 \times 10^{-8} \text{ W/m}^2 \cdot \text{K}^4 (1023 \text{ K})^4 \right]$$

$$q_{\text{net,in}}'' = 2 \times 116.4 \text{ kW/m}^2 = 233 \text{ kW/m}^2 \quad <$$

Considering the energy storage term,

$$\dot{E}_{\text{st}}'' = \rho c L \left( \frac{dT}{dt} \right)_i = q_{\text{net,in}}''$$

$$\left( \frac{dT}{dt} \right)_i = \frac{q_{\text{net,in}}''}{\rho c L} = \frac{233 \text{ kW/m}^2}{2700 \text{ kg/m}^3 \times 885 \text{ J/kg} \cdot \text{K} \times 0.010 \text{ m}} = 9.75 \text{ K/s} \quad <$$

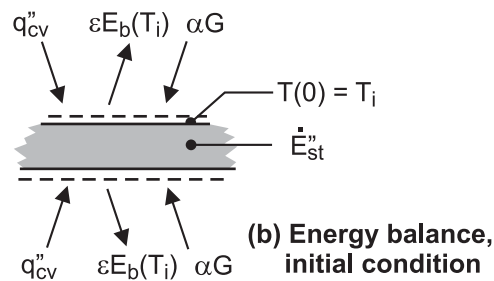

(c) The energy balance of Part (b), using the lumped capacitance method with the *IHT DER* ( $T, t$ ) function, has the form,

$$2 \left[ h(T_\infty - T) - \varepsilon \sigma T^4 + \alpha \sigma T_f^4 \right] = \rho c L \text{ DER}(T, t)$$

Continued ...



## PROBLEM 12.105 (Cont.)

The time to cool the workpiece from 750°C to the safe-to-touch temperature of 40°C can be determined using the *IHT* code in the Comments. The cooling conditions are  $T_\infty = 25^\circ\text{C}$  and  $h = 100 \text{ W/m}^2\cdot\text{K}$  with  $T_{\text{sur}} = 25^\circ\text{C}$ . The emissivity is still evaluated as in the Comments, but the absorptivity, which depends upon the surrounding temperature, is  $\alpha = 0.80$ . From the results in the *IHT* workspace, find

$$T(t_c) = 40^\circ\text{C} \quad \text{when} \quad t_c = 413 \text{ s} \quad \leftarrow$$

**COMMENTS:** (1) With the relation for  $\varepsilon$  of Part (a) in the *IHT* workspace, and using the *Radiation | Band Emission* tool,  $\varepsilon$  as a function of workpiece temperature is calculated and plotted below.

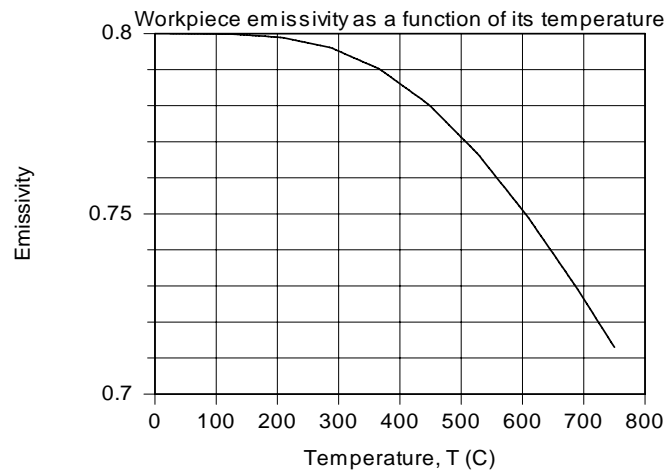

As expected,  $\varepsilon$  decreases with increasing  $T$ , and when  $T = T_f = 750^\circ\text{C}$ ,  $\varepsilon = \alpha = 0.713$ . Why is that so?

(2) The *IHT* code to obtain the heating time, including emissivity as a function of the workpiece temperature, Part (b), is shown below, complete except for the input variables.

```
/* Analysis. The radiative properties and net heat flux in are calculated when the workpiece is
just inserted into the furnace. The workpiece experiences emission, absorbed irradiation and
convection processes. See Help | Solver | Intrinsic Functions for information on DER(T, t). */
```

```
/* Results - conditions at t = 186 s, Ts C - 725 C
```

FL1T	T_C	Tf	L	Tf_C	Tinf_C	eps1	eps2	h	k
	lambda1	rho	t	T					
0.1607	725.1	1023	0.01	750	750	0.3	0.8	100	165
	2.5	2700	186	998.1	*/				

```
// Energy Balance
```

```
2 * ( h * (Tinf - T) + alpha * G - eps * sigma * T^4) = rho * cp * L * DER(T,t)
```

```
sigma = 5.67e-8
```

```
G = sigma * Tf^4
```

```
// Emissivity and absorptivity
```

```
eps = FL1T * eps1 + (1 - FL1T) * eps2
```

```
FL1T = F_lambda_T(lambda1, T) // Eq 12.34
```

```
alpha = 0.713
```

```
// Temperature conversions
```

```
T_C = T - 273 // For customary units, graphical output
```

```
Tf_C = Tf - 273
```

```
Tinf_C = Tinf - 273
```

## PROBLEM 12.106

**KNOWN:** For the semiconductor silicon, the spectral distribution of absorptivity,  $\alpha_\lambda$ , at selected temperatures. High-intensity, tungsten halogen lamps having spectral distribution approximating that of a blackbody at 2800 K.

**FIND:** (a) 1%-limits of the spectral band that includes 98% of the blackbody radiation corresponding to the spectral distribution of the lamps; spectral region for which you need to know the spectral absorptivity; (b) Sketch the variation of the total absorptivity as a function of silicon temperature; explain key features; (c) Calculate the total absorptivity at 400, 600 and 900°C for the lamp irradiation; explain results and the temperature dependence; Calculate the total emissivity of the wafer at 600 and 900°C; explain results and the temperature dependence; and (d) Irradiation on the upper surface required to maintain the wafer at 600°C in a vacuum chamber with walls at 20°C. Use the *Look-up Table* and *Integral Functions of IHT* to perform the necessary integrations.

**SCHEMATIC:**

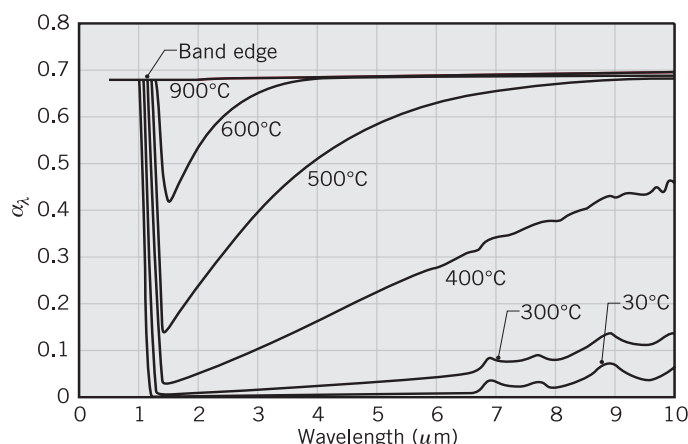

**ASSUMPTIONS:** (1) Silicon is a diffuse emitter, (2) Chamber is large, isothermal surroundings for the wafer, (3) Wafer is isothermal.

**ANALYSIS:** (a) From Eqs. 12.28 and 12.29, using Table 12.1 for the band emission factors,  $F_{(0-\lambda T)}$ , equal to 0.01 and 0.99 are:

$$F_{(0 \rightarrow \lambda_1 T)} = 0.01 \text{ at } \lambda_1 \cdot T = 1437 \mu\text{m} \cdot \text{K}$$

$$F_{(0 \rightarrow \lambda_2 T)} = 0.99 \text{ at } \lambda_2 \cdot T = 23,324 \mu\text{m} \cdot \text{K}$$

So that we have  $\lambda_1$  and  $\lambda_2$  limits for several temperatures, the following values are tabulated.

T(°C)	T(K)	$\lambda_1(\mu\text{m})$	$\lambda_2(\mu\text{m})$
-	2800	0.51	8.33
400	673	2.14	34.7
600	873	1.65	26.7
900	1173	1.23	19.9

For the 2800 K blackbody lamp irradiation, we need to know the spectral absorptivity over the spectral range 0.51 to 8.33  $\mu\text{m}$  in order to include 98% of the radiation.

(b) The spectral absorptivity is calculated from Eq. 12.52 in which the spectral distribution of the lamp irradiation  $G_\lambda$  is proportional to the blackbody spectral emissive power  $E_{\lambda,b}(\lambda, T)$  at the temperature of lamps,  $T_\ell = 2800 \text{ K}$ .

$$\alpha_\ell = \frac{\int_0^\infty \alpha_\lambda G_\lambda d\lambda}{\int_0^\infty G_\lambda d\lambda} = \frac{\int_0^\infty \alpha_\lambda E_{\lambda,b}(\lambda, 2800 \text{ K})}{\sigma T_\ell^4}$$

Continued ...

### PROBLEM 12.106 (Cont.)

For 2800 K, the peak of the blackbody curve is at 1  $\mu\text{m}$ ; the limits of integration for 98% coverage are 0.5 to 8.3  $\mu\text{m}$  according to part (a) results. Note that  $\alpha_\lambda$  increases at all wavelengths with temperature, until around 900°C where the behavior is gray. Hence, we'd expect the total absorptivity of the wafer for lamp irradiation to appear as shown in the graph below.

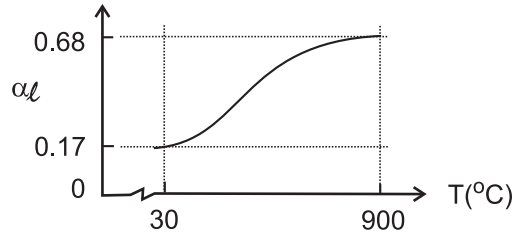

At 900°C, since the wafer is gray, we expect  $\alpha_\ell = \alpha_\lambda \approx 0.68$ . Near room temperature, since  $\alpha_\lambda \approx 0$  beyond the band edge,  $\alpha_\ell$  is dependent upon  $\alpha_\lambda$  in the spectral region below and slightly beyond the peak. From the blackbody tables, the band emission fraction to the short-wavelength side of the peak is 0.25. Hence, estimate  $\alpha_\ell \approx 0.68 \times 0.25 = 0.17$  at these low temperatures. The increase of  $\alpha_\ell$  with temperature is at first moderate, since the longer wavelength region is less significant than is the shorter region. As temperature increases, the  $\alpha_\lambda$  closer to the peak begin to change more noticeably, explaining the greater dependence of  $\alpha_\ell$  on temperature.

(c) The integration of part (b) can be performed numerically using the *IHT INTEGRAL* function and specifying the spectral absorptivity in a *Lookup Table* file (\*.lut). The code is shown in the Comments (1) and the results are:

$T_w(^{\circ}\text{C})$	400	600	900	
$\alpha_\ell$	0.30	0.59	0.68	<

The total emissivity can be calculated from Eq. 12.36, recognizing that  $\varepsilon_\lambda = \alpha_\lambda$  and that for silicon temperatures of 600 and 900°C, the 1% limits for the spectral integration are 1.65 - 26.7  $\mu\text{m}$  and 1.23 - 19.9  $\mu\text{m}$ , respectively. The integration is performed in the same manner as described above; see Comments (2).

$T(^{\circ}\text{C})$	600	900	
$\varepsilon$	0.66	0.68	<

As the silicon temperature increases, the peak of the corresponding blackbody emissive power shifts to shorter wavelengths. In general, this will reduce  $\varepsilon$ . However, this reduction is offset by the dependence of  $\varepsilon_\lambda$  on temperature, which is quite strong. As the temperature increases,  $\varepsilon_\lambda$  increases significantly.

(d) From an energy balance on the silicon wafer with irradiation on the upper surface as shown in the schematic below, calculate the irradiation required to maintain the wafer at 600°C.

$$\dot{E}_{\text{in}}'' - \dot{E}_{\text{out}}'' = 0 \qquad \alpha_\ell G_\ell - 2[\varepsilon E_b(T_w) - \alpha_{\text{sur}} E_b(T_{\text{sur}})] = 0$$

Recognize that  $\alpha_{\text{sur}}$  corresponds to the spectral distribution of  $E_{\lambda,b}(T_{\text{sur}})$ ; that is, upon  $\alpha_\lambda$  for long wavelengths ( $\lambda_{\text{max}} \approx 10 \mu\text{m}$ ). We assume  $\alpha_{\text{sur}} \approx 0.1$ , and with  $T_{\text{sur}} = 20^{\circ}\text{C}$ , find

Continued ...

### PROBLEM 12.106 (Cont.)

$$0.59G_{\ell} - 2\sigma \left[ 0.66(600 + 273)^4 \text{K}^4 - 0.1(20 + 273)^4 \text{K}^4 \right] = 0$$

$$G_{\ell} = 73.5 \text{ kW} / \text{m}^2$$

<

where  $E_b(T) = \sigma T^4$  and  $\sigma = 5.67 \times 10^{-8} \text{ W} / \text{m}^2 \cdot \text{K}^4$ .

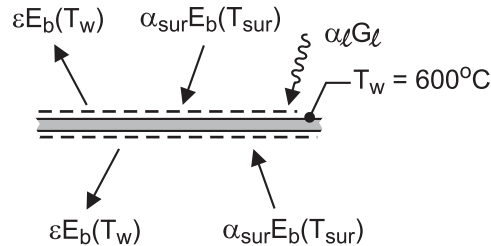

**COMMENTS:** (1) The *IHT* code to obtain the total absorptivity for the lamp irradiation,  $\alpha_{\ell}$  for a wafer temperature of  $400^{\circ}\text{C}$  is shown below. Similar look-up tables were written for the spectral absorptivity for  $600$  and  $800^{\circ}\text{C}$ .

```

/* Results; integration for total absorptivity of lamp irradiation
T = 400 C; find abs_t = 0.30
ILb      absL      abs_t      C1          C2          T          sigma      lambda
1773     0.45     0.3012     3.742E8     1.439E4     2800       5.67E-8    10      */

// Input variables
T = 2800           // Lamp blackbody distribution

// Total absorptivity integral, Eq. 12.52
abs_t = pi * integral(ILsi, lambda) / (sigma * T^4)           // See Help | Solver
sigma = 5.67e-8

// Blackbody spectral intensity, Tools | Radiation
/* From Planck's law, the blackbody spectral intensity is */
ILsi = absL * ILb
ILb = I_lambda_b(lambda, T, C1, C2)           // Eq. 12.29
// where units are ILb(W/m^2.sr.mum), lambda (mum) and T (K) with
C1 = 3.7420e8           // First radiation constant, W-mum^4/m^2
C2 = 1.4388e4           // Second radiation constant, mum-K
// and (mum) represents (micrometers).

// Spectral absorptivity function
absL = LOOKUPVAL(abs_400, 1, lambda, 2)       // Silicon spectral data at 400 C
//absL = LOOKUPVAL(abs_600, 1, lambda, 2)       // Silicon spectral data at 600 C
//absL = LOOKUPVAL(abs_900, 1, lambda, 2)       // Silicon spectral data at 900 C

// Lookup table values for Si spectral data at 600 C
/* The table file name is abs_400.lut, with 2 columns and 10 rows
0.5      0.68
1.2      0.68
1.3      0.025
2        0.05
3        0.1
4        0.17
5        0.22
6        0.28
8        0.37
10       0.45 */

```

(2) The *IHT* code to obtain the total emissivity for a wafer temperature of  $600^{\circ}\text{C}$  has the same organization as for obtaining the total absorptivity. We perform the integration, however, with the blackbody spectral emissivity evaluated at the wafer temperature (rather than the lamp temperature). The same look-up file for the spectral absorptivity created in the *IHT* code above can be used.

## PROBLEM 12.107

**KNOWN:** Solar irradiation of  $1100 \text{ W/m}^2$  incident on a flat roof surface of prescribed solar absorptivity and emissivity; air temperature and convection heat transfer coefficient.

**FIND:** (a) Roof surface temperature, (b) Effect of absorptivity, emissivity and convection coefficient on temperature.

**SCHEMATIC:**

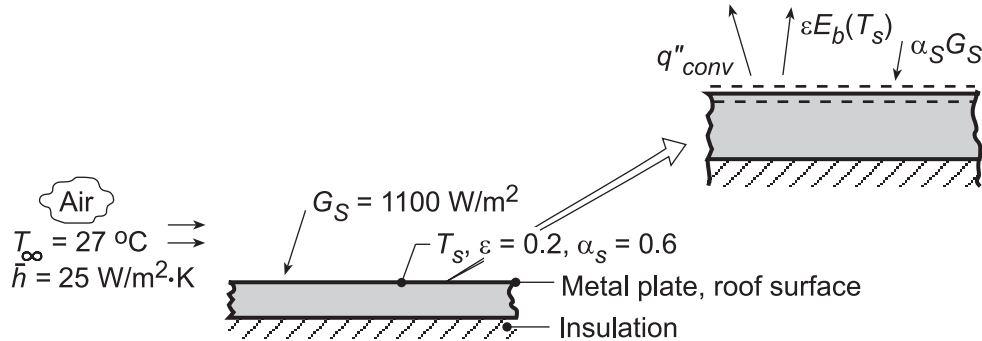

**ASSUMPTIONS:** (1) Steady-state conditions, (2) Back-side of plate is perfectly insulated, (3) Negligible irradiation to plate by atmospheric (sky) emission.

**ANALYSIS:** (a) Performing a surface energy balance on the exposed side of the plate,

$$\alpha_S G_S - q''_{\text{conv}} - \epsilon E_b(T_s) = 0 \quad \alpha_S G_S - \bar{h}(T_s - T_\infty) - \epsilon \sigma T_s^4 = 0$$

Substituting numerical values and using absolute temperatures,

$$0.6 \times 1100 \frac{\text{W}}{\text{m}^2} - 25 \frac{\text{W}}{\text{m}^2 \cdot \text{K}} (T_s - 300) \text{K} - 0.2 (5.67 \times 10^{-8} \text{ W/m}^2 \cdot \text{K}^4) T_s^4 = 0$$

Regrouping,  $8160 = 25T_s + 1.1340 \times 10^{-8} T_s^4$ , and performing a trial-and-error solution,

$$T_s = 321.5 \text{ K} = 48.5^\circ\text{C}.$$

(b) Using the IHT *First Law Model* for a plane wall, the following results were obtained.

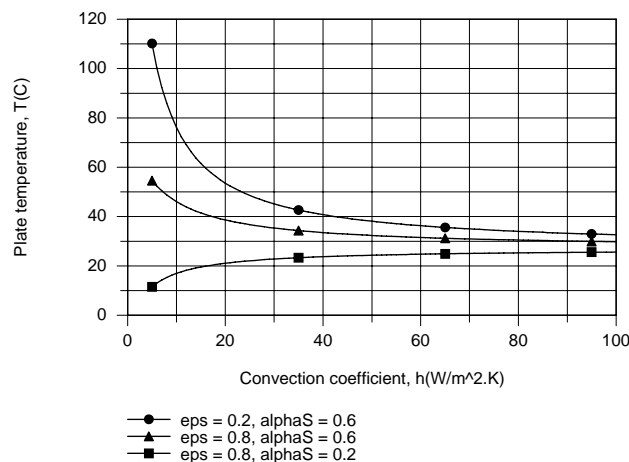

Irrespective of the value of  $\bar{h}$ ,  $T$  decreases with increasing  $\epsilon$  (due to increased emission) and decreasing  $\alpha_S$  (due to reduced absorption of solar energy). For moderate to large  $\alpha_S$  and/or small  $\epsilon$  (net radiation transfer to the surface)  $T$  decreases with increasing  $\bar{h}$  due to enhanced cooling by convection. However, for small  $\alpha_S$  and large  $\epsilon$ , emission exceeds absorption, dictating convection heat transfer to the surface and hence  $T < T_\infty$ . With increasing  $\bar{h}$ ,  $T \rightarrow T_\infty$ , irrespective of the values of  $\alpha_S$  and  $\epsilon$ .

**COMMENTS:** To minimize the roof temperature, the value of  $\epsilon/\alpha_S$  should be maximized.

## PROBLEM 12.108

**KNOWN:** Solar flux above Earth's atmosphere. Distance of Earth, Venus, and Mars from the sun. Measured average temperatures of planets.

**FIND:** Planet temperatures neglecting atmospheric radiation effects and assuming gray behavior. Planet most affected by radiation transfer through its atmosphere.

**SCHEMATIC:**

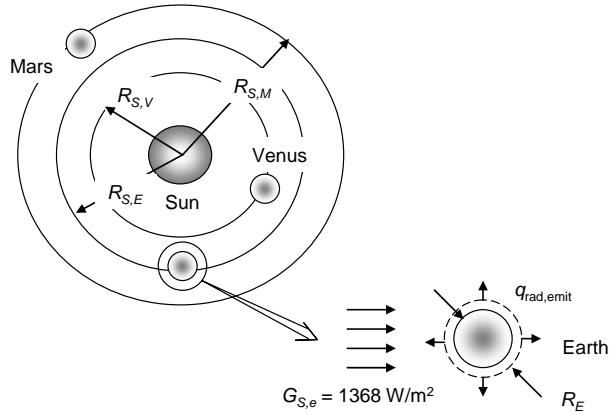

**ASSUMPTIONS:** (1) Steady-state conditions, (2) Planets are at constant distance from sun, (3) Atmosphere has no effect on radiation heat transfer, (4) Planets have gray surfaces, (5) Negligible radiation from space.

**ANALYSIS:** The energy balance for each planet is between absorbed solar radiation and emitted radiation. The appropriate area for the intercepted solar radiation is the projected area  $A_p = \pi R^2$ , where  $R$  is the planet's radius, thus

$$q_{\text{rad,abs}} = \alpha G_s A_p$$

Radiation is emitted from the entire surface area of the planet,  $A_s = 4\pi R^2$ , therefore the emitted radiation is

$$q_{\text{rad,emit}} = \varepsilon \sigma T_s^4 A_s$$

The energy balance becomes

$$\begin{aligned} q_{\text{rad,abs}} - q_{\text{rad,emit}} &= 0 \\ \alpha G_s \pi R^2 - \varepsilon \sigma T_s^4 4\pi R^2 &= 0 \end{aligned}$$

With gray surface behavior,  $\alpha = \varepsilon$ , we find

$$T_s = \left( \frac{G_s}{4\sigma} \right)^{1/4}$$

The solar irradiation is different for each planet because they are at different distances from the sun. At a distance  $R_s$  from the sun, the solar radiation  $q_{\text{solar}}$  passes through the spherical area  $4\pi R_s^2$ , resulting in a solar heat flux

$$G_s = q_{\text{solar}} / 4\pi R_s^2$$

Continued...

### PROBLEM 12.108 (Cont.)

Thus, knowing the solar irradiation for Earth,  $G_{S,E}$ , we can find the solar irradiation for Venus and Mars:

$$G_{S,V} = G_{S,E} R_{S,E}^2 / R_{S,V}^2 = 1368 \text{ W/m}^2 \times (1.50 \times 10^{11} \text{ m})^2 / (1.08 \times 10^{11} \text{ m})^2 = 2640 \text{ W/m}^2$$

$$G_{S,M} = G_{S,E} R_{S,E}^2 / R_{S,M}^2 = 1368 \text{ W/m}^2 \times (1.50 \times 10^{11} \text{ m})^2 / (2.30 \times 10^{11} \text{ m})^2 = 580 \text{ W/m}^2$$

Finally, the planet temperatures can be calculated:

$$T_{s,E} = \left( \frac{G_{S,E}}{4\sigma} \right)^{1/4} = \left( \frac{1368 \text{ W/m}^2}{4 \times 5.67 \times 10^{-8} \text{ W/m}^2 \cdot \text{K}^4} \right)^{1/4} = 279 \text{ K} \quad <$$

Similarly,

$$T_{s,V} = 329 \text{ K}, \quad T_{s,M} = 225 \text{ K} \quad <$$

The calculated temperatures are compared with the measured average temperatures in the chart:

Planet	$L_{S-p}$ , m	$\bar{T}_p$ , K	$T_{\text{calc}}$ , K
Venus	$1.08 \times 10^{11}$	735	329
Earth	$1.50 \times 10^{11}$	287	279
Mars	$2.30 \times 10^{11}$	227	225

The biggest discrepancy is for Venus, which has a very dense atmosphere and significant radiation absorption, emission and scattering phenomena. <

## PROBLEM 12.109

**KNOWN:** Cavity with window whose outer surface experiences convection and radiation.

**FIND:** Temperature of the window and power required to maintain cavity at prescribed temperature.

**SCHEMATIC:**

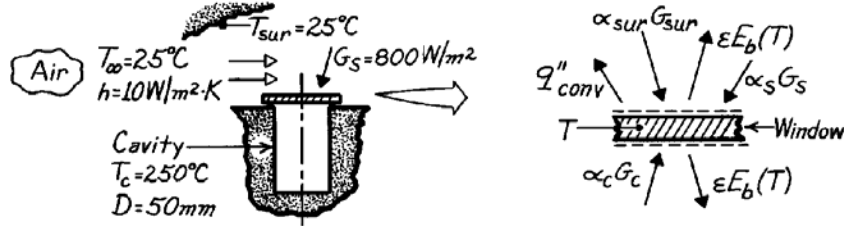

**ASSUMPTIONS:** (1) Steady-state conditions, (2) Cavity behaves as a blackbody, (3) Solar spectral distribution is that of a blackbody at 5800K, (4) Window is isothermal, (5) Negligible convection on lower surface of window.

**PROPERTIES:** Window material:  $0.2 \leq \lambda \leq 4 \mu\text{m}$ ,  $\tau_\lambda = 0.9$ ,  $\rho_\lambda = 0$ , hence  $\alpha_\lambda = 1 - \tau_\lambda = 0.1$ ;  $4 \mu\text{m} < \lambda$ ,  $\tau_\lambda = 0$ ,  $\alpha = \varepsilon = 0.95$ , diffuse-gray, opaque.

**ANALYSIS:** To determine the window temperature, perform an energy balance on the window,

$$\begin{aligned} \dot{E}_{\text{in}} - \dot{E}_{\text{out}} &= 0 \\ [\alpha_{\text{sur}} G_{\text{sur}} + \alpha_S G_S - \varepsilon E_b - q''_{\text{conv}}]_{\text{upper}} + [\alpha_c G_c - \varepsilon E_b(T)]_{\text{lower}} &= 0. \end{aligned} \quad (1)$$

Calculate the absorptivities for various irradiation conditions using Eq. 12.52,

$$\alpha = \int_0^\infty \alpha_\lambda G_\lambda d\lambda / \int_0^\infty G_\lambda d\lambda \quad (2)$$

where  $G(\lambda)$  is the spectral distribution of the irradiation.

*Surroundings,  $\alpha_{\text{sur}}$ :*  $G_{\text{sur}} = E_b(T_{\text{sur}}) = \sigma T_{\text{sur}}^4$

$$\alpha_{\text{sur}} = 0.1 [F_{(0 \rightarrow 4\mu\text{m})} - F_{(0 \rightarrow 0.2\mu\text{m})}] + 0.95 [1 - F_{(0 \rightarrow 4\mu\text{m})}]$$

where from Table 12.1, with  $T = T_{\text{sur}} = (25 + 273)\text{K} = 298\text{K}$ ,

$$\lambda T = 0.2\mu\text{m} \times 298\text{K} = 59.6\mu\text{m} \cdot \text{K}, \quad F_{(0-\lambda T)} = 0.000$$

$$\lambda T = 4\mu\text{m} \times 298\text{K} = 1192\mu\text{m} \cdot \text{K}, \quad F_{(0-\lambda T)} = 0.002$$

$$\alpha_{\text{sur}} = 0.1 [0.002 - 0.000] + 0.95 [1 - 0.002] = 0.948. \quad (3)$$

*Solar,  $\alpha_S$ :*  $G_S \sim E_b(5800\text{K})$

$$\alpha_S = 0.1 [F_{(0 \rightarrow 4\mu\text{m})} - F_{(0 \rightarrow 0.2\mu\text{m})}] + 0.95 [1 - F_{(0 \rightarrow 4\mu\text{m})}]$$

where from Table 12.1, with  $T = 5800\text{K}$ ,

$$\lambda T = 0.2\mu\text{m} \times 5800\text{K} = 1160\mu\text{m} \cdot \text{K}, \quad F_{(0-\lambda T)} = 0.002$$

$$\lambda T = 4\mu\text{m} \times 5800\text{K} = 23,200\mu\text{m} \cdot \text{K}, \quad F_{(0-\lambda T)} = 0.990$$

$$\alpha_S = 0.1 [0.990 - 0.002] + 0.95 [1 - 0.990] = 0.108. \quad (4)$$

Continued ...



**PROBLEM 12.109 (Cont.)**

Cavity,  $\alpha_c$ :  $G_c = E_b(T_c) = \sigma T_c^4$

$$\alpha_c = 0.1 \left[ F_{(0 \rightarrow 4\mu\text{m})} - F_{(0 \rightarrow 0.2\mu\text{m})} \right] + 0.95 \left[ 1 - F_{(0 \rightarrow 4\mu\text{m})} \right]$$

where from Table 12.1 with  $T_c = 250^\circ\text{C} = 523\text{K}$ ,

$$\lambda T = 0.2\mu\text{m} \times 523\text{K} = 104.6\mu\text{m} \cdot \text{K}, \quad F_{0 \rightarrow \lambda T} = 0.000$$

$$\lambda T = 4\mu\text{m} \times 523\text{K} = 2092\mu\text{m} \cdot \text{K} \quad F_{0 \rightarrow \lambda T} = 0.082$$

$$\alpha_c = 0.1[0.082 - 0.000] + 0.95[1 - 0.082] = 0.880. \quad (5)$$

To determine the *emissivity* of the window, we need to know its temperature. However, we know that  $T$  will be less than  $T_c$  and the long wavelength behavior will dominate. That is,

$$\varepsilon \approx \varepsilon_\lambda (\lambda > 4\mu\text{m}) = 0.95. \quad (6)$$

With these radiative properties now known, the energy equation, Eq. (1) can now be evaluated using  $q_{\text{conv}}'' = h(T - T_\infty)$  with all temperatures in kelvin units.

$$0.948 \times \sigma (298\text{K})^4 + 0.108 \times 800 \text{ W/m}^2 - 0.95 \times \sigma T^4 - 10 \text{ W/m}^2 \cdot \text{K} (T - 298\text{K}) + 0.880 \sigma (523\text{K})^4 - 0.95 \times \sigma T^4 = 0$$

$$1.077 \times 10^{-7} T^4 + 10T - 7223 = 0.$$

Using a trial-and-error approach, find the window temperature as

$$T = 413\text{K} = 139^\circ\text{C}.$$

To determine the power required to maintain the cavity at  $T_c = 250^\circ\text{C}$ , perform an energy balance on the cavity.

$$\dot{E}_{\text{in}} - \dot{E}_{\text{out}} = 0$$

$$q_p + A_c [\rho E_b(T_c) + \tau_s G_s + \varepsilon E_b(T) - E_b(T_c)] = 0.$$

For simplicity, we have assumed the window opaque to irradiation from the surroundings. It follows that

$$\tau_s = 1 - \rho_s - \alpha_s = 1 - 0 - 0.108 = 0.892$$

$$\rho = 1 - \alpha = 1 - \varepsilon = 1 - 0.95 = 0.05.$$

Hence, the power required to maintain the cavity, when  $A_c = (\pi/4)D^2$ , is

$$q_p = A_c \left[ \sigma T_c^4 - \rho \sigma T_c^4 - \tau_s G_s - \varepsilon \sigma T^4 \right]$$

$$q_p = \frac{\pi}{4} (0.050\text{m})^2 \left[ \sigma (523\text{K})^4 - 0.05 \sigma (523\text{K})^4 - 0.892 \times 800 \text{ W/m}^2 - 0.95 \sigma (412\text{K})^4 \right]$$

$$q_p = 3.47\text{W}.$$

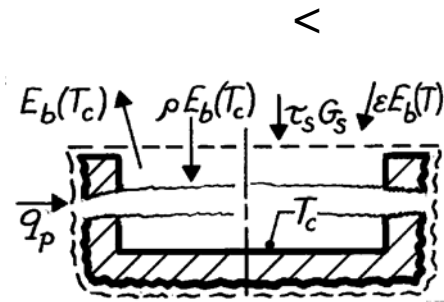

**COMMENTS:** Note that the assumed value of  $\varepsilon = 0.95$  is not fully satisfied. With  $T = 412\text{K}$ , we would expect  $\varepsilon = 0.929$ . Hence, an iteration may be appropriate.

### PROBLEM 12.110

**KNOWN:** Features of an evacuated tube solar collector.

**FIND:** Ideal surface spectral characteristics.

**SCHEMATIC:**

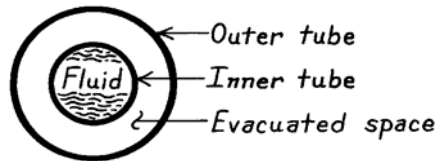

**ANALYSIS:** The outer tube should be transparent to the incident solar radiation, which is concentrated in the spectral region  $\lambda \leq 3\mu\text{m}$ , but it should be opaque and highly reflective to radiation emitted by the outer surface of the inner tube, which is concentrated in the spectral region above  $3\mu\text{m}$ . Accordingly, ideal spectral characteristics for the outer tube are

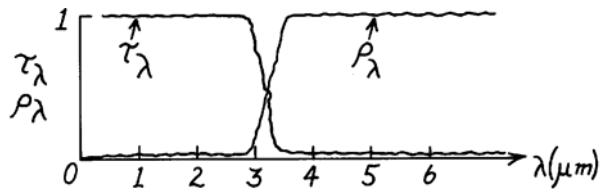

Note that large  $\rho_\lambda$  is desirable for the outer, as well as the inner, surface of the outer tube. If the surface is diffuse, a large value of  $\rho_\lambda$  yields a small value of  $\epsilon_\lambda = \alpha_\lambda = 1 - \rho_\lambda$ . Hence losses due to emission from the outer surface to the surroundings would be negligible.

The opaque outer surface of the inner tube should absorb all of the incident solar radiation ( $\lambda \leq 3\mu\text{m}$ ) and emit little or no radiation, which would be in the spectral region  $\lambda > 3\mu\text{m}$ . Accordingly, assuming diffuse surface behavior, ideal spectral characteristics are:

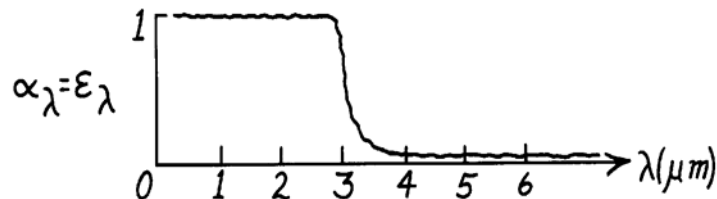

## PROBLEM 12.111

**KNOWN:** Plate exposed to solar flux with prescribed solar absorptivity and emissivity; convection and surrounding conditions also prescribed.

**FIND:** Steady-state temperature of the plate.

**SCHEMATIC:**

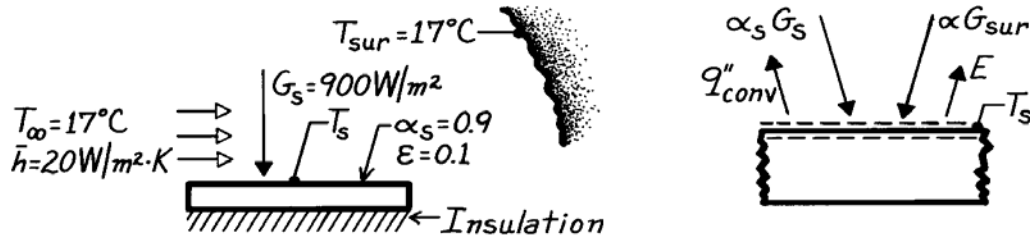

**ASSUMPTIONS:** (1) Steady-state conditions, (2) Plate is small compared to surroundings, (3) Backside of plate is perfectly insulated, (4) Diffuse behavior.

**ANALYSIS:** Perform a surface energy balance on the top surface of the plate.

$$\dot{E}_{\text{in}} - \dot{E}_{\text{out}} = 0$$

$$\alpha_S G_S + \alpha G_{\text{sur}} - q''_{\text{conv}} - \varepsilon E_b(T_S) = 0$$

Note that the effect of the surroundings is to provide an irradiation,  $G_{\text{sur}}$ , on the plate; since the spectral distribution of  $G_{\text{sur}}$  and  $E_{\lambda,b}(T_S)$  are nearly the same, according to Kirchoff's law,  $\alpha = \varepsilon$ .

Recognizing that  $G_{\text{sur}} = \sigma T_{\text{sur}}^4$  and using Newton's law of cooling, the energy balance is

$$\alpha_S G_S + \varepsilon \sigma T_{\text{sur}}^4 - \bar{h}(T_S - T_{\infty}) - \varepsilon \cdot \sigma T_S^4 = 0.$$

Substituting numerical values,

$$\begin{aligned} 0.9 \times 900 \text{ W/m}^2 + 0.1 \times 5.67 \times 10^{-8} \text{ W/m}^2 \cdot \text{K} \times (17 + 273)^4 \text{ K}^4 \\ - 20 \text{ W/m}^2 \cdot \text{K} (T_S - 290) \text{ K} - 0.1 \left( 5.67 \times 10^{-8} \text{ W/m}^2 \cdot \text{K}^4 \right) T_S^4 = 0 \\ 6650 \text{ W/m}^2 = 20 T_S + 5.67 \times 10^{-9} T_S^4. \end{aligned}$$

From a trial-and-error solution, find

$$T_S = 329.2 \text{ K.} \quad \leftarrow$$

**COMMENTS:** (1) When performing an analysis with both convection and radiation processes present, all temperatures must be expressed in absolute units (K).

(2) Note also that the terms  $\alpha G_{\text{sur}} - \varepsilon E_b(T_S)$  could be expressed as a radiation exchange term, written as

$$q''_{\text{rad}} = q/A = \varepsilon \sigma (T_{\text{sur}}^4 - T_S^4).$$

The conditions for application of this relation were met and are namely: surroundings much larger than surface, diffuse surface, and spectral distributions of irradiation and emission are similar (or the surface is gray).

## PROBLEM 12.112

**KNOWN:** Directional distribution of  $\alpha_\theta$  for a horizontal, opaque, gray surface exposed to direct and diffuse irradiation.

**FIND:** (a) Absorptivity to direct radiation at  $45^\circ$  and to diffuse radiation, and (b) Equilibrium temperature for specified direct and diffuse irradiation components.

**SCHEMATIC:**

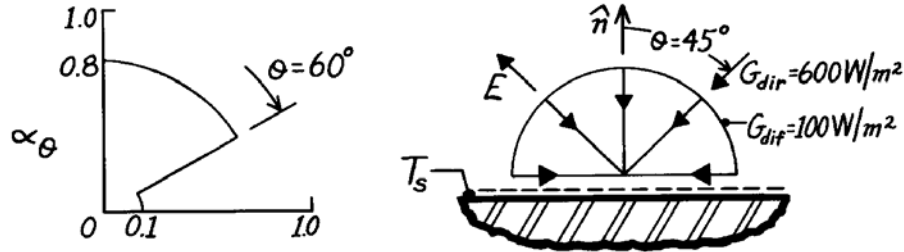

**ASSUMPTIONS:** (1) Steady-state conditions, (2) Opaque, gray surface behavior, (3) Negligible convection at top surface and perfectly insulated back surface.

**ANALYSIS:** (a) From knowledge of  $\alpha_\theta(\theta)$  – see graph above – it is evident that the absorptivity of the surface to the direct radiation ( $45^\circ$ ) is

$$\alpha_{\text{dir}} = \alpha_\theta(45^\circ) = 0.8. \quad <$$

The absorptivity to the diffuse radiation is the hemispherical absorptivity given by Eq. 12.50. Dropping the  $\lambda$  subscript,

$$\alpha_{\text{dir}} = 2 \int_0^{\pi/2} \alpha_\theta(\theta) \cos \theta \sin \theta \, d\theta \quad (1)$$

$$\alpha_{\text{dir}} = 2 \left[ 0.8 \frac{\sin^2 \theta}{2} \Big|_0^{\pi/3} + 0.1 \frac{\sin^2 \theta}{2} \Big|_{\pi/3}^{\pi/2} \right]$$

$$\alpha_{\text{dir}} = 0.625. \quad <$$

(b) Performing a surface energy balance,

$$\dot{E}_{\text{in}}'' - \dot{E}_{\text{out}}'' = 0$$

$$\alpha_{\text{dir}} G_{\text{dir}} + \alpha_{\text{dif}} G_{\text{dif}} - \varepsilon \sigma T_s^4 = 0. \quad (2)$$

The total, hemispherical emissivity may be obtained from Eq. 12.42 where again the subscript may be deleted. Since this equation is of precisely the same form as Eq. 12.50 – see Eq. (1) above – and since  $\alpha_\theta = \varepsilon_\theta$ , it follows that

$$\varepsilon = \alpha_{\text{dif}} = 0.625$$

and from Eq. (2), find

$$T_s^4 = \frac{(0.8 \times 600 + 0.625 \times 100) \text{ W/m}^2}{0.625 \times 5.67 \times 10^{-8} \text{ W/m}^2 \cdot \text{K}^4} = 1.53 \times 10^{10} \text{ K}^4, \quad T_s = 352 \text{ K}. \quad <$$

**COMMENTS:** In assuming *gray* surface behavior, spectral effects are not present, and total and spectral properties are identical. However, the surface is *not diffuse* and hence hemispherical and directional properties differ.

### PROBLEM 12.113

**KNOWN:** Plate temperature and spectral and directional dependence of its absorptivity. Direction and magnitude of solar flux.

**FIND:** (a) Expression for total absorptivity, (b) Expression for total emissivity, (c) Net radiant flux, (d) Effect of cut-off wavelength associated with directional dependence of the absorptivity.

**SCHEMATIC:**

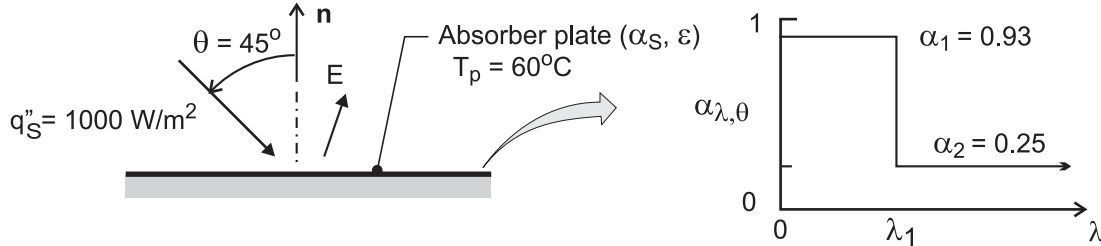

**ASSUMPTIONS:** (1) Diffuse component of solar flux is negligible, (2) Spectral distribution of solar radiation may be approximated as that from a blackbody at 5800 K, (3) Properties are independent of azimuthal angle  $\phi$ .

**ANALYSIS:** (a) For  $\lambda < \lambda_c$  and  $\theta = 45^\circ$ ,  $\alpha_\lambda = \alpha_1 \cos\theta = 0.707 \alpha_1$ . From Eq. 12.53 the total absorptivity is then

$$\alpha_S = 0.707 \alpha_1 \left\{ \frac{\int_0^{\lambda_c} E_{\lambda,b}(\lambda, 5800 \text{ K}) d\lambda}{E_b} \right\} + \alpha_2 \left\{ \frac{\int_{\lambda_c}^{\infty} E_{\lambda,b}(\lambda, 5800 \text{ K}) d\lambda}{E_b} \right\}$$

$$\alpha_S = 0.707 \alpha_1 F_{(0 \rightarrow \lambda_c)} + \alpha_2 [1 - F_{(0 \rightarrow \lambda_c)}] \quad <$$

For the prescribed value of  $\lambda_c$ ,  $\lambda_c T = 11,600 \mu\text{m}\cdot\text{K}$  and, from Table 12.1,  $F_{(0 \rightarrow \lambda_c)} = 0.941$ . Hence,

$$\alpha_S = 0.707 \times 0.93 \times 0.941 + 0.25(1 - 0.941) = 0.619 + 0.015 = 0.634 \quad <$$

(b) With  $\varepsilon_{\lambda,\theta} = \alpha_{\lambda,\theta}$ , Eq 12.42 may be used to obtain  $\varepsilon_\lambda$  for  $\lambda < \lambda_c$ .

$$\varepsilon_\lambda(\lambda, T) = 2\alpha_1 \int_0^{\pi/2} \cos^2 \theta \sin \theta d\theta = -2\alpha_1 \frac{\cos^3 \theta}{3} \Big|_0^{\pi/2} = \frac{2}{3} \alpha_1$$

From Eq. 12.43,

$$\varepsilon = 0.667 \alpha_1 \frac{\int_0^{\lambda_c} E_{\lambda,b}(\lambda, T_p) d\lambda}{E_b} + \alpha_2 \frac{\int_{\lambda_c}^{\infty} E_{\lambda,b}(\lambda, T_p) d\lambda}{E_b}$$

$$\varepsilon = 0.667 \alpha_1 F_{(0 \rightarrow \lambda_c)} + \alpha_2 [1 - F_{(0 \rightarrow \lambda_c)}] \quad <$$

For  $\lambda_c = 2 \mu\text{m}$  and  $T_p = 333 \text{ K}$ ,  $\lambda_c T = 666 \mu\text{m}\cdot\text{K}$  and, from Table 12.1,  $F_{(0 \rightarrow \lambda_c)} = 0$ . Hence,

$$\varepsilon = \alpha_2 = 0.25 \quad <$$

Continued ...

**PROBLEM 12.113 (Cont.)**

$$(c) \quad q''_{\text{net}} = \alpha_S q''_S - \varepsilon \sigma T_p^4 = 634 \text{ W/m}^2 - 0.25 \times 5.67 \times 10^{-8} \text{ W/m}^2 \cdot \text{K}^4 (333 \text{ K})^4$$

$$q''_{\text{net}} = 460 \text{ W/m}^2$$

<

(d) Using the foregoing model with the Radiation/Band Emission Factor option of *IHT*, the following results were obtained for  $\alpha_S$  and  $\varepsilon$ . The absorptivity increases with increasing  $\lambda_c$ , as more of the incident solar radiation falls within the region of  $\alpha_1 > \alpha_2$ . Note, however, the limit at  $\lambda \approx 3 \mu\text{m}$ , beyond which there is little change in  $\alpha_S$ . The emissivity also increases with increasing  $\lambda_c$ , as more of the emitted radiation is at wavelengths for which  $\varepsilon_1 = \alpha_1 > \varepsilon_2 = \alpha_2$ . However, the surface temperature is low, and even for  $\lambda_c = 5 \mu\text{m}$ , there is little emission at  $\lambda < \lambda_c$ . Hence,  $\varepsilon$  only increases from 0.25 to 0.26 as  $\lambda_c$  increases from 0.7 to 5.0  $\mu\text{m}$ .

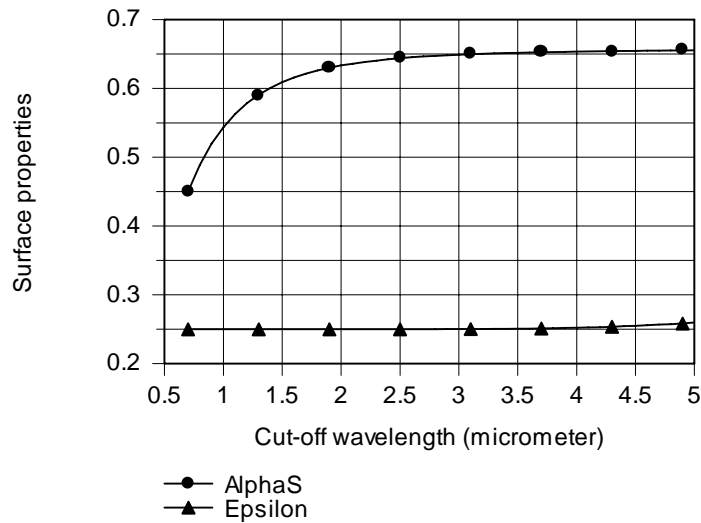

The net heat flux increases from  $276 \text{ W/m}^2$  at  $\lambda_c = 2 \mu\text{m}$  to a maximum of  $477 \text{ W/m}^2$  at  $\lambda_c = 4.2 \mu\text{m}$  and then decreases to  $474 \text{ W/m}^2$  at  $\lambda_c = 5 \mu\text{m}$ . The existence of a maximum is due to the upper limit on the value of  $\alpha_S$  and the increase in  $\varepsilon$  with  $\lambda_c$ .

**COMMENTS:** Spectrally and directionally selective coatings may be used to enhance the performance of solar collectors.

### PROBLEM 12.114

**KNOWN:** Spectral distribution of  $\alpha_\lambda$  for two roof coatings.

**FIND:** Preferred coating for summer and winter use. Ideal spectral distribution of  $\alpha_\lambda$ .

**SCHEMATIC:**

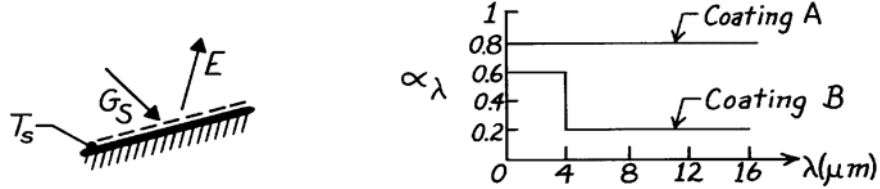

**ASSUMPTIONS:** (1) Opaque, diffuse surface behavior, (2) Negligible convection effects and heat transfer from bottom of roof, negligible atmospheric irradiation, (3) Steady-state conditions.

**ANALYSIS:** From an energy balance on the roof surface

$$\varepsilon \sigma T_s^4 = \alpha_S G_S.$$

Hence

$$T_s = \left( \frac{\alpha_S G_S}{\varepsilon \sigma} \right)^{1/4}.$$

Solar irradiation is concentrated in the spectral region  $\lambda < 4\mu\text{m}$ , while surface emission is concentrated in the region  $\lambda > 4\mu\text{m}$ . Hence, with  $\alpha_\lambda = \varepsilon_\lambda$

$$\text{Coating A:} \quad \alpha_S \approx 0.8, \quad \varepsilon \approx 0.8$$

$$\text{Coating B:} \quad \alpha_S \approx 0.6, \quad \varepsilon \approx 0.2.$$

Since  $(\alpha_S/\varepsilon)_A = 1 < (\alpha_S/\varepsilon)_B = 3$ , Coating A would result in the lower roof temperature and is preferred for summer use. In contrast, Coating B is preferred for winter use. The ideal coating is one which minimizes  $(\alpha_S/\varepsilon)$  in the summer and maximizes it in the winter.

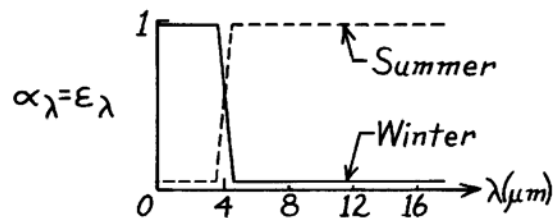

## PROBLEM 12.115

**KNOWN:** Shallow pan of water exposed to night desert air and sky conditions.

**FIND:** Whether water will freeze.

**SCHEMATIC:**

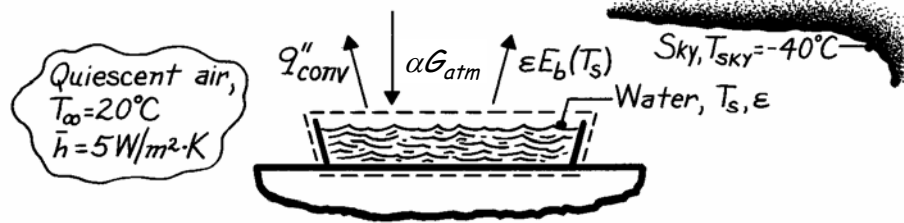

**ASSUMPTIONS:** (1) Steady-state conditions, (2) Bottom of pan is well insulated, (3) Water surface is diffuse-gray, (4) Sky provides blackbody irradiation,  $G_{\text{atm}} = \sigma T_{\text{sky}}^4$ .

**PROPERTIES:** Table A-11, Water (300 K):  $\epsilon = 0.96$ .

**ANALYSIS:** To estimate the water surface temperature for these conditions, begin by performing an energy balance on the pan of water considering convection and radiation processes.

$$\begin{aligned}\dot{E}_{\text{in}}'' - \dot{E}_{\text{out}}'' &= 0 \\ \alpha G_{\text{atm}} - \epsilon E_b - \bar{h}(T_s - T_\infty) &= 0 \\ \epsilon \sigma (T_{\text{sky}}^4 - T_s^4) - \bar{h}(T_s - T_\infty) &= 0.\end{aligned}$$

Note that, from Eq. 12.73,  $G_{\text{atm}} = \sigma T_{\text{sky}}^4$  and from Assumption 3,  $\alpha = \epsilon$ . Substituting numerical values, with all temperatures in kelvin units, the energy balance is

$$\begin{aligned}0.96 \times 5.67 \times 10^{-8} \frac{\text{W}}{\text{m}^2 \cdot \text{K}^4} \left[ (-40 + 273)^4 - T_s^4 \right] \text{K}^4 - 5 \frac{\text{W}}{\text{m}^2 \cdot \text{K}} \left[ T_s - (20 + 273) \right] \text{K} &= 0 \\ 5.443 \times 10^{-8} \left[ 233^4 - T_s^4 \right] - 5 \left[ T_s - 293 \right] &= 0.\end{aligned}$$

Using a trial-and-error approach, find the water surface temperature,

$$T_s = 268.5 \text{ K.} \quad <$$

Since  $T_s < 273 \text{ K}$ , it follows that the water surface will freeze under the prescribed air and sky conditions.

**COMMENTS:** If the heat transfer coefficient were to increase as a consequence of wind, freezing might not occur. Verify that for the given  $T_\infty$  and  $T_{\text{sky}}$ , that if  $\bar{h}$  increases by more than 40%, freezing cannot occur.



## PROBLEM 12.116

**KNOWN:** Environmental conditions associated with a corn leaf, evaporative fluxes in rural and urban settings due to differences in ambient CO<sub>2</sub> concentrations, absorptivity and emissivity values.

**FIND:** Leaf temperature for high (urban) and low (rural) ambient CO<sub>2</sub> concentrations.

**SCHEMATIC:**

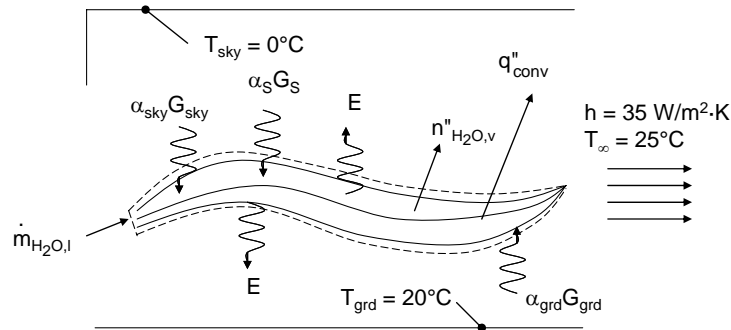

**PROPERTIES:** (Given)  $h_{fg} = 2400 \text{ kJ/kg}$ .

**ASSUMPTIONS:** (1) Steady state conditions, (2) Ground and sky represent large surroundings, (3) Negligible irradiation from other leaves, (4)  $\alpha = \varepsilon$  for radiation at long wavelengths, (5) Evaporation flux on top and bottom of leaf.

**ANALYSIS:** Performing an energy balance on the leaf on a per unit area basis,

$$\alpha_s G_s + \alpha_{\text{sky}} \sigma T_{\text{sky}}^4 + \alpha_{\text{grd}} \sigma T_{\text{grd}}^4 = 2h(T - T_{\infty}) + 2\varepsilon \sigma T^4 + 2n''_{\text{H}_2\text{O}} h_{fg}$$

Substituting values for the lower CO<sub>2</sub> environment, high evaporation rate (rural) case,

$$\begin{aligned} &0.76 \times 600 \text{ W/m}^2 + 0.97 \times 5.67 \times 10^{-8} \text{ W/m}^2 \cdot \text{K}^4 \times (273 + 0)^4 \text{ K}^4 + 0.97 \times 5.67 \times 10^{-8} \text{ W/m}^2 \cdot \text{K}^4 \times (273 + 20)^4 \text{ K}^4 \\ &= \\ &2 \times 35 \text{ W/m}^2 \cdot \text{K} \times [T - (273 + 25)] \text{ K} \\ &+ 2 \times 0.97 \times 5.67 \times 10^{-8} \text{ W/m}^2 \cdot \text{K}^4 \times (T)^4 \text{ K}^4 + 2 \times 50 \times 10^{-6} \text{ kg/m}^2 \cdot \text{s} \times 2400 \times 10^3 \text{ J/kg} \end{aligned}$$

which yields  $T = 298.7 \text{ K} = 25.7^\circ\text{C}$  <

Substituting  $n''_{\text{H}_2\text{O}} = 5 \times 10^{-6} \text{ kg/s}$  for the low evaporation (urban) case yields  $T = 301.4 \text{ K} = 28.4^\circ\text{C}$  <

**COMMENTS:** (1) Carbon dioxide levels in urban areas can easily be more than three times greater than in rural communities due to, primarily, fossil fuel combustion corresponding to high traffic density. The sensitivity of the leaf temperature to the local CO<sub>2</sub> concentration is significant. (2) Reduced leaf evaporation rates associated with the higher CO<sub>2</sub> concentration makes corn and other so-called C4 photosynthesis plants more drought-tolerant in urban areas. See, for example, Wall et al., "Elevated Atmospheric CO<sub>2</sub> Improved Sorghum Plant Water Status by Ameliorating the Adverse Effects of Drought," *New Phytologist*, Vol. 152, pp. 231 – 248, 2001. (3) Higher rates of respiratory ailments in urban versus rural communities have been attributed to increased pollen production by plants such as ragweed in cities. The increased pollen production is associated with the increased drought tolerance of ragweed due to elevated CO<sub>2</sub> levels. See L.H. Ziska et al., "Cities as Harbingers of Climate Change: Common Ragweed, Urbanization, and Public Health," *Journal of Allergy and Clinical Immunology*, Vol. 111, pp. 290 - 295, 2003.

## PROBLEM 12.117

**KNOWN:** Thermal conductivity, spectral absorptivity and inner and outer surface conditions for wall of central solar receiver.

**FIND:** Minimum wall thickness needed to prevent thermal failure. Collector efficiency.

**SCHEMATIC:**

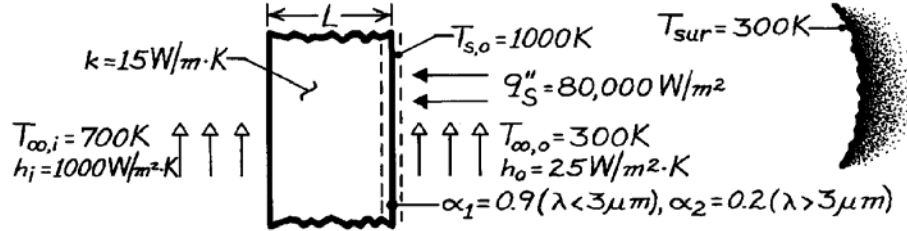

**ASSUMPTIONS:** (1) Steady-state conditions, (2) Outer surface is opaque and diffuse, (3) Spectral distribution of solar radiation corresponds to blackbody emission at 5800 K.

**ANALYSIS:** From an energy balance at the outer surface,  $\dot{E}_{in} = \dot{E}_{out}$ ,

$$\alpha_S q_S'' + \alpha_{sur} G_{sur} = \varepsilon \sigma T_{s,o}^4 + h_o (T_{s,o} - T_{\infty,o}) + \frac{T_{s,o} - T_{\infty,i}}{(L/k) + (1/h_i)}$$

Since radiation from the surroundings is in the far infrared,  $\alpha_{sur} = 0.2$ . From Table 12.1,  $\lambda T = (3 \mu m \times 5800 \text{ K}) = 17,400 \mu m \cdot K$ , find  $F_{(0 \rightarrow 3 \mu m)} = 0.979$ . Hence,

$$\alpha_s = \frac{\int_0^{\infty} \alpha_\lambda E_{\lambda,b}(5800 \text{ K}) d\lambda}{E_b} = \alpha_1 F_{(0 \rightarrow 3 \mu m)} + \alpha_2 F_{(3 \rightarrow \infty)} = 0.9(0.979) + 0.2(0.021) = 0.885.$$

From Table 12.1,  $\lambda T = (3 \mu m \times 1000 \text{ K}) = 3000 \mu m \cdot K$ , find  $F_{(0 \rightarrow 3 \mu m)} = 0.273$ . Hence,

$$\varepsilon_s = \frac{\int_0^{\infty} \varepsilon_\lambda E_{\lambda,b}(1000 \text{ K}) d\lambda}{E_b} = \varepsilon_1 F_{(0 \rightarrow 3)} + \varepsilon_2 F_{(3 \rightarrow \infty)} = 0.9(0.273) + 0.2(0.727) = 0.391.$$

Substituting numerical values in the energy balance, find

$$0.885 \left( 80,000 \text{ W/m}^2 \right) + 0.2 \times 5.67 \times 10^{-8} \text{ W/m}^2 \cdot \text{K}^4 (300 \text{ K})^4 = 0.391 \times 5.67 \times 10^{-8} \text{ W/m}^2 \cdot \text{K}^4 (1000 \text{ K})^4 + 25 \text{ W/m}^2 \cdot \text{K} (700 \text{ K}) + (300 \text{ K}) \left[ (L/15 \text{ W/m} \cdot \text{K}) + (1/1000 \text{ W/m}^2 \cdot \text{K}) \right]$$

$$L = 0.129 \text{ m.} \quad <$$

The corresponding collector efficiency is

$$\eta = \frac{q_{use}''}{q_S''} = \left[ \frac{T_{s,o} - T_{\infty,i}}{(L/k) + (1/h_i)} \right] / q_S''$$

$$\eta = \left[ \frac{300 \text{ K}}{(0.129 \text{ m}/15 \text{ W/m} \cdot \text{K}) + (0.001 \text{ m}^2 \cdot \text{K}/\text{W})} \right] / 80,000 \text{ W/m}^2 = 0.391 \text{ or } 39.1\%. \quad <$$

**COMMENTS:** The collector efficiency could be increased and the outer surface temperature reduced by decreasing the value of L.

## PROBLEM 12.118

**KNOWN:** Dimensions, spectral absorptivity, and temperature of solar receiver. Solar irradiation and ambient temperature.

**FIND:** (a) Rate of energy collection  $q$  and collector efficiency  $\eta$ , (b) Effect of receiver temperature on  $q$  and  $\eta$ .

**SCHEMATIC:**

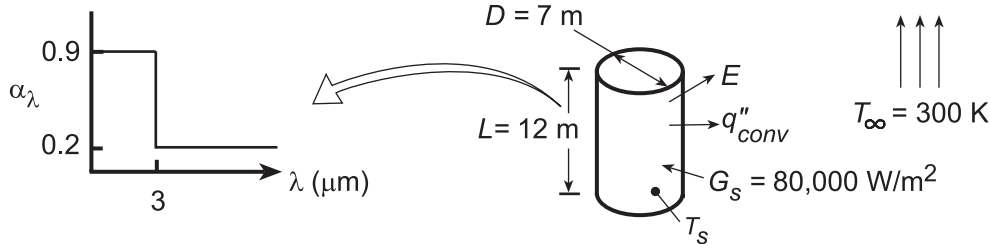

**ASSUMPTIONS:** (1) Steady-state, (2) Uniform irradiation, (3) Opaque, diffuse surface.

**PROPERTIES:** Table A.4, air ( $T_f = 550$  K):  $\nu = 45.6 \times 10^{-6}$  m<sup>2</sup>/s,  $k = 0.0439$  W/m·K,  $\alpha = 66.7 \times 10^{-6}$  m<sup>2</sup>/s,  $Pr = 0.683$ .

**ANALYSIS:** (a) The rate of heat transfer to the receiver is  $q = A_s (\alpha_S G_S - E - q''_{conv})$ , or

$$q = \pi DL \left[ \alpha_S G_S - \varepsilon \sigma T_s^4 - \bar{h} (T_s - T_\infty) \right]$$

For  $\lambda T = 3 \mu\text{m} \times 5800 \text{ K} = 17,400$ ,  $F_{(0 \rightarrow \lambda)} = 0.979$ . Hence,

$$\alpha_S = \alpha_1 F_{(0 \rightarrow \lambda)} + \alpha_2 (1 - F_{(0 \rightarrow \lambda)}) = 0.9 \times 0.979 + 0.2(0.021) = 0.885$$

For  $\lambda T = 3 \mu\text{m} \times 800 \text{ K} = 2400 \mu\text{m} \cdot \text{K}$ ,  $F_{(0 \rightarrow \lambda)} = 0.140$ . Hence,

$$\varepsilon = \varepsilon_1 F_{(0 \rightarrow \lambda)} + \varepsilon_2 (1 - F_{(0 \rightarrow \lambda)}) = 0.9 \times 0.140 + 0.2(0.860) = 0.298.$$

With  $Ra_L = g\beta(T_s - T_\infty)L^3/\alpha\nu = 9.8 \text{ m/s}^2(1/550 \text{ K})(500 \text{ K})(12 \text{ m})^3/66.7 \times 10^{-6} \text{ m}^2/\text{s} \times 45.6 \times 10^{-6} \text{ m}^2/\text{s} = 5.06 \times 10^{12}$ , Eq. 9.26 yields

$$\overline{Nu}_L = \left\{ 0.825 + \frac{0.387 Ra_L^{1/6}}{\left[ 1 + (0.492/Pr)^{9/16} \right]^{8/27}} \right\}^2 = 1867$$

$$\bar{h} = \overline{Nu}_L \frac{k}{L} = 1867 \frac{0.0439 \text{ W/m} \cdot \text{K}}{12 \text{ m}} = 6.83 \text{ W/m}^2 \cdot \text{K}$$

Hence,

$$q = \pi (7 \text{ m} \times 12 \text{ m}) \left[ 0.885 \times 80,000 \text{ W/m}^2 - 0.298 \times 5.67 \times 10^{-8} \text{ W/m}^2 \cdot \text{K}^4 (800 \text{ K})^4 - 6.83 \text{ W/m}^2 \cdot \text{K} (500 \text{ K}) \right]$$

$$q = 263.9 \text{ m}^2 (70,800 - 6,920 - 3415) \text{ W/m}^2 = 1.60 \times 10^7 \text{ W} \quad <$$

The collector efficiency is  $\eta = q/A_s G_S$ . Hence

$$\eta = \frac{1.60 \times 10^7 \text{ W}}{263.9 \text{ m}^2 (80,000 \text{ W/m}^2)} = 0.758 \quad <$$

Continued ...

### PROBLEM 12.118 (Cont.)

(b) The IHT *Correlations, Properties* and *Radiation* Toolpads were used to obtain the following results.

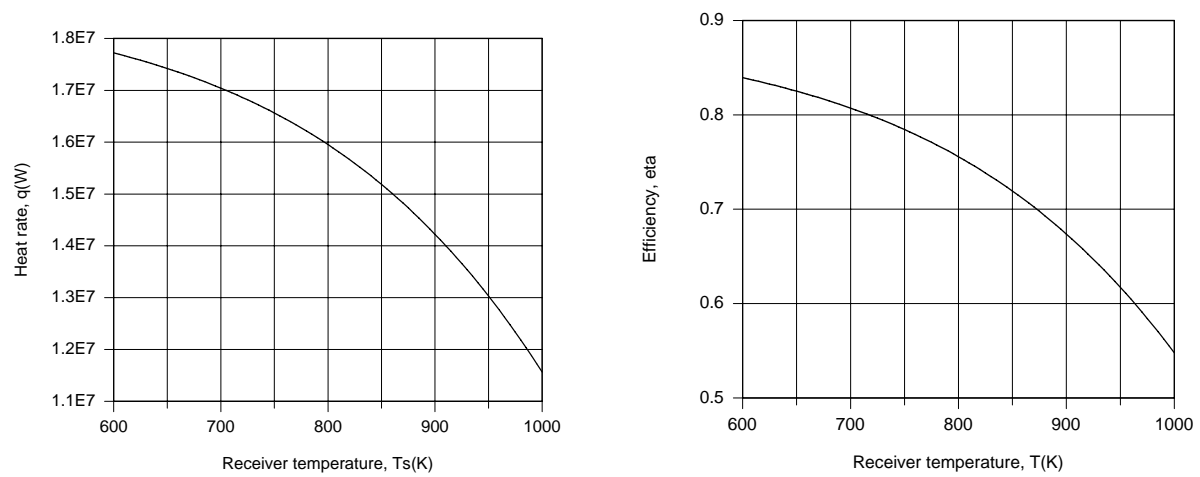

Losses due to emission and convection increase with increasing  $T_s$ , thereby reducing  $q$  and  $\eta$ .

**COMMENTS:** The increase in radiation emission is due to the increase in  $T_s$ , as well as to the effect of  $T_s$  on  $\epsilon$ , which increases from 0.228 to 0.391 as  $T_s$  increases from 600 to 1000 K.

## PROBLEM 12.119

**KNOWN:** Flat plate exposed to night sky and in ambient air at  $T_{\text{air}} = 15^\circ\text{C}$  with a relative humidity of 70%. Radiation from the atmosphere or sky estimated as a fraction of the blackbody radiation corresponding to the near-ground air temperature,  $G_{\text{sky}} = \epsilon_{\text{sky}} \sigma T_{\text{air}}$ , and for a clear night,  $\epsilon_{\text{sky}} = 0.741 + 0.0062 T_{\text{dp}}$  where  $T_{\text{dp}}$  is the dew point temperature ( $^\circ\text{C}$ ). Convection coefficient estimated by correlation,  $\bar{h} (\text{W} / \text{m}^2 \cdot \text{K}) = 1.25 \Delta T^{1/3}$  where  $\Delta T$  is the plate-to-air temperature difference (K).

**FIND:** Whether dew will form on the plate if the surface is (a) clean metal with  $\epsilon_m = 0.23$  and (b) painted with  $\epsilon_p = 0.85$ .

**SCHEMATIC:**

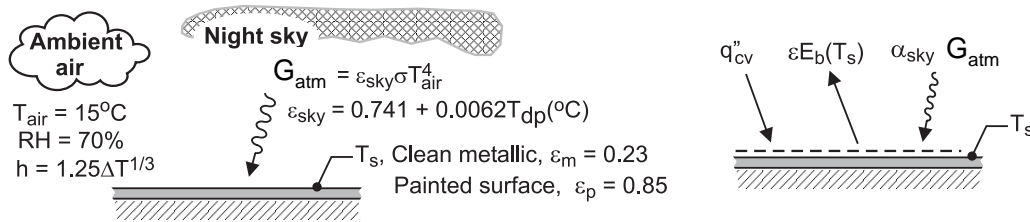

**ASSUMPTIONS:** (1) Steady-state conditions, (2) Surfaces are diffuse, gray, and (3) Backside of plate is well insulated.

**PROPERTIES:** *Psychrometric charts* (Air),  $T_{\text{dp}} = 9.4^\circ\text{C}$  for dry bulb temperature  $15^\circ\text{C}$  and relative humidity 70%.

**ANALYSIS:** From the schematic above, the energy balance on the plate is

$$\dot{E}_{\text{in}}'' - \dot{E}_{\text{out}}'' = 0$$

$$\alpha_{\text{sky}} G_{\text{atm}} + q_{\text{cv}}'' - \epsilon E_b(T_s) = 0$$

$$\epsilon \left[ \left( 0.741 + 0.0062 T_{\text{dp}} (^\circ\text{C}) \right) \sigma T_{\text{air}}^4 \right] + 1.25 (T_{\text{air}} - T_s)^{4/3} \text{ W} / \text{m}^2 - \epsilon \sigma T_s^4 \text{ W} / \text{m}^2 = 0$$

where  $G_{\text{atm}} = \epsilon_{\text{sky}} \sigma T_{\text{air}}$ ,  $\epsilon_{\text{sky}} = 0.741 + 0.062 T_{\text{dp}} (^\circ\text{C})$ ;  $T_{\text{dp}}$  has units ( $^\circ\text{C}$ ); and, other temperatures in kelvins. Since the surface is diffuse-gray,  $\alpha_{\text{sky}} = \epsilon$ .

(a) *Clean metallic surface*,  $\epsilon_m = 0.23$

$$0.23 \left[ \left( 0.741 + 0.0062 T_{\text{dp}} (^\circ\text{C}) \right) \sigma (15 + 273)^4 \text{ K}^4 \right] + 1.25 (289 - T_{\text{s,m}})^{4/3} \text{ W} / \text{m}^2 - 0.23 \sigma T_{\text{s,m}}^4 \text{ W} / \text{m}^2 = 0$$

$$T_{\text{s,m}} = 282.7 \text{ K} = 9.7^\circ\text{C} \quad <$$

(b) *Painted surface*,  $\epsilon_p = 0.85$   $T_{\text{s,p}} = 278.5 \text{ K} = 5.5^\circ\text{C}$  <

**COMMENTS:** For the painted surface,  $\epsilon_p = 0.85$ , find that  $T_s < T_{\text{dp}}$ , so we expect dew formation. For the clean, metallic surface,  $T_s > T_{\text{dp}}$ , so we do not expect dew formation.

## PROBLEM 12.120

**KNOWN:** Glass sheet, used on greenhouse roof, is subjected to solar flux,  $G_S$ , atmospheric emission,  $G_{atm}$ , and interior surface emission,  $G_i$ , as well as to convection processes.

**FIND:** (a) Appropriate energy balance for a unit area of the glass, (b) Temperature of the greenhouse ambient air,  $T_{\infty,i}$ , for prescribed conditions.

**SCHEMATIC:**

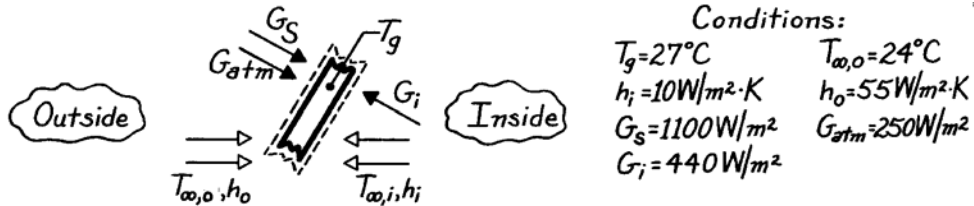

**ASSUMPTIONS:** (1) Glass is at a uniform temperature,  $T_g$ , (2) Steady-state conditions.

**PROPERTIES:** Glass:  $\tau_\lambda = 1$  for  $\lambda \leq 1\mu\text{m}$ ;  $\tau_\lambda = 0$  and  $\alpha_\lambda = 1$  for  $\lambda > 1\mu\text{m}$ .

**ANALYSIS:** (a) Performing an energy balance on the glass sheet with  $\dot{E}_{in} - \dot{E}_{out} = 0$  and considering two convection processes, emission and three absorbed irradiation terms, find

$$\alpha_S G_S + \alpha_{atm} G_{atm} + h_o (T_{\infty,o} - T_g) + \alpha_i G_i + h_i (T_{\infty,i} - T_g) - 2\varepsilon \sigma T_g^4 = 0 \quad (1)$$

where

$\alpha_S =$  solar absorptivity for absorption of  $G_{\lambda,S} \sim E_{\lambda,b}(\lambda, 5800\text{K})$

$\alpha_{atm} = \alpha_i =$  absorptivity of long wavelength irradiation ( $\lambda \gg 1\mu\text{m}$ )  $\approx 1$

$\varepsilon = \alpha_\lambda$  for  $\lambda \gg 1\mu\text{m}$ , emissivity for long wavelength emission  $\approx 1$

(b) For the prescribed conditions,  $T_{\infty,i}$  can be evaluated from Eq. (1). As noted above,  $\alpha_{atm} = \alpha_i = 1$  and  $\varepsilon = 1$ . The solar absorptivity of the glass follows from Eq. 12.53 where  $G_{\lambda,S} \sim E_{\lambda,b}(\lambda, 5800\text{K})$ ,

$$\alpha_S = \int_0^\infty \alpha_\lambda G_{\lambda,S} d\lambda / G_S = \int_0^\infty \alpha_\lambda E_{\lambda,b}(\lambda, 5800\text{K}) d\lambda / E_b(5800\text{K})$$

$$\alpha_S = \alpha_1 F_{(0 \rightarrow 1\mu\text{m})} + \alpha_2 [1 - F_{(0 \rightarrow 1\mu\text{m})}] = 0 \times 0.720 + 1.0 [1 - 0.720] = 0.28.$$

Note that from Table 12.1 for  $\lambda T = 1\mu\text{m} \times 5800\text{K} = 5800\mu\text{m}\cdot\text{K}$ ,  $F_{(0-\lambda)} = 0.720$ . Substituting numerical values into Eq. (1),

$$0.28 \times 1100 \text{ W/m}^2 + 1 \times 250 \text{ W/m}^2 + 55 \text{ W/m}^2 \cdot \text{K} (24 - 27) \text{ K} + 1 \times 440 \text{ W/m}^2 + 10 \text{ W/m}^2 \cdot \text{K} (T_{\infty,i} - 27) \text{ K} - 2 \times 1 \times 5.67 \times 10^{-8} \text{ W/m}^2 \cdot \text{K} (27 + 273)^4 \text{ K}^4 = 0$$

find that

$$T_{\infty,i} = 35.5^\circ\text{C}.$$

<

## PROBLEM 12.121

**KNOWN:** Plate temperature and spectral absorptivity of coating.

**FIND:** (a) Solar irradiation, (b) Effect of solar irradiation on plate temperature, total absorptivity, and total emissivity.

**SCHEMATIC:**

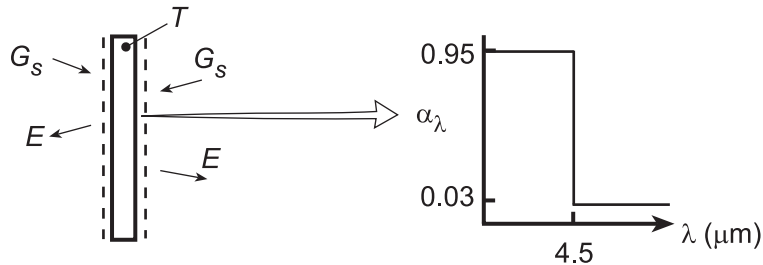

**ASSUMPTIONS:** (1) Steady-state, (2) Opaque, diffuse surface, (3) Isothermal plate, (4) Negligible radiation from surroundings.

**ANALYSIS:** (a) Performing an energy balance on the plate,  $2\alpha_S G_S - 2E = 0$  and

$$\alpha_S G_S - \varepsilon \sigma T^4 = 0$$

For  $\lambda T = 4.5 \mu\text{m} \times 2000 \text{K} = 9000 \mu\text{m}\cdot\text{K}$ , Table 12.1 yields  $F_{(0 \rightarrow \lambda)} = 0.890$ . Hence,

$$\varepsilon = \varepsilon_1 F_{(0 \rightarrow \lambda)} + \varepsilon_2 (1 - F_{(0 \rightarrow \lambda)}) = 0.95 \times 0.890 + 0.03(1 - 0.890) = 0.849$$

For  $\lambda T = 4.5 \mu\text{m} \times 5800 \text{K} = 26,100$ ,  $F_{(0 \rightarrow \lambda)} = 0.993$ . Hence,

$$\alpha_S = \alpha_1 F_{(0 \rightarrow \lambda)} + \alpha_2 (1 - F_{(0 \rightarrow \lambda)}) = 0.95 \times 0.993 + 0.03 \times 0.007 = 0.944$$

Hence,

$$G_S = (\varepsilon / \alpha_S) \sigma T^4 = (0.849 / 0.944) 5.67 \times 10^{-8} \text{W/m}^2 \cdot \text{K}^4 (2000 \text{K})^4 = 8.16 \times 10^5 \text{W/m}^2 <$$

(b) Using the IHT *First Law Model* and the *Radiation Toolpad*, the following results were obtained.

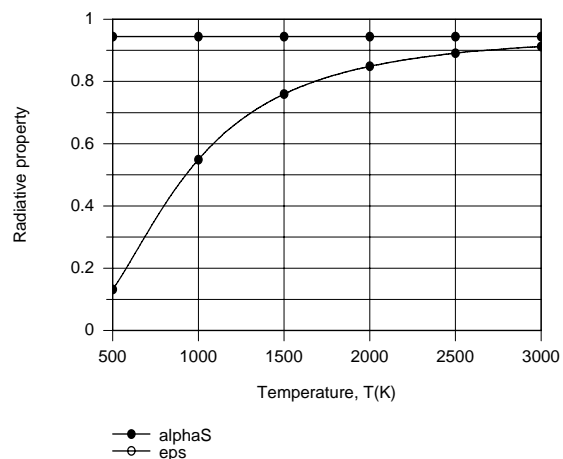
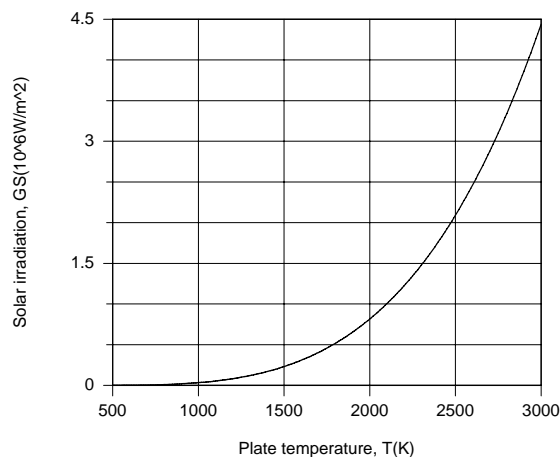

The required solar irradiation increases with  $T$  to the fourth power. Since  $\alpha_S$  is determined by the spectral distribution of solar radiation, its value is fixed. However, with increasing  $T$ , the spectral distribution of emission is shifted to lower wavelengths, thereby increasing the value of  $\varepsilon$ .

## PROBLEM 12.122

**KNOWN:** Dimensions and construction of truck roof. Roof interior surface temperature. Truck speed, ambient air temperature, and solar irradiation.

**FIND:** (a) Preferred roof coating, (b) Roof surface temperature, (c) Heat load through roof, (d) Effect of velocity on surface temperature and heat load.

**SCHEMATIC:**

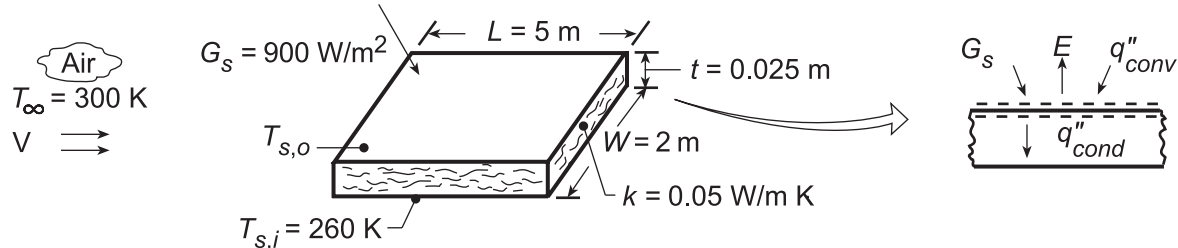

**ASSUMPTIONS:** (1) Turbulent boundary layer development over entire roof, (2) Constant properties, (3) Negligible atmospheric (sky) irradiation, (4) Negligible contact resistance.

**PROPERTIES:** Table A.4, Air ( $T_{s,o} \approx 300$  K, 1 atm):  $\nu = 15 \times 10^{-6} \text{ m}^2/\text{s}$ ,  $k = 0.026 \text{ W/m}\cdot\text{K}$ ,  $\text{Pr} = 0.71$ .

**ANALYSIS:** (a) To minimize heat transfer through the roof, minimize solar absorption relative to surface emission. Hence, use zinc oxide white for which  $\alpha_S = 0.16$  and  $\varepsilon = 0.93$ . (Table A.12) <

(b) Performing an energy balance on the outer surface of the roof,  $\alpha_S G_S + q''_{\text{conv}} - E - q''_{\text{cond}} = 0$ , it follows that

$$\alpha_S G_S + \bar{h}(T_{\infty} - T_{s,o}) = \varepsilon \sigma T_{s,o}^4 + (k/t)(T_{s,o} - T_{s,i})$$

where it is assumed that convection is from the air to the roof. With an analysis based upon the content of Chapter 7

$$\text{Re}_L = \frac{VL}{\nu} = \frac{30 \text{ m/s}(5 \text{ m})}{15 \times 10^{-6} \text{ m}^2/\text{s}} = 10^7$$

$$\overline{\text{Nu}}_L = 0.037 \text{Re}_L^{4/5} \text{Pr}^{1/3} = 0.037(10^7)^{4/5} (0.71)^{1/3} = 13,141$$

$$\bar{h} = \overline{\text{Nu}}_L (k/L) = 13,141(0.026 \text{ W/m}\cdot\text{K}/5 \text{ m}) = 68.3 \text{ W/m}^2\cdot\text{K}.$$

Substituting numerical values in the energy balance and solving by trial-and-error, we obtain

$$T_{s,o} = 295.2 \text{ K}. \quad <$$

(c) The heat load through the roof is

$$q = (kA_S/t)(T_{s,o} - T_{s,i}) = (0.05 \text{ W/m}\cdot\text{K} \times 10 \text{ m}^2 / 0.025 \text{ m}) 35.2 \text{ K} = 704 \text{ W}. \quad <$$

(d) Using the IHT *First Law Model* with the *Correlations* and *Properties* Toolpads, the following results are obtained.

Continued...



### PROBLEM 12.122 (Cont.)

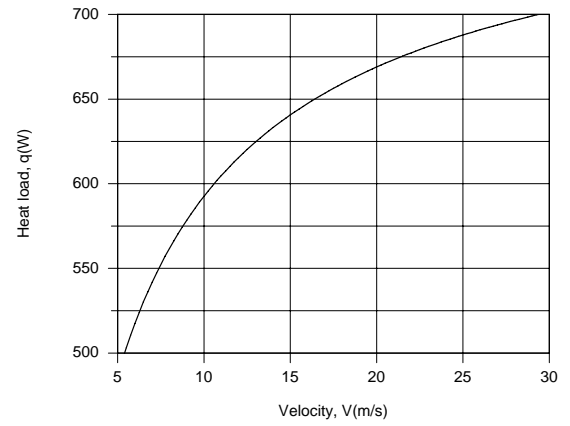
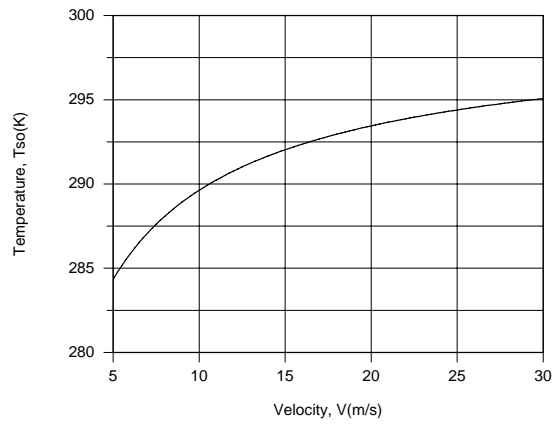

The surface temperature and heat load decrease with decreasing  $V$  due to a reduction in the convection heat transfer coefficient and hence convection heat transfer from the air.

**COMMENTS:** The heat load would increase with increasing  $\alpha_s/\epsilon$ .

### PROBLEM 12.123

**KNOWN:** Sky, ground, and ambient air temperatures. Grape of prescribed diameter and properties.

**FIND:** (a) General expression for rate of change of grape temperature, (b) Whether grapes will freeze in quiescent air, (c) Whether grapes will freeze for a prescribed air speed.

**SCHEMATIC:**

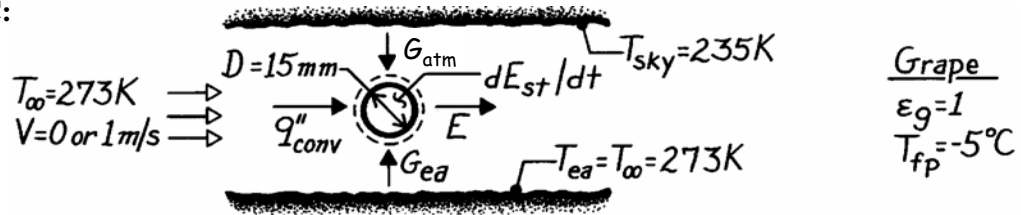

**ASSUMPTIONS:** (1) Negligible temperature gradients in grape, (2) Uniform blackbody irradiation over top and bottom hemispheres, (3) Properties of grape are those of water at 273 K, (4) Properties of air are constant at values for  $T_\infty$ , (5) Negligible buoyancy for  $V = 1$  m/s.

**PROPERTIES:** Table A-6, Water (273 K):  $c_p = 4217$  J/kg·K,  $\rho = 1000$  kg/m<sup>3</sup>; Table A-4, Air (273 K, 1 atm):  $\nu = 13.49 \times 10^{-6}$  m<sup>2</sup>/s,  $k = 0.0241$  W/m·K,  $\alpha = 18.9 \times 10^{-6}$  m<sup>2</sup>/s,  $Pr = 0.714$ ,  $\beta = 3.66 \times 10^{-3}$  K<sup>-1</sup>.

**ANALYSIS:** (a) Performing an energy balance for a control surface about the grape,

$$\frac{dE_{st}}{dt} = \rho_g \frac{\pi D^3}{6} c_{p,g} \frac{dT_g}{dt} = \bar{h} \pi D^2 (T_\infty - T_g) + \frac{\pi D^2}{2} (G_{ea} + G_{atm}) - E \pi D^2.$$

where  $G_{atm} = \sigma T_{sky}^4$ . Hence, the rate of temperature change with time is

$$\frac{dT_g}{dt} = \frac{6}{\rho_g c_{p,g} D} \left[ \bar{h} (T_\infty - T_g) + \sigma \left( \frac{T_{ea}^4 + T_{sky}^4}{2} - \epsilon_g T_g^4 \right) \right]. \quad <$$

(b) The grape freezes if  $dT_g/dt < 0$  when  $T_g = T_{fp} = 268$  K. With

$$Ra_D = \frac{g \beta (T_\infty - T_g) D^3}{\alpha \nu} = \frac{9.8 \text{ m/s}^2 (3.66 \times 10^{-3} \text{ K}^{-1}) 5 \text{ K} (0.015 \text{ m})^3}{18.9 \times 10^{-6} \times 13.49 \times 10^{-6} \text{ m}^4/\text{s}^2} = 2374$$

using Eq. 9.35 find

$$\bar{Nu}_D = 2 + \frac{0.589 (2374)^{1/4}}{\left[ 1 + (0.469 / Pr)^{9/16} \right]^{4/9}} = 5.17$$

$$\bar{h} = (k/D) \bar{Nu}_D = [(0.0241 \text{ W/m} \cdot \text{K}) / (0.015 \text{ m})] 5.17 = 8.31 \text{ W/m}^2 \cdot \text{K}.$$

Hence, the rate of temperature change is

$$\frac{dT_g}{dt} = \frac{6}{(1000 \text{ kg/m}^3) 4217 \text{ J/kg} \cdot \text{K} (0.015 \text{ m})} \left[ 8.31 \text{ W/m}^2 \cdot \text{K} (5 \text{ K}) + 5.67 \times 10^{-8} \text{ W/m}^2 \cdot \text{K}^4 \left[ \frac{(273^4 + 235^4)}{2} - 268^4 \right] \text{K}^4 \right]$$

Continued ...

**PROBLEM 12.123 (Cont.)**

$$\frac{dT_g}{dt} = 9.49 \times 10^{-5} \text{ K} \cdot \text{m}^2 / \text{J} [41.55 - 48.56] \text{ W} / \text{m}^2 = -6.66 \times 10^{-4} \text{ K} / \text{s} \quad <$$

and since  $dT_g/dt < 0$ , the grape *will freeze*.

(c) For  $V = 1 \text{ m/s}$ ,

$$\text{Re}_D = \frac{VD}{\nu} = \frac{1 \text{ m/s}(0.015 \text{ m})}{13.49 \times 10^{-6} \text{ m}^2 / \text{s}} = 1112.$$

Hence with  $(\mu/\mu_s)^{1/4} = 1$  and from an analysis based upon the content of Chapter 7,

$$\overline{\text{Nu}}_D = 2 + \left( 0.4 \text{Re}_D^{1/2} + 0.06 \text{Re}_D^{2/3} \right) \text{Pr}^{0.4} = 19.3$$

$$\bar{h} = \overline{\text{Nu}}_D \frac{k}{D} = 21.8 \frac{0.0241}{0.015} = 31 \text{ W} / \text{m}^2 \cdot \text{K}.$$

Hence the rate of temperature change with time is

$$\frac{dT_g}{dt} = 9.49 \times 10^{-5} \text{ K} \cdot \text{m}^2 / \text{J} \left[ 31 \text{ W} / \text{m}^2 \cdot \text{K} (5 \text{ K}) - 48.56 \text{ W} / \text{m}^2 \right] = -0.016 \text{ K} / \text{s}$$

and since  $dT_g/dt < 0$  and  $\left| dT_g/dt \right|_c > \left| dT_g/dt \right|_b$ , the grape *will freeze sooner than in part (b)*. <

**COMMENTS:** With  $\text{Gr}_D = \text{Ra}_D/\text{Pr} = 3325$  and  $\text{Gr}_D/\text{Re}_D^2 = 0.0027$ , the assumption of negligible buoyancy for  $V = 1 \text{ m/s}$  is reasonable.

## PROBLEM 12.124

**KNOWN:** Metal disk exposed to environmental conditions and placed in good contact with the earth.

**FIND:** (a) Fraction of direct solar irradiation absorbed, (b) Emissivity of the disk, (c) Average free convection coefficient of the disk upper surface, (d) Steady-state temperature of the disk (confirm the value 340 K).

**SCHEMATIC:**

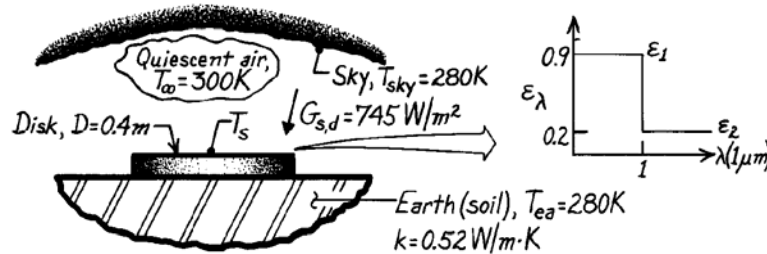

**ASSUMPTIONS:** (1) Steady-state conditions, (2) Disk is diffuse, (3) Disk is isothermal, (4) Negligible contact resistance between disk and earth, (5) Solar irradiance has spectral distribution of  $E_{\lambda,b}(\lambda, 5800 \text{ K})$ .

**PROPERTIES:** Table A-4, Air (1 atm,  $T_f = (T_s + T_\infty)/2 = (340 + 300) \text{ K}/2 = 320 \text{ K}$ ):  $\nu = 17.90 \times 10^{-6} \text{ m}^2/\text{s}$ ,  $k = 0.0278 \text{ W/m}\cdot\text{K}$ ,  $\alpha = 25.5 \times 10^{-6} \text{ m}^2/\text{s}$ ,  $\text{Pr} = 0.704$ .

**ANALYSIS:** (a) The solar absorptivity follows from Eq. 12.53 with  $G_{\lambda,S} \propto E_{\lambda,b}(\lambda, 5800 \text{ K})$ , and  $\alpha_\lambda = \varepsilon_\lambda$ , since the disk surface is diffuse.

$$\alpha_S = \int_0^\infty \alpha_\lambda E_{\lambda,b}(\lambda, 5800 \text{ K}) / E_b(5800 \text{ K})$$

$$\alpha_S = \varepsilon_1 F_{(0 \rightarrow 1 \mu\text{m})} + \varepsilon_2 (1 - F_{(0 \rightarrow 1 \mu\text{m})}).$$

From Table 12.1 with

$$\lambda T = 1 \mu\text{m} \times 5800 \text{ K} = 5800 \mu\text{m}\cdot\text{K} \quad \text{find} \quad F_{(0 \rightarrow \lambda T)} = 0.720$$

giving

$$\alpha_S = 0.9 \times 0.720 + 0.2(1 - 0.720) = 0.704. \quad \leftarrow$$

Note this value is appropriate for diffuse or direct solar irradiation since the surface is diffuse.

(b) The emissivity of the disk depends upon the surface temperature  $T_s$  which we believe to be 340 K. (See part (d)). From Eq. 12.43,

$$\varepsilon = \int_0^\infty \varepsilon_\lambda E_{\lambda,b}(\lambda, T_s) / E_b(T_s)$$

$$\varepsilon = \varepsilon_1 F_{(0 \rightarrow 1 \mu\text{m})} + \varepsilon_2 (1 - F_{(0 \rightarrow 1 \mu\text{m})})$$

Continued ...

**PROBLEM 12.124 (Cont.)**

From Table 12.1 with

$$\lambda T = 1 \mu\text{m} \times 340 \text{ K} = 340 \mu\text{m} \cdot \text{K} \quad \text{find} \quad F_{(0 \rightarrow \lambda T)} = 0.000$$

giving

$$\varepsilon = 0.9 \times 0.000 + 0.2(1 - 0.000) = 0.20. \quad <$$

(c) The disk is a hot surface facing upwards for which the free convection correlation of Eq. 9.30 is appropriate. Evaluating properties at  $T_f = (T_s + T_\infty)/2 = 320 \text{ K}$ ,

$$\text{Ra}_L = g\beta\Delta TL^3 / \nu\alpha \quad \text{where} \quad L = A_s / P = D/4$$

$$\text{Ra}_L = 9.8 \text{ m/s}^2 (1/320 \text{ K})(340 - 300) \text{ K} (0.4 \text{ m}/4)^3 / 17.90 \times 10^{-6} \text{ m}^2/\text{s} \times 25.5 \times 10^{-6} \text{ m}^2/\text{s} = 2.684 \times 10^6$$

$$\overline{\text{Nu}}_L = \bar{h}L/k = 0.54 \text{Ra}_L^{1/4} \quad 10^4 \leq \text{Ra}_L \leq 10^7$$

$$\bar{h} = 0.0278 \text{ W/m} \cdot \text{K} / (0.4 \text{ m}/4) \times 0.54 (3.042 \times 10^6)^{1/4} = 6.07 \text{ W/m}^2 \cdot \text{K}. \quad <$$

(d) To determine the steady-state temperature, perform an energy balance on the disk.

$$\dot{E}_{\text{in}} - \dot{E}_{\text{out}} = \dot{E}_{\text{st}}$$

$$(\alpha_S G_{S,d} + \alpha G_{\text{atm}} - \varepsilon E_b - q''_{\text{conv}}) A_s - q_{\text{cond}} = 0.$$

Since  $G_{\text{atm}}$  is predominately long wavelength radiation, it follows that  $\alpha = \varepsilon$ . The conduction heat rate between the disk and the earth is

$$q_{\text{cond}} = kS(T_s - T_{\text{ea}}) = k(2D)(T_s - T_{\text{ea}})$$

where  $S$ , the conduction shape factor, is that of an isothermal disk on a semi-infinite medium, Table 4.1. Substituting numerical values, with  $A_s = \pi D^2/4$ ,

$$\left[ 0.704 \times 745 \text{ W/m}^2 + 0.20\sigma(280 \text{ K})^4 - 0.20\sigma T_s^4 - 6.07 \text{ W/m}^2 \cdot \text{K} (T_s - 300 \text{ K}) \right] \pi (0.4 \text{ m})^2 / 4 - 0.52 \text{ W/m} \cdot \text{K} (2 \times 0.4 \text{ m})(T_s - 280 \text{ K}) = 0$$

$$65.908 \text{ W} + 8.759 \text{ W} - 1.425 \times 10^{-9} T_s^4 - 0.763(T_s - 300) - 0.416(T_s - 280) = 0.$$

By trial-and-error, find

$$T_s \approx 340 \text{ K}. \quad <$$

so indeed the assumed value of 340 K was proper.

**COMMENTS:** Note why it is not necessary for this situation to distinguish between direct and diffuse irradiation. Why does  $\alpha_{\text{sky}} = \varepsilon$ ?

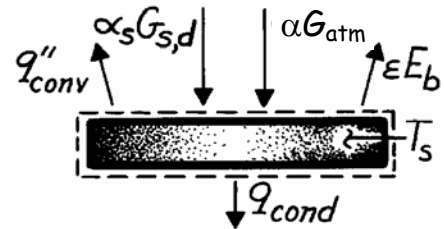

## PROBLEM 12.125

**KNOWN:** Shed roof of weathered galvanized sheet metal exposed to solar insolation on a cool, clear spring day with ambient air at  $-10^\circ\text{C}$  and convection coefficient estimated by the empirical correlation  $\bar{h} = 1.0 \Delta T^{1/3}$  ( $\text{W}/\text{m}^2 \cdot \text{K}$  with temperature units of kelvins).

**FIND:** Temperature of the roof,  $T_s$ , (a) assuming the backside is well insulated, and (b) assuming the backside is exposed to ambient air with the same convection coefficient relation and experiences radiation exchange with the ground, also at the ambient air temperature. Comment on whether the roof will be a comfortable place for the neighborhood cat to snooze for these conditions.

**SCHEMATIC:**

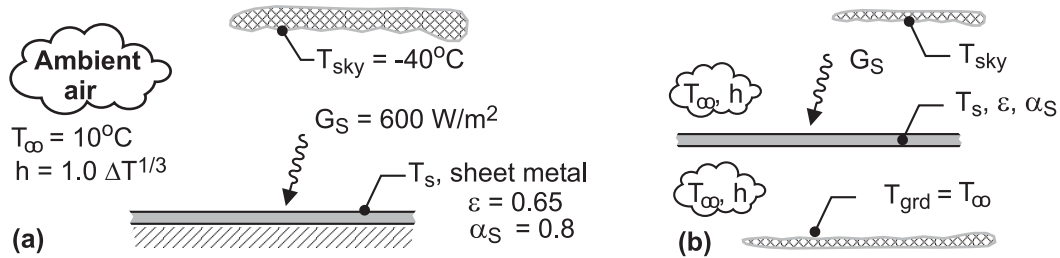

**ASSUMPTIONS:** (1) Steady-state conditions, (2) The roof surface is diffuse, spectrally selective, (3) Sheet metal is thin with negligible thermal resistance, and (3) Roof is a small object compared to the large isothermal surroundings represented by the sky and the ground.

**ANALYSIS:** (a) For the backside-insulated condition, the energy balance, represented schematically below, is

$$\begin{aligned} \dot{E}''_{\text{in}} - \dot{E}''_{\text{out}} &= 0 \\ \alpha_{\text{sky}} E_b(T_{\text{sky}}) + \alpha_S G_S - q''_{\text{cv}} - \varepsilon E_b(T_s) &= 0 \\ \alpha_{\text{sky}} \sigma T_{\text{sky}}^4 + \alpha_S G_S - 1.0(T_s - T_\infty)^{4/3} - \varepsilon \sigma T_s^4 &= 0 \end{aligned}$$

With  $\alpha_{\text{sky}} = \varepsilon$  (see Comment 2) and  $\sigma = 5.67 \times 10^{-8} \text{ W}/\text{m}^2 \cdot \text{K}^4$ , find  $T_s$ .

$$0.65 \sigma (233 \text{ K})^4 \text{ W}/\text{m}^2 + 0.8 \times 600 \text{ W}/\text{m}^2 - 1.0(T_s - 283 \text{ K})^{4/3} \text{ W}/\text{m}^2 - 0.65 \sigma T_s^4 = 0$$

$$T_s = 328.2 \text{ K} = 55.2^\circ\text{C} \quad <$$

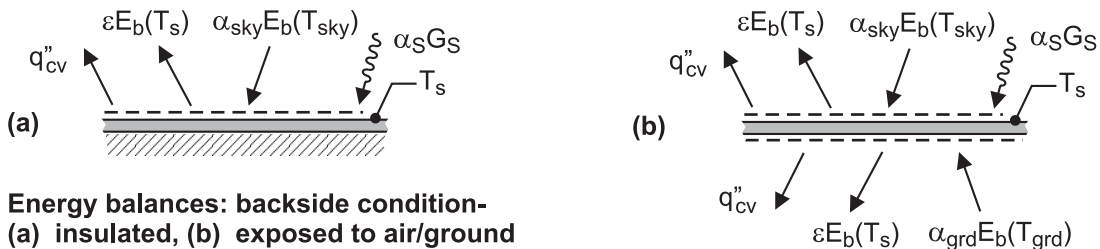

Continued ...

### PROBLEM 12.125 (Cont.)

(b) With the backside exposed to convection with the ambient air and radiation exchange with the ground, the energy balance, represented schematically above, is

$$\alpha_{\text{sky}} E_b(T_{\text{sky}}) + \alpha_{\text{grd}} E_b(T_{\text{grd}}) + \alpha_S G_S - 2q''_{\text{cv}} - 2\varepsilon E_b(T_s) = 0$$

Substituting numerical values, recognizing that  $T_{\text{grd}} = T_{\infty}$ , and  $\alpha_{\text{grd}} = \varepsilon$  (see Comment 2), find  $T_s$ .

$$0.65 \sigma (233 \text{ K})^4 \text{ W/m}^2 + 0.65 \sigma (283 \text{ K})^4 \text{ W/m}^2 + 0.8 \times 600 \text{ W/m}^2 \\ - 2 \times 1.0 (T_s - 283 \text{ K})^{4/3} \text{ W/m}^2 - 2 \times 0.65 \sigma T_s^4 = 0$$

$$T_s = 308.9 \text{ K} = 35.9^\circ\text{C}$$

<

**COMMENTS:** (1) For the insulated-backside condition, the cat would find the roof too hot remembering that  $43^\circ\text{C}$  represents a safe-to-touch temperature. For the exposed-backside condition, the cat would find the roof comfortable, certainly compared to an area not exposed to the solar insolation (that is, exposed only to the ambient air through convection).

(2) For this spectrally selective surface, the absorptivity for the sky irradiation is equal to the emissivity,  $\alpha_{\text{sky}} = \varepsilon$ , since the sky irradiation and surface emission have the same approximate spectral regions. The same reasoning applies for the absorptivity of the ground irradiation,  $\alpha_{\text{grd}} = \varepsilon$ .

## PROBLEM 12.126

**KNOWN:** Amplifier operating and environmental conditions.

**FIND:** (a) Power generation when  $T_s = 58^\circ\text{C}$  with diffuse coating  $\varepsilon = 0.5$ , (b) Diffuse coating from among three (A, B, C) which will give greatest reduction in  $T_s$ , and (c) Surface temperature for the conditions with coating chosen in part (b).

**SCHEMATIC:**

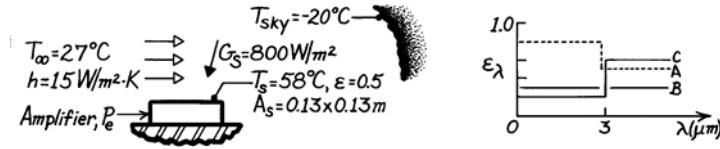

**ASSUMPTIONS:** (1) Environmental conditions remain the same with all surface coatings, (2) Coatings A, B, C are opaque, diffuse.

**ANALYSIS:** (a) Performing an energy balance on the amplifier's exposed surface,

$\dot{E}_{in} - \dot{E}_{out} = 0$ , we find

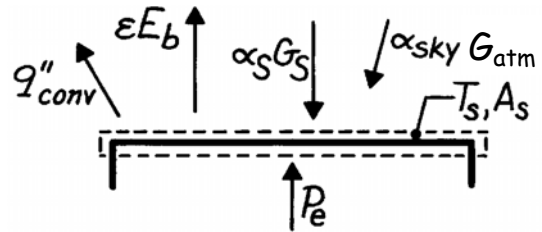

$$P_e + A_s [\alpha_S G_S + \alpha_{atm} G_{atm} - \varepsilon E_b - q''_{conv}] = 0$$

$$P_e = A_s \left[ \varepsilon \sigma T_s^4 + h(T_s - T_\infty) - \alpha_S G_S - \alpha_{atm} \sigma T_{sky}^4 \right]$$

$$P_e = 0.13 \times 0.13 \text{ m}^2 \left[ 0.5 \times \sigma (331)^4 + 15(331 - 300) - 0.5 \times 800 - 0.5 \times \sigma (253)^4 \right] \text{ W/m}^2$$

$$P_e = 0.0169 \text{ m}^2 [0.5 \times 680.6 + 465 - 0.5 \times 800 - 0.5 \times 232.3] \text{ W/m}^2 = 4.887 \text{ W.} \quad <$$

(b) From above, recognize that we seek a coating with low  $\alpha_S$  and high  $\varepsilon$  to decrease  $T_s$ . Further, recognize that  $\alpha_S$  is determined by values of  $\alpha_\lambda = \varepsilon_\lambda$  for  $\lambda < 3 \mu\text{m}$  and  $\varepsilon$  by values of  $\varepsilon_\lambda$  for  $\lambda > 3 \mu\text{m}$ . Find approximate values as

Coating	A	B	C
$\varepsilon$	0.5	0.3	0.6
$\alpha_S$	0.8	0.3	0.2
$\alpha_S/\varepsilon$	1.6	1	0.333

Note also that  $\alpha_{atm} \approx \varepsilon$ . We conclude that coating C is likely to give the lowest  $T_s$  since its  $\alpha_S/\varepsilon$  is substantially lower than for B and C. While  $\alpha_{atm}$  for C is twice that of B, because  $G_{atm}$  is nearly 25% that of  $G_S$ , we expect coating C to give the lowest  $T_s$ .

(c) With the values of  $\alpha_S$ ,  $\alpha_{atm}$  and  $\varepsilon$  for coating C from part (b), rewrite the energy balance as

$$P_e / A_s + \alpha_S G_S + \alpha_{atm} \sigma T_{sky}^4 - \varepsilon \sigma T_s^4 - h(T_s - T_\infty) = 0$$

$$4.887 \text{ W}/(0.13 \text{ m})^2 + 0.2 \times 800 \text{ W/m}^2 + 0.6 \times 232.3 \text{ W/m}^2 - 0.6 \times \sigma T_s^4 - 15(T_s - 300) = 0$$

Using trial-and-error, find  $T_s = 316.5 \text{ K} = 43.5^\circ\text{C}$ . <

**COMMENTS:** (1) Using coatings A and B, find  $T_s = 71$  and  $54^\circ\text{C}$ , respectively. (2) For more precise values of  $\alpha_S$ ,  $\alpha_{sky}$  and  $\varepsilon$ , use  $T_s = 43.5^\circ\text{C}$ . For example, at  $\lambda T_s = 3 \times (43.5 + 273) = 950 \mu\text{m}\cdot\text{K}$ ,  $F_{0-\lambda T} = 0.000$  while at  $\lambda T_{solar} = 3 \times 5800 = 17,400 \mu\text{m}\cdot\text{K}$ ,  $F_{0-\lambda T} \approx 0.98$ ; we conclude little effect will be seen.



## PROBLEM 12.127

**KNOWN:** Opaque, spectrally-selective horizontal plate with electrical heater on backside is exposed to convection, solar irradiation and sky irradiation.

**FIND:** Electrical power required to maintain plate at 60°C.

**SCHEMATIC:**

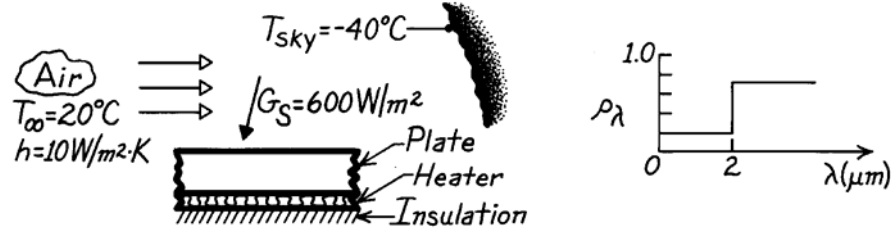

**ASSUMPTIONS:** (1) Plate is opaque, diffuse and uniform, (2) No heat lost out the backside of heater.

**ANALYSIS:** From an energy balance on the plate-heater system, per unit area basis,

$$\begin{aligned} \dot{E}_{in}'' - \dot{E}_{out}'' &= 0 \\ q_{elec}'' + \alpha_S G_S + \alpha G_{atm} \\ -\varepsilon E_b(T_s) - q_{conv}'' &= 0 \end{aligned}$$

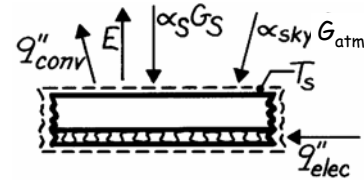

where  $G_{atm} = \sigma T_{sky}^4$ ,  $E_b = \sigma T_s^4$ , and  $q_{conv}'' = h(T_s - T_\infty)$ . The solar absorptivity is

$$\alpha_S = \int_0^\infty \alpha_\lambda G_{\lambda,S} d\lambda / \int_0^\infty G_{\lambda,S} d\lambda = \int_0^\infty \alpha_\lambda E_{\lambda,b}(\lambda, 5800 \text{ K}) d\lambda / \int_0^\infty E_{\lambda,b}(\lambda, 5800 \text{ K}) d\lambda$$

where  $G_{\lambda,S} \sim E_{\lambda,b}(\lambda, 5800 \text{ K})$ . Noting that  $\alpha_\lambda = 1 - \rho_\lambda$ ,

$$\alpha_S = (1 - 0.2)F_{(0-2\mu\text{m})} + (1 - 0.7)(1 - F_{(0-2\mu\text{m})})$$

where at  $\lambda T = 2 \mu\text{m} \times 5800 \text{ K} = 11,600 \mu\text{m}\cdot\text{K}$ , find from Table 12.1,  $F_{(0-\lambda T)} = 0.941$ ,

$$\alpha_S = 0.80 \times 0.941 + 0.3(1 - 0.941) = 0.771.$$

The total, hemispherical emissivity is

$$\varepsilon = (1 - 0.2)F_{(0-2\mu\text{m})} + (1 - 0.7)(1 - F_{(0-2\mu\text{m})}).$$

At  $\lambda T = 2 \mu\text{m} \times 333 \text{ K} = 666 \text{ K}$ , find  $F_{(0-\lambda T)} \approx 0.000$ ; hence  $\varepsilon = 0.30$ . The total, hemispherical absorptivity for sky irradiation is  $\alpha = \varepsilon = 0.30$  since the surface is gray for this emission and irradiation process. Substituting numerical values,

$$q_{elec}'' = \varepsilon \sigma T_s^4 + h(T_s - T_\infty) - \alpha_S G_S - \alpha \sigma T_{sky}^4$$

$$q_{elec}'' = 0.30 \times \sigma (333 \text{ K})^4 + 10 \text{ W/m}^2 \cdot \text{K} (60 - 20)^\circ\text{C} - 0.771 \times 600 \text{ W/m}^2 - 0.30 \times \sigma (233 \text{ K})^4$$

$$q_{elec}'' = 209.2 \text{ W/m}^2 + 400.0 \text{ W/m}^2 - 462.6 \text{ W/m}^2 - 50.1 \text{ W/m}^2 = 96.5 \text{ W/m}^2. \quad <$$

**COMMENTS:** (1) Note carefully why  $\alpha_{sky} = \varepsilon$  for the sky irradiation.

## PROBLEM 12.128

**KNOWN:** Chord length and spectral emissivity of wing. Ambient air temperature, sky temperature and solar irradiation for ground and in-flight conditions. Flight speed.

**FIND:** Temperature of top surface of wing for (a) ground and (b) in-flight conditions.

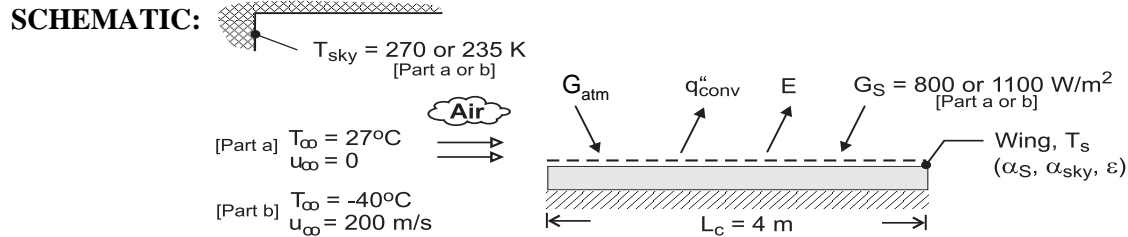

**ASSUMPTIONS:** (1) Steady-state, (2) Negligible heat transfer from back of wing surface, (3) Diffuse surface behavior, (4) Negligible solar radiation for  $\lambda > 3 \mu\text{m}$  ( $\alpha_S = \alpha_{\lambda \leq 3 \mu\text{m}} = \epsilon_{\lambda \leq 3 \mu\text{m}} = 0.6$ ), (5) Negligible sky radiation and surface emission for  $\lambda \leq 3 \mu\text{m}$  ( $\alpha_{\text{sky}} = \alpha_{\lambda > 3 \mu\text{m}} = \epsilon_{\lambda > 3 \mu\text{m}} = 0.3 = \epsilon$ ), (6) Quiescent air for ground condition, (7) Air foil may be approximated as a flat plate, (8) Negligible viscous heating in boundary layer for in-flight condition, (9) The wing span  $W$  is much larger than the chord length  $L_c$ , (10) In-flight transition Reynolds number is  $5 \times 10^5$ .

**PROPERTIES:** Part (a). Table A-4, air ( $T_f \approx 325 \text{ K}$ ):  $\nu = 1.84 \times 10^{-5} \text{ m}^2/\text{s}$ ,  $\alpha = 2.62 \times 10^{-5} \text{ m}^2/\text{s}$ ,  $k = 0.0282 \text{ W/m}\cdot\text{K}$ ,  $\beta = 0.00307$ . Part (b). Given:  $\rho = 0.470 \text{ kg/m}^3$ ,  $\mu = 1.50 \times 10^{-5} \text{ N}\cdot\text{s/m}^2$ ,  $k = 0.021 \text{ W/m}\cdot\text{K}$ ,  $\text{Pr} = 0.72$ .

**ANALYSIS:** For both ground and in-flight conditions, a surface energy balance yields

$$\alpha_{\text{sky}} G_{\text{sky}} + \alpha_S G_S = \epsilon \sigma T_s^4 + \bar{h} (T_s - T_\infty) \quad (1)$$

where  $\alpha_{\text{sky}} = \epsilon = 0.3$ , and  $\alpha_S = 0.6$ .

(a) For the ground condition,  $\bar{h}$  may be evaluated from Eq. 9.30 or 9.31, where  $L = A_s/P = L_c \times W/2$  ( $L_c + W$ )  $\approx L_c/2 = 2 \text{ m}$  and  $\text{Ra}_L = g\beta(T_s - T_\infty)L^3/\nu\alpha$ . Using the *IHT* software to solve Eq. (1) and accounting for the effect of temperature-dependent properties, the surface temperature is

$$T_s = 350.6 \text{ K} = 77.6^\circ\text{C} \quad \leftarrow$$

where  $\text{Ra}_L = 2.52 \times 10^{10}$  and  $\bar{h} = 6.2 \text{ W/m}^2\cdot\text{K}$ . Heat transfer from the surface by emission and convection is  $257.0$  and  $313.6 \text{ W/m}^2$ , respectively.

(b) For the in-flight condition,  $\text{Re}_L = \rho u_\infty L_c / \mu = 0.470 \text{ kg/m}^3 \times 200 \text{ m/s} \times 4 \text{ m} / 1.50 \times 10^{-5} \text{ N}\cdot\text{s/m}^2 = 2.51 \times 10^7$ . For mixed, laminar/turbulent boundary layer conditions (Chapter 7) and a transition Reynolds number of  $\text{Re}_{x,c} = 5 \times 10^5$ .

$$\overline{\text{Nu}}_L = \left( 0.037 \text{Re}_L^{4/5} - 871 \right) \text{Pr}^{1/3} = 26,800$$

$$\bar{h} = \frac{k}{L} \overline{\text{Nu}}_L = \frac{0.021 \text{ W/m}\cdot\text{K} \times 26,800}{4 \text{ m}} = 141 \text{ W/m}^2\cdot\text{K}$$

Substituting into Eq. (1), a trial-and-error solution yields

$$T_s = 237.7 \text{ K} = -35.3^\circ\text{C} \quad \leftarrow$$

Heat transfer from the surface by emission and convection is now  $54.3$  and  $657.6 \text{ W/m}^2$ , respectively.

**COMMENTS:** The temperature of the wing is strongly influenced by the convection heat transfer coefficient, and the large coefficient associated with flight yields a surface temperature that is within  $5^\circ\text{C}$  of the air temperature.

## PROBLEM 12.129

**KNOWN:** Spectrally selective and gray surfaces in earth orbit are exposed to solar irradiation,  $G_S$ , in a direction  $30^\circ$  from the normal to the surfaces.

**FIND:** Equilibrium temperature of each plate.

**SCHEMATIC:**

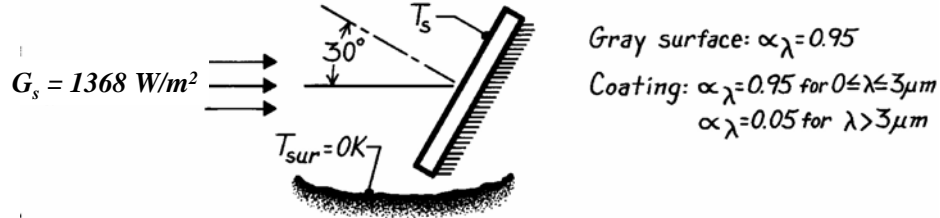

**ASSUMPTIONS:** (1) Plates are at uniform temperature, (2) Surroundings are at 0K, (3) Steady-state conditions, (4) Solar irradiation has spectral distribution of  $E_{\lambda,b}(\lambda, 5800\text{K})$ , (5) Back side of plate is insulated.

**ANALYSIS:** Noting that the solar irradiation is directional (at  $30^\circ$  from the normal), the radiation balance has the form

$$\alpha_S G_S \cos \theta - \varepsilon E_b(T_S) = 0. \quad (1)$$

Using  $E_b(T_S) = \sigma T_S^4$  and solving for  $T_S$ , find

$$T_S = \left[ (\alpha_S / \varepsilon) (G_S \cos \theta / \sigma) \right]^{1/4}. \quad (2)$$

For the *gray surface*,  $\alpha_S = \varepsilon = \alpha_\lambda$  and the temperature is independent of the magnitude of the absorptivity.

$$T_S = \left( \frac{0.95}{0.95} \times \frac{1368 \text{ W/m}^2 \times \cos 30^\circ}{5.67 \times 10^{-8} \text{ W/m}^2 \cdot \text{K}^4} \right)^{1/4} = 380 \text{ K.} \quad <$$

For the *selective surface*,  $\alpha_S = 0.95$  since nearly all the solar spectral power is in the region  $\lambda < 3\mu\text{m}$ . The value of  $\varepsilon$  depends upon the surface temperature  $T_S$  and would be determined by the relation.

$$\varepsilon = 0.95 F_{(0 \rightarrow \lambda T_S)} + 0.05 \left[ 1 - F_{(0 \rightarrow \lambda T_S)} \right] \quad (3)$$

where  $\lambda = 3\mu\text{m}$  and  $T_S$  is as yet unknown. To find  $T_S$ , a trial-and-error procedure as follows will be used: (1) assume a value of  $T_S$ , (2) using Eq. (3), calculate  $\varepsilon$  with the aid of Table 12.1 evaluating  $F_{(0 \rightarrow \lambda T)}$  at  $\lambda T_S = 3\mu\text{m} \cdot T_S$ , (3) with this value of  $\varepsilon$ , calculate  $T_S$  from Eq. (2) and compare with assumed value of  $T_S$ . The results of the iterations are:

$T_S(\text{K})$ , assumed value	633	700	666	650	655
$\varepsilon$ , from Eq. (3)	0.098	0.125	0.110	0.104	0.106
$T_S(\text{K})$ , from Eq. (2)	656	629	650	659	656

Hence, for the coating,  $T_S \approx 656\text{K}$ . <

**COMMENTS:** Note the role of the ratio  $\alpha_s/\varepsilon$  in determining the equilibrium temperature of an isolated plate exposed to solar irradiation in space. This is an important property of the surface in spacecraft thermal design and analysis.

## PROBLEM 12.130

**KNOWN:** Spectral distribution of coating on satellite surface. Irradiation from earth and sun.

**FIND:** (a) Steady-state temperature of satellite on dark side of earth, (b) Steady-state temperature on bright side.

**SCHEMATIC:**

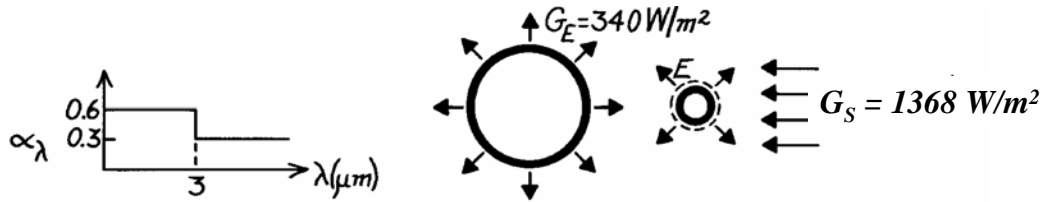

**ASSUMPTIONS:** (1) Steady-state conditions, (2) Opaque, diffuse-gray surface behavior, (3) Spectral distributions of earth and solar emission may be approximated as those of blackbodies at 280K and 5800K, respectively, (4) Satellite temperature is less than 500K.

**ANALYSIS:** Performing an energy balance on the satellite,

$$\dot{E}_{\text{in}} - \dot{E}_{\text{out}} = 0$$

$$\alpha_E G_E \left( \pi D^2 / 4 \right) + \alpha_S G_S \left( \pi D^2 / 4 \right) - \varepsilon \sigma T_s^4 \left( \pi D^2 \right) = 0$$

$$T_s = \left( \frac{\alpha_E G_E + \alpha_S G_S}{4 \varepsilon \sigma} \right)^{1/4}.$$

From Table 12.1, with 98% of radiation below  $3 \mu\text{m}$  for  $\lambda T = 17,400 \mu\text{m} \cdot \text{K}$ ,

$$\alpha_S \cong 0.6.$$

With 98% of radiation above  $3 \mu\text{m}$  for  $\lambda T = 3 \mu\text{m} \times 500\text{K} = 1500 \mu\text{m} \cdot \text{K}$ ,

$$\varepsilon \approx 0.3 \quad \alpha_E \approx 0.3.$$

(a) On *dark* side,

$$T_s = \left( \frac{\alpha_E G_E}{4 \varepsilon \sigma} \right)^{1/4} = \left( \frac{0.3 \times 340 \text{ W/m}^2}{4 \times 0.3 \times 5.67 \times 10^{-8} \text{ W/m}^2 \cdot \text{K}^4} \right)^{1/4}$$

$$T_s = 197 \text{ K.} \quad <$$

(b) On *bright* side,

$$T_s = \left( \frac{\alpha_E G_E + \alpha_S G_S}{4 \varepsilon \sigma} \right)^{1/4} = \left( \frac{0.3 \times 340 \text{ W/m}^2 + 0.6 \times 1368 \text{ W/m}^2}{4 \times 0.3 \times 5.67 \times 10^{-8} \text{ W/m}^2 \cdot \text{K}^4} \right)^{1/4}$$

$$T_s = 341 \text{ K.} \quad <$$

### PROBLEM 12.131

**KNOWN:** Radiative properties and operating conditions of a space radiator.

**FIND:** Equilibrium temperature of the radiator.

**SCHEMATIC:**

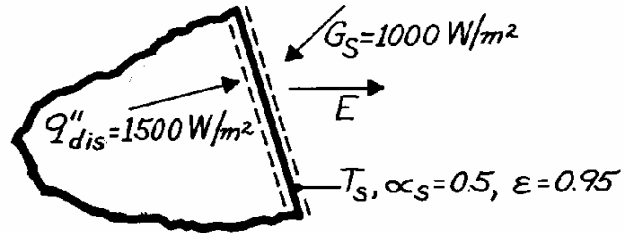

**ASSUMPTIONS:** (1) Steady-state conditions, (2) Negligible irradiation due to earth emission.

**ANALYSIS:** From a surface energy balance,  $\dot{E}''_{in} - \dot{E}''_{out} = 0$ .

$$q''_{dis} + \alpha_S G_S - E = 0.$$

Hence

$$T_s = \left( \frac{q''_{dis} + \alpha_S G_S}{\epsilon \sigma} \right)^{1/4}$$

$$T_s = \left( \frac{1500 \text{ W/m}^2 + 0.5 \times 1000 \text{ W/m}^2}{0.95 \times 5.67 \times 10^{-8} \text{ W/m}^2 \cdot \text{K}^4} \right)^{1/4}$$

or

$$T_s = 439 \text{ K.} \quad <$$

**COMMENTS:** *Passive* thermal control of spacecraft is practiced by using surface coatings with desirable values of  $\alpha_S$  and  $\epsilon$ .

## PROBLEM 12.132

**KNOWN:** Spherical satellite exposed to solar irradiation of  $1368 \text{ W/m}^2$ ; surface is to be coated with a checker pattern of evaporated aluminum film, (fraction,  $F$ ) and white zinc-oxide paint ( $1 - F$ ).

**FIND:** The fraction  $F$  for the checker pattern required to maintain the satellite at  $300 \text{ K}$ .

**SCHEMATIC:**

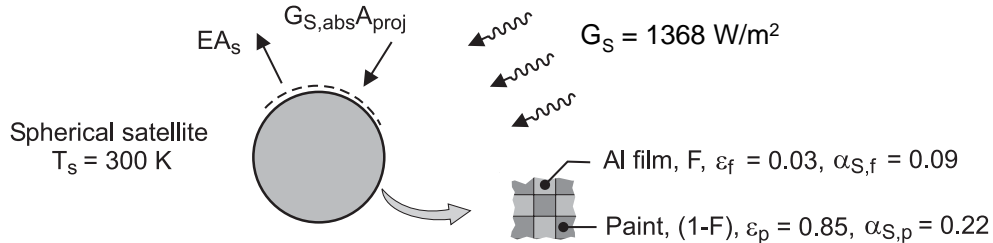

**ASSUMPTIONS:** (1) Steady-state conditions, (2) Satellite is isothermal, and (3) No internal power dissipation.

**ANALYSIS:** Perform an energy balance on the satellite, as illustrated in the schematic, identifying absorbed solar irradiation on the projected area,  $A_p$ , and emission from the spherical area  $A_s$ .

$$\dot{E}_{\text{in}} + \dot{E}_{\text{out}} = 0$$

$$\left( F \cdot \alpha_{S,f} + (1-F) \cdot \alpha_{S,p} \right) G_S A_p - \left( F \cdot \varepsilon_f + (1-F) \cdot \varepsilon_p \right) E_b (T_s) A_s = 0$$

where  $A_p = \pi D^2 / 4$ ,  $A_s = \pi D^2$ ,  $E_b = \sigma T^4$  and  $\sigma = 5.67 \times 10^{-8} \text{ W/m}^2 \cdot \text{K}^4$ . Substituting numerical values, find  $F$ .

$$\frac{\left[ F \times 0.09 + (1-F) \times 0.22 \right] \times 1368 \text{ W/m}^2}{4} - \left[ F \times 0.03 + (1-F) \times 0.85 \times \sigma \times (300\text{K})^4 \right] = 0$$

$$F = 0.94$$

<

**COMMENTS:** (1) If the thermal control engineer desired to maintain the spacecraft at  $325 \text{ K}$ , would the fraction  $F$  (aluminum film) be increased or decreased? Verify your opinion with a calculation.

(2) If the internal power dissipation per unit surface area is  $150 \text{ W/m}^2$ , what fraction  $F$  will maintain the satellite at  $300 \text{ K}$ ?

### PROBLEM 12.133

**KNOWN:** Inner and outer radii, spectral reflectivity, and thickness of an annular fin. Base temperature and solar irradiation.

**FIND:** (a) Rate of heat dissipation if  $\eta_f = 1$ , (b) Differential equation governing radial temperature distribution in fin if  $\eta_f < 1$ .

**SCHEMATIC:**

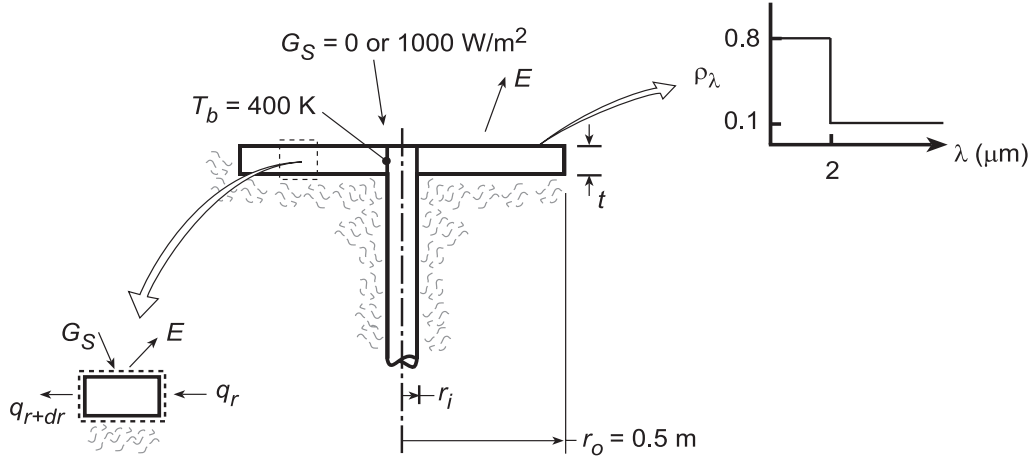

**ASSUMPTIONS:** (1) Steady-state, (2) One-dimensional radial conduction, (3) Adiabatic tip and bottom surface, (4) Opaque, diffuse surface ( $\alpha_\lambda = 1 - \rho_\lambda$ ,  $\varepsilon_\lambda = \alpha_\lambda$ ).

**ANALYSIS:** (a) If  $\eta_f = 1$ ,  $T(r) = T_b = 400$  K across the entire fin and

$$q_f = [\varepsilon E_b(T_b) - \alpha_S G_S] \pi r_o^2$$

With  $\lambda T = 2 \mu\text{m} \times 5800 \text{ K} = 11,600 \mu\text{m}\cdot\text{K}$ ,  $F_{(0 \rightarrow 2\mu\text{m})} = 0.941$ . Hence  $\alpha_S = \alpha_1 F_{(0 \rightarrow 2\mu\text{m})} +$

$\alpha_2 [1 - F_{(0 \rightarrow 2\mu\text{m})}] = 0.2 \times 0.941 + 0.9 \times 0.059 = 0.241$ . With  $\lambda T = 2 \mu\text{m} \times 400 \text{ K} = 800 \mu\text{m}\cdot\text{K}$ ,

$F_{(0 \rightarrow 2\mu\text{m})} = 0$  and  $\varepsilon = 0.9$ . Hence, for  $G_S = 0$ ,

$$q_f = 0.9 \times 5.67 \times 10^{-8} \text{ W/m}^2 \cdot \text{K}^4 (400 \text{ K})^4 \pi (0.5 \text{ m})^2 = 1026 \text{ W} \quad <$$

and for  $G_S = 1000 \text{ W/m}^2$ ,

$$q_f = 1026 \text{ W} - 0.241 (1000 \text{ W/m}^2) \pi (0.5 \text{ m})^2 = (1026 - 189) \text{ W} = 837 \text{ W} \quad <$$

(b) Performing an energy balance on a differential element extending from  $r$  to  $r+dr$ , we obtain

$$q_r + \alpha_S G_S (2\pi r dr) - q_{r+dr} - E (2\pi r dr) = 0$$

where

$$q_r = -k (dT/dr) 2\pi r t \quad \text{and} \quad q_{r+dr} = q_r + (dq_r/dr) dr.$$

Hence,

$$\alpha_S G_S (2\pi r dr) - d[-k (dT/dr) 2\pi r t] dr - E (2\pi r dr) = 0$$

$$2\pi r t k \frac{d^2 T}{dr^2} + 2\pi t k \frac{dT}{dr} + \alpha_S G_S 2\pi r - E 2\pi r = 0$$

$$k t \left( \frac{d^2 T}{dr^2} + \frac{1}{r} \frac{dT}{dr} \right) + \alpha_S G_S - \varepsilon \sigma T^4 = 0 \quad <$$

**COMMENTS:** The radiator should be constructed of a light weight, high thermal conductivity material (aluminum).

## PROBLEM 12.134

**KNOWN:** Rectangular plate, with prescribed geometry and thermal properties, for use as a radiator in a spacecraft application. Radiator exposed to solar radiation on upper surface, and to deep space on both surfaces.

**FIND:** Using a computer-based, finite-difference method with a space increment of 0.1 m, find the tip temperature,  $T_L$ , and rate of heat rejection,  $q_f$ , when the base temperature is maintained at  $80^\circ\text{C}$  for the cases: (a) when exposed to the sun, (b) on the dark side of the earth, not exposed to the sun; and (c) when the thermal conductivity is extremely large. Compare the case (c) results with those obtained from a hand calculation assuming the radiator is at a uniform temperature.

**SCHEMATIC:**

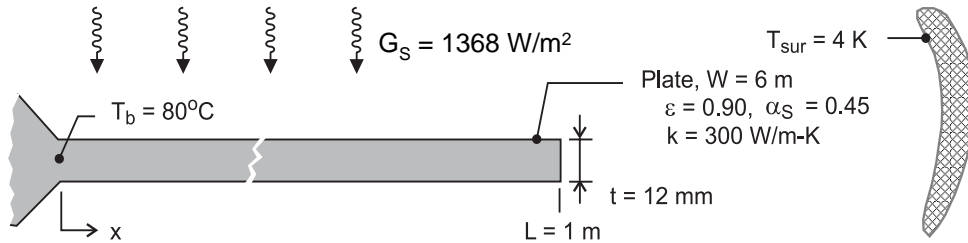

**ASSUMPTIONS:** (1) Steady-state conditions, (b) Plate-radiator behaves as an extended surface with one-dimensional conduction, and (c) Radiating tip condition.

**ANALYSIS:** The finite-difference network with 10 nodes and a space increment  $\Delta x = 0.1$  m is shown in the schematic below. The finite-difference equations (FDEs) are derived for an interior node (nodes 01 - 09) and the tip node (10). The energy balances are represented also in the schematic below where  $q_a$  and  $q_b$  represent conduction heat rates,  $q_S$  represents the absorbed solar radiation, and  $q_{rad}$  represents the radiation exchange with outer space.

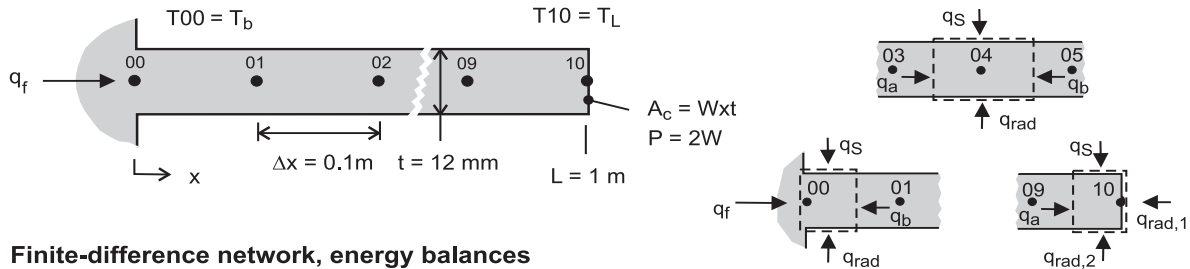

**Finite-difference network, energy balances**

*Interior node 04*

$$\begin{aligned} \dot{E}_{in} - \dot{E}_{out} &= 0 \\ q_a + q_b + q_S + q_{rad} &= 0 \\ kA_c (T_{03} - T_{04}) / \Delta x + kA_c (T_{05} - T_{04}) / \Delta x \\ &+ \alpha_S G_S (P/2)\Delta x + \varepsilon P \Delta x \sigma (T_{sur}^4 - T_{04}^4) = 0 \end{aligned}$$

where  $P = 2W$  and  $A_c = W \cdot t$ .

*Tip node 10*

$$\begin{aligned} q_a + q_S + q_{rad,1} + q_{rad,2} &= 0 \\ kA_c (T_{09} - T_{10}) / \Delta x + \alpha_S G_S (P/2) (\Delta x / 2) \\ &+ \varepsilon A_c \sigma (T_{sur}^4 - T_{10}^4) + \varepsilon P (\Delta x / 2) \sigma (T_{sur}^4 - T_{04}^4) = 0 \end{aligned}$$

Continued ...



### PROBLEM 12.134 (Cont.)

Heat rejection,  $q_f$ . From an energy balance on the base node 00,

$$q_f + q_{01} + q_S + q_{\text{rad}} = 0$$

$$q_f + kA_c (T_{01} - T_{00}) / \Delta x + \alpha_S G_S (P/2) (\Delta x/2) + \varepsilon P (\Delta x/2) \sigma (T_{\text{sur}}^4 - T_{00}^4) = 0$$

The foregoing nodal equations and the heat rate expression were entered into the *IHT* workspace to obtain solutions for the three cases. See Comment 2 for the *IHT* code, and Comment 1 for code validation remarks.

Case	$k(\text{W/m}\cdot\text{K})$	$G_S(\text{W/m}^2)$	$T_L(^{\circ}\text{C})$	$q_f(\text{W})$	
a	300	1368	30.9	2746	<
b	300	0	-7.6	4720	<
c	$1 \times 10^{10}$	0	80.0	9565	<

Case (c) using the *IHT* code with  $k = 1 \times 10^{10}$  W/m·K corresponds to the condition of the plate at the uniform temperature of the base; that is  $T(x) = T_b$ . For this condition, the heat rejection from the upper and lower surfaces and the tip area can be calculated as

$$q_{f,u} = \varepsilon \sigma (T_b^4 - T_{\text{sur}}^4) [P \cdot L + A_c]$$

$$q_{f,u} = 0.9 \sigma [(80 + 273)^4 - 4^4] \text{W/m}^2 [12 + 6 \times 0.012] \text{m}^2$$

$$= 9674 \text{ W}$$

Note that the heat rejection rate for the uniform plate is in excellent agreement with the result of the FDE analysis when the thermal conductivity is made extremely large. We have confidence that the code is properly handling the conduction and radiation processes; but, we have not exercised the portion of the code dealing with the absorbed irradiation. What analytical solution/model could you use to validate this portion of the code?

**COMMENTS:** (1) The *IHT* code with the 10-nodal FDEs for the temperature distribution and the heat rejection rate is as follows.

#### **//Properties and dimensions**

```

W = 6 //m
t = 12/1000 //m
k = 300 //thermal conductivity (W/m-K)
eps = 0.90 //emissivity
absS = 0.45 //solar absorptivity
//Conditions
Tsur = 4 // (K)
T00 = 80 + 273 // (K)
GS = 1368 // (W/m^2)
Ac = t*W //cross sectional area (m^2)
P = 2*W //perimeter (m)
deltax = 0.1 // (m)
sigma=5.67e-8
    
```

Continued...

## PROBLEM 12.134 (Cont.)

### //Interior nodes, 01 to 09

$$k \cdot \text{Ac} \cdot (T_{00} - T_{01}) / \text{deltax} + k \cdot \text{Ac} \cdot (T_{02} - T_{01}) / \text{deltax} + \text{absS} \cdot \text{GS} \cdot P / 2 \cdot \text{deltax} + \text{eps} \cdot P \cdot \text{deltax} \cdot \text{sigma} \cdot (T_{\text{sur}}^4 - T_{01}^4) = 0$$

$$k \cdot \text{Ac} \cdot (T_{01} - T_{02}) / \text{deltax} + k \cdot \text{Ac} \cdot (T_{03} - T_{02}) / \text{deltax} + \text{absS} \cdot \text{GS} \cdot P / 2 \cdot \text{deltax} + \text{eps} \cdot P \cdot \text{deltax} \cdot \text{sigma} \cdot (T_{\text{sur}}^4 - T_{02}^4) = 0$$

$$k \cdot \text{Ac} \cdot (T_{02} - T_{03}) / \text{deltax} + k \cdot \text{Ac} \cdot (T_{04} - T_{03}) / \text{deltax} + \text{absS} \cdot \text{GS} \cdot P / 2 \cdot \text{deltax} + \text{eps} \cdot P \cdot \text{deltax} \cdot \text{sigma} \cdot (T_{\text{sur}}^4 - T_{03}^4) = 0$$

$$k \cdot \text{Ac} \cdot (T_{03} - T_{04}) / \text{deltax} + k \cdot \text{Ac} \cdot (T_{05} - T_{04}) / \text{deltax} + \text{absS} \cdot \text{GS} \cdot P / 2 \cdot \text{deltax} + \text{eps} \cdot P \cdot \text{deltax} \cdot \text{sigma} \cdot (T_{\text{sur}}^4 - T_{04}^4) = 0$$

$$k \cdot \text{Ac} \cdot (T_{04} - T_{05}) / \text{deltax} + k \cdot \text{Ac} \cdot (T_{06} - T_{05}) / \text{deltax} + \text{absS} \cdot \text{GS} \cdot P / 2 \cdot \text{deltax} + \text{eps} \cdot P \cdot \text{deltax} \cdot \text{sigma} \cdot (T_{\text{sur}}^4 - T_{05}^4) = 0$$

$$k \cdot \text{Ac} \cdot (T_{05} - T_{06}) / \text{deltax} + k \cdot \text{Ac} \cdot (T_{07} - T_{06}) / \text{deltax} + \text{absS} \cdot \text{GS} \cdot P / 2 \cdot \text{deltax} + \text{eps} \cdot P \cdot \text{deltax} \cdot \text{sigma} \cdot (T_{\text{sur}}^4 - T_{06}^4) = 0$$

$$k \cdot \text{Ac} \cdot (T_{06} - T_{07}) / \text{deltax} + k \cdot \text{Ac} \cdot (T_{08} - T_{07}) / \text{deltax} + \text{absS} \cdot \text{GS} \cdot P / 2 \cdot \text{deltax} + \text{eps} \cdot P \cdot \text{deltax} \cdot \text{sigma} \cdot (T_{\text{sur}}^4 - T_{07}^4) = 0$$

$$k \cdot \text{Ac} \cdot (T_{07} - T_{08}) / \text{deltax} + k \cdot \text{Ac} \cdot (T_{09} - T_{08}) / \text{deltax} + \text{absS} \cdot \text{GS} \cdot P / 2 \cdot \text{deltax} + \text{eps} \cdot P \cdot \text{deltax} \cdot \text{sigma} \cdot (T_{\text{sur}}^4 - T_{08}^4) = 0$$

$$k \cdot \text{Ac} \cdot (T_{08} - T_{09}) / \text{deltax} + k \cdot \text{Ac} \cdot (T_{10} - T_{09}) / \text{deltax} + \text{absS} \cdot \text{GS} \cdot P / 2 \cdot \text{deltax} + \text{eps} \cdot P \cdot \text{deltax} \cdot \text{sigma} \cdot (T_{\text{sur}}^4 - T_{09}^4) = 0$$

### //Tip node, 10

$$//k \cdot \text{Ac} \cdot (T_{09} - T_{10}) / \text{deltax} + \text{absS} \cdot \text{GS} \cdot (P/2) \cdot (\text{deltax}/2) + \text{eps} \cdot (P \cdot \text{deltax}/2 + \text{Ac}) \cdot \text{sigma} \cdot (T_{\text{sur}}^4 - T_{10}^4) = 0$$

$$\text{TLC} = T_{10} - 273$$

### //Rejection heat rate, energy balance on base node

$$q_f + k \cdot \text{Ac} \cdot (T_{01} - T_{00}) / \text{deltax} + \text{absS} \cdot \text{GS} \cdot (P/2) \cdot (\text{deltax}/2) + \text{eps} \cdot (P \cdot \text{deltax}/2) \cdot \text{sigma} \cdot (T_{\text{sur}}^4 - T_{00}^4) = 0$$

### //Check

$$q_{fu} = \text{eps} \cdot \text{sigma} \cdot ((80 + 273)^4 - 4^4) \cdot (P \cdot 1 + \text{Ac})$$

(2) To determine the validity of the one-dimensional, extended surface analysis, calculate the Biot number estimating the linearized radiation coefficient based upon the uniform plate condition,  $T_b = 80^\circ\text{C}$ .

$$\text{Bi} = h_{\text{rad}} (t/2) / k$$

$$h_{\text{rad}} = \varepsilon \sigma (T_b + T_{\text{sur}}) (T_b^2 + T_{\text{sur}}^2) \approx \varepsilon \sigma T_b^3 = 2.25 \text{ W} / \text{m}^2 \cdot \text{K}$$

$$\text{Bi} = 2.25 \text{ W} / \text{m}^2 \cdot \text{K} (0.012 \text{ m} / 2) / 300 \text{ W} / \text{m} \cdot \text{K} = 4.5 \times 10^{-5}$$

Since  $\text{Bi} \ll 0.1$ , the assumption of one-dimensional conduction is appropriate.

## PROBLEM 12.135

**KNOWN:** Directional absorptivity of a plate exposed to solar radiation on one side.

**FIND:** (a) Ratio of normal absorptivity to hemispherical emissivity, (b) Equilibrium temperature of plate at  $0^\circ$  and  $75^\circ$  orientation relative to sun's rays.

**SCHEMATIC:**

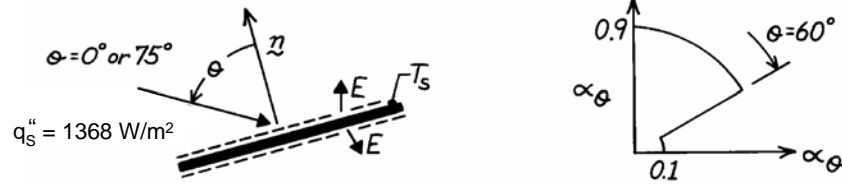

**ASSUMPTIONS:** (1) Surface is gray, (2) Properties are independent of  $\phi$ .

**ANALYSIS:** (a) From the prescribed  $\alpha_\theta(\theta)$ ,  $\alpha_n = 0.9$ . Since the surface is gray,  $\varepsilon_\theta = \alpha_\theta$ . Hence from Eq. 12.42, which applies for total as well as spectral properties.

$$\varepsilon = 2 \int_0^{\pi/2} \varepsilon_\theta \cos \theta \sin \theta d\theta = 2 \left[ 0.9 \frac{\sin^2 \theta}{2} \Big|_0^{\pi/3} + 0.1 \frac{\sin^2 \theta}{2} \Big|_{\pi/3}^{\pi/2} \right]$$

$$\varepsilon = 2 \left[ 0.9(0.375) + 0.1(0.5 - 0.375) \right] = 0.70.$$

Hence

$$\frac{\alpha_n}{\varepsilon} = \frac{0.9}{0.7} = 1.286.$$

(b) Performing an energy balance on the plate,

$$\alpha_\theta q_s'' \cos \theta - 2 \varepsilon \sigma T_s^4 = 0$$

or

$$T_s = \left[ \frac{\alpha_\theta q_s'' \cos \theta}{2 \varepsilon \sigma} \right]^{1/4}.$$

Hence for  $\theta = 0^\circ$ ,  $\alpha_\theta = 0.9$  and  $\cos \theta = 1$ ,

$$T_s = \left[ \frac{0.9}{2 \times 0.7 \times 5.67 \times 10^{-8}} \times 1368 \right]^{1/4} = 353\text{K.} \quad <$$

For  $\theta = 75^\circ$ ,  $\alpha_\theta = 0.1$  and  $\cos \theta = 0.259$

$$T_s = \left[ \frac{0.1}{2 \times 0.7 \times 5.67 \times 10^{-8}} \times 1368 \times 0.259 \right]^{1/4} = 145\text{K.} \quad <$$

**COMMENTS:** Since the surface is not diffuse, its absorptivity depends on the directional distribution of the incident radiation.

### PROBLEM 12.136

**KNOWN:** Transmissivity of cover plate and spectral absorptivity of absorber plate for a solar collector.

**FIND:** Absorption rate for prescribed solar flux and preferred absorber plate coating.

**SCHEMATIC:**

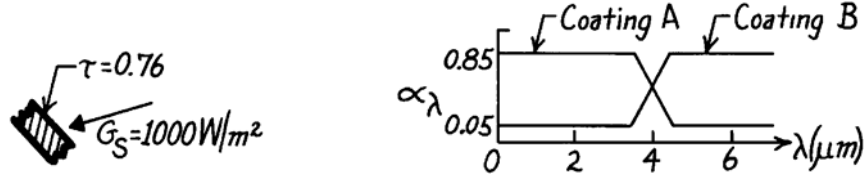

**ASSUMPTIONS:** (1) Solar irradiation of absorber plate retains spectral distribution of blackbody at 5800K, (2) Coatings are diffuse.

**ANALYSIS:** At the absorber plate we wish to maximize solar radiation absorption and minimize losses due to emission. The solar radiation is concentrated in the spectral region  $\lambda < 4\mu\text{m}$ , and for a representative plate temperature of  $T \leq 350\text{K}$ , emission from the plate is concentrated in the spectral region  $\lambda > 4\mu\text{m}$ . Hence,

*Coating A is vastly superior.* <

With  $G_{\lambda,S} \sim E_{\lambda,b}(5800\text{K})$ , it follows from Eq. 12.53

$$\alpha_A \approx 0.85 F_{(0-4\mu\text{m})} + 0.05 F_{(4\mu\text{m}-\infty)}.$$

From Table 12.1,  $\lambda T = 4\mu\text{m} \times 5800\text{K} = 23,200\mu\text{m}\cdot\text{K}$ ,

$$F_{(0-4\mu\text{m})} \approx 0.99.$$

Hence

$$\alpha_A = 0.85(0.99) + 0.05(1 - 0.99) \approx 0.85.$$

With  $G_S = 1000 \text{ W/m}^2$  and  $\tau = 0.84$  (Ex. 12.9), the absorbed solar flux is

$$G_{S,\text{abs}} = \alpha_A (\tau G_S) = 0.85 (0.84 \times 1000 \text{ W/m}^2)$$

$$G_{S,\text{abs}} = 714 \text{ W/m}^2. <$$

**COMMENTS:** Since the absorber plate emits in the infrared ( $\lambda > 4\mu\text{m}$ ), its emissivity is  $\epsilon_A \approx 0.05$ . Hence  $(\alpha/\epsilon)_A = 17$ . A large value of  $\alpha/\epsilon$  is desirable for solar absorbers.

## PROBLEM 12.137

**KNOWN:** Irradiation of satellite from earth and sun. Two emissivities associated with the satellite.

**FIND:** (a) Steady-state satellite temperature when satellite is on bright side of earth for  $\alpha_E/\alpha_s > 1$  and  $\alpha_E/\alpha_s < 1$ , (b) Steady-state satellite temperature when satellite is on dark side of earth for  $\alpha_E/\alpha_s > 1$  and  $\alpha_E/\alpha_s < 1$ , (c) Scheme to minimize temperature variations of the satellite.

**SCHEMATIC:**

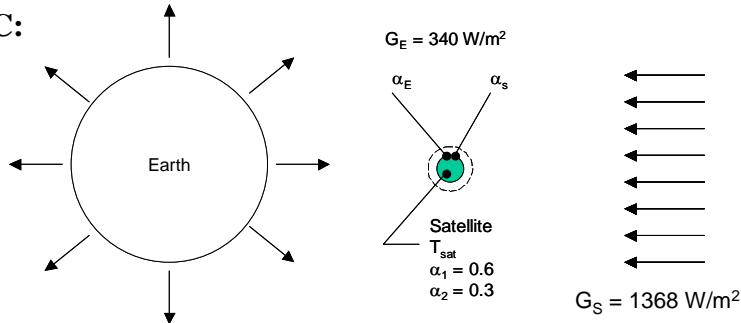

**ASSUMPTIONS:** (1) Steady-state conditions, (2) Opaque, diffuse gray behavior.

**ANALYSIS:** Performing an energy balance on the satellite, it follows that  $\dot{E}_{in} = \dot{E}_{out}$  or

$$\alpha_E G_E (\pi D^2 / 4) + \alpha_s G_s (\pi D^2 / 4) - \epsilon_E \sigma T_{sat}^4 (\pi D^2 / 2) - \epsilon_s \sigma T_{sat}^4 (\pi D^2 / 2) = 0$$

or

$$T_{sat} = \left[ \frac{\alpha_E G_E + \alpha_s G_s}{2(\epsilon_E + \epsilon_s) \sigma} \right]^{1/4}$$

(a) Bright Side of Earth ( $G_s = 1368 \text{ W/m}^2$ ).

For  $\alpha_E = \epsilon_E = \alpha_2 = 0.3$ ,  $\alpha_s = \epsilon_s = \alpha_1 = 0.6$ ,

$$T_{sat} = \left[ \frac{0.3 \times 340 \text{ W/m}^2 + 0.6 \times 1353 \text{ W/m}^2}{2 \times (0.3 + 0.6) \times 5.67 \times 10^{-8} \text{ W/m}^2 \cdot \text{K}^4} \right]^{1/4} = 308 \text{ K} \quad <$$

For  $\alpha_E = \epsilon_E = \alpha_1 = 0.6$ ,  $\alpha_s = \epsilon_s = \alpha_2 = 0.3$ ,

$$T_{sat} = \left[ \frac{0.6 \times 340 \text{ W/m}^2 + 0.3 \times 1353 \text{ W/m}^2}{2 \times (0.6 + 0.3) \times 5.67 \times 10^{-8} \text{ W/m}^2 \cdot \text{K}^4} \right]^{1/4} = 279 \text{ K} \quad <$$

(b) Dark Side of Earth ( $G_s = 0 \text{ W/m}^2$ ).

For  $\alpha_E = \epsilon_E = \alpha_1 = 0.6$ ,  $\alpha_s = \epsilon_s = \alpha_2 = 0.3$ ,

Continued...

**PROBLEM 12.137 (Cont.)**

$$T_{\text{sat}} = \left[ \frac{0.6 \times 340 \text{ W/m}^2}{2 \times (0.6 + 0.3) \times 5.67 \times 10^{-8} \text{ W/m}^2 \cdot \text{K}^4} \right]^{1/4} = 211 \text{ K} \quad <$$

For  $\alpha_E = \varepsilon_E = \alpha_2 = 0.3$ ,  $\alpha_s = \varepsilon_s = \alpha_1 = 0.6$ ,

$$T_{\text{sat}} = \left[ \frac{0.3 \times 340 \text{ W/m}^2}{2 \times (0.3 + 0.6) \times 5.67 \times 10^{-8} \text{ W/m}^2 \cdot \text{K}^4} \right]^{1/4} = 178 \text{ K} \quad <$$

(c) To minimize the temperature variations of the satellite, we would have the high emissivity coating always facing earth.

**COMMENTS:** If the entire satellite were covered with either coating, the temperatures on the bright and dark sides of earth would be  $T_s = 294 \text{ K}$  and  $197 \text{ K}$ , respectively. Use of the two emissivity coatings reduces temperature variations from  $294 \text{ K} - 197 \text{ K} = 97 \text{ K}$  to  $278 \text{ K} - 211 \text{ K} = 67 \text{ K}$ .

## PROBLEM 12.138

**KNOWN:** Space capsule fired from earth orbit platform in direction of sun.

**FIND:** (a) Differential equation predicting capsule temperature as a function of time, (b) Position of capsule relative to sun when it reaches its destruction temperature.

**SCHEMATIC:**

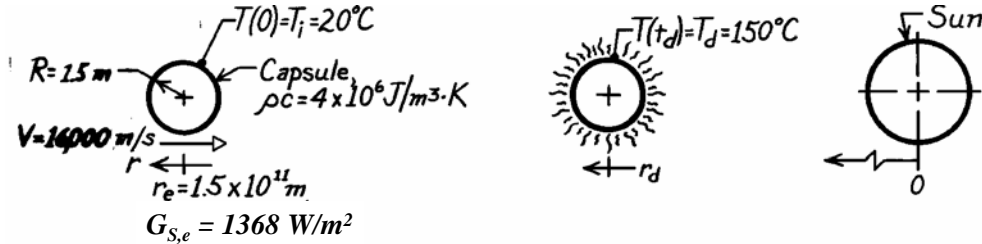

**ASSUMPTIONS:** (1) Capsule behaves as lumped capacitance system, (2) Capsule surface is black, (3) Temperature of surroundings approximates absolute zero, (4) Capsule velocity is constant.

**ANALYSIS:** (a) To find the temperature as a function of time, perform an energy balance on the capsule considering absorbed solar irradiation and emission,

$$\dot{E}_{\text{in}} - \dot{E}_{\text{out}} = \dot{E}_{\text{st}} \quad G_S \cdot \pi R^2 - \sigma T^4 \cdot 4\pi R^2 = \rho c (4/3) \pi R^3 (dT/dt). \quad (1)$$

Note the use of the projected capsule area ( $\pi R^2$ ) and the surface area ( $4\pi R^2$ ). The solar irradiation will increase with decreasing radius (distance toward the sun) as

$$G_S(r) = G_{S,e} (r_e / r)^2 = G_{S,e} (r_e / (r_e - Vt))^2 = G_{S,e} (1 / (1 - Vt / r_e))^2 \quad (2)$$

where  $r_e$  is the distance of earth orbit from the sun and  $r = r_e - Vt$ . Hence, Eq. (1) becomes

$$\frac{dT}{dt} = \frac{3}{\rho c R} \left[ \frac{G_{S,e}}{4(1 - Vt / r_e)^2} - \sigma T^4 \right].$$

The rate of temperature change is

$$\frac{dT}{dt} = \frac{3}{(4 \times 10^6 \text{ J/m}^3 \cdot \text{K} \times 1.5 \text{ m})} \left[ \frac{1368 \text{ W/m}^2}{4(1 - 16 \times 10^3 \text{ m/s} \times t / 1.5 \times 10^{11} \text{ m})^2} - \sigma T^4 \right]$$

$$\frac{dT}{dt} = 1.691 \times 10^{-4} (1 - 1.067 \times 10^{-7} t)^{-2} - 2.835 \times 10^{-14} T^4$$

where  $T[\text{K}]$  and  $t(\text{s})$ . For the initial condition,  $t = 0$ , with  $T = 20^\circ\text{C} = 293\text{K}$ ,

$$\frac{dT}{dt}(0) = -3.9 \times 10^{-5} \text{ K/s.} \quad \leftarrow$$

That is, the capsule will cool for a period of time and then begin to heat.

(b) The differential equation cannot be explicitly solved for temperature as a function of time. Using a numerical method with a time increment of  $\Delta t = 5 \times 10^5 \text{ s}$ , find

$$T(t) = 150^\circ\text{C} = 423 \text{ K} \quad \text{at} \quad t \approx 5.5 \times 10^6 \text{ s.} \quad \leftarrow$$

Note that in this period of time the capsule traveled  $(r_e - r) = Vt = 16 \times 10^3 \text{ m/s} \times 5.5 \times 10^6 = 1.472 \times 10^{10} \text{ m}$ . That is,  $r = 1.353 \times 10^{11} \text{ m}$ .

## PROBLEM 12.139

**KNOWN:** Solar irradiation of coated aluminum. Spectral absorptivities above and below cutoff wavelength. Cutoff wavelength under normal conditions.

**FIND:** (a) Equilibrium temperature for normal conditions with  $\lambda_c = 0.15 \mu\text{m}$ . (b) Value of  $\lambda_c$  that will maximize surface temperature.

**SCHEMATIC:**

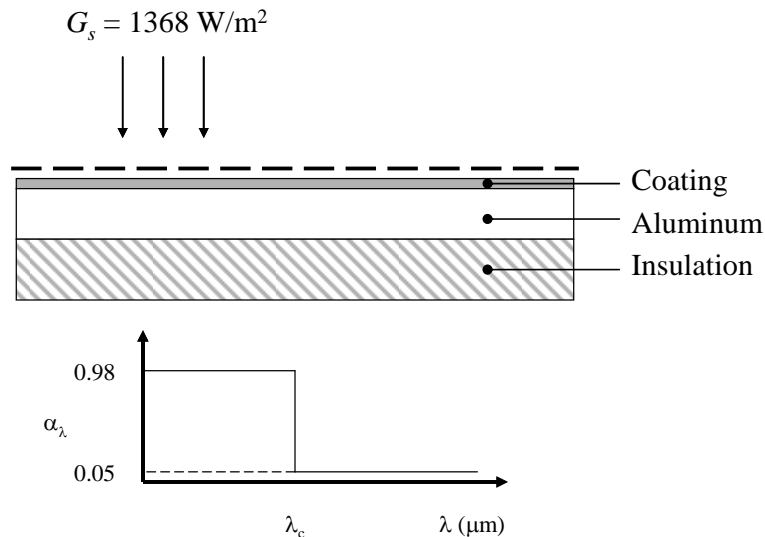

**ASSUMPTIONS:** (1) Steady state conditions. (2) Solar irradiation approximated as that from a blackbody at  $T = 5800 \text{ K}$ .

**ANALYSIS:** (a) For the control surface shown in the schematic  $\dot{E}_{\text{in}} = \dot{E}_{\text{out}}$  or  $G_s = J$  or  $\alpha_s G_s = \varepsilon \sigma T_s^4$ . Therefore,

$$T_s = \left[ \frac{\alpha_s G_s}{\varepsilon \sigma} \right]^{1/4} \quad (1)$$

The solar irradiation is approximated as that of a blackbody at  $5800 \text{ K}$ . From Table 12.1,  $F_{(0-\lambda_c)} = F_{(0-0.15\mu\text{m})} \approx 0$ . Therefore,

$$\alpha_s = \alpha_{\lambda,1} F_{(0-\lambda_c)} + \alpha_{\lambda,2} [1 - F_{(0-\lambda_c)}] = 0.98 \times 0 + 0.05 \times [1 - 0] = 0.05$$

The surface emissivity may be expressed as  $\varepsilon = \alpha_{\lambda,1} F_{(0-\lambda_c \cdot T_s)} + \alpha_{\lambda,2} [1 - F_{(0-\lambda_c \cdot T_s)}]$  (2)

where the variable  $F_{(0-\lambda_c \cdot T_s)}$  is the fraction of blackbody radiation in the band between  $0 \mu\text{m} \cdot \text{K}$  and  $\lambda_c T_s$ . Combining Equations 1 and 2 yields

Continued...



### PROBLEM 12.139 (Cont.)

$$T_s = \left[ \frac{0.05 \times 1368 \text{ W/m}^2}{\left\{ 0.98 \times F_{(0-\lambda_c, T_s)} + 0.05 \times [1 - F_{(0-\lambda_c, T_s)}] \right\} \times 5.67 \times 10^{-8} \text{ W/m}^2 \cdot \text{K}^4} \right]^{1/4}$$

which may be solved by trial-and-error (since  $F_{(0-\lambda_c, T_s)}$  is a function of  $T_s$ ) to yield  $T_s = 394.1 \text{ K}$ . <

Equations 1 and 2 may be solved by trial-and-error to yield a maximum surface temperature of  $T_s = 797 \text{ K}$  at a cutoff wavelength of  $\lambda_c = 1.50 \mu\text{m}$ . <

**COMMENTS:** (1) The small value of  $\lambda_c$  that exists under normal conditions, coupled with the relatively low surface temperature, yields a surface emissivity of 0.05. (2) The emissivity and absorptivity associated with the surface temperature of  $T_s = 797 \text{ K}$  are  $\varepsilon = 0.052$  and  $\alpha = 0.869$ , respectively. (3) The variation of the surface temperature with the cutoff wavelength is shown in the plot below. Manipulation of the cutoff wavelength is an effective approach for achieving desired thermal performance.

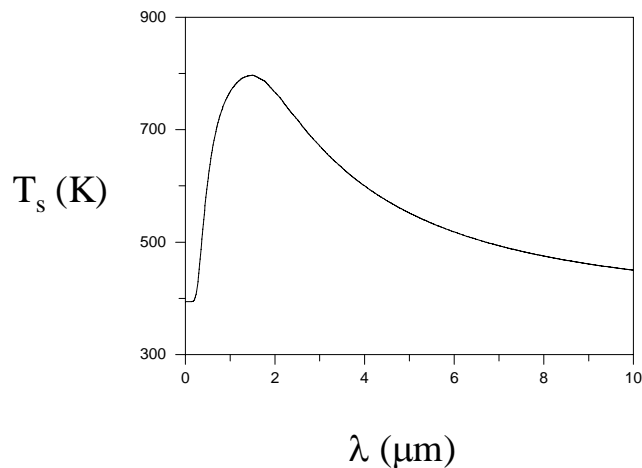

## PROBLEM 12.140

**KNOWN:** Irradiation from the sun and earth on a spherical satellite. Spectral absorptivities of the satellite surface below and above a cutoff wavelength.

**FIND:** (a) Cutoff wavelength to minimize satellite temperature on bright side of earth, corresponding satellite temperature on dark side of earth, (b) Cutoff wavelength to maximize satellite temperature on dark side of earth, corresponding satellite temperature on bright side of earth.

**SCHEMATIC:**

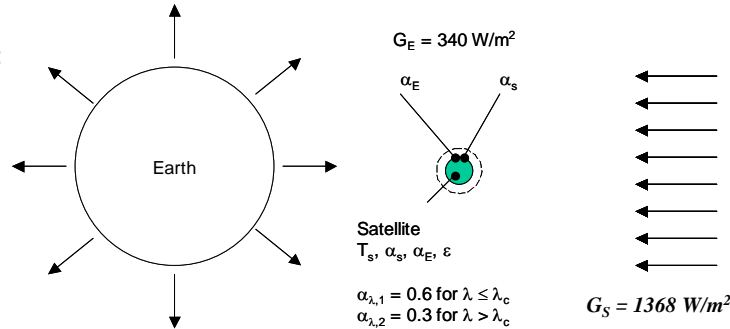

**ASSUMPTIONS:** (1) Steady-state conditions, (2) Opaque, diffuse satellite surface.

**ANALYSIS:** Performing an energy balance on the satellite, it follows that  $\dot{E}_{in} = \dot{E}_{out}$  or

$$\alpha_E G_E (\pi D^2 / 4) + \alpha_s G_s (\pi D^2 / 4) - \epsilon \sigma T_s^4 (\pi D^2) = 0$$

or

$$T_s = \left[ \frac{\alpha_E G_E + \alpha_s G_s}{4 \epsilon \sigma} \right]^{1/4} \quad (1)$$

(a) Bright Side of Earth, Minimize  $T_s$ .

For earth irradiation being approximated as that of a blackbody at 280 K,

$$\alpha_E = \alpha_{\lambda,1} F_{(0-\lambda_c, 280K)} + \alpha_{\lambda,2} [1 - F_{(0-\lambda_c, 280K)}] \quad (2)$$

For solar irradiation being approximated as that of a blackbody at 5800K,

$$\alpha_s = \alpha_{\lambda,1} F_{(0-\lambda_c, 5800K)} + \alpha_{\lambda,2} [1 - F_{(0-\lambda_c, 5800K)}] \quad (3)$$

The satellite emissivity is, with  $\epsilon_\lambda = \alpha_\lambda$ ,  $\epsilon = \alpha_{\lambda,1} F_{(0-\lambda_c, T_s)} + \alpha_{\lambda,2} [1 - F_{(0-\lambda_c, T_s)}]$  (4)

Equations 1 through 4 may be solved using various  $\lambda_c$  yielding a minimum satellite temperature of  $T_s = 295 \text{ K}$  for  $\lambda_c = 0$  or  $\infty$ .

<  
Continued...

## PROBLEM 12.140 (Cont.)

(a) Dark Side of Earth, Maximize  $T_s$ .

For the satellite on the dark side of earth with a spectrally-selective coating, Equation 1 becomes

$$T_s = \left[ \frac{\alpha_E G_E}{4\epsilon\sigma} \right]^{1/4} \quad (5)$$

Equations 2 through 5 may be solved using various  $\lambda_c$ , yielding a maximum satellite temperature of  $T_s = 205 \text{ K}$  at  $\lambda_c = 13.57 \text{ }\mu\text{m}$ . <

The corresponding values of  $\alpha_E$ ,  $\alpha_s$  and  $\epsilon$  are 0.4330, 0.5999 and 0.3672, respectively.

When the satellite is on the bright side with  $\lambda_c = 13.57 \text{ }\mu\text{m}$ , the satellite temperature may be found by solving Equations 1 through 4 yielding a temperature of  $T_s = 310.4 \text{ K}$ . The corresponding values of  $\alpha_E$ ,  $\alpha_s$  and  $\epsilon$  are 0.4330, 0.5999 and 0.4554, respectively. <

**COMMENT:** In part (a) of the problem the satellite temperature is very sensitive to the cutoff wavelength of  $\lambda_c = 0$  when the satellite is on the bright side of earth. This is because of the presence of a significant amount of solar irradiation at relatively short wavelengths.

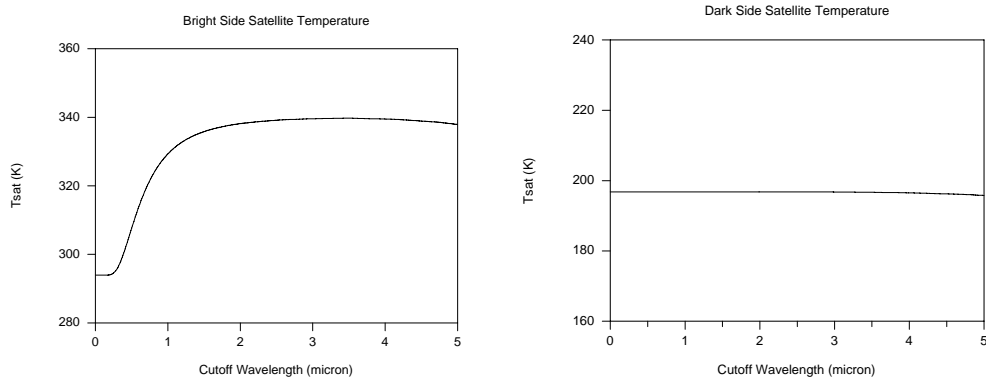

For part (b) of the problem, the dark side satellite temperature is relatively insensitive to the cutoff wavelength because of the similar spectral distributions of the earth irradiation and the satellite emission. In contrast, however, the temperature of the satellite on the bright side of earth is much more sensitive to the cutoff wavelength because of the presence of significant irradiation from the sun at short wavelengths.

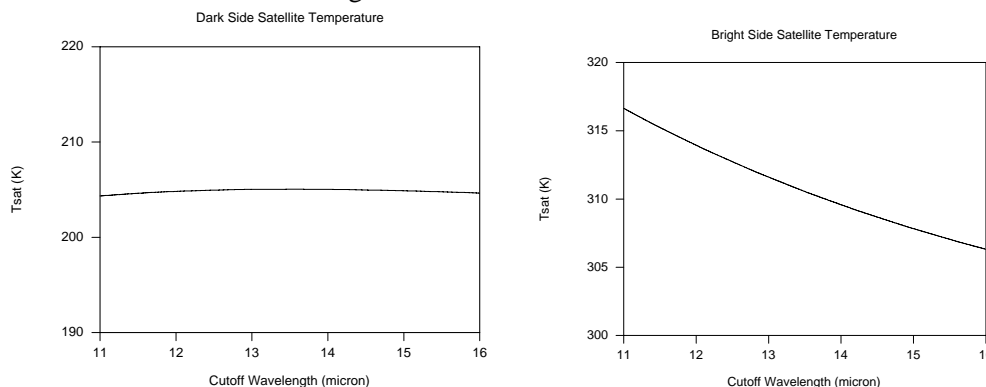

## PROBLEM 12.141

**KNOWN:** Solar panel mounted on a spacecraft of area  $1 \text{ m}^2$  having a solar-to-electrical power conversion efficiency of 12% with specified radiative properties.

**FIND:** (a) Steady-state temperature of the solar panel and electrical power produced with solar irradiation of  $1500 \text{ W/m}^2$ , (b) Steady-state temperature if the panel were a thin plate (no solar cells) with the same radiative properties and for the same prescribed conditions, and (c) Temperature of the solar panel 1500 s after the spacecraft is eclipsed by a planet; thermal capacity of the panel per unit area is  $9000 \text{ J/m}^2 \cdot \text{K}$ .

**SCHEMATIC:**

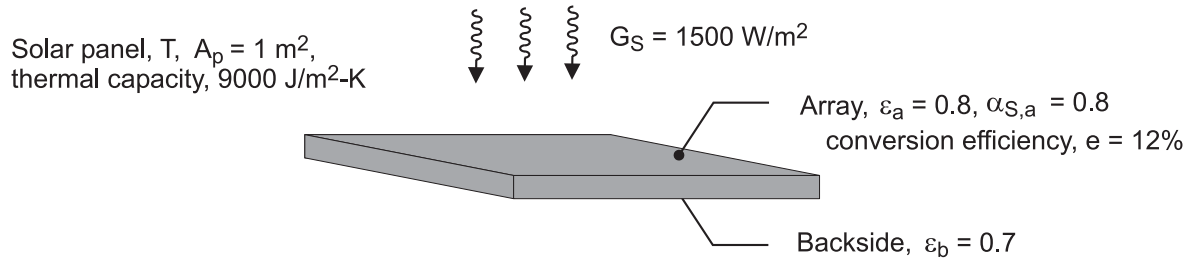

**ASSUMPTIONS:** (1) Solar panel and thin plate are isothermal, (2) Solar irradiation is normal to the panel upper surface, and (3) Panel has unobstructed view of deep space at 0 K.

**ANALYSIS:** (a) The energy balance on the solar panel is represented in the schematic below and has the form

$$\dot{E}_{\text{in}} - \dot{E}_{\text{out}} = 0$$

$$\alpha_S G_S \cdot A_p - (\varepsilon_a + \varepsilon_b) E_b(T_{\text{sp}}) \cdot A_p - P_{\text{elec}} = 0 \quad (1)$$

where  $E_b(T) = \sigma T^4$ ,  $\sigma = 5.67 \times 10^{-8} \text{ W/m}^2 \cdot \text{K}^4$ , and the electrical power produced is

$$P_{\text{elec}} = e \cdot G_S \cdot A_p \quad (2)$$

$$P_{\text{elec}} = 0.12 \times 1500 \text{ W/m}^2 \times 1 \text{ m}^2 = 180 \text{ W} \quad <$$

Substituting numerical values into Eq. (1), find

$$0.8 \times 1500 \text{ W/m}^2 \times 1 \text{ m}^2 - (0.8 + 0.7) \sigma T_{\text{sp}}^4 \times 1 \text{ m}^2 - 180 \text{ W} = 0$$

$$T_{\text{sp}} = 330.9 \text{ K} = 57.9^\circ \text{C} \quad <$$

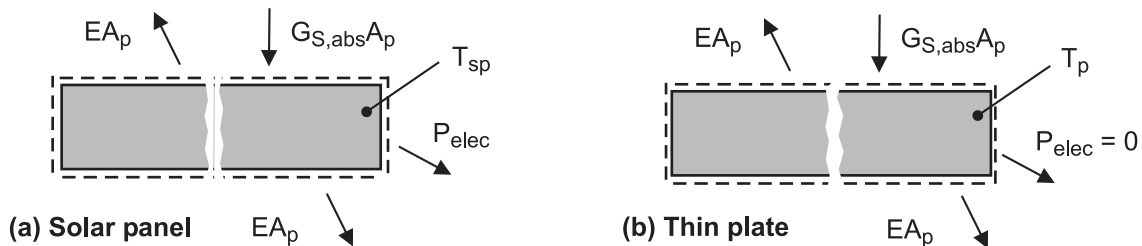

(b) The energy balance for the thin plate shown in the schematic above follows from Eq. (1) with  $P_{\text{elec}} = 0$  yielding

$$0.8 \times 1500 \text{ W/m}^2 \times 1 \text{ m}^2 - (0.8 + 0.7) \sigma T_p^4 \times 1 \text{ m}^2 = 0 \quad (3)$$

$$T_p = 344.7 \text{ K} = 71.7^\circ \text{C} \quad <$$

Continued ...

### PROBLEM 12.141 (Cont.)

(c) Using the lumped capacitance method, the energy balance on the solar panel as illustrated in the schematic below has the form

$$\dot{E}_{\text{in}} - \dot{E}_{\text{out}} = \dot{E}_{\text{st}}$$

$$-(\varepsilon_a + \varepsilon_b) \sigma T_{\text{sp}}^4 \cdot A_p = TC'' \cdot A_p \frac{dT_{\text{sp}}}{dt} \quad (4)$$

where the thermal capacity per unit area is  $TC'' = (Mc / A_p) = 9000 \text{ J} / \text{m}^2 \cdot \text{K}$ .

Eq. 5.18 provides the solution to this differential equation in terms of  $t = t(T_i, T_{\text{sp}})$ . Alternatively, use Eq. (4) in the *IHT* workspace (see Comment 4 below) to find

$$T_{\text{sp}}(1500 \text{ s}) = 242.6 \text{ K} = -30.4^\circ \text{C} \quad <$$

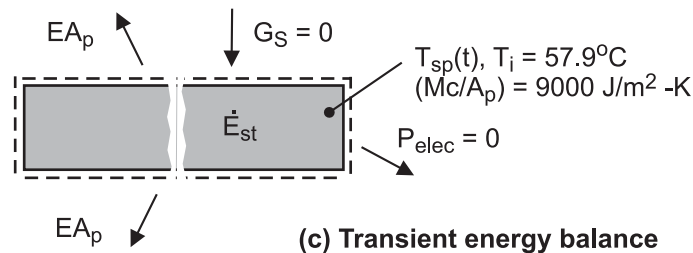

**COMMENTS:** (1) For part (a), the energy balance could be written as

$$\dot{E}_{\text{in}} - \dot{E}_{\text{out}} + \dot{E}_{\text{g}} = 0$$

where the energy generation term represents the *conversion process from thermal energy to electrical energy*. That is,

$$\dot{E}_{\text{g}} = -e \cdot G_S \cdot A_p$$

(2) The steady-state temperature for the thin plate, part (b), is higher than for the solar panel, part (a). This is to be expected since, for the solar panel, some of the absorbed solar irradiation (thermal energy) is converted to electrical power.

(3) To justify use of the lumped capacitance method for the transient analysis, we need to know the effective thermal conductivity or internal thermal resistance of the solar panel.

(4) Selected portions of the *IHT* code using the *Models Lumped | Capacitance* tool to perform the transient analysis based upon Eq. (4) are shown below.

```
// Energy balance, Model | Lumped Capacitance
/* Conservation of energy requirement on the control volume, CV. */
Edotin - Edotout = Edotst
Edotin = 0
Edotout = Ap * (+q"rad)
Edostat = rhovolcp * Ap * Der(T,t)
// rhovolcp = rho * vol * cp // thermal capacitance per unit area, J/m^2-K

// Radiation exchange between Cs and large surroundings
q"rad = (eps_a + eps_b) * sigma * (T^4 - Tsur^4)
sigma = 5.67e-8 // Stefan-Boltzmann constant, W/m^2-K^4

// Initial condition
// Ti = 57.93 + 273 = 330.9 // From part (a), steady-state condition
T_C = T - 273
```

(5) The solar flux exceeds the solar constant value of  $1368 \text{ W/m}^2$ . Hence the spacecraft is closer to the sun than is earth.

## PROBLEM 12.142

**KNOWN:** Effective sky temperature and convection heat transfer coefficient associated with a thin layer of water.

**FIND:** Lowest air temperature for which the water will not freeze (without and with evaporation).

**SCHEMATIC:**

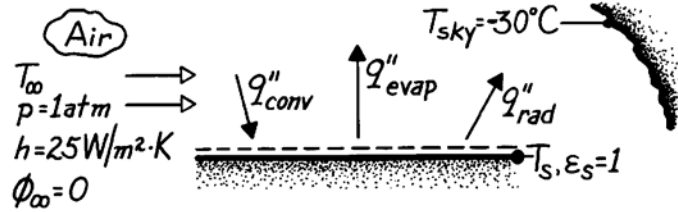

**ASSUMPTIONS:** (1) Steady-state conditions, (2) Bottom of water is adiabatic, (3) Heat and mass transfer analogy is applicable, (4) Air is dry.

**PROPERTIES:** Table A-4, Air (273 K, 1 atm):  $\rho = 1.287 \text{ kg/m}^3$ ,  $c_p = 1.01 \text{ kJ/kg}\cdot\text{K}$ ,  $\nu = 13.49 \times 10^{-6} \text{ m}^2/\text{s}$ ,  $\text{Pr} = 0.72$ ; Table A-6, Saturated vapor ( $T_s = 273 \text{ K}$ ):  $\rho_A = 4.8 \times 10^{-3} \text{ kg/m}^3$ ,  $h_{fg} = 2502 \text{ kJ/kg}$ ; Table A-8, Vapor-air (298 K):  $D_{AB} \approx 0.36 \times 10^{-4} \text{ m}^2/\text{s}$ ,  $\text{Sc} = \nu/D_{AB} = 0.52$ .

**ANALYSIS:** Without evaporation, the surface heat loss by radiation must be balanced by heat gain due to convection. An energy balance gives

$$q''_{\text{conv}} = q''_{\text{rad}} \quad \text{or} \quad h(T_\infty - T_s) = \epsilon_s \sigma (T_s^4 - T_{\text{sky}}^4).$$

At freezing,  $T_s = 273 \text{ K}$ . Hence

$$T_\infty = T_s + \frac{\epsilon_s \sigma}{h} (T_s^4 - T_{\text{sky}}^4) = 273 \text{ K} + \frac{5.67 \times 10^{-8} \text{ W/m}^2 \cdot \text{K}^4}{25 \text{ W/m}^2 \cdot \text{K}} [274^4 - 243^4] \text{ K}^4 = 4.69^\circ\text{C}. \quad <$$

With evaporation, the surface energy balance is now

$$q''_{\text{conv}} = q''_{\text{evap}} + q''_{\text{rad}} \quad \text{or} \quad h(T_\infty - T_s) = h_m [\rho_{A,\text{sat}}(T_s) - \rho_{A,\infty}] h_{fg} + \epsilon_s \sigma (T_s^4 - T_{\text{sky}}^4).$$

$$T_\infty = T_s + \frac{h_m}{h} \rho_{A,\text{sat}}(T_s) h_{fg} + \frac{\epsilon_s \sigma}{h} (T_s^4 - T_{\text{sky}}^4).$$

Substituting from Eq. 6.60, with  $n \approx 0.33$ ,

$$\begin{aligned} h_m / h &= \left( \rho c_p \text{Le}^{0.67} \right)^{-1} = \left[ \rho c_p (\text{Sc} / \text{Pr})^{0.67} \right]^{-1} \\ &= \left[ 1.287 \text{ kg/m}^3 \times 1010 \text{ J/kg}\cdot\text{K} (0.52 / 0.72)^{0.67} \right]^{-1} \\ &= 9.57 \times 10^{-4} \text{ m}^3 \cdot \text{K} / \text{J}, \end{aligned}$$

$$T_\infty = 273 \text{ K} + 9.57 \times 10^{-4} \text{ m}^3 \cdot \text{K} / \text{J} \times 4.8 \times 10^{-3} \text{ kg/m}^3 \times 2.5 \times 10^6 \text{ J/kg} + 4.69 \text{ K} = 16.2^\circ\text{C}. \quad <$$

**COMMENTS:** The existence of clear, cold skies and dry air will allow water to freeze for ambient air temperatures well above  $0^\circ\text{C}$  (due to radiative and evaporative cooling effects, respectively). The lowest air temperature for which the water will not freeze increases with decreasing  $\phi_\infty$ , decreasing  $T_{\text{sky}}$  and decreasing  $h$ .

### PROBLEM 12.143

**KNOWN:** Temperature and environmental conditions associated with a shallow layer of water.

**FIND:** Whether water temperature will increase or decrease with time.

**SCHEMATIC:**

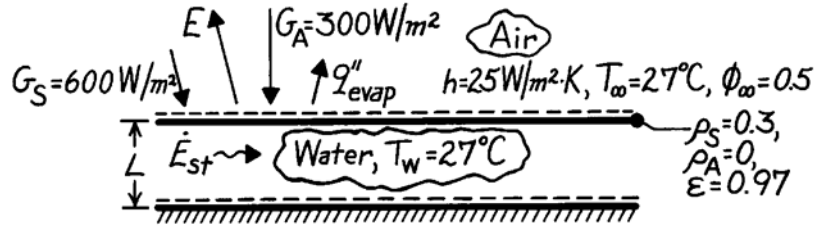

**ASSUMPTIONS:** (1) Water layer is well mixed (uniform temperature), (2) All non-reflected radiation is absorbed by water, (3) Bottom is adiabatic, (4) Heat and mass transfer analogy is applicable, (5) Perfect gas behavior for water vapor.

**PROPERTIES:** Table A-4, Air ( $T = 300 \text{ K}$ , 1 atm):  $\rho_a = 1.161 \text{ kg/m}^3$ ,  $c_{p,a} = 1007 \text{ J/kg}\cdot\text{K}$ ,  $\text{Pr} = 0.707$ ; Table A-6, Water ( $T = 300 \text{ K}$ , 1 atm):  $\rho_w = 997 \text{ kg/m}^3$ ,  $c_{p,w} = 4179 \text{ J/kg}\cdot\text{K}$ ; Vapor ( $T = 300 \text{ K}$ , 1 atm):  $\rho_{A,\text{sat}} = 0.0256 \text{ kg/m}^3$ ,  $h_{fg} = 2.438 \times 10^6 \text{ J/kg}$ ; Table A-8, Water vapor-air ( $T = 300 \text{ K}$ , 1 atm):  $D_{AB} \approx 0.26 \times 10^{-4} \text{ m}^2/\text{s}$ ; with  $v_a = 15.89 \times 10^{-6} \text{ m}^2/\text{s}$  from Table A-4,  $\text{Sc} = v_a/D_{AB} = 0.61$ .

**ANALYSIS:** Performing an energy balance on a control volume about the water,

$$\dot{E}_{st} = (G_{S,\text{abs}} + G_{A,\text{abs}} - E - q''_{\text{evap}})A$$

$$\frac{d(\rho_w c_{p,w} L A T_w)}{dt} = \left[ (1 - \rho_s) G_S + (1 - \rho_A) G_A - \epsilon \sigma T_w^4 - h_m h_{fg} (\rho_{A,\text{sat}} - \rho_{A,\infty}) \right] A$$

or, with  $T_\infty = T_w$ ,  $\rho_{A,\infty} = \phi_\infty \rho_{A,\text{sat}}$  and

$$\rho_w c_{p,w} L \frac{dT_w}{dt} = (1 - \rho_s) G_S + (1 - \rho_A) G_A - \epsilon \sigma T_w^4 - h_m h_{fg} (1 - \phi_\infty) \rho_{A,\text{sat}}$$

From Eq. 6.60, with a value of  $n = 1/3$ ,

$$h_m = \frac{h}{\rho_a c_{p,a} \text{Le}^{1-n}} = \frac{h}{\rho_a c_{p,a} (\text{Sc}/\text{Pr})^{1-n}} = \frac{25 \text{ W/m}^2 \cdot \text{K} (0.707)^{2/3}}{1.161 \text{ kg/m}^3 \times 1007 \text{ J/kg} \cdot \text{K} (0.61)^{2/3}} = 0.0236 \text{ m/s}.$$

Hence

$$\rho_w c_{p,w} L \frac{dT_w}{dt} = (1 - 0.3) 600 + (1 - 0) 300 - 0.97 \times 5.67 \times 10^{-8} (300)^4 - 0.0236 \times 2.438 \times 10^6 (1 - 0.5) 0.0256$$

$$\rho_w c_{p,w} L \frac{dT_w}{dt} = (420 + 300 - 445 - 736) \text{ W/m}^2 = -461 \text{ W/m}^2.$$

Hence the water will *cool*. <

**COMMENTS:** (1) Since  $T_w = T_\infty$  for the prescribed conditions, there is no convection of sensible energy. However, as the water cools, there will be convection heat transfer from the air. (2) If  $L = 1 \text{ m}$ ,  $(dT_w/dt) = -461/(997 \times 4179 \times 1) = -1.11 \times 10^{-4} \text{ K/s}$ .

## PROBLEM 12.144

**KNOWN:** Environmental conditions for a metal roof with and without a water film.

**FIND:** Roof surface temperature (a) without the film, (b) with the film.

**SCHEMATIC:**

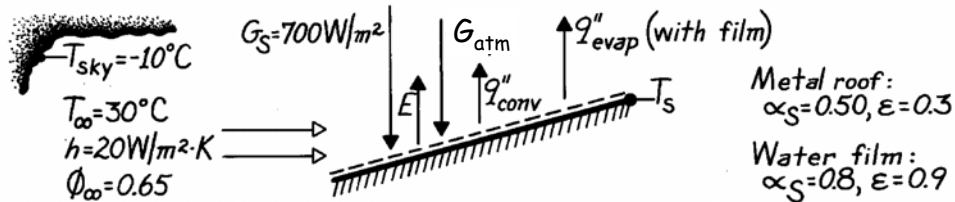

**ASSUMPTIONS:** (1) Steady-state conditions, (2) Diffuse-gray surface behavior in the infrared (for the metal,  $\alpha_{\text{sky}} = \varepsilon = 0.3$ ; for the water,  $\alpha_{\text{sky}} = \varepsilon = 0.9$ ), (3) Adiabatic roof bottom, (4) Perfect gas behavior for vapor.

**PROPERTIES:** Table A-4, Air ( $T \approx 300$  K):  $\rho = 1.16$  kg/m<sup>3</sup>,  $c_p = 1007$  J/kg·K,  $\alpha = 22.5 \times 10^{-6}$  m<sup>2</sup>/s; Table A-6, Water vapor ( $T \approx 303$  K):  $v_g = 32.4$  m<sup>3</sup>/kg or  $\rho_{A,\text{sat}} = 0.031$  kg/m<sup>3</sup>; Table A-8, Water vapor-air ( $T = 298$  K):  $D_{AB} = 0.26 \times 10^{-4}$  m<sup>2</sup>/s.

**ANALYSIS:** (a) From an energy balance on the metal roof

$$\begin{aligned} \alpha_S G_S + \alpha_{\text{sky}} G_{\text{atm}} &= E + q''_{\text{conv}} \\ 0.5(700 \text{ W/m}^2) + 0.3 \times 5.67 \times 10^{-8} \text{ W/m}^2 \cdot \text{K}^4 (263 \text{ K})^4 \\ &= 0.3 \times 5.67 \times 10^{-8} \text{ W/m}^2 \cdot \text{K}^4 (T_S^4) + 20 \text{ W/m}^2 \cdot \text{K} (T_S - 303 \text{ K}) \\ 431 \text{ W/m}^2 &= 1.70 \times 10^{-8} T_S^4 + 20(T_S - 303). \end{aligned} \quad <$$

From a trial-and-error solution,  $T_S = 316.1$  K = 43.1°C.

(b) From an energy balance on the water film,

$$\begin{aligned} \alpha_S G_S + \alpha_{\text{sky}} G_{\text{atm}} &= E + q''_{\text{conv}} + q''_{\text{evap}} \\ 0.8(700 \text{ W/m}^2) + 0.9 \times 5.67 \times 10^{-8} \text{ W/m}^2 \cdot \text{K}^4 (263 \text{ K})^4 &= 0.9 \times 5.67 \times 10^{-8} \text{ W/m}^2 \cdot \text{K}^4 (T_S^4) \\ &+ 20 \text{ W/m}^2 \cdot \text{K} (T_S - 303) + h_m (\rho_{A,\text{sat}}(T_S) - 0.65 \times 0.031 \text{ kg/m}^3) h_{\text{fg}}. \end{aligned}$$

From Eq. 6.60, assuming  $n = 0.33$ ,

$$\begin{aligned} h_m &= \frac{h}{\rho c_p \text{Le}^{0.67}} = \\ \frac{h}{\rho c_p (\alpha / D_{AB})^{0.67}} &= \frac{20 \text{ W/m}^2 \cdot \text{K}}{1.16 \text{ kg/m}^3 \times 1007 \text{ J/kg} \cdot \text{K} (0.225 \times 10^{-4} / 0.260 \times 10^{-4})^{0.67}} = 0.019 \text{ m/s}. \end{aligned}$$

$$804 \text{ W/m}^2 = 5.10 \times 10^{-8} T_S^4 + 20(T_S - 303) + 0.019 [\rho_{A,\text{sat}}(T_S) - 0.020] h_{\text{fg}}.$$

From a trial-and-error solution, obtaining  $\rho_{A,\text{sat}}(T_S)$  and  $h_{\text{fg}}$  from Table A-6 for each assumed value of  $T_S$ , it follows that

$$T_S = 302.2 \text{ K} = 29.2^\circ\text{C}. \quad <$$

**COMMENTS:** (1) The film is an effective coolant, reducing  $T_S$  by 13.9°C. (2) With the film  $E \approx 425$  W/m<sup>2</sup>,  $q''_{\text{conv}} \approx -16$  W/m<sup>2</sup> and  $q''_{\text{evap}} \approx 428$  W/m<sup>2</sup>.



## PROBLEM 12.145

**KNOWN:** Solar, sky and ground irradiation of a wet towel. Towel dimensions, emissivity and solar absorptivity. Temperature, relative humidity and convection heat transfer coefficient associated with air flow over the towel.

**FIND:** Temperature of towel and evaporation rate.

**SCHEMATIC:**

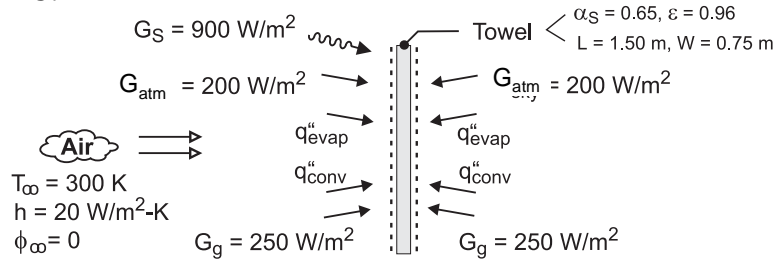

**ASSUMPTIONS:** (1) Steady-state, (2) Diffuse-gray surface behavior of towel in the infrared ( $\alpha_{\text{sky}} = \alpha_g = \epsilon = 0.96$ ), (3) Perfect gas behavior for vapor.

**PROPERTIES:** Table A-4, Air ( $T \approx 300$  K):  $\rho = 1.16$  kg/m<sup>3</sup>,  $c_p = 1007$  J/kg·K,  $\alpha = 0.225 \times 10^{-4}$  m<sup>2</sup>/s; Table A-6, Water vapor ( $T_\infty = 300$  K):  $\rho_{A,\text{sat}} = 0.0256$  kg/m<sup>3</sup>; Table A-8, Water vapor/air ( $T = 298$  K):  $D_{AB} = 0.26 \times 10^{-4}$  m<sup>2</sup>/s.

**ANALYSIS:** From an energy balance on the towel, it follows that

$$\begin{aligned} \alpha_S G_S + 2\alpha_{\text{sky}} G_{\text{atm}} + 2\alpha_g G_g &= 2E + 2q''_{\text{evap}} + 2q''_{\text{conv}} \\ 0.65 \times 900 \text{ W/m}^2 + 2 \times 0.96 \times 200 \text{ W/m}^2 + 2 \times 0.96 \times 250 \text{ W/m}^2 &= 2 \times 0.96 \sigma T_s^4 + 2n''_A h_{fg} + 2h(T_s - T_\infty) \end{aligned} \quad (1)$$

where  $n''_A = h_m [\rho_{A,\text{sat}}(T_s) - \phi_\infty \rho_{A,\text{sat}}(T_\infty)]$

From the heat and mass transfer analogy, Eq. 6.60, with an assumed exponent of  $n = 1/3$ ,

$$h_m = \frac{h}{\rho c_p (\alpha / D_{AB})^{2/3}} = \frac{20 \text{ W/m}^2 \cdot \text{K}}{1.16 \text{ kg/m}^3 (1007 \text{ J/kg} \cdot \text{K}) \left( \frac{0.225}{0.260} \right)^{2/3}} = 0.0189 \text{ m/s}$$

From a trial-and-error solution, we find that for  $T_s = 298$  K,  $\rho_{A,\text{sat}} = 0.0226$  kg/m<sup>3</sup>,  $h_{fg} = 2.442 \times 10^6$  J/kg and  $n''_A = 1.380 \times 10^{-4}$  kg/s·m<sup>2</sup>. Substituting into Eq. (1),

$$\begin{aligned} (585 + 384 + 480) \text{ W/m}^2 &= 2 \times 0.96 \times 5.67 \times 10^{-8} \text{ W/m}^2 \cdot \text{K}^4 (298 \text{ K})^4 \\ &+ 2 \times 1.380 \times 10^{-4} \text{ kg/s} \cdot \text{m}^2 \times 2.442 \times 10^6 \text{ J/kg} \\ &+ 2 \times 20 \text{ W/m}^2 \cdot \text{K} (-2 \text{ K}) \\ 1449 \text{ W/m}^2 &= (859 + 674 - 80) \text{ W/m}^2 = 1453 \text{ W/m}^2 \end{aligned}$$

The equality is satisfied to a good approximation, in which case

$$T_s \approx 298 \text{ K} = 25^\circ\text{C} \quad <$$

$$\text{and } n_A = 2 A_s n''_A = 2(1.50 \times 0.75) \text{ m}^2 (1.38 \times 10^{-4} \text{ kg/s} \cdot \text{m}^2) = 3.11 \times 10^{-4} \text{ kg/s} \quad <$$

**COMMENTS:** Note that the temperature of the air exceeds that of the towel, in which case convection heat transfer is to the towel. Reduction of the towel's temperature below that of the air is due to the evaporative cooling effect.

## PROBLEM 12.146

**KNOWN:** Wet paper towel experiencing forced convection heat and mass transfer and irradiation from radiant lamps. Prescribed convection parameters including wet and dry bulb temperature of the air stream,  $T_{wb}$  and  $T_{\infty}$ , average heat and mass transfer coefficients,  $\bar{h}$  and  $\bar{h}_m$ . Towel temperature  $T_s$ .

**FIND:** (a) Vapor densities,  $\rho_{A,s}$  and  $\rho_{A,\infty}$ ; the evaporation rate  $n_A$  (kg/s); and the net rate of radiation transfer to the towel  $q_{rad}$  (W); and (b) Emissive power  $E$ , the irradiation  $G$ , and the radiosity  $J$ , using the results from part (a).

**SCHEMATIC:**

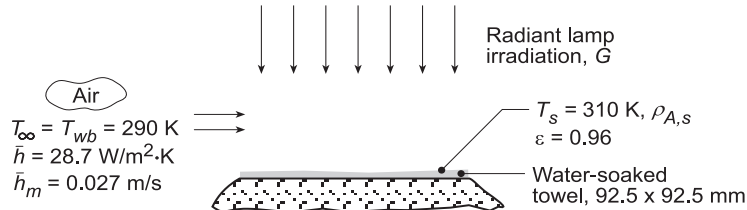

**ASSUMPTIONS:** (1) Steady-state conditions, (2) Negligible heat loss from the bottom side of the towel, (3) Uniform irradiation on the towel, and (4) Water surface is diffuse, gray.

**PROPERTIES:** Table A.6, Water ( $T_s = 310$  K):  $h_{fg} = 2414$  kJ/kg.

**ANALYSIS:** (a) Since  $T_{wb} = T_{\infty}$ , the free stream contains water vapor at its saturation condition. The water vapor at the surface is saturated since it is in equilibrium with the liquid in the towel. From Table A.6,

$T$ (K)	$v_g$ ( $m^3/kg$ )	$\rho_g$ ( $kg/m^3$ )
$T_{\infty} = 290$	69.7	$\rho_{A,\infty} = 1.435 \times 10^{-2}$
$T_s = 310$	22.93	$\rho_{A,s} = 4.361 \times 10^{-2}$

Using the mass transfer convection rate equation, the water evaporation rate from the towel is

$$n_A = \bar{h}_m A_s (\rho_{A,s} - \rho_{A,\infty}) = 0.027 \text{ m/s} (0.0925 \text{ m})^2 (4.361 - 1.435) \times 10^{-2} \text{ kg/m}^3 = 6.76 \times 10^{-6} \text{ kg/s} <$$

To determine the net radiation heat rate  $q_{rad}''$ , perform an energy balance on the water film,

$$\dot{E}_{in} - \dot{E}_{out} = 0 \quad q_{rad} - q_{cv} - q_{evap} = 0$$

$$q_{rad} = q_{cv} + q_{evap} = \bar{h}_s A_s (T_s - T_{\infty}) + n_A h_{fg}$$

and substituting numerical values find

$$q_{rad} = 28.7 \text{ W/m}^2 \cdot \text{K} (0.0925 \text{ m})^2 (310 - 290) \text{ K} + 6.76 \times 10^{-6} \text{ kg/s} \times 2414 \times 10^3 \text{ J/kg}$$

$$q_{rad} = (4.91 + 16.32) \text{ W} = 21.2 \text{ W} <$$

(b) The radiation parameters for the towel surface are now evaluated. The emissive power is

$$E = \epsilon E_b (T_s) = \epsilon \sigma T_s^4 = 0.96 \times 5.67 \times 10^{-8} \text{ W/m}^2 \cdot \text{K}^4 (310 \text{ K})^4 = 502.7 \text{ W/m}^2 <$$

To determine the irradiation  $G$ , recognize that the net radiation heat rate can be expressed as,

$$q_{rad} = (\alpha G - E) A_s \quad 21.2 \text{ W} = (0.96 G - 502.7) \text{ W/m}^2 \times (0.0925 \text{ m})^2 \quad G = 3105 \text{ W/m}^2 <$$

where  $\alpha = \epsilon$  since the water surface is diffuse, gray. From the definition of the radiosity,

$$J = E + \rho G = [502.7 + (1 - 0.96) \times 3105] \text{ W/m}^2 = 626.9 \text{ W/m}^2 <$$

where  $\rho = 1 - \alpha = 1 - \epsilon$ .

**COMMENTS:** An alternate method to evaluate  $J$  is to recognize that  $q_{rad}'' = G - J$ .

### PROBLEM 13.1

**KNOWN:** Various geometric shapes involving two areas  $A_1$  and  $A_2$ .

**FIND:** Shape factors,  $F_{12}$  and  $F_{21}$ , for each configuration.

**ASSUMPTIONS:** Surfaces are diffuse.

**ANALYSIS:** The analysis is not to make use of tables or charts. The approach involves use of the reciprocity relation, Eq. 13.3, and summation rule, Eq. 13.4. Recognize that reciprocity applies to two surfaces; summation applies to an enclosure. Certain shape factors will be identified by inspection. Note  $L$  is the length normal to page.

(a) Long duct (L):

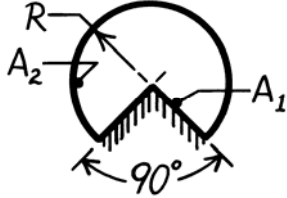

By inspection,  $F_{12} = 1.0$  <

By reciprocity,  $F_{21} = \frac{A_1}{A_2} F_{12} = \frac{2RL}{(3/4) \cdot 2\pi RL} \times 1.0 = \frac{4}{3\pi} = 0.424$  <

(b) Small sphere,  $A_1$ , under concentric hemisphere,  $A_2$ , where  $A_2 = 2A_1$

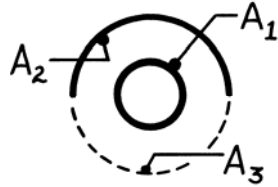

Summation rule  $F_{11} + F_{12} + F_{13} = 1$

But  $F_{12} = F_{13}$  by symmetry, hence  $F_{12} = 0.50$  <

By reciprocity,  $F_{21} = \frac{A_1}{A_2} F_{12} = \frac{A_1}{2A_1} \times 0.5 = 0.25$ . <

(c) Long duct (L):

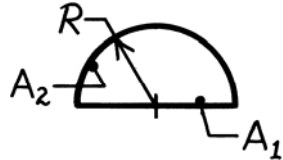

By inspection,  $F_{12} = 1.0$

By reciprocity,  $F_{21} = \frac{A_1}{A_2} F_{12} = \frac{2RL}{\pi RL} \times 1.0 = \frac{2}{\pi} = 0.637$  <

Summation rule,  $F_{22} = 1 - F_{21} = 1 - 0.64 = 0.363$ . <

(d) Long inclined plates (L):

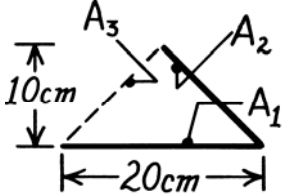

Summation rule,  $F_{11} + F_{12} + F_{13} = 1$

But  $F_{12} = F_{13}$  by symmetry, hence  $F_{12} = 0.50$  <

By reciprocity,  $F_{21} = \frac{A_1}{A_2} F_{12} = \frac{20L}{10(2)^{1/2} L} \times 0.5 = 0.707$ . <

(e) Sphere lying on infinite plane



Summation rule,  $F_{11} + F_{12} + F_{13} = 1$

But  $F_{12} = F_{13}$  by symmetry, hence  $F_{12} = 0.5$  <

By reciprocity,  $F_{21} = \frac{A_1}{A_2} F_{12} \rightarrow 0$  since  $A_2 \rightarrow \infty$ . <

Continued ...

**PROBLEM 13.1 (Cont.)**

(f) Hemisphere over a disc of diameter  $D/2$ ; find also  $F_{22}$  and  $F_{23}$ .

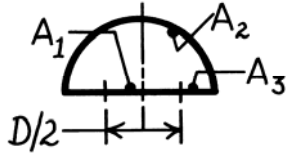

By inspection,  $F_{12} = 1.0$

Summation rule for surface  $A_3$  is written as

$$F_{31} + F_{32} + F_{33} = 1. \quad \text{Hence, } F_{32} = 1.0.$$

By reciprocity, 
$$F_{23} = \frac{A_3}{A_2} F_{32}$$

$$F_{23} = \left\{ \left[ \frac{\pi D^2}{4} - \frac{\pi (D/2)^2}{4} \right] / \frac{\pi D^2}{2} \right\} 1.0 = 0.375.$$

By reciprocity, 
$$F_{21} = \frac{A_1}{A_2} F_{12} = \left\{ \frac{\pi \left[ \frac{D}{2} \right]^2}{4} / \frac{\pi D^2}{2} \right\} \times 1.0 = 0.125.$$

Summation rule for  $A_2$ , 
$$F_{21} + F_{22} + F_{23} = 1 \quad \text{or}$$

$$F_{22} = 1 - F_{21} - F_{23} = 1 - 0.125 - 0.375 = 0.5.$$

Note that by inspection you can deduce  $F_{22} = 0.5$

(g) Long open channel (L):

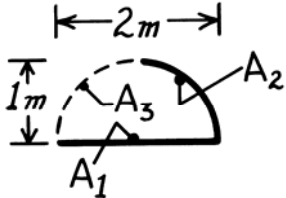

Summation rule for  $A_1$

$$F_{11} + F_{12} + F_{13} = 0$$

but  $F_{12} = F_{13}$  by symmetry, hence  $F_{12} = 0.50$ .

By reciprocity, 
$$F_{21} = \frac{A_1}{A_2} F_{12} = \frac{2 \times L}{(2\pi L) / 4 \times L} = \frac{4}{\pi} \times 0.50 = 0.637.$$

**COMMENTS:** (1) Note that the summation rule is applied to an enclosure. To complete the enclosure, it was necessary in several cases to define a third surface which was shown by dashed lines.

(2) Recognize that the solutions follow a systematic procedure; in many instances it is possible to deduce a shape factor by inspection.

### PROBLEM 13.2

**KNOWN:** Geometry of semi-circular, rectangular and V grooves.

**FIND:** (a) View factors of grooves with respect to surroundings, (b) View factor for sides of V groove, (c) View factor for sides of rectangular groove.

**SCHEMATIC:**

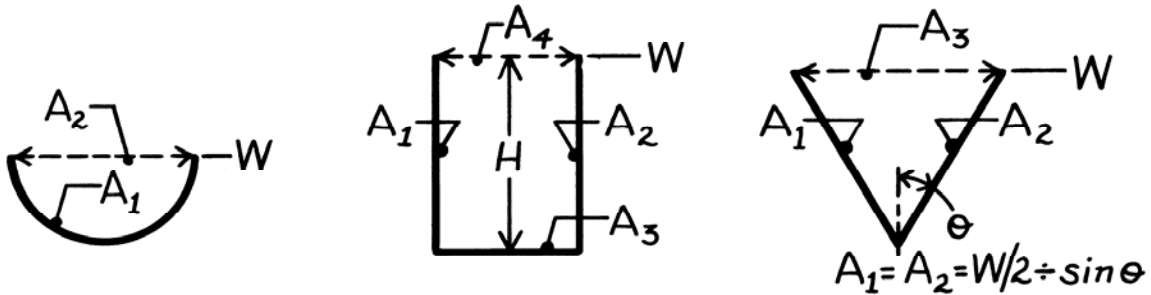

**ASSUMPTIONS:** (1) Diffuse surfaces, (2) Negligible end effects, “long grooves”.

**ANALYSIS:** (a) Consider a unit length of each groove and represent the surroundings by a hypothetical surface (dashed line).

*Semi-Circular Groove:*

$$F_{21} = 1; \quad F_{12} = \frac{A_2}{A_1} F_{21} = \frac{W}{(\pi W/2)} \times 1$$

$$F_{12} = 2/\pi. \quad <$$

*Rectangular Groove:*

$$F_{4(1,2,3)} = 1; \quad F_{(1,2,3)4} = \frac{A_4}{A_1 + A_2 + A_3} F_{4(1,2,3)} = \frac{W}{H + W + H} \times 1$$

$$F_{(1,2,3)4} = W/(W + 2H). \quad <$$

*V Groove:*

$$F_{3(1,2)} = 1; \quad F_{(1,2)3} = \frac{A_3}{A_1 + A_2} F_{3(1,2)} = \frac{W}{\frac{W/2}{\sin \theta} + \frac{W/2}{\sin \theta}}$$

$$F_{(1,2)3} = \sin \theta.$$

(b) From Eqs. 13.3 and 13.4,  $F_{12} = 1 - F_{13} = 1 - \frac{A_3}{A_1} F_{31}.$

From Symmetry,  $F_{31} = 1/2.$

Hence,  $F_{12} = 1 - \frac{W}{(W/2)/\sin \theta} \times \frac{1}{2}$  or  $F_{12} = 1 - \sin \theta. \quad <$

(c) From Fig. 13.4, with  $X/L = H/W = 2$  and  $Y/L \rightarrow \infty,$

$$F_{12} \approx 0.62. \quad <$$

**COMMENTS:** (1) Note that for the V groove,  $F_{13} = F_{23} = F_{(1,2)3} = \sin \theta,$  (2) In part (c), Fig. 13.4 could also be used with  $Y/L = 2$  and  $X/L = \infty.$  However, obtaining the limit of  $F_{ij}$  as  $X/L \rightarrow \infty$  from the figure is somewhat uncertain.

### PROBLEM 13.3

**KNOWN:** Two arrangements (a) circular disk and coaxial, ring shaped disk, and (b) circular disk and coaxial, right-circular cone.

**FIND:** Derive expressions for the view factor  $F_{12}$  for the arrangements (a) and (b) in terms of the areas  $A_1$  and  $A_2$ , and any appropriate hypothetical surface area, as well as the view factor for coaxial parallel disks (Table 13.2, Figure 13.5). For the disk-cone arrangement, sketch the variation of  $F_{12}$  with  $\theta$  for  $0 \leq \theta \leq \pi/2$ , and explain the key features.

**SCHEMATIC:**

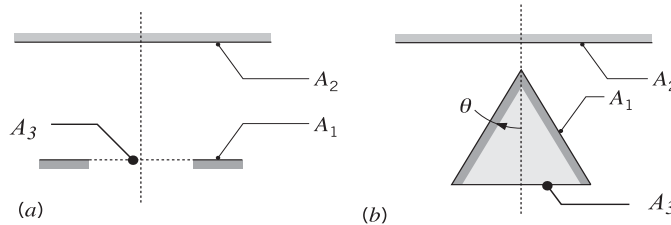

**ASSUMPTIONS:** Diffuse surfaces with uniform radiosities.

**ANALYSIS:** (a) Define the hypothetical surface  $A_3$ , a co-planar disk inside the ring of  $A_1$ . Using the additive view factor relation, Eq. 13.5,

$$A_{(1,3)} F_{(1,3)} = A_1 F_{12} + A_3 F_{32}$$

$$F_{12} = \frac{1}{A_1} \left[ A_{(1,3)} F_{(1,3)} - A_3 F_{32} \right] \quad <$$

where the parenthesis denote a composite surface. All the  $F_{ij}$  on the right-hand side can be evaluated using Fig. 13.5.

(b) Define the hypothetical surface  $A_3$ , the disk at the bottom of the cone. The radiant power leaving  $A_2$  that is intercepted by  $A_1$  can be expressed as

$$F_{21} = F_{23} \quad (1)$$

That is, the same power also intercepts the disk at the bottom of the cone,  $A_3$ . From reciprocity,

$$A_1 F_{12} = A_2 F_{21} \quad (2)$$

and using Eq. (1),

$$F_{12} = \frac{A_2}{A_1} F_{23} \quad <$$

The variation of  $F_{12}$  as a function of  $\theta$  is shown below for the disk-cone arrangement. In the limit when  $\theta \rightarrow \pi/2$ , the cone approaches a disk of area  $A_3$ . That is,

$$F_{12} (\theta \rightarrow \pi/2) = F_{13}$$

When  $\theta \rightarrow 0$ , the cone area  $A_2$  diminishes so that

$$F_{12} (\theta \rightarrow 0) = 0$$

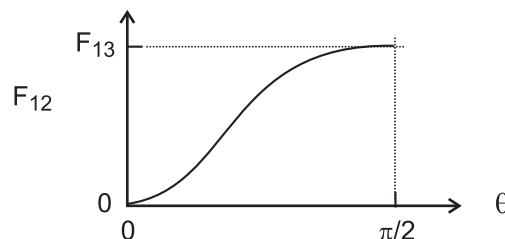

### PROBLEM 13.4

**KNOWN:** Right circular cone and right-circular cylinder of same diameter  $D$  and length  $L$  positioned coaxially a distance  $L_o$  from the circular disk  $A_1$ ; hypothetical area corresponding to the openings identified as  $A_3$ .

**FIND:** (a) Show that  $F_{21} = (A_1/A_2) F_{13}$  and  $F_{22} = 1 - (A_3/A_2)$ , where  $F_{13}$  is the view factor between two, coaxial parallel disks (Table 13.2), for both arrangements, (b) Calculate  $F_{21}$  and  $F_{22}$  for  $L = L_o = 50$  mm and  $D_1 = D_3 = 50$  mm; compare magnitudes and explain similarities and differences, and (c) Magnitudes of  $F_{21}$  and  $F_{22}$  as  $L$  increases and all other parameters remain the same; sketch and explain key features of their variation with  $L$ .

**SCHEMATIC:**

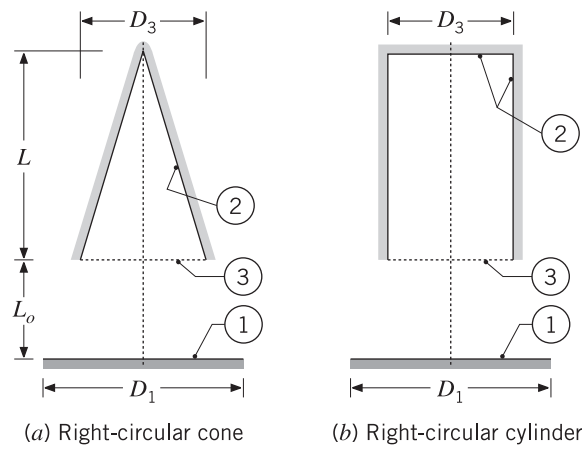

**ASSUMPTIONS:** (1) Diffuse surfaces with uniform radiosities, and (2) Inner base and lateral surfaces of the cylinder treated as a single surface,  $A_2$ .

**ANALYSIS:** (a) For both configurations,

$$F_{13} = F_{12} \tag{1}$$

since the radiant power leaving  $A_1$  that is intercepted by  $A_3$  is likewise intercepted by  $A_2$ . Applying reciprocity between  $A_1$  and  $A_2$ ,

$$A_1 F_{12} = A_2 F_{21} \tag{2}$$

Substituting from Eq. (1), into Eq. (2), solving for  $F_{21}$ , find

$$F_{21} = (A_1 / A_2) F_{12} = (A_1 / A_2) F_{13} \tag{3}$$

Treating the cone and cylinder as two-surface enclosures, the summation rule for  $A_2$  is

$$F_{22} + F_{23} = 1 \tag{3}$$

Apply reciprocity between  $A_2$  and  $A_3$ , solve Eq. (3) to find

$$F_{22} = 1 - F_{23} = 1 - (A_3 / A_2) F_{32}$$

and since  $F_{32} = 1$ , find

$$F_{22} = 1 - A_3 / A_2 \tag{3}$$

Continued ...

### PROBLEM 13.4 (Cont.)

(b) For the specified values of  $L$ ,  $L_o$ ,  $D_1$  and  $D_2$ , the view factors are calculated and tabulated below. Relations for the areas are:

$$\text{Disk-cone:} \quad A_1 = \pi D_1^2 / 4 \quad A_2 = \pi D_3 / 2 \left( L^2 + (D_3 / 2)^2 \right)^{1/2} \quad A_3 = \pi D_3^2 / 4$$

$$\text{Disk-cylinder:} \quad A_1 = \pi D_1^2 / 4 \quad A_2 = \pi D_3^2 / 4 + \pi D_3 L \quad A_3 = \pi D_3^2 / 4$$

The view factor  $F_{13}$  is evaluated from Table 13.2, coaxial parallel disks (Fig. 13.5); find  $F_{13} = 0.1716$ .

	$F_{21}$	$F_{22}$
<i>Disk-cone</i>	0.0767	0.553
<i>Disk-cylinder</i>	0.0343	0.800

It follows that  $F_{21}$  is greater for the disk-cone (a) than for the cylinder-cone (b). That is, for (a), surface  $A_2$  sees more of  $A_1$  and less of itself than for (b). Notice that  $F_{22}$  is greater for (b) than (a); this is a consequence of  $A_{2,b} > A_{2,a}$ .

(c) Using the foregoing equations in the IHT workspace, the variation of the view factors  $F_{21}$  and  $F_{22}$  with  $L$  were calculated and are graphed below.

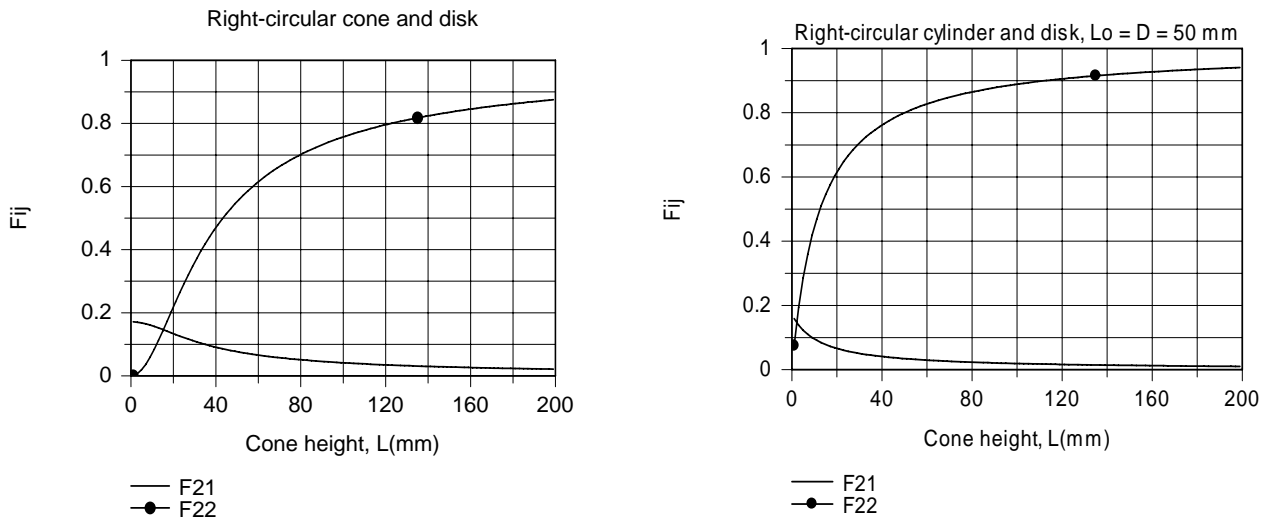

Note that for both configurations, when  $L = 0$ , find that  $F_{21} = F_{13} = 0.1716$ , the value obtained for coaxial parallel disks. As  $L$  increases, find that  $F_{22} \rightarrow 1$ ; that is, the interior of both the cone and cylinder see mostly each other. Notice that the changes in both  $F_{21}$  and  $F_{22}$  with increasing  $L$  are greater for the disk-cylinder;  $F_{21}$  decreases while  $F_{22}$  increases.

**COMMENTS:** From the results of part (b), why isn't the sum of  $F_{21}$  and  $F_{22}$  equal to unity?



### PROBLEM 13.5

**KNOWN:** Two parallel, coaxial, ring-shaped disks.

**FIND:** Show that the view factor  $F_{12}$  can be expressed as

$$F_{12} = \frac{1}{A_1} \left\{ A_{(1,3)} F_{(1,3)(2,4)} - A_3 F_{3(2,4)} - A_4 (F_{4(1,3)} - F_{43}) \right\}$$

where all the  $F_{ij}$  on the right-hand side of the equation can be evaluated from Figure 13.5 (see Table 13.2) for coaxial parallel disks.

**SCHEMATIC:**

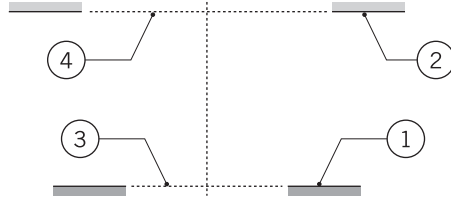

**ASSUMPTIONS:** Diffuse surfaces with uniform radiosities.

**ANALYSIS:** Using the additive rule, Eq. 13.5, where the parenthesis denote a composite surface,

$$F_{1(2,4)} = F_{12} + F_{14}$$

$$F_{12} = F_{1(2,4)} - F_{14} \quad (1)$$

*Relation for  $F_{1(2,4)}$ :* Using the additive rule

$$A_{(1,3)} F_{(1,3)(2,4)} = A_1 F_{1(2,4)} + A_3 F_{3(2,4)} \quad (2)$$

where the check mark denotes a  $F_{ij}$  that can be evaluated using Fig. 13.5 for coaxial parallel disks.

*Relation for  $F_{14}$ :* Apply reciprocity

$$A_1 F_{14} = A_4 F_{41} \quad (3)$$

and using the additive rule involving  $F_{41}$ ,

$$A_1 F_{14} = A_4 \left[ F_{4(1,3)} - F_{43} \right] \quad (4)$$

*Relation for  $F_{12}$ :* Substituting Eqs. (2) and (4) into Eq. (1),

$$F_{12} = \frac{1}{A_1} \left\{ A_{(1,3)} F_{(1,3)(2,4)} - A_3 F_{3(2,4)} - A_4 (F_{4(1,3)} - F_{43}) \right\} \quad <$$

**COMMENTS:** (1) The  $F_{ij}$  on the right-hand side can be evaluated using Fig. 13.5.

(2) To check the validity of the result, substitute numerical values and test the behavior at special limits. For example, as  $A_3, A_4 \rightarrow 0$ , the expression reduces to the identity  $F_{12} \equiv F_{12}$ .

### PROBLEM 13.6

**KNOWN:** Dimensions of four geometrical arrangements.

**FIND:** View factors using “crossed-strings” method; compare with appropriate graphs and analytical expressions.

**SCHEMATIC:**

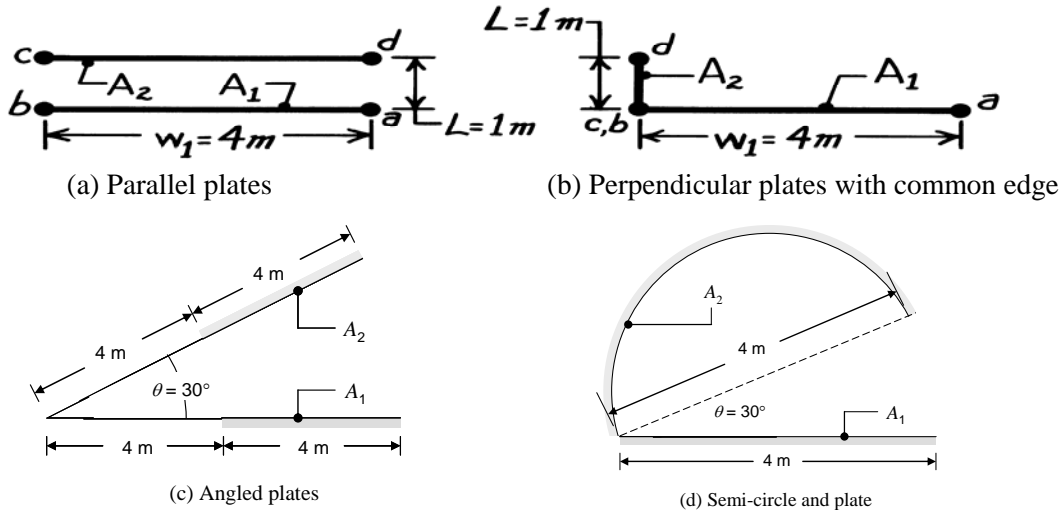

**ASSUMPTIONS:** Plates infinite in extent in direction normal to page.

**ANALYSIS:** The crossed-strings method is applicable to surfaces of infinite extent in one direction having an unobstructed view of one another.

$$F_{12} = (1/2w_1)[(ac + bd) - (ad + bc)].$$

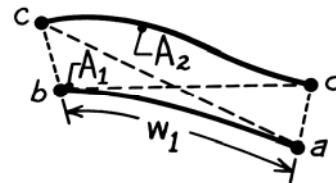

(a) *Parallel plates:* From the schematic, the edge and diagonal distances are

$$ac = bd = (w_1^2 + L^2)^{1/2} \quad bc = ad = L.$$

With  $w_1$  as the width of the plate, find

$$F_{12} = \frac{1}{2w_1} \left[ 2(w_1^2 + L^2)^{1/2} - 2(L) \right] = \frac{1}{2 \times 4 \text{ m}} \left[ 2(4^2 + 1^2)^{1/2} \text{ m} - 2(1 \text{ m}) \right] = 0.781. \quad <$$

Using Fig. 13.4 with  $X/L = 4/1 = 4$  and  $Y/L = \infty$ , find  $F_{12} \approx 0.80$ . Also, using the first relation of Table 13.1,

$$F_{ij} = \left\{ \left[ (W_i + W_j)^2 + 4 \right]^{1/2} - \left[ (W_i - W_j)^2 + 4 \right]^{1/2} \right\} / 2W_i$$

where  $w_i = w_j = w_1$  and  $W = w/L = 4/1 = 4$ , find

$$F_{12} = \left\{ \left[ (4+4)^2 + 4 \right]^{1/2} - \left[ (4-4)^2 + 4 \right]^{1/2} \right\} / 2 \times 4 = 0.781.$$

Continued...

### PROBLEM 13.6 (Cont.)

(b) *Perpendicular plates* with a common edge: From the schematic, the edge and diagonal distances are

$$ac = w_1 \quad bd = L \quad ad = \left( w_1^2 + L^2 \right)^{1/2} \quad bc = 0.$$

With  $w_1$  as the width of the horizontal plates, find

$$F_{12} = (1/2w_1) \left[ 2(w_1 + L) - \left( \left( w_1^2 + L^2 \right)^{1/2} + 0 \right) \right]$$

$$F_{12} = (1/2 \times 4 \text{ m}) \left[ (4 + 1) \text{ m} - \left( \left( 4^2 + 1^2 \right)^{1/2} \text{ m} + 0 \right) \right] = 0.110. \quad <$$

From the third relation of Table 13.1, with  $w_i = w_1 = 4 \text{ m}$  and  $w_j = L = 1 \text{ m}$ , find

$$F_{ij} = \left\{ 1 + \left( w_j / w_i \right) - \left[ 1 + \left( w_j / w_i \right)^2 \right]^{1/2} \right\} / 2$$

$$F_{12} = \left\{ 1 + (1/4) - \left[ 1 + (1/4)^2 \right]^{1/2} \right\} / 2 = 0.110.$$

(c) *Plates at an angle to one another.* From the schematic below, the edge and diagonal distances can be calculated as follows:

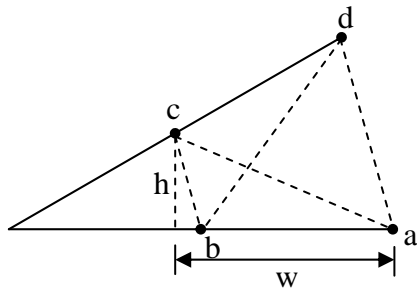

$$h = 4 \sin 30^\circ, \quad w = 8 - 4 \cos 30^\circ, \quad ac = \sqrt{h^2 + w^2} = 4.96 \text{ m}$$

$$\text{By symmetry, } bd = ac = 4.96 \text{ m}$$

$$bc = 2(4 \sin 15^\circ) = 2.07 \text{ m}$$

$$ad = 2(8 \sin 15^\circ) = 4.14 \text{ m}$$

We find

$$F_{12} = (1/8) \left[ (4.96 + 4.96) - (4.14 + 2.07) \right] = 0.463. \quad <$$

The same result can be found using the second and fourth view factors in Table 13.1, along with Equations 13.5 and 13.6.

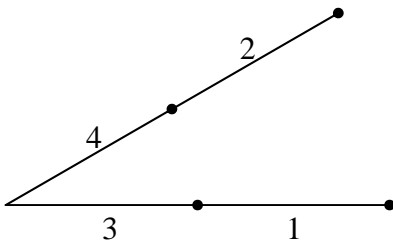

From Eq. 13.5 with  $i = 3$  and  $j$  representing the combination (24),

$$F_{3-(24)} = F_{32} + F_{34}.$$

Then from Table 13.1 4<sup>th</sup> entry,

$$F_{3-(24)} = (w_3 + w_{24} - bd) / 2w_3 = (4 + 8 - 4.96) / 8 = 0.880$$

Continued...

### PROBLEM 13.6 (Cont.)

From Table 13.1, 2<sup>nd</sup> entry,  $F_{34} = 1 - \sin(30^\circ/2) = 0.741$ . Thus  $F_{32} = 0.880 - 0.741 = 0.139$ . Using Eq. 13.5 again, with  $i$  representing the combination of (13) and  $j$  representing the combination (24),

$$F_{(13)-(24)} = F_{(13)-2} + F_{(13)-4}$$

$F_{(13)-4}$  can be found using reciprocity, namely  $F_{(13)-4} = A_4 F_{4-(13)} / A_{13} = A_4 F_{3-(24)} / A_{13} = 0.5 F_{3-(24)} = 0.440$ . Then from Table 13.1, 2<sup>nd</sup> entry, it can be seen that  $F_{(13)-(24)} = F_{34} = 0.741$ . Thus,

$$F_{(13)-2} = F_{(13)-(24)} - F_{(13)-4} = 0.301$$

Finally, from Eq. 13.6, with  $i = 2$  and  $j$  representing the combination (13),

$$A_{13} F_{(13)-2} = A_1 F_{12} + A_3 F_{32}$$

Therefore,

$$F_{12} = (A_{13} F_{(13)-2} - A_3 F_{32}) / A_1 = (8 \times 0.301 - 4 \times 0.139) / 4 = 0.463.$$

(d) *Semi-circle and plate at angle to each other.*

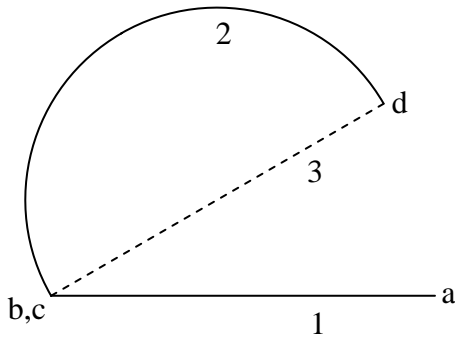

The edge and diagonal distances are

$$ac = 8 \text{ m}, bc = 0 \text{ m}, ad = 2(8 \sin 15^\circ) = 4.14 \text{ m}, bd = 8 \text{ m}$$

We find

$$F_{12} = (1/16)[(8+8) - (4.14+0)] = 0.741.$$

<

The same result can be found using view factor relations in Table 13.1. Since radiation traveling from 1 to 2 must pass through 3,  $F_{12} = F_{13}$ . From Table 13.1, 2<sup>nd</sup> entry,

$$F_{12} = 1 - \sin(30^\circ/2) = 0.741$$

**COMMENTS:** (1) Hottel's method can be a significant time-saver. (2) The application of Hottel's method to cases where the view is obstructed between the two surfaces is discussed in Siegel, R., J.R. Howell, and M.P. Menguc, *Thermal Radiation Heat Transfer*, 5<sup>th</sup> ed., CRC Press, Taylor & Francis Group, New York, 2010 and in Modest, M.F., *Radiative Heat Transfer*, 2<sup>nd</sup> ed., Academic Press, San Diego, 2003.

### PROBLEM 13.7

**KNOWN:** Right-circular cylinder of diameter  $D$ , length  $L$  and the areas  $A_1$ ,  $A_2$ , and  $A_3$  representing the base, inner lateral and top surfaces, respectively.

**FIND:** (a) Show that the view factor between the base of the cylinder and the inner lateral surface has the form

$$F_{12} = 2 H \left[ \left(1 + H^2\right)^{1/2} - H \right]$$

where  $H = L/D$ , and (b) Show that the view factor for the inner lateral surface to itself has the form

$$F_{22} = 1 + H - \left(1 + H^2\right)^{1/2}$$

**SCHEMATIC:**

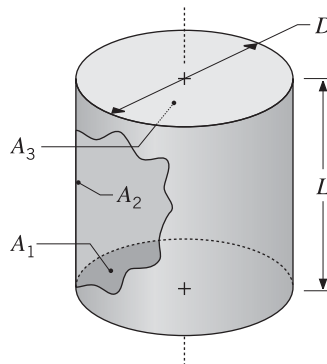

**ASSUMPTIONS:** Diffuse surfaces with uniform radiosities.

**ANALYSIS:** (a) *Relation for  $F_{12}$ , base-to-inner lateral surface.* Apply the summation rule to  $A_1$ , noting that  $F_{11} = 0$

$$F_{11} + F_{12} + F_{13} = 1$$

$$F_{12} = 1 - F_{13} \tag{1}$$

From Table 13.2, Fig. 13.5, with  $i = 1, j = 3$ ,

$$F_{13} = \frac{1}{2} \left\{ S - \left[ S^2 - 4(D_3 / D_1)^2 \right]^{1/2} \right\} \tag{2}$$

$$S = 1 + \frac{1 + R_3^2}{R_1^2} = \frac{1}{R^2} + 2 = 4 H^2 + 2 \tag{3}$$

where  $R_1 = R_3 = R = D/2L$  and  $H = L/D$ . Combining Eqs. (2) and (3) with Eq. (1), find after some manipulation

Continued ...

**PROBLEM 13.7 (Cont.)**

$$F_{12} = 1 - \frac{1}{2} \left\{ 4H^2 + 2 - \left[ (4H^2 + 2)^2 - 4 \right]^{1/2} \right\}$$
$$F_{12} = 2H \left[ (1 + H^2)^{1/2} - H \right] \quad (4)$$

(b) *Relation for  $F_{22}$ , inner lateral surface.* Apply summation rule on  $A_2$ , recognizing that  $F_{23} = F_{21}$ ,

$$F_{21} + F_{22} + F_{23} = 1 \quad F_{22} = 1 - 2F_{21} \quad (5)$$

Apply reciprocity between  $A_1$  and  $A_2$ ,

$$F_{21} = (A_1 / A_2) F_{12} \quad (6)$$

and substituting into Eq. (5), and using area expressions

$$F_{22} = 1 - 2 \frac{A_1}{A_2} F_{12} = 1 - 2 \frac{D}{4L} F_{12} = 1 - \frac{1}{2H} F_{12} \quad (7)$$

where  $A_1 = \pi D^2/4$  and  $A_2 = \pi DL$ .

Substituting from Eq. (4) for  $F_{12}$ , find

$$F_{22} = 1 - \frac{1}{2H} 2H \left[ (1 + H^2)^{1/2} - H \right] = 1 + H - (1 + H^2)^{1/2} \quad <$$

### PROBLEM 13.8

**KNOWN:** Arrangement of plane parallel rectangles.

**FIND:** Show that the view factor between  $A_1$  and  $A_2$  can be expressed as

$$F_{12} = \frac{1}{2 A_1} \left[ A_{(1,4)} F_{(1,4)(2,3)} - A_1 F_{13} - A_4 F_{42} \right]$$

where all  $F_{ij}$  on the right-hand side of the equation can be evaluated from Fig. 13.4 (see Table 13.2) for aligned parallel rectangles.

**SCHEMATIC:**

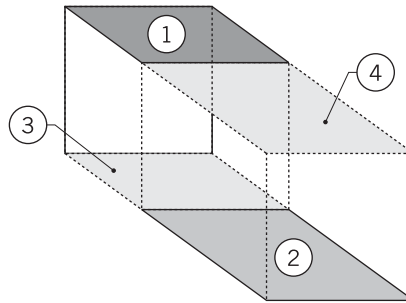

**ASSUMPTIONS:** Diffuse surfaces with uniform radiosity.

**ANALYSIS:** Using the additive rule where the parenthesis denote a composite surface,

$$A_{(1,4)} F_{(1,4)(2,3)}^* = A_1 F_{13}^* + A_1 F_{12} + A_4 F_{43} + A_4 F_{42}^* \quad (1)$$

where the asterisk (\*) denotes that the  $F_{ij}$  can be evaluated using the relation of Figure 13.4. Now, find suitable relation for  $F_{43}$ . By symmetry,

$$F_{43} = F_{21} \quad (2)$$

and from reciprocity between  $A_1$  and  $A_2$ ,

$$F_{21} = \frac{A_1}{A_2} F_{12} \quad (3)$$

Multiply Eq. (2) by  $A_4$  and substitute Eq. (3), with  $A_4 = A_2$ ,

$$A_4 F_{43} = A_4 F_{21} = A_4 \frac{A_1}{A_2} F_{12} = A_1 F_{12} \quad (4)$$

Substituting for  $A_4 F_{43}$  from Eq. (4) into Eq. (1), and rearranging,

$$F_{12} = \frac{1}{2 A_1} \left[ A_{(1,4)} F_{(1,4)(2,3)}^* - A_1 F_{13}^* - A_4 F_{42}^* \right] \quad <$$

### PROBLEM 13.9

**KNOWN:** Two perpendicular rectangles not having a common edge.

**FIND:** (a) Shape factor,  $F_{12}$ , and (b) Compute and plot  $F_{12}$  as a function of  $Z_b$  for  $0.05 \leq Z_b \leq 0.4$  m; compare results with the view factor obtained from the two-dimensional relation for perpendicular plates with a common edge, Table 13.1.

**SCHEMATIC:**

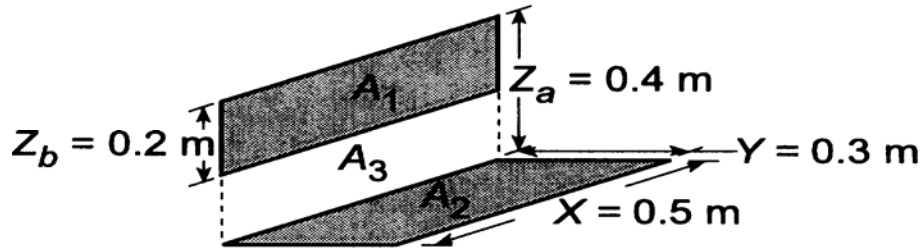

**ASSUMPTIONS:** (1) All surfaces are diffuse, (2) Plane formed by  $A_1 + A_3$  is perpendicular to plane of  $A_2$ .

**ANALYSIS:** (a) Introducing the hypothetical surface  $A_3$ , we can write

$$F_{2(3,1)} = F_{23} + F_{21} \quad (1)$$

Using Fig. 13.6, applicable to perpendicular rectangles with a common edge, find

$$F_{23} = 0.19: \quad \text{with } Y = 0.3, \quad X = 0.5, \quad Z = Z_a - Z_b = 0.2, \quad \text{and } \frac{Y}{X} = \frac{0.3}{0.5} = 0.6, \quad \frac{Z}{X} = \frac{0.2}{0.5} = 0.4$$

$$F_{2(3,1)} = 0.25: \quad \text{with } Y = 0.3, \quad X = 0.5, \quad Z_a = 0.4, \quad \text{and } \frac{Y}{X} = \frac{0.3}{0.5} = 0.6, \quad \frac{Z}{X} = \frac{0.4}{0.5} = 0.8$$

Hence from Eq. (1)

$$F_{21} = F_{2(3,1)} - F_{23} = 0.25 - 0.19 = 0.06$$

By reciprocity,

$$F_{12} = \frac{A_2}{A_1} F_{21} = \frac{0.5 \times 0.3 \text{ m}^2}{0.5 \times 0.2 \text{ m}^2} \times 0.06 = 0.09 \quad (2) <$$

(b) Using the *IHT Tool – View Factors for Perpendicular Rectangles with a Common Edge* and Eqs. (1,2) above,  $F_{12}$  was computed as a function of  $Z_b$ . Also shown on the plot below is the view factor  $F_{(3,1)2}$  for the limiting case  $Z_b \rightarrow Z_a$ .

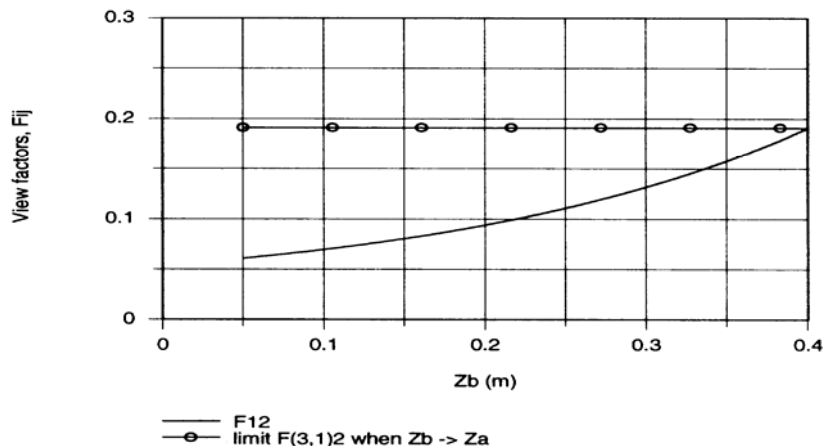



### PROBLEM 13.10

**KNOWN:** Arrangement of perpendicular surfaces without a common edge.

**FIND:** (a) A relation for the view factor  $F_{14}$  and (b) The value of  $F_{14}$  for prescribed dimensions.

**SCHEMATIC:**

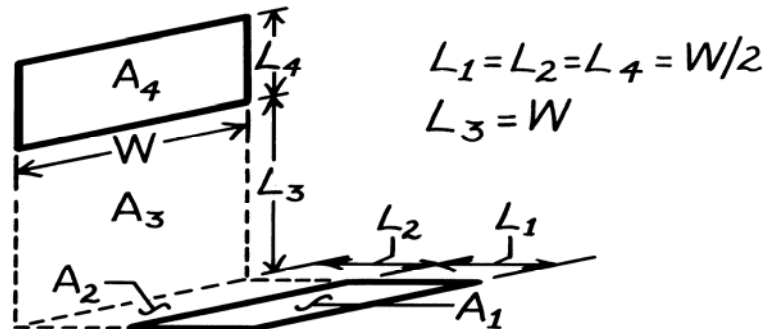

**ASSUMPTIONS:** (1) Diffuse surfaces.

**ANALYSIS:** (a) To determine  $F_{14}$ , it is convenient to define the hypothetical surfaces  $A_2$  and  $A_3$ . From Eq. 13.6,

$$(A_1 + A_2)F_{(1,2)(3,4)} = A_1 F_{1(3,4)} + A_2 F_{2(3,4)}$$

where  $F_{(1,2)(3,4)}$  and  $F_{2(3,4)}$  may be obtained from Fig. 13.6. Substituting for  $A_1 F_{1(3,4)}$  from Eq. 13.5 and combining expressions, find

$$A_1 F_{1(3,4)} = A_1 F_{13} + A_1 F_{14}$$

$$F_{14} = \frac{1}{A_1} \left[ (A_1 + A_2)F_{(1,2)(3,4)} - A_1 F_{13} - A_2 F_{2(3,4)} \right].$$

Substituting for  $A_1 F_{13}$  from Eq. 13.6, which may be expressed as

$$(A_1 + A_2)F_{(1,2)3} = A_1 F_{13} + A_2 F_{23}.$$

The desired relation is then

$$F_{14} = \frac{1}{A_1} \left[ (A_1 + A_2)F_{(1,2)(3,4)} + A_2 F_{23} - (A_1 + A_2)F_{(1,2)3} - A_2 F_{2(3,4)} \right]. \quad <$$

(b) For the prescribed dimensions and using Fig. 13.6, find these view factors:

*Surfaces (1,2)(3,4)*       $(Y/X) = \frac{L_1 + L_2}{W} = 1, \quad (Z/X) = \frac{L_3 + L_4}{W} = 1.45, \quad F_{(1,2)(3,4)} = 0.22$

*Surfaces 23*       $(Y/X) = \frac{L_2}{W} = 0.5, \quad (Z/X) = \frac{L_3}{W} = 1, \quad F_{23} = 0.28$

*Surfaces (1,2)3*       $(Y/X) = \frac{L_1 + L_2}{W} = 1, \quad (Z/X) = \frac{L_3}{W} = 1, \quad F_{(1,2)3} = 0.20$

*Surfaces 2(3,4)*       $(Y/X) = \frac{L_2}{W} = 0.5, \quad (Z/X) = \frac{L_3 + L_4}{W} = 1.5, \quad F_{2(3,4)} = 0.31$

Using the relation above, find

$$F_{14} = \frac{1}{(WL_1)} \left[ (WL_1 + WL_2)0.22 + (WL_2)0.28 - (WL_1 + WL_2)0.20 - (WL_2)0.31 \right]$$

$$F_{14} = [2(0.22) + 1(0.28) - 2(0.20) - 1(0.31)] = 0.01. \quad <$$

### PROBLEM 13.11

**KNOWN:** Arrangements of rectangles.

**FIND:** The shape factors,  $F_{12}$ .

**SCHEMATIC:**

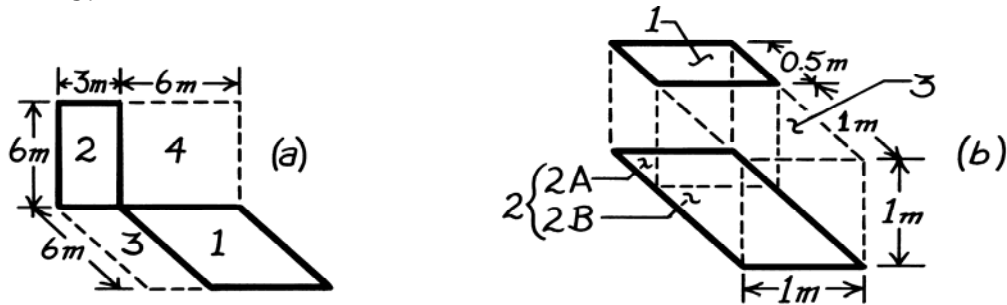

**ASSUMPTIONS:** (1) Diffuse surface behavior.

**ANALYSIS:** (a) Define the hypothetical surfaces shown in the sketch as  $A_3$  and  $A_4$ . From the additive view factor rule, Eq. 13.6, we can write

$$A_{(1,3)} \sqrt{F_{(1,3)}(2,4)} = A_1 F_{12} + A_1 F_{14} + A_3 F_{32} + A_3 F_{34} \quad (1)$$

Note carefully which factors can be evaluated from Fig. 13.6 for perpendicular rectangles with a common edge. (See  $\surd$ ). It follows from symmetry that

$$A_1 F_{12} = A_4 F_{43}. \quad (2)$$

Using reciprocity,

$$A_4 F_{43} = A_3 F_{34}, \quad \text{then} \quad A_1 F_{12} = A_3 F_{34}. \quad (3)$$

Solving Eq. (1) for  $F_{12}$  and substituting Eq. (3) for  $A_3 F_{34}$ , find that

$$F_{12} = \frac{1}{2A_1} \left[ A_{(1,3)} F_{(1,3)}(2,4) - A_1 F_{14} - A_3 F_{32} \right]. \quad (4)$$

Evaluate the view factors from Fig. 13.6:

$F_{ij}$	Y/X	Z/X	$F_{ij}$
(1,3) (2,4)	$\frac{6}{9} = 0.67$	$\frac{6}{9} = 0.67$	0.23
14	$\frac{6}{6} = 1$	$\frac{6}{6} = 1$	0.20
32	$\frac{6}{3} = 2$	$\frac{6}{3} = 2$	0.14

Substituting numerical values into Eq. (4) yields

$$F_{12} = \frac{1}{2 \times (6 \times 6) \text{ m}^2} \left[ (6 \times 9) \text{ m}^2 \times 0.23 - (6 \times 6) \text{ m}^2 \times 0.20 - (6 \times 3) \text{ m}^2 \times 0.14 \right]$$

$$F_{12} = 0.038.$$

<

Continued ...

**PROBLEM 13.11 (Cont.)**

(b) Define the hypothetical surface  $A_3$  and divide  $A_2$  into two sections,  $A_{2A}$  and  $A_{2B}$ . From the additive view factor rule, Eq. 13.6, we can write

$$A_{1,3} F_{(1,3)2} = A_1 F_{12} + A_3 F_{3(2A)} + A_3 F_{3(2B)}. \quad (5)$$

Note that the view factors checked can be evaluated from Fig. 13.4 for aligned, parallel rectangles. To evaluate  $F_{3(2A)}$ , we first recognize a relationship involving  $F_{(2A)1}$  will eventually be required. Using the additive rule again,

$$A_{2A} F_{(2A)(1,3)} = A_{2A} F_{(2A)1} + A_{2A} F_{(2A)3}. \quad (6)$$

Note that from symmetry considerations,

$$A_{2A} F_{(2A)(1,3)} = A_1 F_{12} \quad (7)$$

and using reciprocity, Eq. 13.3, note that

$$A_{2A} F_{2A3} = A_3 F_{3(2A)}. \quad (8)$$

Substituting for  $A_3 F_{3(2A)}$  from Eq. (8), Eq. (5) becomes

$$A_{(1,3)} F_{(1,3)2} = A_1 F_{12} + A_{2A} F_{(2A)3} + A_3 F_{3(2B)}.$$

Substituting for  $A_{2A} F_{(2A)3}$  from Eq. (6) using also Eq. (7) for  $A_{2A} F_{(2A)(1,3)}$  find that

$$A_{(1,3)} F_{(1,3)2} = A_1 F_{12} + \left( A_1 F_{12} - A_{2A} F_{(2A)1} \right) + A_3 F_{3(2B)} \quad (9)$$

and solving for  $F_{12}$ , noting that  $A_1 = A_{2A}$  and  $A_{(1,3)} = A_2$

$$F_{12} = \frac{1}{2A_1} \left[ A_2 F_{(1,3)2} + A_{2A} F_{(2A)1} - A_3 F_{3(2B)} \right]. \quad (10)$$

Evaluate the view factors from Fig. 13.4:

$F_{ij}$	X/L	Y/L	$F_{ij}$
(1,3) 2	$\frac{1}{1} = 1$	$\frac{1.5}{1} = 1.5$	0.25
(2A)1	$\frac{1}{1} = 1$	$\frac{0.5}{1} = 0.5$	0.11
3(2B)	$\frac{1}{1} = 1$	$\frac{1}{1} = 1$	0.20

Substituting numerical values into Eq. (10) yields

$$F_{12} = \frac{1}{2(0.5 \times 1) \text{m}^2} \left[ (1.5 \times 1.0) \text{m}^2 \times 0.25 + (0.5 \times 1) \text{m}^2 \times 0.11 - (1 \times 1) \text{m}^2 \times 0.20 \right]$$

$$F_{12} = 0.23.$$

<

## PROBLEM 13.12

**KNOWN:** Parallel plate geometry.

**FIND:** (a) The view factor  $F_{12}$  using the results of Figure 13.4, (b)  $F_{12}$  using the first case of Table 13.1, (c)  $F_{12}$  using Hottel's crossed-string method, (d)  $F_{12}$  using the second case of Table 13.1, (e)  $F_{12}$  for  $w = L = 2$  m using Figure 13.4.

**SCHEMATIC:**

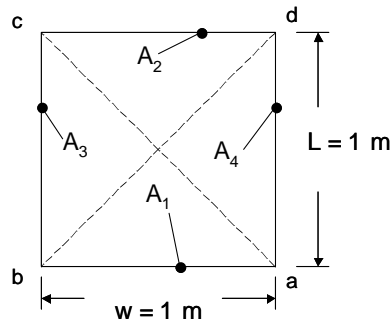

**ASSUMPTIONS:** (a) Two-dimensional system, (b) Diffuse, gray surfaces.

**ANALYSIS:** (a) Using Figure 13.4,  $X/L = 1\text{m}/1\text{m} = 1$ ,  $Y/L \rightarrow \infty$ ,  $F_{12} = 0.41$  <

(b) For case 1 of Table 13.1,  $W_1 = W_2 = 1\text{m}/1\text{m} = 1$  and

$$F_{12} = \frac{\left[2^2 + 4\right]^{1/2} - 4^{1/2}}{2} = 0.414 \quad <$$

(c) From Problem 13.6,

$$F_{12} = \frac{1}{2 \times 1 \text{ m}} \left[ 2 \times \frac{1 \text{ m}}{\cos(45^\circ)} - 2 \text{ m} \right] = 0.414 \quad <$$

(d) For case 2 of Table 13.1,  $w = 1\text{m}$ ,  $\alpha = 90^\circ$ ,  $F_{13} = 1 - \sin(45^\circ) = 0.293$ . By symmetry,  $F_{14} = 0.293$  and by the summation rule,

$$F_{12} = 1 - F_{13} - F_{14} = 1 - 2 \times 0.293 = 0.414 \quad <$$

(e) Using Figure 13.4,  $X/L = 2\text{m}/2\text{m} = 1$ ,  $Y/L \rightarrow \infty$ ,  $F_{12} = 0.41$  <

**COMMENTS:** For most radiation heat transfer problems involving enclosures composed of diffuse gray surfaces, there are many alternative approaches that may be used to determine the appropriate view factors. It is highly unlikely that the view factors will be evaluated the same way by different individuals when solving a radiation heat transfer problem.

### PROBLEM 13.13

**KNOWN:** Parallel plates of infinite extent (1,2) having aligned opposite edges.

**FIND:** View factor  $F_{12}$  by using (a) appropriate view factor relations and results for opposing parallel plates and (b) Hottel's string method described in Problem 13.6.

**SCHEMATIC:**

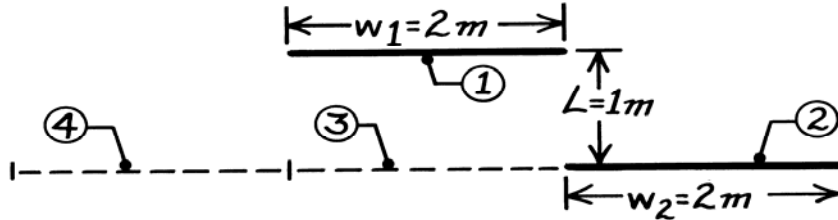

**ASSUMPTIONS:** (1) Parallel planes of infinite extent normal to page and (2) Diffuse surfaces with uniform radiosity.

**ANALYSIS:** From symmetry consideration ( $F_{12} = F_{14}$ ) and Eq. 13.5, it follows that

$$F_{12} = (1/2) [F_{1(2,3,4)} - F_{13}]$$

where  $A_3$  and  $A_4$  have been defined for convenience in the analysis. Each of these view factors can be evaluated by the first relation of Table 13.1 for parallel plates with midlines connected perpendicularly.

$$F_{13}: \quad W_1 = w_1 / L = 2$$

$$W_2 = w_2 / L = 2$$

$$F_{13} = \frac{\left[ (W_1 + W_2)^2 + 4 \right]^{1/2} - \left[ (W_2 - W_1)^2 + 4 \right]^{1/2}}{2W_1} = \frac{\left[ (2+2)^2 + 4 \right]^{1/2} - \left[ (2-2)^2 + 4 \right]^{1/2}}{2 \times 2} = 0.618$$

$$F_{1(2,3,4)}: \quad W_1 = w_1 / L = 2$$

$$W_{(2,3,4)} = 3w_2 / L = 6$$

$$F_{1(2,3,4)} = \frac{\left[ (2+6)^2 + 4 \right]^{1/2} - \left[ (6-2)^2 + 4 \right]^{1/2}}{2 \times 2} = 0.944.$$

Hence, find  $F_{12} = (1/2) [0.944 - 0.618] = 0.163.$

(b) Using Hottel's string method,

$$F_{12} = (1/2w_1) [(ac + bd) - (ad + bc)]$$

$$ac = (1 + 4^2)^{1/2} = 4.123$$

$$bd = 1$$

$$ad = (1^2 + 2^2)^{1/2} = 2.236$$

$$bc = ad = 2.236$$

and substituting numerical values find

$$F_{12} = (1/2 \times 2) [(4.123 + 1) - (2.236 + 2.236)] = 0.163.$$

**COMMENTS:** Remember that Hottel's string method is applicable only to surfaces that are of infinite extent in one direction and have unobstructed views of one another.

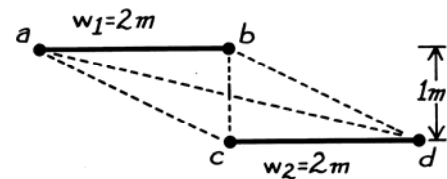

### PROBLEM 13.14

**KNOWN:** Two small diffuse surfaces,  $A_1$  and  $A_2$ , on the inside of a spherical enclosure of radius  $R$ .

**FIND:** Expression for the view factor  $F_{12}$  in terms of  $A_2$  and  $R$  by two methods: (a) Beginning with the expression  $F_{ij} = q_{ij}/A_i J_i$  and (b) Using the view factor integral, Eq. 13.1.

**SCHEMATIC:**

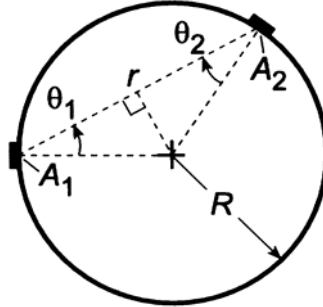

**ASSUMPTIONS:** (1) Surfaces  $A_1$  and  $A_2$  are diffuse and (2)  $A_1$  and  $A_2 \ll R^2$ .

**ANALYSIS:** (a) The view factor is defined as the fraction of radiation leaving  $A_i$  which is intercepted by surface  $j$  and, from Section 13.1.1, can be expressed as

$$F_{ij} = \frac{q_{ij}}{A_i J_i} \quad (1)$$

From Eq. 12.11, the radiation leaving intercepted by  $A_1$  and  $A_2$  on the spherical surface is

$$q_{1 \rightarrow 2} = (J_1 / \pi) \cdot A_1 \cos \theta_1 \cdot \omega_{2-1} \quad (2)$$

where the solid angle  $A_2$  subtends with respect to  $A_1$  is

$$\omega_{2-1} = \frac{A_{2,n}}{r^2} = \frac{A_2 \cos \theta_2}{r^2} \quad (3)$$

From the schematic above,

$$\cos \theta_1 = \cos \theta_2 \quad r = 2R \cos \theta_1 \quad (4,5)$$

Hence, the view factor is

$$F_{ij} = \frac{(J_1 / \pi) A_1 \cos \theta_1 \cdot A_2 \cos \theta_2 / 4R^2 \cos \theta_1}{A_1 J_1} = \frac{A_2}{4\pi R^2} \quad <$$

(b) The view factor integral, Eq. 13.1, for the small areas  $A_1$  and  $A_2$  is

$$F_{12} = \frac{1}{A_1} \int_{A_1} \int_{A_2} \frac{\cos \theta_1 \cos \theta_2}{\pi r^2} dA_1 dA_2 = \frac{\cos \theta_1 \cos \theta_2 A_2}{\pi r^2}$$

and from Eqs. (4,5) above,

$$F_{12} = \frac{A_2}{4\pi R^2} \quad <$$

**COMMENTS:** Recognize the importance of the second assumption. We require that  $A_1, A_2 \ll R^2$  so that the areas can be considered as of differential extent,  $A_1 = dA_1$ , and  $A_2 = dA_2$ . It may be shown, however, that due to the unique geometry of a sphere,  $F_{12} = A_2/(4\pi R^2)$  even when the areas are not small. See M.F. Modest, Radiation Heat Transfer, 2nd edition, Academic Press, San Diego, 2003.

### PROBLEM 13.15

**KNOWN:** Disk  $A_1$ , located coaxially, but tilted  $30^\circ$  of the normal, from the diffuse-gray, ring-shaped disk  $A_2$ . Surroundings at 400 K.

**FIND:** Irradiation on  $A_1$ ,  $G_1$ , due to the radiation from  $A_2$ .

**SCHEMATIC:**

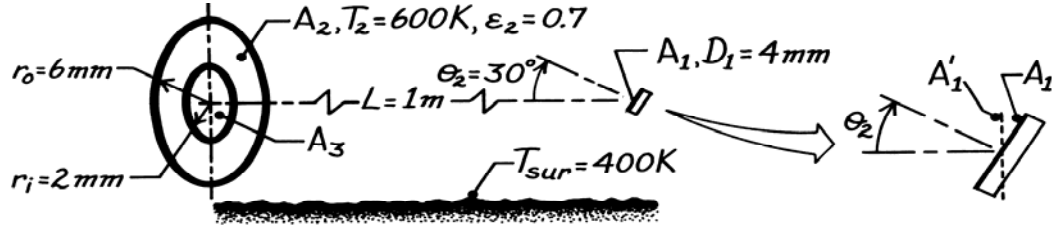

**ASSUMPTIONS:** (1)  $A_2$  is diffuse-gray surface, (2) Uniform radiosity over  $A_2$ , (3) The surroundings are large with respect to  $A_1$  and  $A_2$ .

**ANALYSIS:** The irradiation on  $A_1$  is

$$G_1 = q_{21} / A_1 = (F_{21} \cdot J_2 A_2) / A_1 \quad (1)$$

where  $J_2$  is the radiosity from  $A_2$  evaluated as

$$J_2 = \epsilon_2 E_{b,2} + \rho_2 G_2 = \epsilon_2 \sigma T_2^4 + (1 - \epsilon_2) \sigma T_{sur}^4$$

$$J_2 = 0.7 \times 5.67 \times 10^{-8} \text{ W/m}^2 \cdot \text{K}^4 (600 \text{ K})^4 + (1 - 0.7) 5.67 \times 10^{-8} \text{ W/m}^2 \cdot \text{K}^4 (400 \text{ K})^4$$

$$J_2 = 5144 + 436 = 5580 \text{ W/m}^2. \quad (2)$$

Using the view factor relation of Eq. 13.8, evaluate view factors between  $A_1'$ , the normal projection of  $A_1$ , and  $A_3$  as

$$F_{1'3} = \frac{D_1^2}{D_1^2 + 4L^2} = \frac{(0.004 \text{ m})^2}{(0.004 \text{ m})^2 + 4(1 \text{ m})^2} = 4.00 \times 10^{-6}$$

and between  $A_1'$  and  $(A_2 + A_3)$  as

$$F_{1'(23)} = \frac{D_o^2}{D_o^2 + 4L^2} = \frac{(0.012)^2}{(0.012)^2 + 4(1 \text{ m})^2} = 3.60 \times 10^{-5}$$

giving  $F_{1'2} = F_{1'(23)} - F_{1'3} = 3.60 \times 10^{-5} - 4.00 \times 10^{-6} = 3.20 \times 10^{-5}$ .

From the reciprocity relation it follows that

$$F_{21'} = A_1' F_{1'2} / A_2 = (A_1 \cos \theta_1 / A_2) F_{1'2} = 3.20 \times 10^{-5} \cos \theta_1 (A_1 / A_2). \quad (3)$$

By inspection we note that all the radiation striking  $A_1'$  will also intercept  $A_1$ ; that is

$$F_{21} = F_{21'}. \quad (4)$$

Hence, substituting for Eqs. (3) and (4) for  $F_{21}$  into Eq. (1), find

$$G_1 = \left( 3.20 \times 10^{-5} \cos \theta_1 (A_1 / A_2) \times J_2 \times A_2 \right) / A_1 = 3.20 \times 10^{-5} \cos \theta_1 \cdot J_2 \quad (5)$$

$$G_1 = 3.20 \times 10^{-5} \cos(30^\circ) \times 5580 \text{ W/m}^2 = 27.7 \text{ } \mu\text{W/m}^2. \quad <$$

**COMMENTS:** (1) Note from Eq. (5) that  $G_1 \sim \cos \theta_1$  such that  $G_1$  is a maximum when  $A_1$  is normal to disk  $A_2$ .

### PROBLEM 13.16

**KNOWN:** Heat flux gage positioned normal to a blackbody furnace. Cover of furnace is at 350 K while surroundings are at 300 K.

**FIND:** (a) Irradiation on gage,  $G_g$ , considering only emission from the furnace aperture and (b) Irradiation considering radiation from the cover *and* aperture.

**SCHEMATIC:**

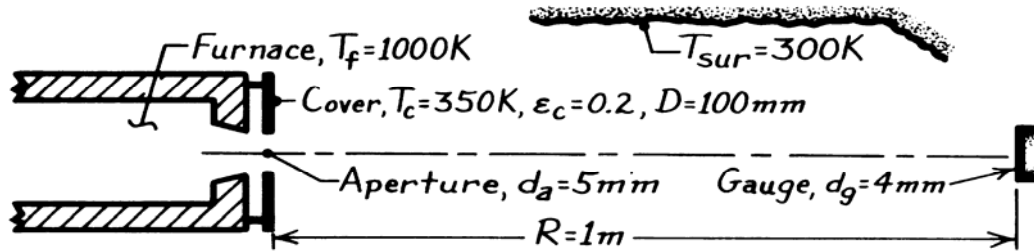

**ASSUMPTIONS:** (1) Furnace aperture approximates blackbody, (2) Shield is opaque, diffuse and gray with uniform temperature, (3) Shield has uniform radiosity, (4)  $A_g \ll R^2$ , so that  $\omega_{g-f} = A_g/R^2$ , (5) Surroundings are large, uniform at 300 K.

**ANALYSIS:** (a) The irradiation on the gage due *only* to aperture emission is

$$G_g = q_{f-g} / A_g = (I_{e,f} \cdot A_f \cos \theta_f \cdot \omega_{g-f}) / A_g = \frac{\sigma T_f^4}{\pi} \cdot A_f \cdot \frac{A_g}{R^2} / A_g$$

$$G_g = \frac{\sigma T_f^4}{\pi R^2} A_f = \frac{5.67 \times 10^{-8} \text{ W/m}^2 \cdot \text{K}^4 (1000 \text{ K})^4}{\pi (1 \text{ m})^2} \times (\pi/4) (0.005 \text{ m})^2 = 354.4 \text{ mW/m}^2. \quad <$$

(b) The irradiation on the gage due to radiation from the *aperture* (a) and *cover* (c) is

$$G_g = G_{g,a} + \frac{F_{c-g} \cdot J_c A_c}{A_g}$$

where  $F_{c-g}$  and the cover radiosity are

$$F_{c-g} = F_{g-c} \left( A_g / A_c \right) \approx \frac{D_c^2}{4R^2 + D_c^2} \cdot \frac{A_g}{A_c} \quad J_c = \epsilon_c E_b(T_c) + \rho_c G_c$$

but  $G_c = E_b(T_{sur})$  and  $\rho_c = 1 - \alpha_c = 1 - \epsilon_c$ ,  $J_c = \epsilon_c \sigma T_c^4 + (1 - \epsilon_c) \sigma T_{sur}^4 = (170.2 + 387.4) \text{ W/m}^2$ . Hence, the irradiation is

$$G_g = G_{g,a} + \frac{1}{A_g} \left( \frac{D_c^2}{4R^2 + D_c^2} \cdot \frac{A_g}{A_c} \right) \left[ \epsilon_c \sigma T_c^4 + (1 - \epsilon_c) \sigma T_{sur}^4 \right] A_c$$

$$G_g = 354.4 \text{ mW/m}^2 + \left( \frac{0.10^2}{4 \times 1^2 + 0.10^2} \right) \left[ 0.2 \times \sigma (350)^4 + (1 - 0.2) \times \sigma (300)^4 \right] \text{ W/m}^2$$

$$G_g = 354.4 \text{ mW/m}^2 + 424.4 \text{ mW/m}^2 + 916.2 \text{ mW/m}^2 = 1,695 \text{ mW/m}^2.$$

**COMMENTS:** (1) Note we have assumed  $A_f \ll A_c$  so that effect of the aperture is negligible. (2) In part (b), the irradiation due to radiosity from the shield can be written also as  $G_{g,c} = q_{c-g}/A_g = (J_c/\pi) \cdot A_c \cdot \omega_{g-c}/A_g$  where  $\omega_{g-c} = A_g/R^2$ . This is an excellent approximation since  $A_c \ll R^2$ .



### PROBLEM 13.17

**KNOWN:** Temperature and diameters of a circular ice rink and a hemispherical dome.

**FIND:** Net rate of heat transfer to the ice due to radiation exchange with the dome.

**SCHEMATIC:**

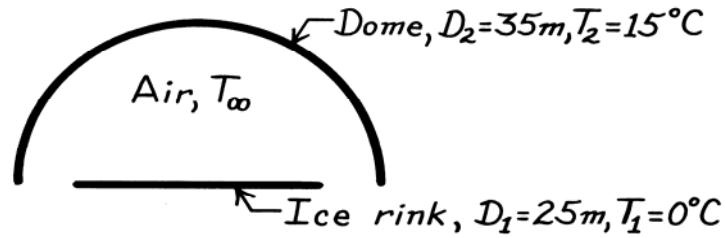

**ASSUMPTIONS:** (1) Blackbody behavior for dome and ice. (2) Surfaces have uniform irradiation and radiosity.

**ANALYSIS:** From Eq. 13.13,

$$q_{21} = A_2 F_{21} \sigma (T_2^4 - T_1^4)$$

From reciprocity,  $A_2 F_{21} = A_1 F_{12} = \left( \pi D_1^2 / 4 \right) 1$

$$A_2 F_{21} = (\pi / 4) (25 \text{ m})^2 1 = 491 \text{ m}^2.$$

Hence

$$q_{21} = 491 \text{ m}^2 \left( 5.67 \times 10^{-8} \text{ W/m}^2 \cdot \text{K}^4 \right) \left[ (288 \text{ K})^4 - (273 \text{ K})^4 \right]$$

$$q_{21} = 3.69 \times 10^4 \text{ W.} \quad <$$

**COMMENTS:** (1) If the air temperature,  $T_\infty$ , exceeds  $T_1$ , there will also be heat transfer by convection to the ice. The radiation and convection transfer to the ice determine the heat load which must be handled by the cooling system. (2) Because they are isothermal and black, the two surfaces have uniform radiosity. Do you expect them each to be uniformly irradiated? Would non-uniform irradiation of either surface affect the answer?

### PROBLEM 13.18

**KNOWN:** Surface temperature of a semi-circular drying oven.

**FIND:** Drying rate per unit length of oven.

**SCHEMATIC:**

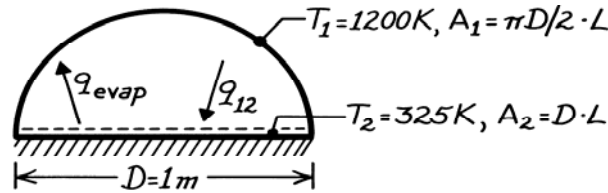

**ASSUMPTIONS:** (1) Blackbody behavior for furnace wall and water, (2) Convection effects are negligible and bottom is insulated, (3) Uniform surface irradiation and radiosity.

**PROPERTIES:** Table A-6, Water (325 K):  $h_{fg} = 2.378 \times 10^6 \text{ J/kg}$ .

**ANALYSIS:** Applying a surface energy balance,

$$q_{12} = q_{\text{evap}} = \dot{m} h_{fg}$$

where it is assumed that the net radiation heat transfer to the water is balanced by the evaporative heat loss. From Eq. 13.13,

$$q_{12} = A_1 F_{12} \sigma (T_1^4 - T_2^4).$$

From inspection and the reciprocity relation,

$$F_{12} = \frac{A_2}{A_1} F_{21} = \frac{D \cdot L}{(\pi D/2) \cdot L} \times 1 = 0.637.$$

Hence

$$\dot{m}' = \frac{\dot{m}}{L} = \frac{\pi D}{2} F_{12} \sigma \frac{(T_1^4 - T_2^4)}{h_{fg}}$$

$$\dot{m}' = \frac{\pi(1 \text{ m})}{2} \times 0.637 \times 5.67 \times 10^{-8} \frac{\text{W}}{\text{m}^2 \cdot \text{K}^4} \frac{(1200 \text{ K})^4 - (325 \text{ K})^4}{2.378 \times 10^6 \text{ J/kg}}$$

or

$$\dot{m}' = 0.0492 \text{ kg/s} \cdot \text{m.}$$

<

**COMMENTS:** (1) Air flow through the oven is needed to remove the water vapor. The water surface temperature,  $T_2$ , is determined by a balance between radiation heat transfer to the water and the convection of latent and sensible energy from the water. (2) Because the surfaces are black and isothermal, they have uniform radiosity.

### PROBLEM 13.19

**KNOWN:** Arrangement of three black surfaces with prescribed geometries and surface temperatures.

**FIND:** (a) View factor  $F_{13}$ , (b) Net radiation heat transfer from  $A_1$  to  $A_3$ .

**SCHEMATIC:**

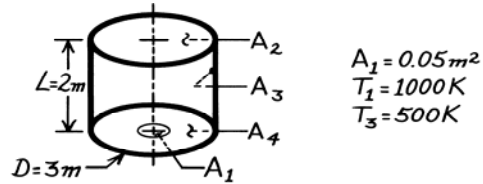

**ASSUMPTIONS:** (1) Interior surfaces behave as blackbodies, (2)  $A_2 \gg A_1$ , (3) Surfaces are uniformly irradiated and have uniform radiosities.

**ANALYSIS:** (a) Define the enclosure as the interior of the cylindrical form and identify  $A_4$ . Applying the view factor summation rule, Eq. 13.4,

$$F_{11} + F_{12} + F_{13} + F_{14} = 1. \quad (1)$$

Note that  $F_{11} = 0$  and  $F_{14} = 0$ . From Eq. 13.8,

$$F_{12} = \frac{D^2}{D^2 + 4L^2} = \frac{(3\text{m})^2}{(3\text{m})^2 + 4(2\text{m})^2} = 0.36. \quad (2)$$

From Eqs. (1) and (2),

$$F_{13} = 1 - F_{12} = 1 - 0.36 = 0.64. \quad <$$

(b) From Eq. 13.13,

$$q_{13} = A_1 F_{13} \sigma (T_1^4 - T_3^4)$$

$$q_{13} = 0.05\text{m}^2 \times 0.64 \times 5.67 \times 10^{-8} \text{W/m}^2 \cdot \text{K}^4 (1000^4 - 500^4) \text{K}^4 = 1700 \text{W}. \quad <$$

**COMMENTS:** (1) Note that the summation rule, Eq. 13.4, applies to an enclosure; that is, the total region above the surface must be considered. (2) Because the surfaces are black and isothermal, their radiosities are uniform. Is the irradiation of each surface uniform?

### PROBLEM 13.20

**KNOWN:** Furnace diameter and temperature. Dimensions and temperature of suspended part.

**FIND:** Net rate of radiation transfer per unit length to the part.

**SCHEMATIC:**

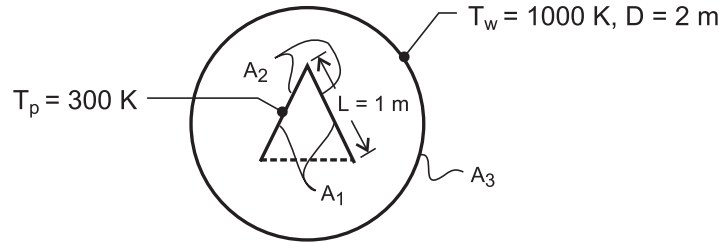

**ASSUMPTIONS:** (1) All surfaces may be approximated as blackbodies. (2) Uniform surface irradiation and radiosity.

**ANALYSIS:** From symmetry considerations, it is convenient to treat the system as a three-surface enclosure consisting of the inner surfaces of the vee (1), the outer surfaces of the vee (2) and the furnace wall (3). The net rate of radiation heat transfer to the part is then

$$q'_{w,p} = A'_3 F_{31} \sigma (T_w^4 - T_p^4) + A'_3 F_{32} \sigma (T_w^4 - T_p^4)$$

From reciprocity,

$$A'_3 F_{31} = A'_1 F_{13} = 2L \times 0.5 = 1\text{ m}$$

where surface 3 may be represented by the dashed line and, from symmetry,  $F_{13} = 0.5$ . Also,

$$A'_3 F_{32} = A'_2 F_{23} = 2L \times 1 = 2\text{ m}$$

Hence,

$$q'_{w,p} = (1+2)\text{ m} \times 5.67 \times 10^{-8} \text{ W/m}^2 \cdot \text{K}^4 (1000^4 - 300^4) \text{ K}^4 = 1.69 \times 10^5 \text{ W/m} <$$

**COMMENTS:** (1) With all surfaces approximated as blackbodies, the result is independent of the tube diameter. (2) Note that  $F_{11} = 0.5$ . (3) Because the surfaces are approximated as blackbodies and are isothermal they have uniform radiosity. The irradiation of the surfaces is, however, non-uniform. Will this affect the answer?

### PROBLEM 13.21

**KNOWN:** Coaxial, parallel black plates with surroundings. Lower plate ( $A_2$ ) maintained at prescribed temperature  $T_2$  while electrical power is supplied to upper plate ( $A_1$ ).

**FIND:** Temperature of the upper plate  $T_1$ .

**SCHEMATIC:**

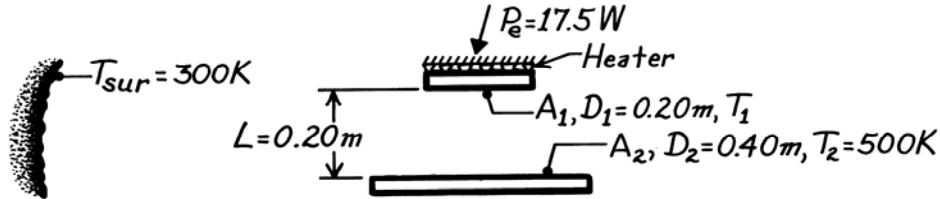

**ASSUMPTIONS:** (1) Plates are black surfaces of uniform temperature. (2) Backside of heater on  $A_1$  insulated. (3) Uniform surface irradiation and radiosity.

**ANALYSIS:** The net radiation heat rate leaving  $A_i$  is

$$P_e = \sum_{j=1}^N q_{ij} = A_1 F_{12} \sigma (T_1^4 - T_2^4) + A_1 F_{13} \sigma (T_1^4 - T_3^4)$$

$$P_e = A_1 \sigma \left[ F_{12} (T_1^4 - T_2^4) + F_{13} (T_1^4 - T_{sur}^4) \right] \quad (1)$$

From Fig. 13.5 for coaxial disks (see Table 13.2),

$$R_1 = r_1 / L = 0.10 \text{ m} / 0.20 \text{ m} = 0.5 \qquad R_2 = r_2 / L = 0.20 \text{ m} / 0.20 \text{ m} = 1.0$$

$$S = 1 + \frac{1 + R_2^2}{R_1^2} = 1 + \frac{1 + 1^2}{(0.5)^2} = 9.0$$

$$F_{12} = \frac{1}{2} \left\{ S - \left[ S^2 - 4(r_2 / r_1)^2 \right]^{1/2} \right\} = \frac{1}{2} \left\{ 9 - \left[ 9^2 - 4(0.2/0.1)^2 \right]^{1/2} \right\} = 0.469.$$

From the summation rule for the enclosure  $A_1$ ,  $A_2$  and  $A_3$  where the last area represents the surroundings with  $T_3 = T_{sur}$ ,  $F_{12} + F_{13} = 1$  and  $F_{13} = 1 - F_{12} = 1 - 0.469 = 0.531$ .

Substituting numerical values into Eq. (1), with  $A_1 = \pi D_1^2 / 4 = 3.142 \times 10^{-2} \text{ m}^2$ ,

$$17.5 \text{ W} = 3.142 \times 10^{-2} \text{ m}^2 \times 5.67 \times 10^{-8} \text{ W/m}^2 \cdot \text{K}^4 \left[ 0.469 (T_1^4 - 500^4) \text{K}^4 \right. \\ \left. + 0.531 (T_1^4 - 300^4) \text{K}^4 \right]$$

$$9.823 \times 10^9 = 0.469 (T_1^4 - 500^4) + 0.531 (T_1^4 - 300^4)$$

we find that  $T_1 = 456 \text{ K}$ .

<

**COMMENTS:** (1) Note that if the upper plate were adiabatic,  $T_1 = 427 \text{ K}$ . (2) Would you expect the surfaces to experience uniform irradiation? If the heater were constructed of a low thermal conductivity material, temperature gradients would likely develop in the radial direction. If this were the case, the heater surface would no longer be isothermal, and would no longer have a uniform radiosity. A more detailed analysis involving more radiation surface might be warranted in practice.

### PROBLEM 13.22

**KNOWN:** Dimensions and separation distance of coaxial, parallel black plates. Temperatures of lower plate and surroundings. Electrical power supplied to upper plate.

**FIND:** Temperature of the upper plate for circular and square plates and dependence on separation distance.

**SCHEMATIC:**

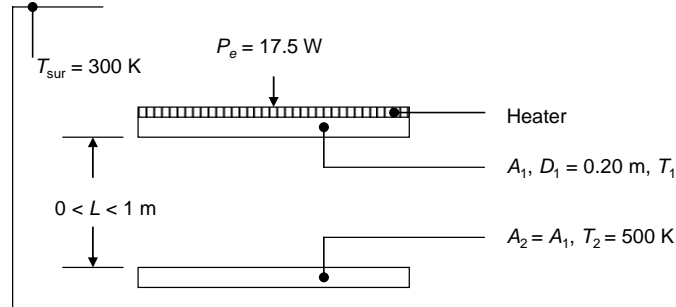

**ASSUMPTIONS:** (1) Plates are black surfaces of uniform temperature. (2) Backside of heater on  $A_1$  insulated. (3) Surfaces have uniform irradiation and radiosity.

**ANALYSIS:** The net radiation heat rate leaving  $A_1$  is

$$P_e = \sum_{j=1}^N q_{ij} = A_1 F_{12} \sigma (T_1^4 - T_2^4) + A_1 F_{13} \sigma (T_1^4 - T_{\text{sur}}^4)$$

$$P_e = A_1 \sigma \left[ F_{12} (T_1^4 - T_2^4) + F_{13} (T_1^4 - T_{\text{sur}}^4) \right] \quad (1)$$

From Table 13.2 for coaxial disks (or Fig. 13.5),

$$R_1 = R_2 = r / L = 0.10 \text{ m} / 0.20 \text{ m} = 0.5$$

$$S = 1 + \frac{1 + R_2^2}{R_1^2} = 1 + \frac{1 + (0.5)^2}{(0.5)^2} = 6$$

$$F_{12} = \frac{1}{2} \left\{ S - \left[ S^2 - 4(r_2 / r_1)^2 \right]^{1/2} \right\} = \frac{1}{2} \left\{ 6 - \left[ 6^2 - 4 \right]^{1/2} \right\} = 0.172.$$

From the summation rule for the enclosure  $A_1$ ,  $A_2$ , and  $A_3$  where the last area represents the surroundings with  $T_3 = T_{\text{sur}}$ ,

$$F_{12} + F_{13} = 1 \quad F_{13} = 1 - F_{12} = 1 - 0.172 = 0.828.$$

From Eq. (1), with  $A_1 = \pi D_1^2 / 4 = 3.142 \times 10^{-2} \text{ m}^2$ ,

$$T_1 = \left[ \frac{\left( \frac{P_e}{A_1 \sigma} + F_{12} T_2^4 + F_{13} T_{\text{sur}}^4 \right)}{F_{12} + F_{13}} \right]^{1/4} \quad (2)$$

Continued...

**PROBLEM 13.22 (Cont.)**

$$T_1 = \left[ \frac{\left( \frac{17.5 \text{ W}}{3.142 \times 10^{-2} \text{ m}^2 \times 5.67 \times 10^{-8} \text{ W / m}^2 \cdot \text{K}^4} + 0.172 \times 500^4 \text{ K}^4 + 0.828 \times 300^4 \text{ K}^4 \right)}{1} \right]^{1/4}$$

$$T_1 = 406 \text{ K.}$$

<

For the coaxial squares,  $X = (\pi/4)^{1/2} D = 0.177 \text{ m}$ . Then  $F_{12}$  is found from Table 13.2 for aligned rectangles (or Fig. 13.4),

$$\bar{X} = \bar{Y} = X / L = 0.177 \text{ m} / 0.20 \text{ m} = 0.886$$

$$F_{12} = \frac{2}{\pi \bar{X}^2} \left\{ \ln \left[ \frac{(1 + \bar{X}^2)^2}{1 + 2\bar{X}^2} \right]^{1/2} + 2\bar{X}(1 + \bar{X}^2)^{1/2} \tan^{-1} \left[ \frac{\bar{X}}{(1 + \bar{X}^2)^{1/2}} \right] - 2\bar{X} \tan^{-1} \bar{X} \right\} = 0.170.$$

Then,

$$F_{12} + F_{13} = 1 \quad F_{13} = 1 - F_{12} = 1 - 0.170 = 0.830.$$

Finally, from Eq. (2)

$$T_1 = \left[ \frac{\left( \frac{17.5 \text{ W}}{3.142 \times 10^{-2} \text{ m}^2 \times 5.67 \times 10^{-8} \text{ W / m}^2 \cdot \text{K}^4} + 0.170 \times 500^4 \text{ K}^4 + 0.830 \times 300^4 \text{ K}^4 \right)}{1} \right]^{1/4}$$

$$T_1 = 406 \text{ K.}$$

<

Continued...

### PROBLEM 13.22 (Cont.)

Results were generated for  $0 < L \leq 1$  m using IHT and are shown below. The results for the circular disks and aligned squares are plotted together and are virtually indistinguishable.

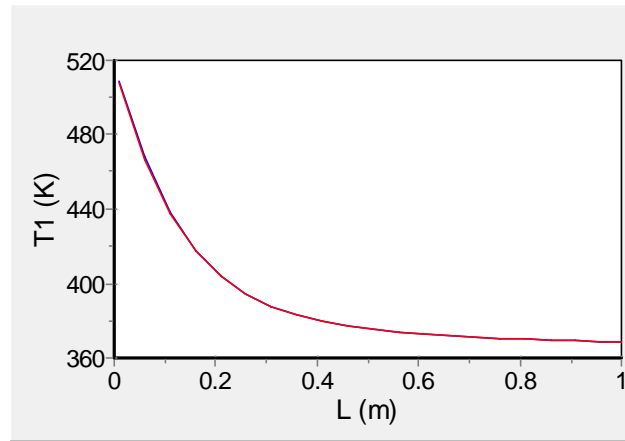

<

**COMMENTS:** (1) For either geometry, as the plates approach one another the cooling effect of the surroundings vanishes, and the temperature of plate 1 adjusts to adhere to an energy balance between the power supplied by the heater and the heat loss to plate 2 at 500 K. That is,  $P_e = A_1 \sigma (T_1^4 - T_2^4)$ , resulting in  $T_1 = 519$  K. (2) As the plates become far apart, the effect of plate 2 on plate 1 vanishes. The temperature of plate 1 adjusts to adhere to an energy balance between the power supplied by the heater and the heat loss to the cool surroundings. That is,  $P_e = A_1 \sigma (T_1^4 - T_2^4)$ , resulting in  $T_1 = 366$  K. (3) The shape factors for the two geometries are nearly the same and therefore the temperature of plate 1 is almost the same for either geometry. (4) The surfaces are not uniformly irradiated. If the heater were constructed of low thermal conductivity material, it may experience a spatial temperature distribution. As such, it would no longer be isothermal and would no longer have a uniform radiosity. A more detailed analysis involving many radiation surfaces may be warranted in practice.



### PROBLEM 13.23

**KNOWN:** Tubular heater radiates like blackbody at 1000 K.

**FIND:** (a) Radiant power from the heater surface,  $A_s$ , intercepted by a disc,  $A_1$ , at a prescribed location  $q_{s \rightarrow 1}$ ; irradiation on the disk,  $G_1$ ; and (b) Compute and plot  $q_{s \rightarrow 1}$  and  $G_1$  as a function of the separation distance  $L_1$  for the range  $0 \leq L_1 \leq 200$  mm for disk diameters  $D_1 = 25$ , and 50 and 100 mm.

**SCHEMATIC:**

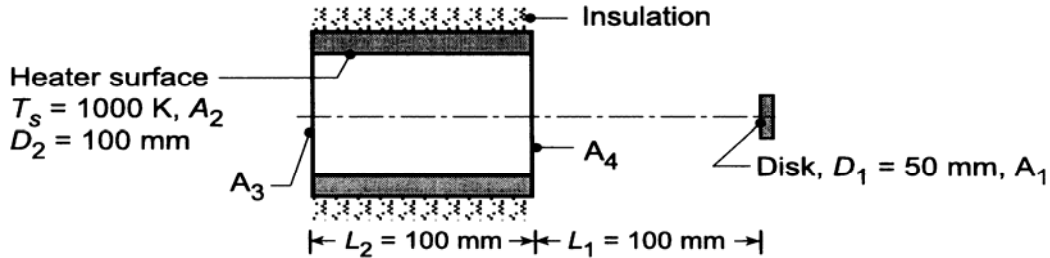

**ASSUMPTIONS:** (1) Heater surface behaves as blackbody with uniform temperature. (2) Surfaces have uniform radiosity and irradiation.

**ANALYSIS:** (a) The radiant power leaving the inner surface of the tubular heater that is intercepted by the disk is

$$q_{2 \rightarrow 1} = (A_2 E_{b2}) F_{21} \quad (1)$$

where the heater is surface 2 and the disk is surface 1. It follows from the reciprocity rule, Eq. 13.3, that

$$F_{21} = \frac{A_1}{A_2} F_{12}. \quad (2)$$

Define now the hypothetical disks,  $A_3$  and  $A_4$ , located at the ends of the tubular heater. By inspection, it follows that

$$F_{14} = F_{12} + F_{13} \quad \text{or} \quad F_{12} = F_{14} - F_{13} \quad (3)$$

where  $F_{14}$  and  $F_{13}$  may be determined from Fig. 13.5. Substituting numerical values, with  $D_3 = D_4 = D_2$ ,

$$F_{13} = 0.08 \quad \text{with} \quad \frac{L}{r_i} = \frac{L_1 + L_2}{D_1/2} = \frac{200}{50/2} = 8 \quad \frac{r_j}{L} = \frac{D_3/2}{L_1 + L_2} = \frac{100/2}{200} = 0.25$$

$$F_{14} = 0.20 \quad \text{with} \quad \frac{L}{r_i} = \frac{L_1}{D_1/2} = \frac{100}{50/2} = 4 \quad \frac{r_j}{L} = \frac{D_4/2}{L_1} = \frac{100/2}{100} = 0.5$$

Substituting Eq. (3) into Eq. (2) and then into Eq. (1), the result is

$$q_{2 \rightarrow 1} = A_1 (F_{14} - F_{13}) E_{b2}$$

$$q_{2 \rightarrow 1} = \left[ \pi (50 \times 10^{-3})^2 / 4 \right] (0.20 - 0.08) \times 5.67 \times 10^{-8} \text{ W/m}^2 \cdot \text{K}^4 (1000 \text{ K})^4 = 13.4 \text{ W} \quad <$$

where  $E_{b2} = \sigma T_s^4$ . The irradiation  $G_1$  originating from emission leaving the heater surface is

$$G_1 = \frac{q_{s \rightarrow 1}}{A_1} = \frac{13.4 \text{ W}}{\pi (0.050 \text{ m})^2 / 4} = 6825 \text{ W/m}^2. \quad (4) <$$

Continued ...

### PROBLEM 13.23 (Cont.)

(b) Using the foregoing equations in *IHT* along with the *Radiation Tool-View Factors* for *Coaxial Parallel Disks*,  $G_1$  and  $q_{s \rightarrow 1}$  were computed as a function of  $L_1$  for selected values of  $D_1$ . The results are plotted below.

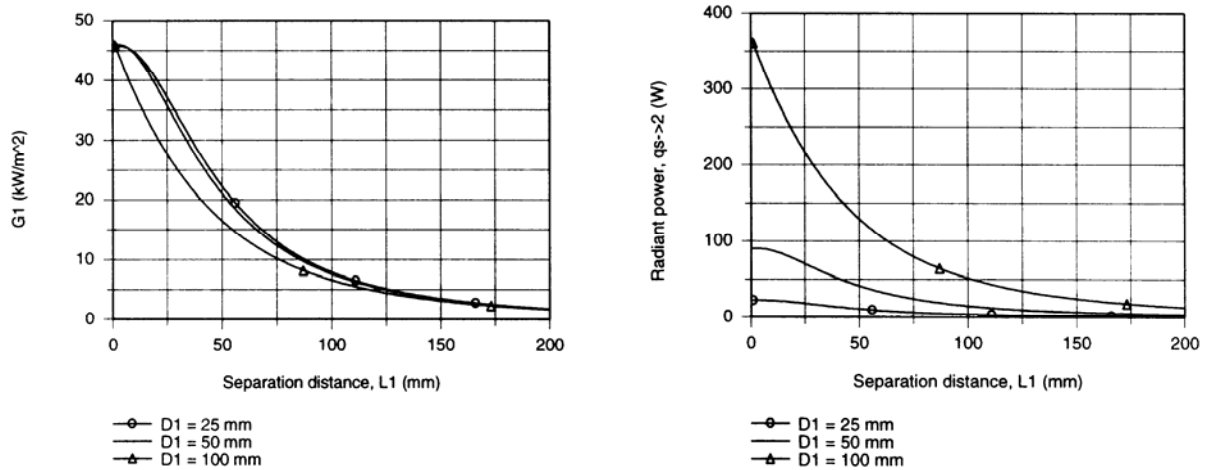

In the upper left-hand plot,  $G_1$  decreases with increasing separation distance. For a given separation distance, the irradiation decreases with increasing diameter. With values of  $D_1 = 25$  and  $50$  mm, the irradiation values are only slightly different, which diminishes as  $L_1$  increases. In the upper right-hand plot, the radiant power from the heater surface reaching the disk,  $q_{s \rightarrow 2}$ , decreases with increasing  $L_1$  and decreasing  $D_1$ . Note that while  $G_1$  is nearly the same for  $D_1 = 25$  and  $50$  mm, their respective  $q_{s \rightarrow 2}$  values are quite different. Why is this so?

Comment. Since the tube surface is assumed to be black and isothermal, it will have uniform radiosity distributions. However, its irradiation is not uniform. Will the nonuniformity of the irradiation affect the answer?

### PROBLEM 13.24

**KNOWN:** Circular plate ( $A_1$ ) maintained at 600 K positioned coaxially with a conical shape ( $A_2$ ) whose backside is insulated. Plate and cone are black surfaces and located in large, insulated enclosure at 300 K.

**FIND:** (a) Temperature of the conical surface  $T_2$  and (b) Electric power required to maintain plate at 600 K.

**SCHEMATIC:**

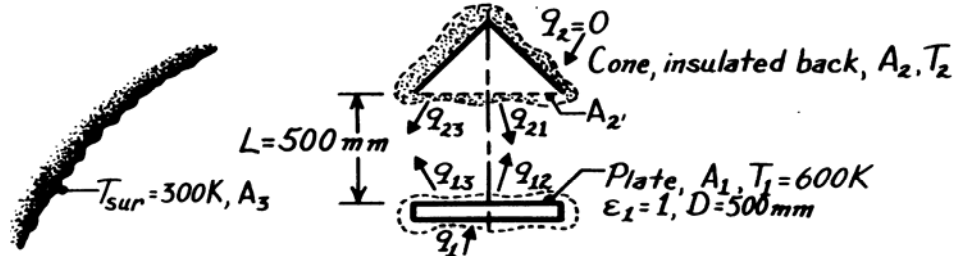

**ASSUMPTIONS:** (1) Steady-state conditions, (2) Plate and cone are black, (3) Cone behaves as insulated, reradiating surface, (4) Surroundings are large compared to plate and cone, (5) Uniform irradiation and radiosity.

**ANALYSIS:** (a) Recognizing that the plate, cone, and surroundings form a three-(black) surface enclosure, perform a radiation balance on the cone.

$$q_2 = 0 = q_{23} + q_{21} = A_2 F_{23} \sigma (T_2^4 - T_3^4) + A_2 F_{21} \sigma (T_2^4 - T_1^4)$$

where the view factor  $F_{21}$  can be determined from the *coaxial parallel disks* relation (Table 13.2 or Fig. 13.5) with  $R_i = r_i/L = 250/500 = 0.5$ ,  $R_j = 0.5$ ,  $S = 1 + (1 + R_j^2)/R_i^2 = 1 + (1 + 0.5^2)/0.5^2 = 6.00$ , and noting  $F_{2'1} = F_{21}$ ,

$$F_{21} = 0.5 \left\{ S - \left[ S^2 - 4 \left( r_j / r_i \right)^2 \right]^{1/2} \right\} = 0.5 \left\{ 6 - \left[ 6^2 - 4 (0.5 / 0.5)^2 \right]^{1/2} \right\} = 0.172.$$

For the enclosure, the summation rule provides,  $F_{2'3} = 1 - F_{2'1} = 1 - 0.172 = 0.828$ . Hence,

$$0.828 (T_2^4 - 300^4) = 0 + 0.172 (T_2^4 - 600^4)$$

$$T_2 = 413 \text{ K.} \quad <$$

(b) The power required to maintain the plate at  $T_2$  follows from a radiation balance,

$$q_1 = q_{12} + q_{13} = A_1 F_{12} \sigma (T_1^4 - T_2^4) + A_1 F_{13} \sigma (T_1^4 - T_3^4)$$

where  $F_{12} = A_2' F_{2'1} / A_1 = F_{21} = 0.172$  and  $F_{13} = 1 - F_{12} = 0.828$ ,

$$q_1 = (\pi 0.5^2 / 4) \text{ m}^2 \sigma \left[ 0.172 (600^4 - 413^4) \text{ K}^4 + 0.828 (600^4 - 300^4) \text{ K}^4 \right]$$

$$q_1 = 1312 \text{ W.} \quad <$$

**Comment:** Because the surfaces are black and isothermal, they each are characterized by a uniform radiosity. Will the non-uniformity of the irradiation of the surfaces affect the answer?

### PROBLEM 13.25

**KNOWN:** Conical and cylindrical furnaces ( $A_2$ ) as illustrated and dimensioned in Problem 13.4 supplied with power of 50 W. Workpiece ( $A_1$ ) with insulated backside located in large room at 300 K.

**FIND:** Temperature of the workpiece,  $T_1$ , and the temperature of the inner surfaces of the furnaces,  $T_2$ . Use expressions for the view factors  $F_{21}$  and  $F_{22}$  given in the statement for Problem 13.4.

**SCHEMATIC:**

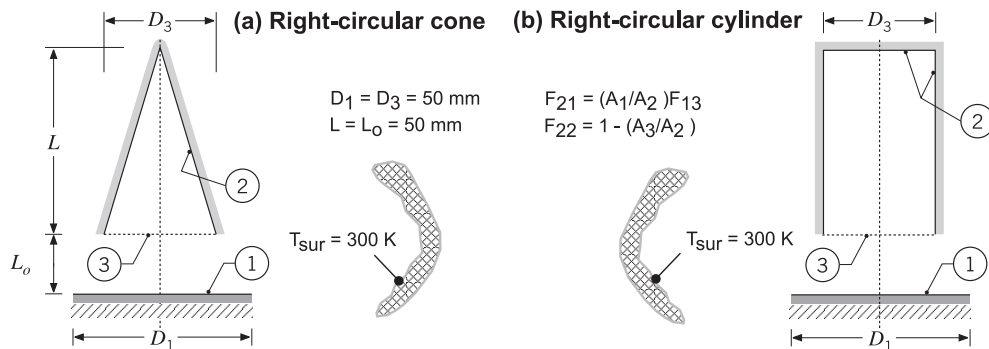

**ASSUMPTIONS:** (1) Diffuse, black surfaces with uniform radiosities, (2) Backside of workpiece is perfectly insulated, (3) Inner base and lateral surfaces of the cylindrical furnace treated as single surface, (4) Negligible convection heat transfer, (5) Room behaves as large, isothermal surroundings.

**ANALYSIS:** Considering the furnace surface ( $A_2$ ), the workpiece ( $A_1$ ) and the surroundings ( $A_s$ ) as an enclosure, the net radiation transfer from  $A_1$  and  $A_2$  follows from Eq. 13.13,

$$\text{Workpiece} \quad q_1 = 0 = A_1 F_{12} (E_{b1} - E_{b2}) + A_1 F_{1s} (E_{b1} - E_{bs}) \quad (1)$$

$$\text{Furnace} \quad q_2 = 50 \text{ W} = A_2 F_{21} (E_{b2} - E_{b1}) + A_2 F_{2s} (E_{b2} - E_{bs}) \quad (2)$$

where  $E_b = \sigma T^4$  and  $\sigma = 5.67 \times 10^{-8} \text{ W/m}^2 \cdot \text{K}^4$ . From summation rules on  $A_1$  and  $A_2$ , the view factors  $F_{1s}$  and  $F_{2s}$  can be evaluated. Using reciprocity,  $F_{12}$  can be evaluated.

$$F_{1s} = 1 - F_{12} \quad F_{2s} = 1 - F_{21} - F_{22} \quad F_{12} = (A_2 / A_1) F_{21}$$

The expressions for  $F_{21}$  and  $F_{22}$  are provided in the schematic. With  $A_1 = \pi D_1^2 / 4$  the  $A_2$  are:

$$\text{Cone: } A_2 = \pi D_3 / 2 \left( L^2 + (D_3 / 2)^2 \right)^{1/2} \quad \text{Cylinder: } A_2 = \pi D_3^2 / 4 + \pi D_3 L$$

Examine Eqs (1) and (2) and recognize that there are two unknowns,  $T_1$  and  $T_2$ , and the equations must be solved simultaneously. Using the foregoing equations in the *IHT* workspace, the results are

$$T_1 = 544 \text{ K} \quad T_2 = 828 \text{ K} \quad \leftarrow$$

**COMMENTS:** (1) From the *IHT* analysis, the relevant view factors are:  $F_{12} = 0.1716$ ;  $F_{1s} = 0.8284$ ; *Cone:*  $F_{21} = 0.07673$ ,  $F_{22} = 0.5528$ ; *Cylinder:*  $F_{21} = 0.03431$ ,  $F_{22} = 0.80$ . (2) That both furnace configurations provided identical results may not, at first, be intuitively obvious. Since both furnaces ( $A_2$ ) are black, they can be represented by the hypothetical black area  $A_3$  (the opening of the furnaces). As such, the analysis is for an enclosure with the workpiece ( $A_1$ ), the furnace represented by the disk  $A_3$  (at  $T_2$ ), and the surroundings. As an exercise, perform this analysis to confirm the above results. (3) Since the surfaces are assumed to be black and isothermal, their radiosities are uniform. The irradiation of the surfaces is not uniform. This may lead to non-uniform temperature distributions in the workpiece in a real application.

### PROBLEM 13.26

**KNOWN:** Furnace constructed in three sections: insulated circular (2) and cylindrical (3) sections, as well as, an intermediate cylindrical section (1) with imbedded electrical resistance heaters. Cylindrical sections (1,3) are of equal length.

**FIND:** (a) Electrical power required to maintain the heated section at  $T_1 = 1000$  K if all the surfaces are black, (b) Temperatures of the insulated sections,  $T_2$  and  $T_3$ , and (c) Compute and plot  $q_1$ ,  $T_2$  and  $T_3$  as functions of the length-to-diameter ratio, with  $1 \leq L/D \leq 5$  and  $D = 100$  mm.

**SCHEMATIC:**

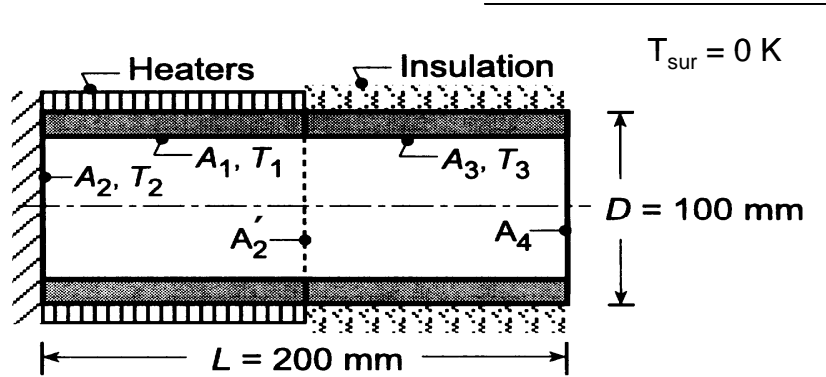

**ASSUMPTIONS:** (1) All surfaces are black, (2) Areas (1, 2, 3) are isothermal. (3) Uniform surface radiosity and irradiation.

**ANALYSIS:** (a) To complete the enclosure representing the furnace, define the hypothetical surface  $A_4$  as the opening at 0 K with unity emissivity. For each of the enclosure surfaces 1, 2, and 3, the energy balances following Eq. 13.13 are

$$q_1 = A_1 F_{12} (E_{b1} - E_{b2}) + A_1 F_{13} (E_{b1} - E_{b3}) + A_1 F_{14} (E_{b1} - E_{b4}) \quad (1)$$

$$0 = A_2 F_{21} (E_{b2} - E_{b1}) + A_2 F_{23} (E_{b2} - E_{b3}) + A_2 F_{24} (E_{b2} - E_{b4}) \quad (2)$$

$$0 = A_3 F_{31} (E_{b3} - E_{b1}) + A_3 F_{32} (E_{b3} - E_{b2}) + A_3 F_{34} (E_{b3} - E_{b4}) \quad (3)$$

where the emissive powers are

$$E_{b1} = \sigma T_1^4 \quad E_{b2} = \sigma T_2^4 \quad E_{b3} = \sigma T_3^4 \quad E_{b4} = 0 \quad (4-7)$$

For this four surface enclosure, there are  $N^2 = 16$  view factors and  $N(N-1)/2 = 4 \times 3/2 = 6$  must be directly determined (by inspection or formulas) and the remainder can be evaluated from the summation rule and reciprocity relation. By inspection,

$$F_{22} = 0 \quad F_{44} = 0 \quad (8,9)$$

From the coaxial parallel disk relation, Table 13.2, find  $F_{24}$

$$S = 1 + \frac{1 + R_4^2}{R_2^2} = 1 + \frac{1 + (0.250)^2}{(0.250)^2} = 18.00$$

$$R_2 = r_2 / L = 0.050 \text{ m} / 0.200 \text{ m} = 0.250 \quad R_4 = r_4 / L = 0.250$$

$$F_{24} = 0.5 \left\{ S - \left[ S^2 - 4(r_4 / r_2)^2 \right]^{1/2} \right\}$$

$$F_{24} = 0.5 \left\{ 18.00 - \left[ 18.00^2 - 4(1)^2 \right]^{1/2} \right\} = 0.0557 \quad (10)$$

Consider the three-surface enclosure 1-2-2' and find  $F_{11}$  as beginning with the summation rule,

Continued ...

**PROBLEM 13.26 (Cont.)**

$$F_{11} = 1 - F_{12} - F_{12'} \quad (11)$$

where, from symmetry,  $F_{12} = F_{12'}$ , and using reciprocity,

$$F_{12} = A_2 F_{21} / A_1 = \left( \pi D^2 / 4 \right) F_{23} / (\pi D L / 2) = D F_{21} / 2L \quad (12)$$

and from the summation rule on  $A_2$

$$F_{21} = 1 - F_{22'} = 1 - 0.172 = 0.828, \quad (13)$$

Using the coaxial parallel disk relation, Table 13.2, to find  $F_{22'}$ ,

$$S = 1 + \frac{1 + R_2^2}{R_2^2} = 1 + \frac{1 + 0.50^2}{0.50^2} = 6.000$$

$$R_2 = r_2 / L = 0.050 \text{ m} / (0.200 / 2 \text{ m}) = 0.500 \quad R_2' = 0.500$$

$$F_{22'} = 0.5 \left\{ S - \left[ S^2 - 4(r_2' / r_2)^2 \right]^{1/2} \right\}$$

$$F_{22'} = 0.5 \left\{ 6 - \left[ 6^2 - 4(1)^2 \right]^{1/2} \right\} = 0.1716$$

Evaluating  $F_{12}$  from Eq. (12), find

$$F_{12} = 0.100 \text{ m} \times 0.828 / 2 \times 0.200 \text{ m} = 0.2071$$

and evaluating  $F_{11}$  from Eq. (11), find

$$F_{11} = 1 - 2 \times F_{12} = 1 - 2 \times 0.207 = 0.586$$

From symmetry, recognize that  $F_{33} = F_{11}$  and  $F_{43} = F_{21}$ . To this point we have directly determined six view factors (underlined in the matrix below) and the remaining  $F_{ij}$  can be evaluated from the summation rules and appropriate reciprocity relations. The view factors written in matrix form,  $[F_{ij}]$  are.

<u>0.5858</u>	<u>0.2071</u>	0.1781	0.02896
<u>0.8284</u>	<u>0</u>	0.1158	<u>0.05573</u>
0.1781	0.02896	0.5858	0.2071
0.1158	0.05573	0.8284	<u>0</u>

Knowing all the required view factors, the energy balances and the emissive powers, Eqs. (4-6), can be solved simultaneously to obtain:

$q_1 = 255 \text{ W}$	$E_{b2} = 5.02 \times 10^4 \text{ W/m}^2$	$E_{b3} = 2.79 \times 10^4 \text{ W/m}^2$	<
$T_2 = 970 \text{ K}$	$T_3 = 837.5 \text{ K}$		<

Continued ...

### PROBLEM 13.26 (Cont.)

(b) Using the energy balances, Eqs. (1-3), along with the *IHT Radiation Tool, View Factors, Coaxial parallel disks*, a model was developed to calculate  $q_1$ ,  $T_2$ , and  $T_3$  as a function of length  $L$  for fixed diameter  $D = 100$  m. The results are plotted below.

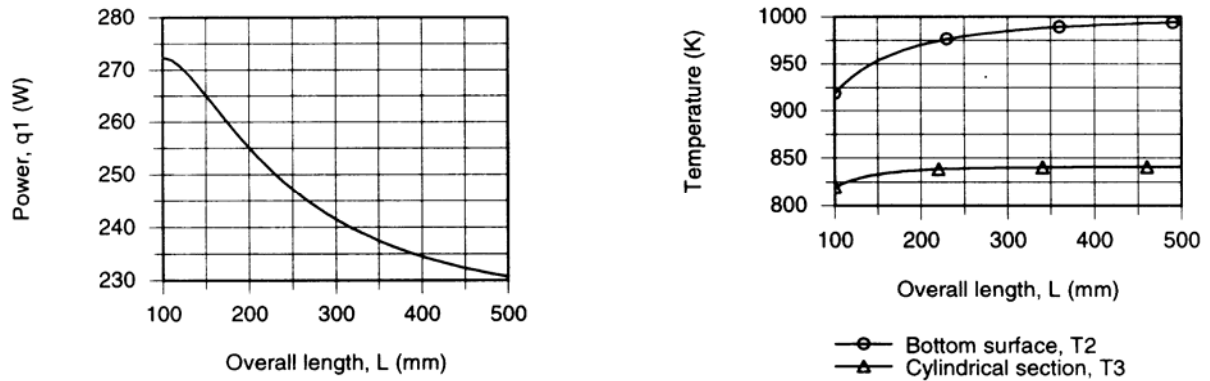

For fixed diameter, as the overall length increases, the power required to maintain the heated section at  $T_1 = 1000$  K decreases. This follows since the furnace opening area is a smaller fraction of the enclosure surface area as  $L$  increases. As  $L$  increases, the bottom surface temperature  $T_2$  increases as  $L$  increases and, in the limit, will approach that of the heated section,  $T_1 = 1000$  K. As  $L$  increases, the temperature of the insulated cylindrical section,  $T_3$ , increases, but only slightly. The limiting value occurs when  $E_{b3} = 0.5 \times E_{b1}$  for which  $T_3 \rightarrow 840$  K. Why is that so?

COMMENT: If the electrical heating is uniformly distributed, the temperature of the heated section will not be uniform. In practice, a more detailed analysis involving more radiation surfaces might be warranted.

### PROBLEM 13.27

**KNOWN:** Dimensions and temperature of a rectangular fin array radiating to deep space.

**FIND:** Expression for rate of radiation transfer per unit length from a unit section of the array.

**SCHEMATIC:**

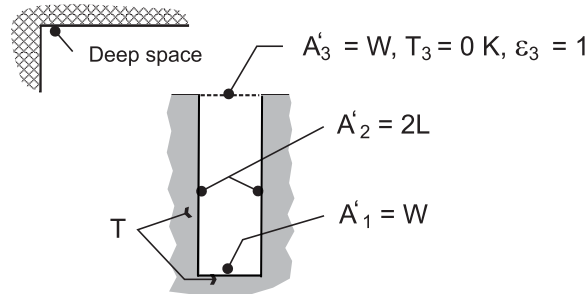

**ASSUMPTIONS:** (1) Surfaces may be approximated as blackbodies, (2) Surfaces are isothermal, (3) Length of array (normal to page) is much larger than  $W$  and  $L$ .

**ANALYSIS:** Deep space may be represented by the hypothetical surface  $A'_3$ , which acts as a blackbody at absolute zero temperature. The net rate of radiation heat transfer to this surface is therefore equivalent to the rate of heat rejection by a unit section of the array.

$$q'_3 = A'_1 F_{13} \sigma (T_1^4 - T_3^4) + A'_2 F_{23} \sigma (T_2^4 - T_3^4)$$

With  $A'_2 F_{23} = A'_3 F_{32} = A'_1 F_{12}$ ,  $T_1 = T_2 = T$  and  $T_3 = 0$ ,

$$q'_3 = A'_1 (F_{13} + F_{12}) \sigma T^4 = W \sigma T^4$$

<

Radiation from a unit section of the array corresponds to emission from the base. Hence, if blackbody behavior can, indeed, be maintained, the fins do nothing to enhance heat rejection.

**COMMENTS:** (1) The foregoing result should come as no surprise since the surfaces of the unit section form an isothermal blackbody cavity for which emission is proportional to the area of the opening. (2) Because surfaces 1 and 2 have the same temperature, the problem could be treated as a two-surface enclosure consisting of the combined (1, 2) and 3. It follows that  $q'_3 = q'_{(1,2)3} = A'_{(1,2)}$

$F_{(1,2)3} \sigma T^4 = A'_3 F_{3(1,2)} \sigma T^4 = W \sigma T^4$ , (3) If blackbody behavior cannot be achieved ( $\epsilon_1, \epsilon_2 < 1$ ), enhancement would be afforded by the fins.



### PROBLEM 13.28

**KNOWN:** Geometry of furnace. Total power. Heat flux is uniform. Temperature of surroundings.

**FIND:** Temperature of four surfaces.

**SCHEMATIC:**

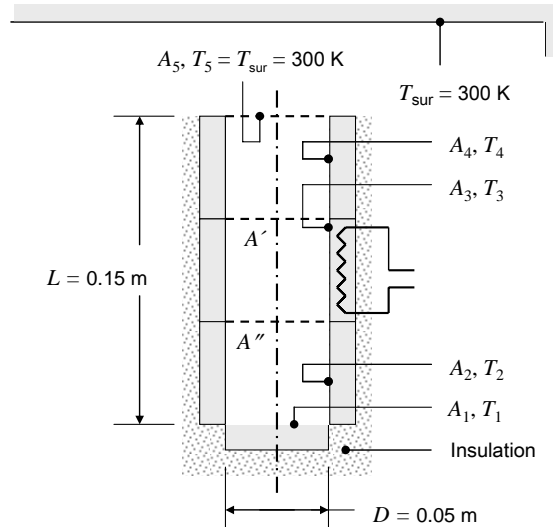

**ASSUMPTIONS:** (1) Interior surfaces behave as blackbodies with uniform temperature, radiosity, and irradiation. (2) Heat transfer by convection is negligible. (3) Backs of electrically-heated surfaces are adiabatic.

**ANALYSIS:** With a total heat loss of  $q = 1522$  W, the heat flux is

$$q'' = \frac{q}{\pi D^2 / 4 + \pi DL} = \frac{1522 \text{ W}}{\pi(0.05 \text{ m})^2 / 4 + \pi \times 0.05 \text{ m} \times 0.15 \text{ m}} = 59,630 \text{ W/m}^2$$

The view factors from the surroundings to the furnace surfaces were found in Example 13.3, but it will be a little easier here to work with the view factors from the furnace surfaces to the surroundings:

$$F_{15} = \frac{A_5 F_{51}}{A_1} = F_{51} = 0.0263$$

$$F_{25} = \frac{A_5 F_{52}}{A_2} = \frac{(\pi D^2 / 4) F_{52}}{\pi DL / 3} = \frac{3D}{4L} F_{52} = \frac{3 \times 0.05 \text{ m}}{4 \times 0.15 \text{ m}} 0.0294 = 0.00735$$

$$F_{35} = \frac{A_5 F_{53}}{A_3} = \frac{3D}{4L} F_{53} = \frac{3 \times 0.05 \text{ m}}{4 \times 0.15 \text{ m}} 0.1163 = 0.0291$$

$$F_{45} = \frac{A_5 F_{54}}{A_4} = \frac{3D}{4L} F_{54} = \frac{3 \times 0.05 \text{ m}}{4 \times 0.15 \text{ m}} 0.828 = 0.207$$

Continued...

### PROBLEM 13.28 (Cont.)

As in Example 13.3, the electric power delivered to each surface balances the corresponding radiation loss. Equations (1)-(4) from Example 13.3 can be solved for the temperatures of each surface.

Recognizing that  $q_1/A_1 = q_2/A_2 = q_3/A_3 = q_4/A_4 = q''$ , we find

$$T_1 = \left( \frac{q_1}{A_1 F_{15} \sigma} + T_5^4 \right)^{1/4} = \left( \frac{q''}{F_{15} \sigma} + T_5^4 \right)^{1/4} = \left( \frac{59,630 \text{ W/m}^2}{0.0263 \times 5.67 \times 10^{-8} \text{ W/m}^2 \cdot \text{K}^4} + 300^4 \text{ K}^4 \right)^{1/4} = 2515 \text{ K} <$$

$$T_2 = \left( \frac{q''}{F_{25} \sigma} + T_5^4 \right)^{1/4} = \left( \frac{59,630 \text{ W/m}^2}{0.00735 \times 5.67 \times 10^{-8} \text{ W/m}^2 \cdot \text{K}^4} + 300^4 \text{ K}^4 \right)^{1/4} = 3459 \text{ K} <$$

$$T_3 = \left( \frac{q''}{F_{35} \sigma} + T_5^4 \right)^{1/4} = \left( \frac{59,630 \text{ W/m}^2}{0.0291 \times 5.67 \times 10^{-8} \text{ W/m}^2 \cdot \text{K}^4} + 300^4 \text{ K}^4 \right)^{1/4} = 2452 \text{ K} <$$

$$T_4 = \left( \frac{q''}{F_{45} \sigma} + T_5^4 \right)^{1/4} = \left( \frac{59,630 \text{ W/m}^2}{0.207 \times 5.67 \times 10^{-8} \text{ W/m}^2 \cdot \text{K}^4} + 300^4 \text{ K}^4 \right)^{1/4} = 1502 \text{ K} <$$

**COMMENTS:** (1) The hottest surface is surface 2, which has the smallest view factor from itself to the surroundings. (2) The large variation in temperature between the four surfaces suggests that the actual temperature of *each* surface would also vary substantially, invalidating the assumptions of uniform radiosity and irradiation. A more accurate analysis could be performed by following the methodology of Comment 3 of Example 13.3.

### PROBLEM 13.29

**KNOWN:** Dimensions and temperatures of side and bottom walls in a cylindrical cavity.

**FIND:** Emissive power of the cavity.

**SCHEMATIC:**

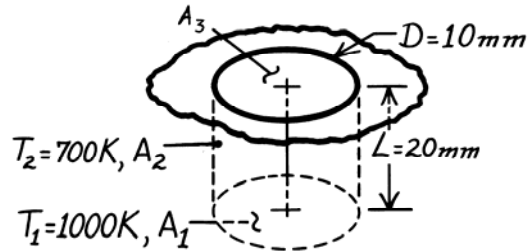

**ASSUMPTIONS:** (1) Blackbody behavior for surfaces 1 and 2. (2) Uniform surface radiosity and irradiation distributions.

**ANALYSIS:** The emissive power is defined as

$$E = q_3 / A_3$$

where

$$q_3 = A_1 F_{13} E_{b1} + A_2 F_{23} E_{b2}.$$

From symmetry,  $F_{23} = F_{21}$ , and from reciprocity,  $F_{21} = (A_1/A_2) F_{12}$ . With  $F_{12} = 1 - F_{13}$ , it follows that

$$q_3 = A_1 F_{13} E_{b1} + A_1 (1 - F_{13}) E_{b2} = A_1 E_{b2} + A_1 F_{13} (E_{b1} - E_{b2}).$$

Hence, with  $A_1 = A_3$ ,

$$E = \frac{q_3}{A_3} = E_{b2} + F_{13} (E_{b1} - E_{b2}) = \sigma T_2^4 + F_{13} \sigma (T_1^4 - T_2^4).$$

From Fig. 13.5, with  $(L/r_i) = 4$  and  $(r_j/L) = 0.25$ ,  $F_{13} \approx 0.05$ . Hence

$$E = 5.67 \times 10^{-8} \text{ W/m}^2 \cdot \text{K}^4 (700^4) \text{K}^4 + 0.05 \times 5.67 \times 10^{-8} \text{ W/m}^2 \cdot \text{K}^4 (1000^4 - 700^4) \text{K}^4$$

$$E = 1.36 \times 10^4 \text{ W/m}^2 + 0.22 \times 10^4 \text{ W/m}^2$$

$$E = 1.58 \times 10^4 \text{ W/m}^2.$$

<

**COMMENT:** (1) The surfaces will not experience uniform irradiation. Will this affect the answer?

### PROBLEM 13.30

**KNOWN:** Aligned, parallel discs with prescribed geometry and orientation.

**FIND:** Net radiative heat exchange between the discs.

**SCHEMATIC:**

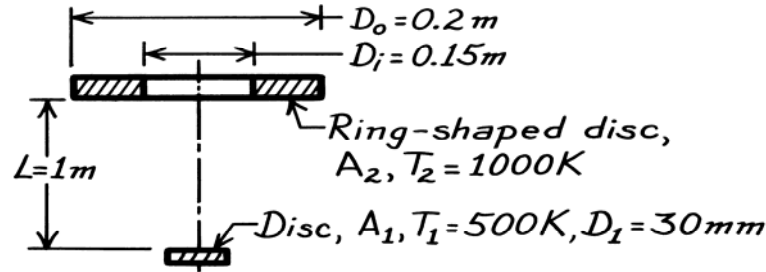

**ASSUMPTIONS:** (1) Surfaces behave as blackbodies, (2)  $A_1 \ll A_2$ .

**ANALYSIS:** From Eq. 13.13

$$q_{12} = A_1 F_{12} \sigma (T_1^4 - T_2^4).$$

The view factor can be determined from Eq. 13.8 which is appropriate for a small disc, aligned and parallel to a much larger disc.

$$F_{ij} = \frac{D_j^2}{D_j^2 + 4L^2}$$

where  $D_j$  is the diameter of the larger disk and  $L$  is the distance of separation. It follows that

$$F_{12} = F_{1o} - F_{1i} = 0.00990 - 0.00559 = 0.00431$$

where

$$F_{1o} = D_o^4 / (D_o^2 + 4L^2) = 0.2^2 \text{ m}^2 / (0.2^2 \text{ m}^2 + 4 \times 1 \text{ m}^2) = 0.00990$$

$$F_{1i} = D_i / (D_i^2 + 4L^2) = 0.15^2 \text{ m}^2 / (0.15^2 \text{ m}^2 + 4 \times 1 \text{ m}^2) = 0.00559.$$

The net radiation exchange is then

$$q_{12} = \frac{\pi (0.03 \text{ m})^2}{4} \times 0.00431 \times 5.67 \times 10^{-8} \frac{\text{W}}{\text{m}^2 \cdot \text{K}^4} (500^4 - 1000^4) \text{ K}^4 = -0.162 \text{ W}.$$

**COMMENTS:**  $F_{12}$  can be approximated using solid angle concepts if  $D_o \ll L$ . That is, the view factor for  $A_1$  to  $A_o$  (whose diameter is  $D_o$ ) is

$$F_{1o} \approx \frac{\omega_{o-1}}{\pi} = \frac{A_o / L^2}{\pi} = \frac{\pi D_o^2}{4\pi L^2} = \frac{D_o^2}{4L^2}.$$

Numerically,  $F_{1o} = 0.0100$  and it follows  $F_{1i} \approx D_i^2 / 4L^2 = 0.00563$ . This gives  $F_{12} = 0.00437$ . An analytical expression can be obtained from Example 13.1 by replacing the lower limit of integration by  $D_i/2$ , giving

$$F_{12} = L^2 \left[ -1 / (D_o^2 / 4 + L^2) + 1 / (D_i^2 / 4 + L^2) \right] = 0.00431.$$

### PROBLEM 13.31

**KNOWN:** Two black, plane discs, one being solid, the other ring-shaped.

**FIND:** Net radiative heat exchange between the two surfaces.

**SCHEMATIC:**

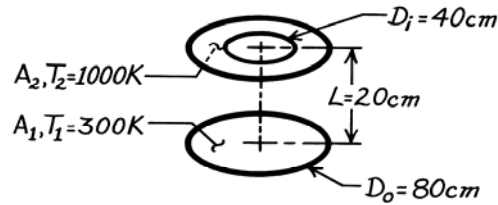

**ASSUMPTIONS:** (1) Discs are parallel and coaxial, (2) Discs are black, diffuse surfaces, (3) Convection effects are not being considered.

**ANALYSIS:** From Eq. 13.13

$$q_{12} = A_1 F_{12} \sigma (T_1^4 - T_2^4)$$

The view factor  $F_{12}$  can be determined from Fig. 13.5 after some manipulation. Define these two hypothetical surfaces;

$$A_3 = \frac{\pi D_o^2}{4}, \text{ located co-planar with } A_2, \text{ but a solid surface}$$

$$A_4 = \frac{\pi D_i^2}{4}, \text{ located co-planar with } A_2, \text{ representing the missing center.}$$

From view factor relations and Fig. 13.5, it follows that

$$F_{12} = F_{13} - F_{14} = 0.62 - 0.20 = 0.42$$

$$F_{14}: \quad \frac{r_j}{L} = \frac{40/2}{20} = 1, \quad \frac{L}{r_i} = \frac{20}{80/2} = 0.5, \quad F_{14} = 0.20$$

$$F_{13}: \quad \frac{r_j}{L} = \frac{80/2}{20} = 2, \quad \frac{L}{r_i} = \frac{20}{80/2} = 0.5, \quad F_{13} = 0.62.$$

Hence

$$q_{12} = \left( \pi 0.80^2 / 4 \right) \text{m}^2 \times 0.42 \times 5.67 \times 10^{-8} \text{W/m}^2 \cdot \text{K}^4 \left( 300^4 - 1000^4 \right) \text{K}^4$$

$$q_{12} = -11.87 \text{ kW.} \quad \leftarrow$$

Assuming negligible radiation exchange with the surroundings, the negative sign implies that  $q_1 = -11.87 \text{ kW}$  and  $q_2 = +11.87 \text{ kW}$ .

### PROBLEM 13.32

**KNOWN:** Radiometer viewing a small target area (1),  $A_1$ , with a solid angle  $\omega = 0.0008$  sr. Target has an area  $A_1 = 0.004 \text{ m}^2$  and is diffuse, gray with emissivity  $\varepsilon = 0.8$ . The target is heated by a ring-shaped disc heater (2) which is black and operates at  $T_2 = 1000 \text{ K}$ .

**FIND:** (a) Expression for the radiant power leaving the target which is collected by the radiometer in terms of the target radiosity,  $J_1$ , and relevant geometric parameters; (b) Expression for the target radiosity in terms of its irradiation, emissive power and appropriate radiative properties; (c) Expression for the irradiation on the target,  $G_1$ , due to emission from the heater in terms of the heater emissive power, the heater area and an appropriate view factor; numerically evaluate  $G_1$ ; and (d) Determine the radiant power collected by the radiometer using the foregoing expressions and results.

**SCHEMATIC:**

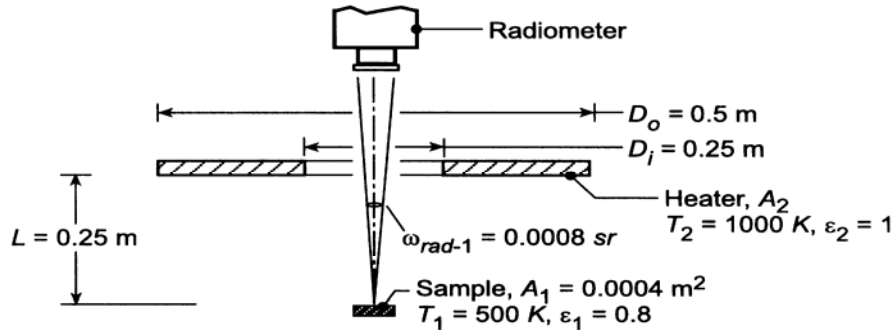

**ASSUMPTIONS:** (1) Target is diffuse, gray, (2) Target area is small compared to the square of the separation distance between the sample and the radiometer, and (3) Negligible irradiation from the surroundings onto the target area.

**ANALYSIS:** (a) From Eq. 12.27 with  $I_1 = I_{1,e+r} = J_1/\pi$ , the radiant power leaving the target collected by the radiometer is, from Eq. 12.11

$$q_{1 \rightarrow \text{rad}} = \frac{J_1}{\pi} A_1 \cos \theta_1 \omega_{\text{rad}-1} \quad < \quad (1)$$

where  $\theta_1 = 0^\circ$  and  $\omega_{\text{rad}-1}$  is the solid angle the radiometer subtends with respect to the target area.

(b) From Eq. 12.4, the radiosity is the sum of the emissive power plus the reflected irradiation.

$$J_1 = E_1 + \rho G_1 = \varepsilon E_{b,1} + (1 - \varepsilon) G_1 \quad < \quad (2)$$

where  $E_{b1} = \sigma T_1^4$  and  $\rho = 1 - \varepsilon$  since the target is diffuse, gray ( $\alpha = \varepsilon$ ).

(c) The irradiation onto  $G_1$  due to emission from the heater area  $A_2$  is

$$G_1 = \frac{q_{2 \rightarrow 1}}{A_1}$$

where  $q_{2 \rightarrow 1}$  is the radiant power leaving  $A_2$  which is intercepted by  $A_1$  and can be written as

$$q_{2 \rightarrow 1} = A_2 F_{21} E_{b2} \quad (3)$$

where  $E_{b2} = \sigma T_2^4$ .  $F_{21}$  is the fraction of radiant power leaving  $A_2$  which is intercepted by  $A_1$ . The view factor  $F_{12}$  can be written as

Continued ...

### PROBLEM 13.32 (Cont.)

$$F_{12} = F_{1-o} - F_{1-i} \qquad F_{12} = 0.5 - 0.2 = 0.3$$

where from Eq. 13.8,

$$F_{1-o} = \frac{D_o^2}{D_o^2 + 4L^2} = \frac{0.5^2}{0.5^2 + 4(0.25)^2} = 0.5 \qquad (3)$$

$$F_{1-i} = \frac{D_i^2}{D_i^2 + 4L^2} = \frac{0.25^2}{0.25^2 + 4(0.25)^2} = 0.2$$

and from the reciprocity rule,

$$F_{21} = \frac{A_1 F_{12}}{A_2} = \frac{0.0004 \text{ m}^2 \times 0.3}{\pi/4 (0.5^2 - 0.25^2) \text{ m}^2} = 0.000815$$

Substituting numerical values into Eq. (3), find

$$G_1 = \frac{\pi/4 (0.5^2 - 0.25^2) \text{ m}^2 \times 0.000815 \times 5.67 \times 10^{-8} \text{ W/m}^2 \cdot \text{K}^4 (1000 \text{ K})^4}{0.0004 \text{ m}^2}$$

$$G_1 = 17,013 \text{ W/m}^2 \qquad <$$

(d) Substituting numerical values into Eq. (1), the radiant power leaving the target collected by the radiometer is

$$q_{1 \rightarrow \text{rad}} = (6238 \text{ W/m}^2 / \pi \text{ sr}) \times 0.0004 \text{ m}^2 \times 1 \times 0.0008 \text{ sr} = 635 \mu\text{W} \qquad <$$

where the radiosity,  $J_1$ , is evaluated using Eq. (2) and  $G_1$ .

$$J_1 = 0.8 \times 5.67 \times 10^{-8} \text{ W/m}^2 \cdot \text{K}^4 \times (500 \text{ K})^4 + (1 - 0.8) \times 17,013 \text{ W/m}^2$$

$$J_1 = (2835 + 3403) \text{ W/m}^2 = 6238 \text{ W/m}^2 \qquad <$$

**COMMENTS:** (1) Note that the emitted and reflected irradiation components of the radiosity,  $J_1$ , are of the same magnitude.

(2) Suppose the surroundings were at room temperature,  $T_{\text{sur}} = 300 \text{ K}$ . Would the reflected irradiation due to the surroundings contribute significantly to the radiant power collected by the radiometer? Justify your conclusion.

### PROBLEM 13.33

**KNOWN:** Thin-walled, black conical cavity with opening  $D = 10$  mm and depth of  $L = 12$  mm that is well insulated from its surroundings. Temperature of meter housing and surroundings is  $25.0^\circ\text{C}$ .

**FIND:** Radiant flux of laser beam,  $G_o$  ( $\text{W}/\text{m}^2$ ), incident on the cavity when the fine-wire thermocouple indicates a temperature rise of  $10.1^\circ\text{C}$ .

**SCHEMATIC:**

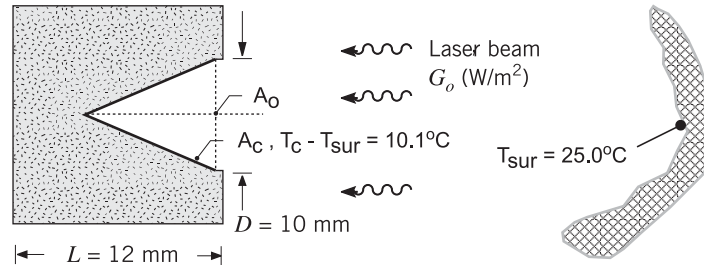

**ASSUMPTIONS:** (1) Cavity surface is black and perfectly insulated from its mounting material in the meter, (2) Negligible convection heat transfer from the cavity surface, and (3) Surroundings are large, isothermal.

**ANALYSIS:** Perform an energy balance on the walls of the cavity considering absorption of the laser irradiation, absorption from the surroundings and emission.

$$\dot{E}_{\text{in}} - \dot{E}_{\text{out}} = 0$$

$$A_o G_o + A_o G_{\text{sur}} - A_o E_b(T_c) = 0$$

where  $A_o = \pi D^2/4$  represents the opening of the cavity. All of the radiation entering or leaving the cavity passes through this hypothetical surface. Hence, we can treat the cavity as a black disk at  $T_c$ . Since  $G_{\text{sur}} = E_b(T_{\text{sur}})$ , and  $E_b = \sigma T^4$  with  $\sigma = 5.67 \times 10^{-8} \text{ W}/\text{m}^2 \cdot \text{K}^4$ , the energy balance has the form

$$G_o + \sigma(25.0 + 273)^4 \text{ K}^4 - \sigma(25.0 + 10.1 + 273)^4 \text{ K}^4 = 0$$

$$G_o = 63.8 \text{ W}/\text{m}^2$$

<



### PROBLEM 13.34

**KNOWN:** Electrically heated sample maintained at  $T_s = 500$  K with diffuse, spectrally selective coating. Sample is irradiated by a furnace located coaxial to the sample at a prescribed distance. Furnace has isothermal walls at  $T_f = 3000$  K with  $\epsilon_f = 0.7$  and an aperture of 25 mm diameter. Sample experiences convection with ambient air at  $T_\infty = 300$  K and  $h = 20$  W/m<sup>2</sup>·K. The surroundings of the sample are large with a uniform temperature  $T_{sur} = 300$  K. A radiation detector sensitive to only power in the spectral region 3 to 5  $\mu$ m is positioned at a prescribed location relative to the sample.

**FIND:** (a) Electrical power,  $P_e$ , required to maintain the sample at  $T_s = 500$  K, and (b) Radiant power incident on the detector within the spectral region 3 to 5  $\mu$ m considering both emission and reflected irradiation from the sample.

**SCHEMATIC:**

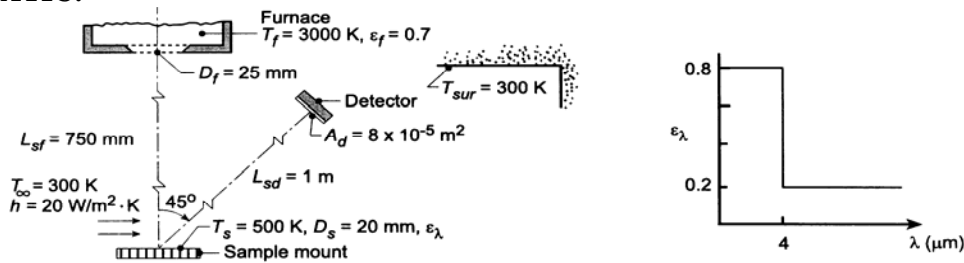

**ASSUMPTIONS:** (1) Steady-state condition, (2) Furnace is large, isothermal enclosure with small aperture and radiates as a blackbody, (3) Sample coating is diffuse, spectrally selective, (4) Sample and detector areas are small compared to their separation distance squared, (5) Surroundings are large, isothermal.

**ANALYSIS:** (a) Perform an energy balance on the sample mount, which experiences electrical power dissipation, convection with ambient air, absorbed irradiation from the furnace, absorbed irradiation from the surroundings and emission,

$$\dot{E}_{in} - \dot{E}_{out} = 0$$

$$P_e + [-h(T_s - T_\infty) + \alpha_f G_f + \alpha_{sur} G_{sur} - \epsilon E_b(T_s)] A_s = 0 \quad (1)$$

where  $E_b(T_s) = \sigma T_s^4$  and  $A_s = \pi D_s^2 / 4$ .

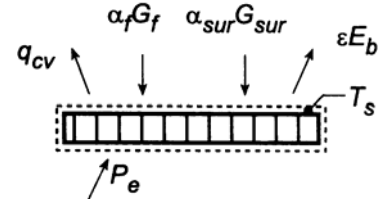

*Irradiations on the sample:* The irradiation from the furnace aperture onto the sample can be written as

$$G_f = \frac{q_{f \rightarrow s}}{A_s} = \frac{A_f F_{fs} E_{b,f}}{A_s} = \frac{A_f F_{fs} \sigma T_f^4}{A_s} \quad (2)$$

where  $A_f = \pi D_f^2 / 4$  and  $A_s = \pi D_s^2 / 4$ . The view factor between the furnace aperture and sample follows from the relation for coaxial parallel disks, Table 13.2,

$$R_f = r_f / L_{sf} = 0.0125 \text{ m} / 0.750 \text{ m} = 0.01667$$

$$R_s = r_s / L_{sf} = 0.0100 \text{ m} / 0.750 \text{ m} = 0.01333$$

$$S = 1 + \frac{1 + R_s^2}{R_f^2} = 1 + \frac{1 + 0.01333^2}{0.01667^2} = 3600.2$$

Continued ...

**PROBLEM 13.34 (Cont.)**

$$F_{\text{sf}} = 0.5 \left\{ S - \left[ S^2 - 4(r_s / r_f)^2 \right]^{1/2} \right\} = 0.5 \left\{ 3600 - \left[ 3600^2 - 4(0.05 / 0.0625)^2 \right]^{1/2} \right\} = 0.000178$$

Hence the irradiation from the furnace is

$$G_f = \frac{\pi (0.025 \text{ m})^2 / 4 \times 0.000178 \times 5.67 \times 10^{-8} \text{ W / m}^2 \cdot \text{K}^4 (3000 \text{ K})^4}{\pi (0.020^2 \text{ m}^2 / 4)} = 1277 \text{ W / m}^2$$

The irradiation from the surroundings which are large compared to the sample is

$$G_{\text{sur}} = \sigma T_{\text{sur}}^4 = 5.67 \times 10^{-8} \text{ W / m}^2 \cdot \text{K} (300 \text{ K})^4 = 459 \text{ W / m}^2$$

*Emissivity of the Sample:* The total hemispherical emissivity in terms of the spectral distribution can be written following Eq. 12.43 and Eq. 12.34,

$$\varepsilon = \int_0^\infty \varepsilon_\lambda E_{\lambda, \text{b}}(T_s) d\lambda / \sigma T^4 = \varepsilon_1 F_{(0-\lambda_1 T_s)} + \varepsilon_2 \left[ 1 - F_{(0-\lambda_1 T_s)} \right]$$

$$\varepsilon = 0.8 \times 0.066728 + 0.2 [1 - 0.066728] = 0.240$$

where, from Table 12.1, with  $\lambda_1 T_s = 4 \mu\text{m} \times 500 \text{ K} = 2000 \mu\text{m} \cdot \text{K}$ ,  $F_{(0-\lambda T)} = 0.066728$ .

*Absorptivity of the Sample:* The total hemispherical absorptivity due to irradiation from the furnace follows from Eq. 12.52 and Eq. 12.34,

$$\alpha_f = \varepsilon_1 F_{(0-\lambda_1 T_f)} + \varepsilon_2 \left[ 1 - F_{(0-\lambda_1 T_f)} \right] = 0.8 \times 0.945098 + 0.2 [1 - 0.945098] = 0.767$$

where, from Table 12.1, with  $\lambda_1 T_f = 4 \mu\text{m} \times 3000 \text{ K} = 12,000 \mu\text{m} \cdot \text{K}$ ,  $F_{(0-\lambda T)} = 0.945098$ . The total hemispherical absorptivity due to irradiation from the surroundings is

$$\alpha_{\text{sur}} = \varepsilon_1 F_{(0-\lambda_1 T_{\text{sur}})} + \varepsilon_2 \left[ 1 - F_{(0-\lambda_1 T_{\text{sur}})} \right] = 0.8 \times 0.00234 + 0.2 [1 - 0.00234] = 0.201$$

where, from Table 12.1, with  $\lambda_1 T_{\text{sur}} = 4 \mu\text{m} \times 300 \text{ K} = 1200 \mu\text{m} \cdot \text{K}$ ,  $F_{(0-\lambda T)} = 0.00234$ .

*Evaluating the Energy Balance:* Substituting numerical values into Eq. (1),

$$P_e = \left[ +20 \text{ W / m}^2 \cdot \text{K} (500 - 300) \text{ K} - 0.767 \times 1277 \text{ W / m}^2 \right.$$

$$\left. - 0.201 \times 459 \text{ W / m}^2 + 0.240 \times 5.67 \times 10^{-8} \text{ W / m}^2 \cdot \text{K}^4 (500 \text{ K})^4 \right] \times 4 / \left( \pi \times (0.02 \text{ m})^2 \right)$$

$$P_e = 1.256 \text{ W} - 0.308 \text{ W} - 0.029 \text{ W} + 0.267 \text{ W} = 1.19 \text{ W} \quad <$$

(b) The radiant power leaving the sample which is incident on the detector and within the spectral region,  $\Delta\lambda = 3$  to  $5 \mu\text{m}$ , follows from Eq. 12.11 with Eq. 12.34,

$$q_{\text{s-d}, \Delta\lambda} = \left[ E_{\text{s}, \Delta\lambda} + G_{\text{f}, \text{ref}, \Delta\lambda} + G_{\text{sur}, \text{ref}, \Delta\lambda} \right] (1/\pi) A_s \cos \theta_s \cdot A_d \cos \theta_d / L_{\text{sd}}^2$$

where  $\theta_s = 45^\circ$  and  $\theta_d = 0^\circ$ . The *emitted* component is

$$E_{\text{s}, \Delta\lambda} = \int_3^{5 \mu\text{m}} \varepsilon_\lambda E_{\lambda, \text{b}}(T_s)$$

$$E_{\text{s}, \Delta\lambda} = \left\{ \varepsilon_1 \left[ F_{(0-4 \mu\text{m}, T_s)} - F_{(0-3 \mu\text{m}, T_s)} \right] + \varepsilon_2 \left[ F_{(0-5 \mu\text{m}, T_s)} - F_{(0-4 \mu\text{m}, T_s)} \right] \right\} \sigma T_s^4$$

Continued ...

**PROBLEM 13.34 (Cont.)**

$$E_{s,\Delta\lambda} = \{0.8[0.066728 - 0.013754] + 0.2[0.16169 - 0.066728]\} \sigma (500\text{K})^4 = 217.5 \text{ W/m}^2$$

where, from Table 12.1,  $F_{(0-3\mu\text{m}, T_s)} = 0.013754$  at  $\lambda T = 3\mu\text{m} \times 500 \text{ K} = 1500 \mu\text{m}\cdot\text{K}$ ;

$F_{(0-4\mu\text{m}, T_s)} = 0.066728$  at  $\lambda = 4\mu\text{m} \times 500 \text{ K} = 2000 \mu\text{m}\cdot\text{K}$ ; and  $F_{(0-5\mu\text{m}, T_s)} = 0.16169$  at  $\lambda T = 5\mu\text{m} \times 500 \text{ K} = 2500 \mu\text{m}\cdot\text{K}$ .

The *reflected irradiation from the furnace* component is

$$G_{f,\text{ref},\Delta\lambda} = \int_3^{5\mu\text{m}} (1 - \varepsilon_\lambda) G_{f,\lambda} d\lambda$$

where  $G_{f,\lambda} \approx E_{\lambda,b}(T_f)$ , using band emission factors,

$$G_{f,\text{ref},\Delta\lambda} = \left\{ (1 - \varepsilon_1) \left[ F_{(0-4\mu\text{m}, T_f)} - F_{(0-3\mu\text{m}, T_f)} \right] + (1 - \varepsilon_2) \left[ F_{(0-5\mu\text{m}, T_f)} - F_{(0-4\mu\text{m}, T_f)} \right] \right\} G_f$$

$$G_{f,\text{ref},\Delta\lambda} = \{0.2[0.9451 - 0.8900] + 0.8[0.9700 - 0.9451]\} 1277 \text{ W/m}^2 = 39.51 \text{ W/m}^2$$

where, from Table 12.1,  $F_{(0-3\mu\text{m}, T_f)} = 0.8900$  at  $\lambda T_f = 3\mu\text{m} \times 3000 \text{ K} = 9000 \mu\text{m}\cdot\text{K}$ ;

$F_{(0-4\mu\text{m}, T_f)} = 0.9451$  at  $\lambda T_f = 4\mu\text{m} \times 3000 \text{ K} = 12,000 \mu\text{m}\cdot\text{K}$ ; and,  $F_{(0-5\mu\text{m}, T_f)} = 0.9700$  at  $\lambda T_f = 5\mu\text{m} \times 3000 \text{ K} = 15,000 \mu\text{m}\cdot\text{K}$ .

The *reflected irradiation from the surroundings* component is

$$G_{\text{sur},\text{ref},\Delta\lambda} = \int_3^{5\mu\text{m}} (1 - \varepsilon_\lambda) G_{\text{ref},\lambda} d\lambda$$

where  $G_{\text{ref},\lambda} \approx E_\lambda(T_{\text{sur}})$ , using band emission factors,

$$G_{\text{sur},\text{ref},\Delta\lambda} = \left\{ (1 - \varepsilon_1) \left[ F_{(0-4\mu\text{m}, T_{\text{sur}})} - F_{(0-3\mu\text{m}, T_{\text{sur}})} \right] + (1 - \varepsilon_2) \left[ F_{(0-5\mu\text{m}, T_{\text{sur}})} - F_{(0-4\mu\text{m}, T_{\text{sur}})} \right] \right\} G_{\text{sur}}$$

$$G_{\text{sur},\text{ref},\Delta\lambda} = \{0.2[0.002134 - 0.0001685] - 0.8[0.013754 - 0.002134]\} 459 \text{ W/m}^2 = 4.44 \text{ W/m}^2$$

where, from Table 12.1,  $F_{(0-3\mu\text{m}, T_{\text{sur}})} = 0.0001685$  at  $\lambda T_{\text{sur}} = 3\mu\text{m} \times 300 \text{ K} = 900 \mu\text{m}\cdot\text{K}$ ;

$F_{(0-4\mu\text{m}, T_{\text{sur}})} = 0.002134$  at  $\lambda T_{\text{sur}} = 4\mu\text{m} \times 300 \text{ K} = 1200 \mu\text{m}\cdot\text{K}$ ; and  $F_{(0-5\mu\text{m}, T_{\text{sur}})} = 0.013754$  at

$\lambda T_{\text{sur}} = 5\mu\text{m} \times 300 \text{ K} = 1500 \mu\text{m}\cdot\text{K}$ . Returning to Eq. (3), find

$$q_{\text{sd},\Delta\lambda} = [217.5 + 39.51 + 4.44] \text{ W/m}^2 (1/\pi) \left[ \pi (0.020 \text{ m})^2 / 4 \right] \cos 45^\circ \times 8 \times 10^{-5} \text{ m}^2 \times \cos 0^\circ / (1 \text{ m})^2 = 1.48 \mu\text{W} <$$

**COMMENTS:** (1) Note that  $F_{fs}$  is small, since  $A_f, A_s \ll L_{sf}^2$ . As such, we could have evaluated  $q_{f \rightarrow s}$  using Eq. 12.6 and found

$$G_f = \frac{E_{b,f} / \pi A_f \left( A_s / L_{sf}^2 \right)}{A_s} = 1276 \text{ W/m}^2$$

(2) Recognize in the analysis for part (b), Eq. (3), the role of the band emission factors in calculating the fraction of total radiant power for the emitted and reflected irradiation components.

### PROBLEM 13.35

**KNOWN:** Water-cooled heat flux gage exposed to radiant source, convection process and surroundings.

**FIND:** (a) Net radiation exchange between heater and gage, (b) Net transfer of radiation to the gage per unit area of the gage, (c) Net heat transfer to the gage per unit area of gage, (d) Heat flux indicated by gage described in Problem 3.98.

**SCHEMATIC:**

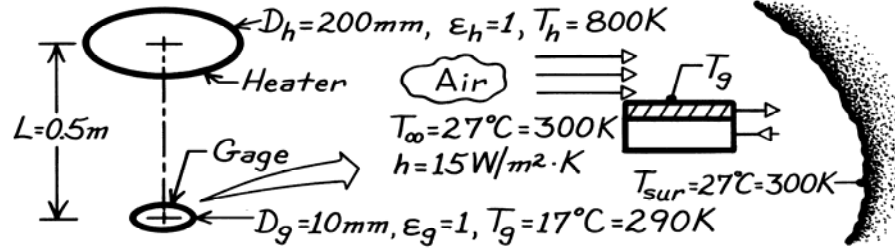

**ASSUMPTIONS:** (1) Heater and gage are parallel, coaxial discs having blackbody behavior, (2)  $A_g \ll A_h$ , (3) Surroundings are large compared to  $A_h$  and  $A_g$ .

**ANALYSIS:** (a) The net radiation exchange between the heater and the gage, both with blackbody behavior, is

$$q_{h-g} = A_h F_{hg} \sigma (T_h^4 - T_g^4) = A_g F_{gh} \sigma (T_h^4 - T_g^4).$$

Note the use of reciprocity, Eq. 13.3, for the view factors. From Eq. 13.8,

$$F_{gh} = D_h^2 / (4L^2 + D_h^2) = (0.2\text{m})^2 / (4 \times 0.5^2 \text{m}^2 + 0.2^2 \text{m}^2) = 0.0385.$$

$$q_{h-g} = (\pi 0.01^2 \text{m}^2 / 4) \times 0.0385 \times 5.67 \times 10^{-8} \text{W} / \text{m}^2 \cdot \text{K}^4 [800^4 - 290^4] \text{K}^4 = 69.0 \text{ mW}. \quad <$$

(b) The net radiation *to* the gage per unit area will involve exchange with the heater and the surroundings.

$$q''_{\text{net,rad}} = -q_g / A_g = q_{h-g} / A_g + q_{\text{sur-g}} / A_g.$$

The net exchange with the surroundings is

$$q_{\text{sur-g}} = A_{\text{sur}} F_{\text{sur-g}} \sigma (T_{\text{sur}}^4 - T_g^4) = A_g F_{g-\text{sur}} \sigma (T_{\text{sur}}^4 - T_g^4).$$

$$q''_{\text{net,rad}} = \frac{69.0 \times 10^{-3} \text{W}}{\pi (0.01 \text{m})^2 / 4} + (1 - 0.0385) 5.67 \times 10^{-8} \text{W} / \text{m}^2 \cdot \text{K}^4 (300^4 - 290^4) \text{K}^4 = 934.5 \text{ W} / \text{m}^2. \quad <$$

(c) The net heat transfer rate to the gage per unit area of the gage follows from the surface energy balance

$$q''_{\text{net,in}} = q''_{\text{net,rad}} + q''_{\text{conv}}$$

$$q''_{\text{net,in}} = 934.5 \text{ W} / \text{m}^2 + 15 \text{ W} / \text{m}^2 \cdot \text{K} (300 - 290) \text{K}$$

$$q''_{\text{net,in}} = 1085 \text{ W} / \text{m}^2. \quad <$$

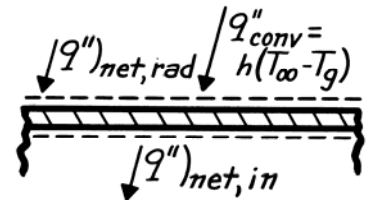

(d) The heat flux gage described in Problem 3.98 would experience a net heat flux to the surface of  $1085 \text{ W} / \text{m}^2$ . The irradiation to the gage from the heater is  $G_g = q_{h \rightarrow g} / A_g = F_{gh} \sigma T_h^4 = 894 \text{ W} / \text{m}^2$ . Since the gage responds to net heat flux, there would be a systematic error in sensing irradiation from the heater.

### PROBLEM 13.36

**KNOWN:** Long cylindrical heating element located a given distance above an insulated wall exposed to cool surroundings. Diameter and temperature of heating element. Surroundings temperature.

**FIND:** (a) Maximum temperature attained by wall. (b) Plot the wall temperature over the range  $-100 \text{ mm} \leq x \leq 100 \text{ mm}$ .

**SCHEMATIC:**

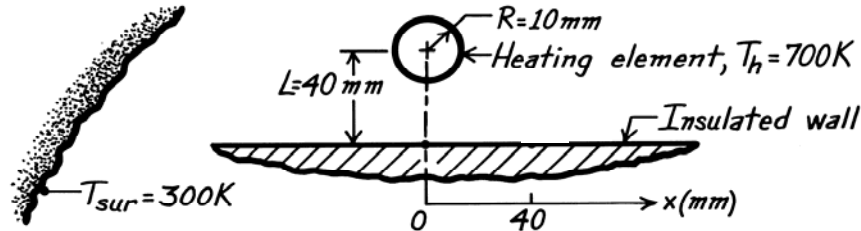

**ASSUMPTIONS:** (1) Steady-state conditions, (2) Insulated wall, (3) Negligible conduction in wall, (4) All surfaces are black.

**ANALYSIS:** (a) We begin with a general analysis for the temperature at any point  $x$ . Consider an elemental area  $dA_o$  at point  $x$ . Since the wall is insulated and conduction is negligible, the net radiation leaving  $dA_o$  is zero. From Eq. 13.14 (divided by  $A_i$ ),

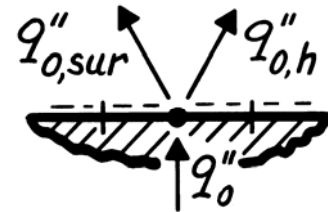

$$q''_o = q''_{o,h} + q''_{o,sur} = F_{o,h} \sigma (T_o^4 - T_h^4) + F_{o,sur} \sigma (T_o^4 - T_{sur}^4) = 0 \quad (1)$$

where  $F_{o,sur} = 1 - F_{o,h}$  and  $F_{o,h}$  can be found from the relation for a cylinder and parallel rectangle, Table 13.1, with  $s_2 = x$  and  $s_1 = s_2 + \delta$ , in the limit as  $\delta \rightarrow 0$ . From a Taylor series expansion,

$$\lim_{\delta \rightarrow 0} \tan^{-1} \left( \frac{s_2 + \delta}{L} \right) = \tan^{-1} \left( \frac{s_2}{L} \right) + \frac{\delta/L}{1 + (s_2/L)^2}$$

Thus,

$$F_{o,h} = \frac{r}{s_1 - s_2} \left[ \tan^{-1} \frac{s_1}{L} - \tan^{-1} \frac{s_2}{L} \right] = \frac{r}{\delta} \left[ \frac{\delta/L}{1 + (s_2/L)^2} \right] = \frac{r/L}{1 + (x/L)^2} \quad (2)$$

Rearranging Eq. (1) and substituting numerical values, find

$$T_o = \left[ F_{o,h} T_h^4 + (1 - F_{o,h}) T_{sur}^4 \right]^{1/4} \quad (3)$$

The maximum value of  $T_o$  will occur at  $x = 0$ , where  $F_{o,h} = r/L = 10/40 = 0.25$ . Thus,

$$T_{o,max} = \left[ 0.25(700 \text{ K})^4 + (1 - 0.25)(300 \text{ K})^4 \right]^{1/4} = 507 \text{ K} <$$

(b) Eq. (3) can be evaluated with Eq. (2) for  $F_{o,h}$ , over the range  $-100 \text{ mm} \leq x \leq 100 \text{ mm}$ . The results are shown below.

Continued...

### PROBLEM 13.36 (Cont.)

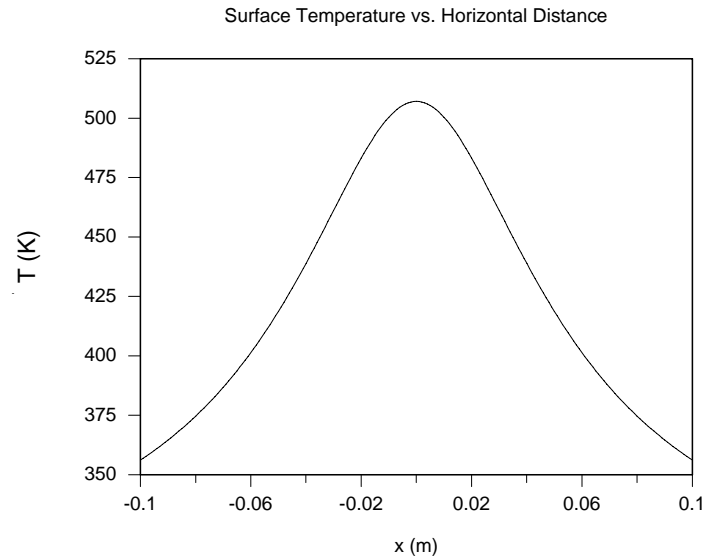

**COMMENTS:** (1) Note the importance of the assumptions that the wall is insulated and conduction is negligible. (2) In calculating  $F_{o,h}$  we are finding the view factor for a small area or point. As an alternative to using a Taylor series expansion, the value can be found by evaluating the view factor from the equation in Table 13.1 for progressively smaller values of  $s_1 - s_2$  until the value converges.

### PROBLEM 13.37

**KNOWN:** Diameter and pitch of in-line tubes occupying evacuated space between parallel plates of prescribed temperature. Temperature and flowrate  $\dot{m}$  of water through the tubes.

**FIND:** (a) Tube surface temperature  $T_s$  for  $\dot{m} = 0.20$  kg/s, (b) Effect of  $\dot{m}$  on  $T_s$ .

**SCHEMATIC:**

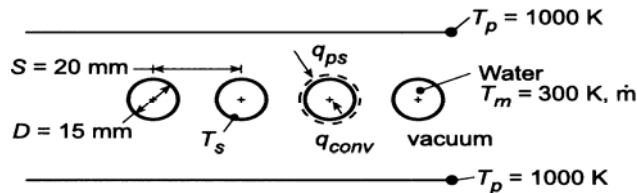

**ASSUMPTIONS:** (1) Surfaces behave as blackbodies, (2) Negligible tube wall conduction resistance, (3) Fully-developed tube flow.

**PROPERTIES:** Table A-6, water ( $T_m = 300$  K):  $\mu = 855 \times 10^{-6}$  N·s/m<sup>2</sup>,  $k = 0.613$  W/m·K,  $Pr = 5.83$ .

**ANALYSIS:** (a) Performing an energy balance on a single tube, it follows that  $q_{ps} = q_{conv}$ , or

$$A_p F_{ps} \sigma (T_p^4 - T_s^4) = h A_s (T_s - T_m)$$

From Table 13.1 and  $D/S = 0.75$ , the view factor is

$$F_{ps} = 1 - \left[ 1 - \left( \frac{D}{S} \right)^2 \right]^{1/2} + \left( \frac{D}{S} \right) \tan^{-1} \left( \frac{S^2 - D^2}{D^2} \right)^{1/2} = 0.881$$

With  $Re_D = 4\dot{m} / \pi D \mu = 4(0.20 \text{ kg/s}) / \pi(0.015 \text{ m}) 855 \times 10^{-6} \text{ N} \cdot \text{s} / \text{m}^2 = 19,856$ , fully-developed turbulent flow may be assumed, in which case Eq. 8.60 yields

$$h = \frac{k}{D} \left( 0.023 Re_D^{4/5} Pr^{0.4} \right) = \frac{0.613 \text{ W/m} \cdot \text{K}}{0.015 \text{ m}} (0.023)(19,856)^{4/5} (5.83)^{0.4} = 5220 \text{ W/m}^2 \cdot \text{K}$$

Hence, with  $(A_p/A_s) = 2S/\pi D = 0.849$ ,

$$T_s - T_m = \frac{F_{ps} \sigma}{h} \frac{A_p}{A_s} (T_p^4 - T_s^4) = \frac{0.881 \times 5.67 \times 10^{-8} \text{ W/m}^2 \cdot \text{K}^4}{5220 \text{ W/m}^2 \cdot \text{K}} (0.849) (T_p^4 - T_s^4)$$

With  $T_m = 300$  K and  $T_p = 1000$  K, a trial-and-error solution yields

$$T_s = 308 \text{ K}$$

(b) Using the *Correlations and Radiation* Toolpads of *IHT* to evaluate the convection coefficient and view factor, respectively, the following results were obtained.

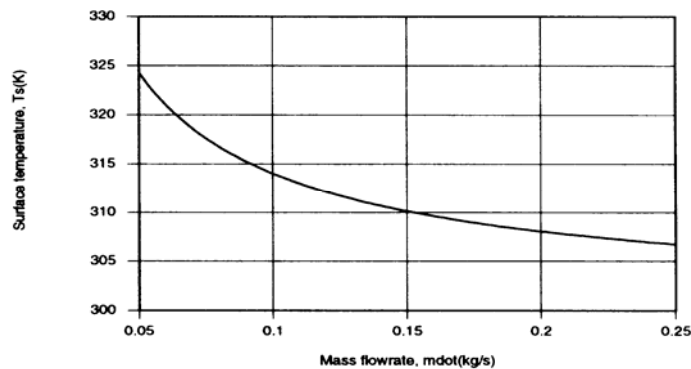

The decrease in  $T_s$  with increasing  $\dot{m}$  is due to an increase in  $h$  and hence a reduction in the convection resistance.

**COMMENTS:** Due to the large value of  $h$ ,  $T_s \ll T_p$ .

### PROBLEM 13.38

**KNOWN:** Insulated wall exposed to a row of regularly spaced cylindrical heating elements.

**FIND:** Required operating temperature of the heating elements for the prescribed conditions.

**SCHEMATIC:**

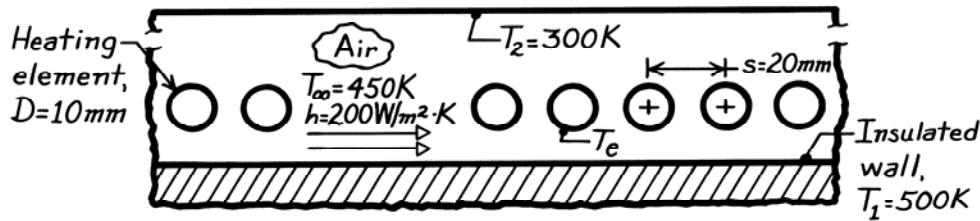

**ASSUMPTIONS:** (1) Upper and lower walls are isothermal and infinite, (2) Lower wall is insulated, (3) All surfaces are black, (4) Steady-state conditions.

**ANALYSIS:** Perform an energy balance on the insulated wall considering convection and radiation.

$$\dot{E}_{in}'' - \dot{E}_{out}'' = -q_1'' - q_{conv}'' = 0$$

where  $q_1''$  is the net radiation leaving the insulated wall per unit area. We know that

$$q_1'' = q_{1e}'' + q_{12}'' = F_{1e}\sigma(T_1^4 - T_e^4) + F_{12}\sigma(T_1^4 - T_2^4)$$

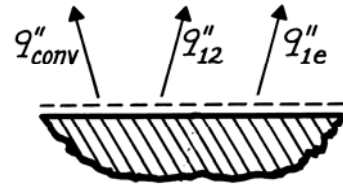

where  $F_{12} = 1 - F_{1e}$ . Using Newton's law of cooling for  $q_{conv}''$  solve for  $T_e$ .

$$T_e^4 = \left[ T_1^4 + \frac{(1 - F_{1e})}{F_{1e}} (T_1^4 - T_2^4) \right] + \frac{h}{\sigma F_{1e}} (T_1 - T_\infty).$$

The view factor between the insulated wall and the tube row follows from the relation for an infinite plane and row of cylinders, Table 13.1,

$$F_{1e} = 1 - \left[ 1 - \left( \frac{D}{S} \right)^2 \right]^{1/2} + \left( \frac{D}{S} \right) \tan^{-1} \left( \frac{s^2 - D^2}{D^2} \right)^{1/2}$$

$$F_{1e} = 1 - \left[ 1 - \left( \frac{10}{20} \right)^2 \right]^{1/2} + \left( \frac{10}{20} \right) \tan^{-1} \left( \frac{20^2 - 10^2}{10^2} \right)^{1/2} = 0.658.$$

Substituting numerical values, find

$$T_e^4 = \left[ (500 \text{ K})^4 + \frac{1 - 0.658}{0.658} (500^4 - 300^4) \text{ K}^4 \right] + \frac{200 \text{ W/m}^2 \cdot \text{K}}{5.67 \times 10^{-8} \text{ W/m}^2 \cdot \text{K}^4} \times \frac{1}{0.658} (500 - 450) \text{ K}$$

$$T_e = 774 \text{ K.} \quad <$$

**COMMENTS:** Always express temperatures in kelvins when considering convection and radiation terms in an energy balance. Why is  $F_{1e}$  independent of the distance between the row of tubes and the wall?



### PROBLEM 13.39

**KNOWN:** Surface radiative properties, diameter and initial temperature of a copper rod placed in an evacuated oven of prescribed surface temperature.

**FIND:** (a) Initial heating rate, (b) Time  $t_h$  required to heat rod to 1000 K, (c) Effect of convection on heating time.

**SCHEMATIC:**

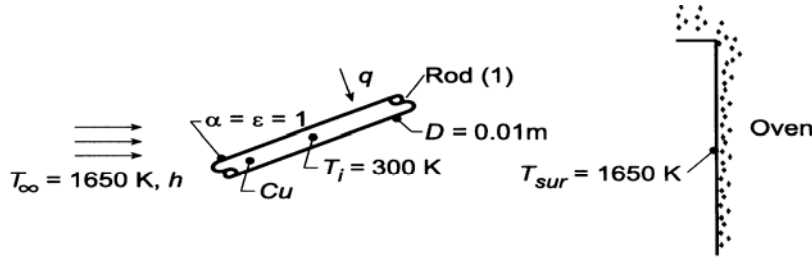

**ASSUMPTIONS:** (1) Copper may be treated as a lumped capacitance, (b) Radiation exchange between rod and oven may be approximated as blackbody exchange.

**PROPERTIES:** Table A-1, Copper (300 K):  $\rho = 8933 \text{ kg/m}^3$ ,  $c_p = 385 \text{ J/kg}\cdot\text{K}$ ,  $k = 401 \text{ W/m}\cdot\text{K}$ .

**ANALYSIS:** (a) Performing an energy balance on a unit length of the rod,  $\dot{E}_{\text{in}} = \dot{E}_{\text{st}}$ , or

$$q = Mc_p \frac{dT}{dt} = \rho \left( \frac{\pi D^2}{4} \times 1 \right) c_p \frac{dT}{dt}$$

Neglecting convection,  $q = q_{\text{rad}} = A_2 F_{21} \sigma (T_{\text{sur}}^4 - T^4) = A_1 F_{12} \sigma (T_{\text{sur}}^4 - T^4)$ , where  $A_1 = \pi D \times 1$  and  $F_{12} = 1$ . It follows that

$$\frac{dT}{dt} = \frac{\sigma \pi D (T_{\text{sur}}^4 - T^4)}{\rho (\pi D^2 / 4) c_p} = \frac{4\sigma (T_{\text{sur}}^4 - T^4)}{\rho D c_p} \quad (1)$$

$$\left. \frac{dT}{dt} \right|_i = \frac{4 \left[ (1650 \text{ K})^4 - (300 \text{ K})^4 \right] 5.67 \times 10^{-8} \text{ W/m}^2 \cdot \text{K}^4}{8933 \text{ kg/m}^3 (0.01 \text{ m}) 385 \text{ J/kg}\cdot\text{K}} = 48.8 \text{ K/s.} \quad <$$

(b) Using the *IHT Lumped Capacitance Model* to numerically integrate Eq. (2), we obtain

$$t_s = 15.0 \text{ s} \quad <$$

(c) With convection,  $q = q_{\text{rad}} + q_{\text{conv}} = A_1 F_{12} \sigma (T_{\text{sur}}^4 - T^4) + hA_1 (T_{\infty} - T)$ , and the energy balance becomes

$$\frac{dT}{dt} = \frac{4\sigma (T_{\text{sur}}^4 - T^4)}{\rho D c_p} + \frac{4h(T_{\infty} - T)}{\rho D c_p}$$

Performing the numerical integration for the three values of  $h$ , we obtain

$h \text{ (W/m}^2\cdot\text{K)}$ :	10	100	500
$t_h \text{ (s)}$ :	14.6	12.0	6.8

**COMMENTS:** With an initial value of  $h_{\text{rad},i} = \sigma (T_{\text{sur}}^4 - T^4) / (T_{\text{sur}} - T) = 311 \text{ W/m}^2\cdot\text{K}$ ,  $Bi = h_{\text{rad}} (D/4) / k = 0.002$  and the lumped capacitance assumption is justified for parts (a) and (b). With  $h = 500 \text{ W/m}^2\cdot\text{K}$  and  $h + h_{\text{r},i} = 811 \text{ W/m}\cdot\text{K}$  in part (c),  $Bi = 0.005$  and the lumped capacitance approximation is also valid.

### PROBLEM 13.40

**KNOWN:** Long, inclined black surfaces maintained at prescribed temperatures.

**FIND:** (a) Net radiation exchange between the two surfaces per unit length, (b) Net radiation transfer to surface  $A_2$  with black, insulated surface positioned as shown below; determine temperature of this surface.

**SCHEMATIC:**

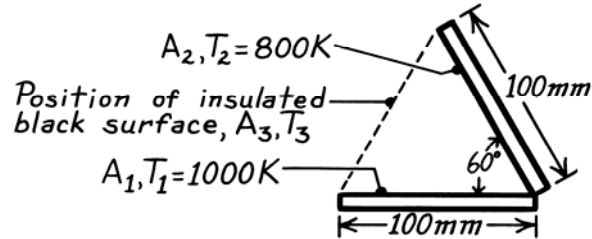

**ASSUMPTIONS:** (1) Surfaces behave as blackbodies, (2) Surfaces are very long in direction normal to page.

**ANALYSIS:** (a) The net radiation exchange between two black surfaces is

$$q_{12} = A_1 F_{12} \sigma (T_1^4 - T_2^4)$$

Noting that  $A_1 = \text{width} \times \text{length}$  ( $\ell$ ) and that from symmetry,  $F_{12} = 0.5$ , find

$$q'_{12} = \frac{q_{12}}{\ell} = 0.1 \text{ m} \times 0.5 \times 5.67 \times 10^{-8} \text{ W/m}^2 \cdot \text{K}^4 (1000^4 - 800^4) \text{ K}^4 = 1680 \text{ W/m.} \quad <$$

(b) From Eq. 13.14,

$$q'_3 = \frac{q_3}{\ell} = \frac{A_3}{\ell} F_{31} \sigma (T_3^4 - T_1^4) + \frac{A_3}{\ell} F_{32} \sigma (T_3^4 - T_2^4) = 0$$

Since  $F_{31} = F_{32}$ ,  $T_3 = \left[ \frac{(T_1^4 + T_2^4)}{2} \right]^{1/4} = \left[ \frac{(1000^4 + 800^4)}{2} \right]^{1/4} \text{ K} = 916 \text{ K.} \quad <$

Also from Eq. 13.14,

$$q'_2 = \frac{q_2}{\ell} = \frac{A_2}{\ell} F_{21} \sigma (T_2^4 - T_1^4) + \frac{A_2}{\ell} F_{23} \sigma (T_2^4 - T_3^4) \quad <$$

$$= 0.1 \times 0.5 \times 5.67 \times 10^{-8} \text{ W/m}^2 \cdot \text{K}^4 \times (2 \times 800^4 - 1000^4 - 916^4) \text{ K}^4 = -2508 \text{ W/m}$$

### PROBLEM 13.41

**KNOWN:** Position of long cylindrical-shaped product conveyed in an oven with non-uniform wall temperatures. Product diameter, temperature of surroundings and panel heaters.

**FIND:** (a) Radiation incident upon the product, per unit length at product locations  $x = 0.5$  m and  $x = 1.0$  m for  $\alpha = 0$ , (b) Radiation incident upon the product, per unit length, at product locations of  $x = 0.5$  m and  $x = 1.0$  m for  $\alpha = \pi/15$ .

**SCHEMATIC:**

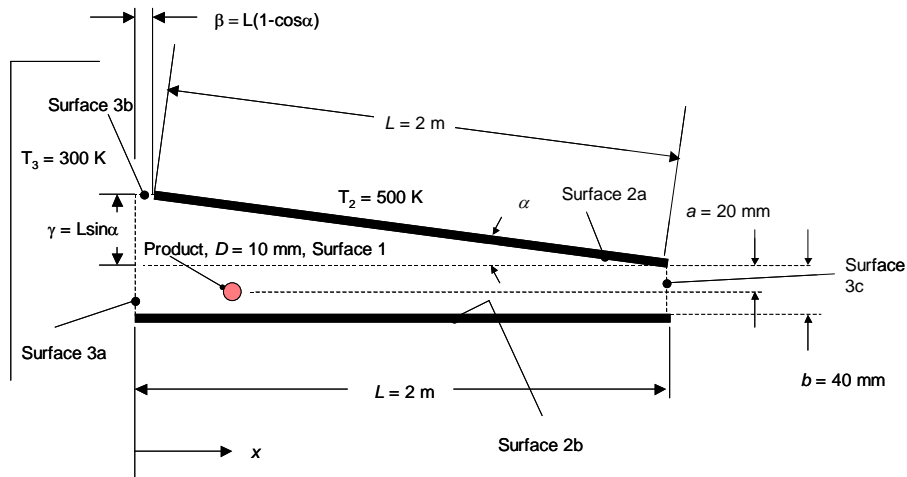

**ASSUMPTIONS:** (1) Two-dimensional system, (2) Steady-state conditions, (3) Blackbody behavior, (4) Large surroundings.

**ANALYSIS:**

Consider the cylinder and parallel rectangle arrangement of Table 13.1. We note that

$$F_{ij} = \frac{r}{s_1 - s_2} \left[ \tan^{-1} \frac{s_1}{L} - \tan^{-1} \frac{s_2}{L} \right]$$

and by reciprocity

$$F_{ji} = \frac{A_i F_{ij}}{A_j} = \frac{(s_1 - s_2) F_{ij}}{2\pi r}$$

Therefore,

$$F_{ji} = \frac{1}{2\pi} \left[ \tan^{-1} \frac{s_1}{L} + \tan^{-1} \frac{s_2}{L} \right] \quad (1)$$

Continued...

**PROBLEM 13.41 (Cont.)**

(a) For  $\alpha = 0$ ,

$$F_{13a} = \frac{1}{2\pi} \left[ \tan^{-1} \left( \frac{a}{x} \right) - \tan^{-1} \left( \frac{-(b-a)}{x} \right) \right]$$

where  $s_1 = a$  and  $s_2 = -(b - a)$ . For  $x = 0.5$  m,

$$F_{13a} = \frac{1}{2\pi} \left[ \tan^{-1} \left( \frac{0.02}{0.5} \right) - \tan^{-1} \left( \frac{-(0.04 - 0.02)}{0.5} \right) \right] = 0.0127$$

For  $x = 1.0$  m,

$$F_{13a} = \frac{1}{2\pi} \left[ \tan^{-1} \left( \frac{0.02}{1.0} \right) - \tan^{-1} \left( \frac{-(0.04 - 0.02)}{1.0} \right) \right] = 0.0064$$

Since  $A_{3b} = 0$  for  $\alpha = 0$ ,  $F_{13b} = 0$ .

For  $F_{13c}$  we note that  $s_1 = a$  and  $s_2 = -(b - a)$ . Therefore,

$$F_{13c} = \frac{1}{2\pi} \left[ \tan^{-1} \left( \frac{a}{L-x} \right) - \tan^{-1} \left( \frac{-(b-a)}{L-x} \right) \right]$$

For  $x = 0.5$  m,

$$F_{13c} = \frac{1}{2\pi} \left[ \tan^{-1} \left( \frac{0.02}{1.5} \right) - \tan^{-1} \left( \frac{-(0.04 - 0.02)}{1.5} \right) \right] = 0.0042$$

For  $x = 1.0$  m,

$$F_{13c} = \frac{1}{2\pi} \left[ \tan^{-1} \left( \frac{0.02}{1.0} \right) - \tan^{-1} \left( \frac{-(0.04 - 0.02)}{1.0} \right) \right] = 0.0064$$

Noting that  $F_{13} = F_{13a} + F_{13b} + F_{13c}$ , we find for  $x = 0.5$  m,  $F_{13} = 0.0127 + 0 + 0.0042 = 0.0169$ .

Likewise for  $x = 1.0$  m,  $F_{13} = 0.0064 + 0 + 0.0064 = 0.0128$ . The radiation incident upon the product is  $q_{in} = q_{21} + q_{31} = A_2 F_{21} \sigma T_1^4 + A_3 F_{31} \sigma T_3^4$ . Noting that  $A_2 F_{21} = A_1 F_{12} = A_1 (1 - F_{13})$  and  $A_1 = \pi DL$ , the preceding expression becomes

$$q_{in}' = q_{in} / L = \pi D \sigma \left[ T_2^4 (1 - F_{13}) + T_3^4 F_{13} \right] \quad (2)$$

For  $x = 0.5$  m,

Continued...

**PROBLEM 13.41 (Cont.)**

$$q'_{\text{in}} = \pi \times 0.01\text{m} \times 5.67 \times 10^{-8} \frac{\text{W}}{\text{m}^2 \cdot \text{K}^4} \times \left[ (500\text{K})^4 \times (1 - 0.0169) + (300\text{K})^4 \times 0.0169 \right] = 109.7 \text{ W/m} <$$

For  $x = 1.0 \text{ m}$ ,

$$q'_{\text{in}} = \pi \times 0.01\text{m} \times 5.67 \times 10^{-8} \frac{\text{W}}{\text{m}^2 \cdot \text{K}^4} \times \left[ (500\text{K})^4 \times (1 - 0.0128) + (300\text{K})^4 \times 0.0128 \right] = 110.1 \text{ W/m} <$$

(b) For  $\alpha = \pi/15$ ,

$$F_{13a} = \frac{1}{2\pi} \left[ \tan^{-1} \left( \frac{a + \gamma}{x} \right) - \tan^{-1} \left( \frac{-(b-a)}{x} \right) \right]$$

where  $\gamma = L \sin \alpha$ ,  $s_1 = a + L \sin \alpha$  and  $s_2 = -(b-a)$ .

For  $x = 0.5 \text{ m}$ ,

$$F_{13a} = \frac{1}{2\pi} \left[ \tan^{-1} \left( \frac{0.02 + 2 \sin(\pi/15)}{0.5} \right) - \tan^{-1} \left( \frac{-(0.04 - 0.02)}{0.5} \right) \right] = 0.1205$$

Likewise, for  $x = 1.0 \text{ m}$ ,  $F_{13a} = 0.0686$ .

From Eq. (1),

$$F_{13b} = \frac{1}{2\pi} \left[ \tan^{-1} \left( \frac{x}{a + \gamma} \right) - \tan^{-1} \left( \frac{\beta}{a + \gamma} \right) \right]$$

where  $\beta = L(1 - \cos \alpha)$ .

For  $x = 0.5 \text{ m}$ ,

$$F_{13b} = \frac{1}{2\pi} \left[ \tan^{-1} \left( \frac{0.5}{0.02 + 2 \sin(\pi/15)} \right) - \tan^{-1} \left( \frac{0.5 - 2(1 - \cos(\pi/15))}{0.02 + 2 \sin(\pi/15)} \right) \right] = 0.0072$$

Likewise, for  $x = 1.0 \text{ m}$ ,  $F_{13b} = 0.0026$ . The values of  $F_{13c}$  are the same as in part (a).

For  $x = 0.5 \text{ m}$ ,  $F_{13} = F_{13a} + F_{13b} + F_{13c} = 0.1205 + 0.0072 + 0.0042 = 0.1319$ . Likewise, for  $x = 1.0 \text{ m}$ ,  $F_{13} = 0.0686 + 0.0026 + 0.0064 = 0.0776$ .

Using Eq. (2) for  $x = 0.5 \text{ m}$ ,

$$q'_{\text{in}} = \pi \times 0.01\text{m} \times 5.67 \times 10^{-8} \frac{\text{W}}{\text{m}^2 \cdot \text{K}^4} \times \left[ (500\text{K})^4 (1 - 0.1319) + (300\text{K})^4 \times 0.1319 \right] = 98.5 \text{ W/m} <$$

Continued...

### PROBLEM 13.41 (Cont.)

Likewise for  $x = 1.0$  m,

$$q'_{\text{in}} = \pi \times 0.01\text{m} \times 5.67 \times 10^{-8} \frac{\text{W}}{\text{m}^2 \cdot \text{K}^4} \times \left[ (500\text{K})^4 (1 - 0.0776) + (300\text{K})^4 \times 0.0776 \right] = 103.8\text{W/m} \quad <$$

**COMMENTS:** (1) For the  $\alpha = 0$  case, the irradiation of the product at  $x = 0.5$  m is 99.6 % of the irradiation at  $x = 1$  m, where the irradiation is maximized. The influence of the oven openings is very small in the central portion of the oven. (2) Modifying the tilt angle of the upper panel heater is effective in controlling the radiative heating of the product. However, convection heating and/or cooling of the product will also be affected by the change in the oven geometry.

## PROBLEM 13.42

**KNOWN:** Two horizontal, very large parallel plates with prescribed surface conditions and temperatures.

**FIND:** (a) Irradiation to the top plate,  $G_1$ , (b) Radiosity of the top plate,  $J_1$ , (c) Radiosity of the lower plate,  $J_2$ , (d) Net radiative exchange between the plates per unit area of the plates.

**SCHEMATIC:**

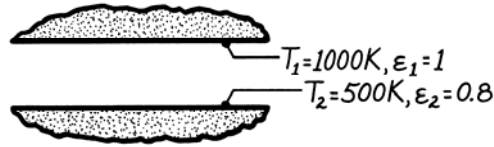

**ASSUMPTIONS:** (1) Plates are sufficiently large to form a two surface enclosure and (2) Surfaces are diffuse-gray and have uniform radiation and radiosity distributions.

**ANALYSIS:** (a) The irradiation to the upper plate is defined as the radiant flux incident on that surface. The irradiation to the upper plate  $G_1$  is comprised of flux emitted by surface 2 and reflected flux emitted by surface 1.

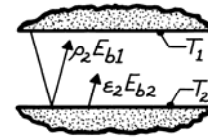

$$G_1 = \varepsilon_2 E_{b2} + \rho_2 E_{b1} = \varepsilon_2 \sigma T_2^4 + (1 - \varepsilon_2) \sigma T_1^4$$

$$G_1 = 0.8 \times 5.67 \times 10^{-8} \text{ W/m}^2 \cdot \text{K}^4 (500 \text{ K})^4 + (1 - 0.8) \times 5.67 \times 10^{-8} \text{ W/m}^2 \cdot \text{K}^4 (1000 \text{ K})^4$$

$$G_1 = 2835 \text{ W/m}^2 + 11,340 \text{ W/m}^2 = 14,175 \text{ W/m}^2. \quad <$$

(b) The radiosity is defined as the radiant flux leaving the surface by emission and reflection. For the blackbody surface 1, it follows that

$$J_1 = E_{b1} = \sigma T_1^4 = 5.67 \times 10^{-8} \text{ W/m}^2 \cdot \text{K}^4 (1000 \text{ K})^4 = 56,700 \text{ W/m}^2. \quad <$$

(c) The radiosity of surface 2 is then,

$$J_2 = \varepsilon_2 E_{b2} + \rho_2 G_2.$$

Since the upper plate is a blackbody, it follows that  $G_2 = E_{b1}$  and

$$J_2 = \varepsilon_2 E_{b1} + \rho_2 E_{b1} = \varepsilon_2 \sigma T_2^4 + 1(1 - \varepsilon_2) \sigma T_1^4 = 14,175 \text{ W/m}^2. \quad <$$

Note that  $J_2 = G_1$ . That is, the radiant flux leaving surface 2 ( $J_2$ ) is incident upon surface 1 ( $G_1$ ).

(d) The net radiation heat exchange per unit area can be found by three relations.

$$q_1'' = J_1 - G_1 = (56,700 - 14,175) \text{ W/m}^2 = 42,525 \text{ W/m}^2$$

$$q_{12}'' = J_1 - J_2 = (56,700 - 14,175) \text{ W/m}^2 = 42,525 \text{ W/m}^2 \quad <$$

The exchange relation, Eq. 13.24, is also appropriate with  $\varepsilon_1 = 1$ ,

$$q_1'' = -q_2'' = q_{12}''$$

$$q_1'' = \varepsilon_2 \sigma (T_1^4 - T_2^4) = 0.8 \times 5.67 \times 10^{-8} \text{ W/m}^2 \cdot \text{K}^4 (1000^4 - 500^4) \text{ K}^4 = 42,525 \text{ W/m}^2.$$

**COMMENT:** Since the plates are large, the assumption of uniform irradiation and radiosity distributions is excellent.

### PROBLEM 13.43

**KNOWN:** Dimensions and temperature of a flat-bottomed hole.

**FIND:** (a) Radiant power leaving the opening, (b) Effective emissivity of the cavity,  $\epsilon_e$ , (c) Limit of  $\epsilon_e$  as depth of hole increases.

**SCHEMATIC:**

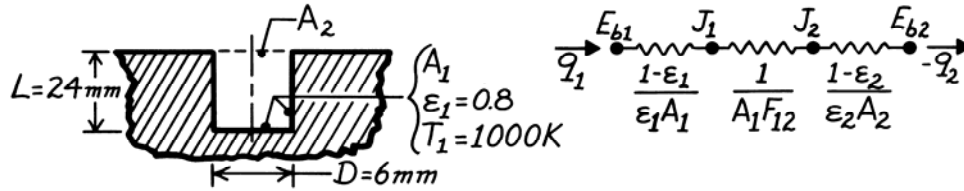

**ASSUMPTIONS:** (1) Hypothetical surface  $A_2$  is a blackbody at 0 K, (2) Cavity surface is isothermal, opaque and diffuse-gray with uniform radiosity and irradiation distributions.

**ANALYSIS:** Approximating  $A_2$  as a blackbody at 0 K implies that all of the radiation incident on  $A_2$  from the cavity results (directly or indirectly) from emission by the walls and escapes to the surroundings. It follows that for  $A_2$ ,  $\epsilon_2 = 1$  and  $J_2 = E_{b2} = 0$ .

(a) From the thermal circuit, the rate of radiation loss through the hole ( $A_2$ ) is

$$q_1 = (E_{b1} - E_{b2}) / \left[ \frac{1 - \epsilon_1}{\epsilon_1 A_1} + \frac{1}{A_1 F_{12}} + \frac{1 - \epsilon_2}{\epsilon_2 A_2} \right]. \quad (1)$$

Noting that  $F_{21} = 1$  and  $A_1 F_{12} = A_2 F_{21}$ , also that

$$A_1 = \pi D^2 / 4 + \pi D L = \pi D (D / 4 + L) = \pi (0.006 \text{ m}) (0.006 \text{ m} / 4 + 0.024 \text{ m}) = 4.807 \times 10^{-4} \text{ m}^2$$

$$A_2 = \pi D^2 / 4 = \pi (0.006 \text{ m})^2 / 4 = 2.827 \times 10^{-5} \text{ m}^2.$$

Substituting numerical values with  $E_b = \sigma T^4$ , find

$$q_1 = 5.67 \times 10^{-8} \text{ W/m}^2 \cdot \text{K}^4 (1000^4 - 0) \text{ K}^4 / \left[ \frac{1 - 0.8}{0.8 \times 4.807 \times 10^{-4} \text{ m}^2} + \frac{1}{2.827 \times 10^{-5} \text{ m}^2} + 0 \right]$$

$$q_1 = 1.580 \text{ W}. \quad <$$

(b) The effective emissivity,  $\epsilon_e$ , of the cavity is defined as the ratio of the radiant power leaving the cavity to that from a blackbody having the same area of the cavity opening and at the temperature of the inner surfaces of the cavity. For the cavity above,

$$\epsilon_e = \frac{q_1}{A_2 \sigma T_1^4}$$

$$\epsilon_e = 1.580 \text{ W} / 2.827 \times 10^{-5} \text{ m}^2 (5.67 \times 10^{-8} \text{ W/m}^2 \cdot \text{K}^4) (1000 \text{ K})^4 = 0.986. \quad <$$

(c) As the depth of the hole increases, the term  $(1 - \epsilon_1) / \epsilon_1 A_1$  goes to zero such that the remaining term in the denominator of Eq. (1) is  $1 / A_1 F_{12} = 1 / A_2 F_{21}$ . That is, as  $L$  increases,  $q_1 \rightarrow A_2 F_{21} E_{b1}$ . This implies that  $\epsilon_e \rightarrow 1$  as  $L$  increases. For  $L/D = 10$ , one would expect  $\epsilon_e = 0.999$  or better.



## PROBLEM 13.44

**KNOWN:** Temperatures and emissivity of glass surfaces.

**FIND:** Heat flux through the window for case 1:  $\varepsilon_1 = \varepsilon_2 = 0.95$ , case 2:  $\varepsilon_1 = \varepsilon_2 = 0.05$ , and case 3:  $\varepsilon_1 = 0.05$ ,  $\varepsilon_2 = 0.95$ .

**SCHEMATIC:**

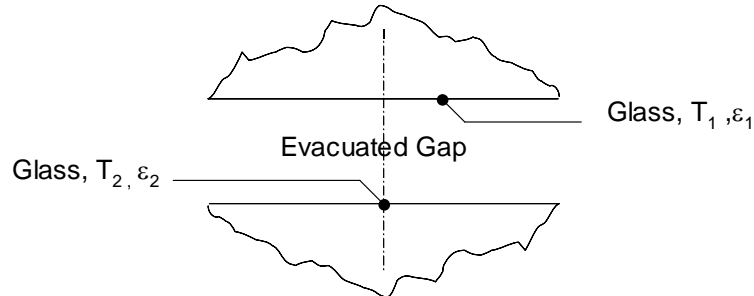

**ASSUMPTIONS:** (1) Diffuse-gray surfaces with uniform radiosity and irradiation distributions, (2) Infinite parallel glass surfaces.

**ANALYSIS:** For case 1, the net radiation heat flux between the glass sheets is

$$q_{rad}'' = \frac{\sigma(T_1^4 - T_2^4)}{\frac{1}{\varepsilon_1} + \frac{1}{\varepsilon_2} - 1} = \frac{5.67 \times 10^{-8} \text{ W/m}^2 \cdot \text{K}^4 (293\text{K}^4 - 263\text{K}^4)}{\frac{1}{0.95} + \frac{1}{0.95} - 1} = 133 \text{ W/m}^2 \quad <$$

Likewise, for case 2:  $\varepsilon_1 = \varepsilon_2 = 0.05$ ,  $q_{rad}'' = 3.76 \text{ W/m}^2$ , <

and for case 3:  $\varepsilon_1 = 0.05$ ,  $\varepsilon_2 = 0.95$ ,  $q_{rad}'' = 7.31 \text{ W/m}^2$ . <

**COMMENTS:** The reduction associated with case 2 is  $[(133 - 3.76)/133] \times 100 = 97\%$  while the reduction associated with case 3 is 94.5%. Both cases 2 and 3 provide a significant reduction in the heat flux relative to the uncoated glass of case 1. The decision to specify single- or double-surface coating depends on the cost of applying the low-emissivity coating.

### PROBLEM 13.45

**KNOWN:** Long V-groove machined in an isothermal block.

**FIND:** Radiant flux leaving the groove to the surroundings and effective emissivity.

**SCHEMATIC:**

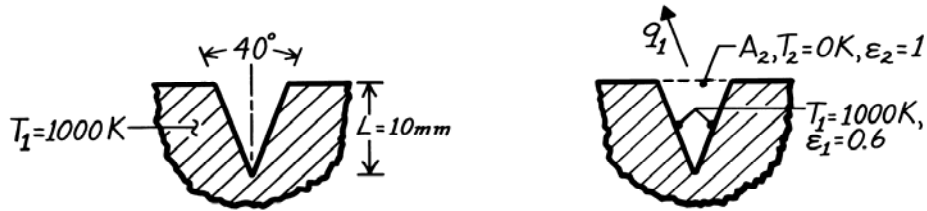

**ASSUMPTIONS:** (1) Groove surface is diffuse-gray with uniform irradiation and radiosity distributions, (2) Groove is infinitely long, (3) Block is isothermal.

**ANALYSIS:** Define the hypothetical surface  $A_2$  with  $T_2 = 0$  K. The net radiation leaving  $A_1$ ,  $q_1$ , will pass to the surroundings. From the two surface enclosure analysis, Eq. 13.23,

$$q_1 = -q_2 = \frac{\sigma(T_1^4 - T_2^4)}{\frac{1 - \epsilon_1}{\epsilon_1 A_1} + \frac{1}{A_1 F_{12}} + \frac{1 - \epsilon_2}{\epsilon_2 A_2}}$$

Recognize that  $\epsilon_2 = 1$  and that from reciprocity,  $A_1 F_{12} = A_2 F_{21}$  where  $F_{21} = 1$ . Hence,

$$\frac{q_1}{A_2} = \frac{\sigma(T_1^4 - T_2^4)}{\frac{1 - \epsilon_1}{\epsilon_1} \frac{A_2}{A_1} + 1}$$

With  $A_2/A_1 = 2\ell \tan 20^\circ / (2\ell / \cos 20^\circ) = \sin 20^\circ$ , find

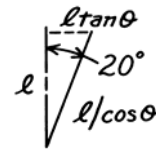

$$q_1'' = \frac{5.67 \times 10^{-8} \text{ W/m}^2 \cdot \text{K}^4 (1000^4 - 0) \text{ K}^4}{\frac{(1 - 0.6)}{0.6} \times \sin 20^\circ + 1} = 46.17 \text{ kW/m}^2. \quad <$$

The effective emissivity of the groove follows from the definition given in Problem 13.43 as the ratio of the radiant power leaving the cavity to that from a blackbody having the area of the cavity opening and at the same temperature as the cavity surface. For the present situation,

$$\epsilon_e = \frac{q_1''}{E_b(T_1)} = \frac{q_1''}{\sigma T_1^4} = \frac{46.17 \times 10^3 \text{ W/m}^2}{5.67 \times 10^{-8} \text{ W/m}^2 \cdot \text{K}^4 (1000 \text{ K})^4} = 0.814. \quad <$$

**COMMENTS:** (1) Note the use of the hypothetical surface defined as black at 0 K. This surface does not emit and absorbs all radiation on it; hence, is the radiant power to the surroundings. (2) Neither the irradiation or radiosity distributions are uniform. How will this affect your predictions?

### PROBLEM 13.46

**KNOWN:** Approximate wave geometry, hemispherical emissivity of water,  $\epsilon = 0.96$ .

**FIND:** (a) Effective emissivity of the water surface for  $\alpha = 3\pi/4$ , (b) Plot of the effective emissivity normalized by the hemispherical emissivity of water,  $\epsilon_{\text{eff}}/\epsilon$ , over the range  $\pi/2 \leq \alpha \leq \pi$ .

**SCHEMATIC:**

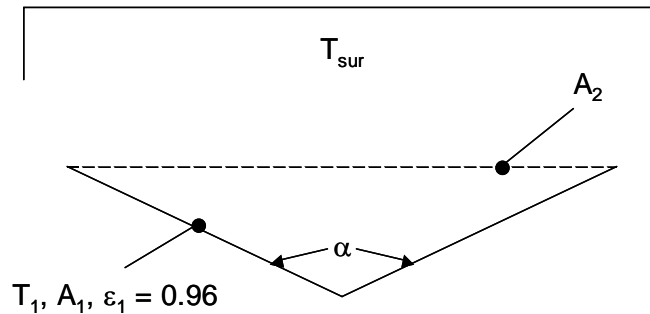

**ASSUMPTIONS:** (1) Two-dimensional system, (2) Diffuse, gray surfaces.

**ANALYSIS:** (a) The effective emissivity is defined by the relation

$$\epsilon_{\text{eff}} A_2 \sigma (T_1^4 - T_{\text{sur}}^4) = q_{12} = \frac{\sigma (T_1^4 - T_{\text{sur}}^4)}{\frac{1 - \epsilon_1}{\epsilon_1 A_1} + \frac{1}{A_1 F_{12}}}$$

From the schematic we see that  $A_2/A_1 = \sin(\alpha/2)$  and  $F_{21} = 1$ . Therefore,  $F_{12} = A_2 F_{21}/A_1 = \sin(\alpha/2)$  and the expression for the effective emissivity is

$$\epsilon_{\text{eff}} = \frac{1}{\frac{A_2(1 - \epsilon_1)}{\epsilon_1 A_1} + \frac{A_2}{A_1 F_{12}}} = \frac{1}{\frac{\sin(\alpha/2)(1 - \epsilon_1)}{\epsilon_1} + 1} = \frac{1}{\frac{\sin(3\pi/8)(1 - 0.96)}{0.96} + 1} = 0.963 \quad <$$

(b) The dependence of the normalized effective emissivity to the wave angle is shown in the plot below.

Continued...

### PROBLEM 13.46 (Cont.)

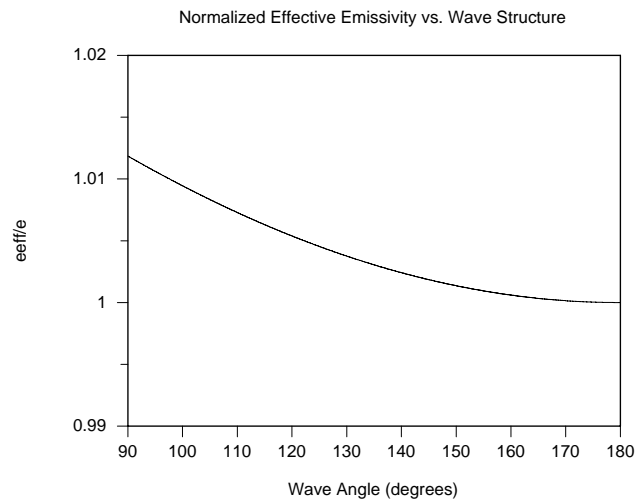

Comment: Although water exhibits nearly black behavior, and the sensitivity of the effective emissivity to the wave structure is small, the heat balance of the earth could be affected by approximately 1% depending on the sea roughness. These types of difficult-to-measure effects have led to debate on issues related to earth's energy balance.

### PROBLEM 13.47

**KNOWN:** Cavities formed by a cone, cylinder, and sphere having the same opening size ( $d$ ) and major dimension ( $L$ ) with prescribed wall emissivity.

**FIND:** (a) View factor between the inner surface of each cavity and the opening of the cavity; (b) Effective emissivity of each cavity as defined in Problem 13.43, if the walls are diffuse-gray with  $\varepsilon_w$ ; and (c) Compute and plot  $\varepsilon_e$  as a function of the major dimension-to-opening size ratio,  $L/d$ , over the range from 1 to 10 for wall emissivities of  $\varepsilon_w = 0.5, 0.7, \text{ and } 0.9$ .

**SCHEMATIC:**

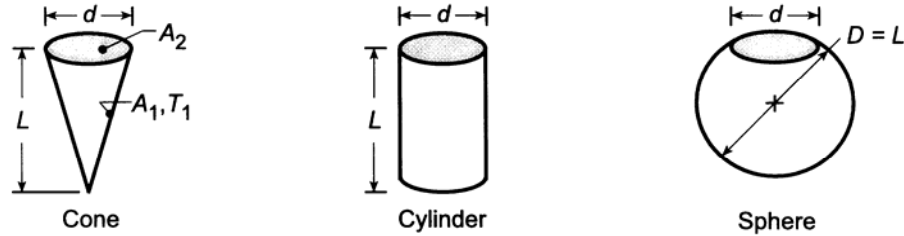

**ASSUMPTIONS:** (1) Diffuse-gray surfaces, (2) Uniform radiosity over the surfaces.

**ANALYSIS:** (a) Using the summation rule and reciprocity, determine the view factor  $F_{12}$  for each of the cavities considered as a two-surface enclosure.

*Cone:*  $F_{21} + F_{22} = F_{21} + 0 = 1 \quad F_{21} = 1$

$$F_{12} = A_2 F_{21} / A_1 = (\pi d^2 / 4) / (\pi d / 2) \left[ L^2 + (d/2)^2 \right]^{1/2} = (1/2) \left[ (L/d)^2 + 1/4 \right]^{-1/2} <$$

*Cylinder:*  $F_{21} = 1$

$$F_{12} = A_2 F_{21} / A_1 = A_2 / A_1 = (\pi d^2 / 4) / [\pi d L + \pi d^2 / 4] = (1 + 4L/d)^{-1} <$$

*Sphere:*  $F_{21} = 1$

$$F_{12} = A_2 F_{21} / A_1 = A_2 / A_1 = (\pi d^2 / 4) / [\pi D^2 - \pi d^2 / 4] = (4D^2 / d^2 - 1)^{-1} <$$

(b) The effective emissivity of the cavity is defined as

$$\varepsilon_{\text{eff}} = q_{12} / q_c$$

where  $q_c = A_2 \sigma T_1^4$  which presumes the opening is a black surface at  $T_1$  and for the two-surface enclosure,

$$q_{12} = \frac{\sigma (T_1^4 - T_2^4)}{(1 - \varepsilon_1) / \varepsilon_1 A_1 + 1 / A_1 F_{12} + (1 - \varepsilon_2) / \varepsilon_2 A_2} = \frac{A_1 \sigma T_1^4}{(1 - \varepsilon_1) / \varepsilon_1 + 1 / F_{12}}$$

since  $T_2 = 0\text{K}$  and  $\varepsilon_2 = 1$ . Hence, since  $A_2 / A_1 = F_{12}$  for all the cavities, with  $\varepsilon_1 = \varepsilon_w$

$$\varepsilon_{\text{eff}} = \frac{1 / F_{12}}{(1 - \varepsilon_w) / \varepsilon_w + 1 / F_{12}} = \frac{1}{F_{12} (1 - \varepsilon_w) / \varepsilon_w + 1}$$

*Cone:*  $\varepsilon_{\text{eff}} = 1 / \left\{ (1/2) \left[ (L/d)^2 + 1/4 \right]^{-1/2} (1 - \varepsilon_w) / \varepsilon_w + 1 \right\} \quad (1) <$

Continued ...

### PROBLEM 13.47 (Cont.)

Cylinder: 
$$\varepsilon_{\text{eff}} = 1 / \left\{ [1 + 4L/d]^{-1} (1 - \varepsilon_w) / \varepsilon_w + 1 \right\} \quad (2) <$$

Sphere: 
$$\varepsilon_{\text{eff}} = 1 / \left\{ [4D^2/d^2 - 1]^{-1} (1 - \varepsilon_w) / \varepsilon_w + 1 \right\} \quad (3) <$$

(c) Using the *IHT* Workspace with eqs. (1,2,3), the effective emissivity was computed as a function of  $L/d$  (cone, cylinder and sphere) for selected wall emissivities. The results are plotted below.

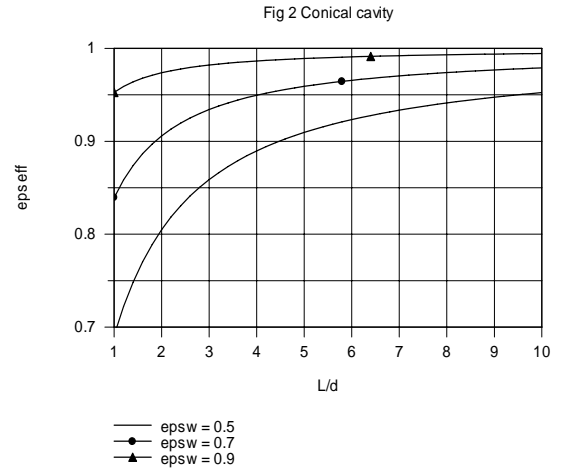
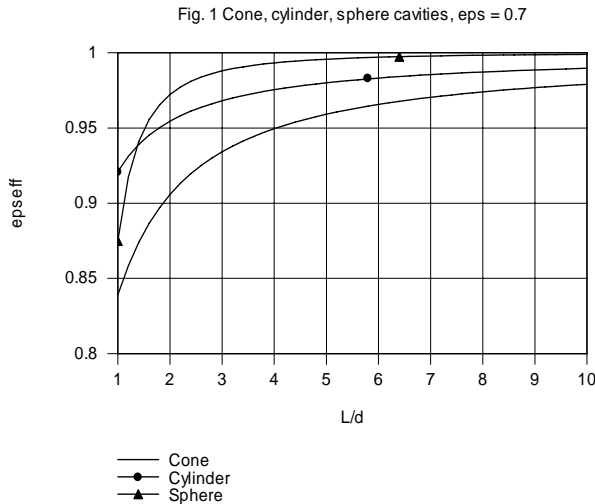

In Fig. 1,  $\varepsilon_{\text{eff}}$  is shown as a function of  $L/d$  for  $\varepsilon_w = 0.7$ . For larger  $L/d$ , the sphere has the highest  $\varepsilon_{\text{eff}}$  and the cone the lowest. Figures 2, 3 and 4 illustrate the  $\varepsilon_{\text{eff}}$  vs.  $L/d$  for each of the cavity types. As expected,  $\varepsilon_{\text{eff}}$  increases with increasing wall emissivity.

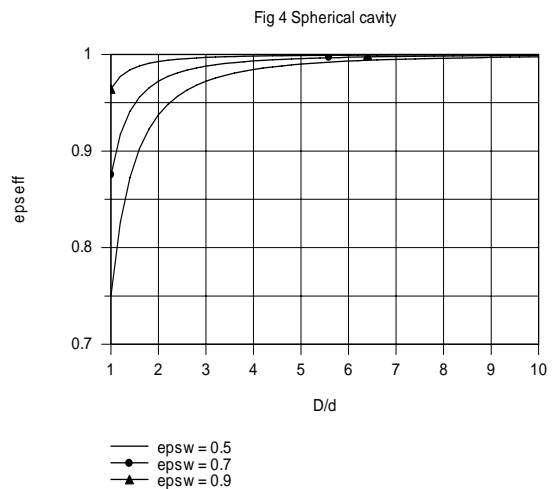
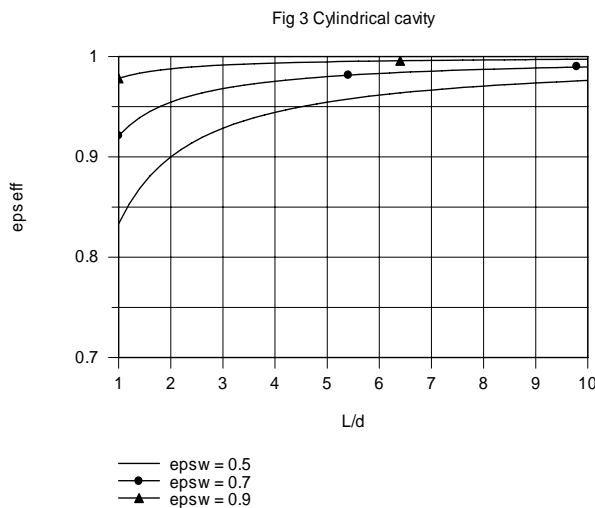

Note that for the spherical cavity, with  $L/d \geq 5$ ,  $\varepsilon_{\text{eff}} > 0.98$  even with  $\varepsilon_w$  as low as 0.5. This feature makes the use of spherical cavities for high performance radiometry applications attractive since  $\varepsilon_{\text{eff}}$  is not very sensitive to  $\varepsilon_w$ .

**COMMENTS:** In Fig. 1, comparing  $\varepsilon_{\text{eff}}$  for the three cavity types, can you give a physical explanation for the results?

### PROBLEM 13.48

**KNOWN:** Dimensions of attic. Emissivity of aluminum foil and of surfaces prior to application of the foil.

**FIND:** (a) Reduction of radiation heat transfer from the hot roof to the attic floor if foil is installed on the bottom of the roof, (b) Reduction in radiation heat load if foil is installed on the top of the attic floor, (c) Reduction if foiled is installed on both the attic floor and bottom of roof.

**SCHEMATIC:**

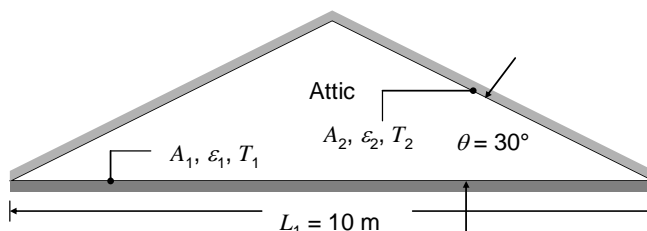

**ASSUMPTIONS:** (1) Diffuse-gray surfaces of uniform radiosity and irradiation, (2) Temperatures of surfaces are unaffected by surface treatment, (3) Two-dimensional configuration.

**ANALYSIS:** From Eqn. 13.23 we know that the ratio of the radiation heat load after installation of the foil to the radiation heat load prior to the installation of the foil is

$$R = \left[ \frac{1 - \epsilon_o}{\epsilon_o A_1} + \frac{1}{A_1 F_{12}} + \frac{1 - \epsilon_o}{\epsilon_o A_2} \right] \bigg/ \left[ \frac{1 - \epsilon_1}{\epsilon_1 A_1} + \frac{1}{A_1 F_{12}} + \frac{1 - \epsilon_2}{\epsilon_2 A_2} \right] \quad (1)$$

On a per-unit depth basis,  $A_1 = 10 \text{ m}^2$  and  $A_2 = 10 \text{ m}^2 / \cos(30^\circ) = 11.55 \text{ m}^2$ , while from inspection,  $F_{12} = 1$ .

(a)  $\epsilon_1 = 0.85$ ,  $\epsilon_2 = 0.07$ . Evaluation of Eqn. (1) yields  $R = 0.105$ . <

(b)  $\epsilon_1 = 0.07$ ,  $\epsilon_2 = 0.85$ . Evaluation of Eqn. (1) yields  $R = 0.092$ . <

(c)  $\epsilon_1 = \epsilon_2 = 0.07$ . Evaluation of Eqn. (1) yields  $R = 0.052$ . <

**COMMENTS:** (1) The reduction in the radiation heat load is least when the foil is installed on the bottom of the attic roof only. The surface formed by the attic roof is relatively large compared to Surface 1. As the roof becomes more steeply pitched,  $A_2$  will increase and will eventually form a large surroundings. Installing foil on the roof, as its area becomes much larger, will become more ineffective. (2) The reduction is most significant when both surfaces are covered with foil, as expected. (3) Over time, the foil installed on the floor may become covered with a layer of dust, reducing the effectiveness of the foil installation on that surface.

### PROBLEM 13.49

**KNOWN:** Long, thin-walled horizontal tube with radiation shield having an air gap of 10 mm. Emissivities and temperatures of surfaces are prescribed.

**FIND:** Radiant heat transfer from the tube per unit length.

**SCHEMATIC:**

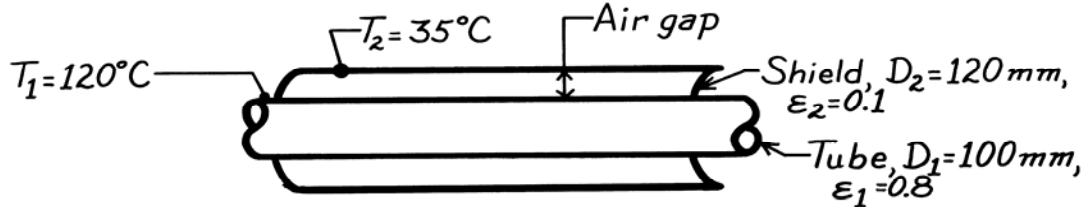

**ASSUMPTIONS:** (1) Tube and shield are very long, (2) Surfaces at uniform temperatures, (3) Surfaces are diffuse-gray.

**ANALYSIS:** The long tube and shield form a two surface enclosure, and since the surfaces are diffuse-gray, the radiant heat transfer from the tube, according to Eq. 13.23, is

$$q_{12} = \frac{\sigma(T_1^4 - T_2^4)}{\frac{1 - \epsilon_1}{\epsilon_1 A_1} + \frac{1}{A_1 F_{12}} + \frac{1 - \epsilon_2}{\epsilon_2 A_2}} \quad (1)$$

By inspection,  $F_{12} = 1$ . Note that

$$A_1 = \pi D_1 \ell \quad \text{and} \quad A_2 = \pi D_2 \ell$$

where  $\ell$  is the length of the tube and shield. Dividing Eq. (1) by  $\ell$ , find the heat rate per unit length,

$$q'_{12} = \frac{q_{12}}{\ell} = \frac{5.67 \times 10^{-8} \text{ W/m}^2 \cdot \text{K} \left[ (273 + 120)^4 - (273 + 35)^4 \right] \text{ K}^4}{\frac{1 - 0.8}{0.8 \pi (100 \times 10^{-3} \text{ m})} + \frac{1}{\pi (100 \times 10^{-3} \text{ m}) \times 1} + \frac{1 - 0.1}{0.1 \pi (120 \times 10^{-3} \text{ m})}}$$

$$q'_{12} = \frac{842.3 \text{ W/m}^2}{(0.7958 + 3.183 + 23.87) \text{ m}^{-1}} = 30.2 \text{ W/m.} \quad <$$

**COMMENTS:** Recognize that convective heat transfer would be important in this annular air gap. Suitable correlations to estimate the heat transfer coefficient are given in Chapter 9.



## PROBLEM 13.50

**KNOWN:** Dimensions and temperature of an anodized aluminum sheet radiating to deep space.

**FIND:** (a) Net radiation from both sides of a 200 mm × 200 mm sheet, (b) Net radiation from the sheet with 3-mm diameter holes spaced 5 mm apart, (c) Net radiation from the sheet with 3-mm, flat-bottomed diameter holes of depth 2 mm, spaced 5 mm apart, (d) Ratio of net heat transfer to sheet mass for the three configurations.

**SCHEMATIC:**

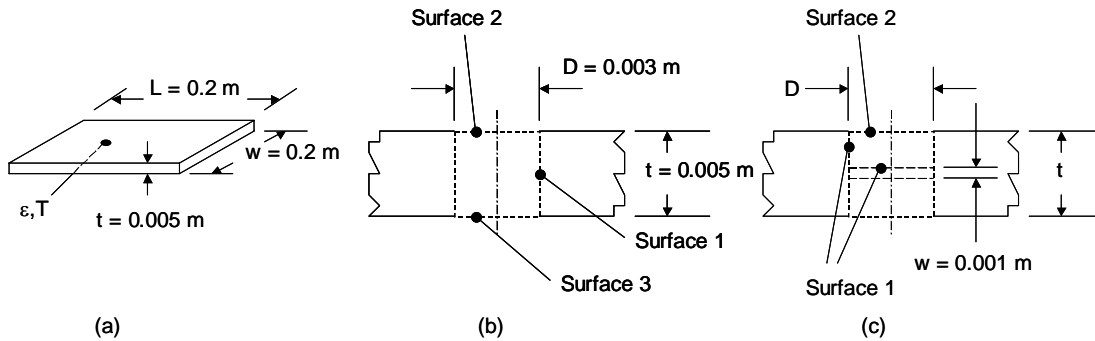

**ASSUMPTIONS:** Diffuse, gray behavior.

**PROPERTIES:** Table A.11, anodized aluminum: ( $T = 300 \text{ K}$ ):  $\varepsilon = 0.82$ . Table A.1 aluminum ( $T = 300 \text{ K}$ ):  $\rho = 2702 \text{ kg/m}^3$ .

**ANALYSIS:** (a) For 2 sides,

$$E = 2Lw\varepsilon\sigma T_s^4 = 2 \times 0.2 \text{ m} \times 0.2 \text{ m} \times 0.82 \times 5.67 \times 10^{-8} \frac{\text{W}}{\text{m}^2 \cdot \text{K}^4} \times (300 \text{ K})^4 = 30.13 \text{ W} <$$

(b) The number of holes is  $N = Lw/s^2$  where  $s = 5 \text{ mm}$  is the hole spacing. Therefore,  $N = (0.2 \text{ m} \times 0.2 \text{ m}) / (0.005 \text{ m})^2 = 1600$ . The sheet area occupied by holes is  $A_h = N\pi D^2/4 = 1600 \times \pi \times (0.003 \text{ m})^2/4 = 11.31 \times 10^{-3} \text{ m}^2$ . The emission from the entire sheet is  $E = NE_h + E_s$ .

The emission from the flat sheet area is  $E_s = 2(Lw - A_h)\varepsilon\sigma T_s^4$ , or

$$E_s = 2 \times (0.2 \text{ m} \times 0.2 \text{ m} - 11.31 \times 10^{-3} \text{ m}^2) \times 0.82 \times 5.67 \times 10^{-8} \frac{\text{W}}{\text{m}^2 \cdot \text{K}^4} \times (300 \text{ K})^4 = 21.61 \text{ W}$$

Now, consider one hole. From the coaxial parallel disk results of Table 13.2,

$$S = 1 + \frac{1 + 0.32}{0.32} = 13.11 \quad ; \quad F_{23} = \frac{1}{2} \left[ 13.11 - (13.11^2 - 4)^{1/2} \right] = 0.0762$$

From the summation rule and reciprocity,

Continued...

**PROBLEM 13.50 (Cont.)**

$F_{21} = 1 - F_{23}$  and  $F_{12} = (1 - F_{23})A_2/A_1 = (1 - F_{23})D/4t = (1 - 0.0762) \times 3/(4 \times 5) = 0.139$ .  
Therefore,  $F_{1-(23)} = 0.277$  and the emission from one hole is

$$E_h = \frac{\sigma T^4}{\frac{1 - \epsilon_1}{\epsilon_1 A_1} + \frac{1}{A_1 F_{1-(23)}}} = \frac{5.67 \times 10^{-8} \frac{\text{W}}{\text{m}^2 \cdot \text{K}^4} \times (300\text{K})^4}{\frac{1 - 0.82}{0.82 \times \pi \times 0.05\text{m} \times 0.03\text{m}} + \frac{1}{\pi \times 0.005\text{m} \times 0.003\text{m} \times 0.277}} = 5.65 \times 10^{-3} \text{ W}$$

Therefore,  $E = 21.61 \text{ W} + 1600 \times 5.65 \times 10^{-3} \text{ W} = 30.65 \text{ W}$

<

(c) We shall treat the sides and bottom of the cavity as one surface with  $F_{21} = 1$ . For one opening,

$$E_h = \frac{\sigma T^4}{\frac{1 - \epsilon_1}{\epsilon_1 A_1} + \frac{1}{A_1 F_{12}}} = \frac{\sigma T^4}{\frac{1 - \epsilon_1}{\epsilon_1 A_1} + \frac{1}{A_2 F_{21}}} = \frac{5.67 \times 10^{-8} \frac{\text{W}}{\text{m}^2 \cdot \text{K}^4}}{\frac{1 - 0.82}{0.82 \times (\pi \times 0.003\text{m} \times 0.002\text{m} + \pi \times (0.003\text{m})^2 / 4)} + \frac{1}{\pi \times [(0.003\text{m})^2 / 4] \times 1}}$$

$E_h = 3.063 \times 10^{-3} \text{ W}$ . Therefore for both sides of the sheet,

$E = 21.61 \text{ W} + 1600 \times 2 \times 3.063 \times 10^{-3} \text{ W} = 31.41 \text{ W}$

<

(d) The mass of the sheet in part (a) is  $M_a = Lwt\rho = 0.2\text{m} \times 0.2\text{m} \times 0.005\text{m} \times 2702 \text{ kg/m}^3 = 0.540 \text{ kg}$ . For part (b),  $M_b = (Lwt - N\pi D^2 t/4)\rho = (0.2\text{m} \times 0.2\text{m} \times 0.005\text{m} - 1600 \times \pi \times (0.003\text{m})^2 \times 0.005\text{m}/4) \times 2702 \text{ kg/m}^3 = 0.387 \text{ kg}$ . For part (c),  $M_c = (Lwt - N\pi D^2(t - w)/4)\rho = (0.2\text{m} \times 0.2\text{m} \times 0.005\text{m} - 1600 \times \pi \times (0.003\text{m})^2 \times (0.004\text{m})/4) \times 2702 \text{ kg/m}^3 = 0.418 \text{ kg}$ .

Therefore, the ratios of the net radiation heat transfer to mass,  $R$ , for the three parts of the problem are:

Part (a):  $R = E/M_a = 30.13 \text{ W}/0.540 \text{ kg} = 55.8 \text{ W/kg}$ .

Part (b):  $R = E/M_b = 30.65 \text{ W}/0.387 \text{ kg} = 79.2 \text{ W/kg}$ .

Part (c):  $R = E/M_c = 31.41 \text{ W}/0.418 \text{ kg} = 75.1 \text{ W/kg}$ .

<

**COMMENTS:** (1) Boring holes in the sheet results in increased heat transfer rates and reduced mass. If a specific heat loss is required, the size of the sheets with the bored holes could be reduced slightly, leading to reduction in the mass of the bored aluminum sheet. (2) Holes that are bored completely through the sheet may lead to large conduction resistance along the sheet and, in turn, spatial temperature variations on the aluminum sheet. Since the two alternative designs involving holes are characterized by nearly the same emission-to-mass ratio, the third option might be preferred.

### PROBLEM 13.51

**KNOWN:** Temperature, emissivity and dimensions of a rectangular fin array radiating to deep space.

**FIND:** (a) Rate of radiation transfer per unit length from a unit section to space, (b) Effect of emissivity on heat rejection.

**SCHEMATIC:**

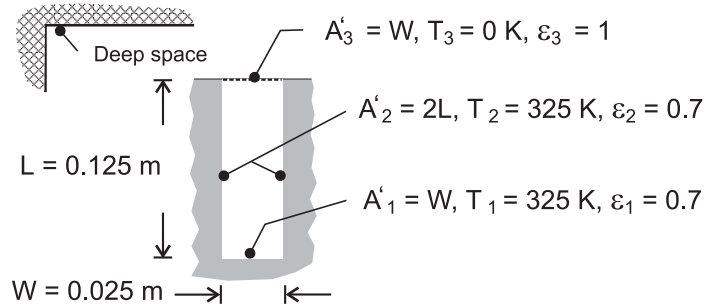

**ASSUMPTIONS:** (1) Diffuse/gray surface behavior, (2) Length of array (normal to page) is much larger than  $W$  and  $L$ , (3) Isothermal surfaces.

**ANALYSIS:** (a) Since the sides and base of the U-section have the same temperature and emissivity, they can be treated as a single surface and the U-section becomes a two-surface enclosure. Deep space may be represented by the hypothetical surface  $A'_3$ , which acts as a blackbody at absolute zero temperature. From Eq. 13.23, with  $T_1 = T_2 = T$  and  $\varepsilon_1 = \varepsilon_2 = \varepsilon$ ,

$$q'_{(1,2)3} = \frac{\sigma(T^4 - T_3^4)}{\frac{1-\varepsilon}{\varepsilon A'_{(1,2)}} + \frac{1}{A'_{(1,2)} F_{(1,2)3}} + \frac{1-\varepsilon}{\varepsilon A'_3}}$$

where  $A'_{(1,2)} = 2L + W$ ,  $A'_3 = W$ ,  $A'_{(1,2)} F_{(1,2)3} = A'_3 F_{3(1,2)} = W$ . Hence,

$$q'_{(1,2)3} = \frac{\sigma T^4}{\frac{1-\varepsilon}{\varepsilon(2L+W)} + \frac{1}{W} + \frac{1-\varepsilon}{\varepsilon W}}$$

$$q'_{(1,2)3} = \frac{5.67 \times 10^{-8} \text{ W/m}^2 \cdot \text{K}^4 (325 \text{ K})^4}{\frac{1-0.70}{0.70(0.275\text{m})} + \frac{1}{0.025\text{m}} + 0} = 15.2 \text{ W/m} \quad <$$

(b) For  $\varepsilon = 0.7$  emission from the base of the U-section is  $q'_b = \varepsilon A'_1 \sigma T^4 = 0.7 \times 0.025\text{m} \times 5.67 \times 10^{-8} \text{ W/m}^2 \cdot \text{K}^4 (325 \text{ K})^4 = 11.1 \text{ W/m}$ . The effect of  $\varepsilon$  on  $q'_{(1,2)3}$  and  $q'_b$  is shown as follows.

Continued ...

**PROBLEM 13.51 (Cont.)**

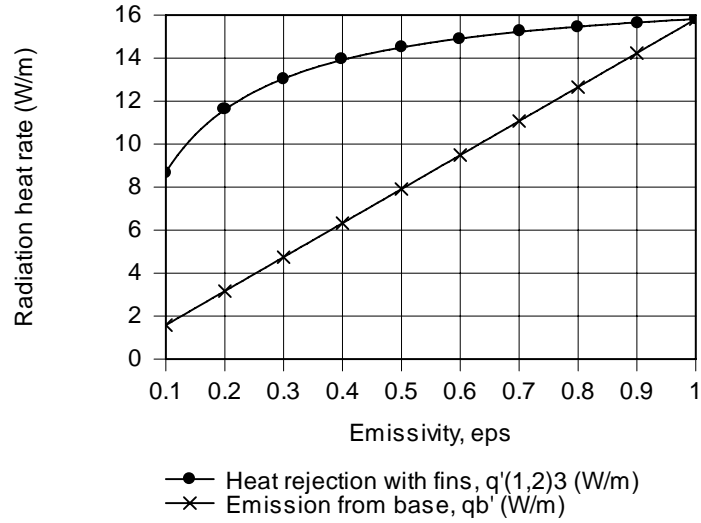

The effect of the fins on heat transfer enhancement increases with decreasing emissivity.

**COMMENTS:** Note that, if the surfaces behaved as blackbodies ( $\epsilon_1 = \epsilon_2 = 1.0$ ), the U-section becomes a blackbody cavity for which heat rejection is simply  $A'_3 E_b(T) = q'_b$ . Hence, it is no surprise that the  $q'_b \rightarrow q'_{(1,2)3}$  as  $\epsilon \rightarrow 1$  in the foregoing figure. For  $\epsilon = 1$ , no enhancement is provided by the fins.

### PROBLEM 13.52

**KNOWN:** Power dissipation of electronic device and thermal resistance associated with attachment to inner wall of a cubical container. Emissivity of outer surface of container and wall temperature of service bay.

**FIND:** Temperatures of cubical container and device.

**SCHEMATIC:**

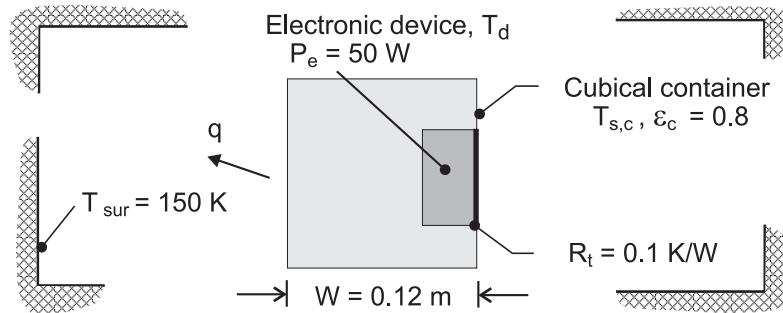

**ASSUMPTIONS:** (1) Steady-state, (2) Device and container are isothermal, (3) Heat transfer from the container is exclusively by radiation exchange with bay (small surface in a large enclosure), (4) Container surface may be approximated as diffuse/gray.

**ANALYSIS:** From Eq. 13.27

$$P_e = q = \sigma (6W^2) \epsilon_c (T_{s,c}^4 - T_{sur}^4)$$

$$T_{s,c} = \left[ \frac{q}{\sigma (6W^2) \epsilon_c} + T_{sur}^4 \right]^{1/4}$$

$$T_{s,c} = \left[ \frac{50 \text{ W}}{5.67 \times 10^{-8} \text{ W/m}^2 \cdot \text{K}^4 \times 6(0.12 \text{ m})^2 \times 0.8} + (150 \text{ K})^4 \right]^{1/4} = 339.4 \text{ K} = 66.4^\circ\text{C} \quad <$$

With  $q = (T_d - T_{s,c}) / R_t$ ,

$$T_d = q R_t + T_{s,c} = 50 \text{ W} \times 0.1 \text{ K/W} + 66.4^\circ\text{C} = 71.4^\circ\text{C} \quad <$$

**COMMENTS:** If the temperature of the device is too large to insure reliable operation, it may be reduced by increasing  $\epsilon_c$  or  $W$ .

### PROBLEM 13.53

**KNOWN:** Long electrical conductor with known heat dissipation is cooled by a concentric tube arrangement.

**FIND:** Surface temperature of the conductor.

**SCHEMATIC:**

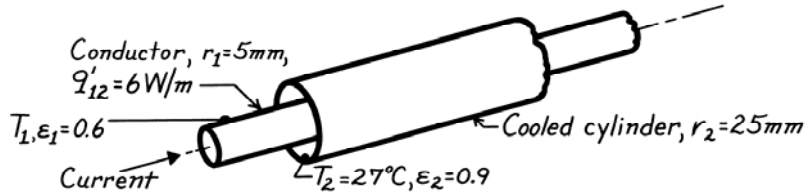

**ASSUMPTIONS:** (1) Surfaces are diffuse-gray, (2) Conductor and cooling tube are concentric and very long, (3) Space between surfaces is evacuated.

**ANALYSIS:** The heat transfer by radiation exchange between the conductor and the concentric, cooled cylinder is given by Eq. 13.25. For a unit length,

$$q'_{12} = \frac{q_{12}}{\ell} = \sigma \cdot 2\pi r_1 \left( T_1^4 - T_2^4 \right) / \left[ \frac{1}{\epsilon_1} + \frac{1 - \epsilon_2}{\epsilon_2} \left( \frac{r_1}{r_2} \right) \right] \quad (1)$$

where  $A_1 = 2\pi r_1 \cdot \ell$ . Solving for  $T_1$  and substituting numerical values, find

$$T_1 = \left\{ T_2^4 + \frac{q'_{12}}{\sigma \cdot 2\pi r_1} \left[ \frac{1}{\epsilon_1} + \frac{1 - \epsilon_2}{\epsilon_2} \left( \frac{r_1}{r_2} \right) \right] \right\}^{1/4}$$

$$T_1 = \left\{ (27 + 273)^4 \text{ K}^4 + \frac{6 \text{ W/m}}{5.67 \times 10^{-8} \text{ W/m}^2 \cdot \text{K}^4 \times 2\pi (0.005\text{m})} \left[ \frac{1}{0.6} + \frac{1 - 0.9}{0.9} \left( \frac{5}{25} \right) \right] \right\}^{1/4}$$

$$T_1 = \left\{ (300 \text{ K})^4 + 3.368 \times 10^9 \text{ K}^4 [1.667 + 0.00222] \right\}^{1/4} \quad (2)$$

$$T_1 = 342.3 \text{ K} = 69^\circ\text{C}.$$

<

**COMMENTS:** (1) Note that Eq. (1) implies that  $F_{12} = 1$ . From Eq. (2) by comparison of the second term in the brackets involving  $\epsilon_2$ , note that the influence of  $\epsilon_2$  is small. This follows since  $r_1 \ll r_2$ .

### PROBLEM 13.54

**KNOWN:** Temperatures and emissivities of spherical surfaces which form an enclosure.

**FIND:** Evaporation rate of oxygen stored in inner container.

**SCHEMATIC:**

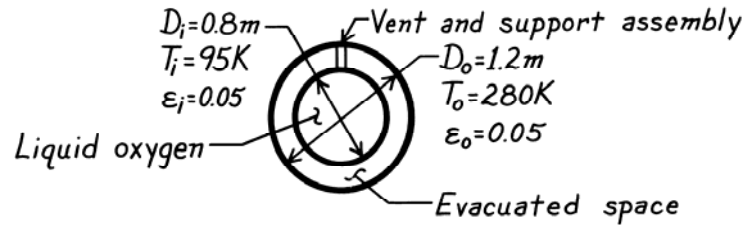

**PROPERTIES:** Oxygen (given):  $h_{fg} = 2.13 \times 10^5 \text{ J/kg}$ .

**ASSUMPTIONS:** (1) Opaque, diffuse-gray surfaces, (2) Evacuated space between surfaces, (3) Negligible heat transfer along vent and support assembly.

**ANALYSIS:** From an energy balance on the inner container, the net radiation heat transfer to the container may be equated to the evaporative heat loss

$$q_{oi} = \dot{m}h_{fg}$$

Substituting from Eq. 13.26, where  $q_{oi} = -q_{io}$  and  $F_{iio} = 1$

$$\dot{m} = \frac{-\sigma(\pi D_i^2)(T_i^4 - T_o^4)}{h_{fg} \left[ \frac{1}{\varepsilon_i} + \frac{1 - \varepsilon_o}{\varepsilon_o} \left( \frac{r_i}{r_o} \right)^2 \right]}$$

$$\dot{m} = \frac{-5.67 \times 10^{-8} \text{ W/m}^2 \cdot \text{K}^4 \times \pi (0.8 \text{ m})^2 (95^4 - 280^4) \text{ K}^4}{2.13 \times 10^5 \text{ J/kg} \left[ \frac{1}{0.05} + \frac{0.95}{0.05} \left( \frac{0.4}{0.6} \right)^2 \right]}$$

$$\dot{m} = 1.14 \times 10^{-4} \text{ kg/s.}$$

<

**COMMENTS:** This loss could be reduced by insulating the outer surface of the outer container and/or by inserting a radiation shield between the containers.

### PROBLEM 13.55

**KNOWN:** Emissivities, diameters and temperatures of concentric spheres.

**FIND:** (a) Radiation transfer rate for black surfaces. (b) Radiation transfer rate for diffuse-gray surfaces, (c) Effects of increasing the diameter and assuming blackbody behavior for the outer sphere. (d) Effect of emissivities on net radiation exchange.

**SCHEMATIC:**

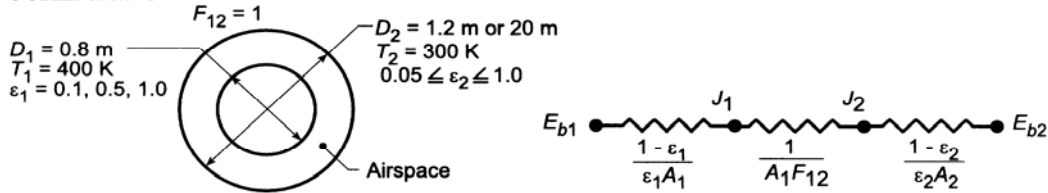

**ASSUMPTIONS:** (1) Blackbody or diffuse-gray surface behavior.

**ANALYSIS:** (a) Assuming blackbody behavior, it follows that  $q_{ij} = A_i F_{ij} (J_i - J_j)$  where  $J_i = \sigma T_i^4$  and  $J_j = \sigma T_j^4$ . Therefore,

$$q_{12} = A_1 F_{12} \sigma (T_1^4 - T_2^4) = \pi (0.8 \text{ m})^2 (1) 5.67 \times 10^{-8} \text{ W/m}^2 \cdot \text{K}^4 [(400 \text{ K})^4 - (300 \text{ K})^4] = 1995 \text{ W.} <$$

(b) For diffuse-gray surface behavior, it follows from Eq. 13.26

$$q_{12} = \frac{\sigma A_1 (T_1^4 - T_2^4)}{\frac{1}{\epsilon_1} + \frac{1 - \epsilon_2}{\epsilon_2} \left(\frac{r_1}{r_2}\right)^2} = \frac{5.67 \times 10^{-8} \text{ W/m}^2 \cdot \text{K}^4 \pi (0.8 \text{ m})^2 [400^4 - 300^4] \text{ K}^4}{\frac{1}{0.5} + \frac{1 - 0.05}{0.05} \left(\frac{0.4}{0.6}\right)^2} = 191 \text{ W.} <$$

(c) With  $D_2 = 20 \text{ m}$ , it follows that

$$q_{12} = \frac{5.67 \times 10^{-8} \text{ W/m}^2 \cdot \text{K} \pi (0.8 \text{ m})^2 [(400 \text{ K})^4 - (300 \text{ K})^4]}{\frac{1}{0.5} + \frac{1 - 0.05}{0.05} \left(\frac{0.4}{10}\right)^2} = 983 \text{ W.} <$$

With  $\epsilon_2 = 1$ , instead of 0.05, Eq. 13.21 reduces

$$q_{12} = \sigma A_1 \epsilon_1 (T_1^4 - T_2^4) = 5.67 \times 10^{-8} \text{ W/m}^2 \cdot \text{K}^4 \pi (0.8 \text{ m})^2 0.5 [(400 \text{ K})^4 - (300 \text{ K})^4] = 998 \text{ W.} <$$

Continued ...



### PROBLEM 13.55 (Cont.)

(d) Using the *IHT Radiation* Tool Pad, the following results were obtained

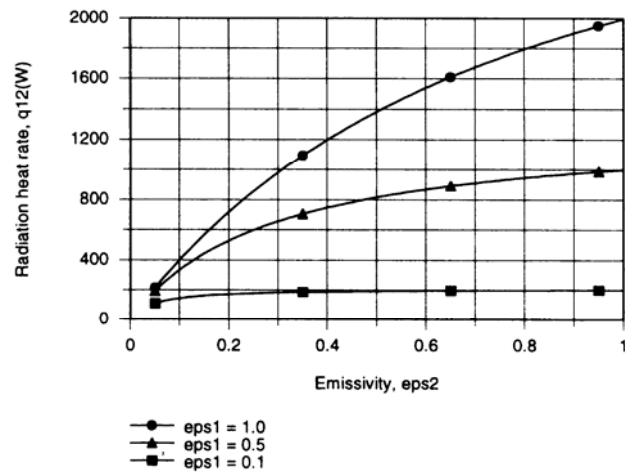

Net radiation exchange increases with  $\epsilon_1$  and  $\epsilon_2$ , and the trends are due to increases in emission from and absorption by surfaces 1 and 2, respectively.

**COMMENTS:** From part (c) it is evident that the actual surface emissivity of a *large* enclosure has a small effect on radiation exchange with small surfaces in the enclosure. Working with  $\epsilon_2 = 1.0$  instead of  $\epsilon_2 = 0.05$ , the value of  $q_{12}$  is increased by only  $(998 - 983)/983 = 1.5\%$ . In contrast, from the results of (d) it is evident that the surface emissivity  $\epsilon_2$  of a *small* enclosure has a large effect on radiation exchange with interior objects, which increases with increasing  $\epsilon_1$ .

### PROBLEM 13.56

**KNOWN:** Two radiation shields positioned in the evacuated space between two infinite, parallel planes.

**FIND:** Steady-state temperature of the shields.

**SCHEMATIC:**

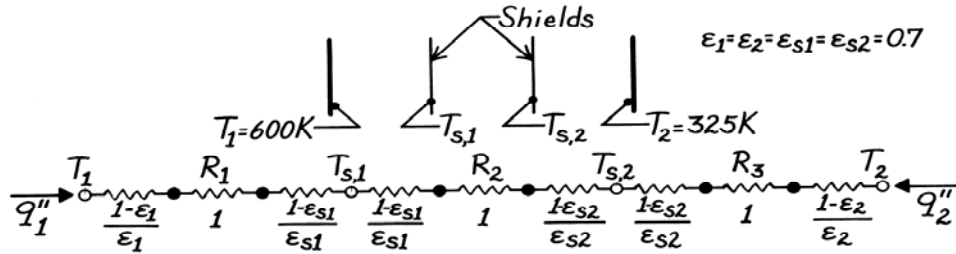

**ASSUMPTIONS:** (1) All surfaces are diffuse-gray and (2) All surfaces are parallel and of infinite extent.

**ANALYSIS:** The planes and shields can be represented by a thermal circuit from which it follows that

$$q_1'' = -q_2'' = \frac{\sigma(T_1^4 - T_2^4)}{R_1'' + R_2'' + R_3''} = \frac{\sigma(T_1^4 - T_{s1}^4)}{R_1''} = \frac{\sigma(T_{s1}^4 - T_{s2}^4)}{R_2''} = \frac{\sigma(T_{s2}^4 - T_2^4)}{R_3''}.$$

Since all the emissivities involved are equal,  $R_1'' = \frac{A_1}{A_1 F_{12}} = 1 = R_2'' = R_3''$ , so that

$$T_{s1}^4 = T_1^4 - \frac{R_1''}{R_1'' + R_2'' + R_3''} (T_1^4 - T_2^4) = T_1^4 - (1/3)(T_1^4 - T_2^4)$$

$$T_{s1}^4 = (600 \text{ K})^4 - (1/3)(600^4 - 325^4) \text{ K}^4 \quad T_{s1} = 548 \text{ K} \quad <$$

$$T_{s2}^4 = T_2^4 + \frac{R_3''}{R_1'' + R_2'' + R_3''} (T_1^4 - T_2^4) = T_2^4 + (1/3)(T_1^4 - T_2^4)$$

$$T_{s2}^4 = (325 \text{ K})^4 + (1/3)(600^4 - 325^4) \text{ K}^4 \quad T_{s2} = 474 \text{ K} \quad <$$

### PROBLEM 13.57

**KNOWN:** Two large, infinite parallel plates that are diffuse-gray with temperatures and emissivities of  $T_1$  and  $\varepsilon_1$  and  $T_2$  and  $\varepsilon_2$ .

**FIND:** Show that the ratio of the radiation transfer rate with multiple shields,  $N$ , of emissivity  $\varepsilon_s$  to that with no shields,  $N = 0$ , is

$$\frac{q_{12,N}}{q_{12,0}} = \frac{[1/\varepsilon_1 + 1/\varepsilon_2 - 1]}{[1/\varepsilon_1 + 1/\varepsilon_2 - 1] + N[2/\varepsilon_s - 1]}$$

where  $q_{12,N}$  and  $q_{12,0}$  represent the radiation heat rate with  $N$  and  $N = 0$  shields, respectively.

**SCHEMATIC:**

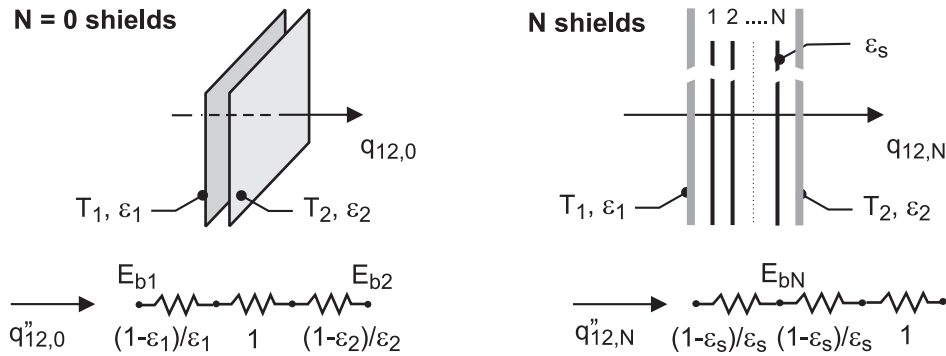

**ASSUMPTIONS:** (1) Plane infinite planes with diffuse-gray surfaces and uniform radiosities, and (2) Shield has negligible thermal conduction resistance.

**ANALYSIS:** Representing the parallel plates by the resistance network shown above for the “no-shield” condition,  $N = 0$ , with  $F_{12} = 1$ , the heat rate per unit area follows from Eq. 13.24 (see also Fig. 13.11) as

$$q''_{12,0} = \frac{E_{b1} - E_{b2}}{1/\varepsilon_1 + 1/\varepsilon_2 - 1} \quad (1)$$

With the addition of each shield as shown in the schematic above, three resistance elements are added to the network: two surface resistances,  $(1 - \varepsilon_s)/\varepsilon_s$ , and one space resistance,  $1/F_{ij} = 1$ . Hence, for the “ $N$  - shield” condition,

$$q''_{12,N} = \frac{E_{b1} - E_{b2}}{[1/\varepsilon_1 + 1/\varepsilon_2 - 1] + N[2(1 - \varepsilon_s)/\varepsilon_s + 1]} \quad (2)$$

The ratio of the heat rates is obtained by dividing Eq. (2) by Eq. (1),

$$\frac{q''_{12,N}}{q_{12,0}} = \frac{[1/\varepsilon_1 + 1/\varepsilon_2 - 1]}{[1/\varepsilon_1 + 1/\varepsilon_2 - 1] + N[2/\varepsilon_s - 1]} \quad <$$

**COMMENTS:** Can you derive an expression to determine the temperature difference across pairs of the  $N$ -shields?

### PROBLEM 13.58

**KNOWN:** Emissivities of two large, parallel surfaces.

**FIND:** Heat shield emissivity needed to reduce radiation transfer by a factor of 10.

**SCHEMATIC:**

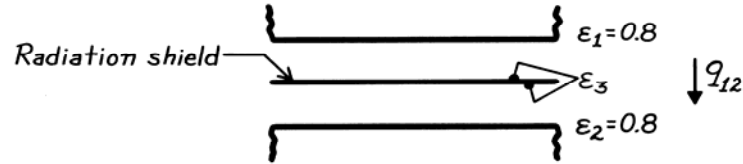

**ASSUMPTIONS:** (a) Diffuse-gray surface behavior, (b) Negligible conduction resistance for shield, (c) Same emissivity on opposite sides of shield.

**ANALYSIS:** For this arrangement,  $F_{13} = F_{32} = 1$ .

Without (wo) the shield, it follows from Eq. 13.24,

$$(q_{12})_{wo} = \frac{A_1 \sigma (T_1^4 - T_2^4)}{\frac{1}{\epsilon_1} + \frac{1}{\epsilon_2} - 1}$$

With (w) the shield it follows from Eq. 13.28,

$$(q_{12})_w = \frac{A_1 \sigma (T_1^4 - T_2^4)}{\frac{1}{\epsilon_1} + \frac{1}{\epsilon_2} + \frac{2}{\epsilon_3} - 2}$$

Hence, the heat rate ratio is

$$\frac{(q_{12})_w}{(q_{12})_{wo}} = 0.1 = \frac{\frac{1}{\epsilon_1} + \frac{1}{\epsilon_2} - 1}{\frac{1}{\epsilon_1} + \frac{1}{\epsilon_2} + \frac{2}{\epsilon_3} - 2} = \frac{\frac{1}{0.8} + \frac{1}{0.8} - 1}{\frac{1}{0.8} + \frac{1}{0.8} + \frac{2}{\epsilon_3} - 2}$$

Solving, find

$$\epsilon_3 = 0.138.$$

<

**COMMENTS:** The foregoing result is independent of  $T_1$  and  $T_2$ . It is only necessary that the temperatures be maintained at fixed values, irrespective of whether or not the shield is in place.

### PROBLEM 13.59

**KNOWN:** Surface emissivities of a radiation shield inserted between parallel plates of prescribed temperatures and emissivities.

**FIND:** (a) Effect of shield orientation on radiation transfer, (b) Effect of shield orientation on shield temperature.

**SCHEMATIC:**

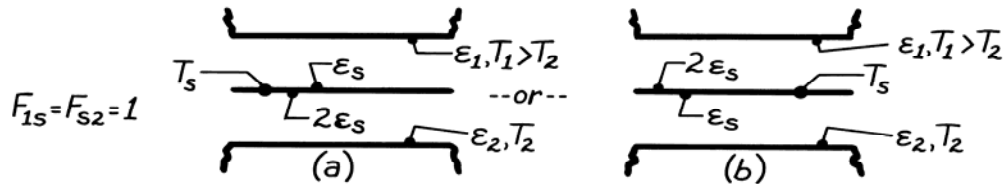

**ASSUMPTIONS:** (1) Diffuse-gray surface behavior, (2) Shield is isothermal.

**ANALYSIS:** (a) On a unit area basis, the network representation of the system is

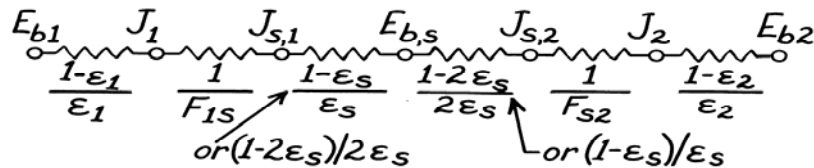

Hence the total radiation resistance,

$$R = \frac{1-\varepsilon_1}{\varepsilon_1} + 1 + \frac{1-\varepsilon_s}{\varepsilon_s} + \frac{1-2\varepsilon_s}{2\varepsilon_s} + 1 + \frac{1-\varepsilon_2}{\varepsilon_2}$$

is independent of orientation. Since  $q = (E_{b1} - E_{b2})/R$ , the heat transfer rate is independent of orientation.

(b) Considering that portion of the circuit between  $E_{b1}$  and  $E_{b,s}$ , it follows that

$$q = \frac{E_{b1} - E_{b,s}}{\frac{1-\varepsilon_1}{\varepsilon_1} + 1 + f(\varepsilon_s)}, \text{ where } f(\varepsilon_s) = \frac{1-\varepsilon_s}{\varepsilon_s} \text{ or } \frac{1-2\varepsilon_s}{2\varepsilon_s}.$$

Hence,

$$E_{b,s} = E_{b1} - \left[ \frac{1-\varepsilon_1}{\varepsilon_1} + 1 + f(\varepsilon_s) \right] q.$$

It follows that, since  $E_{b,s}$  increases with decreasing  $f(\varepsilon_s)$  and  $(1-2\varepsilon_s)/2\varepsilon_s < (1-\varepsilon_s)/\varepsilon_s$ ,  $E_{b,s}$  is larger when the high emissivity ( $2\varepsilon_s$ ) side faces plate 1. Hence  $T_s$  is larger for case (b). <

### PROBLEM 13.60

**KNOWN:** End of propellant tank with radiation shield is subjected to solar irradiation in space environment.

**FIND:** (a) Temperature of the shield,  $T_s$ , and (b) Heat flux to the tank,  $q_1''$  ( $\text{W}/\text{m}^2$ ).

**SCHEMATIC:**

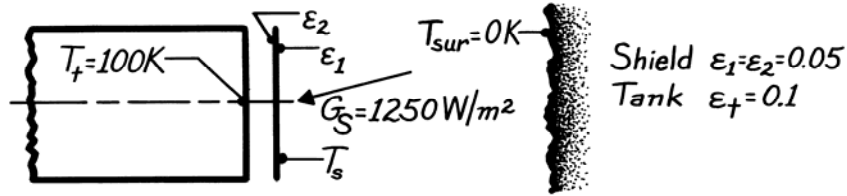

**ASSUMPTIONS:** (1) All surfaces are diffuse-gray, (2) View factor between shield and tank is unity,  $F_{st} = 1$ , (3) Space surroundings are black at 0 K, (4) Resistance of shield for conduction is negligible.

**ANALYSIS:** (a) Perform a radiation balance on the shield. From the schematic,

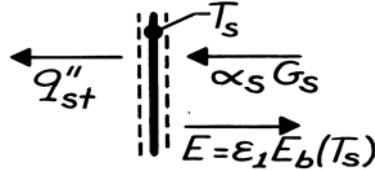

$$\alpha_S G_S - \epsilon_1 E_b(T_s) - q''_{st} = 0 \quad (1)$$

where  $q''_{st}$  is the net heat exchange between the shield and the tank. Considering these two surfaces as large, parallel planes, from Eq. 13.24,

$$q''_{st} = \sigma (T_s^4 - T_t^4) / [1/\epsilon_2 + 1/\epsilon_1 - 1]. \quad (2)$$

Substituting  $q''_{st}$  from Eq. (2) into Eq. (1), find

$$\alpha_S G_S - \epsilon_1 \sigma T_s^4 - \sigma (T_s^4 - T_t^4) / [1/\epsilon_2 + 1/\epsilon_1 - 1] = 0.$$

Solving for  $T_s$ , find

$$T_s = \left[ \frac{\alpha_S G_S + \sigma T_t^4 / [1/\epsilon_2 + 1/\epsilon_1 - 1]}{\sigma (\epsilon_1 + 1 / [1/\epsilon_2 + 1/\epsilon_1 - 1])} \right]^{1/4}.$$

Since the shield is diffuse-gray,  $\alpha_S = \epsilon_1$  and then

$$T_s = \left[ \frac{0.05 \times 1250 \text{ W/m}^2 + \sigma (100)^4 \text{ K}^4 / [1/0.05 + 1/0.1 - 1]}{\sigma (0.05 + 1 / [1/0.05 + 1/0.1 - 1])} \right]^{1/4} = 338 \text{ K.} \quad <$$

(b) The heat flux to the tank can be determined from Eq. (2),

$$q''_{st} = 5.67 \times 10^{-8} \text{ W/m}^2 \cdot \text{K}^4 (338^4 - 100^4) \text{ K}^4 / [1/0.05 + 1/0.1 - 1] = 25.3 \text{ W/m}^2. \quad <$$

### PROBLEM 13.61

**KNOWN:** Black panel at 77 K in large vacuum chamber at 300 K with radiation shield having  $\epsilon = 0.05$ .

**FIND:** Net heat transfer by radiation to the panel.

**SCHEMATIC:**

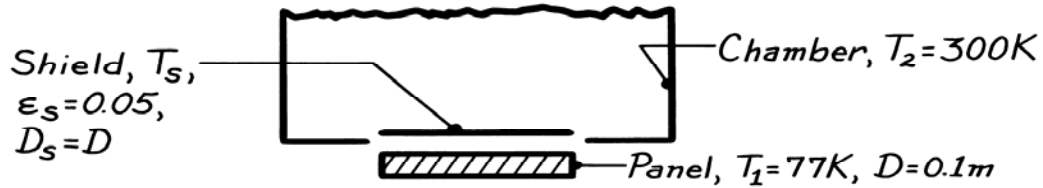

**ASSUMPTIONS:** (1) Chamber is large compared to shield, (2) Shape factor between shield and plate is unity, (3) Shield is diffuse-gray, (4) Shield is thin, negligible thermal conduction resistance.

**ANALYSIS:** The arrangement lends itself to a network representation following Figs. 13.10 and 13.11.

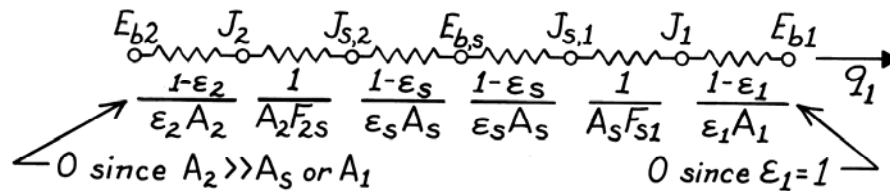

Noting that  $F_{2s} = F_{s1} = 1$ , and that  $A_2 F_{2s} = A_s F_{s1}$ , the heat rate is

$$q_1 = (E_{b2} - E_{b1}) / \Sigma R_i = \sigma (T_2^4 - T_1^4) / \left[ \frac{1}{A_s} + 2 \left( \frac{1 - \epsilon_s}{\epsilon_s A_s} \right) + \frac{1}{A_s} \right].$$

Recognizing that  $A_s = A_1$  and multiplying numerator and denominator by  $A_1$  gives

$$q_1 = A_1 \sigma (T_2^4 - T_1^4) \left[ 2 + 2 \left( \frac{1 - \epsilon_s}{\epsilon_s} \right) \right].$$

Substituting numerical values, find

$$q_1 = \frac{\pi (0.1)^2 \text{ m}^2}{4} \times 5.67 \times 10^{-8} \text{ W/m}^2 \cdot \text{K}^4 (300^4 - 77^4) \text{ K}^4 / \left[ 2 + 2 \left( \frac{1 - 0.05}{0.05} \right) \right]$$

$$q_1 = 89.8 \text{ mW.} \quad \leftarrow$$

**COMMENTS:** In using the network representation, be sure to designate direction of the net heat rate. In this situation, we have shown  $q_1$  as the net rate *into* the surface  $A_1$ . The temperature of the shield,  $T_s = 253 \text{ K}$ , follows from the relation

$$q_1 = (E_{bs} - E_{b1}) / \left[ \frac{1 - \epsilon_s}{\epsilon_s A_s} + \frac{1}{A_1 F_{s1}} \right].$$

### PROBLEM 13.62

**KNOWN:** Dense cryogenic piping array located close to furnace wall.

**FIND:** Number of radiation shields,  $N$ , to be installed such that the temperature of the shield closest to the array,  $T_{s,N}$ , is less than  $30^\circ\text{C}$ .

**SCHEMATIC:**

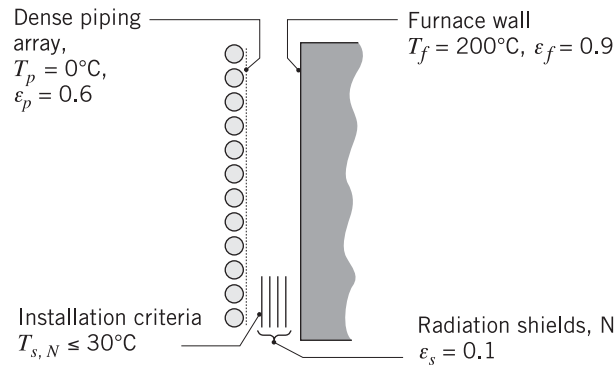

**ASSUMPTIONS:** (1) The ice-covered dense piping array approximates a plane surface, (2) Piping array and furnace wall can be represented by infinite parallel plates, (3) Surfaces are diffuse-gray, and (4) Convection effects are negligible.

**ANALYSIS:** Treating the piping array and furnace wall as infinite parallel plates, the net heat rate by radiation exchange with  $N$  shields of identical emissivity,  $\epsilon_s$ , on both sides follows from extending the network of Fig. 13.12 to account for the resistances of  $N$  shields. (See Problem 13.57) For each shield added, two surface resistances and one space resistance are added,

$$q_{fp} = \frac{\sigma(T_f^4 - T_p^4)A_f}{\left[1/\epsilon_f + 1/\epsilon_p - 1\right] + N\left[2/\epsilon_s - 1\right]} \quad (1)$$

where  $\sigma = 5.67 \times 10^{-8} \text{ W/m}^2 \cdot \text{K}^4$ . The requirement that the  $N$ -th shield (next to the piping array) has a temperature  $T_{s,N} \leq 30^\circ\text{C}$  will be satisfied when

$$q_{fp} \leq \frac{\sigma(T_{s,N}^4 - T_p^4)A_f}{\left[1/\epsilon_s + 1/\epsilon_p - 1\right]} \quad (2)$$

Using the foregoing equations in the *IHT* workspace, find that  $T_{s,N} = 30^\circ\text{C}$  when  $N = 8.60$ . So that  $T_{s,N}$  is less than  $30^\circ\text{C}$ , the number of shields required is

$$N = 9$$

<

**COMMENTS:** Note that when  $N = 0$ , Eq. (1) reduces to the case of two parallel plates. Show for the case with one shield,  $N = 1$ , that Eq. (1) is identical to Eq. 13.28.



### PROBLEM 13.63

**KNOWN:** Concentric tube arrangement with diffuse-gray surfaces.

**FIND:** (a) Heat gain by the cryogenic fluid per unit length of the inner tube (W/m), (b) Change in heat gain if diffuse-gray shield with  $\epsilon_s = 0.02$  is inserted midway between inner and outer surfaces.

**SCHEMATIC:**

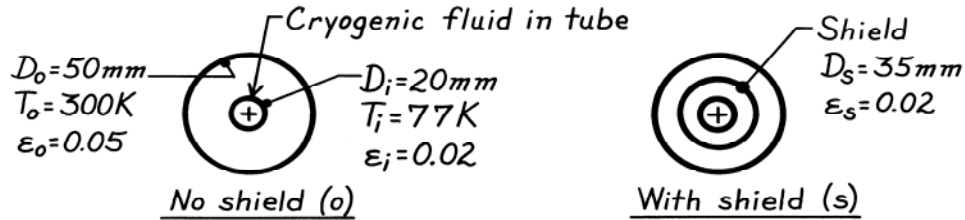

**ASSUMPTIONS:** (1) Surfaces are diffuse-gray, (2) Space between tubes is evacuated.

**ANALYSIS:** (a) For the *no shield* case, the thermal circuit is shown at right. It follows that the net heat gain per unit tube length is

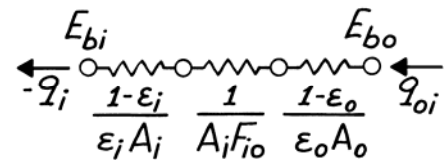

$$-q'_1 = \frac{q_{oi}}{L} = (E_{bo} - E_{bi}) / \left[ \frac{1 - \epsilon_o}{\epsilon \pi D_o} + \frac{1}{\pi D_i F_{i0}} + \frac{1 - \epsilon_i}{\epsilon_i \pi D_i} \right]$$

where  $A = \pi DL$ . Note that  $F_{i0} = 1$  and  $E_b = \sigma T^4$  giving

$$-q'_1 = 5.67 \times 10^{-8} \text{ W/m}^2 \cdot \text{K}^4 \left( 300^4 - 77^4 \right) \text{ K}^4 / \left[ \frac{1 - 0.05}{0.05 \pi \times 50 \times 10^{-3}} + \frac{1}{\pi 20 \times 10^{-3} \times 1} + \frac{1 - 0.02}{0.02 \pi \times 20 \times 10^{-3}} \right] \text{ m}^{-1}$$

$$-q'_1 = 457 \text{ W/m}^2 / [121.0 + 15.9 + 779.8] \text{ m}^{-1} = 0.501 \text{ W/m.} \quad <$$

(b) For the *with shield* case, the thermal circuit will include three additional resistances.

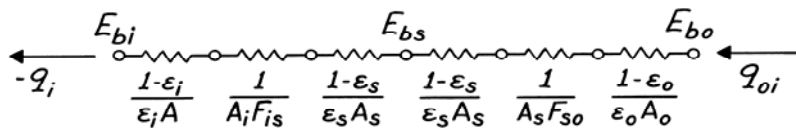

From the network, it follows that  $-q_i = (E_{bo} - E_{bi}) / \Sigma R_t$ . With  $F_{is} = F_{so} = 1$ , find

$$-q'_1 = 457 \text{ W/m}^2 / \left[ 121.0 + \frac{1}{\pi 35 \times 10^{-3} \times 1} + \frac{2(1 - 0.02)}{0.02 \pi 35 \times 10^{-3}} + 15.9 + 779.8 \right] \text{ m}^{-1}$$

$$-q'_1 = 457 \text{ W/m}^2 / [121.0 + 9.1 + 891.3 + 15.9 + 779.8] \text{ m}^{-1} = 0.251 \text{ W/m.}$$

The change (percentage) in heat gain per unit length of the tube as a result of inserting the radiation shield is

$$\frac{q'_{i,s} - q'_{i,ns}}{q'_{i,ns}} \times 100 = \frac{(0.251 - 0.501) \text{ W/m}}{0.501 \text{ W/m}} \times 100 = -49\%. \quad <$$

### PROBLEM 13.64

**KNOWN:** Heated tube with radiation shield whose exterior surface is exposed to convection and radiation processes.

**FIND:** Operating temperature for the tube under the prescribed conditions.

**SCHEMATIC:**

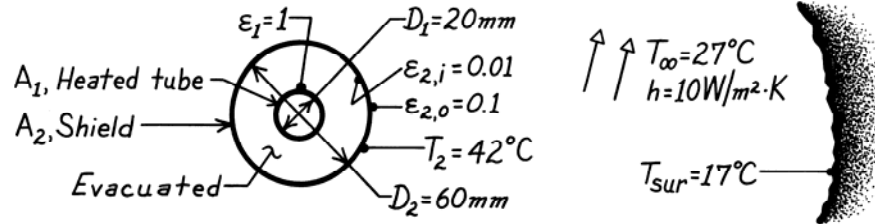

**ASSUMPTIONS:** (1) Steady-state conditions, (2) No convection in space between tube and shield, (3) Surroundings are large compared to the shield and are isothermal, (4) Tube and shield are infinitely long, (5) Surfaces are diffuse-gray, (6) Shield is isothermal.

**ANALYSIS:** Perform an energy balance on the shield.

$$\dot{E}_{\text{in}} - \dot{E}_{\text{out}} = 0$$

$$q_{12} - q_{\text{conv}} - q_{\text{rad}} = 0$$

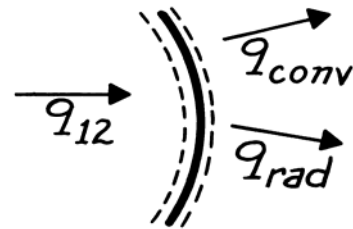

where  $q_{12}$  is the net radiation exchange between the tube and inner surface of the shield, which from Eq. 13.25 is,

$$-q_{12} = \frac{A_1 \sigma (T_1^4 - T_2^4)}{\frac{1}{\epsilon_1} + \frac{1 - \epsilon_{2,i}}{\epsilon_{2,i}} \frac{D_1}{D_2}}$$

Using appropriate rate equations for  $q_{\text{conv}}$  and  $q_{\text{rad}}$ , the energy balance is

$$\frac{A_1 \sigma (T_1^4 - T_2^4)}{1 + \frac{1 - \epsilon_{2,i}}{\epsilon_{2,i}} \frac{D_1}{D_2}} - h A_2 (T_2 - T_\infty) - \epsilon_{2,o} A_2 \sigma (T_2^4 - T_{\text{sur}}^4) = 0$$

where  $\epsilon_1 = 1$ . Substituting numerical values, with  $A_1/A_2 = D_1/D_2$ , and solving for  $T_1$ ,

$$\frac{(20/60) \times 5.67 \times 10^{-8} \text{ W/m}^2 \cdot \text{K}^4 (T_1^4 - 315^4) \text{ K}^4}{1 + (1 - 0.01/0.01)(20/60)} - 10 \text{ W/m}^2 \cdot \text{K} (315 - 300) \text{ K} - 0.1 \times 5.67 \times 10^{-8} \text{ W/m}^2 \cdot \text{K}^4 (315^4 - 290^4) \text{ K}^4 = 0$$

$$T_1 = 745 \text{ K} = 472^\circ\text{C}.$$

<

**COMMENTS:** Note that all temperatures are expressed in kelvins. This is a necessary practice when dealing with radiation and convection modes.

### PROBLEM 13.65

**KNOWN:** Cylindrical-shaped, three surface enclosure with lateral surface insulated.

**FIND:** Temperatures of the lower plate  $T_1$  and insulated side surface  $T_3$ .

**SCHEMATIC:**

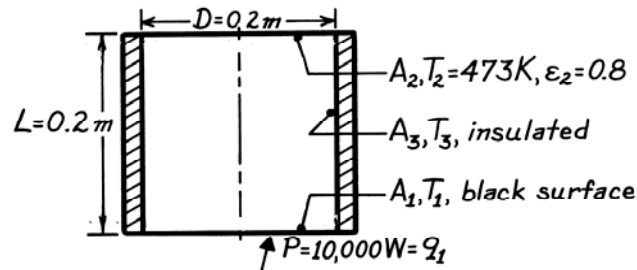

**ASSUMPTIONS:** (1) Surfaces have uniform radiosity or emissive power, (2) Upper and insulated surfaces are diffuse-gray, (3) Negligible convection.

**ANALYSIS:** Find the temperature of the lower plate  $T_1$  from Eq. 13.30

$$q_1 = \frac{\sigma(T_1^4 - T_2^4)}{(1 - \varepsilon_1) / \varepsilon_1 A_1 + \left[ A_1 F_{12} + \left[ (1 / A_1 F_{13}) + (1 / A_2 F_{23}) \right]^{-1} \right]^{-1} + (1 - \varepsilon_2) / \varepsilon_2 A_2} \quad (1)$$

From Table 13.2 for parallel coaxial disks,

$$R_1 = r_1 / L = 0.1 / 0.2 = 0.5$$

$$R_2 = r_2 / L = 0.1 / 0.2 = 0.5$$

$$S = 1 + \left( 1 + R_2^2 \right) / R_1^2 = 1 + \left( 1 + 0.5^2 \right) / 0.5^2 = 6.0$$

$$F_{12} = 1/2 \left\{ S - \left[ S^2 - 4(r_2 / r_1)^2 \right]^{1/2} \right\} = 1/2 \left\{ 6 - \left[ 6^2 - 4(0.5/0.5)^2 \right]^{1/2} \right\} = 0.172.$$

Using the summation rule for the enclosure,  $F_{13} = 1 - F_{12} = 1 - 0.172 = 0.828$ , and from symmetry,  $F_{23} = F_{13}$ . With  $A_1 = A_2 = \pi D^2 / 4 = \pi(0.2 \text{ m})^2 / 4 = 0.03142 \text{ m}^2$  and substituting numerical values into Eq. (1), obtain

$$10,000 \text{ W} = \frac{0.03142 \text{ m}^2 \times 5.67 \times 10^{-8} \text{ W/m}^2 \cdot \text{K}^4 \left( T_1^4 - 473^4 \right) \text{ K}^4}{0 + \left[ 0.172 + \left[ (1 / 0.828) + (1 / 0.172) \right]^{-1} \right]^{-1} + (1 - 0.8) / 0.8}$$

$$10,000 = 4.540 \times 10^9 \left( T_1^4 - 473^4 \right) \quad T_1 = 1225 \text{ K.} \quad <$$

The temperature of the insulated side surface can be determined from the radiation balance, Eq. 13.31, with  $A_1 = A_2$ ,

$$\frac{J_1 - J_3}{1 / F_{13}} - \frac{J_3 - J_2}{1 / F_{23}} = 0 \quad (2)$$

where  $J_1 = \sigma T_1^4$  and  $J_2$  can be evaluated from Eq. 13.19,

Continued ...

**PROBLEM 13.65 (Cont.)**

$$q_2 = \frac{E_{b2} - J_2}{(1 - \varepsilon_2) / \varepsilon_2 A_2} \quad -10,000 \text{ W} = \frac{5.67 \times 10^{-8} \text{ W/m}^2 \cdot \text{K}^4 (473 \text{ K})^4 - J_2}{(1 - 0.8) / (0.8 \times 0.03142 \text{ m}^2)}$$

find  $J_2 = 82,405 \text{ W/m}^2$ . Substituting numerical values into Eq. (2),

$$\frac{5.67 \times 10^{-8} \text{ W/m}^2 \cdot \text{K}^4 (1225 \text{ K})^4 - J_3}{1/0.172} - \frac{J_3 - 82,405 \text{ W/m}^2}{1/0.172} = 0$$

find  $J_3 = 105,043 \text{ W/m}^2$ . Hence, for this insulated, re-radiating (adiabatic) surface,

$$E_{b3} = \sigma T_3^4 = 105,043 \text{ W/m}^2$$

$$T_3 = 1167 \text{ K.}$$

<

### PROBLEM 13.66

**KNOWN:** Furnace in the form of a truncated conical section, floor (1) maintained at  $T_1 = 1000 \text{ K}$  by providing a heat flux  $q''_{1,\text{in}} = 2200 \text{ W/m}^2$ ; lateral wall (3) perfectly insulated; radiative properties of all surfaces specified.

**FIND:** (a) Temperature of the upper surface,  $T_2$ , and of the lateral wall  $T_3$ , and (b)  $T_2$  and  $T_3$  if all the furnace surfaces are black instead of diffuse-gray, with all other conditions remain unchanged.

Explain effect of  $\varepsilon_2$  on your results.

**SCHEMATIC:**

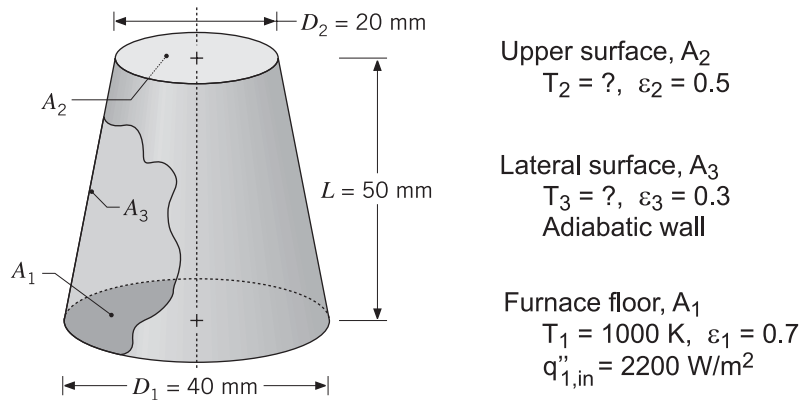

**ASSUMPTIONS:** (1) Furnace is a three-surface, diffuse-gray enclosure, (2) Surfaces have uniform radiosities, (3) Lateral surface is adiabatic, and (4) Negligible convection effects.

**ANALYSIS:** For the three-surface enclosure, write the radiation surface energy balances, Eq. 13.21, to find the radiosities of the three surfaces.

$$\frac{E_{b,1} - J_1}{(1 - \varepsilon_1) / \varepsilon_1 A_1} = \frac{J_1 - J_2}{1/A_1 F_{12}} + \frac{J_1 - J_3}{1/A_1 F_{13}} \quad (1)$$

$$\frac{E_{b,2} - J_2}{(1 - \varepsilon_2) / \varepsilon_2 A_2} = \frac{J_2 - J_1}{1/A_2 F_{21}} + \frac{J_2 - J_3}{1/A_2 F_{23}} \quad (2)$$

$$\frac{E_{b,3} - J_3}{(1 - \varepsilon_3) / \varepsilon_3 A_3} = \frac{J_3 - J_1}{1/A_3 F_{31}} + \frac{J_3 - J_2}{1/A_3 F_{32}} \quad (3)$$

where the blackbody emissive powers are of the form  $E_b = \sigma T^4$  with  $\sigma = 5.67 \times 10^{-8} \text{ W/m}^2 \cdot \text{K}^4$ . From Eq. 13.19, the net radiation leaving  $A_1$  is

$$q_1 = \frac{E_{b,1} - J_1}{(1 - \varepsilon_1) / \varepsilon_1 A_1} \quad (4)$$

$$q_1 = q''_{1,\text{in}} \cdot A_1 = 2200 \text{ W/m}^2 \times \pi(0.040 \text{ m})^2 / 4 = 2.76 \text{ W}$$

Continued ...

### PROBLEM 13.66 (Cont.)

Since the lateral surface is adiabatic,

$$q_3 = \frac{E_{b,3} - J_3}{(1 - \varepsilon_3) / \varepsilon_3 A_3} = 0 \quad (5)$$

from which we recognize  $E_{b,3} = J_3$ , but will find that as an outcome of the analysis. For the enclosure,  $N = 3$ , there are  $N^2 = 9$  view factors, for which  $N(N - 1)/2 = 3$  must be directly determined.

Calculations for the  $F_{ij}$  are summarized in Comments.

With the foregoing five relations, we can determine the five unknowns:  $J_1$ ,  $J_2$ ,  $J_3$ ,  $E_{b,2}$ , and  $E_{b,3}$ . The temperatures  $T_2$  and  $T_3$  will be evaluated from the relation  $E_b = \sigma T^4$ . Using this analysis approach with the relations in the *IHT* workspace, the results for (a) the diffuse-gray surfaces and (b) black surfaces are tabulated below. <

	$J_1$ (kW/m <sup>2</sup> )	$J_2$ (kW/m <sup>2</sup> )	$J_3$ (kW/m <sup>2</sup> )	$T_2$ (K)	$T_3$ (K)
(a) Diffuse-gray	55.76	45.30	53.48	896	986
(b) Black	56.70	46.24	54.42	950	990

**COMMENTS:** (1) From the tabulated results, it follows that the temperatures of the lateral and top surfaces will be higher when the surfaces are black, rather than diffuse-gray as specified.

(2) From Eq. (5) for the net heat radiation leaving the lateral surface,  $A_3$ , the rate is zero since the wall is adiabatic. The consequences are that the blackbody emissive power and the radiosity are equal, and that the emissivity of the surface has no effect in the analysis. That is, this surface emits and absorbs at the same rate; the net is zero.

(3) For the enclosure,  $N = 3$ , there are  $N^2 = 9$  view factors, for which

$$N(N - 1)/2 = 3 \times 2 / 2 = 3$$

must be directly determined. We used the *IHT Tools | Radiation | View Factors Relations* model that sets up the summation rules and reciprocity relations for the  $N$  surfaces. The user is required to specify the 3  $F_{ij}$  that must be determined directly; by inspection,  $F_{11} = F_{22} = 0$ ; and  $F_{12}$  can be evaluated using the parallel coaxial disk relation, Table 13.2 (Fig. 13.5). This model is also provided in *IHT* to simplify the calculation task. The results of the view factor analysis are:

$$F_{12} = 0.03348 \qquad F_{13} = 0.9665$$

$$F_{21} = 0.1339 \qquad F_{23} = 0.8661$$

(4) An alternative method of solution for part (a) is to treat the enclosure of part (a) as described in Section 13.3.5. For part (b), the black enclosure analysis is described in Section 13.2. We chose to use the direct approach, Section 13.3.2, to develop a general 3-surface enclosure code in *IHT* that can also handle black surfaces (caution: use  $\varepsilon = 0.999$ , not 1.000).

### PROBLEM 13.67

**KNOWN:** Parallel, aligned discs located in a large room; one disk is insulated, the other is at a prescribed temperature.

**FIND:** Temperature of the insulated disc.

**SCHEMATIC:**

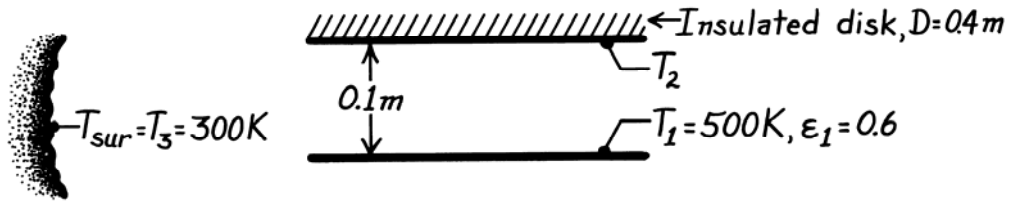

**ASSUMPTIONS:** (1) Surfaces are diffuse-gray, (2) Surroundings are large, with uniform temperature, behaving as a blackbody, (3) Negligible convection.

**ANALYSIS:** From an energy balance on surface  $A_2$ ,

$$q_2 = 0 = \frac{J_2 - J_1}{1/A_2 F_{21}} + \frac{J_2 - J_3}{1/A_2 F_{23}}. \quad (1)$$

Note that  $q_2 = 0$  since the surface is adiabatic. Since  $A_3$  is a blackbody,  $J_3 = E_{b3} = \sigma T_3^4$ ; since  $A_2$  is adiabatic,  $J_2 = E_{b2} = \sigma T_2^4$ . From Fig. 13.5 and the summation rule for surface  $A_1$ , find

$$F_{12} = 0.62 \text{ with } \frac{r_j}{L} = \frac{0.2}{0.1} = 2 \text{ and } \frac{L}{r_i} = \frac{0.1}{0.2} = 0.5, \quad F_{13} = 1 - F_{12} = 1 - 0.62 = 0.38.$$

Hence, Eq. (1) with  $J_3 = 5.67 \times 10^{-8} \times 300^4 \text{ W/m}^2$  becomes

$$\frac{J_2 - J_1}{1/A_2 \times 0.62} + \frac{J_2 - 459.3 \text{ W/m}^2}{1/A_2 \times 0.38} = 0 \quad -0.62J_1 + 1.00J_2 = 174.5 \quad (2,3)$$

The radiation balance on surface  $A_1$  with  $E_{b3} = 5.67 \times 10^{-8} \times 500^4 \text{ W/m}^2$  becomes

$$\frac{E_{b1} - J_1}{(1 - \epsilon_1)/\epsilon_1 A_1} = \frac{J_1 - J_2}{1/A_1 F_{12}} + \frac{J_1 - J_3}{1/A_1 F_{13}} \quad (4)$$

$$\frac{3543.8 - J_1}{(1 - 0.6)/0.6 A_1} = \frac{J_1 - J_2}{1/A_1 \times 0.62} + \frac{J_1 - 459.3}{1/A_1 \times 0.38} \quad 2.50J_1 - 0.62J_2 = 5490.2 \quad (5,6)$$

Solve Eqs. (3) and (6) to find  $J_2 = 1815 \text{ W/m}^2$  and since  $E_{b2} = J_2$ ,

$$T_2 = \left( \frac{E_{b2}}{\sigma} \right)^{1/4} = \left( \frac{1815 \text{ W/m}^2}{5.67 \times 10^{-8} \text{ W/m}^2 \cdot \text{K}^4} \right)^{1/4} = 423 \text{ K.} \quad <$$

**COMMENTS:** A network representation would help to visualize the exchange relations. However, it is useful to approach the problem by recognizing there are two unknowns in the problem:  $J_1$  and  $J_2$ ; hence two radiation balances must be written. Note also the significance of  $J_2 = E_{b2}$  and  $J_3 = E_{b3}$ .

### PROBLEM 13.68

**KNOWN:** Thermal conditions in oven used to cure strip coatings.

**FIND:** Electrical power requirement.

**SCHEMATIC:**

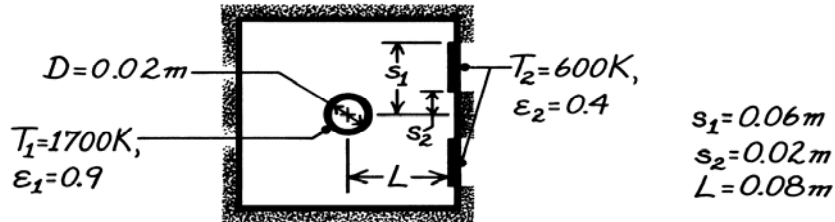

**ASSUMPTIONS:** (1) Diffuse-gray surfaces, (2) Furnace wall is reradiating, (3) Negligible end effects.

**ANALYSIS:** The net radiant power leaving the heater surface per unit length is

$$q'_1 = \frac{E_{b1} - E_{b2}}{\frac{1 - \epsilon_1}{\epsilon_1 A'_1} + \frac{1}{A'_1 F_{12} + \left[ \frac{1}{A_1 F_{1R}} + \frac{1}{A_2 F_{2R}} \right]^{-1}} + \frac{1 - \epsilon_2}{\epsilon_2 A'_2}}$$

where  $A'_1 = \pi D = \pi(0.02 \text{ m}) = 0.0628 \text{ m}$  and  $A'_2 = 2(s_1 - s_2) = 0.08 \text{ m}$ . The view factor between the heater and one of the strips is

$$F_{21} = \frac{D/2}{s_1 - s_2} \left[ \tan^{-1} \frac{s_1}{L} - \tan^{-1} \frac{s_2}{L} \right] = \frac{0.01}{0.04} \left[ \tan^{-1} \frac{0.06}{0.08} - \tan^{-1} \frac{0.02}{0.08} \right] = 0.10$$

and using the view factor relations find

$$A'_1 F_{12} = A'_2 F_{21} = 0.08 \text{ m} \times 0.10 = 0.008 \text{ m} \qquad F_{12} = (0.080 / 0.0628) 0.10 = 0.127$$

$$F_{1R} = 1 - F_{12} = 1 - 0.127 = 0.873 \qquad F_{2R} = 1 - F_{21} = 1 - 0.10 = 0.90.$$

Hence, with  $E_b = \sigma T^4$ ,

$$q'_1 = \frac{5.67 \times 10^{-8} \left[ (1700)^4 - (600)^4 \right]}{\frac{1 - 0.9}{0.9 \times 0.0628} + \frac{1}{0.008 + \left[ 1 / (0.0628 \times 0.873) + 1 / (0.08 \times 0.90) \right]^{-1}} + \frac{1 - 0.4}{0.4 \times 0.08}}$$

$$q'_1 = \frac{4.66 \times 10^5}{1.77 + 25.56 + 18.75} = 10,100 \text{ W/m.} \quad \leftarrow$$

**COMMENTS:** The radiosities for  $A_1$  and  $A_2$  follow from Eq. 13.19,

$$J_1 = E_{b1} - (1 - \epsilon_1) q'_1 / \epsilon_1 A'_1 = 4.56 \times 10^5 \text{ W/m}^2$$

$$J_2 = E_{b2} + (1 - \epsilon_2) q'_1 / \epsilon_2 A'_2 = 1.97 \times 10^5 \text{ W/m}^2.$$

From Eq. 13.31, find  $J_R$  and hence  $T_R$  as

$$0.0628 \times 0.873 (J_1 - J_R) - 0.08 \times 0.90 (J_R - J_2) = 0$$

$$J_R = 3.08 \times 10^5 \text{ W/m}^2 = \sigma T_R^4 \qquad T_R = 1527 \text{ K.}$$



### PROBLEM 13.69

**KNOWN:** Dimensions, temperature and emissivity of cylindrical product. Temperature and emissivity of infrared panel heater.

**FIND:** (a) Radiative flux delivered to the product and panel heat flux for a spacing of  $s = 100$  mm and a product length of  $L = 1$  m, (b) Plot of the heat flux experienced by the product, and the panel heater heat flux over the range  $50 \text{ mm} \leq s \leq 250$  mm.

**SCHEMATIC:**

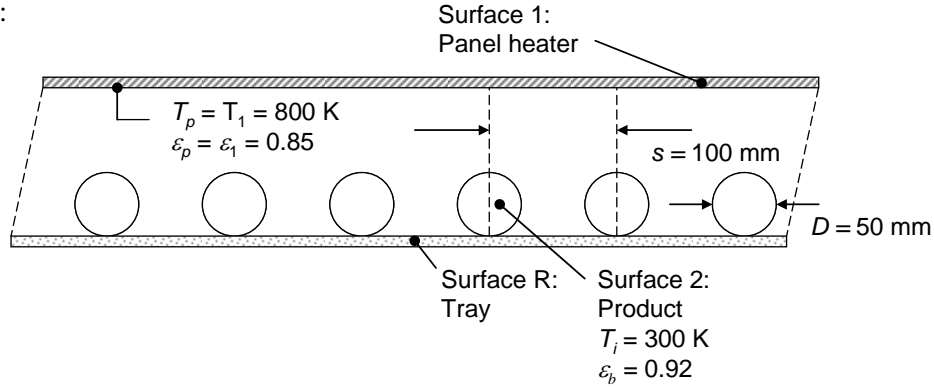

**ASSUMPTIONS:** (1) Diffuse-gray surfaces, (2) Negligible convection heat transfer.

**ANALYSIS:** (a) For the unit cell indicated in the schematic,  $A_1 = A_3 = A_R = s$  and  $A_2 = \pi D$ . From Eq. 13.30,

$$q_1 = -q_2 = \frac{E_{b1} - E_{b2}}{\frac{1 - \epsilon_1}{\epsilon_1 A_1} + \frac{1}{A_1 F_{12} + [(1/A_1 F_{1R}) + (1/A_2 F_{2R})]^{-1}} + \frac{1 - \epsilon_2}{\epsilon_2 A_2}}$$

Substituting the Stefan-Boltzmann equation and expressions for the unit surface areas, and dividing by  $A_2$  and using reciprocity in the form  $A_2 F_{2R} = A_R F_{R2}$ , the preceding expression may be written as

$$q_2'' = \frac{\sigma T_2^4 - \sigma T_1^4}{\frac{(1 - \epsilon_1)\pi D}{\epsilon_1 s} + \frac{\pi D}{s F_{12} + [(1/s F_{1R}) + (1/s F_{R2})]^{-1}} + \frac{1 - \epsilon_2}{\epsilon_2}} \quad (1)$$

The view factors are evaluated using the expression given in Table 13.1,

$$F_{R2} = F_{12} = 1 - \left[ 1 - \left( \frac{50}{100} \right)^2 \right]^{1/2} + \left( \frac{50}{100} \right) \tan^{-1} \left[ \left( \frac{100^2 - 50^2}{50^2} \right)^{1/2} \right] = 0.657 \quad (2)$$

$$\text{and } F_{1R} = 1 - F_{12} = 1 - 0.657 = 0.343. \quad (3)$$

Substituting into Eq. 1 yields

Continued...

### PROBLEM 13.69 (Cont.)

$$q_2'' = \frac{5.67 \times 10^{-8} \text{ W/m}^2 \cdot \text{K}^4 \times (300\text{K}^4 - 800\text{K}^4)}{\frac{(1-0.85) \times \pi \times 0.05\text{m}}{0.85 \times 0.10\text{m}} + \frac{\pi \times 0.05\text{m}}{0.10\text{m} \times 0.657 + [(1/0.10\text{m} \times 0.343) + (1/0.10\text{m} \times 0.657)]^{-1}} + \frac{1-0.92}{0.92}}$$

$$= -10,616 \text{ W/m}^2 \quad <$$

The panel heat flux is found by noting that

$$q_1 = -q_2 = q_1'' s L = -q_2'' \pi D L \quad \text{or} \quad q_1'' = -q_2'' \frac{\pi D}{s} = 10,616 \frac{\text{W}}{\text{m}^2} \times \frac{\pi \times 0.05\text{m}}{0.10\text{m}} = 16,680 \frac{\text{W}}{\text{m}^2} \quad <$$

(b) Using IHT, the radiation heat flux *from* the panel and the radiation heat flux *to* the product, as a function of the product spacing,  $s$ , is shown below. This was obtained by solving Eqs. 1 – 3 simultaneously. At small product spacing, the heat flux from the panel must be large in order to deliver radiation to the larger product surface area per unit width of the oven. At large product spacing, the product heat flux becomes large as more of the product is exposed to direct irradiation from the panel.

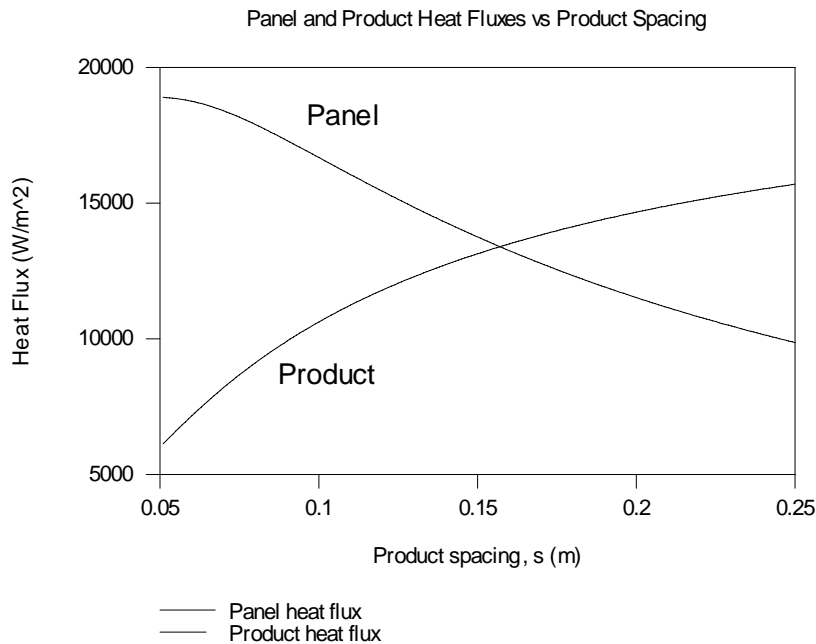

**COMMENTS:** (1) The product may be heated by a batch or a continuous process. (2) For a batch process, the product temperature would increase with time, with a faster increase in temperature associated with large product spacing. Of course, a smaller amount of total mass would be processed per unit time as the spacing is increased. Would an optimal product spacing, to maximize the product that is produced per unit time, exist? (3) For a continuous process, for example, if the product were placed on a reradiating conveyor tray, individual product would be heated faster at larger product spacing, but the amount of product that could be processed per unit time decreases with increased product spacing (for a given conveyor speed). Hence, a tradeoff would exist during continuous processing between the increased heating and decreased productivity as the product spacing is increased. Would an optimal product spacing, to maximize product throughput, exist?

### PROBLEM 13.70

**KNOWN:** Surface temperature and emissivity of molten alloy and distance of surface from top of container. Container diameter.

**FIND:** Net rate of radiation heat transfer from surface of melt.

**SCHEMATIC:**

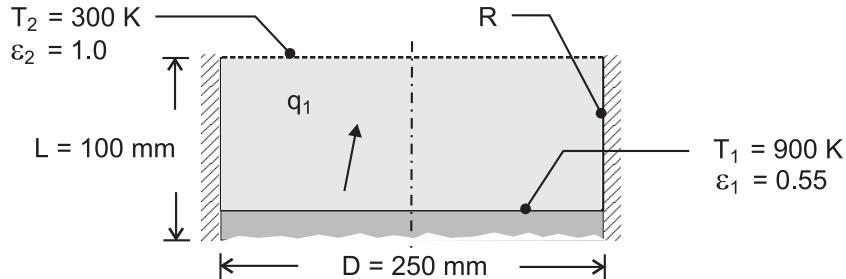

**ASSUMPTIONS:** (1) Opaque, diffuse, gray behavior for surface of melt, (2) Large surroundings may be represented by a hypothetical surface of temperature  $T = T_{\text{sur}}$  and  $\varepsilon = 1$ , (3) Negligible convection at exposed side wall, (4) Adiabatic side wall.

**ANALYSIS:** With negligible convection at an adiabatic side wall, the surface may be treated as reradiating. Hence, from Eq. 13.30, with  $A_1 = A_2$ ,

$$q_1 = \frac{A_1(E_{b1} - E_{b2})}{\frac{1 - \varepsilon_1}{\varepsilon_1} + \frac{1}{F_{12} + [(1/F_{1R}) + (1/F_{2R})]^{-1}} + \frac{1 - \varepsilon_2}{\varepsilon_2}}$$

With  $R_i = R_j = (D/2)/L = 1.25$  and  $S = \left[1 + \left(1 + R_j^2\right)/R_i^2\right] = 2.640$ , Table 13.2 yields

$$F_{12} = \frac{1}{2} \left\{ S - \left[ S^2 - 4(r_2/r_1)^2 \right]^{1/2} \right\} = 0.458$$

Hence,

$$F_{1R} = F_{2R} = 1 - F_{12} = 0.542 \text{ and}$$

$$q_1 = \frac{\pi(0.25\text{m})^2 \times 5.67 \times 10^{-8} \text{ W/m}^2 \cdot \text{K}^4 (900^4 - 300^4) \text{ K}^4}{\frac{1 - 0.55}{0.55} + \frac{1}{0.458 + (3.69)^{-1}} + 0} = 3295 \text{ W} \quad <$$

### PROBLEM 13.71

**KNOWN:** Long hemi-cylindrical shaped furnace comprised of three zones.

**FIND:** (a) Heat rate per unit length of the furnace which must be supplied by the gas burners and (b) Temperature of the insulating brick.

**SCHEMATIC:**

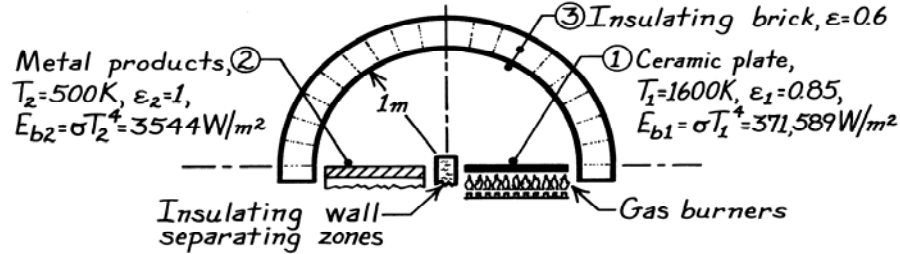

**ASSUMPTIONS:** (1) Surfaces are opaque, diffuse-gray or black, (2) Surfaces have uniform temperatures and radiositities, (3) Surface 3 is perfectly insulated, (4) Negligible convection, (5) Steady-state conditions.

**ANALYSIS:** (a) From an energy balance on the ceramic plate, the power required by the burner is  $q'_{\text{burners}} = q'_1$ , the net radiation leaving  $A_1$ ; hence

$$q'_1 = A_1 F_{12} (J_1 - J_2) + A_1 F_{13} (J_1 - J_3) = 0 + A_1 F_{13} (J_1 - J_3) \quad (1)$$

since  $F_{12} = 0$ . Note that  $J_2 = E_{b2} = \sigma T_2^4$  and that  $J_1$  and  $J_3$  are unknown. Hence, we need to write two radiation balances.

$$A_1: \quad \frac{E_{b1} - J_1}{(1 - \epsilon_1) / \epsilon_1 A_1} = q'_1 = 0 + A_1 F_{13} (J_1 - J_3) \quad (2)$$

$$A_3: \quad 0 = A_3 F_{31} (J_3 - J_1) + A_3 F_{32} (J_3 - E_{b2})$$

$$J_3 = \frac{J_1 + E_{b2}}{2} \quad (3)$$

since  $F_{31} = F_{23}$ . Substituting Eq. (3) into (2), find

$$(371,589 - J_1) / (1 - 0.85) / 0.85 = 1 [J_1 - (J_1 + 3,544) / 2]$$

$$J_1 = 341,748 \text{ W/m}^2 \quad J_3 = 172,646 \text{ W/m}^2$$

using  $E_{b1} = \sigma T_1^4 = 371,589 \text{ W/m}^2$  and  $E_{b2} = \sigma T_2^4 = 3544 \text{ W/m}^2$ . Substituting into Eq. (1), find

$$q'_1 = 1 \text{ m} \times 1 (341,748 - 172,646) \text{ W/m}^2 = 169 \text{ kW/m}. \quad <$$

(b) The temperature of the insulating brick, acting as a reradiating surface, is

$$J_3 = E_{b3} = \sigma T_3^4$$

$$T_3 = (J_3 / \sigma)^{1/4} = (172,646 \text{ W/m}^2 / 5.67 \times 10^{-8} \text{ W/m}^2 \cdot \text{K}^4)^{1/4} = 1320 \text{ K}. \quad <$$

## PROBLEM 13.72

**KNOWN:** Steam producing still heated by radiation.

**FIND:** (a) Factor by which the vapor production could be increased if the cylindrical side of the heater were insulated rather than open to the surroundings, and (b) Compute and plot the net heat rate of radiation transfer to the still, as a function of the separation distance  $L$  for the range  $15 \leq L \leq 100$  mm for heater temperatures of 600, 800, 1000°C considering the cylindrical sides to be insulated.

**SCHEMATIC:**

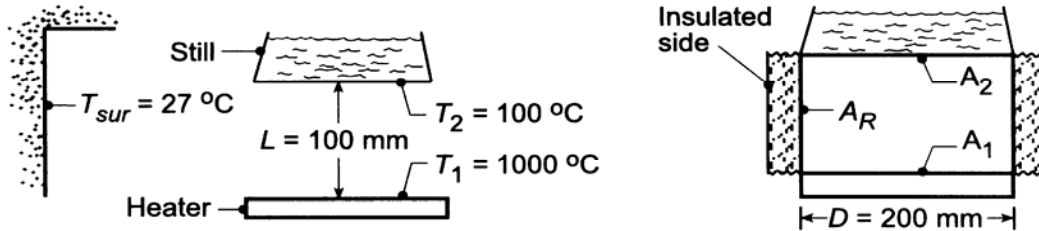

**ASSUMPTIONS:** (1) Still and heater surfaces are black, (2) Surroundings are isothermal and large compared to still heater surfaces, (3) Insulation is diffuse-gray, (4) Negligible convection.

**ANALYSIS:** (a) The vapor production will be proportional to the net radiation exchange to the still. For the case when the sides are open (o) to the surroundings, the net radiation exchange leaving  $A_2$  is from Eq. 13.14.

$$q_{2,o} = q_{21} + q_{2s} = A_2 F_{21} \sigma (T_2^4 - T_1^4) + A_2 F_{2s} \sigma (T_2^4 - T_{sur}^4)$$

where  $F_{2s} = 1 - F_{21}$  and  $F_{21}$  follows from Fig. 13.5 with  $L/r_1 = 100/100 = 1$ ,  $r_2/L = 100/100 = 1$ .

$$F_{21} = 0.38$$

With  $A_2 = \pi D^2 / 4$ , find

$$q_{2,o} = \frac{\pi (0.200 \text{ m})^2}{4} \times 5.67 \times 10^{-8} \text{ W/m}^2 \cdot \text{K}^4 \left\{ 0.38 (373^4 - 1273^4) + (1 - 0.38) (373^4 - 300^4) \right\}$$

$$q_{2,o} = -1752 \text{ W.} \quad \text{without insulation} \quad \leftarrow$$

With the cylindrical side insulated (i), a three-surface, re-radiating enclosure is formed. Eq. 13.30 can be used to evaluate  $q_{2,i}$  and with  $\varepsilon_2 = \varepsilon_1 = 1$ , the relation is

$$q_{2,i} = \frac{\sigma (T_2^4 - T_1^4)^4}{\frac{1}{A_1 F_{12} + [(1/A_1 F_{1R}) + (1/A_2 F_{2R})]^{-1}}} = A_1 \left\{ F_{12} + [1/F_{1R} + 1/F_{2R}]^{-1} \right\} \sigma (T_2^4 - T_1^4)$$

Recall  $F_{12} = 0.38$  and  $F_{1R} = 1 - F_{12} = 1 - 0.38 = 0.62$ , giving

$$q_{2,i} = \frac{\pi (0.200 \text{ m})^2}{4} \left\{ 0.38 + [1/0.62 + 1/0.62]^{-1} \right\} 5.67 \times 10^{-8} \text{ W/m}^2 \cdot \text{K} (373^4 - 1273^4) \text{ K}^4$$

$$q_{2,i} = -3204 \text{ W.} \quad \text{with insulation} \quad \leftarrow$$

Continued ...

### PROBLEM 13.72 (Cont.)

Hence, the vapor production rate is increased by a factor

$$\frac{q_2)_{\text{insul}}}{q_2)_{\text{open}}} = \frac{3204 \text{ W}}{1752 \text{ W}} = 1.83$$

That is, the vapor production is increased by 83%. <

(b) The *IHT Radiation Tool – Radiation Exchange Analysis* for the *Three-Surface Enclosure* with a *reradiating surface* can be used directly to compute the net heat rate to the still,  $q_1 = q_2$ , as a function of the separation distance  $L$  for selected heater temperatures  $T_1$ . The results are plotted below.

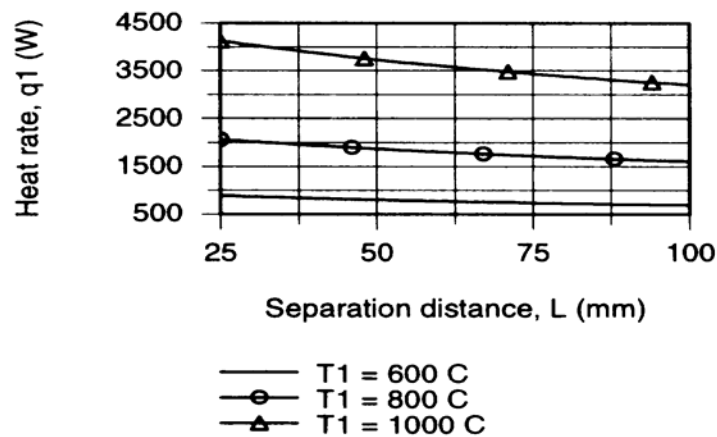

Note that the heat rate for all values of  $T_1$  decreases as expected with increasing separation distances, but not markedly. For any separation distance, increasing the heater temperature greatly influences the heat rate. For example, at  $L = 50$  mm, increasing  $T_1$  from 600 to 800 K, causes a nearly 6 fold increase in the heat rate. But increasing  $T_1$  from 800 to 1000 K causes only a 2 fold increase in the heat rate.

**COMMENTS:** When assigning the emissivity variables ( $\epsilon_1, \epsilon_2, \epsilon_3$ ) in the *IHT* model mentioned above, set  $\epsilon = 0.999$ , rather than 1.0, to avoid a “division by zero” error message. You could also call up the *Radiation Tool, View Factor Coaxial Parallel Disk* to calculate  $F_{12}$ .

### PROBLEM 13.73

**KNOWN:** Furnace with cylindrical heater and re-radiating, insulated walls.

**FIND:** (a) Power required to maintain steady-state conditions, (b) Temperature of wall area.

**SCHEMATIC:**

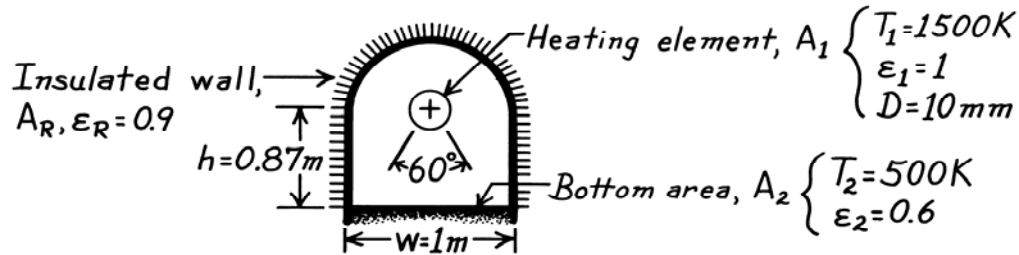

**ASSUMPTIONS:** (1) Surfaces are diffuse-gray, (2) Furnace is of length  $\ell$  where  $\ell \gg w$ , (3) Convection is negligible, (4)  $A_1 \ll A_2$ .

**ANALYSIS:** (a) Consider the furnace as a three surface enclosure with the walls,  $A_R$ , represented as a re-radiating surface. The power that must be supplied to the heater is determined by Eq. 13.30.

$$q_1 = \frac{\sigma(T_1^4 - T_2^4)}{(1 - \epsilon_1) / \epsilon_1 A_1 + \left[ A_1 F_{12} + \left[ (1 / A_1 F_{1R}) + (1 / A_2 F_{2R}) \right]^{-1} \right]^{-1} + (1 - \epsilon_2) / \epsilon_2 A_2}$$

Note that  $A_1 = \pi d \ell$  and  $A_2 = w \ell$ . By inspection and the summation rule, find  $F_{12} = 60^\circ / 360^\circ = 0.167$ ,  $F_{1R} = 1 - F_{12} = 1 - 0.167 = 0.833$ , and  $F_{2R} \approx 1$ . With  $q'_1 = q_1 / \ell$ ,

$$q'_1 = \frac{5.67 \times 10^{-8} \text{ W/m}^2 \cdot \text{K}^4 (1500^4 - 500^4) \text{ K}^4}{0 + \left[ \pi (10 \times 10^{-3}) \text{ m} \times 0.167 + \left[ (1 / \pi (10 \times 10^{-3}) \text{ m}) \times 0.833 + (1 / 1 \text{ m} \times 1) \right]^{-1} \right]^{-1} + (1 - 0.6) / 0.6 \times 1 \text{ m}}$$

$$q'_1 = 8518 \text{ W/m.} \quad <$$

(b) To determine the wall temperature, apply the radiation balance, Eq. 13.31,

$$\frac{J_1 - J_R}{(1 / A_1 F_{1R})} = \frac{J_R - J_2}{(1 / A_2 F_{2R})} \quad \text{or} \quad \frac{J_1 - J_R}{(1 / \pi 10 \times 10^{-3} \text{ m} \times 0.833)} = \frac{J_R - J_2}{(1 / 1 \text{ m} \times 1)}$$

$$J_R = \sigma T_R^4 = (J_1 + 38.21 J_2) / 39.21. \quad (1)$$

Since  $A_1$  is a blackbody,  $J_1 = E_{b1} = \sigma T_1^4$ . To determine  $J_2$ , use Eq. 13.19. Noting that  $q'_1 = -q'_2$ , find

$$q_2 = (E_{b2} - J_2) / (1 - \epsilon_2) / \epsilon_2 A_2 \quad \text{or} \quad J_2 = E_{b2} - q_2 (1 - \epsilon_2) / \epsilon_2 A_2$$

$$J_2 = 5.67 \times 10^{-8} \text{ W/m}^2 \cdot \text{K}^4 (500 \text{ K})^4 - \frac{(-8518 \text{ W/m})(1 - 0.6)}{0.6(1 \text{ m})} = 9222 \text{ W/m}^2.$$

Substituting this value for  $J_2$  into Eq. (1), the wall temperature can be calculated.

$$J_R = \left( 5.67 \times 10^{-8} \text{ W/m}^2 \cdot \text{K}^4 (1500 \text{ K})^4 + 38.21 \times 9222 \text{ W/m}^2 \right) / 39.21 = 16,308 \text{ W/m}^2$$

$$T_R = (J_R / \sigma)^{1/4} = \left( 16,308 \text{ W/m}^2 / 5.67 \times 10^{-8} \text{ W/m}^2 \cdot \text{K}^4 \right)^{1/4} = 732 \text{ K.} \quad <$$

**COMMENTS:** Considering the entire wall as a single re-radiating surface may be a poor assumption since  $J_R$  is not likely to be uniform over this large an area. It would be appropriate to consider several isothermal zones for improved accuracy.

### PROBLEM 13.74

**KNOWN:** Dimensions, temperature and emissivity of radiant heating tubes, temperature and emissivity of heated material, location of reradiating surface.

**FIND:** Net radiative heat flux to the heated material.

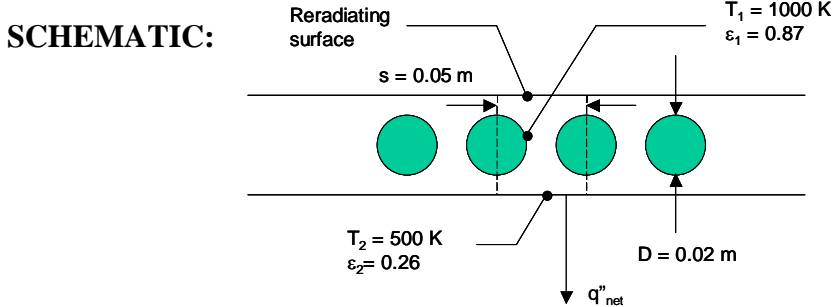

**ASSUMPTIONS:** Diffuse, gray behavior.

**ANALYSIS:** Treating the tubes as a single surface, the heat transfer rate from Surface 1 to Surface 2 is given by

$$q_1 = -q_2 = \frac{E_{b1} - E_{b2}}{\frac{1 - \epsilon_1}{\epsilon_1 A_1} + \frac{1}{A_1 F_{12} + \left[ \left( \frac{1}{A_1 F_{1R}} \right) + \left( \frac{1}{A_2 F_{2R}} \right) \right]^{-1}} + \frac{1 - \epsilon_2}{\epsilon_2 A_2}}$$

Utilizing the reciprocity relationship, incorporating the Stefan-Boltzmann law, and dividing by area  $A_2$ ,

$$q_1'' = -q_2'' = \frac{\sigma(T_1^4 - T_2^4)}{\frac{(1 - \epsilon_1)A_2}{\epsilon_1 A_1} + \frac{A_2}{A_2 F_{21} + \left[ \left( \frac{1}{A_R F_{R1}} \right) + \left( \frac{1}{A_2 F_{2R}} \right) \right]^{-1}} + \frac{1 - \epsilon_2}{\epsilon_2 A_2}} \quad (1)$$

From Table 13.1 for the infinite plane and row of cylinders,

$$F_{12} = 1 - \left[ 1 - \left( \frac{D}{s} \right)^2 \right]^{1/2} + \left( \frac{D}{s} \right) \tan^{-1} \left[ \left( \frac{s^2 - D^2}{D^2} \right)^{1/2} \right]$$

$$F_{21} = 1 - \left[ 1 - \left( \frac{0.02}{0.05} \right)^2 \right]^{1/2} + \left( \frac{0.02}{0.05} \right) \tan^{-1} \left[ \left( \frac{0.05^2 - 0.02^2}{0.02^2} \right)^{1/2} \right] = 0.5472 = F_{R1}$$

Therefore,  $F_{2R} = 1 - 0.5472 = 0.4528$ .

Continued...



### PROBLEM 13.74 (Cont.)

For a unit cell as shown in the schematic,  $A_2 = s$ ,  $A_1 = \pi D$ , and  $A_R = s$ . Therefore Eq. (1) is written as,

$$q_1'' = -q_2'' = \frac{\sigma(T_1^4 - T_2^4)}{\frac{(1 - \epsilon_1)s}{\epsilon_1 \pi D} + \frac{s}{sF_{21} + [(1/sF_{R1}) + (1/sF_{2R})]^{-1}} + \frac{(1 - \epsilon_2)}{\epsilon_2}}$$

or

$$q_1'' = -q_2'' = \frac{5.67 \times 10^{-8} \frac{\text{W}}{\text{m}^2 \cdot \text{K}^4} [(1000\text{K})^4 - (500\text{K})^4]}{\frac{(1 - 0.87) \times 0.05}{0.87 \times \pi \times 0.02} + \frac{0.05}{0.05 \times 0.5472 + [(1/0.05 \times 0.5472) + (1/0.05 \times 0.4528)]^{-1}} + \frac{(1 - 0.26)}{0.26}}$$

$$q_1'' = -q_2'' = 12,590 \text{ W/m}^2$$

<

**COMMENT:** The heat flux is independent of the separation distance between the heater and the material. Does this make sense to you?

### PROBLEM 13.75

**KNOWN:** Very long, triangular duct with walls that are diffuse-gray.

**FIND:** (a) Net radiation transfer from surface  $A_1$  per unit length of duct, (b) The temperature of the insulated surface, (c) Influence of  $\epsilon_3$  on the results; comment on exactness of results.

**SCHEMATIC:**

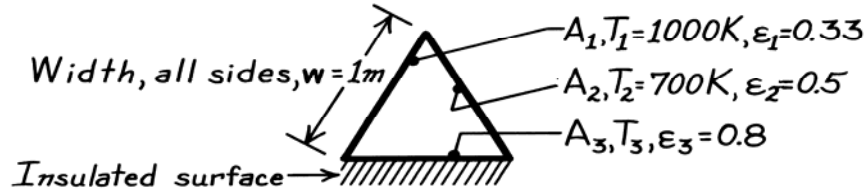

**ASSUMPTIONS:** (1) Surfaces are diffuse-gray, (2) Duct is very long; end effects negligible.

**ANALYSIS:** (a) The duct approximates a three-surface enclosure for which the third surface ( $A_3$ ) is re-radiating. Using Eq. 13.30 with  $A_3 = A_R$ , the net exchange is

$$q_1 = -q_2 = \frac{E_{b1} - E_{b2}}{\frac{(1-\epsilon_1)}{\epsilon_1 A_1} + \frac{1}{A_1 F_{12} + (1/A_1 F_{1R} + 1/A_2 F_{2R})^{-1}} + \frac{(1-\epsilon_2)}{\epsilon_2 A_2}} \quad (1)$$

From symmetry,  $F_{12} = F_{1R} = F_{2R} = 0.5$ . With  $A_1 = A_2 = w \cdot \ell$ , where  $\ell$  is the length normal to the page and  $w = 1$  m,

$$q'_1 = q_1 / \ell = (q_1 / A_1) w$$

$$q'_1 = \frac{(56,700 - 13,614) \text{ W/m}^2 \times 1 \text{ m}}{\frac{(1-0.33)}{0.33} + \frac{1}{0.5 + (1/0.5 + 1/0.5)^{-1}} + \frac{(1-0.5)}{0.5}} = 9874 \text{ W/m.} \quad <$$

(b) From a radiation balance on  $A_R$ ,

$$q_R = q_3 = 0 = \frac{E_{b3} - J_1}{(A_3 F_{31})^{-1}} + \frac{E_{b3} - J_2}{(A_3 F_{32})^{-1}} \quad \text{or} \quad E_{b3} = \frac{J_1 + J_2}{2} \quad (2)$$

To evaluate  $J_1$  and  $J_2$ , use Eq. 13.19,

$$J_i = E_{b,i} - \frac{q_i (1-\epsilon_i)}{A_i \epsilon_i} \begin{cases} J_1 = 56,700 - (9874) \frac{1-0.33}{0.33} = 36,653 \text{ W/m}^2 \\ J_2 = 13,614 - (-9874) \frac{1-0.5}{0.5} = 23,488 \text{ W/m}^2 \end{cases}$$

From Eq. (2), now find

$$T_3 = (E_{b3} / \sigma)^{1/4} = ([J_1 + J_2] / 2\sigma)^{1/4} = \left( \frac{(36,653 + 23,488) \text{ W/m}^2}{2(5.67 \times 10^{-8} \text{ W/m}^2 \cdot \text{K}^4)} \right)^{1/4} = 853 \text{ K.} \quad <$$

(c) Since  $A_3$  is adiabatic or re-radiating,  $J_3 = E_{b3}$ . Therefore, the value of  $\epsilon_3$  is of no influence on the radiation exchange or on  $T_3$ . In using Eq. (1), we require uniform radiosity over the surfaces. This requirement is not met near the corners. For best results we should subdivide the areas such that they represent regions of uniform radiosity. Of course, the analysis then becomes much more complicated.

### PROBLEM 13.76

**KNOWN:** Dimensions for aligned rectangular heater and coated plate. Temperatures of heater, plate and large surroundings.

**FIND:** (a) Electric power required to operate heater, (b) Heater power required if reradiating sidewalls are added, (c) Effect of coating emissivity and electric power.

**SCHEMATIC:**

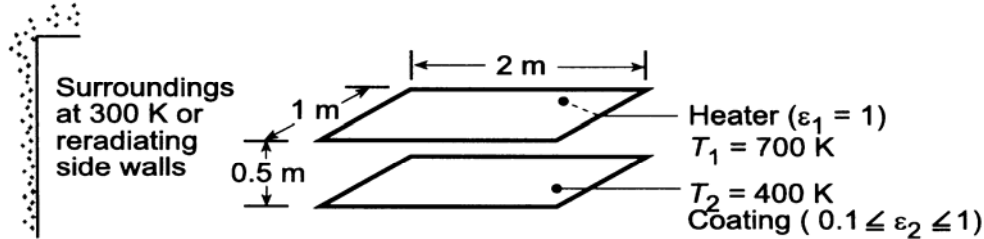

**ASSUMPTIONS:** (1) Steady-state, (2) Blackbody behavior for surfaces and surroundings (Parts (a) and (b)).

**ANALYSIS:** (a) For  $\epsilon_1 = \epsilon_2 = 1$ , the net radiation leaving  $A_1$  is

$$q_{\text{elec}} = q_1 = A_1 F_{12} \sigma (T_1^4 - T_2^4) + A_1 F_{1\text{sur}} \sigma (T_1^4 - T_{\text{sur}}^4).$$

From Fig. 13.4, with  $Y/L = 1/0.5 = 2$  and  $X/L = 2/0.5 = 4$ , the view factors are  $F_{12} \approx 0.5$  and  $F_{\text{sur}} \approx 1 - 0.5 = 0.5$ . Hence,

$$q_{\text{elec}} = (2\text{m}^2) 0.5 \times 5.67 \times 10^{-8} \text{W/m}^2 \cdot \text{K}^4 \left[ (700 \text{K})^4 - (400 \text{K})^4 \right] \\ + (2\text{m}^2) 0.5 \times 5.67 \times 10^{-8} \text{W/m}^2 \cdot \text{K}^4 \left[ (700 \text{K})^4 - (300 \text{K})^4 \right] = (12,162 + 13,154) \text{W} = 25,316 \text{W}. <$$

(b) With the reradiating walls, the net radiation leaving  $A_1$  is  $q_{\text{elec}} = q_1 = q_{12}$ . From Eq. 13.30 with  $\epsilon_1 = \epsilon_2 = 1$  and  $A_1 = A_2$ ,

$$q_{\text{elec}} = A_1 \sigma (T_1^4 - T_2^4) \left\{ F_{12} + [(1/F_{1R}) + (1/F_{2R})]^{-1} \right\} \\ q_{\text{elec}} = (2\text{m}^2) 5.67 \times 10^{-8} \text{W/m}^2 \cdot \text{K}^4 \left[ (700 \text{K})^4 - (400 \text{K})^4 \right] \times \left\{ 0.5 + [(1/0.5) + (1/0.5)]^{-1} \right\}$$

$$q_{\text{elec}} = 18,243 \text{W}. <$$

(c) Separately using the *IHT Radiation Tool Pad* for a three-surface enclosure, with one surface reradiating, and to perform a radiation exchange analysis for a three-surface enclosure, with one surface corresponding to large surroundings, the following results were obtained.

Continued ...

### PROBLEM 13.76 (Cont.)

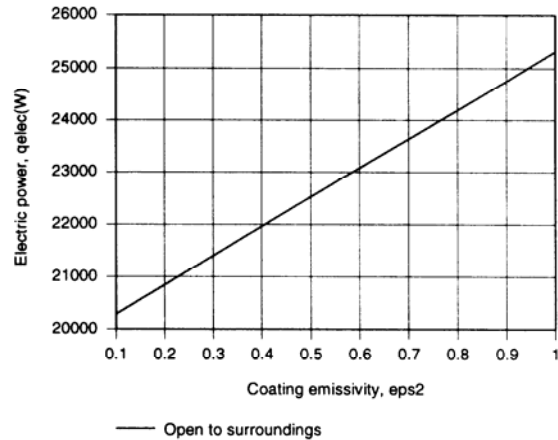
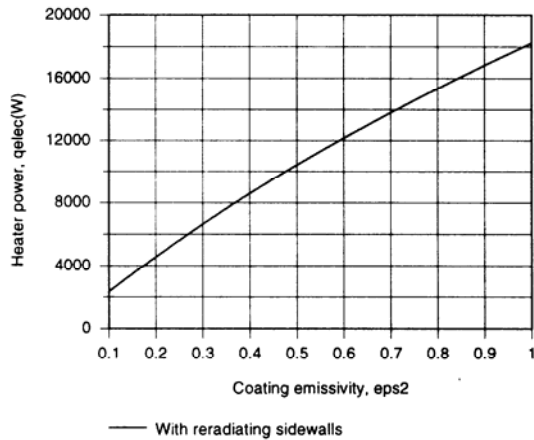

In both cases, the required heater power decreases with decreasing  $\epsilon_2$ , and the trend is attributed to a reduction in  $\alpha_2 = \epsilon_2$  and hence to a reduction in the rate at which radiant energy must be absorbed by the surface to maintain the prescribed temperature.

**COMMENTS:** With the reradiating walls in part (b), it follows from Eq. 13.31 that

$$J_R = E_{bR} = (J_1 + J_2) / 2 = (E_{b1} + E_{b2}) / 2.$$

Hence,  $T_R = 604$  K. The reduction in  $q_{elec}$  resulting from use of the walls is due to the enhancement of radiation to the heater, which, in turn, is due to the presence of the high temperature walls.

### PROBLEM 13.77

**KNOWN:** Configuration and operating conditions of a furnace. Initial temperature and emissivity of steel plate to be treated.

**FIND:** (a) Heater temperature, (b) Sidewall temperature.

**SCHEMATIC:**

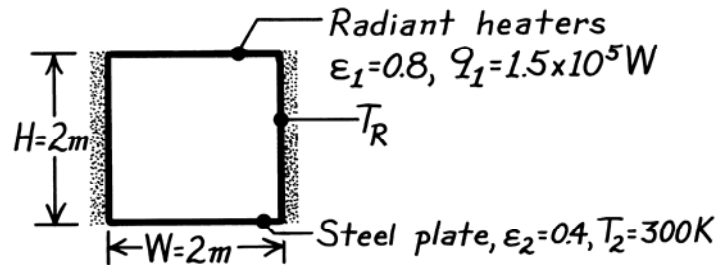

**ASSUMPTIONS:** (1) Steady-state conditions, (2) Opaque, diffuse-gray surface behavior, (3) Negligible convection, (4) Sidewalls are re-radiating.

**ANALYSIS:** (a) From Eq. 13.30

$$q_1 = \frac{E_{b1} - E_{b2}}{\frac{1 - \epsilon_1}{\epsilon_1 A_1} + \frac{1}{A_1 F_{12} + \left[ (A_1 F_{1R})^{-1} + (A_2 F_{2R})^{-1} \right]^{-1}} + \frac{1 - \epsilon_2}{\epsilon_2 A_2}} = 1.5 \times 10^5 \text{ W}$$

Note that  $A_1 = A_2 = 4 \text{ m}^2$  and  $E_{b2} = \sigma T_2^4 = 5.67 \times 10^{-8} \text{ W/m}^2 \cdot \text{K}^4 (300 \text{ K})^4 = 459 \text{ W/m}^2$ . From Fig. 13.4, with  $X/L = Y/L = 1$ ,  $F_{12} = 0.2$ ; hence  $F_{1R} = 1 - F_{12} = 0.8$ , and  $F_{2R} = F_{1R} = 0.8$ . With  $(1 - \epsilon_1)/\epsilon_1 = 0.25$  and  $(1 - \epsilon_2)/\epsilon_2 = 1.5$ , find

$$\frac{1.5 \times 10^5 \text{ W}}{4 \text{ m}^2} = \frac{E_{b1} - 459 \text{ W/m}^2}{0.25 + \frac{1}{0.2 + [1.25 + 1.25]^{-1}} + 1.5} = \frac{E_{b1} - 459 \text{ W/m}^2}{3.417}$$

$$E_{b1} = 1.28 \times 10^5 \text{ W/m}^2 + 459 \text{ W/m}^2 = 1.29 \times 10^5 \text{ W/m}^2 = \sigma T_1^4$$

$$T_1 = \left( 1.29 \times 10^5 \text{ W/m}^2 / 5.67 \times 10^{-8} \text{ W/m}^2 \cdot \text{K}^4 \right)^{1/4} = 1228 \text{ K}.$$

(b) From Eq. 13.31, it follows that, with  $A_1 F_{1R} = A_2 F_{2R}$ ,

$$J_R = \sigma T_R^4 = (J_1 + J_2) / 2$$

$$\text{From Eq. 13.19, } J_1 = E_{b1} - \frac{(1 - \epsilon_1)}{\epsilon_1 A_1} q_1 = 1.29 \times 10^5 \text{ W/m}^2 - \frac{0.2 \times 1.5 \times 10^5 \text{ W}}{0.8 \times 4 \text{ m}^2}$$

$$J_1 = 1.196 \times 10^5 \text{ W/m}^2.$$

With  $q_2 = q_1 = -1.5 \times 10^5 \text{ W}$ ,

$$J_2 = E_{b2} - \frac{(1 - \epsilon_2)}{\epsilon_2 A_2} q_2 = 459 \text{ W/m}^2 + \frac{0.6}{0.4 \times 4 \text{ m}^2} 1.5 \times 10^5 \text{ W} = 5.67 \times 10^4 \text{ W/m}^2$$

$$T_R = \left( \frac{1.196 \times 10^5 \text{ W/m}^2 + 5.67 \times 10^4 \text{ W/m}^2}{2 \times 5.67 \times 10^{-8} \text{ W/m}^2 \cdot \text{K}^4} \right)^{1/4} = 1117 \text{ K}.$$

**COMMENTS:** (1) The above results are approximate, since the process is actually transient. (2)  $T_1$  and  $T_R$  will increase with time as  $T_2$  increases.

### PROBLEM 13.78

**KNOWN:** Dimensions, surface radiative properties, and operating conditions of an electrical furnace.

**FIND:** (a) Equivalent radiation circuit, (b) Furnace power requirement and temperature of a heated plate.

**SCHEMATIC:**

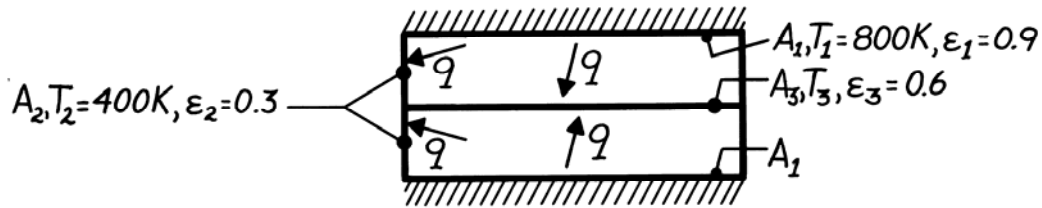

**ASSUMPTIONS:** (1) Steady-state conditions, (2) Opaque, diffuse-gray surfaces, (3) Negligible plate temperature gradients, (4) Back surfaces of heater are adiabatic, (5) Convection effects are negligible.

**ANALYSIS:** (a) Since there is symmetry about the plate, only one-half (top or bottom) of the system need be considered. Moreover, the plate must be adiabatic, thereby playing the role of a re-radiating surface.

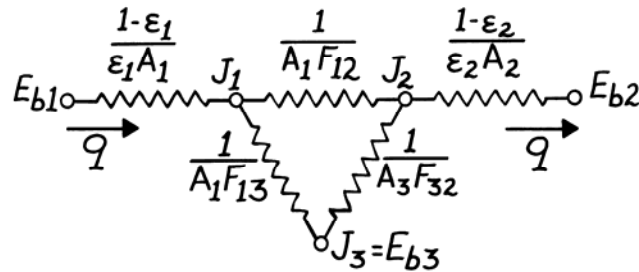

(b) Note that  $A_1 = A_3 = 4 \text{ m}^2$  and  $A_2 = (0.5 \text{ m} \times 2 \text{ m})4 = 4 \text{ m}^2$ . From Fig. 13.4, with  $X/L = Y/L = 4$ ,  $F_{13} = 0.62$ . Hence

$$F_{12} = 1 - F_{13} = 0.38, \quad \text{and} \quad F_{32} = F_{12} = 0.38.$$

It follows that

$$A_1 F_{12} = 4(0.38) = 1.52 \text{ m}^2$$

$$A_1 F_{13} = 4(0.62) = 2.48 \text{ m}^2, \quad (1 - \epsilon_1) / \epsilon_1 A_1 = 0.1 / 3.6 \text{ m}^2 = 0.0278 \text{ m}^{-2}$$

$$A_3 F_{32} = 4(0.38) = 1.52 \text{ m}^2, \quad (1 - \epsilon_2) / \epsilon_2 A_2 = 0.7 / 1.2 \text{ m}^2 = 0.583 \text{ m}^{-2}.$$

Also,

$$E_{b1} = \sigma T_1^4 = 5.67 \times 10^{-8} \text{ W/m}^2 \cdot \text{K}^4 (800 \text{ K})^4 = 23,224 \text{ W/m}^2,$$

$$E_{b2} = \sigma T_2^4 = 5.67 \times 10^{-8} \text{ W/m}^2 \cdot \text{K}^4 (400 \text{ K})^4 = 1452 \text{ W/m}^2.$$

The system forms a three-surface enclosure, with one surface re-radiating. Hence the net radiation transfer from a single heater is, from Eq. 13.30,

$$q_1 = \frac{E_{b1} - E_{b2}}{\frac{1 - \epsilon_1}{\epsilon_1 A_1} + \frac{1}{A_1 F_{12} + [1/A_1 F_{13} + 1/A_3 F_{32}]^{-1}} + \frac{1 - \epsilon_2}{\epsilon_2 A_2}}$$

Continued ...

**PROBLEM 13.78 (Cont.)**

$$q_1 = \frac{(23,224 - 1452) \text{ W/m}^2}{(0.0278 + 0.4061 + 0.583) \text{ m}^{-2}} = 21.4 \text{ kW.}$$

The furnace power requirement is therefore  $q_{\text{elec}} = 2q_1 = 43.8 \text{ kW}$ , with

<

$$q_1 = \frac{E_{b1} - J_1}{(1 - \varepsilon_1) / \varepsilon_1 A_1}.$$

where

$$J_1 = E_{b1} - q_1 \frac{1 - \varepsilon_1}{\varepsilon_1 A_1} = 23,224 \text{ W/m}^2 - 21,400 \text{ W} \times 0.0278 \text{ m}^{-2}$$

$$J_1 = 22,679 \text{ W/m}^2.$$

Also,

$$J_2 = E_{b2} - q_2 \frac{1 - \varepsilon_2}{\varepsilon_2 A_2} = 1,452 \text{ W/m}^2 - (-21,400 \text{ W}) \times 0.583 \text{ m}^{-2}$$

$$J_2 = 13,928 \text{ W/m}^2.$$

From Eq. 13.31,

$$\frac{J_1 - J_3}{1/A_1 F_{13}} = \frac{J_3 - J_2}{1/A_3 F_{32}}$$

$$\frac{J_1 - J_3}{J_3 - J_2} = \frac{A_3 F_{32}}{A_1 F_{13}} = \frac{1.52}{2.48} = 0.613$$

$$1.613 J_3 = J_1 + 0.613 J_2 = 22,629 + 8537 = 31,166 \text{ W/m}^2$$

$$J_3 = 19,321 \text{ W/m}^2$$

Since  $J_3 = E_{b3}$ ,

$$T_3 = (E_{b3} / \sigma)^{1/4} = (19,321 / 5.67 \times 10^{-8})^{1/4} = 764 \text{ K.}$$

<

**COMMENTS:** (1) To reduce  $q_{\text{elec}}$ , the sidewall temperature  $T_2$ , should be increased by insulating it from the surroundings. (2) The problem must be solved by simultaneously determining  $J_1$ ,  $J_2$  and  $J_3$  from the radiation balances of the form

$$\frac{E_{b1} - J_1}{(1 - \varepsilon_1) / \varepsilon_1 A_1} = A_1 F_{12} (J_1 - J_2) + A_1 F_{13} (J_1 - J_3)$$

$$\frac{E_{b2} - J_2}{(1 - \varepsilon_2) / \varepsilon_2 A_2} = A_2 F_{21} (J_2 - J_1) + A_2 F_{23} (J_2 - J_3)$$

$$0 = A_1 F_{13} (J_3 - J_1) + A_2 F_{23} (J_3 - J_2).$$

### PROBLEM 13.79

**KNOWN:** Geometry and surface temperatures and emissivities of a solar collector.

**FIND:** Net rate of radiation transfer to cover plate due to exchange with the absorber plates.

**SCHEMATIC:**

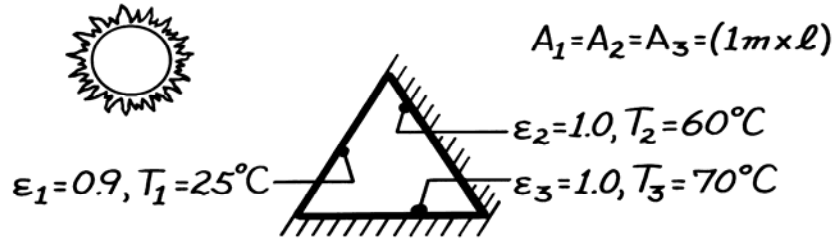

**ASSUMPTIONS:** (1) Isothermal surfaces with uniform radiosity, (2) Absorber plates behave as blackbodies, (3) Cover plate is diffuse-gray and opaque to thermal radiation exchange with absorber plates, (4) Duct end effects are negligible.

**ANALYSIS:** Applying Eq. 13.21 to the cover plate, it follows that

$$E_{b1} - J_1 = \frac{1 - \varepsilon_1}{\varepsilon_1 A_1} \sum_{j=1}^N \frac{J_1 - J_j}{(A_1 F_{1j})^{-1}} = \frac{1 - \varepsilon_1}{\varepsilon_1 A_1} [A_1 F_{12} (J_1 - J_2) + A_1 F_{13} (J_1 - J_3)].$$

From symmetry,  $F_{12} = F_{13} = 0.5$ . Also,  $J_2 = E_{b2}$  and  $J_3 = E_{b3}$ . Hence

$$E_{b1} - J_1 = 0.0556(2J_1 - E_{b2} - E_{b3})$$

or with  $E_b = \sigma T^4$ ,

$$1.111J_1 = E_{b1} + 0.0556(E_{b2} + E_{b3})$$

$$1.111J_1 = 5.67 \times 10^{-8} (298)^4 \text{ W/m}^2 + 0.0556 \left( 5.67 \times 10^{-8} \right) \left[ (333)^4 + (343)^4 \right] \text{ W/m}^2$$

$$J_1 = 476.64 \text{ W/m}^2$$

From Eq. 13.19 the net rate of radiation transfer *from* the cover plate is then

$$q_1 = \frac{E_{b1} - J_1}{(1 - \varepsilon_1) / \varepsilon_1 A_1} = \frac{5.67 \times 10^{-8} (298)^4 - 476.64}{(1 - 0.9) / 0.9(\ell)} = (-265.5\ell) \text{ W.}$$

The net rate of radiation transfer *to* the cover plate per unit length is then

$$q'_1 = (q_1 / \ell) = 266 \text{ W/m.} \quad <$$

**COMMENTS:** Solar radiation effects are not relevant to the foregoing problem. All such radiation transmitted by the cover plate is completely absorbed by the absorber plate.



### PROBLEM 13.80

**KNOWN:** Dimensions of cylinder and piston, mass of air contained in the cylinder, emissivity of surfaces, bottom surface temperature and surroundings temperature, density of piston material.

**FIND:** Distance between bottom of piston and bottom of cylinder and temperature of the piston for  $T_1 = 300, 450$  and  $600$  K.

**SCHEMATIC:**

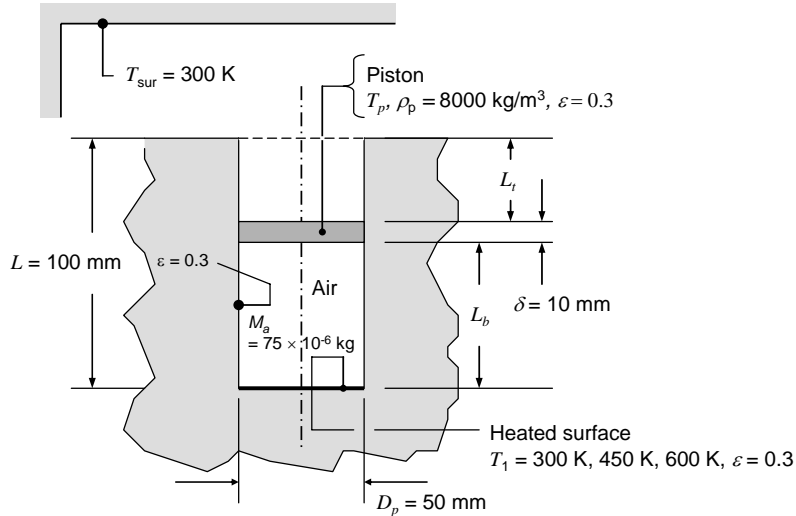

**ASSUMPTIONS:** (1) Diffuse-gray surfaces with uniform radiosity and irradiation, (2) Negligible convection heat transfer, (3) Ideal gas behavior, (4) Frictionless, isothermal piston, (5) Air temperature is average of bottom surface temperature and piston temperature, (6) Low thermal conductivity material is re-radiating.

**ANALYSIS:** The position and temperature of the piston are governed by energy and force balances that are applied to a control volume surrounding the piston.

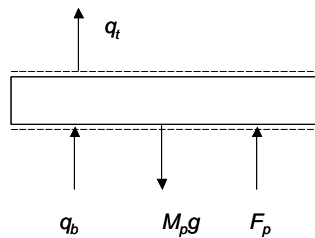

Treating the air as an ideal gas,

$$P_a V_a = M_a (\mathcal{R} / \mathcal{M}) \bar{T}_a \quad (1)$$

where  $\bar{T}_a = (T_p + T_1) / 2$ . The force balance yields

$$p_a = M_p g + p_{atm} = \rho_p (\pi D_p^2 / 4) \delta g + p_{atm} \quad (2)$$

At steady state,

$$q_t = q_b \quad (3)$$

Continued...

### PROBLEM 13.80 (Cont.)

where the heat rates are determined by evaluating the radiation heat transfer in two enclosures; one enclosure formed by three surfaces below the piston (bottom of cylinder, bottom of piston and reradiating side wall) and the second enclosure formed by three surfaces above the piston (top of piston, hypothetical surface at the top of the cylinder and reradiating side wall).

Using Eq. 13.30 for the bottom enclosure,

$$q_b = \frac{E_{b1} - E_{bp}}{\frac{1 - \varepsilon_1}{\varepsilon_1 A_1} + \frac{1}{A_1 F_{1-p} + \left[ \left( 1/A_1 F_{1-Rb} \right) + \left( 1/A_p F_{p-Rb} \right) \right]^{-1}} + \frac{1 - \varepsilon_p}{\varepsilon_p A_p}} \quad (4)$$

while for the top enclosure,

$$q_t = \frac{E_{bp} - E_{bsur}}{\frac{1 - \varepsilon_p}{\varepsilon_p A_p} + \frac{1}{A_p F_{p-sur} + \left[ \left( 1/A_p F_{p-Rt} \right) + \left( 1/A_{sur} F_{sur-p} \right) \right]^{-1}} + \frac{1 - \varepsilon_{sur}}{\varepsilon_{sur} A_{sur}}} \quad (5)$$

The three emissive powers are

$$E_{b1} = \sigma T_1^4; \quad E_{bp} = \sigma T_p^4; \quad E_{bsur} = \sigma T_{sur}^4 \quad (6a,b,c)$$

The surface areas are

$$A_1 = A_p = A_{sur} = \pi D_p^2 / 4 \quad (7a,b,c)$$

while the gas volume is

$$V = (\pi D_p^2 / 4) L_b \quad (8)$$

The universal gas constant is  $\mathcal{R} = 8315 \text{ J/kmol}\cdot\text{K}$  and the molecular weight of the air is  $\mathcal{M} = 28.97 \text{ kg/kmol}$ .

View factors for use in Eqs. 4 and 5 are evaluated using the expressions for coaxial parallel disks in Table 13.2. For the bottom enclosure,

$$\begin{aligned} R_{ib} = R_{jb} = D/(2L_b), \quad S_b = 1 + (1 + R_{jb}^2)/R_{ib}^2, \quad F_{1-p} = 0.5(S_b - [S_b^2 - 4]^{1/2}), \\ F_{1-Rb} = 1 - F_{1-p}, \quad F_{p-Rb} = F_{1-Rb}. \end{aligned} \quad (9a,b,c,d,e,f)$$

For the top enclosure,

$$\begin{aligned} R_{it} = R_{jt} = D/(2L_t), \quad S_t = 1 + (1 + R_{jt}^2)/R_{it}^2, \quad F_{p-sur} = 0.5(S_t - [S_t^2 - 4]^{1/2}), \\ F_{p-Rt} = 1 - F_{p-sur}, \quad F_{sur-p} = F_{p-sur} \end{aligned} \quad (10a,b,c,d,e,f)$$

The lengths are related by

Continued...

### PROBLEM 13.80 (Cont.)

$$L_b + L_t + \delta = L \quad (11)$$

Simultaneous solution of Eqs. 1 through 11 yields the following results, presented in tabular form.

Input Variable		Results		View Factors					
$T_1$ (K)	$L_b$ (mm)	$T_p$ (K)	$q_b$ (W)	$F_{l-Rb}$	$F_{l-p}$	$F_{p-Rb}$	$F_{p-Rt}$	$F_{p-sur}$	$F_{sur-p}$
300	0.033	300	0	-	-	-	-	-	-
450	0.045	389.2	0.32	0.804	0.196	0.804	0.799	0.201	0.201
600	0.059	488	1.26	0.865	0.135	0.865	0.691	0.309	0.309

**COMMENTS:** As the temperature of the bottom surface increases, the gas temperature increases leading to expansion of the air and increased  $L_b$ . To solve Eqs. 1 through 11 requires a potentially tedious trial-and-error solution. The tedium is reduced significantly by using IHT. One approach is to guess values of  $L_b$  (or  $L_t$ ) and solve the equations until  $q_b = q_t$ . In doing so, one discovers that multiple solutions exist, but the second solution is unrealistic since piston temperatures are outside the range  $T_1 > T_p > T_{sur}$ .

### PROBLEM 13.81

**KNOWN:** Cylindrical peep-hole of diameter  $D$  through a furnace wall of thickness  $L$ . Temperatures prescribed for the furnace interior and surroundings outside the furnace.

**FIND:** Heat loss by radiation through the peep-hole.

**SCHEMATIC:**

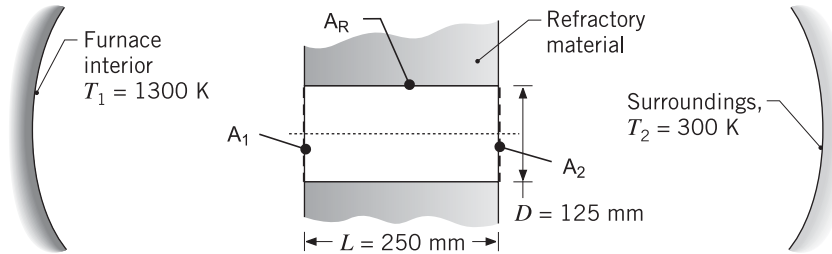

**ASSUMPTIONS:** (1) Steady-state conditions, (2) Furnace interior and exterior surroundings are large, isothermal surroundings for the peep-hole openings, (3) Furnace refractory wall is adiabatic and diffuse-gray with uniform radiosity.

**ANALYSIS:** The open-ends of the cylindrical peep-hole ( $A_1$  and  $A_2$ ) and the cylindrical lateral surface of the refractory material ( $A_R$ ) form a diffuse-gray, three-surface enclosure. The hypothetical areas  $A_1$  and  $A_2$  behave as black surfaces at the respective temperatures of the large surroundings to which they are exposed. Since  $A_R$  is adiabatic, it behaves as a re-radiating surface, and its emissivity has no effect on the analysis. From Eq. 13.30, the net radiation leaving  $A_1$  passes through the enclosure into the outer surroundings.

$$q_1 = -q_2 = \frac{E_{b1} - E_{b2}}{\frac{1 - \varepsilon_1}{\varepsilon_1 A_1} + \frac{1}{A_1 F_{12} + [(1/A_1 F_{1R}) + (1/A_2 F_{2R})]^{-1}} + \frac{1 - \varepsilon_2}{\varepsilon_2 A_2}}$$

Since  $\varepsilon_1 = \varepsilon_2 = 1$ , and with  $E_b = \sigma T^4$  where  $\sigma = 5.67 \times 10^{-8} \text{ W/m}^2 \cdot \text{K}^4$ ,

$$q_1 = \left\{ A_1 F_{12} + [(1/A_1 F_{1R}) + (1/A_2 F_{2R})]^{-1} \right\} \sigma (T_1^4 - T_2^4)$$

where  $A_1 = A_2 = \pi D^2/4$ . The view factor  $F_{12}$  can be determined from Table 13.2 (Fig. 13.5) for the coaxial parallel disks ( $R_1 = R_2 = 125/(2 \times 250) = 0.25$  and  $S = 17.063$ ) as

$$F_{12} = 0.05573$$

From the summation rule on  $A_1$ , with  $F_{11} = 0$ ,

$$F_{11} + F_{12} + F_{1R} = 1$$

$$F_{1R} = 1 - F_{12} = 1 - 0.05573 = 0.9443$$

and from symmetry of the enclosure,

$$F_{2R} = F_{1R} = 0.9443$$

Substituting numerical values into the rate equation, find the heat loss by radiation through the peep-hole to the exterior surroundings as

$$q_{\text{loss}} = q_1 = 1046 \text{ W}$$

<

**COMMENTS:** If you held your hand 50 mm from the exterior opening of the peep-hole, how would that feel? It is standard, safe practice to use optical protection when viewing the interiors of high temperature furnaces as used in petrochemical, metals processing and power generation operations.

### PROBLEM 13.82

**KNOWN:** Composite wall comprised of two large plates separated by sheets of refractory insulation of thermal conductivity  $k = 0.05 \text{ W/m}\cdot\text{K}$ ; gaps between the sheets of width  $w = 10 \text{ mm}$ , located at  $1\text{-m}$  spacing, allow radiation transfer between the plates.

**FIND:** (a) Heat loss by radiation through the gap per unit length of the composite wall (normal to the page), and (b) fraction of the total heat loss through the wall that is due to radiation transfer through the gap.

**SCHEMATIC:**

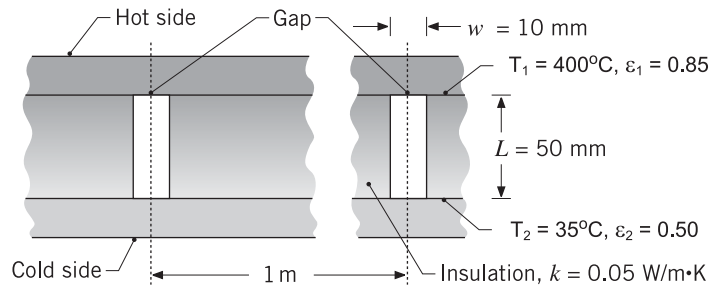

**ASSUMPTIONS:** (1) Steady-state conditions, (2) Surfaces are diffuse-gray with uniform radiosities, (3) Refractory insulation surface in the gap is adiabatic, and (4) Heat flow through the wall is one-dimensional between the plates in the direction of the gap centerline, (5) Negligible contact resistance, (6) Negligible free convection in gap.

**PROPERTIES:** Air ( $T = 490 \text{ K}$ ):  $k = 0.040 \text{ W/m}\cdot\text{K}$ .

**ANALYSIS:** (a) The gap of thickness  $w$  and infinite extent normal to the page can be represented by a diffuse-gray, three-surface enclosure formed by the plates  $A_1$  and  $A_2$  and the refractory walls,  $A_R$ . Since  $A_R$  is adiabatic, it behaves as a re-radiating surface, and its emissivity has no effect on the analysis. From Eq. 13.30, the net radiation leaving the plate  $A_1$  passes through the gap into plate  $A_2$ .

$$q_1 = -q_2 = \frac{E_{b1} - E_{b2}}{\frac{1 - \varepsilon_1}{\varepsilon_1 A_1} + \frac{1}{A_1 F_{12} + \left[ \left( \frac{1}{A_1 F_{1R}} \right) + \left( \frac{1}{A_2 F_{2R}} \right) \right]^{-1}} + \frac{1 - \varepsilon_2}{\varepsilon_2 A_2}}$$

where  $E_b = \sigma T^4$  with  $\sigma = 5.67 \times 10^{-8} \text{ W/m}^2 \cdot \text{K}^4$  and  $A_1 = A_2 = w \cdot \ell$ , but making  $\ell = 1 \text{ m}$  to obtain  $q'_1$  ( $\text{W/m}$ ).

The view factor  $F_{12}$  can be determined from Table 13.2 (Fig. 13.4) for aligned parallel rectangles where  $\bar{X} = X/L = \infty$  since  $X \rightarrow \infty$  and  $\bar{Y} = Y/L = W/L = 10/50 = 0.2$  giving

$$F_{12} = 0.09902$$

From the summation rule on  $A_1$ , with  $F_{11} = 0$ ,

$$F_{11} + F_{12} + F_{1R} = 1 \qquad F_{1R} = 1 - F_{12} = 1 - 0.09902 = 0.901$$

and from symmetry of the enclosure,

Continued ...

### PROBLEM 13.82 (Cont.)

$$F_{2R} = F_{1R} = 0.901.$$

Substituting numerical values into the rate equation, find the heat loss through the gap due to radiation as

$$q'_{\text{rad}} = q'_1 = 37 \text{ W/m} \quad <$$

(b) The conduction heat rate per unit length (normal to the page) for a 1 - m section is

$$q'_{\text{cond}} = q'_{\text{cond, ins}} + q'_{\text{cond, air}} = 0.05 \text{ W/m} \cdot \text{K} \times (1 \text{ m} - 0.1 \text{ m}) \frac{(400 - 35) \text{ K}}{0.050 \text{ mm}} \\ + 0.04 \text{ W/m} \cdot \text{K} \times 0.01 \text{ m} \frac{(400 - 35) \text{ K}}{0.050 \text{ mm}}$$

$$q'_{\text{cond}} = 361.4 \text{ W/m} + 2.92 \text{ W/m} = 364 \text{ W/m}$$

The fraction of the total heat transfer through the 1 - m section due to radiation is

$$\frac{q'_{\text{rad}}}{q'_{\text{tot}}} = \frac{q'_{\text{rad}}}{q'_{\text{cond}} + q'_{\text{rad}}} = \frac{37}{364 + 37} = 9.2\% \quad <$$

We conclude that if the installation process for the sheet insulation can be accomplished with a smaller gap, there is an opportunity to reduce the cost of operating the furnace.

### PROBLEM 13.83

**KNOWN:** Diameter, temperature and emissivity of a heated disk. Diameter and emissivity of a hemispherical radiation shield. View factor of shield with respect to a coaxial disk of prescribed diameter, emissivity and temperature.

**FIND:** (a) Equivalent circuit, (b) Net heat rate from the hot disk.

**SCHEMA:**

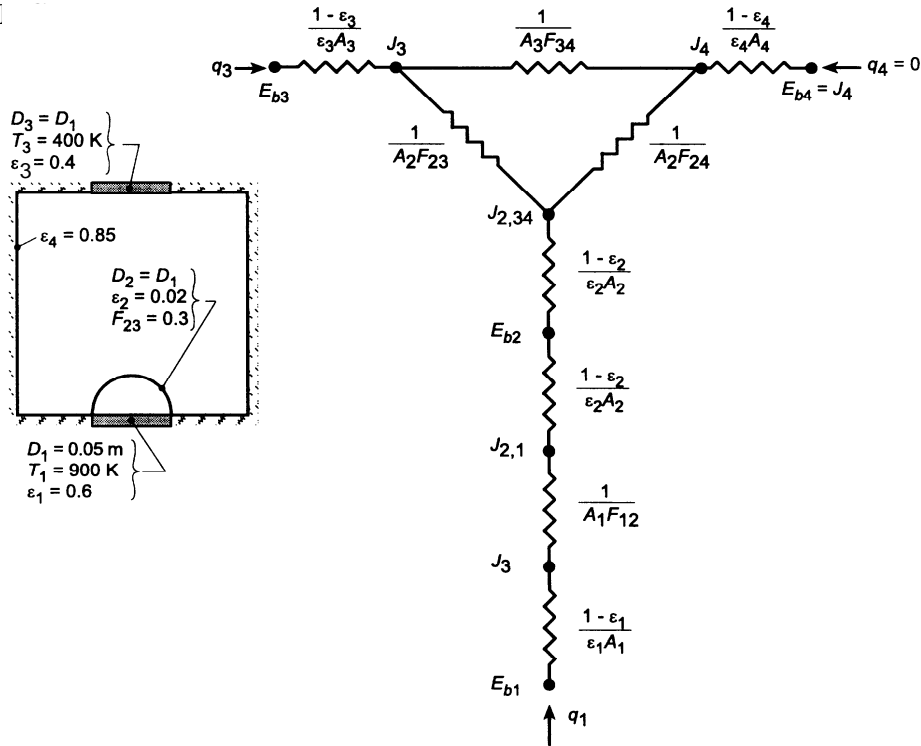

**ASSUMPTIONS:** (1) Surfaces may be approximated as diffuse/gray, (2) Surface 4 is reradiating, (3) Negligible convection.

**ANALYSIS:** (a) The equivalent circuit is shown in the schematic. Since surface 4 is treated as reradiating, the net transfer of radiation from surface 1 is equal to the net transfer of radiation to surface 3 ( $q_1 = -q_3$ ).

(b) From the thermal circuit, the desired heat rate may be expressed as

$$q_1 = \frac{E_{b1} - E_{b3}}{\frac{1-\epsilon_1}{\epsilon_1 A_1} + \frac{1}{A_1 F_{12}} + \frac{2(1-\epsilon_2)}{\epsilon_2 A_2} + \left[ A_2 F_{23} + \frac{1}{\frac{1}{A_2 F_{24}} + \frac{1}{A_3 F_{34}}} \right]^{-1} + \frac{1-\epsilon_3}{\epsilon_3 A_3}}$$

where  $A_1 = A_3 = \pi D_1^2 / 4 = \pi(0.05 \text{ m})^2 / 4 = 1.963 \times 10^{-3} \text{ m}^2$ ,  $A_2 = \pi D_1^2 / 2 = 2A_1 = 3.925 \times 10^{-3} \text{ m}^2$ ,  $F_{12} = 1$ , and  $F_{24} = 1 - F_{23} = 0.7$ . With  $F_{34} = 1 - F_{32} = 1 - F_{23}(A_2/A_3) = 1 - 0.3(2) = 0.4$ , it follows that

Continued ...

**PROBLEM 13.83 (Cont.)**

$$q_1 = \frac{A_1 \sigma (T_1^4 - T_3^4)}{\frac{1-\varepsilon_1}{\varepsilon_1} + \frac{1}{F_{12}} + \frac{2(1-\varepsilon_2)}{\varepsilon_2} \frac{A_1}{A_2} + \left[ \frac{A_2}{A_1} F_{23} + \frac{1}{\frac{A_1}{A_2 F_{24}} + \frac{A_1}{A_3 F_{34}}} \right]^{-1} + \frac{1-\varepsilon_3}{\varepsilon_3}}$$

$$q_1 = \frac{A_1 \sigma (T_1^4 - T_3^4)}{0.667 + 1 + 49 + \left[ 0.6 + \frac{1}{\frac{1}{1.4} + \frac{1}{0.4}} \right]^{-1} + 1.5} = \frac{A_1 \sigma (T_1^4 - T_3^4)}{0.667 + 1 + 49 + 1.098 + 1.5}$$

$$q_1 = 0.0188 \left( 1.963 \times 10^{-3} \text{ m}^2 \right) 5.67 \times 10^{-8} \text{ W/m}^2 \cdot \text{K}^4 \left( 900^4 - 400^4 \right) \text{ K}^4$$

$$q_1 = 1.32 \text{ W}$$

<

**COMMENTS:** Radiation transfer from 1 to 3 is impeded and enhanced, respectively, by the radiation shield and the reradiating walls. However, the dominant contribution to the total radiative resistance is made by the shield.



### PROBLEM 13.84

**KNOWN:** Cylindrical cavity with prescribed geometry, wall emissivity, and temperature. Temperature of surroundings.

**FIND:** (a) Net radiation heat transfer from the cavity treating the bottom and sidewall as one surface. (b) Net radiation heat transfer from the cavity treating the bottom and sidewall as two separate surfaces.

**SCHEMATIC:**

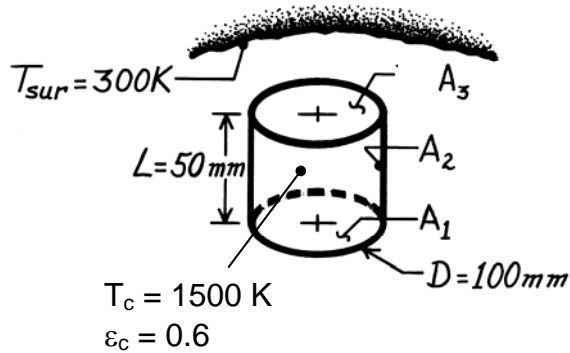

**ASSUMPTIONS:** (1) Cavity interior surfaces are diffuse-gray, (2) Surroundings are much larger than the cavity opening  $A_3$ .

**ANALYSIS:** (a) We begin by finding the relevant areas and view factors.

$$A_1 = A_3 = \pi D^2 / 4 = 7.85 \times 10^{-3} \text{ m}^2$$

$$A_2 = \pi DL = 1.57 \times 10^{-2} \text{ m}^2$$

$$A_c = A_1 + A_2 = 2.36 \times 10^{-2} \text{ m}^2$$

From Table 13.2, Coaxial Parallel Disks, with  $r_1/L = 0.050/0.050 = 1$  and  $r_3/L = 1$ , find

$$F_{13} = F_{31} = 0.382$$

Then,  $F_{32} = F_{12} = 1 - F_{13} = 0.618$

$$F_{21} = F_{23} = A_1 F_{12} / A_2 = 0.309$$

The shape factor from the combined surfaces 1 and 2 to the surroundings is

$$F_{c-s} = F_{12-3} = A_3 F_{3-12} / A_{12} = 7.85 \times 10^{-3} \text{ m}^2 \times 1 / 2.36 \times 10^{-2} \text{ m}^2 = 0.333$$

The combined surface  $A_c$  exchanges radiation with the large surroundings. The net radiation heat transfer from the cavity is given by Eq. 13.23 with  $A_2$  in that equation representing the surroundings, such that  $A_2 \rightarrow \infty$ , and the equation reduces to

$$q_A = \frac{\sigma (T_c^4 - T_{sur}^4) A_c}{\frac{1 - \epsilon_c}{\epsilon_c} + \frac{1}{F_{c-s}}} = \frac{5.67 \times 10^{-8} \text{ W/m}^2 \cdot \text{K}^4 (1500^4 - 300^4) \text{ K}^4 \times 2.36 \times 10^{-2} \text{ m}^2}{\frac{1 - 0.6}{0.6} + \frac{1}{0.333}}$$

$$q_A = 1842 \text{ W} \quad \leftarrow$$

(b) Considering surfaces 1 and 2 separately, the heat transfer from the cavity to the surroundings can be found as the heat transfer reaching hypothetical surface 3 (the cavity opening), that is,  $q_B = -q_3$ , which from Eq. 13.20 is,

$$q_3 = A_3 F_{31} (J_3 - J_1) + A_3 F_{32} (J_3 - J_2). \quad (1)$$

Continued...

### PROBLEM 13.84 (Cont.)

As noted in Example 13.4, openings of enclosures that exchange radiation with large surroundings may be treated as hypothetical, nonreflecting black surfaces ( $\epsilon_3 = 1$ ) whose temperature is equal to that of the surroundings,  $T_3 = T_{\text{sur}}$ . With  $\epsilon_3 = 1$ ,  $J_3 = E_{b3}$ . However,  $J_1$  and  $J_2$  are unknown and must be obtained from the radiation balances, Eq. 13.21,

$$\frac{E_{b1} - J_1}{(1 - \epsilon_1)/\epsilon_1 A_1} = \sum_{j=1}^N \frac{J_1 - J_j}{(A_1 F_{1j})^{-1}} \quad (2)$$

Note also,  $E_{b1} = E_{b2} = \sigma T_1^4 = \sigma (1500\text{K})^4 = 287,044 \text{ W/m}^2$  and  $J_3 = E_{b3} = \sigma T_3^4 = 459.3 \text{ W/m}^2$ .

$$\begin{aligned} A_1: \quad \frac{E_{b1} - J_1}{(1 - \epsilon_1)/\epsilon_1 A_1} &= \frac{J_1 - J_2}{(A_1 F_{12})^{-1}} + \frac{J_1 - J_3}{(A_1 F_{13})^{-1}} \\ \frac{287,044 - J_1}{(1 - 0.6)/0.6} &= \frac{J_1 - J_2}{(0.618)^{-1}} + \frac{J_1 - 459.3}{(0.382)^{-1}} \quad 2.5J_1 - 0.618J_2 = 430,741 \end{aligned} \quad (3)$$

$$\begin{aligned} A_2: \quad \frac{E_{b2} - J_2}{(1 - \epsilon_2)/\epsilon_2 A_2} &= \frac{J_2 - J_1}{(A_2 F_{21})^{-1}} + \frac{J_2 - J_3}{(A_2 F_{23})^{-1}} \\ \frac{287,044 - J_2}{(1 - 0.6)/0.6} &= \frac{J_2 - J_1}{(0.309)^{-1}} + \frac{J_2 - 459.3}{(0.309)^{-1}} \quad -0.309J_1 + 2.118J_2 = 430,708 \end{aligned} \quad (4)$$

Solving Eqs. (3) and (4) simultaneously, find  $J_1 = 230,491 \text{ W/m}^2$  and  $J_2 = 234,654 \text{ W/m}^2$ , and from Eq. (1), find

$$q_B = 7.854 \times 10^{-3} \text{ m}^2 [0.382(459.3 - 230,491) + 0.618(459.3 - 234,654)] \text{ W/m}^2$$

$$q_B = 1840 \text{ W} \quad \leftarrow$$

(c) The equations for shape factors were entered into the *IHT* workspace, along with Eqs. (1), (3), and (4). The resulting plot is shown below.

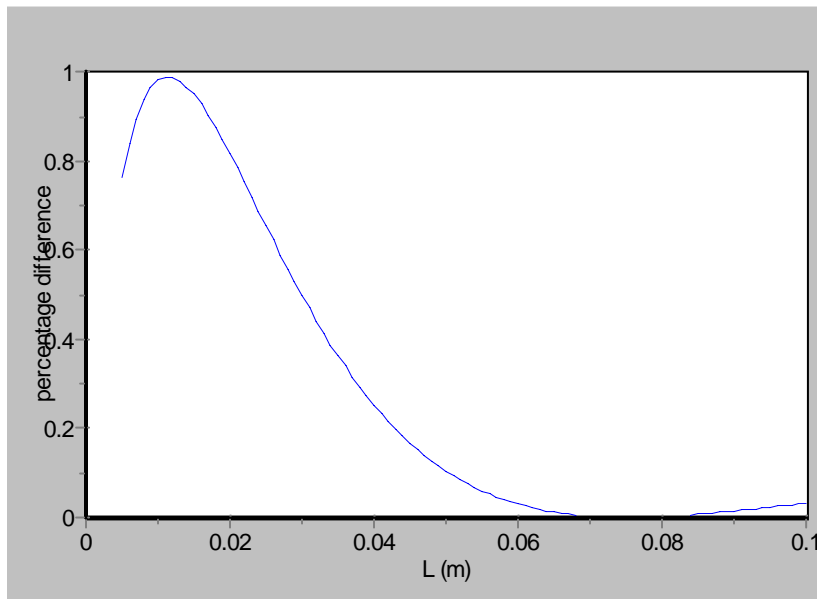

Continued...

### PROBLEM 13.84 (Cont.)

**COMMENTS:** The difference between the two different methods for calculating heat transfer rates is less than 1% over the entire range of  $L$ . When we treat the sides and bottom as one surface, we are assuming that the radiosity is the same for these two surfaces. This is exactly true when the shape factor between each of those surfaces and the environment is the same, as it is for  $L$  around 0.075 m (see below). But from the graphs we see that even when the shape factors and radiosities are not very close for the two surfaces, the net heat transfer rate can still be accurately approximated by treating both surfaces as one.

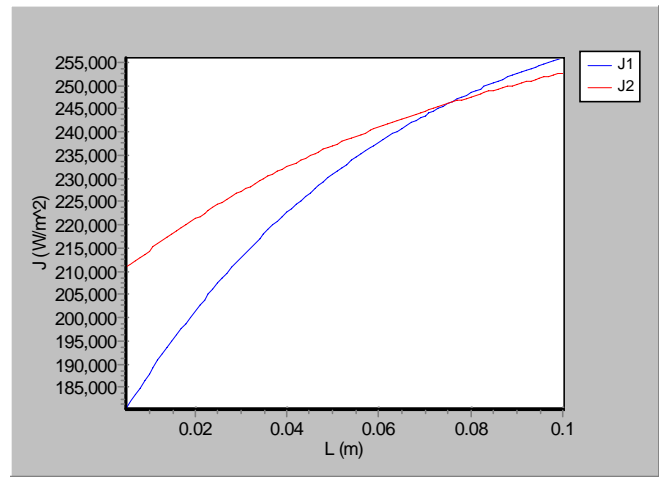
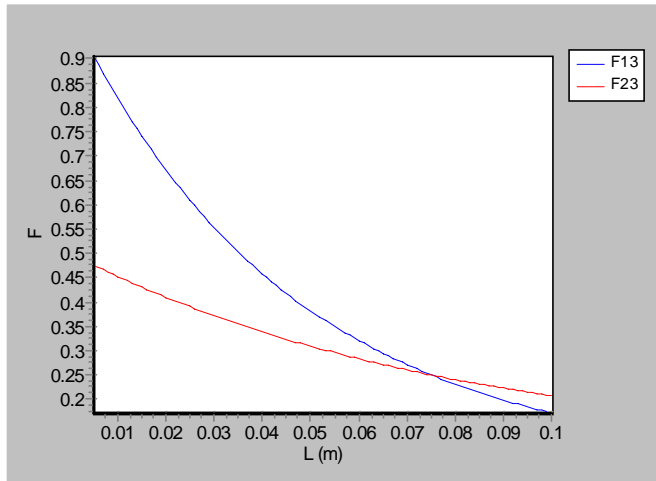

### PROBLEM 13.85

**KNOWN:** Circular furnace with prescribed temperatures and emissivities of the lateral and end surfaces.

**FIND:** Net radiative heat transfer from each surface.

**SCHEMATIC:**

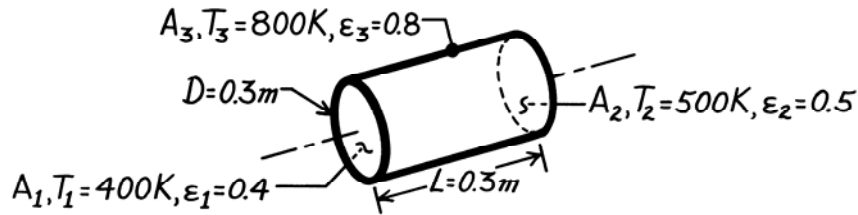

**ASSUMPTIONS:** (1) Surfaces are isothermal and diffuse-gray.

**ANALYSIS:** To calculate the net radiation heat transfer from each surface, we need to determine its radiosity. First, evaluate terms that will be required.

$$\begin{aligned}
 E_{b1} &= \sigma T_1^4 = 1452 \text{ W/m}^2 & A_1 &= A_2 = \pi D^2 / 4 = 0.07069 \text{ m}^2 & F_{12} &= F_{21} = 0.17 \\
 E_{b2} &= \sigma T_2^4 = 3544 \text{ W/m}^2 & A_3 &= \pi DL = 0.2827 \text{ m}^2 & F_{23} &= F_{13} = 0.83 \\
 E_{b3} &= \sigma T_3^4 = 23,224 \text{ W/m}^2
 \end{aligned}$$

The view factor  $F_{12}$  results from Fig. 13.5 with  $L/r_1 = 2$  and  $r_1/L = 0.5$ . The radiation balances using Eq. 13.21, omitting units for convenience, are:

$$\begin{aligned}
 A_1: \quad \frac{1452 - J_1}{(1 - 0.4)} &= 0.07069 \times 0.17 (J_1 - J_2) + 0.07069 \times 0.83 (J_1 - J_3) \\
 &= 0.4 \times 0.07069 \\
 &\quad -2.500J_1 + 0.2550J_2 + 1.2450J_3 = -1452 \quad (1)
 \end{aligned}$$

$$\begin{aligned}
 A_2: \quad \frac{3544 - J_2}{(1 - 0.5)} &= 0.07069 \times 0.17 (J_2 - J_1) + 0.07069 \times 0.83 (J_2 - J_3) \\
 &= 0.5 \times 0.07069 \\
 &\quad -0.1700J_1 - 2.0000J_2 + 0.8300J_3 = -3544 \quad (2)
 \end{aligned}$$

$$\begin{aligned}
 A_3: \quad \frac{23,224 - J_3}{(1 - 0.8)} &= 0.07069 \times 0.83 (J_3 - J_1) + 0.07069 \times 0.83 (J_3 - J_2) \\
 &= 0.8 \times 0.2827 \\
 &\quad 0.05189J_1 + 0.05189J_2 - 1.1037J_3 = -23,224 \quad (3)
 \end{aligned}$$

Solving Eqs. (1) – (3) simultaneously, find

$$J_1 = 12,877 \text{ W/m}^2 \quad J_2 = 12,086 \text{ W/m}^2 \quad J_3 = 22,216 \text{ W/m}^2.$$

Using Eq. 13.20, the net radiation heat transfer for each surface follows:

$$q_i = \sum_{j=1}^N A_i F_{ij} (J_i - J_j)$$

$$A_1: \quad q_1 = 0.07069 \times 0.17 (12,877 - 12,086) \text{ W} + 0.07069 \times 0.83 (12,877 - 22,216) \text{ W} = -538 \text{ W} <$$

$$A_2: \quad q_2 = 0.07069 \times 0.17 (12,086 - 12,877) \text{ W} + 0.07069 \times 0.83 (12,086 - 22,216) \text{ W} = -603 \text{ W} <$$

$$A_3: \quad q_3 = 0.07069 \times 0.83 (22,216 - 12,877) \text{ W} + 0.07069 \times 0.83 (22,216 - 12,086) \text{ W} = 1141 \text{ W} <$$

**COMMENTS:** Note that  $\sum q_i = 0$ . Also, note that  $J_2 < J_1$  despite the fact that  $T_2 > T_1$ ; note the role emissivity plays in explaining this.

### PROBLEM 13.86

**KNOWN:** Temperatures of two large parallel plates and desired radiation heat flux between them.

**FIND:** (a) If plate emissivities are uniform and equal, show that required emissivity is 0.5. (b) If plates are painted with checkerboard patterns having two different emissivities with an average value of 0.5, will heat flux be the desired value?

**SCHEMATIC:**

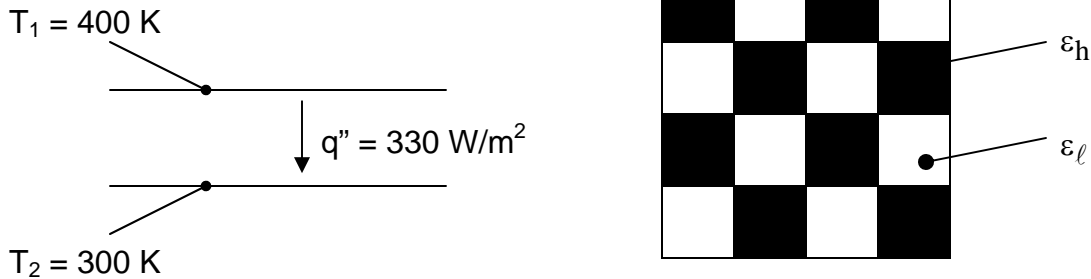

**ASSUMPTIONS:** (1) Surfaces are diffuse, (2) Plates are effectively infinite (no radiation exchange with surroundings), (3) Plate temperatures are uniform.

**ANALYSIS:** (a) The heat flux between two infinite parallel plates is given by Eq. 13.24. With  $\epsilon_1 = \epsilon_2 = 0.5$ , we find

$$q''_{12} = \frac{\sigma(T_1^4 - T_2^4)}{2/\epsilon - 1} = \frac{5.67 \times 10^{-8} \text{ W/m}^2 \cdot \text{K}^4 (400^4 - 300^4) \text{K}^4}{2/0.5 - 1} = 331 \text{ W/m}^2 \quad (1)$$

Thus, to a very close approximation, the required emissivity of the plates is 0.5. <

(b) With the checkerboard pattern, we can identify four different surfaces: the high emissivity region on the top surface (1h), the low emissivity region on the top surface (1 $\ell$ ), the high emissivity region on the bottom surface (2h), and the low emissivity region on the bottom surface (2 $\ell$ ). The view factors can be found by inspection. The view factor between a region on the top plate and a region on the bottom plate is 0.5, that is,

$$\begin{aligned} F_{1h-2h} &= 0.5, & F_{1h-2\ell} &= 0.5, & F_{1\ell-2h} &= 0.5, & F_{1\ell-2\ell} &= 0.5 \\ F_{2h-1h} &= 0.5, & F_{2h-1\ell} &= 0.5, & F_{2\ell-2h} &= 0.5, & F_{2\ell-2\ell} &= 0.5 \end{aligned}$$

and all other view factors (from a region on one plate to a region on the same plate) are zero. We proceed to write Eq. 13.21 at all four surfaces, recognizing that all regions have the same area,

Continued...

**PROBLEM 13.86 (Cont.)**

$$\frac{E_{b1} - J_{1h}}{(1 - \varepsilon_h)/\varepsilon_h} = \frac{J_{1h} - J_{2h}}{1/0.5} + \frac{J_{1h} - J_{2\ell}}{1/0.5}$$

$$\frac{E_{b1} - J_{1\ell}}{(1 - \varepsilon_\ell)/\varepsilon_\ell} = \frac{J_{1\ell} - J_{2h}}{1/0.5} + \frac{J_{1\ell} - J_{2\ell}}{1/0.5}$$

$$\frac{E_{b2} - J_{2h}}{(1 - \varepsilon_h)/\varepsilon_h} = \frac{J_{2h} - J_{1h}}{1/0.5} + \frac{J_{2h} - J_{1\ell}}{1/0.5}$$

$$\frac{E_{b2} - J_{2\ell}}{(1 - \varepsilon_\ell)/\varepsilon_\ell} = \frac{J_{2\ell} - J_{1h}}{1/0.5} + \frac{J_{2\ell} - J_{1\ell}}{1/0.5}$$

Proceeding with the algebra required to solve these four simultaneous equations results in

$$J_{1h} = \varepsilon_h E_{b1} + \frac{1 - \varepsilon_h}{2 - \bar{\varepsilon}} [E_{b2} + (1 - \bar{\varepsilon})E_{b1}]$$

$$J_{1\ell} = \varepsilon_\ell E_{b1} + \frac{1 - \varepsilon_\ell}{2 - \bar{\varepsilon}} [E_{b2} + (1 - \bar{\varepsilon})E_{b1}]$$

$$J_{2h} = \varepsilon_h E_{b2} + \frac{1 - \varepsilon_h}{2 - \bar{\varepsilon}} [E_{b1} + (1 - \bar{\varepsilon})E_{b2}]$$

$$J_{2\ell} = \varepsilon_\ell E_{b2} + \frac{1 - \varepsilon_\ell}{2 - \bar{\varepsilon}} [E_{b1} + (1 - \bar{\varepsilon})E_{b2}]$$

where  $\bar{\varepsilon} = (\varepsilon_1 + \varepsilon_2)/2$ . Then the net radiation heat flux between the two plates can be expressed as,  $q''_{\text{net}} = (q''_{1h}A_h + q''_{1\ell}A_\ell)/A_{\text{tot}} = 0.5(q''_{1h} + q''_{1\ell})$ , and making use of Eq. 13.20 for the heat fluxes, we find,

$$\begin{aligned} q''_{\text{net}} &= 0.5 \{ [0.5(J_{1h} - J_{2h}) + 0.5(J_{1h} - J_{2\ell})] + [0.5(J_{1\ell} - J_{2h}) + 0.5(J_{1\ell} - J_{2\ell})] \} \\ &= 0.5 [(J_{1h} + J_{1\ell}) - (J_{2h} + J_{2\ell})] \end{aligned}$$

After much manipulation, this reduces to

$$q''_{\text{net}} = \frac{E_{b1} - E_{b2}}{2/\bar{\varepsilon} - 1} \quad (2)$$

Comparing Eqs. (1) and (2), we see that the checkerboard pattern with an average emissivity  $\bar{\varepsilon}$  will result in the same heat flux as uniform emissivity plates with emissivity  $\varepsilon = \bar{\varepsilon}$ .

With average emissivity of 0.5, the checkerboard pattern will yield the desired heat flux. <

**COMMENTS:** An alternative to this tedious algebraic proof would be to use *IHT* to solve the four surface enclosure problem and show numerically that average emissivities of 0.5 yield the desired heat flux.

## PROBLEM 13.87

**KNOWN:** Temperature of large enclosure. Areas and emissivity of two convex objects in enclosure, and view factor between them. Power supplied to object 2. Temperature of object 1.

**FIND:** Heating or cooling rate for object 1. Temperature of object 2.

**SCHEMATIC:**

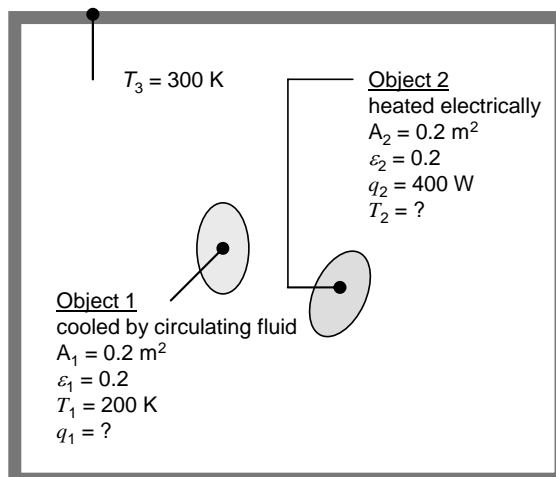

**ASSUMPTIONS:** (1) Steady-state conditions, (2) Objects are gray and diffuse, (3) Large enclosure behaves as blackbody, (4) Each surface experiences uniform irradiation and radiosity.

**ANALYSIS:** We are given  $F_{12} = 0.2$ . Since object 1 is convex, it does not see itself, and  $F_{13} = 1 - F_{12} = 0.8$ . The areas of the two objects are the same, therefore from reciprocity  $F_{21} = F_{12} = 0.2$ . Finally, since object 2 is convex,  $F_{23} = 1 - F_{21} = 0.8$ .

The enclosure is assumed to be large enough to behave as a blackbody, therefore:

$$J_3 = E_{b3} = \sigma T_3^4 = 5.67 \times 10^{-8} \text{ W/m}^2 \cdot \text{K}^4 \times 300^4 \text{ K}^4 = 459.3 \text{ W/m}^2$$

Equation 13.21 can be written at surface 1 where the temperature is known:

$$\frac{E_{b1} - J_1}{(1 - \epsilon_1) / \epsilon_1 A_1} = \frac{J_1 - J_2}{1 / A_1 F_{12}} + \frac{J_1 - J_3}{1 / A_1 F_{13}} \quad (1)$$

The power is known at surface 2,  $q_2 = 400 \text{ W}$ , so we write Equation 13.22:

$$q_2 = \frac{J_2 - J_1}{1 / A_2 F_{21}} + \frac{J_2 - J_3}{1 / A_2 F_{23}} \quad (2)$$

Substituting values into Eqs. (1) and (2) gives

$$\begin{aligned} 0.05 \text{ m}^2 (E_{b1} - J_1) &= 0.04 \text{ m}^2 (J_1 - J_2) + 0.16 \text{ m}^2 (J_1 - J_3) \\ 400 \text{ W} &= 0.04 \text{ m}^2 (J_2 - J_1) + 0.16 \text{ m}^2 (J_2 - J_3) \end{aligned}$$

where  $E_{b1} = \sigma T_1^4 = 5.67 \times 10^{-8} \text{ W/m}^2 \cdot \text{K}^4 \times 200^4 \text{ K}^4 = 90.72 \text{ W/m}^2$  and  $J_3$  is given above. Solving these two simultaneous equations yields

Continued...

### PROBLEM 13.87 (Cont.)

$$J_1 = 713.7 \text{ W/m}^2, J_2 = 2510 \text{ W/m}^2$$

The net rate of radiation leaving object 1 is given by Equation 13.19:

$$q_1 = \frac{E_{b1} - J_1}{(1 - \varepsilon_1) / \varepsilon_1 A_1} = 0.05 \text{ m}^2 (90.72 \text{ W/m}^2 - 713.7 \text{ W/m}^2) = -31.1 \text{ W} \quad <$$

There is a net rate of radiation heat transfer *to* object 1 of 31.1 W, which must be *removed* from object 1 by the coolant. <

The temperature of object 2 can be found by solving Equation 13.19 for  $E_{b2}$ :

$$E_{b2} = J_2 + q_2 \frac{1 - \varepsilon_2}{\varepsilon_2 A_2} = 2510 \text{ W/m}^2 + 400 \text{ W} \frac{1 - 0.2}{0.2 \times 0.2 \text{ m}^2} = 10,510 \text{ W/m}^2$$

Then with  $E_{b2} = \sigma T_2^4$  we find  $T_2 = 656 \text{ K}$ . <

**COMMENTS:** (1) If the objects were concave, additional information would have to be known about their shapes in order to determine the appropriate view factors. (2) The objects would clearly experience non-uniform irradiation and radiosity. A more detailed analysis would need to be performed in order to determine whether the non-uniform radiation fluxes would affect the answers. As for concave objects, a more detailed analysis of the convex objects would necessitate information regarding the shape of the objects. (3) The coolant must have a freezing point less than 200 K.



### PROBLEM 13.88

**KNOWN:** Four surface enclosure with all sides of equal area; temperatures of three surfaces are specified while the fourth is re-radiating.

**FIND:** Temperature of the re-radiating surface  $A_4$ .

**SCHEMATIC:**

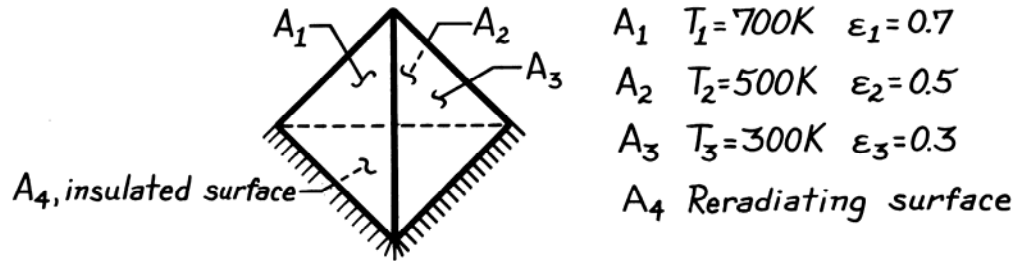

**ASSUMPTIONS:** (1) Surfaces are diffuse-gray, (2) Surfaces have uniform radiosities.

**ANALYSIS:** To determine the temperature of the re-radiating surface  $A_4$ , it is necessary to recognize that  $J_4 = E_{b4} = \sigma T_4^4$  and that the  $J_i$  ( $i = 1$  to 4) values must be evaluated by simultaneously solving four radiation balances of the form, Eq. 13.21,

$$\frac{E_{bi} - J_i}{(1 - \epsilon_i) / \epsilon_i A_i} = \sum_{j=1}^N \frac{J_i - J_j}{(A_i F_{ij})^{-1}}$$

For simplicity, set  $A_1 = A_2 = A_3 = A_4 = 1 \text{ m}^2$  and from symmetry, it follows that all view factors will be  $F_{ij} = 1/3$ . The necessary emissive powers are of the form  $E_{bi} = \sigma T_i^4$ .

$$E_{b1} = \sigma(700 \text{ K})^4 = 13,614 \text{ W/m}^2, \quad E_{b2} = \sigma(500 \text{ K})^4 = 3544 \text{ W/m}^2, \quad E_{b3} = \sigma(300 \text{ K})^4 = 459 \text{ W/m}^2.$$

The radiation balances are:

$$A_1: \frac{13,614 - J_1}{(1 - 0.7) / 0.7} = \frac{1}{3}(J_1 - J_2) + \frac{1}{3}(J_1 - J_3) + \frac{1}{3}(J_1 - J_4); -1.42857J_1 + 0.14826J_2 + 0.14826J_3 + 0.14826J_4 = -13,614$$

$$A_2: \frac{3544 - J_2}{(1 - 0.5) / 0.5} = \frac{1}{3}(J_2 - J_1) + \frac{1}{3}(J_2 - J_3) + \frac{1}{3}(J_2 - J_4) \quad 0.33333J_1 - 2.00000J_2 + 0.33333J_3 + 0.33333J_4 = -3544$$

$$A_3: \frac{459 - J_3}{(1 - 0.3) / 0.3} = \frac{1}{3}(J_3 - J_1) + \frac{1}{3}(J_3 - J_2) + \frac{1}{3}(J_3 - J_4) \quad 0.77778J_1 + 0.77778J_2 - 3.33333J_3 + 0.77778J_4 = -459$$

$$A_4: \quad 0 = \frac{1}{3}(J_4 - J_1) + \frac{1}{3}(J_4 - J_2) + \frac{1}{3}(J_4 - J_3) \quad 0.33333J_1 + 0.33333J_2 + 0.33333J_3 - 1.00000J_4 = 0$$

Solving this system of equations simultaneously, find

$$J_1 = 11,572 \text{ W/m}^2, \quad J_2 = 6031 \text{ W/m}^2, \quad J_3 = 6088 \text{ W/m}^2, \quad J_4 = 7897 \text{ W/m}^2.$$

Since the radiosity and emissive power of the re-radiating surface are equal,

$$T_4^4 = J_4 / \sigma$$

$$T_4 = \left( 7897 \text{ W/m}^2 / 5.67 \times 10^{-8} \text{ W/m}^2 \cdot \text{K}^4 \right)^{1/4} = 611 \text{ K.} \quad <$$

**COMMENTS:** Note the values of the radiosities; are their relative values what you would have expected? Is the value of  $T_4$  reasonable?

### PROBLEM 13.89

**KNOWN:** A room with electrical heaters embedded in ceiling and floor; one wall is exposed to the outdoor environment while the other three walls are to be considered as insulated.

**FIND:** Net radiation heat transfer from each surface.

**SCHEMATIC:**

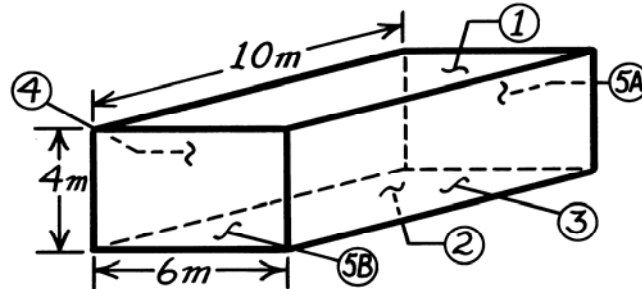

**ASSUMPTIONS:** (1) Diffuse-gray surfaces, (2) Surfaces are isothermal and irradiated uniformly, (3) Negligible convection effects, (4)  $A_5 = A_{5A} + A_{5B}$ .

**ANALYSIS:** To determine the net radiation heat transfer from each surface, find the surface radiosities using Eq. 13.20.

$$q_i = \sum_{j=1}^5 A_i F_{ij} (J_i - J_j) \quad (1)$$

To determine the value of  $J_i$ , energy balances must be written for each of the five surfaces. For surfaces 1, 2, and 3, the form is given by Eq. 13.21.

$$\frac{E_{bi} - J_i}{(1 - \epsilon_i) / \epsilon_i A_i} = \sum_{j=1}^5 \frac{J_i - J_j}{(A_i F_{ij})^{-1}} \quad i = 1, 2, \text{ and } 3. \quad (2)$$

For the insulated or adiabatic surfaces, Eq. 13.22 is appropriate with  $q_i = 0$ ; that is

$$q_i = \sum_{j=1}^N \frac{J_i - J_j}{(A_i F_{ij})^{-1}} = 0 \quad i = 4 \text{ and } 5. \quad (3)$$

In order to write the energy balances by Eq. (2) and (3), we will need to know view factors. Using Fig. 13.4 (parallel rectangles) or Fig. 13.5 (perpendicular rectangles) find:

$$\begin{aligned} F_{12} = F_{21} = 0.39 & & X/L = 10/4 = 2.5, & & Y/L = 6/4 = 1.5 \\ F_{13} = F_{14} = 0.19 & & Z/X = 4/10 = 0.4, & & Y/X = 6/10 = 0.6 \\ F_{34} = F_{43} = 0.19 & & X/L = 10/6 = 1.66, & & Y/L = 4/6 = 0.67 \\ F_{24} = F_{13} = 0.19 & & Z/X = 4/10 = 0.4, & & Y/X = 6/10 = 0.6 \end{aligned}$$

Note the use of symmetry in the above relations. Using reciprocity, find,

$$\begin{aligned} F_{32} = \frac{A_2}{A_3} F_{23} = \frac{A_2}{A_3} F_{13} = \frac{60}{40} \times 0.19 = 0.285; & & F_{31} = \frac{A_1}{A_3} F_{13} = \frac{60}{40} \times 0.19 = 0.285 \\ F_{51} = \frac{A_1}{A_5} F_{15} = \frac{60}{48} \times 0.23 = 0.288; & & F_{53} = \frac{A_3}{A_5} F_{35} = \frac{40}{48} \times 0.25 = 0.208. \end{aligned}$$

From the summation view factor relation,

$$\begin{aligned} F_{15} = 1 - F_{12} - F_{13} - F_{14} = 1 - 0.39 - 0.19 - 0.19 = 0.23 \\ F_{35} = 1 - F_{31} - F_{32} - F_{34} = 1 - 0.285 - 0.285 - 0.19 = 0.24 \end{aligned}$$

Continued ...

### PROBLEM 13.89 (Cont.)

Using Eq. (2), now write the energy balances for surfaces 1, 2, and 3. (Note  $E_b = \sigma T^4$ ).

$$\frac{544.2 - J_1}{1 - 0.8/0.8 \times 60} = \frac{J_1 - J_2}{1/60 \times 0.39} + \frac{J_1 - J_3}{1/60 \times 0.19} + \frac{J_1 - J_4}{1/60 \times 0.19} + \frac{J_1 - J_5}{1/60 \times 0.23}$$

$$-1.2500J_1 + 0.0975J_2 + 0.0475J_3 + 0.570J_5 = -544.2 \quad (4)$$

$$\frac{617.2 - J_2}{1 - 0.9/0.9 \times 60} = \frac{J_2 - J_1}{1/60 \times 0.39} + \frac{J_2 - J_3}{1/60 \times 0.19} + \frac{J_2 - J_4}{1/60 \times 0.19} + \frac{J_2 - J_5}{1/60 \times 0.23}$$

$$+0.0433J_1 - 1.111J_2 + 0.02111J_3 + 0.02111J_4 + 0.02556J_5 = -617.2 \quad (5)$$

$$\frac{390.1 - J_3}{1 - 0.7/0.7 \times 40} = \frac{J_3 - J_1}{1/40 \times 0.285} + \frac{J_3 - J_2}{1/40 \times 0.285} + \frac{J_3 - J_4}{1/40 \times 0.19} + \frac{J_3 - J_5}{1/40 \times 0.24}$$

$$+0.1221J_1 + 0.1221J_2 - 1.4284J_3 + 0.08143J_4 + 0.1028J_5 = -390.1 \quad (6)$$

Using Eq. (3), now write the energy balances for surfaces 4 and 5 noting  $q_4 = q_5 = 0$ .

$$0 = \frac{J_4 - J_1}{1/40 \times 0.285} + \frac{J_4 - J_2}{1/40 \times 0.285} + \frac{J_4 - J_3}{1/40 \times 0.19} + \frac{J_4 - J_5}{1/40 \times 0.24}$$

$$0.285J_1 + 0.285J_2 + 0.19J_3 - 1.0J_4 + 0.24J_5 = 0 \quad (7)$$

$$0 = \frac{J_5 - J_1}{1/48 \times 0.288} + \frac{J_5 - J_2}{1/48 \times 0.288} + \frac{J_5 - J_3}{1/48 \times 0.208} + \frac{J_5 - J_4}{1/48 \times 0.208}$$

$$0.288J_1 + 0.288J_2 + 0.208J_3 + 0.208J_4 - 0.992J_5 = 0 \quad (8)$$

Note that Eqs. (4) – (8) represent a set of simultaneous equations which can be written in matrix notation. That is,  $[A][J] = [C]$  with

$$A = \begin{bmatrix} -1.250 & 0.0975 & 0.0475 & 0.0475 & 0.0575 \\ 0.0433 & -1.111 & 0.02111 & 0.02111 & 0.02556 \\ 0.1221 & 0.1221 & -1.4284 & 0.08143 & 0.1028 \\ 0.285 & 0.285 & 0.190 & -1.000 & 0.240 \\ 0.288 & 0.288 & 0.208 & 0.208 & -0.992 \end{bmatrix} \quad C = \begin{bmatrix} -544.2 \\ -617.2 \\ -390.1 \\ 0 \\ 0 \end{bmatrix} \quad J = \begin{bmatrix} 545.1 \\ 607.9 \\ 441.5 \\ 542.3 \\ 541.0 \end{bmatrix} \quad \text{W/m}^2$$

where the  $J_i$  were found using IHT. The net radiation heat transfer from each of the surfaces can now be evaluated using Eq. (1).

$$q_1 = A_1 F_{12}(J_1 - J_2) + A_1 F_{13}(J_1 - J_3) + A_1 F_{14}(J_1 - J_4) + A_1 F_{15}(J_1 - J_5)$$

$$q_1 = 60 \text{ m}^2 [0.39(545.1 - 607.9)$$

$$+ 0.19(545.1 - 441.5) + 0.19(545.1 - 542.3) + 0.23(545.1 - 541.0)] \text{ W/m}^2 = -200 \text{ W} <$$

$$q_2 = 60 \text{ m}^2 [0.39(607.9 - 545.1)$$

$$+ 0.19(607.9 - 441.5) + 0.19(607.9 - 542.3) + 0.23(607.9 - 541.0)] \text{ W/m}^2 = 5037 \text{ W} <$$

$$q_3 = 40 \text{ m}^2 [0.285(441.5 - 545.1) + 0.285(441.5 - 607.9)$$

$$+ 0.19(441.5 - 542.3) + 0.24(441.5 - 541.0)] \text{ W/m}^2 = -4,799 \text{ W} <$$

Since  $A_4$  and  $A_5$  are insulated (adiabatic),  $q_4 = q_5 = 0$ . <

**COMMENTS:** (1) Note that the sum of  $q_1 + q_2 + q_3 = +38 \text{ W}$ ; this indicates a precision of less than 1% resulted from the solution of the equations. (2) The net radiation for the ceiling,  $A_1$ , is into the surface. Recognize that the embedded heaters function to offset heat losses to the room air by convection.

### PROBLEM 13.90

**KNOWN:** Cylindrical furnace of diameter  $D = 90$  mm and overall length  $L = 180$  mm. Heating elements maintain the refractory lining ( $\varepsilon = 0.8$ ) of section (1),  $L_1 = 135$  mm, at  $T_1 = 800^\circ\text{C}$ . The bottom (2) and upper (3) sections are refractory lined, but are insulated. Furnace operates in a spacecraft environment.

**FIND:** Power required to maintain the furnace operating conditions with the surroundings at  $23^\circ\text{C}$ .

**SCHEMATIC:**

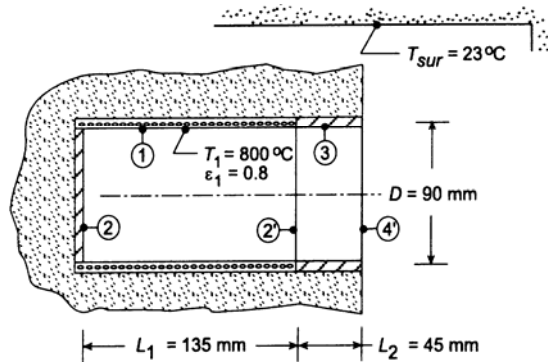

**ASSUMPTIONS:** (1) All surfaces are diffuse gray, (2) Uniform radiosity over the sections 1, 2, and 3, and (3) Negligible convection effects.

**ANALYSIS:** By defining the furnace opening as the hypothetical area  $A_4$ , the furnace can be represented as a four-surface enclosure as illustrated above. The power required to maintain  $A_1$  at  $T_1$  is  $q_1$ , the net radiation leaving  $A_1$ . To obtain  $q_1$  following the methodology of Section 13.3.2, we must determine the radiosity at all surfaces by simultaneously solving the radiation energy balance equations for each surface which will be of the form, Eqs. 13.20 or 13.21.

$$q_1 = \frac{E_{b1} - J_1}{(1 - \varepsilon_1) / \varepsilon_1 A_1} = \sum_{j=1}^N \frac{J_j - J_1}{1 / A_1 F_{1j}} \quad (1,2)$$

Since  $\varepsilon_4 = 1$ ,  $J_4 = E_{b4}$ , so we only need to perform three energy balances, for  $A_1$ ,  $A_2$ , and  $A_3$ , respectively

$$A_1: \quad \frac{E_{b1} - J_1}{(1 - \varepsilon_1) / \varepsilon_1 A_1} = \frac{J_1 - J_2}{1 / A_1 F_{12}} + \frac{J_1 - J_3}{1 / A_1 F_{13}} + \frac{J_1 - J_4}{1 / A_1 F_{14}} \quad (3)$$

$$A_2: \quad 0 = \frac{J_2 - J_1}{1 / A_2 F_{21}} + \frac{J_2 - J_3}{1 / A_2 F_{23}} + \frac{J_2 - J_4}{1 / A_2 F_{24}} \quad (4)$$

$$A_3: \quad 0 = \frac{J_3 - J_1}{1 / A_3 F_{31}} + \frac{J_3 - J_2}{1 / A_3 F_{32}} + \frac{J_3 - J_4}{1 / A_3 F_{34}} \quad (5)$$

Note that  $q_2 = q_3 = 0$  since the surfaces are insulated (adiabatic). Recognize that in the above equation set, there are three equations and three unknowns:  $J_1$ ,  $J_2$ , and  $J_3$ . From knowledge of  $J_1$ ,  $q_1$  can be determined using Eq. (1). Next we need to evaluate the view factors. There are  $N^2 = 4^2 = 16$  view factors and  $N(N - 1) / 2 = 6$  must be independently evaluated, while the remaining can be determined by the summation rule and appropriate reciprocity relations. The six independently determined  $F_{ij}$  are:

By inspection: (1)  $F_{22} = 0$                       (2)  $F_{44} = 0$

Coaxial parallel disks: From Fig. 13.5 or Table 13.5,

Continued ...

**PROBLEM 13.90 (Cont.)**

$$F_{24} = 0.5 \left\{ S - \left[ S^2 - 4(r_4 / r_2)^2 \right]^{1/2} \right\}$$

$$(3) \quad F_{24} = 0.5 \left\{ 18 - \left[ 18^2 - 4(1)^2 \right]^{1/2} \right\} = 0.05573$$

$$S = 1 + \frac{1 + R_4^2}{R_2^2} = 1 + \frac{1 + 0.250^2}{0.250^2} = 18.00 \quad R_2 = r_2 / L = 45 / 180 = 0.250 \quad R_4 = r_4 / L = 0.250$$

Enclosure 1-2-2': from the summation rule for A<sub>2</sub>,

$$(4) \quad F_{21} = 1 - F_{22'} = 1 - 0.09167 = 0.9083$$

where F<sub>22'</sub> can be evaluated from the coaxial parallel disk relation, Table 13.5. For these surfaces, R<sub>2</sub> = r<sub>2</sub>/L<sub>1</sub> = 45/135 = 0.333, R<sub>2'</sub> = r<sub>2</sub>/L<sub>1</sub> = 0.333, and S = 11.00. From the summation rule for A<sub>1</sub>,

$$(5) \quad F_{11} = 1 - F_{12} - F_{12'} = 1 - 0.1514 - 0.1514 = 0.6972$$

and by symmetry F<sub>12</sub> = F<sub>12'</sub> and using reciprocity

$$F_{12} = A_2 F_{21} / A_1 = [\pi(0.090\text{m})(2/4)] \times 0.9083 / \pi \times 0.090\text{m} \times 0.135\text{m} = 0.1514$$

Enclosure 2'-3-4: from the summation rule for A<sub>4</sub>,

$$(6) \quad F_{43} = 1 - F_{42'} - F_{44} = 1 - 0.3820 - 0 = 0.6180$$

where F<sub>44</sub> = 0 and using the coaxial parallel disk relation from Table 13.5, with R<sub>4</sub> = r<sub>4</sub>/L<sub>2</sub> = 45/45 = 1, R<sub>2'</sub> = r<sub>2</sub>/L<sub>2</sub> = 1, and S = 3.

The View Factors: Using summation rules and appropriate reciprocity relations, the remaining 10 view factors can be evaluated. Written in matrix form, the F<sub>ij</sub> are

0.6972*	0.1514	0.09704	0.05438	
0.9083*	0*	0.03597	0.05573*	
0.2911		0.017980.3819		0.3090
0.3262		0.055730.6180*	0*	

The F<sub>ij</sub> shown with an asterisk were independently determined.

From knowledge of the relevant view factors, the energy balances, Eqs. (3, 4, 5), can be solved simultaneously to obtain the radiosities,

$$J_1 = 73,084 \text{ W/m}^2 \quad J_2 = 67,723 \text{ W/m}^2 \quad J_3 = 36,609 \text{ W/m}^2$$

The net heat rate leaving A<sub>1</sub> can be evaluated using Eq. (1) written as

$$q_1 = \frac{E_{b1} - J_1}{(1 - \varepsilon_1) / \varepsilon_1 A_1} = \frac{(75,159 - 73,084) \text{ W/m}^2}{(1 - 0.8) / 0.8 \times 0.03817 \text{ m}^2} = 317 \text{ W} \quad <$$

where E<sub>b1</sub> = σT<sub>1</sub><sup>4</sup> = σ(800 + 273K)<sup>4</sup> = 75,159 W/m<sup>2</sup> and A<sub>1</sub> = πDL<sub>1</sub> = π × 0.090m × 0.135m = 0.03817 m<sup>2</sup>.

**COMMENTS:** (1) Recognize the importance of defining the furnace opening as the hypothetical area A<sub>4</sub> which completes the four-surface enclosure representing the furnace. The temperature of A<sub>4</sub> is that of the surroundings and its emissivity is unity since it absorbs all radiation incident on it. (2) To obtain the view factor matrix, we used the *IHT Tool, Radiation, View Factor Relations*, which permits you to specify the independently determined F<sub>ij</sub> and the tool will calculate the remaining ones.

### PROBLEM 13.91

**KNOWN:** Dimensions of furnace. Emissivity of surfaces. Temperatures of furnace walls and surroundings.

**FIND:** Rate of radiation heat transfer to surroundings.

**SCHEMATIC:**

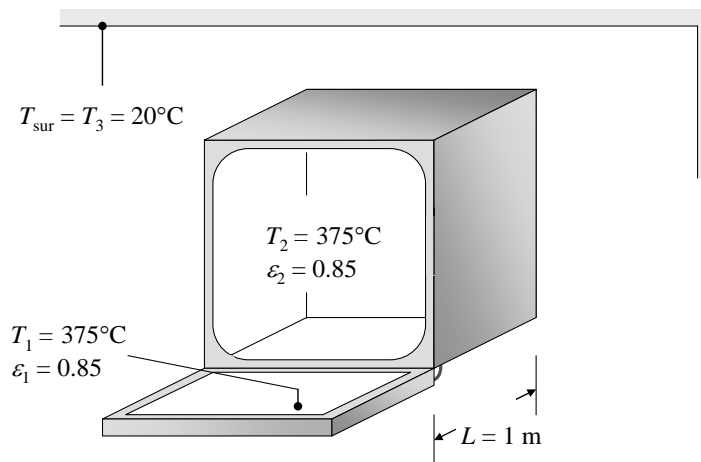

**ASSUMPTIONS:** (1) Surfaces are gray and diffuse, (2) Surroundings behave as blackbody, (3) Outer surface of furnace is adiabatic, (4) Each identified surface has uniform irradiation and radiosity.

**ANALYSIS:** The surrounding room is assumed to be large enough to behave as a blackbody, therefore:

$$J_3 = E_{b3} = \sigma T_3^4 = 5.67 \times 10^{-8} \text{ W/m}^2 \cdot \text{K}^4 \times (20 + 273)^4 \text{ K}^4 = 417.9 \text{ W/m}^2$$

The temperature of the oven surfaces is known, therefore we can write Equation 13.21 for surfaces 1 and 2.

$$\frac{E_{b1} - J_1}{(1 - \epsilon_1) / \epsilon_1 A_1} = \frac{J_1 - J_2}{1 / A_1 F_{12}} + \frac{J_1 - J_3}{1 / A_1 F_{13}} \quad (1)$$

$$\frac{E_{b2} - J_2}{(1 - \epsilon_2) / \epsilon_2 A_2} = \frac{J_2 - J_1}{1 / A_2 F_{21}} + \frac{J_2 - J_3}{1 / A_2 F_{23}} \quad (2)$$

The view factor from the oven door (1) to the interior walls of the furnace (2) is the same as from the oven door to the furnace opening. From Table 13.2, 3<sup>rd</sup> entry, with  $X = Y = Z = 1\text{ m}$ , we find  $H = W = 1$  and  $F_{12} = 0.2$ . Then  $F_{13} = 1 - F_{12} = 0.8$ . From reciprocity,  $F_{21} = A_1 F_{12} / A_2 = F_{12} / 5 = 0.04$ .

The view factor from the interior of the furnace (2) to the surroundings (3) can be found from the following reasoning. The radiation which leaves the interior and reaches either the oven door or the surroundings must have passed through the opening, so it will be useful to know the view factor  $F_{2o}$ , where subscript  $o$  represents the opening. We know that  $F_{o2} = 1$ , therefore from reciprocity,  $F_{2o} = A_o F_{o2} / A_2 = 1/5 = 0.2$ . The radiation that leaves through the opening must go either to the oven door or the surroundings, therefore  $F_{2o} = F_{21} + F_{23}$ . Finally then,  $F_{23} = F_{2o} - F_{21} = 0.16$ . Substituting numbers into Eqs. (1) and (2) gives

Continued...

### PROBLEM 13.91 (Cont.)

$$5.67 \text{ m}^2(E_{b1} - J_1) = 0.2 \text{ m}^2(J_1 - J_2) + 0.8 \text{ m}^2(J_1 - 417.9 \text{ W/m}^2)$$

$$28.3 \text{ m}^2(E_{b2} - J_2) = 0.2 \text{ m}^2(J_2 - J_1) + 0.8 \text{ m}^2(J_2 - 417.9 \text{ W/m}^2)$$

where  $E_{b1} = E_{b2} = \sigma T_1^4 = 5.67 \times 10^{-8} \text{ W/m}^2 \cdot \text{K}^4 \times (375 + 273)^4 \text{ K}^4 = 9997 \text{ W/m}^2$ . Solving these two simultaneous equations yields

$$J_1 = 8840 \text{ W/m}^2, J_2 = 9728 \text{ W/m}^2$$

Then the radiation heat transfer to the room can be found by summing the contributions from surfaces 1 and 2:

$$\begin{aligned} q_{\text{room}} = -q_3 &= A_1 F_{13}(J_1 - J_3) + A_2 F_{23}(J_2 - J_3) \\ &= 0.8 \text{ m}^2(8840 \text{ W/m}^2 - 417.9 \text{ W/m}^2) + 0.8 \text{ m}^2(9728 \text{ W/m}^2 - 417.9 \text{ W/m}^2) = 1.42 \times 10^4 \text{ W} < \end{aligned}$$

**COMMENTS:** Subdividing the surfaces into smaller regions in order to more closely satisfy the assumption of uniform irradiation and radiosity would provide a more accurate answer.

## PROBLEM 13.92

**KNOWN:** Observation cabin located in a hot-strip mill directly over the line; cabin floor (f) exposed to steel strip (ss) at  $T_{ss} = 920^\circ\text{C}$  and to mill surroundings at  $T_{sur} = 80^\circ\text{C}$ .

**FIND:** Coolant system heat removal rate required to maintain the cabin floor at  $T_f = 50^\circ\text{C}$  for the following conditions: (a) when the floor is directly exposed to the steel strip and (b) when a radiation shield (s)  $\varepsilon_s = 0.10$  is installed between the floor and the strip.

**SCHEMATIC:**

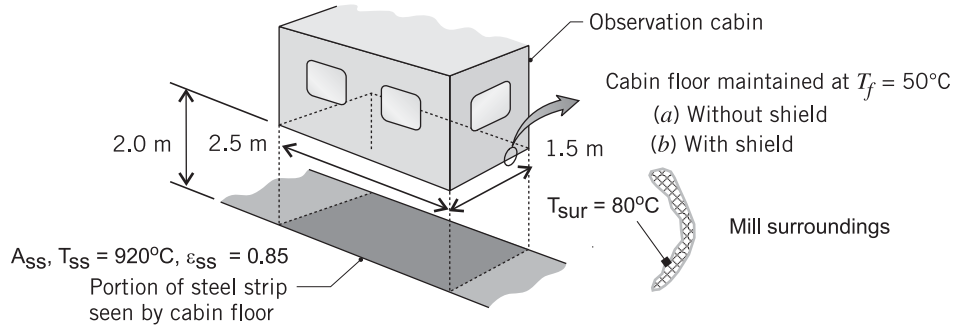

**ASSUMPTIONS:** (1) Cabin floor (f) or shield (s), steel strip (ss), and mill surroundings (sur) form a three-surface, diffuse-gray enclosure, (2) Surfaces with uniform radiosities, (3) Mill surroundings are isothermal, black, (4) Floor-shield configuration treated as infinite parallel planes, and (5) Negligible convection heat transfer to the cabin floor.

**ANALYSIS:** A gray-diffuse, three-surface enclosure is formed by the cabin floor (f) (or radiation shield, s), steel strip (ss), and the mill surroundings (sur). The heat removal rate required to maintain the cabin floor at  $T_f = 50^\circ\text{C}$  is equal to  $-q_f$  (or,  $-q_s$ ), where  $q_f$  or  $q_s$  is the net radiation leaving the floor or shield. The schematic below represents the details of the surface energy balance on the floor and shield for the conditions *without the shield* (floor exposed) and *with the shield* (floor shielded from strip).

(a) Without shield

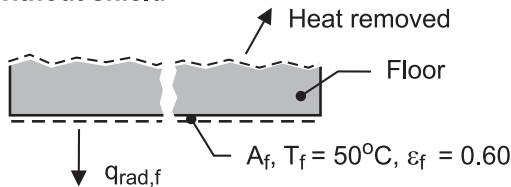

(b) With shield

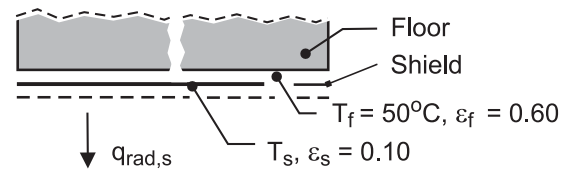

(a) *Without the shield.* Radiation surface energy balances, Eq. 13.21, are written for the floor (f) and steel strip (ss) surfaces to determine their radiosities.

$$\frac{E_{b,f} - J_f}{(1 - \varepsilon_f) / \varepsilon_f A_f} = \frac{J_f - J_{ss}}{1 / A_f F_{f-ss}} + \frac{J_f - E_{b,sur}}{1 / A_f F_{f-sur}} \quad (1)$$

$$\frac{E_{b,ss} - J_{ss}}{(1 - \varepsilon_{ss}) / \varepsilon_{ss} A_{ss}} = \frac{J_{ss} - J_f}{1 / A_{ss} F_{ss-f}} + \frac{J_{ss} - E_{b,sur}}{1 / A_{ss} F_{ss-sur}} \quad (2)$$

Since the surroundings (sur) are black,  $J_{sur} = E_{b,sur}$ . The blackbody emissive powers are expressed as  $E_b = \sigma T^4$  where  $\sigma = 5.67 \times 10^{-8} \text{ W/m}^2 \cdot \text{K}^4$ . The net radiation leaving the floor, Eq. 13.20, is

$$q_f = A_f F_{f-ss} (J_f - J_{ss}) + A_f F_{f-sur} (J_f - E_{b,sur}) \quad (3)$$

Continued ...



### PROBLEM 13.92 (Cont.)

The required view factors for the analysis are contained in the summation rule for the areas  $A_f$  and  $A_{ss}$ ,

$$F_{f-ss} + F_{f-sur} = 1 \qquad F_{ss-f} + F_{ss-sur} = 1 \qquad (4,5)$$

$F_{f-ss}$  can be evaluated from Fig. 13.4 (Table 13.2) for the aligned parallel rectangles geometry. By symmetry,  $F_{ss-f} = F_{f-ss}$ , and with the summation rule, all the view factors are determined. Using the foregoing relations in the *IHT* workspace, the following results were obtained:

$$F_{f-ss} = 0.1864 \qquad J_f = 7959 \text{ W/m}^2$$

$$F_{f-sur} = 0.8136 \qquad J_{ss} = 97.96 \text{ kW/m}^2$$

and the heat removal rate required of the coolant system (cs) is

$$q_{cs} = -q_f = 41.3 \text{ kW} \qquad <$$

(b) *With the shield.* Radiation surface energy balances are written for the shield (s) and steel strip (ss) to determine their radiosities.

$$\frac{E_{b,s} - J_s}{(1 - \varepsilon_s) / \varepsilon_s A_s} = \frac{J_s - J_{ss}}{1 / A_s F_{s-ss}} + \frac{J_s - E_{b,sur}}{1 / A_s F_{s-sur}} \qquad (6)$$

$$\frac{E_{b,ss} - J_{ss}}{(1 - \varepsilon_{ss}) / \varepsilon_{ss} A_{ss}} = \frac{J_{ss} - J_s}{1 / A_{ss} F_{ss-s}} + \frac{J_{ss} - E_{b,sur}}{1 / A_{ss} F_{ss-sur}} \qquad (7)$$

The net radiation leaving the shield is

$$q_s = A_{ss} F_{ss-s} (J_{ss} - J_s) + A_{ss} F_{ss-sur} (J_{ss} - E_{b,sur}) \qquad (8)$$

Since the temperature of the shield is unknown, an additional relation is required. The heat transfer from the shield (s) to the floor (f) - the coolant heat removal rate - is

$$-q_s = \frac{\sigma (T_s^4 - T_f^4) A_s}{1 - 1 / \varepsilon_s - 1 / \varepsilon_f} \qquad (9)$$

where the floor-shield configuration is that of infinite parallel planes, Eq. 13.24. Using the foregoing relations in the *IHT* workspace, with appropriate view factors from part (a), the following results were obtained

$$J_s = 18.13 \text{ kW/m}^2 \qquad J_{ss} = 98.20 \text{ kW/m}^2 \qquad T_s = 377^\circ\text{C}$$

and the heat removal rate required of the coolant system is

$$q_{cs} = -q_s = 6.55 \text{ kW} \qquad <$$

**COMMENTS:** The effect of the shield is to reduce the coolant system heat rate by a factor of nearly seven. Maintaining the integrity of the reflecting shield ( $\varepsilon_s = 0.10$ ) operating at nearly  $400^\circ\text{C}$  in the mill environment to prevent corrosion or oxidation may be necessary.

### PROBLEM 13.93

**KNOWN:** Dimensions of furnace and sphere. Emissivity of surfaces. Power supplied to floor of furnace. Temperature of other five walls. Sphere temperature.

**FIND:** (a) View factors  $F_{12}$ ,  $F_{13}$ ,  $F_{21}$ ,  $F_{31}$ ,  $F_{23}$ ,  $F_{32}$ , and  $F_{33}$ . (b) Temperature of floor. Net rate of radiation heat transfer leaving sphere. Whether the sphere is under steady-state conditions.

**SCHEMATIC:**

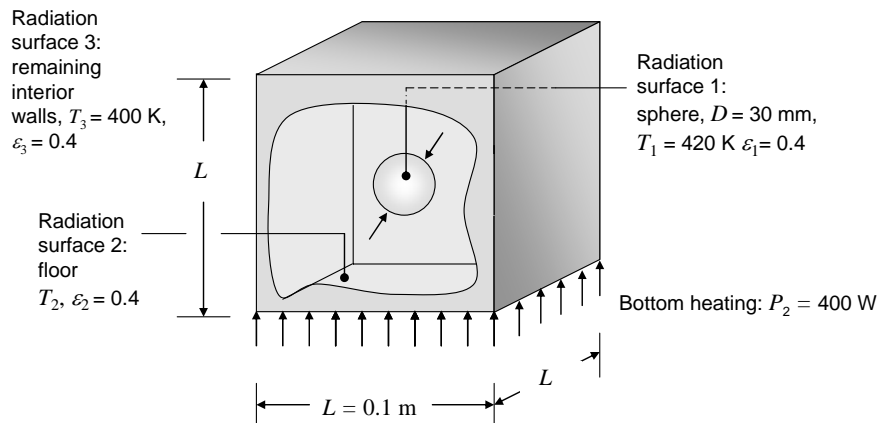

**ASSUMPTIONS:** (1) Surfaces are gray and diffuse, (2) Each identified surface has uniform irradiation and radiosity, (3) Outer surface of furnace floor is insulated and all power supplied to heater leaves as radiation into furnace (no storage), (4) Convection can be neglected.

**ANALYSIS:** (a) Due to symmetry, the view factor from the sphere to each of the six furnace walls must be equal, therefore  $F_{12} = 1/6$  and  $F_{13} = 5/6$ . <

From reciprocity,

$$F_{21} = \frac{A_1 F_{12}}{A_2} = \frac{\pi (0.03 \text{ m})^2}{6 \times (0.1 \text{ m})^2} = 0.0471 \quad <$$

$$F_{31} = \frac{A_1 F_{13}}{A_3} = \frac{5\pi (0.03 \text{ m})^2}{6 \times 5 \times (0.1 \text{ m})^2} = 0.0471 \quad <$$

Since surface 2 does not see itself,  $F_{21} + F_{23} = 1$ , therefore  $F_{23} = 1 - F_{21} = 0.953$ . <

From reciprocity,

$$F_{32} = \frac{A_2 F_{23}}{A_3} = \frac{(0.1 \text{ m})^2 \times 0.953}{5 \times (0.1 \text{ m})^2} = 0.191 \quad <$$

Finally,  $F_{33} = 1 - F_{31} - F_{32} = 0.762$ . <

(b) Equation 13.21 can be written at surfaces 1 and 3 where temperature is known:

$$\frac{E_{b1} - J_1}{(1 - \epsilon_1) / \epsilon_1 A_1} = \frac{J_1 - J_2}{1 / A_1 F_{12}} + \frac{J_1 - J_3}{1 / A_1 F_{13}} \quad (1)$$

Continued...

**PROBLEM 13.93 (Cont.)**

$$\frac{E_{b3} - J_3}{(1 - \varepsilon_3) / \varepsilon_3 A_3} = \frac{J_3 - J_1}{1 / A_3 F_{31}} + \frac{J_3 - J_2}{1 / A_3 F_{32}} \quad (2)$$

The power is known at surface 2,  $q_2 = P = 400 \text{ W}$ , so we write Equation 13.22:

$$q_2 = \frac{J_2 - J_1}{1 / A_2 F_{21}} + \frac{J_2 - J_3}{1 / A_2 F_{23}} \quad (3)$$

Substituting numbers into Eqs. (1) – (3) gives

$$\begin{aligned} 0.00189 \text{ m}^2 (E_{b1} - J_1) &= 0.000471 \text{ m}^2 (J_1 - J_2) + 0.00236 \text{ m}^2 (J_1 - J_3) \\ 0.0333 \text{ m}^2 (E_{b3} - J_3) &= 0.00236 \text{ m}^2 (J_3 - J_1) + 0.00953 \text{ m}^2 (J_3 - J_2) \\ 400 \text{ W} &= 0.000471 \text{ m}^2 (J_2 - J_1) + 0.00953 \text{ m}^2 (J_2 - J_3) \end{aligned}$$

where  $E_{b1} = \sigma T_1^4 = 5.67 \times 10^{-8} \text{ W/m}^2 \cdot \text{K}^4 \times (420)^4 \text{ K}^4 = 1764 \text{ W/m}^2$  and  $E_{b3} = \sigma T_3^4 = 5.67 \times 10^{-8} \text{ W/m}^2 \cdot \text{K}^4 \times (400)^4 \text{ K}^4 = 1452 \text{ W/m}^2$ . Solving these three simultaneous equations yields

$$J_1 = 1.24 \times 10^4 \text{ W/m}^2, J_2 = 5.28 \times 10^4 \text{ W/m}^2, J_3 = 1.29 \times 10^4 \text{ W/m}^2$$

The temperature of the floor can be found by solving Equation 13.19 for  $E_{b2}$ :

$$E_{b2} = J_2 + q_2 \frac{1 - \varepsilon_2}{\varepsilon_2 A_2} = 5.28 \times 10^4 \text{ W/m}^2 + 400 \text{ W} \frac{1 - 0.4}{0.4 \times (0.1 \text{ m})^2} = 1.128 \times 10^5 \text{ W/m}^2$$

Then with  $E_{b2} = \sigma T_2^4$  we find  $T_2 = 1188 \text{ K}$ . <

The net rate of radiation leaving the sphere surface 1 is given by Equation 13.19:

$$q_1 = \frac{E_{b1} - J_1}{(1 - \varepsilon_1) / \varepsilon_1 A_1} = 0.00189 \text{ m}^2 (1764 \text{ W/m}^2 - 1.24 \times 10^4 \text{ W/m}^2) = -20 \text{ W} \quad <$$

Since this is negative, heat is reaching the sphere at the rate of 20 W.

Since the sphere is not being heated or cooled by any mechanism other than radiation, at steady-state the net radiation heat transfer rate must be zero. Since it is not zero, it is not at steady-state. <

**COMMENTS:** (1) The bottom surface is very hot. (2) The irradiation and radiosity distributions on the spherical object are highly non-uniform. A more accurate treatment would include the effects of this non-uniformity by considering many additional radiation surfaces, as well as possible spatial temperature distributions within the spherical object. (3) The net heat radiation leaving surface 1 is relatively small and could be of the same magnitude as any convection effects.

### PROBLEM 13.94

**KNOWN:** Opaque, diffuse-gray plate with  $\epsilon_1 = 0.8$  is at  $T_1 = 400$  K at a particular instant. The bottom surface of the plate is subjected to radiative exchange with a furnace. The top surface is subjected to ambient air and large surroundings.

**FIND:** (a) Net radiative heat transfer to the bottom surface of the plate for  $T_1 = 400$  K, (b) Change in temperature of the plate with time,  $dT_1/dt$ , and (c) Compute and plot  $dT_1/dt$  as a function of  $T_1$  for the range  $350 \leq T_1 \leq 900$  K; determine the steady-state temperature of the plate.

**SCHEMATIC:**

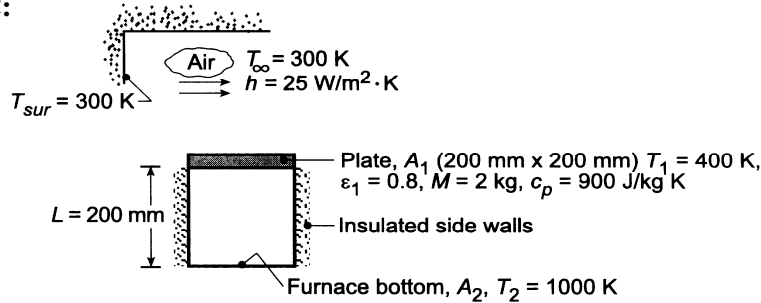

**ASSUMPTIONS:** (1) Plate is opaque, diffuse-gray and isothermal, (2) Furnace bottom behaves as a blackbody while sides are perfectly insulated, (3) Surroundings are large compared to the plate and behave as a blackbody.

**ANALYSIS:** (a) Recognize that the plate ( $A_1$ ), furnace bottom ( $A_2$ ) and furnace side walls ( $A_R$ ) form a three-surface enclosure with one surface being re-radiating. The net radiative heat transfer *leaving*  $A_1$  follows from Eq. 13.30 written as

$$q_1 = \frac{E_{b1} - E_{b2}}{\frac{1 - \epsilon_1}{\epsilon_1 A_1} + \frac{1}{A_1 F_{12} + (1/A_1 F_{1R} + 1/A_2 F_{2R})^{-1}} + \frac{1 - \epsilon_2}{\epsilon_2 A_2}} \quad (1)$$

From Fig. 13.4 with  $X/L = 0.2/0.2 = 1$  and  $Y/L = 0.2/0.2 = 1$ , it follows that  $F_{12} = 0.2$  and  $F_{1R} = 1 - F_{12} = 1 - 0.2 = 0.8$ . Hence, with  $F_{1R} = F_{2R}$  (by symmetry) and  $\epsilon_2 = 1$ .

$$q_1 = \frac{5.67 \times 10^{-8} \text{ W/m}^2 \cdot \text{K}^4 (400^4 - 1000^4) \text{ K}^4}{\frac{1 - 0.8}{0.8 \times 0.04 \text{ m}^2} + \frac{1}{0.04 \text{ m}^2 \times 0.20 + (2/0.04 \text{ m}^2 \times 0.8)^{-1}}} = -1153 \text{ W} <$$

It follows the net radiative exchange to the plate is,  $q_{\text{rad},f} = 1153$  W.

(b) Perform now an energy balance on the plate written as

$$\dot{E}_{\text{in}} - \dot{E}_{\text{out}} = \dot{E}_{\text{st}}$$

$$q_{\text{rad},f} - q_{\text{conv}} - q_{\text{rad},\text{sur}} = Mc_p \frac{dT_1}{dt}$$

$$q_{\text{rad},f} - hA_1(T_1 - T_\infty) - \epsilon_1 A_1 \sigma (T_1^4 - T_{\text{sur}}^4) = Mc_p \frac{dT_1}{dt}. \quad (2)$$

Substituting numerical values and rearranging to obtain  $dT/dt$ , find

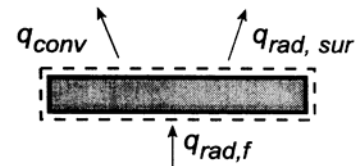

Continued ...

### PROBLEM 13.94 (Cont.)

$$\frac{dT_1}{dt} = \frac{1}{2 \text{ kg} \times 900 \text{ J/kg} \cdot \text{K}} \left[ +1153 \text{ W} - 25 \text{ W/m}^2 \cdot \text{K} \times 0.04 \text{ m}^2 (400 - 300) \text{ K} - 0.8 \times 0.04 \text{ m}^2 \times 5.67 \times 10^{-8} \text{ W/m}^2 \cdot \text{K}^4 (400^4 - 300^4) \text{ K}^4 \right] <$$

$$\frac{dT_1}{dt} = 0.57 \text{ K/s.}$$

(c) With Eqs. (1) and (2) in the *IHT* workspace,  $dT_1/dt$  was computed and plotted as a function of  $T_1$ .

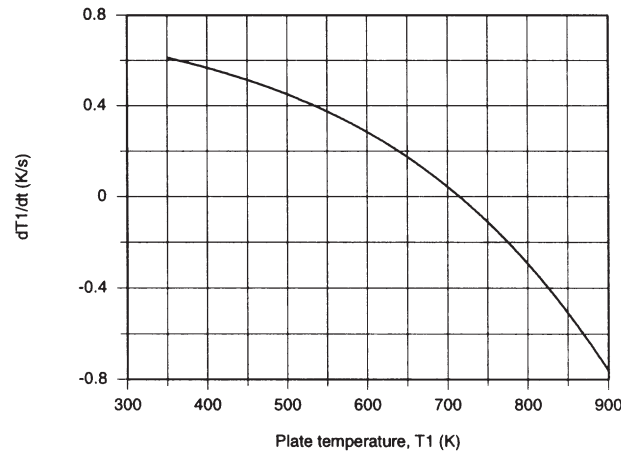

When  $T_1 = 400 \text{ K}$ , the condition of part (b), we found  $dT_1/dt = 0.57 \text{ K/s}$  which indicates the plate temperature is increasing with time. For  $T_1 = 900 \text{ K}$ ,  $dT_1/dt$  is a negative value indicating the plate temperature will decrease with time. The steady-state condition corresponds to  $dT_1/dt = 0$  for which

$$T_{1,ss} = 715 \text{ K} <$$

**COMMENTS:** Using the *IHT Radiation Tools – Radiation Exchange Analysis, Three Surface Enclosure with Re-radiating Surface and View Factors, Aligned Parallel Rectangle* – the above analysis can be performed. A copy of the workspace follows:

// Energy Balance on the Plate, Equation 2:

$$M \cdot c_p \cdot dTdt = -q_1 - h \cdot A_1 \cdot (T_1 - T_{inf}) - \epsilon_{ps1} \cdot A_1 \cdot \sigma \cdot (T_1^4 - T_{sur}^4)$$

/\* Radiation Tool – Radiation Exchange Analysis,

Three-Surface Enclosure with Reradiating Surface: \*/

/\* For the three-surface enclosure A1, A2 and the reradiating surface AR, the net rate of radiation transfer from the surface A1 to surface A2 is \*/

$$q_1 = (E_{b1} - E_{b2}) / \left( \frac{1 - \epsilon_{ps1}}{\epsilon_{ps1} \cdot A_1} + 1 / (A_1 \cdot F_{12} + 1 / (1 / (A_1 \cdot F_{1R}) + 1 / (A_2 \cdot F_{2R}))) \right) + (1 - \epsilon_{ps2}) / (\epsilon_{ps2} \cdot A_2) // \text{ Eq 13.30}$$

/\* The net rate of radiation transfer from surface A2 to surface A1 is \*/

$$q_2 = -q_1$$

/\* From a radiation energy balance on AR, \*/

$$(J_R - J_1) / (1 / (A_R \cdot F_{R1})) + (J_R - J_2) / (1 / (A_R \cdot F_{R2})) = 0 // \text{ Eq 13.31}$$

/\* where the radiosities J1 and J2 are determined from the radiation rate equations expressed in terms of the surface resistances, Eq 13.22 \*/

$$q_1 = (E_{b1} - J_1) / \left( \frac{1 - \epsilon_{ps1}}{\epsilon_{ps1} \cdot A_1} \right)$$

$$q_2 = (E_{b2} - J_2) / \left( \frac{1 - \epsilon_{ps2}}{\epsilon_{ps2} \cdot A_2} \right)$$

// The blackbody emissive powers for A1 and A2 are

$$E_{b1} = \sigma \cdot T_1^4$$

$$E_{b2} = \sigma \cdot T_2^4$$

// For the reradiating surface,

$$J_R = E_{bR}$$

Continued ...

## PROBLEM 13.94 (Cont.)

$E_bR = \sigma \cdot TR^4$   
 $\sigma = 5.67E-8$  // Stefan-Boltzmann constant,  $W/m^2 \cdot K^4$

### // Radiation Tool – View Factor:

/\* The view factor,  $F_{12}$ , for aligned parallel rectangles, is \*/

$F_{12} = F_{ij\_APR}(Xbar, Ybar)$

// where

$Xbar = X/L$

$Ybar = Y/L$

// See Table 13.2 for schematic of this three-dimensional geometry.

### // View Factors Relations:

$F_{1R} = 1 - F_{12}$

$FR_1 = F_{1R} \cdot A_1 / AR$

$FR_2 = FR_1$

$A_1 = X \cdot Y$

$A_2 = X \cdot Y$

$AR = 2 \cdot (X \cdot Z + Y \cdot Z)$

$Z = L$

$F_{2R} = F_{1R}$

### // Assigned Variables:

$T_1 = 400$  // Plate temperature, K  
 $\epsilon_{s1} = 0.8$  // Plate emissivity  
 $T_2 = 1000$  // Bottom temperature, K  
 $\epsilon_{s2} = 0.9999$  // Bottom surface emissivity  
 $X = 0.2$  // Plate dimension, m  
 $Y = 0.2$  // Plate dimension, m  
 $L = 0.2$  // Plate separation distance, m  
 $M = 2$  // Mass, kg  
 $c_p = 900$  // Specific heat, J/kg.K,  
 $h = 25$  // Convection coefficient,  $W/m^2 \cdot K$   
 $T_{inf} = 300$  // Ambient air temperature, K  
 $T_{sur} = 300$  // Surroundings temperature, K

### PROBLEM 13.95

**KNOWN:** Tool for processing silicon wafer within a vacuum chamber with cooled walls. Thin wafer is radiatively coupled on its back side to a chuck which is electrically heated. The top side is irradiated by an ion beam flux and experiences convection with the process gas and radioactive exchange with the ion-beam *grid* control surface and the chamber walls.

**FIND:** (a) Show control surfaces and all relevant processes on a schematic of the wafer, and (b) Perform an energy balance on the wafer and determine the chuck temperature  $T_c$  required to maintain the prescribed conditions.

**SCHEMATIC:**

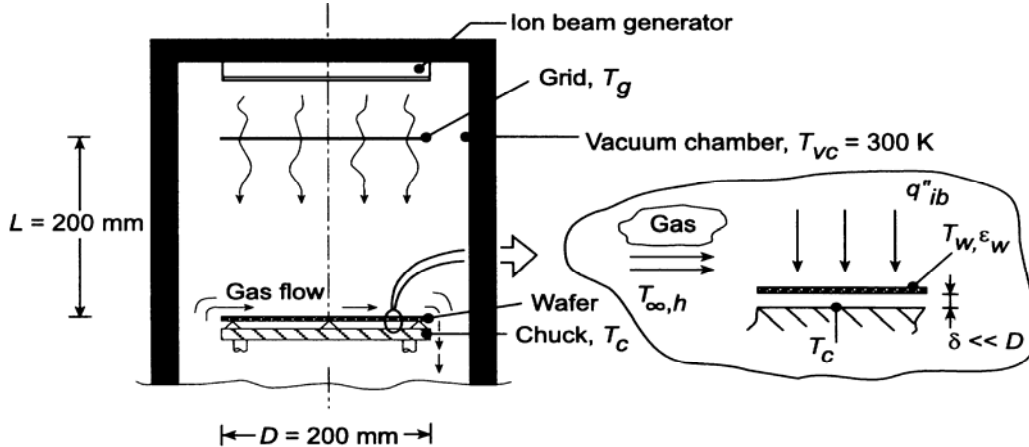

**ASSUMPTIONS:** (1) Steady-state conditions, (2) Wafer is diffuse, gray, (3) Separation distance between the wafer and chuck is much smaller than the wafer and chuck diameters, (4) Negligible convection in the gap between the wafer and chuck; convection occurs on the wafer top surface with the process gas, (5) Surfaces forming the three-surface enclosure – wafer ( $\epsilon_w = 0.8$ ), grid ( $\epsilon_g = 1$ ), and chamber walls ( $\epsilon_c = 1$ ) have uniform radiosity and are diffuse, gray, and (6) the chuck surface is black.

**ANALYSIS:** (a) The wafer is shown schematically above in relation to the key components of the tool: the ion beam generator, the grid which is used to control the ion beam flux,  $q''_{ib}$ , the chuck which aids in controlling the wafer temperature and the process gas flowing over the wafer top surface. The schematic below shows the control surfaces on the top and back surfaces of the wafer along with the relevant thermal processes:  $q_{cv}$ , convection between the wafer and process gas;  $q_a$ , applied heat source due to absorption of the ion beam flux,  $q''_{ib}$ ;  $q_{1,top}$ , net radiation leaving the top surface of the wafer (1) which is part of the three-surface enclosure – grid (2) and chamber walls (3), and;  $q_{1,bac}$ , net radiation leaving the backside of the wafer (w) which is part of a two-surface enclosure formed with the chuck (c).

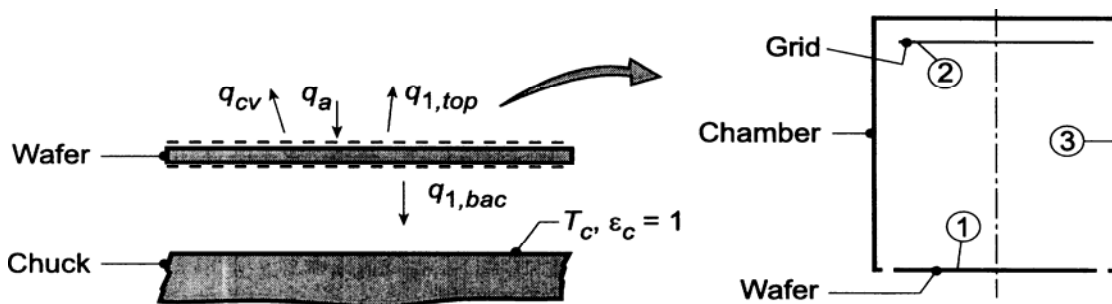

Continued ...

### PROBLEM 13.95 (Cont.)

(b) Referring to the schematic and the identified thermal processes, the energy balance on the wafer has the form,

$$\begin{aligned}\dot{E}_{\text{in}} - \dot{E}_{\text{out}} &= 0 \\ -q_{\text{cv}} + q_{\text{a}} - q_{1,\text{bac}} - q_{1,\text{top}} &= 0\end{aligned}\quad (1)$$

where each of the processes are evaluated as follows:

*Convection with the process gas:* with  $A_{\text{w}} = \pi D^2 / 4 = \pi (0.200\text{m})^2 / 4 = 0.03142\text{m}^2$ ,

$$q_{\text{cv}} = hA_{\text{w}} (T_{\text{w}} - T_{\text{g}}) = 10\text{ W/m}^2 \times 0.03142\text{m}^2 \times (700 - 500)\text{K} = 62.84\text{ W} \quad (2)$$

*Applied heat source – ion beam:*

$$q_{\text{a}} = q_{\text{ib}}'' A_{\text{w}} = 600\text{ W/m}^2 \times 0.03142\text{m}^2 = 18.85\text{ W} \quad (3)$$

*Net radiation heat rate, back side; enclosure (w,c):* for the two-surface enclosure comprised of the back side of the wafer (w) and the chuck, (c), Eq. 13.24, yields

$$\begin{aligned}q_{1,\text{bac}} &= \frac{\sigma (T_{\text{w}}^4 - T_{\text{c}}^4) A_{\text{w}}}{1/\varepsilon_{\text{w}}} \\ q_{1,\text{bac}} &= \frac{0.03142\text{m}^2 \times \sigma (700^4 - T_{\text{c}}^4)\text{K}^4}{1/0.6} = 1.069 \times 10^{-9} (700^4 - T_{\text{c}}^4)\end{aligned}\quad (4)$$

*Net radiation heat rate, top surface; enclosure (1, 2, 3):* from the surface energy balance on  $A_1$ , Eq. 13.19.

$$q_{1,\text{top}} = \frac{E_{\text{b1}} - J_1}{(1 - \varepsilon_1) / \varepsilon_1 A_1} \quad (5)$$

where  $\varepsilon_1 = \varepsilon_{\text{w}}$ ,  $A_1 = A_{\text{w}}$ ,  $E_{\text{b1}} = \sigma T_1^4$  and the radiosity can be evaluated by an enclosure analysis following the methodology of Section 13.3.2. From the energy balance, Eq. 13.21,

$$\frac{E_{\text{b1}} - J_1}{(1 - \varepsilon_1) / \varepsilon_1 A_1} = \frac{J_1 - J_2}{1/A_1 F_{12}} + \frac{J_1 - J_3}{1/A_1 F_{13}} \quad (6)$$

where  $J_2 = E_{\text{b2}} = \sigma T_{\text{g}}^4$  and  $J_3 = E_{\text{b3}} = \sigma T_{\text{vc}}^4$  since both surfaces are black ( $\varepsilon_{\text{g}} = \varepsilon_{\text{vc}} = 1$ ). The view factor  $F_{12}$  can be computed from the relation for coaxial parallel disks, Table 13.5.

$$\begin{aligned}F_{12} &= 0.5 \left\{ S - \left[ S^2 - 4(r_2/r_1)^2 \right]^{1/2} \right\} = 0.5 \left\{ 6.0 - \left[ 6.0^2 - 4(1)^2 \right]^{1/2} \right\} = 0.1716 \\ S &= 1 + \frac{1 + R_2^2}{R_1^2} = 1 + \frac{1 + 0.5^2}{0.5^2} = 6.00\end{aligned}$$

Continued ...



**PROBLEM 13.95 (Cont.)**

$$R_1 = r_1 / L = 100 / 200 = 0.5$$

$$R_4 = r_4 / L = 0.5$$

The view factor  $F_{13}$  follows from the summation rule applied to  $A_1$ ,

$$F_{13} = 1 - F_{12} = 1 - 0.1716 = 0.8284$$

Substituting numerical values into Eq. (6), with  $T_1 = T_w = 700$  K,  $T_2 = T_g = 500$  K, and  $T_3 = T_{vc} = 300$  K, find  $J_1$ ,

$$\frac{\sigma T_1^4 - J_1}{(1 - \varepsilon_1) / \varepsilon_1 A_1} = \frac{J_1 - \sigma T_g^4}{1 / F_{12}} + \frac{J_1 - \sigma T_{vc}^4}{1 / F_{13}} \quad (7)$$

$$J_1 = 8564 \text{ W/m}^2$$

Using Eq. (5), find  $q_{1,\text{top}}$  with  $E_{b2} = \sigma T_w^4 = 13,614 \text{ W/m}^2$  and  $A_1 = A_w$ ,

$$q_{1,\text{top}} = \frac{(13,614 - 8564) \text{ W/m}^2}{(1 - 0.6) / (0.6 \times 0.03142 \text{ m}^2)} = 238 \text{ W}$$

Evaluating  $T_c$  from the energy balance on the wafer, Eq. (1), and substituting appropriate expressions for each of the processes, find

$$-62.84 \text{ W/m}^2 + 18.85 \text{ W} - 1.069 \times 10^{-9} (700^4 - T_c^4) - 238 \text{ W} = 0$$

$$T_c = 842.5 \text{ K}$$

&lt;

From Eq. (4), with  $T_c = 815$  K, the electrical power required to maintain the chuck is

$$P_c = -q_{1,\text{bac}} = 1.069 \times 10^{-9} (842.5^4 - 700^4) = 282 \text{ W}$$

**COMMENTS:** Recognize that the method of analysis is centered about an energy balance on the wafer. Identifying the processes and representing them on the energy balance schematic, as described in Chapter 1, is a vital step in developing the strategy for a solution.

## PROBLEM 13.96

**KNOWN:** Dimensions and temperatures of rotating and stationary disks, air gap spacing between disks, rotational speed. Ambient and surroundings temperatures. Correlation for the local Nusselt number. Initial painted surfaces and emissivity of exposed base metal on the rotating disk.

**FIND:** Total power dissipated from the top surface of the rotating disk for painted and unpainted conditions.

**SCHEMATIC:**

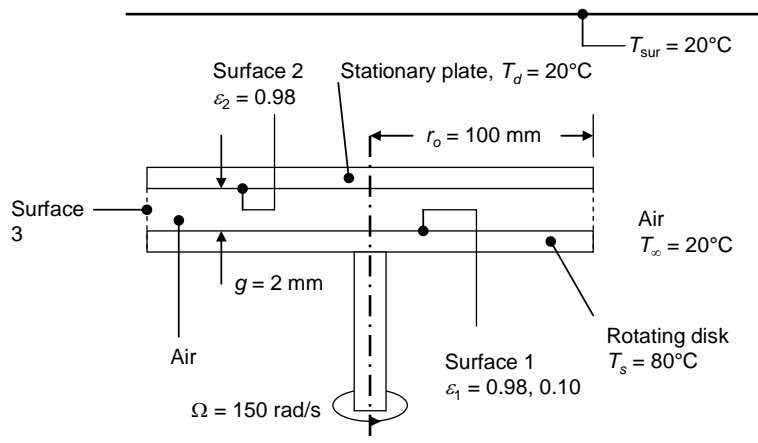

**ASSUMPTIONS:** (1) Steady-state conditions, (2) Constant properties, (3) Diffuse-gray surfaces with uniform radiosity and irradiation distributions, (4) Large surroundings.

**PROPERTIES:** Table A.4, air ( $T = (80^\circ\text{C} + 20^\circ\text{C})/2 = 50^\circ\text{C} \approx 323\text{K}$ ):  $\nu = 18.20 \times 10^{-6} \text{ m}^2/\text{s}$ ,  $k = 0.0280 \text{ W/m}\cdot\text{K}$ . Table A.11, Parsons black paint,  $\varepsilon = 0.98$ .

**ANALYSIS:** From Problem 6.17,  $Nu_r = \frac{h(r)r_o}{k} = 70(1 + e^{-140G})Re_{r_o}^{-0.456}Re_r^{0.478}$ .

Since  $Re_r = \Omega r^2 / \nu$ , the local heat transfer coefficient is

$$h(r) = k \left[ 70(1 + e^{-140G}) \left( \frac{\Omega r_o^2}{\nu} \right)^{-0.456} \left( \frac{\Omega}{\nu} \right)^{0.478} \right] r^{-0.044}$$

The average heat transfer coefficient may be evaluated from

$$\bar{h} = \frac{1}{A_s} \int_{A_s} h(r) dA_s = \frac{2\pi k}{\pi r_o^2} \left[ 70(1 + e^{-140G}) \left( \frac{\Omega r_o^2}{\nu} \right)^{-0.456} \left( \frac{\Omega}{\nu} \right)^{0.478} \right] \int_0^{r_o} r \times r^{-0.044} dr$$

or

$$\bar{h} = \frac{1.022k}{r_o^2} \left[ 70(1 + e^{-140G}) \left( \frac{\Omega r_o^2}{\nu} \right)^{-0.456} \left( \frac{\Omega}{\nu} \right)^{0.478} \right] r_o^{1.956}$$

Continued...

### PROBLEM 13.96 (Cont.)

Substituting values,

$$\bar{h} = \frac{1.022 \times 0.0280 \text{ W/m}^2 \cdot \text{K}}{(0.100 \text{ m})^2} \times \left[ 70 \left( 1 + e^{-140 \times 0.02} \right) \left( \frac{150 \text{ rad/s} \times (0.100 \text{ m})^2}{18.20 \times 10^{-6} \text{ m}^2/\text{s}} \right)^{-0.456} \left( \frac{150 \text{ rad/s}}{18.20 \times 10^{-6} \text{ m}^2/\text{s}} \right)^{0.478} \right] (0.100 \text{ m})^{1.956}$$

or

$$\bar{h} = 27.26 \text{ W/m}^2 \cdot \text{K}$$

The convective heat flux from the top surface of the disk is

$$q''_{\text{conv}} = \bar{h}(T_s - T_d) = 27.26 \text{ W/m}^2 \cdot \text{K} \times (80 - 20)^\circ\text{C} = 1636 \text{ W/m}^2$$

and the convective heat rate is

$$q_{\text{conv}} = q'' \pi r_o^2 = 1636 \text{ W/m}^2 \times \pi \times (0.10 \text{ m})^2 = 51.38 \text{ W}$$

The radiation heat transfer from the rotating disk may be determined by use of Eq. 13.21.

Surfaces 1 and 2:

$$\frac{\sigma T_1^4 - J_1}{(1 - \varepsilon_1)/\varepsilon_1 A_1} = \frac{J_1 - J_2}{1/A_1 F_{12}} + \frac{J_1 - J_3}{1/A_1 F_{13}} \quad ; \quad \frac{\sigma T_2^4 - J_2}{(1 - \varepsilon_2)/\varepsilon_2 A_2} = \frac{J_2 - J_1}{1/A_1 F_{12}} + \frac{J_2 - J_3}{1/A_2 F_{23}} \quad (1,2)$$

while for black Surface 3,  $J_3 = \sigma T_3^4 = 5.67 \times 10^{-8} \text{ W/m}^2 \cdot \text{K}^4 \times (20 + 273 \text{ K})^4 = 417.8 \text{ W/m}^2$ . Using the result for coaxial parallel disks in Table 13.2,  $R_1 = R_2 = r_o/g = 100 \text{ mm}/2 \text{ mm} = 50$ ,  $S = 1 + 2501/2500 = 2.0004$ , and

$$F_{12} = \frac{1}{2} \left\{ 2.0004 - \left[ 2.0004^2 - 4 \right]^{1/2} \right\} = 0.9802 \quad ; \quad F_{13} = 1 - F_{12} = 1 - 0.9802 = 0.0198$$

while  $A_1 = A_2 = \pi r_o^2 = \pi \times (0.100 \text{ m})^2 = 0.0314 \text{ m}^2$ . Substituting values of the view factors, areas, emissivities and  $J_3$  into Equations (1) and (2), and solving simultaneously yields

$$\varepsilon_1 = 0.98: J_1 = 871.3 \text{ W/m}^2, J_2 = 426.8 \text{ W/m}^2 \quad ; \quad \varepsilon_1 = 0.10: J_1 = 464.9 \text{ W/m}^2, J_2 = 417.9 \text{ W/m}^2$$

From Eq. 13.19,

$$q_{1,\text{rad},0.98} = \frac{\sigma T_1^4 - J_1}{(1 - \varepsilon_1)/\varepsilon_1 A_1} = \frac{5.67 \times 10^{-8} \text{ W/m}^2 \cdot \text{K}^4 \times (80 + 273 \text{ K})^4 - 871.3 \text{ W/m}^2}{(1 - 0.98)/(0.98 \times 0.0314 \text{ m}^2)} = 13.97 \text{ W}$$

Continued...

### PROBLEM 13.96 (Cont.)

and

$$q_{1,\text{rad},0.10} = \frac{\sigma T_1^4 - J_1}{(1 - \varepsilon_1)/\varepsilon_1 A_1} = \frac{5.67 \times 10^{-8} \text{ W/m}^2 \cdot \text{K}^4 \times (80 + 273 \text{ K})^4 - 464.9 \text{ W/m}^2}{(1 - 0.10)/(0.10 \times 0.0314 \text{ m}^2)} = 1.45 \text{ W}$$

The total power dissipated from the top surface of the rotating disk is:

$$\varepsilon_1 = 0.98: q = q_{\text{conv}} + q_{1,\text{rad},0.98} = 51.38 \text{ W} + 13.97 \text{ W} = 65.35 \text{ W} \quad <$$

$$\varepsilon_1 = 0.10: q = q_{\text{conv}} + q_{1,\text{rad},0.10} = 51.38 \text{ W} + 1.45 \text{ W} = 52.83 \text{ W} \quad <$$

**COMMENTS:** (1) The influence of the black surroundings is small since the view factors from the disks to the surroundings are small, the stationary disk temperature is the same as that of the surroundings, and the emissivity of the stationary disk is close to unity. Use of the result for infinite parallel surfaces (Equation 13.24) yields heat rates of 13.95 and 1.45 W for the high and low emissivity cases, respectively. (2) See Pelle and Harmand, "Heat Transfer Measurements in an Opened Rotor-Stator System Air-Gap," *Experimental Thermal and Fluid Science*, 'Vol. 31, pp. 165 – 180, 2007, for additional discussion.

## PROBLEM 13.97

**KNOWN:** Ice rink with prescribed ice, rink air, wall, ceiling and outdoor air conditions.

**FIND:** (a) Temperature of the ceiling,  $T_c$ , having an emissivity of 0.05 (highly reflective panels) or 0.94 (painted panels); determine whether condensation will occur for either or both ceiling panel types if the relative humidity of the rink air is 70%, and (b) Calculate and plot the ceiling temperature as a function of ceiling insulation thickness for  $0.1 \leq t \leq 1$  m, identify conditions for which condensation will occur on the ceiling.

**SCHEMATIC:**

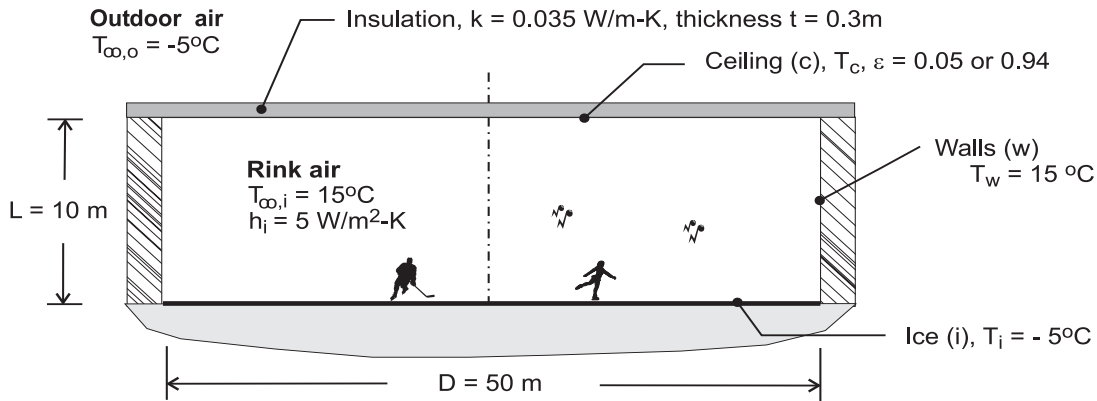

**ASSUMPTIONS:** (1) Rink comprised of the ice, walls and ceiling approximates a three-surface, diffuse-gray enclosure, (2) Surfaces have uniform radiosities, (3) Ice surface and walls are black, (4) Panels are diffuse-gray, and (5) Thermal resistance for convection on the outdoor side of the ceiling is negligible compared to the conduction thermal resistance of the ceiling insulation.

**PROPERTIES:** *Psychrometric chart* (Atmospheric pressure; dry bulb temperature,  $T_{db} = T_{\infty,i} = 15^\circ\text{C}$ ; relative humidity,  $\text{RH} = 70\%$ ): Dew point temperature,  $T_{dp} = 9.4^\circ\text{C}$ .

**ANALYSIS:** The energy balance on the ceiling illustrated in the schematic below has the form

$$\begin{aligned} \dot{E}_{\text{in}} - \dot{E}_{\text{out}} &= 0 \\ -q_o - q_{\text{conv},c} - q_{\text{rad},c} &= 0 \end{aligned} \quad (1)$$

where the rate equations for each process are

$$q_o = (T_c - T_{\infty,o}) / R_{\text{cond}} \quad R_{\text{cond}} = t / kA_c \quad (2,3)$$

$$q_{\text{conv},c} = h A_c (T_c - T_{\infty,i}) \quad (4)$$

$$q_{\text{rad},c} = \varepsilon E_b (T_c) A_c - \alpha A_w F_{wc} E_b (T_w) - \alpha A_i F_{ic} E_b (T_i) \quad (5)$$

The blackbody emissive powers are  $E_b = \sigma T^4$  where  $\sigma = 5.67 \times 10^{-8} \text{ W/m}^2 \cdot \text{K}^4$ . Since the ceiling panels are diffuse-gray,  $\alpha = \varepsilon$ . The view factors required of Eq. (5): determine  $F_{ic}$  (ice to ceiling) from Table 13.2 (Fig. 13.5) for parallel, coaxial disks

$$F_{ic} = 0.672$$

and  $F_{wc}$  (wall to ceiling) from the summation rule on the ice (i) and the reciprocity rule,

$$F_{ic} + F_{iw} = 1 \quad F_{iw} = F_{cw} \text{ (symmetry)}$$

$$F_{cw} = 1 - F_{ic}$$

$$F_{wc} = (A_c / A_w) F_{cw} = (A_c / A_w) (1 - F_{ic}) = 0.410$$

Continued ...

### PROBLEM 13.97 (Cont.)

where  $A_c = \pi D^2/4$  and  $A_w = \pi DL$ .

Using the foregoing energy balance, Eq. (1), and the rate equations, Eqs. (2-5), the ceiling temperature is calculated using radiative properties for the two panel types,

Ceiling panel	$\varepsilon$	$T_c$ (°C)		
Reflective	0.05	14.0		
Paint	0.94	8.6	$T_c < T_{dp}$	<

Condensation will occur on the painted panel since  $T_c < T_{dp}$ .

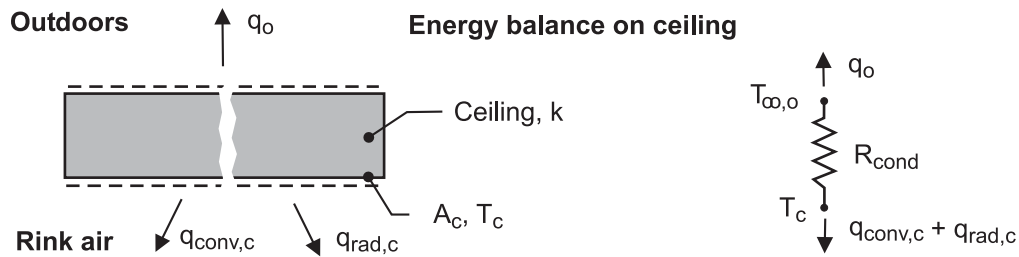

(b) The equations required of the analysis above were solved using *IHT*. The analysis is extended to calculate the ceiling temperatures for a range of insulation thickness and the results plotted below.

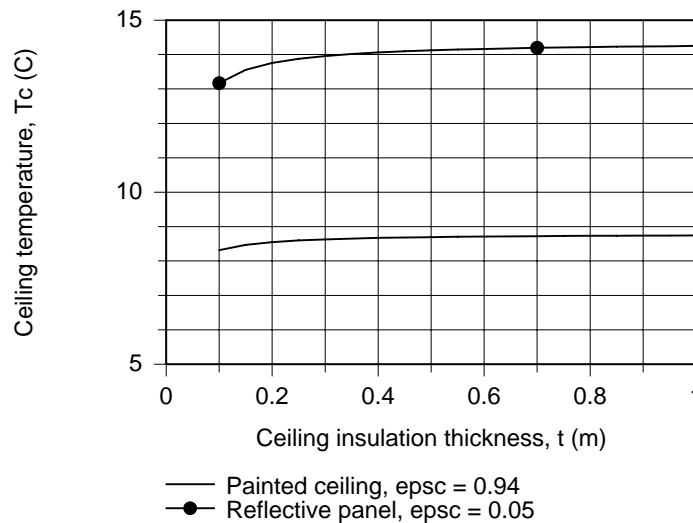

For the reflective panel ( $\varepsilon = 0.05$ ), the ceiling surface temperature is considerably above the dew point. Therefore, condensation will not occur for the range of insulation thickness shown. For the painted panel ( $\varepsilon = 0.94$ ), the ceiling surface temperature is always below the dew point. We expect condensation to occur for the range of insulation thickness shown.

**COMMENTS:** From the analysis, recognize that the radiative exchange between the ice and the ceiling is the dominant process for influencing the ceiling temperature. With the reflective panel, the rate is reduced nearly 20 times that with the painted panel. With the painted panel ceiling, for most of the conditions likely to exist in the rink, condensation will occur.

### PROBLEM 13.98

**KNOWN:** Diameter, temperature and emissivity of boiler tube. Thermal conductivity and emissivity of ash deposit. Convection coefficient and temperature of gas flow over the tube. Temperature of surroundings.

**FIND:** (a) Rate of heat transfer to tube without ash deposit, (b) Rate of heat transfer with an ash deposit of diameter  $D_d = 0.06$  m, (c) Effect of deposit diameter and convection coefficient on heat rate and contributions due to convection and radiation.

**SCHEMATIC:**

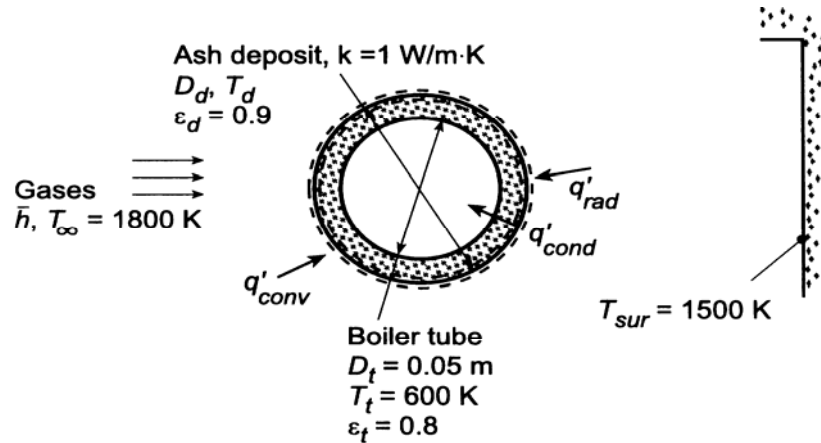

**ASSUMPTIONS:** (1) Diffuse/gray surface behavior, (2) Surroundings form a large enclosure about the tube and may be approximated as a blackbody, (3) One-dimensional conduction in ash, (4) Steady-state.

**ANALYSIS:** (a) Without an ash deposit, the heat rate per unit tube length may be calculated directly.

$$q' = \bar{h}\pi D_t (T_\infty - T_t) + \varepsilon_t \sigma \pi D_t (T_{sur}^4 - T_t^4)$$

$$q' = 100 \text{ W/m}^2 \cdot \text{K} (\pi) 0.05 \text{ m} (1800 - 600) \text{ K} + 0.8 \times 5.67 \times 10^{-8} \text{ W/m}^2 \cdot \text{K}^4 (\pi) (0.05 \text{ m}) (1500^4 - 600^4) \text{ K}^4$$

$$q' = (18,850 + 35,150) \text{ W/m} = 54,000 \text{ W/m} \quad <$$

(b) Performing an energy balance for a control surface about the outer surface of the ash deposit,

$$q'_{conv} + q'_{rad} = q'_{cond}, \text{ or}$$

$$\bar{h}\pi D_d (T_\infty - T_d) + \varepsilon_d \sigma \pi D_d (T_{sur}^4 - T_d^4) = \frac{2\pi k (T_d - T_t)}{\ln(D_d/D_t)}$$

Hence, canceling  $\pi$  and considering an ash deposit for which  $D_d = 0.06$  m,

$$\begin{aligned} 100 \text{ W/m}^2 \cdot \text{K} (0.06 \text{ m}) (1800 - T_d) \text{ K} + 0.9 \times 5.67 \times 10^{-8} \text{ W/m}^2 \cdot \text{K}^4 (0.06 \text{ m}) (1500^4 - T_d^4) \text{ K}^4 \\ = \frac{2(1 \text{ W/m} \cdot \text{K})(T_d - 600) \text{ K}}{\ln(0.06/0.05)} \end{aligned}$$

A trial-and-error, or *IHT* solution yields  $T_d \approx 1346$  K, from which it follows that

$$q' = \bar{h}\pi D_d (T_\infty - T_d) + \varepsilon_d \sigma \pi D_d (T_{sur}^4 - T_d^4)$$

$$q' = 100 \text{ W/m}^2 \cdot \text{K} (\pi) 0.06 \text{ m} (1800 - 1346) \text{ K} + 0.9 \times 5.67 \times 10^{-8} \text{ W/m}^2 \cdot \text{K}^4 (\pi) 0.06 \text{ m} (1500^4 - 1346^4) \text{ K}^4$$

Continued ...

### PROBLEM 13.98 (Cont.)

$$q' = (8560 + 17,140) \text{ W/m} = 25,700 \text{ W/m}$$

<

(c) The foregoing energy balance was entered into the *IHT* workspace and parametric calculations were performed to explore the effects of  $\bar{h}$  and  $D_d$  on the heat rates.

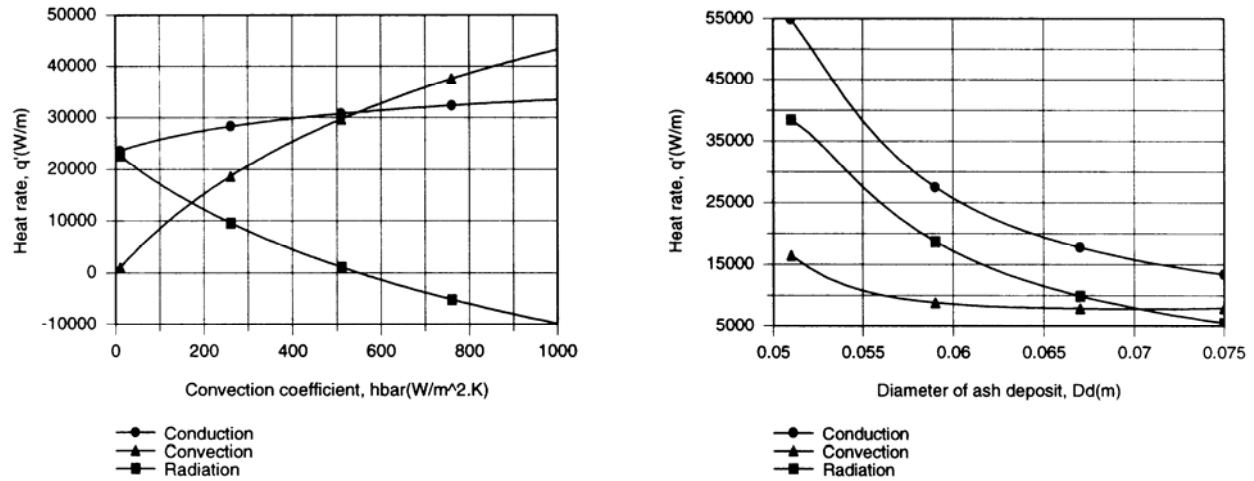

For  $D_d = 0.06$  m and  $10 \leq \bar{h} \leq 1000$  W/m<sup>2</sup>·K, the heat rate to the tube,  $q'_{\text{cond}}$ , as well as the contribution due to convection,  $q'_{\text{conv}}$ , increase with increasing  $\bar{h}$ . However, because the outer surface temperature  $T_d$  also increases with  $\bar{h}$ , the contribution due to radiation decreases and becomes negative (heat transfer from the surface) when  $T_d$  exceeds 1500 K at  $\bar{h} = 540$  W/m<sup>2</sup>·K. Both the convection and radiation heat rates, and hence the conduction heat rate, increase with decreasing  $D_d$ , as  $T_d$  decreases and approaches  $T_t = 600$  K. However, even for  $D_d = 0.051$  m (a deposit thickness of 0.5 mm),  $T_d = 773$  K and the ash provides a significant resistance to heat transfer.

**COMMENTS:** Boiler operation in an energy efficient manner dictates that ash deposits be removed periodically.



## PROBLEM 13.99

**KNOWN:** Two large parallel plates, separation distance and temperature of top plate. Gap between plates is filled with atmospheric pressure air, and heat flux from the bottom plate.

**FIND:** (a) Temperature of the bottom plate and the ratio of the convective to radiative heat fluxes for  $\varepsilon_1 = \varepsilon_2 = 0.5$ , (b) Temperature of the bottom plate and the ratio of the convective to radiative heat fluxes for  $\varepsilon_1 = \varepsilon_2 = 0.25$  and  $0.75$ .

**SCHEMATIC:**

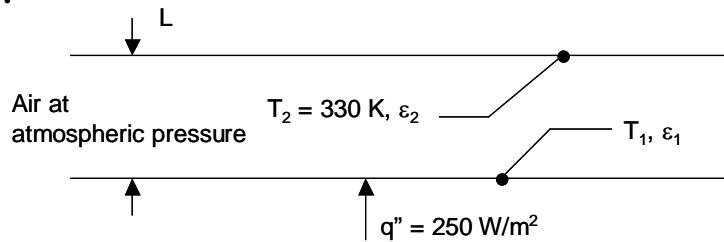

**ASSUMPTIONS:** (1) One-dimensional heat transfer, (2) Steady-state conditions, (3) Constant properties, (4) Diffuse, gray surfaces, (5) Ideal gas behavior.

**PROPERTIES:** Table A.4, air ( $\bar{T} = 350 \text{ K}$ ):  $k = 0.030 \text{ W/m}\cdot\text{K}$ ,  $\alpha = 2.99 \times 10^{-5} \text{ m}^2/\text{s}$ ,  $\nu = 2.092 \times 10^{-5} \text{ m}^2/\text{s}$ ,  $\text{Pr} = 0.70$ .

**ANALYSIS:** (a) The heat flux is composed of radiation and convection components,

$$q'' = q''_{\text{rad}} + q''_{\text{conv}} \quad (1)$$

where

$$q''_{\text{rad}} = \frac{\sigma(T_1^4 - T_2^4)}{\frac{1}{\varepsilon_1} + \frac{1}{\varepsilon_2} - 1} \quad (2)$$

and

$$q''_{\text{conv}} = \bar{h}(T_1 - T_2) \quad (3)$$

We evaluate  $\bar{h}$  by using the Globe and Dropkin correlation of Chapter 9,

$$\bar{h} = \frac{k}{L} \left[ 0.069 \text{Ra}_L^{1/3} \text{Pr}^{0.074} \right] \quad (4)$$

where

Continued...

**PROBLEM 13.99 (Cont.)**

$$Ra_L = \frac{g\beta(T_1 - T_2)L^3}{\nu\alpha} \quad (5)$$

Combining Eqs. (1) through (5) yields

$$q'' = \frac{\sigma(T_1^4 - T_2^4)}{\frac{1}{\epsilon_1} + \frac{1}{\epsilon_2} - 1} + \left[ 0.069k \left( \frac{g\beta(T_1 - T_2)}{\nu\alpha} \right)^{1/3} Pr^{0.074} \right] (T_1 - T_2) \quad (6)$$

or

$$250 \text{ W/m}^2 = \frac{5.67 \times 10^{-8} \frac{\text{W}}{\text{m}^2 \cdot \text{K}^4} \times [T_1^4 - (330\text{K})^4]}{\frac{1}{0.5} + \frac{1}{0.5} - 1} + \left[ 0.069 \times 0.030 \frac{\text{W}}{\text{m} \cdot \text{K}} \left( \frac{9.81 \frac{\text{m}}{\text{s}^2} \times \frac{1}{350\text{K}} \times (T_1 - 330)\text{K}}{2.092 \times 10^{-5} \frac{\text{m}^2}{\text{s}} \times 2.99 \times 10^{-5} \frac{\text{m}^2}{\text{s}}} \right)^{1/3} \times 0.70^{0.074} \right] \times (T_1 - 330)\text{K} \quad (7)$$

Equation (7) may be solved iteratively or with *IHT* to yield  $T_1 = 373 \text{ K}$ . <

In addition,

$$Ra_L = \frac{9.8 \frac{\text{m}}{\text{s}^2} \times \frac{1}{350\text{K}} \times (373 - 330)\text{K} \times (0.1\text{m})^3}{2.092 \times 10^{-5} \frac{\text{m}^2}{\text{s}} \times 2.99 \times 10^{-5} \frac{\text{m}^2}{\text{s}}} = 1.93 \times 10^6$$

and

$$h = \frac{0.030 \frac{\text{W}}{\text{m} \cdot \text{K}}}{0.10\text{m}} \left[ 0.069 \times (1.93 \times 10^6)^{1/3} \times 0.70^{0.074} \right] = 2.51 \frac{\text{W}}{\text{m}^2 \cdot \text{K}}$$

$$q''_{\text{conv}} = 2.52 \frac{\text{W}}{\text{m}^2 \cdot \text{K}} \times (373 - 300)\text{K} = 108 \frac{\text{W}}{\text{m}^2}$$

$$q''_{\text{rad}} = q'' - q''_{\text{conv}} = 250 \frac{\text{W}}{\text{m}^2} - 108 \frac{\text{W}}{\text{m}^2} = 142 \frac{\text{W}}{\text{m}^2}; \quad \frac{q''_{\text{conv}}}{q''_{\text{rad}}} = \frac{108}{142} = 0.76 \quad <$$

Continued...

### PROBLEM 13.99 (Cont.)

(b) Substituting  $\varepsilon_1 = \varepsilon_2 = 0.25$  into Eq. (6) yields

$$T_1 = 388.4 \text{ K}, Ra_L = 2.6 \times 10^6, \bar{h} = 2.78 \text{ W/m}^2\cdot\text{K}, q_{\text{conv}}'' = 162 \text{ W/m}^2, q_{\text{rad}}'' = 88 \text{ W/m}^2,$$
$$\frac{q_{\text{conv}}''}{q_{\text{rad}}''} = \frac{162}{88} = 1.84 \quad <$$

(c) Substituting  $\varepsilon_1 = \varepsilon_2 = 0.75$  into Eq. (6) yields

$$T_1 = 361.6 \text{ K}, Ra_L = 1.4 \times 10^6, \bar{h} = 2.26 \text{ W/m}^2\cdot\text{K}, q_{\text{conv}}'' = 72 \text{ W/m}^2, q_{\text{rad}}'' = 178 \text{ W/m}^2,$$
$$\frac{q_{\text{conv}}''}{q_{\text{rad}}''} = \frac{72}{178} = 0.40 \quad <$$

**COMMENT:** Note the increase in the temperature difference between the plates as the emissivity is reduced. Both the radiation and convection heat fluxes are highly sensitive to the plate emissivity.

### PROBLEM 13.100

**KNOWN:** Dimensions, emissivities and temperatures of heated and cooled surfaces at opposite ends of a cylindrical cavity. External conditions.

**FIND:** Required heater power and outside convection coefficient.

**SCHEMATIC:**

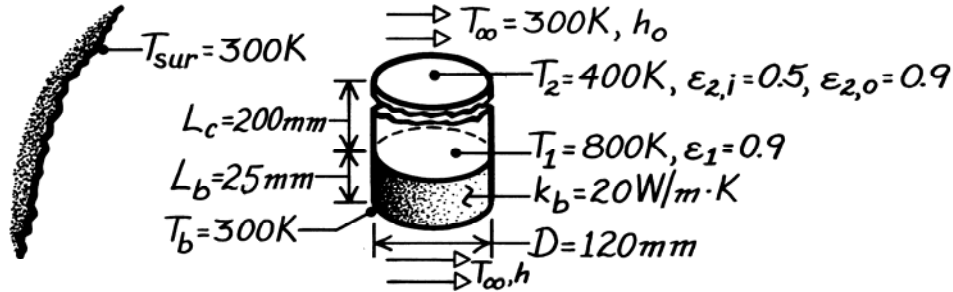

**ASSUMPTIONS:** (1) Steady-state conditions, (2) Opaque, diffuse-gray surfaces, (3) Negligible convection within cavity, (4) Isothermal disk and heater surfaces, (5) One-dimensional conduction in base, (6) Negligible contact resistance between heater and base, (7) Sidewall is reradiating.

**ANALYSIS:** The equivalent circuit is

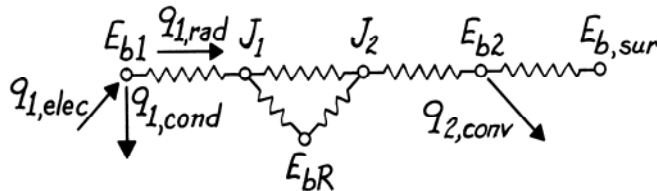

From an energy balance on the heater surface,  $q_{1,\text{elec}} = q_{1,\text{cond}} + q_{1,\text{rad}}$ ,

$$q_{1,\text{elec}} = k_b \left( \frac{\pi D^2}{4} \right) \frac{T_1 - T_b}{L_b} + \frac{\sigma (T_1^4 - T_2^4)}{\frac{1 - \epsilon_1}{\epsilon_1 A_1} + \frac{1}{A_1 F_{12} + [(1/A_1 F_{1R}) + (1/A_2 F_{2R})]^{-1}} + \frac{1 - \epsilon_{2,i}}{\epsilon_{2,i} A_2}}$$

where  $A_1 = A_2 = \pi D^2/4 = \pi(0.12 \text{ m})^2/4 = 0.0113 \text{ m}^2$  and from Fig. 13.5, with  $L_c/r_1 = 3.33$  and  $r_2/L_c = 0.3$  find  $F_{12} = F_{21} = 0.077$ ; hence,  $F_{1R} = F_{2R} = 0.923$ . The required heater power is

$$q_{1,\text{elec}} = 20 \text{ W/m} \cdot \text{K} \times 0.0113 \text{ m}^2 \frac{(800 - 300) \text{ K}}{0.025 \text{ m}} + \frac{0.0113 \text{ m}^2 \times 5.67 \times 10^{-8} \text{ W/m}^2 \cdot \text{K}^4 (800^4 - 400^4) \text{ K}^4}{\frac{1 - 0.9}{0.9} + \frac{1}{0.077 + [(1/0.923) + (1/0.923)]^{-1}} + \frac{1 - 0.5}{0.5}}$$

$$q_{1,\text{elec}} = 4521 \text{ W} + 82.9 \text{ W} = 4604 \text{ W} \quad <$$

An energy balance for the disk yields,  $q_{\text{rad},2} = q_{\text{rad},1} = h_o A_2 (T_2 - T_\infty) + \epsilon_{2,o} A_2 \sigma (T_2^4 - T_{\text{sur}}^4)$ ,

$$h_o = \frac{82.9 \text{ W} - 0.9 \times 0.0113 \text{ m}^2 \times 5.67 \times 10^{-8} \text{ W/m}^2 \cdot \text{K}^4 (400^4 - 300^4) \text{ K}^4}{0.0113 \text{ m}^2 \times 100 \text{ K}} = 64 \text{ W/m}^2 \cdot \text{K} \quad <$$

**COMMENTS:** Conduction through the ceramic base represents an enormous system loss. The base should be insulated to greatly reduce this loss and hence the electric power input.

## PROBLEM 13.101

**KNOWN:** Emissivity of glass sheets. Inside and outside temperatures and convection heat transfer coefficients. Type of gas within gap.

**FIND:** Heat flux through the window for case 1:  $\varepsilon_1 = \varepsilon_2 = 0.95$ , case 2:  $\varepsilon_1 = \varepsilon_2 = 0.05$ , and case 3:  $\varepsilon_1 = 0.05$ ,  $\varepsilon_2 = 0.95$ , with either air or argon between the glass sheets.

**SCHEMATIC:**

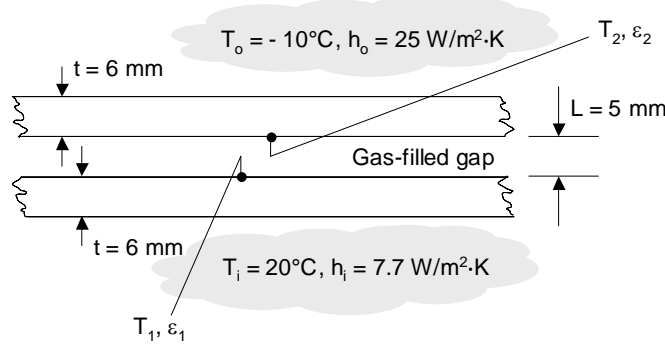

**ASSUMPTIONS:** (1) Diffuse-gray surfaces, (2) Infinite parallel glass surfaces, (3) Negligible radiation on exterior surfaces, (4) Negligible natural convection in gap.

**PROPERTIES:** Table A.4, Air (300 K):  $k = 0.0263$  W/m·K. Table A.3, Plate Glass (300 K):  $k = 1.4$  W/m·K.

**ANALYSIS:** The thermal resistance network is shown below.

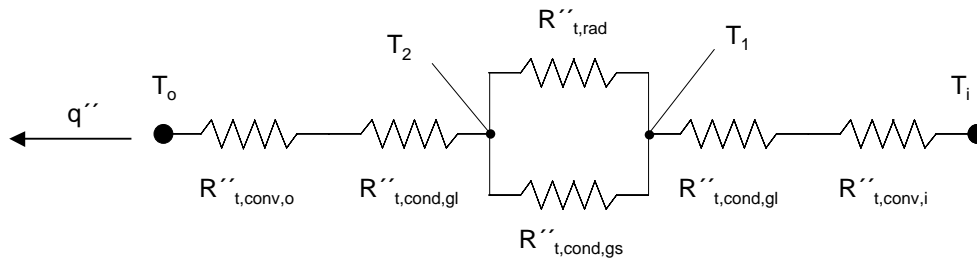

The thermal resistances are as follows.

$$\begin{aligned}
 R''_{t,conv,o} &= 1/h_o = 1/(25 \text{ W/m}^2 \cdot \text{K}) = 0.040 \text{ m}^2 \cdot \text{K/W} \\
 R''_{t,cond,gl} &= t/k_g = 0.006 \text{ m}/(1.4 \text{ W/m} \cdot \text{K}) = 0.0043 \text{ m}^2 \cdot \text{K/W} \\
 R''_{t,cond,gs} &= L/k_{gs} = 0.005 \text{ m}/(0.0263 \text{ W/m} \cdot \text{K}) = 0.190 \text{ m}^2 \cdot \text{K/W} \quad (\text{for air}) \\
 R''_{t,cond,gs} &= L/k_{gs} = 0.005 \text{ m}/(0.0177 \text{ W/m} \cdot \text{K}) = 0.282 \text{ m}^2 \cdot \text{K/W} \quad (\text{for argon}) \\
 R''_{t,conv,i} &= 1/h_i = 1/(7.7 \text{ W/m}^2 \cdot \text{K}) = 0.130 \text{ m}^2 \cdot \text{K/W} \\
 R''_{t,rad} &= \frac{1/\varepsilon_1 + 1/\varepsilon_2 - 1}{\sigma(T_1^2 + T_2^2)(T_1 + T_2)} \quad (1)
 \end{aligned}$$

Note that the radiation thermal resistance of Eq. 1 depends on the interior surface temperatures,  $T_1$  and  $T_2$ . To avoid a tedious iterative procedure, IHT is used to solve three coupled algebraic equations that may be derived by equating the heat flux from  $T_i$  to  $T_1$ , from  $T_1$  to  $T_2$ , and from  $T_2$  to  $T_o$ .

Continued...

**PROBLEM 13.101 (Cont.)**

$$\text{From } T_i \text{ to } T_1: \quad q'' = (T_i - T_1) / (R_{t,conv,i}'' + R_{t,cond,gl}'') \quad (2)$$

$$\text{From } T_1 \text{ to } T_2: \quad q'' = (T_1 - T_2) \left[ \frac{1}{R_{t,rad}''} + \frac{1}{R_{t,cond,gs}''} \right] \quad (3)$$

$$\text{From } T_2 \text{ to } T_o: \quad q'' = (T_2 - T_o) / (R_{t,cond,gl}'' + R_{t,conv,o}'') \quad (4)$$

Solving Eqs. (2) through (3) simultaneously, using the resistance values and expressions provided above, yields the following results.

Gas	$\varepsilon_1$	$\varepsilon_2$	$q''$ (W/m <sup>2</sup> )
air	0.95	0.95	106
	0.05	0.05	82.3
	0.05	0.95	83.2
argon	0.95	0.95	97.5
	0.05	0.05	66.5
	0.05	0.95	67.7

<

**COMMENTS:** (1) Switching the gas from air to argon reduces the heat flux in all cases. (2) Applying a low-emissivity coating to the glass reduces the heat flux in all cases. However, coating the interior surfaces of both glass sheets provides little benefit beyond that of coating one surface only. (3) If the gap between the glass sheets could be evacuated so that conduction in the gas becomes negligible, the heat flux through the window would be reduced significantly, to values of 72.6 and 6.98 and 3.67 W/m<sup>2</sup> for the cases 1, 2 and 3, respectively. (4) Natural convection in the gap was ignored. Is this a good assumption? (5) Radiation at the external surfaces of the glass sheets was ignored. Is this a good assumption?

## PROBLEM 13.102

**KNOWN:** Electrical conductors in the form of parallel plates having one edge mounted to a ceramic insulated base. Plates exposed to large, isothermal surroundings,  $T_{sur}$ . Operating temperature is  $T_1 = 500$  K.

**FIND:** (a) Electrical power dissipated in a conductor plate per unit length,  $q'_1$ , considering only radiative exchange with the surroundings; temperature of the ceramic insulated base  $T_2$ ; and, (b)  $q'_1$  and  $T_2$  when the surfaces experience convection with an air stream at  $T_\infty = 300$  K and a convection coefficient of  $h = 24$  W/m<sup>2</sup>·K.

**SCHEMATIC:**

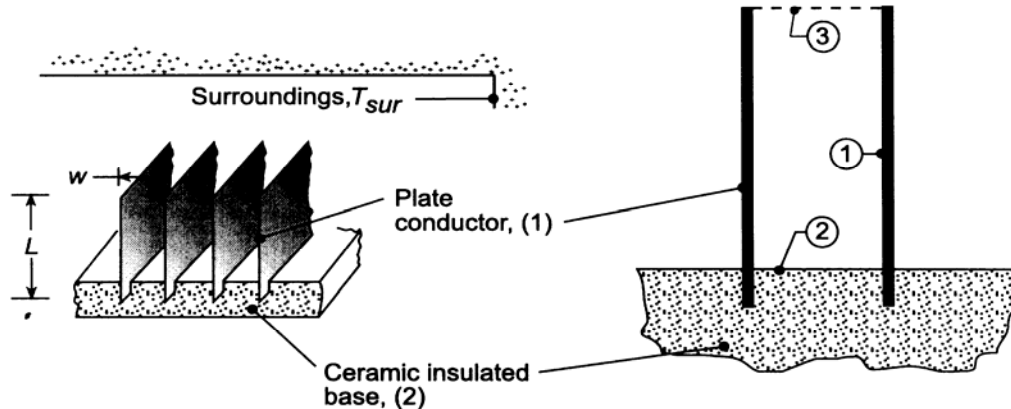

**ASSUMPTIONS:** (1) Conductor surfaces are diffuse, gray, (2) Conductor and ceramic insulated base surfaces have uniform temperatures and radiosities, (3) Surroundings are large, isothermal.

**ANALYSIS:** (a) Define the opening between the conductivities as the hypothetical area  $A_3$  at the temperature of the surroundings,  $T_{sur}$ , with an emissivity  $\epsilon_3 = 1$  since all the radiation incident on the area will be absorbed. The conductor (1)-base (2)-opening (3) form a three surface enclosure with one surface reradiating (2). From Eq. 13.30, the net radiation leaving the conductor surface  $A_1$  is

$$q_1 = \frac{E_{b1} - E_{b3}}{\frac{1 - \epsilon_1}{\epsilon_1 A_1} + \frac{1}{A_1 F_{13} + [(1/A_1 F_{12}) + (1/A_3 F_{32})]^{-1}} + \frac{1 - \epsilon_3}{\epsilon_3 A_3}} \quad (1)$$

where  $E_{b1} = \sigma T_1^4$  and  $E_{b3} = \sigma T_3^4 = J_3 = 5.67 \times 10^{-8}$  W/m<sup>2</sup>·K<sup>4</sup>  $\times (300 \text{ K})^4 = 459$  W/m<sup>2</sup>. The view factors are evaluated as follows:

$F_{32}$ : use the relation for two aligned parallel rectangles, Table 13.2 or Fig. 13.4,

$$\bar{X} = X/L = w/L = 10/40 = 0.25 \quad \bar{Y} = Y/L = \infty$$

$$F_{32} = 0.1231$$

$F_{13}$ : applying reciprocity between  $A_1$  and  $A_3$ , where  $A_1 = 2L\ell = 2 \times 0.040 \text{ m} \ell = 0.080 \ell$  and  $A_3 = w\ell = 0.010 \ell$  and  $\ell$  is the length of the conductors normal to the page,  $\ell \gg L$  or  $w$ ,

$$F_{13} = \frac{A_3 F_{31}}{A_1} = 0.010 \ell \times 0.8769 / 0.080 \ell = 0.1096$$

where  $F_{31}$  can be obtained by using the summation rule on  $A_3$ ,

$$F_{31} = 1 - F_{32} = 1 - 0.1231 = 0.8769$$

$F_{12}$ : by symmetry

$$F_{12} = F_{13} = 0.1096$$

Continued ...

### PROBLEM 13.102 (Cont.)

Substituting numerical values into Eq. (1), the net radiation leaving the conductor is

$$q_1 = \frac{5.67 \times 10^{-8} \text{ W/m}^2 \cdot \text{K}^4 (500^4 - 300^4) \text{ K}^4}{\frac{1-0.8}{0.8 \times 0.080 \ell} + \frac{1}{0.080 \ell \times 0.1096 + [(1/0.080 \ell \times 0.1096) + (1/0.010 \ell \times 0.123)]^{-1}} + 0}$$

$$q'_1 = q_1 / \ell = \frac{(3544 - 459.3) \text{ W}}{3.1250 + 101.557 + 0} = 29.5 \text{ W/m} \quad <$$

From Eq. 13.19,

$$J_1 = -q'_1 \left[ \frac{1 - \epsilon_1}{\epsilon_1 2L} \right] + \sigma T_1^4$$

$$= -29.5 \text{ W/m}^2 \left[ \frac{1 - 0.8}{0.8 \times 2 \times 0.04 \text{ m}} \right] + 5.67 \times 10^{-8} \text{ W/m}^2 \cdot \text{K}^4 \times (500 \text{ K})^4$$

$$= 3452 \text{ W/m}^2$$

and from Eq. 13.31,

$$J_2 = \frac{J_1 A_1 F_{12} + J_3 A_3 F_{32}}{A_1 F_{12} + A_3 F_{32}} = \frac{3452 \times 2 \times 0.040 \times 0.1096 + 459 \times 0.010 \times 0.1231}{2 \times 0.040 \times 0.1096 + 0.010 \times 0.1231} = 3060 \text{ W/m}^2$$

which yields

$$T_2 = \left( \frac{J_2}{\sigma} \right)^{1/4} = \left( \frac{3060 \text{ W/m}^2}{5.67 \times 10^{-8} \text{ W/m}^2 \cdot \text{K}^4} \right)^{1/4} = 482 \text{ K} \quad <$$

(b) Consider now convection processes occurring at the conductor (1) and base (2) surfaces, and perform energy balances as illustrated in the schematic below.

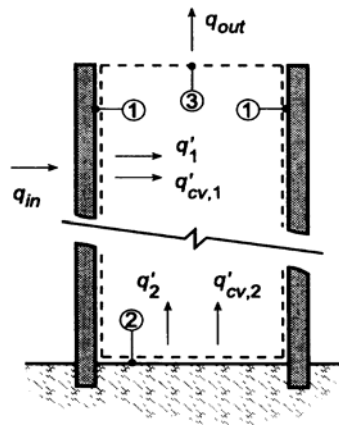

*Surface 1:* The heat rate from the conductor includes convection and the net radiation heat rates,

$$q_{in} = q_{cv,1} + q_1 = h A_1 (T_1 - T_\infty) + \frac{E_{b1} - J_1}{(1 - \epsilon_1) / \epsilon_1 A_1} \quad (2)$$

Continued...



### PROBLEM 13.102 (Cont.)

and the radiosity  $J_1$  can be determined from the radiation energy balance, Eq. 13.15,

$$\frac{E_{b1} - J_1}{(1 - \varepsilon_1) / \varepsilon_1 A_1} = \frac{J_1 - J_2}{1 / A_1 F_{12}} + \frac{J_1 - J_3}{1 / A_1 F_{13}} \quad (3)$$

where  $J_3 = E_{b3} = \sigma T_3^4$  since  $A_3$  is black.

*Surface 2:* Since the surface is insulated (adiabatic), the energy balance has the form

$$0 = q_{cv,2} + q_2 = hA_2(T_2 - T_\infty) + \frac{E_{b2} - J_2}{1 - \varepsilon_2 / \varepsilon_2 A_2} \quad (4)$$

and the radiosity  $J_2$  can be determined from the radiation energy balance, Eq. 13.21,

$$\frac{E_{b2} - J_2}{(1 - \varepsilon_2) / \varepsilon_2 A_2} = \frac{J_2 - J_1}{1 / A_2 F_{21}} + \frac{J_2 - J_3}{1 / A_2 F_{23}} \quad (5)$$

There are 4 equations, Eqs. (2-5), with 4 unknowns:  $J_1$ ,  $J_2$ ,  $T_2$  and  $q_1$ . Substituting numerical values, the simultaneous solution to the set yields

$$J_1 = 3417 \text{ W/m}^2 \quad J_2 = 1745 \text{ W/m}^2 \quad T_2 = 352 \text{ K} \quad q'_{in} = 441 \text{ W/m} \quad <$$

**COMMENTS:** (1) The effect of convection is substantial, increasing the heat removal rate from 29.5 W to 441 W for the combined modes. (2) With the convection process, the current carrying capacity of the conductors can be increased. Another advantage is that, with the presence of convection, the ceramic base operates at a cooler temperature: 352 K vs. 482 K.

### PROBLEM 13.103

**KNOWN:** Surface temperature and spectral radiative properties. Temperature of ambient air. Solar irradiation or temperature of shield.

**FIND:** (a) Convection heat transfer coefficient when surface is exposed to solar radiation, (b) Temperature of shield needed to maintain prescribed surface temperature.

**SCHEMATIC:**

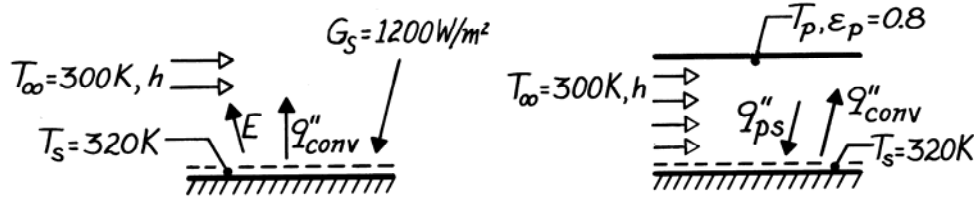

**ASSUMPTIONS:** (1) Surface is diffuse ( $\alpha_\lambda = \epsilon_\lambda$ ), (2) Bottom of surface is adiabatic, (3) Atmospheric irradiation is negligible, (4) With shield, convection coefficient is unchanged and radiation losses at ends are negligible (two-surface enclosure).

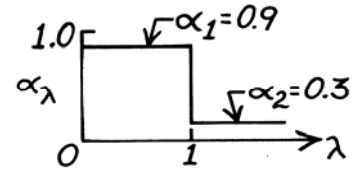

**ANALYSIS:** (a) From a surface energy balance,

$$\alpha_S G_S = \epsilon_S \sigma T_S^4 + h(T_S - T_\infty).$$

Emission occurs mostly at long wavelengths, hence  $\epsilon_S = \alpha_2 = 0.3$ . However,

$$\alpha_S = \frac{\int_0^\infty \alpha_\lambda E_{\lambda,b}(\lambda, 5800 \text{ K}) d\lambda}{E_b} = \alpha_1 F_{(0-1\mu\text{m})} + \alpha_2 F_{(1-\infty)}$$

and from Table 12.1 at  $\lambda T = 5800 \mu\text{m}\cdot\text{K}$ ,  $F_{(0-1\mu\text{m})} = 0.720$  and hence,  $F_{(1-\infty)} = 0.280$  giving  $\alpha = 0.9 \times 0.72 + 0.3 \times 0.280 = 0.732$ .

Hence

$$h = \frac{\alpha_S G_S - \epsilon_S \sigma T_S^4}{T_S - T_\infty} = \frac{0.732(1200 \text{ W/m}^2) - 0.3 \times 5.67 \times 10^{-8} \text{ W/m}^2 \cdot \text{K}^4 (320 \text{ K})^4}{20 \text{ K}}$$

$$h = 35 \text{ W/m}^2 \cdot \text{K}. \quad <$$

(b) Since the plate emits mostly at long wavelengths,  $\alpha_s = \epsilon_s = 0.3$ . Hence radiation exchange is between two diffuse-gray surfaces.

$$q''_{ps} = \frac{\sigma(T_p^4 - T_s^4)}{1/\epsilon_p + 1/\epsilon_s - 1} = q''_{\text{conv}} = h(T_s - T_\infty)$$

$$T_p^4 = (h/\sigma)(T_s - T_\infty)(1/\epsilon_p + 1/\epsilon_s - 1) + T_s^4$$

$$T_p^4 = \frac{35 \text{ W/m}^2 \cdot \text{K}(20 \text{ K})}{5.67 \times 10^{-8} \text{ W/m}^2 \cdot \text{K}^4} \left( \frac{1}{0.8} + \frac{1}{0.3} - 1 \right) + (320 \text{ K})^4 \quad T_p = 484 \text{ K}. \quad <$$

**COMMENTS:** For  $T_p = 484 \text{ K}$  and  $\lambda = 1 \mu\text{m}$ ,  $\lambda T = 484 \mu\text{m}\cdot\text{K}$  and  $F_{(0-\lambda)} = 0.000$ . Hence assumption of  $\alpha_s = 0.3$  is excellent.

### PROBLEM 13.104

**KNOWN:** Long uniform rod with volumetric energy generation positioned coaxially within a larger circular tube maintained at 500°C.

**FIND:** (a) Center  $T_1(0)$  and surface  $T_{1s}$  temperatures of the rod for evacuated space, (b)  $T_1(0)$  and  $T_{1s}$  for airspace, (c) Effect of tube diameter and emissivity on  $T_1(0)$  and  $T_{1s}$ .

**SCHEMATIC:**

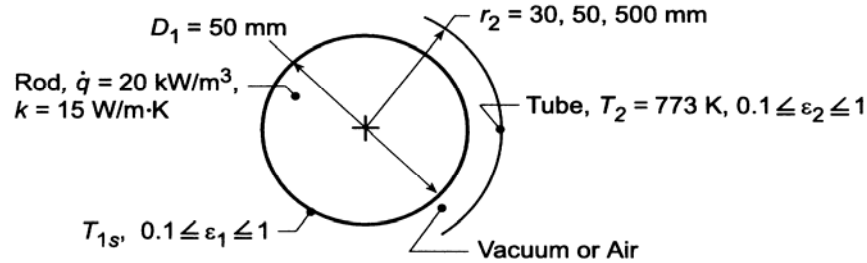

**ASSUMPTIONS:** (1) All surfaces are diffuse-gray.

**PROPERTIES:** Table A-4, Air ( $\bar{T} = 780$  K):  $\nu = 81.5 \times 10^{-6} \text{ m}^2/\text{s}$ ,  $k = 0.0563 \text{ W/m}\cdot\text{K}$ ,  $\alpha = 115.6 \times 10^{-6} \text{ m}^2/\text{s}$ ,  $\beta = 0.00128 \text{ K}^{-1}$ ,  $\text{Pr} = 0.706$ .

**ANALYSIS:** (a) The net heat exchange by radiation between the rod and the tube is

$$q'_{12} = \frac{\sigma(T_1^4 - T_2^4)}{(1 - \epsilon_1)/\epsilon_1 \pi D_1 + 1/\pi D_1 F_{12} + (1 - \epsilon_2)/\epsilon_2 \pi D_2} \quad (1)$$

and, from an energy balance on the rod,  $-\dot{E}'_{\text{out}} + \dot{E}'_{\text{gen}} = 0$ , or

$$q'_{12} = \dot{q}(\pi D_1^2 / 4). \quad (2)$$

Combining Eqs. (1) and (2) and substituting numerical values, with  $F_{12} = 1$ , we obtain

$$\begin{aligned} \dot{q} &= \frac{4}{D_1} \left[ \frac{\sigma(T_1^4 - T_2^4)}{(1 - \epsilon_1)/\epsilon_1 + 1 + [(1 - \epsilon_2)/\epsilon_2](D_1/D_2)} \right] \\ 20 \times 10^3 \frac{\text{W}}{\text{m}^3} &= \frac{4}{0.050 \text{ m}} \left[ \frac{5.67 \times 10^{-8} \text{ W/m}^2 \cdot \text{K}^4 (T_{1s}^4 - 773^4) \text{ K}^4}{(1 - 0.2)/0.2 + 1 + [(1 - 0.2)/0.2](0.050/0.060)} \right] \\ &= 54.4 \times 10^{-8} (T_{1s}^4 - 773^4) \text{ W/m}^3 \end{aligned}$$

$$T_{1s} = 792 \text{ K.} \quad <$$

From Eq. 3.53, the rod center temperature is

$$\begin{aligned} T_1(0) &= \frac{\dot{q}(D_1/2)^2}{4k} + T_{1s} \\ T_1(0) &\approx \frac{20 \times 10^3 \text{ W/m}^3 (0.050 \text{ m}/2)^2}{4 \times 15 \text{ W/m}\cdot\text{K}} + 792 \text{ K} = 0.21 \text{ K} + 792 \text{ K} = 792.2 \text{ K.} \quad < \end{aligned}$$

(b) The convection heat rate is given by Eqs. 9.58 through 9.60. The length scale is  $L_c = 2[\ln(0.06/0.05)]^{4/3} / (0.025 \text{ m}^{-3/5} + 0.030 \text{ m}^{-3/5})^{5/3} = 0.0018 \text{ m}$ . Assuming a maximum possible value of  $(T_{s1} - T_2) = 19 \text{ K}$ ,  $\text{Ra}_c = g\beta(T_{s1} - T_2)L_c^3/\nu\alpha = 9.8 \text{ m/s}^2(0.00128 \text{ K}^{-1})19 \text{ K}(0.0018 \text{ m})^3/(81.5 \times 10^{-6} \text{ m}^2/\text{s} \times 115.6 \times 10^{-6} \text{ m}^2/\text{s}) = 0.142$  and  $k_{\text{eff}}/k = 0.386 \times [0.706/(0.861 + 0.706)]^{1/4} (0.142)^{1/4} = 0.194$ . Since  $k_{\text{eff}}/k$  is predicted to be less than unity, conduction occurs within the gap.

Continued ...

### PROBLEM 13.104 (Cont.)

Hence, from Eq. 3.32,

$$q'_{\text{cond}} = \frac{2\pi k(T_{1s} - T_2)}{\ln(r_2/r_1)} = \frac{2\pi(0.0563 \text{ W/m}\cdot\text{K})(T_{1s} - 773) \text{ K}}{\ln(30/25)} = 1.94(T_{1s} - 773)$$

The energy balance then becomes  $\dot{q}(\pi D_1^2/4) = q'_{12} + q'_{\text{cond}}$ , or

$$\dot{q} = \left(4/\pi D_1^2\right)(q'_{12} + q'_{\text{cond}})$$

$$2 \times 10^4 = \left[54.4 \times 10^{-8} (T_{1s}^4 - 773^4) + 988(T_{1s} - 773)\right]$$

$$T_{1s} = 783 \text{ K} \qquad T_1(0) = 783.2 \text{ K} \qquad <$$

(c) Entering the foregoing model and the prescribed properties of air into the *IHT* workspace, the parametric calculations were performed for  $D_2 = 0.06 \text{ m}$  and  $D_2 = 0.10 \text{ m}$ . For  $D_2 = 1.0 \text{ m}$ ,  $Ra_c^* > 100$  and heat transfer across the airspace is by free convection, instead of conduction. In this case, convection was evaluated by entering Eqs. 9.58 – 9.60 into the workspace. The results are plotted as follows.

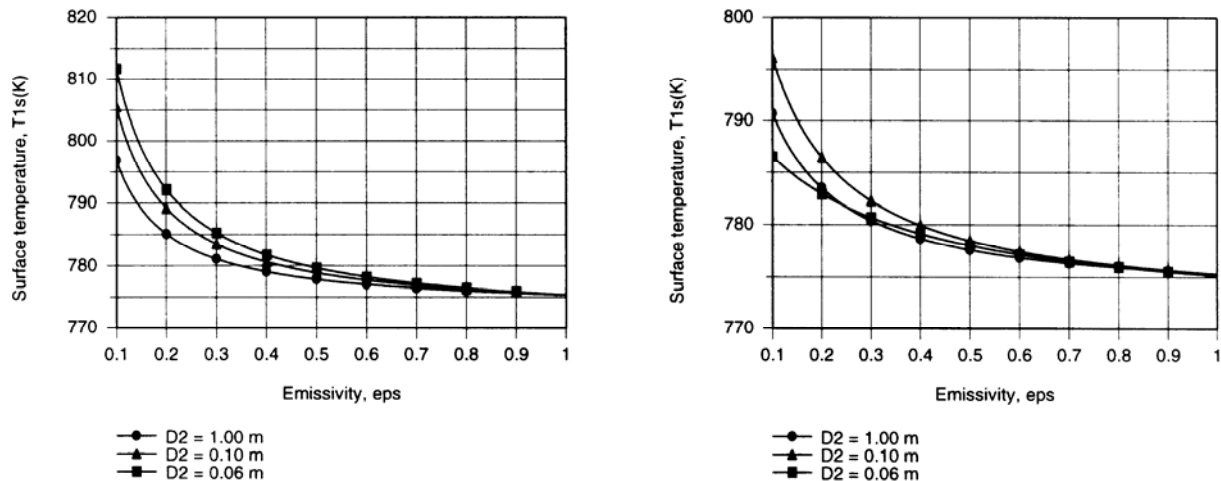

The first graph corresponds to the evacuated space, and the surface temperature decreases with increasing  $\epsilon_1 = \epsilon_2$ , as well as with  $D_2$ . The increased emissivities enhance the effectiveness of emission at surface 1 and absorption at surface 2, both which have the effect of reducing  $T_{1s}$ . Similarly, with increasing  $D_2$ , more of the radiation emitted from surface 1 is ultimately absorbed at 2 (less of the radiation reflected by surface 2 is intercepted by 1). The second graph reveals the expected effect of a reduction in  $T_{1s}$  with inclusion of conduction or convection heat transfer across the air. For small emissivities ( $\epsilon_1 = \epsilon_2 < 0.2$ ), conduction across the air is significant relative to radiation, and the small conduction resistance corresponding to  $D_2 = 0.06 \text{ m}$  yields the smallest value of  $T_{1s}$ . However, with increasing  $\epsilon$ , conduction/convection effects diminish relative to radiation and the trend reverts to one of decreasing  $T_{1s}$  with increasing  $D_2$ .

**COMMENTS:** For this situation, the temperature variation *within* the rod is small and independent of surface conditions.

### PROBLEM 13.105

**KNOWN:** Side wall and gas temperatures for adjoining semi-cylindrical ducts. Gas flow convection coefficients.

**FIND:** (a) Temperature of intervening wall, (b) Verification of gas temperature on one side.

**SCHEMATIC:**

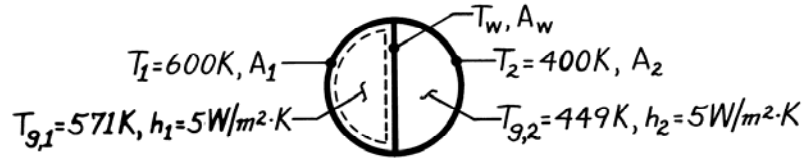

**ASSUMPTIONS:** (1) All duct surfaces may be approximated as blackbodies, (2) Fully developed conditions, (3) Negligible temperature difference across intervening wall, (4) Gases are nonparticipating media.

**ANALYSIS:** (a) Applying an energy balance to a control surface about the wall yields

$$\dot{E}_{\text{in}} = \dot{E}_{\text{out}}$$

Assuming  $T_{g,1} > T_w > T_{g,2}$ , it follows that

$$q_{\text{rad}(1 \rightarrow w)} + q_{\text{conv}(g1 \rightarrow w)} = q_{\text{rad}(w \rightarrow 2)} + q_{\text{conv}(w \rightarrow g2)}$$

$$A_1 F_{1w} \sigma (T_1^4 - T_w^4) + h A_w (T_{g,1} - T_w) = A_w F_{w2} \sigma (T_w^4 - T_2^4) + h A_w (T_w - T_{g,2})$$

and with

$$A_1 F_{1w} = A_w F_{w1} = A_w F_{w2} = A_w$$

and substituting numerical values,

$$2\sigma T_w^4 + 2hT_w = \sigma (T_1^4 + T_2^4) + h(T_{g,1} + T_{g,2})$$

$$11.34 \times 10^{-8} T_w^4 + 10T_w = 13,900.$$

which yields

$$T_w \approx 526 \text{ K.} \quad \leftarrow$$

(b) Applying an energy balance to a control surface about the hot gas (g1) yields

$$\dot{E}_{\text{in}} = \dot{E}_{\text{out}}$$

$$hA_1 (T_1 - T_{g1}) = hA_w (T_{g1} - T_w)$$

or

$$T_1 - T_{g1} = [D / (\pi D / 2)] (T_{g1} - T_w)$$

$$29^\circ\text{C} = 29^\circ\text{C.} \quad \leftarrow$$

**COMMENTS:** Since there is no change in any of the temperatures in the axial direction, this scheme simply provides for energy transfer from side wall 1 to side wall 2.

### PROBLEM 13.106

**KNOWN:** Dimensions of stainless steel pillar and nominal glass temperatures. Contact resistance between pillar and glass. Emissivity of inner glass surfaces. Unit area dimensions.

**FIND:** Ratio of conduction to radiation heat transfer through a unit area.

**SCHEMATIC:**

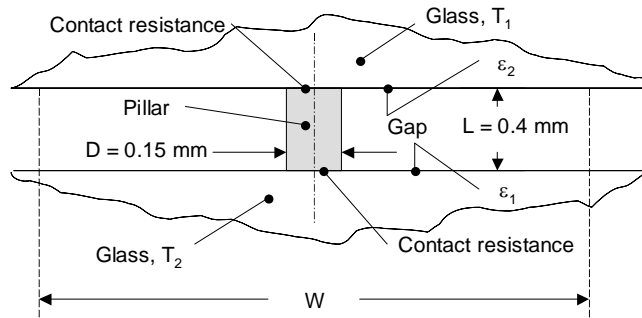

**ASSUMPTIONS:** (1) Steady-state conditions, (2) Constant properties, (3) Diffuse-gray surfaces, (4) Two-dimensional conduction, (5) Pillar does not affect radiation heat transfer ( $D/W \ll 1$ ), (6) Radiation heat transfer does not affect conduction in low-emissivity stainless steel pillar.

**PROPERTIES:** Table A.1, AISI 302 stainless steel (300 K):  $k_p = 15.1 \text{ W/m}\cdot\text{K}$ . Table A.3, plate glass (300 K):  $k_g = 1.4 \text{ W/m}\cdot\text{K}$ .

**ANALYSIS:** The conduction and radiation processes are decoupled. Conduction through the pillar results in a depression of the glass temperature in the immediate vicinity of the pillar. This is associated with a constriction resistance within each glass sheet. Therefore, the resistance network consists of two constriction resistances, two contact resistances, and a conduction resistance through the pillar as shown below.

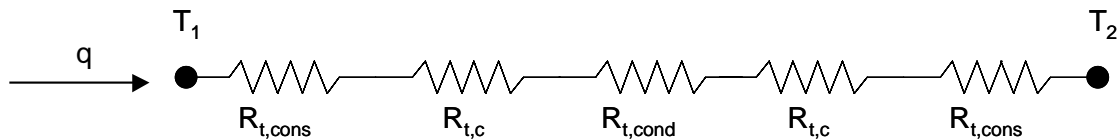

Using the shape factor for Case 10 of Table 4.1(a), the resistances are:

$$R_{t,\text{cons}} = 1/(Sk_g) = 1/(2Dk_g) = 1/(2 \times 0.15 \times 10^{-3} \text{ m} \times 1.4 \text{ W/m}\cdot\text{K}) = 2381 \text{ K/W}$$

$$R_{t,c} = R_{t,c}'' / A_p = 1.5 \times 10^{-6} \text{ m}^2 \cdot \text{K/W} / \left[ \pi \times (0.15 \times 10^{-3} \text{ m})^2 / 4 \right] = 84.88 \text{ K/W}$$

$$R_{t,\text{cond}} = L/k_p A_p = L/k_p \left( \pi D_p^2 / 4 \right) = 0.4 \times 10^{-3} \text{ m} / \left[ 15.1 \text{ W/m}\cdot\text{K} \times \pi \times (0.15 \times 10^{-3} \text{ m})^2 / 4 \right] = 1500 \text{ K/W}$$

Therefore, the total resistance is

$$R_{\text{tot}} = 2(R_{t,\text{cons}} + R_{t,c}) + R_{t,\text{cond}} = 2 \times (2381 \text{ K/W} + 84.88 \text{ K/W}) + 1500 \text{ K/W} = 6430 \text{ K/W}$$

and the conduction through an individual pillar is

$$q_{\text{cond}} = (T_1 - T_2)/R_{\text{tot}} = [20 - (-10)^\circ\text{C}] / [6430 \text{ K/W}] = 4.66 \times 10^{-3} \text{ W} = 4.66 \text{ mW}$$

Continued...

### PROBLEM 13.106 (Cont.)

For  $W = 10$  mm, net radiation heat rate between the glass sheets through the unit area is

$$q_{\text{rad},10} = \frac{W^2 \sigma (T_1^4 - T_2^4)}{\frac{1}{\varepsilon_1} + \frac{1}{\varepsilon_2} - 1} = \frac{(0.01 \text{ m})^2 5.67 \times 10^{-8} \text{ W/m}^2 \cdot \text{K}^4 (293\text{K}^4 - 263\text{K}^4)}{\frac{1}{0.95} + \frac{1}{0.05} - 1} = 0.73 \times 10^{-3} \text{ W} = 0.73 \text{ mW}$$

Similarly, for  $W = 20$  and  $30$  mm,  $q_{\text{rad},20} = 2.9 \text{ mW}$  ;  $q_{\text{rad},30} = 6.6 \text{ mW}$ . Therefore, the ratio of conduction to radiation through a unit area is

$$R = 6.38, 1.59, \text{ and } 0.709 \quad <$$

for  $W = 10, 20$  and  $30$  mm, respectively.

**COMMENTS:** (1) Although the pillars are small, they account for a large amount of the total heat transfer through the window, especially for small values of  $W$ . (2) The radiation and conduction effects become coupled in the immediate vicinity of the pillar. (3) Temperature differences also exist across the glass sheets, however these differences are relatively small. For  $W = 10$  mm, and for a glass sheet thickness of  $t = 6$  mm, the temperature difference across one sheet of glass may be estimated to be  $\Delta T = (q_{\text{rad},10} + q_{\text{cond}})t / (k_g W^2) = (0.73 \times 10^{-3} \text{ W} + 4.66 \times 10^{-3} \text{ W}) \times 0.006 \text{ m} / (1.4 \text{ W/m}\cdot\text{K} \times 0.01 \text{ m} \times 0.01 \text{ m}) = 0.23 \text{ K}$ . (4) Heat transfer through the window can be reduced by increasing the pillar length. However, practical limitations exist since sealing the edges of the window in order to maintain a high vacuum becomes more difficult as  $L$  increases. (5) See Manz, Brunner and Wullschleger, "Triple Vacuum Glazing: Heat Transfer and Basic Design Constraints," *Solar Energy*, Vol. 80, pp. 1632-1642, 2006 for more information.

### PROBLEM 13.107

**KNOWN:** Temperature, dimensions and arrangement of heating elements between two large parallel plates, one insulated and the other of prescribed temperature. Convection coefficients associated with elements and bottom surface.

**FIND:** (a) Temperature of gas enclosed by plates, (b) Element electric power requirement, (c) Rate of heat transfer to  $1 \text{ m} \times 1 \text{ m}$  section of panel.

**SCHEMATIC:**

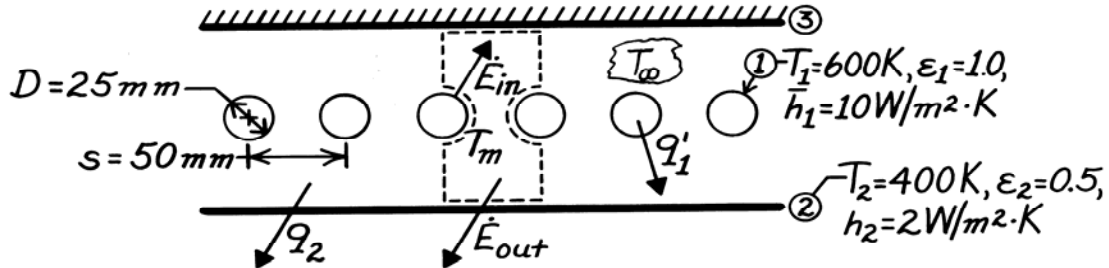

**ASSUMPTIONS:** (1) Diffuse-gray surfaces, (2) Negligible end effects since the surfaces form an enclosure, (3) Gas is nonparticipating, (4) Surface 3 is reradiating with negligible conduction and convection.

**ANALYSIS:** (a) Performing an energy balance for a unit control surface about the gas space,

$$\dot{E}_{in} - \dot{E}_{out} = 0.$$

$$\bar{h}_1 \pi D (T_1 - T_m) - \bar{h}_2 s (T_m - T_2) = 0$$

$$T_m = \frac{\bar{h}_1 \pi D T_1 + \bar{h}_2 s T_2}{\bar{h}_1 \pi D + \bar{h}_2 s} = \frac{10 \text{ W/m}^2 \cdot \text{K} \pi (0.025 \text{ m}) 600 \text{ K} + 2 \text{ W/m}^2 \cdot \text{K} (0.05 \text{ m}) 400 \text{ K}}{10 \text{ W/m}^2 \cdot \text{K} \pi (0.025 \text{ m}) + 2 \text{ W/m}^2 \cdot \text{K} (0.05 \text{ m})}$$

$$T_m = 577 \text{ K.}$$

(b) The equivalent thermal circuit is

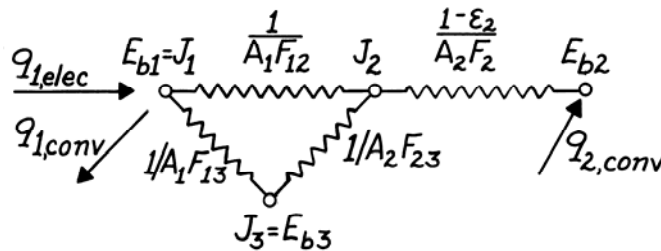

The energy balance on surface 1 is

$$q'_{1,elec} = q'_{1,conv} + q'_{1,rad}$$

where  $q'_{1,rad}$  can be evaluated by considering a unit cell of the form

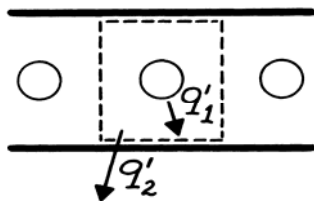

$$A'_1 = \pi D = \pi (0.025 \text{ m}) = 0.0785 \text{ m}^2$$

$$A'_2 = A'_3 = s = 0.05 \text{ m}^2$$

Continued ...



**PROBLEM 13.107 (Cont.)**

The view factors are:

$$F_{21} = 1 - \left[ 1 - (D/s)^2 \right]^{1/2} + (D/s) \tan^{-1} \left[ \left( s^2 - D^2 \right) / D^2 \right]^{1/2}$$

$$F_{21} = 1 - \left[ 1 - 0.25 \right]^{1/2} + 0.5 \tan^{-1} (4 - 1)^{1/2} = 0.658 = F_{31}$$

$$F_{23} = 1 - F_{21} = 0.342 = F_{32}.$$

For the unit cell,

$$A'_2 F_{21} = s F_{21} = 0.05 \text{ m} \times 0.658 = 0.0329 \text{ m} = A'_1 F_{12} = A'_3 F_{31} = A'_1 F_{13}$$

$$A'_2 F_{23} = s F_{23} = 0.05 \text{ m} \times 0.342 = 0.0171 \text{ m} = A'_3 F_{32}.$$

Hence,

$$q'_{1,\text{rad}} = \frac{E_{b1} - E_{b2}}{R'_{\text{equiv}} + (1 - \varepsilon_2) / \varepsilon_2 A'_2}$$

$$R'_{\text{equiv}} = A'_1 F_{12} + \frac{1}{1/A'_1 F_{13} + 1/A'_2 F_{23}} = \left( 0.0329 + \frac{1}{(0.0329)^{-1} + (0.0171)^{-1}} \right) \text{ m}$$

$$R'_{\text{equiv}} = 22.6 \text{ m}^{-1}.$$

Hence

$$q'_{1,\text{rad}} = \frac{5.67 \times 10^{-8} \text{ W/m}^2 \cdot \text{K}^4 (600^4 - 400^4) \text{ K}^4}{[22.6 + (1 - 0.5) / 0.5 \times 0.05] \text{ m}^{-1}} = 138.3 \text{ W/m}$$

$$q'_{1,\text{conv}} = \bar{h}_1 \pi D (T_1 - T_m) = 10 \text{ W/m}^2 \cdot \text{K} \pi (0.025 \text{ m}) (600 - 577) \text{ K} = 17.8 \text{ W/m}$$

$$q'_{1,\text{elec}} = (138.3 + 17.8) \text{ W/m} = 156 \text{ W/m}. \quad <$$

(c) Since all energy added via the heating elements must be transferred to surface 2,

$$q'_2 = q'_1.$$

Hence, since there are 20 elements in a 1 m wide strip,

$$q_2(1\text{m} \times 1\text{m}) = 20 \times q'_{1,\text{elec}} = 3120 \text{ W}. \quad <$$

**COMMENTS:** The bottom panel would have to be cooled (from below) by a heat sink which could dissipate  $3120 \text{ W/m}^2$ .

### PROBLEM 13.108

**KNOWN:** Two large parallel plates, temperature of each plate. Bare plate and paint emissivities, thickness of paint layers.

**FIND:** (a) Radiation heat flux across the gap for  $\epsilon_1 = \epsilon_2 = \epsilon_s = 0.85$ , (b) Radiation heat flux across the gap for  $\epsilon_1 = \epsilon_2 = \epsilon_p = 0.98$ , (c) Radiation heat flux across the gap when the paint layer thickness is  $L = 2$  mm and paint thermal conductivity is  $k = 0.21$  W/m·K, (d) Plot of the radiation heat flux across the gap as a function of the surface emissivity over the range  $0.05 \leq \epsilon_s \leq 0.95$ . Show the heat flux of the painted surface with thin and thick paint layers on the same graph.

**SCHEMATIC:**

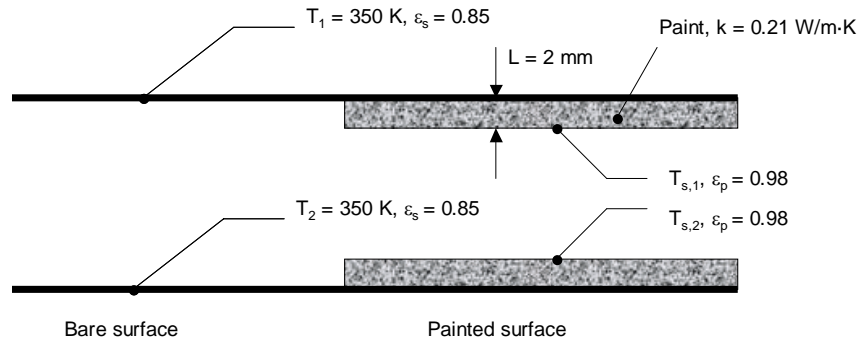

**ASSUMPTIONS:** (1) One-dimensional heat transfer, (2) Diffuse, gray surfaces, (3) Negligible contact resistance between the plate and the paint.

**PROPERTIES:** Paint (given):  $k = 0.21$  W/m·K.

**ANALYSIS:** (a) The radiation heat flux across the gap is

$$q_{\text{rad}}'' = \frac{\sigma(T_1^4 - T_2^4)}{\frac{1}{\epsilon_1} + \frac{1}{\epsilon_2} - 1} = \frac{5.67 \times 10^{-8} \frac{\text{W}}{\text{m}^2 \cdot \text{K}^4} \times (350^4 - 300^4) \text{K}^4}{\frac{1}{0.85} + \frac{1}{0.85} - 1} = 289.4 \frac{\text{W}}{\text{m}^2} \quad (1) <$$

(b) With  $\epsilon_1 = \epsilon_2 = \epsilon_p = 0.98$ ,

$$q_{\text{rad}}'' = \frac{5.67 \times 10^{-8} \frac{\text{W}}{\text{m}^2 \cdot \text{K}^4} \times (350^4 - 300^4) \text{K}^4}{\frac{1}{0.98} + \frac{1}{0.98} - 1} = 376.2 \frac{\text{W}}{\text{m}^2} <$$

(c) After painting both surfaces, the thermal resistance network is

Continued...

### PROBLEM 13.108 (Cont.)

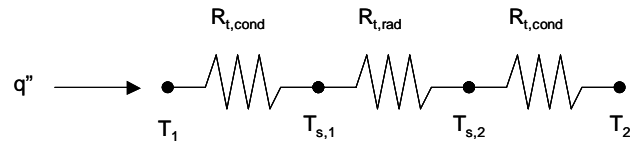

$$q'' = \frac{k_p}{L_p}(T_1 - T_{s,1}) = \frac{0.21 \frac{\text{W}}{\text{m} \cdot \text{K}}}{2 \times 10^{-3} \text{ m}}(350\text{K} - T_{s,1}) \quad (2)$$

$$q'' = \frac{\sigma(T_{s,1}^4 - T_{s,2}^4)}{\frac{1}{\varepsilon_p} + \frac{1}{\varepsilon_p} - 1} = \frac{5.67 \times 10^{-8} \frac{\text{W}}{\text{m}^2 \cdot \text{K}^4}}{\frac{1}{0.98} + \frac{1}{0.98} - 1} \quad (3)$$

$$q'' = \frac{k_p}{L_p}(T_{s,2} - T_2) = \frac{0.21 \frac{\text{W}}{\text{m} \cdot \text{K}}}{2 \times 10^{-3} \text{ m}}(T_{s,2} - 300\text{K}) \quad (4)$$

Solving Eqs. (2) through (4) simultaneously yields

$$T_{s,1} = 346.9 \text{ K}, T_{s,2} = 303.1 \text{ K}, q'' = q''_{\text{rad}} = q''_{\text{cond}} = 328.7 \frac{\text{W}}{\text{m}^2} \quad <$$

(d) Solving Eq. (1) over the range  $0.05 \leq \varepsilon \leq 0.95$  yields the following.

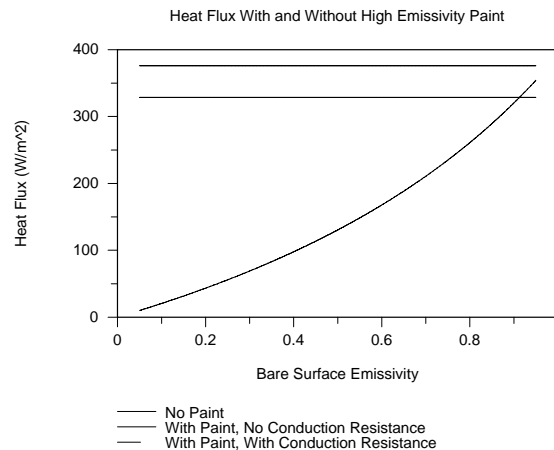

**COMMENTS:** (1) The paint is effective in increasing radiation heat transfer across the gap for all but very high emissivity bare surfaces. (2) Thick paint layers will result in significant thermal conduction resistances which, in turn, reduce heat transfer across the gap. (3) Use of paints is usually restricted to relatively low temperatures. (4) Thermal contact resistances may be large if flaking or peeling of the paint becomes significant.

### PROBLEM 13.109

**KNOWN:** Ceiling temperature of furnace. Thickness, thermal conductivity, and/or emissivities of alternative thermal insulation systems. Convection coefficient at outer surface and temperature of surroundings.

**FIND:** (a) Mathematical model for each system, (b) Temperature of outer surface  $T_{s,o}$  and heat loss  $q''$  for each system and prescribed conditions, (c) Effect of emissivity on  $T_{s,o}$  and  $q''$ .

**SCHEMATIC:**

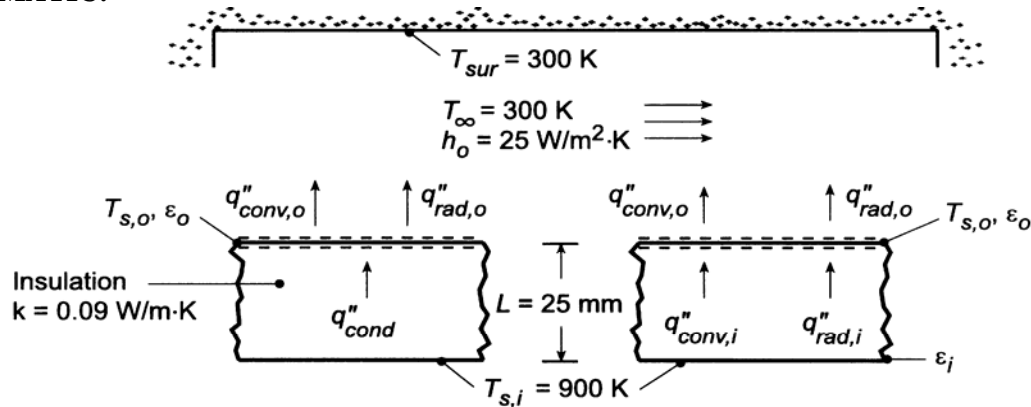

**ASSUMPTIONS:** (1) Steady-state, (2) Diffuse/gray surfaces, (3) Surroundings form a large enclosure about the furnace, (4) Radiation in air space corresponds to a two-surface enclosure of large parallel plates.

**PROPERTIES:** Table A-4, air ( $T_f = 730$  K):  $k = 0.055$  W/m·K,  $\alpha = 1.09 \times 10^{-4}$  m<sup>2</sup>/s,  $\nu = 7.62 \times 10^{-5}$  m<sup>2</sup>/s,  $\beta = 0.001335$  K<sup>-1</sup>, Pr = 0.702.

**ANALYSIS:** (a) To obtain  $T_{s,o}$  and  $q''$ , an energy balance must be performed at the outer surface of the shield.

*Insulation:*  $q''_{\text{cond}} = q''_{\text{conv},o} + q''_{\text{rad},o} = q''$

$$k \frac{(T_{s,i} - T_{s,o})}{L} = h_o (T_{s,o} - T_\infty) + \epsilon_o \sigma (T_{s,o}^4 - T_{\text{sur}}^4)$$

*Air Space:*  $q''_{\text{conv},i} + q''_{\text{rad},i} = q''_{\text{conv},o} + q''_{\text{rad},o} = q''$

$$h_i (T_{s,i} - T_{s,o}) + \frac{\sigma (T_{s,i}^4 - T_{s,o}^4)}{\frac{1}{\epsilon_i} + \frac{1}{\epsilon_o} - 1} = h_o (T_{s,o} - T_\infty) + \epsilon_o \sigma (T_{s,o}^4 - T_{\text{sur}}^4)$$

where Eq. 13.24 has been used to evaluate  $q''_{\text{rad},i}$  and  $h_i$  is given by Eq. 9.49

$$\overline{\text{Nu}}_L = \frac{h_i L}{k} = 0.069 \text{Ra}_L^{1/3} \text{Pr}^{0.074}$$

(b) For the prescribed conditions ( $\epsilon_i = \epsilon_o = 0.5$ ), the following results were obtained.

*Insulation:* The energy equation becomes

$$\frac{0.09 \text{ W/m} \cdot \text{K} (900 - T_{s,o}) \text{ K}}{0.025 \text{ m}} = 25 \text{ W/m}^2 \cdot \text{K} (T_{s,o} - 300) \text{ K} + 0.5 \times 5.67 \times 10^{-8} \text{ W/m}^2 \cdot \text{K}^4 (T_{s,o}^4 - 300^4) \text{ K}^4$$

Continued ...

### PROBLEM 13.109 (Cont.)

and a trial-and-error solution yields

$$T_{s,o} = 366 \text{ K} \quad q'' = 1920 \text{ W/m}^2 \quad \leftarrow$$

*Air-Space:* The energy equation becomes

$$\begin{aligned} h_i (900 - T_{s,o}) \text{ K} + \frac{5.67 \times 10^{-8} \text{ W/m}^2 \cdot \text{K}^4 (900^4 - T_{s,o}^4) \text{ K}^4}{3} \\ = 25 \text{ W/m}^2 \cdot \text{K} (T_{s,o} - 300) \text{ K} + 0.5 \times 5.67 \times 10^{-8} \text{ W/m}^2 \cdot \text{K}^4 (T_{s,o}^4 - 300^4) \text{ K}^4 \end{aligned}$$

where

$$h_i = \frac{0.055 \text{ W/m} \cdot \text{K}}{0.025 \text{ m}} 0.069 \text{ Ra}_L^{1/3} \text{ Pr}^{0.074} \quad (1)$$

and  $\text{Ra}_L = g\beta(T_{s,i} - T_{s,o})L^3/\alpha\nu$ . A trial-and-error solution, which includes reevaluation of the air properties, yields

$$T_{s,o} = 598 \text{ K} \quad q'' = 10,849 \text{ W/m}^2 \quad \leftarrow$$

The inner and outer heat fluxes are  $q''_{\text{conv},i} = 867 \text{ W/m}^2$ ,  $q''_{\text{rad},i} = 9982 \text{ W/m}^2$ ,  $q''_{\text{conv},o} = 7452 \text{ W/m}^2$ , and  $q''_{\text{rad},o} = 3397 \text{ W/m}^2$ .

(c) Entering the foregoing models into the *IHT* workspace, the following results were generated.

*Insulation:*

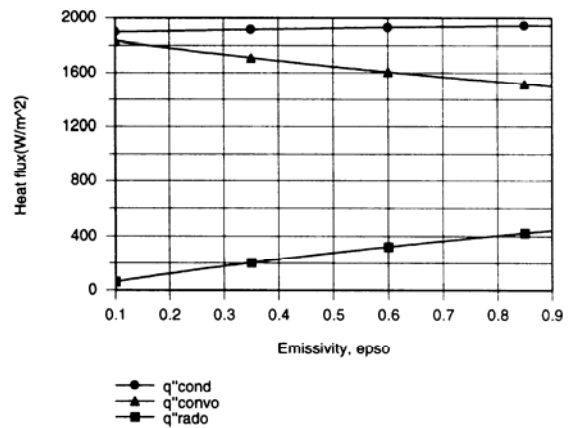
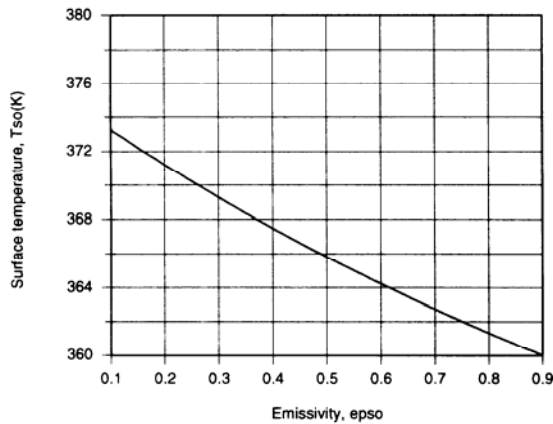

Continued ...

### PROBLEM 13.109 (Cont.)

As expected, the outer surface temperature decreases with increasing  $\epsilon_o$ . However, the reduction in  $T_{s,o}$  is not large since heat transfer from the outer surface is dominated by convection.

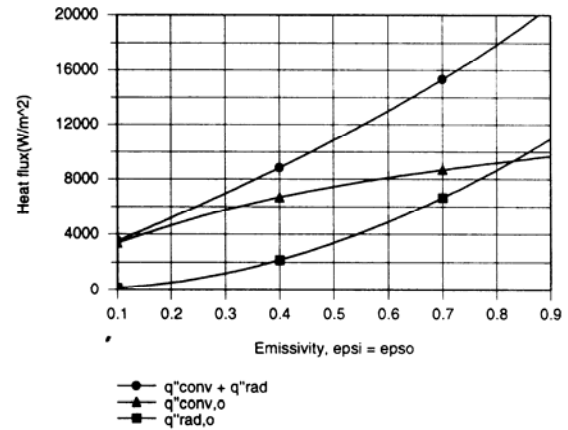
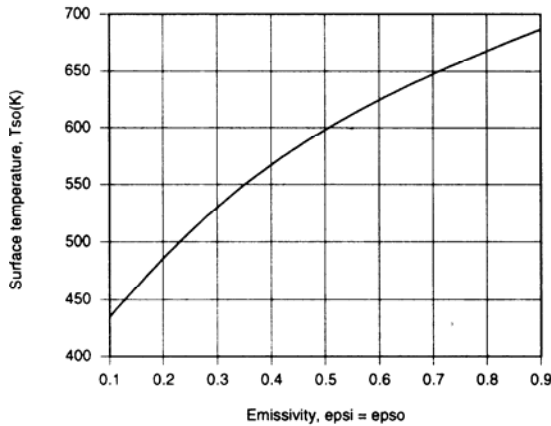

In this case  $T_{s,o}$  increases with increasing  $\epsilon_o = \epsilon_i$  and the effect is significant. The effect is due to an increase in radiative transfer from the inner surface, with  $q''_{rad,i} = q''_{conv,i} = 1750 \text{ W/m}^2$  for  $\epsilon_o = \epsilon_i = 0.1$  and  $q''_{rad,i} = 20,100 \text{ W/m}^2 \gg q''_{conv,i} = 523 \text{ W/m}^2$  for  $\epsilon_o = \epsilon_i = 0.9$ . With the increase in  $T_{s,o}$ , the total heat flux increases, along with the relative contribution of radiation ( $q''_{rad,o}$ ) to heat transfer from the outer surface.

**COMMENTS:** (1) With no insulation or radiation shield and  $\epsilon_i = 0.5$ , radiation and convection heat fluxes from the ceiling are  $18,370$  and  $15,000 \text{ W/m}^2$ , respectively. Hence, a significant reduction in the heat loss results from use of the insulation or the shield, although the insulation is clearly more effective.

(2) Rayleigh numbers associated with free convection in the air space are well below the lower limit of applicability of Eq. (1). Hence, the correlation was used outside its designated range, and the error associated with evaluating  $h_j$  may be large.

(3) The *IHT* solver had difficulty achieving convergence in the first calculation performed for the radiation shield, since the energy balance involves two nonlinear terms due to radiation and one due to convection. To obtain a solution, a fixed value of  $Ra_L$  was prescribed for Eq. (1), while a second value of  $Ra_{L,2} \equiv g\beta(T_{s,i} - T_{s,o})L^3/\alpha\nu$  was computed from the solution. The prescribed value of  $Ra_L$  was replaced by the value of  $Ra_{L,2}$  and the calculations were repeated until  $Ra_{L,2} = Ra_L$ .

### PROBLEM 13.110

**KNOWN:** Dimensions of a composite insulation consisting of honeycomb core sandwiched between solid slabs.

**FIND:** Total thermal resistance.

**SCHEMATIC:** Because of the repetitive nature of the honeycomb core, the cell sidewalls will be adiabatic. That is, there is no lateral heat transfer from cell to cell, and it suffices to consider the heat transfer across a single cell.

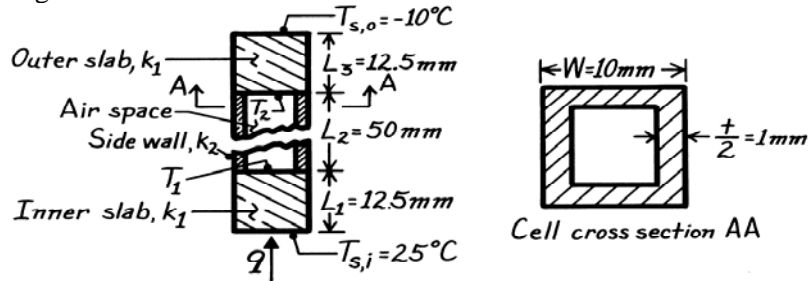

**ASSUMPTIONS:** (1) One-dimensional, steady-state conditions, (2) Equivalent conditions for each cell, (3) Constant properties, (4) Diffuse, gray surface behavior.

**PROPERTIES:** Table A-3, Particle board (low density):  $k_1 = 0.078 \text{ W/m}\cdot\text{K}$ ; Particle board (high density):  $k_2 = 0.170 \text{ W/m}\cdot\text{K}$ ; For both board materials,  $\varepsilon = 0.85$ ; Table A-4, Air ( $\bar{T} \approx 7.5^\circ\text{C}$ , 1 atm):  $\nu = 14.15 \times 10^{-6} \text{ m}^2/\text{s}$ ,  $k = 0.0247 \text{ W/m}\cdot\text{K}$ ,  $\alpha = 19.9 \times 10^{-6} \text{ m}^2/\text{s}$ ,  $\text{Pr} = 0.71$ ,  $\beta = 3.57 \times 10^{-3} \text{ K}^{-1}$ .

**ANALYSIS:** The total resistance of the composite is determined by conduction, convection and radiation processes occurring within the honeycomb and by conduction across the inner and outer slabs. The corresponding thermal circuit is shown.

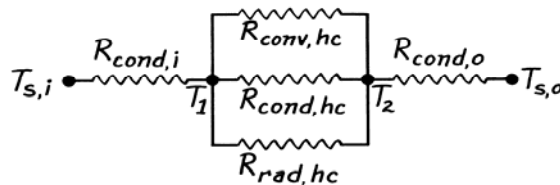

The total resistance of the composite and equivalent resistance for the honeycomb are

$$R = R_{\text{cond},i} + R_{\text{eq}} + R_{\text{cond},o} \quad R_{\text{eq}}^{-1} = \left( R_{\text{cond}}^{-1} + R_{\text{conv}}^{-1} + R_{\text{rad}}^{-1} \right)_{\text{hc}}$$

The component resistances may be evaluated as follows. The inner and outer slabs are plane walls, for which the thermal resistance is given by Eq. 3.6. Hence, since  $L_1 = L_3$  and the slabs are constructed from low-density particle board.

$$R_{\text{cond},i} = R_{\text{cond},o} = \frac{L_1}{k_1 W^2} = \frac{0.0125 \text{ m}}{0.078 \text{ W/m}\cdot\text{K} (0.01 \text{ m})^2} = 1603 \text{ K/W.}$$

Similarly, applying Eq. 3.6 to the side walls of the cell

$$\begin{aligned} R_{\text{cond},\text{hc}} &= \frac{L_2}{k_2 \left[ W^2 - (W-t)^2 \right]} = \frac{L_2}{k_2 (2Wt - t^2)} \\ &= \frac{0.050 \text{ m}}{0.170 \text{ W/m}\cdot\text{K} \left[ 2 \times 0.01 \text{ m} \times 0.002 \text{ m} - (0.002 \text{ m})^2 \right]} = 8170 \text{ K/W.} \end{aligned}$$

Continued ...

### PROBLEM 13.110 (Cont.)

From Eq. 3.9 the convection resistance associated with the cellular airspace may be expressed as

$$R_{\text{conv, hc}} = 1/h(W-t)^2.$$

The cell forms an enclosure that may be classified as a horizontal cavity heated from below, and the appropriate form of the Rayleigh number is  $Ra_L = g\beta(T_1 - T_2)L_2^3/\alpha\nu$ . To evaluate this parameter, however, it is necessary to *assume* a value of the cell temperature difference. As a first approximation,  $T_1 - T_2 = 15^\circ\text{C} - (-5^\circ\text{C}) = 20^\circ\text{C}$ ,

$$Ra_L = \frac{9.8 \text{ m/s}^2 \left(3.57 \times 10^{-3} \text{ K}^{-1}\right) (20 \text{ K}) (0.05 \text{ m})^3}{19.9 \times 10^{-6} \text{ m}^2/\text{s} \times 14.15 \times 10^{-6} \text{ m}^2/\text{s}} = 3.11 \times 10^5.$$

Applying Eq. 9.49 as a first approximation, it follows that

$$h = (k/L_2) \left[ 0.069 Ra_L^{1/3} Pr^{0.074} \right] = \frac{0.0247 \text{ W/m} \cdot \text{K}}{0.05 \text{ m}} \left[ 0.069 \left(3.11 \times 10^5\right)^{1/3} (0.71)^{0.074} \right] = 2.25 \text{ W/m}^2 \cdot \text{K}.$$

The convection resistance is then

$$R_{\text{conv, hc}} = \frac{1}{2.25 \text{ W/m}^2 \cdot \text{K} (0.01 \text{ m} - 0.002 \text{ m})^2} = 6944 \text{ K/W}.$$

The resistance to heat transfer by radiation may be obtained by first noting that the cell forms a three-surface enclosure for which the sidewalls are reradiating. The net radiation heat transfer between the end surfaces of the cell is then given by Eq. 13.30. With  $\varepsilon_1 = \varepsilon_2 = \varepsilon$  and  $A_1 = A_2 = (W-t)^2$ , the equation reduces to

$$q_{\text{rad}} = \frac{(W-t)^2 \sigma (T_1^4 - T_2^4)}{2(1/\varepsilon - 1) + \left[ F_{12} + \left[ (F_{1R} + F_{2R}) / F_{1R} F_{2R} \right] \right]^{-1}}.$$

However, with  $F_{1R} = F_{2R} = (1 - F_{12})$ , it follows that

$$q_{\text{rad}} = \frac{(W-t)^2 \sigma (T_1^4 - T_2^4)}{2\left(\frac{1}{\varepsilon} - 1\right) + \left[ F_{12} + \frac{(1 - F_{12})^2}{2(1 - F_{12})} \right]^{-1}} = \frac{(W-t)^2 \sigma (T_1^4 - T_2^4)}{2\left(\frac{1}{\varepsilon} - 1\right) + \frac{2}{1 + F_{12}}}.$$

The view factor  $F_{12}$  may be obtained from Fig. 13.4, where

$$\frac{X}{L} = \frac{Y}{L} = \frac{W-t}{L_2} = \frac{10 \text{ mm} - 2 \text{ mm}}{50 \text{ mm}} = 0.16.$$

Hence,  $F_{12} \approx 0.01$ . Defining the radiation resistance as

$$R_{\text{rad, hc}} = \frac{T_1 - T_2}{q_{\text{rad}}}$$

it follows that

Continued ...



**PROBLEM 13.110 (Cont.)**

$$R_{\text{rad,hc}} = \frac{2(1/\varepsilon - 1) + 2/(1 + F_{12})}{(W - t)^2 \sigma (T_1^2 + T_2^2)(T_1 + T_2)}$$

where  $(T_1^4 - T_2^4) = (T_1^2 + T_2^2)(T_1 + T_2)(T_1 - T_2)$ . Accordingly,

$$R_{\text{rad,hc}} = \frac{\left[ 2\left(\frac{1}{0.85} - 1\right) + \frac{2}{1 + 0.01} \right]}{(0.01 \text{ m} - 0.002 \text{ m})^2 \times 5.67 \times 10^{-8} \text{ W/m}^2 \cdot \text{K}^4 \left[ (288 \text{ K})^2 + (268 \text{ K})^2 \right] (288 + 268) \text{ K}}$$

where, again, it is *assumed* that  $T_1 = 15^\circ\text{C}$  and  $T_2 = -5^\circ\text{C}$ . From the above expression, it follows that

$$R_{\text{rad,hc}} = \frac{0.353 + 1.980}{3.123 \times 10^{-4}} = 7471 \text{ K/W}.$$

In summary the component resistances are

$$R_{\text{cond,i}} = R_{\text{cond,o}} = 1603 \text{ K/W}$$

$$R_{\text{cond,hc}} = 8170 \text{ K/W}$$

$$R_{\text{conv,hc}} = 6944 \text{ K/W}$$

$$R_{\text{rad,hc}} = 7471 \text{ K/W}.$$

The equivalent resistance is then

$$R_{\text{eq}} = \left( \frac{1}{8170} + \frac{1}{6944} + \frac{1}{7471} \right)^{-1} = 2498 \text{ K/W}$$

and the total resistance is

$$R = 1603 + 2498 + 1603 = 5704 \text{ K/W}.$$

<

**COMMENTS:** (1) The solution is iterative, since values of  $T_1$  and  $T_2$  were assumed to calculate  $R_{\text{conv,hc}}$  and  $R_{\text{rad,hc}}$ . To check the validity of the assumed values, we first obtain the heat transfer rate  $q$  from the expression

$$q = \frac{T_{s,1} - T_{s,2}}{R} = \frac{25^\circ\text{C} - (-10^\circ\text{C})}{5704 \text{ K/W}} = 6.14 \times 10^{-3} \text{ W}.$$

Hence

$$T_1 = T_{s,i} - qR_{\text{cond,i}} = 25^\circ\text{C} - 6.14 \times 10^{-3} \text{ W} \times 1603 \text{ K/W} = 15.2^\circ\text{C}$$

$$T_2 = T_{s,o} + qR_{\text{cond,o}} = -10^\circ\text{C} + 6.14 \times 10^{-3} \text{ W} \times 1603 \text{ K/W} = -0.2^\circ\text{C}.$$

Using these values of  $T_1$  and  $T_2$ ,  $R_{\text{conv,hc}}$  and  $R_{\text{rad,hc}}$  should be recomputed and the process repeated until satisfactory agreement is obtained between the initial and computed values of  $T_1$  and  $T_2$ .

(2) The resistance of a section of low density particle board 75 mm thick ( $L_1 + L_2 + L_3$ ) of area  $W^2$  is 9615 K/W, which exceeds the total resistance of the composite by approximately 70%. Accordingly, use of the honeycomb structure offers no advantages as an insulating material. Its effectiveness as an insulator could be improved ( $R_{\text{eq}}$  increased) by reducing the wall thickness  $t$  to increase  $R_{\text{cond}}$ , evacuating the cell to increase  $R_{\text{conv}}$ , and/or decreasing  $\varepsilon$  to increase  $R_{\text{rad}}$ . A significant increase in  $R_{\text{rad,hc}}$  could be achieved by aluminizing the top and bottom surfaces of the cell.

### PROBLEM 13.111

**KNOWN:** Dimensions and surface conditions of a cylindrical thermos bottle filled with hot coffee and lying horizontally.

**FIND:** Heat loss.

**SCHEMATIC:**

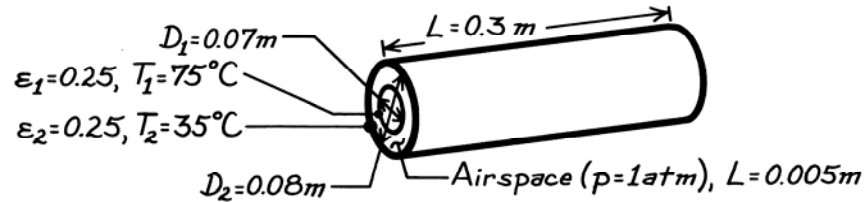

**ASSUMPTIONS:** (1) Steady-state conditions, (2) Negligible heat loss from ends (long infinite cylinders), (3) Diffuse-gray surface behavior.

**PROPERTIES:** Table A-4, Air ( $T_f = (T_1 + T_2)/2 = 328$  K, 1 atm):  $k = 0.0284$  W/m·K,  $\nu = 23.74 \times 10^{-6}$  m<sup>2</sup>/s,  $\alpha = 26.6 \times 10^{-6}$  m<sup>2</sup>/s,  $Pr = 0.703$ ,  $\beta = 3.05 \times 10^{-3}$  K<sup>-1</sup>.

**ANALYSIS:** The heat transfer across the air space is

$$q = q_{\text{rad}} + q_{\text{conv}}$$

From Eq. 13.25 for concentric cylinders

$$q_{\text{rad}} = \frac{\sigma(\pi D_1 L)(T_1^4 - T_2^4)}{\frac{1}{\epsilon_1} + \frac{1 - \epsilon_2}{\epsilon_2} \left(\frac{r_1}{r_2}\right)} = \frac{5.67 \times 10^{-8} \text{ W/m}^2 \cdot \text{K}^4 \pi (0.07 \times 0.3) \text{ m}^2 (348^4 - 308^4) \text{ K}^4}{4 + 3(0.035/0.04)}$$

$$q_{\text{rad}} = 3.20 \text{ W}$$

The convection heat rate is given by Eqs. 9.58 through 9.60. The length scale is  $L_c = 2[\ln(0.08/0.07)]^{4/3}/(0.035 \text{ m}^{-3/5} + 0.040 \text{ m}^{-3/5})^{5/3} = 0.0016$  m. The Rayleigh number is

$$Ra_c = \frac{g\beta(T_1 - T_2)L_c^3}{\nu\alpha} = \frac{9.8 \text{ m/s}^2 (3.05 \times 10^{-3} \text{ K}^{-1})(40 \text{ K})(0.0016 \text{ m})^3}{26.6 \times 10^{-6} \text{ m}^2/\text{s} \times 23.74 \times 10^{-6} \text{ m}^2/\text{s}} = 7.85$$

From Eq. 9.59,

$$k_{\text{eff}}/k = 0.386 \left( \frac{Pr}{0.861 + Pr} \right)^{1/4} Ra_c^{1/4} = 0.386 \left( \frac{0.703}{0.861 + 0.703} \right)^{1/4} 7.85^{1/4} = 0.529$$

Since  $k_{\text{eff}}/k$  is predicted to be less than unity, conduction occurs in the gap. From Eq. 3.32

$$q_{\text{cond}} = \frac{2\pi Lk(T_1 - T_2)}{\ln(r_2/r_1)} = \frac{2\pi \times 0.3 \text{ m} \times 0.0284 \text{ W/m} \cdot \text{K} (75 - 35) \text{ K}}{\ln(0.04/0.035)} = 16.04 \text{ W}$$

Hence the total heat loss is

$$q = q_{\text{rad}} + q_{\text{cond}} = 19.24 \text{ W}$$

<

**COMMENTS:** (1) End effects could be considered in a more detailed analysis, (2) Conduction losses could be eliminated by evacuating the annulus.

### PROBLEM 13.112

**KNOWN:** Temperatures and emissivity of window panes and critical Rayleigh number for onset of convection in air space.

**FIND:** (a) The conduction heat flux across the air gap for the optimal spacing, (b) The total heat flux for uncoated panes, (c) The total heat flux if one or both of the panes has a low-emissivity coating.

**SCHEMATIC:**

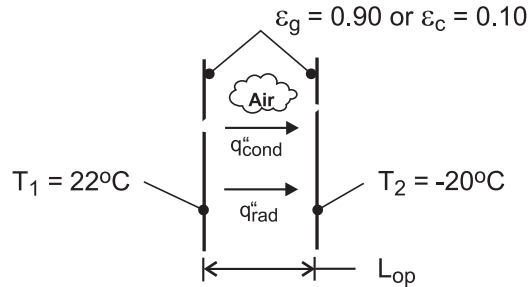

**ASSUMPTIONS:** (1) Critical Rayleigh number is  $Ra_{L,c} = 2000$ , (2) Constant properties, (3) Radiation exchange between large (infinite), parallel, diffuse-gray surfaces.

**PROPERTIES:** Table A-4, air [ $T = (T_1 + T_2)/2 = 1^\circ\text{C} = 274\text{ K}$ ]:  $\nu = 13.6 \times 10^{-6}\text{ m}^2/\text{s}$ ,  $k = 0.0242\text{ W/m}\cdot\text{K}$ ,  $\alpha = 19.1 \times 10^{-6}\text{ m}^2/\text{s}$ ,  $\beta = 0.00365\text{ K}^{-1}$ .

**ANALYSIS:** (a) With  $Ra_{L,c} = g\beta(T_1 - T_2)L_{op}^3 / \alpha\nu$

$$L_{op} = \left[ \frac{\alpha\nu Ra_{L,c}}{g\beta(T_1 - T_2)} \right]^{1/3} = \left[ \frac{19.1 \times 13.6 \times 10^{-12}\text{ m}^4/\text{s}^2 \times 2000}{9.8\text{ m/s}^2 (0.00365\text{ K}^{-1}) 42^\circ\text{C}} \right]^{1/3} = 0.0070\text{ m}$$

The conduction heat flux is then

$$q''_{cond} = k(T_1 - T_2)/L_{op} = 0.0242\text{ W/m}\cdot\text{K}(42^\circ\text{C})/0.0070\text{ m} = 145.2\text{ W/m}^2 <$$

(b) For conventional glass ( $\varepsilon_g = 0.90$ ), Eq. 13.24 yields,

$$q''_{rad} = \frac{\sigma(T_1^4 - T_2^4)}{\frac{2}{\varepsilon_g} - 1} = \frac{5.67 \times 10^{-8}\text{ W/m}^2 \cdot \text{K}^4 (295^4 - 253^4)\text{ K}^4}{1.222} = 161.3\text{ W/m}^2$$

and the total heat flux is

$$q''_{tot} = q''_{cond} + q''_{rad} = 306.5\text{ W/m}^2 <$$

(c) With only one surface coated,

$$q''_{rad} = \frac{5.67 \times 10^{-8}\text{ W/m}^2 \cdot \text{K}^4 (295^4 - 253^4)}{\frac{1}{0.90} + \frac{1}{0.10} - 1} = 19.5\text{ W/m}^2$$

Continued ...

**PROBLEM 13.112 (Cont.)**

$$q''_{\text{tot}} = 164.7 \text{ W/m}^2$$

<

With both surfaces coated,

$$q''_{\text{rad}} = \frac{5.67 \times 10^{-8} \text{ W/m}^2 \cdot \text{K}^4 (295^4 - 253^4)}{\frac{1}{0.10} + \frac{1}{0.10} - 1} = 10.4 \text{ W/m}^2$$

$$q''_{\text{tot}} = 155.6 \text{ W/m}^2$$

<

**COMMENTS:** Without any coating, radiation makes a large contribution (53%) to the total heat loss. With one coated pane, there is a significant reduction (46%) in the total heat loss. However, the benefit of coating both panes is marginal, with only an additional 3% reduction in the total heat loss.

### PROBLEM 13.113

**KNOWN:** Dimensions and emissivity of double pane window. Thickness of air gap. Temperatures of room and ambient air and the related surroundings.

**FIND:** (a) Temperatures of glass panes and rate of heat transfer through window, (b) Heat rate if gap is evacuated. Heat rate if special coating is applied to window.

**SCHEMATIC:**

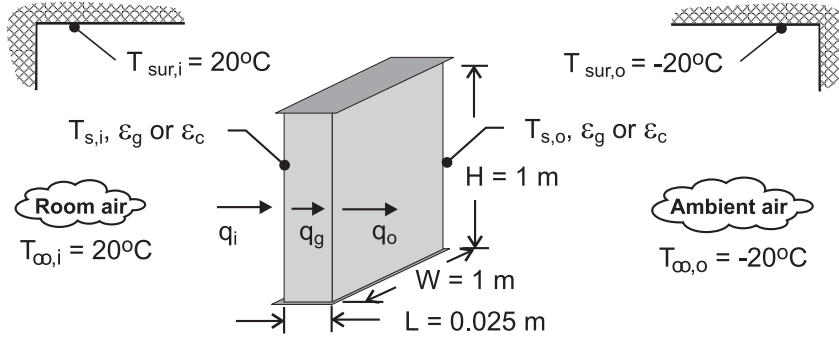

**ASSUMPTIONS:** (1) Steady-state, (2) Negligible glass pane thermal resistance, (3) Constant properties, (4) Diffuse-gray surface behavior, (5) Radiation exchange between interior window surfaces may be approximated as exchange between infinite parallel plates, (6) Interior and exterior surroundings are very large.

**PROPERTIES:** Table A-4, Air ( $p = 1$  atm). Obtained from using *IHT* to solve for conditions of Part (a):  $T_{f,i} = 287.4$  K:  $\nu_i = 14.8 \times 10^{-6}$  m<sup>2</sup>/s,  $k_i = 0.0253$  W/m·K,  $\alpha_i = 20.8 \times 10^{-6}$  m<sup>2</sup>/s,  $Pr_i = 0.71$ ,  $\beta_i = 0.00348$  K<sup>-1</sup>.  $\bar{T} = (T_{s,i} + T_{s,o})/2 = 273.7$  K:  $\nu = 13.6 \times 10^{-6}$  m<sup>2</sup>/s,  $k = 0.0242$  W/m·K,  $\alpha = 19.0 \times 10^{-6}$  m<sup>2</sup>/s,  $Pr = 0.71$ ,  $\beta = 0.00365$  K<sup>-1</sup>.  $T_{f,o} = 259.3$  K:  $\nu_o = 12.3 \times 10^{-6}$  m<sup>2</sup>/s,  $k_o = 0.023$  W/m·K,  $\alpha_o = 17.1 \times 10^{-6}$  m<sup>2</sup>/s,  $Pr_o = 0.72$ ,  $\beta_o = 0.00386$  K<sup>-1</sup>.

**ANALYSIS:** (a) The heat flux through the window may be expressed as

$$q'' = q''_{\text{rad},i} + q''_{\text{conv},i} = \epsilon_g \sigma (T_{\text{sur},i}^4 - T_{s,i}^4) + \bar{h}_i (T_{\infty,i} - T_{s,i}) \quad (1)$$

$$q'' = q''_{\text{rad},\text{gap}} + q''_{\text{conv},\text{gap}} = \frac{\sigma (T_{s,i}^4 - T_{s,o}^4)}{\frac{1}{\epsilon_g} + \frac{1}{\epsilon_g} - 1} + \bar{h}_{\text{gap}} (T_{s,i} - T_{s,o}) \quad (2)$$

$$q'' = q''_{\text{rad},o} + q''_{\text{conv},o} = \epsilon_g \sigma (T_{s,o}^4 - T_{\text{sur},o}^4) + \bar{h}_o (T_{s,o} - T_{\infty,o}) \quad (3)$$

where radiation exchange between the window panes is determined from Eq. 13.24. The inner and outer convection coefficients,  $\bar{h}_i$  and  $\bar{h}_o$ , are determined from Eq. 9.26, and  $\bar{h}_{\text{gap}}$  is obtained from Eq. 9.52.

The foregoing equations may be solved for the three unknowns ( $q''$ ,  $T_{s,i}$ ,  $T_{s,o}$ ). Using the *IHT* software to effect the solution, we obtain

$$T_{s,i} = 281.8 \text{ K} = 8.8^\circ\text{C}$$

<

Continued ...

**PROBLEM 13.113 (Cont.)**

$$T_{s,o} = 265.6 \text{ K} = -7.4^\circ\text{C} \quad <$$

$$q = 91.3 \text{ W} \quad <$$

(b) If the air space is evacuated ( $\bar{h}_g = 0$ ), we obtain

$$T_{s,i} = 283.6 \text{ K} = 10.6^\circ\text{C} \quad <$$

$$T_{s,o} = 263.8 \text{ K} = 9.2^\circ\text{C} \quad <$$

$$q = 75.5 \text{ W} \quad <$$

If the space is not evacuated but the coating is applied to inner surfaces of the window panes,

$$T_{s,i} = 285.9 \text{ K} = 12.9^\circ\text{C} \quad <$$

$$T_{s,o} = 261.3 \text{ K} = -11.7^\circ\text{C} \quad <$$

$$q = 55.9 \text{ W} \quad <$$

If the space is evacuated and the coating is applied,

$$T_{s,i} = 291.7 \text{ K} = 18.7^\circ\text{C} \quad <$$

$$T_{s,o} = 254.7 \text{ K} = -18.3^\circ\text{C} \quad <$$

$$q = 9.0 \text{ W} \quad <$$

**COMMENTS:** (1) For the conditions of part (a), the convection and radiation heat fluxes are comparable at the inner and outer surfaces of the window, but because of the comparatively small convection coefficient, the radiation flux is approximately twice the convection flux across the air gap. (2) As the resistance across the air gap is progressively increased (evacuated, coated, evacuated and coated), the temperatures of the inner and outer panes increase and decrease, respectively, and the heat loss decreases. (3) Clearly, there are significant energy savings associated with evacuation of the gap and application of the coating. (4) In all cases, solutions were obtained using the temperature-dependent properties of air provided by the software. The property values listed in the **PROPERTIES** section of this solution pertain to the conditions of part (a).

### PROBLEM 13.114

**KNOWN:** Absorber and cover plate temperatures and spectral absorptivities for a flat plate solar collector. Collector orientation and solar flux.

**FIND:** (a) Rate of solar radiation absorption per unit area, (b) Heat loss per unit area.

**SCHEMATIC:**

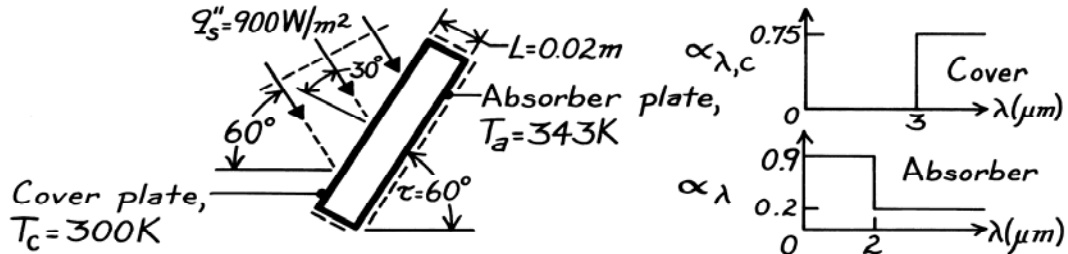

**ASSUMPTIONS:** (1) Steady-state conditions, (2) Adiabatic sides and bottom, (3) Cover is transparent to solar radiation, (4) Sun emits as a blackbody at 5800 K, (5) Cover and absorber plates are diffuse-gray to long wave radiation, (6) Negligible end effects, (7)  $L \ll$  width and length.

**PROPERTIES:** Table A-4, Air ( $T = T_a + T_c$ )/2 = 321.5 K, 1 atm):  $\nu = 18.05 \times 10^{-6} \text{ m}^2/\text{s}$ ,  $k = 0.0279 \text{ W/m}\cdot\text{K}$ ,  $\alpha = 25.7 \times 10^{-6} \text{ m}^2/\text{s}$ .

**ANALYSIS:** (a) The absorbed solar irradiation is

$$G_{S,\text{abs}} = \alpha_{S,a} G_S$$

where

$$G_S = q_s'' \cos 30^\circ = 900 \times 0.866 = 779.4 \text{ W/m}^2$$

$$\alpha_{S,a} = \frac{\int_0^\infty \alpha_{\lambda,a} G_{\lambda,S} d\lambda}{G_S} = \frac{\int_0^\infty \alpha_{\lambda,a} E_{\lambda,b}(5800 \text{ K}) d\lambda}{E_b(5800 \text{ K})}$$

$$\alpha_{S,a} = \alpha_{\lambda,a,1} F_{(0 \rightarrow 2 \mu\text{m})} + \alpha_{\lambda,a,2} F_{(2 \rightarrow \infty)}$$

For  $\lambda T = 2 \mu\text{m} \times 5800 \text{ K} = 11,600 \mu\text{m}\cdot\text{K}$  from Table 12.1,  $F_{(0 \rightarrow 2\lambda T)} = 0.941$ , find

$$\alpha_{S,a} = 0.9 \times 0.941 + 0.2 \times (1 - 0.941) = 0.859.$$

Hence

$$G_{S,\text{abs}} = 0.859 \times 779.4 = 669 \text{ W/m}^2. \quad \leftarrow$$

(b) The heat loss per unit area from the collector is

$$q_{\text{loss}}'' = q_{\text{conv}}'' + q_{\text{rad}}''$$

The convection heat flux is

$$q_{\text{conv}}'' = \bar{h} (T_a - T_c)$$

Continued ...

**PROBLEM 13.114 (Cont.)**

and with

$$\text{Ra}_L = \frac{g\beta(T_a - T_c)L^3}{\alpha\nu}$$

$$\text{Ra}_L = \frac{9.8 \text{ m/s}^2 \times (321.5 \text{ K})^{-1} (343 - 300) \text{ K} (0.02 \text{ m})^3}{18.05 \times 10^{-6} \text{ m}^2/\text{s} \times 25.7 \times 10^{-6} \text{ m}^2/\text{s}} = 22,604$$

find from Eq. 9.54 with

$$H/L > 12, \tau < \tau^*, \cos \tau = 0.5, \text{Ra}_L \cos \tau = 11,302$$

$$\overline{\text{Nu}}_L = 1 + 1.44 \left[ 1 - \frac{1708}{11,302} \right] \left[ 1 - \frac{1708(\sin 108^\circ)^{1.6}}{11,302} \right] + \left[ \left( \frac{11,302}{5830} \right)^{1/3} - 1 \right]$$

$$\bar{h} = \overline{\text{Nu}}_L \frac{k}{L} = 2.30 \times \frac{0.0279 \text{ W/m} \cdot \text{K}}{0.02 \text{ m}} = 3.21 \text{ W/m}^2 \cdot \text{K}.$$

Hence, the convective heat flux is

$$q''_{\text{conv}} = 3.21 \text{ W/m}^2 \cdot \text{K} (343 - 300) \text{ K} = 138.0 \text{ W/m}^2.$$

The radiative exchange can be determined from Eq. 13.24 treating the cover and absorber plates as a two-surface enclosure,

$$q''_{\text{rad}} = \frac{\sigma(T_a^4 - T_c^4)}{1/\epsilon_a + 1/\epsilon_c - 1} = \frac{5.67 \times 10^{-8} \text{ W/m}^2 \cdot \text{K}^4 \left[ (343 \text{ K})^4 - (300 \text{ K})^4 \right]}{1/0.2 + 1/0.75 - 1}$$

$$q''_{\text{rad}} = 61.1 \text{ W/m}^2.$$

Hence, the total heat loss per unit area from the collector

$$q''_{\text{loss}} = (138.0 + 61.1) = 199 \text{ W/m}^2. \quad \leftarrow$$

**COMMENTS:** (1) Non-solar components of radiation transfer are concentrated at long wavelength for which  $\alpha_a = \epsilon_a = 0.2$  and  $\alpha_c = \epsilon_c = 0.75$ .

(2) The collector efficiency is

$$\eta = \frac{669.3 - 199.1}{669.3} \times 100 = 70\%.$$

This value is uncharacteristically high due to specification of nearly optimum  $\alpha_a(\lambda)$  for absorber.



### PROBLEM 13.115

**KNOWN:** Diameters and temperatures of a heated tube and a radiation shield.

**FIND:** (a) Total heat loss per unit length of tube, (b) Effect of shield diameter on heat rate.

**SCHEMATIC:**

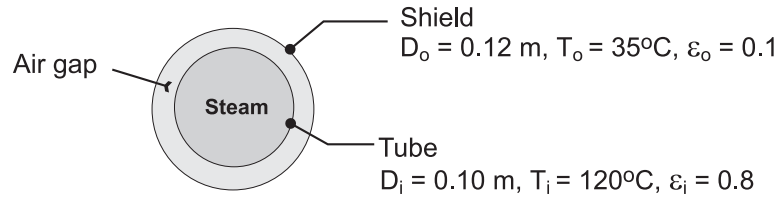

**ASSUMPTIONS:** (1) Opaque, diffuse-gray surfaces, (2) Negligible end effects.

**PROPERTIES:** Table A-4, Air ( $T_f = 77.5^\circ\text{C} \approx 350 \text{ K}$ ):  $k = 0.030 \text{ W/m}\cdot\text{K}$ ,  $\text{Pr} = 0.70$ ,  $\nu = 20.92 \times 10^{-6} \text{ m}^2/\text{s}$ ,  $\alpha = 29.9 \times 10^{-6} \text{ m}^2/\text{s}$ ,  $\beta = 0.00286 \text{ K}^{-1}$ .

**ANALYSIS:** (a) Heat loss from the tube is by radiation and free convection

$$q' = q'_{\text{rad}} + q'_{\text{conv}}$$

From Eq. 13.25

$$q'_{\text{rad}} = \frac{\sigma(\pi D_i)(T_i^4 - T_o^4)}{\frac{1}{\epsilon_i} + \frac{1 - \epsilon_o}{\epsilon_o} \left(\frac{r_i}{r_o}\right)}$$

or

$$q'_{\text{rad}} = \frac{5.67 \times 10^{-8} \frac{\text{W}}{\text{m}^2 \cdot \text{K}^4} (\pi \times 0.1 \text{ m}) (393^4 - 308^4) \text{ K}^4}{\frac{1}{0.8} + \frac{0.9}{0.1} \left(\frac{0.05}{0.06}\right)} = 30.2 \frac{\text{W}}{\text{m}}$$

The convection heat rate is given by Eqs. 9.58 through 9.60. The length scale is  $L_c = 2[\ln(0.12/0.10)]^{4/3}/(0.05 \text{ m}^{-3/5} + 0.05 \text{ m}^{-3/5})^{5/3} = 0.0036 \text{ m}$ . The Rayleigh number is  $\text{Ra}_c = g\beta(T_i - T_o)L_c^3/\nu\alpha = 9.8 \text{ m/s}^2(0.00286 \text{ K}^{-1})(120 - 35) \text{ K}(0.0036 \text{ m})^3/(20.92 \times 10^{-6} \text{ m}^2/\text{s} \times 29.9 \times 10^{-6} \text{ m}^2/\text{s}) = 171.6$ . Also,  $k_{\text{eff}}/k = 0.386 \times [0.700/(0.861 + 0.700)]^{1/4}(171.6)^{1/4} = 1.14$ . Therefore,  $k_{\text{eff}} = 1.14 \times 0.030 \text{ W/m}\cdot\text{K} = 0.0343 \text{ W/m}\cdot\text{K}$ . From Eq. 9.58,

$$q'_{\text{conv}} \frac{2\pi k_{\text{eff}}(T_i - T_o)}{\ln(D_i/D_o)} = \frac{2 \times \pi \times 0.0343 \text{ W/m}\cdot\text{K} \times (120 - 35) \text{ K}}{\ln(0.12/0.10)} = 100.5 \text{ W/m}$$

$$q' = (30.2 + 100.5) \frac{\text{W}}{\text{m}} = 130.7 \frac{\text{W}}{\text{m}}$$

Continued...

### PROBLEM 13.115 (Cont.)

(b) As shown below, both convection and radiation, and hence the total heat rate, increase with increasing shield diameter. In the limit as  $D_o \rightarrow \infty$ , the radiation rate approaches that corresponding to net transfer between a small surface and large surroundings at  $T_o$ . The rate is independent of  $\varepsilon$ .

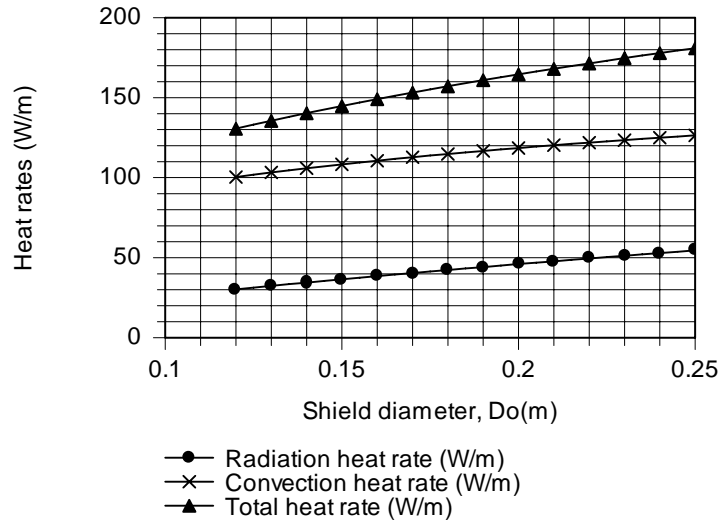

**COMMENTS:** Designation of a shield temperature is arbitrary. The temperature depends on the nature of the environment external to the shield.

### PROBLEM 13.116

**KNOWN:** Diameters of heated tube and radiation shield. Tube surface temperature and temperature of ambient air and surroundings.

**FIND:** Temperature of radiation shield and heat loss per unit length of tube.

**SCHEMATIC:**

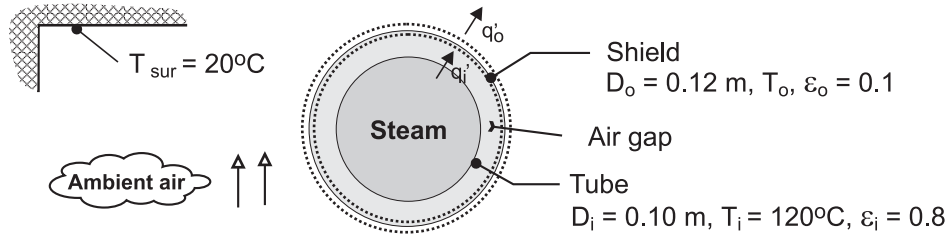

**ASSUMPTIONS:** (1) Opaque, diffuse-gray surfaces, (2) Negligible end effects, (3) Large surroundings, (4) Quiescent air, (5) Steady-state.

**PROPERTIES:** Determined from use of *IHT* software for iterative solution. Air,  $(T_i + T_o)/2 = 362.7$  K:  $\nu_i = 2.23 \times 10^{-5} \text{ m}^2/\text{s}$ ,  $k_i = 0.031 \text{ W/m}\cdot\text{K}$ ,  $\alpha_i = 3.20 \times 10^{-5} \text{ m}^2/\text{s}$ ,  $\beta_i = 0.00276 \text{ K}^{-1}$ ,  $\text{Pr}_i = 0.698$ . Air,  $T_f = 312.7$  K:  $\nu_o = 1.72 \times 10^{-5} \text{ m}^2/\text{s}$ ,  $k_o = 0.027 \text{ W/m}\cdot\text{K}$ ,  $\alpha_o = 2.44 \times 10^{-5} \text{ m}^2/\text{s}$ ,  $\beta_o = 0.0032 \text{ K}^{-1}$ ,  $\text{Pr}_o = 0.705$ .

**ANALYSIS:** From an energy balance on the radiation shield,  $q'_i = q'_o$  or  $q'_{\text{rad},i} + q'_{\text{conv},i} = q'_{\text{rad},o} + q'_{\text{conv},o}$ . Evaluating the inner and outer radiation rates from Eqs. 13.25 and 13.27, respectively, and the convection heat rate in the air gap from Eq. 9.58,

$$\frac{\sigma \pi D_i (T_i^4 - T_o^4)}{\frac{1}{\varepsilon_i} + \frac{1 - \varepsilon_o}{\varepsilon_o} \left( \frac{D_i}{D_o} \right)} + \frac{2\pi k_{\text{eff}} (T_i - T_o)}{\ln(D_o/D_i)} = \sigma \pi D_o \varepsilon_o (T_o^4 - T_{\text{sur}}^4) + \pi D_o \bar{h}_o (T_o - T_\infty)$$

The convection heat rate is given by Eqs. 9.58 through 9.60. The length scale is  $L_c = 2[\ln(0.12/0.10)]^{4/3}/(0.05 \text{ m}^{-3/5} + 0.05 \text{ m}^{-3/5})^{5/3} = 0.0036 \text{ m}$ . The Rayleigh number is  $\text{Ra}_c = g\beta_i(T_i - T_o)L_c^3/\nu_i\alpha_i = 9.8 \text{ m/s}^2(0.00276 \text{ K}^{-1})(120 - T_o) \text{ K} (0.0036 \text{ m})^3/(22.3 \times 10^{-6} \text{ m}^2/\text{s} \times 32.0 \times 10^{-6} \text{ m}^2/\text{s})$ . Also,  $k_{\text{eff}}/k = 0.386 \times k_i \times [\text{Pr}_i/(0.861 + \text{Pr}_i)]^{1/4}(\text{Ra}_c)^{1/4} = 1.14$ . From Eq. 9.34, the convection coefficient on the outer surface of the shield is

$$\bar{h}_o = \frac{k_o}{D_o} \left\{ 0.60 + \frac{0.387 \text{ Ra}_D^{1/6}}{\left[ 1 + (0.559/\text{Pr}_o)^{9/16} \right]^{8/27}} \right\}^2$$

The solution to the energy balance is obtained using the *IHT* software, and the result is

$$T_o = 332.5 \text{ K} = 59.5^\circ\text{C} \quad <$$

The corresponding value of the heat loss is

$$q'_i = 88.7 \text{ W/m} \quad <$$

Continued...

### PROBLEM 13.116 (Cont.)

**COMMENTS:** (1) The radiation and convection heat rates are  $q'_{\text{rad},i} = 23.7 \text{ W/m}$ ,  $q'_{\text{rad},o} = 10.4 \text{ W/m}$ ,  $q'_{\text{conv},i} = 65.0 \text{ W/m}$ , and  $q'_{\text{conv},o} = 78.3 \text{ W/m}$ . Convection is clearly the dominant mode of heat transfer. (2) With a value of  $T_o = 59.5^\circ\text{C} > 35^\circ\text{C}$ , the heat loss is reduced (88.7 W/m compared to 130.7 W/m if the shield is at  $35^\circ\text{C}$ ).

### PROBLEM 13.117

**KNOWN:** Dimensions and inclination angle of a flat-plate solar collector. Absorber and cover plate temperatures and emissivities.

**FIND:** (a) Rate of heat transfer by free convection and radiation, (b) Effect of the absorber plate temperature on the heat rates.

**SCHEMATIC:**

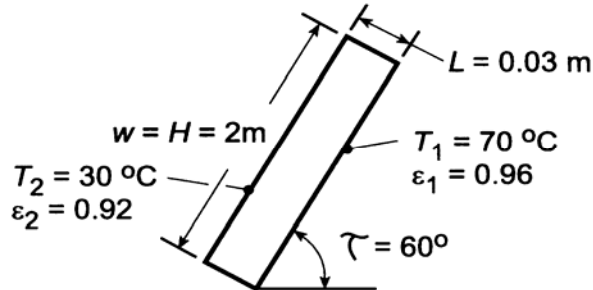

**ASSUMPTIONS:** (1) Diffuse-gray, opaque surface behavior.

**PROPERTIES:** Table A-4, air ( $\bar{T} = (T_1 + T_2)/2 = 323 \text{ K}$ ):  $\nu = 18.2 \times 10^{-6} \text{ m}^2/\text{s}$ ,  $k = 0.028 \text{ W/m}\cdot\text{K}$ ,  $\alpha = 25.9 \times 10^{-6} \text{ m}^2/\text{s}$ ,  $\text{Pr} = 0.704$ ,  $\beta = 0.0031 \text{ K}^{-1}$ .

**ANALYSIS:** (a) The convection heat rate is

$$q_{\text{conv}} = \bar{h}A(T_1 - T_2)$$

where  $A = wH = 4 \text{ m}^2$  and, with  $H/L > 12$  and  $\tau < \tau^* = 70 \text{ deg}$ ,  $\bar{h}$  is given by Eq. 9.54. With a Rayleigh number of

$$\text{Ra}_L = \frac{g\beta(T_1 - T_2)L^3}{\alpha\nu} = \frac{9.8 \text{ m/s}^2 (0.0031 \text{ K}^{-1})(40^\circ\text{C})(0.03 \text{ m})^3}{25.9 \times 10^{-6} \text{ m}^2/\text{s} \times 18.2 \times 10^{-6} \text{ m}^2/\text{s}} = 69,600$$

$$\overline{\text{Nu}}_L = 1 + 1.44 \left[ 1 - \frac{1708}{0.5(69,600)} \right] \left[ 1 - \frac{1708(0.923)}{0.5(69,600)} \right] + \left[ \left( \frac{0.5 \times 69,600}{5830} \right)^{1/3} - 1 \right]$$

$$\overline{\text{Nu}}_L = 1 + 1.44[0.951][0.955] + 0.814 = 3.12$$

$$\bar{h} = (k/L)\overline{\text{Nu}}_L = (0.028 \text{ W/m}\cdot\text{K}/0.03 \text{ m})3.12 = 2.91 \text{ W/m}^2\cdot\text{K}$$

$$q_{\text{conv}} = 2.91 \text{ W/m}^2\cdot\text{K} (4 \text{ m}^2)(70 - 30)^\circ\text{C} = 466 \text{ W} \quad <$$

The net rate of radiation exchange is given by Eq. 13.24.

$$q = \frac{A\sigma(T_1^4 - T_2^4)}{\frac{1}{\epsilon_1} + \frac{1}{\epsilon_2} - 1} = \frac{(4 \text{ m}^2)5.67 \times 10^{-8} \text{ W/m}^2\cdot\text{K}^4(343^4 - 303^4)}{\frac{1}{0.96} + \frac{1}{0.92} - 1} = 1088 \text{ W} \quad <$$

(b) The effect of the absorber plate temperature was determined by entering Eq. 9.54 into the *IHT* workspace and using the *Properties* and *Radiation* Toolpads.

Continued ...

### PROBLEM 13.117 (Cont.)

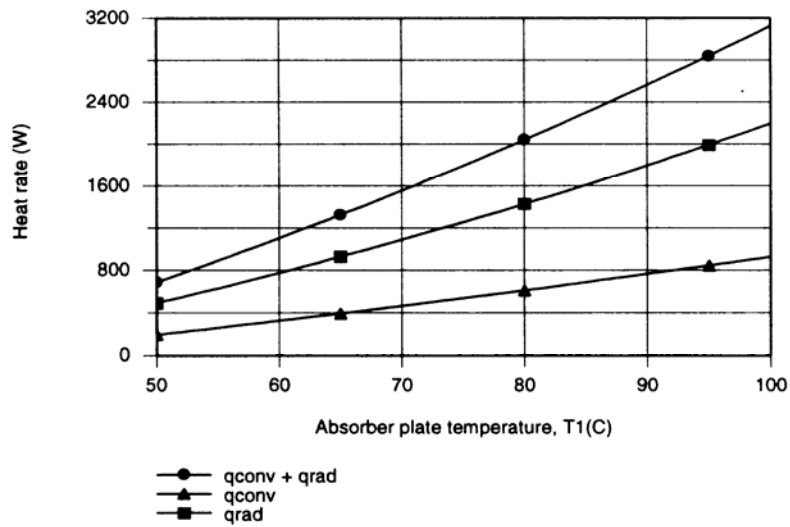

As expected, the convection and radiation losses increase with increasing  $T_1$ , with the  $T^4$  dependence providing a more pronounced increase for the radiation.

**COMMENTS:** To minimize heat losses, it is obviously desirable to operate the absorber plate at the lowest possible temperature. However, requirements for the outlet temperature of the working fluid may dictate operation at a low flow rate and hence an elevated plate temperature.

## PROBLEM 13.118

**KNOWN:** Disk heated by an electric furnace on its lower surface and exposed to an environment on its upper surface.

**FIND:** (a) Net heat transfer to (or from) the disk  $q_{\text{net,d}}$  when  $T_d = 400$  K and (b) Compute and plot  $q_{\text{net,d}}$  as a function of disk temperature for the range  $300 \leq T_d \leq 500$  K; determine steady-state temperature of the disk.

**SCHEMATIC:**

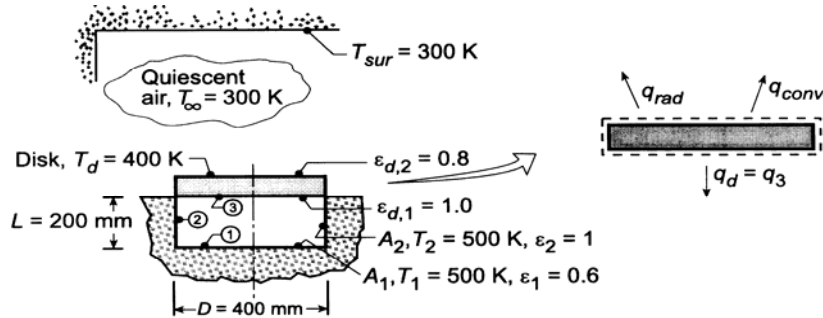

**ASSUMPTIONS:** (1) Steady-state conditions, (2) Disk is isothermal; negligible thermal resistance, (3) Surroundings are isothermal and large compared to the disk, (4) Non-black surfaces are gray-diffuse, (5) Furnace-disk forms a 3-surface enclosure, (6) Negligible convection in furnace, (7) Ambient air is quiescent.

**PROPERTIES:** Table A-4, Air ( $T_f = (T_d + T_\infty)/2 = 350$  K, 1 atm):  $\nu = 20.92 \times 10^{-6} \text{ m}^2/\text{s}$ ,  $k = 0.30 \text{ W/m}\cdot\text{K}$ ,  $\alpha = 29.9 \times 10^{-6} \text{ m}^2/\text{s}$ .

**ANALYSIS:** (a) Perform an energy balance on the disk identifying:  $q_{\text{rad}}$  as the net radiation exchange between the disk and surroundings;  $q_{\text{conv}}$  as the convection heat transfer; and  $q_3$  as the net radiation leaving the disk within the 3-surface enclosure.

$$q_{\text{net,d}} = \dot{E}_{\text{in}} - \dot{E}_{\text{out}} = -q_{\text{rad}} - q_{\text{conv}} - q_3 \quad (1)$$

*Radiation exchange with surroundings:* The rate equation is of the form

$$q_{\text{rad}} = \varepsilon_{d,2} A_d \sigma (T_d^4 - T_{\text{sur}}^4) \quad (2)$$

$$q_{\text{rad}} = 0.8 (\pi/4) (0.400 \text{ m})^2 5.67 \times 10^{-8} \text{ W/m}^2 \cdot \text{K}^4 (400^4 - 300^4) \text{ K}^4 = 99.8 \text{ W}.$$

*Free convection:* The rate equation is of the form

$$q_{\text{conv}} = \bar{h} A_d (T_d - T_\infty) \quad (3)$$

where  $\bar{h}$  can be estimated by an appropriate convection correlation. Find first,

$$\text{Ra}_L = g \beta \Delta T L^3 / \nu \alpha \quad (4)$$

$$\text{Ra}_L = 9.8 \text{ m/s}^2 (1/350 \text{ K}) (400 - 300) \text{ K} (0.400 \text{ m}/4)^3 / 20.92 \times 10^{-6} \text{ m}^2/\text{s}^2 \times 29.9 \times 10^{-6} \text{ m}^2/\text{s}$$

$$\text{Ra}_L = 4.476 \times 10^6$$

where  $L = A_c/P = D/4$ . For the upper surface of a heated plate for which  $10^4 \leq \text{Ra}_L \leq 10^7$ , Eq. 9.30 is the appropriate correlation,

Continued ...

**PROBLEM 13.118 (Cont.)**

$$\overline{\text{Nu}}_L = \overline{h}L/k = 0.54 \text{Ra}_L^{1/4} \quad (5)$$

$$\overline{h} = 0.030 \text{ W/m} \cdot \text{K} / (0.400 \text{ m} / 4) \times 0.54 \left( 4.476 \times 10^6 \right)^{1/4} = 7.45 \text{ W/m}^2 \cdot \text{K}$$

Hence, from Eq. (3),

$$q_{\text{conv}} = 7.45 \text{ W/m}^2 \cdot \text{K} (\pi/4) (0.400 \text{ m})^2 (400 - 300) \text{ K} = 93.6 \text{ W}.$$

*Furnace-disk enclosure:* From Eq. 13.20, the net radiation leaving the disk is

$$q_3 = \frac{J_3 - J_1}{(A_3 F_{31})^{-1}} + \frac{J_3 - J_2}{(A_3 F_{32})^{-1}} = A_3 [F_{31} (J_3 - J_1) + F_{32} (J_3 - J_2)]. \quad (6)$$

The view factor  $F_{32}$  can be evaluated from the *coaxial parallel disks* relation of Table 13.1 or from Fig. 13.5.

$$R_i = r_i / L = 200 \text{ mm} / 200 \text{ mm} = 1,$$

$$R_j = r_j / L = 1,$$

$$S = 1 + \left( 1 + R_j^2 \right) / R_i^2 = 1 + \left( 1 + 1^2 \right) 1^2 = 3$$

$$F_{31} = 1/2 \left\{ S - \left[ S^2 - 4 \left( r_j / r_i \right)^2 \right]^{1/2} \right\} = 1/2 \left\{ 3 - \left[ 3^2 - 4(1)^2 \right]^{1/2} \right\} = 0.382. \quad (7)$$

From summation rule,  $F_{32} = 1 - F_{33} - F_{31} = 0.618$  with  $F_{33} = 0$ . Since surfaces  $A_2$  and  $A_3$  are black,

$$J_2 = E_{b2} = \sigma T_2^4 = \sigma (500 \text{ K})^4 = 3544 \text{ W/m}^2$$

$$J_3 = E_{b3} = \sigma T_3^4 = \sigma (400 \text{ K})^4 = 1452 \text{ W/m}^2.$$

To determine  $J_1$ , use Eq. 13.21, the radiation balance equation for  $A_1$ , noting that  $F_{12} = F_{32}$  and  $F_{13} = F_{31}$ ,

$$\begin{aligned} \frac{E_{b1} - J_1}{(1 - \varepsilon_1) / \varepsilon_1 A_1} &= \frac{J_1 - J_2}{(A_1 F_{12})^{-1}} + \frac{J_1 - J_3}{(A_1 F_{13})^{-1}} \\ \frac{3544 - J_1}{(1 - 0.6) / 0.6} &= \frac{J_1 - 3544}{(0.618)^{-1}} + \frac{J_1 - 1452}{(0.382)^{-1}} \quad J_1 = 3226 \text{ W/m}^2. \end{aligned} \quad (8)$$

Substituting numerical values in Eq. (6), find

$$q_3 = (\pi/4) (0.400 \text{ m})^2 \left[ 0.382 (1452 - 3226) \text{ W/m}^2 + 0.618 (1452 - 3544) \text{ W/m}^2 \right] = -248 \text{ W}.$$

Returning to the overall energy balance, Eq. (1), the net heat transfer to the disk is

$$q_{\text{net,d}} = -99.8 \text{ W} - 93.6 \text{ W} - (-248 \text{ W}) = +54.6 \text{ W} \quad <$$

That is, there is a net heat transfer rate *into* the disk.

(b) Using the energy balance, Eq. (1), and the rate equation, Eqs. (2) and (3) with the *IHT Radiation Tool, Radiation, Exchange Analysis, Radiation surface energy balances* and the *Correlation Tool, Free Convection, Horizontal Plate (Hot surface up)*, the analysis was performed to obtain  $q_{\text{net,d}}$  as a function of  $T_d$ . The results are plotted below.

The steady-state condition occurs when  $q_{\text{net,d}} = 0$  for which

$$T_d = 413 \text{ K} \quad <$$

Continued ...



## PROBLEM 13.118 (Cont.)

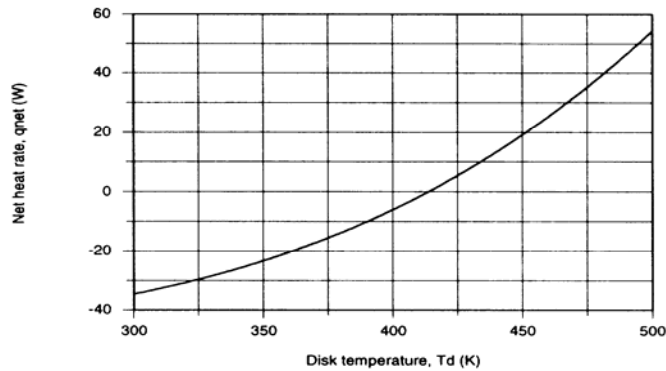

**COMMENTS:** The *IHT* workspace for the foregoing analysis is shown below.

**// Radiation Tool - Three Surface Enclosure, Furnace Disk Enclosure:**

```

/* The net heat rate leaving A1 in terms of the surface resistance is */
q1 = (Eb1 - J1) / ((1 - eps1) / (eps1 * A1)) // Eq 13.19
/* The net heat rate leaving A1 in terms of the net exchanges between enclosure surfaces is */
q1 = q12 + q13
/* where the net exchange rates expressed in terms of the space resistances are, Eq 13.20 */
q12 = (J1 - J2) / (1 / (A1 * F12))
q13 = (J1 - J3) / (1 / (A1 * F13))
/* The net heat rate leaving A2 in terms of the surface resistance is */
q2 = (Eb2 - J2) / ((1 - eps2) / (eps2 * A2)) // Eq 13.19
/* The net heat rate leaving A2 in terms of the net exchanges between enclosure surfaces is */
q2 = q21 + q23
/* where the net exchange rates expressed in terms of the space resistances are Eq 13.20 */
q21 = (J2 - J1) / (1 / (A2 * F21))
q23 = (J2 - J3) / (1 / (A2 * F23))
/* The net heat rate leaving A3 in terms of the surface resistance is */
q3 = (Eb3 - J3) / ((1 - eps3) / (eps3 * A3)) // Eq 13.19
/* The net heat rate leaving A3 in terms of the net exchanges between enclosure surfaces is */
q3 = q31 + q32
/* where the net exchange rates expressed in terms of the space resistances are, Eq 13.20 */
q31 = (J3 - J1) / (1 / (A3 * F31))
q32 = (J3 - J2) / (1 / (A3 * F32))

```

**// Emissive Powers:**

```

Eb1 = sigma * T1^4
Eb2 = sigma * T2^4
Eb3 = sigma * T3^4
sigma = 5.67e-8 // Stefan-Boltzmann constant, W/m^2.K^4

```

**// Radiation Tool - View Factor:**

```

/* The view factor, F12, for coaxial parallel disks, is */
F13 = 0.5 * (S - sqrt(S^2 - 4*(r3 / r1)^2))
// where
R1 = r1 / L
R3 = r3 / L
S = 1 + (1 + R3^2) / R1^2
// See Table 13.2 for schematic of this three-dimensional geometry.

```

**// Other View Factors and Areas Required:**

```

F12 = 1 - F13 // Summation rule, A1
F21 = A1 * F12 / A2 // Reciprocity rule
F23 = F21 // Symmetry condition
F31 = F13 // Symmetry condition
F32 = F12 // Symmetry condition
A1 = pi * r1^2 // Surface area, m^2
A2 = pi * r1 * L // Surface area, m^2
A3 = pi * r3^2 // Surface area, m^2

```

**// Overall plate energy balance, Eqs (1,2,3):**

```

qnet = - qrad - qcv - q3
qrad = eps32 * A3 * sigma * (T3^4 - Tsur^4)
qcv = hLbar * A3 * (T3 - Tinf)

```

Continued ...

## PROBLEM 13.118 (Cont.)

```
// Convection Tool - Free Convection, Flat Plate:
// Hot Surface Up (HSU) or Cold Surface Down (CSD)
NuLbar3 = NuL_bar_FC_HP_HSU(RaL3) // Eq 9.30 or 31
NuLbar3 = hLbar * L3 / k3
RaL3 = g * beta3 * deltaT3 * L3^3 / (nu3 * alpha3) //Eq 9.25
deltaT3 = abs(T3 - Tinf)
g = 9.8 // gravitational constant, m/s^2
// Evaluate properties at the film temperature, Tf1.
Tf = Tfluid_avg(Tinf, T3)
// The characteristic length, surface area and perimeter are
L3 = As3 / P3 // Eq 9.29
As3 = pi * r3^2
P3 = pi * r3
// Properties Tool - Air
// Air property functions : From Table A.4
// Units: T(K); 1 atm pressure
nu3 = nu_T("Air", Tf) // Kinematic viscosity, m^2/s
k3 = k_T("Air", Tf) // Thermal conductivity, W/m.K
alpha3 = alpha_T("Air", Tf) // Thermal diffusivity, m^2/s
Pr3 = Pr_T("Air", Tf) // Prandtl number
beta3 = 1/Tf // Volumetric coefficient of expansion, K^(-1); ideal gas

// Assigned Variables
r1 = 0.2 // Radius, m
r3 = 0.2 // Radius, m
L = 0.2 // Separation distance, m
T1 = 500 // Temperature, K
eps1 = 0.6 // Emissivity
T2 = 500 // Temperature, K
eps2 = 0.999 // Emissivity; avoiding 'division by zero error'
T3 = 400 // Temperature, K
eps32 = 0.8 // Emissivity; upper surface
eps3 = 0.999 // Emissivity; lower surface, enclosure side
Tinf = 300 // Ambient air temperature, K
Tsur = 300 // Surroundings temperature, K
```

### PROBLEM 13.119

**KNOWN:** Radiation shield facing hot wall at  $T_w = 400$  K is backed by an insulating material of known thermal conductivity and thickness which is exposed to ambient air and surroundings at 300 K.

**FIND:** (a) Heat loss per unit area from the hot wall, (b) Radiosity of the shield, and (c) Perform a parameter sensitivity analysis on the insulation system considering effects of shield reflectivity  $\rho_s$ , insulation thermal conductivity  $k$ , overall coefficient  $h$ , on the heat loss from the hot wall.

**SCHEMATIC:**

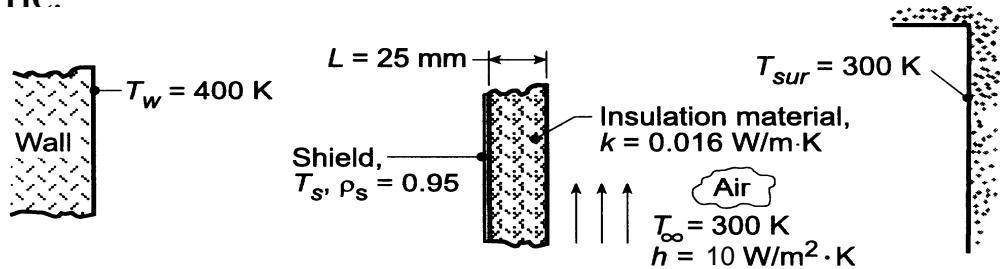

**ASSUMPTIONS:** (1) Wall is black surface of uniform temperature, (2) Shield and wall behave as parallel infinite plates, (3) Negligible convection in region between shield and wall, (4) Shield is diffuse-gray and very thin, (5) Prescribed coefficient  $h = 10$  W/m<sup>2</sup>·K is for convection and radiation.

**ANALYSIS:** (a) Perform an energy balance on the shield to obtain

$$q''_{w-s} = q''_{cond}$$

But the insulating material and the convection process at the exposed surface can be represented by a thermal circuit.

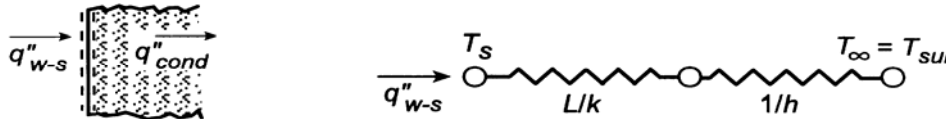

In equation form, using Eq.13.24 for the wall and shield,

$$q''_{w-s} = \frac{\sigma(T_w^4 - T_s^4)}{1/\varepsilon_w + 1/\varepsilon_s - 1} = \frac{T_s - T_\infty}{L/k + 1/h} \quad (1,2)$$

$$\frac{\sigma(400^4 - T_s^4)}{1 + 1/0.05 - 1} = \frac{(T_s - 300) \text{ K}}{(0.025/0.016 + 1/10) \text{ m}^2 \cdot \text{K/W}}$$

$$T_s = 350 \text{ K.}$$

where  $\varepsilon_s = 1 - \rho_s$ . Hence,

$$q''_{w-s} = \frac{(350 - 300) \text{ K}}{(0.025/0.016 + 1/10) \text{ m}^2 \cdot \text{K/W}} = 30 \text{ W/m}^2. \quad <$$

(b) Using the Eqs. (1) and (2) in the *IHT* workspace,  $q''_{w-s}$  can be computed and plotted for selected ranges of the insulation system variables,  $\rho_s$ ,  $k$ , and  $h$ . Intuitively we know that  $q''_{w-s}$  will decrease with increasing  $\rho_s$ , decreasing  $k$  and decreasing  $h$ . We chose to generate the following family of curves plotting  $q''_{w-s}$  vs.  $k$  for selected values of  $\rho_s$  and  $h$ .

Continued ...

**PROBLEM 13.119 (Cont.)**

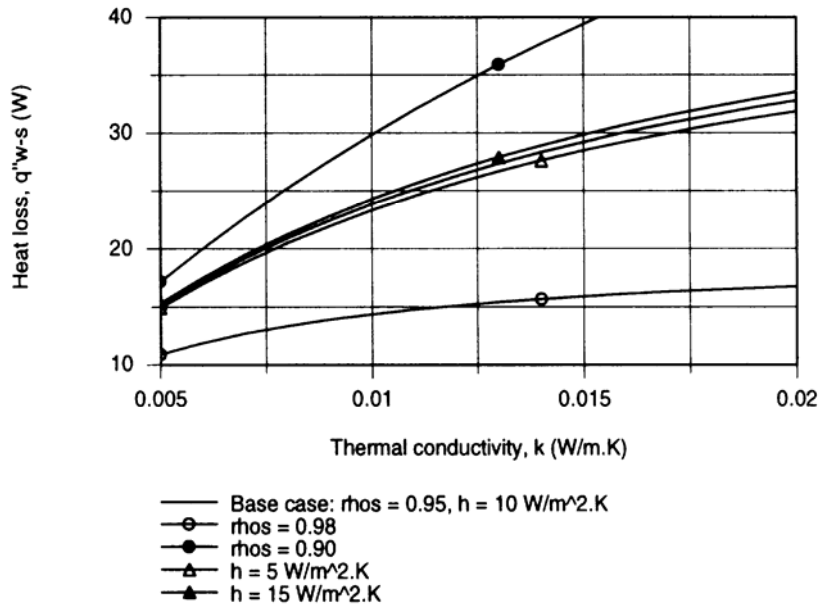

Considering the base condition with variable  $k$ , reducing  $k$  by a factor of 3, the heat loss is reduced by a factor of 2. The effect of changing  $h$  (4 to  $24 \text{ W/m}^2\cdot\text{K}$ ) has little influence on the heat loss.

However, the effect of shield reflectivity change is very significant. With  $\rho_s = 0.98$ , probably the upper limit of a practical reflector-type shield, the heat loss is reduced by a factor of two. To improve the performance of the insulation system, it is most advantageous to increase  $\rho_s$  and decrease  $k$ .

### PROBLEM 13.120

**KNOWN:** Diameter and surface temperature of a fire tube. Gas flow rate and temperature. Emissivity of tube and partition.

**FIND:** (a) Heat transfer per unit tube length,  $q'$ , without the partition, (b) Partition temperature,  $T_p$ , and heat rate with the partition, (c) Effect of flow rate and emissivity on  $q'$  and  $T_p$ . Effect of emissivity on radiative and convective contributions to  $q'$ .

**SCHEMATIC:**

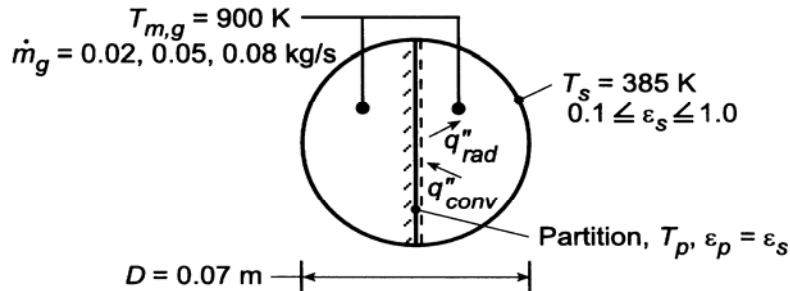

**ASSUMPTIONS:** (1) Fully-developed flow in duct, (2) Diffuse/gray surface behavior, (3) Negligible gas radiation.

**PROPERTIES:** Table A-4, air ( $T_{m,g} = 900$  K):  $\mu = 398 \times 10^{-7}$  N·s/m<sup>2</sup>,  $k = 0.062$  W/m·K,  $Pr = 0.72$ ; air ( $T_s = 385$  K):  $\mu = 224 \times 10^{-7}$  N·s/m<sup>2</sup>.

**ANALYSIS:** (a) Without the partition, heat transfer to the tube wall is only by convection. With  $\dot{m}_g = 0.05$  kg/s and  $Re_D = 4 \dot{m}_g / \pi D \mu = 4(0.05 \text{ kg/s}) / \pi (0.07 \text{ m}) 398 \times 10^{-7} \text{ N·s/m}^2 = 22,850$ , the flow is turbulent. From Eq. 8.61,

$$Nu_D = 0.027 Re_D^{4/5} Pr^{1/3} (\mu / \mu_s)^{0.14} = 0.027 (22,850)^{4/5} (0.72)^{1/3} (398 / 224)^{0.14} = 80.5$$

$$h = \frac{k}{D} Nu_D = \frac{0.062 \text{ W/m·K}}{0.07 \text{ m}} 80.5 = 71.3 \text{ W/m}^2 \cdot \text{K}$$

$$q' = h \pi D (T_{m,g} - T_s) = 71.3 \text{ W/m}^2 \cdot \text{K} (\pi) (0.07 \text{ m}) (900 - 385) = 8075 \text{ W/m} \quad <$$

(b) The temperature of the partition is determined from an energy balance which equates net radiation exchange with the tube wall to convection from the gas. Hence,  $q''_{rad} = q''_{conv}$ , where from Eq. 13.23,

$$q''_{rad} = \frac{\sigma (T_p^4 - T_s^4)}{\frac{1 - \epsilon_p}{\epsilon_p} + \frac{1}{F_{ps}} + \frac{1 - \epsilon_s}{\epsilon_s} \frac{A_p}{A_s}}$$

where  $F_{12} = 1$  and  $A_p/A_s = D/(\pi D/2) = 2/\pi = 0.637$ . The flow is now in a noncircular duct for which  $D_h = 4A_c/P = 4(\pi D^2/8)/(\pi D/2 + D) = \pi D/(\pi + 2) = 0.611 D = 0.0428$  m and  $\dot{m}_{1/2} = \dot{m}_g / 2 = 0.025$  kg/s. Hence,  $Re_D = \dot{m}_{1/2} D_h / A_c \mu = \dot{m}_{1/2} D_h / (\pi D^2/8) \mu = 8(0.025 \text{ kg/s}) (0.0428 \text{ m}) / \pi (0.07 \text{ m})^2 398 \times 10^{-7} \text{ N·s/m}^2 = 13,970$  and

$$Nu_D = 0.027 (13,970)^{4/5} (0.72)^{1/3} (398 / 224)^{0.14} = 54.3$$

$$h = \frac{k}{D_h} Nu_D = \frac{0.062 \text{ W/m·K}}{0.0428 \text{ m}} 54.3 = 78.7 \text{ W/m}^2 \cdot \text{K}$$

Continued ...

**PROBLEM 13.120 (Cont.)**

Hence, with  $\varepsilon_s = \varepsilon_p = 0.5$  and  $q''_{\text{conv}} = h(T_{\text{m,g}} - T_p)$ ,

$$\frac{5.67 \times 10^{-8} \text{ W/m}^2 \cdot \text{K}^4 (T_p^4 - 385^4) \text{ K}^4}{1 + 1 + 0.637} = 78.7 \text{ W/m}^2 \cdot \text{K} (900 - T_p) \text{ K}$$

$$21.5 \times 10^{-8} T_p^4 + 78.7 T_p - 71,302 = 0$$

Which may be solved to yield

$$T_p = 796 \text{ K}$$

The heat rate to one-half of the tube is then

$$q'_{1/2} = q'_{\text{ps}} + q'_{\text{conv}} = \frac{D\sigma(T_p^4 - T_s^4)}{\frac{1 - \varepsilon_p}{\varepsilon_p} + \frac{1}{F_{\text{ps}}} + \frac{1 - \varepsilon_s}{\varepsilon_s} \frac{A_p}{A_s}} + h(\pi D/2)(T_{\text{m,g}} - T_s)$$

$$q'_{1/2} = \frac{0.07 \text{ m} (5.67 \times 10^{-8} \text{ W/m}^2 \cdot \text{K}^4) (796.4^4 - 385^4) \text{ K}^4}{2.637} + 78.7 \text{ W/m}^2 \cdot \text{K} (0.110 \text{ m}) (900 - 385) \text{ K}$$

$$q'_{1/2} = 572 \text{ W/m} + 4458 \text{ W/m} = 5030 \text{ W/m}$$

The heat rate for the entire tube is

$$q' = 2q'_{1/2} = 10,060 \text{ W/m}$$

(c) The foregoing model was entered into the *IHT* workspace, and parametric calculations were performed to obtain the following results.

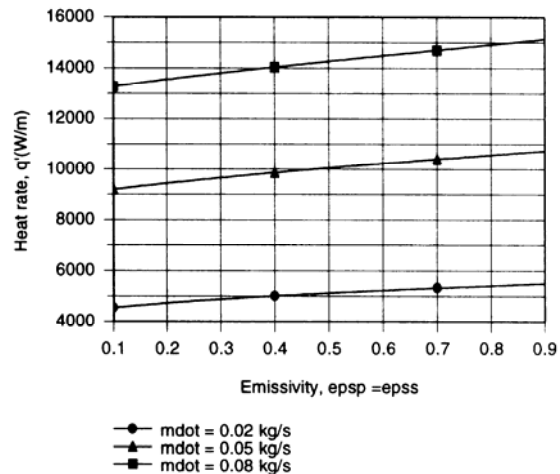
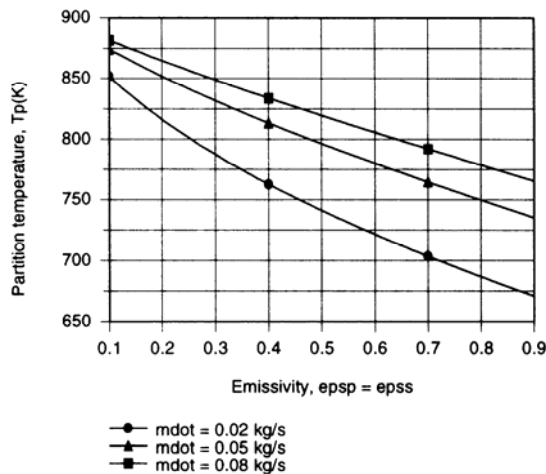

Radiation transfer from the partition increases with increasing  $\varepsilon_p = \varepsilon_s$ , thereby reducing  $T_p$  while increasing  $q'$ . Since  $h$  increases with increasing  $\dot{m}$ ,  $T_p$  and  $q'$  also increase with  $\dot{m}$ .

Continued ...

### PROBLEM 13.120 (Cont.)

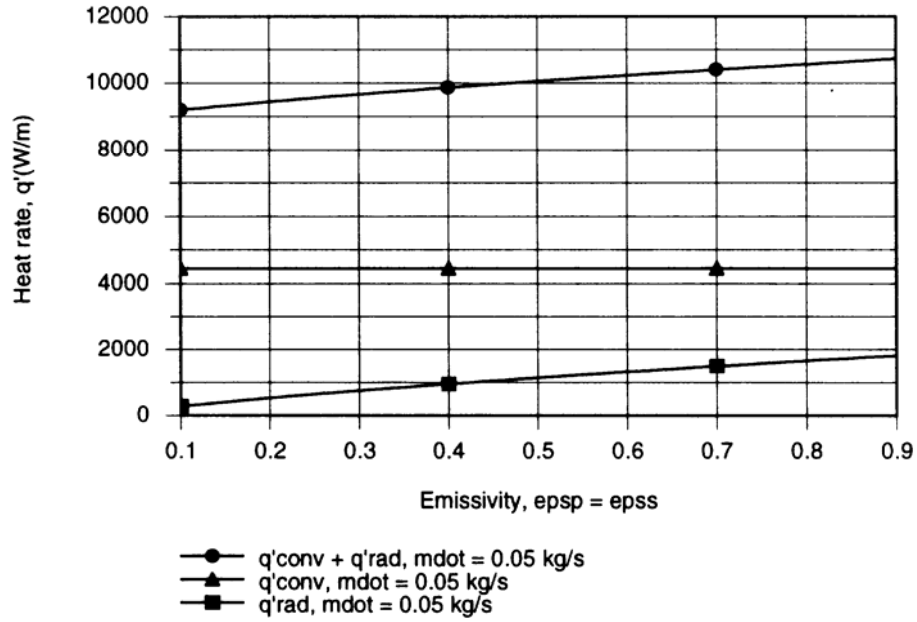

Although the radiative contribution to the heat rate increases with increasing  $\epsilon_p = \epsilon_s$ , it still remains small relative to convection.

**COMMENTS:** Contrasting the heat rate predicted for part (b) with that for part (a), it is clear that use of the partition enhances heat transfer to the tube. However, the effect is due primarily to an increase in  $h$  and secondarily to the addition of radiation.

### PROBLEM 13.121

**KNOWN:** Dimensions of horizontal air space separating plates of known temperature. Emissivity of end plates and interleaving aluminum sheets.

**FIND:** (a) Neglecting conduction or convection in the air, determine the heat flux through the system, (b) Neglecting convection and radiation, determine the heat flux through the system, (c) Heat flux through the system accounting for conduction and radiation, (d) Determine whether natural convection is negligible in part (c).

**SCHEMATIC:**

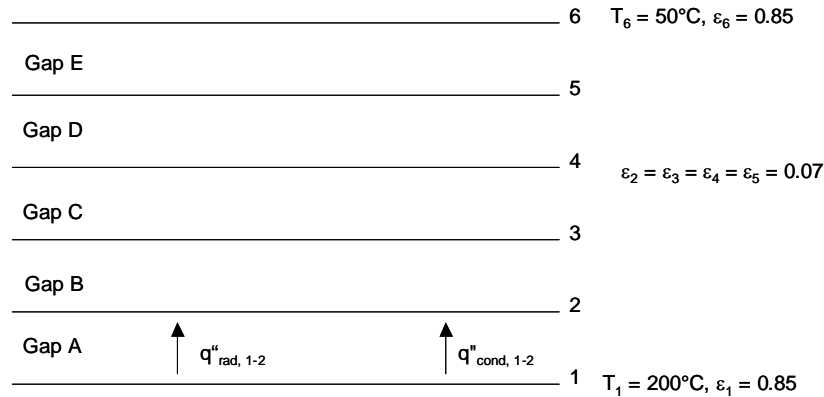

**ASSUMPTIONS:** (1) One-dimensional heat transfer, (2) Diffuse, gray surfaces, (3) Constant properties in each gap, (4) Negligible natural convection.

**PROPERTIES:** Air: Properties evaluated using IHT.

**ANALYSIS:** (a) The radiation heat flux across each of the five gaps is

$$q''_{\text{rad},1-2} = \frac{\sigma(T_1^4 - T_2^4)}{\frac{1}{\varepsilon_1} + \frac{1}{\varepsilon_2} - 1} = \frac{5.67 \times 10^{-8} \frac{\text{W}}{\text{m}^2 \cdot \text{K}^4} [(473\text{K})^4 - T_2^4]}{\frac{1}{0.85} + \frac{1}{0.07} - 1} \quad (1)$$

$$q''_{\text{rad},2-3} = \frac{\sigma(T_2^4 - T_3^4)}{\frac{1}{\varepsilon_2} + \frac{1}{\varepsilon_3} - 1} = \frac{5.67 \times 10^{-8} \frac{\text{W}}{\text{m}^2 \cdot \text{K}^4} [T_2^4 - T_3^4]}{\frac{1}{0.07} + \frac{1}{0.07} - 1} \quad (2)$$

$$q''_{\text{rad},3-4} = \frac{\sigma(T_3^4 - T_4^4)}{\frac{1}{\varepsilon_3} + \frac{1}{\varepsilon_4} - 1} = \frac{5.67 \times 10^{-8} \frac{\text{W}}{\text{m}^2 \cdot \text{K}^4} [T_3^4 - T_4^4]}{\frac{1}{0.07} + \frac{1}{0.07} - 1} \quad (3)$$

Continued...



**PROBLEM 13.121 (Cont.)**

$$q_{\text{rad},4-5}'' = \frac{\sigma(T_4^4 - T_5^4)}{\frac{1}{\epsilon_4} + \frac{1}{\epsilon_5} - 1} = \frac{5.67 \times 10^{-8} \frac{\text{W}}{\text{m}^2 \cdot \text{K}^4} [T_4^4 - T_5^4]}{\frac{1}{0.07} + \frac{1}{0.07} - 1} \quad (4)$$

$$q_{\text{rad},5-6}'' = \frac{\sigma(T_5^4 - T_6^4)}{\frac{1}{\epsilon_5} + \frac{1}{\epsilon_6} - 1} = \frac{5.67 \times 10^{-8} \frac{\text{W}}{\text{m}^2 \cdot \text{K}^4} [T_5^4 - (325\text{K})^4]}{\frac{1}{0.07} + \frac{1}{0.85} - 1} \quad (5)$$

where

$$q_{\text{rad}}'' = q_{\text{rad},1-2}'' = q_{\text{rad},2-3}'' = q_{\text{rad},3-4}'' = q_{\text{rad},4-5}'' = q_{\text{rad},5-6}'' \quad (6)$$

Solving Eqns. (1) through (6) simultaneously yields

$$T_2 = 460.5 \text{ K}, T_3 = 433.5 \text{ K}, T_4 = 400.1 \text{ K}, T_5 = 355.4 \text{ K}, q_{\text{rad}}'' = 19.89 \text{ W/m}^2 \quad <$$

(b) The conduction heat flux across each of the five gaps is

$$q_{\text{cond}}'' = \frac{k_A}{L}(T_1 - T_2) \quad (7)$$

where  $k_A$  is the thermal conductivity of air evaluated at  $\bar{T}_A = (T_1 + T_2)/2$ . Likewise,

$$q_{\text{cond},2-3}'' = \frac{k_B}{L}(T_2 - T_3); \quad k_B = k_{\text{air}} \left( (T_2 + T_3)/2 \right) \quad (8)$$

$$q_{\text{cond},3-4}'' = \frac{k_C}{L}(T_3 - T_4); \quad k_C = k_{\text{air}} \left( (T_3 + T_4)/2 \right) \quad (9)$$

$$q_{\text{cond},4-5}'' = \frac{k_D}{L}(T_4 - T_5); \quad k_D = k_{\text{air}} \left( (T_4 + T_5)/2 \right) \quad (10)$$

$$q_{\text{cond},5-6}'' = \frac{k_E}{L}(T_5 - T_6); \quad k_E = k_{\text{air}} \left( (T_5 + T_6)/2 \right) \quad (11)$$

where

$$q_{\text{cond}}'' = q_{\text{cond},1-2}'' = q_{\text{cond},2-3}'' = q_{\text{cond},3-4}'' = q_{\text{cond},4-5}'' = q_{\text{cond},5-6}'' \quad (12)$$

Continued...

### PROBLEM 13.121 (Cont.)

Solving Eqns. (7) through (12) simultaneously and using IHT to evaluate  $k_A$ ,  $k_B$ ,  $k_C$ ,  $k_D$  and  $k_E$  yields

$$T_2 = 446.5 \text{ K}, T_3 = 418.6 \text{ K}, T_4 = 389.1 \text{ K}, T_5 = 357.4 \text{ K}, q''_{\text{cond}} = 100.6 \text{ W/m}^2 \quad <$$

(c) For each gap,  $q'' = q''_{\text{cond}} + q''_{\text{rad}}$ . Hence,

$$q''_{1-2} = q''_{\text{rad},1-2} + q''_{\text{cond},1-2} \quad (13)$$

$$q''_{2-3} = q''_{\text{rad},2-3} + q''_{\text{cond},2-3} \quad (14)$$

$$q''_{3-4} = q''_{\text{rad},3-4} + q''_{\text{cond},3-4} \quad (15)$$

$$q''_{4-5} = q''_{\text{rad},4-5} + q''_{\text{cond},4-5} \quad (16)$$

$$q''_{5-6} = q''_{\text{rad},5-6} + q''_{\text{cond},5-6} \quad (17)$$

$$\text{where } q'' = q''_{1-2} = q''_{2-3} = q''_{3-4} = q''_{4-5} = q''_{5-6} \quad (18)$$

Solving Eqns. (1) through (5), (8) through (11), and (13) through (18) simultaneously and using IHT to evaluate  $k_A$ ,  $k_B$ ,  $k_C$ ,  $k_D$  and  $k_E$  yields

$$T_2 = 450.2 \text{ K}, T_3 = 421.9 \text{ K}, T_4 = 391.2 \text{ K}, T_5 = 357.4 \text{ K}, q'' = 122.1 \text{ W/m}^2 \quad <$$

(d) The Rayleigh number for gap A is

$$\text{Ra}_{L,A} = \frac{g\beta(T_1 - T_2)L^3}{\nu\alpha}$$

where  $T_1 = 473 \text{ K}$  and  $T_2 = 450.2 \text{ K}$ . Therefore,  $\bar{T} = (473\text{K} + 450.2\text{K})/2 = 461.1\text{K}$ . Hence,

$$\beta = \frac{1}{\bar{T}} = \frac{1}{461.1\text{K}}, \nu = 3.381 \times 10^{-5} \frac{\text{m}^2}{\text{s}} \text{ and } \alpha = 4.931 \times 10^{-5} \frac{\text{m}^2}{\text{s}}$$

from which

$$\text{Ra}_{L,A} = \frac{9.81 \frac{\text{m}}{\text{s}^2} \frac{1}{461.1\text{K}} \times (473\text{K} - 450.2\text{K}) \times 0.01\text{m}^3}{3.381 \times 10^{-5} \frac{\text{m}^2}{\text{s}} \times 4.931 \times 10^{-5} \frac{\text{m}^2}{\text{s}}} = 289.2$$

Continued...

### PROBLEM 13.121 (Cont.)

Repeating the calculation for the remaining gaps yields

$$Ra_{L,B} = 463, Ra_{L,C} = 690, Ra_{L,D} = 1104, Ra_{L,E} = 1747.$$

The largest Rayleigh number is slightly higher than the critical value of 1703. Therefore, natural convection in the gaps is negligible. <

**COMMENTS:** (1) Ignoring the presence of the air will result in an estimated heat flux that is only 16% of the actual value. One must carefully account for conduction or convection effects in radiation problems, in particular when the radiation occurs in conjunction with low emissivity surfaces. (2) The heat flux for combined radiation and conduction exceeds the sum of the individual components acting alone. This is due to the non-linear effects brought about by the fourth-power dependence of the radiation heat flux upon temperature and property variations. (3) The foil temperatures vary for the three simulations. Can you explain why different temperatures exist for the three cases?

IHT code for solution of part (c) is shown below.

```
T1 = 200 + 273
T6 = 50 + 273
emiss1 = 0.85
emiss6 = 0.85
emiss2 = 0.07
emiss3 = emiss2
emiss4 = emiss3
emiss5 = emiss4
sigma=5.67*10^-8

// Air property functions : From Table A.4
// Units: T(K); 1 atm pressure

k12 = k_T("Air",T12) // Thermal conductivity, W/m-K
k23 = k_T("Air",T23) // Thermal conductivity, W/m-K
k34 = k_T("Air",T34) // Thermal conductivity, W/m-K
k45 = k_T("Air",T45) // Thermal conductivity, W/m-K
k56 = k_T("Air",T56) // Thermal conductivity, W/m-K
T12 = (T1 + T2)/2
T23 = (T2 + T3)/2
T34 = (T3 + T4)/2
T45 = (T4 + T5)/2
T56 = (T5 + T6)/2

L = 0.01

//March through the gaps

qrad12 = sigma*(T1^4-T2^4)/(1/emiss1+1/emiss2-1)
qcon12 = k12*(T1-T2)/L
qtot = qrad12+qcon12

qrad23 = sigma*(T2^4-T3^4)/(1/emiss2+1/emiss3-1)
qcon23 = k23*(T2-T3)/L
qtot = qrad23+qcon23
```

Continued...

### PROBLEM 13.121 (Cont.)

$$\begin{aligned}q_{\text{rad}34} &= \sigma(T_3^4 - T_4^4) / (1/\epsilon_{\text{miss}3} + 1/\epsilon_{\text{miss}4} - 1) \\q_{\text{con}34} &= k_{34}(T_3 - T_4)/L \\q_{\text{tot}} &= q_{\text{rad}34} + q_{\text{con}34}\end{aligned}$$

$$\begin{aligned}q_{\text{rad}45} &= \sigma(T_4^4 - T_5^4) / (1/\epsilon_{\text{miss}4} + 1/\epsilon_{\text{miss}5} - 1) \\q_{\text{con}45} &= k_{45}(T_4 - T_5)/L \\q_{\text{tot}} &= q_{\text{rad}45} + q_{\text{con}45}\end{aligned}$$

$$\begin{aligned}q_{\text{rad}56} &= \sigma(T_5^4 - T_6^4) / (1/\epsilon_{\text{miss}5} + 1/\epsilon_{\text{miss}6} - 1) \\q_{\text{con}56} &= k_{56}(T_5 - T_6)/L \\q_{\text{tot}} &= q_{\text{rad}56} + q_{\text{con}56}\end{aligned}$$

//Note that one must input initial temperatures of around 350 K for all values, or else the system of equations will not converge.

### PROBLEM 13.122

**KNOWN:** Diameters, temperatures, and emissivities of concentric spheres.

**FIND:** Rate at which nitrogen is vented from the inner sphere. Effect of radiative properties on evaporation rate.

**SCHEMATIC:**

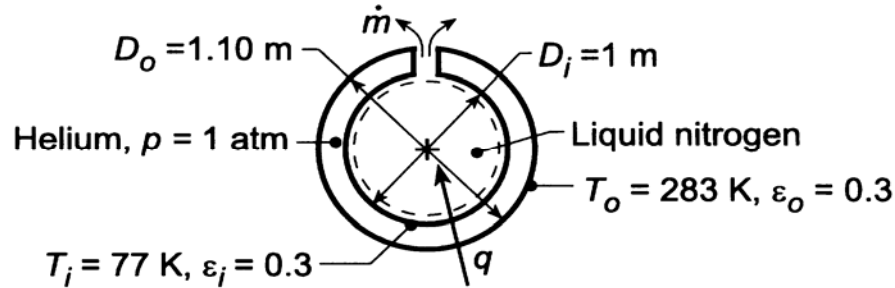

**ASSUMPTIONS:** Diffuse-gray surfaces.

**PROPERTIES:** Liquid nitrogen (given):  $h_{fg} = 2 \times 10^5 \text{ J/kg}$ ; *Table A-4*, Helium ( $\bar{T} = (T_i + T_o)/2 = 180 \text{ K}$ , 1 atm):  $\nu = 51.3 \times 10^{-6} \text{ m}^2/\text{s}$ ,  $k = 0.107 \text{ W/m}\cdot\text{K}$ ,  $\alpha = 76.2 \times 10^{-6} \text{ m}^2/\text{s}$ ,  $\text{Pr} = 0.673$ ,  $\beta = 0.00556 \text{ K}^{-1}$ .

**ANALYSIS:** (a) Performing an energy balance for a control surface about the liquid nitrogen, it follows that  $q = q_{\text{conv}} + q_{\text{rad}} = \dot{m}h_{fg}$ . The convection heat rate is given by Eqs. 9.61 through 9.63.

$$L_s = \frac{\left(\frac{1}{r_i} - \frac{1}{r_o}\right)^{4/3}}{2^{1/3} \left(r_i^{-7/5} + r_o^{-7/5}\right)^{5/3}} = \frac{\left(\frac{1}{0.5\text{m}} - \frac{1}{0.55\text{m}}\right)^{4/3}}{2^{1/3} \left(0.5\text{m}^{-7/5} + 0.55\text{m}^{-7/5}\right)^{5/3}} = 0.0057\text{m}$$

The Rayleigh number is

$$\text{Ra}_s = \left| \frac{g\beta(T_i - T_o)L_s^3}{\nu\alpha} \right| = \left| \frac{9.8\text{m/s}^2(0.00556\text{K}^{-1})(77 - 283)\text{K}(0.0057\text{m})^3}{51.3 \times 10^{-6}\text{m}^2/\text{s} \times 76.2 \times 10^{-6}\text{m}^2/\text{s}} \right| = 529$$

From Eq. 9.62,

$$\frac{k_{\text{eff}}}{k} = 0.74 \left( \frac{\text{Pr}}{0.861 + \text{Pr}} \right)^{1/4} \text{Ra}_s^{1/4} = 0.74 \left( \frac{0.673}{0.861 + 0.673} \right)^{1/4} 529^{1/4} = 2.89$$

Therefore,  $k_{\text{eff}} = 2.89 \times 0.107 \text{ W/m}\cdot\text{K} = 0.309 \text{ W/m}\cdot\text{K}$ . From Eq. 9.61,

$$q_{\text{conv}} = \frac{4\pi k_{\text{eff}}(T_i - T_o)}{(1/r_i) - (1/r_o)} = \frac{4 \times \pi \times 0.309 \text{ W/m}\cdot\text{K} \times (206\text{K})}{(1/0.5\text{m}) - (1/0.55\text{m})} = 4399\text{W}$$

Continued...

### PROBLEM 13.122 (Cont.)

From Table 13.21,

$$q_{\text{rad}} = q_{\text{oi}} = \frac{\sigma \pi D_1^2 (T_o^4 - T_1^4)}{1/\epsilon_i + ((1 - \epsilon_o)/\epsilon_o)(D_i/D_o)^2}$$

$$= \frac{(5.67 \times 10^{-8} \text{ W/m}^2 \cdot \text{K}^4) \pi (1 \text{ m})^2 (283^4 - 77^4) \text{ K}^4}{1/0.3 + (0.7/0.3)(1/1.1)^2} = 216 \text{ W.}$$

Hence,  $\dot{m} = q/h_{\text{fg}} = (4399 + 216) \text{ W} / 2 \times 10^5 \text{ J/kg} = 0.023 \text{ kg/s.}$  <

With the cavity evacuated, *IHT* was used to compute the radiation heat rate as a function of  $\epsilon_i = \epsilon_o$ .

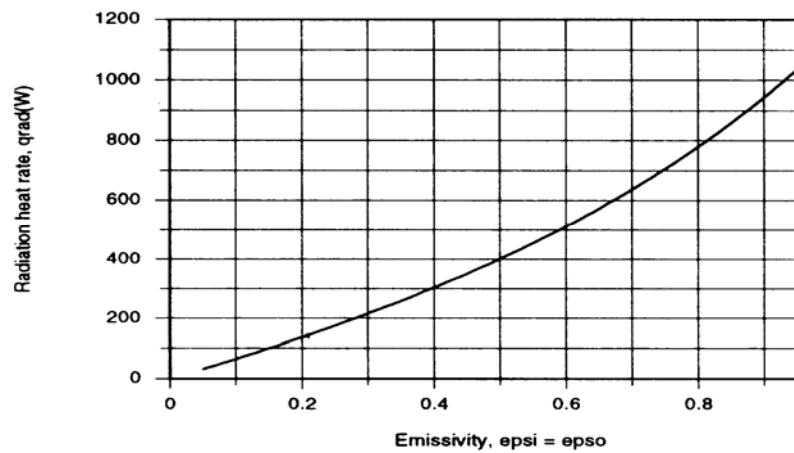

Clearly, significant advantage is associated with reducing the emissivities and  $q_{\text{rad}} = 31.8 \text{ W}$  for  $\epsilon_i = \epsilon_o = 0.05$ .

**COMMENTS:** The convection heat rate is too large. It could be reduced by replacing He with a gas of smaller  $k$ , a cryogenic insulator (Table A.3), or a vacuum. Radiation effects are second order for small values of the emissivity.

### PROBLEM 13.123

**KNOWN:** Dimensions, emissivity and upper temperature limit of coated panel. Arrangement and power dissipation of a radiant heater. Temperature of surroundings.

**FIND:** (a) Minimum panel-heater separation, neglecting convection, (b) Minimum panel-heater separation, including convection.

**SCHEMATIC:**

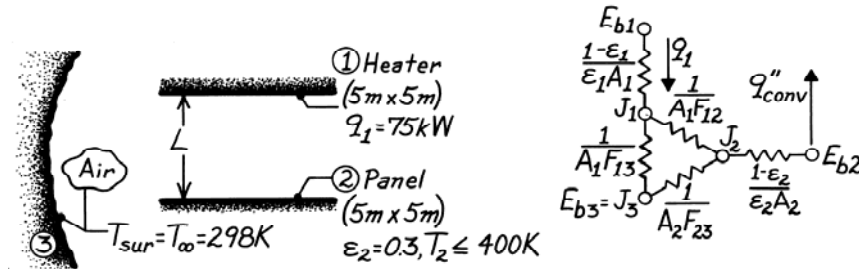

**ASSUMPTIONS:** (1) Top and bottom surfaces of heater and panel, respectively, are adiabatic, (2) Bottom and top surfaces of heater and panel, respectively are diffuse-gray, (3) Surroundings form a large enclosure about the heater-panel arrangement, (4) Steady-state conditions, (5) Heater power is dissipated entirely as radiation (negligible convection), (6) Air is quiescent and convection from panel may be approximated as free convection from a horizontal surface, (7) Air is at atmospheric pressure.

**PROPERTIES:** Table A-4, Air ( $T_f = (400 + 298)/2 \approx 350$  K, 1 atm):  $\nu = 20.9 \times 10^{-6}$  m<sup>2</sup>/s,  $k = 0.03$  W/m·K,  $Pr = 0.700$ ,  $\alpha = 29.9 \times 10^{-6}$  m<sup>2</sup>/s,  $\beta = 2.86 \times 10^{-3}$  K<sup>-1</sup>.

**ANALYSIS:** (a) Neglecting convection effects, the panel constitutes a floating potential for which the net radiative transfer must be zero. That is, the panel behaves as a re-radiating surface for which  $E_{b2} = J_2$ . Hence

$$q_1 = \frac{J_1 - E_{b2}}{1/A_1 F_{12}} + \frac{J_1 - E_{b3}}{1/A_1 F_{13}} \quad (1)$$

and evaluating terms

$$E_{b2} = \sigma T_2^4 = 5.67 \times 10^{-8} \text{ W/m}^2 \cdot \text{K}^4 (400 \text{ K})^4 = 1452 \text{ W/m}^2$$

$$E_{b3} = \sigma T_3^4 = 5.67 \times 10^{-8} \text{ W/m}^2 \cdot \text{K}^4 (298 \text{ K})^4 = 447 \text{ W/m}^2$$

$$F_{13} = 1 - F_{12} \quad A_1 = 25 \text{ m}^2$$

find that

$$\frac{75,000 \text{ W}}{25 \text{ m}^2} = \frac{J_1 - 1452}{1/F_{12}} + \frac{J_1 - 447}{1/(1 - F_{12})}$$

$$3000 \text{ W/m}^2 = F_{12} (J_1 - 1452) + (J_1 - 447) - F_{12} (J_1 - 447)$$

$$J_1 = 3447 + 1005 F_{12}. \quad (2)$$

Performing a radiation balance on the panel yields

$$\frac{J_1 - E_{b2}}{1/A_1 F_{12}} = \frac{E_{b2} - E_{b3}}{1/A_2 F_{23}}.$$

Continued ...

**PROBLEM 13.123 (Cont.)**

With  $A_1 = A_2$  and  $F_{23} = 1 - F_{12}$

$$F_1 (J_1 - 1452) = (1 - F_{12})(1452 - 447)$$

or

$$447F_{12} = F_{12}J_1 - 1005. \quad (3)$$

Substituting for  $J_1$  from Eq. (2), find

$$447F_{12} = F_{12} (3447 + 1005F_{12}) - 1005$$

$$1005F_{12}^2 + 3000F_{12} - 1005 = 0$$

$$F_{12} = 0.30.$$

Hence from Fig. 13.4, with  $X/L = Y/L$  and  $F_{ij} = 0.3$ ,

$$X/L \approx 1.45$$

$$L \approx 5 \text{ m} / 1.45 = 3.45 \text{ m.} \quad <$$

(b) Accounting for convection from the panel, the net radiation transfer is no longer zero at this surface and  $E_{b2} \neq J_2$ . It then follows that

$$q_1 = \frac{J_1 - J_2}{1/A_1 F_{12}} + \frac{J_1 - E_{b3}}{1/A_1 F_{13}} \quad (4)$$

where, from an energy balance on the panel,

$$\frac{J_2 - E_{b2}}{(1 - \varepsilon_2)/\varepsilon_2 A_2} = q_{\text{conv},2} = \bar{h} A_2 (T_2 - T_\infty). \quad (5)$$

With  $L \equiv A_s/P = 25 \text{ m}^2/20 \text{ m} = 1.25 \text{ m}$ ,

$$\text{Ra}_L = \frac{g\beta(T_s - T_\infty)L^3}{\nu\alpha} = \frac{9.8 \text{ m/s}^2 (2.86 \times 10^{-3} \text{ K}^{-1})(102 \text{ K})(1.25 \text{ m})^3}{(20.9 \times 29.9) 10^{-12} \text{ m}^4/\text{s}^2} = 8.94 \times 10^9.$$

Hence, from Eq. 9.31

$$\overline{\text{Nu}}_L = 0.15 \text{Ra}_L^{1/3} = 0.15 (8.94 \times 10^9)^{1/3} = 311$$

$$\bar{h} = 311 \text{ k/L} = 311 \frac{0.03 \text{ W/m} \cdot \text{K}}{1.25 \text{ m}} = 7.46 \text{ W/m}^2 \cdot \text{K}$$

$$q''_{\text{conv},2} = 7.46 \text{ W/m}^2 \cdot \text{K} (102 \text{ K}) = 761 \text{ W/m}^2.$$

From Eq. (5)

$$J_2 = E_{b2} + \frac{1 - \varepsilon_2}{\varepsilon_2} q''_{\text{conv},2} = 1452 + \frac{0.7}{0.3} 761 = 3228 \text{ W/m}^2.$$

Continued ...



### PROBLEM 13.123 (Cont.)

From Eq. (4),

$$\frac{75,000}{25} = \frac{J_1 - 3228}{1/F_{12}} + \frac{J_1 - 447}{1/(1 - F_{12})}$$

$$3000 = F_{12}(J_1 - 3228) + J_1 - 447 - F_{12}(J_1 - 447)$$

$$J_1 = 3447 + 2781F_{12}. \quad (6)$$

From an energy balance on the panel,

$$\frac{J_1 - J_2}{1/A_1 F_{12}} + \frac{E_{b3} - J_2}{1/A_2 F_{23}} = \frac{J_2 - E_{b2}}{(1 - \varepsilon_2)/\varepsilon_2 A_2} = q_{\text{conv},2}$$

$$F_{12}(J_1 - 3228) + (1 - F_{12})(447 - 3228) = 761$$

$$F_{12}J_1 - 447F_{12} = 3542.$$

Substituting from Eq. (6),

$$F_{12}(3447 + 2781F_{12}) - 447F_{12} = 3542$$

$$2781F_{12}^2 + 3000F_{12} - 3542 = 0$$

$$F_{12} = 0.71.$$

Hence from Fig. 13.4, with  $X/L = Y/L$  and  $F_{ij} = 0.71$ ,

$$X/L = 5.7$$

$$L \approx 5 \text{ m} / 5.7 = 0.88 \text{ m}. \quad <$$

**COMMENTS:** (1) The results are independent of the heater surface radiative properties. (2) Convection at the heater surface would reduce the heat rate  $q_1$  available for radiation exchange and hence reduce the value of  $L$ .

### PROBLEM 13.124

**KNOWN:** Diameter and emissivity of rod heater. Diameter and position of reflector. Width, emissivity, temperature and position of coated panel. Temperature of air and large surroundings.

**FIND:** (a) Equivalent thermal circuit, (b) System of equations for determining heater and reflector temperatures. Values of temperatures for prescribed conditions, (c) Electrical power needed to operate heater.

**SCHEMATIC:**

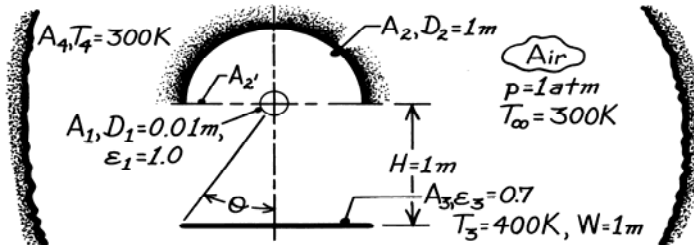

**ASSUMPTIONS:** (1) Steady-state conditions, (2) Diffuse-gray surfaces, (3) Large surroundings act as blackbody, (4) Surfaces are infinitely long (negligible end effects), (5) Air is quiescent, (6) Negligible convection at reflector, (7) Reflector and panel are perfectly insulated.

**PROPERTIES:** Table A-4, Air ( $T_f = 350$  K, 1 atm):  $k = 0.03$  W/m·K,  $\nu = 20.9 \times 10^{-6}$  m<sup>2</sup>/s,  $\alpha = 29.9 \times 10^{-6}$  m<sup>2</sup>/s, Pr = 0.70; ( $T_f = (1295 + 300)/2 = 800$  K):  $k = 0.0573$  W/m·K,  $\nu = 84.9 \times 10^{-6}$  m<sup>2</sup>/s,  $\alpha = 120 \times 10^{-6}$  m<sup>2</sup>/s.

**ANALYSIS:** (a) We have assumed blackbody behavior for  $A_1$  and  $A_4$ ; hence,  $J = E_b$ . Also,  $A_2$  is insulated and has negligible convection; hence  $q = 0$  and  $J_2 = E_{b2}$ . The equivalent thermal circuit is:

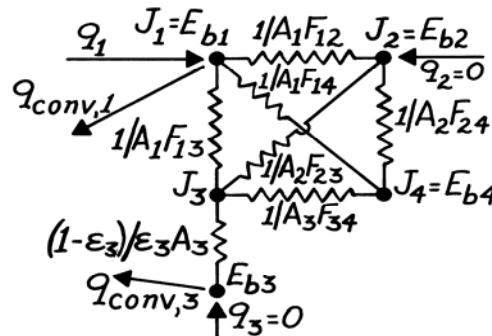

(b) Performing surface energy balances at 1, 2 and 3:

$$q_1 - q_{\text{conv},1} = \frac{E_{b1} - E_{b2}}{1/A_1 F_{12}} + \frac{E_{b1} - J_3}{1/A_1 F_{13}} + \frac{E_{b1} - E_{b4}}{1/A_1 F_{14}} \quad (1)$$

$$0 = \frac{E_{b1} - E_{b2}}{1/A_2 F_{21}} + \frac{J_3 - E_{b2}}{1/A_2 F_{23}} + \frac{E_{b4} - E_{b2}}{1/A_2 F_{24}} \quad (2)$$

$$\frac{J_3 - E_{b3}}{(1 - \epsilon_3)/\epsilon_3 A_3} = \frac{E_{b1} - J_3}{1/A_3 F_{31}} + \frac{E_{b2} - J_3}{1/A_3 F_{32}} + \frac{E_{b4} - J_3}{1/A_3 F_{34}} \quad (3a)$$

where

$$\frac{J_3 - E_{b3}}{(1 - \epsilon_3)/\epsilon_3 A_3} = q_{\text{conv},3} \quad (3b)$$

Continued ...

### PROBLEM 13.124 (Cont.)

Solution procedure with  $E_{b3}$  and  $E_{b4}$  known: Evaluate  $q_{\text{conv},3}$  and use Eq. (3b) to obtain  $J_3$ ; Solve Eqs. (2) and (3a) simultaneously for  $E_{b1}$  and  $E_{b2}$  and hence  $T_1$  and  $T_2$ ; Evaluate  $q_{\text{conv},1}$  and use Eq. (1) to obtain  $q_1$ .

For *free convection* from a heated, horizontal plate using Eqs. 9.29, 9.25, and 9.31:

$$L_c = \frac{A_s}{P} = \frac{(W \times L)}{(2L + 2W)} \approx \frac{W}{2} = 0.5 \text{ m}$$

$$\text{Ra}_L = \frac{g\beta(T_3 - T_\infty)L_c^3}{\alpha\nu} = \frac{9.8 \text{ m/s}^2 (350 \text{ K})^{-1} (100 \text{ K})(0.5 \text{ m})^3}{20.9 \times 29.9 \times 10^{-12} \text{ m}^4/\text{s}^2} = 5.6 \times 10^8$$

$$\overline{\text{Nu}}_L = 0.15 \text{Ra}_L^{1/3} = 0.15 (5.6 \times 10^8)^{1/3} = 123.6$$

$$\overline{h}_3 = \frac{k}{L_c} \overline{\text{Nu}}_L = \frac{0.03 \text{ W/m} \cdot \text{K} \times 123.6}{0.5 \text{ m}} = 7.42 \text{ W/m}^2 \cdot \text{K}.$$

$$q''_{\text{conv},3} = \overline{h}_3 (T_3 - T_\infty) = 742 \text{ W/m}^2.$$

Hence, with

$$E_{b3} = \sigma T_3^4 = 5.67 \times 10^{-8} \text{ W/m}^2 \cdot \text{K}^4 (400 \text{ K})^4 = 1451 \text{ W/m}^2$$

using Eq. (3b) find

$$J_3 = E_{b3} + \frac{1 - \varepsilon_3}{\varepsilon_3 A_3} q_{\text{conv},3} = (1451 + [0.3/0.7]742) = 1769 \text{ W/m}^2.$$

*View Factors:* From symmetry, it follows that  $F_{12} = 0.5$ . With  $\theta = \tan^{-1}(W/2)/H = \tan^{-1}(0.5) = 26.57^\circ$ , it follows that

$$F_{13} = 2\theta/360 = 0.148.$$

From summation and reciprocity relations,

$$F_{14} = 1 - F_{12} - F_{13} = 0.352$$

$$F_{21} = (A_1/A_2)F_{12} = (2D_1/D_2)F_{12} = 0.02 \times 0.5 = 0.01$$

$$F_{23} = (A_3/A_2)F_{32} = (2/\pi)(F_{32}' - F_{31}).$$

For  $X/L = 1$ ,  $Y/L \approx \infty$ , find from Fig. 13.4 that  $F_{32}' \approx 0.42$ . Also find,

$$F_{31} = (A_1/A_3)F_{13} = (\pi \times 0.01/1)0.148 = 0.00465 \approx 0.005$$

$$F_{23} = (2/\pi)(0.42 - 0.005) = 0.264$$

$$F_{22} \approx 1 - F_{22}' = 1 - (A_2'/A_2)F_{22}' = 1 - (2/\pi) = 0.363$$

$$F_{24} = 1 - F_{21} - F_{22} - F_{23} = 0.363$$

Continued ...

**PROBLEM 13.124 (Cont.)**

$$F_{31} = 0.005, \quad F_{32} = 0.415$$

$$F_{34} = 1 - F_{32}' = 1 - 0.42 = 0.58.$$

With  $E_{b4} = \sigma T_4^4 = 5.67 \times 10^{-8} \text{ W/m}^2 \cdot \text{K}^4 (300 \text{ K})^4 = 459 \text{ W/m}^2$ ,

$$\begin{aligned} \text{Eq. (3a)} \rightarrow 0.005(E_{b1} - 1769) + 0.415(E_{b2} - 1769) + 0.58(459 - 1769) &= 742 \\ 0.005E_{b1} + 0.415E_{b2} &= 2245 \end{aligned} \quad (4)$$

$$\begin{aligned} \text{Eq. (2)} \rightarrow 0.01(E_{b1} - E_{b2}) + 0.264(1769 - E_{b2}) + 0.363(459 - E_{b2}) &= 0 \\ 0.01E_{b1} - 0.637E_{b2} + 633.6 &= 0. \end{aligned} \quad (5)$$

Hence, manipulating Eqs. (4) and (5), find

$$E_{b2} = 0.0157E_{b1} + 994.7$$

$$0.005E_{b1} + (0.415)(0.0157E_{b1} + 994.7) = 2245.$$

$$E_{b1} = 159,322 \text{ W/m}^2 \quad T_1 = (E_{b1}/\sigma)^{1/4} = 1295 \text{ K} \quad <$$

$$E_{b2} = 0.0157(159,322) + 994.7 = 3496 \text{ W/m}^2 \quad T_2 = (E_{b2}/\sigma)^{1/4} = 498 \text{ K}. \quad <$$

(c) With  $T_1 = 1295 \text{ K}$ , then  $T_f = (1295 + 300)/2 \approx 800 \text{ K}$ , and using Eq. 9.33

$$Ra_D = \frac{g\beta(T_1 - T_\infty)D_1^3}{\alpha\nu} = \frac{9.8 \text{ m/s}^2 (1/800 \text{ K})(1295 - 300) \text{ K} (0.01 \text{ m})^3}{120 \times 84.9 \times 10^{-12} \text{ m}^4/\text{s}^2} = 1196$$

$$\overline{Nu}_D = 0.85Ra_D^{0.188} = 0.85(1196)^{0.188} = 3.22$$

$$\overline{h}_1 = (k/D_1)\overline{Nu}_D = (0.0573/0.01) \times 3.22 = 18.5 \text{ W/m}^2 \cdot \text{K}.$$

The convection heat flux is

$$q''_{\text{conv},1} = \overline{h}_1(T_1 - T_\infty) = 18.5(1295 - 300) = 18,407 \text{ W/m}^2,$$

Using Eq. (1), find

$$q''_1 = q''_{\text{conv},1} + F_{12}(E_{b1} - E_{b2}) + F_{13}(E_{b1} - J_3) + F_{14}(E_{b1} - E_{b4})$$

$$\begin{aligned} q''_1 &= 18,407 + 0.5(159,322 - 3496) \\ &\quad + 0.148(159,322 - 1769) + 0.352(159,322 - 459) \end{aligned}$$

$$q''_1 = 18,407 + (77,913 + 23,314 + 55,920)$$

$$q''_1 = 18,407 + 236,381 = 254,788 \text{ W/m}^2$$

$$q'_1 = \pi D_1 q''_1 = \pi(0.01)254,788 = 8000 \text{ W/m}. \quad <$$

**COMMENTS:** Although convection represents less than 8% of the net radiant transfer from the heater, it is equal to the net radiant transfer to the panel. Since the reflector is a reradiating surface, results are independent of its emissivity.

### PROBLEM 13.125

**KNOWN:** Temperature, power dissipation and emissivity of a cylindrical heat source. Surface emissivities of a parabolic reflector. Temperature of air and surroundings.

**FIND:** (a) Radiation circuit, (b) Net radiation transfer from the heater, (c) Net radiation transfer from the heater to the surroundings, (d) Temperature of reflector.

**SCHEMATIC:**

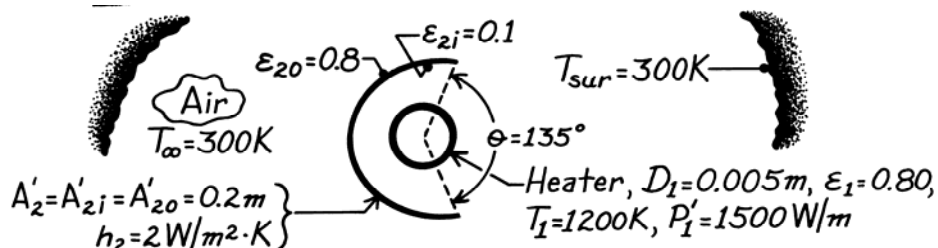

**ASSUMPTIONS:** (1) Steady-state conditions, (2) Heater and reflector are in quiescent and infinite air, (3) Surroundings are infinitely large, (4) Reflector is thin (isothermal), (5) Diffuse-gray surfaces.

**PROPERTIES:** Table A-4, Air ( $T_f = 750$  K, 1 atm):  $\nu = 76.37 \times 10^{-6} \text{ m}^2/\text{s}$ ,  $k = 0.0549 \text{ W/m}\cdot\text{K}$ ,  $\alpha = 109 \times 10^{-6} \text{ m}^2/\text{s}$ ,  $\text{Pr} = 0.702$ .

**ANALYSIS:** (a) The thermal circuit is

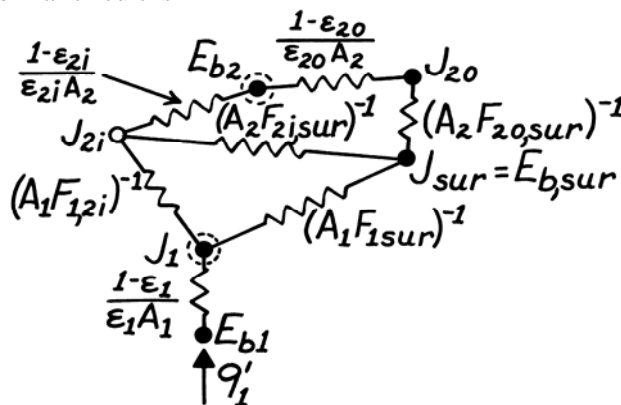

(b) Energy transfer from the heater is by radiation and free convection. Hence,

$$P'_1 = q'_1 + q'_{1,\text{conv}}$$

where

$$q'_{1,\text{conv}} = \bar{h}\pi D_1 (T_1 - T_\infty)$$

and

$$\text{Ra}_D = \frac{g\beta(T_1 - T_\infty)D^3}{\nu\alpha} = \frac{9.8 \text{ m/s}^2 (750 \text{ K})^{-1} (900 \text{ K})(0.005 \text{ m})^3}{76.37 \times 109 \times 10^{-12} \text{ m}^4/\text{s}^2} = 176.6.$$

Using the Churchill and Chu correlation of Chapter 9, find

$$\bar{\text{Nu}}_D = \left\{ 0.6 + \frac{0.387 \text{Ra}_D^{1/6}}{\left[ 1 + (0.559/\text{Pr})^{9/16} \right]^{8/27}} \right\}^2 = \left\{ 0.6 + \frac{0.387(176.6)^{1/6}}{\left[ 1 + (0.559/0.702)^{9/16} \right]^{8/27}} \right\}^2 = 1.85$$

$$\bar{h} = \bar{\text{Nu}}_D (k/D) = 1.85(0.0549 \text{ W/m}\cdot\text{K}/0.005 \text{ m}) = 20.3 \text{ W/m}^2 \cdot \text{K}.$$

Continued ...

**PROBLEM 13.125 (Cont.)**

Hence,

$$q'_{1,\text{conv}} = 20.3 \text{ W/m}^2 \cdot \text{K} \pi (0.005 \text{ m})(1200 - 300) \text{ K} = 287 \text{ W/m}$$

$$q'_1 = 1500 \text{ W/m} - 287 \text{ W/m} = 1213 \text{ W/m} \quad <$$

(c) The net radiative heat transfer from the heater to the surroundings is

$$q'_{1(\text{sur})} = A'_1 F_{1\text{sur}} (J_1 - J_{\text{sur}}).$$

The view factor is

$$F_{1\text{sur}} = (135/360) = 0.375$$

and the radiosities are

$$J_{\text{sur}} = \sigma T_{\text{sur}}^4 = 5.67 \times 10^{-8} \text{ W/m}^2 \cdot \text{K}^4 (300 \text{ K})^4 = 459 \text{ W/m}^2$$

$$J_1 = E_{b1} - q'_1 (1 - \varepsilon_1) \varepsilon_1 A'_1 = 5.67 \times 10^{-8} \text{ W/m}^2 \cdot \text{K}^4 (1200 \text{ K})^4 - 1213 \text{ W/m} [0.2/0.8\pi(0.005 \text{ m})]$$

$$J_1 = 98,268 \text{ W/m}^2.$$

Hence

$$q'_{1(\text{sur})} = \pi (0.005 \text{ m}) 0.375 (98,268 - 459) \text{ W/m}^2 = 576 \text{ W/m} \quad <$$

(d) Perform an energy balance on the reflector,

$$q'_{2i} = q'_{2o} + q'_{2,\text{conv}}$$

$$\frac{J_{2i} - E_{b2}}{(1 - \varepsilon_{2i})/\varepsilon_{2i}A'_2} = \frac{E_{b2} - J_{\text{sur}}}{(1 - \varepsilon_{2o})/\varepsilon_{2o}A'_2 + 1/A'_2 F_{2o(\text{sur})}} + 2\bar{h}_2 A'_2 (T_2 - T_\infty).$$

The radiosity of the reflector is

$$J_{2i} = J_1 - \frac{q'_{1(2i)}}{A'_1 F_{1(2i)}} = 98,268 \text{ W/m}^2 - \frac{(1213 - 576) \text{ W/m}}{\pi (0.005 \text{ m})(225/360)}$$

$$J_{2i} = 33,384 \text{ W/m}^2.$$

Hence

$$\frac{33,384 - 5.67 \times 10^{-8} (T_2^4)}{(0.9/0.1 \times 0.2 \text{ m})} = \frac{5.67 \times 10^{-8} (T_2^4) - 459}{(0.2/0.8 \times 0.2 \text{ m}) + (1/0.2 \text{ m} \times 1)} + 2 \times 0.4 (T_2 - 300)$$

$$741.9 - 0.126 \times 10^{-8} T_2^4 = 0.907 \times 10^{-8} T_2^4 - 73.4 + 0.8 T_2 - 240$$

$$1.033 \times 10^{-8} T_2^4 + 0.8 T_2 = 1005$$

which may be solved to yield

$$T_2 = 502 \text{ K} \quad <$$

**COMMENTS:** Choice of small  $\varepsilon_{2i}$  and large  $\varepsilon_{2o}$  insures that most of the radiation from heater is reflected to surroundings and reflector temperature remains low.

### PROBLEM 13.126

**KNOWN:** Geometrical conditions associated with tube array. Tube wall temperature and pressure of water flowing through tubes. Gas inlet velocity and temperature when heat is transferred from products of combustion in cross-flow, or temperature of electrically heated plates when heat is transferred by radiation from the plates.

**FIND:** (a) Steam production rate for gas flow without heated plates, (b) Steam production rate with heated plates and no gas flow, (c) Effects of inserting unheated plates with gas flow.

**SCHEMATIC:**

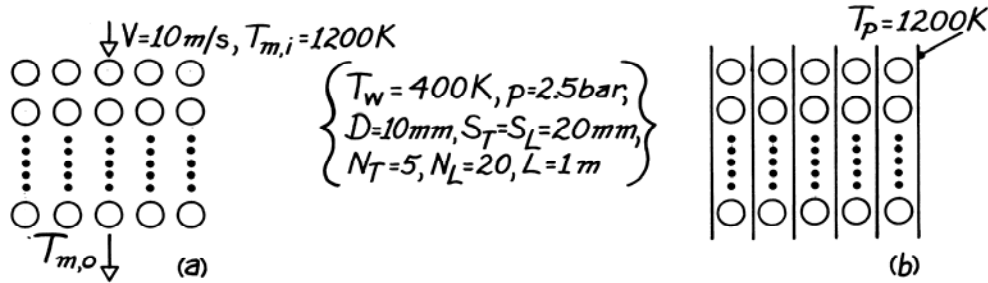

**ASSUMPTIONS:** (1) Steady-state conditions, (2) Negligible gas radiation, (3) Tube and plate surfaces may be approximated as blackbodies, (4) Gas outlet temperature is 600 K.

**PROPERTIES:** Table A-4, Air ( $\bar{T} = 900$  K, 1 atm):  $\rho = 0.387$  kg/m<sup>3</sup>,  $c_p = 1121$  J/kg·K,  $\nu = 102.9 \times 10^{-6}$  m<sup>2</sup>/s,  $k = 0.062$  W/m·K,  $Pr = 0.720$ ; (T = 400 K):  $Pr = 0.686$ ; (T = 1200 K):  $\rho = 0.29$  kg/m<sup>3</sup>; Table A-6, Sat. water (2.5 bars):  $h_{fg} = 2.18 \times 10^6$  J/kg.

**ANALYSIS:** (a) With

$$V_{\max} = [S_T / (S_T - D)] V = 20 \text{ m/s}$$

$$Re_D = \frac{V_{\max} D}{\nu} = \frac{20 \text{ m/s} (0.01 \text{ m})}{102.9 \times 10^{-6} \text{ m}^2/\text{s}} = 1944$$

and from the Zukauskas correlation of Chapter 7 with  $C_1 = 0.27$  and  $m = 0.63$ ,

$$\bar{Nu}_D = 0.27 (1944)^{0.63} (0.720)^{0.36} (0.720/0.686)^{1/4} = 28.7$$

$$\bar{h} = 0.062 \text{ W/m} \cdot \text{K} \times 28.7 / 0.01 \text{ m} = 178 \text{ W/m}^2 \cdot \text{K}.$$

The outlet temperature may be evaluated from

$$\frac{T_s - T_{m,o}}{T_s - T_{m,i}} = \exp\left(-\frac{\bar{h}A}{\dot{m}c_p}\right) = \exp\left(-\frac{\bar{h}N\pi D}{\rho V N_T S_T c_p}\right)$$

$$\frac{400 - T_{m,o}}{400 - 1200} = \exp\left(-\frac{178 \text{ W/m}^2 \cdot \text{K} \times 100 \times \pi \times 0.01 \text{ m}}{0.29 \text{ kg/m}^3 \times 10 \text{ m/s} \times 5 \times 0.02 \text{ m} \times 1121 \text{ J/kg} \cdot \text{K}}\right)$$

$$T_{m,o} = 543 \text{ K}.$$

Continued ...

**PROBLEM 13.126 (Cont.)**

With

$$\Delta T_{\ell m} = \frac{(T_s - T_{m,i}) - (T_s - T_{m,o})}{\ln[(T_s - T_{m,i}) / (T_s - T_{m,o})]} = \frac{-800 - (-143)}{\ln(800/143)} = -382 \text{ K}$$

find

$$q = \bar{h} A \Delta T_{\ell m} = 178 \text{ W/m}^2 \cdot \text{K} (100) \pi (0.01 \text{ m}) 1 \text{ m} (-382 \text{ K})$$

$$q = -214 \text{ kW.}$$

If the water enters and leaves as saturated liquid and vapor, respectively, it follows that  $-q = \dot{m} h_{fg}$ , hence

$$\dot{m} = \frac{214,000 \text{ W}}{2.18 \times 10^6 \text{ J/kg}} = 0.098 \text{ kg/s.} \quad <$$

(b) The radiation exchange between the plates and tube walls is

$$q = \left[ A_p F_{ps} \sigma (T_p^4 - T_s^4) \right] \cdot 2 \cdot N_T$$

where the factor of 2 is due to radiation transfer from two plates. The view factor and area are

$$F_{ps} = 1 - \left[ 1 - (D/S)^2 \right]^{1/2} + (D/S) \tan^{-1} \left[ \left( S^2 - D^2 \right) / D^2 \right]^{1/2}$$

$$F_{ps} = 1 - 0.866 + 0.5 \tan^{-1} 1.732 = 1 - 0.866 + 0.524$$

$$F_{ps} = 0.658$$

$$A_p = N_L \cdot S_L \cdot 1 \text{ m} = 20 \times 0.02 \text{ m} \times 1 \text{ m} = 0.40 \text{ m}^2.$$

Hence,

$$q = 5 \times \left[ 0.80 \text{ m}^2 \times 0.658 \times 5.67 \times 10^{-8} \text{ W/m}^2 \cdot \text{K}^4 (1200^4 - 400^4) \text{ K}^4 \right]$$

$$q = 305,440 \text{ W}$$

and the steam production rate is

$$\dot{m} = \frac{305,440 \text{ W}}{2.18 \times 10^6 \text{ J/kg}} = 0.140 \text{ kg/s.} \quad <$$

(c) The plate temperature is determined by an energy balance for which convection to the plate from the gas is equal to net radiation transfer from the plate to the tube. Conditions are complicated by the fact that the gas transfers energy to both the plate and the tubes, and its decay is not governed by a simple exponential. Insertion of the plates enhances heat transfer to the tubes and thereby increases the steam generation rate. However, for the prescribed conditions, the effect would be small, since in case (a), the heat transfer is already  $\approx 80\%$  of the maximum possible transfer.



### PROBLEM 13.127

**KNOWN:** Temperature and emissivity of ceramic plate which is separated from a glass plate of equivalent height and width by an air space. Temperature of air and surroundings on opposite side of glass. Spectral radiative properties of glass.

**FIND:** (a) Transmissivity of glass, (b) Glass temperature  $T_g$  and total heat rate  $q_h$ , (c) Effect of external forced convection on  $T_g$  and  $q_h$ .

**SCHEMATIC:**

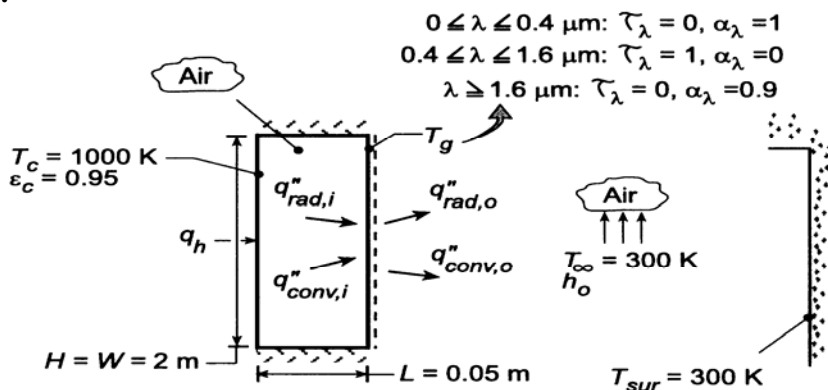

**ASSUMPTIONS:** (1) Spectral distribution of emission from ceramic approximates that of a blackbody, (2) Glass surface is diffuse, (3) Atmospheric air in cavity and ambient, (4) Cavity may be approximated as a two-surface enclosure with infinite parallel plates, (5) Glass is isothermal.

**PROPERTIES:** Table A-4, air ( $p = 1$  atm): Evaluated at  $\bar{T} = (T_c + T_g)/2$  and  $T_f = (T_g + T_\infty)/2$  using *IHT Properties Toolpad*.

**ANALYSIS:** (a) The total transmissivity of the glass is

$$\tau = \frac{\int_0^\infty \tau_\lambda E_{\lambda,b} d\lambda}{E_b} = \int_{\lambda_1=0.4\mu\text{m}}^{\lambda_2=1.6\mu\text{m}} (E_{\lambda,b} / E_b) d\lambda = F_{(0 \rightarrow \lambda_2)} - F_{(0 \rightarrow \lambda_1)}$$

With  $\lambda_2 T = 1600 \mu\text{m}\cdot\text{K}$  and  $\lambda_1 T = 400 \mu\text{m}\cdot\text{K}$ , respectively, Table 12.1 yields  $F_{(0 \rightarrow \lambda_2)} = 0.0197$  and  $F_{(0 \rightarrow \lambda_1)} = 0.0$ . Hence,

$$\tau = 0.0197$$

With so little transmission of radiation from the ceramic, the glass plate may be assumed to be opaque to a good approximation. Since more than 98% of the incident radiation is at wavelengths exceeding  $1.6 \mu\text{m}$ , for which  $\alpha_\lambda = 0.9$ ,  $\alpha_g \approx 0.9$ . Also, since  $T_g < T_c$ , nearly 100% of emission from the glass is at  $\lambda > 1.6 \mu\text{m}$ , for which  $\epsilon_\lambda = \alpha_\lambda = 0.9$ ,  $\epsilon_g = 0.9$  and the glass may be approximated as a gray surface.

(b) The glass temperature may be obtained from an energy balance of the form  $q''_{\text{conv},i} + q''_{\text{rad},i} = q''_{\text{conv},o} + q''_{\text{rad},o}$ . Using Eqs. 13.24 and 13.27 to evaluate  $q''_{\text{rad},i}$  and  $q''_{\text{rad},o}$ , respectively, it follows that

$$\bar{h}_i (T_c - T_g) + \frac{\sigma (T_c^4 - T_g^4)}{\frac{1}{\epsilon_c} + \frac{1}{\epsilon_g} - 1} = \bar{h}_o (T_g - T_\infty) + \epsilon_g \sigma (T_g^4 - T_{\text{sur}}^4)$$

Continued ...

### PROBLEM 13.127 (Cont.)

where, assuming  $10^4 \leq Ra_L \leq 10^7$ ,  $\bar{h}_i$  and  $\bar{h}_o$  are given by Eqs. 9.52 and 9.26, respectively,

$$\bar{h}_i = 0.42 \frac{k_i}{L} Ra_L^{1/4} Pr_i^{0.012} (H/L)^{-0.3}$$

$$\bar{h}_o = \frac{k_o}{H} \left\{ 0.825 + \frac{0.387 Ra_H^{1/6}}{\left[ 1 + (0.492 / Pr_o)^{9/16} \right]^{8/27}} \right\}^2$$

with  $Ra_L = g\beta_i (T_c - T_g)L^3/\nu_i\alpha_i$  and  $Ra_H = g\beta_o (T_g - T_\infty) H^3/\nu_o\alpha_o$ . Entering the energy balance into the *IHT* workspace and using the *Correlations*, *Properties* and *Radiation* Toolpads to evaluate the convection and radiation terms, the following result is obtained.

$$T_g = 825 \text{ K} \quad \leftarrow$$

The corresponding value of  $q_h$  is

$$q_h = 108 \text{ kW} \quad \leftarrow$$

where  $q_{\text{conv},i} = 3216 \text{ W}$ ,  $q_{\text{rad},i} = 104.7 \text{ kW}$ ,  $q_{\text{conv},o} = 15,190 \text{ W}$  and  $q_{\text{rad},o} = 92.8 \text{ kW}$ . The convection coefficients are  $\bar{h}_i = 4.6 \text{ W/m}^2 \cdot \text{K}$  and  $\bar{h}_o = 7.2 \text{ W/m}^2 \cdot \text{K}$ .

(c) For the prescribed range of  $\bar{h}_o$ , *IHT* was used to generate the following results.

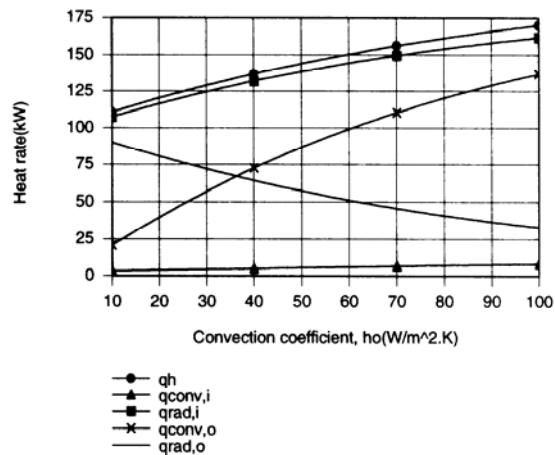
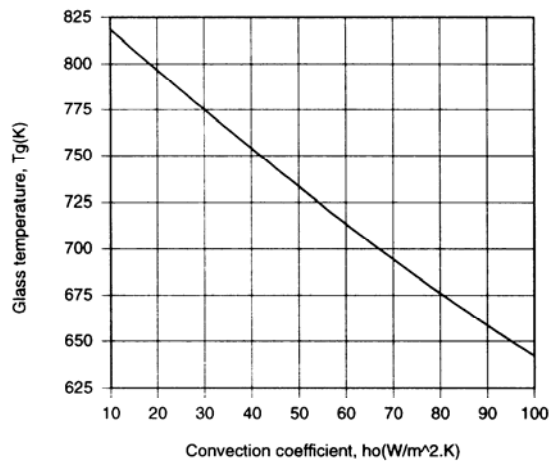

With increasing  $\bar{h}_o$ , the glass is cooled more effectively and  $T_g$  must decrease. With decreasing  $T_g$ ,  $q_{\text{conv},i}$ ,  $q_{\text{rad},i}$  and hence  $q_h$  must increase. Note that radiation makes the dominant contribution to heat transfer across the airspace. Although  $q_{\text{rad},o}$  decreases with decreasing  $T_g$ , the increase in  $q_{\text{conv},o}$  exceeds the reduction in  $q_{\text{rad},o}$ .

### PROBLEM 13.128

**KNOWN:** Spectral distribution of the absorption coefficient of pure solid silicon.

**FIND:** (a) The total absorption coefficient for pure solid silicon subject to irradiation from a source at the melting point temperature of silicon. (b) Estimates of the total transmissivity, total absorptivity and total emissivity of a  $L = 150 \mu\text{m}$  thick silicon sheet.

**ASSUMPTIONS:** (1) Irradiation from large surroundings, (2) Kirchoff's law assumed to be valid.

**PROPERTIES:** Table A-1, Silicon:  $T_f = 1685 \text{ K}$ .

**ANALYSIS:** Treating the irradiation from the large surroundings as black, we have

$$\begin{aligned} \kappa &= \frac{\int_0^\infty \kappa_\lambda G_\lambda(\lambda) d\lambda}{G} \approx \frac{\int_0^\infty \kappa_\lambda(\lambda) E_{\lambda,b}(\lambda, 1685 \text{ K}) d\lambda}{\int_0^\infty E_{\lambda,b}(\lambda, 1685 \text{ K}) d\lambda} \\ &= \kappa_{\lambda,1} F_{(0 \rightarrow 0.4 \mu\text{m})} + \kappa_{\lambda,2} F_{(0.4 \rightarrow 8 \mu\text{m})} + \kappa_{\lambda,3} F_{(8 \rightarrow 25 \mu\text{m})} + \kappa_{\lambda,4} F_{(25 \mu\text{m} \rightarrow \infty)} \end{aligned}$$

From Table 12.2,  $F_{(0 \rightarrow 0.4 \mu\text{m} \cdot 1685\text{K})} \approx 0$ ,  $F_{(0.4 \mu\text{m} \cdot 1685\text{K} \rightarrow 8 \mu\text{m} \cdot 1685\text{K})} = 0.955$ ,  $F_{(8 \mu\text{m} \cdot 1685\text{K} \rightarrow 15 \mu\text{m} \cdot 1685\text{K})} = 0.998 - 0.955 = 0.043$ ,  $F_{(15 \mu\text{m} \cdot 1685\text{K} \rightarrow \infty)} = 1 - 0.998 = 0.002$ . Therefore,

$$\kappa = (10^8 \text{ m}^{-1} \times 0) + (0 \text{ m}^{-1} \times 0.955) + (10^2 \text{ m}^{-1} \times 0.043) + (0 \text{ m}^{-1} \times 0.002) = 4.3 \text{ m}^{-1} \quad <$$

(b) The spectral transmissivity is  $\tau_\lambda = e^{-\kappa_\lambda L}$  which, for  $L = 150 \mu\text{m}$ , gives  $\tau_{\lambda,1} = 0$ ,  $\tau_{\lambda,2} = 1$ ,  $\tau_{\lambda,3} = 0.985$ ,  $\tau_{\lambda,4} = 1$ . Hence,

$$\tau = (0 \times 0) + (1 \times 0.955) + (0.985 \times 0.043) + (1 \times 0.002) = 0.999 \quad <$$

The total absorptivity is  $\alpha = 1 - \tau = 0.001$ , and the total emissivity is  $\varepsilon = \alpha = 0.001$ . <

**COMMENTS:** (1) Solid silicon is almost perfectly transparent to irradiation emanating from high temperature sources. It is a serious error to treat the solid material as opaque. (2) Liquid silicon can, however, be considered to be opaque, except for extremely small thicknesses. (3) *Dopants* are often added to silicon for semiconductor applications in order to tailor the electrical properties of the material. The presence of dopants can significantly increase the spectral absorption coefficients over the entire spectral range.

### PROBLEM 13.129

**KNOWN:** Conditions associated with a spherical furnace cavity.

**FIND:** Cooling rate needed to maintain furnace wall at a prescribed temperature.

**SCHEMATIC:**

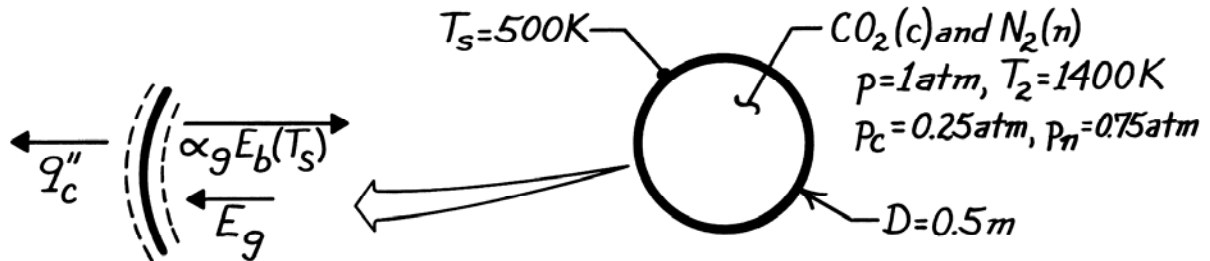

**ASSUMPTIONS:** (1) Steady-state, (2) Blackbody behavior for furnace wall, (3)  $N_2$  is non-radiating.

**ANALYSIS:** From an energy balance on a unit surface area of the furnace wall, the cooling rate per unit area must equal the absorbed irradiation from the gas ( $E_g$ ) minus the portion of the wall's emissive power absorbed by the gas

$$q_c'' = E_g - \alpha_g E_b(T_s)$$

$$q_c'' = \varepsilon_g \sigma T_g^4 - \alpha_g \sigma T_s^4$$

Hence, for the entire furnace wall,

$$q_c = A_s \sigma (\varepsilon_g T_g^4 - \alpha_g T_s^4)$$

The gas emissivity,  $\varepsilon_g$ , follows from the mean beam length of Table 13.4

$$L_e = 0.65D = 0.65 \times 0.5 \text{ m} = 0.325 \text{ m} = 1.066 \text{ ft.}$$

$$p_c L_e = 0.25 \text{ atm} \times 1.066 \text{ ft} = 0.267 \text{ ft} - \text{atm}$$

and from Fig. 13.18, find  $\varepsilon_g = \varepsilon_c = 0.09$ . From Eq. 13.42,

$$\alpha_g = \alpha_c = C_c \left( \frac{T_g}{T_s} \right)^{0.45} \times \varepsilon_c (T_s, p_c L_e [T_s / T_g])$$

With  $C_c = 1$  from Fig. 13.19,

$$\alpha_g = 1(1400/500)^{0.45} \times \varepsilon_c (500\text{K}, 0.095 \text{ ft} - \text{atm})$$

where, from Fig. 13.18,

$$\varepsilon_c (500\text{K}, 0.095 \text{ ft} - \text{atm}) = 0.067$$

Hence

$$\alpha_g = 1(1400/500)^{0.45} \times 0.067 = 0.106$$

and the heat rate is

$$q_c = \pi (0.5 \text{ m})^2 5.67 \times 10^{-8} \text{ W/m}^2 \cdot \text{K}^4 [0.09(1400 \text{ K})^4 - 0.106(500 \text{ K})^4]$$

$$q_c = 15.1 \text{ kW.}$$

<

### PROBLEM 13.130

**KNOWN:** Diameter and gas pressure, temperature and composition associated with a gas turbine combustion chamber.

**FIND:** Net radiative heat flux between the gas and the chamber surface.

**SCHEMATIC:**

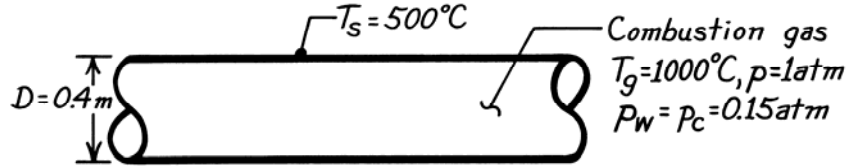

**ASSUMPTIONS:** (1) Steady-state conditions, (2) Blackbody behavior for chamber surface, (3) Remaining species are non-radiating, (4) Chamber may be approximated as an infinitely long tube.

**ANALYSIS:** From Eq. 13.40 the net rate of radiation transfer to the surface is

$$q_{\text{net}} = A_s \sigma \left( \epsilon_g T_g^4 - \alpha_g T_s^4 \right) \quad \text{or} \quad q'_{\text{net}} = \pi D \sigma \left( \epsilon_g T_g^4 - \alpha_g T_s^4 \right)$$

with  $A_s = \pi DL$ . From Table 13.4,  $L_e = 0.95D = 0.95 \times 0.4 \text{ m} = 0.380 \text{ m} = 1.25 \text{ ft}$ . Hence,  $p_w L_e = p_c L_e = 0.152 \text{ atm} \times 1.25 \text{ ft} = 0.187 \text{ atm-ft}$ .

$$\text{Fig. 13.16 } (T_g = 1273 \text{ K}), \rightarrow \epsilon_w \approx 0.069.$$

$$\text{Fig. 13.18 } (T_g = 1273 \text{ K}), \rightarrow \epsilon_c \approx 0.085.$$

$$\text{Fig. 13.20 } (p_w / (p_c + p_w) = 0.5, L_c (p_w + p_c) = 0.375 \text{ ft-atm}, T_g \geq 930^\circ\text{C}), \rightarrow \Delta\epsilon \geq 0.01.$$

From Eq. 13.38,

$$\epsilon_g = \epsilon_w + \epsilon_c - \Delta\epsilon = 0.069 + 0.085 - 0.01 \approx 0.144.$$

From Eq. 13.41 for the water vapor,

$$\alpha_w = C_w \left( T_g / T_s \right)^{0.45} \times \epsilon_w \left( T_s, p_w L_c \left[ T_s / T_g \right] \right)$$

where from Fig. 13.16 (773 K, 0.114 ft-atm),  $\rightarrow \epsilon_w \approx 0.083$ ,

$$\alpha_w = 1(1273/773)^{0.45} \times 0.083 = 0.104.$$

From Eq. 13.42, using Fig. 13.18 (773 K, 0.114 ft-atm),  $\rightarrow \epsilon_c \approx 0.08$ ,

$$\alpha_c = 1(1273/773)^{0.45} \times 0.08 = 0.100.$$

From Fig. 13.20, the correction factor for water vapor at carbon dioxide mixture,

$$\left( p_w / (p_c + p_w) = 0.1, L_e (p_w + p_c) = 0.375, T_g \approx 540^\circ\text{C} \right), \rightarrow \Delta\alpha \approx 0.004$$

and using Eq. 13.43

$$\alpha_g = \alpha_w + \alpha_c - \Delta\alpha = 0.104 + 0.100 - 0.004 \approx 0.200.$$

Hence, the heat rate is

$$q'_{\text{net}} = \pi (0.4 \text{ m}) 5.67 \times 10^{-8} \text{ W/m}^2 \cdot \text{K}^4 \left[ 0.144 (1273)^4 - 0.200 (773)^4 \right] = 21.9 \text{ kW/m.} <$$

### PROBLEM 13.131

**KNOWN:** Pressure, temperature and composition of flue gas in a long duct of prescribed diameter.

**FIND:** Net radiative flux to the duct surface.

**SCHEMATIC:**

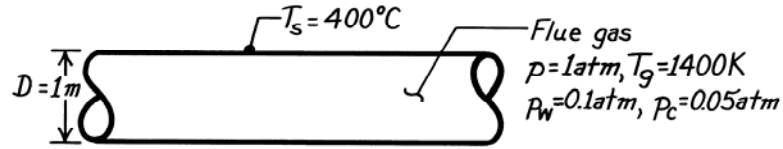

**ASSUMPTIONS:** (1) Steady-state conditions, (2) Duct surface behaves as a blackbody, (3) Other gases are non-radiating, (4) Flue may be approximated as an infinitely long tube.

**ANALYSIS:** With  $A_s = \pi DL$ , it follows from Eq. 13.40 that

$$q'_{\text{net}} = \pi D \sigma \left( \epsilon_g T_g^4 - \alpha_g T_s^4 \right)$$

From Table 13.4,  $L_e = 0.95D = 0.95 \times 1 \text{ m} = 0.95 \text{ m} = 3.12 \text{ ft}$ . Hence

$$p_w L_e = 0.12 \text{ atm} \times 3.12 \text{ m} = 0.312 \text{ atm-ft}$$

$$p_c L_e = 0.05 \text{ atm} \times 3.12 \text{ m} = 0.156 \text{ atm-ft}$$

With  $T_g = 1400 \text{ K}$ , Fig. 13.16  $\rightarrow \epsilon_w = 0.083$ ; Fig. 13.18  $\rightarrow \epsilon_c = 0.072$ . With  $p_w/(p_c + p_w) = 0.67$ ,  $L_e(p_w + p_c) = 0.468 \text{ atm-ft}$ ,  $T_g \geq 930^\circ\text{C}$ , Fig. 13.20  $\rightarrow \Delta\epsilon = 0.01$ . Hence from Eq. 13.38,

$$\epsilon_g = \epsilon_w + \epsilon_c - \Delta\epsilon = 0.083 + 0.072 - 0.01 = 0.145.$$

From Eq. 13.41,

$$\alpha_w = C_w \left( T_g / T_s \right)^{0.45} \times \epsilon_w \left( T_s, p_w L_e \left[ T_s / T_g \right] \right)$$

$$\alpha_w = 1 \left( 1400 / 400 \right)^{0.45} \times \epsilon_w \text{ Fig. 13.16} \rightarrow \epsilon_w \left( 400 \text{ K}, 0.0891 \text{ atm-ft} \right) = 0.1$$

$$\alpha_w = 0.176.$$

From Eq. 13.42,

$$\alpha_c = C_c \left( T_g / T_s \right)^{0.45} \times \epsilon_c \left( T_s, p_c L_e T_s / T_g \right)$$

$$\alpha_c = 1 \left( 1400 / 400 \right)^{0.45} \times \epsilon_c \text{ Fig. 13.18} \rightarrow \epsilon_c \left( 400 \text{ K}, 0.0891 \text{ atm-ft} \right) = 0.053$$

$$\alpha_c = 0.093.$$

With  $p_w/(p_c + p_w) = 0.67$ ,  $L_e(p_w + p_c) = 0.468 \text{ atm-ft}$ ,  $T_g \approx 125^\circ\text{C}$ , Fig. 13.20 gives  $\Delta\alpha \approx 0.003$ .

Hence from Eq. 13.43,

$$\alpha_g = \alpha_w + \alpha_c - \Delta\alpha = 0.176 + 0.093 - 0.003 = 0.266.$$

The heat rate per unit length is

$$q'_{\text{net}} = \pi (1 \text{ m}) 5.67 \times 10^{-8} \text{ W/m}^2 \cdot \text{K}^4 \left[ 0.145 (1400 \text{ K})^4 - 0.266 (400 \text{ K})^4 \right]$$

$$q'_{\text{net}} = 98 \text{ kW/m}.$$

<

### PROBLEM 13.132

**KNOWN:** Gas mixture of prescribed temperature, pressure and composition between large parallel plates of prescribed separation.

**FIND:** Net radiation flux to the plates.

**SCHEMATIC:**

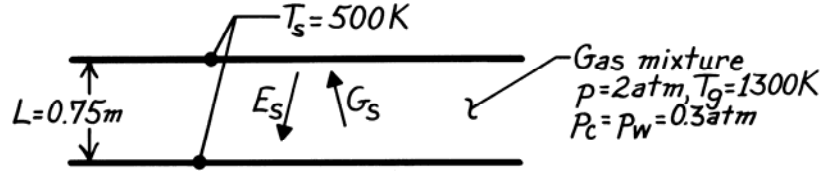

**ASSUMPTIONS:** (1) Steady-state conditions, (2) Furnace wall behaves as a blackbody, (3)  $\text{O}_2$  and  $\text{N}_2$  are non-radiating, (4) Negligible end effects.

**ANALYSIS:** The net radiative flux to a plate is

$$q''_{s,1} = G_s - E_s = \varepsilon_g \sigma T_g^4 - (1 - \tau_g) \sigma T_s^4$$

where  $G_s = \varepsilon_g \sigma T_g^4 + \tau_g E_s$ ,  $E_s = \sigma T_s^4$  and  $\tau_g = 1 - \alpha_g(T_s)$ . From Table 13.4,  $L_e = 1.8L = 1.8 \times 0.75\text{ m} = 1.35\text{ m} = 4.43\text{ ft}$ . Hence  $p_w L_e = p_c L_e = 1.33\text{ atm-ft}$ . From Figs. 3.16 and 3.18 find  $\varepsilon_w \approx 0.22$  and  $\varepsilon_c \approx 0.16$  for  $p = 1\text{ atm}$ . With  $(p_w + p)/2 = 1.15\text{ atm}$ , Fig. 13.17 yields  $C_w \approx 1.40$  and from Fig. 13.19,  $C_c \approx 1.08$ . Hence, the gas emissivities are

$$\varepsilon_w = C_w \varepsilon_w(1\text{ atm}) \approx 1.40 \times 0.22 = 0.31 \quad \varepsilon_c = C_c \varepsilon_c(1\text{ atm}) \approx 1.08 \times 0.16 = 0.17.$$

From Fig. 13.20 with  $p_w/(p_c + p_w) = 0.5$ ,  $L_e(p_c + p_w) = 2.66\text{ atm-ft}$  and  $T_g > 930^\circ\text{C}$ ,  $\Delta\varepsilon \approx 0.047$ . Hence, from Eq. 13.38,

$$\varepsilon_g = \varepsilon_w + \varepsilon_c - \Delta\varepsilon \approx 0.31 + 0.17 - 0.047 \approx 0.43.$$

To evaluate  $\alpha_g$  at  $T_s$ , use Eq. 13.43 with

$$\alpha_w = C_w \left( T_g / T_s \right)^{0.45} \varepsilon_w \left( T_s, p_w L_e T_s / T_g \right) = C_w (1300/500)^{0.45} \varepsilon_w(500, 0.51)$$

$$\alpha_w \approx 1.40 (1300/500)^{0.45} 0.22 = 0.47$$

$$\alpha_c = C_c (1300/500)^{0.45} \varepsilon_c(500, 0.51) \approx 1.08 (1300/500)^{0.45} 0.11 = 0.18.$$

From Fig. 13.20, with  $T_g \approx 125^\circ\text{C}$  and  $L_e(p_w + p_c) = 2.66\text{ atm-ft}$ ,  $\Delta\alpha = \Delta\varepsilon \approx 0.024$ . Hence

$$\alpha_g = \alpha_w + \alpha_c - \Delta\alpha \approx 0.47 + 0.18 - 0.024 \approx 0.63 \quad \text{and} \quad \tau_g = 1 - \alpha_g \approx 0.37.$$

Hence, the heat flux from Eq. (1) is

$$q''_{s,1} = 0.43 \times 5.67 \times 10^{-8} \text{ W/m}^2 \cdot \text{K}^4 (1300\text{ K})^4 - 0.63 \times 5.67 \times 10^{-8} \text{ W/m}^2 \cdot \text{K}^4 (500\text{ K})^4$$

$$q''_{s,1} \approx 67.4 \text{ kW/m}^2.$$

The net radiative flux to both plates is then  $q''_{s,2} \approx 134.8 \text{ kW/m}^2$ . <

### PROBLEM 13.133

**KNOWN:** Flow rate, temperature, pressure and composition of exhaust gas in pipe of prescribed diameter. Velocity and temperature of external coolant.

**FIND:** Pipe wall temperature and heat flux.

**SCHEMATIC:**

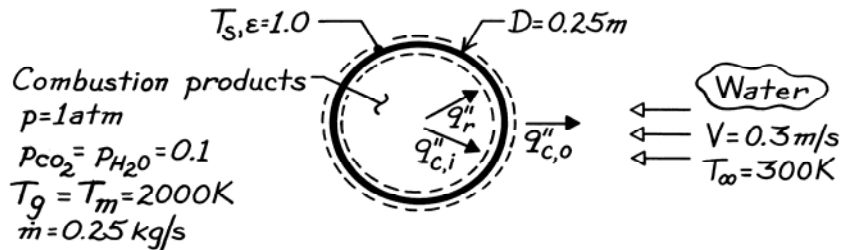

**ASSUMPTIONS:** (1)  $L/D \gg 1$  (infinitely long pipe), (2) Negligible axial gradient for gas temperature, (3) Gas is in fully developed flow, (4) Gas thermophysical properties are those of air, (5) Negligible pipe wall thermal resistance, (6) Negligible pipe wall emission.

**PROPERTIES:** Table A-4: Air ( $T_m = 2000 \text{ K}$ , 1 atm):  $\rho = 0.174 \text{ kg/m}^3$ ,  $\mu = 689 \times 10^{-7} \text{ kg/m}\cdot\text{s}$ ,  $k = 0.137 \text{ W/m}\cdot\text{K}$ ,  $\text{Pr} = 0.672$ ; Table A-6: Water ( $T_\infty = 300 \text{ K}$ ):  $\rho = 997 \text{ kg/m}^3$ ,  $\mu = 855 \times 10^{-6} \text{ kg/s}\cdot\text{m}$ ,  $k = 0.613 \text{ W/m}\cdot\text{K}$ ,  $\text{Pr} = 5.83$ .

**ANALYSIS:** Performing an energy balance for a control surface about the pipe wall,

$$q_r'' + q_{c,i}'' = q_{c,o}''$$

$$\epsilon_g \sigma T_g^4 + h_i (T_m - T_s) = \bar{h}_o (T_s - T_\infty)$$

The gas emissivity is

$$\epsilon_g = \epsilon_w + \epsilon_c - \Delta\epsilon$$

where

$$L_e = 0.95D = 0.238 \text{ m} = 0.799 \text{ ft}$$

$$p_c L_e = p_w L_e = 0.1 \text{ atm} \times 0.238 \text{ m} = 0.0238 \text{ atm}\cdot\text{m} = 0.0779 \text{ atm}\cdot\text{ft}$$

and from Fig. 13.16  $\rightarrow \epsilon_w \approx 0.017$ ; Fig. 13.18  $\rightarrow \epsilon_c \approx 0.031$ ; Fig. 13.20  $\rightarrow \Delta\epsilon \approx 0.001$ . Hence  $\epsilon_g = 0.047$ . Estimating the *internal flow convection coefficient*, find

$$\text{Re}_D = \frac{4 \dot{m}}{\pi D \mu} = \frac{4 \times 0.25 \text{ kg/s}}{\pi (0.25 \text{ m}) 689 \times 10^{-7} \text{ kg/m}\cdot\text{s}} = 18,480$$

and for turbulent flow, we may use the Dittus-Boelter correlation of Chapter 8,

$$\text{Nu}_D = 0.023 \text{Re}_D^{4/5} \text{Pr}^{0.3} = 0.023 (18,480)^{4/5} (0.672)^{0.3} = 52.9$$

$$h_i = \text{Nu}_D \frac{k}{D} = 52.9 \frac{0.137 \text{ W/m}\cdot\text{K}}{0.25 \text{ m}} = 29.0 \text{ W/m}^2\cdot\text{K}$$

Continued ...



### PROBLEM 13.133 (Cont.)

Estimating the *external convection coefficient*, find

$$\text{Re}_D = \frac{\rho V D}{\mu} = \frac{997 \text{ kg/m}^3 \times 0.3 \text{ m/s} \times 0.25 \text{ m}}{855 \times 10^{-6} \text{ kg/s} \cdot \text{m}} = 87,456.$$

Hence, using the Zukauskas correlation of Chapter 7,

$$\overline{\text{Nu}}_D = 0.26 \text{Re}_D^{0.6} \text{Pr}^{0.37} (\text{Pr}/\text{Pr}_s)^{1/4}.$$

Assuming  $\text{Pr}/\text{Pr}_s \approx 1$ ,

$$\overline{\text{Nu}}_D = 0.26(87,456)^{0.6} (5.83)^{0.37} = 461$$

$$\bar{h}_o = \overline{\text{Nu}}_D (k/D) = 461(0.613 \text{ W/m} \cdot \text{K} / 0.25 \text{ m}) = 1129 \text{ W/m}^2 \cdot \text{K}.$$

Substituting numerical values in the energy balance, find

$$\begin{aligned} 0.047 \times 5.67 \times 10^{-8} \text{ W/m}^2 \cdot \text{K}^4 (2000 \text{ K})^4 + 29 \text{ W/m}^2 \cdot \text{K} (2000 - T_s) \text{ K} \\ = 1129 \text{ W/m}^2 \cdot \text{K} (T_s - 300) \text{ K} \end{aligned}$$

$$T_s = 380 \text{ K.} \quad <$$

The heat flux due to convection is

$$q''_{c,i} = h_i (T_m - T_s) = 29 \text{ W/m}^2 \cdot \text{K} (2000 - 379.4) \text{ K} = 46,997 \text{ W/m}^2$$

and the total heat flux is

$$q''_s = q''_r + q''_{c,i} = 42,638 + 46,997 = 89,640 \text{ W/m}^2. \quad <$$

**COMMENTS:** Contributions of gas radiation and convection to the wall heat flux are approximately the same. Small value of  $T_s$  justifies neglecting emission from the pipe wall to the gas.  $\text{Pr}_s = 1.62$  for  $T_s = 380 \rightarrow (\text{Pr}/\text{Pr}_s)^{1/4} = 1.38$ . Hence the value of  $\bar{h}_o$  should be corrected. The value would  $\uparrow$ , and  $T_s$  would  $\downarrow$ .

### PROBLEM 13.134

**KNOWN:** Flow rate, temperature, pressure and composition of combustion gas that is subsequently mixed with saturated steam of known flow rate.

**FIND:** Gas emission to a pipe wall with and without steam injection.

**ASSUMPTIONS:** (1) Gas thermophysical properties and molecular weight same as air, (2) ideal gas mixture.

**ANALYSIS:** The mass flow rate without steam injection is  $\dot{m}_1 = 0.25 \text{ kg/s}$ . The mass flow rate of water vapor in the original mixture is  $\dot{m}_1 m_{w1}$  where  $m_{w1}$  is the mass fraction of water vapor,

$$\begin{aligned} m_{w1} &= p_{w1} \mathcal{M}_w / p \mathcal{M}_{\text{air}} \\ &= 0.1 \text{ atm} \times 18 \text{ kg/kmol} / (1 \text{ atm} \times 29 \text{ kg/kmol}) \\ &= 0.0621 \end{aligned}$$

Thus the mass flow rate of the injected steam is

$$\dot{m}_s = 0.5 \dot{m}_1 m_{w1} = 0.5 \times 0.25 \text{ kg/s} \times 0.0621 = 0.00776 \text{ kg/s}$$

and the total mass flow rate after injection is  $\dot{m}_2 = \dot{m}_1 + \dot{m}_s = 0.2578 \text{ kg/s}$ . Treating the gases as ideal with properties of air, an energy balance on the mixing of the combustion products and injected steam yields

$$\dot{m}_1 T_{g1} + \dot{m}_w T_{w1} = \dot{m}_2 T_g ; T_g = \frac{\dot{m}_1 T_{g1} + \dot{m}_w T_{w1}}{\dot{m}_2} = \frac{0.25 \text{ kg/s} \times 2000 \text{ K} + 0.0076 \text{ kg/s} \times 373 \text{ K}}{0.2578 \text{ kg/s}} = 1951 \text{ K}$$

The gas emissivity is  $\varepsilon_g = \varepsilon_w + \varepsilon_c - \Delta\varepsilon$  where  $L_e = 0.95 D = 0.238 \text{ m} = 0.799 \text{ ft}$ . The partial pressures of the gases are obtained by accounting for the additional water vapor in the pipe relative to Problem 13.133.

$$p_{w2} = x_{w2} p = \frac{x_{w1} + 0.5x_{w1}}{1 + 0.5x_{w1}} p = \frac{0.15}{1.05} p = 0.143 \text{ atm}$$

where  $x_{w2}$  is the mole fraction of water in the final mixture. Similarly,

$$p_{c2} = \frac{x_{c1}}{1 + 0.5x_{w1}} p = \frac{0.1}{1.05} p = 0.0952 \text{ atm}$$

The products of the partial pressures and mean beam lengths are therefore

$$p_c L_e = 0.095 \text{ atm} \times 0.799 \text{ ft} = 0.076 \text{ atm-ft} ; p_w L_e = 0.143 \text{ atm} \times 0.799 \text{ ft} = 0.114 \text{ atm-ft}$$

From Fig. 13.15,  $\varepsilon_w \approx 0.025$ . From Fig. 13.17,  $\varepsilon_c \approx 0.034$ . From Fig. 13.19,  $\Delta\varepsilon \approx 0.002$ . Hence,  $\varepsilon_g = 0.025 + 0.034 - 0.002 = 0.057$  and the emission from the gas to the pipe wall is

$$E_g = \varepsilon_g \sigma T_g^4 = 0.057 \times 5.67 \times 10^{-8} \text{ W/m}^2 \cdot \text{K}^4 \times (1951 \text{ K})^4 = 46,800 \text{ W/m}^2 \quad <$$

Continued...

### PROBLEM 13.134 (Cont.)

Without injection, the partial pressures are  $p_w = p_c = 0.1$  atm and the partial pressure – mean beam length products are  $p_c L_e = p_w L_e = 0.10$  atm  $\times$  0.799 ft = 0.080 atm-ft yielding from Fig. 13.15,  $\varepsilon_w \approx 0.017$ . From Fig. 13.17,  $\varepsilon_c \approx 0.031$ . From Fig. 13.19,  $\Delta\varepsilon \approx 0.001$ . Hence,  $\varepsilon_g = 0.047$  and the emission from the gas to the pipe wall is

$$E_g = \varepsilon_g \sigma T_g^4 = 0.047 \times 5.67 \times 10^{-8} \text{ W/m}^2 \cdot \text{K}^4 \times (2000 \text{ K})^4 = 42,600 \text{ W/m}^2 \quad <$$

**COMMENTS:** (1) The gas emissivity is increased significantly with steam injection, but the temperature of the hot gas is reduced due to mixing with the relatively cool steam. The net effect is a modest increase in radiation heat flux to the pipe surface. Injection of a greater amount of steam results in even higher gas emissivities, but the effect is offset by even lower gas temperatures. (2) Injection of *liquid* water would further reduce the gas temperature as the latent heat of vaporization of the water is accounted for. (3) The results are highly dependent upon the accuracy with which one can read the figures in the text. (4) Water vapor properties are taken to be the same as those of air. (5) A more detailed analysis would be appropriate if the scheme were to be considered seriously.

### PROBLEM 13.135

**KNOWN:** Flowrate, composition and temperature of flue gas passing through inner tube of an annular waste heat boiler. Boiler dimensions. Steam pressure.

**FIND:** Rate at which saturated liquid can be converted to saturated vapor,  $\dot{m}_s$ .

**SCHEMATIC:**

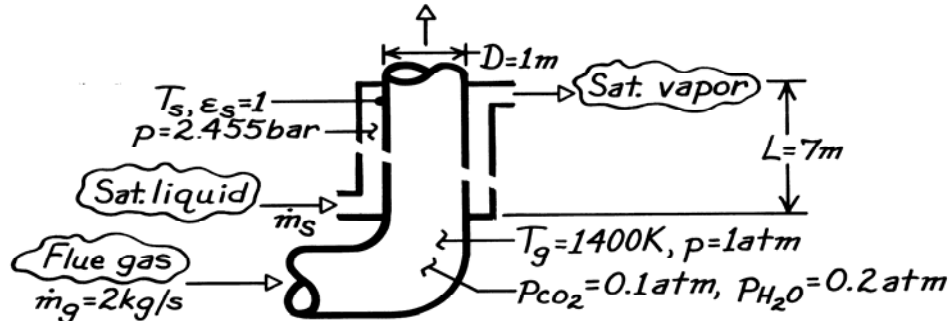

**ASSUMPTIONS:** (1) Inner wall is thin and steam side convection coefficient is very large; hence  $T_s = T_{\text{sat}}(2.455 \text{ bar})$ , (2) For calculation of gas radiation, inner tube is assumed infinitely long and gas is approximated as isothermal at  $T_g$ .

**PROPERTIES:** Flue gas (given):  $\mu = 530 \times 10^{-7} \text{ kg/s}\cdot\text{m}$ ,  $k = 0.091 \text{ W/m}\cdot\text{K}$ ,  $\text{Pr} = 0.70$ ; Table A-6, Saturated water (2.455 bar):  $T_s = 400 \text{ K}$ ,  $h_{fg} = 2183 \text{ kJ/kg}$ .

**ANALYSIS:** The steam generation rate is

$$\dot{m}_s = q / h_{fg} = (q_{\text{conv}} + q_{\text{rad}}) / h_{fg}$$

where

$$q_{\text{rad}} = A_s \sigma (\epsilon_g T_g^4 - \alpha_g T_s^4)$$

with

$$\epsilon_g = \epsilon_w + \epsilon_c - \Delta\epsilon \quad \alpha_g = \alpha_w + \alpha_c - \Delta\alpha.$$

From Table 13.4, find  $L_e = 0.95D = 0.95 \text{ m} = 3.117 \text{ ft}$ . Hence

$$p_w L_e = 0.2 \text{ atm} \times 3.117 \text{ ft} = 0.623 \text{ ft}\cdot\text{atm}$$

$$p_c L_e = 0.1 \text{ atm} \times 3.117 \text{ ft} = 0.312 \text{ ft}\cdot\text{atm}.$$

From Fig. 13.16, find  $\epsilon_w \approx 0.13$  and Fig. 13.18 find  $\epsilon_c \approx 0.095$ . With  $p_w/(p_c + p_w) = 0.67$  and  $L_e(p_w + p_c) = 0.935 \text{ ft}\cdot\text{atm}$ , from Fig. 13.20 find  $\Delta\epsilon \approx 0.036 \approx \Delta\alpha$ . Hence  $\epsilon_g \approx 0.13 + 0.095 - 0.036 = 0.189$ .

Also, with  $p_w L_e (T_s/T_g) = 0.2 \text{ atm} \times 0.95 \text{ m} (400/1400) = 0.178 \text{ ft}\cdot\text{atm}$  and  $T_s = 400 \text{ K}$ , Fig. 13.16 yields  $\epsilon_w \approx 0.14$ . With  $p_c L_e (T_s/T_g) = 0.1 \text{ atm} \times 0.95 \text{ m} (400/1400) = 0.089 \text{ ft}\cdot\text{atm}$  and  $T_s = 400 \text{ K}$ , Fig. 13.18 yields  $\epsilon_c \approx 0.067$ . Hence

$$\alpha_w = (T_g/T_s)^{0.45} \epsilon_w (T_s, p_w L_e T_s/T_g)$$

$$\alpha_w = (1400/400)^{0.45} 0.14 = 0.246$$

and

$$\alpha_c = (T_g/T_s)^{0.65} \epsilon_c (T_s, p_c L_e T_s/T_g)$$

Continued ...

**PROBLEM 13.135 (Cont.)**

$$\alpha_c = (1400/400)^{0.65} 0.067 = 0.151$$

$$\alpha_g = 0.246 + 0.151 - 0.036 = 0.361.$$

Hence

$$q_{\text{rad}} = \pi(1 \text{ m})7 \text{ m} \times 5.67 \times 10^{-8} \text{ W/m}^2 \cdot \text{K}^4 \left[ 0.189(1400 \text{ K})^4 - 0.361(400 \text{ K})^4 \right]$$

$$q_{\text{rad}} = (905.3 - 11.5) \text{ kW} = 893.8 \text{ kW}.$$

For convection,

$$q_{\text{conv}} = \bar{h}\pi DL(T_g - T_s)$$

with

$$\text{Re}_D = \frac{4\dot{m}}{\pi D\mu} = \frac{4 \times 2 \text{ kg/s}}{\pi \times 1 \text{ m} \times 530 \times 10^{-7} \text{ kg/s} \cdot \text{m}} = 48,047$$

and assuming fully developed turbulent flow throughout the tube, the Dittus-Boelter correlation of Chapter 8 gives

$$\overline{\text{Nu}}_D = 0.023 \text{Re}_D^{4/5} \text{Pr}^{0.3} = 0.023(48,047)^{4/5} (0.70)^{0.3} = 115$$

$$\bar{h} = (k/D)\overline{\text{Nu}}_D = (0.091 \text{ W/m} \cdot \text{K}/1 \text{ m})115 = 10.5 \text{ W/m}^2 \cdot \text{K}.$$

Hence

$$q_{\text{conv}} = 10.5 \text{ W/m}^2 \cdot \text{K} \pi(1 \text{ m})7 \text{ m}(1400 - 400) \text{ K} = 230.1 \text{ kW}$$

and the vapor production rate is

$$\dot{m}_s = \frac{q}{h_{fg}} = \frac{(893.8 + 230.1) \text{ kW}}{2183 \text{ kJ/kg}} = \frac{1123.9 \text{ kW}}{2183 \text{ kJ/kg}}$$

$$\dot{m}_s = 0.515 \text{ kg/s}.$$

<

**COMMENTS:** (1) Heat transfer is dominated by radiation, which is typical of heat recovery devices having a large gas volume. (2) A more detailed analysis would account for radiation exchange involving the ends (upstream and downstream) of the inner tube. (3) Using a representative specific heat of  $c_p = 1.2 \text{ kJ/kg} \cdot \text{K}$ , the temperature drop of the gas passing through the tube would be  $\Delta T_g = 1123.9 \text{ kW}/(2 \text{ kg/s} \times 1.2 \text{ kJ/kg} \cdot \text{K}) = 468 \text{ K}$ .

### PROBLEM 13.136

**KNOWN:** Wet newsprint moving through a drying oven.

**FIND:** Required evaporation rate, air velocity and oven temperature.

**SCHEMATIC:**

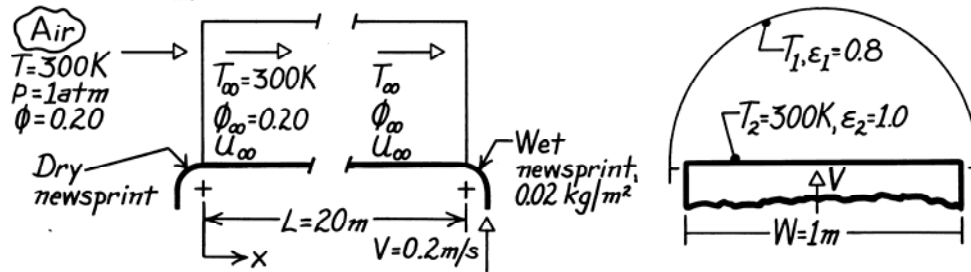

**ASSUMPTIONS:** (1) Steady-state conditions, (2) Negligible freestream turbulence, (3) Heat and mass transfer analogy applicable, (4) Oven and newsprint surfaces are diffuse gray, (5) Oven end effects negligible.

**PROPERTIES:** Table A-6, Water vapor (300 K, 1 atm):  $\rho_{\text{sat}} = 1/v_g = 0.0256 \text{ kg/m}^3$ ,  $h_{\text{fg}} = 2438 \text{ kJ/kg}$ ; Table A-4, Air (300 K, 1 atm):  $\nu = 15.89 \times 10^{-6} \text{ m}^2/\text{s}$ ; Table A-8, Water vapor-air (300 K, 1 atm):  $D_{\text{AB}} = 0.26 \times 10^{-4} \text{ m}^2/\text{s}$ ,  $S_c = \nu/D_{\text{AB}} = 0.611$ .

**ANALYSIS:** The evaporation rate required to completely dry the newsprint having a water content of  $m''_{\text{A}} = 0.02 \text{ kg/m}^2$  as it enters the oven ( $x = L$ ) follows from a species balance on the newsprint.

$$\dot{M}_{\text{A},\text{in}} - \dot{M}_{\text{A},\text{out}} = \dot{M}_{\text{st}}$$

$$\dot{M}_{\text{L}} - \dot{M}_0 - \dot{M}_{\text{A},\text{s}} = 0.$$

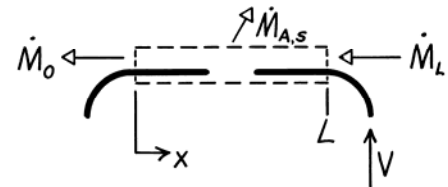

The rate at which moisture enters in the newsprint is

$$\dot{M}_{\text{L}} = m''_{\text{A}} VW$$

hence,

$$\dot{M}_{\text{A},\text{s}} = m''_{\text{A}} VW = 0.02 \text{ kg/m}^2 \times 0.2 \text{ m/s} \times 1 \text{ m} = 4 \times 10^{-3} \text{ kg/s.} \quad <$$

The required velocity of the airstream through the oven,  $u_{\infty}$ , can be determined from a convection analysis. From the rate equation,

$$\dot{M}_{\text{A},\text{s}} = \bar{h}_m WL (\rho_{\text{A},\text{s}} - \rho_{\text{A},\infty}) = \bar{h}_m WL \rho_{\text{A},\text{sat}} (1 - \phi_{\infty})$$

$$\bar{h}_m = \dot{M}_{\text{A},\text{s}} / WL \rho_{\text{A},\text{sat}} (1 - \phi_{\infty})$$

$$\bar{h}_m = 4 \times 10^{-3} \text{ kg/s} / 1 \text{ m} \times 20 \text{ m} \times 0.0256 \text{ kg/m}^3 (1 - 0.2) = 9.77 \times 10^{-3} \text{ m/s.}$$

Now determine what flow velocity is required to produce such a coefficient. Assume flow over a flat plate with

$$\overline{\text{Sh}}_{\text{L}} = \bar{h}_m L / D_{\text{AB}} = 9.77 \times 10^{-3} \text{ m/s} \times 20 \text{ m} / 0.26 \times 10^{-4} \text{ m}^2/\text{s} = 7515$$

Continued ...

**PROBLEM 13.136 (Cont.)**

and, from Section 7.2.1 for laminar flow

$$\text{Re}_L = \left[ \overline{\text{Sh}}_L / 0.664 \text{Sc}^{1/3} \right]^2 = \left[ 7515 / 0.664 (0.611)^{1/3} \right]^2 = 1.78 \times 10^8.$$

However, since  $\text{Re}_L > \text{Re}_{Lc} = 5 \times 10^5$ , the flow must be turbulent. Using the correlation for mixed laminar and turbulent flow conditions from Section 7.2.3, find

$$\text{Re}_L^{4/5} = \left[ \overline{\text{Sh}}_L / \text{Sc}^{1/3} + 871 \right] / 0.037$$

$$\text{Re}_L^{4/5} = \left[ 7515 / (0.611)^{1/3} + 871 \right] / 0.037$$

$$\text{Re}_L = 5.95 \times 10^6$$

noting  $\text{Re}_L > \text{Re}_{Lc}$ . Recognize that  $u_\infty^*$  is the velocity relative to the newspaper,

$$u_\infty^* = \text{Re}_L \nu / L = 5.95 \times 10^6 \times 15.89 \times 10^{-6} \text{ m}^2 / \text{s} / 20 \text{ m} = 4.73 \text{ m/s}.$$

The air velocity relative to the oven will be,

$$u_\infty = u_\infty^* - V = (4.73 - 0.2) \text{ m/s} = 4.53 \text{ m/s}.$$

The temperature required of the oven surface follows from an energy balance on the newspaper. Find

$$\dot{E}_{\text{in}} - \dot{E}_{\text{out}} = 0$$

$$q_{\text{rad}} - q_{\text{evap}} = 0$$

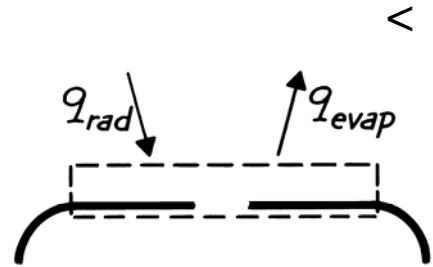

where

$$q_{\text{evap}} = \dot{M}_{A,s} h_{fg} = 4.0 \times 10^{-3} \text{ kg/s} \times 2438 \times 10^3 \text{ J/kg} = 9752 \text{ W}$$

and the radiation exchange is that for a two surface enclosure, Eq. 13.23,

$$q_{\text{rad}} = \frac{\sigma (T_1^4 - T_2^4)}{(1 - \epsilon_1) / \epsilon_1 A_1 + 1 / A_1 F_{12} + (1 - \epsilon_2) / \epsilon_2 A_2}.$$

Evaluate,

$$A_1 = \pi / 2 \text{ WL}, \quad A_2 = \text{WL}, \quad F_{21} = 1, \quad \text{and} \quad A_1 F_{12} = A_2 F_{21} = \text{WL}$$

hence, with  $\epsilon_1 = 0.8$ ,

$$q_{\text{rad}} = \sigma \text{WL} (T_1^4 - T_2^4) / [(1/2\pi) + 1]$$

$$T_1^4 = T_2^4 + q_{\text{rad}} [(1/2\pi) + 1] / \sigma \text{WL}$$

$$T_1^4 = (300 \text{ K})^4 + 9752 \text{ W} [(1/2\pi + 1)] / 5.67 \times 10^{-8} \text{ W/m}^2 \cdot \text{K}^4 \times 1 \text{ m} \times 20 \text{ m}$$

$$T_1 = 367 \text{ K}.$$

**COMMENTS:** Note that there is no convection heat transfer since  $T_\infty = T_s = 300 \text{ K}$ .

### PROBLEM 13.137

**KNOWN:** Configuration of grain dryer. Emissivities of grain bed and heater surface. Temperature of grain.

**FIND:** (a) Temperature of heater required for specified drying rate, (b) Convection mass transfer coefficient required to sustain evaporation, (c) Validity of assuming negligible convection heat transfer.

**SCHEMATIC:**

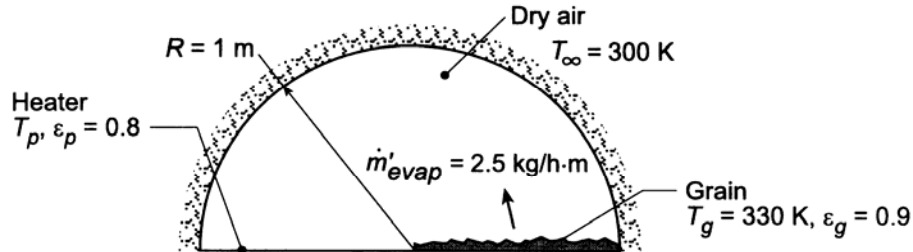

**ASSUMPTIONS:** (1) Diffuse/gray surfaces, (2) Oven wall is a reradiating surface, (3) Negligible convection heat transfer, (4) Applicability of heat/mass transfer analogy, (5) Air is dry.

**PROPERTIES:** Table A-6, saturated water ( $T = 330 \text{ K}$ ):  $v_g = 8.82 \text{ m}^3/\text{kg}$ ,  $h_{fg} = 2.366 \times 10^6 \text{ J/kg}$ . Table A-4, air (assume  $T \approx 300 \text{ K}$ ):  $\rho = 1.614 \text{ kg/m}^3$ ,  $c_p = 1007 \text{ J/kg}\cdot\text{K}$ ,  $\alpha = 22.5 \times 10^{-6} \text{ m}^2/\text{s}$ . Table A-8,  $\text{H}_2\text{O}(\text{v}) - \text{air}$  ( $T = 298 \text{ K}$ ):  $D_{AB} = 0.26 \times 10^{-4} \text{ m}^2/\text{s}$ .

**ANALYSIS:** (a) Neglecting convection, the energy required for evaporation must be supplied by net radiation transfer from the heater plate to the grain bed. Hence,

$$q'_{\text{rad}} = \dot{m}'_{\text{evap}} h_{fg} = (2.5 \text{ kg/h}\cdot\text{m}) \left( 2.366 \times 10^6 \text{ J/kg} \right) / 3600 \text{ s/h} = 1643 \text{ W/m}$$

where  $q'_{\text{rad}}$  is given by Eq. 13.30. With  $A'_p = A'_g \equiv A'$ ,

$$q'_{\text{rad}} = \frac{A' (E_{bp} - E_{bg})}{\frac{1 - \epsilon_p}{\epsilon_p} + \frac{1}{F_{pg} + \left[ \left( \frac{1}{F_{pR}} \right) + \left( \frac{1}{F_{gR}} \right) \right]^{-1}}} + \frac{1 - \epsilon_g}{\epsilon_g}$$

where  $A' = R = 1 \text{ m}$ ,  $F_{pg} = 0$  and  $F_{pR} = F_{gR} = 1$ . Hence,

$$q'_{\text{rad}} = \frac{\sigma (T_p^4 - 320^4)}{0.25 + 2 + 0.111} = 2.40 \times 10^{-8} (T_p^4 - 320^4) = 1643 \text{ W/m}$$

$$2.40 \times 10^{-8} T_p^4 - 2518 = 1643$$

$$T_p = 530 \text{ K}$$

<

(b) The evaporation rate is given by Eq. 6.12, and with  $A'_s = 1 \text{ m}$ ,  $n'_A = \dot{m}'_{\text{evap}}$ , and  $\rho_{A,\infty} = 0$ ,

Continued ...



**PROBLEM 13.137 (Cont.)**

$$h_m = \frac{n'_A}{A'_s \rho_{A,s}} = \frac{n'_A v_g}{A'_s} = \frac{2.5 \text{ kg/h} \cdot \text{m}}{1 \text{ m}} \times \frac{1}{3600 \text{ s}} \times 8.82 \frac{\text{m}^3}{\text{kg}} = 6.13 \times 10^{-3} \text{ m/s}$$

<

(c) From the heat and mass transfer analogy, Eq. 6.60,

$$h = h_m \rho c_p \text{Le}^{2/3}$$

where  $\text{Le} = \alpha/D_{AB} = 22.5/26.0 = 0.865$ . Hence

$$h = 6.13 \times 10^{-3} \text{ m/s} (1.161 \text{ kg/m}^3) 1007 \text{ J/kg} \cdot \text{K} (0.865)^{2/3} = 6.5 \text{ W/m}^2 \cdot \text{K}.$$

The corresponding convection heat transfer rate is

$$q'_{\text{conv}} = hA'(T_g - T_\infty) = 6.5 \text{ W/m}^2 \cdot \text{K} (1 \text{ m}) (330 - 300) \text{ K} = 195 \text{ W/m}$$

Since  $q'_{\text{conv}} \ll q'_{\text{rad}}$ , the assumption of negligible convection heat transfer is reasonable.

### PROBLEM 13.138

**KNOWN:** Diameters of coaxial cylindrical drum and heater. Heater emissivity. Temperature and emissivity of pellets covering bottom half of drum. Convection mass transfer coefficient associated with flow of dry air over the pellets.

**FIND:** (a) Evaporation rate per unit length of drum, (b) Surface temperatures of heater and top half of drum.

**SCHEMATIC:**

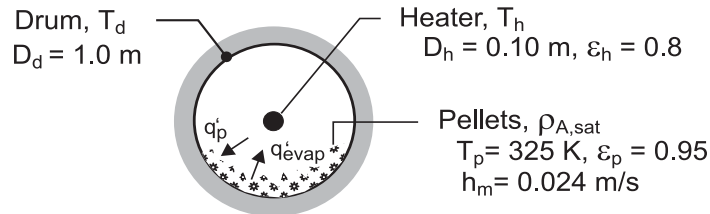

**ASSUMPTIONS:** (1) Steady-state, (2) Negligible heat transfer from ends of drum, (3) Diffuse-gray surface behavior, (4) Negligible heat loss from the drum to the surroundings, (5) Negligible convection heat transfer from interior surfaces of the drum, (6) Pellet surface area corresponds to that of bottom half of drum.

**PROPERTIES** Table A-6, sat. water ( $T = 325 \text{ K}$ ):  $\rho_{A,\text{sat}} = v_g^{-1} = 0.0904 \text{ kg/m}^3$ ,  $h_{fg} = 2378 \text{ kJ/kg}$ .

**ANALYSIS:** (a) The evaporation rate is

$$n'_A = h_m (\pi D_d / 2) [\rho_{A,\text{sat}} (T_p) - \rho_{A,\infty}]$$

$$n'_A = 0.024 \text{ m/s} (\pi \times 1 \text{ m} / 2) \times 0.0904 \text{ kg/m}^3 = 0.00341 \text{ kg/s} \cdot \text{m} \quad <$$

(b) From an energy balance on the surface of the pellets,

$$q'_p = q'_{\text{evap}} = n'_A h_{fg} = 0.00341 \text{ kg/s} \cdot \text{m} \times 2.378 \times 10^6 \text{ J/kg} = 8109 \text{ W/m} \quad <$$

where  $q'_p$  may be determined from analysis of radiation transfer in a three surface enclosure. Since the top half of the enclosure may be treated as reradiating, net radiation transfer to the pellets may be obtained from Eq. 13.30, which takes the form

$$q'_p = \frac{E_{bh} - E_{bp}}{\frac{1 - \varepsilon_h}{\varepsilon_h A'_h} + \frac{1}{A'_h F_{hp} + \left[ (1/A'_h F_{hd}) + (1/A'_p F_{pd}) \right]^{-1}} + \frac{1 - \varepsilon_p}{\varepsilon_p A'_p}}$$

where  $F_{hp} = F_{hd} = 0.5$ ,  $A'_h = \pi D_h$  and  $A'_p = \pi D_d / 2$ .

The view factor  $F_{pd}$  may be obtained from the summation rule,

$$F_{pd} = 1 - F_{ph} - F_{pp}$$

Continued ...

**PROBLEM 13.138 (Cont.)**

where  $F_{ph} = A'_h F_{hp} / A'_p = (\pi D_h \times 0.5) / (\pi D_d / 2) = 0.10$  and

$$F_{pp} = 1 - (2/\pi) \left\{ \left[ 1 - (0.1)^2 \right]^{1/2} + 0.1 \sin^{-1}(0.1) \right\} = 0.360$$

Hence,  $F_{pd} = 1 - 0.10 - 0.360 = 0.540$ , and the expression for the heat rate yields

$$8109 \text{ W/m} = \frac{E_{bh} - \sigma(325 \text{ K})^4}{\frac{0.25}{\pi \times 0.1\text{m}} + \frac{1}{\pi \left\{ 0.1\text{m} \times 0.5 + \left[ (0.1\text{m} \times 0.5)^{-1} + (0.5\text{m} \times 0.54)^{-1} \right]^{-1} \right\}} + \frac{0.053}{\pi \times 0.5\text{m}}}$$

$$E_{bh} = \sigma T_h^4 = 35,359 \text{ W/m}^2$$

$$T_h = 889 \text{ K} \quad <$$

Applying Eq. 13.19 to surfaces h and p,

$$J_h = E_{bh} - q'_h (1 - \varepsilon_h) / \varepsilon_h A'_h = 35,359 \text{ W/m}^2 - 6,453 \text{ W/m}^2 = 28,906 \text{ W/m}^2$$

$$J_p = E_{bp} + q'_p (1 - \varepsilon_p) / \varepsilon_p A'_p = 633 \text{ W/m}^2 + 272 \text{ W/m}^2 = 905 \text{ W/m}^2$$

Hence, from

$$\frac{J_h - J_d}{(A'_h F_{hd})^{-1}} - \frac{J_d - J_p}{(A'_p F_{pd})^{-1}} = 0$$

$$\frac{28,906 \text{ W/m}^2 - J_d}{(\pi \times 0.1\text{m} \times 0.5)^{-1}} - \frac{J_d - 905 \text{ W/m}^2}{(\pi \times 0.5\text{m} \times 0.54)^{-1}} = 0$$

$$J_d = \sigma T_d^4 = 24,530 \text{ W/m}^2$$

$$T_d = 811 \text{ K} \quad <$$

**COMMENTS:** The required value of  $T_h$  could be reduced by increasing  $D_h$ , although care must be taken to prevent contact of the plastic with the heater.

### PROBLEM 14.1

**KNOWN:** Mixture of O<sub>2</sub> and N<sub>2</sub> with partial pressures in the ratio 0.21 to 0.79.

**FIND:** Mass fraction of each species in the mixture.

**SCHEMATIC:**

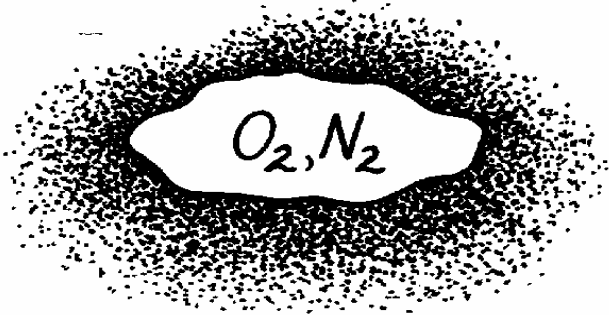

$$\frac{p_{O_2}}{p_{N_2}} = \frac{0.21}{0.79}$$

$$\mathcal{M}_{O_2} = 32 \text{ kg/kmol}$$

$$\mathcal{M}_{N_2} = 28 \text{ kg/kmol}$$

**ASSUMPTIONS:** (1) Perfect gas behavior.

**ANALYSIS:** From the definition of the mass fraction,

$$m_i = \frac{\rho_i}{\rho} = \frac{\rho_i}{\sum \rho_i}$$

Hence, with

$$\rho_i = \frac{p_i}{R_i T} = \frac{p_i}{(\mathcal{R}/\mathcal{M}_i)T} = \frac{\mathcal{M}_i p_i}{\mathcal{R}T}$$

Hence

$$m_i = \frac{\mathcal{M}_i p_i / \mathcal{R}T}{\sum \mathcal{M}_i p_i / \mathcal{R}T}$$

or, canceling terms and dividing numerator and denominator by the total pressure  $p$ ,

$$m_i = \frac{\mathcal{M}_i x_i}{\sum \mathcal{M}_i x_i}$$

With the mole fractions as

$$x_{O_2} = p_{O_2} / p = \frac{0.21}{0.21 + 0.79} = 0.21$$

$$x_{N_2} = p_{N_2} / p = 0.79,$$

find the mass fractions as

$$m_{O_2} = \frac{32 \times 0.21}{32 \times 0.21 + 28 \times 0.79} = 0.233 \quad <$$

$$m_{N_2} = 1 - m_{O_2} = 0.767. \quad <$$

## PROBLEM 14.2

**KNOWN:** Mole fraction (or mass fraction) and molecular weight of each species in a mixture of  $n$  species. Equal mole fractions (or mass fractions) of  $O_2$ ,  $N_2$  and  $CO_2$  in a mixture.

**FIND:**

**SCHEMATIC:**



$$x_{O_2} = x_{N_2} = x_{CO_2} = 0.333$$

or

$$m_{O_2} = m_{N_2} = m_{CO_2} = 0.333$$

$$\mathcal{M}_{CO_2} = 44$$

$$\mathcal{M}_{O_2} = 32, \mathcal{M}_{N_2} = 28$$

**ASSUMPTIONS:** (1) Perfect gas behavior.

**ANALYSIS:** (a) With

$$m_i = \frac{\rho_i}{\rho} = \frac{\rho_i}{\sum_i \rho_i} = \frac{p_i / R_i T}{\sum_i p_i / R_i T} = \frac{p_i \mathcal{M}_i / \mathcal{R} T}{\sum_i p_i \mathcal{M}_i / \mathcal{R} T}$$

and dividing numerator and denominator by the total pressure  $p$ ,

$$m_i = \frac{\mathcal{M}_i x_i}{\sum_i \mathcal{M}_i x_i} \quad <$$

Similarly,

$$x_i = \frac{p_i}{\sum_i p_i} = \frac{\rho_i R_i T}{\sum_i \rho_i R_i T} = \frac{(\rho_i / \mathcal{M}_i) \mathcal{R} T}{\sum_i (\rho_i / \mathcal{M}_i) \mathcal{R} T}$$

or, dividing numerator and denominator by the total density  $\rho$

$$x_i = \frac{m_i / \mathcal{M}_i}{\sum_i m_i / \mathcal{M}_i} \quad <$$

(b) With

$$\mathcal{M}_{O_2} x_{O_2} + \mathcal{M}_{N_2} x_{N_2} + \mathcal{M}_{CO_2} x_{CO_2} = 32 \times 0.333 + 28 \times 0.333 + 44 \times 0.333 = 34.6$$

$$m_{O_2} = 0.31, \quad m_{N_2} = 0.27, \quad m_{CO_2} = 0.42. \quad <$$

With

$$m_{O_2} / \mathcal{M}_{O_2} + m_{N_2} / \mathcal{M}_{N_2} + m_{CO_2} / \mathcal{M}_{CO_2} = 0.333 / 32 + 0.333 / 28 + 0.333 / 44$$

$$m_{O_2} = 2.987 \times 10^{-2}.$$

find

$$x_{O_2} = 0.35, \quad x_{N_2} = 0.40, \quad x_{CO_2} = 0.25. \quad <$$

### PROBLEM 14.3

**KNOWN:** Partial pressures and temperature for a mixture of CO<sub>2</sub> and N<sub>2</sub>.

**FIND:** Molar concentration, mass density, mole fraction and mass fraction of each species.

**SCHEMATIC:**

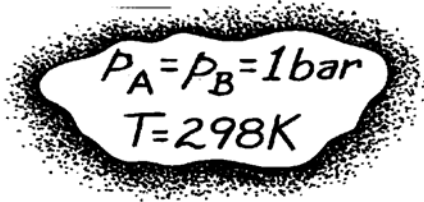

A hand-drawn schematic consisting of a cloud-like shape with a stippled border. Inside the cloud, the text reads:  $p_A = p_B = 1 \text{ bar}$  and  $T = 298 \text{ K}$ .

$$A \rightarrow \text{CO}_2, \mathcal{M}_A = 44 \text{ kg/kmol}$$

$$B \rightarrow \text{N}_2, \mathcal{M}_B = 28 \text{ kg/kmol}$$

**ASSUMPTIONS:** (1) Perfect gas behavior.

**ANALYSIS:** From the equation of state for an ideal gas,

$$C_i = \frac{p_i}{\mathcal{R}T}$$

Hence, with  $p_A = p_B$ ,

$$C_A = C_B = \frac{1 \text{ bar}}{8.314 \times 10^{-2} \text{ m}^3 \cdot \text{bar/kmol} \cdot \text{K} \times 298 \text{ K}}$$

$$C_A = C_B = 0.040 \text{ kmol/m}^3. \quad <$$

With  $\rho_i = \mathcal{M}_i C_i$ , it follows that

$$\rho_A = 44 \text{ kg/kmol} \times 0.04 \text{ kmol/m}^3 = 1.78 \text{ kg/m}^3 \quad <$$

$$\rho_B = 28 \text{ kg/kmol} \times 0.04 \text{ kmol/m}^3 = 1.13 \text{ kg/m}^3. \quad <$$

Also, with

$$x_i = C_i / \sum_i C_i$$

find

$$x_A = x_B = 0.04 / 0.08 = 0.5 \quad <$$

and with

$$m_i = \rho_i / \sum \rho_i$$

find

$$m_A = 1.78 / (1.78 + 1.13) = 0.61 \quad <$$

$$m_B = 1.13 / (1.78 + 1.13) = 0.39. \quad <$$

### PROBLEM 14.4

**KNOWN:** He-Xe mixture containing 0.75 mole fraction of He at 300 K and 1 atm.

**FIND:** Mass fraction of He and mixture mass density, molar concentration, and molecular weight. Mass of coolant in 10 liters.

**SCHEMATIC:**

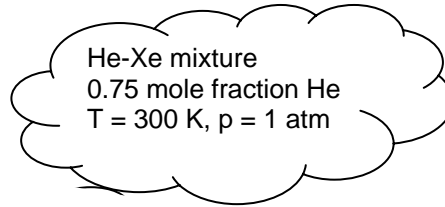

**ASSUMPTIONS:** Ideal gas mixture.

**PROPERTIES:**  $\mathcal{M}_{\text{He}} = 4 \text{ kg/kmol}$ ,  $\mathcal{M}_{\text{Xe}} = 131.3 \text{ kg/kmol}$

**ANALYSIS:** The molar concentration of the mixture can be found directly from the ideal gas law, in the form

$$C = \frac{p}{\mathcal{R}T} = \frac{1 \text{ atm}}{8.205 \times 10^{-2} \text{ m}^3 \cdot \text{atm/kmol} \cdot \text{K} \times 300 \text{ K}} = 0.0406 \text{ kmol/m}^3 \quad <$$

The mass density of one component in a mixture can be related to the mole fraction by combining Eqs. 14.11 and 14.1 to yield

$$\rho_i = \mathcal{M}_i x_i C$$

For He this results in

$$\rho_{\text{He}} = 4 \text{ kg/kmol} \times 0.75 \times 0.0406 \text{ kmol/m}^3 = 0.1219 \text{ kg/m}^3$$

Then the total mass density can be found by summing the species mass densities,

$$\rho = \sum_i \rho_i = C \sum_i \mathcal{M}_i x_i = 0.0406 [4 \text{ kg/kmol} \times 0.75 + 131.3 \text{ kg/kmol} \times 0.25]$$
$$\rho = 1.455 \text{ kg/m}^3 \quad <$$

Thus the helium mass fraction is

$$m_{\text{He}} = \frac{\rho_{\text{He}}}{\rho} = \frac{0.1219 \text{ kg/m}^3}{1.455 \text{ kg/m}^3} = 0.0837 \quad <$$

Finally, the molecular weight of the mixture can be found from

Continued...

**PROBLEM 14.4 (Cont.)**

$$\mathcal{M} = \frac{\rho}{C} = \frac{1.455 \text{ kg/m}^3}{0.0406 \text{ kmol/m}^3} = 35.8 \text{ kg/kmol} \quad <$$

Finally, the mass corresponding to a 10 liter cooling system capacity would be

$$M = \rho V = 1.455 \text{ kg/m}^3 \times 10 \text{ liters} \times 10^{-3} \text{ m}^3/\text{liter} = 0.0146 \text{ kg} \quad <$$

**COMMENTS:** (1) As you may recall from thermodynamics, the molar concentration of an ideal gas is a function only of pressure and temperature, independent of the species. (2) The mass fraction of helium is much less than its mole fraction because its molecular weight is so much less than that of xenon.



### PROBLEM 14.5

**KNOWN:** Mass diffusion coefficients of two binary mixtures at a given temperature, 298 K.

**FIND:** Mass diffusion coefficients at a different temperature,  $T = 350$  K.

**ASSUMPTIONS:** (a) Ideal gas behavior, (b) Mixtures at 1 atm total pressure.

**PROPERTIES:** Table A-8, Ammonia-air binary mixture (298 K),  $D_{AB} = 0.28 \times 10^{-4} \text{ m}^2/\text{s}$ ;  
Hydrogen-air binary mixture (298 K),  $D_{AB} = 0.41 \times 10^{-4} \text{ m}^2/\text{s}$ .

**ANALYSIS:** According to treatment of Section 14.1.4, assuming ideal gas behavior,

$$D_{AB} \sim T^{3/2}$$

where  $T$  is in kelvin units. It follows then, that for

$$\text{NH}_3 - \text{Air}: \quad D_{AB}(350 \text{ K}) = 0.28 \times 10^{-4} \text{ m}^2/\text{s} (350 \text{ K}/298 \text{ K})^{3/2}$$

$$D_{AB}(350 \text{ K}) = 0.36 \times 10^{-4} \text{ m}^2/\text{s} \quad <$$

$$\text{H}_2 - \text{Air}: \quad D_{AB}(350 \text{ K}) = 0.41 \times 10^{-4} \text{ m}^2/\text{s} (350/298)^{3/2}$$

$$D_{AB}(350 \text{ K}) = 0.52 \times 10^{-4} \text{ m}^2/\text{s} \quad <$$

**COMMENTS:** Since the  $\text{H}_2$  molecule is smaller than the  $\text{NH}_3$  molecule, it follows that

$$D_{\text{H}_2-\text{Air}} > D_{\text{NH}_3-\text{Air}}$$

as indeed the numerical data indicate.

## PROBLEM 14.6

**KNOWN:** Pressure and temperature. Substance A and Substance B.

**FIND:** Plot of  $D_{AB}$  versus  $\mathcal{M}_A$  for  $\text{NH}_3$ ,  $\text{H}_2\text{O}$ ,  $\text{CO}_2$ ,  $\text{H}_2$ ,  $\text{O}_2$ , acetone, benzene and naphthalene in air.

**ASSUMPTIONS:** Ideal gas behavior.

<b>PROPERTIES:</b>	<u>Substance A (<math>T, p</math>)</u>	<u><math>D_{AB}^*</math> (<math>\text{m}^2/\text{s}</math>)</u>	<u><math>\mathcal{M}_A</math> (kg/kmol)</u>
	$\text{NH}_3$ (298 K, 1 atm)	$0.28 \times 10^{-4}$	17.03 **
	$\text{H}_2\text{O}$ (298 K, 1 atm)	$0.26 \times 10^{-4}$	18.02 **
	$\text{CO}_2$ (298 K, 1 atm)	$0.16 \times 10^{-4}$	44.01 **
	$\text{H}_2$ (298 K, 1 atm)	$0.41 \times 10^{-4}$	2.016 **
	$\text{O}_2$ (298 K, 1 atm)	$0.21 \times 10^{-4}$	32.00 **
	Acetone (273 K, 1 atm)	$0.11 \times 10^{-4}$	58.08 ***
	Benzene (298 K, 1 atm)	$0.88 \times 10^{-5}$	78.11 *****
	Naphthalene (300 K, 1 atm)	$0.62 \times 10^{-5}$	128.16 *****

\* Table A.8

\*\* Table A.4

\*\*\* J.R. Howell and R.O. Buckius, *Fundamentals of Engineering Thermodynamics*, 2<sup>nd</sup> ed., McGraw-Hill, 1992.

\*\*\*\* M.J. Moran and H.N. Shapiro, *Fundamentals of Engineering Thermodynamics*, 6<sup>th</sup> ed., John Wiley and Sons, Hoboken, 2008.

\*\*\*\*\* Problem 6.63

**ANALYSIS:** The mass diffusivity values must be corrected to account for the temperature and pressure dependence. From Table A.8,  $D_{AB} \propto p^{-1}T^{3/2}$  and the corrected mass diffusivity for  $\text{NH}_3$  is

$$D_{ABc} = 0.28 \times 10^{-4} \text{ m}^2/\text{s} \times (1 \text{ atm} / 1.5 \text{ atm}) \times (320 \text{ K} / 298 \text{ K})^{3/2} = 0.21 \times 10^{-4} \text{ m}^2/\text{s}$$

Repeating the calculation for the other substances yields the following.

<u>Substance A</u>	<u><math>D_{ABc}</math> (<math>\text{m}^2/\text{s}</math>)</u>
$\text{NH}_3$	$0.21 \times 10^{-4}$
$\text{H}_2\text{O}$	$0.19 \times 10^{-4}$
$\text{CO}_2$	$0.12 \times 10^{-4}$
$\text{H}_2$	$0.30 \times 10^{-4}$
$\text{O}_2$	$0.16 \times 10^{-4}$
Acetone	$0.93 \times 10^{-5}$
Benzene	$0.65 \times 10^{-5}$
Naphthalene	$0.46 \times 10^{-5}$

A plot of the corrected mass diffusivities versus molecular weight of Substance A follows.

Continued...

### PROBLEM 14.6 (Cont.)

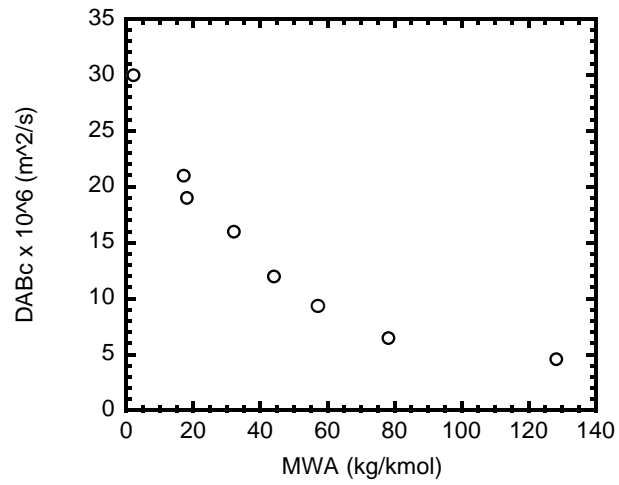

According to kinetic theory, the mass diffusivity decreases with increasing molecular weight. This behavior is readily evident in the plot, and therefore the kinetic theory is consistent with measured values. <

**COMMENTS:** Small molecules can diffuse through the host medium more readily than large molecules.

## PROBLEM 14.7

**KNOWN:** The inner and outer surfaces of an iron cylinder of 100-mm length are exposed to a carburizing gas (mixtures of CO and CO<sub>2</sub>). Observed experimental data on the variation of the carbon composition (weight carbon, %) in the iron at 1000°C as a function of radius. Carbon flow rate under steady-state conditions.

**FIND:** (a) Beginning with Fick's law, show that  $d\rho_c / d(\ln(r))$  is a constant if the diffusion coefficient,  $D_{C-Fe}$ , is a constant; sketch of the carbon mass density,  $\rho_c(r)$ , as function of  $\ln(r)$  for such a diffusion process; (b) Create a graph for the experimental data and determine whether  $D_{C-Fe}$  for this diffusion process is constant, increases or decreases with increasing mass density; and (c) Using the experimental data, calculate and tabulate  $D_{C-Fe}$  for selected carbon compositions over the range of the experiment.

**SCHEMATIC:**

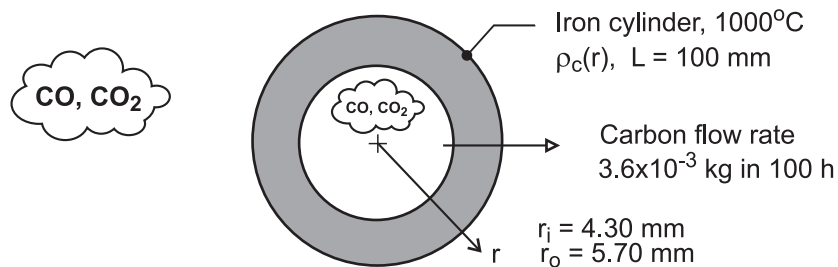

**PROPERTIES:** Iron (1000°C).  $\rho = 7730 \text{ kg/m}^3$ . Experimental observations of carbon composition

r (mm)	4.49	4.66	4.79	4.91	5.16	5.27	5.40	5.53
Wt. C (%)	1.42	1.32	1.20	1.09	0.82	0.65	0.46	0.28

**ASSUMPTIONS:** (1) Steady-state conditions, (2) One-dimensional, radial diffusion in a stationary medium, and (3) Uniform total concentration.

**ANALYSIS:** (a) For the one-dimensional, radial (cylindrical) coordinate system, Fick's law is

$$j_A = -D_{AB} A_r \frac{d\rho_A}{dr} \quad (1)$$

where  $A_r = 2\pi rL$ . For steady-state conditions,  $j_A$  is constant, and if  $D_{AB}$  is constant, the product

$$r \frac{d\rho_A}{dr} = C_1 \quad (2)$$

must be a constant. Using the differential relation  $dr/r = d(\ln r)$ , it follows that

$$\frac{d\rho_A}{d(\ln r)} = C_1 \quad (3)$$

so that on a  $\ln(r)$  plot,  $\rho_A$  is a straight line. See the graph below for this behavior.

Continued ...

### PROBLEM 14.7 (Cont.)

(b) To determine whether  $D_{C-Fe}$  is a constant for the experimental diffusion process, the data are represented on a  $\ln(r)$  coordinate.

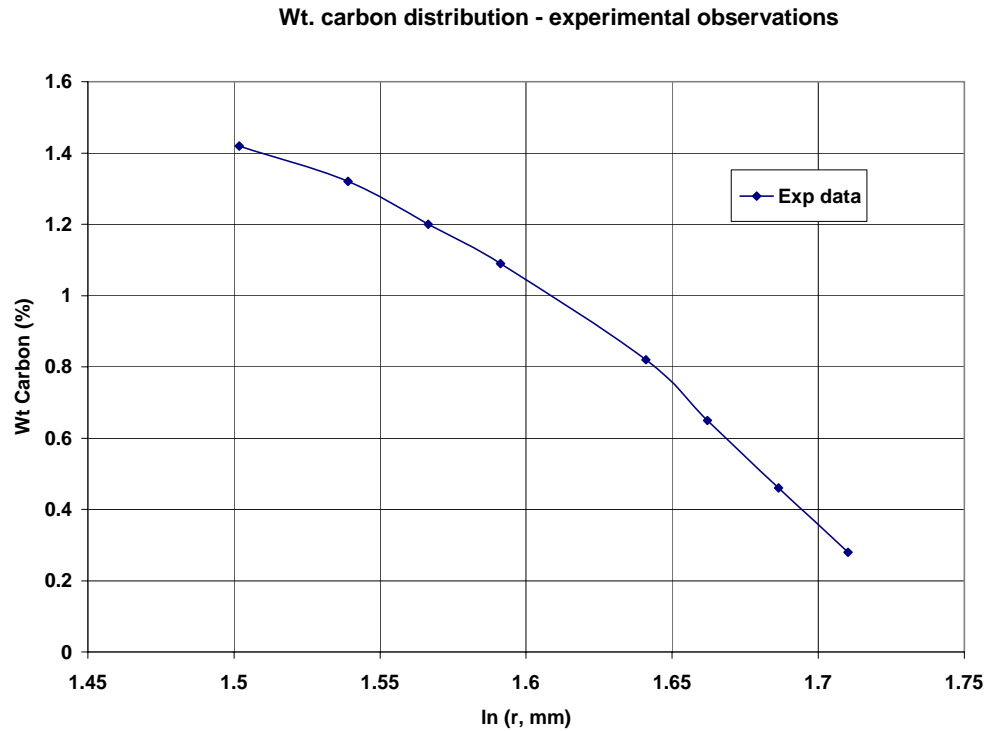

Since the plot is not linear,  $D_{C-Fe}$  is not a constant. From the treatment of part (a), if  $D_{AB}$  is not a constant, then

$$D_{AB} \frac{d\rho_A}{d(\ln r)} = C_2$$

must be constant. We conclude that  $D_{C-Fe}$  will be lower at the radial position where the gradient is higher. Hence, we expect  $D_{C-Fe}$  to increase with increasing carbon content.

(c) From a plot of Wt - %C vs.  $r$  (not shown), the mass fraction gradient is determined at three locations and Fick's law is used to calculate the diffusion coefficient,

$$j_c = -\rho \cdot A_r \cdot D_{C-Fe} \frac{\Delta (\text{Wt} - \% \text{ C})}{\Delta r}$$

where the mass flow rate is

$$j_c = 3.6 \times 10^{-3} \text{ kg} / 100 \text{ h} (3600 \text{ s} / \text{h}) = 1 \times 10^{-8} \text{ kg} / \text{s}$$

and  $\rho = 7730 \text{ kg} / \text{m}^3$ , density of iron. The results of this analysis yield,

Wt - C (%)	$r$ (mm)	$\Delta \text{Wt-C} / \Delta r$ (%/mm)	$D_{C-Fe} \times 10^{11}$ ( $\text{m}^2 / \text{s}$ )
1.32	4.66	-0.679	6.51
0.955	5.04	-1.08	3.79
0.37	5.47	-1.385	2.72

### PROBLEM 14.8

**KNOWN:** Air is enclosed at uniform pressure in a vertical, cylindrical container whose top and bottom surfaces are maintained at different temperatures.

**FIND:** (a) Conditions in air when bottom surface is colder than top surface, (b) Conditions when bottom surface is hotter than top surface.

**SCHEMATIC:**

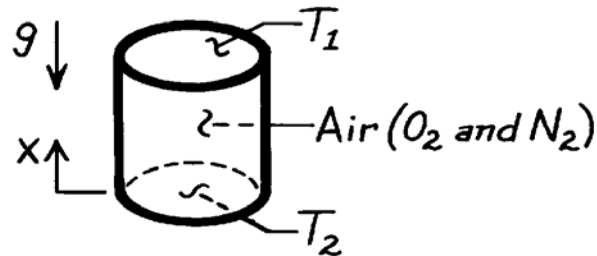

**ASSUMPTIONS:** (1) Uniform pressure, (2) Perfect gas behavior.

**ANALYSIS:** (a) If  $T_1 > T_2$ , the axial temperature gradient ( $dT/dx$ ) will result in an axial density gradient. However, since  $d\rho/dx < 0$  there will be no buoyancy driven, convective motion of the mixture.

There will also be axial species density gradients,  $d\rho_{O_2}/dx$  and  $d\rho_{N_2}/dx$ . However, there is no gradient associated with the mass fractions ( $dm_{O_2}/dx = 0$ ,  $dm_{N_2}/dx = 0$ ). Hence, from Fick's law, Eq. 14.12, there is *no* mass transfer by diffusion.

(b) If  $T_1 < T_2$ ,  $d\rho/dx > 0$  and there may be a buoyancy driven, convective motion of the mixture. However,  $dm_{O_2}/dx = 0$  and  $dm_{N_2}/dx = 0$ , and there is still *no* mass transfer. Hence, although there is motion of each species with the convective motion of the mixture, there is *no relative motion* between species.

**COMMENTS:** The commonly used special case of Fick's law,

$$j_A = -D_{AB} \frac{d\rho_A}{dx}$$

would be inappropriate for this problem since  $\rho$  is not uniform. If applied, this special case indicates that mass transfer would occur, thereby providing an incorrect result.

### PROBLEM 14.9

**KNOWN:** Dimensions of rubber stopper in medicine jar. Molar concentration of medicine vapor at top and bottom surfaces. Mass diffusivity of medicine vapor in rubber.

**FIND:** Rate at which medicine vapor exits through the stopper.

**SCHEMATIC:**

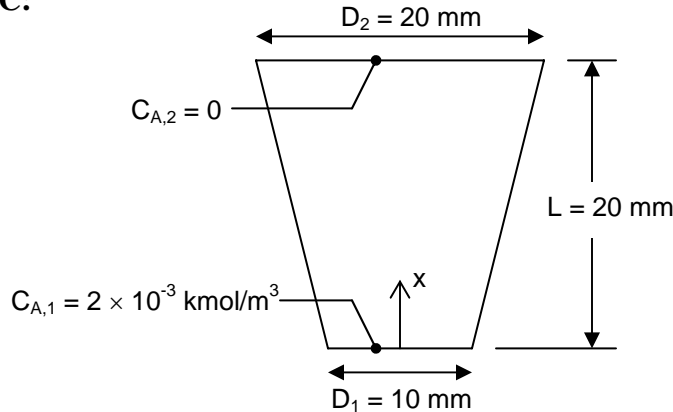

**ASSUMPTIONS:** (1) Glass neck is impermeable to medicine vapor, thus there is negligible mass loss out of slanted surface, (2) One-dimensional mass diffusion, (3) Steady state, (4) Constant properties, (5) No chemical reaction.

**PROPERTIES:** Medicine vapor-rubber (given):  $D_{AB} = 0.2 \times 10^{-9} \text{ m}^2/\text{s}$ .

**ANALYSIS:** The analysis follows the “alternative conduction analysis” approach. For one-dimensional diffusion in the  $x$ -direction, Fick’s Law in molar form, Eq. 14.13, reduces to

$$J_A^* = -CD_{AB} \frac{dx_A}{dx} = -D_{AB} \frac{dC_A}{dx} \quad (1)$$

where the total concentration,  $C$ , has been assumed constant. The transfer rate of species A through the entire stopper cross-section,  $N_A$ , can be expressed as  $N_A = J_A^* A_c$ , where  $A_c$  is the cross-sectional area. For steady-state, one-dimensional diffusion with no chemical reaction, the species transfer rate must be constant. We multiply Eq. (1) by  $A_c$ , separate variables, and integrate between the top and bottom of the stopper, as follows

$$N_A = J_A^* A_c = -D_{AB} A_c \frac{dC_A}{dx}$$

$$N_A \int_0^L \frac{dx}{A_c} = -D_{AB} \int_{x_{A1}}^{x_{A2}} dC_A = D_{AB} (C_{A1} - C_{A2}) = D_{AB} C_{A1} \quad (2)$$

The cross-sectional area is given by

$$A_c = \pi R^2, \text{ where } R = R_1 + (R_2 - R_1)x/L$$

Continued...

### PROBLEM 14.9 (Cont.)

Thus  $dx = LdR/(R_2 - R_1)$ , and Eq. (2) becomes

$$N_A \int_{R_1}^{R_2} \frac{dR}{\pi R^2} \frac{L}{R_2 - R_1} = D_{AB} C_{A1}$$
$$\frac{N_A}{\pi} \left( \frac{1}{R_1} - \frac{1}{R_2} \right) \frac{L}{R_2 - R_1} = D_{AB} C_{A1}$$

Thus

$$N_A = \frac{\pi D_{AB} C_{A1} R_1 R_2}{L}$$
$$= \frac{\pi \times 0.2 \times 10^{-9} \text{ m}^2 / \text{s} \times 2 \times 10^{-3} \text{ kmol} / \text{m}^3 \times 0.005 \text{ m} \times 0.01 \text{ m}}{0.02 \text{ m}}$$

$$N_A = 3.14 \times 10^{-15} \text{ kmol} / \text{s}$$

<

**COMMENTS:** (1) The assumption of constant concentration,  $C$ , is excellent because the “mixture” of rubber and medicine vapor would be dominated by the rubber. (2) Using the properties of water for the medicine, we can estimate how much the liquid would be depleted per year. The molar loss in one year is  $3.14 \times 10^{-15} \text{ kmol} / \text{s} \times 3.15 \times 10^7 \text{ s} / \text{yr} = 9.9 \times 10^{-8} \text{ kmol} / \text{yr}$ . If the molecular weight is  $18 \text{ kg} / \text{kmol}$ , the loss would be  $1.8 \times 10^{-6} \text{ kg} / \text{yr}$ . If the liquid density is  $1000 \text{ kg} / \text{m}^3$ , the volume loss would be  $1.8 \times 10^{-9} \text{ m}^3 / \text{yr}$ . For a bottle cross-sectional area of  $2 \times 10^{-3} \text{ m}^2$ , the liquid level would drop by less than  $1 \text{ } \mu\text{m}$  per year.



## PROBLEM 14.10

**KNOWN:** Evaporation of liquid A into a column containing vapor A and B. Species B cannot be absorbed in liquid A.

**FIND:** The relationship between the ratio of the molar-average velocity to the species velocity of species A to the mole fraction of species A.

**SCHEMATIC:**

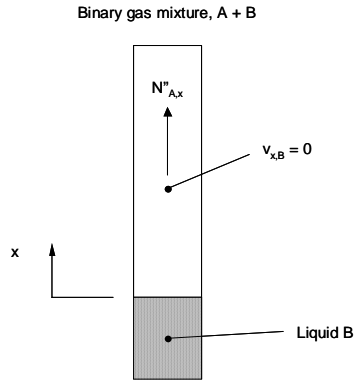

**ASSUMPTIONS:** (1) Steady, one-dimensional diffusion, (2) No chemical reactions.

**ANALYSIS:** From Section 14.2.2, we know that  $N''_{B,x} = 0$ . From Eq. 14.27,

$$N''_{A,x} = C_A v_{A,x} \quad \text{and} \quad N''_{B,x} = C_B v_{B,x} = 0 \quad \text{or} \quad v_{B,x} = 0 \quad (1)$$

From Eq. 14.29,

$$v_x^* = X_A v_{A,x} \quad (2)$$

Therefore

$$\frac{v_x^*}{v_{A,x}} = X_A \quad <$$

The relationship is shown in the graph below.

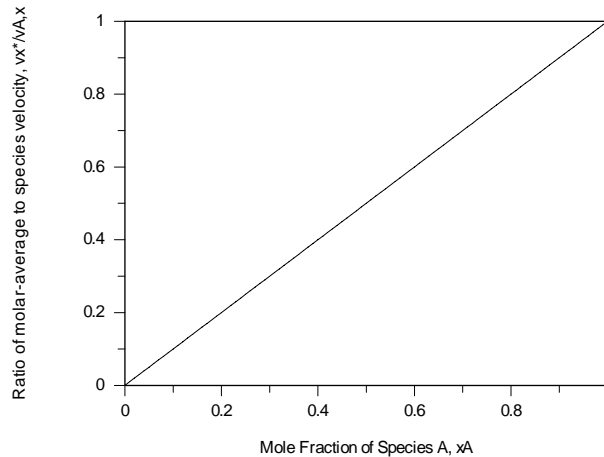

Continued...

### PROBLEM 14.10 (Cont.)

**COMMENTS:** (1) When the mole fraction of Species A is small and Species B is not in motion, the molar-average velocity is dominated by Species B and is negligible compared to the non-zero species velocity of A. In other words, the vapor in the column can be treated as a stationary medium since, although Species A is in motion, there is very little species A present. (2) When the mole fraction of Species A is large, there is very little Species B present, and the velocity of the mixture is dominated by the velocity of Species A. Hence, the velocity ratio approaches unity as mixture becomes dominated by Species A.

### PROBLEM 14.11

**KNOWN:** Water in an open pan exposed to prescribed ambient conditions.

**FIND:** Evaporation rate considering (a) diffusion only and (b) convective effects.

**SCHEMATIC:**

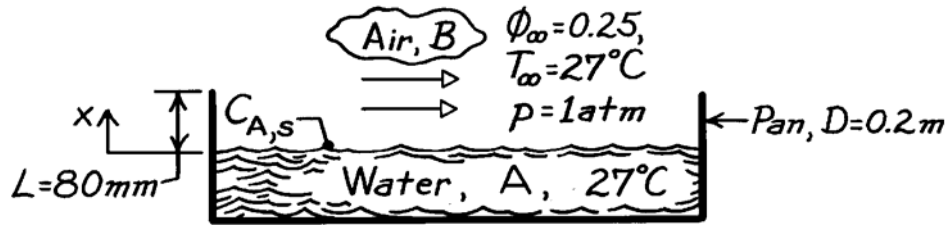

**ASSUMPTIONS:** (1) Steady-state conditions, (2) One-dimensional diffusion, (3) Constant properties, (4) Uniform T and p, (5) Perfect gas behavior.

**PROPERTIES:** Table A-8, Water vapor-air ( $T = 300 \text{ K}$ , 1 atm),  $D_{AB} = 0.26 \times 10^{-4} \text{ m}^2/\text{s}$ ; Table A-6, Water vapor ( $T = 300 \text{ K}$ , 1 atm),  $p_{\text{sat}} = 0.03531 \text{ bar}$ ,  $v_g = 39.13 \text{ m}^3/\text{kg}$ .

**ANALYSIS:** (a) The evaporation rate considering only diffusion follows from Eq. 14.32 simplified for a stationary medium. That is,

$$N_{A,x} = N''_{A,x} \cdot A = -D_{AB} A \frac{dC_A}{dx}.$$

Recognizing that  $\phi \equiv p_A/p_{A,\text{sat}} = C_A/C_{A,\text{sat}}$ , the rate is expressed as

$$N_{A,x} = -D_{AB} A \frac{C_{A,\infty} - C_{A,s}}{L} = \frac{D_{AB} A}{L} C_{A,\text{sat}} (1 - \phi_\infty)$$

$$N_{A,x} = \frac{0.26 \times 10^{-4} \text{ m}^2/\text{s} (\pi/4) (0.2 \text{ m})^2}{80 \times 10^{-3} \text{ m}} \frac{1}{39.13 \text{ m}^3/\text{kg} \times 18 \text{ kg}/\text{kmol}} (1 - 0.25) = 1.087 \times 10^{-8} \text{ kmol}/\text{s}$$

where  $C_{A,s} = 1/(v_g \mathcal{M}_A)$  with  $\mathcal{M}_A = 18 \text{ kg}/\text{kmol}$ .

(b) The evaporation rate considering convective effects using Eq. 14.40 is

$$N_{A,x} = N''_{A,x} \cdot A = \frac{CD_{AB}A}{L} \ln \frac{1 - x_{A,L}}{1 - x_{A,0}}.$$

Using the perfect gas law, the total concentration of the mixture is

$$C = p/\mathcal{R}T = 1.0133 \text{ bar} / (8.314 \times 10^{-2} \text{ m}^3 \cdot \text{bar}/\text{kmol} \cdot \text{K} \times 300 \text{ K}) = 0.04063 \text{ kmol}/\text{m}^3$$

where  $p = 1 \text{ atm} = 1.0133 \text{ bar}$ . The mole fractions at  $x = 0$  and  $x = L$  are

$$x_{A,0} = \frac{p_{A,s}}{p} = \frac{0.03531 \text{ bar}}{1.0133 \text{ bar}} = 0.0348 \quad x_{A,L} = \phi_\infty x_{A,0} = 0.0087.$$

Hence

$$N_{A,x} = \frac{0.04063 \text{ kmol}/\text{m}^3 \times 0.26 \times 10^{-4} \text{ m}^2/\text{s} (\pi/4) (0.2 \text{ m})^2}{80 \times 10^{-3} \text{ m}} \ln \frac{1 - 0.0087}{1 - 0.0348} = 1.107 \times 10^{-8} \text{ kmol}/\text{s} \quad <$$

**COMMENTS:** For this situation, the advective effect is very small but does tend to increase (by 1.5%) the evaporation rate as expected.

## PROBLEM 14.12

**KNOWN:** Spherical droplet of liquid A and radius  $r_o$  evaporating into stagnant gas B.

**FIND:** Evaporation rate of species A in terms of  $p_{A,sat}$ , partial pressure  $p_A(r)$ , the total pressure  $p$  and other pertinent parameters.

**SCHEMATIC:**

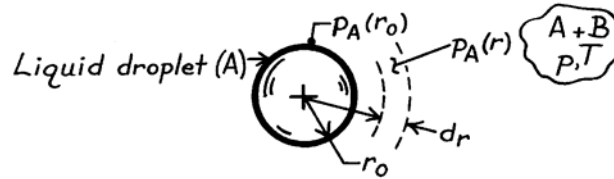

**ASSUMPTIONS:** (1) Steady-state conditions, (2) One-dimensional, radial, species diffusion, (3) Constant properties, including total concentration, (4) Droplet and mixer air at uniform pressure and temperature, (5) Perfect gas behavior.

**ANALYSIS:** From Eq. 14.32 for a radial spherical coordinate system, the evaporation rate of liquid A into a binary gas mixture A + B is

$$N_{A,r} = -D_{AB}A_r \frac{dC_A}{dr} + \frac{C_A}{C} N_{A,r}$$

where  $A_r = 4\pi r^2$  and  $N_{A,r} = N_A$ , a constant,

$$N_A \left( 1 - \frac{C_A}{C} \right) = -D_{AB} \cdot 4\pi r^2 \cdot \frac{dC_A}{dr}$$

From perfect gas behavior,  $C_A = p_A / \mathfrak{R}T$  and  $C = p / \mathfrak{R}T$ ,

$$N_A (p - p_A) = -D_{AB} \cdot 4\pi r^2 \cdot \frac{p}{\mathfrak{R}T} \frac{dp_A}{dr}$$

Separating variables, setting definite limits, and integrating

$$-N_A \frac{\mathfrak{R}T}{p} \frac{1}{4\pi D_{AB}} \int_{r_o}^r \frac{dr}{r^2} = \int_{p_{A,r_o}}^{p_{A,r}} \frac{dp_A}{p - p_A}$$

find that

$$N_A = 4\pi r_o D_{AB} \frac{p}{\mathfrak{R}T} \frac{1}{1 - r_o/r} \ln \frac{p - p_A(r)}{p - p_{A,o}} \quad <$$

where  $p_{A,o} = p_A(r_o) = p_{A,sat}$ , the saturation pressure of liquid A at temperature T.

**COMMENTS:** Compare the method of solution and result with the content of Section 14.2.2, Evaporation in a Column.

### PROBLEM 14.13

**KNOWN:** Clean surface with pure steam has condensate rate of  $0.020 \text{ kg/m}^2 \cdot \text{s}$  for the prescribed conditions. With the presence of stagnant air in the steam, the condensate surface drops from  $28^\circ\text{C}$  to  $24^\circ\text{C}$  and the condensate rate is halved.

**FIND:** Partial pressure of air in the air-steam mixture as a function of distance from the condensate film.

**SCHEMATIC:**

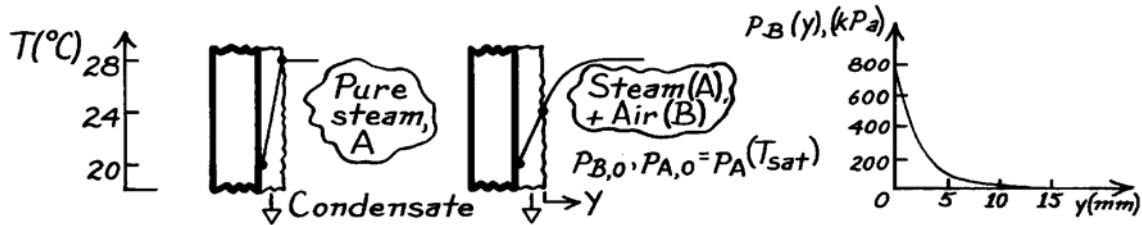

**ASSUMPTIONS:** (1) Steady-state conditions, (2) Constant properties including pressure in air-steam mixture, (3) Perfect gas behavior.

**PROPERTIES:** Table A-6, Water vapor:  $p_{\text{sat}}(28^\circ\text{C} = 301 \text{ K}) = 0.03767 \text{ bar}$ ;  $p_{\text{sat}}(24^\circ\text{C} = 297 \text{ K}) = 0.02983 \text{ bar}$ ; Table A-8, Water-air (298 K, 1 bar):  $D_{\text{AB}} = 0.26 \times 10^{-4} \text{ m}^2/\text{s}$ .

**ANALYSIS:** The partial pressure distribution of the air as a function of distance  $y$  can be found from the species (A) rate expression, Eq. 14.40,

$$N''_{\text{A},y} = (CD_{\text{AB}}/y) \ln\left(\frac{1-x_{\text{A},y}}{1-x_{\text{A},0}}\right).$$

With  $C = p/\mathcal{R}T$ ,  $x_{\text{B},y} = 1 - x_{\text{A},y}$  and  $x_{\text{B},0} = 1 - x_{\text{A},0}$ , recognizing that  $x_{\text{B}} = p_{\text{B}}/p$ , find

$$p_{\text{B}}(y) = p_{\text{B},0} \cdot \exp\left(N''_{\text{A},y} \frac{\mathcal{R}T}{pD_{\text{AB}}} y\right)$$

$$p_{\text{B},0} = p - p_{\text{A},0} = p_{\text{sat}}(28^\circ\text{C}) - p_{\text{sat}}(24^\circ\text{C}) = (0.03767 - 0.02983) \text{ bar} = 0.00784 \text{ bar}.$$

With  $N''_{\text{A},y} = -(0.020/2) \text{ kg/m}^2 \cdot \text{s} / 29 \text{ kg/kmol} = 3.45 \times 10^{-4} \text{ kmol/m}^2 \cdot \text{s}$ ,

$$p_{\text{B}}(y) = 0.0784 \text{ bar} \times \exp\left(3.45 \times 10^{-4} \text{ kmol/m}^2 \cdot \text{s} \frac{8.314 \times 10^{-2} \text{ m}^3 \cdot \text{bar/kmol} \cdot \text{K} \times 299 \text{ K}}{0.03767 \text{ bar} \times 6.902 \times 10^{-4} \text{ m}^2/\text{s}} y\right)$$

$$p_{\text{B}}(y) = 784 \text{ kPa} \times \exp(-0.330y)$$

with  $p_{\text{B}}$  in [kPa] and  $y$  in [mm], where  $T = 26^\circ\text{C} = 299 \text{ K}$ , the average temperature of the air-steam mixture, and  $D_{\text{AB}} \approx p^{-1} T^{3/2} = 0.26 \times 10^{-4} \text{ m}^2/\text{s} (1/0.03767) (299/298)^{3/2} = 6.902 \times 10^{-4} \text{ m}^2/\text{s}$ .

Selected values for the pressure are shown below and the distribution is shown above:

$y$ (mm)	0	5	10	15
$p_{\text{B}}(y)$ (kPa)	784	151	29.0	5.6

**COMMENTS:** To minimize inert gas effects, the usual practice is to pass vapor over the surfaces so that the inerts are eventually collected near the outlet region of the condenser. Our estimate shows that the effective region to be swept is approximately 10 mm thick.

## PROBLEM 14.14

**KNOWN:** Column containing liquid phase of water (A) evaporates into the air (B) flowing over the mouth of the column.

**FIND:** Evaporation rate of water ( $\text{kg}/\text{h}\cdot\text{m}^2$ ) using the known value of the binary diffusion coefficient for the water vapor - air mixture.

**SCHEMATIC:**

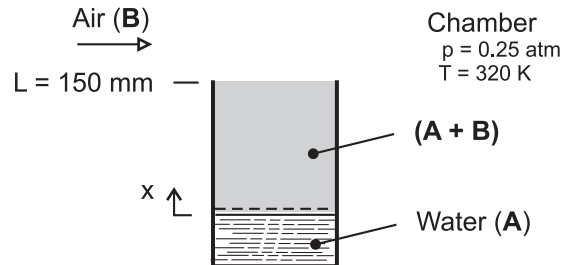

**ASSUMPTIONS:** (1) Steady-state, one-dimensional diffusion in the column, (2) Constant properties, (3) Uniform temperature and pressure throughout the column, (4) Water vapor exhibits ideal gas behavior, and (5) Negligible water vapor in the chamber air.

**PROPERTIES:** Table A-6, water ( $T = 320 \text{ K}$ ):  $p_{\text{sat}} = 0.1053 \text{ bar}$ ; Table A-8, water vapor-air (0.25 atm, 320 K): Since  $D_{AB} \sim p^{-1} T^{3/2}$  find

$$D_{AB} = 0.26 \times 10^{-4} \text{ m}^2 / \text{s} (1.00 / 0.25) (320 / 298)^{3/2} = 1.157 \times 10^{-4} \text{ m}^2 / \text{s}$$

**ANALYSIS:** From Eq. 14.40, the molar flow rate per unit area is

$$N''_{A,x} = \frac{C D_{AB}}{L} \ln \frac{1 - x_{A,L}}{1 - x_{A,0}}$$

where  $C$  is the mixture concentration determined from the ideal gas law as

$$C = \frac{p}{\mathcal{R}T} = \frac{0.25 \text{ atm}}{8.205 \times 10^{-2} \text{ m}^3 \cdot \text{atm}/\text{kmol} \cdot \text{K} \times 320 \text{ K}} = 0.009397 \text{ kmol}/\text{m}^3$$

where  $\mathcal{R} = 8.205 \times 10^{-2} \text{ m}^3 \cdot \text{atm}/\text{kmol} \cdot \text{K}$ . The mole fractions at  $x = 0$  and  $x = L$  are

$$x_{A,L} = 0 \quad (\text{no water vapor in air above column})$$

$$x_{A,0} = p_A / p = 0.1053 / 0.25 = 0.4212$$

where  $p_A$  is the saturation pressure for water at  $T = 320 \text{ K}$ . Substituting numerical values

$$N''_{A,x} = \frac{0.009397 \text{ kmol} / \text{m}^3 \times 1.157 \times 10^{-4} \text{ m}^2 / \text{s}}{0.150 \text{ m}} \ln \frac{(1-0)}{(1-0.4212)}$$

$$N''_{A,x} = 3.964 \times 10^{-6} \text{ kmol} / \text{m}^2 \cdot \text{s}$$

or, on a mass basis,

$$m''_{A,x} = N''_{A,x} \mathcal{M}_A$$

$$m''_{A,x} = 3.964 \times 10^{-6} \text{ kmol} / \text{m}^2 \cdot \text{s} \times 3600 \text{ s} / \text{h} \times 18 \text{ kg} / \text{kmol}$$

$$m''_{A,x} = 0.257 \text{ kg} / \text{m}^2 \cdot \text{h}$$

<

### PROBLEM 14.15

**KNOWN:** Molar concentrations of helium at the inner and outer surfaces of a plastic membrane. Diffusion coefficient and membrane thickness.

**FIND:** Molar diffusion flux.

**SCHEMATIC:**

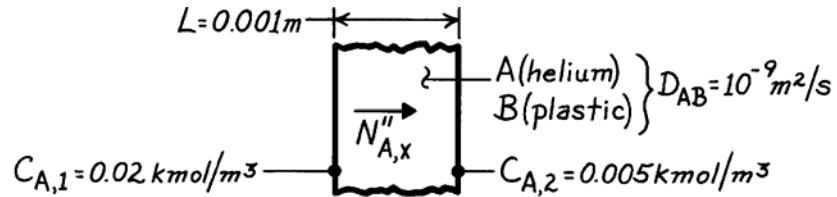

**ASSUMPTIONS:** (1) Steady-state conditions, (2) One-dimensional diffusion in a plane wall, (3) Stationary medium, (4) Uniform  $C = C_A + C_B$ .

**ANALYSIS:** The molar flux may be obtained from Eq. 14.54,

$$N''_{A,x} = \frac{D_{AB}}{L} (C_{A,1} - C_{A,2}) = \frac{10^{-9} \text{ m}^2/\text{s}}{0.001 \text{ m}} (0.02 - 0.005) \text{ kmol/m}^3$$

$$N''_{A,x} = 1.5 \times 10^{-8} \text{ kmol/s} \cdot \text{m}^2.$$

<

**COMMENTS:** The mass flux is

$$n''_{A,x} = \mathcal{M}_A N''_{A,x} = 4 \text{ kg/kmol} \times 1.5 \times 10^{-8} \text{ kmol/s} \cdot \text{m}^2 = 6 \times 10^{-8} \text{ kg/s} \cdot \text{m}^2.$$

### PROBLEM 14.16

**KNOWN:** Three-dimensional diffusion of species A in a stationary medium with chemical reactions.

**FIND:** Derive molar form of diffusion equation.

**SCHEMATIC:**

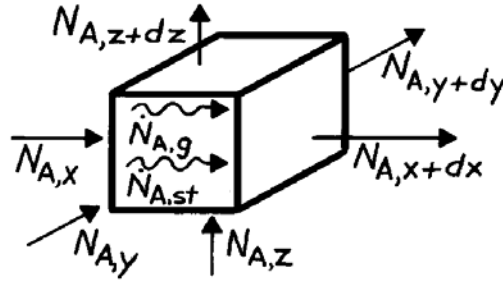

**ASSUMPTIONS:** (1) Uniform total molar concentration, (2) Stationary medium.

**ANALYSIS:** The derivation parallels that of Section 14.4.2, except that Eq. 14.43 is applied on a molar basis. That is,

$$N_{A,x} + N_{A,y} + N_{A,z} + \dot{N}_{A,g} - N_{A,x+dx} - N_{A,y+dy} - N_{A,z+dz} = \dot{N}_{A,st}$$

With

$$N_{A,x+dx} = N_{A,x} + \frac{\partial N_{A,x}}{\partial x} dx, \quad N_{A,y+dy} = \dots$$

$$N_{A,x} = -D_{AB} (dydz) \frac{\partial C_A}{\partial x}, \quad N_{A,y} = \dots$$

$$\dot{N}_{A,g} = \dot{N}_A (dxdydz), \quad \dot{N}_{A,st} = \frac{\partial C_A}{\partial t} dxdydz$$

It follows that

$$\frac{\partial}{\partial x} \left( D_{AB} \frac{\partial C_A}{\partial x} \right) + \frac{\partial}{\partial y} \left( D_{AB} \frac{\partial C_A}{\partial y} \right) + \frac{\partial}{\partial z} \left( D_{AB} \frac{\partial C_A}{\partial z} \right) + \dot{N}_A = \frac{\partial C_A}{\partial t}. \quad <$$

**COMMENTS:** If  $D_{AB}$  is constant, the foregoing result reduces to Eq. 14.48b.



### PROBLEM 14.17

**KNOWN:** Gas (A) diffuses through a cylindrical tube wall (B) and experiences chemical reactions at a volumetric rate,  $\dot{N}_A$ .

**FIND:** Differential equation which governs molar concentration of gas in plastic.

**SCHEMATIC:**



**ASSUMPTIONS:** (1) One-dimensional radial diffusion, (2) Uniform total molar concentration, (3) Stationary medium.

**ANALYSIS:** Dividing the species conservation requirement, Eq. 14.43, by the molecular weight,  $\mathcal{M}_A$ , and applying it to a differential control volume of unit length normal to the page,

$$N_{A,r} + \dot{N}_{A,g} - N_{A,r+dr} = \dot{N}_{A,st}$$

where

$$N_{A,r} = (2\pi r \cdot 1) N''_{A,r} = -2\pi r D_{AB} \frac{\partial C_A}{\partial r}$$

$$N_{A,r+dr} = N_{A,r} + \frac{\partial N_{A,r}}{\partial r} dr$$

$$\dot{N}_{A,g} = -\dot{N}_A (2\pi r \cdot dr \cdot 1) \qquad \dot{N}_{A,st} = \frac{\partial [C_A (2\pi r dr \cdot 1)]}{\partial t}$$

Hence

$$-\dot{N}_A (2\pi r dr) + 2\pi D_{AB} \frac{\partial}{\partial r} \left( r \frac{\partial C_A}{\partial r} \right) dr = 2\pi r dr \frac{\partial C_A}{\partial t}$$

or

$$\frac{D_{AB}}{r} \frac{\partial}{\partial r} \left( r \frac{\partial C_A}{\partial r} \right) - \dot{N}_A = \frac{\partial C_A}{\partial t} \qquad <$$

**COMMENTS:** (1) The minus sign in the generation term is necessitated by the fact that the reactions deplete the concentration of species A.

(2) From knowledge of  $\dot{N}_A (r, t)$ , the foregoing equation could be solved for  $C_A (r, t)$ .

(3) Note the agreement between the above result and the one-dimensional form of Eq. 14.49 for uniform C.

### PROBLEM 14.18

**KNOWN:** One-dimensional, radial diffusion of species A in a stationary, spherical medium with chemical reactions.

**FIND:** Derive appropriate form of diffusion equation.

**SCHEMATIC:**

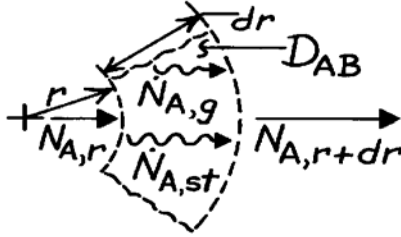

**ASSUMPTIONS:** (1) One-dimensional, radial diffusion, (2) Uniform total molar concentration, (3) Stationary medium.

**ANALYSIS:** Dividing the species conservation requirement, Eq. 14.43, by the molecular weight,  $\mathcal{M}_A$ , and applying it to the differential control volume, it follows that

$$N_{A,r} + \dot{N}_{A,g} - N_{A,r+dr} = \dot{N}_{A,st}$$

where

$$N_{A,r} = -D_{AB} 4\pi r^2 \frac{\partial C_A}{\partial r}$$

$$N_{A,r+dr} = N_{A,r} + \frac{\partial N_{A,r}}{\partial r} dr$$

$$\dot{N}_{A,g} = \dot{N}_A (4\pi r^2 dr), \quad \dot{N}_{A,st} = \frac{\partial [C_A (4\pi r^2 dr)]}{\partial t}$$

Hence

$$\dot{N}_A (4\pi r^2 dr) + 4\pi \frac{\partial}{\partial r} \left( D_{AB} r^2 \frac{\partial C_A}{\partial r} \right) dr = 4\pi r^2 \frac{\partial C_A}{\partial t} dr$$

or

$$\frac{1}{r^2} \frac{\partial}{\partial r} \left( D_{AB} r^2 \frac{\partial C_A}{\partial r} \right) + \dot{N}_A = \frac{\partial C_A}{\partial t}. \quad <$$

**COMMENTS:** Equation 14.50 reduces to the foregoing result if C is independent of r and variations in  $\phi$  and  $\theta$  are negligible.

### PROBLEM 14.19

**KNOWN:** Pressure and temperature of hydrogen stored in a spherical steel tank of prescribed diameter and thickness.

**FIND:** (a) Initial rate of hydrogen mass loss from the tank, (b) Initial rate of pressure drop in the tank.

**SCHEMATIC:**

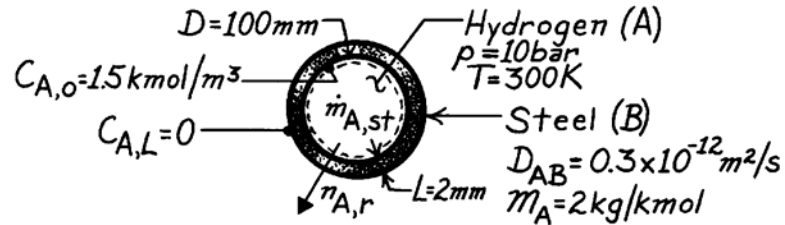

**ASSUMPTIONS:** (1) One-dimensional species diffusion in a stationary medium, (2) Uniform total molar concentration,  $C$ , (3) No chemical reactions.

**ANALYSIS:** (a) From Table 14.1

$$N_{A,r} = \frac{C_{A,o} - C_{A,L}}{R_{m,dif}} = \frac{C_{A,o}}{(1/4\pi D_{AB})(1/r_i - 1/r_o)}$$

$$N_{A,r} = \frac{4\pi(0.3 \times 10^{-12} \text{ m}^2/\text{s})1.5 \text{ kmol/m}^3}{(1/0.05 \text{ m} - 1/0.052 \text{ m})} = 7.35 \times 10^{-12} \text{ kmol/s}$$

or

$$n_{A,r} = M_A N_{A,r} = 2 \text{ kg/kmol} \times 7.35 \times 10^{-12} \text{ kmol/s} = 14.7 \times 10^{-12} \text{ kg/s.} \quad <$$

(b) Applying a species balance to a control volume about the hydrogen,

$$\dot{M}_{A,st} = -\dot{M}_{A,out} = -n_{A,r}$$

$$\dot{M}_{A,st} = \frac{d(\rho_A V)}{dt} = \frac{\pi D^3}{6} \frac{d\rho_A}{dt} = \frac{\pi D^3}{6R_A T} \frac{dp_A}{dt} = \frac{\pi D^3 M_A}{6RT} \frac{dp_A}{dt}$$

Hence

$$\frac{dp_A}{dt} = -\frac{6RT}{\pi D^3 M_A} n_{A,r} = -\frac{6(0.08314 \text{ m}^3 \cdot \text{bar/kmol} \cdot \text{K})(300 \text{ K})}{\pi(0.1 \text{ m})^3 2 \text{ kg/kmol}} \times 14.7 \times 10^{-12} \text{ kg/s}$$

$$\frac{dp_A}{dt} = -3.50 \times 10^{-7} \text{ bar/s.} \quad <$$

**COMMENTS:** If the spherical shell is approximated as a plane wall,  $N_{a,x} = D_{AB}(C_{A,o}) \pi D^2/L = 7.07 \times 10^{-12} \text{ kmol/s}$ . This result is 4% lower than that associated with the spherical shell calculation.

## PROBLEM 14.20

**KNOWN:** Temperature of atmospheric air and water. Percentage by volume of oxygen in the air.

**FIND:** (a) Mole and mass fractions of water at the air and water sides of the interface, (b) Mole and mass fractions of oxygen in the air and water.

**SCHEMATIC:**

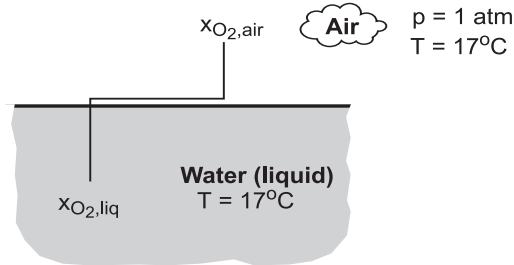

$$M_w = 18, M_{air} = 29$$

**ASSUMPTIONS:** (1) Perfect gas behavior for air and water vapor, (2) Thermodynamic equilibrium at liquid/vapor interface, (3) Dilute concentration of oxygen and other gases in water, (4) Molecular weight of air is independent of vapor concentration.

**PROPERTIES:** Table A-6, Saturated water ( $T = 290 \text{ K}$ ):  $p_{\text{vap}} = 0.01917 \text{ bars}$ . Table A-9,  $\text{O}_2/\text{water}$ ,  $H = 37,600 \text{ bars}$ .

**ANALYSIS:** (a) Assuming ideal gas behavior,  $p_{w,\text{vap}} = (N_{w,\text{vap}}/V) \mathcal{R}T$  and  $p = (N/V) \mathcal{R}T$ , in which case

$$x_{w,\text{vap}} = (p_{w,\text{vap}} / p_{\text{air}}) = (0.01917 / 1.0133) = 0.0189 \quad <$$

With  $m_{w,\text{vap}} = (\rho_{w,\text{vap}}/\rho_{\text{air}}) = (C_{w,\text{vap}} M_w / C_{\text{air}} M_{\text{air}}) = x_{w,\text{vap}} (M_w / M_{\text{air}})$ . Hence,

$$m_{w,\text{vap}} = 0.0189 (18/29) = 0.0120 \quad <$$

Assuming negligible gas phase concentrations in the liquid,

$$x_{w,\text{liq}} = m_{w,\text{liq}} = 1 \quad <$$

(b) Since the partial volume of a gaseous species is proportional to the number of moles of the species, its mole fraction is equivalent to its volume fraction. Hence on the air side of the interface

$$x_{\text{O}_2,\text{air}} = 0.205 \quad <$$

$$m_{\text{O}_2,\text{air}} = x_{\text{O}_2,\text{air}} (M_{\text{O}_2} / M_{\text{air}}) = 0.205 (32/29) = 0.226 \quad <$$

The mole fraction of  $\text{O}_2$  in the water is

$$x_{\text{O}_2,\text{liq}} = p_{\text{O}_2,\text{air}} / H = 0.208 \text{ bars} / 37,600 \text{ bars} = 5.53 \times 10^{-6} \quad <$$

where  $p_{\text{O}_2,\text{air}} = x_{\text{O}_2,\text{air}} p_{\text{atm}} = 0.205 \times 1.0133 \text{ bars} = 0.208 \text{ bars}$ . The mass fraction of  $\text{O}_2$  in the water is

$$m_{\text{O}_2,\text{liq}} = x_{\text{O}_2,\text{liq}} (M_{\text{O}_2} / M_w) = 5.53 \times 10^{-6} (32/18) = 9.83 \times 10^{-6} \quad <$$

**COMMENTS:** There is a large discontinuity in the oxygen content between the air and water sides of the interface. Despite the low concentration of oxygen in the water, it is sufficient to support the life of aquatic organisms.

### PROBLEM 14.21

**KNOWN:** Pressure and temperature of hydrogen inside and outside of a circular tube. Diffusivity and solubility of hydrogen in tube wall of prescribed thickness and diameter.

**FIND:** Rate of hydrogen transfer through tube per unit length.

**SCHEMATIC:**

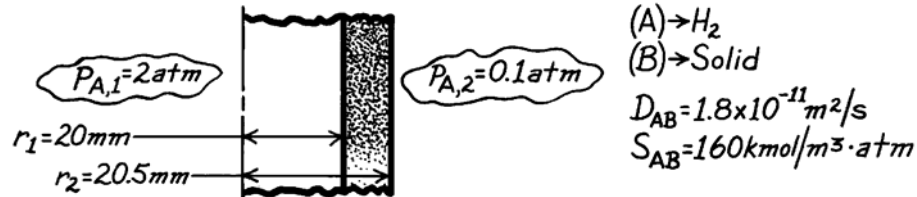

**ASSUMPTIONS:** (1) Steady diffusion in radial direction, (2) Uniform total molar concentration in wall, (3) No chemical reactions, (4) Stationary medium.

**ANALYSIS:** The mass transfer rate per unit tube length is

$$N'_{A,r} = \frac{C_A(r_1) - C_A(r_2)}{\ln(r_2/r_1) / 2\pi D_{AB}}$$

where from Eq. 14.62,  $C_{A,s} = S p_a$ ,

$$C_A(r_1) = S p_{A,1} = 160 \text{ kmol/m}^3 \cdot \text{atm} \times 2 \text{ atm} = 320 \text{ kmol/m}^3$$

$$C_A(r_2) = S p_{A,2} = 160 \text{ kmol/m}^3 \cdot \text{atm} \times 0.1 \text{ atm} = 16 \text{ kmol/m}^3.$$

Hence,

$$N'_{A,r} = \frac{(320 - 16) \text{ kmol/m}^3}{\ln(20.5/20) / 2\pi \times 1.8 \times 10^{-11} \text{ m}^2/\text{s}} = \frac{304 \text{ kmol/m}^3}{2.18 \times 10^8 \text{ s/m}^2}$$

$$N'_{A,r} = 1.39 \times 10^{-6} \text{ kmol/s} \cdot \text{m}.$$

<

**COMMENTS:** If the wall were assumed to be plane,

$$R'_{m,dif} = \frac{L}{D_{AB}\pi D} = \frac{5 \times 10^{-4} \text{ m}}{1.8 \times 10^{-11} \text{ m}^2/\text{s} \pi (0.04 \text{ m})} = 2.21 \times 10^8 \text{ s/m}^2$$

which is close to the value of  $2.18 \times 10^8 \text{ s/m}^2$  for the cylindrical wall.

### PROBLEM 14.22

**KNOWN:** Oxygen pressures on opposite sides of a rubber membrane.

**FIND:** (a) Molar diffusion flux of O<sub>2</sub>, (b) Molar concentrations of O<sub>2</sub> outside the rubber.

**SCHEMATIC:**

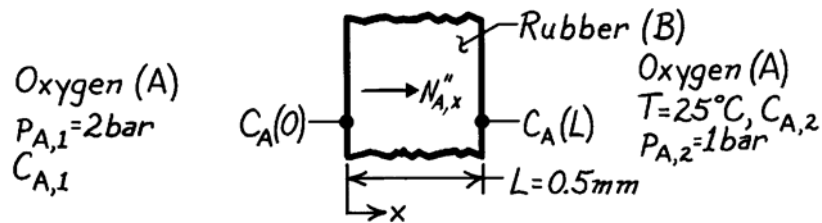

**ASSUMPTIONS:** (1) One-dimensional, steady-state conditions, (2) Stationary medium of uniform total molar concentration,  $C = C_A + C_B$ , (3) Perfect gas behavior.

**PROPERTIES:** Table A-8, Oxygen-rubber (298 K):  $D_{AB} = 0.21 \times 10^{-9} \text{ m}^2/\text{s}$ ; Table A-10, Oxygen-rubber (298 K):  $S = 3.12 \times 10^{-3} \text{ kmol/m}^3 \cdot \text{bar}$ .

**ANALYSIS:** (a) For the assumed conditions

$$N''_{A,x} = J''_{A,x} = -D_{AB} \frac{dC_A}{dx} = D_{AB} \frac{C_A(0) - C_A(L)}{L}$$

From Eq. 14.62,

$$C_A(0) = S p_{A,1} = 6.24 \times 10^{-3} \text{ kmol/m}^3$$

$$C_A(L) = S p_{A,2} = 3.12 \times 10^{-3} \text{ kmol/m}^3$$

Hence

$$N''_{A,x} = 0.21 \times 10^{-9} \text{ m}^2/\text{s} \frac{(6.24 \times 10^{-3} - 3.12 \times 10^{-3}) \text{ kmol/m}^3}{0.0005 \text{ m}}$$

$$N''_{A,x} = 1.31 \times 10^{-9} \text{ kmol/s} \cdot \text{m}^2 \quad <$$

(b) From the perfect gas law

$$C_{A,1} = \frac{p_{A,1}}{\mathcal{R}T} = \frac{2 \text{ bar}}{(0.08314 \text{ m}^3 \cdot \text{bar}/\text{kmol} \cdot \text{K}) 298 \text{ K}} = 0.0807 \text{ kmol/m}^3 \quad <$$

$$C_{A,2} = 0.5 C_{A,1} = 0.0404 \text{ kmol/m}^3 \quad <$$

**COMMENTS:** Recognize that the molar concentrations outside the membrane differ from those within the membrane; that is,  $C_{A,1} \neq C_A(0)$  and  $C_{A,2} \neq C_A(L)$ .

### PROBLEM 14.23

**KNOWN:** Water vapor is transferred through dry wall by diffusion.

**FIND:** The mass diffusion rate through a  $0.01 \times 3 \times 5$  m wall.

**SCHEMATIC:**

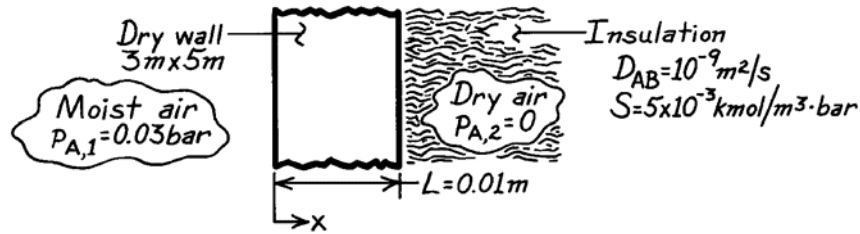

**ASSUMPTIONS:** (1) Steady-state conditions, (2) One-dimensional species diffusion, (3) Homogeneous medium, (4) Constant properties, (5) Uniform total molar concentration, (6) Stationary medium with  $x_A \ll 1$ , (7) Negligible condensation in the dry wall.

**ANALYSIS:** From Eq. 14.42,

$$N''_{A,x} = -CD_{AB} \frac{dx_A}{dx} = -D_{AB} \frac{dC_A}{dx} = D_{AB} \frac{C_{A,1} - C_{A,2}}{L}.$$

From Eq. 14.62

$$C_{A,1} = Sp_{A,1} = 0.15 \times 10^{-3} \text{ kmol/m}^3$$

$$C_{A,2} = Sp_{A,2} = 0 \text{ kmol/m}^3.$$

Hence

$$N''_A = 10^{-9} \text{ m}^2/\text{s} \times \frac{0.15 \times 10^{-3} \text{ kmol/m}^3}{0.01 \text{ m}} = 0.15 \times 10^{-10} \text{ kmol/s} \cdot \text{m}^2.$$

Therefore

$$n_A = \mathcal{M}_A (A \cdot N''_A) = 18 \text{ kg/kmol} \times 15 \text{ m}^2 \times 0.15 \times 10^{-10} \text{ kmol/s} \cdot \text{m}^2$$

or

$$n_A = 4.05 \times 10^{-9} \text{ kg/s.}$$

<

### PROBLEM 14.24

**KNOWN:** Pressure and temperature of helium in a glass cylinder of 100 mm inside diameter and 5 mm thickness.

**FIND:** Mass rate of helium loss per unit length.

**SCHEMATIC:**

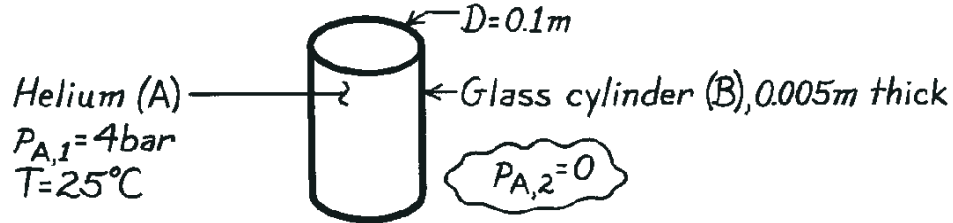

**ASSUMPTIONS:** (1) Steady-state conditions, (2) One-dimensional radial diffusion through cylinder wall, (3) Negligible end losses, (4) Stationary medium, (5) Uniform total molar concentration, (6) Negligible helium concentration outside cylinder.

**PROPERTIES:** Table A-8, He-SiO<sub>2</sub> (298 K):  $D_{AB} \approx 0.4 \times 10^{-13} \text{ m}^2/\text{s}$ ; Table A-10, He-SiO<sub>2</sub> (298 K):  $S \approx 0.45 \times 10^{-3} \text{ kmol}/\text{m}^3 \cdot \text{bar}$ .

**ANALYSIS:** From Table 14.1,

$$N'_{A,r} = \frac{C_{A,S1} - C_{A,S2}}{\ln(r_2/r_1)/2\pi D_{AB}}$$

where, from Eq. 14.62,  $C_{A,S} = Sp_A$ . Hence

$$C_{A,S1} = Sp_{A,1} = 0.45 \times 10^{-3} \text{ kmol}/\text{m}^3 \cdot \text{bar} \times 4 \text{ bar} = 1.8 \times 10^{-3} \text{ kmol}/\text{m}^3$$

$$C_{A,S2} = Sp_{A,2} = 0.$$

Hence

$$N'_{A,r} = \frac{1.8 \times 10^{-3} \text{ kmol}/\text{m}^3}{\ln(0.055/0.050)/2\pi(0.4 \times 10^{-13} \text{ m}^2/\text{s})}$$

$$N'_{A,r} = 4.75 \times 10^{-15} \text{ kmol}/\text{s} \cdot \text{m}.$$

The mass loss is then

$$n'_{A,r} = \mathcal{M}_A N'_{A,r} = 4 \text{ kg}/\text{kmol} \times 4.75 \times 10^{-15} \text{ kmol}/\text{s} \cdot \text{m}$$

$$n'_{A,r} = 1.90 \times 10^{-14} \text{ kg}/\text{s} \cdot \text{m}.$$

<



### PROBLEM 14.25

**KNOWN:** Temperature and pressure of helium stored in a spherical pyrex container of prescribed diameter and wall thickness.

**FIND:** Mass rate of helium loss.

**SCHEMATIC:**

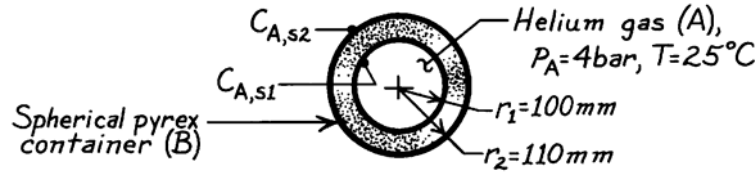

**ASSUMPTIONS:** (1) Steady-state conditions, (2) Helium loss by one-dimensional diffusion in radial direction through the pyrex, (3)  $C = C_A + C_B$  is independent of  $r$ , and  $x_A \ll 1$ , (4) Stationary medium.

**PROPERTIES:** Table A-8, He-SiO<sub>2</sub> (293 K):  $D_{AB} = 0.4 \times 10^{-13} \text{ m}^2/\text{s}$ ; Table A-10, He-SiO<sub>2</sub> (293 K):  $S = 0.45 \times 10^{-3} \text{ kmol/m}^3 \cdot \text{bar}$ .

**ANALYSIS:** From Table 14.1, the molar diffusion rate may be expressed as

$$N_{A,r} = \frac{C_{A,S1} - C_{A,S2}}{R_{m,dif}}$$

where

$$R_{m,dif} = \frac{1}{4\pi D_{AB}} \left( \frac{1}{r_1} - \frac{1}{r_2} \right) = \frac{1}{4\pi (0.4 \times 10^{-13} \text{ m}^2/\text{s})} \left( \frac{1}{0.1 \text{ m}} - \frac{1}{0.11 \text{ m}} \right) = 1.81 \times 10^{12} \text{ s/m}^3$$

with

$$C_{A,S1} = S p_A = 0.45 \times 10^{-3} \text{ kmol/m}^3 \cdot \text{bar} \times 4 \text{ bar} = 1.80 \times 10^{-3} \text{ kmol/m}^3$$

$$C_{A,S2} = 0$$

find

$$N_{A,r} = \frac{1.80 \times 10^{-3} \text{ kmol/m}^3}{1.81 \times 10^{12} \text{ s/m}^3} = 10^{-15} \text{ kmol/s.}$$

Hence

$$n_{A,r} = \mathcal{M}_A N_{A,r} = 4 \text{ kg/mol} \times 10^{-15} \text{ kmol/s} = 4 \times 10^{-15} \text{ kg/s.} \quad <$$

**COMMENTS:** Since  $r_1 \approx r_2$ , the spherical shell could have been approximated as a plane wall with  $L = 0.01 \text{ m}$  and  $A \approx 4\pi r_m^2 = 0.139 \text{ m}^2$ . From Table 14.1,

$$R_{m,dif} = \frac{L}{D_{AB} A} = \frac{0.01 \text{ m}}{(0.4 \times 10^{-13} \text{ m}^2/\text{s})(0.137 \text{ m}^2)} = 1.8 \times 10^{12} \text{ s/m}^3 \text{ and}$$

$$N_{A,x} = \frac{C_{A,S1} - C_{A,S2}}{R_{m,dif}} = \frac{1.80 \times 10^{-3} \text{ kmol/m}^3}{1.8 \times 10^{12} \text{ s/m}^3} = 10^{-15} \text{ kmol/s.}$$

Hence the approximation is excellent.

## PROBLEM 14.26

**KNOWN:** Thickness of polymer packaging material, temperature and humidity conditions in gas on either side of the material.

**FIND:** (a) Solubility of the packaging material, (b) Total water vapor transfer rate for a material that has 10% of the diffusivity of the material in Example 14.3, (c) Total water vapor transfer rate for a material that has 10% the solubility of the material in Example 14.3, (d) Total water vapor transfer rate after coating the exterior surface with a thin film to reduce its solubility by a factor of 9, leaving the interior surface untreated.

**SCHEMATIC:**

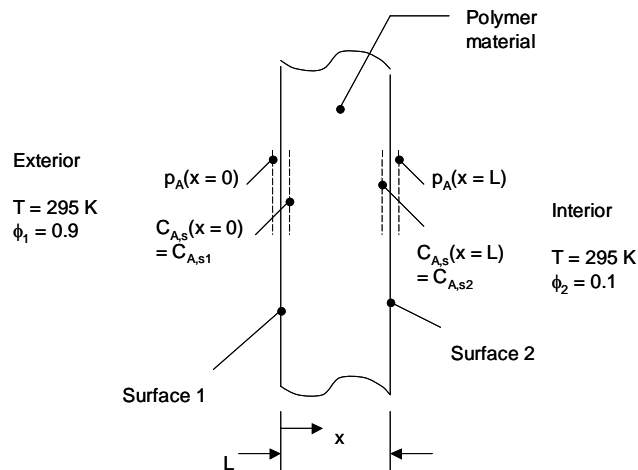

**ASSUMPTIONS:** (1) Constant properties and steady-state conditions, (2) Stationary medium.

**PROPERTIES:** Table A.6, water ( $T = 295 \text{ K}$ ):  $p_{\text{sat}} = 0.02617 \text{ bars}$ .

**ANALYSIS:**

(a) For the exterior Surface 1,  $p_A(x=0) = \phi_1 p_{A,\text{sat}} = 0.9 \times 0.02617 \text{ bars} = 0.02355 \text{ bars}$ . For the interior Surface 2,  $p_A(x=L) = \phi_2 p_{A,\text{sat}} = 0.1 \times 0.02617 \text{ bars} = 0.002617 \text{ bars}$ . From Example 14.3,  $C_{A,s2} = C_{A,s}(x=L) = 0.5 \times 10^{-3} \text{ kmol/m}^3$  so that

$$S = \frac{C_{A,s2}}{p_A(x=L)} = \frac{0.5 \times 10^{-3} \text{ kmol/m}^3}{0.002617 \text{ bar}} = 191 \times 10^{-3} \frac{\text{kmol}}{\text{m}^3 \text{bar}} \quad <$$

(b) From Example 14.3,  $N_{A,x,p} = 0.32 \times 10^{-15} \text{ kmol/s}$ . If the diffusivity is reduced to 10% of its original value,

$$N_{A,x} = 0.1 N_{A,x,p} = 0.1 \times 0.32 \times 10^{-15} \text{ kmol/s} = 0.32 \times 10^{-16} \text{ kmol/s} \quad <$$

Continued...

### PROBLEM 14.26 (Cont.)

(c) If the solubility is reduced to 10% of its original value at both surfaces,  $C_{A,s1} = 0.5 \times 10^{-4} \text{ kmol/m}^3$  and  $C_{A,s2} = 4.5 \times 10^{-4} \text{ kmol/m}^3$ . Hence,

$$N_{A,x} = 0.1N_{A,x,p} = 0.32 \times 10^{-16} \text{ kmol/s} \quad <$$

(d) If the solubility of exterior Surface 1 is reduced by a factor of 9,  $C_{A,s1} = C_{A,s1,p}/9 = 4.5 \times 10^{-3} \text{ kmol/m}^3/9 = 0.5 \times 10^{-3} \text{ kmol/m}^3 = C_{A,s2}$ . Hence,

$$C_{A,s1} - C_{A,s2} = 0 \text{ and } N_{A,x} = 0 \quad <$$

**COMMENT:** (1) The same value of the solubility may be found in part (a) by considering conditions at Surface 1. (2) By manipulating the solubilities of the surfaces independently, one may eliminate concentration gradients in the material and, in turn, completely eliminate water vapor transfer by diffusion. Materials that have properties designed to change through their thickness in order to promote desired behavior are known as *functionally-graded* materials.

## PROBLEM 14.27

**KNOWN:** Dimensions of sphere containing a pharmaceutical product. Mass loss of sphere over specified time period, mass diffusivity, external conditions.

**FIND:** The value of the partition coefficient,  $K$ .

**SCHEMATIC:**

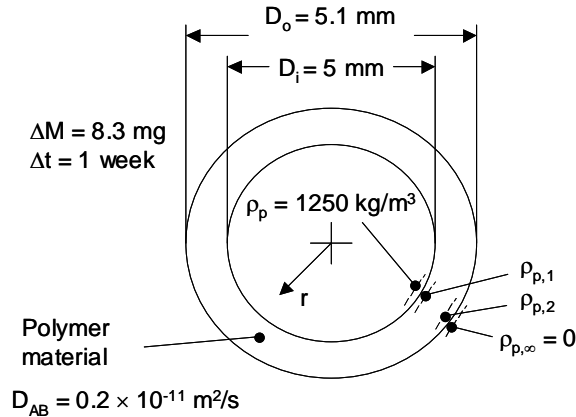

**ASSUMPTIONS:** (1) Constant properties and steady-state conditions, (2) Stationary medium.

**PROPERTIES:** Pharmaceutical product (given):  $\rho_p = 1250 \text{ kg/m}^3$ ,  $D_{AB} = 0.2 \times 10^{-11} \text{ m}^2/\text{s}$ ,

**ANALYSIS:** By the definition of the partition coefficient provided in the problem statement,

$\rho_{p,1} = K\rho_p$  and  $\rho_{p,2} = K\rho_{p,\infty}$ . The mass transfer rate through the polymer is found using the one-dimensional species diffusion resistance approach

$$n_{p,r} = \frac{\rho_{p,1} - \rho_{p,2}}{R_{m,dif}} = \frac{K\rho_p}{\frac{1}{4\pi D_{AB}} \left( \frac{1}{r_1} - \frac{1}{r_2} \right)} = \frac{\Delta M}{\Delta t}$$

Hence,

$$K = \frac{\Delta M}{\Delta t \rho_p} \left[ \frac{1}{4\pi D_{AB}} \left( \frac{1}{r_1} - \frac{1}{r_2} \right) \right]$$

$$= \frac{8.2 \times 10^{-6} \text{ kg}}{7 \text{ days} \times 24 \text{ h/day} \times 3600 \text{ s/h} \times 1250 \text{ kg/m}^3} \times \left[ \frac{1}{4\pi \times 0.2 \times 10^{-11} \text{ m}^2/\text{s}} \left( \frac{2}{5 \times 10^{-3} \text{ m}} - \frac{2}{5.1 \times 10^{-3} \text{ m}} \right) \right]$$

$$= 0.0034$$

<

## PROBLEM 14.28

**KNOWN:** Dimensions of  $N = 100$  closed-end palladium tubes. Hydrogen ( $H_2$ ) pressures and temperature on either side of tube wall. Mass diffusivity of atomic hydrogen (H) through the palladium, and Sievert's constant.

**FIND:** Hourly production rate of pure hydrogen ( $H_2$ ).

**SCHEMATIC:**

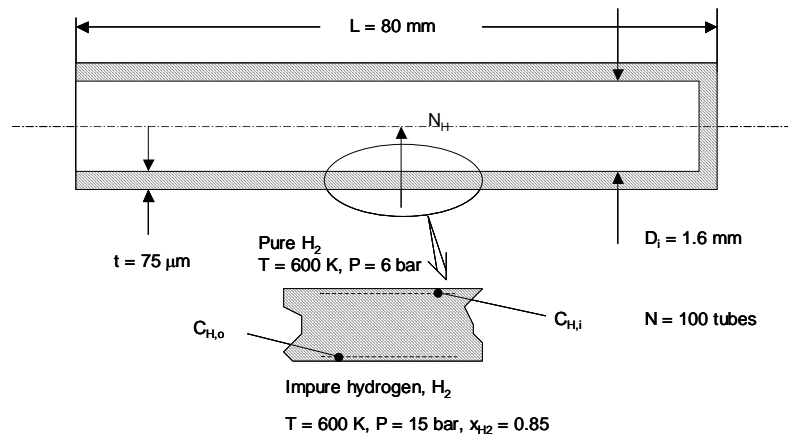

**ASSUMPTIONS:** (1) Constant properties and steady-state conditions, (2) Stationary medium.

**PROPERTIES:** Hydrogen (H) in palladium, given:  $D_{AB} = 7 \times 10^{-9} \text{ m}^2/\text{s}$ .

**ANALYSIS:** The concentration of atomic hydrogen (H) on the outer and inner surfaces of the tube are

$$C_{H,o} = 1.4 \frac{\text{kmol}}{\text{m}^3 \text{bar}^{1/2}} \times (0.85 \times 15 \text{ bar})^{1/2} = 5.00 \text{ kmol/m}^3$$

and

$$C_{H,i} = 1.4 \frac{\text{kmol}}{\text{m}^3 \text{bar}^{1/2}} \times (6 \text{ bar})^{1/2} = 3.43 \text{ kmol/m}^3$$

The one-dimensional species diffusion resistances for the wall and end of one tube are

$$R_{m,dif,w} = \frac{\ln(r_2/r_1)}{2\pi L D_{AB}} = \frac{\ln[(0.8 \times 10^{-3} \text{ m} + 75 \times 10^{-6} \text{ m})/0.8 \times 10^{-3} \text{ m}]}{2\pi \times 80 \times 10^{-3} \text{ m} \times 7 \times 10^{-9} \text{ m}^2/\text{s}} = 25.5 \times 10^6 \text{ s/m}^3$$

and

$$R_{m,dif,e} = \frac{t}{D_{AB} A_c} = \frac{75 \times 10^{-6} \text{ m}}{7 \times 10^{-9} \text{ m}^2/\text{s} \times \pi \times (0.8 \times 10^{-3} \text{ m})^2} = 5.33 \times 10^9 \text{ s/m}^3$$

The molar transfer rate of atomic hydrogen (H) in one tube is therefore

Continued...

### PROBLEM 14.28 (Cont.)

$$N_H = \frac{(5.00 - 3.43) \frac{\text{kmol}}{\text{m}^3}}{25.5 \times 10^6 \frac{\text{s}}{\text{m}^3}} + \frac{(5.00 - 3.43) \frac{\text{kmol}}{\text{m}^3}}{5.33 \times 10^9 \frac{\text{s}}{\text{m}^3}} = 61.9 \times 10^{-9} \frac{\text{kmol}}{\text{s}}$$

The molar transfer rate of molecular hydrogen ( $\text{H}_2$ ) is therefore  $N_{\text{H}_2} = 0.5N_H = 30.95 \text{ kmol/s}$

The total production rate,  $N_{\text{H}_2,t}$ , in kg/h is

$$N_{\text{H}_2,t} = N_{\text{H}_2} \times \mathcal{M}_{\text{H}_2} \times N \times t = 30.95 \text{ kmol/s} \times 2 \text{ kg/kmol} \times 3600 \text{ s/h} \times 100 \text{ tubes} = 0.022 \text{ kg/h} \quad <$$

**Comments:** (1) The concentrations of hydrogen ( $\text{H}_2$ ) in the gas streams are  $0.25 \text{ kmol/m}^3$  and  $0.12 \text{ kmol/m}^3$ , respectively. (2) Palladium and other nanostructured materials, such as carbon nanotubes, can store very high concentrations of hydrogen within their atomic matrix.

### PROBLEM 14.29

**KNOWN:** Conditions of the exhaust gas passing over a catalytic surface for the removal of NO.

**FIND:** (a) Mole fraction of NO at the catalytic surface, (b) NO removal rate.

**SCHEMATIC:**

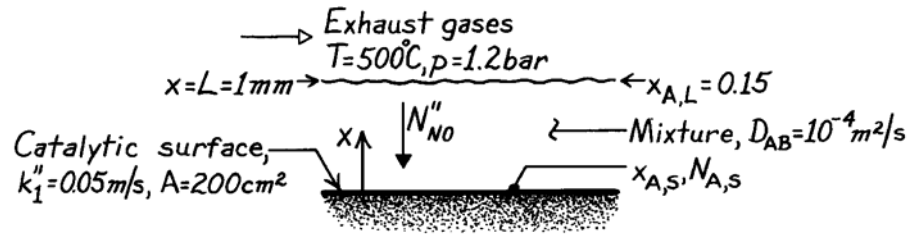

**ASSUMPTIONS:** (1) Steady-state conditions, (2) One-dimensional species diffusion through the film, (3) Effects of bulk motion on NO transfer in the film are negligible (stationary medium), (4) No homogeneous reactions of NO within the film, (5) Constant properties, including the total molar concentration,  $C$ , throughout the film.

**ANALYSIS:** Subject to the above assumptions, the transfer of species A (NO) is governed by diffusion in a stationary medium, and the desired results are obtained from Eqs. 14.69 and 14.70.

Hence

$$\frac{x_{A,s}}{x_{A,L}} = \frac{1}{1 + (Lk_1''/D_{AB})} \quad x_{A,s} = \frac{0.15}{1 + 0.001 \text{ m} \times 0.05 \text{ m/s} / 10^{-4} \text{ m}^2/\text{s}} = 0.10. <$$

Also

$$N_{A,s}'' = -\frac{k_1'' C x_{A,L}}{1 + (Lk_1''/D_{AB})}$$

where, from the equation of state for a perfect gas,

$$C = \frac{p}{RT} = \frac{1.2 \text{ bar}}{8.314 \times 10^{-2} \text{ m}^3 \cdot \text{bar} / \text{kmol} \cdot \text{K} \times 773 \text{ K}} = 0.0187 \text{ kmol} / \text{m}^3.$$

Hence

$$N_{A,s}'' = -\frac{0.05 \text{ m/s} \times 0.0187 \text{ kmol} / \text{m}^3 \times 0.15}{1 + (0.001 \text{ m} \times 0.05 \text{ m/s} / 10^{-4} \text{ m}^2/\text{s})} = -9.35 \times 10^{-5} \text{ kmol} / \text{s} \cdot \text{m}^2$$

or

$$n_{A,s}'' = \mathcal{M}_A N_{A,s}'' = 30 \text{ kg} / \text{kmol} \left( -9.35 \times 10^{-5} \text{ kmol} / \text{s} \cdot \text{m}^2 \right) = -2.80 \times 10^{-3} \text{ kg} / \text{s} \cdot \text{m}^2.$$

The molar rate of NO removal for the entire surface is then

$$N_{A,s} = N_{A,s}'' A = -9.35 \times 10^{-5} \text{ kmol} / \text{s} \cdot \text{m}^2 \times 0.02 \text{ m}^2 = -1.87 \times 10^{-6} \text{ kmol} / \text{s}$$

or

$$n_{A,s} = -5.61 \times 10^{-5} \text{ kg} / \text{s}. <$$

**COMMENTS:** Because bulk motion is likely to contribute significantly to NO transfer within the film, the above results should be viewed as a first approximation.

### PROBLEM 14.30

**KNOWN:** Radius of coal pellets burning in oxygen atmosphere of prescribed pressure and temperature.

**FIND:** Oxygen molar consumption rate.

**SCHEMATIC:**

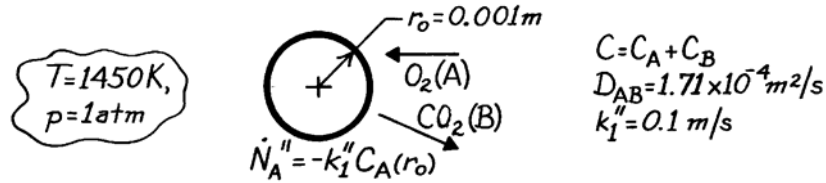

**ASSUMPTIONS:** (1) One-dimensional diffusion in  $r$ , (2) Steady-state conditions, (3) Constant properties, (4) Perfect gas behavior, (5) Uniform  $C$  and  $T$ , (6) Stationary medium.

**ANALYSIS:** From Equation 14.57,

$$\frac{d}{dr} \left( r^2 \frac{dC_A}{dr} \right) = 0$$

$$dC_A / dr = C_1 / r^2 \quad \text{or} \quad C_A = -C_1 / r + C_2.$$

The boundary conditions at  $r \rightarrow \infty$  and  $r = r_0$  are, respectively,

$$C_A(\infty) = C \rightarrow C_2 = C$$

$$\dot{N}_A'' = N_A''(r_0) = -CD_{AB} \left. \frac{dx_A}{dr} \right|_{r_0} = -D_{AB} \left. \frac{dC_A}{dr} \right|_{r_0}$$

Hence

$$-k_1''(-C_1/r_0 + C) = -D_{AB}C_1/r_0^2$$

$$k_1''(C_1/r_0) + D_{AB}(C_1/r_0^2) = k_1''C \quad \text{or} \quad C_1 = \frac{k_1''C}{(k_1''/r_0) + (D_{AB}/r_0^2)}.$$

The oxygen molar consumption rate is

$$N_A''(r_0) = -D_{AB} \left. \frac{dC_A}{dr} \right|_{r_0} = -D_{AB} \frac{k_1''C}{k_1''r_0 + D_{AB}}$$

where 
$$C = \frac{p}{\mathcal{R}T} = \frac{1 \text{ atm}}{(8.205 \times 10^{-2} \text{ m}^3 \cdot \text{atm} / \text{kmol} \cdot \text{K}) 1450 \text{ K}} = 8.405 \times 10^{-3} \text{ kmol} / \text{m}^3.$$

Hence,

$$N_A''(r_0) = -1.71 \times 10^{-4} \text{ m}^2 / \text{s} \frac{0.1 \text{ m} / \text{s} \times 8.405 \times 10^{-3} \text{ kmol} / \text{m}^3}{(10^{-4} + 1.71 \times 10^{-4}) \text{ m}^2 / \text{s}} = -5.30 \times 10^{-4} \text{ kmol} / \text{s} \cdot \text{m}^2$$

$$N_A(r_0) = 4\pi r_0^2 N_A''(r_0) = 4\pi (0.001 \text{ m})^2 \times 5.30 \times 10^{-4} \text{ kmol} / \text{s} \cdot \text{m}^2$$

$$N_A(r_0) = 6.66 \times 10^{-9} \text{ kmol} / \text{s}. \quad \leftarrow$$

**COMMENTS:** The  $O_2$  consumption rate would increase with increasing  $k_1''$  and approach a limiting *finite* value as  $k_1''$  approaches infinity.



### PROBLEM 14.31

**KNOWN:** Pore geometry in a catalytic reactor. Concentration of reacting species at pore opening and order of catalytic reaction.

**FIND:** (a) Differential equation which determines concentration of reacting species, (b) Distribution of reacting species concentration along the pore.

**SCHEMATIC:**

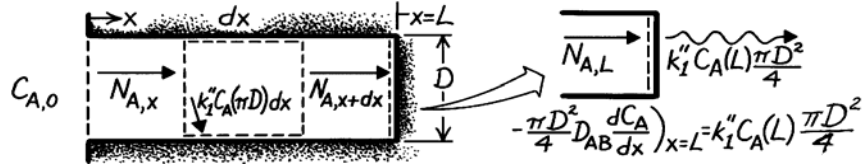

**ASSUMPTIONS:** (1) Steady-state conditions, (2) One-dimensional diffusion in x direction, (3) Stationary medium, (4) Uniform total molar concentration, (5) Stationary medium.

**ANALYSIS:** (a) Apply the species conservation requirement to the differential control volume,  $N_{A,x} - k_1'' C_A (\pi D) dx - N_{A,x+dx} = 0$ , where

$$N_{A,x+dx} = N_{A,x} + (dN_{A,x} / dx) dx$$

and from Fick's law

$$N_{A,x} = \left( -CD_{AB} \frac{dx_A}{dx} \right) \frac{\pi D^2}{4} = -\frac{\pi D^2}{4} D_{AB} \frac{dC_A}{dx}.$$

Hence

$$-\frac{dN_A}{dx} dx - k_1'' C_A (\pi D) dx = \frac{\pi D^2}{4} D_{AB} \frac{d^2 C_A}{dx^2} - k_1'' C_A (\pi D) dx = 0$$

$$\frac{d^2 C_A}{dx^2} - \frac{4k_1''}{DD_{AB}} C_A = 0. \quad \leftarrow$$

(b) A solution to the above equation is readily obtained by recognizing that it is of exactly the same form as the energy equation for an extended surface of uniform cross section. Hence for boundary conditions of the form

$$C_A(0) = C_{A,0}, \quad -D_{AB} (dC_A / dx)_{x=L} = k_1'' C_A(L)$$

the solution must be analogous to that obtained for a fin with a convection tip condition. With the analogous quantities

$$C_A \leftrightarrow \theta \equiv T - T_\infty, \quad m \equiv (4k_1'' / DD_{AB})^{1/2} \leftrightarrow (4h / Dk)^{1/2}$$

$$D_{AB} \leftrightarrow k, \quad k_1'' \leftrightarrow h$$

the solution is, by analogy to Eq. 3.75

$$C_A(x) = \frac{\cosh m(L-x) + (k_1'' / mD_{AB}) \sinh m(L-x)}{\cosh mL + (k_1'' / mD_{AB}) \sinh mL}. \quad \leftarrow$$

**COMMENTS:** The total pore reaction rate is  $-D_{AB}(\pi D^2/4) (dC_A/dx)_{x=0}$ , which can be inferred by applying the analogy to Eq. 3.76.

## PROBLEM 14.32

**KNOWN:** Pressure, temperature and mole fraction of CO in auto exhaust. Diffusion coefficient for CO in gas mixture. Film thickness and reaction rate coefficient for catalytic surface.

**FIND:** (a) Mole fraction of CO at catalytic surface and CO removal rate, (b) Effect of reaction rate coefficient on removal rate.

**SCHEMATIC:**

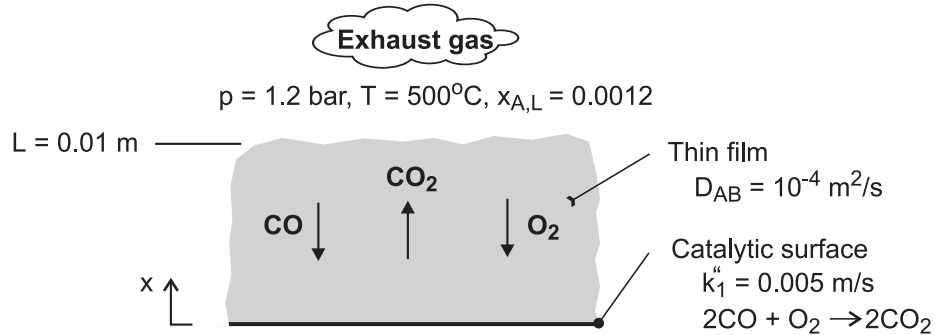

**ASSUMPTIONS:** (1) Steady-state, (2) One-dimensional species diffusion in film, (3) Negligible effect of advection in film (stationary medium), (4) Constant total molar concentration and diffusion coefficient in film.

**ANALYSIS:** From Eq. (14.69) the surface molar concentration is

$$x_A(0) = \frac{x_{A,L}}{1 + (Lk_1''/D_{AB})} = \frac{0.0012}{1 + (0.01\text{m} \times 0.005 \text{ m/s} / 10^{-4} \text{ m}^2/\text{s})} = 0.0008 \quad <$$

With  $C = p/\mathcal{R}T = 1.2 \text{ bar} / (8.314 \times 10^{-2} \text{ m}^3 \cdot \text{bar}/\text{kmol} \cdot \text{K} \times 773 \text{ K}) = 0.0187 \text{ kmol}/\text{m}^3$ , Eq. (14.70) yields a CO molar flux, and hence a CO removal rate, of

$$N_{A,s}'' = -N_A''(0) = \frac{k_1'' C x_{A,L}}{1 + (Lk_1''/D_{AB})}$$

$$N_{A,s}'' = \frac{0.005 \text{ m/s} \times 0.0187 \text{ kmol}/\text{m}^3 \times 0.0012}{1 + (0.01\text{m} \times 0.005 \text{ m/s} / 10^{-4} \text{ m}^2/\text{s})} = 7.48 \times 10^{-8} \text{ kmol}/\text{s} \cdot \text{m}^2 \quad <$$

If the process is diffusion limited,  $Lk_1''/D_{AB} \gg 1$  and

$$N_{A,s}'' = \frac{C D_{AB} x_{A,L}}{L} = \frac{0.0187 \text{ kmol}/\text{m}^3 \times 10^{-4} \text{ m}^2/\text{s} \times 0.0012}{0.01\text{m}} = 2.24 \times 10^{-7} \text{ kmol}/\text{s} \cdot \text{m}^2 \quad <$$

**COMMENTS:** If the process is reaction limited,  $N_{A,s}'' \rightarrow 0$  as  $k_1'' \rightarrow 0$ .

### PROBLEM 14.33

**KNOWN:** Mass flow rate of gas containing palladium (species A), which flows through a tube and deposits into pores of tube wall. Inlet mass concentration of palladium. Mass transfer coefficient between gas and tube surface. Deposition rate is proportional to mass concentration of palladium at tube surface.

**FIND:** (a) Expression for variation of mean species density of palladium with  $x$ . Expression for local deposition rate for tube of diameter  $D$ . (b) Ratio of deposition rates at  $x = L$  and  $x = 0$ .

**SCHEMATIC:**

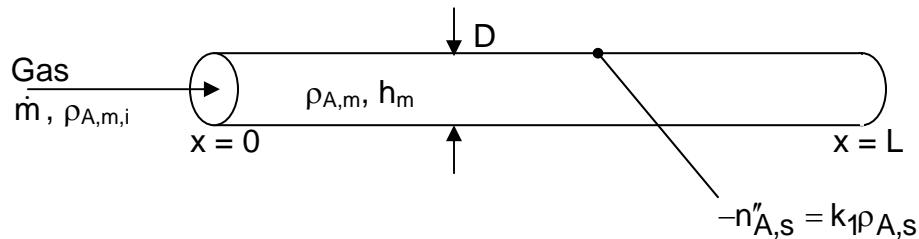

**ASSUMPTIONS:** (1) Steady state, (2) Constant properties, (3) Constant mass flow rate, (4) Negligible leakage of gas through porous walls.

**ANALYSIS:** (a) Section 8.9 develops the variation of mean species density,  $\rho_{A,m}$ , for the case in which the surface species concentration,  $\rho_{A,s}$ , is uniform. Here, however, the surface concentration will vary as the mean species density decreases with  $x$ . Under steady-state conditions, the mass flux of palladium reaching the surface must equal the mass flux of palladium depositing into the pores. Referring to Equation 8.82, where  $n''_{A,s}$  is the mass flux *from* the surface,

$$n''_{A,s} = h_m(\rho_{A,s} - \rho_{A,m}) = -k_1 \rho_{A,s}$$

Solving for the surface concentration yields  $\rho_{A,s} = h_m \rho_{A,m} / (h_m + k_1)$ . Then substituting this into either expression for  $n''_{A,s}$  yields

$$n''_{A,s} = -U_m \rho_{A,m}, \quad U_m^{-1} = 1/h_m + 1/k_1$$

Comparing this result with Equation 8.82, we see that they are analogous if we replace  $h_m$  with  $U_m$  and  $\rho_{A,s}$  with 0. Applying the same analogy to Equation 8.86, the distribution of the mean species density is

$$\frac{\rho_{A,m}(x)}{\rho_{A,m,i}} = \exp\left(-\frac{U_m \rho P}{\dot{m}} x\right) \quad (1) \quad <$$

where  $P$  is the perimeter,  $P = \pi D$ . Note that we could have found this same result by expressing mass species conservation for species A. Noting that the rate at which species A is carried downstream by the flow is  $\dot{m} \rho_{A,m} / \rho$ , and assuming  $\rho$  to be constant, we have

Continued...

**PROBLEM 14.33 (Cont.)**

$$\frac{\dot{m}}{\rho} \frac{d\rho_{A,m}}{dx} = n''_{A,s} P = -U_m P \rho_{A,m}$$

Integrating with respect to  $x$  and applying the inlet condition yields the same result as Equation (1).

The local deposition rate is

$$-n''_{A,s} = U_m \rho_{A,m} = U_m \rho_{A,m,i} \exp\left(-\frac{U_m P}{\dot{m}} x\right) = U_m \rho_{A,m,i} \exp\left(-B \frac{x}{L}\right) \quad (2) \quad <$$

where  $B = U_m P L / \dot{m}$ .

(b) The ratio of deposition rates at  $x = L$  and  $x = 0$  is

$$\text{ratio of deposition rates} = \exp(-B) \quad <$$

**COMMENT:** From Eq. (2), the deposition rate decreases exponentially with distance  $x$ . Therefore, as the tube length increases, the deposit thickness at the outlet end will become thinner, and the variation in deposit thickness between the inlet and outlet will increase.

### PROBLEM 14.34

**KNOWN:** Radius of a spherical organism and molar concentration of oxygen at surface. Diffusion and reaction rate coefficients.

**FIND:** (a) Radial distribution of O<sub>2</sub> concentration, (b) Rate of O<sub>2</sub> consumption, (c) Molar concentration at r = 0.

**SCHEMATIC:**

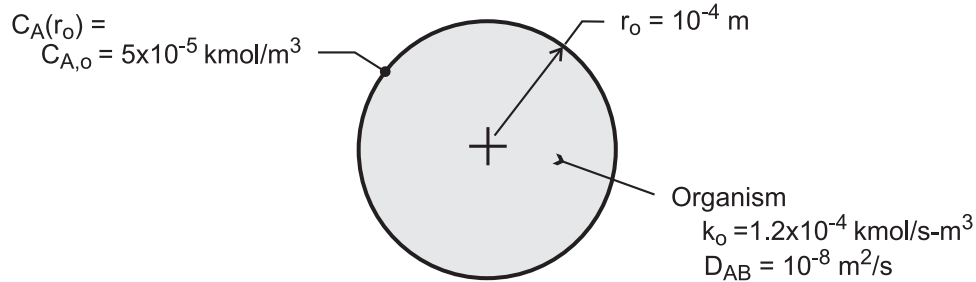

**ASSUMPTIONS:** (1) Steady-state, one-dimensional diffusion, (2) Stationary medium, (3) Uniform total molar concentration, (4) Constant properties ( $k_0$ ,  $D_{AB}$ ).

**ANALYSIS:** (a) For the prescribed conditions and assumptions, Eq. (14.50) reduces to

$$\frac{D_{AB}}{r^2} \frac{d}{dr} \left( r^2 \frac{dC_A}{dr} \right) - k_0 = 0$$

$$r^2 \frac{dC_A}{dr} = \frac{k_0 r^3}{3D_{AB}} + C_1$$

$$C_A = \frac{k_0 r^2}{6D_{AB}} - \frac{C_1}{r} + C_2$$

With the requirement that  $C_A(r)$  remain finite at  $r = 0$ ,  $C_1 = 0$ . With  $C_A(r_o) = C_{A,o}$

$$C_2 = C_{A,o} - \frac{k_0 r_o^2}{6D_{AB}}$$

$$C_A = C_{A,o} - (k_0 / 6D_{AB}) (r_o^2 - r^2) \quad <$$

Because  $C_A$  cannot be less than zero at any location within the organism, the right-hand side of the foregoing equation must always exceed zero, thereby placing limits on the value of  $C_{A,o}$ . The smallest possible value of  $C_{A,o}$  is determined from the requirement that  $C_A(0) \geq 0$ , in which case

$$C_{A,o} \geq (k_0 r_o^2 / 6D_{AB}) \quad <$$

(b) Since oxygen consumption occurs at a uniform volumetric rate of  $k_0$ , the total respiration rate is  $\dot{R} = \forall k_0$ , or

$$\dot{R} = (4/3) \pi r_o^3 k_0 \quad <$$

Continued ...

### PROBLEM 14.34 (Cont.)

(c) With  $r = 0$ ,

$$C_A(0) = C_{A,o} - k_0 r_0^2 / 6D_{AB}$$

$$C_A(0) = 5 \times 10^{-5} \text{ kmol/m}^3 - 1.2 \times 10^{-4} \text{ kmol/s} \cdot \text{m}^3 \left(10^{-4} \text{ m}\right)^2 / 6 \times 10^{-8} \text{ m}^2/\text{s}$$

$$C_A(0) = 3 \times 10^{-5} \text{ kmol/m}^3 \quad <$$

**COMMENTS:** (1) The minimum value of  $C_{A,o}$  for which a physically realistic solution is possible is  $C_{A,o} = k_0 r_0^2 / 6D_{AB} = 2 \times 10^{-5} \text{ kmol/m}^3$ .

(2) The total respiration rate may also be obtained by applying Fick's law at  $r = r_0$ , in which case  $\dot{R} = -N_A(r_0) = +D_{AB} \left(4\pi r_0^2\right) dC_A/dr|_{r=r_0} = D_{AB} \left(4\pi r_0^2\right) (k_0 / 6D_{AB}) 2r_0 = (4/3)\pi r_0^3 k_0$ .  
The result agrees with that of part (b).

### PROBLEM 14.35

**KNOWN:** Radius of a spherical organism and molar concentration of oxygen at its surface. Diffusion and reaction rate coefficients.

**FIND:** (a) Radial distribution of O<sub>2</sub> concentration, (b) Expression for rate of O<sub>2</sub> consumption, (c) Molar concentration at r = 0 and rate of oxygen consumption for prescribed conditions.

**SCHEMATIC:**

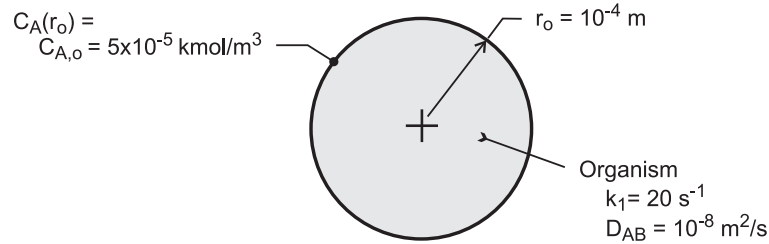

**ASSUMPTIONS:** (1) Steady-state, one-dimensional diffusion, (2) Stationary medium, (3) Uniform total molar concentration, (4) Constant properties ( $k_1$ ,  $D_{AB}$ ).

**ANALYSIS:** (a) For the prescribed conditions and assumptions, Eq. (14.50) reduces to

$$\frac{1}{r^2} \frac{d}{dr} \left( D_{AB} r^2 \frac{dC_A}{dr} \right) - k_1 C_A = 0$$

With  $y \equiv r C_A$ ,  $dC_A/dr = (1/r) dy/dr - y/r^2$  and

$$\frac{1}{r^2} \frac{d}{dr} \left( D_{AB} r^2 \frac{dC_A}{dr} \right) = \frac{D_{AB}}{r^2} \frac{d}{dr} \left( r \frac{dy}{dr} - y \right) = \frac{D_{AB}}{r^2} \left( r \frac{d^2y}{dr^2} \right)$$

The species equation is then

$$\frac{d^2y}{dr^2} - \frac{k_1}{D_{AB}} y = 0$$

The general solution is of the form

$$y = C_1 \sinh(k_1/D_{AB})^{1/2} r + C_2 \cosh(k_1/D_{AB})^{1/2} r$$

or

$$C_A = \frac{C_1}{r} \sinh(k_1/D_{AB})^{1/2} r + \frac{C_2}{r} \cosh(k_1/D_{AB})^{1/2} r$$

Because  $C_A$  must remain finite at  $r = 0$ ,  $C_2 = 0$ . Hence, with  $C_A(r_o) = C_{A,o}$ ,

$$C_1 = \frac{C_{A,o} r_o}{\sinh(k_1/D_{AB})^{1/2} r_o}$$

and

Continued ...

**PROBLEM 14.35 (Cont.)**

$$C_A = C_{A,o} \left( \frac{r_0}{r} \right) \frac{\sinh(k_1/D_{AB})^{1/2} r}{\sinh(k_1/D_{AB})^{1/2} r_0} \quad <$$

(b) The total O<sub>2</sub> consumption rate corresponds to the rate of diffusion at the surface of the organism.

$$\dot{R} = -N_A(r_0) = +D_{AB} \left( 4\pi r_0^2 \right) dC_A / dr \Big|_{r_0}$$

$$\dot{R} = 4\pi r_0^2 D_{AB} C_{A,o} r_0 \left[ -\frac{1}{r_0^2} + \frac{1}{r_0} (k_1/D_{AB})^{1/2} \cot(k_1/D_{AB})^{1/2} r_0 \right]$$

$$\dot{R} = 4\pi r_0 D_{AB} C_{A,o} (\alpha \coth \alpha - 1) \quad <$$

where  $\alpha \equiv \left( k_1 r_0^2 / D_{AB} \right)^{1/2}$ .

(c) For the prescribed conditions,  $(k_1/D_{AB})^{1/2} = (20 \text{ s}^{-1} \div 10^{-8} \text{ m}^2/\text{s})^{1/2} = 44,720 \text{ m}^{-1}$  and  $\alpha = 4.472$ .

$$C_A = \frac{5 \times 10^{-5} \text{ kmol/m}^3 \times 10^{-4} \text{ m}}{\sinh(4.472)} \times \frac{\sinh(k_1/D_{AB})^{1/2} r}{r} = 1.136 \times 10^{-10} \frac{\text{kmol}}{\text{m}^3} \times \frac{\sinh(k_1/D_{AB})^{1/2} r}{r}$$

In the limit of  $r \rightarrow 0$ , the foregoing expression yields

$$C_A(r \rightarrow 0) = 5.11 \times 10^{-6} \text{ kmol/m}^3 \quad <$$

$$\begin{aligned} \dot{R} &= 4\pi \times 10^{-4} \text{ m} \times 10^{-8} \text{ m}^2/\text{s} \times 5 \times 10^{-5} \text{ kmol/m}^3 (4.472 \coth 4.472 - 1) \\ &= 2.18 \times 10^{-15} \text{ kmol/s} \end{aligned}$$

**COMMENTS:** The total respiration rate may also be obtained by integrating the volumetric rate of consumption over the volume of the organism. That is,  $\dot{R} = -\int \dot{N}_A dV = \int_0^{r_0} k_1 C_A(r) 4\pi r^2 dr$ .



### PROBLEM 14.36

**KNOWN:** Combustion at constant temperature and pressure of a hydrogen-oxygen mixture adjacent to a metal wall according to the reaction  $2\text{H}_2 + \text{O}_2 \rightarrow 2\text{H}_2\text{O}$ . Molar concentrations of hydrogen, oxygen, and water vapor are  $0.10$ ,  $0.10$  and  $0.20 \text{ kmol/m}^3$ , respectively. Generation rate of water vapor is  $0.96 \times 10^{-2} \text{ kmol/m}^3 \cdot \text{s}$ .

**FIND:** (a) Expression for  $C_{\text{H}_2}$  as function of distance from wall, plot qualitatively, (b)  $C_{\text{H}_2}$  at the wall, (c) Sketch also curves for  $C_{\text{O}_2}(x)$  and  $C_{\text{H}_2\text{O}}(x)$ , and (d) Molar flux of water at  $x = 10 \text{ mm}$ .

**SCHEMATIC:**

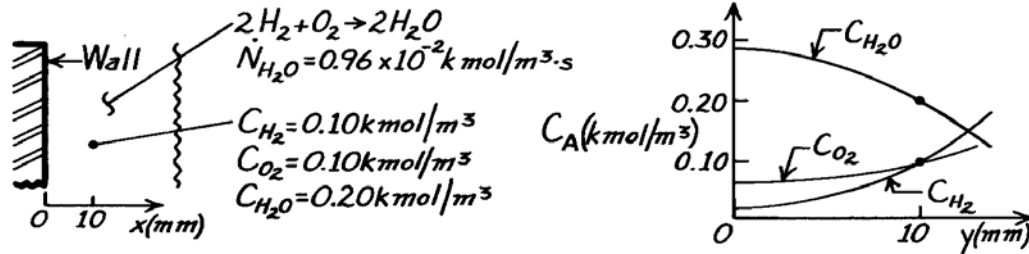

**ASSUMPTIONS:** (1) Steady-state conditions, (2) One-dimensional diffusion, (3) Stationary medium, (4) Constant properties including pressure and temperature.

**PROPERTIES:** Species binary diffusion coefficient (given, for  $\text{H}_2$ ,  $\text{O}_2$  and  $\text{H}_2\text{O}$ ):  $D_{\text{AB}} = 0.6 \times 10^{-5} \text{ m}^2/\text{s}$ .

**ANALYSIS:** (a) The species conservation equation, Eq. 14.48b, and its general solution are

$$\frac{d^2 C_A}{dx^2} + \frac{\dot{N}_A}{D_{\text{AB}}} = 0 \quad C_A(x) = -\frac{\dot{N}_A}{2D_{\text{AB}}} x^2 + C_1 x + C_2. \quad (1,2)$$

The boundary condition at the wall must be  $dC_A(0)/dx = 0$ , such that  $C_1 = 0$ . For the species hydrogen, evaluate  $C_2$  from knowledge of  $C_{\text{H}_2}(10 \text{ mm}) = 0.10 \text{ kmol/m}^3$  and  $\dot{N}_{\text{H}_2} = -\dot{N}_{\text{H}_2\text{O}}$ , according to the chemical reaction. Hence,

$$0.10 \text{ kmol/m}^3 = -\frac{(-0.96 \times 10^{-2} \text{ kmol/m}^3 \cdot \text{s})}{2 \times 0.6 \times 10^{-5} \text{ m}^2/\text{s}} (0.010 \text{ m})^2 + 0 + C_2$$

$$C_2 = 0.02 \text{ kmol/m}^3.$$

Hence, the hydrogen species concentration distribution is

$$C_{\text{H}_2}(x) = -\frac{\dot{N}_{\text{H}_2}}{2D_{\text{AB}}} x^2 + 0.02 = 800x^2 + 0.02 \quad <$$

which is parabolic with zero slope at the wall; see sketch above.

(b) The value of  $C_{\text{H}_2}$  at the wall is,

$$C_{\text{H}_2}(0) = (0 + 0.02) \text{ kmol/m}^3 = 0.02 \text{ kmol/m}^3. \quad <$$

Continued ...

**PROBLEM 14.36 (Cont.)**

(c) The concentration distribution for water vapor species will be of the same form,

$$C_{\text{H}_2\text{O}}(x) = -\frac{\dot{N}_{\text{H}_2\text{O}}}{2D_{\text{AB}}}x^2 + C_1x + C_2 \quad (3)$$

With  $C_1 = 0$  for the wall condition, find  $C_2$  from  $C_{\text{H}_2\text{O}}(10 \text{ mm})$ ,

$$0.20 \text{ kmol/m}^3 = -\frac{(0.96 \times 10^{-2} \text{ kmol/m}^3)}{2 \times 0.6 \times 10^{-5} \text{ m}^2/\text{s}}(0.010 \text{ m})^2 + C_2 \quad C_2 = 0.28 \text{ kmol/m}^3.$$

Hence,  $C_{\text{H}_2\text{O}}$  at the wall is,

$$C_{\text{H}_2\text{O}}(0) = 0 + 0 + C_2 = 0.28 \text{ kmol/m}^3$$

and its distribution appears as above. Recognizing that  $\dot{N}_{\text{O}_2} = -0.5\dot{N}_{\text{H}_2\text{O}}$ , by the same analysis, find

$$C_{\text{O}_2}(0) = 0.06 \text{ kmol/m}^3$$

and its shape, also parabolic with zero slope at the wall is shown above.

(d) The molar flux of water vapor at  $x = 10 \text{ mm}$  is given by Fick's law

$$N''_{\text{H}_2\text{O},x} = -D_{\text{AB}} \frac{dC_{\text{H}_2\text{O}}}{dx}$$

and using the concentration distribution of Eq. (3), find

$$N''_{\text{H}_2\text{O},x} = -D_{\text{AB}} \frac{d}{dx} \left( -\frac{\dot{N}_{\text{H}_2\text{O}}}{2D_{\text{AB}}}x^2 \right) = +\dot{N}_{\text{H}_2\text{O}}x$$

and evaluation at the location  $x = 10 \text{ mm}$ , the species flux is

$$N''_{\text{H}_2\text{O},x}(10 \text{ mm}) = +(0.96 \times 10^{-2} \text{ kmol/m}^3 \cdot \text{s}) \times 0.010 \text{ m} = 9.60 \times 10^{-5} \text{ kmol/m}^2 \cdot \text{s} \quad <$$

**COMMENTS:** Note that the generation rate of water vapor is a positive quantity. Whereas for  $\text{H}_2$  and  $\text{O}_2$ , species are consumed and hence  $\dot{N}_{\text{H}_2}$  and  $\dot{N}_{\text{O}_2}$  are negative. According to the chemical reaction one mole of  $\text{H}_2$  and 0.5 mole of  $\text{O}_2$  are consumed to generate one mole of  $\text{H}_2\text{O}$ . Therefore,  $\dot{N}_{\text{H}_2} = -\dot{N}_{\text{H}_2\text{O}}$  and  $\dot{N}_{\text{O}_2} = -0.5 \dot{N}_{\text{H}_2\text{O}}$ .

### PROBLEM 14.37

**KNOWN:** Molar concentrations of oxygen at inner and outer surfaces of lung tissue. Volumetric rate of oxygen consumption within the tissue.

**FIND:** (a) Variation of oxygen molar concentration with position in the tissue, (b) Rate of oxygen transfer to the blood per unit tissue surface area.

**SCHEMATIC:**

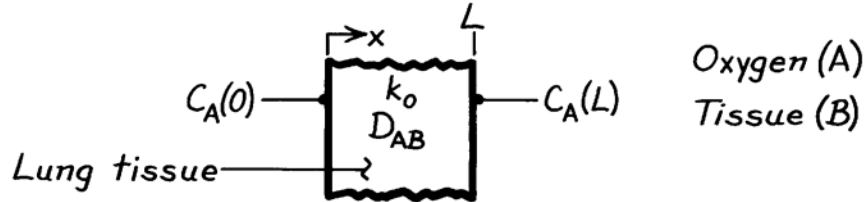

**ASSUMPTIONS:** (1) Steady-state conditions, (2) One-dimensional species transfer by diffusion through a plane wall, (3) Homogeneous, stationary medium with uniform total molar concentration and constant diffusion coefficient.

**ANALYSIS:** (a) From Eq. 14.71 the appropriate form of the species diffusion equation is

$$D_{AB} \frac{d^2 C_A}{dx^2} - k_o = 0.$$

Integrating,

$$dC_A / dx = (k_o / D_{AB})x + C_1 \quad C_A = \frac{k_o}{2D_{AB}}x^2 + C_1x + C_2.$$

With  $C_A = C_A(0)$  at  $x = 0$  and  $C_A = C_A(L)$  at  $x = L$ ,

$$C_2 = C_A(0) \quad C_1 = \frac{C_A(L) - C_A(0)}{L} - \frac{k_o L}{2D_{AB}}.$$

Hence

$$C_A(x) = \frac{k_o}{2D_{AB}}x(x-L) + [C_A(L) - C_A(0)]\frac{x}{L} + C_A(0). \quad <$$

(b) The oxygen assimilation rate per unit area is

$$N''_{A,x}(L) = -D_{AB} \left( \frac{dC_A}{dx} \right)_{x=L}$$

$$N''_{A,x}(L) = -D_{AB} \left( \frac{k_o L}{D_{AB}} - \frac{k_o L}{2D_{AB}} \right) - \frac{D_{AB}}{L} [C_A(L) - C_A(0)]$$

$$N''_{A,x} = -\frac{k_o L}{2} + \frac{D_{AB}}{L} [C_A(0) - C_A(L)]. \quad <$$

**COMMENTS:** The above model provides a highly approximate and simplified treatment of a complicated problem. The lung tissue is actually heterogeneous and conditions are transient.

### PROBLEM 14.38

**KNOWN:** Ground level flux of  $\text{NO}_2$  in a stagnant urban atmosphere.

**FIND:** (a) Vertical distribution of  $\text{NO}_2$  molar concentration, (b) Critical ground level flux of  $\text{NO}_2$ ,  $N''_{A,0,\text{crit}}$ .

**SCHEMATIC:**

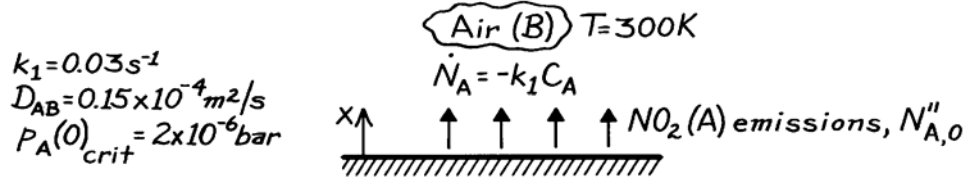

**ASSUMPTIONS:** (1) Steady-state conditions, (2) One-dimensional diffusion in a stationary medium, (3) Total molar concentration  $C$  is uniform, (4) Perfect gas behavior.

**ANALYSIS:** (a) For the prescribed conditions the molar concentration of  $\text{NO}_2$  is given by Eq. 14.73, subject to the following boundary conditions.

$$C_A(\infty) = 0, \quad \left. \frac{dC_A}{dx} \right|_{x=0} = -\frac{N''_{A,0}}{D_{AB}}.$$

From the first condition,  $C_1 = 0$ . From the second condition,

$$-mC_2 = -N''_{A,0}/D_{AB}.$$

Hence

$$C_A(x) = \frac{N''_{A,0}}{mD_{AB}} e^{-mx} \quad <$$

where  $m = (k_1/D_{AB})^{1/2}$ .

(b) At ground level,  $C_A(0) = \frac{N''_{A,0}}{mD_{AB}}$ . Hence, from the perfect gas law,

$$P_A(0) = C_A(0) \mathcal{R}T = \frac{\mathcal{R}T N''_{A,0}}{mD_{AB}}.$$

Hence, with  $m = (0.03/0.15 \times 10^{-4})^{1/2} \text{ m}^{-1} = 44.7 \text{ m}^{-1}$ .

$$N''_{A,0,\text{crit}} = \frac{mD_{AB}P_A(0)_{\text{crit}}}{\mathcal{R}T} = \frac{44.7 \text{ m}^{-1} \times 0.15 \times 10^{-4} \text{ m}^2/\text{s} \times 2 \times 10^{-6} \text{ bar}}{8.314 \times 10^{-2} \text{ m}^3 \cdot \text{bar}/\text{kmol} \cdot \text{K} \times 300 \text{ K}}$$

$$N''_{A,0,\text{crit}} = 5.38 \times 10^{-11} \text{ kmol}/\text{s} \cdot \text{m}^2. \quad <$$

**COMMENTS:** Because the dispersion of pollutants in the atmosphere is governed strongly by convection effects, the above model should be viewed as a first approximation which describes a worst case condition.

### PROBLEM 14.39

**KNOWN:** Ground level flux of NO<sub>2</sub> in a stagnant urban atmosphere.

**FIND:** (a) Governing differential equation and boundary conditions for the molar concentration of NO<sub>2</sub>, (b) Concentration of NO<sub>2</sub> at ground level three hours after the beginning of emissions.

**SCHEMATIC:**

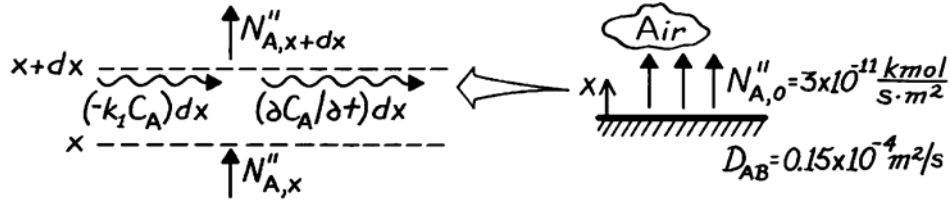

**ASSUMPTIONS:** (1) One-dimensional diffusion in a stationary medium, (2) Uniform total molar concentration, (3) Constant properties.

**ANALYSIS:** (a) Applying the species conservation requirement, Eq. 14.43, on a molar basis to a unit area of the control volume,

$$N''_{A,x} - (k_1 C_A) dx - N''_{A,x+dx} = \frac{\partial C_A}{\partial t} dx.$$

With  $N''_{A,x+dx} = N''_{A,x} + (\partial N''_{A,x} / \partial x) dx$  and  $N''_{A,x} = -D_{AB} (\partial C_A / \partial x)$ , it follows that

$$D_{AB} \frac{\partial^2 C_A}{\partial x^2} - k_1 C_A = \frac{\partial C_A}{\partial t}. \quad <$$

Initial Condition:  $C_A(x, 0) = 0. \quad <$

Boundary Conditions:  $-D_{AB} \left. \frac{\partial C_A}{\partial x} \right|_{x=0} = N''_{A,0}, \quad C_A(\infty, t) = 0. \quad <$

(b) The present problem is analogous to Case (2) of Fig. 5.7 for heat conduction in a semi-infinite medium. Hence by analogy to Eq. 5.62, with  $k \leftrightarrow D_{AB}$  and  $\alpha \leftrightarrow D_{AB}$ ,

$$C_A(x, t) = 2N''_{A,0} \left( \frac{t}{\pi D_{AB}} \right)^{1/2} \exp\left(-\frac{x^2}{4D_{AB}t}\right) - \frac{N''_{A,0} x}{D_{AB}} \operatorname{erfc}\left(\frac{x}{2(D_{AB}t)^{1/2}}\right)$$

At ground level ( $x = 0$ ) and 3h,

$$C_A(0, 3h) = 2N''_{A,0} \left( \frac{t}{\pi D_{AB}} \right)^{1/2}$$

$$C_A(0, 3h) = 2 \left( 3 \times 10^{-11} \text{ kmol/s} \cdot \text{m}^2 \right) \left( 10,800 \text{ s} / \pi \times 0.15 \times 10^{-4} \text{ m}^2 / \text{s} \right)^{1/2} = 9.08 \times 10^{-7} \text{ kmol/m}^3. \quad <$$

**COMMENTS:** The concentration decays rapidly to zero with increasing  $x$ , and at  $x = 100$  m it is, for all practical purposes, equal to zero.

### PROBLEM 14.40

**KNOWN:** Initial concentration of hydrogen in a sheet of prescribed thickness. Surface concentrations for time  $t > 0$ .

**FIND:** Time required for density of hydrogen to reach prescribed value at midplane of sheet.

**SCHEMATIC:**

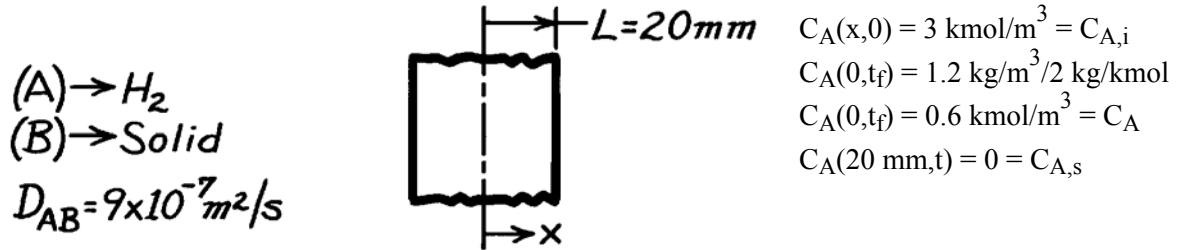

**ASSUMPTIONS:** (1) One-dimensional diffusion in  $x$ , (2) Constant  $D_{AB}$ , (3) No internal chemical reactions, (4) Uniform total molar concentration, (5) Stationary medium.

**ANALYSIS:** The mass transfer Biot number is  $Bi_m = h_m L / D_{AB} \rightarrow \infty$ . Hence,  $Bi_m^{-1} = 0$ . By analogy to Equation 5.44, the approximate solution, it follows that

$$\gamma_o^* \approx C_1 \exp\left(-\zeta_1^2 Fo_m\right) = \frac{C_A - C_{A,s}}{C_{A,i} - C_{A,s}} = \frac{0.6 - 0.0}{3.0 - 0.0} = 0.2$$

Using values of  $\zeta_1 = 1.57$  and  $C_1 = 1.27$  from Table 5.1, it follows that

$$1.27 \exp\left[-(1.57)^2 Fo_m\right] = 0.2$$

from which

$$Fo_m = 0.75$$

Hence,  $t_f = 0.75(0.02\text{m})^2 / 9 \times 10^{-7} \text{ m}^2/\text{s} = 333 \text{ s}$

<

**COMMENT:**  $Fo_m > 0.2$ . Hence, the approximate, one-term solution is valid.

### PROBLEM 14.41

**KNOWN:** Radius and temperature of air bubble in water.

**FIND:** Time to reach 99% of saturated vapor concentration at center.

**SCHEMATIC:**

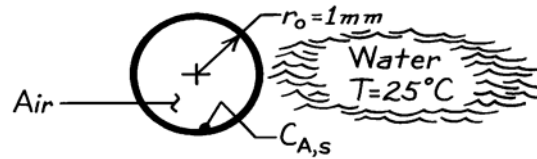

**ASSUMPTIONS:** (1) One-dimensional radial diffusion of vapor in air, (2) Constant properties, (3) Air is initially dry, (4) Stationary medium.

**PROPERTIES:** Table A-8, Water vapor-air (300 K):  $D_{AB} = 0.26 \times 10^{-4} \text{ m}^2/\text{s}$ .

**ANALYSIS:** If the one-term approximation to the infinite series solution (Eq. 5.53),

$$\theta_0^* = C_1 \exp(-\zeta_1^2 \text{Fo})$$

is used, it follows that,

$$\gamma_o^* \approx C_1 \exp(-\zeta_1^2 \text{Fo}_m) = \frac{C_A - C_{A,s}}{C_{A,i} - C_{A,s}} = \frac{0.99 - 1}{0.0 - 1} = 0.01.$$

Using values of  $C_1 = 2.0$  and  $\zeta_1 = 3.1415$  for  $\text{Bi}_m \rightarrow \infty$ , it follows that

$$0.01 = 2.0 \exp\left[-(3.1415)^2 \text{Fo}_m\right] \quad \text{or} \quad \text{Fo}_m = 0.54$$

Hence,  $t = \text{Fo}_m D^2 / D_{AB} = 0.54(0.001\text{m})^2 / 0.26 \times 10^{-4} \text{ m}^2/\text{s} = 0.02 \text{ s}$

<

**COMMENT:** Since  $\text{Fo} > 0.2$ , the approximate solution is valid.

## PROBLEM 14.42

**KNOWN:** Radius and temperature of air bubble.

**FIND:** (a) Time to reach 95% of the maximum average water vapor concentration, (b) Time to reach 50% of the maximum average water vapor concentration.

**SCHEMATIC:**

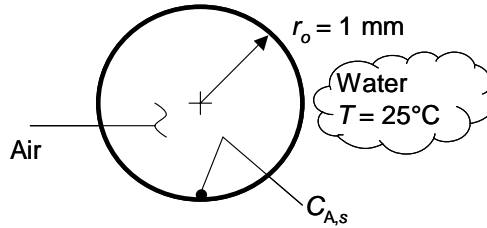

**ASSUMPTIONS:** (1) One-dimensional radial diffusion of vapor in air, (2) Constant properties, (3) Air is initially dry, (4) Stationary medium.

**PROPERTIES:** Table A.8, Water vapor-air (300 K):  $D_{AB} = 0.26 \times 10^{-4} \text{ m}^2/\text{s}$ .

**ANALYSIS:** (a) We may employ the one-term approximation to the infinite series solution (Eq. 5.55)

$$\frac{Q}{Q_o} = 1 - \frac{3\theta_o^*}{\zeta_1^3} [\sin(\zeta_1) - \zeta_1 \cos(\zeta_1)] \quad ; \quad \theta_o^* = C_1 \exp(-\zeta_1^2 Fo)$$

By analogy, the preceding equations may be written as

$$\frac{\bar{C}_A}{\bar{C}_{A,\max}} = 1 - \frac{3\gamma_o^*}{\zeta_1^3} [\sin(\zeta_1) - \zeta_1 \cos(\zeta_1)] \quad ; \quad \gamma_o^* = \frac{C_A - C_{A,s}}{C_{A,i} - C_{A,s}} = C_1 \exp(-\zeta_1^2 Fo_m)$$

Using values of  $C_1 = 2.000$  and  $\zeta_1 = 3.1415$  from Table 5.1 for  $Bi_m \rightarrow \infty$ , it follows that

$$\frac{\bar{C}_A}{\bar{C}_{A,\max}} = 0.95 = 1 - \frac{3\gamma_o^*}{3.1415^3} [\sin(3.1415) - 3.1415 \cos(3.1415)] \quad ;$$

$$\gamma_o^* = \frac{C_A - C_{A,s}}{C_{A,i} - C_{A,s}} = 2.0 \exp(-3.1415^2 Fo_m)$$

Solving the two equations yields  $\gamma_o^* = 0.1645$ ,  $Fo_m = 0.2531$ . Since  $Fo_m > 0.2$ , the approximate solution is valid. Hence,

$$t = Fo_m r_o^2 / D_{AB} = 0.2531(0.001\text{m})^2 / 0.26 \times 10^{-4} \text{ m}^2 / \text{s} = 9.7 \times 10^{-3} \text{ s} = 9.7 \text{ ms} \quad <$$

(b) The time associated with an average water vapor concentration of 50% is expected to be significantly shorter than in part (a). Hence,  $Fo_m$  may be less than 0.2 and the one-term approximation to the exact solution may not be valid. Therefore, we employ the approximate solution of Section 5.8 and apply the analogy between heat and mass transfer.

Continued...



### PROBLEM 14.42 (Cont.)

From Table 5.2a for  $Fo < 0.2$ ,

$$q_s^* = \frac{q_s'' r_o}{k(T_s - T_i)} = \frac{1}{\sqrt{\pi Fo}} - 1 \quad ; \quad Fo = \frac{\alpha t}{r_o^2}$$

Substituting the expression for  $Fo$  into the first equation yields

$$q_s'' = \frac{k(T_s - T_i)}{r_o} \left[ \frac{r_o}{\sqrt{\pi \alpha}} t^{-1/2} - 1 \right]$$

We desire an expression for  $Q/Q_o$ . Hence,

$$\frac{Q}{Q_o} = \frac{4\pi r_o^2 \int_{t=0}^t q_s'' dt}{(4/3)\pi r_o^3 \rho c (T_s - T_i)} = \frac{3\alpha}{r_o^2} \int_{t=0}^t \left( \frac{r_o}{\sqrt{\pi \alpha}} t^{-1/2} - 1 \right) dt$$

or

$$\begin{aligned} \frac{Q}{Q_o} &= \frac{3\alpha}{r_o^2} \left[ \frac{2r_o}{\sqrt{\pi \alpha}} t^{1/2} - t \right] \\ &= 3 \left[ \frac{2}{\sqrt{\pi}} \sqrt{Fo} - Fo \right] \end{aligned}$$

Applying the analogy between heat and mass transfer,

$$\frac{\bar{C}_A}{\bar{C}_{A,\max}} = 0.50 = 3 \left[ \frac{2}{\sqrt{\pi}} \sqrt{Fo_m} - Fo_m \right]$$

from which  $Fo_m = 0.0305$ . Hence,

$$t = Fo_m r_o^2 / D_{AB} = 0.0305 (0.001 \text{ m})^2 / 0.26 \times 10^{-4} \text{ m}^2 / \text{s} = 1.17 \times 10^{-3} \text{ s} = 1.17 \text{ ms} \quad <$$

**COMMENTS:** (1) Use of the approximate solution of Section 5.8 is not valid for part (a) since its use yields  $Fo_m = 0.366$ , which does not satisfy the criterion  $Fo_m < 0.2$ . (2) Use of the one-term approximation to the exact solution for part (b) yields a mass transfer Fourier number of  $Fo_m = 0.0198$ , which does not satisfy the criterion  $Fo_m > 0.2$ .

### PROBLEM 14.43

**KNOWN:** Initial carbon content and prescribed surface content for heated steel.

**FIND:** Time required for carbon mole fraction to reach 0.01 at a distance of 1 mm from the surface.

**SCHEMATIC:**

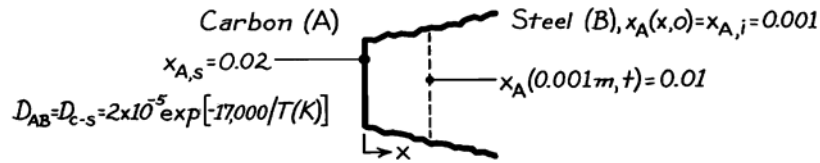

**ASSUMPTIONS:** (1) Steel may be approximated as a semi-infinite medium, (2) One-dimensional diffusion in  $x$ , (3) Isothermal conditions, (4) No internal chemical reactions, (5) Uniform total molar concentration, (6) Stationary medium.

**ANALYSIS:** Conditions within the steel are governed by the species diffusion equation of the form

$$\frac{\partial^2 C_A}{\partial x^2} = \frac{1}{D_{AB}} \frac{\partial C_A}{\partial t}$$

or, in molar form,

$$\frac{\partial^2 x_A}{\partial x^2} = \frac{1}{D_{AB}} \frac{\partial x_A}{\partial t}$$

The initial and boundary conditions are of the form

$$x_A(x, 0) = 0.001$$

$$x_A(0, t) = x_{A,s} = 0.02 \quad x_A(\infty, t) = 0.001.$$

The problem is analogous to that of heat transfer in a semi-infinite medium with constant surface temperature, and by analogy to Eq. 5.60, the solution is

$$\frac{x_A(x, t) - x_{A,s}}{x_{A,i} - x_{A,s}} = \operatorname{erf}\left(\frac{x}{2(D_{AB}t)^{1/2}}\right)$$

where

$$D_{AB} = 2 \times 10^{-5} \exp[-17,000/1273] = 3.17 \times 10^{-11} \text{ m}^2/\text{s}.$$

Hence

$$\frac{0.01 - 0.02}{0.001 - 0.02} = 0.526 = \operatorname{erf}\left(\frac{0.001 \text{ m}}{2(3.17 \times 10^{-11} t)^{1/2}}\right)$$

where  $\operatorname{erf} w = 0.526 \rightarrow w \approx 0.51$ ,

$$0.51 = 0.001/2(3.17 \times 10^{-11} t)^{1/2} \quad \text{or} \quad t = 30,321 \text{ s} = 8.42 \text{ h. } <$$

## PROBLEM 14.44

**KNOWN:** Thick plate of pure iron at 1000°C subjected to a carburizing process with sudden exposure to a carbon concentration  $C_{C,s}$  at the surface.

**FIND:** (a) Consider the heat transfer analog to the carburization process; sketch the mass and heat transfer systems; explain correspondence between variables; provide analytical solutions to the mass and heat transfer situation; (b) Determine the carbon concentration ratio,  $C_C(x, t)/C_{C,s}$ , at a depth of 1 mm after 1 hour of carburization; and (c) From the analogy, show that the time dependence of the mass flux of carbon into the plate can be expressed as  $n_C'' = \rho_{C,s} (D_{C-Fe} / \pi t)^{1/2}$ ; also, obtain an expression for the mass of carbon per unit area entering the iron plate over the time period  $t$ .

**SCHEMATIC:**

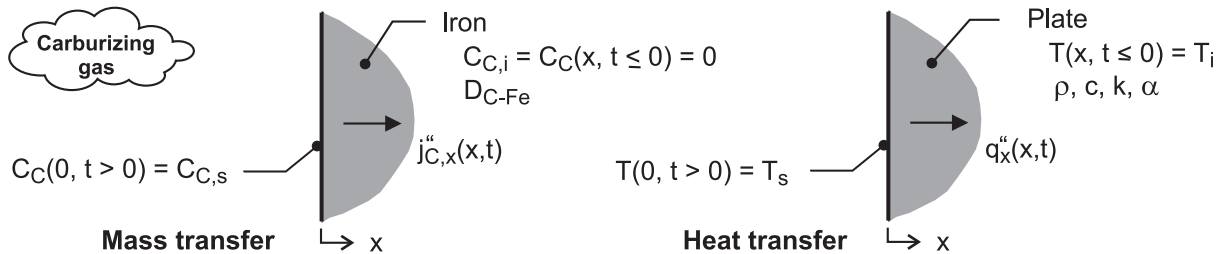

**ASSUMPTIONS:** (1) One-dimensional transient diffusion, (2) Thick plate approximates a semi-infinite medium for the transient mass and heat transfer processes, and (3) Constant properties, (4) Stationary medium.

**ANALYSIS:** (a) The analogy between the carburizing mass transfer process in the plate and the heat transfer process is illustrated in the schematic above. The basis for the mass - heat transfer analogy stems from the similarity of the conservation of species and energy equations (Eqs. 14.77 and 5.29, respectively), the general solution to the equations, and their initial and boundary conditions. For both processes, the plate is a semi-infinite medium with initial distributions,  $C_C(x, t \leq 0) = C_{C,i} = 0$  and  $T(x, t \leq 0) = T_i$ , suddenly subjected to a surface potential,  $C_C(0, t > 0) = C_{C,s}$  and  $T(0, t > 0) = T_s$ . The heat transfer situation corresponds to Case 1, Figure 5.7, from which the following relations were obtained.

**Heat transfer**  
Distributions

$$\frac{T(x, t) - T_s}{T_i - T_s} = \operatorname{erf}\left(\frac{x}{2\sqrt{\alpha t}}\right)$$

**Mass transfer**

$$\frac{C_c(x, t) - C_{c,s}}{0 - C_{c,s}} = \operatorname{erf}\left(\frac{x}{2\sqrt{D_{C-Fe}t}}\right)$$

or

$$\frac{C_c(x, t)}{C_{c,s}} = \operatorname{erfc}\left(\frac{x}{2\sqrt{D_{C-Fe}t}}\right)$$

Fluxes

$$q_s''(t) = \frac{k(T_s - T_i)}{\sqrt{\pi \alpha t}}$$

$$n_{C,s}''(t) = \frac{D_{C-Fe}(\rho_{C,s})}{\sqrt{\pi D_{C-Fe}t}}$$

Continued ...

### PROBLEM 14.44 (Cont.)

(b) Using the concentration distribution expression above, with  $L = 1 \text{ mm}$ ,  $t = 1 \text{ h}$  and  $D_{\text{C-Fe}} = 3 \times 10^{-11} \text{ m}^2/\text{s}$ , find the concentration ratio,

$$\frac{C_C(1 \text{ mm}, 1 \text{ h})}{C_{\text{C},s}} = \text{erfc} \left( \frac{0.001 \text{ m}}{2(3 \times 10^{-11} \text{ m}^2/\text{s} \times 3600 \text{ s})^{1/2}} \right) = 0.0314 \quad <$$

(c) From the species flux expression above, the mass flux of carbon can be written as

$$\dot{n}_{\text{C},s} = \rho_{\text{C},s} (D_{\text{C-Fe}}/\pi t)^{1/2} \quad <$$

The mass per unit area entering the plate over the time period follows from the integration of the rate expression

$$m_{\text{C}}(t) = \int_0^t \dot{n}_{\text{C},s} dt = \rho_{\text{C},s} (D_{\text{C-Fe}}/\pi)^{1/2} \int_0^t t^{-1/2} dt = 2 \rho_{\text{C},s} (D_{\text{C-Fe}} t/\pi)^{1/2} \quad <$$

## PROBLEM 14.45

**KNOWN:** Radius of pharmaceutical product, density of the active ingredient, partition coefficient, and binary diffusion coefficient of the active ingredient in the gastrointestinal tract.

**FIND:** (a) Dosage delivered over 5 hours from a  $D = 6$  mm diameter tablet, (b) Dosage delivered over 5 hours from  $N = 200$  small, spherical tablets of the same mass.

**SCHEMATIC:**

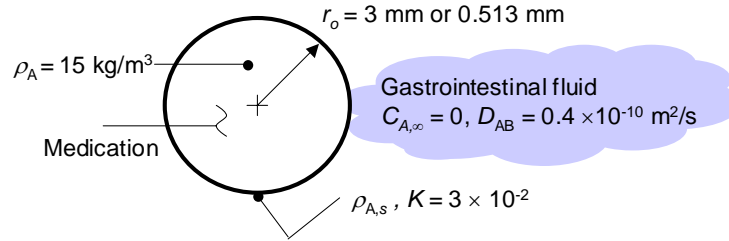

**ASSUMPTIONS:** (1) One-dimensional radial diffusion of active ingredient, (2) Constant properties, (3) Stationary medium, (4) Constant sphere radius.

**PROPERTIES:** Given:  $D_{AB} = 0.40 \times 10^{-10} \text{ m}^2/\text{s}$ ,  $K = 3 \times 10^{-2}$ .

**ANALYSIS:** (a) The approximate solution of Chapter 5 for external conduction from an isothermal sphere and the heat-mass transfer analogy will be used. From Table 5.2a,

$$q^*(Fo) = \frac{1}{\sqrt{\pi Fo}} + 1 \quad \text{or,} \quad \frac{q_s'' r_o}{k(T_s - T_\infty)} = \frac{r_o}{\sqrt{\pi \alpha t}} + 1 \quad (1,2)$$

By analogy, Eq. 2 may be written as

$$\frac{n_{A, s}'' r_o}{D_{AB}(\rho_{A, s} - \rho_{A, \infty})} = \frac{r_o}{\sqrt{\pi D_{AB} t}} + 1 \quad (3)$$

Rearranging,

$$n_{A, s}'' = \frac{\sqrt{D_{AB} / \pi} (\rho_{A, s} - \rho_{A, \infty})}{\sqrt{t}} + \frac{D_{AB} (\rho_{A, s} - \rho_{A, \infty})}{r_o}$$

For  $\rho_{A, \infty} = 0$ , the dosage (for  $A_s = 4\pi r_o^2$ ) is

$$D = \int_0^t 4\pi r_o^2 n_{A, s}'' dt = \int_0^t 4\pi r_o^2 \left[ \sqrt{D_{AB} / \pi} (\rho_{A, s}) t^{-1/2} + \frac{D_{AB} (\rho_{A, s})}{r_o} \right] dt$$

With  $\rho_{A, s} = K\rho_A$ , the preceding expression yields

$$D = 4\pi r_o K \rho_A \left[ 2r_o \sqrt{D_{AB} / \pi} t^{1/2} + D_{AB} t \right] \quad (4)$$

Continued...

### PROBLEM 14.45 (Cont.)

Substituting the appropriate values into Eq. 4 results in

$$D = 4\pi \times 3 \times 10^{-3} \text{ m} \times 3 \times 10^{-2} \times 15 \text{ kg/m}^3 \times \left[ \frac{2 \times 3 \times 10^{-3} \text{ m} \sqrt{0.4 \times 10^{-10} \text{ m}^2 / \text{s} \times 18000 \text{ s} / \pi}}{+0.4 \times 10^{-10} \text{ m}^2 / \text{s} \times 18000 \text{ s}} \right]$$

$$D = 60.9 \times 10^{-9} \text{ kg} = 60.9 \times 10^{-6} \text{ g} = 60.9 \text{ } \mu\text{g} \quad <$$

(b) For the same initial mass and  $N = 200$  tablets,

$$\frac{4}{3} \pi r_{o,1}^3 = \frac{N4}{3} \pi r_{o,N}^3 \quad \text{or} \quad r_{o,N} = r_{o,1} / N^{1/3} = 3 \times 10^{-3} \text{ m} / 200^{1/3} = 0.513 \text{ mm}$$

The dosage is  $D = ND_1$  where  $D_1$  is the dosage for one tablet. Hence,

$$D = ND_1 = 200 \times 4\pi \times 0.513 \times 10^{-3} \text{ m} \times 3 \times 10^{-2} \times 15 \text{ kg/m}^3 \times \left[ \frac{2 \times 0.513 \times 10^{-3} \text{ m} \sqrt{0.4 \times 10^{-10} \text{ m}^2 / \text{s} \times 18000 \text{ s} / \pi}}{+0.4 \times 10^{-10} \text{ m}^2 / \text{s} \times 18000 \text{ s}} \right]$$

$$D = 703 \times 10^{-9} \text{ kg} = 703 \times 10^{-6} \text{ g} = 703 \text{ } \mu\text{g} \quad <$$

**COMMENTS:** (1) The dosage is controlled by the tablet size. In this example, the medication dosage is increased by over an order of magnitude by replacing the single tablet with the encapsulated, smaller diameter spherical tablets. (2) The initial mass of the medication is  $M = 4/3 \rho \pi r_o^3 = 4/3 \times 15 \text{ kg/m}^3 \times \pi \times (3 \times 10^{-3} \text{ m})^3 = 1.696 \times 10^{-6} \text{ kg} = 1.696 \times 10^{-3} \text{ g} = 1.696 \text{ mg} = 1696 \text{ } \mu\text{g}$ . For the smaller tablets, the mass of medication left after 5 hours is  $1696 \text{ } \mu\text{g} - 703 \text{ } \mu\text{g} = 993 \text{ } \mu\text{g}$ . Hence, the tablet radius after 5 hours is  $r_{5h} = 0.513 \text{ mm} \times (993/1696)^{1/3} = 0.429 \text{ mm}$ . The assumption of a constant radius is marginally valid.

### PROBLEM 14.46

**KNOWN:** Thickness, initial condition and bottom surface condition of a water layer.

**FIND:** (a) Time to reach 25% of saturation at top, (b) Amount of salt transfer in that time, (c) Final concentration of salt solution at top and bottom.

**SCHEMATIC:**

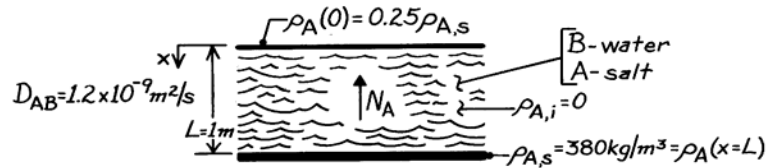

**ASSUMPTIONS:** (1) One-dimensional diffusion, (2) Uniform total mass density, (3) Constant  $D_{AB}$ , (4) Stationary medium.

**ANALYSIS:** (a) With constant  $\rho$  and  $D_{AB}$  and no homogeneous chemical reactions, Eq. 14.47b reduces to

$$\frac{\partial^2 \rho_A}{\partial x^2} = \frac{1}{D_{AB}} \frac{\partial \rho_A}{\partial t}.$$

with the origin of coordinates placed at the top of the layer, the dimensionless mass density is

$$\gamma^*(x^*, Fo_m) = \frac{\gamma}{\gamma_i} = \frac{\rho_A - \rho_{A,s}}{\rho_{A,i} - \rho_{A,s}} = 1 - \frac{\rho_A}{\rho_{A,s}}$$

Hence,  $\gamma^*(0, Fo_{m,1}) = 1 - 0.25 = 0.75$ . The initial condition is  $\gamma^*(x^*, 0) = 1$ , and the boundary conditions are

$$\left. \frac{\partial \gamma^*}{\partial x^*} \right|_{x^*=0} = 0 \quad \gamma^*(1, Fo_m) = 0$$

where the condition at  $x^* = 1$  corresponds to  $Bi_m = \infty$ . Hence, the mass transfer problem is analogous to the heat transfer problem governed by Eq. 5.38 through 5.40. Assuming applicability of a one-term approximation ( $Fo_m > 0.2$ ), the solution is analogous to Eq. 5.43.

$$\gamma^* = C_1 \exp(-\zeta_1^2 Fo_m) \cos(\zeta_1 x^*).$$

With  $Bi_m = \infty$ ,  $\zeta_1 = \pi/2 = 1.571$  rad and, from Table 5.1,  $C_1 \approx 1.273$ . Hence, for  $x^* = 0$ ,

$$0.75 = 1.273 \exp\left[-(1.571)^2 Fo_{m,1}\right]$$

$$Fo_{m,1} = -\ln(0.75/1.274)/(1.571)^2 = 0.214.$$

Hence,

$$t_1 = \frac{L^2}{D_{AB}} Fo_{m,1} = \frac{(1 \text{ m})^2}{1.2 \times 10^{-9} \text{ m}^2/\text{s}} 0.214 = 1.79 \times 10^8 \text{ s} = 2071 \text{ days.} \quad <$$

Continued ...

**PROBLEM 14.46 (Cont.)**

(b) The change in the salt mass within the water is

$$\Delta M_A = M_A(t_1) - M_{A,i} = \int (\rho_A - \rho_{A,i}) dV = A \int_0^L \rho_A dx$$

Hence,

$$\Delta M_A'' = \rho_{A,s} \int_0^L (\rho_A / \rho_{A,s}) dx$$

$$\Delta M_A'' = \rho_{A,s} L \int_0^1 (1 - \gamma^*) dx^*$$

$$\Delta M_A'' = \rho_{A,s} L \int_0^1 \left[ 1 - C_1 \exp(-\zeta_1^2 Fo_{m,1}) \cos(\zeta_1 x^*) \right] dx^*$$

$$\Delta M_A'' = \rho_{A,s} L \left[ 1 - C_1 \exp(-\zeta_1^2 Fo_{m,1}) \sin \zeta_1 / \zeta_1 \right].$$

Substituting numerical values,

$$\Delta M_A'' = 380 \text{ kg/m}^3 (1 \text{ m}) \left[ 1 - \frac{1.274 \exp[-(1.571)^2 0.214] 1}{1.571 \text{ rad}} \right]$$

$$\Delta M_A'' = 198.3 \text{ kg/m}^2. \quad <$$

(c) Steady-state conditions correspond to a uniform mass density in the water. Hence,

$$\rho_A(0, \infty) = \rho_A(L, \infty) = \Delta M_A'' / L = 198.3 \text{ kg/m}^3. \quad <$$

**COMMENTS:** (1) The assumption of constant  $\rho$  is weak, since the density of salt water depends strongly on the salt composition.

(2) The requirement of  $Fo_m > 0.2$  for the one-term approximation to be valid is barely satisfied.



## PROBLEM 14.47

**KNOWN:** Temperature distribution expression for a semi-infinite medium, initially at a uniform temperature, that is suddenly exposed to an instantaneous amount of energy,  $Q''_0$  ( $\text{J}/\text{m}^2$ ).

Analogous situation of a silicon (Si) wafer with a  $1\text{-}\mu\text{m}$  layer of phosphorous (P) that is placed in a furnace suddenly initiating diffusion of P into Si.

**FIND:** (a) Explain the correspondence between the variables in the analogous temperature and concentration distribution expressions, and (b) Determine the mole fraction of P at a depth of  $0.1\ \mu\text{m}$  in the Si after 30 s.

**SCHEMATIC:**

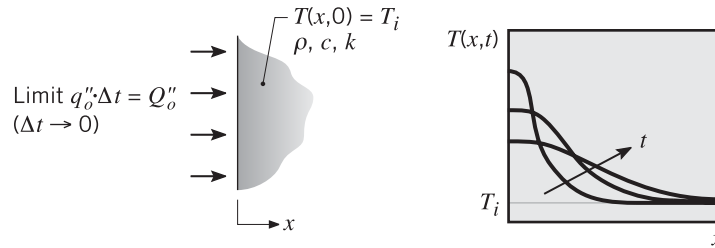

**ASSUMPTIONS:** (1) One-dimensional, transient diffusion, (2) Wafer approximates a semi-infinite medium, (3) Uniform properties, and (4) Diffusion process for Si and P is initiated when the wafer reaches the elevated temperature as a consequence of the large temperature dependence of the diffusion coefficient, (5) Stationary medium.

**PROPERTIES:** Given in statement:  $D_{\text{P-Si}} = 1.2 \times 10^{-17}\ \text{m}^2/\text{s}$ ; Mass densities of Si and P: 2000 and  $2300\ \text{kg}/\text{m}^3$ ; Molecular weights of Si and P: 30.97 and 28.09 kg/kmol.

**ANALYSIS:** (a) For the thermal process illustrated in the schematic, the temperature distribution is

$$T(x, t) - T_i = \frac{Q''_0}{\rho c (\pi \alpha t)^{1/2}} \exp(-x^2 / 4 \alpha t) \quad (\text{HT})$$

where  $T_i$  is the initial, uniform temperature of the medium. For the mass transfer process, the P concentration has the form

$$C_{\text{P}}(x, t) = \frac{M_{\text{P},0}^{\text{P}}}{(\pi D_{\text{P-Si}} t)^{1/2}} \exp(-x^2 / 4 D_{\text{P-Si}} t) \quad (\text{MT})$$

where  $M_{\text{P},0}^{\text{P}}$  is the molar area density ( $\text{kmol}/\text{m}^2$ ) of P represented by the film of concentration  $C_{\text{P}}$  and thickness  $d_0$ .

The correspondence between mass and heat transfer variables in the equations HT and MT involves the following conditions. The LHS represents the increase with time of the temperature or concentration above the initial uniform distribution. The initial concentration is zero, so only the  $C_{\text{P}}(x, t)$  appears. On the RHS note the correspondence of the terms in the exponential parenthesis and in the denominator. The thermal diffusivity and diffusion coefficient are directly analogous; this can be seen by comparing the MT and HT diffusion equations, Eq. 2.21 and 14.77. The terms  $Q''_0 / \rho c$  and  $M_{\text{P},0}^{\text{P}}$  for HT and MT represent the energy and mass instantaneously appearing at the surface. The product  $\rho c$  is the thermal capacity per unit area and appears in the storage term of the HT diffusion equation. For MT, the “capacity” term is the volume itself.

Continued ...

### PROBLEM 14.47 (Cont.)

(b) The molar area density ( $\text{kmol}/\text{m}^2$ ) of P associated with the film of thickness  $d_o = 1 \mu\text{m}$  and concentration  $C_{P,o}$  is

$$M_{P,o}^{\#} = C_{P,o} \cdot d_o = (\rho_P / M_P) d_o$$

$$M_{P,o}^{\#} = (2000 \text{ kg} / \text{m}^3 / 30.97 \text{ kmol} / \text{kg}) \times 1 \times 10^{-6} \text{ m}$$

$$M_{P,o}^{\#} = 6.458 \times 10^{-5} \text{ kmol} / \text{m}^2$$

Substituting numerical values into the MT equation, find

$$C_p(0.1 \mu\text{m}, 30 \text{ s}) = \frac{6.458 \times 10^{-5} \text{ kmol}/\text{m}^2}{(\pi \times 1.2 \times 10^{-17} \text{ m}^2/\text{s} \times 30 \text{ s})^{1/2}} \exp\left[-(0.1 \times 10^{-6} \text{ m})^2 / (4 \times 1.2 \times 10^{-17} \text{ m}^2/\text{s} \times 30 \text{ s})\right]$$

$$C_p = 1.85 \text{ kmol}/\text{m}^3$$

The mole fraction of P in the Si wafer is

$$x_P = C_P / C_{Si} = C_P / (\rho_{Si} / \mathcal{M}_{Si})$$

$$x_P = 1.85 \text{ kmol}/\text{m}^3 / (2300 \text{ kg}/\text{m}^3 / 28.09 \text{ kmol}/\text{kg})$$

$$x_P = 0.023$$

<

## PROBLEM 14.48

**KNOWN:** Carbon dioxide concentration at water surface and reaction rate constant.

**FIND:** (a) Differential equation which governs variation with position and time of CO<sub>2</sub> concentration in water, (b) Appropriate boundary conditions and solution for a deep body of water with negligible chemical reactions.

**SCHEMATIC:**

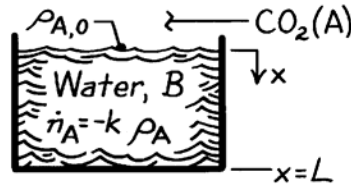

**ASSUMPTIONS:** (1) One-dimensional diffusion in  $x$ , (2) Constant properties, including total density  $\rho$ , (3) Water is stagnant, (4) Stationary medium.

**ANALYSIS:** (a) From Eq. 14.47b, it follows that, for the prescribed conditions,

$$D_{AB} \frac{\partial^2 \rho_A}{\partial x^2} - k_1 \rho_A = \frac{\partial \rho_A}{\partial t}. \quad <$$

The first term on the left-hand side represents the *net* transport of CO<sub>2</sub> into a differential control volume by diffusion. The second term represents the rate of CO<sub>2</sub> consumption due to chemical reactions. The term on the right-hand side represents the rate of increase of CO<sub>2</sub> storage within the control volume.

(b) For a deep body of water, appropriate boundary conditions are

$$\rho_A(0, t) = \rho_{A,0}$$

$$\rho_A(\infty, t) = 0$$

and, with negligible chemical reactions, the species diffusion equation reduces to

$$\frac{\partial^2 \rho_A}{\partial x^2} = \frac{1}{D_{AB}} \frac{\partial \rho_A}{\partial t}.$$

With an initial condition,  $\rho_A(x, 0) \equiv \rho_{A,i} = 0$ , the problem is analogous to that involving heat transfer in a semi-infinite medium with constant surface temperature. By analogy to Eq. 5.60, the species concentration is then

$$\frac{\rho_A(x, t) - \rho_{A,0}}{-\rho_{A,0}} = \operatorname{erf} \left( \frac{x}{2(D_{AB}t)^{1/2}} \right)$$

$$\rho_A(x, t) = \rho_{A,0} \operatorname{erfc} \left( \frac{x}{2(D_{AB}t)^{1/2}} \right). \quad <$$

### PROBLEM 14.49

**KNOWN:** Solubility and diffusivity of oxygen ( $O_2$ ) in polycarbonate. Distance of thin reacting film of polymer from DVD surface. Initial  $O_2$  distribution. Critical concentration needed to start reaction in the thin film.

**FIND:** Elapsed time before reaction begins in the thin film.

**SCHEMATIC:**

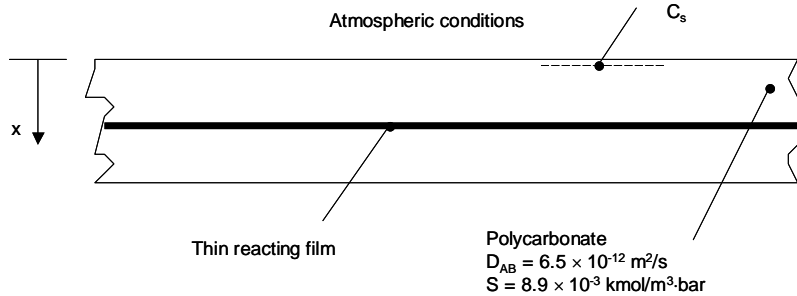

**ASSUMPTIONS:** (1) Constant properties and steady-state conditions, (2) Stationary medium. (3) Presence of thin, reacting film does not affect the diffusion process, (4) Semi-infinite media.

**PROPERTIES:** Oxygen ( $O_2$ ) in polycarbonate, given:  $D_{AB} = 6.5 \times 10^{-12} \text{ m}^2/\text{s}$ ,  $S = 8.9 \times 10^{-3} \text{ kmol}/\text{m}^3 \cdot \text{bar}$ .

**ANALYSIS:**

The mole fraction of oxygen in air is 0.21. Therefore, the partial pressure of  $O_2$  in the atmosphere is

$$P_{O_2} = 0.21 \text{ atm} \times 1.0133 \frac{\text{bar}}{\text{atm}} = 0.213 \text{ bar}$$

and the surface concentration is

$$C_s = C(x=0) = SP_{O_2} = 8.9 \times 10^{-3} \frac{\text{kmol}}{\text{m}^3 \cdot \text{bar}} \times 0.213 \text{ bar} = 1.89 \times 10^{-3} \frac{\text{kmol}}{\text{m}^3}$$

Incorporating the heat and mass transfer analogy and using Eq. 5.60,

$$\frac{C(x,t) - C_s}{C_i - C_s} = \text{erf} \left( \frac{x}{2\sqrt{D_{AB}t}} \right) = \frac{5 \times 10^{-5} \frac{\text{kmol}}{\text{m}^3} - 1.89 \times 10^{-3} \frac{\text{kmol}}{\text{m}^3}}{0 - 1.89 \times 10^{-3} \frac{\text{kmol}}{\text{m}^3}} = \text{erf} \left( \frac{0.5 \times 10^{-3} \text{ m}}{2\sqrt{6.5 \times 10^{-12} \frac{\text{m}^2}{\text{s}} \times t}} \right)$$

which yields

$$t = 3940 \text{ s}$$

<

**COMMENT:** The thin film will convert  $O_2$  to a product of the reaction. A more detailed analysis would include the effects of  $O_2$  conversion on the process.

### PROBLEM 14.50

**KNOWN:** DVD with reacting polymer throughout, undergoing first-order homogeneous reaction between polymer and oxygen, with reaction rate proportional to oxygen molar concentration.

**FIND:** (a) Governing equations and boundary and initial conditions for oxygen molar concentration. (b) Expression for volume-averaged molar concentration of product of reaction.

**SCHEMATIC:**

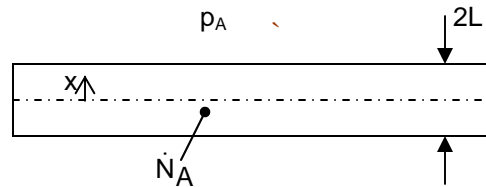

**ASSUMPTIONS:** (1) Constant properties, (2) One-dimensional mass diffusion with heterogeneous chemical reaction. (3) Reaction rate is proportional to molar concentration of oxygen.

**ANALYSIS:** (a) From Eq. 14.48b for one-dimensional diffusion of species A (oxygen),

$$\frac{\partial C_A}{\partial t} = D_{AB} \frac{\partial^2 C_A}{\partial x^2} + \dot{N}_A$$

For a first-order reaction that consumes oxygen, we can write  $\dot{N}_A = -k_1 C_A$ . Thus,

$$\frac{\partial C_A}{\partial t} = D_{AB} \frac{\partial^2 C_A}{\partial x^2} - k_1 C_A \quad <$$

The boundary conditions express symmetry about the midplane and relate the molar concentration at the surface to the partial pressure of oxygen in the environment,  $p_A$ .

$$\left. \frac{\partial C_A}{\partial x} \right|_{x=0} = 0, \quad C_A(L, t) = S p_A \quad <$$

The initial condition expresses that there is no oxygen initially in the DVD before the pouch is opened, that is,

$$C_A(x, 0) = 0 \quad <$$

(b) Since each mole of oxygen that reacts with the polymer results in  $p$  moles of product, we can write the following expression for the rate of generation of product:  $\dot{N}_{\text{prod}} = -p \dot{N}_A = p k_1 C_A$ .

Continued...

**PROBLEM 14.50 (Cont.)**

The volume-averaged molar concentration of product is just the rate of generation integrated over time and averaged over the volume. Thus,

$$\bar{C}_{\text{prod}} = \frac{1}{V} \int_V \int_0^t \dot{N}_{\text{prod}} dt dV = \frac{1}{2AL} \int_{-L}^L \int_0^t \dot{N}_{\text{prod}} dt (A dx) = \frac{1}{L} \int_0^L \int_0^t pk_1 C_A dt dx$$
$$\bar{C}_{\text{prod}} = \frac{pk_1}{L} \int_0^L \int_0^t C_A(x, t) dt dx \quad <$$

## PROBLEM 14.51

**KNOWN:** Sheet material has high, uniform concentration of hydrogen at the end of a process, and is then subjected to an air stream with a specified, low concentration of hydrogen. Mass transfer parameters specified include: convection mass transfer coefficient,  $h_m$ , and the mass diffusivity and solubility of hydrogen (A) in the sheet material (B),  $D_{AB}$  and  $S_{AB}$ , respectively.

**FIND:** (a) The final mass density of hydrogen in the material if the sheet is exposed to the air stream for a very long time,  $\rho_{A,f}$ , (b) Identify and evaluate the parameter that can be used to determine whether the transient mass diffusion process in the sheet can be characterized by a uniform concentration at any time; *Hint:* this situation is analogous to the lumped capacitance method for a transient heat transfer process; (c) Determine the time required to reduce the hydrogen concentration to twice the limiting value calculated in part (a).

**SCHEMATIC:**

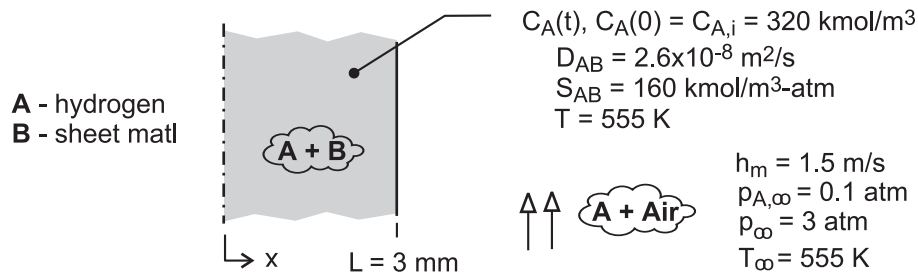

**ASSUMPTIONS:** (1) One-dimensional diffusion, (2) Stationary medium, (3) Constant properties, (4) Uniform temperature in air stream and material, and (5) Ideal gas behavior.

**ANALYSIS:** (a) The final content of  $\text{H}_2$  in the material will depend upon the solubility of  $\text{H}_2$  (A) in the material (B) and its partial pressure in the free stream. From Eq. 14.62,

$$C_{A,f} = S_{AB} p_{A,\infty} = 160 \text{ kmol/m}^3 \cdot \text{atm} \times 0.1 \text{ atm} = 16 \text{ kmol/m}^3$$

$$\rho_f = \mathcal{M}_A C_{A,f} = 2 \text{ kg/kmol} \times 16 \text{ kmol/m}^3 = 32 \text{ kg/m}^3 \quad \leftarrow$$

(b) The parameters associated with transient diffusion in the material follow from the analogous treatment of Section 5.2 (Fig. 5.3) and are represented in the schematic.

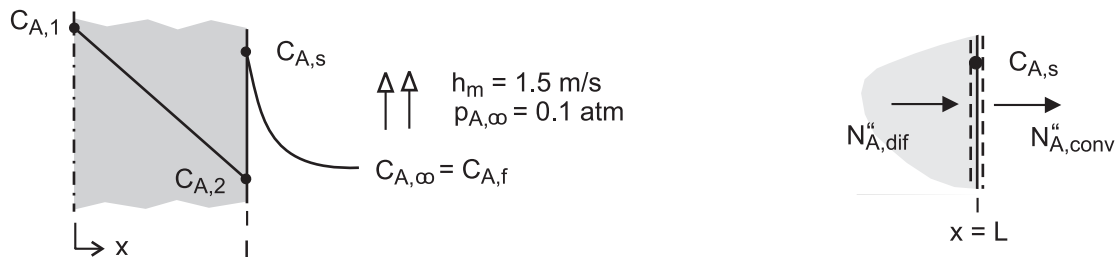

In the material, from Fick's law, the diffusive flux is

$$N''_{A,dif} = D_{AB} (C_{A,1} - C_{A,2}) / L \quad (1)$$

At the surface,  $x = L$ , the rate equation, Eq. 6.8, convective flux of species A is

$$N''_{A,conv} = h_m (C_{A,s} - C_{A,\infty})$$

Continued ...

**PROBLEM 14.51 (Cont.)**

and substituting the ideal gas law, Eq. 14.9, and introducing the solubility relation, Eq. 14.62,

$$N''_{A,\text{conv}} = \frac{h_m}{S_{AB} \mathcal{R} T_\infty} (S_{AB} p_{A,s} - S_{AB} p_{A,\infty})$$

$$N''_{A,\text{conv}} = \frac{h_m}{S_{AB} \mathcal{R} T_\infty} (C_{2,s} - C_{A,\infty}) \quad (2)$$

where  $C_{A,\infty} = C_{A,f}$ , the final concentration in the material after exposure to the air stream a long time. Considering a surface species flux balance, as shown in the schematic above, with the rate equations (1) and (2),

$$\frac{D_{AB} (C_{A,1} - C_{A,2})}{L} = \frac{h_m}{S_{AB} \mathcal{R} T_\infty} (C_{A,s} - C_{A,f})$$

$$\frac{C_{A,1} - C_{A,2}}{C_{A,s} - C_{A,f}} = \frac{h_m / S_{AB} \mathcal{R} T_\infty}{D_{AB} / L} = \frac{R''_{m,\text{dif}}}{R''_{m,\text{conv}}} = \text{Bi}_m \quad (3)$$

and introducing resistances to species transfer by diffusion and convection. Recognize from the analogy to heat transfer, Eq. 5.10 and Table 14.2, that when  $\text{Bi}_m < 0.1$ , the concentration can be characterized as uniform during the transient process. That is, the diffusion resistance is negligible compared to the convection resistance,

$$\text{Bi}_m = \frac{h_m L}{S_{AB} R_u T_\infty D_{AB}} < 0.1 \quad (4)$$

$$\text{Bi}_m = \frac{(1.5 \text{ m/h} \times 3600 \text{ s/h}) \times 0.003 \text{ m}}{160 \text{ kmol/m}^3 \cdot \text{atm} \times 8.205 \times 10^{-2} \text{ m}^3 \cdot \text{atm/kmol} \cdot \text{K} \times 555 \text{ K} \times 2.68 \times 10^{-8} \text{ m}^2/\text{s}}$$

$$\text{Bi}_m = 6.60 \times 10^{-3} < 0.1$$

Hence, the mass transfer process can be treated as a nearly uniform concentration situation. From conservation of species on the material with uniform concentration,

$$-N''_{A,\text{conv}} = \dot{N}''_{A,\text{st}}$$

$$-\frac{h_m}{S_{AB} \mathcal{R} T_\infty} (C_A - C_{A,f}) = L \frac{dC_A}{dt}$$

Integrating, with the initial condition  $C_A(0) = C_{A,i}$ , find

$$\frac{C_A - C_{A,f}}{C_{A,i} - C_{A,f}} = \exp\left(-\frac{h_m t}{L S_{AB} \mathcal{R} T_\infty}\right) \quad (5) <$$

Continued .....



### PROBLEM 14.51 (Cont.)

which is similar to the analogous heat transfer relation for the lumped capacitance analysis, Eq. 5.6.

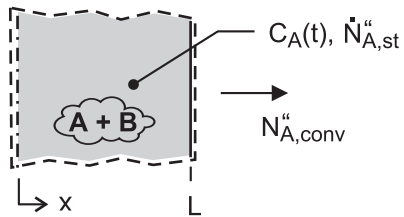

(c) The time,  $t_o$ , required for the material to reach a concentration twice that of the limiting value,  $C_A(T_o) = 2 C_{A,f}$ , can be calculated from Eq. (5).

$$\frac{(2-1) \times 16 \text{ kmol/m}^3}{(320-16) \text{ kmol/m}^3} = \exp\left(-\frac{1.5 \text{ m/h} \times t_o}{0.003 \text{ m} \times 160 \text{ kmol/m}^3 \cdot \text{atm} \times 8.205 \times 10^{-2} \text{ m}^3 \cdot \text{atm/kmol} \cdot \text{K} \times 555 \text{ K}}\right)$$

$$t_o = 42.9 \text{ h}$$

<

## PROBLEM 14.52

**KNOWN:** Hydrogen-removal process described in Problem 14.51, but under conditions for which the mass diffusivity of hydrogen gas (A) in the sheet (B) is  $D_{AB} = 1.8 \times 10^{-11} \text{ m}^2/\text{s}$  (instead of  $2.6 \times 10^{-8} \text{ m}^2/\text{s}$ ). With a smaller  $D_{AB}$ , a uniform concentration condition may no longer be assumed to exist in the material during the removal process.

**FIND:** (a) The final mass density of hydrogen in the material if the sheet is exposed to the air stream for a very long time,  $\rho_{A,f}$ , (b) Identify and evaluate the parameters that describe the transient mass transfer process in the sheet; *Hint:* this situation is analogous to that of transient heat conduction in a plane wall; (c) Assuming a uniform concentration in the sheet at any time during the removal process, determine the time required to reach twice the limiting mass density calculated in part (a); (d) Using the analogy developed in part (b), determine the time required to reduce the hydrogen concentration to twice the limiting value calculated in part (a); Compare the result with that from part (c).

**SCHEMATIC:**

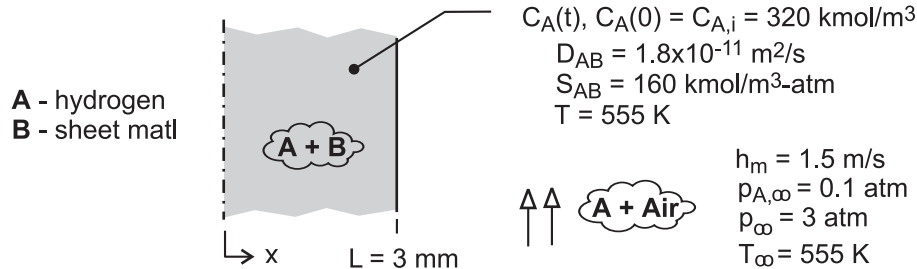

**ASSUMPTIONS:** (1) One-dimensional diffusion, (2) Stationary medium, (3) Constant properties, (4) Uniform temperature in air stream and material, and (5) Ideal gas behavior.

**ANALYSIS:** (a) The final content of  $\text{H}_2$  in the material will depend upon the solubility of  $\text{H}_2$  (A) in the material (B) at its partial pressure in the free stream. From Eq. 14.62,

$$C_{A,f} = S_{AB} p_{A,\infty} = 160 \text{ kmol/m}^3 \cdot \text{atm} \times 0.1 \text{ atm} = 16 \text{ kmol/m}^3$$

$$\rho_f = M_A C_{A,f} = 2 \text{ kg/kmol} \times 16 \text{ kmol/m}^3 = 32 \text{ kg/m}^3 \quad <$$

(b) For the plane wall shown in the schematic below, the heat and mass transfer conservation equations and their initial and boundary conditions are

*Heat transfer*

$$\frac{\partial T}{\partial t} = \alpha \frac{\partial^2 T}{\partial x^2}$$

$$T(x,0) = T_i$$

$$\frac{\partial T}{\partial x}(0,t) = 0$$

$$-k \frac{\partial T}{\partial x}(L,t) = h[T(L,t) - T_\infty]$$

*Mass (Species A) transfer*

$$\frac{\partial C_A}{\partial t} = D_{AB} \frac{\partial^2 C_A}{\partial x^2}$$

$$C_A(x,0) = C_{A,i}$$

$$\frac{\partial C_A}{\partial x}(0,t) = 0$$

$$-D_{AB} \frac{\partial C_A}{\partial x}(L,t) = \frac{h_m}{S_{AB} \mathcal{R} T} [C_A(x,t) - C_f]$$

Continued ...

**PROBLEM 14.52 (Cont.)**

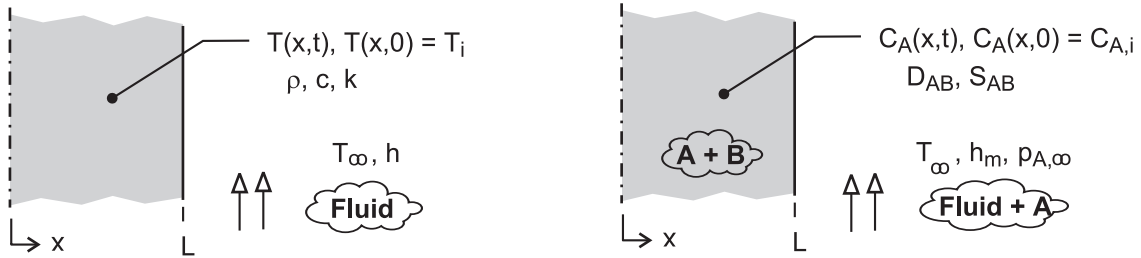

The derivation for the species transport surface boundary condition is developed in the solution for Problem 14.51. The solution to the mass transfer problem is identical to the analogous heat transfer problem provided the transport coefficients are represented as

$$\frac{h}{k} \Leftrightarrow \frac{h_m / S_{AB} \mathcal{R} T}{D_{AB}} \quad (1)$$

(c) The uniform concentration transient diffusion process is analogous to the heat transfer lumped-capacitance process. From the solution of Problem 14.51, the time to reach twice the limiting concentration,  $C_A(t_0) = 2 C_{A,f}$ , can be calculated as

$$\frac{C_A(t_0) - C_{A,f}}{C_{A,i} - C_{A,f}} = \exp\left(-\frac{h_m t_0}{L S_{AB} \mathcal{R} T}\right) \quad (2)$$

$$t_0 = 42.9 \text{ hour}$$

<

For the present situation, the mass transfer Biot number is

$$Bi_m = \frac{h_m L}{S_{AB} \mathcal{R} T D_{AB}}$$

$$Bi_m = \frac{(1.5 \text{ m/h} / 3600 \text{ s/h}) \times 0.003 \text{ m}}{160 \text{ kmol/m}^3 \cdot \text{atm} \times 8.205 \times 10^{-2} \text{ m}^3 \cdot \text{atm/kmol} \cdot \text{K} \times 555 \text{ K} \times 1.8 \times 10^{-11} \text{ m}^2/\text{s}}$$

$$Bi_m = 9.5 \gg 0.1$$

and hence the concentration of A within B is not uniform

(d) Invoking the analogy with the heat transfer situation, we can use the one-term series solution, Eq. 5.43, with  $Bi_m \Leftrightarrow Bi$  and

$$Fo_m \Leftrightarrow Fo \quad Fo_m = \frac{D_{AB} t}{L^2} \quad (3)$$

Continued ...

### PROBLEM 14.52 (Cont.)

With  $Bi_m = 9.5$ , find  $\zeta_1 = 1.4219$  rad and  $C_1 = 1.2609$  from Table 5.1, so that Eq. 5.44 becomes

$$\frac{C_A(t_o) - C_{A,f}}{C_{A,i} - C_{A,f}} = C_1 \exp(-\zeta_1^2 Fo_m)$$

$$\frac{(2-1) \times 16 \text{ kmol/m}^3}{(320-16) \text{ kmol/m}^3} = 1.2609 \exp(-1.4219^2 Fo_m)$$

$$Fo_m = \frac{1.8 \times 10^{-11} \text{ m}^2/\text{s} \times t_o}{(0.003 \text{ m})^2} = 1.571$$

$$t_o = 218 \text{ h}$$

<

**COMMENTS:** (1) Since  $Bi_m = 9.5$ , the uniform concentration assumption is not valid, and we expect the analysis to provide a longer time estimate to reach  $C_A(t_o) = 2 C_{A,f}$ .

(2) Note that the uniform concentration analysis model of part (c) does not include  $D_{AB}$ . Why is this so?

### PROBLEM 14.53

**KNOWN:** Dimensions of polymer sheet. Temperature and relative humidity of environment. Increase in mass of sheet over 24 and 48 hour periods.

**FIND:** Solubility and mass diffusivity of water vapor in polymer, assuming mass diffusivity is greater than  $7 \times 10^{-13} \text{ m}^2/\text{s}$ .

**SCHEMATIC:**

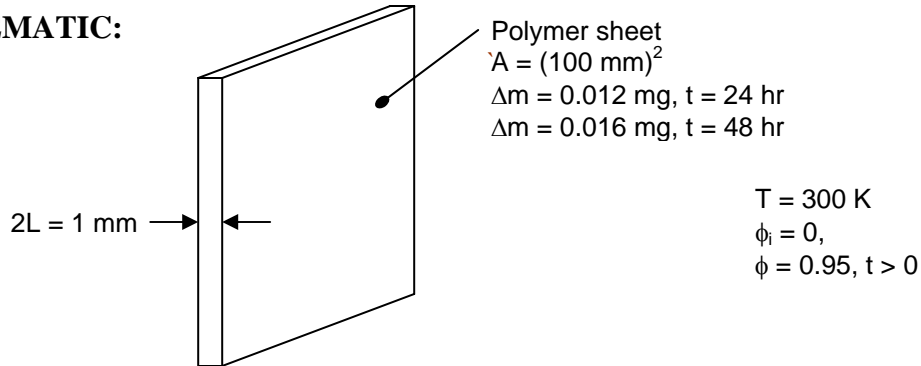

**ASSUMPTIONS:** (1) Constant properties, (2) One-dimensional mass diffusion, (3) Mass gain is solely due to water vapor diffusing into the sheet.

**PROPERTIES:** Table A.6, saturated water ( $T = 300 \text{ K}$ ),  $p_{A,\text{sat}} = 0.03531 \text{ bars}$ ,  $\mathcal{M}_A = 18 \text{ kg/kmol}$ .

**ANALYSIS:** The process of diffusion of water vapor (A) in the polymer (B) sheet is governed by Eq. 14.77 with boundary and initial conditions given by Eqs. 14.78 through 14.80. These equations can be cast in nondimensional form as in Eqs. 14.83 through 14.86, and the analogy with Eqs. 5.37 through 5.40 is apparent (for  $\text{Bi} \rightarrow \infty$ ), with the analogous quantities defined in Table 14.2.

Since the mass gained by the polymer sheet is known, it is more convenient to work the problem in mass terms. Making use of Eq. 14.1, we recognize that  $\gamma^*$  defined in Eq. 14.81 can be written in the alternative form,

$$\gamma^* = \frac{C_A - C_{A,s}}{C_{A,i} - C_{A,s}} = \frac{\rho_A - \rho_{A,s}}{\rho_{A,i} - \rho_{A,s}} \quad (1)$$

Here  $\rho_{A,i} = 0$  since the sheet is initially dry, and  $\rho_{A,s} = \mathcal{M}_A C_{A,s} = \mathcal{M}_A S p_{A,\infty}$ , or

$$\rho_{A,s} = \mathcal{M}_A S \phi p_{A,\text{sat}} \quad (2)$$

where  $S$  is the solubility (see Eq. 14.62).

The mass gained by the polymer sheet is then analogous to the energy transfer,  $Q$ , in the heat transfer problem. Specifically, for the mass loss, we can write a sequence of equations analogous to Eqs. 5.46 through 5.48,

Continued...

**PROBLEM 14.53 (Cont.)**

$$\text{Mass loss} = \Delta M_A = -[M_A(t) - M_A(0)] = -\int [\rho_A(x, t) - \rho_{A,i}] dV$$

$$\Delta M_{A,0} \equiv V(\rho_{A,i} - \rho_{A,s})$$

and

$$\frac{\Delta M_A}{\Delta M_{A,0}} = -\int \frac{[\rho_A(x, t) - \rho_{A,i}]}{\rho_{A,i} - \rho_{A,s}} \frac{dV}{V} = \frac{1}{V} \int (1 - \gamma^*) dV$$

If  $Fo_m > 0.2$ , the solution can be approximated by the first term in the series, and the result for the mass loss would be analogous to Eq. 5.49. To determine if the first term approximation can be used, we estimate the mass transfer Fourier number with knowledge that the mass diffusivity is greater than  $7 \times 10^{-13} \text{ m}^2/\text{s}$ ,

$$Fo_m = D_{AB}t/L^2, \quad Fo_m > 7 \times 10^{-13} \text{ m}^2/\text{s} \times 24 \text{ h} \times 3600 \text{ s/h} / (0.0005 \text{ m})^2 = 0.24$$

Thus the one-term approximation is valid and by analogy to Eqs. 5.49 and 5.44, the nondimensional mass loss is given by

$$\frac{\Delta M_A}{\Delta M_{A,0}} = 1 - \frac{\sin \zeta_1}{\zeta_1} C_1 \exp(-\zeta_1^2 Fo_m) \quad (3)$$

or

$$\frac{-\Delta M_A}{\rho_{A,s} V} = 1 - \frac{\sin \zeta_1}{\zeta_1} C_1 \exp(-\zeta_1^2 \frac{D_{AB}}{L^2} t) \quad (4)$$

From Table 5.1 for  $Bi \rightarrow \infty$ , we find  $\zeta_1 = 1.5707 = \pi/2$  and  $C_1 = 1.2733$ . The quantity  $-\Delta M_A$  is the mass gain at the two stated times. The unknowns to be determined are  $D_{AB}$  and  $S$ , which appears in  $\rho_{A,s}$  (see Eq. (2)). From Eq. (4) evaluated at the two times, we have two simultaneous equations which can be solved for the unknowns  $D_{AB}$  and  $\rho_{A,s}$ , namely

$$\frac{0.012 \times 10^{-6} \text{ kg}}{\rho_{A,s} \times 10^{-5} \text{ kg/m}^3} = 1 - \frac{\sin \pi/2}{\pi/2} 1.2733 \exp\left(-\frac{\pi^2}{4} \frac{D_{AB}}{(0.0005 \text{ m})^2} 24 \text{ h} \times 3600 \text{ s/h}\right)$$

$$\frac{0.016 \times 10^{-6} \text{ kg}}{\rho_{A,s} \times 10^{-5} \text{ kg/m}^3} = 1 - \frac{\sin \pi/2}{\pi/2} 1.2733 \exp\left(-\frac{\pi^2}{4} \frac{D_{AB}}{(0.0005 \text{ m})^2} 48 \text{ h} \times 3600 \text{ s/h}\right)$$

There are two solutions to these two equations,

$$D_{AB} = 1.92 \times 10^{-13} \text{ m}^2/\text{s}, \quad \rho_{A,s} = 0.003848 \text{ kg/m}^3$$

or

$$D_{AB} = 8.5 \times 10^{-13} \text{ m}^2/\text{s}, \quad \rho_{A,s} = 0.001976 \text{ kg/m}^3$$

Continued...

### PROBLEM 14.53 (Cont.)

Since we expect  $D_{AB}$  to be greater than  $7 \times 10^{-13} \text{ m}^2/\text{s}$ , we choose the second solution. Thus,

$$D_{AB} = 8.5 \times 10^{-13} \text{ m}^2/\text{s} \quad <$$

$$S = \rho_{A,S} / \mathcal{M}_A \phi_{A,\text{sat}} = 0.001976 \text{ kg/m}^3 / (18 \text{ kg/kmol} \times 0.95 \times 0.03531 \text{ bars})$$

$$S = 3.3 \times 10^{-3} \text{ kmol/m}^3 \cdot \text{bar} \quad <$$

**COMMENTS:** The system of equations has two solutions, but one of them would yield a mass diffusivity less than  $7 \times 10^{-13} \text{ m}^2/\text{s}$ , and is therefore rejected. That solution also has  $Fo_m < 0.2$ , so the solution is not valid. It does raise the question of whether there is another solution for which  $Fo_m < 0.2$ . If the problem is solved correctly for  $Fo_m < 0.2$ , it can be determined that there is no other solution.

### PROBLEM 14.54

**KNOWN:** Diameter of optical fiber sensor in a hydrogen chamber. Pressure of hydrogen (species A) in environment. Mass diffusivity and solubility for hydrogen in glass fiber (species B).

**FIND:** (a) Average hydrogen concentration in fiber after 100 hours of operation. Change in refractive index, given that  $\Delta n = (1.6 \times 10^{-3} \text{ m}^3/\text{kmol}) \times \bar{C}$ . (b) Average hydrogen concentration and change in refractive index after 1 and 10 hours of operation.

**SCHEMATIC:**

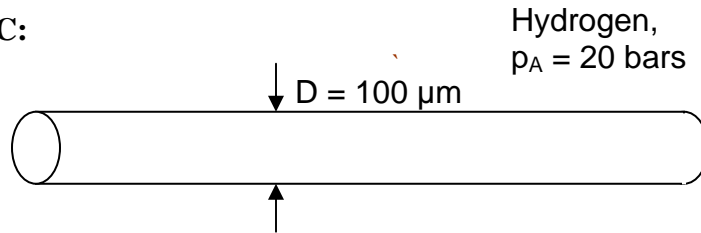

**ASSUMPTIONS:** (1) Constant properties, (2) One-dimensional mass diffusion.

**PROPERTIES:** Hydrogen in vitreous silica fiber (given):  $D_{AB} = 2.88 \times 10^{-15} \text{ m}^2/\text{s}$ ,  $S = 4.15 \times 10^{-3} \text{ kmol}/\text{m}^3 \cdot \text{bar}$ .

**ANALYSIS:** (a) This is a problem of transient mass diffusion in a cylinder, analogous to transient conduction in a cylinder. We begin by calculating the mass transfer Fourier number,

$$Fo_m = D_{AB}t/r_0^2 = 2.88 \times 10^{-15} \text{ m}^2/\text{s} \times 100 \text{ h} \times 3600 \text{ s/h} / (50 \times 10^{-6} \text{ m})^2 = 0.415$$

With  $Fo_m > 0.2$ , we can use the first-term approximation to the series solution. The average hydrogen concentration can be found by analogy with the nondimensional energy transfer  $Q/Q_0$  defined in Eq. 5.48, with reference to Table 14.3 for the analogous quantities. We define

$$\frac{\Delta M_A}{\Delta M_{A,0}} \equiv \int \frac{-(C_A(x,t) - C_{A,i})}{C_{A,i} - C_{A,s}} \frac{dV}{V} = \frac{1}{V} \int (1 - \gamma^*) dV \quad (1)$$

Here the surface concentration,  $C_{A,s}$ , is used in place of the environment temperature,  $T_\infty$ , because this is a problem of specified surface concentration, modeled by allowing  $Bi_m \rightarrow \infty$ . By analogy with Eq. 5.54,

$$\frac{\Delta M_A}{\Delta M_{A,0}} = 1 - \frac{2\gamma_0^*}{\zeta_1} J_1(\zeta_1)$$

where from Eq. 5.52c, the centerline value of the nondimensional molar concentration is  $\gamma_0^* = C_1 \exp(-\zeta_1^2 Fo_m)$ . From Table 5.1,  $\zeta_1 = 2.4050$ ,  $C_1 = 1.6018$ , so  $\gamma_0^* = 0.145$ . From Table B.4,  $J_1(2.4050) \approx 0.52$ . Thus,

Continued...



**PROBLEM 14.54 (Cont.)**

$$\frac{\Delta M_A}{\Delta M_{A,0}} = 1 - \frac{2 \times 0.145}{2.4050} \times 0.52 = 0.937$$

Referring back to Eq. (1), we can determine the average hydrogen concentration,

$$\bar{C}_A = \int C_A(x, t) \frac{dV}{V} = C_{A,i} + \frac{\Delta M_A}{\Delta M_{A,0}} (C_{A,s} - C_{A,i})$$

where  $C_{A,i} = 0$  since the fiber initially contains no hydrogen, and  $C_{A,s} = Sp_A = 4.15 \times 10^{-3} \text{ kmol/m}^3 \cdot \text{bar} \times 20 \text{ bars} = 0.0830 \text{ kmol/m}^3$ . Thus,

$$\bar{C}_A = 0 + 0.937(0.0830 \text{ kmol/m}^3 - 0) = 0.0778 \text{ kmol/m}^3 \quad <$$

The change in refractive index is then

$$\Delta n = 1.6 \times 10^{-3} \text{ m}^3/\text{kmol} \times 0.0778 \text{ kmol/m}^3 = 1.24 \times 10^{-4}$$

(b) For the shorter times, the Fourier number is no longer larger than 0.2, and we must use a different approach. We could use the exact infinite series solution, but it is easier to use the solutions provided in Table 5.2a, which are appropriate for uniform surface concentration. For an infinite cylinder, with  $L_c = r_0$ ,

$$q^* = q_s'' r_0 / k(T_s - T_i)$$

The analogous quantity is

$$N_A^* = N_{A,s}'' r_0 / D_{AB}(C_{A,s} - C_{A,i})$$

With knowledge of the molar flux at the surface,  $N_{A,s}''$ , the average hydrogen concentration can be found as follows. We multiply the flux by the surface area and integrate over time to find how much hydrogen has entered the fiber. Then we divide by the volume to find the average concentration. That is,

$$\bar{C}_A = \int_0^t N_{A,s}'' dt \times \frac{2\pi r_0}{\pi r_0^2} = \frac{2}{r_0} \int_0^t N_{A,s}'' dt$$

Now from Table 5.2a for the interior case, infinite cylinder, with  $Fo_m < 0.2$ ,

$$N_A^* = N_{A,s}'' r_0 / D_{AB}(C_{A,s} - C_{A,i}) = \frac{1}{\sqrt{\pi Fo_m}} - 0.50 - 0.65 Fo_m$$

Thus, we have

Continued...

**PROBLEM 14.54 (Cont.)**

$$\begin{aligned}\bar{C}_A &= \frac{2}{r_0} \int_0^t N''_{A,s} dt = \frac{2}{r_0^2} D_{AB} (C_{A,s} - C_{A,i}) \int_0^t \left( \frac{1}{\sqrt{\pi Fo_m}} - 0.50 - 0.65 Fo_m \right) dt \\ &= 2(C_{A,s} - C_{A,i}) \int_0^{Fo_m} \left( \frac{1}{\sqrt{\pi Fo_m}} - 0.50 - 0.65 Fo_m \right) dFo_m \\ &= 2(C_{A,s} - C_{A,i}) \left( \frac{2Fo_m^{1/2}}{\sqrt{\pi}} - 0.50 Fo_m - \frac{0.65}{2} Fo_m^2 \right)\end{aligned}$$

At 1 hour and 10 hours,  $Fo_m = 0.00415$  and  $0.0415$ , respectively. Then with  $C_{A,s} = 0.0830$  kmol/m<sup>3</sup> and  $C_{A,i} = 0$ , we find,

$$\text{For } t = 1 \text{ hr, } \bar{C}_A = 0.0117 \text{ kmol/m}^3, \quad \Delta n = 1.9 \times 10^{-5} \quad <$$

$$\text{For } t = 10 \text{ hr, } \bar{C}_A = 0.0346 \text{ kmol/m}^3, \quad \Delta n = 5.5 \times 10^{-5} \quad <$$

**COMMENTS:** (1) Hydrogen diffusion into glass optical fibers is highly undesirable because of the effects described in the problem statement. Hermetic coatings are typically applied to the fibers to prevent diffusion of hydrogen and other unwanted species into the glass. (2) At  $t = 100$

hours,  $\gamma_0^* = \frac{C_A(0,t) - C_{A,s}}{C_{A,i} - C_{A,s}} = 0.145$ . This tells us that the centerline concentration is within

14.5% of reaching the surface concentration. At the same time, the *average* molar concentration is 93.7% of the surface concentration, i.e. within 6.3% of reaching the surface concentration. This is because of the radial geometry, which has greater volume near the surface than near the centerline.

## PROBLEM 14.55

**KNOWN:** Diameters of glass optical fiber and acrylate polymer coating. Mass diffusivity of water vapor in the acrylate.

**FIND:** Whether microcracking would occur within several hot and humid days.

**SCHEMATIC:**

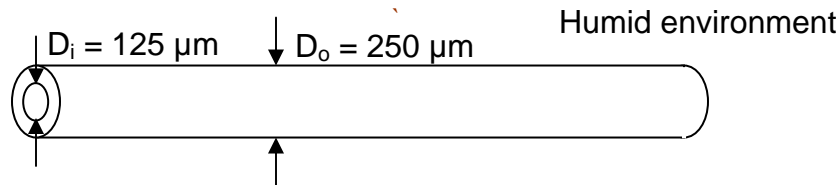

**ASSUMPTIONS:** (1) One-dimensional mass diffusion. (2) Use of acrylate properties throughout the cylinder is sufficient for estimating the diffusion process in order to answer the question.

**PROPERTIES:** Water vapor in acrylate polymer (given):  $D_{AB} = 5.5 \times 10^{-13} \text{ m}^2/\text{s}$ .

**ANALYSIS:** We arbitrarily begin by considering a two-day period. Then the mass transfer Fourier number is,

$$Fo_m = D_{AB}t/r_o^2 = 5.5 \times 10^{-13} \text{ m}^2/\text{s} \times 48 \text{ h} \times 3600 \text{ s/h} / (125 \times 10^{-6} \text{ m})^2 = 6.1$$

Since  $Fo_m > 0.2$ , we can use the one-term approximation, analogous to Eq. 5.49a. Referring to Table 14.3 for the analogies,

$$\gamma^* = \frac{C_A(r, t) - C_{A,s}}{C_{A,i} - C_{A,s}} = C_1 \exp(-\zeta_1^2 Fo_m) J_0(\zeta_1 r^*) \quad (1)$$

where from Table 5.1, as  $Bi \rightarrow \infty$ ,  $\zeta_1 = 2.4050$ ,  $C_1 = 1.6018$ . At the outer surface of the glass,  $r^* = 0.5$  and from Table B.4,  $J_0(2.4050 \times 0.5) \approx J_0(1.2) \approx 0.67$ . Thus

$$\gamma^* = 1.6018 \exp(-2.4050^2 \times 6.1) \times 0.67 = 5.6 \times 10^{-16}$$

Referring to the definition of  $\gamma^*$  in Eq. (1), we see that this very small value means that the concentration has essentially already reached the surface concentration. Therefore, careful storage of the optical fiber will not prevent microcracking, since within two days (probably much less), the water vapor has penetrated through the acrylate polymer coating. <

**COMMENTS:** (1) Equation 5.52 assumes uniform properties throughout the cylinder. Since the glass is impermeable to moisture, the build-up of moisture in the coating would be even more rapid than this equation predicts. (2) The time required for the concentration to be within 5% of the surface concentration ( $\gamma^* = 0.05$ ) is around four hours. (3) Development of *hermetic coatings* for use in fiber optic and other high technology applications is an ongoing area of research.

## PROBLEM 14.56

**KNOWN:** Mass of insect repellent applied to known area of skin. Convective mass transfer coefficient, partition coefficient at the ingredient – skin interface, mass diffusivity of the ingredient in the skin.

**FIND:** (a) Initial thickness of the active ingredient, (b) Duration of effective treatment, (c) Duration of effective treatment with use of reformulated repellent with a very small partition coefficient.

**SCHEMATIC:**

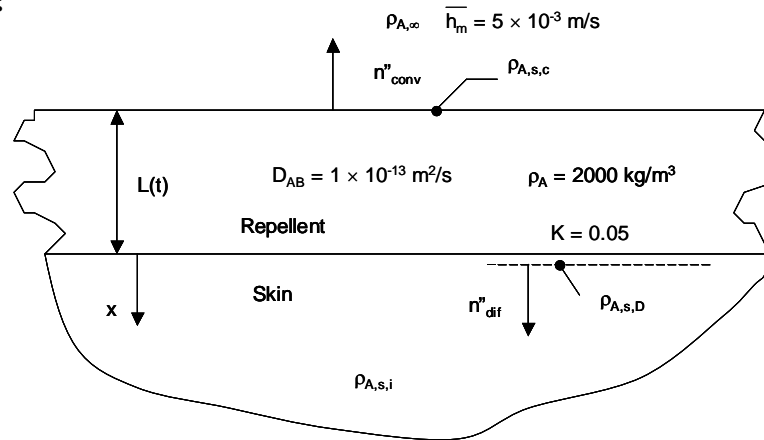

**ASSUMPTIONS:** (1) Constant properties and steady-state conditions, (2) Stationary medium. (3) Skin is semi-infinite medium.

**PROPERTIES:** Active Ingredient, given:  $\rho_A = 2000 \text{ kg/m}^3$ ,  $\mathcal{M}_A = 152 \text{ kg/kmol}$ ,  $p_{A,\text{sat}} = 1.2 \times 10^{-5} \text{ bars}$ ,  $K$  (active Ingredient-skin interface) = 0.05,  $D_{AB}$  (active ingredient in skin) =  $1 \times 10^{-13} \text{ m}^2/\text{s}$ .

**ANALYSIS:**

(a) For an active ingredient volume fraction of  $f = 0.25$ , the initial thickness of the active ingredient is

$$L(t=0) = \frac{fM}{\rho_A A} = \frac{0.25 \times 10 \times 10^{-3} \text{ kg}}{2000 \frac{\text{kg}}{\text{m}^3} \times 0.5 \text{ m}^2} = 2.5 \times 10^{-6} \text{ m} = 2.5 \mu\text{m} \quad <$$

(b) The duration of the effective treatment is associated with the complete depletion of the active ingredient through combined evaporation and absorption. For absorption of the ingredient into the skin, the analogy to Eq. 5.61 may be employed to provide

$$L(t=0) = \frac{1}{\rho_A} \left[ \int_0^t n''_{A,\text{conv}} dt + \int_0^t n''_{A,\text{dif}} dt \right] = \frac{1}{\rho_A} \left[ \int_0^t h_m (\rho_{A,s,c} - \rho_{A,\infty}) dt + \int_0^t \frac{\sqrt{D_{AB}}}{\sqrt{\pi t}} (\rho_{A,s,D} - \rho_{A,i}) dt \right]$$

Continued...

### PROBLEM 14.56 (Cont.)

Noting that  $\rho_{A,\infty} = \rho_{A,i} = 0$  and  $\rho_{A,s,D} = K\rho_A$ , the integrations may be carried out to yield

$$L(t=0) = \frac{1}{\rho_A} \left[ \bar{h}_m (\rho_{A,s,c}) t \right] + 2 \frac{\sqrt{D_{AB} K}}{\sqrt{\pi}} \sqrt{t}$$

The surface concentration of the active ingredient is

$$\rho_{A,s,c} = \frac{p_{A,\text{sat}}(T_s)}{(\mathcal{R}/M_A)T_s} = \frac{1.2 \times 10^{-5} \text{ bar}}{(8.314 \times 10^{-2} \text{ m}^3 \cdot \text{bar}/\text{kmol} \cdot \text{K}/152 \text{ kmol}/\text{kg}) \times (273 + 32)\text{K}} = 71.9 \times 10^{-6} \text{ kg}/\text{m}^3$$

Substituting the values of  $L(t=0)$ ,  $\rho_{A,s,c}$ , and the quantities given in the problem statement, the preceding equation may be solved to yield

$$t = 6130 \text{ s or } 1.7 \text{ h} \quad <$$

(c) Setting  $K = 0$ , the preceding equation may be solved again to yield

$$t = 13900 \text{ s or } 3.9 \text{ h} \quad <$$

**COMMENT:** In part (b), convective losses are 43% of the total loss, while losses due to diffusion into the skin are 57%.

### PROBLEM 4S.1

**KNOWN:** Long furnace of refractory brick with prescribed surface temperatures and material thermal conductivity.

**FIND:** Shape factor and heat transfer rate per unit length using the flux plot method

**SCHEMATIC:**

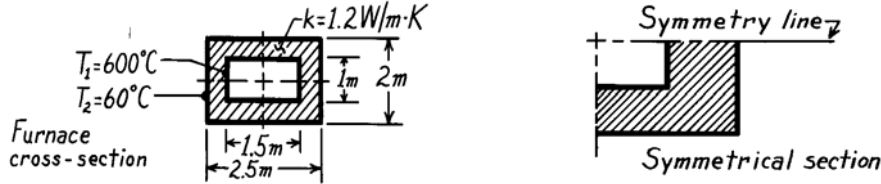

**ASSUMPTIONS:** (1) Furnace length normal to page,  $\ell$ ,  $\gg$  cross-sectional dimensions, (2) Two-dimensional, steady-state conduction, (3) Constant properties.

**ANALYSIS:** Considering the cross-section, the cross-hatched area represents a symmetrical element. Hence, the heat rate for the entire furnace per unit length is

$$q' = \frac{q}{\ell} = 4 \frac{S}{\ell} k (T_1 - T_2) \quad (1)$$

where  $S$  is the shape factor for the symmetrical section. Selecting three temperature increments ( $N = 3$ ), construct the flux plot shown below.

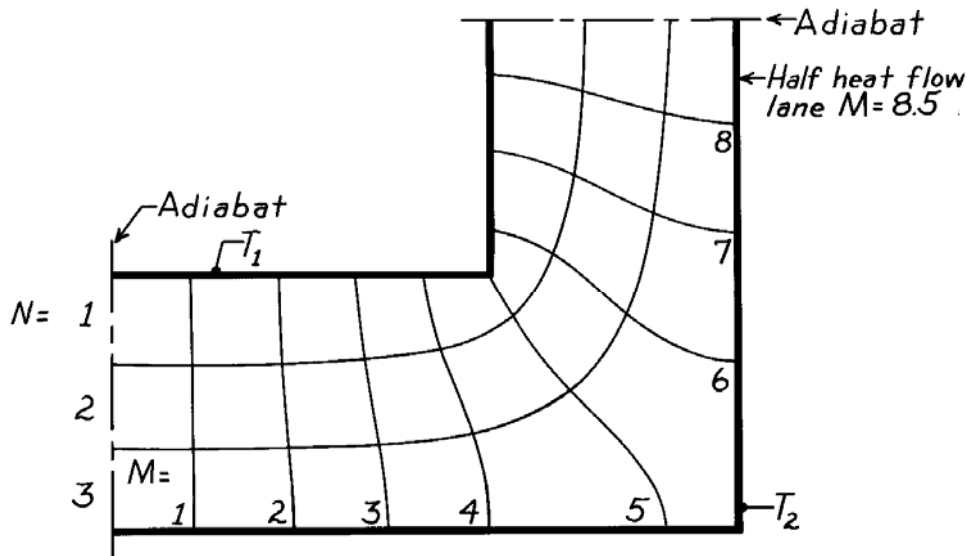

From Equation 4S.7,  $S = \frac{M\ell}{N}$  or  $\frac{S}{\ell} = \frac{M}{N} = \frac{8.5}{3} = 2.83$  <

and from Equation (1),  $q' = 4 \times 2.83 \times 1.2 \frac{\text{W}}{\text{m} \cdot \text{K}} (600 - 60)^\circ \text{C} = 7.34 \text{ kW/m}$ . <

**COMMENTS:** The shape factor can also be estimated from the relations of Table 4.1. The symmetrical section consists of two plane walls (horizontal and vertical) with an adjoining edge. Using the appropriate relations, the numerical values are, in the same order,

$$S = \frac{0.75\text{m}}{0.5\text{m}} \ell + 0.54\ell + \frac{0.5\text{m}}{0.5\text{m}} \ell = 3.04\ell$$

Note that this result compares favorably with the flux plot result of  $2.83\ell$ .

### PROBLEM 4S.2

**KNOWN:** Hot pipe embedded eccentrically in a circular system having a prescribed thermal conductivity.

**FIND:** The shape factor and heat transfer per unit length for the prescribed surface temperatures.

**SCHEMATIC:**

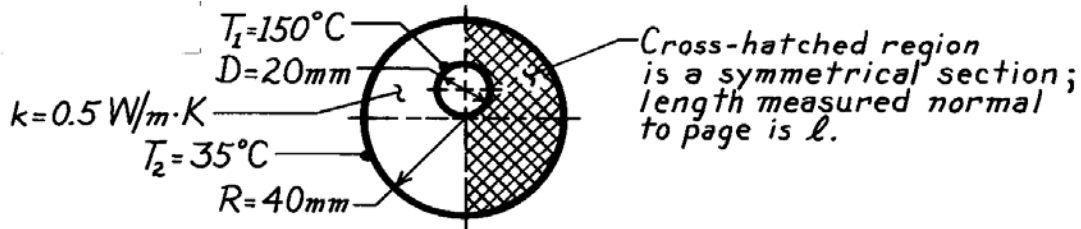

**ASSUMPTIONS:** (1) Two-dimensional conduction, (2) Steady-state conditions, (3) Length  $l \gg$  diametrical dimensions.

**ANALYSIS:** Considering the cross-sectional view of the pipe system, the symmetrical section shown above is readily identified. Selecting four temperature increments ( $N = 4$ ), construct the flux plot shown below.

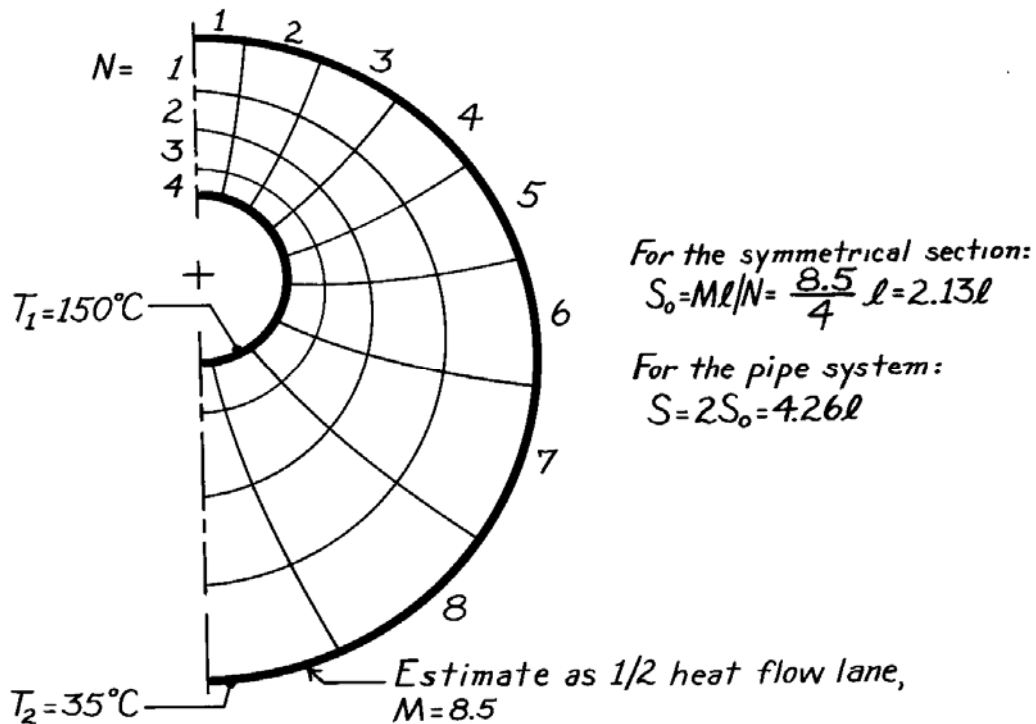

For the pipe system, the heat rate per unit length is

$$q' = \frac{q}{l} = kS(T_1 - T_2) = 0.5 \frac{\text{W}}{\text{m}\cdot\text{K}} \times 4.26(150 - 35)^\circ\text{C} = 245 \text{ W/m.} \quad <$$

**COMMENTS:** Note that in the lower, right-hand quadrant of the flux plot, the curvilinear squares are irregular. Further work is required to obtain an improved plot and, hence, obtain a more accurate estimate of the shape factor.

### PROBLEM 4S.3

**KNOWN:** Structural member with known thermal conductivity subjected to a temperature difference.

**FIND:** (a) Temperature at a prescribed point P, (b) Heat transfer per unit length of the strut, (c) Sketch the 25, 50 and 75°C isotherms, and (d) Same analysis on the shape but with adiabatic-isothermal boundary conditions reversed.

**SCHEMATIC:**

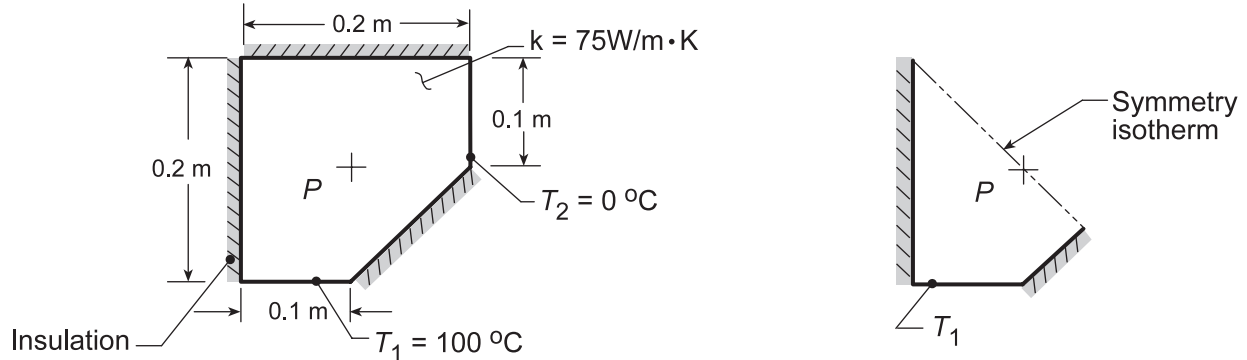

**ASSUMPTIONS:** (1) Two-dimensional conduction, (2) Steady-state conditions, (3) Constant properties.

**ANALYSIS:** (a) When constructing the flux plot, note that the line of symmetry which passes through the point P is an isotherm as shown above. It follows that

$$T(P) = (T_1 + T_2)/2 = (100 + 0)^\circ \text{C} / 2 = 50^\circ \text{C}. \quad \leftarrow$$

(b) The flux plot on the symmetrical section is now constructed to obtain the shape factor from which the heat rate is determined. That is, from Equation 4S.6 and 4S.7,

$$q = kS(T_1 - T_2) \quad \text{and} \quad S = M\ell/N. \quad (1,2)$$

From the plot of the symmetrical section,

$$S_0 = 4.2\ell/4 = 1.05\ell.$$

For the full section of the strut,

$$M = M_0 = 4.2$$

but  $N = 2N_0 = 8$ . Hence,

$$S = S_0/2 = 0.53\ell$$

and with  $q' = q/\ell$ , giving

$$q'/\ell = 75 \text{ W/m} \cdot \text{K} \times 0.53(100 - 0)^\circ \text{C} = 3975 \text{ W/m}. \quad \leftarrow$$

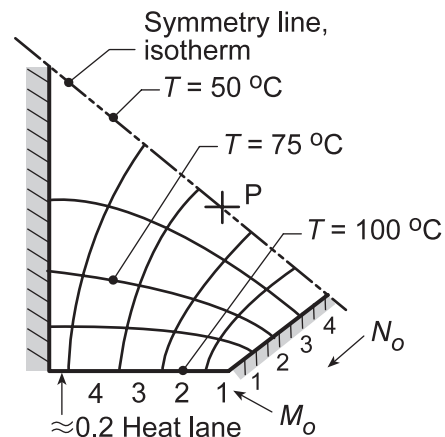

(c) The isotherms for  $T = 50, 75$  and  $100^\circ\text{C}$  are shown on the flux plot. The  $T = 25^\circ\text{C}$  isotherm is symmetric with the  $T = 75^\circ\text{C}$  isotherm.

(d) By reversing the adiabatic and isothermal boundary conditions, the two-dimensional shape appears as shown in the sketch below. The symmetrical element to be flux plotted is the same as for the strut, except the symmetry line is now an adiabat.

Continued...



**PROBLEM 4S.3 (Cont.)**

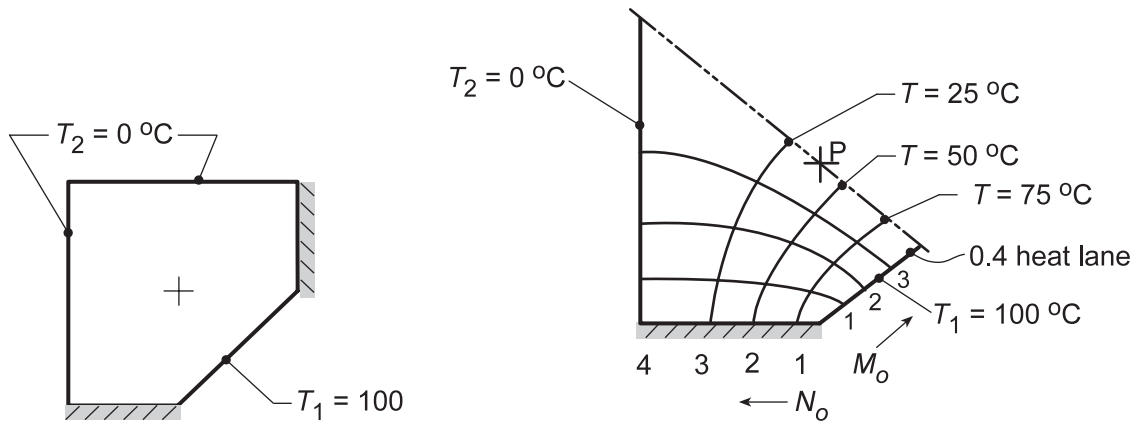

From the flux plot, find  $M_o = 3.4$  and  $N_o = 4$ , and from Equation (2)

$$S_o = M_o \ell / N_o = 3.4 \ell / 4 = 0.85 \ell \quad S = 2S_o = 1.70 \ell$$

and the heat rate per unit length from Equation (1) is

$$q' = 75 \text{ W/m} \cdot \text{K} \times 1.70 (100 - 0)^\circ \text{C} = 12,750 \text{ W/m} \quad <$$

From the flux plot, estimate that

$$T(P) \approx 40^\circ \text{C}. \quad <$$

**COMMENTS:** (1) By inspection of the shapes for parts (a) and (b), it is obvious that the heat rate for the latter will be greater. The calculations show the heat rate is greater by more than a factor of three.

(2) By comparing the flux plots for the two configurations, and corresponding roles of the adiabats and isotherms, would you expect the shape factor for parts (a) to be the reciprocal of part (b)?

**PROBLEM 4S.4**

**KNOWN:** Relative dimensions and surface thermal conditions of a V-grooved channel.

**FIND:** Flux plot and shape factor.

**SCHEMATIC:**

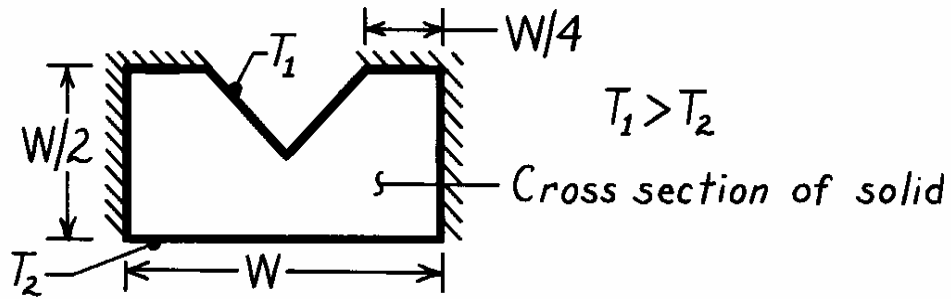

**ASSUMPTIONS:** (1) Two-dimensional conduction, (2) Steady-state conditions, (3) Constant properties.

**ANALYSIS:** With symmetry about the midplane, only one-half of the object need be considered as shown below.

Choosing 6 temperature increments ( $N = 6$ ), it follows from the plot that  $M \approx 7$ . Hence from Equation 4S.7, the shape factor for the half section is

$$S = \frac{M}{N} \ell = \frac{7}{6} \ell = 1.17\ell.$$

For the complete system, the shape factor is then

$$S = 2.34\ell.$$

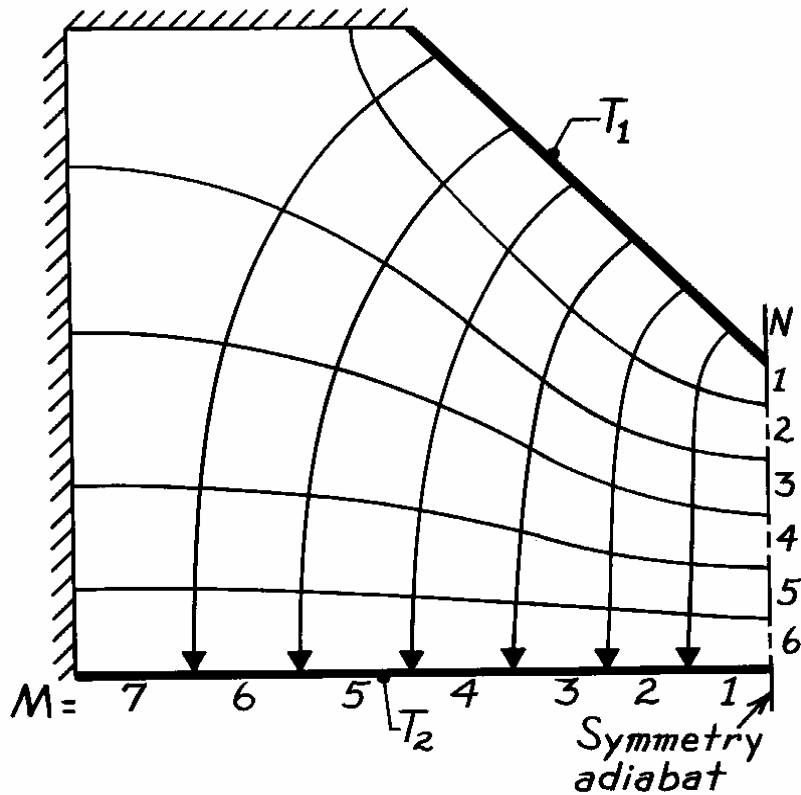

<

## PROBLEM 4S.5

**KNOWN:** Long conduit of inner circular cross section and outer surfaces of square cross section.

**FIND:** Shape factor and heat rate for the two applications when outer surfaces are insulated or maintained at a uniform temperature.

**SCHEMATIC:**

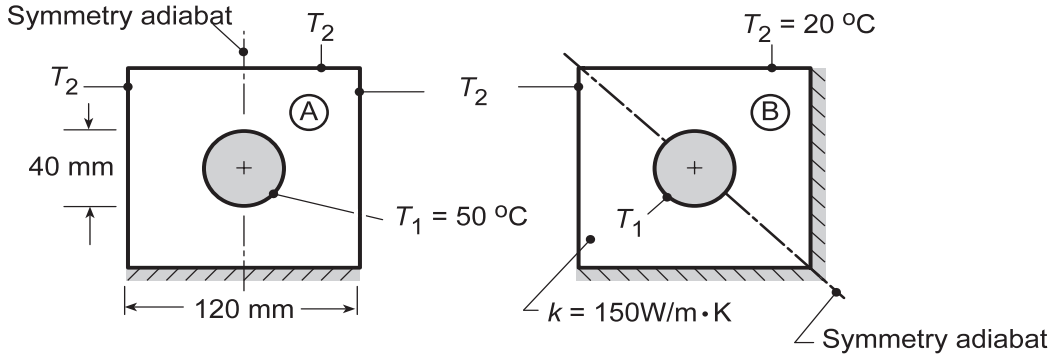

**ASSUMPTIONS:** (1) Two-dimensional, steady-state conduction, (2) Constant properties and (3) Conduit is very long.

**ANALYSIS:** The adiabatic symmetry lines for each of the applications is shown above. Using the flux plot methodology and selecting four temperature increments ( $N = 4$ ), the flux plots are as shown below.

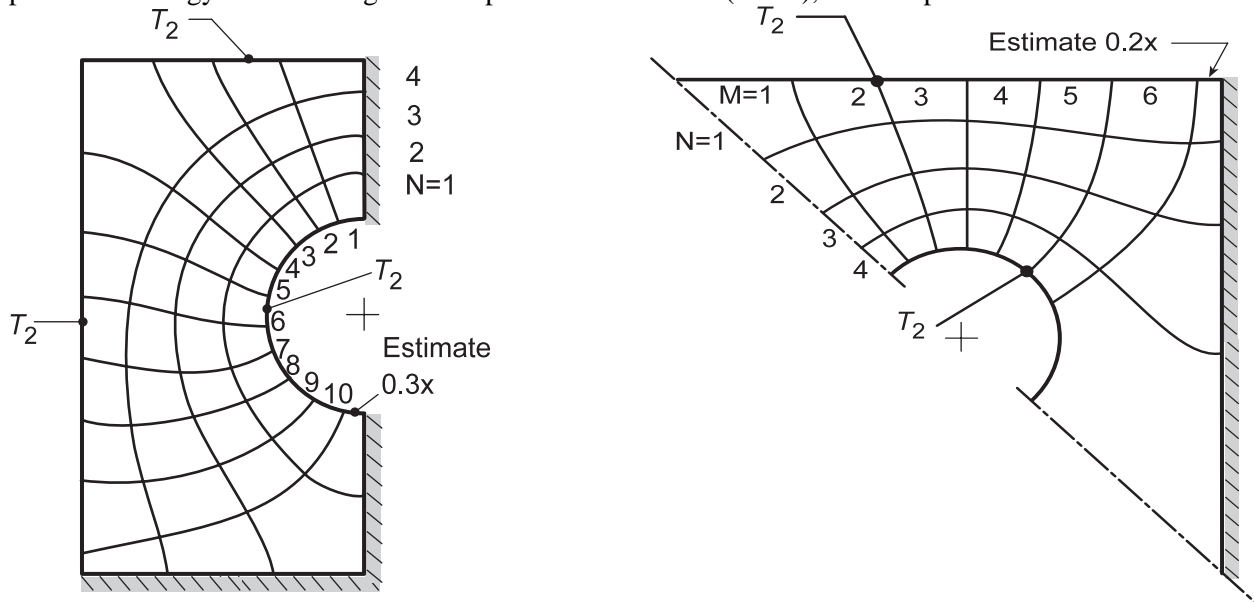

For the symmetrical sections,  $S = 2S_o$ , where  $S_o = M \ell / N$  and the heat rate for each application is  $q = 2(S_o / \ell)k(T_1 - T_2)$ .

Application	M	N	$S_o / \ell$	$q'$ (W/m)	
A	10.3	4	2.58	11,588	<
B	6.2	4	1.55	6,975	<

**COMMENTS:** (1) For application A, most of the heat lanes leave the inner surface ( $T_1$ ) on the upper portion.

(2) For application B, most of the heat flow lanes leave the inner surface on the upper portion (that is, lanes 1-4). Because the lower, right-hand corner is insulated, the entire section experiences small heat flows (lane 6 + 0.2). Note the shapes of the isotherms near the right-hand, insulated boundary and that they intersect the boundary normally.

### PROBLEM 4S.6

**KNOWN:** Shape and surface conditions of a support column.

**FIND:** (a) Heat transfer rate per unit length. (b) Height of a rectangular bar of equivalent thermal resistance.

**SCHEMATIC:**

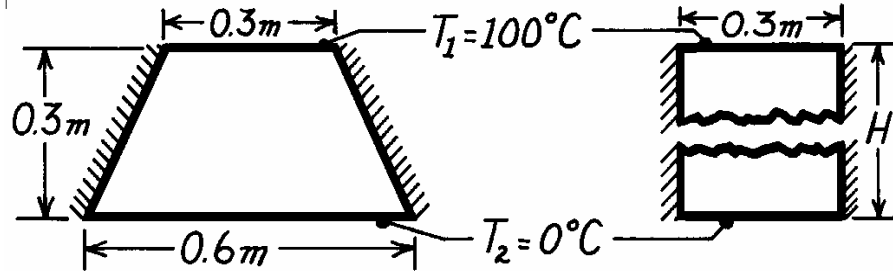

**ASSUMPTIONS:** (1) Steady-state conditions, (2) Negligible three-dimensional conduction effects, (3) Constant properties, (4) Adiabatic sides.

**PROPERTIES:** Table A-1, Steel, AISI 1010 (323K):  $k = 62.7 \text{ W/m}\cdot\text{K}$ .

**ANALYSIS:** (a) From the flux plot for the half section,  $M \approx 5$  and  $N \approx 8$ . Hence for the full section

$$S = 2 \frac{M\ell}{N} \approx 1.25\ell$$

$$q = Sk(T_1 - T_2)$$

$$q' \approx 1.25 \times 62.7 \frac{\text{W}}{\text{m}\cdot\text{K}} (100 - 0)^\circ\text{C}$$

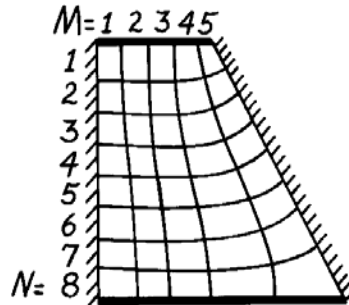

$$q' \approx 7.8 \text{ kW/m.} \quad <$$

(b) The rectangular bar provides for one-dimensional heat transfer. Hence,

$$q = k A \frac{(T_1 - T_2)}{H} = k(0.3\ell) \frac{(T_1 - T_2)}{H}$$

Hence, 
$$H = \frac{0.3k(T_1 - T_2)}{q'} = \frac{0.3\text{m}(62.7 \text{ W/m}\cdot\text{K})(100^\circ\text{C})}{7800 \text{ W/m}} = 0.24\text{m.} \quad <$$

**COMMENTS:** The fact that  $H < 0.3\text{m}$  is consistent with the requirement that the thermal resistance of the trapezoidal column must be less than that of a rectangular bar of the same height and top width (because the width of the trapezoidal column increases with increasing distance,  $x$ , from the top). Hence, if the rectangular bar is to be of equivalent resistance, it must be of smaller height.

### PROBLEM 4S.7

**KNOWN:** Hollow prismatic bars fabricated from plain carbon steel, 1m in length with prescribed temperature difference.

**FIND:** Shape factors and heat rate per unit length.

**SCHEMATIC:**

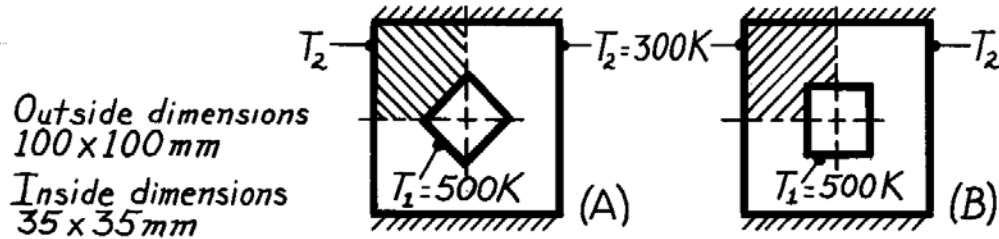

**ASSUMPTIONS:** (1) Steady-state conditions, (2) Two-dimensional conduction, (3) Constant properties.

**PROPERTIES:** Table A-1, Steel, Plain Carbon (400K),  $k = 57 \text{ W/m}\cdot\text{K}$ .

**ANALYSIS:** Construct a flux plot on the symmetrical sections (shaded-regions) of each of the bars.

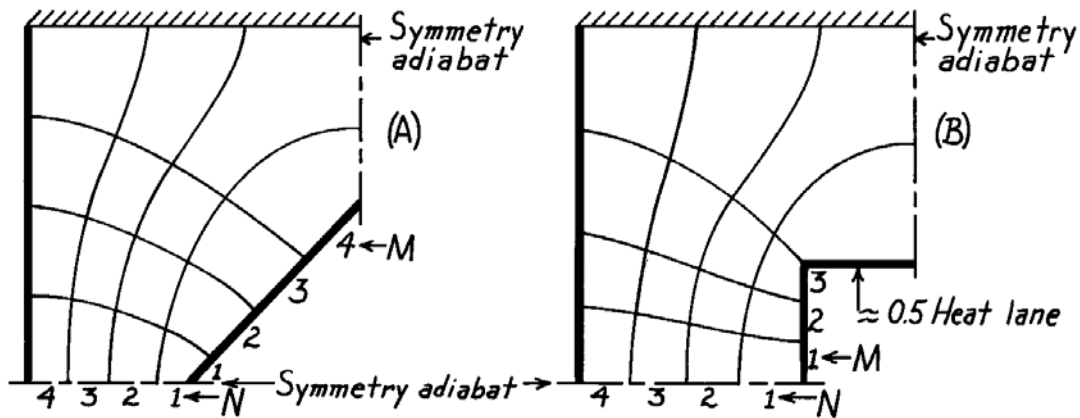

The shape factors for the symmetrical sections are,

$$S_{o,A} = \frac{M\ell}{N} = \frac{4}{4}\ell = 1\ell \quad S_{o,B} = \frac{M\ell}{N} = \frac{3.5}{4}\ell = 0.88\ell.$$

Since each of these sections is  $\frac{1}{4}$  of the bar cross-section, it follows that

$$S_A = 4 \times 1\ell = 4\ell \quad S_B = 4 \times 0.88\ell = 3.5\ell. \quad <$$

The heat rate per unit length is  $q' = q/\ell = k(S/\ell)(T_1 - T_2)$ ,

$$q'_A = 57 \frac{\text{W}}{\text{m}\cdot\text{K}} \times 4(500 - 300) \text{ K} = 45.6 \text{ kW/m} \quad <$$

$$q'_B = 57 \frac{\text{W}}{\text{m}\cdot\text{K}} \times 3.5(500 - 300) \text{ K} = 39.9 \text{ kW/m}. \quad <$$

## PROBLEM 4S.8

**KNOWN:** Two-dimensional, square shapes, 1 m to a side, maintained at uniform temperatures as prescribed, perfectly insulated elsewhere.

**FIND:** Using the flux plot method, estimate the heat rate per unit length normal to the page if the thermal conductivity is 50 W/m·K

**ASSUMPTIONS:** (1) Steady-state, two-dimensional conduction, (2) Constant properties.

**ANALYSIS:** Use the methodology of Section 4S.1 to construct the flux plots to obtain the shape factors from which the heat rates can be calculated. With Figure (a), begin at the lower-left side making the isotherms almost equally spaced, since the heat flow will only slightly spread toward the right. Start sketching the adiabats in the vicinity of the  $T_2$  surface. The dashed line represents the adiabat which separates the shape into two segments. Having recognized this feature, it was convenient to identify partial heat lanes. Figure (b) is less difficult to analyze since the isotherm intervals are nearly regular in the lower left-hand corner.

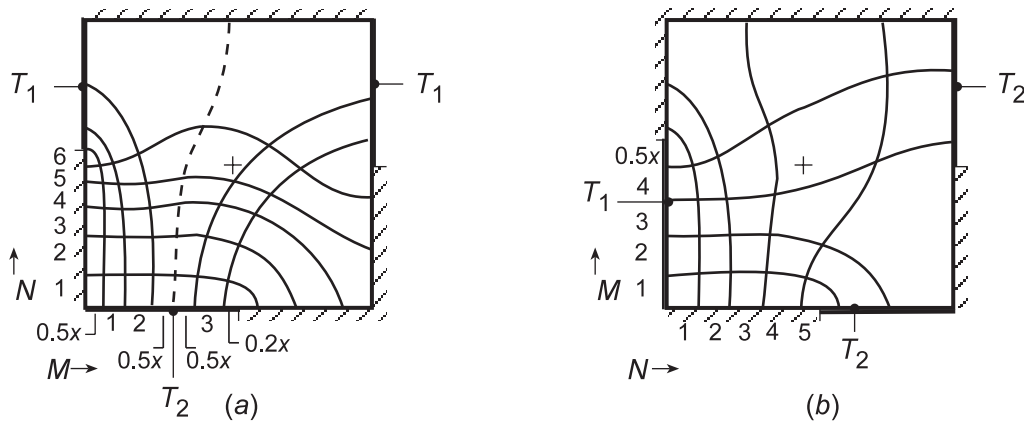

The shape factors are calculated from Equation 4S.7 and the heat rate from Equation 4S.6.

$$S' = \frac{M}{N} = \frac{0.5 + 3 + 0.5 + 0.5 + 0.2}{6}$$

$$S' = \frac{M}{N} = \frac{4.5}{5} = 0.90$$

$$S' = 0.70$$

$$q' = kS'(T_1 - T_2)$$

$$q' = kS'(T_1 - T_2)$$

$$q' = 50 \text{ W/m} \cdot \text{K} \times 0.70(100 - 0) \text{ K} = 3500 \text{ W/m} \quad q' = 50 \text{ W/m} \cdot \text{K} \times 0.90(100 - 0) \text{ K} = 4500 \text{ W/m} \quad <$$

**COMMENTS:** Using a finite-element package with a fine mesh, we determined heat rates of 4780 and 4575 W/m, respectively, for Figures (a) and (b). The estimate for the less difficult Figure (b) is within 2% of the numerical method result. For Figure (a), our flux plot result was 27% low.

### PROBLEM 5S.1

**KNOWN:** Configuration, initial temperature and charging conditions of a thermal energy storage unit.

**FIND:** Time required to achieve 75% of maximum possible energy storage and corresponding minimum and maximum temperatures.

**SCHEMATIC:**

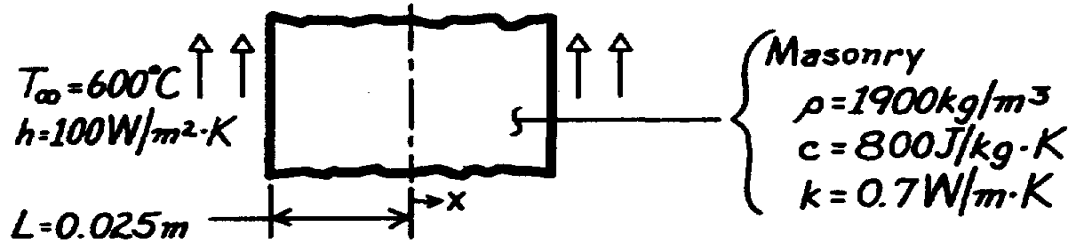

**ASSUMPTIONS:** (1) One-dimensional conduction, (2) Constant properties, (3) Negligible radiation exchange with surroundings.

**ANALYSIS:** For the system, find first

$$Bi = \frac{hL}{k} = \frac{100 \text{ W/m}^2 \cdot \text{K} \times 0.025 \text{ m}}{0.7 \text{ W/m} \cdot \text{K}} = 3.57$$

indicating that the lumped capacitance method cannot be used.

*Groeber chart, Fig. 5S.3:*  $Q/Q_o = 0.75$

$$\alpha = \frac{k}{\rho c} = \frac{0.7 \text{ W/m} \cdot \text{K}}{1900 \text{ kg/m}^3 \times 800 \text{ J/kg} \cdot \text{K}} = 4.605 \times 10^{-7} \text{ m}^2/\text{s}$$

$$Bi^2 Fo = \frac{h^2 \alpha t}{k^2} = \frac{(100 \text{ W/m}^2 \cdot \text{K})^2 \times (4.605 \times 10^{-7} \text{ m}^2/\text{s}) \times t(\text{s})}{(0.7 \text{ W/m} \cdot \text{K})^2} = 9.4 \times 10^{-3} t$$

Find  $Bi^2 Fo \approx 11$ , and substituting numerical values

$$t = 11/9.4 \times 10^{-3} = 1170 \text{ s.} \quad <$$

*Heisler chart, Fig. 5S.1:*  $T_{\min}$  is at  $x = 0$  and  $T_{\max}$  at  $x = L$ , with

$$Fo = \frac{\alpha t}{L^2} = \frac{4.605 \times 10^{-7} \text{ m}^2/\text{s} \times 1170 \text{ s}}{(0.025 \text{ m})^2} = 0.86 \quad Bi^{-1} = 0.28.$$

From Fig. 5S.1,  $\theta_o^* \approx 0.33$ . Hence,

$$T_o \approx T_{\infty} + 0.33(T_i - T_{\infty}) = 600^\circ \text{C} + 0.33(-575^\circ \text{C}) = 410^\circ \text{C} = T_{\min}. \quad <$$

From Fig. 5S.2,  $\theta/\theta_o \approx 0.33$  at  $x = L$ , for which

$$T_{x=L} \approx T_{\infty} + 0.33(T_o - T_{\infty}) = 600^\circ \text{C} + 0.33(-190)^\circ \text{C} = 537^\circ \text{C} = T_{\max}. \quad <$$

**COMMENTS:** Comparing masonry (m) with aluminum (Al), see Problem 5.16,  $(\rho c)_{Al} > (\rho c)_m$  and  $k_{Al} > k_m$ . Hence, the aluminum can store more energy and can be charged (or discharged) more quickly.

## PROBLEM 5S.2

**KNOWN:** Car windshield, initially at a uniform temperature of  $-20^{\circ}\text{C}$ , is suddenly exposed on its interior surface to the defrost system airstream at  $30^{\circ}\text{C}$ . The ice layer on the exterior surface acts as an insulating layer.

**FIND:** What airstream convection coefficient would allow the exterior surface to reach  $0^{\circ}\text{C}$  in 60 s?

**SCHEMATIC:**

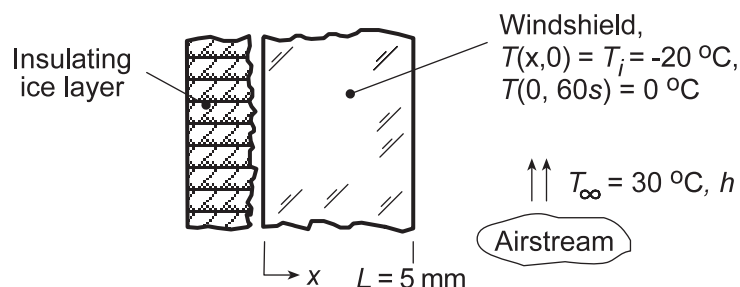

**ASSUMPTIONS:** (1) One-dimensional, transient conduction in the windshield, (2) Constant properties, (3) Exterior surface is perfectly insulated.

**PROPERTIES:** Windshield (Given):  $\rho = 2200\text{ kg/m}^3$ ,  $c_p = 830\text{ J/kg}\cdot\text{K}$  and  $k = 1.2\text{ W/m}\cdot\text{K}$ .

**ANALYSIS:** For the prescribed conditions, from Equations 5.34 and 5.36,

$$\frac{\theta(0, 60\text{s})}{\theta_i} = \frac{\theta_o}{\theta_i} = \frac{T(0, 60\text{s}) - T_{\infty}}{T_i - T_{\infty}} = \frac{(0 - 30)^{\circ}\text{C}}{(-20 - 30)^{\circ}\text{C}} = 0.6$$

$$Fo = \frac{kt}{\rho cL^2} = \frac{1.2\text{ W/m}\cdot\text{K} \times 60}{2200\text{ kg/m}^3 \times 830\text{ J/kg}\cdot\text{K} \times (0.005\text{ m})^2} = 1.58$$

The single-term series approximation, Eq. 5.44, along with Table 5.1, requires an iterative solution to find an appropriate Biot number. Alternatively, the Heisler charts, Section 5S.1, Figure 5S.1, for the midplane temperature could be used to find

$$Bi^{-1} = k/hL = 2.5$$

$$h = 1.2\text{ W/m}\cdot\text{K} / 2.5 \times 0.005\text{ m} = 96\text{ W/m}^2\cdot\text{K} \quad <$$

**COMMENTS:** Using the *IHT, Transient Conduction, Plane Wall Model*, the convection coefficient can be determined by solving the model with an assumed  $h$  and then sweeping over a range of  $h$  until the  $T(0, 60\text{s})$  condition is satisfied. Since the model is based upon multiple terms of the series, the result of  $h = 99\text{ W/m}^2\cdot\text{K}$  is more precise than that found using the chart.



### PROBLEM 5S.3

**KNOWN:** Inlet and outlet temperatures of steel rods heat treated by passage through an oven.

**FIND:** Rod speed,  $V$ .

**SCHEMATIC:**

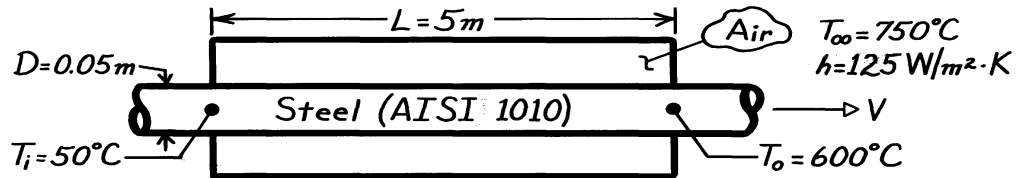

**ASSUMPTIONS:** (1) One-dimensional radial conduction (axial conduction is negligible), (2) Constant properties, (3) Negligible radiation.

**PROPERTIES:** Table A-1, AISI 1010 Steel ( $\bar{T} \approx 600\text{K}$ ):  $k = 48.8 \text{ W/m}\cdot\text{K}$ ,  $\rho = 7832 \text{ kg/m}^3$ ,  $c_p = 559 \text{ J/kg}\cdot\text{K}$ ,  $\alpha = (k/\rho c_p) = 1.11 \times 10^{-5} \text{ m}^2/\text{s}$ .

**ANALYSIS:** The time needed to traverse the rod through the oven may be found from Figure 5S.4.

$$\theta_o^* = \frac{T_o - T_\infty}{T_i - T_\infty} = \frac{600 - 750}{50 - 750} = 0.214$$

$$\text{Bi}^{-1} = \frac{k}{h r_o} = \frac{48.8 \text{ W/m}\cdot\text{K}}{125 \text{ W/m}^2\cdot\text{K} (0.025\text{m})} = 15.6.$$

Hence,

$$\text{Fo} = \alpha t/r_o^2 \approx 12.2$$

$$t = 12.2(0.025\text{m})^2 / 1.11 \times 10^{-5} \text{ m}^2/\text{s} = 687 \text{ s}.$$

The rod velocity is

$$V = \frac{L}{t} = \frac{5\text{m}}{687\text{s}} = 0.0073 \text{ m/s}.$$

**COMMENTS:** (1) Since  $(h r_o/2)/k = 0.032$ , the lumped capacitance method could have been used. From Equation 5.5 it follows that  $t = 675 \text{ s}$ .

(2) Radiation effects decrease  $t$  and hence increase  $V$ , assuming there is net radiant transfer from the oven walls to the rod.

(3) Since  $\text{Fo} > 0.2$ , the approximate analytical solution may be used. With  $\text{Bi} = h r_o/k = 0.0641$ , Table 5.1 yields  $\zeta_1 = 0.3549 \text{ rad}$  and  $C_1 = 1.0158$ . Hence from Equation 5.52c

$$\text{Fo} = -\left(\zeta_1^2\right)^{-1} \ln \left[ \frac{\theta_o^*}{C_1} \right] = 12.4,$$

which is in good agreement with the graphical result.

### PROBLEM 5S.4

**KNOWN:** Hot dog with prescribed thermophysical properties, initially at  $6^\circ\text{C}$ , is immersed in boiling water.

**FIND:** Time required to bring centerline temperature to  $80^\circ\text{C}$ .

**SCHEMATIC:**

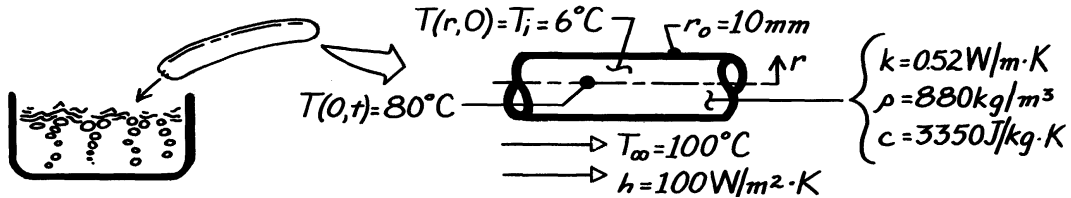

**ASSUMPTIONS:** (1) Hot dog can be treated as infinite cylinder, (2) Constant properties.

**ANALYSIS:** The Biot number, based upon Equation 5.10, is

$$\text{Bi} \equiv \frac{h L_c}{k} = \frac{h r_o / 2}{k} = \frac{100 \text{ W/m}^2 \cdot \text{K} (10 \times 10^{-3} \text{ m} / 2)}{0.52 \text{ W/m} \cdot \text{K}} = 0.96$$

Since  $\text{Bi} > 0.1$ , a lumped capacitance analysis is not appropriate. Using the Heisler chart, Figure 5S.4 with

$$\text{Bi} \equiv \frac{h r_o}{k} = \frac{100 \text{ W/m}^2 \cdot \text{K} \times 10 \times 10^{-3} \text{ m}}{0.52 \text{ W/m} \cdot \text{K}} = 1.92 \quad \text{or} \quad \text{Bi}^{-1} = 0.52$$

and 
$$\theta_o^* = \frac{\theta_o}{\theta_i} = \frac{T(0, t) - T_\infty}{T_i - T_\infty} = \frac{(80 - 100)^\circ\text{C}}{(6 - 100)^\circ\text{C}} = 0.21 \quad (1)$$

find 
$$\text{Fo} = t^* = \frac{\alpha t}{r_o^2} = 0.8 \quad t = \frac{r_o^2}{\alpha} \cdot \text{Fo} = \frac{(10 \times 10^{-3} \text{ m})^2}{1.764 \times 10^{-7} \text{ m}^2/\text{s}} \times 0.8 = 453.5 \text{ s} = 7.6 \text{ min} <$$

where 
$$\alpha = k / \rho c = 0.52 \text{ W/m} \cdot \text{K} / 880 \text{ kg/m}^3 \times 3350 \text{ J/kg} \cdot \text{K} = 1.764 \times 10^{-7} \text{ m}^2/\text{s}.$$

**COMMENTS:** (1) Note that  $L_c = r_o/2$  when evaluating the Biot number for the lumped capacitance analysis; however, in the Heisler charts,  $\text{Bi} \equiv h r_o/k$ .

(2) The surface temperature of the hot dog follows from use of Figure 5S.5 with  $r/r_o = 1$  and  $\text{Bi}^{-1} = 0.52$ ; find  $\theta(1, t)/\theta_o \approx 0.45$ . From Equation (1), note that  $\theta_o = 0.21 \theta_i$  giving

$$\theta(1, t) = T(r_o, t) - T_\infty = 0.45 \theta_o = 0.45 (0.21 [T_i - T_\infty]) = 0.45 \times 0.21 [6 - 100]^\circ\text{C} = -8.9^\circ\text{C}$$

$$T(r_o, t) = T_\infty - 8.9^\circ\text{C} = (100 - 8.9)^\circ\text{C} = 91.1^\circ\text{C}$$

(3) Since  $\text{Fo} \geq 0.2$ , the approximate solution for  $\theta^*$ , Equation 5.52, is valid. From Table 5.1 with  $\text{Bi} = 1.92$ , find that  $\zeta_1 = 1.3245$  rad and  $C_1 = 1.2334$ . Rearranging Equation 5.52 and substituting values,

$$\text{Fo} = -\frac{1}{\zeta_1^2} \ln \left( \theta_o^* / C_1 \right) = \frac{1}{(1.3245 \text{ rad})^2} \ln \left[ \frac{0.213}{1.2334} \right] = 1.00$$

This result leads to a value of  $t = 9.5$  min or 20% higher than that of the graphical method.

### PROBLEM 5S.5

**KNOWN:** Long bar of 70 mm diameter, initially at 90°C, is suddenly immersed in a water bath ( $T_\infty = 40^\circ\text{C}$ ,  $h = 20 \text{ W/m}^2\cdot\text{K}$ ).

**FIND:** (a) Time,  $t_f$ , that bar should remain in bath in order that, when removed and allowed to equilibrate while isolated from surroundings, it will have a uniform temperature  $T(r, \infty) = 55^\circ\text{C}$ .

**SCHEMATIC:**

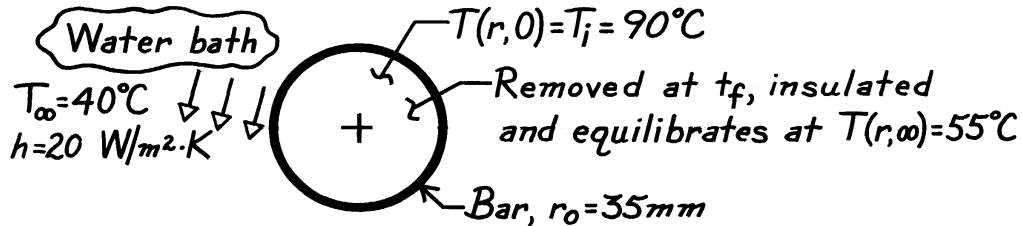

**ASSUMPTIONS:** (1) One-dimensional radial conduction, (2) Constant properties.

**PROPERTIES:** Bar (given):  $\rho = 2600 \text{ kg/m}^3$ ,  $c = 1030 \text{ J/kg}\cdot\text{K}$ ,  $k = 3.50 \text{ W/m}\cdot\text{K}$ ,  $\alpha = k/\rho c = 1.31 \times 10^{-6} \text{ m}^2/\text{s}$ .

**ANALYSIS:** Determine first whether conditions are space-wise isothermal

$$\text{Bi} = \frac{hL_c}{k} = \frac{h(r_o/2)}{k} = \frac{20 \text{ W/m}^2\cdot\text{K} \cdot (0.035 \text{ m}/2)}{3.50 \text{ W/m}\cdot\text{K}} = 0.10$$

and since  $\text{Bi} \geq 0.1$ , a Heisler solution is appropriate.

(a) Consider an overall energy balance on the bar during the time interval  $\Delta t = t_f$  (the time the bar is in the bath).

$$E_{\text{in}} - E_{\text{out}} = \Delta E$$

$$0 - Q = E_{\text{final}} - E_{\text{initial}} = Mc(T_f - T_\infty) - Mc(T_i - T_\infty)$$

$$-Q = Mc(T_f - T_\infty) - Q_o$$

$$\frac{Q}{Q_o} = 1 - \frac{T_f - T_\infty}{T_i - T_\infty} = 1 - \frac{(55 - 40)^\circ\text{C}}{(90 - 40)^\circ\text{C}} = 0.70$$

where  $Q_o$  is the initial energy in the bar (relative to  $T_\infty$ ; Equation 5.44). With  $\text{Bi} = hr_o/k = 0.20$  and  $Q/Q_o = 0.70$ , use Figure 5S.6 to find  $\text{Bi}^2\text{Fo} = 0.15$ ; hence  $\text{Fo} = 0.15/\text{Bi}^2 = 3.75$  and

$$t_f = \text{Fo} \cdot r_o^2 / \alpha = 3.75 (0.035 \text{ m})^2 / 1.31 \times 10^{-6} \text{ m}^2/\text{s} = 3507 \text{ s.} \quad <$$

(b) To determine  $T(r_o, t_f)$ , use Figures 5S.4 and 5S.5 for  $\theta(r_o, t)/\theta_i$  ( $\text{Fo} = 3.75$ ,  $\text{Bi}^{-1} = 5.0$ ) and  $\theta_o/\theta_i$  ( $\text{Bi}^{-1} = 5.0$ ,  $r/r_o = 1$ , respectively, to find

$$T(r_o, t_f) = T_\infty + \frac{\theta(r_o, t)}{\theta_o} \cdot \frac{\theta_o}{\theta_i} \cdot \theta_i = 40^\circ\text{C} + 0.25 \times 0.90 (90 - 40)^\circ\text{C} = 51^\circ\text{C.} \quad <$$

### PROBLEM 5S.6

**KNOWN:** An 80 mm sphere, initially at a uniform elevated temperature, is quenched in an oil bath with prescribed  $T_\infty$ ,  $h$ .

**FIND:** The center temperature of the sphere,  $T(0,t)$  at a certain time when the surface temperature is  $T(r_o,t) = 150^\circ\text{C}$ .

**SCHEMATIC:**

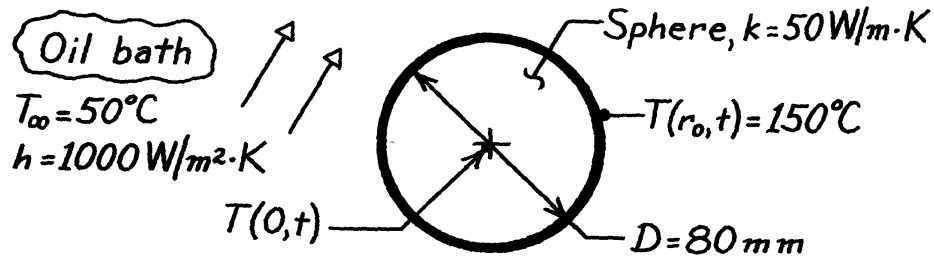

**ASSUMPTIONS:** (1) One-dimensional radial conduction, (2) Initial uniform temperature within sphere, (3) Constant properties, (4)  $Fo \geq 0.2$ .

**ANALYSIS:** Check first to see if the sphere is spacewise isothermal.

$$Bi_c = \frac{hL_c}{k} = \frac{h(r_o/3)}{k} = \frac{1000 \text{ W/m}^2 \cdot \text{K} \times 0.040 \text{ m}/3}{50 \text{ W/m} \cdot \text{K}} = 0.26.$$

Since  $Bi_c > 0.1$ , lumped capacitance method is not appropriate. Recognize that when  $Fo \geq 0.2$ , the time dependence of the temperature at any point within the sphere will be the same as the center. Using the Heisler chart method, Figure 5S.8 provides the relation between  $T(r_o, t)$  and  $T(0, t)$ . Find first the Biot number,

$$Bi = \frac{hr_o}{k} = \frac{1000 \text{ W/m}^2 \cdot \text{K} \times 0.040 \text{ m}}{50 \text{ W/m} \cdot \text{K}} = 0.80.$$

With  $Bi^{-1} = 1/0.80 = 1.25$  and  $r/r_o = 1$ , read from Figure 5S.8,

$$\frac{\theta}{\theta_o} = \frac{T(r_o, t) - T_\infty}{T(0, t) - T_\infty} = 0.67.$$

It follows that

$$T(0, t) = T_\infty + \frac{1}{0.67} [T(r_o, t) - T_\infty] = 50^\circ\text{C} + \frac{1}{0.67} [150 - 50]^\circ\text{C} = 199^\circ\text{C}. \quad <$$

**COMMENTS:** (1) There is sufficient information to evaluate  $Fo$ ; hence, we require that the time be sufficiently long after the start of quenching for this solution to be appropriate.

(2) The approximate series solution could also be used to obtain  $T(0, t)$ . For  $Bi = 0.80$  from Table 5.1,  $\zeta_1 = 1.5044$  rad. Substituting numerical values,  $r^* = 1$ ,

$$\frac{\theta^*}{\theta_o^*} = \frac{T(r_o, t) - T_\infty}{T(0, t) - T_\infty} = \frac{1}{\zeta_1 r^*} \sin(\zeta_1 r^*) = \frac{1}{1.5044} \sin(1.5044 \text{ rad}) = 0.663.$$

It follows that  $T(0, t) = 201^\circ\text{C}$ .

**PROBLEM 5S.7**

**KNOWN:** Diameter and initial temperature of hailstone falling through warm air.

**FIND:** (a) Time,  $t_m$ , required for outer surface to reach melting point,  $T(r_o, t_m) = T_m = 0^\circ\text{C}$ ,  
 (b) Centerpoint temperature at that time, (c) Energy transferred to the stone.

**SCHEMATIC:**

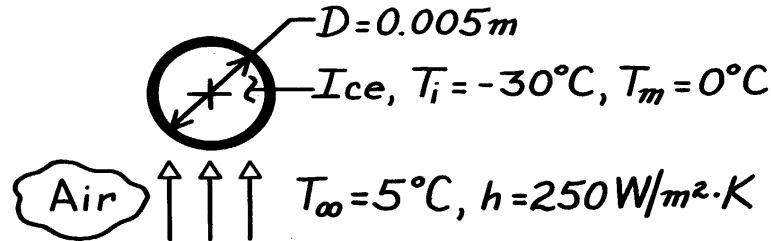

**ASSUMPTIONS:** (1) One-dimensional radial conduction, (2) Constant properties.

**PROPERTIES:** Table A-3, Ice (253K):  $\rho = 920 \text{ kg/m}^3$ ,  $k = 2.03 \text{ W/m}\cdot\text{K}$ ,  $c_p = 1945 \text{ J/kg}\cdot\text{K}$ ;  
 $\alpha = k/\rho c_p = 1.13 \times 10^{-6} \text{ m}^2/\text{s}$ .

**ANALYSIS:** (a) Calculate the lumped capacitance Biot number,

$$Bi = \frac{h(r_o/3)}{k} = \frac{250 \text{ W/m}^2 \cdot \text{K} (0.0025\text{m}/3)}{2.03 \text{ W/m}\cdot\text{K}} = 0.103.$$

Since  $Bi > 0.1$ , use the Heisler charts for which

$$\frac{\theta(r_o, t_m)}{\theta_i} = \frac{T(r_o, t_m) - T_\infty}{T_i - T_\infty} = \frac{0 - 5}{-30 - 5} = 0.143$$

$$Bi^{-1} = \frac{k}{hr_o} = \frac{2.03 \text{ W/m}\cdot\text{K}}{250 \text{ W/m}^2 \cdot \text{K} \times 0.0025\text{m}} = 3.25.$$

From Figure 5S.8, find  $\frac{\theta(r_o, t_m)}{\theta_o(t_m)} \approx 0.86$ .

It follows that  $\frac{\theta_o(t_m)}{\theta_i} = \frac{\theta(r_o, t_m)/\theta_i}{\theta(r_o, t_m)/\theta_o(t_m)} \approx \frac{0.143}{0.86} \approx 0.17$ .

From Figure 5S.7 find  $Fo \approx 2.1$ . Hence,

$$t_m \approx \frac{Fo r_o^2}{\alpha} = \frac{2.1(0.0025)^2}{1.13 \times 10^{-6} \text{ m}^2/\text{s}} = 12\text{s}. \quad <$$

(b) Since  $(\theta_o/\theta_i) \approx 0.17$ , find

$$T_o - T_\infty \approx 0.17(T_i - T_\infty) \approx 0.17(-30 - 5) \approx -6.0^\circ\text{C}$$

$$T_o(t_m) \approx -1.0^\circ\text{C}. \quad <$$

(c) With  $Bi^2 Fo = (1/3.25)^2 \times 2.1 = 0.2$ , from Figure 5S.9, find  $Q/Q_o \approx 0.82$ . From Equation 5.47,

$$Q_o = \rho V c_p \theta_i = (920 \text{ kg/m}^3) (\pi/6)(0.005\text{m})^3 1945 (\text{J/kg}\cdot\text{K})(-35\text{K}) = -4.10 \text{ J}$$

$$Q = 0.82 Q_o = 0.82(-4.10 \text{ J}) = -3.4 \text{ J}. \quad <$$

## PROBLEM 5S.8

**KNOWN:** Properties, initial temperature, and convection conditions associated with cooling of glass beads.

**FIND:** (a) Time required to achieve a prescribed center temperature, (b) Effect of convection coefficient on center and surface temperature histories.

**SCHEMATIC:**

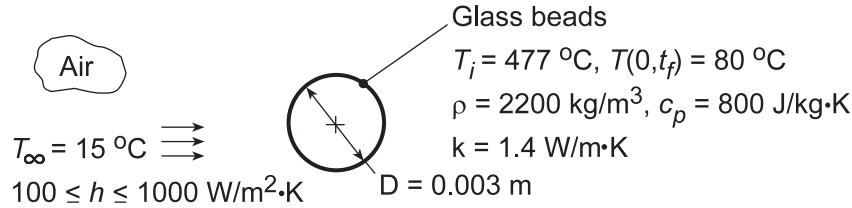

**ASSUMPTIONS:** (1) One-dimensional conduction in  $r$ , (2) Constant properties, (3) Negligible radiation, (4)  $Fo \geq 0.2$ .

**ANALYSIS:** (a) With  $h = 400\text{ W/m}^2\cdot\text{K}$ ,  $Bi \equiv h(r_o/3)/k = 400\text{ W/m}^2\cdot\text{K}(0.0005\text{ m})/1.4\text{ W/m}\cdot\text{K} = 0.143$  and the lumped capacitance method should not be used. Instead, use the Heisler charts for which

$$\theta_o = \frac{T(0, t) - T_\infty}{T_i - T_\infty} = \frac{80 - 15}{477 - 15} = 0.141$$

$$Bi^{-1} = \frac{k}{hr_o} = \frac{1.4\text{ W/m}\cdot\text{K}}{400\text{ W/m}^2\cdot\text{K} \times 0.0015\text{ m}} = 2.33.$$

From Figure 5S.7, find  $Fo \approx 1.8$ .

$$t \approx \frac{Fo r_o^2}{\alpha} = \frac{1.8(0.0015)^2}{\left[ 1.4\text{ W/m}\cdot\text{K} / (2200\text{ kg/m}^3 \times 800\text{ J/kg}\cdot\text{K}) \right]} = 5.1\text{ s.} \quad \leftarrow$$

From Figure 5S.8,  $\frac{\theta(r_o, t)}{\theta_o} \approx 0.82$ .

Hence, the corresponding surface temperature is

$$T(r_o, t) \approx T_\infty + 0.82(T_o - T_\infty) = 15\text{ }^\circ\text{C} + 0.82(80\text{ }^\circ\text{C} - 15\text{ }^\circ\text{C}) = 68.3\text{ }^\circ\text{C} \quad \leftarrow$$

(b) The effect of  $h$  on the surface and center temperatures was determined using the IHT *Transient Conduction Model* for a *Sphere*.

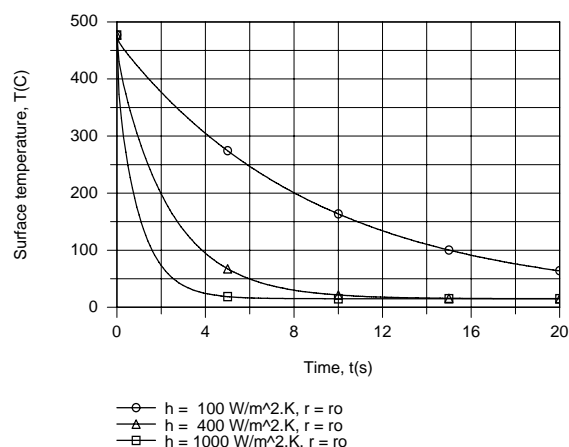
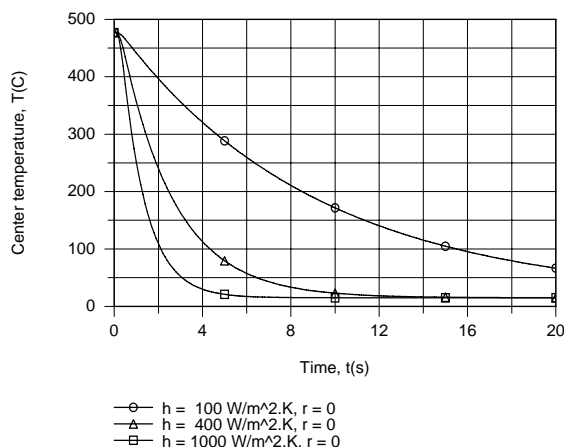

Continued...

### PROBLEM 5S.8 (Cont.)

The cooling rate increases with increasing  $h$ , particularly from 100 to 400  $\text{W/m}^2\cdot\text{K}$ . The temperature difference between the center and surface decreases with increasing  $t$  and, during the early stages of solidification, with decreasing  $h$ .

**COMMENTS:** Temperature gradients in the glass are largest during the early stages of solidification and increase with increasing  $h$ . Since thermal stresses increase with increasing temperature gradients, the propensity to induce defects due to crack formation in the glass increases with increasing  $h$ . Hence, there is a value of  $h$  above which product quality would suffer and the process should not be operated.

### PROBLEM 5S.9

**KNOWN:** Steel (plain carbon) billet of square cross-section initially at a uniform temperature of 30°C is placed in a soaking oven and subjected to a convection heating process with prescribed temperature and convection coefficient.

**FIND:** Time required for billet center temperature to reach 600°C.

**SCHEMATIC:**

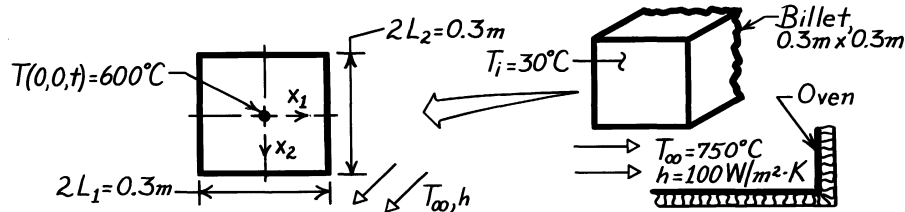

**ASSUMPTIONS:** (1) Two-dimensional conduction in  $x_1$  and  $x_2$  directions, (2) Constant properties, (3) Heat transfer to billet is by convection only.

**PROPERTIES:** Table A-1, Steel, plain carbon ( $T = (30+600)^\circ\text{C}/2 = 588\text{K} \approx 600\text{K}$ ):  $\rho = 7854 \text{ kg/m}^3$ ,  $c_p = 559 \text{ J/kg}\cdot\text{K}$ ,  $k = 48.0 \text{ W/m}\cdot\text{K}$ ,  $\alpha = k/\rho c_p = 1.093 \times 10^{-5} \text{ m}^2/\text{s}$ .

**ANALYSIS:** The billet corresponds to Case (e), Figure 5S.11 (infinite rectangular bar). Hence, the temperature distribution is of the form

$$\theta^*(x_1, x_2, t) = P(x_1, t) \times P(x_2, t)$$

where  $P(x, t)$  denotes the distribution corresponding to the plane wall. Because of symmetry in the  $x_1$  and  $x_2$  directions, the  $P$  functions are identical. Hence,

$$\frac{\theta(0,0,t)}{\theta_i} = \left[ \frac{\theta_o(0,t)}{\theta_i} \right]_{\text{Plane wall}}^2 \quad \text{where} \quad \begin{cases} \theta = T - T_\infty \\ \theta_i = T_i - T_\infty \\ \theta_o = T(0,t) - T_\infty \end{cases} \quad \text{and } L = 0.15\text{m}.$$

Substituting numerical values, find

$$\frac{\theta_o(0,t)}{\theta_i} = \left[ \frac{T(0,0,t) - T_\infty}{T_i - T_\infty} \right]^{1/2} = \left[ \frac{(600 - 750)^\circ\text{C}}{(30 - 750)^\circ\text{C}} \right]^{1/2} = 0.46.$$

Consider now the Heisler chart for the plane wall, Figure 5S.1. For the values

$$\theta_o^* = \frac{\theta_o}{\theta_i} \approx 0.46 \quad \text{Bi}^{-1} = \frac{k}{hL} = \frac{48.0 \text{ W/m}\cdot\text{K}}{100 \text{ W/m}^2\cdot\text{K} \times 0.15\text{m}} = 3.2$$

find

$$t^* = \text{Fo} = \frac{\alpha t}{L^2} \approx 3.2.$$

Hence,

$$t = \frac{3.2 L^2}{\alpha} = \frac{3.2 (0.15 \text{ m})^2}{1.093 \times 10^{-5} \text{ m}^2/\text{s}} = 6587 \text{ s} = 1.83 \text{ h}.$$

<



### PROBLEM 5S.10

**KNOWN:** Initial temperature of fire clay brick which is cooled by convection.

**FIND:** Center and corner temperatures after 50 minutes of cooling.

**SCHEMATIC:**

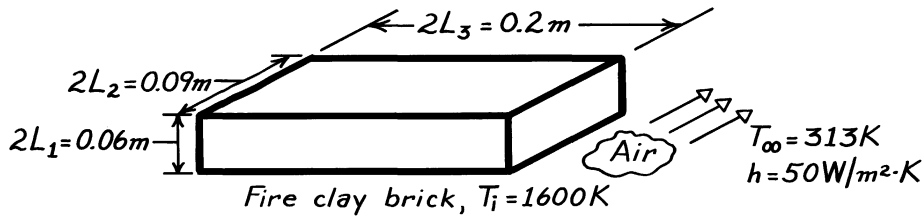

**ASSUMPTIONS:** (1) Homogeneous medium with constant properties, (2) Negligible radiation effects.

**PROPERTIES:** Table A-3, Fire clay brick (900K):  $\rho = 2050 \text{ kg/m}^3$ ,  $k = 1.0 \text{ W/m}\cdot\text{K}$ ,  $c_p = 960 \text{ J/kg}\cdot\text{K}$ .  $\alpha = 0.51 \times 10^{-6} \text{ m}^2/\text{s}$ .

**ANALYSIS:** From Figure 5S.11, the center temperature is given by

$$\frac{T(0,0,0,t) - T_\infty}{T_i - T_\infty} = P_1(0,t) \times P_2(0,t) \times P_3(0,t)$$

where  $P_1$ ,  $P_2$  and  $P_3$  must be obtained from Figure 5S.1.

$$L_1 = 0.03\text{m}: \quad Bi_1 = \frac{h L_1}{k} = 1.50 \quad Fo_1 = \frac{\alpha t}{L_1^2} = 1.70$$

$$L_2 = 0.045\text{m}: \quad Bi_2 = \frac{h L_2}{k} = 2.25 \quad Fo_2 = \frac{\alpha t}{L_2^2} = 0.756$$

$$L_3 = 0.10\text{m}: \quad Bi_3 = \frac{h L_3}{k} = 5.0 \quad Fo_3 = \frac{\alpha t}{L_3^2} = 0.153$$

Hence from Figure 5S.1,

$$P_1(0,t) \approx 0.22 \quad P_2(0,t) \approx 0.50 \quad P_3(0,t) \approx 0.85.$$

Hence, 
$$\frac{T(0,0,0,t) - T_\infty}{T_i - T_\infty} \approx 0.22 \times 0.50 \times 0.85 = 0.094$$

and the center temperature is

$$T(0,0,0,t) \approx 0.094(1600 - 313)\text{K} + 313 \text{ K} = 434 \text{ K}.$$

<

Continued ...

### PROBLEM 5S.10 (Cont.)

The corner temperature is given by

$$\frac{T(L_1, L_2, L_3, t) - T_\infty}{T_i - T_\infty} = P(L_1, t) \times P(L_2, t) \times P(L_3, t)$$

where

$$P(L_1, t) = \frac{\theta(L_1, t)}{\theta_o} \cdot P_1(0, t), \text{ etc.}$$

and similar forms can be written for  $L_2$  and  $L_3$ . From Figure 5S.2,

$$\frac{\theta(L_1, t)}{\theta_o} \approx 0.55 \quad \frac{\theta(L_2, t)}{\theta_o} \approx 0.43 \quad \frac{\theta(L_3, t)}{\theta_o} \approx 0.25.$$

Hence,

$$\begin{aligned} P(L_1, t) &\approx 0.55 \times 0.22 = 0.12 \\ P(L_2, t) &\approx 0.43 \times 0.50 = 0.22 \\ P(L_3, t) &\approx 0.85 \times 0.25 = 0.21 \end{aligned}$$

and

$$\frac{T(L_1, L_2, L_3, t) - T_\infty}{T_i - T_\infty} \approx 0.12 \times 0.22 \times 0.21 = 0.0056$$

or

$$T(L_1, L_2, L_3, t) \approx 0.0056(1600 - 313) \text{ K} + 313 \text{ K.}$$

The corner temperature is then

$$T(L_1, L_2, L_3, t) \approx 320 \text{ K.}$$

<

**COMMENTS:** (1) The foregoing temperatures are overpredicted by ignoring radiation, which is significant during the early portion of the transient.

(2) Note that, if the time required to reach a certain temperature were to be determined, an iterative approach would have to be used. The foregoing procedure would be used to compute the temperature for an assumed value of the time, and the calculation would be repeated until the specified temperature were obtained.

### PROBLEM 5S.11

**KNOWN:** Cylindrical copper pin, 100 mm long  $\times$  50 mm diameter, initially at 20°C; end faces are subjected to intense heating, suddenly raising them to 500°C; at the same time, the cylindrical surface is subjected to a convective heating process ( $T_\infty, h$ ).

**FIND:** (a) Temperature at center point of cylinder after a time of 8 seconds from sudden application of heat, (b) Consider parameters governing transient diffusion and justify simplifying assumptions that could be applied to this problem.

**SCHEMATIC:**

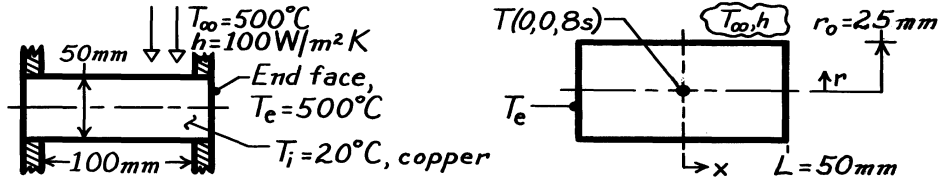

**ASSUMPTIONS:** (1) Two-dimensional conduction, (2) Constant properties and convection heat transfer coefficient.

**PROPERTIES:** Table A-1, Copper, pure ( $\bar{T} \approx (500 + 20)^\circ \text{C} / 2 \approx 500\text{K}$ ):  $\rho = 8933 \text{ kg/m}^3$ ,  $c = 407$

$\text{J/kg}\cdot\text{K}$ ,  $k = 386 \text{ W/m}\cdot\text{K}$ ,  $\alpha = k/\rho c = 386 \text{ W/m}\cdot\text{K} / 8933 \text{ kg/m}^3 \times 407 \text{ J/kg}\cdot\text{K} = 1.064 \times 10^{-4} \text{ m}^2/\text{s}$ .

**ANALYSIS:** (1) The pin can be treated as a two-dimensional system comprised of an infinite cylinder whose surface is exposed to a convection process ( $T_\infty, h$ ) and of a plane wall whose surfaces are maintained at a constant temperature ( $T_e$ ). This configuration corresponds to the short cylinder, Case (i) of Figure 5S.11,

$$\frac{\theta(r, x, t)}{\theta_i} = C(r, t) \times P(x, t). \quad (1)$$

For the infinite cylinder, using Figure 5S.4, with

$$\text{Bi} = \frac{hr_o}{k} = \frac{100 \text{ W/m}^2 \cdot \text{K} (25 \times 10^{-3} \text{ m})}{386 \text{ W/m}\cdot\text{K}} = 6.47 \times 10^{-3} \quad \text{and} \quad \text{Fo} = \frac{\alpha t}{r_o^2} = \frac{1.064 \times 10^{-4} \frac{\text{m}^2}{\text{s}} \times 8 \text{ s}}{(25 \times 10^{-3} \text{ m})^2} = 1.36,$$

$$\text{find} \quad C(0, 8\text{s}) = \left. \frac{\theta(0, 8\text{s})}{\theta_i} \right]_{\text{cyl}} \approx 1. \quad (2)$$

For the infinite plane wall, using Figure 5S.1, with

$$\text{Bi} = \frac{hL}{k} \rightarrow \infty \quad \text{or} \quad \text{Bi}^{-1} \rightarrow 0 \quad \text{and} \quad \text{Fo} = \frac{\alpha t}{L^2} = \frac{1.064 \times 10^{-4} \text{ m}^2/\text{s} \times 8 \text{ s}}{(50 \times 10^{-3} \text{ m})^2} = 0.34,$$

$$\text{find} \quad P(0, 8\text{s}) = \left. \frac{\theta(0, 8\text{s})}{\theta_i} \right]_{\text{wall}} \approx 0.5. \quad (3)$$

Combining Equations (2) and (3) with Eq. (1), find  $\frac{\theta(0, 0, 8\text{s})}{\theta_i} = \frac{T(0, 0, 8\text{s}) - T_\infty}{T_i - T_\infty} \approx 1 \times 0.5 = 0.5$

$$T(0, 0, 8\text{s}) = T_\infty + 0.5(T_i - T_\infty) = 500 + 0.5(20 - 500) = 260^\circ \text{C}. \quad <$$

(b) The parameters controlling transient conduction with convective boundary conditions are the Biot and Fourier numbers. Since  $\text{Bi} \ll 0.1$  for the cylindrical shape, we can assume radial gradients are negligible. That is, we need only consider conduction in the x-direction.

### PROBLEM 5S.12

**KNOWN:** Cylindrical-shaped meat roast weighing 2.25 kg, initially at 6°C, is placed in an oven and subjected to convection heating with prescribed ( $T_\infty, h$ ).

**FIND:** Time required for the center to reach a done temperature of 80°C.

**SCHEMATIC:**

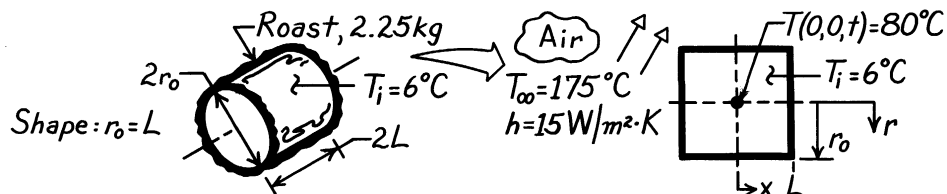

**ASSUMPTIONS:** (1) Two-dimensional conduction in  $x$  and  $r$  directions, (2) Uniform and constant properties, (3) Properties approximated as those of water.

**PROPERTIES:** Table A-6, Water, liquid ( $\bar{T} = (80 + 6)^\circ\text{C}/2 \approx 315\text{K}$ ):  $\rho = 1/v_f = 1/1.009 \times 10^{-3} \text{ m}^3/\text{kg} = 991.1 \text{ kg/m}^3$ ,  $c_{p,f} = 4179 \text{ J/kg}\cdot\text{K}$ ,  $k = 0.634 \text{ W/m}\cdot\text{K}$ ,  $\alpha = k/\rho c = 1.531 \times 10^{-7} \text{ m}^2/\text{s}$ .

**ANALYSIS:** The dimensions of the roast are determined from the requirement  $r_o = L$  and knowledge of its weight and density,

$$M = \rho V = \rho \cdot 2L \cdot \pi r_o^2 \quad \text{or} \quad r_o = L = \left[ \frac{M}{2\pi\rho} \right]^{1/3} = \left[ \frac{2.25 \text{ kg}}{2\pi \cdot 991.1 \text{ kg/m}^3} \right]^{1/3} = 0.0712 \text{ m}. \quad (1)$$

The roast corresponds to Case (i), Figure 5S.11, and the temperature distribution may be expressed as the product of one-dimensional solutions,  $\frac{T(x,r,t) - T_\infty}{T_i - T_\infty} = P(x,t) \times C(r,t)$ , where

$P(x,t)$  and  $C(r,t)$  are defined by Equations 5S.2 and 5S.3, respectively. For the center of the cylinder,

$$\frac{T(0,0,t) - T_\infty}{T_i - T_\infty} = \frac{(80 - 175)^\circ\text{C}}{(6 - 175)^\circ\text{C}} = 0.56. \quad (2)$$

In terms of the product solutions,

$$\frac{T(0,0,t) - T_\infty}{T_i - T_\infty} = 0.56 = \left[ \frac{T(0,t) - T_\infty}{T_i - T_\infty} \right]_{\text{wall}} \times \left[ \frac{T(0,t) - T_\infty}{T_i - T_\infty} \right]_{\text{cylinder}} \quad (3)$$

For each of these shapes, we need to find values of  $\theta_o/\theta_i$  such that their product satisfies Equation (3). For both shapes,

$$\text{Bi} = \frac{h r_o}{k} = \frac{hL}{k} = \frac{15 \text{ W/m}^2 \cdot \text{K} \times 0.0712 \text{ m}}{0.634 \text{ W/m} \cdot \text{K}} = 1.68 \quad \text{or} \quad \text{Bi}^{-1} \approx 0.6$$

$$\text{Fo} = \alpha t/r_o^2 = \alpha t/L^2 = 1.53 \times 10^{-7} \text{ m}^2/\text{s} \times t / (0.0712 \text{ m})^2 = 3.020 \times 10^{-5} t.$$

Continued ...

**PROBLEM 5S.12 (Cont.)**

A trial-and-error solution is necessary. Begin by assuming a value of  $Fo$ ; obtain the respective  $\theta_o/\theta_i$  values from Figures 5S.1 and 5S.4; test whether their product satisfies Equation (3).

Two trials are shown as follows:

<i>Trial</i>	$Fo$	$t(\text{hrs})$	$\theta_o/\theta_i)_{\text{wall}}$	$\theta_o/\theta_i)_{\text{cyl}}$	$\left. \frac{\theta_o}{\theta_i} \right]_{\text{w}} \times \left. \frac{\theta_o}{\theta_i} \right]_{\text{cyl}}$
1	0.4	3.68	0.72	0.50	0.36
2	0.3	2.75	0.78	0.68	0.53

For Trial 2, the product of 0.53 agrees closely with the value of 0.56 from Equation (2). Hence, it will take approximately  $2 \frac{3}{4}$  hours to roast the meat.

### PROBLEM 5S.13

**KNOWN:** A long alumina rod, initially at a uniform temperature of 850 K, is suddenly exposed to a cooler fluid.

**FIND:** Temperature of the rod after 30 s, at an exposed end,  $T(0,0,t)$ , and at an axial distance 6mm from the end,  $T(0,6\text{ mm},t)$ .

**SCHEMATIC:**

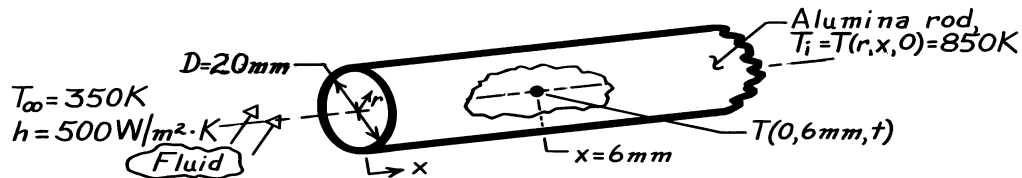

**ASSUMPTIONS:** (1) Two-dimensional conduction in  $(r,x)$  directions, (2) Constant properties, (3) Convection coefficient is same on end and cylindrical surfaces.

**PROPERTIES:** Table A-2, Alumina, polycrystalline aluminum oxide (assume  $\bar{T} \approx (850 + 600)\text{K}/2 = 725\text{K}$ ):  $\rho = 3970\text{ kg/m}^3$ ,  $c = 1154\text{ J/kg}\cdot\text{K}$ ,  $k = 12.4\text{ W/m}\cdot\text{K}$ .

**ANALYSIS:** First, check if system behaves as a lumped capacitance. Find

$$Bi = \frac{hL_c}{k} = \frac{h(r_o/2)}{k} = \frac{500\text{ W/m}\cdot\text{K}(0.010\text{m}/2)}{12.4\text{ W/m}\cdot\text{K}} = 0.202.$$

Since  $Bi > 0.1$ , rod does not behave as spacewise isothermal object. Hence, treat rod as a semi-infinite cylinder, the multi-dimensional system Case (f), Figure 5S.11.

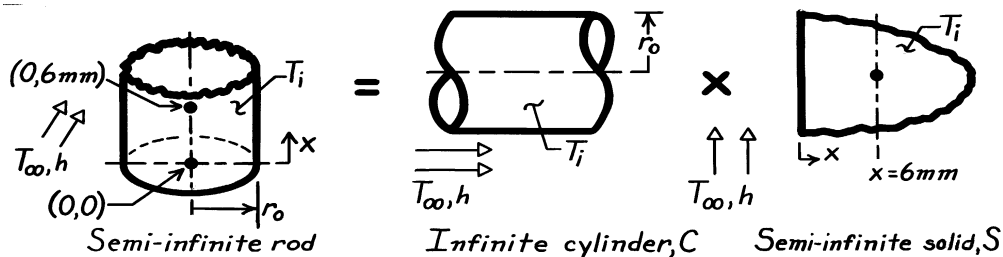

The product solution can be written as

$$\theta^*(r,x,t) = \frac{\theta(r,x,t)}{\theta_i} = \frac{\theta(r,t)}{\theta_i} \times \frac{\theta(x,t)}{\theta_i} = C(r^*,t^*) \times S(x^*,t^*)$$

*Infinite cylinder, C*( $r^*,t^*$ ). Using the Heisler charts with  $r^* = r = 0$  and

$$Bi^{-1} = \left[ \frac{h r_o}{k} \right]^{-1} = \left[ \frac{500\text{ W/m}^2 \cdot \text{K} \times 0.01\text{m}}{12.4\text{ W/m}\cdot\text{K}} \right]^{-1} = 2.48.$$

Evaluate  $\alpha = k/\rho c = 2.71 \times 10^{-6}\text{ m}^2/\text{s}$ , find  $Fo = \alpha t/r_o^2 = 2.71 \times 10^{-6}\text{ m}^2/\text{s} \times 30\text{s}/(0.01\text{m})^2 = 0.812$ . From the Heisler chart, Figure 5S.4, with  $Bi^{-1} = 2.48$  and  $Fo = 0.812$ , read  $C(0,t^*) = \theta(0,t)/\theta_i = 0.61$ .

Continued ...

**PROBLEM 5S.13 (Cont.)**

*Semi-infinite medium, S(x\*,t\*).* Recognize this as Case (3), Figure 5.7. From Equation 5.63, note that the LHS needs to be transformed as follows,

$$\frac{T - T_i}{T_\infty - T_i} = 1 - \frac{T - T_\infty}{T_i - T_\infty} \quad S(x,t) = \frac{T - T_\infty}{T_i - T_\infty}.$$

Thus,

$$S(x,t) = 1 - \left\{ \operatorname{erfc} \left[ \frac{x}{2(\alpha t)^{1/2}} \right] - \left[ \exp \left[ \frac{hx}{k} + \frac{h^2 \alpha t}{k^2} \right] \right] \left[ \operatorname{erfc} \left[ \frac{x}{2(\alpha t)^{1/2}} + \frac{h(\alpha t)^{1/2}}{k} \right] \right] \right\}.$$

Evaluating this expression at the surface ( $x = 0$ ) and 6 mm from the exposed end, find

$$S(0,30s) = 1 - \left\{ \operatorname{erfc}(0) - \left[ \exp \left[ 0 + \frac{(500 \text{ W/m}^2 \cdot \text{K})^2 \cdot 2.71 \times 10^{-6} \text{ m}^2 / \text{s} \times 30\text{s}}{(12.4 \text{ W/m} \cdot \text{K})^2} \right] \right] \left[ \operatorname{erfc} \left[ 0 + \frac{500 \text{ W/m}^2 \cdot \text{K} (2.71 \times 10^{-6} \text{ m}^2 / \text{s} \times 30\text{s})^{1/2}}{12.4 \text{ W/m} \cdot \text{K}} \right] \right] \right\}$$

$$S(0,30s) = 1 - \left\{ 1 - \left[ \exp(0.1322) \right] \left[ \operatorname{erfc}(0.3636) \right] \right\} = 0.693.$$

Note that Table B.2 was used to evaluate the complementary error function,  $\operatorname{erfc}(w)$ .

$$S(6\text{mm},30s) = 1 - \left\{ \operatorname{erfc} \left[ \frac{0.006\text{m}}{2(2.71 \times 10^{-6} \text{ m}^2 / \text{s} \times 30\text{s})^{1/2}} \right] - \left[ \exp \left[ \frac{500 \text{ W/m}^2 \cdot \text{K} \times 0.006\text{m}}{12.4 \text{ W/m} \cdot \text{K}} + 0.1322 \right] \right] \left[ \operatorname{erfc}(0.3327 + 0.3636) \right] \right\} = 0.835.$$

The product solution can now be evaluated for each location. At (0,0),

$$\theta^*(0,0,t) = \frac{T(0,0,30s) - T_\infty}{T_i - T_\infty} = C(0,t^*) \times S(0,t^*) = 0.61 \times 0.693 = 0.423.$$

Hence,  $T(0,0,30s) = T_\infty + 0.423(T_i - T_\infty) = 350\text{K} + 0.423(850 - 350)\text{K} = 561 \text{ K.} <$

At (0,6mm),

$$\theta^*(0,6\text{mm},t) = C(0,t^*) \times S(6\text{mm},t^*) = 0.61 \times 0.835 = 0.509$$

$$T(0,6\text{mm},30s) = 604 \text{ K.} <$$

**COMMENTS:** Note that the temperature at which the properties were evaluated was a good estimate.

### PROBLEM 5S.14

**KNOWN:** Stainless steel cylinder of Example 5S.1, 80-mm diameter by 60-mm length, initially at 600 K, suddenly quenched in an oil bath at 300 K with  $h = 500 \text{ W/m}^2 \cdot \text{K}$ . Use the *Transient Conduction, Plane Wall and Cylinder models of IHT* to obtain the following solutions.

**FIND:** (a) Calculate the temperatures  $T(r,x,t)$  after 3 min: at the cylinder center,  $T(0, 0, 3 \text{ min})$ , at the center of a circular face,  $T(0, L, 3 \text{ min})$ , and at the midheight of the side,  $T(r_o, 0, 3 \text{ min})$ ; compare your results with those in the example; (b) Calculate and plot temperature histories at the cylinder center,  $T(0, 0, t)$ , the mid-height of the side,  $T(r_o, 0, t)$ , for  $0 \leq t \leq 10 \text{ min}$ ; comment on the gradients and what effect they might have on phase transformations and thermal stresses; and (c) For  $0 \leq t \leq 10 \text{ min}$ , calculate and plot the temperature histories at the cylinder center,  $T(0, 0, t)$ , for convection coefficients of 500 and  $1000 \text{ W/m}^2 \cdot \text{K}$ .

**SCHEMATIC:**

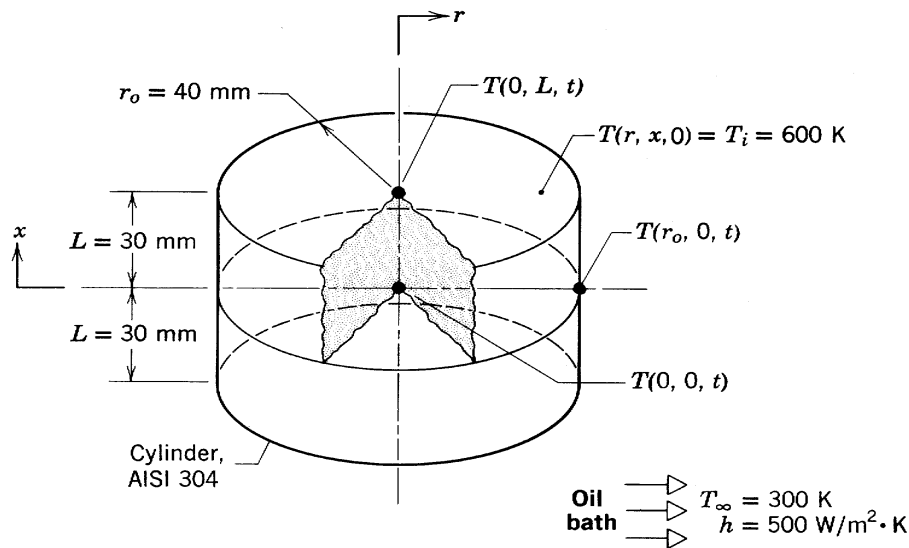

**ASSUMPTIONS:** (1) Two-dimensional conduction in  $r$ - and  $x$ -coordinates, (2) Constant properties.

**PROPERTIES:** Stainless steel (*Example 5S.1*):  $\rho = 7900 \text{ kg/m}^3$ ,  $c = 526 \text{ J/kg} \cdot \text{K}$ ,  $k = 17.4 \text{ W/m} \cdot \text{K}$ .

**ANALYSIS:** The following results were obtained using the *Transient Conduction models for the Plane Wall and Cylinder of IHT*. Salient portions of the code are provided in the Comments.

(a) Following the methodology for a product solution outlined in Example 5S.1, the following results were obtained at  $t = t_0 = 3 \text{ min}$

$(r, x, t)$	$P(x, t)$	$C(r, t)$	$T(r, x, t)$ -IHT (K)	$T(r, x, t)$ -Ex (K)
$0, 0, t_0$	0.6357	0.5388	402.7	405
$0, L, t_0$	0.4365	0.5388	370.5	372
$r_o, 0, t_0$	0.6357	0.3273	362.4	365

Continued ...



## PROBLEM 5S.14 (Cont.)

The temperatures from the one-term series calculations of the Example 5S.1 are systematically higher than those resulting from the *IHT* multiple-term series model, which is the more accurate method.

(b) The temperature histories for the center and mid-height of the side locations are shown in the graph below. Note that at early times, the temperature difference between these locations, and hence the gradient, is large. Large differences could cause variations in microstructure and hence, mechanical properties, as well as induce residual thermal stresses.

(c) Effect of doubling the convection coefficient is to increase the quenching rate, but much less than by a factor of two as can be seen in the graph below.

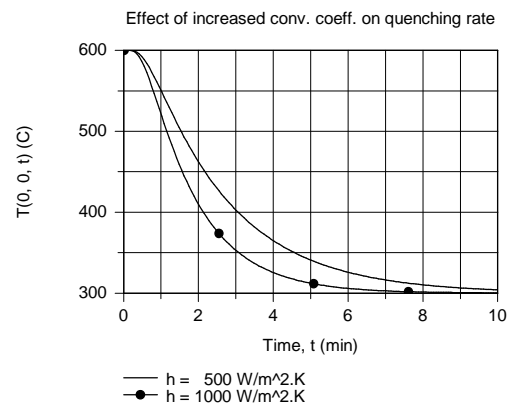
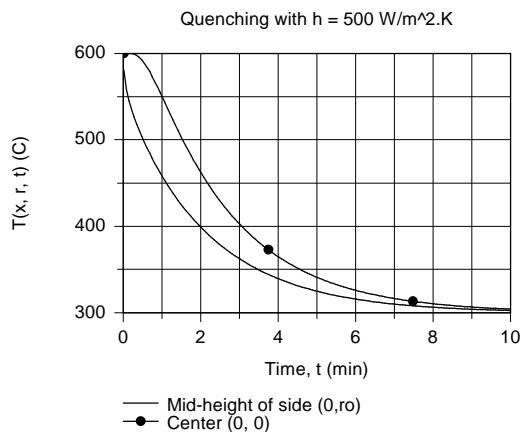

**COMMENTS:** From *IHT* menu for *Transient Conduction* | *Plane Wall* and *Cylinder*, the models were combined to solve the product solution. Key portions of the code, less the input variables, are copied below.

**// Plane wall temperature distribution**

```
// The temperature distribution is
T_xtP = T_xt_trans("Plane Wall",xstar,FoP,BiP,Ti,Tinf) // Eq 5.42
// The dimensionless parameters are
xstar = x / L
BiP = h * L / k // Eq 5.9
FoP = alpha * t / L^2 // Eq 5.33
alpha = k / (rho * cp)
// Dimensionless representation, P(x,t)
P_xt = (T_xtP - Tinf) / (Ti - Tinf)
```

**// Cylinder temperature distribution**

```
// The temperature distribution T(r,t) is
T_rtC = T_xt_trans("Cylinder",rstar,FoC,BiC,Ti,Tinf) // Eq 5.50
// The dimensionless parameters are
rstar = r / ro
BiC = h * ro / k
FoC = alpha * t / ro^2
// Dimensionless representation, C(r,t)
C_rt = (T_rtC - Tinf) / (Ti - Tinf)
```

**// Product solution temperature distribution**

```
(T_xrt - Tinf) / (Ti - Tinf) = P_xt * C_rt
```

## PROBLEM 6S.1

**KNOWN:** Two-dimensional flow conditions for which  $v = 0$  and  $T = T(y)$ .

**FIND:** (a) Verify that  $u = u(y)$ , (b) Derive the x-momentum equation, (c) Derive the energy equation.

**SCHEMATIC:**

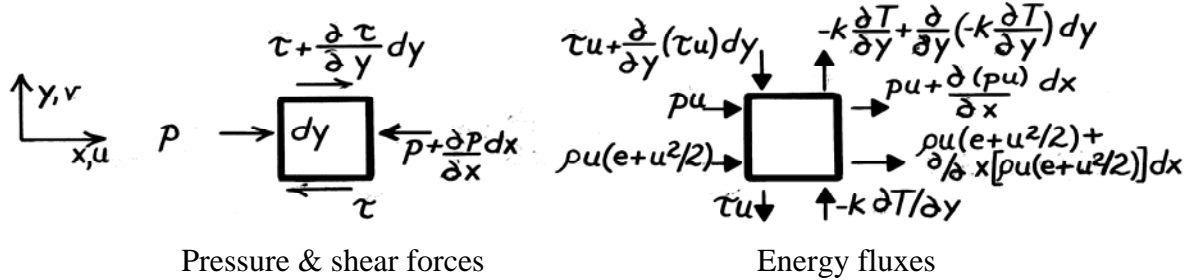

**ASSUMPTIONS:** (1) Steady-state conditions, (2) Incompressible fluid with constant properties, (3) Negligible body forces, (4)  $v = 0$ , (5)  $T = T(y)$  or  $\partial T / \partial x = 0$ , (6) Thermal energy generation occurs only by viscous dissipation.

**ANALYSIS:** (a) From the mass continuity equation, it follows from the prescribed conditions that  $\partial u / \partial x = 0$ . Hence  $u = u(y)$ .

(b) From Newton's second law of motion,  $\Sigma F_x = (\text{Rate of increase of fluid momentum})_x$ ,

$$\left[ p - \left[ p + \frac{\partial p}{\partial x} dx \right] \right] dy \cdot 1 + \left[ -\tau + \left[ \tau + \frac{\partial \tau}{\partial y} dy \right] \right] dx \cdot 1 = \left\{ (\rho u)u + \frac{\partial}{\partial x} [(\rho u)u] dx \right\} dy \cdot 1 - (\rho u)u dy \cdot 1$$

Hence, with  $\tau = \mu(\partial u / \partial y)$ , it follows that

$$-\frac{\partial p}{\partial x} + \frac{\partial \tau}{\partial y} = \frac{\partial}{\partial x} [(\rho u)u] = 0 \quad \frac{\partial p}{\partial x} = \mu \frac{\partial^2 u}{\partial y^2}. \quad <$$

(c) From the conservation of energy requirement and the prescribed conditions, it follows that

$$\dot{E}_{\text{in}} - \dot{E}_{\text{out}} = 0, \text{ or}$$

$$\left[ pu + \rho u \left( e + u^2 / 2 \right) \right] dy \cdot 1 + \left[ -k \frac{\partial T}{\partial y} + \tau u + \frac{\partial (\tau u)}{\partial y} dy \right] dx \cdot 1 - \left\{ pu + \frac{\partial}{\partial x} (pu) dx + \rho u \left( e + u^2 / 2 \right) + \frac{\partial}{\partial x} \left[ \rho u \left( e + u^2 / 2 \right) \right] dx \right\} dy \cdot 1 - \left[ \tau u - k \frac{\partial T}{\partial y} + \frac{\partial}{\partial y} \left[ -k \frac{\partial T}{\partial y} \right] dy \right] dx \cdot 1 = 0$$

or, 
$$\frac{\partial (\tau u)}{\partial y} - \frac{\partial}{\partial x} (pu) - \frac{\partial}{\partial x} \left[ \rho u \left( e + u^2 / 2 \right) \right] + \frac{\partial}{\partial y} \left[ k \frac{\partial T}{\partial y} \right] = 0$$

$$\tau \frac{\partial u}{\partial y} + u \frac{\partial \tau}{\partial y} - u \frac{\partial p}{\partial x} + k \frac{\partial^2 T}{\partial y^2} = 0.$$

Noting that the second and third terms cancel from the momentum equation,

$$\mu \left[ \frac{\partial u}{\partial y} \right]^2 + k \left[ \frac{\partial^2 T}{\partial y^2} \right] = 0. \quad <$$

## PROBLEM 6S.2

**KNOWN:** Oil properties, journal and bearing temperatures, and journal speed for a lightly loaded journal bearing.

**FIND:** Maximum oil temperature.

**SCHEMATIC:**

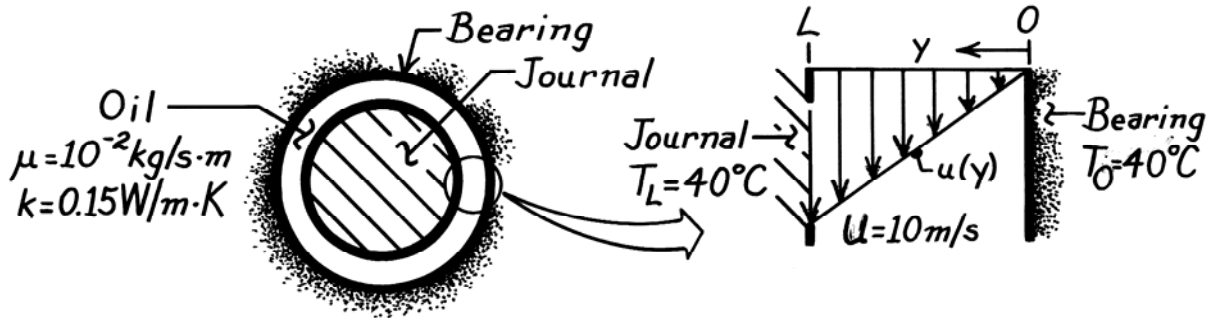

**ASSUMPTIONS:** (1) Steady-state conditions, (2) Incompressible fluid with constant properties, (3) Clearance is much less than journal radius and flow is Couette.

**ANALYSIS:** The temperature distribution corresponds to the result obtained in the text Example on Couette flow,

$$T(y) = T_0 + \frac{\mu}{2k} U^2 \left[ \frac{y}{L} - \left[ \frac{y}{L} \right]^2 \right].$$

The position of maximum temperature is obtained from

$$\frac{dT}{dy} = 0 = \frac{\mu}{2k} U^2 \left[ \frac{1}{L} - \frac{2y}{L^2} \right]$$

or,  $y = L/2$ .

The temperature is a maximum at this point since  $d^2T/dy^2 < 0$ . Hence,

$$T_{\max} = T(L/2) = T_0 + \frac{\mu}{2k} U^2 \left[ \frac{1}{2} - \frac{1}{4} \right] = T_0 + \frac{\mu U^2}{8k}$$

$$T_{\max} = 40^\circ\text{C} + \frac{10^{-2} \text{ kg/s} \cdot \text{m} (10 \text{ m/s})^2}{8 \times 0.15 \text{ W/m} \cdot \text{K}}$$

$$T_{\max} = 40.83^\circ\text{C}.$$

<

**COMMENTS:** Note that  $T_{\max}$  increases with increasing  $\mu$  and  $U$ , decreases with increasing  $k$ , and is independent of  $L$ .

### PROBLEM 6S.3

**KNOWN:** Diameter, clearance, rotational speed and fluid properties of a lightly loaded journal bearing. Temperature of bearing.

**FIND:** (a) Temperature distribution in the fluid, (b) Rate of heat transfer from bearing and operating power.

**SCHEMATIC:**

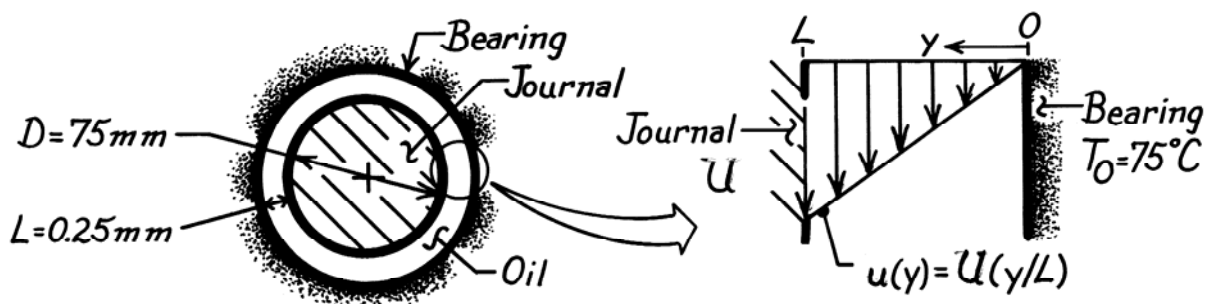

**ASSUMPTIONS:** (1) Steady-state conditions, (2) Incompressible fluid with constant properties, (3) Couette flow.

**PROPERTIES:** Oil (Given):  $\rho = 800 \text{ kg/m}^3$ ,  $\nu = 10^{-5} \text{ m}^2/\text{s}$ ,  $k = 0.13 \text{ W/m}\cdot\text{K}$ ;  $\mu = \rho\nu = 8 \times 10^{-3} \text{ kg/s}\cdot\text{m}$ .

**ANALYSIS:** (a) For Couette flow, the velocity distribution is linear,  $u(y) = U(y/L)$ , and the energy equation and general form of the temperature distribution are

$$k \frac{d^2 T}{dy^2} = -\mu \left[ \frac{du}{dy} \right]^2 = -\mu \left[ \frac{U}{L} \right]^2 \quad T = -\frac{\mu}{2k} \left[ \frac{U}{L} \right]^2 y^2 + \frac{C_1}{k} y + C_2.$$

Considering the boundary conditions  $dT/dy|_{y=L} = 0$  and  $T(0) = T_0$ , find  $C_2 = T_0$  and  $C_1 = \mu U^2/L$ . Hence,

$$T = T_0 + \left( \mu U^2 \right) / k \left[ \left( y/L \right) - 1/2 \left( y/L \right)^2 \right]. \quad <$$

(b) Applying Fourier's law at  $y = 0$ , the rate of heat transfer per unit length to the bearing is

$$q' = -k (\pi D) \left. \frac{dT}{dy} \right|_{y=0} = -(\pi D) \frac{\mu U^2}{L} = -(\pi \times 75 \times 10^{-3} \text{ m}) \frac{8 \times 10^{-3} \text{ kg/s}\cdot\text{m} (14.14 \text{ m/s})^2}{0.25 \times 10^{-3} \text{ m}} = -1507.5 \text{ W/m}$$

where the velocity is determined as

$$U = (D/2) \omega = 0.0375 \text{ m} \times 3600 \text{ rev/min} (2\pi \text{ rad/rev}) / (60 \text{ s/min}) = 14.14 \text{ m/s}.$$

The journal power requirement is

$$P' = F'_{(y=L)} U = \tau_{s(y=L)} \cdot \pi D \cdot U$$

$$P' = 452.5 \text{ kg/s}^2 \cdot \text{m} \left( \pi \times 75 \times 10^{-3} \text{ m} \right) 14.14 \text{ m/s} = 1507.5 \text{ kg}\cdot\text{m/s}^3 = 1507.5 \text{ W/m} \quad <$$

where the shear stress at  $y = L$  is

$$\tau_{s(y=L)} = \mu \left( \partial u / \partial y \right)_{y=L} = \mu \frac{U}{L} = 8 \times 10^{-3} \text{ kg/s}\cdot\text{m} \left[ \frac{14.14 \text{ m/s}}{0.25 \times 10^{-3} \text{ m}} \right] = 452.5 \text{ kg/s}^2 \cdot \text{m}.$$

**COMMENTS:** Note that  $q' = P'$ , which is consistent with the energy conservation requirement.

## PROBLEM 6S.4

**KNOWN:** Conditions associated with the Couette flow of air or water.

**FIND:** (a) Force and power requirements per unit surface area, (b) Viscous dissipation, (c) Maximum fluid temperature.

**SCHEMATIC:**

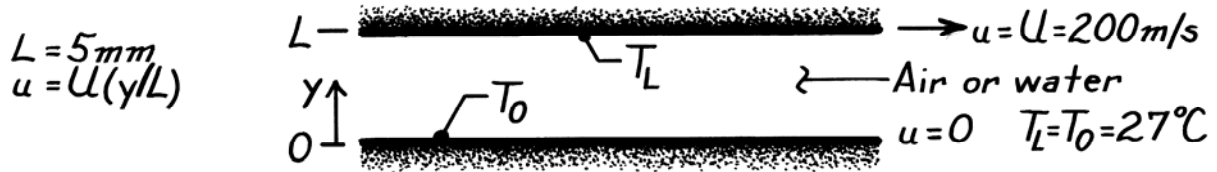

**ASSUMPTIONS:** (1) Fully-developed Couette flow, (2) Incompressible fluid with constant properties.

**PROPERTIES:** Table A-4, Air (300K):  $\mu = 184.6 \times 10^{-7} \text{ N}\cdot\text{s}/\text{m}^2$ ,  $k = 26.3 \times 10^{-3} \text{ W}/\text{m}\cdot\text{K}$ ; Table A-6, Water (300K):  $\mu = 855 \times 10^{-6} \text{ N}\cdot\text{s}/\text{m}^2$ ,  $k = 0.613 \text{ W}/\text{m}\cdot\text{K}$ .

**ANALYSIS:** (a) The force per unit area is associated with the shear stress. Hence, with the linear velocity profile for Couette flow,  $\tau = \mu(du/dy) = \mu(U/L)$ .

$$\text{Air:} \quad \tau_{\text{air}} = 184.6 \times 10^{-7} \text{ N}\cdot\text{s}/\text{m}^2 \times \frac{200 \text{ m/s}}{0.005 \text{ m}} = 0.738 \text{ N}/\text{m}^2 \quad <$$

$$\text{Water:} \quad \tau_{\text{water}} = 855 \times 10^{-6} \text{ N}\cdot\text{s}/\text{m}^2 \times \frac{200 \text{ m/s}}{0.005 \text{ m}} = 34.2 \text{ N}/\text{m}^2.$$

With the required power given by  $P/A = \tau \cdot U$ ,

$$\text{Air:} \quad (P/A)_{\text{air}} = (0.738 \text{ N}/\text{m}^2) 200 \text{ m/s} = 147.6 \text{ W}/\text{m}^2 \quad <$$

$$\text{Water:} \quad (P/A)_{\text{water}} = (34.2 \text{ N}/\text{m}^2) 200 \text{ m/s} = 6840 \text{ W}/\text{m}^2.$$

(b) The viscous dissipation is  $\mu\Phi = \mu(du/dy)^2 = \mu(U/L)^2$ . Hence,

$$\text{Air:} \quad (\mu\Phi)_{\text{air}} = 184.6 \times 10^{-7} \frac{\text{N}\cdot\text{s}}{\text{m}^2} \left[ \frac{200 \text{ m/s}}{0.005 \text{ m}} \right]^2 = 2.95 \times 10^4 \text{ W}/\text{m}^3 \quad <$$

$$\text{Water:} \quad (\mu\Phi)_{\text{water}} = 855 \times 10^{-6} \frac{\text{N}\cdot\text{s}}{\text{m}^2} \left[ \frac{200 \text{ m/s}}{0.005 \text{ m}} \right]^2 = 1.37 \times 10^6 \text{ W}/\text{m}^3.$$

(c) From the solution to Part 4 of Example 6S.1, the location of the maximum temperature corresponds to  $y_{\text{max}} = L/2$ . Hence,  $T_{\text{max}} = T_0 + \mu U^2 / 8k$  and

$$\text{Air:} \quad (T_{\text{max}})_{\text{air}} = 27^\circ\text{C} + \frac{184.6 \times 10^{-7} \text{ N}\cdot\text{s}/\text{m}^2 (200 \text{ m/s})^2}{8 \times 0.0263 \text{ W}/\text{m}\cdot\text{K}} = 30.5^\circ\text{C} \quad <$$

$$\text{Water:} \quad (T_{\text{max}})_{\text{water}} = 27^\circ\text{C} + \frac{855 \times 10^{-6} \text{ N}\cdot\text{s}/\text{m}^2 (200 \text{ m/s})^2}{8 \times 0.613 \text{ W}/\text{m}\cdot\text{K}} = 34.0^\circ\text{C}.$$

**COMMENTS:** (1) The viscous dissipation associated with the entire fluid layer,  $\mu\Phi(LA)$ , must equal the power,  $P$ . (2) Although  $(\mu\Phi)_{\text{water}} \gg (\mu\Phi)_{\text{air}}$ ,  $k_{\text{water}} \gg k_{\text{air}}$ . Hence,

$$T_{\text{max,water}} \approx T_{\text{max,air}}.$$

### PROBLEM 6S.5

**KNOWN:** Velocity and temperature difference of plates maintaining Couette flow. Mean temperature of air, water or oil between the plates.

**FIND:** (a) Pr·Ec product for each fluid, (b) Pr·Ec product for air with plate at sonic velocity.

**SCHEMATIC:**

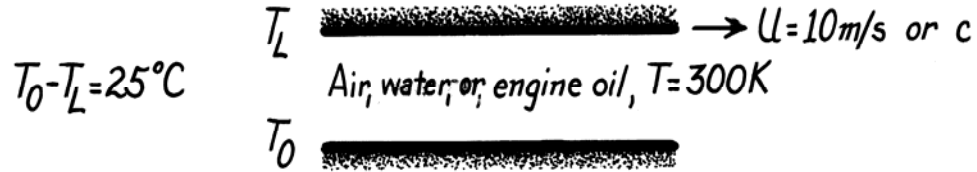

**ASSUMPTIONS:** (1) Steady-state conditions, (2) Couette flow, (3) Air is at 1 atm.

**PROPERTIES:** Table A-4, Air (300K, 1atm),  $c_p = 1007\text{ J/kg}\cdot\text{K}$ ,  $\text{Pr} = 0.707$ ,  $\gamma = 1.4$ ,  $R = 287.02\text{ J/kg}\cdot\text{K}$ ; Table A-6, Water (300K):  $c_p = 4179\text{ J/kg}\cdot\text{K}$ ,  $\text{Pr} = 5.83$ ; Table A-5, Engine oil (300K),  $c_p = 1909\text{ J/kg}\cdot\text{K}$ ,  $\text{Pr} = 6400$ .

**ANALYSIS:** The product of the Prandtl and Eckert numbers is dimensionless,

$$\text{Pr} \cdot \text{Ec} = \text{Pr} \frac{U^2}{c_p \Delta T} \left( \frac{\text{m}^2/\text{s}^2}{(\text{J/kg}\cdot\text{K})\text{K}} \right) \left( \frac{\text{m}^2/\text{s}^2}{(\text{kg}\cdot\text{m}^2/\text{s}^2)/\text{kg}} \right)$$

Substituting numerical values, find

	<i>Air</i>	<i>Water</i>	<i>Oil</i>	
Pr·Ec	0.0028	0.0056	13.41	<

(b) For an ideal gas, the speed of sound is

$$c = (\gamma R T)^{1/2}$$

where R, the gas constant for air, is  $R_u/M = 8.315\text{ kJ/kmol}\cdot\text{K}/(28.97\text{ kg/kmol}) = 287.02\text{ J/kg}\cdot\text{K}$ . Hence, at 300K for air,

$$U = c = (1.4 \times 287.02\text{ J/kg}\cdot\text{K} \times 300\text{K})^{1/2} = 347.2\text{ m/s}.$$

For sonic velocities, it follows that

$$\text{Pr} \cdot \text{Ec} = 0.707 \frac{(347.2\text{ m/s})^2}{1007\text{ J/kg}\cdot\text{K} \times 25\text{K}} = 3.38. \quad <$$

**COMMENTS:** From the above results it follows that viscous dissipation effects must be considered in the high speed flow of gases and in oil flows at moderate speeds. For Pr·Ec to be less than 0.1 in air with  $\Delta T = 25^\circ\text{C}$ , U should be  $\lesssim 60\text{ m/s}$ .

### PROBLEM 6S.6

**KNOWN:** Couette flow with moving plate isothermal and stationary plate insulated.

**FIND:** Temperature of stationary plate and heat flux at the moving plate.

**SCHEMATIC:**

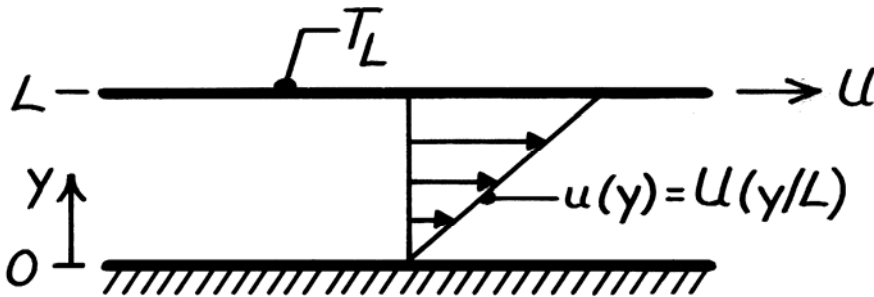

**ASSUMPTIONS:** (1) Steady-state conditions, (2) Incompressible fluid with constant properties, (3) Couette flow.

**ANALYSIS:** The energy equation is given by

$$0 = k \left[ \frac{\partial^2 T}{\partial y^2} \right] + \mu \left[ \frac{\partial u}{\partial y} \right]^2$$

Integrating twice find the general form of the temperature distribution,

$$\frac{\partial^2 T}{\partial y^2} = -\frac{\mu}{k} \left[ \frac{U}{L} \right]^2 \quad \frac{\partial T}{\partial y} = -\frac{\mu}{k} \left[ \frac{U}{L} \right]^2 y + C_1$$

$$T(y) = -\frac{\mu}{2k} \left[ \frac{U}{L} \right]^2 y^2 + C_1 y + C_2.$$

Consider the boundary conditions to evaluate the constants,

$$\left. \frac{\partial T}{\partial y} \right|_{y=0} = 0 \rightarrow C_1 = 0 \quad \text{and} \quad T(L) = T_L \rightarrow C_2 = T_L + \frac{\mu}{2k} U^2.$$

Hence, the temperature distribution is

$$T(y) = T_L + \left[ \frac{\mu U^2}{2k} \right] \left[ 1 - \left[ \frac{y}{L} \right]^2 \right].$$

The temperature of the lower plate ( $y = 0$ ) is

$$T(0) = T_L + \left[ \frac{\mu U^2}{2k} \right]. \quad <$$

The heat flux to the upper plate ( $y = L$ ) is

$$q''(L) = -k \left. \frac{\partial T}{\partial y} \right|_{y=L} = \frac{\mu U^2}{L}. \quad <$$

**COMMENTS:** The heat flux at the top surface may also be obtained by integrating the viscous dissipation over the fluid layer height. For a control volume about a unit area of the fluid layer,

$$\dot{E}_g'' = \dot{E}_{\text{out}}'' \quad \int_0^L \mu \left[ \frac{\partial u}{\partial y} \right]^2 dy = q''(L) \quad q''(L) = \frac{\mu U^2}{L}.$$

## PROBLEM 6S.7

**KNOWN:** Couette flow with heat transfer. Lower (insulated) plate moves with speed  $U$  and upper plate is stationary with prescribed thermal conductivity and thickness. Outer surface of upper plate maintained at constant temperature,  $T_{sp} = 40^\circ\text{C}$ .

**FIND:** (a) On  $T$ - $y$  coordinates, sketch the temperature distribution in the oil and the stationary plate, and (b) An expression for the temperature at the lower surface of the oil film,  $T(0) = T_o$ , in terms of the plate speed  $U$ , the stationary plate parameters ( $T_{sp}$ ,  $k_{sp}$ ,  $L_{sp}$ ) and the oil parameters ( $\mu$ ,  $k_o$ ,  $L_o$ ). Determine this temperature for the prescribed conditions.

**SCHEMATIC:**

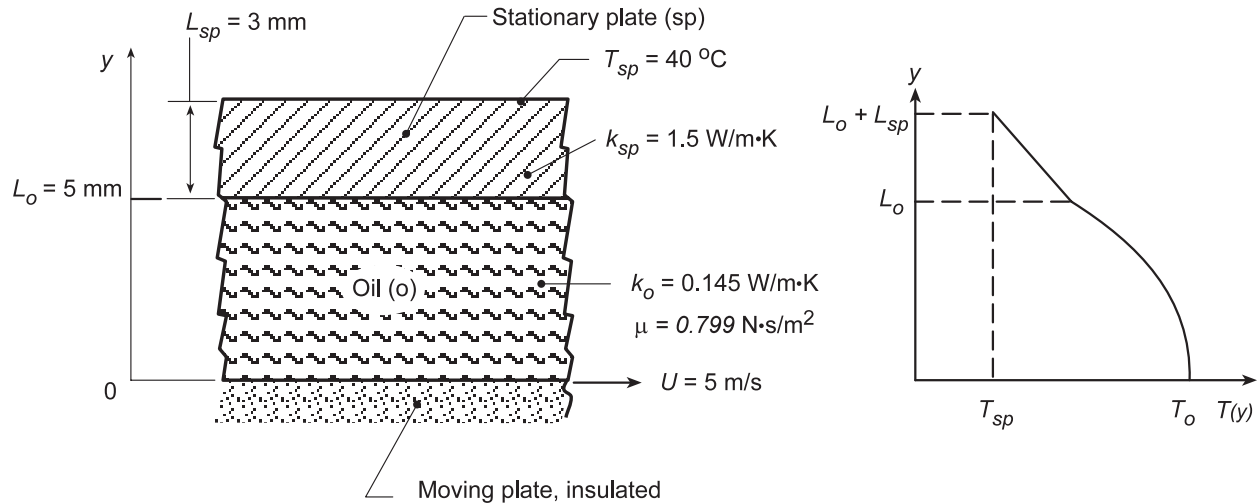

**ASSUMPTIONS:** (1) Steady-state conditions, (2) Fully developed Couette flow and (3) Incompressible fluid with constant properties.

**ANALYSIS:** (a) The temperature distribution is shown above with these key features: linear in plate, parabolic in oil film, discontinuity in slope at plate-oil interface, and zero gradient at lower plate surface.

(b) From Example 6S.1, the general solution to the conservation equations for the temperature distribution in the oil film is

$$T_o(y) = -Ay^2 + C_3y + C_4 \quad \text{where} \quad A = \frac{\mu}{2k_o} \left( \frac{U}{L_o} \right)^2$$

and the boundary conditions are,

$$\text{At } y = 0, \text{ insulated boundary} \quad \left. \frac{dT_o}{dy} \right|_{y=0} = 0; \quad C_3 = 0$$

$$\text{At } y = L_o, \text{ heat fluxes in oil and plate are equal,} \quad q_o''(L_o) = q_{sp}''(L_o)$$

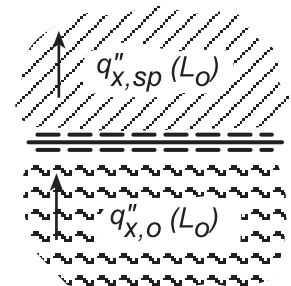

Continued...



**PROBLEM 6S.7 (Cont.)**

$$-k_o \left. \frac{dT_o}{dy} \right|_{y=L_o} = \frac{T_o(L_o) - T_{sp}}{R_{sp}} \quad \left\{ \begin{array}{l} \left. \frac{dT_o}{dy} \right|_{y=L_o} = -2AL_o \\ R_{sp} = L_{sp}/k_{sp} \end{array} \right. \quad T_o(L_o) = -AL_o^2 + C_4$$

$$C_4 = T_{sp} + AL_o^2 \left[ 1 + 2 \frac{k_o}{L_o} \frac{L_{sp}}{k_{sp}} \right]$$

Hence, the temperature distribution at the lower surface is

$$T_o(0) = -A \cdot 0 + C_4$$

$$T_o(0) = T_{sp} + \frac{\mu}{2k_o} U^2 \left[ 1 + 2 \frac{k_o}{L_o} \frac{L_{sp}}{k_{sp}} \right] \quad <$$

Substituting numerical values, find

$$T_o(0) = 40^\circ\text{C} + \frac{0.799 \text{ N}\cdot\text{s}/\text{m}^2}{2 \times 0.145 \text{ W}/\text{m}\cdot\text{K}} (5 \text{ m/s})^2 \left[ 1 + 2 \frac{0.145}{5} \times \frac{3}{1.5} \right] = 116.9^\circ\text{C} \quad <$$

**COMMENTS:** (1) Give a physical explanation about why the maximum temperature occurs at the lower surface.

(2) Sketch the temperature distribution if the upper plate moved with a speed  $U$  while the lower plate is stationary and all other conditions remain the same.

## PROBLEM 6S.8

**KNOWN:** Shaft of diameter 100 mm rotating at 9000 rpm in a journal bearing of 70 mm length. Uniform gap of 1 mm separates the shaft and bearing filled with lubricant. Outer surface of bearing is water-cooled and maintained at  $T_{wc} = 30^\circ\text{C}$ .

**FIND:** (a) Viscous dissipation in the lubricant,  $\mu\Phi(\text{W}/\text{m}^3)$ , (b) Heat transfer rate from the lubricant, assuming no heat lost through the shaft, and (c) Temperatures of the bearing and shaft,  $T_b$  and  $T_s$ .

**SCHEMATIC:**

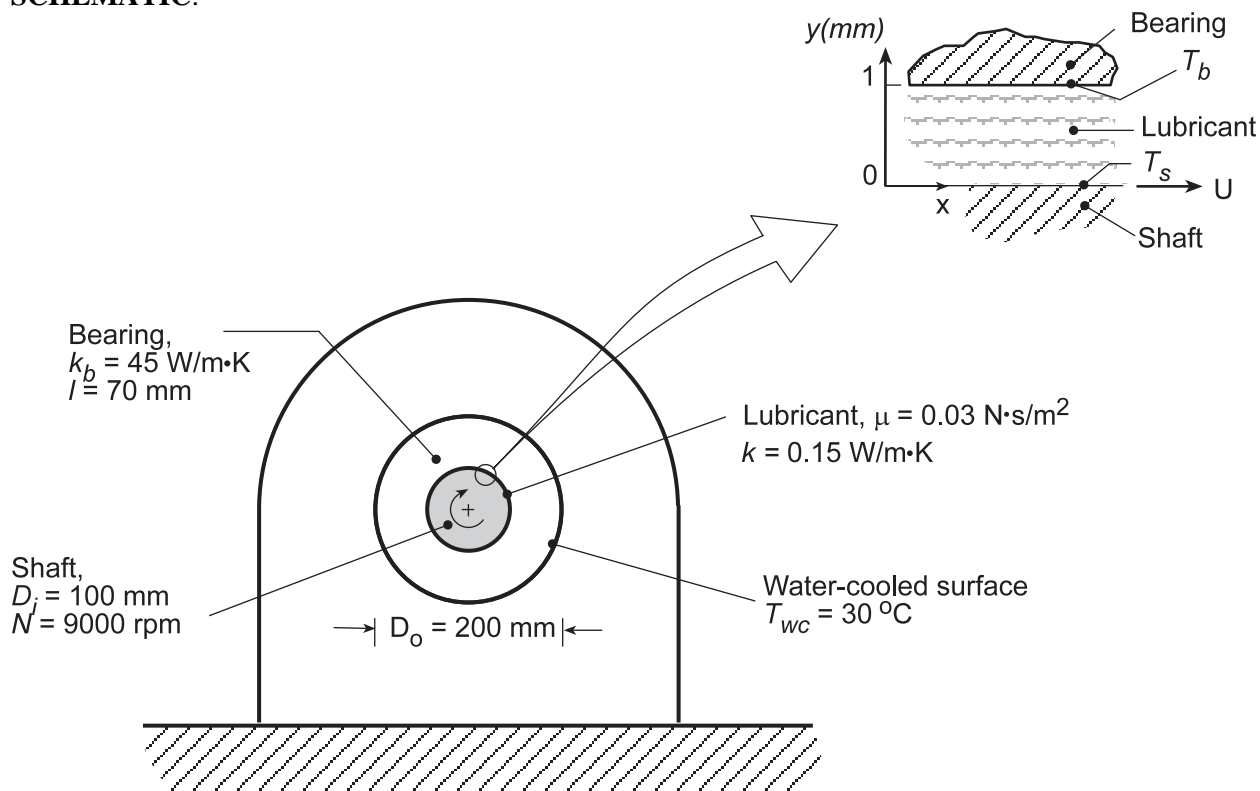

**ASSUMPTIONS:** (1) Steady-state conditions, (2) Fully developed Couette flow, (3) Incompressible fluid with constant properties, and (4) Negligible heat lost through the shaft.

**ANALYSIS:** (a) The viscous dissipation,  $\mu\Phi$ , Eq. 6S.20, for Couette flow from Example 6S.1, is

$$\mu\Phi = \mu \left( \frac{du}{dy} \right)^2 = \mu \left( \frac{U}{L} \right)^2 = 0.03 \text{ N}\cdot\text{s}/\text{m}^2 \left( \frac{47.1 \text{ m/s}}{0.001 \text{ m}} \right)^2 = 6.656 \times 10^7 \text{ W}/\text{m}^3 \quad <$$

where the velocity distribution is linear and the tangential velocity of the shaft is

$$U = \pi DN = \pi (0.100 \text{ m}) \times 9000 \text{ rpm} \times (\text{min}/60\text{s}) = 47.1 \text{ m/s}.$$

(b) The heat transfer rate from the lubricant volume  $\forall$  through the bearing is

$$q = \mu\Phi \cdot \forall = \mu\Phi (\pi D \cdot L \cdot \ell) = 6.65 \times 10^7 \text{ W}/\text{m}^3 (\pi \times 0.100 \text{ m} \times 0.001 \text{ m} \times 0.070 \text{ m}) = 1462 \text{ W} \quad <$$

where  $\ell = 70 \text{ mm}$  is the length of the bearing normal to the page.

Continued...

### PROBLEM 6S.8 (Cont.)

(c) From Fourier's law, the heat rate through the bearing material of inner and outer diameters,  $D_i$  and  $D_o$ , and thermal conductivity  $k_b$  is, from Eq. (3.32),

$$q_r = \frac{2\pi\ell k_b (T_b - T_{wc})}{\ln(D_o/D_i)}$$

$$T_b = T_{wc} + \frac{q_r \ln(D_o/D_i)}{2\pi\ell k_b}$$

$$T_b = 30^\circ\text{C} + \frac{1462\text{ W} \ln(200/100)}{2\pi \times 0.070\text{ m} \times 45\text{ W/m}\cdot\text{K}} = 81.2^\circ\text{C} \quad <$$

To determine the temperature of the shaft,  $T(0) = T_s$ , first the temperature distribution must be found beginning with the general solution, Example 6S.1,

$$T(y) = -\frac{\mu}{2k} \left(\frac{U}{L}\right)^2 y^2 + C_3 y + C_4$$

The boundary conditions are, at  $y = 0$ , the surface is adiabatic

$$\left. \frac{dT}{dy} \right|_{y=0} = 0 \quad C_3 = 0$$

and at  $y = L$ , the temperature is that of the bearing,  $T_b$

$$T(L) = T_b = -\frac{\mu}{2k} \left(\frac{U}{L}\right)^2 L^2 + 0 + C_4 \quad C_4 = T_b + \frac{\mu}{2k} U^2$$

Hence, the temperature distribution is

$$T(y) = T_b + \frac{\mu}{2k} U^2 \left(1 - \frac{y^2}{L^2}\right)$$

and the temperature at the shaft,  $y = 0$ , is

$$T_s = T(0) = T_b + \frac{\mu}{2k} U^2 = 81.3^\circ\text{C} + \frac{0.03\text{ N}\cdot\text{s}/\text{m}^2}{2 \times 0.15\text{ W/m}\cdot\text{K}} (47.1\text{ m/s})^2 = 303^\circ\text{C} \quad <$$

## PROBLEM 6S.9

**KNOWN:** Couette flow with heat transfer.

**FIND:** (a) Dimensionless form of temperature distribution, (b) Conditions for which top plate is adiabatic, (c) Expression for heat transfer to lower plate when top plate is adiabatic.

**SCHEMATIC:**

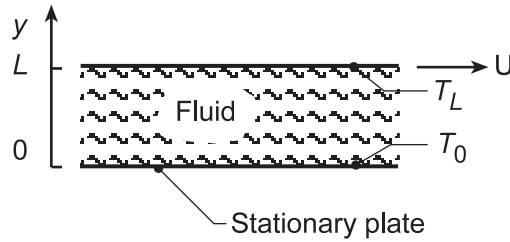

**ASSUMPTIONS:** (1) Steady-state conditions, (2) incompressible fluid with constant properties, (3) Negligible body forces, (4) Couette flow.

**ANALYSIS:** (a) From Example 6.4, the temperature distribution is

$$T = T_0 + \frac{\mu}{2k} U^2 \left[ \frac{y}{L} - \left( \frac{y}{L} \right)^2 \right] + (T_L - T_0) \frac{y}{L}$$

$$\frac{T - T_0}{T_L - T_0} = \frac{\mu U^2}{2k(T_L - T_0)} \left[ \frac{y}{L} - \left( \frac{y}{L} \right)^2 \right] + \frac{y}{L}$$

or, with

$$\theta \equiv (T - T_0)/(T_L - T_0), \quad \eta \equiv y/L,$$

$$\text{Pr} \equiv c_p \mu / k, \quad \text{Ec} \equiv U^2 / c_p (T_L - T_0)$$

$$\theta = \frac{\text{Pr} \cdot \text{Ec}}{2} (\eta - \eta^2) + \eta = \eta \left[ 1 + \frac{1}{2} \text{Pr} \cdot \text{Ec} (1 - \eta) \right] \quad (1) <$$

(b) For there to be zero heat transfer at the top plate,  $(dT/dy)_{y=L} = 0$ . Hence,  $(d\theta/d\eta)_{\eta=1} = 0$ .

$$\left. \frac{d\theta}{d\eta} \right|_{\eta=1} = \frac{\text{Pr} \cdot \text{Ec}}{2} (1 - 2\eta) \Big|_{\eta=1} + 1 = -\frac{\text{Pr} \cdot \text{Ec}}{2} + 1 = 0$$

There is no heat transfer at the top plate if,

$$\text{Ec} \cdot \text{Pr} = 2. \quad (2) <$$

(c) The heat transfer rate to the lower plate (per unit area) is

$$q_0'' = -k \left. \frac{dT}{dy} \right|_{y=0} = -k \frac{(T_L - T_0)}{L} \left. \frac{d\theta}{d\eta} \right|_{\eta=0}$$

$$q_0'' = -k \frac{T_L - T_0}{L} \left[ \frac{\text{Pr} \cdot \text{Ec}}{2} (1 - 2\eta) \Big|_{\eta=0} + 1 \right]$$

$$q_0'' = -k \frac{T_L - T_0}{L} \left( \frac{\text{Pr} \cdot \text{Ec}}{2} + 1 \right) = -2k (T_L - T_0) / L \quad <$$

Continued...

### PROBLEM 6S.9 (Cont.)

(d) Using Eq. (1), the dimensionless temperature distribution is plotted as a function of dimensionless distance,  $\eta = y/L$ . When  $Pr \cdot Ec = 0$ , there is no dissipation and the temperature distribution is linear, so that heat transfer is by conduction only. As  $Pr \cdot Ec$  increases, viscous dissipation becomes more important. When  $Pr \cdot Ec = 2$ , heat transfer to the upper plate is zero. When  $Pr \cdot Ec > 2$ , the heat rate is out of the oil film at both surfaces.

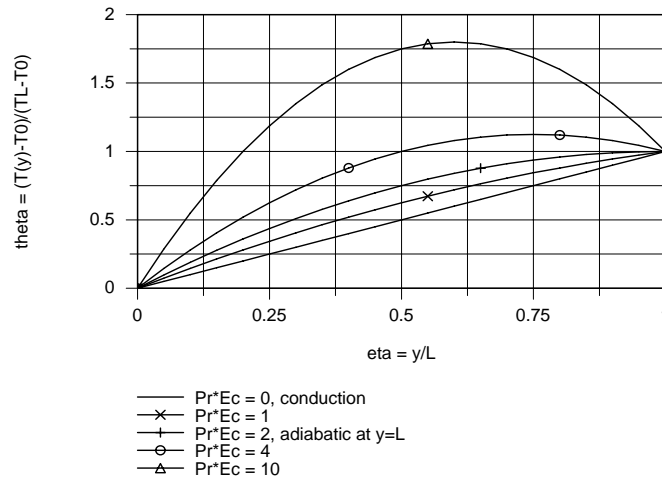

## PROBLEM 6S.10

**KNOWN:** Steady, incompressible, laminar flow between infinite parallel plates at different temperatures.

**FIND:** (a) Form of continuity equation, (b) Form of momentum equations and velocity profile. Relationship of pressure gradient to maximum velocity, (c) Form of energy equation and temperature distribution. Heat flux at top surface.

**SCHEMATIC:**

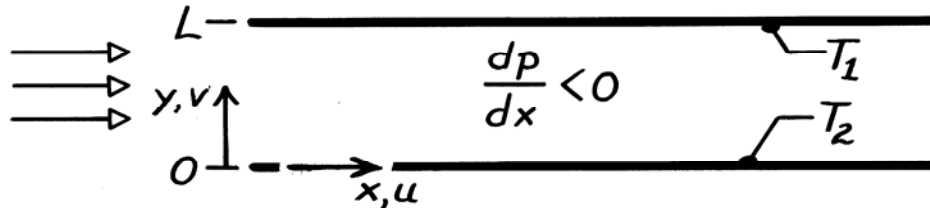

**ASSUMPTIONS:** (1) Two-dimensional flow (no variations in  $z$ ) between infinite, parallel plates, (2) Negligible body forces, (3) No internal energy generation, (4) Incompressible fluid with constant properties.

**ANALYSIS:** (a) For two-dimensional, steady conditions, the continuity equation is

$$\frac{\partial(\rho u)}{\partial x} + \frac{\partial(\rho v)}{\partial y} = 0.$$

Hence, for an incompressible fluid (constant  $\rho$ ) in parallel flow ( $v = 0$ ),

$$\frac{\partial u}{\partial x} = 0. \quad <$$

The flow is fully developed in the sense that, irrespective of  $y$ ,  $u$  is independent of  $x$ .

(b) With the above result and the prescribed conditions, the momentum equations reduce to

$$0 = -\frac{\partial p}{\partial x} + \mu \frac{\partial^2 u}{\partial y^2} \quad 0 = -\frac{\partial p}{\partial y} \quad <$$

Since  $p$  is independent of  $y$ ,  $\partial p / \partial x = dp / dx$  is independent of  $y$  and

$$\mu \frac{\partial^2 u}{\partial y^2} = \mu \frac{d^2 u}{dy^2} = \frac{dp}{dx}.$$

Since the left-hand side can, at most, depend only on  $y$  and the right-hand side is independent of  $y$ , both sides must equal the same constant  $C$ . That is,

$$\mu \frac{d^2 u}{dy^2} = C.$$

Hence, the velocity distribution has the form

$$u(y) = \frac{C}{2\mu} y^2 + C_1 y + C_2.$$

Using the boundary conditions to evaluate the constants,

$$u(0) = 0 \quad \rightarrow \quad C_2 = 0 \quad \text{and} \quad u(L) = 0 \quad \rightarrow \quad C_1 = -CL/2\mu.$$

Continued .....

**PROBLEM 6S.10 (Cont.)**

The velocity profile is  $u(y) = \frac{C}{2\mu}(y^2 - Ly)$ .

The profile is symmetric about the midplane, in which case the maximum velocity exists at  $y = L/2$ . Hence,

$$u(L/2) = u_{\max} = \frac{C}{2\mu} \left[ -\frac{L^2}{4} \right] \quad \text{or} \quad u_{\max} = -\frac{L^2}{8\mu} \frac{dp}{dx}. \quad <$$

(c) For fully developed thermal conditions,  $(\partial T/\partial x) = 0$  and temperature depends only on  $y$ . Hence with  $v = 0$ ,  $\partial u/\partial x = 0$ , and the prescribed assumptions, the energy equation becomes

$$\rho u \frac{\partial i}{\partial x} = k \frac{d^2 T}{dy^2} + u \frac{dp}{dx} + \mu \left[ \frac{du}{dy} \right]^2.$$

With  $i = e + p/\rho$ ,  $\frac{\partial i}{\partial x} = \frac{\partial e}{\partial x} + \frac{1}{\rho} \frac{dp}{dx}$  where  $\frac{\partial e}{\partial x} = \frac{\partial e}{\partial T} \frac{\partial T}{\partial x} + \frac{\partial e}{\partial \rho} \frac{\partial \rho}{\partial x} = 0$ .

Hence, the energy equation becomes  $0 = k \frac{d^2 T}{dy^2} + \mu \left[ \frac{du}{dy} \right]^2$ . <

With  $du/dy = (C/2\mu)(2y - L)$ , it follows that

$$\frac{d^2 T}{dy^2} = -\frac{C^2}{4k\mu} (4y^2 - 4Ly + L^2).$$

Integrating twice,

$$T(y) = -\frac{C^2}{4k\mu} \left[ \frac{y^4}{3} - \frac{2Ly^3}{3} + \frac{L^2 y^2}{2} \right] + C_3 y + C_4$$

Using the boundary conditions to evaluate the constants,

$$T(0) = T_2 \quad \rightarrow \quad C_4 = T_2 \quad \text{and} \quad T(L) = T_1 \quad \rightarrow \quad C_3 = \frac{C^2 L^3}{24k\mu} + \frac{(T_1 - T_2)}{L}.$$

Hence,  $T(y) = T_2 + \left[ \frac{y}{L} \right] (T_1 - T_2) - \frac{C^2}{4k\mu} \left[ \frac{y^4}{3} - \frac{2Ly^3}{3} + \frac{L^2 y^2}{2} - \frac{L^3 y}{6} \right]$ . <

From Fourier's law,

$$q''(L) = -k \left. \frac{\partial T}{\partial y} \right|_{y=L} = \frac{k}{L} (T_2 - T_1) + \frac{C^2}{4\mu} \left[ \frac{4}{3} L^3 - 2L^3 + L^3 - \frac{L^3}{6} \right]$$

$$q''(L) = \frac{k}{L} (T_2 - T_1) + \frac{C^2 L^3}{24\mu}. \quad <$$

**COMMENTS:** The third and second terms on the right-hand sides of the temperature distribution and heat flux, respectively, represents the effects of viscous dissipation. If  $C$  is large (due to large  $\mu$  or  $u_{\max}$ ), viscous dissipation is significant. If  $C$  is small, conduction effects dominate.

## PROBLEM 6S.11

**KNOWN:** Steady, incompressible flow of binary mixture between infinite parallel plates with different species concentrations.

**FIND:** Form of species continuity equation and concentration distribution. Species flux at upper surface.

**SCHEMATIC:**

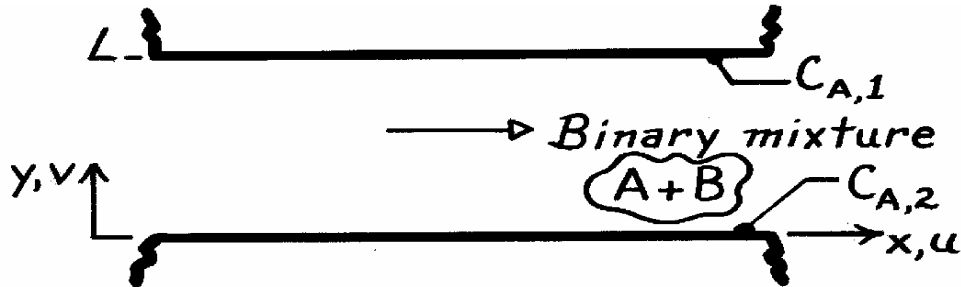

**ASSUMPTIONS:** (1) Two-dimensional flow, (2) No chemical reactions, (3) Constant properties.

**ANALYSIS:** For fully developed conditions,  $\partial C_A / \partial x = 0$ . Hence with  $v = 0$ , the species conservation equation reduces to

$$\frac{d^2 C_A}{dy^2} = 0. \quad <$$

Integrating twice, the general form of the species concentration distribution is

$$C_A(y) = C_1 y + C_2.$$

Using appropriate boundary conditions and evaluating the constants,

$$\begin{aligned} C_A(0) = C_{A,2} &\rightarrow C_2 = C_{A,2} \\ C_A(L) = C_{A,1} &\rightarrow C_1 = (C_{A,1} - C_{A,2})/L, \end{aligned}$$

the concentration distribution is

$$C_A(y) = C_{A,2} + (y/L) (C_{A,1} - C_{A,2}). \quad <$$

From Fick's law, the species flux is

$$\begin{aligned} N_A''(L) &= -D_{AB} \left. \frac{dC_A}{dy} \right|_{y=L} \\ N_A''(L) &= \frac{D_{AB}}{L} (C_{A,2} - C_{A,1}). \quad < \end{aligned}$$

**COMMENTS:** An analogy between heat and mass transfer exists if viscous dissipation is negligible. The energy equation is then  $d^2 T / dy^2 = 0$ . Hence, both heat and species transfer are influenced only by diffusion. Expressions for  $T(y)$  and  $q''(L)$  are analogous to those for  $C_A(y)$  and  $N_A''(L)$ .



## PROBLEM 6S.12

**KNOWN:** Flow conditions between two parallel plates, across which vapor transfer occurs.

**FIND:** (a) Variation of vapor molar concentration between the plates and mass rate of water production per unit area, (b) Heat required to sustain the process.

**SCHEMATIC:**

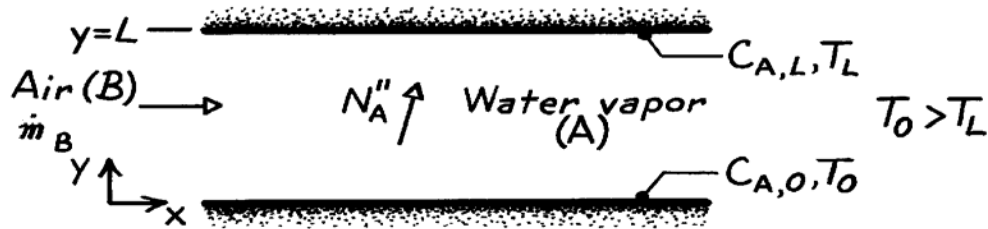

**ASSUMPTIONS:** (1) Steady-state conditions, (2) Fully developed, incompressible flow with constant properties, (3) Negligible body forces, (4) No chemical reactions, (5) All work interactions, including viscous dissipation, are negligible.

**ANALYSIS:** (a) The flow will be fully developed in terms of the vapor concentration field, as well as the velocity and temperature fields. Hence

$$\frac{\partial C_A}{\partial x} = 0 \quad \text{or} \quad C_A(x, y) = C_A(y).$$

Also, with  $\partial C_A / \partial t = 0$ ,  $\dot{N}_A = 0$ ,  $v = 0$  and constant  $D_{AB}$ , the species conservation equation reduces to

$$\frac{d^2 C_A}{dy^2} = 0.$$

Separating and integrating twice,

$$C_A(y) = C_1(y) + C_2.$$

Applying the boundary conditions,

$$\begin{aligned} C_A(0) = C_{A,0} &\quad \rightarrow \quad C_2 = C_{A,0} \\ C_A(L) = C_{A,L} &\quad \rightarrow \quad C_{A,L} = C_1 L + C_2 \quad \quad C_1 = -\frac{C_{A,0} - C_{A,L}}{L} \end{aligned}$$

find the species concentration distribution,

$$C_A(y) = C_{A,0} - (C_{A,0} - C_{A,L}) (y/L). \quad <$$

From Fick's law, Eq. 6.7, the species transfer rate is

$$N_A'' = N_{A,s}'' = -D_{AB} \left. \frac{\partial C_A}{\partial y} \right]_{y=0} = D_{AB} \frac{C_{A,0} - C_{A,L}}{L}.$$

Continued .....

**PROBLEM 6S.12 (Cont.)**

Multiplying by the molecular weight of water vapor,  $\mathcal{M}_A$ , the mass rate of water production per unit area is

$$n''_A = \mathcal{M}_A N''_A = \mathcal{M}_A D_{AB} \frac{C_{A,0} - C_{A,L}}{L}. \quad <$$

(b) Heat must be supplied to the bottom surface in an amount equal to the latent and sensible heat transfer from the surface,

$$q'' = q''_{\text{lat}} + q''_{\text{sen}}$$

$$q'' = n''_{A,s} h_{fg} + \left[ -k \frac{dT}{dy} \right]_{y=0}.$$

The temperature distribution may be obtained by solving the energy equation, which, for the prescribed conditions, reduces to

$$\frac{d^2T}{dy^2} = 0.$$

Separating and integrating twice,

$$T(y) = C_1 y + C_2.$$

Applying the boundary conditions,

$$\begin{aligned} T(0) = T_0 &\quad \rightarrow \quad C_2 = T_0 \\ T(L) = T_L &\quad \rightarrow \quad C_1 = (T_1 - T_0)/L \end{aligned}$$

find the temperature distribution,

$$T(y) = T_0 - (T_0 - T_L) y/L.$$

Hence,

$$\left[ -k \frac{dT}{dy} \right]_{y=0} = k \frac{(T_0 - T_L)}{L}.$$

Accordingly,

$$q'' = \mathcal{M}_A D_{AB} \frac{C_{A,0} - C_{A,L}}{L} h_{fg} + k \frac{(T_0 - T_L)}{L}. \quad <$$

**COMMENTS:** Despite the existence of the flow, species and energy transfer across the air are uninfluenced by advection and transfer is only by diffusion. If the flow were not fully developed, advection would have a significant influence on the species concentration and temperature fields and hence on the rate of species and energy transfer. The foregoing results would, of course, apply in the case of no air flow. The physical condition is an example of Poiseuille flow with heat and mass transfer.

### PROBLEM 6S.13

**KNOWN:** The conservation equations, Eqs. 6S.24 and 6S.31.

**FIND:** (a) Describe physical significance of terms in these equations, (b) Identify approximations and special conditions used to reduce these equations to the boundary layer equations, Eqs. 6.29 and 6.30, (c) Identify the conditions under which these two boundary layer equations have the same form and, hence, an analogy will exist.

**ANALYSIS:** (a) The energy conservation equation, Eq. 6S.24, has the form

$$\rho u \frac{\partial i}{\partial x} + \rho v \frac{\partial i}{\partial y} = \frac{\partial}{\partial x} \left[ k \frac{\partial T}{\partial x} \right] + \frac{\partial}{\partial y} \left[ k \frac{\partial T}{\partial y} \right] + \left[ u \frac{\partial p}{\partial x} + v \frac{\partial p}{\partial y} \right] + \mu \Phi + \dot{q}.$$

1a
1b
2a
2b
3
4
5

The terms, as identified, have the following physical significance:

1. Change of enthalpy (thermal + flow work) advected in x and y directions, <
2. Change of conduction flux in x and y directions,
3. Work done by static pressure forces,
4. Work done by viscous stresses,
5. Rate of energy generation.

The species mass conservation equation for a constant total concentration has the form

$$u \frac{\partial C_A}{\partial x} + v \frac{\partial C_A}{\partial y} = \frac{\partial}{\partial x} \left[ D_{AB} \frac{\partial C_A}{\partial x} \right] + \frac{\partial}{\partial y} \left[ D_{AB} \frac{\partial C_A}{\partial y} \right] + \dot{N}_A$$

1a
1b
2a
2b
3

1. Change in species transport due to advection in x and y directions, <
2. Change in species transport by diffusion in x and y directions, and
3. Rate of species generation.

(b) The special conditions used to reduce the above equations to the boundary layer equations are: *constant properties, incompressible flow, non-reacting species* ( $\dot{N}_A = 0$ ), *without internal heat generation* ( $\dot{q} = 0$ ), *species diffusion has negligible effect on the thermal boundary layer,  $u(\partial p / \partial x)$  is negligible.* The approximations are,

Velocity boundary layer  $\left\{ u \gg v \quad \frac{\partial u}{\partial y} \gg \frac{\partial u}{\partial x}, \frac{\partial v}{\partial y}, \frac{\partial v}{\partial x} \right.$

Thermal b.1.:  $\left\{ \frac{\partial T}{\partial y} \gg \frac{\partial T}{\partial x} \right.$       Concentration b.1.:  $\left\{ \frac{\partial C_A}{\partial y} \gg \frac{\partial C_A}{\partial x} \right.$

The resulting simplified boundary layer equations are

$$u \frac{\partial T}{\partial x} + v \frac{\partial T}{\partial y} = \alpha \frac{\partial^2 T}{\partial y^2} + \frac{v}{c} \left[ \frac{\partial u}{\partial y} \right]^2 \quad u \frac{\partial C_A}{\partial x} + v \frac{\partial C_A}{\partial y} = D_{AB} \frac{\partial^2 C_A}{\partial y^2}$$

1a
1b
2a
3
1c
1d
2b
<

where the terms are: 1. Advective transport, 2. Diffusion, and 3. Viscous dissipation.

(c) When viscous dissipation effects are negligible, the two boundary layer equations have identical form. If the boundary conditions for each equation are of the same form, an analogy between heat and mass (species) transfer exists.

### PROBLEM 6S.14

**KNOWN:** Thickness and inclination of a liquid film. Mass density of gas in solution at free surface of liquid.

**FIND:** (a) Liquid momentum equation and velocity distribution for the x-direction. Maximum velocity, (b) Continuity equation and density distribution of the gas in the liquid, (c) Expression for the local Sherwood number, (d) Total gas absorption rate for the film, (e) Mass rate of NH<sub>3</sub> removal by a water film for prescribed conditions.

**SCHEMATIC:**

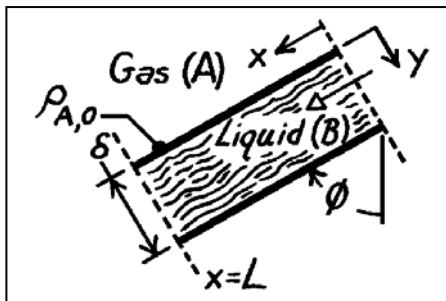

NH<sub>3</sub> (A) – Water (B)  
 $L = 2\text{m}$   
 $\delta = 1\text{mm}$   
 $D = 0.05\text{m}$   
 $W = \pi D = 0.157\text{m}$   
 $\rho_{A,0} = 25\text{kg/m}^3$   
 $D_{AB} = 2 \times 10^{-9}\text{m}^2/\text{s}$   
 $\phi = 0^\circ$

**ASSUMPTIONS:** (1) Steady-state conditions, (2) The film is in fully developed, laminar flow, (3) Negligible shear stress at the liquid-gas interface, (4) Constant properties, (5) Negligible gas concentration at  $x = 0$  and  $y = \delta$ , (6) No chemical reactions in the liquid, (7) Total mass density is constant, (8) Liquid may be approximated as semi-infinite to gas transport.

**PROPERTIES:** Table A-6, Water, liquid (300K):  $\rho_f = 1/v_f = 997\text{kg/m}^3$ ,  $\mu = 855 \times 10^{-6}\text{N}\cdot\text{s/m}^2$ ,  $\nu = \mu/\rho_f = 0.855 \times 10^{-6}\text{m}^2/\text{s}$ .

**ANALYSIS:** (a) For fully developed flow ( $v = w = 0$ ,  $\partial u/\partial x = 0$ ), the x-momentum equation is  
 $0 = \partial \tau_{yx} / \partial y + X$  where  $\tau_{yx} = \mu(\partial u / \partial y)$  and  $X = (\rho g) \cos \phi$ .

That is, the momentum equation reduces to a balance between gravitational and shear forces. Hence,

$$\mu \left( \partial^2 u / \partial y^2 \right) = -(\rho g) \cos \phi.$$

Integrating,  $\partial u / \partial y = -(g \cos \phi / \nu) y + C_1$        $u = -(g \cos \phi / 2\nu) y^2 + C_1 y + C_2$ .

Applying the boundary conditions,

$$\left. \partial u / \partial y \right|_{y=0} = 0 \quad \rightarrow \quad C_1 = 0$$

$$u(\delta) = 0 \quad \rightarrow \quad C_2 = g \cos \phi \frac{\delta^2}{2\nu}.$$

Hence, 
$$u = \frac{g \cos \phi}{2\nu} (\delta^2 - y^2) = \frac{g \cos \phi \delta^2}{2\nu} \left[ 1 - (y/\delta)^2 \right] \quad <$$

and the maximum velocity exists at  $y = 0$ ,

$$u_{\max} = u(0) = (g \cos \phi \delta^2) / 2\nu. \quad <$$

(b) Species transport within the liquid is influenced by diffusion in the y-direction and advection in the x-direction. Hence, the species continuity equation with  $u$  assumed equal to  $u_{\max}$  throughout the region of gas penetration is

Continued .....

**PROBLEM 6S.14 (Cont.)**

$$u \frac{\partial \rho_A}{\partial x} = D_{AB} \frac{\partial^2 \rho_A}{\partial y^2} \quad \frac{\partial^2 \rho_A}{\partial y^2} = \frac{u_{\max}}{D_{AB}} \frac{\partial \rho_A}{\partial x}$$

Appropriate boundary conditions are:  $\rho_A(x,0) = \rho_{A,o}$  and  $\rho_A(x,\infty) = 0$  and the entrance condition is:  $\rho_A(0,y) = 0$ . The problem is therefore analogous to transient conduction in a semi-infinite medium due to a sudden change in surface temperature. From Section 5.7, the solution is then

$$\frac{\rho_A - \rho_{A,o}}{0 - \rho_{A,o}} = \operatorname{erf} \frac{y}{2(D_{AB}x/u_{\max})^{1/2}} \quad \rho_A = \rho_{A,o} \operatorname{erfc} \frac{y}{2(D_{AB}x/u_{\max})^{1/2}} <$$

(c) The Sherwood number is defined as

$$\operatorname{Sh}_x = \frac{h_{m,x} x}{D_{AB}} \quad \text{where} \quad h_{m,x} \equiv \frac{n''_{A,x}}{\rho_{A,o}} = \frac{-D_{AB} \partial \rho_A / \partial y|_{y=0}}{\rho_{A,o}}$$

$$\left. \frac{\partial \rho_A}{\partial y} \right|_{y=0} = -\rho_{A,o} \frac{2}{(\pi)^{1/2}} \exp \left[ -\frac{y^2 u_{\max}}{4 D_{AB} x} \right] \frac{1}{2(D_{AB}x/u_{\max})^{1/2}} \bigg|_{y=0} = -\rho_{A,o} \left[ \frac{u_{\max}}{\pi D_{AB} x} \right]^{1/2}$$

Hence,

$$h_{m,x} = \left[ \frac{u_{\max} D_{AB}}{\pi x} \right]^{1/2} \quad \operatorname{Sh}_x = \frac{1}{(\pi)^{1/2}} \left[ \frac{u_{\max} x}{D_{AB}} \right]^{1/2} = \frac{1}{(\pi)^{1/2}} \left[ \frac{u_{\max} x}{\nu} \right]^{1/2} \left[ \frac{\nu}{D_{AB}} \right]^{1/2}$$

and with  $\operatorname{Re}_x \equiv u_{\max} x/\nu$ ,

$$\operatorname{Sh}_x = \left[ 1/(\pi)^{1/2} \right] \operatorname{Re}_x^{1/2} \operatorname{Sc}^{1/2} = 0.564 \operatorname{Re}_x^{1/2} \operatorname{Sc}^{1/2} <$$

(d) The total gas absorption rate may be expressed as

$$n_A = \bar{h}_{m,x} (W \cdot L) \rho_{A,o}$$

where the average mass transfer convection coefficient is

$$\bar{h}_{m,x} = \frac{1}{L} \int_0^L h_{m,x} dx = \frac{1}{L} \left[ \frac{u_{\max} D_{AB}}{\pi} \right]^{1/2} \int_0^L \frac{dx}{x^{1/2}} = \left[ \frac{4u_{\max} D_{AB}}{\pi L} \right]^{1/2}$$

Hence, the absorption rate per unit width is

$$n_A / W = (4u_{\max} D_{AB} L / \pi)^{1/2} \rho_{A,o} <$$

(e) From the foregoing results, it follows that the ammonia absorption rate is

$$n_A = \left[ \frac{4u_{\max} D_{AB} L}{\pi} \right]^{1/2} W \rho_{A,o} = \left[ \frac{4 g \cos \phi \delta^2 D_{AB} L}{2\pi \nu} \right]^{1/2} W \rho_{A,o}$$

Substituting numerical values,

$$n_A = \left[ \frac{4 \times 9.8 \text{ m/s}^2 \times 1 \times (10^{-3} \text{ m})^2 (2 \times 10^{-9} \text{ m}^2/\text{s}) 2\text{m}}{2\pi \times 0.855 \times 10^{-6} \text{ m}^2/\text{s}} \right]^{1/2} (0.157 \text{ m}) 25 \text{ kg/m}^3 = 6.71 \times 10^{-4} \text{ kg/s} <$$

**COMMENTS:** Note that  $\rho_{A,o} \neq \rho_{A,\infty}$ , where  $\rho_{A,\infty}$  is the mass density of the gas phase. The value of  $\rho_{A,o}$  depends upon the pressure of the gas and the solubility of the gas in the liquid.

## PROBLEM 11S.1

**KNOWN:** Operating conditions and surface area of a finned-tube, cross-flow exchanger.

**FIND:** Overall heat transfer coefficient.

**SCHEMATIC:**

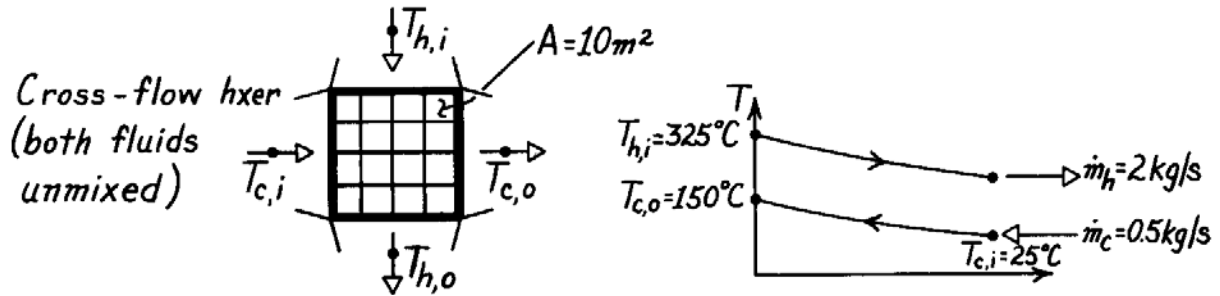

**ASSUMPTIONS:** (1) Negligible heat loss to surroundings, (2) Constant properties, (3) Exhaust gas properties are those of air.

**PROPERTIES:** Table A-6, Water ( $\bar{T}_m = 87^\circ\text{C}$ ):  $\bar{c}_p = 4203 \text{ J/kg}\cdot\text{K}$ ; Table A-4, Air ( $T_m \approx 275^\circ\text{C}$ ):  $\bar{c}_p = 1040 \text{ J/kg}\cdot\text{K}$ .

**ANALYSIS:** From the energy balance equations

$$q = \dot{m}_c c_{p,c} (T_{c,o} - T_{c,i}) = 0.5 \text{ kg/s} \times 4203 \text{ J/kg}\cdot\text{K} (150 - 25)^\circ\text{C} = 2.63 \times 10^5 \text{ W}$$

$$T_{h,o} = T_{h,i} - \frac{q}{\dot{m}_h c_{p,h}} = 325^\circ\text{C} - \frac{2.63 \times 10^5 \text{ W}}{2 \text{ kg/s} \times 1040 \text{ J/kg}\cdot\text{K}} = 198.6^\circ\text{C}.$$

Hence

$$U = q / A \Delta T_{\ell m} \quad \text{where} \quad \Delta T_{\ell m} = F \Delta T_{\ell m, \text{CF}}.$$

From Fig. 11S.3, with

$$P = \frac{t_o - t_i}{T_i - t_i} = \frac{150 - 25}{325 - 25} = 0.42, \quad R = \frac{T_i - T_o}{t_o - t_i} = \frac{325 - 198.6}{150 - 25} = 1.01, \quad F = 0.94$$

$$\Delta T_{\ell m, \text{CF}} = \frac{(325 - 150) - (198.6 - 25)}{\ln \frac{325 - 150}{198.6 - 25}} = 174.3^\circ\text{C}.$$

Hence

$$U = \frac{q}{A F \Delta T_{\ell m, \text{CF}}} = \frac{2.63 \times 10^5 \text{ W}}{10 \text{ m}^2 \times 0.94 \times 174.3^\circ\text{C}} = 160 \text{ W/m}^2 \cdot \text{K}. \quad <$$

**COMMENTS:** From the  $\varepsilon$ -NTU method,  $C_c = 2102 \text{ W/K}$ ,  $C_h = 2080 \text{ W/K}$ ,  $(C_{\min}/C_{\max}) \approx 1$ ,  $q_{\max} = 6.24 \times 10^5 \text{ W}$  and  $\varepsilon = 0.42$ . Hence, from Fig. 11.14,  $\text{NTU} \approx 0.75$  and  $U \approx 156 \text{ W/m}^2 \cdot \text{K}$ .

## PROBLEM 11S.2

**KNOWN:** Heat exchanger with two shell passes and eight tube passes having an area  $925\text{m}^2$ ;  $45,500\text{ kg/h}$  water is heated from  $80^\circ\text{C}$  to  $150^\circ\text{C}$ ; hot exhaust gases enter at  $350^\circ\text{C}$  and exit at  $175^\circ\text{C}$ .

**FIND:** Overall heat transfer coefficient.

**SCHEMATIC:**

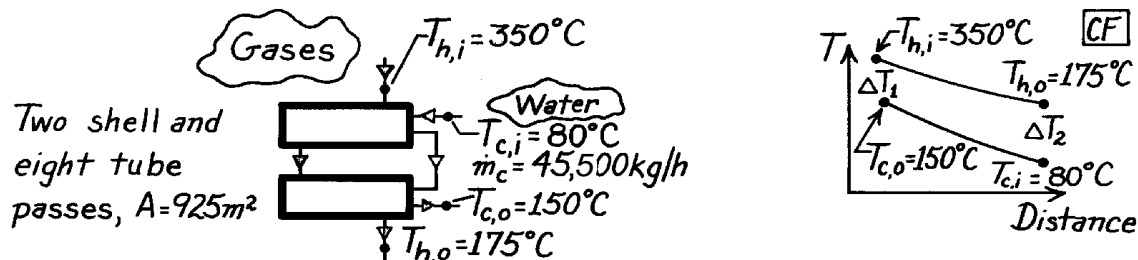

**ASSUMPTIONS:** (1) Negligible losses to surroundings, (2) Negligible kinetic and potential energy changes, (3) Constant properties, (4) Exhaust gas properties are approximated as those of atmospheric air.

**PROPERTIES:** Table A-6, Water ( $\bar{T}_c = (80 + 150)^\circ\text{C} / 2 = 388\text{K}$ ):  $c_c = c_{p,f} = 4236\text{ J/kg}\cdot\text{K}$ .

**ANALYSIS:** The overall heat transfer coefficient follows from Eqs. 11.9 and 11S.1 written in the form

$$U = q / AF\Delta T_{\ell m,CF}$$

where  $F$  is the correction factor for the HXer configuration, Fig. 11S.2, and  $\Delta T_{\ell m,CF}$  is the log mean temperature difference (CF), Eqs. 11.15 and 11.16. From Fig. 11S.2, find

$$R = \frac{T_{h,i} - T_{h,o}}{T_{c,o} - T_{c,i}} = \frac{(350 - 175)^\circ\text{C}}{(150 - 80)^\circ\text{C}} = 2.5 \quad P = \frac{T_{c,o} - T_{c,i}}{T_{h,i} - T_{c,i}} = \frac{(150 - 80)^\circ\text{C}}{(350 - 80)^\circ\text{C}} = 0.26$$

find  $F \approx 0.97$ . The log-mean temperature difference, Eqs. 11.15 and 11.17, is

$$\Delta T_{\ell m,CF} = \frac{\Delta T_1 - \Delta T_2}{\ln(\Delta T_1 / \Delta T_2)} = \frac{(350 - 150)^\circ\text{C} - (175 - 80)^\circ\text{C}}{\ln[(350 - 150) / (175 - 80)]} = 141.1^\circ\text{C}.$$

From an overall energy balance on the cold fluid (water), the heat rate is

$$q = \dot{m}_c c_c (T_{c,o} - T_{c,i})$$

$$q = 45,500\text{ kg/h} \times 1\text{h} / 3600\text{s} \times 4236\text{ J/kg}\cdot\text{K} (150 - 80)^\circ\text{C} = 3.748 \times 10^6\text{ W}.$$

Substituting values with  $A = 925\text{ m}^2$ , find

$$U = 3.748 \times 10^6\text{ W} / 925\text{m}^2 \times 0.97 \times 141.1\text{K} = 29.6\text{ W/m}^2 \cdot \text{K}.$$

<

**COMMENTS:** Compare the above result with representative values for air-water exchangers, as given in Table 11.2. Note that in this exchanger, two shells with eight tube passes, the correction factor effect is very small, since  $F = 0.97$ .

### PROBLEM 11S.3

**KNOWN:** A shell and tube Hxer (two shells, four tube passes) heats 10,000 kg/h of pressurized water from 35°C to 120°C with 5,000 kg/h water entering at 300°C.

**FIND:** Required heat transfer area,  $A_S$ .

**SCHEMATIC:**

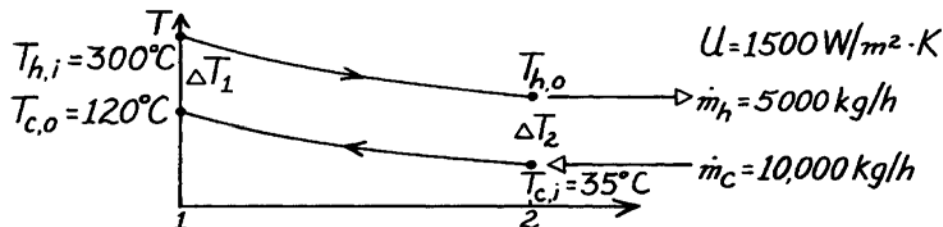

**ASSUMPTIONS:** (1) Negligible heat loss to surroundings, (2) Constant properties.

**PROPERTIES:** Table A-6, Water ( $\bar{T}_c = 350$  K):  $c_p = 4195$  J/kg·K; Table A-6, Water (Assume  $T_{h,o} \approx 150^\circ\text{C}$ ,  $\bar{T}_h \approx 500$  K):  $c_p = 4660$  J/kg·K.

**ANALYSIS:** The rate equation, Eq. 11.14, can be written in the form

$$A_S = q / U \Delta T_{\ell m} \quad (1)$$

and from Eq. 11S.1,

$$\Delta T_{\ell m} = F \Delta T_{\ell m, CF} \quad \text{where} \quad \Delta T_{\ell m, CF} = \frac{\Delta T_1 - \Delta T_2}{\ln(\Delta T_1 / \Delta T_2)}. \quad (2,3)$$

From an energy balance on the cold fluid, the heat rate is

$$q = \dot{m}_c c_{p,c} (T_{c,o} - T_{c,i}) = \frac{10,000 \text{ kg/h}}{3600 \text{ s/h}} \times 4195 \frac{\text{J}}{\text{kg} \cdot \text{K}} (120 - 35) \text{ K} = 9.905 \times 10^5 \text{ W}.$$

From an energy balance on the hot fluid, the outlet temperature is

$$T_{h,o} = T_{h,i} - q / \dot{m}_h c_{p,h} = 300^\circ\text{C} - 9.905 \times 10^5 \text{ W} / \frac{5000 \text{ kg}}{3600 \text{ s}} \times 4660 \frac{\text{J}}{\text{kg} \cdot \text{K}} = 147^\circ\text{C}.$$

From Fig. 11S.2, determine  $F$  from values of  $P$  and  $R$ , where  $P = (120 - 35)^\circ\text{C} / (300 - 35)^\circ\text{C} = 0.32$ ,  $R = (300 - 147)^\circ\text{C} / (120 - 35)^\circ\text{C} = 1.8$ , and  $F \approx 0.97$ . The log-mean temperature difference based upon a CF arrangement follows from Eq. (3); find

$$\Delta T_{\ell m} = [(300 - 120) - (147 - 35)] \text{ K} / \ln \frac{(300 - 120)}{(147 - 35)} = 143.3 \text{ K}.$$

$$A_S = 9.905 \times 10^5 \text{ W} / 1500 \text{ W/m}^2 \cdot \text{K} \times 0.97 \times 143.3 \text{ K} = 4.75 \text{ m}^2 \quad <$$

**COMMENTS:** (1) Check  $\bar{T}_h \approx 500$  K used in property determination;  $\bar{T}_h = (300 + 147)^\circ\text{C} / 2 = 497$  K.

(2) Using the NTU- $\varepsilon$  method, determine first the capacity rate ratio,  $C_{\min} / C_{\max} = 0.56$ . Then

$$\varepsilon \equiv \frac{q}{q_{\max}} = \frac{C_{\max} (T_{c,o} - T_{c,i})}{C_{\min} (T_{h,i} - T_{c,i})} = \frac{1}{0.56} \times \frac{(120 - 35)^\circ\text{C}}{(300 - 35)^\circ\text{C}} = 0.57.$$

From Fig. 11.13, find that  $\text{NTU} = AU / C_{\min} \approx 1.1$  giving  $A_S = 4.7 \text{ m}^2$ .



### PROBLEM 11S.4

**KNOWN:** The shell and tube Hxer (two shells, four tube passes) of Problem 11.14, known to have an area  $4.75\text{m}^2$ , provides  $95^\circ\text{C}$  water at the cold outlet (rather than  $120^\circ\text{C}$ ) after several years of operation. Flow rates and inlet temperatures of the fluids remain the same.

**FIND:** The fouling factor,  $R_f$ .

**SCHEMATIC:**

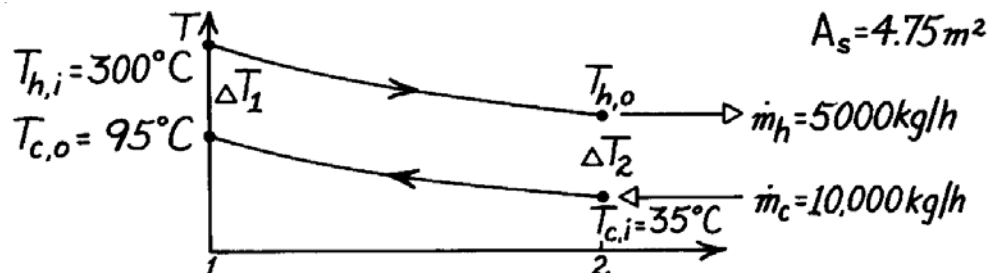

**ASSUMPTIONS:** (1) Negligible heat loss to surroundings, (2) Constant properties, (3) Thermal resistance for the clean condition is  $R_t'' = (1500\text{ W/m}^2 \cdot \text{K})^{-1}$ .

**PROPERTIES:** Table A-6, Water ( $\bar{T}_c \approx 338\text{ K}$ ):  $c_p = 4187\text{ J/kg} \cdot \text{K}$ ; Table A-6, Water (Assume  $T_{h,o} \approx 190^\circ\text{C}$ ,  $\bar{T}_h \approx 520\text{ K}$ ):  $c_p = 4840\text{ J/kg} \cdot \text{K}$ .

**ANALYSIS:** The overall heat transfer coefficient can be expressed as

$$U = 1/(R_t'' + R_f'') \quad \text{or} \quad R_f'' = 1/U - R_t'' \quad (1)$$

where  $R_t''$  is the thermal resistance for the clean condition and  $R_f''$ , the fouling factor, represents the additional resistance due to fouling of the surface. The rate equation, Eq. 11.14 with Eq. 11S.1, has the form,

$$U = q/A_s F \Delta T_{lm,CF} \quad \Delta T_{lm,CF} = (\Delta T_1 - \Delta T_2)/\ln(\Delta T_1/\Delta T_2). \quad (2)$$

From energy balances on the cold and hot fluids, find

$$q = \dot{m}_c c_{p,c} (T_{c,o} - T_{c,i}) = (10,000/3600\text{ kg/s}) 4187\text{ J/kg} \cdot \text{K} (95 - 35)\text{ K} = 6.978 \times 10^5\text{ W}$$

$$T_{h,o} = T_{h,i} - q/\dot{m}_h c_{p,h} = 300^\circ\text{C} - 6.978 \times 10^5\text{ W}/(5000/3600\text{ kg/s} \times 4840\text{ J/kg} \cdot \text{K}) = 196.2^\circ\text{C}.$$

The factor,  $F$ , follows from values of  $P$  and  $R$  as given by Fig. 11S.2 with

$$P = (95 - 35)/(300 - 35) = 0.23 \quad R = (300 - 196)/(120 - 35) = 1.22$$

giving  $F \approx 1$ . Based upon CF arrangement,

$$\Delta T_{lm,CF} = [(300 - 95) - (196 - 35)]^\circ\text{C}/\ln[(300 - 95)/(196 - 35)] = 182\text{ K}.$$

Using Eq. (2), find now the overall heat transfer coefficient as

$$U = 6.978 \times 10^5\text{ W}/4.75\text{m}^2 \times 1 \times 182\text{ K} = 806\text{ W/m}^2 \cdot \text{K}.$$

From Eq. (1), the fouling factor is

$$R_f'' = \frac{1}{806\text{ W/m}^2 \cdot \text{K}} - \frac{1}{1500\text{ W/m}^2 \cdot \text{K}} = 5.74 \times 10^{-4}\text{ m}^2 \cdot \text{K/W}. \quad \leftarrow$$

**COMMENTS:** Note that the effect of fouling is to nearly double ( $U_{\text{clean}}/U_{\text{fouled}} = 1500/806 \approx 1.9$ ) the resistance to heat transfer. Note also the assumption for  $T_{h,o}$  used for property evaluation is satisfactory.

## PROBLEM 11S.5

**KNOWN:** Flow rates and inlet temperatures for automobile radiator configured as a cross-flow heat exchanger with both fluids unmixed. Overall heat transfer coefficient.

**FIND:** (a) Area required to achieve hot fluid (water) outlet temperature,  $T_{h,o} = 330$  K, and (b) Outlet temperatures,  $T_{h,o}$  and  $T_{c,o}$ , as a function of the overall coefficient for the range,  $200 \leq U \leq 400$  W/m<sup>2</sup>·K with the surface area  $A$  found in part (a) with all other heat transfer conditions remaining the same as for part (a).

**SCHEMATIC:**

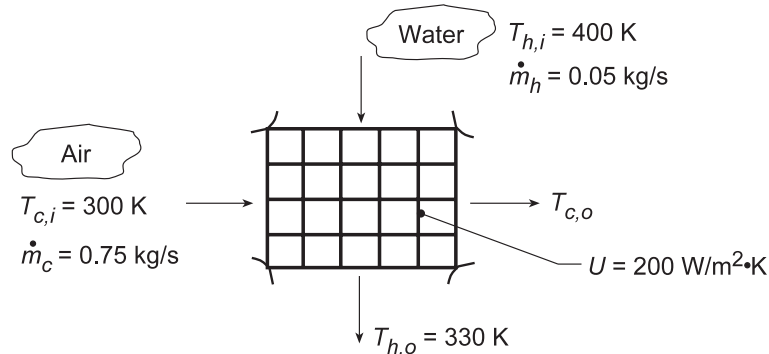

**ASSUMPTIONS:** (1) Negligible heat loss to surrounding, (2) Constant properties.

**PROPERTIES:** Table A.6, Water ( $\bar{T}_h = 365$  K):  $c_{p,h} = 4209$  J/kg·K; Table A.4, Air ( $\bar{T}_c \approx 310$  K):  $c_{p,c} = 1007$  J/kg·K.

**ANALYSIS:** (a) The required heat transfer rate is

$$q = \dot{m}_h c_{p,h} (T_{h,i} - T_{h,o}) = 0.05 \text{ kg/s} (4209 \text{ J/kg} \cdot \text{K}) 70 \text{ K} = 14,732 \text{ W}.$$

and from an energy balance on the cold fluid,

$$T_{c,o} = T_{c,i} + q / \dot{m}_c c_{p,c} = 300 \text{ K} + 14,732 \text{ W} / (0.75 \text{ kg/s} \times 1007 \text{ J/kg} \cdot \text{K}) = 319.5 \text{ K}$$

We will use Eq. 11.14 with Eq. 11S.1. From Fig. 11S.3, with  $P = (T_{c,o} - T_{c,i}) / (T_{h,i} - T_{c,i}) = 0.20$  and  $R = (T_{h,i} - T_{h,o}) / (T_{c,o} - T_{c,i}) = 3.6$ , we find  $F \approx 0.95$ . Then,

$$\Delta T_{lm,CF} = \frac{(T_{h,i} - T_{c,o}) - (T_{h,o} - T_{c,i})}{\ln(T_{h,i} - T_{c,o}) / (T_{h,o} - T_{c,i})} = 51.2 \text{ K}$$

Thus

$$A = q / U F \Delta T_{lm,CF} = 14,732 \text{ W} / 200 \text{ W/m}^2 \cdot \text{K} \times 0.95 \times 51.2 \text{ K} = 1.5 \text{ m}^2 \quad <$$

(b) To solve this “performance” problem using the log mean temperature difference method is very cumbersome. It requires solving the following equations for the two unknown outlet temperatures (and  $q$ ), where  $F$  is also a function of the two outlet temperatures,

$$q = \dot{m}_c c_{p,c} (T_{c,o} - T_{c,i}) \quad (1)$$

$$q = \dot{m}_h c_{p,h} (T_{h,i} - T_{h,o}) \quad (2)$$

$$q = U A F \Delta T_{lm,CF} \quad \Delta T_{lm,CF} = \frac{(T_{h,i} - T_{c,o}) - (T_{h,o} - T_{c,i})}{\ln(T_{h,i} - T_{c,o}) / (T_{h,o} - T_{c,i})} \quad (3,4)$$

Continued...

## PROBLEM 11S.5 (Cont.)

One rational approach is to work backward. For a specified value of  $q$ , Eqs. (1) and (2) can be used to solve for the outlet temperatures. Then  $F$  and  $\Delta T_{lm,CF}$  can be determined, and  $U$  can be found from Eq. (3). In this way, we can generate the following plot.

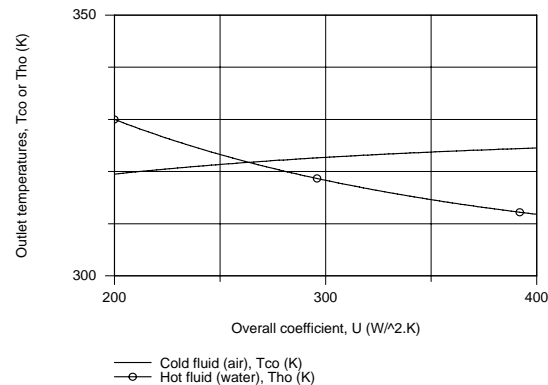

With a higher  $U$ , the outlet temperature of the hot fluid (water) decreases. A benefit is enhanced heat removal from the engine block and a cooler operating temperature. If it is desired to cool the engine with water at 330 K, the heat exchanger surface area and, hence its volume in the engine component could be reduced.

**COMMENT:** This problem is much easier to solve using the  $\epsilon$ -NTU method, as shown in this IHT model.

```

// Heat Exchanger Tool - Cross-flow with both fluids unmixed:
// For the cross-flow, single-pass heat exchanger with both fluids unmixed,
eps = 1 - exp((1 / Cr) * (NTU^0.22) * (exp(-Cr * NTU^0.78) - 1)) // Eq 11.32
// where the heat-capacity ratio is
Cr = Cmin / Cmax
// and the number of transfer units, NTU, is
NTU = U * A / Cmin // Eq 11.24
// The effectiveness is defined as
eps = q / qmax
qmax = Cmin * (Thi - Tci) // Eq 11.18, 11.19
// See Tables 11.3 and 11.4 and Fig 11.14
// Overall Energy Balances on Fluids:
q = mdoth * cph * (Thi - Tho)
q = mdotc * cpc * (Tco - Tci)
// Assigned Variables:
Cmin = Ch // Capacity rate, minimum fluid, W/K
Ch = mdoth * cph // Capacity rate, hot fluid, W/K
mdoth = 0.05 // Flow rate, hot fluid, kg/s
Thi = 400 // Inlet temperature, hot fluid, K
Tho = 330 // Outlet temperature, hot fluid, K; specified for part (a)
Cmax = Cc // Capacity rate, maximum fluid, W/K
Cc = mdotc * cpc // Capacity rate, cold fluid, W/K
mdotc = 0.75 // Flow rate, cold fluid, kg/s
Tci = 300 // Inlet temperature, cold fluid, K
U = 200 // Overall coefficient, W/m^2.K

// Properties Tool - Water (h)
// Water property functions :T dependence, From Table A.6
// Units: T(K), p(bars);
xh = 0 // Quality (0=sat liquid or 1=sat vapor)
rho_h = rho_Tx("Water",Tmh,xh) // Density, kg/m^3
cph = cp_Tx("Water",Tmh,xh) // Specific heat, J/kg.K
Tmh = Tfluid_avg(Thi,Tho)

// Properties Tool - Air(c)
// Air property functions : From Table A.4
// Units: T(K); 1 atm pressure
rho_c = rho_T("Air",Tmc) // Density, kg/m^3
cpc = cp_T("Air",Tmc) // Specific heat, J/kg.K
Tmc = Tfluid_avg(Tci,Tco)
    
```

## PROBLEM 11S.6

**KNOWN:** Single pass, cross-flow heat exchanger with hot exhaust gases (mixed) to heat water (unmixed)

**FIND:** Required surface area.

**SCHEMATIC:**



**ASSUMPTIONS:** (1) Negligible heat loss to surroundings, (2) Negligible kinetic and potential energy changes, (3) Exhaust gas properties assumed to be those of air.

**PROPERTIES:** Table A-6, Water ( $\bar{T}_c = (80 + 30)^\circ\text{C}/2 = 328\text{ K}$ ):  $c_p = 4184\text{ J/kg}\cdot\text{K}$ ; Table A-4, Air (1 atm,  $\bar{T}_h = (100 + 225)^\circ\text{C}/2 = 436\text{ K}$ ):  $c_p = 1019\text{ J/kg}\cdot\text{K}$ .

**ANALYSIS:** The rate equation for the heat exchanger follows from Eqs. 11.14 and 11S.1. The area is given as

$$A = q / U\Delta T_{\ell m} = q / UF\Delta T_{\ell m,CF} \quad (1)$$

where  $F$  is determined from Fig. 11S.4 using

$$P = \frac{80 - 30}{225 - 30} = 0.26 \quad \text{and} \quad R = \frac{225 - 100}{80 - 30} = 2.50 \quad \text{giving} \quad F \approx 0.92. \quad (2)$$

From an energy balance on the cold fluid, find

$$q = \dot{m}_c c_c (T_{c,o} - T_{c,i}) = 3 \frac{\text{kg}}{\text{s}} \times 4184 \frac{\text{J}}{\text{kg}\cdot\text{K}} (80 - 30)\text{K} = 627,600\text{ W}. \quad (3)$$

From Eq. 11.15, the LMTD for counter-flow conditions is

$$\Delta T_{\ell m,CF} = \frac{\Delta T_1 - \Delta T_2}{\ln(\Delta T_1 / \Delta T_2)} = \frac{(225 - 80) - (100 - 30)}{\ln(145/70)}^\circ\text{C} = 103.0^\circ\text{C}. \quad (4)$$

Substituting numerical values resulting from Eqs. (2-4) into Eq. (1), find the required surface area to be

$$A = 627,600\text{ W} / 200\text{ W/m}^2 \cdot \text{K} \times 0.92 \times 103.0\text{K} = 33.1\text{m}^2. \quad <$$

**COMMENTS:** Note that the properties of the exhaust gases were not needed in this method of analysis. If the  $\varepsilon$ -NTU method were used, find first  $C_h/C_c = 0.40$  with  $C_{\min} = C_h = 5021\text{ W/K}$ . From Eqs. 11.18 and 11.19, with  $C_h = C_{\min}$ ,  $\varepsilon = q/q_{\max} = (T_{h,i} - T_{h,o}) / (T_{h,i} - T_{c,i}) = (225 - 100) / (225 - 30) = 0.64$ . Using Fig. 11.15 with  $C_{\min}/C_{\max} = 0.4$  and  $\varepsilon = 0.64$ , find  $\text{NTU} = UA/C_{\min} \approx 1.4$ . Hence,

$$A = \text{NTU} \cdot C_{\min} / U \approx 1.4 \times 5021\text{ W/K} / 200\text{ W/m}^2 \cdot \text{K} = 35.2\text{m}^2.$$

Note agreement with above result.

## PROBLEM 11S.7

**KNOWN:** Conditions of oil and water for heat exchanger, one shell with 4 tube passes.

**FIND:** Length of exchanger tubes per pass,  $L$ ; and (b) Compute and plot the effectiveness,  $\epsilon$ , fluid outlet temperatures,  $T_{h,o}$  and  $T_{c,o}$ , and water-side convection coefficient,  $h_c$ , as a function of the water flow rate for  $5000 \leq \dot{m}_c \leq 15,000$  kg/h for the tube length found in part (a) with all other conditions remaining the same.

**SCHEMATIC:**

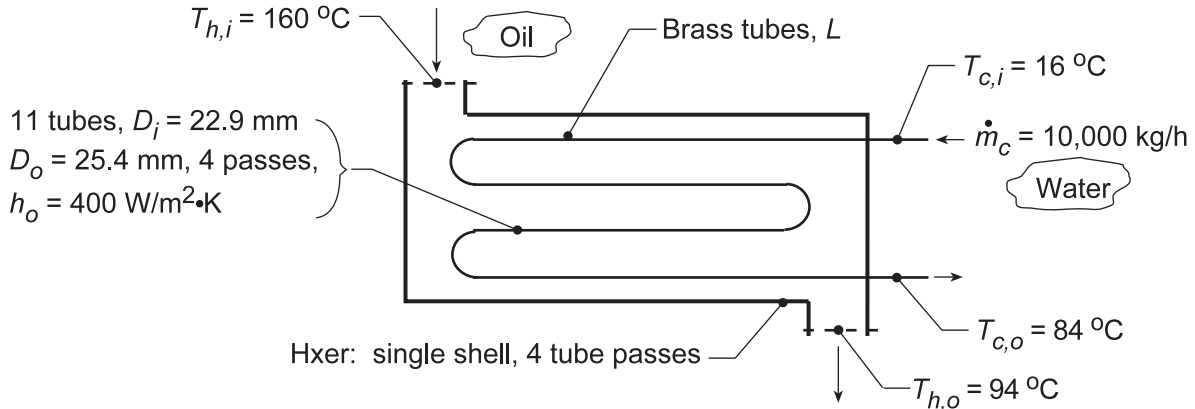

**ASSUMPTIONS:** (1) Negligible heat loss to surroundings, (2) Constant properties, (3) Fully-developed flow in tubes.

**PROPERTIES:** Table A-1, Brass (400 K):  $k = 137$  W/m·K; Table A-5, Water (323 K):  $\rho = 998.1$  kg/m<sup>3</sup>,  $k = 0.643$  W/m·K,  $c_p = 4182$  J/kg·K,  $\mu = 548 \times 10^{-6}$  N·s/m<sup>2</sup>,  $Pr = 3.56$ .

**ANALYSIS:** (a) From an energy balance on the water, the heat rate required is

$$q = \dot{m}_c c_c (T_{c,o} - T_{c,i}) = 10,000 / 3600 \text{ kg/s} \times 4182 \text{ J/kg} \cdot \text{K} (84 - 16)^\circ \text{C} = 789,933 \text{ W}. \quad (1)$$

The required tube length may be obtained from Eqs. 11.14 and 11.15,

$$q = U_o A_o F \Delta T_{\ell m, CF} \quad (2)$$

$$\Delta T_{\ell m, CF} = \left[ (160 - 84)^\circ \text{C} - (94 - 16)^\circ \text{C} \right] / \ln \left( (160 - 84) / (94 - 16) \right) = 77.0^\circ \text{C}.$$

From Fig. 11S.1,  $F = 0.86$  using  $P = (84 - 16) / (160 - 16) = 0.47$  and  $R = (160 - 94) / (84 - 16) = 0.97$ . From Eq. 11.5,

$$U_o = \left[ \frac{1}{h_o} + \frac{r_o}{k} \ln \frac{r_o}{r_i} + \frac{r_o}{r_i} \frac{1}{h_i} \right]^{-1}$$

where  $h_i$  must be estimated from the appropriate correlation. With  $N = 11$ , the number of tubes,

$$Re_D = \frac{4\dot{m}/N}{\pi D \mu} = \frac{4 \times (10,000/3600) \text{ kg/s} / (11)}{\pi \times 22.9 \times 10^{-3} \text{ m} \times 548 \times 10^{-6} \text{ N} \cdot \text{s/m}^2} = 25,621.$$

For fully developed turbulent flow, the Dittus-Boelter correlation with  $n = 0.4$  yields

$$Nu_D = h_i D / k = 0.023 Re_D^{0.8} Pr^{0.4} = 0.023 (25,621)^{0.8} (3.56)^{0.4} = 128.6$$

$$h_i = Nu_D (k/D) = 128.6 \times 0.643 \text{ W/m} \cdot \text{K} / (22.9 \times 10^{-3} \text{ m}) = 3610 \text{ W/m}^2 \cdot \text{K}.$$

Continued...

**PROBLEM 11S.7 (Cont.)**

$$U_o = \left[ \frac{1}{400 \text{ W/m}^2 \cdot \text{K}} + \frac{25.4 \times 10^{-3} \text{ m}}{2 \times 137 \text{ W/m} \cdot \text{K}} \ln \frac{25.4}{22.9} + \frac{25.4}{22.9} \times \frac{1}{3610 \text{ W/m}^2 \cdot \text{K}} \right]^{-1} = 355 \text{ W/m}^2 \cdot \text{K} .$$

Returning now to Eq. (2), find  $A_o$ , then the length,

$$A_o = \pi D_o L \times \text{No. of Passes} \times \text{No. of Tubes} = \pi \times 25.4 \times 10^{-3} \text{ m} \times 4 \times 11 L = 3.511 L$$

$$L = 789,933 \text{ W} / 3.511 \text{ m} \times 355 \text{ W/m}^2 \cdot \text{K} \times 0.86 \times 77.0^\circ \text{ C} = 9.6 \text{ m}$$

<

(b) Using the *IHT Heat Exchanger Tool, Shell and Tube, One-shell pass and N tube passes*, the *Correlation Tool, Forced Convection, Internal Flow for Turbulent, fully developed condition*, and the *Properties Tool for Water*, a model was developed using the effectiveness - NTU method to compute and plot  $T_{c,o}$ ,  $T_{h,o}$ ,  $\epsilon$ , and  $h_i$  as a function of  $\dot{m}_c$ .

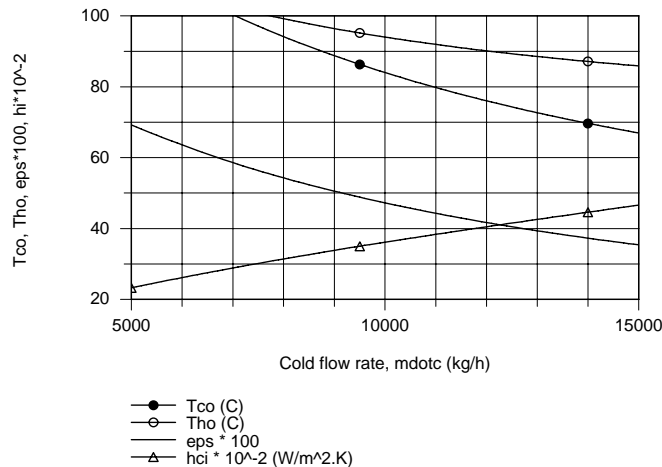

In order to avoid a boiling condition in the cold fluid, the cold flow rate should not be less than 8000 kg/h. As expected,  $T_{c,o}$  and  $T_{h,o}$  decrease and the internal convection coefficient increases nearly linearly with increasing flow rate. The effectiveness increases with increasing flow rate since the overall convection coefficient is increasing.

**COMMENTS:** (1) The thermal resistance of the brass tubes is negligible. Since  $L/D_i = 400$ , fully-developed conditions are reasonable.

(2) In the analysis of part (b), you have to specify the capacity rate for the hot fluid in order to solve the model. From the analysis of part (a) using the model, we found  $L = 9.56 \text{ m}$  and  $C_h = 11,974 \text{ W/K}$ .

## PROBLEM 11S.8

**KNOWN:** Power output and efficiency of an ocean energy conversion system. Temperatures and overall heat transfer coefficient of shell-and-tube evaporator.

**FIND:** (a) Evaporator area, (b) Water flow rate.

**SCHEMATIC:**

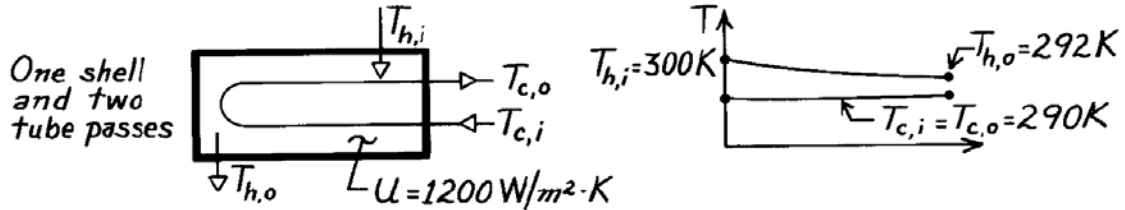

**ASSUMPTIONS:** (1) Negligible heat loss to surroundings, (2) Constant properties.

**PROPERTIES:** Table A-6, Water ( $\bar{T}_m = 296 \text{ K}$ ):  $c_p = 4181 \text{ J/kg} \cdot \text{K}$ .

**ANALYSIS:** (a) The efficiency is

$$\eta = \frac{\dot{W}}{q} = \frac{2 \text{ MW}}{q} = 0.03.$$

Hence the required heat transfer rate is

$$q = \frac{2 \text{ MW}}{0.03} = 66.7 \text{ MW}.$$

Also

$$\Delta T_{\ell m, CF} = \frac{(300 - 290) - (292 - 290)^\circ \text{C}}{\ln \frac{300 - 290}{292 - 290}} = 5^\circ \text{C}$$

and, with  $P = 0$  and  $R = \infty$ , from Fig. 11S.1 it follows that  $F = 1$ . Hence

$$A = \frac{q}{UF\Delta T_{\ell m, CF}} = \frac{6.67 \times 10^7 \text{ W}}{1200 \text{ W/m}^2 \cdot \text{K} \times 1 \times 5^\circ \text{C}}$$

$$A = 11,100 \text{ m}^2. \quad <$$

(b) The water flow rate through the evaporator is

$$\dot{m}_h = \frac{q}{c_{p,h}(T_{h,i} - T_{h,o})} = \frac{6.67 \times 10^7 \text{ W}}{4181 \text{ J/kg} \cdot \text{K} (300 - 292)}$$

$$\dot{m}_h = 1994 \text{ kg/s}. \quad <$$

**COMMENTS:** (1) From the  $\epsilon$ -NTU method,  $(C_{\min}/C_{\max}) = 0$ ,  $q_{\max} = 8.34 \times 10^7 \text{ W}$ ,  $\epsilon = 0.80$  and from Fig. 11.12,  $\text{NTU} \approx 1.65$ , giving  $A = 11,500 \text{ m}^2$ . (2) The required heat exchanger size is enormous due to the small temperature differences involved.

## PROBLEM 11S.9

**KNOWN:** Shell-and-tube heat exchanger with one shell pass and 20 tube passes.

**FIND:** Average convection coefficient for the outer tube surface.

**SCHEMATIC:**

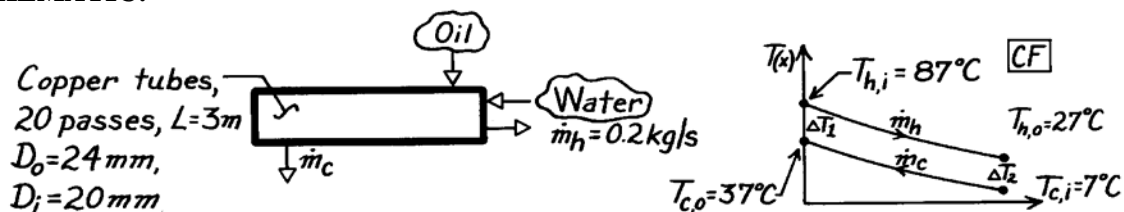

**ASSUMPTIONS:** (1) Negligible heat loss to surroundings, (2) Constant properties, (3) Type of oil not specified, (4) Thermal resistance of tubes negligible; no fouling.

**PROPERTIES:** Table A-6, Water, liquid ( $\bar{T}_h = 330$  K):  $c_p = 4184$  J/kg·K,  $k = 0.650$  W/m·K,  $\mu = 489 \times 10^{-6}$  N·s/m<sup>2</sup>,  $Pr = 3.15$ .

**ANALYSIS:** To find the average coefficient for the outer tube surface,  $h_o$ , we need to evaluate  $h_i$  for the internal tube flow and  $U$ , the overall coefficient. From Eq. 11.5,

$$\frac{1}{UA} = \frac{1}{h_i A_i} + \frac{1}{h_o A_o} = \frac{1}{N_t \pi L} \left[ \frac{1}{h_i D_i} + \frac{1}{h_o D_o} \right]$$

where  $N_t$  is the total number of tubes. Solving for  $h_o$ ,

$$h_o = D_o^{-1} \left[ (UA)^{-1} N_t \pi L - 1/h_i D_i \right]^{-1}. \quad (1)$$

Evaluate  $h_i$  from an appropriate correlation; begin by calculating the Reynolds number.

$$Re_{D,i} = \frac{4 \dot{m}_h}{\pi D_i \mu} = \frac{4 \times 0.2 \text{ kg/s}}{\pi (0.020 \text{ m}) 489 \times 10^{-6} \text{ N} \cdot \text{s/m}^2} = 26,038.$$

Hence, flow is turbulent and since  $L \gg D_i$ , the flow is likely to be fully developed. Use the Dittus-Boelter correlation with  $n = 0.3$  since  $T_s < T_m$ ,  $Nu_D = 0.023 Re_D^{4/5} Pr^{0.3}$

$$h_i = \frac{k}{D} Nu_D = \frac{0.650 \text{ W/m} \cdot \text{K}}{0.020 \text{ m}} \times 0.023 (26,038)^{4/5} (3.15)^{0.3} = 3594 \text{ W/m}^2 \cdot \text{K}. \quad (2)$$

To evaluate  $UA$ , we need to employ the rate equation, written as

$$UA = q / F \Delta T_{\ell m, CF} \quad (3)$$

where  $q = \dot{m}_h c_{p,h} (T_{h,i} - T_{h,o}) = 0.2 \text{ kg/s} \times 4184 \text{ J/kg} \cdot \text{K} (87 - 27)^\circ\text{C} = 50,208 \text{ W}$  and  $\Delta T_{\ell m, CF} = [\Delta T_1 - \Delta T_2] / \ln (\Delta T_1 / \Delta T_2) = [(87 - 37) - (27 - 7)]^\circ\text{C} / \ln [(87 - 37) / (27 - 7)] = 32.7^\circ\text{C}$ . Find  $F \approx 0.5$  using Fig. 11S.1 with  $P = (27 - 87) / (7 - 87) = 0.75$  and  $R = (7 - 37) / (27 - 87) = 0.50$ . Substituting numerical values in Eqs. (3) and (1), find

$$UA = 50,208 \text{ W} / 0.5 \times 32.7^\circ\text{C} = 3071 \text{ W/K} \quad (4)$$

$$h_o = (0.024 \text{ m})^{-1} \left[ (3071 \text{ W/K})^{-1} \times 20 \times \pi \times 3 \text{ m} - 1 / 3594 \text{ W/m}^2 \cdot \text{K} \times 0.020 \text{ m} \right]^{-1} = 878 \text{ W/m}^2 \cdot \text{K}. <$$

**COMMENTS:** Using the  $\epsilon$ -NTU method: find  $C_h$  and  $C_c$  to obtain  $C_r = 0.5$  and  $\epsilon = 0.75$ . From Eq. 11.30b,c find  $NTU = 3.44$  and  $UA = 2881 \text{ W/K}$ .



### PROBLEM 11S.10

**KNOWN:** Flow rates and inlet temperatures of exhaust gases and combustion air used in a cross-flow (one fluid mixed) heat exchanger. Overall heat transfer coefficient. Desired air outlet temperature.

**FIND:** Required heat exchanger surface area.

**SCHEMATIC:**

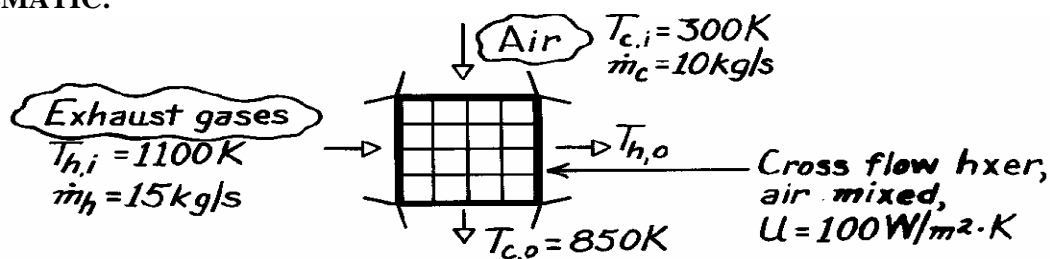

**ASSUMPTIONS:** (1) Steady-state conditions, (2) Negligible heat loss to surroundings, (3) Constant properties, (4) Gas properties are those of air.

**PROPERTIES:** Table A-4, Air ( $\bar{T}_m \approx 700$  K, 1 atm):  $c_p = 1075$  J/kg·K.

**ANALYSIS:** From Eqs. 11.6 and 11.7,

$$T_{h,o} = T_{h,i} - \frac{\dot{m}_c c_{p,c}}{\dot{m}_h c_{p,h}} (T_{c,o} - T_{c,i}) = 1100\text{K} - \frac{10 \text{ kg/s}}{15 \text{ kg/s}} (850 - 300)\text{K} = 733\text{K}.$$

From Eqs. 11.15, 11.17 and 11S.1,

$$\Delta T_{lm} = F \frac{(T_{h,i} - T_{c,o}) - (T_{h,o} - T_{c,i})}{\ln \left[ \frac{(T_{h,i} - T_{c,o})}{(T_{h,o} - T_{c,i})} \right]} = F \frac{250 - 433}{\ln(250/433)} = F \times 333\text{K}.$$

From Fig. 11S.4, with  $R = (300 - 850)/(733 - 1100) = 1.50$  and  $P = (733 - 1100)/(300 - 1100) = 0.46$ ,  $F \approx 0.73$ . With

$$q = \dot{m}_h c_{p,h} (T_{h,i} - T_{h,o}) = 15 \text{ kg/s} \times 1075 \text{ J/kg} \cdot \text{K} (367\text{K}) = 5.92 \times 10^6 \text{ W}$$

it follows from Eq. 11.14 that

$$A = \frac{5.92 \times 10^6 \text{ W}}{100 \text{ W/m}^2 \cdot \text{K} \times 0.73(333\text{K})} = 243 \text{ m}^2. \quad <$$

**COMMENTS:** Using the effectiveness-NTU method, from Eq. 11.21

$$\varepsilon = \frac{T_{c,o} - T_{c,i}}{T_{h,i} - T_{c,i}} = \frac{(850 - 300)\text{K}}{(1100 - 300)\text{K}} = 0.688.$$

Hence, with  $C_{\text{mixed}}/C_{\text{unmixed}} = C_c/C_h = 0.67$ , Fig. 11.15 gives  $\text{NTU} \approx 2.3$ . From Eq. 11.24,

$$A = \text{NTU} \frac{C_{\min}}{U} \approx 2.3 \frac{10 \text{ kg/s} \times 1075 \text{ J/kg} \cdot \text{K}}{100 \text{ W/m}^2 \cdot \text{K}} \approx 247 \text{ m}^2.$$

### PROBLEM 11S.11

**KNOWN:** Flow rate, specific heat and inlet temperature of gas in cross-flow heat exchanger. Flow rate and temperature of water which enters as saturated liquid and leaves as saturated vapor. Number of tubes, tube diameter and overall heat transfer coefficient.

**FIND:** Required tube length.

**SCHEMATIC:**

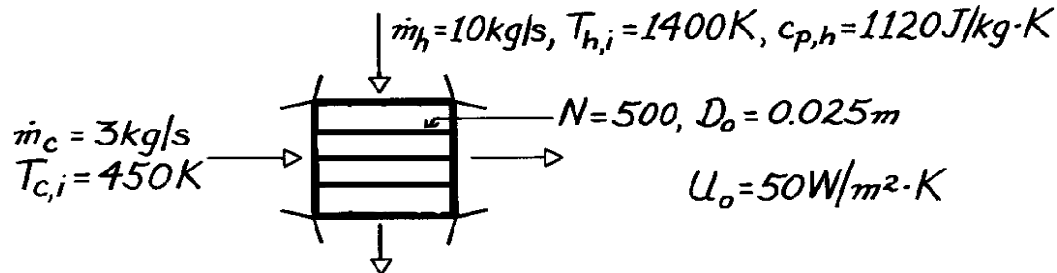

**ASSUMPTIONS:** (1) Negligible heat loss to surroundings, (2) Constant gas specific heat.

**PROPERTIES:** Table A-6, Saturated Water, ( $T = 450 \text{ K}$ ):  $h_{fg} = 2.024 \times 10^6 \text{ J/kg}$ .

**ANALYSIS:** The heat transfer rate can be found from considering the cold fluid,

$$q = \dot{m}_c h_{fg} = 3 \text{ kg/s} \times 2.024 \times 10^6 \text{ J/kg} = 6.072 \times 10^6 \text{ W}$$

Then an energy balance on the hot fluid yields

$$T_{h,o} = T_{h,i} - q/\dot{m}_h c_{p,h} = 1400 \text{ K} - 6.072 \times 10^6 \text{ W}/10 \text{ kg/s} \times 1120 \text{ J/kg} \cdot \text{K} = 857.9 \text{ K}$$

From Eqs. 11.15 and 11.17,

$$\Delta T_{lm,CF} = \frac{(T_{h,i} - T_{c,o}) - (T_{h,o} - T_{c,i})}{\ln \left[ \frac{(T_{h,i} - T_{c,o})}{(T_{h,o} - T_{c,i})} \right]} = \frac{(1400 - 450) \text{ K} - (857.9 - 450) \text{ K}}{\ln \left[ \frac{(1400 - 450) \text{ K}}{(857.9 - 450) \text{ K}} \right]} = 641 \text{ K}$$

From Fig. 11S.4, with  $P = (T_{c,o} - T_{c,i})/(T_{h,i} - T_{c,i}) = 0$ , find  $F = 1$ , thus

$$A_o = q/U\Delta T_{lm,CF} = 6.072 \times 10^6 \text{ W}/50 \text{ W/m}^2 \cdot \text{K} \times 641 \text{ K} = 189 \text{ m}^2$$

$$L = A_o/N\pi D_o = 189 \text{ m}^2/500 \times \pi \times 0.025 \text{ m} = 4.8 \text{ m}$$

<

## PROBLEM 11S.12

**KNOWN:** Compact heat exchanger (see Example 11S.2) after extended use has prescribed fouling factors on water and gas sides.

**FIND:** Gas-side overall heat transfer coefficient.

**SCHEMATIC:**

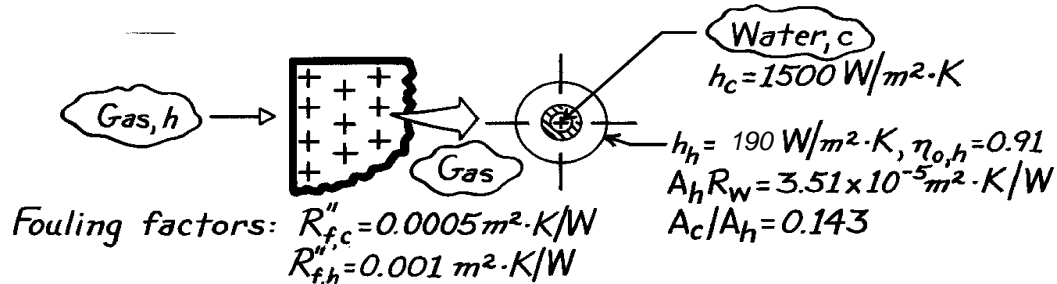

**ASSUMPTIONS:** (1) Heat transfer coefficients on the inside and outside (cold- and hot-sides) are the same as for the unfouled condition, (2) Temperature effectiveness of the finned hot side surface is the same as for the unfouled condition.

**ANALYSIS:** The overall heat transfer coefficient follows from Eq. 11.1 as

$$\frac{1}{U_h A_h} = \frac{1}{(\eta_o h A)_c} + \frac{R''_{f,c}}{(\eta_o A)_c} + R_w + \frac{R''_{f,h}}{(\eta_o A)_h} + \frac{1}{(\eta_o h A)_h}$$

where  $R_w$  and  $R''_f$  are the wall resistance and fouling factors, respectively. Multiply both sides by  $A_h$  and recognizing that  $\eta_{o,c} = 1$ , obtain

$$\frac{1}{U_h} = \frac{1}{h_c (A_c/A_h)} + \frac{R''_{f,c}}{(A_c/A_h)} + A_h R_w + \frac{R''_{f,h}}{\eta_{o,h}} + \frac{1}{\eta_o h_h}$$

Substitute numerical values from Example 11S.2 results ( $h_h$ ,  $\eta_{o,h}$ ,  $A_h R_w$ ,  $A_c/A_h$ ) and those from the problem statement ( $R''_{f,h}$ ,  $R''_{f,c}$ ,  $h_c$ ) to find,

$$\frac{1}{U_h} = \frac{1}{1500 \text{ W}/\text{m}^2 \cdot \text{K} (0.143)} + \frac{0.0005 \text{ m}^2 \cdot \text{K}/\text{W}}{(0.143)} + 3.51 \times 10^{-5} \text{ m}^2 \cdot \text{K}/\text{W} + \frac{0.001 \text{ m}^2 \cdot \text{K}/\text{W}}{0.91} + \frac{1}{0.91 \times 190 \text{ W}/\text{m}^2 \cdot \text{K}}$$

$$\frac{1}{U_h} = \left( 4.662 \times 10^{-3} + 3.497 \times 10^{-3} + 3.51 \times 10^{-5} + 1.099 \times 10^{-3} + 6.005 \times 10^{-3} \right) \text{ m}^2 \cdot \text{K}/\text{W}$$

$$U_h = 66.3 \text{ W}/\text{m}^2 \cdot \text{K}.$$

<

**COMMENTS:** For the unfouled condition, we found  $U_h = 100 \text{ W}/\text{m}^2 \cdot \text{K}$  from Example 11S.2. Note that the thermal resistance of the tube-fin material is negligible and that fouling has a significant effect, reducing  $U_h$  by 34%.

### PROBLEM 11S.13

**KNOWN:** Compact heat exchanger with prescribed core geometry and operating parameters.

**FIND:** Required heat exchanger volume; number of tubes in the longitudinal and transverse directions,  $N_L$  and  $N_T$ ; required tube length.

**SCHEMATIC:**

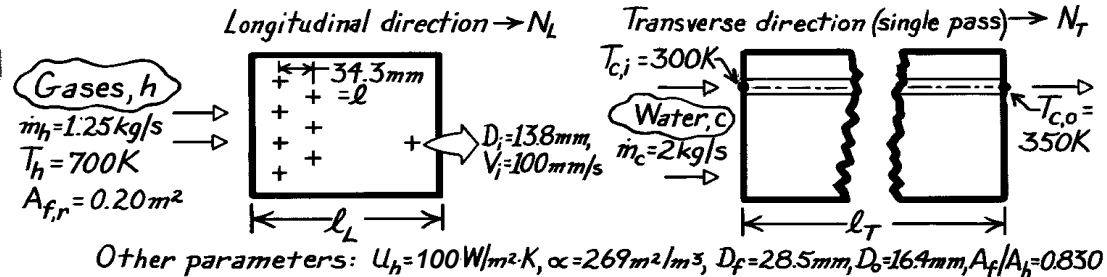

**ASSUMPTIONS:** (1) Negligible heat loss to surroundings, (2) Single pass operation, (3) Gas properties are those of air.

**PROPERTIES:** Table A-6, Water ( $\bar{T}_c = 325 \text{ K}$ ):  $\rho = 987.2 \text{ kg/m}^3$ ,  $c_p = 4182 \text{ J/kg} \cdot \text{K}$ ; Table A-4, Air (Assume  $T_{h,o} \approx 400 \text{ K}$ ,  $\bar{T}_h \approx 550 \text{ K}$ , 1 atm):  $c_p = 1040 \text{ J/kg} \cdot \text{K}$ .

**ANALYSIS:** To find the Hxer volume, first find  $A_h$  using the  $\epsilon$ -NTU method. By definition,

$$V = A_h / \alpha \quad \text{and} \quad A_h = \text{NTU} \cdot C_{\min} / U_h. \quad (1,2)$$

Find the capacity rates,  $q$ ,  $q_{\max}$  and  $\epsilon$ :

$$C_c = \dot{m}_c c_{p,c} = 2 \text{ kg/s} \times 4182 \text{ J/kg} \cdot \text{K} = 8364 \text{ W/K}$$

$$C_h = \dot{m}_h c_{p,h} = 1.25 \text{ kg/s} \times 1040 \text{ J/kg} \cdot \text{K} = 1300 \text{ W/K} \leftarrow C_{\min}$$

Hence,

$$C_r = \frac{C_{\min}}{C_{\max}} = 0.155.$$

It follows that

$$\epsilon = \frac{q}{q_{\max}} = \frac{C_c (T_{c,o} - T_{c,i})}{C_{\min} (T_{h,i} - T_{c,i})} = \frac{8364 \text{ W/K} (350 - 300) \text{ K}}{1300 \text{ W/K} (700 - 300) \text{ K}} = 0.804.$$

With  $\epsilon = 0.804$  and  $C_r = 0.155$ , find  $\text{NTU} \approx 1.7$  from Fig. 11.14 for a single-pass, cross flow Hxer with both fluids unmixed. Using Eqs. (2) and (1), find

$$A_h = 1.7 \times 1300 \text{ W/K} / 100 \text{ W/m}^2 \cdot \text{K} = 22.1 \text{ m}^2$$

$$V = 22.1 \text{ m}^2 / 269 \text{ m}^2/\text{m}^3 = 0.082 \text{ m}^3.$$

Continued .....

**PROBLEM 11S.13 (Cont.)**

To determine the number of tubes in the longitudinal direction, consider the tubular arrangement in the sketch. The Hxer volume can be written as

$$V = A_{fr} \times \ell_L \quad (3)$$

where

$$\ell_L = (N_L - 1)\ell + D_f \quad (4)$$

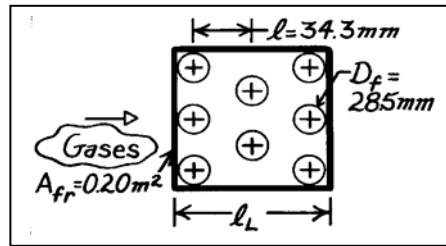

and  $N_L$  is the number of tubes in the longitudinal direction. Combining Eqs. (3) and (4) and substituting numerical values, find

$$N_L = (V / A_{fr} - D_f) / \ell + 1 \quad (5)$$

where  $D_f$  is the overall diameter of the finned tube, and

$$N_L = (0.082 \text{ m}^3 / 0.20 \text{ m}^2 - 0.0285 \text{ m}) / 0.0343 + 1 = 12.1 \approx 13. \quad <$$

To determine the number of tubes in the transverse direction, compare the overall water flow rate  $\dot{m}_c$  with that for a single tube,  $\dot{m}_t$ . That is,

$$\dot{m}_t = \rho_c A_t V_i \quad (6)$$

where  $A_t$  is the tube inner cross-sectional area  $(\pi D_i^2 / 4)$  and  $V_i$  the internal velocity. Hence,

$$N = \dot{m}_c / \dot{m}_t = (2 \text{ kg/s}) / 987.2 \text{ kg/m}^3 \times \frac{\pi}{4} (0.0138 \text{ m})^2 \times 0.100 \text{ m/s} = 135.4 \approx 135.$$

The total number of tubes required,  $N$ , is 135; the number in the transverse direction is

$$N_T = N / N_L = 135 / 13 = 10.4 \approx 11. \quad <$$

To determine the water tube length, recognize that the total area ( $A_h$ ), less that of the finned surfaces ( $A_f$ ), will be that of the water tube surface area. That is,

$$A_h - A_f = \pi D_o \ell_T \cdot N.$$

From specification of the core geometry, we know  $A_f / A_h = 0.830$ ; solve for  $\ell_T$  to obtain

$$\ell_T = A_h (1 - A_f / A_h) / \pi D_o \cdot N \quad (7)$$

$$\ell_T = 22.1 \text{ m}^2 (1 - 0.830) / \pi (0.0164 \text{ m}) \times 135 = 0.54 \text{ m}. \quad <$$

**COMMENTS:** In summary we find that

Total number of tubes, $N$ ( $N_T \times N_L$ )	143
Tubes in longitudinal direction, $N_L$	13
Tubes in transverse direction, $N_T$	11

with a total surface area of  $22.1 \text{ m}^2$ . The length of the exchanger is

Length in longitudinal direction, $\ell_L$	0.41 m
Length in transverse direction, $\ell_T$	0.54 m.

### PROBLEM 11S.14

**KNOWN:** Compact heat exchanger geometry, gas-side flow rate and inlet temperature, water-side convection coefficient, water flow rate, and water inlet and outlet temperatures.

**FIND:** Gas-side overall heat transfer coefficient. Required heat exchanger volume.

**SCHEMATIC:**

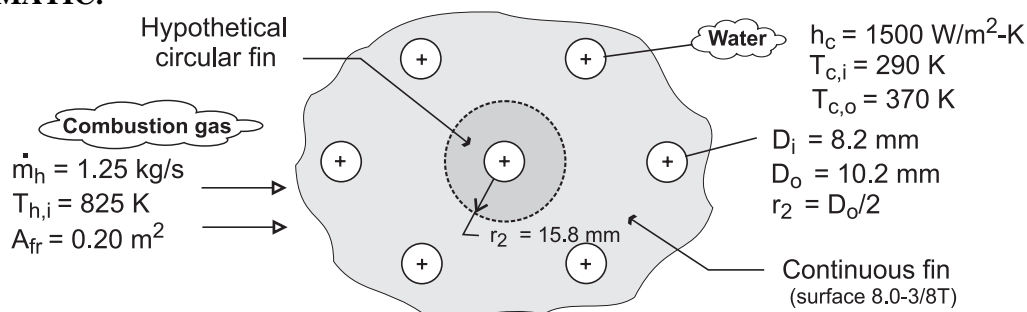

**ASSUMPTIONS:** (1) Gas has properties of atmospheric air at an assumed mean temperature of 700 K, (2) Negligible fouling, (3) Negligible heat exchange with the surroundings.

**PROPERTIES:** Table A-1, aluminum ( $T \approx 300$  K):  $k = 237$  W/m·K. Table A-4, air ( $p = 1$  atm,  $\bar{T} = 700$  K):  $c_p = 1075$  J/kg·K,  $\mu = 338.8 \times 10^{-7}$  N·s/m<sup>2</sup>,  $Pr = 0.695$ . Table A-6, water ( $\bar{T} = 330$  K):  $c_p = 4184$  J/kg·K.

**ANALYSIS:** For the prescribed heat exchanger core,

$$\frac{1}{U_h} = \frac{1}{h_c (A_c / A_h)} + A_h R_w + \frac{1}{\eta_{o,h} h_h}$$

where

$$\frac{A_c}{A_h} \approx \frac{D_i}{D_o} \left( 1 - \frac{A_{f,h}}{A_h} \right) = \frac{8.2}{10.2} (1 - 0.913) = 0.070$$

The product of  $A_h$  and the wall conduction resistance is

$$A_h R_w = \frac{\ln(D_o / D_i)}{2\pi k L / A_h} = \frac{D_i \ln(D_o / D_i)}{2k(A_c / A_h)} = \frac{0.0082\text{m} \times \ln(10.2/8.2)}{2 \times 237 \text{ W/m} \cdot \text{K} (0.070)} = 5.39 \times 10^{-5} \text{ m}^2 \cdot \text{K/W}$$

With a gas-side mass velocity of  $G = \dot{m}_h / \sigma A_{fr} = 1.25 \text{ kg/s} / 0.534 \times 0.20 \text{ m}^2 = 11.7 \text{ kg/s} \cdot \text{m}^2$ ,

$$Re = \frac{G D_h}{\mu} = \frac{11.7 \text{ kg/s} \cdot \text{m}^2 \times 0.00363\text{m}}{338.8 \times 10^{-7} \text{ N} \cdot \text{s/m}^2} = 1254$$

and Fig. 11S.6 yields  $j_H \approx 0.0096$ . Hence,

$$h_h \approx \frac{0.0096 G c_p}{Pr^{2/3}} = \frac{0.0096 (11.7 \text{ kg/s} \cdot \text{m}^2) (1075 \text{ J/kg} \cdot \text{K})}{(0.695)^{2/3}} = 154 \text{ W/m}^2 \cdot \text{K}$$

Continued .....

**PROBLEM 11S.14 (Cont.)**

With  $r_{2c} = r_2 + t/2 = 15.8 \text{ mm} + 0.330 \text{ mm}/2 = 15.97 \text{ mm}$ ,  $r_{2c}/r_1 = 15.97/5.1 = 3.13$ ,  $L = r_2 - r_1 = 10.7 \text{ mm}$ ,  $L_c = L + t/2 = 10.87 \text{ mm} = 0.0109 \text{ m}$ ,  $A_p = L_c t = 3.59 \times 10^{-6} \text{ m}^2$ , and  $L_c^{3/2} (h_h/kA_p)^{1/2} = 0.484$ , Fig. 3.20 yields  $\eta_f \approx 0.77$ . Hence,

$$\eta_{o,h} = 1 - \frac{A_f}{A} (1 - \eta_f) = 1 - 0.913(1 - 0.77) = 0.790$$

$$U_h^{-1} = \left(1500 \text{ W/m}^2 \cdot \text{K} \times 0.07\right)^{-1} + 5.39 \times 10^{-5} \text{ m}^2 \cdot \text{K/W} + \left(0.79 \times 154 \text{ W/m}^2 \cdot \text{K}\right)^{-1} = 0.0183 \text{ m}^2 \cdot \text{K/W}$$

$$U_h = 56.2 \text{ W/m}^2 \cdot \text{K} \quad <$$

With  $q = C_c (T_{c,o} - T_{c,i}) = 4184 \text{ W/K} \times 80 \text{ K} = 3.35 \times 10^5 \text{ W}$ ,  $q_{\max} = C_{\min} (T_{h,i} - T_{c,i}) = 1344 \text{ W/K} \times 535 \text{ K} = 7.19 \times 10^5 \text{ W}$ ,  $\epsilon = 0.466$  and  $C_r = 0.321$ . From Figure 11.14, we then obtain  $\text{NTU} \approx 0.65$ . The required gas-side surface area is then

$$A_h = \frac{\text{NTU} \times C_{\min}}{U_h} = \frac{0.65 \times 1344 \text{ W/K}}{56.2 \text{ W/m}^2 \cdot \text{K}} = 15.5 \text{ m}^2$$

With  $\alpha = 587 \text{ m}^2/\text{m}^3$ , the required volume is

$$V = \frac{A_h}{\alpha} = \frac{15.5 \text{ m}^2}{587 \text{ m}^2/\text{m}^3} = 0.026 \text{ m}^3 \quad <$$

**COMMENTS:** (1) Although  $U_h$  is small and  $A_h$  larger for the continuous fins than for the circular fins of Example 11.6, the much larger value of  $\alpha$  renders the volume requirement smaller.

(2) The heat exchanger length is  $L = V/A_{fr} = 0.132 \text{ m}$ , and the number of tube rows is

$$N_L \approx \frac{L}{S_L} + 1 = 7$$

(3) The hypothetical fin radius ( $r_2 = 15.8 \text{ mm}$ ) was estimated to be the arithmetic mean of one-half the center-to-center spacing between one tube and its six neighbors.

### PROBLEM 11S.15

**KNOWN:** Cooling coil geometry. Air flow rate and inlet and outlet temperatures. Refrigerant-134a pressure and convection coefficient.

**FIND:** Required number of tube rows.

**SCHEMATIC:**

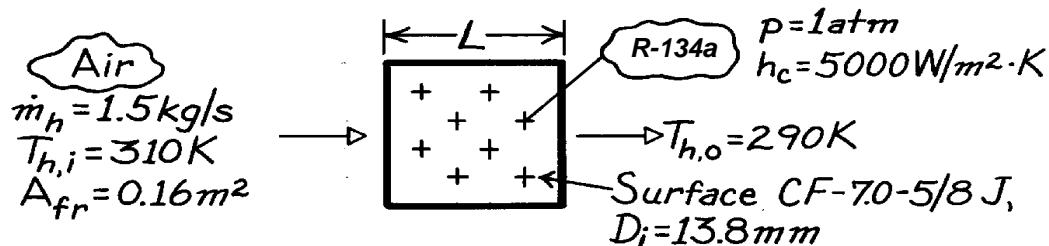

**ASSUMPTIONS:** (1) Negligible fouling, (2) Constant properties, (3) Negligible heat loss to surroundings.

**PROPERTIES:** Table A-4, Air ( $\bar{T}_h = 300$  K, 1 atm):  $c_p = 1007$  J/kg·K,  $\mu = 184.6 \times 10^{-7}$  N·s/m<sup>2</sup>,  $k = 0.0263$  W/m·K,  $Pr = 0.707$ ; Table A-5, Sat. R-134a (1 atm):  $T_{sat} = T_c = 247$  K,  $h_{fg} = 217$  kJ/kg.

**ANALYSIS:** The required number of tube rows is

$$N_L = (L - D_f) / S_L + 1$$

where

$$L = V / A_{fr} \quad V = A_h / \alpha \quad A_h = NTU (C_{min} / U_h)$$

$$1 / U_h = 1 / h_c (A_c / A_h) + A_h R_w + 1 / \eta_{o,h} h_h.$$

From Ex. 11S.2,  $(A_c / A_h) = 0.143$  and  $A_h R_w = 3.51 \times 10^{-5}$  m<sup>2</sup>·K/W. With

$$G = \frac{\dot{m}_h}{\sigma A_{fr}} = \frac{1.50 \text{ kg/s}}{0.449 \times 0.16 \text{ m}^2} = 20.9 \text{ kg/s} \cdot \text{m}^2$$

$$Re = \frac{GD_h}{\mu} = \frac{20.9 \text{ kg/s} \cdot \text{m}^2 \times 6.68 \times 10^{-3} \text{ m}}{184.6 \times 10^{-7} \text{ N} \cdot \text{s/m}^2} = 7563$$

and Fig. 11S.5 gives  $j_H \approx 0.0068$ . Hence,

$$h_h = j_h \frac{Gc_p}{Pr^{2/3}} = 0.0068 \frac{20.9 \text{ kg/s} \cdot \text{m}^2 \times 1007 \text{ J/kg} \cdot \text{K}}{(0.707)^{2/3}} = 180 \text{ W/m}^2 \cdot \text{K}.$$

With  $L_c = 6.18$  mm and  $A_p = 1.57 \times 10^{-6}$  m<sup>2</sup> from Ex. 11S.5,  $L_c^{3/2} (h_h / kA_p)^{1/2} = 0.338$  and, from Fig. 3.20,  $\eta_f \approx 0.89$  for  $r_{2c}/r_1 = 1.75$ . Hence, as in Ex. 11S.5,  $\eta_{o,h} = 0.91$  and

$$1 / U_h = 1 / (5000 \text{ W/m}^2 \cdot \text{K}) 0.143 + 3.51 \times 10^{-5} \text{ m}^2 \cdot \text{K/W} + 1 / (0.91 \times 180 \text{ W/m}^2 \cdot \text{K})$$

$$U_h = 133 \text{ W/m}^2 \cdot \text{K}.$$

Continued .....



### PROBLEM 11S.15 (Cont.)

With  $C_{\min}/C_{\max} = 0$  and  $C_{\min} = \dot{m}_h c_{p,h} = 1511 \text{ W/K}$ ,

$$\varepsilon = \frac{q}{q_{\max}} = \frac{C_h (T_{h,i} - T_{h,o})}{C_h (T_{h,i} - T_{c,i})} = \frac{20 \text{ K}}{67 \text{ K}} = 0.317$$

$$\text{NTU} = -\ln(1 - \varepsilon) = 0.382$$

and

$$A_h = \text{NTU} \frac{C_{\min}}{U_h} = 0.382 \frac{1511 \text{ W/K}}{133 \text{ W/m}^2 \cdot \text{K}} = 4.34 \text{ m}^2.$$

Hence,

$$L = \frac{A_h}{\alpha A_{\text{fr}}} = \frac{4.34 \text{ m}^2}{(269 \text{ m}^2/\text{m}^3) 0.16 \text{ m}^2} = 0.101 \text{ m}$$

and

$$N_L = \frac{L - D_f}{S_L} + 1 = \frac{0.0723}{0.0343 \text{ m}} + 1 = 3.1.$$

Hence, three or more rows must be used. <

**COMMENTS:** For the prescribed operating conditions, the heat rate would be

$$q = C_h (T_{h,i} - T_{h,o}) = 1511 \text{ W/K} (20 \text{ K}) = 30,220 \text{ W}.$$

If R-134a enters the tubes as saturated liquid, a flow rate of at least

$$\dot{m}_c = \frac{q}{h_{\text{fg}}} = \frac{30,220 \text{ W}}{217,000 \text{ J/kg}} = 0.139 \text{ kg/s}$$

would be needed to maintain saturated conditions in the tubes.

### PROBLEM 11S.16

**KNOWN:** Cooling coil geometry. Air flow rate and inlet temperature. R-134a pressure and convection coefficient.

**FIND:** Air outlet temperature.

**SCHEMATIC:**

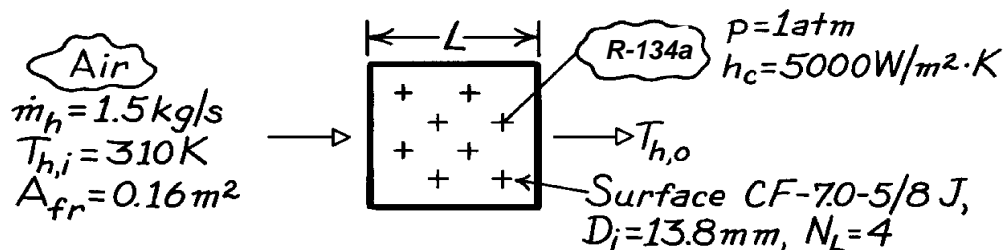

**ASSUMPTIONS:** (1) Negligible fouling, (2) Constant properties, (3) Negligible heat loss to surroundings.

**PROPERTIES:** Table A-4, Air ( $\bar{T}_h \approx 300 \text{ K}$ , 1 atm):  $c_p = 1007 \text{ J/kg} \cdot \text{K}$ ,  $\mu = 184.6 \times 10^{-7} \text{ N} \cdot \text{s/m}^2$ ,  $k = 0.0263 \text{ W/m} \cdot \text{K}$ ,  $Pr = 0.707$ ; Table A-5, Sat. R-134a (1 atm):  $T_{\text{sat}} = T_c = 247 \text{ K}$ ,  $h_{fg} = 217 \text{ kJ/kg}$ .

**ANALYSIS:** To obtain the air outlet temperature, we must first obtain the heat rate from the  $\epsilon$ -NTU method. To find  $A_h$ , first find the heat exchanger length,

$$L \approx (N_L - 1)S_L + D_f = 3(0.0343 \text{ m}) + 0.0285 \text{ m} = 0.131 \text{ m}.$$

Hence,

$$V = A_{fr}L = 0.16 \text{ m}^2 (0.131 \text{ m}) = 0.021 \text{ m}^3$$

$$A_h = \alpha V = (269 \text{ m}^2 / \text{m}^3) 0.021 \text{ m}^3 = 5.65 \text{ m}^2.$$

The overall coefficient is

$$\frac{1}{U_h} = \frac{1}{h_c (A_c / A_h)} + A_h R_w + \frac{1}{\eta_{o,h} h_h}$$

where Ex. 11S.2 yields  $(A_c / A_h) = 0.143$  and  $A_h R_w = 3.51 \times 10^{-5} \text{ m}^2 \cdot \text{K/W}$ . With

$$G = \frac{\dot{m}_h}{\sigma A_{fr}} = \frac{1.50 \text{ kg/s}}{0.449 \times 0.16 \text{ m}^2} = 20.9 \text{ kg/s} \cdot \text{m}^2$$

$$Re = \frac{GD_h}{\mu} = \frac{20.9 \text{ kg/s} \cdot \text{m}^2 \times 6.68 \times 10^{-3} \text{ m}}{184.6 \times 10^{-7} \text{ N} \cdot \text{s/m}^2} = 7563.$$

Fig. 11S.5 gives  $j_H \approx 0.0068$ . Hence,

$$h_h = j_h \frac{Gc_p}{Pr^{2/3}} = 0.0068 \frac{20.9 \text{ kg/s} \cdot \text{m}^2 \times 1007 \text{ J/kg} \cdot \text{K}}{(0.707)^{2/3}}$$

$$h_h = 180 \text{ W/m}^2 \cdot \text{K}.$$

Continued .....

### PROBLEM 11S.16 (Cont.)

With  $L_c = 6.18 \text{ mm}$  and  $A_p = 1.57 \times 10^{-6} \text{ m}^2$  from Ex. 11S.2,  $L_c^{3/2} (h_h / kA_p)^{1/2} = 0.338$  and, from Fig. 3.20,  $\eta_f \approx 0.89$  for  $r_{2c}/r_1 = 1.75$ . Hence, as in Ex. 11S.2,  $\eta_{o,h} = 0.91$  and

$$\frac{1}{U_h} = \frac{1}{(5000 \text{ W/m}^2 \cdot \text{K})0.143} + 3.51 \times 10^{-5} \text{ m}^2 \cdot \text{K/W} + \frac{1}{0.91(180 \text{ W/m}^2 \cdot \text{K})}$$

$$U_h = 133 \text{ W/m}^2 \cdot \text{K}.$$

With

$$C_{\min} = C_h = \dot{m}_h c_{p,h} = 1.5 \text{ kg/s}(1007 \text{ J/kg} \cdot \text{K}) = 1511 \text{ W/K}$$

$$NTU = \frac{U_h A_h}{C_{\min}} = \frac{133 \text{ W/m}^2 \cdot \text{K} \times 5.65 \text{ m}^2}{1511 \text{ W/K}} = 0.497.$$

With  $C_{\min}/C_{\max} = 0$ , Eq. 11.35a yields

$$\varepsilon = 1 - \exp(-NTU) = 1 - \exp(-0.497) = 0.392.$$

Hence,

$$q = \varepsilon q_{\max} = \varepsilon C_{\min} (T_{h,i} - T_{c,i}) = 0.392(1511 \text{ W/K})63 \text{ K}$$

$$q = 37,200 \text{ W}.$$

The air outlet temperature is

$$T_{h,o} = T_{h,i} - \frac{q}{C_h} = 310 \text{ K} - \frac{37,200 \text{ W}}{1511 \text{ W/K}} = 285 \text{ K}.$$

<

**COMMENTS:** If R-134a enters the tubes as saturated liquid, a flow rate of at least

$$\dot{m}_c = \frac{q}{h_{fg}} = \frac{37,200 \text{ W}}{217,000 \text{ J/kg}} = 0.171 \text{ kg/s}$$

would be needed to maintain saturated conditions in the tubes.

### PROBLEM 11S.17

**KNOWN:** Cooling coil geometry. Gas flow rate and inlet temperature. Water pressure, flow rate and convection coefficient.

**FIND:** Required number of tube rows.

**SCHEMATIC:**

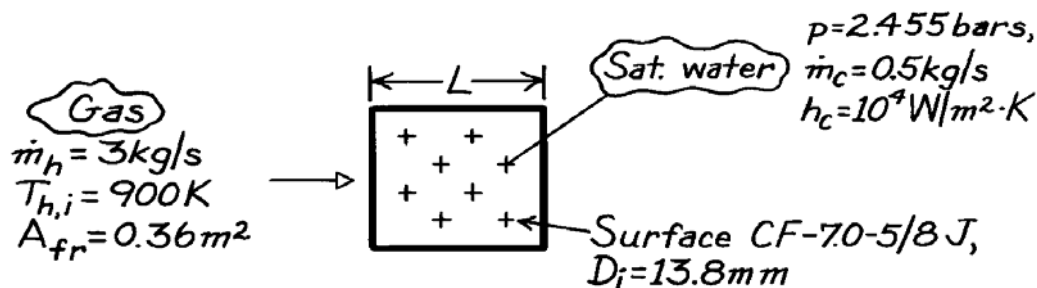

**ASSUMPTIONS:** (1) Negligible fouling, (2) Constant properties, (3) Negligible heat loss to surroundings.

**PROPERTIES:** Table A-4, Air ( $\bar{T}_h \approx 725$  K, 1 atm):  $c_p = 1081$  J/kg·K,  $\mu = 346.7 \times 10^{-7}$  N·s/m<sup>2</sup>,  $k = 0.0536$  W/m·K,  $Pr = 0.698$ ; Table A-6, Sat. water (2.455 bar):  $T_{\text{sat}} = T_c = 400$  K,  $h_{fg} = 2183$  kJ/kg.

**ANALYSIS:** The required number of tube rows is

$$N_L = \frac{L - D_f}{S_L} + 1$$

where

$$L = \frac{V}{A_{fr}} \quad V = \frac{A_h}{\alpha} \quad A_h = NTU \frac{C_{\min}}{U_h}$$

$$\frac{1}{U_h} = \frac{1}{h_c (A_c / A_h)} + A_h R_w + \frac{1}{\eta_{o,h} h_h}$$

From Ex. 11S.2,  $(A_c / A_h) \approx 0.143$  and

$$A_h R_w = \frac{D_i \ln(D_o / D_i)}{2k (A_c / A_h)} = \frac{(0.0138 \text{ m}) \ln(16.4 / 13.8)}{2(15 \text{ W/m} \cdot \text{K})(0.143)} = 5.55 \times 10^{-4} \text{ m}^2 \cdot \text{K/W}$$

With

$$G = \frac{\dot{m}_h}{\sigma A_{fr}} = \frac{3.0 \text{ kg/s}}{0.449 \times 0.36 \text{ m}^2} = 18.6 \text{ kg/s} \cdot \text{m}^2$$

$$Re = \frac{GD_h}{\mu} = \frac{18.6 \text{ kg/s} \cdot \text{m}^2 \times 6.68 \times 10^{-3} \text{ m}}{346.7 \times 10^{-7} \text{ N} \cdot \text{s/m}^2} = 3576$$

and Fig. 11.16S.5 gives  $j_h \approx 0.009$ . Hence,

$$h_h = j_h \frac{Gc_p}{Pr^{2/3}} = 0.009 \frac{18.6 \text{ kg/s} \cdot \text{m}^2 \times 1081 \text{ J/kg} \cdot \text{K}}{(0.698)^{2/3}} = 230 \text{ W/m}^2 \cdot \text{K}$$

Continued .....

**PROBLEM 11S.17 (Cont.)**

With  $r_{2c}/r_1 = 1.75$ ,  $L_c = 6.18$  mm and  $A_p = 1.57 \times 10^{-6} \text{ m}^2$  from Ex. 11.6,  $L_c^{3/2} (h_h/kA_p)^{1/2} = 1.52$  and Fig. 3.20 gives  $\eta_f \approx 0.40$ . Hence,

$$\eta_{o,h} = 1 - \frac{A_f}{A} (1 - \eta_f) = 1 - 0.83(1 - 0.4) = 0.50.$$

Hence,

$$\frac{1}{U_h} = \frac{1}{(10^4 \text{ W/m}^2 \cdot \text{K})0.143} + 5.55 \times 10^{-4} \text{ m}^2 \cdot \text{K/W} + \frac{1}{0.50(230 \text{ W/m}^2 \cdot \text{K})}$$

$$U_h = 100.5 \text{ W/m}^2 \cdot \text{K}.$$

With

$$q = \dot{m}_c h_{fg} = 0.5 \text{ kg/s} (2.183 \times 10^6 \text{ J/kg}) = 1.092 \times 10^6 \text{ W}$$

$$C_{\min} = C_h = 3.0 \text{ kg/s} (1081 \text{ J/kg} \cdot \text{K}) = 3243 \text{ W/K}$$

$$q_{\max} = C_{\min} (T_{h,i} - T_{c,i}) = 3243 \text{ W/K} (500 \text{ K}) = 1.622 \times 10^6 \text{ W}$$

find

$$\varepsilon = \frac{q}{q_{\max}} = \frac{1.092 \times 10^6 \text{ W}}{1.622 \times 10^6 \text{ W}} = 0.674.$$

From Eq. 11.35b

$$NTU = -\ln(1 - \varepsilon) = -\ln(1 - 0.674) = 1.121.$$

Hence,

$$A_h = NTU \frac{C_{\min}}{U_h} = 1.121 \frac{3243 \text{ W/K}}{100.5 \text{ W/m}^2 \cdot \text{K}} = 36.17 \text{ m}^2$$

$$L = \frac{A_h}{A_{fr} \alpha} = \frac{36.17 \text{ m}^2}{0.36 \text{ m}^2 (269 \text{ m}^2/\text{m}^3)} = 0.373 \text{ m}$$

$$N_L = \frac{L - D_f}{S_L} + 1 = \frac{373 - 28.5}{34.3} + 1 = 11.06 \approx 11. \quad <$$

**COMMENTS:** The gas outlet temperature is

$$T_{h,o} = T_{h,i} - \frac{q}{C_{\min}} = 900 \text{ K} - \frac{1.092 \times 10^6 \text{ W}}{3243 \text{ W/K}} = 564 \text{ K}.$$

Hence  $\bar{T}_h = (900 \text{ K} + 564 \text{ K})/2 = 732 \text{ K}$  is in good agreement with the assumed value.

## PROBLEM 11S.18

**KNOWN:** Cooling coil geometry. Gas flow rate and inlet temperature. Water pressure and convection coefficient.

**FIND:** Gas outlet temperature.

**SCHEMATIC:**

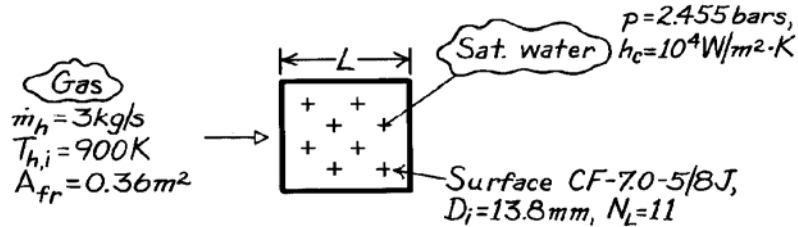

**ASSUMPTIONS:** (1) Negligible fouling, (2) Constant properties, (3) Negligible heat loss to surroundings.

**PROPERTIES:** Table A-4, Air ( $\bar{T}_h \approx 725$  K, 1 atm):  $c_p = 1081$  J/kg·K,  $\mu = 346.7 \times 10^{-7}$  N·s/m<sup>2</sup>,  $k = 0.0536$  W/m·K,  $Pr = 0.698$ ; Table A-6, Sat. water (2.455 bar):  $T_{\text{sat}} = T_c = 400$  K,  $h_{fg} = 2183$  kJ/kg.

**ANALYSIS:** To obtain  $T_{h,o}$ , first obtain  $q$  from the  $\epsilon$ -NTU method. To determine NTU,  $A_h$  must be found from knowledge of  $L$ .

$$L \approx (N_L - 1)S_L + D_f = 10(0.0343 \text{ m}) + 0.0285 \text{ m} = 0.372 \text{ m}.$$

Hence,

$$V = A_{fr}L = 0.36 \text{ m}^2 (0.372 \text{ m}) = 0.134 \text{ m}^3$$

$$A_h = \alpha V = (269 \text{ m}^2 / \text{m}^3) 0.134 \text{ m}^3 = 36.05 \text{ m}^2.$$

The overall coefficient is

$$\frac{1}{U_h} = \frac{1}{h_c (A_c / A_h)} + A_h R_w + \frac{1}{\eta_{o,h} h_h}.$$

From Ex. 11S.2,  $(A_c / A_h) \approx 0.143$  and

$$A_h R_w = \frac{D_i \ln(D_o / D_i)}{2k(A_c / A_h)} = \frac{(0.0138 \text{ m}) \ln(16.4 / 13.8)}{2(15 \text{ W/m} \cdot \text{K})(0.143)} = 5.55 \times 10^{-4} \text{ m}^2 \cdot \text{K} / \text{W}.$$

With

$$G = \frac{\dot{m}_h}{\sigma A_{fr}} = \frac{3.0 \text{ kg/s}}{0.449 \times 0.36 \text{ m}^2} = 18.6 \text{ kg/s} \cdot \text{m}^2$$

$$Re = \frac{GD_h}{\mu} = \frac{18.6 \text{ kg/s} \cdot \text{m}^2 \times 6.68 \times 10^{-3} \text{ m}}{346.7 \times 10^{-7} \text{ N} \cdot \text{s/m}^2} = 3576$$

and Fig. 11S.5 gives  $j_H \approx 0.009$ . Hence,

Continued .....

**PROBLEM 11S.18 (Cont.)**

$$h_h = j_h \frac{Gc_p}{Pr^{2/3}} = 0.009 \frac{18.6 \text{ kg/s} \cdot \text{m}^2 \times 1081 \text{ J/kg} \cdot \text{K}}{(0.698)^{2/3}}$$

$$h_h = 230 \text{ W/m}^2 \cdot \text{K}.$$

With  $r_{2c}/r_1 = 1.75$ ,  $L_c = 6.18 \text{ mm}$  and  $A_p = 1.57 \times 10^{-6} \text{ m}^2$  from Ex. 11.6,  $L_c^{3/2} (h_h / kA_p)^{1/2} = 1.52$  and Fig. 3.20 gives  $\eta_f \approx 0.40$ . Hence,

$$\eta_{o,h} = 1 - \frac{A_f}{A} (1 - \eta_f) = 1 - 0.83(1 - 0.4) = 0.50.$$

Hence,

$$\frac{1}{U_h} = \frac{1}{(10^4 \text{ W/m}^2 \cdot \text{K})0.143} + 5.55 \times 10^{-4} \text{ m}^2 \cdot \text{K/W} + \frac{1}{0.50(230 \text{ W/m}^2 \cdot \text{K})}$$

$$U_h = 100.5 \text{ W/m}^2 \cdot \text{K}.$$

With

$$C_{\min} = C_h = 3 \text{ kg/s}(1081 \text{ J/kg} \cdot \text{K}) = 3243 \text{ W/K}$$

$$NTU = \frac{U_h A_h}{C_{\min}} = \frac{100.5 \text{ W/m}^2 \cdot \text{K} (36.05 \text{ m}^2)}{3243 \text{ W/K}} = 1.117.$$

Since  $C_{\min}/C_{\max} = 0$ , Eq. 11.35a gives

$$\varepsilon = 1 - \exp(-NTU) = 1 - \exp(-1.117) = 0.673.$$

Hence,

$$q = \varepsilon C_{\min} (T_{h,i} - T_{c,i}) = 0.673(3243 \text{ W/K})(500 \text{ K}) = 1.091 \times 10^6 \text{ W}$$

and

$$T_{h,o} = T_{h,i} - \frac{q}{C_{\min}} = 900 \text{ K} - \frac{1.091 \times 10^6 \text{ W}}{3243 \text{ W/K}} = 564 \text{ K}.$$

<

**COMMENTS:** (1) The assumption of  $\bar{T}_h = 725 \text{ K}$  is good.

(2) If water enters the tubes as saturated liquid, a flow rate of at least

$$\dot{m}_c = \frac{q}{h_{fg}} = \frac{1.091 \times 10^6 \text{ W}}{2.183 \times 10^6 \text{ J/kg}} = 0.50 \text{ kg/s}$$

would be need to maintain saturated conditions in the tubes.